

美特鋁質有限公司

MIDI ALUMINIUM FABRICATOR LTD.



工程指示 / 要求簡箋 ENGINEER INSTRUCTIONS(E.I.)

工程指示編號:	EI- 6461 / 23	修改版本:	-
	HK-		
工程編號:	J 859	工程名稱:	啟德6551
收件人:	maggie	發件人:	nero
工程項目:	後裝窗 - 地盤用配件(不鏽鋼磨耳)	日期:	10/07/2023

<input type="checkbox"/> 原合約工程包	<input type="checkbox"/> 原合約工程加 / 減賬 QT-	<input type="checkbox"/> 新工程報價 QT-
---------------------------------	--	------------------------------------

信件批核號碼/圖紙參考編號:	批核模具圖紙編號:
客戶指示附件:	管理內部批簽署:

<input type="checkbox"/> 初步鋁料 B.M.	<input type="checkbox"/> 加工拆圖, 然後生產	<input type="checkbox"/> 尺寸表
<input type="checkbox"/> 正式鋁料 B.M.	<input type="checkbox"/> 技術上資料/指示	<input type="checkbox"/> 報價
<input type="checkbox"/> 配件 B.M.	<input type="checkbox"/> 樣辦或貨品說明書	<input type="checkbox"/> 分判合約
<input type="checkbox"/> 其他:		

內容:
請按附件資料訂購,
grade 304 1.5mm 不鏽鋼磨耳, 送地盤。

*其中J859-M70-1、J859-M70-2、J859-M70-5、J859-TM-1、J859-TM-2
共5款編號磨耳先訂購一半數量, 到現場安裝時調整尺寸後才訂餘下數量。

**不鏽鋼厚度不得少於 < 1.5mm

完成上列要求日期: 16/08/2023

國內

<input type="checkbox"/> 生產技術總監	<input type="checkbox"/> 連附件	<input type="checkbox"/> 技術部	<input type="checkbox"/> 連附件	<input type="checkbox"/> 生產部	<input type="checkbox"/> 連附件
<input type="checkbox"/> 採購部	<input type="checkbox"/> 連附件	<input type="checkbox"/> 生產統籌部	<input type="checkbox"/> 連附件	<input type="checkbox"/> 報關組	<input type="checkbox"/> 連附件
<input type="checkbox"/> 質檢部	<input type="checkbox"/> 連附件	<input type="checkbox"/> 會計部	<input type="checkbox"/> 連附件	<input type="checkbox"/> 機械設計部	<input type="checkbox"/> 連附件
<input type="checkbox"/> 香港辦	<input type="checkbox"/> 連附件	<input type="checkbox"/> 其他:			

香港

<input type="checkbox"/> 行政部	<input type="checkbox"/> 連附件	<input type="checkbox"/> 會計部	<input type="checkbox"/> 連附件	<input type="checkbox"/> 統籌部	<input type="checkbox"/> 連附件	<input type="checkbox"/> 工程部	<input type="checkbox"/> 連附件
<input checked="" type="checkbox"/> 採購部	<input checked="" type="checkbox"/> 連附件	<input type="checkbox"/> QS部	<input type="checkbox"/> 連附件	<input checked="" type="checkbox"/> 地盤管理	<input checked="" type="checkbox"/> 連附件	<input type="checkbox"/> 維修部	<input type="checkbox"/> 連附件

*發件人簽署:		*組別成員批核簽署:	
傳遞編號:		項目經理簽署:	

Maximum offset between glass framing members at corners of glazing pockets shall not exceed 0.8mm.

4.4 Glazing

1. Glazing shall be accomplished from the inside of building wherever possible. The glazing system shall be designed to this end using continuous neoprene compression gaskets on both sides. A continuous "wet" seal shall be employed to insure complete water tight. Maintain a minimum glazing bite, edge clearance and surface clearance depending on the glass used as recommended by the glass manufacturer.
2. Glazing by Structural Silicone Sealant
 - a) The glass to be glazed with structural silicone sealant applied in strict accordance with the manufacturer's published instructions and shall be applied only by workman specifically trained or experienced in their use.
 - b) All QC records shall be kept in the factory.
 - c) On-site structural sealant glazing shall strictly follow manufacturer's published instruction and on-site deglazing test is required to ensure the quality of work.
3. Gasket and Sealant Application
 - a) Sealant and gasket shall be provided where shown on the drawing or required for a permanently weather tight installation. The sealing mechanism for each location and use shall be as indicated on drawing. In those locations where a mechanism is necessary but is not indicated, it shall be of type recommended by the Sub-contractor and approved by the Architect.
 - b) Protect all adjoining surface not to receive sealant against staining by masking and/or other method.
 - c) Joint and joint surface shall be clean, dry, and free of any material that may have an adverse effect on the bonding and/or seal of the sealant and gasket material.
 - d) Apply sealant and gasket under the condition recommended by the manufacturer(s). Prime all surface to receive sealant and gasket unless recommended otherwise, use no sealant that has started to set in its container or a sealant that has exceeded the self life published by the manufacturer.
 - e) Fill all joint continuously and completely with sealant, forming neat, uniform, concave beads. Finish the material flush with adjoining surface unless otherwise shown on the drawing. All sealant surface shall be tooled smooth.

4.5 ANCHORAGE SYSTEM AND SUPPORT BRACKET

4.5.1 General

1. Provide all required anchor and fixing to assemble and install work in a neat, secure manner, including bolt, washer, screw, rivet, weld, proprietary fastener, and the like, template and other accessories of approved type for a completion installation.
2. For façade elements (such as windows, louvres and doors etc.), the fixing lug shall be stainless steel of minimum grade 304 (1.4301 to BS EN 10088) and fixed to outer frame of façade

elements at maximum spacing at 300mm centre. Shot fixing lugs are to project at least 50 mm from the edge of outer frame and shall be at least 1.5 mm thick x 30 mm x 120 mm.

3. Fixing shall be of the type and size appropriate for the purpose and location in accordance with manufacturer's instruction, be sufficient to transmit the imposed loads and stress and ensure the rigidity of the assembly. All fixing shall be new and undamaged.
4. Fixing shall be corrosion resistant, and non-staining to adjacent work. Fixing shall be concealed unless otherwise approved or indicated on the Drawing. Submit detail, including structural calculation and shop drawing where required, including type, size and spacing of all items.
5. Any fastener to be cast into concrete shall be supplied and installed by the Sub-contractor. The Sub-contractor shall be responsible for coordinating with the Main Contractor and check the building frame and the exact position of fixing bolt or angle on site and to install anchor to suit the Main Contractor's programme.
6. The Sub-contractor shall also make necessary modification to the anchor, ties to suit different site condition of steel reinforcement without additional charge.
7. Aluminium alloy, stainless steel or nylon for all exposed fixing including screw, nut, bolt, washer and rivet and match up with finish where possible. Use stainless steel or steel with an anti-corrosion treatment for all concealed fastening device.

4.5.2 Post-drill anchor

1. Mechanical masonry anchor of size M8, M10, M12 & M16 are to be Hilti (HST3-R) or Fischer (FAZ II A4) for cracked and uncracked concrete. Anchor bolt of size M20 is not recommended to use in project. All anchor bolts shall be listed on pre-approval material list of Central Data Bank by Buildings Department. All anchors are to be installed in accordance with the manufacturer's requirement. The Sub-contractor shall be responsible for confirming that all edge distance, spacing and embedment requirement is satisfied.
2. The Sub-contractor shall be responsible for ensuring that where masonry anchor clash. With reinforcement, there is an alternative anchor set-out that satisfies the design requirement. End plate modification to suit a new anchor set-out are to be carried out in accordance with BS 5950, slotting of hole and flame cutting are not permitted. Holes in the concrete are to be repaired by dry packing with a 40 MPa cementitious non-shrink grout.

4.5.3 Cast-in embed / Cast-in channel / Bracket

1. All fixing brackets shall be Aluminium grade 6061-T6 for internal and external use; Hot-dip galvanized mild steel according to BS EN ISO 1461 or Grade 1.4301 (formerly Grade 304) stainless steel for internal use; or Grade 1.4401 (formerly Grade 316) stainless steel for external use. Finish exposed fasteners to match adjacent aluminium.
2. Inserts in the building structure such as cast-in embed or cast-in channel located in the dry area shall be either Grade 1.4301 (formerly Grade 304) stainless steel as minimum or Hot-dip galvanized steel according to BS EN ISO 1461 with a minimum grade of S235. Cast-in channel shall be manufactured from Grade 316 stainless steel when they are used for the building structure located in the wet area.
3. Cast-in channel (or anchor channel) are to be Halfen, Hilti or Jordahl. All proprietary channel products shall be listed on pre-approval material list of Central Data Bank by Buildings

	美特鋁質有限公司	工程號:	J-859	計算:	林仁安	日期:	2023.04.06	送呈:	施哥	
	MIDI Aluminium Fabricator Ltd.	地盤名稱:	啟德站	核對:	AN	日期:	2023.04.09	副本:		
地盤用配件B.M.表		項目類別:	后裝窗(不鏽鋼磨耳)	批准:		日期:				
BM編號: 859-WI-M01-F-XXX		A/C Code:						此BM依據EI4548A版施工圖紙計算		
序號	修改標示	配件圖號	物料編號	配件名稱	顏色	實用	後備	總數	單位	備注
1			J859-M50-1	50窗磨耳	1.5mm 304不鏽鋼	186	50	236	支	用于50窗 (@300C/C)
2			J859-M50-2	50窗磨耳	1.5mm 304不鏽鋼	326	50	376	支	用于50窗 (@300C/C)
3		先訂購一半 (數量: 1019)	J859-M70-1	70窗磨耳	1.5mm 304不鏽鋼	1987	50	2037	支	用于70窗/FD門框 (@300C/C)
4		先訂購一半 (數量: 662)	J859-M70-2	70窗磨耳	1.5mm 304不鏽鋼	1273	50	1323	支	用于70窗/FD門框 (@300C/C)
5			J859-M70-3	70窗磨耳	1.5mm 304不鏽鋼	180	30	210	支	用于70窗/FD門框 (@300C/C)
6			J859-M70-4	70窗磨耳	1.5mm 304不鏽鋼	668	30	698	支	用于70窗/FD門框 (@300C/C)
7		先訂購一半 (數量: 1060)	J859-M70-5	70窗磨耳	1.5mm 304不鏽鋼	2070	50	2120	支	用于70窗/FD門框 (@300C/C)
8			J859-M70-6	70窗磨耳	1.5mm 304不鏽鋼	284	30	314	支	用于70窗/FD門框 (@300C/C)
9		先訂購一半 (數量: 873)	J859-TM-1	趟門磨耳	1.5mm 304不鏽鋼	1645	100	1745	支	用于趟門框 (@300C/C)
10		先訂購一半 (數量: 873)	J859-TM-2	趟門磨耳	1.5mm 304不鏽鋼	1645	100	1745	支	用于趟門框 (@300C/C)

 美特鋁質有限公司 MIDI Aluminium Fabricator Ltd.				類別		物料號	-	
				制圖	林仁安	2023-05-10	圖號	J859-M50-1
修改				復核	-	-	供應商	-
日期				批准			描圖	

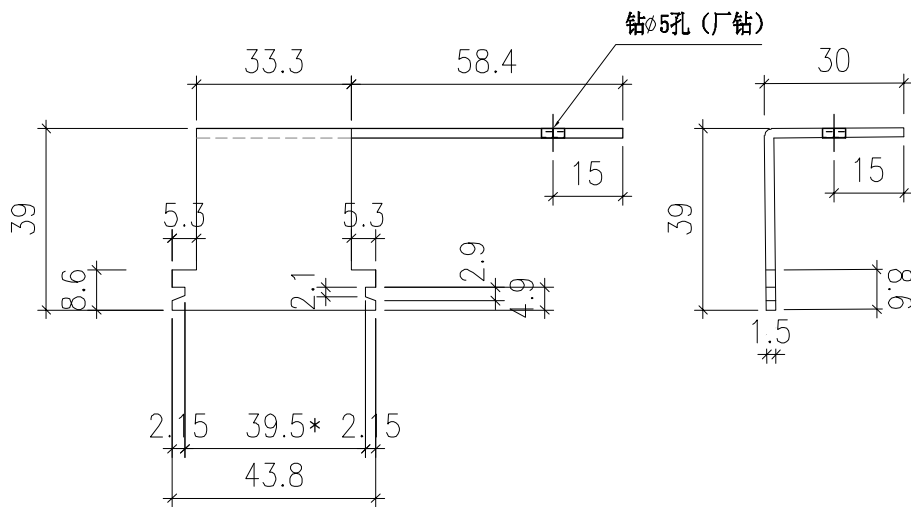

厂要按图折好

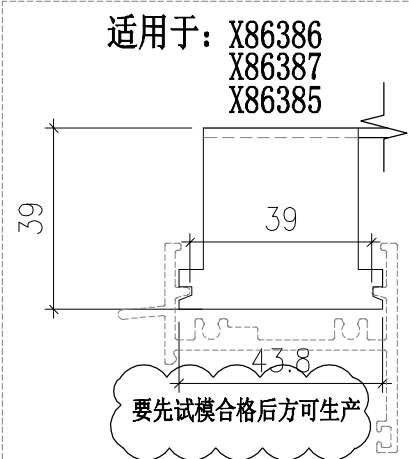

注：帶“*”號為重要尺寸

工程號	J-859	地盤	启德站	採 用	附 件		
名稱	50窗頂底不銹鋼磨耳						
材料	1.5mm(304)		地盤			✓	
顏色	-		工廠				

 美特鋁質有限公司 MIDI Aluminium Fabricator Ltd.				類別		物料號	-	
修改				制圖	林仁安	2023-05-10	圖號	J859-M50-2
日期				復核	-	-	供應商	-
				批准			描圖	

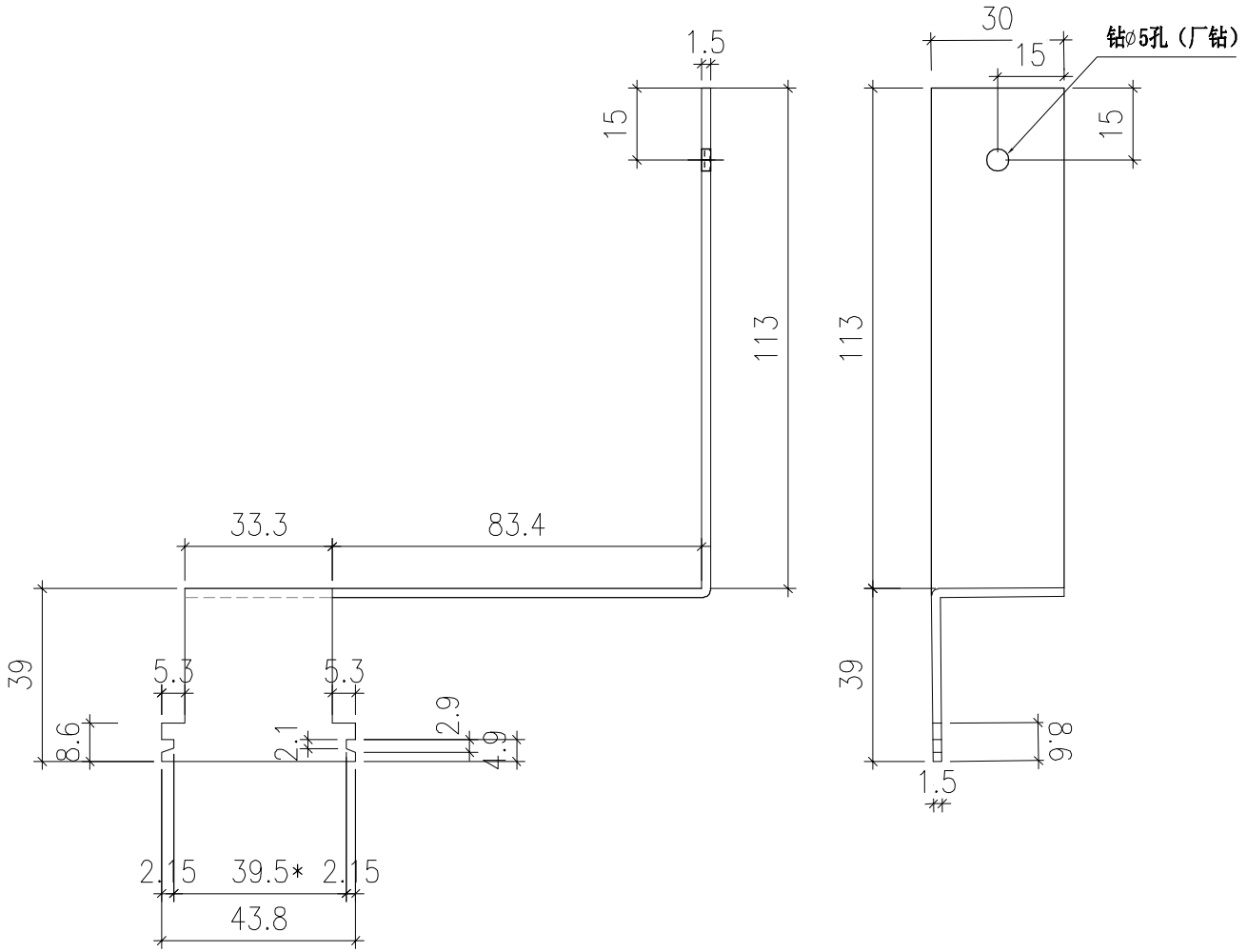

厂要按图折好

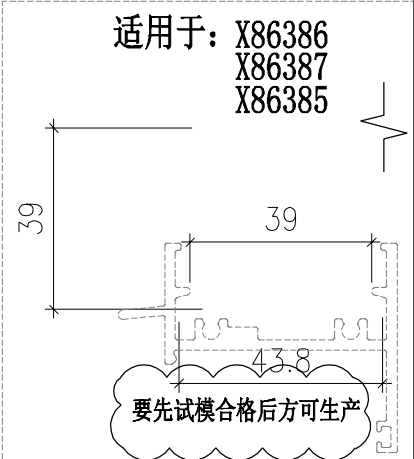

注：帶“*”號為重要尺寸

工程號	J-859	地盤	启德站	附件	
名稱	50窗頂底不銹鋼磨耳		採用		
材料	1.5mm(304)		地盤		✓
顏色	-		工廠		

 美特鋁質有限公司 MIDI Aluminium Fabricator Ltd.				類別		物料號	-	
修改				制圖	林仁安	2023-05-10	圖號	J859-TM-1
日期				復核	-	-	供應商	-
				批准			描圖	

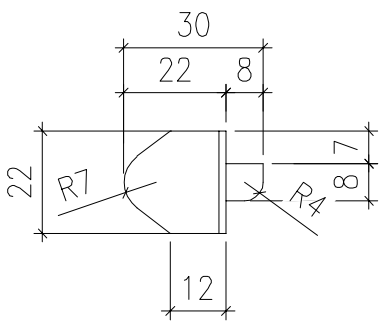
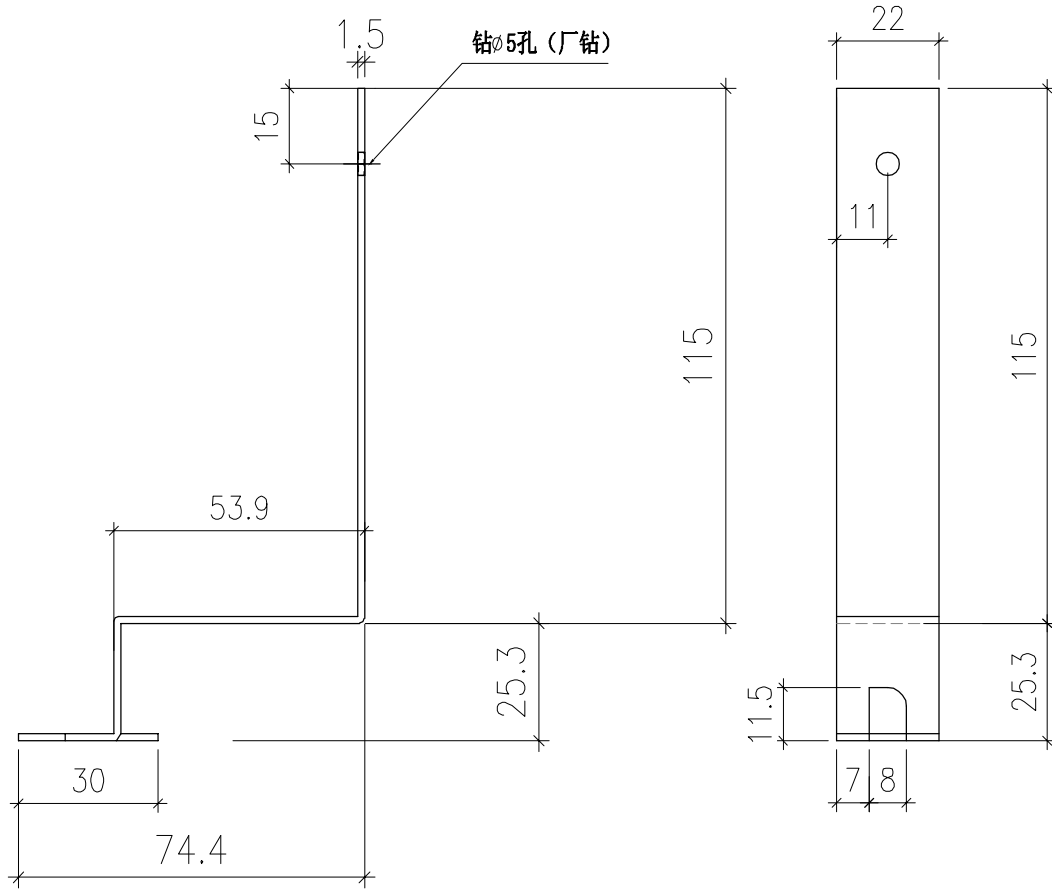

厂要按图折好

注：帶“*”號為重要尺寸

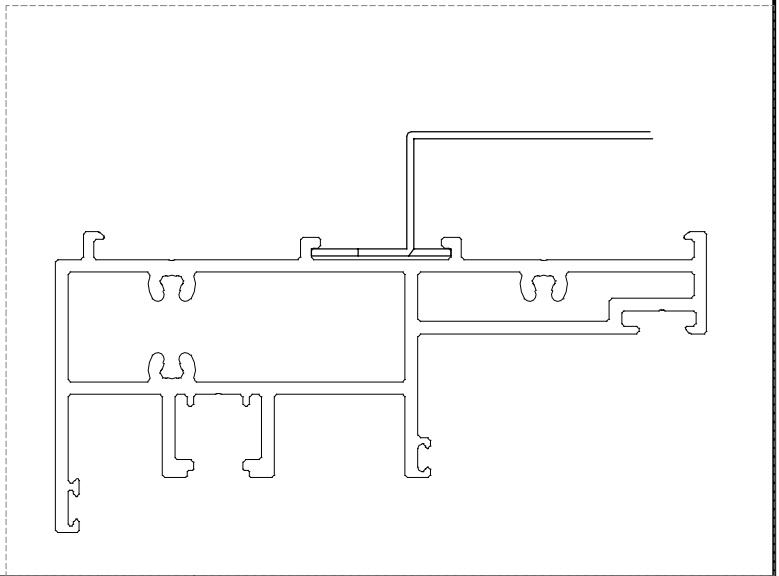

工程號	J-859	地盤	啟德站			附件	
名稱	50窗頂底不銹鋼磨耳		採用				
材料	1.5mm(304)		地盤	✓			
顏色	-		工廠				

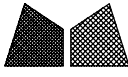
 美特鋁質有限公司 MIDI Aluminium Fabricator Ltd.				類別		物料號	-	
				制圖	林仁安	2023-05-10	圖號	J859-TM-2
修改				復核	-	-	供應商	-
日期				批准			描圖	

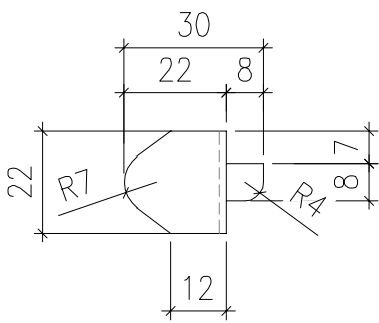
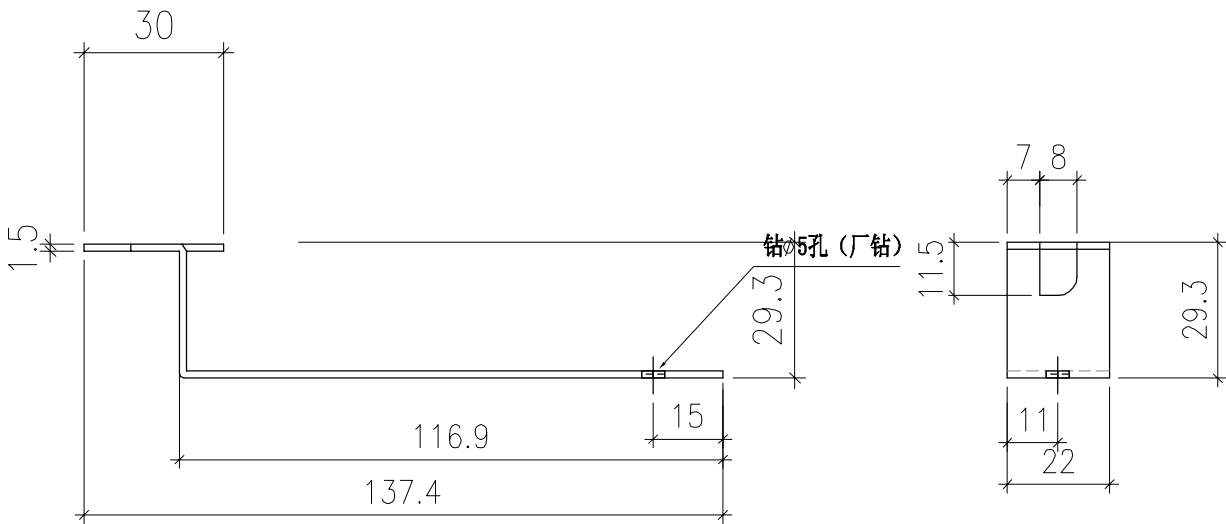

厂要按图折好

注：帶“*”號為重要尺寸

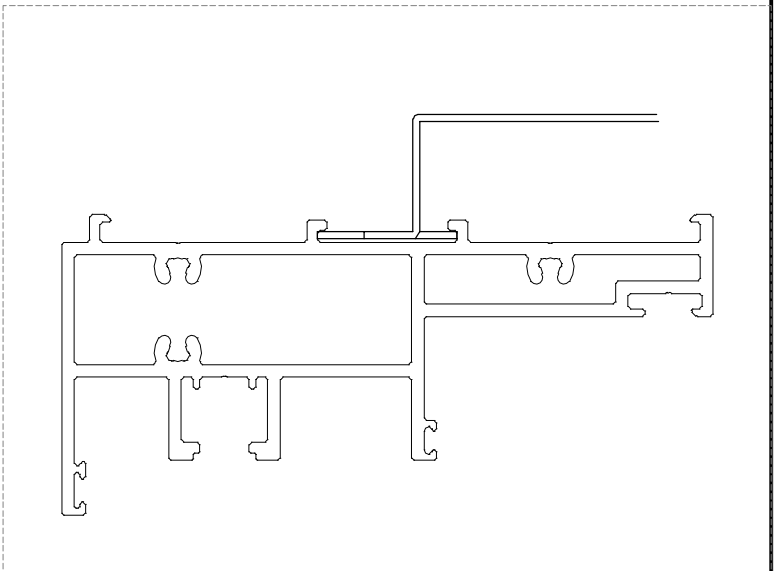

工程號	J-859	地盤	启德站			附件	
名稱	50窗頂底不銹鋼磨耳		採用				
材料	1.5mm(304)		地盤	✓			
顏色	-		工廠				

 美特鋁質有限公司 MIDI Aluminium Fabricator Ltd.				類別		物料號	-	
修改				制圖	林仁安	2023-05-10	圖號	J859-M70-1
日期				復核	-	-	供應商	-
				批准			描圖	

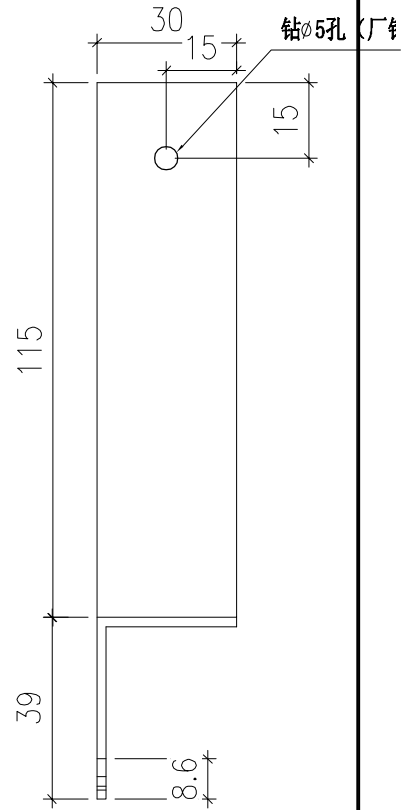
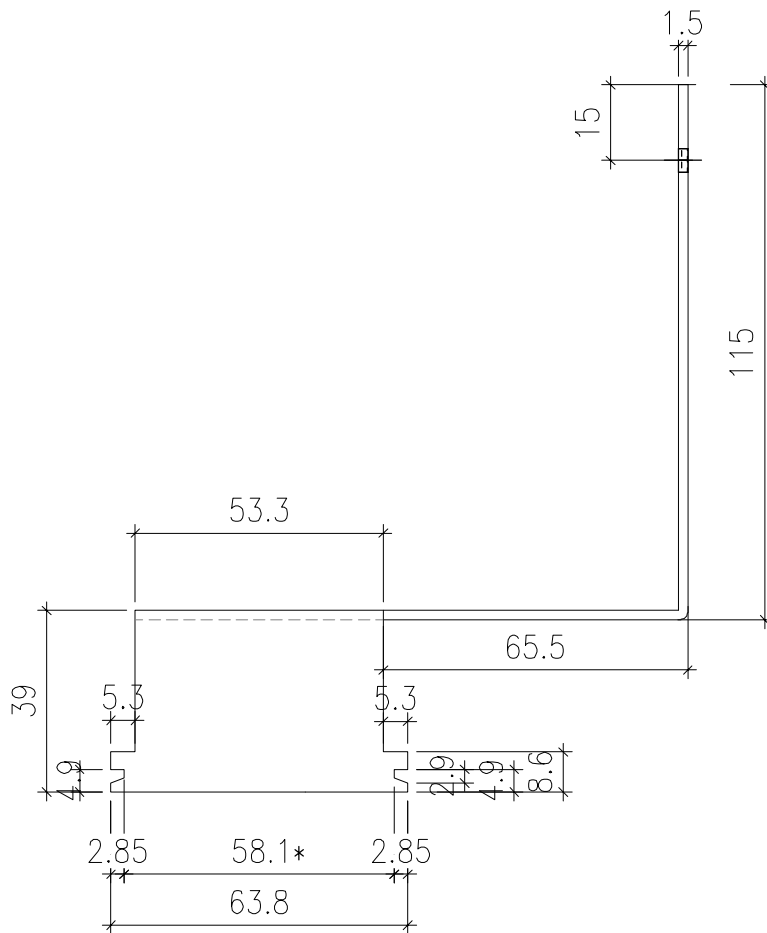

厂要按图折好

适用于: X86381
X86389
X86388

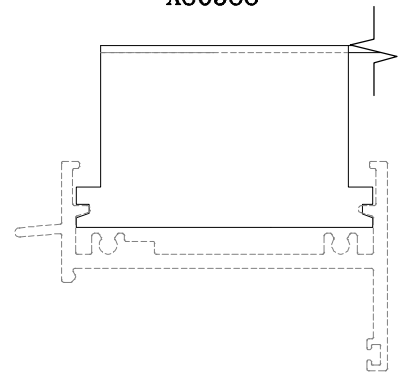

注：帶“*”號為重要尺寸

工程號	J-859	地盤	启德站	附件	
名稱	70預制窗磨耳加工圖		採用		
材料	1.5mm(304)		地盤		✓
顏色	-		工廠		

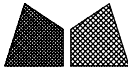
 美特鋁質有限公司 MIDI Aluminium Fabricator Ltd.				類別		物料號	-	
修改				制圖	林仁安	2023-05-10	圖號	J859-M70-2
日期				復核	-	-	供應商	-
				批准			描圖	

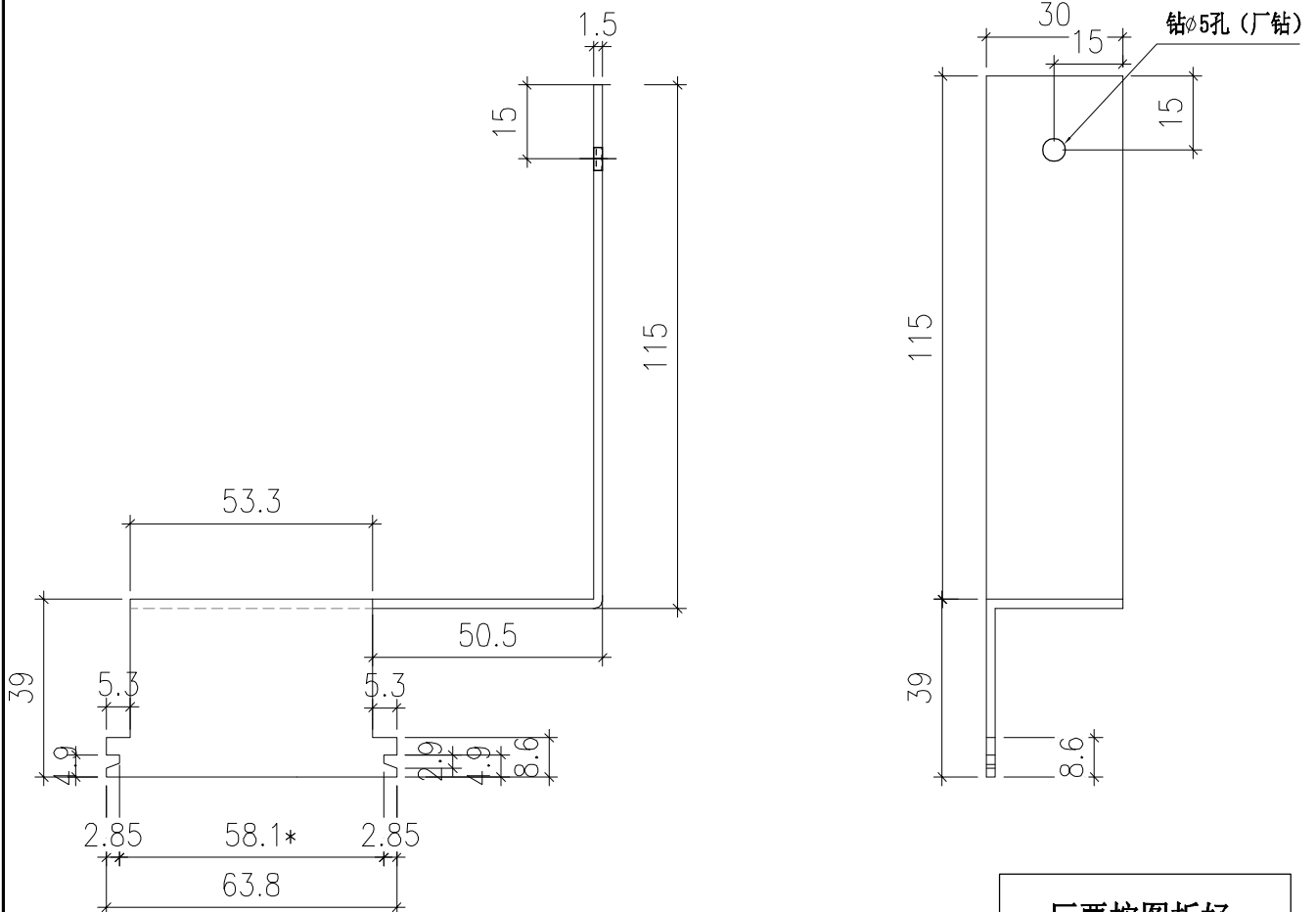

厂要按图折好

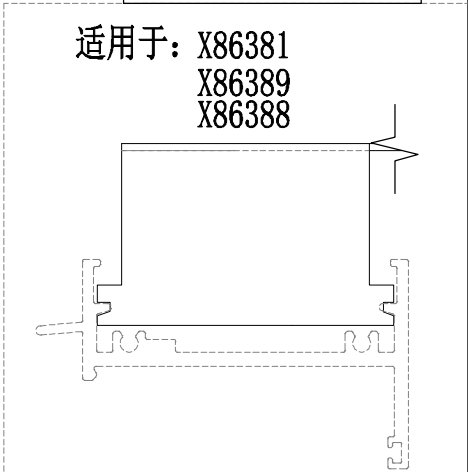

注：帶“*”號為重要尺寸

工程號	J-859	地盤	启德站	附件	
名稱	70預制窗磨耳加工圖		採用		
材料	1.5mm(304)		地盤		✓
顏色	-		工廠		

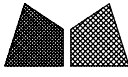
 美特鋁質有限公司 MIDI Aluminium Fabricator Ltd.				類別		物料號	—	
				制圖	林仁安	2023-05-10	圖號	J859-M70-3
修改				復核	—	—	供應商	—
日期				批准			描圖	

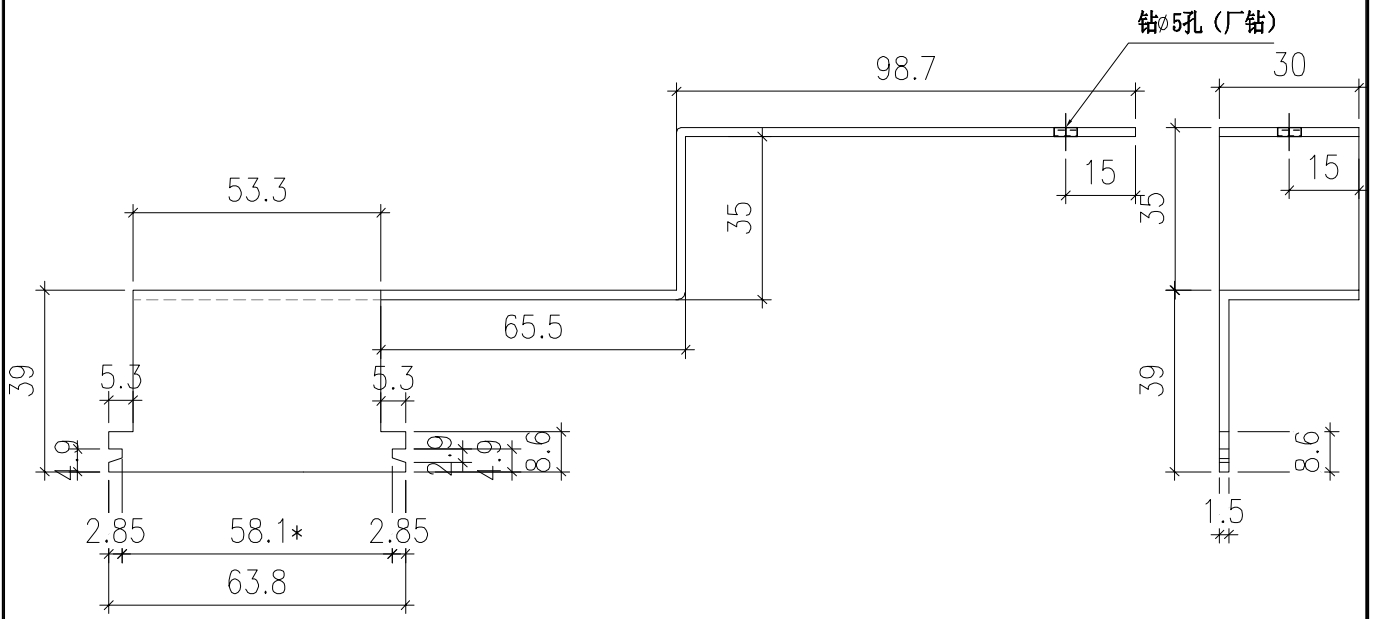

厂要按图折好

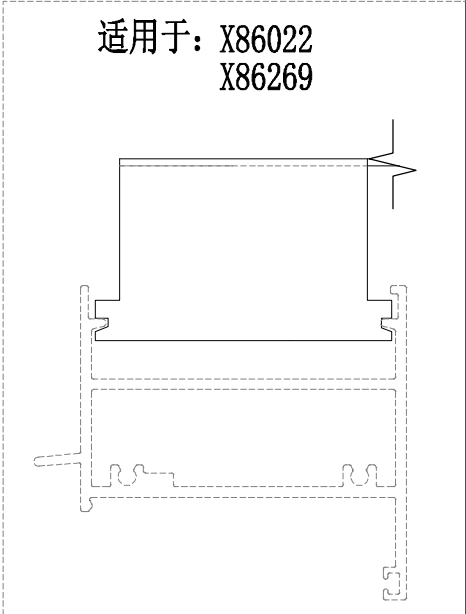

注：帶“*”號為重要尺寸

工程號	J-859	地盤	啟德站	採 用	附 件	
名稱	70預制窗磨耳加工圖					
材料	1.5mm(304)		地盤			✓
顏色	—		工廠			

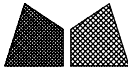
 美特鋁質有限公司 MIDI Aluminium Fabricator Ltd.				類別		物料號	—	
				制圖	林仁安	2023-05-10	圖號	J859-M70-4
修改				復核	—	—	供應商	—
日期				批准			描圖	

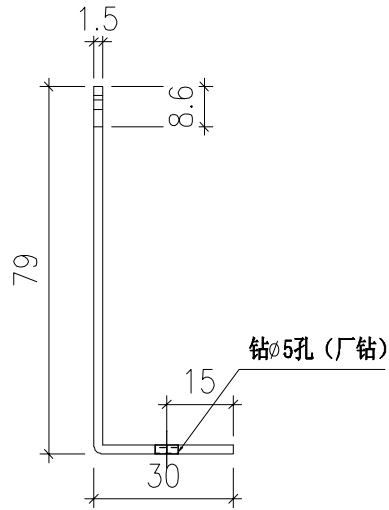
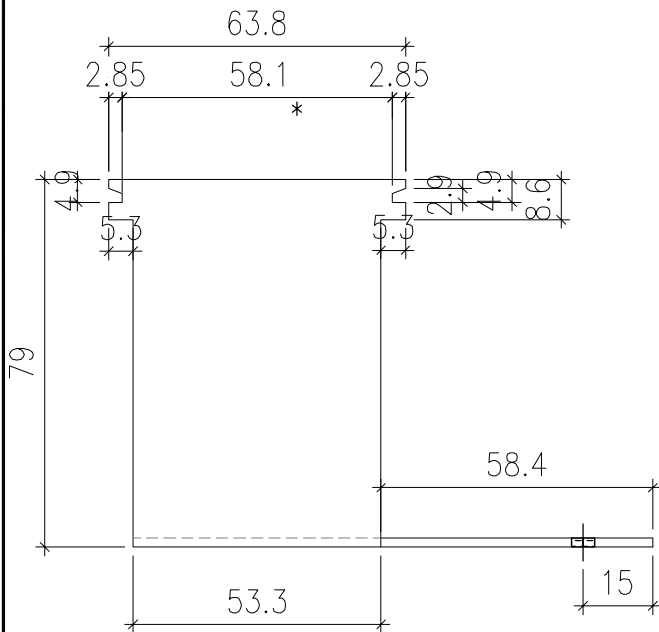

厂要按图折好

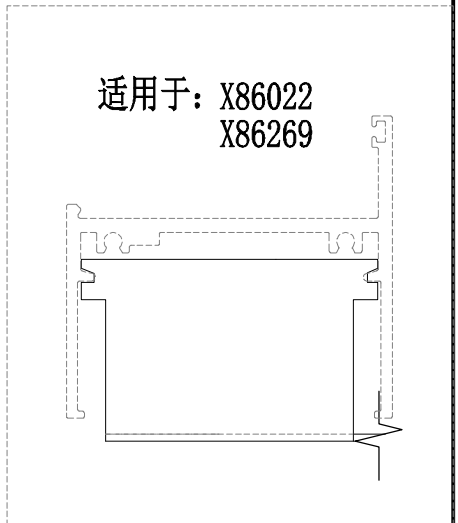

注：帶“*”號為重要尺寸

工程號	J-859	地盤	启德站	附件	
名稱	70預制窗磨耳加工圖		採用		
材料	1.5mm(304)		地盤		✓
顏色	—		工廠		

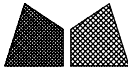
 美特鋁質有限公司 MIDI Aluminium Fabricator Ltd.				類別		物料號	-	
				制圖	林仁安	2023-05-10	圖號	J859-M70-5
修改				復核	-	-	供應商	-
日期				批准			描圖	

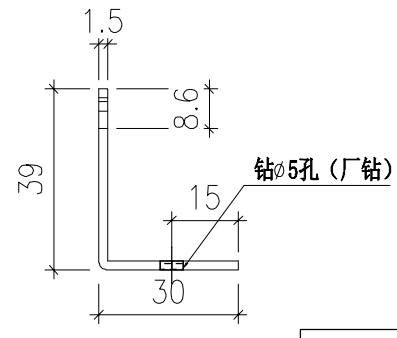
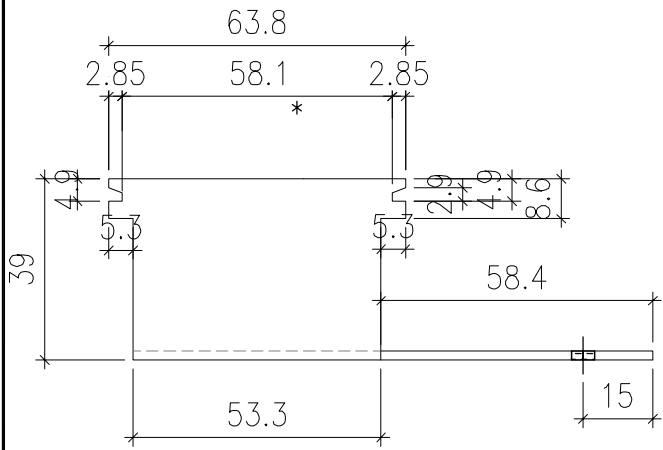

厂要按图折好

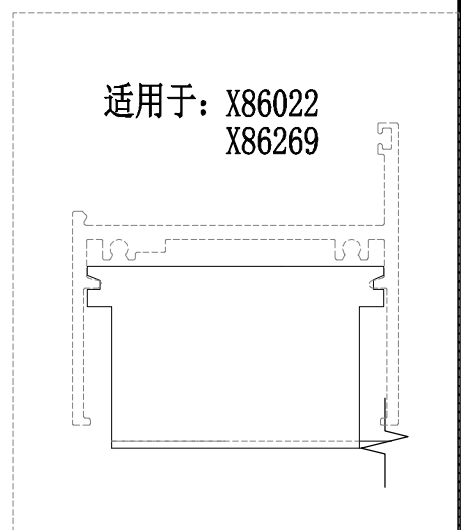

注：帶“*”號為重要尺寸

工程號	J-859	地盤	启德站	附 件	
名稱	70預制窗磨耳加工圖		採用		
材料	1.5mm(304)		地盤		✓
顏色	-		工廠		

 美特鋁質有限公司 MIDI Aluminium Fabricator Ltd.				類別		物料號	-	
				制圖	林仁安	2023-05-10	圖號	J859-M70-6
修改				復核	-	-	供應商	-
日期				批准			描圖	

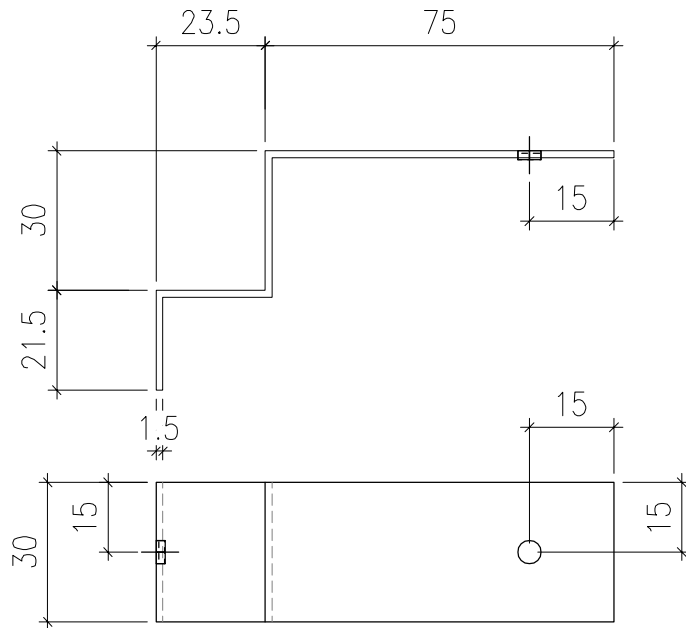

厂要按图折好

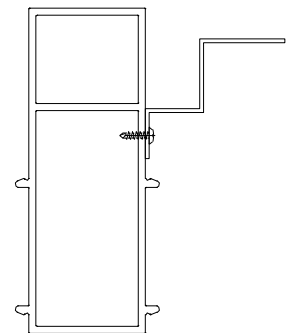

注：帶“*”號為重要尺寸

工程號	J-859	地盤	启德站			附件	
名稱	70預制窗磨耳加工圖		採用				
材料	1.5mm(304)		地盤	✓			
顏色	-		工廠				