



工程指示 / 要求簡箋(E.I.)

工程指示編號：EI / 7928 / 24

修改版次：-

工程編號：J - 858

工程名稱：將軍澳日出康城 11

工程項目：(特色層) 後裝窗 (T3 B-A/U-1) 鋁料加工圖 (1 隻) 67/F

收件人：生統

發件人：Ant Yeung

日期：13/06/2024

原本大圖取消，現在業主要求補回生產。

請依圖紙安排生產 1 隻窗 (T3 B-A/U-1)，送地盤 T3 安裝

X86251 已欠料，請使用 X86157 / X86158 或 X86162 代替 X86251

水線孔按 EI4666G 指示

急

按 EI 7910 拆圖

附工序明細表，開料單及加工單

請在 2024.06.20 前完成上列要求。

附： 頁

分發東莞各部門：

- () 生產技術總監 連附件 () 技術部 連附件 () 生產部 連附件 () 機械設計部 連附件
 () 採購部 連附件 (✓) 生產統籌部 連附件 (✓) 小羅&清 連附件
 () 質檢部 連附件 () 會計部 連附件 () 報關組 連附件 () 其他 _____ 連附件

分發香港各部門：

- () 行政部 連附件 () 會計部 連附件 () 統籌部 連附件 (✓) 工程部地盤科文 連附件 積哥，二寶
 () 採購部 連附件 () QS 部 連附件 () 維修部 連附件 () 其他 _____ 連附件

傳遞編號：

HK 1146 / 24

發件人簽署：

項目經理簽署：

記錄用

midi@midiltd.com.hk

From: j858@midiltd.com.hk <j858@midiltd.com.hk>
To: Billy.Kan@gammonconstruction.com, Rick.Chung@gammonconstruction.com,
j3931@gammonconstruction.com, KaHei.Wong@gammonconstruction.com,
Woody.Wong@gammonconstruction.com, Ben.Chan@gammonconstruction.com,
Leo.Pong@gammonconstruction.com, Donny.Lo@gammonconstruction.com,
Peter.Manc@gammonconstruction.com, Edward.Chiang@gammonconstruction.com,
Eunice.Tang@gammonconstruction.com, rss19084mw@rlphk.com,
P19084@rlp.asia, marinatong@rlp.asia,
ginnychau@rlp.asia, wallaceng@rlp.asia,
andywchan@sino.com, terrywan@sino.com,
simonspleung@sino.com, kennethleung@sino.com,
stephenchow@sino.com
Subject: LP11- Cw- 需要補回生產 取消的1隻窗 T3B-A/ U-1
Copies to: ant.ysy.midi@gmail.com <ant.ysy.midi@gmail.com>, jason.lcs.midi@gmail.com <jason.lcs.midi@gmail.com>
paul.wpc.midi@gmail.com <paul.wpc.midi@gmail.com>
Date sent: Wed, 05 Jun 2024 16:05:00 +0800

Dear All

按早前會議要求，早前取消的1隻窗 T3B-A/ U-1 需要補回生產。

跟12 th GBP 的位置。安裝此窗。

請留意。

謝謝

源

Attachments: T:\Jobs\J-858\7 Email & Letter\Email\to Gammon\20240605 補回 取消的1隻窗
T3B-A U-1 售樓書 GBP Shop dwg\20240605 補回 取消的1隻窗 T3B-A U-1 售樓書 GBP
Shop dwg.pdf

BD. REF :
 The information is preliminary and subject to change.
 The information is intended for use as a guide only.
 The information is intended for use as a guide only.
 Prepared by: **Maria Wong** 11 Aug 2022
 Checked by: **Maria Wong** 11 Aug 2022
 No other kinds of digital electronic signatures.
 The information is intended for use as a guide only.
 The information is intended for use as a guide only.
 The information is intended for use as a guide only.

CLIENT : **信和置業有限公司**
Sino Land Company Limited

ARCHITECT : **ronald lu & partners**
Ronald Lu & Partners (HK) Ltd.
 呂志祥建築師事務所 (香港) 有限公司

MAIN CONTRACTOR : **Gammon**

STRUCTURAL ENGINEER : **AECOM**

FAÇADE CONSULTANT : **AECOM**

NOTE:
 1. ALL DIMENSIONS ARE IN MM.
 2. ALL ELEVATIONS ARE VIEWED FROM OUTSIDE.
 3. ALL DIMENSIONS TO BE VERIFIED ON SITE BEFORE FABRICATION.

LEGEND:
 ① - DETAIL MARK NO.
 ② - REFER SHEET NO.
 1. F.F.L. - FINISHED FLOOR LEVEL
 2. S.F.L. - STRUCTURAL FLOOR LEVEL
 3. (R) - REVERSED DETAIL

JOB NO. : J-858
 PROJECT : PROPOSED RESIDENTIAL DEVELOPMENT AT TKOTIL 70RP, PHASE 11, LOHAS PARK TSEUNG KWAN O, N.T.
 TITLE : IN-SITU ALUM. WINDOW ALUM. WINDOW SCHEDULE AT SPECIAL UNITS FLOOR
 DATE : 04-OCT-21 SCALE : 1:40
 DRAWN BY :
 CHECKED BY :
 美特鋁質有限公司
 MTDI Aluminium
 Units 6-8, Sunny Industrial Centre, 1/F
 610 Che Kwo Ling Road, Kowloon
 Tel: (852) 2777665
 Fax: (852) 2777665
 DWG NO. : J858-IW-2102c REV. : -

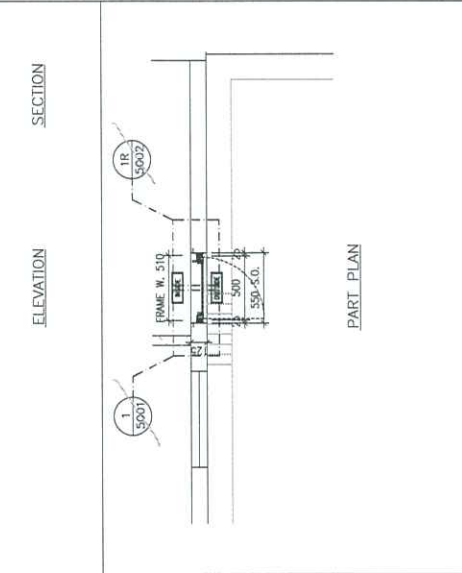
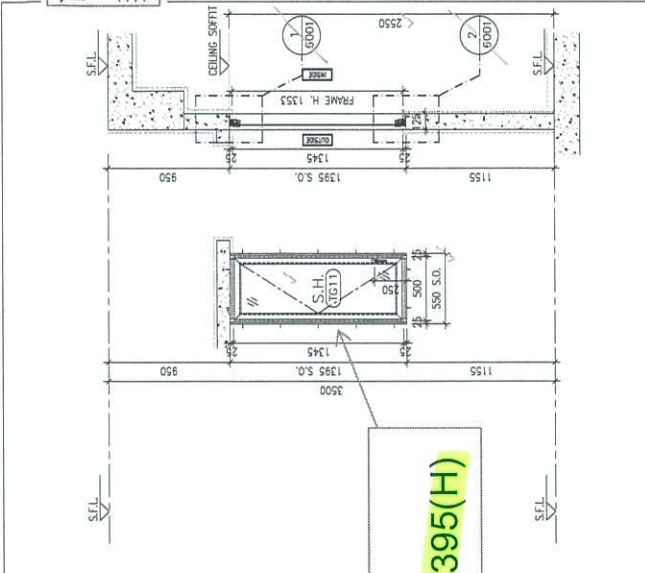

GLAZING AREA:	Required =	Provided = 0.7166
OPENABLE AREA:	Required =	Provided = 0.8134
WINDOW MARK:	(R-1)	(U-1)
LOCATION:	TOWER 3(3B) - FLAT A UTILITY (67/F)	
SECTION:	50mm ALUM. SECTION WITH PVF2 COATING (SLIVER CHAMPAGNE COLOUR)	
GLAZING:	6mm THK TEMPERED GLASS	
QUANTITY:	1 NO.	
REMARKS:	N/A	

拆此窗:
 S.O. : 550(W)x1395(H)

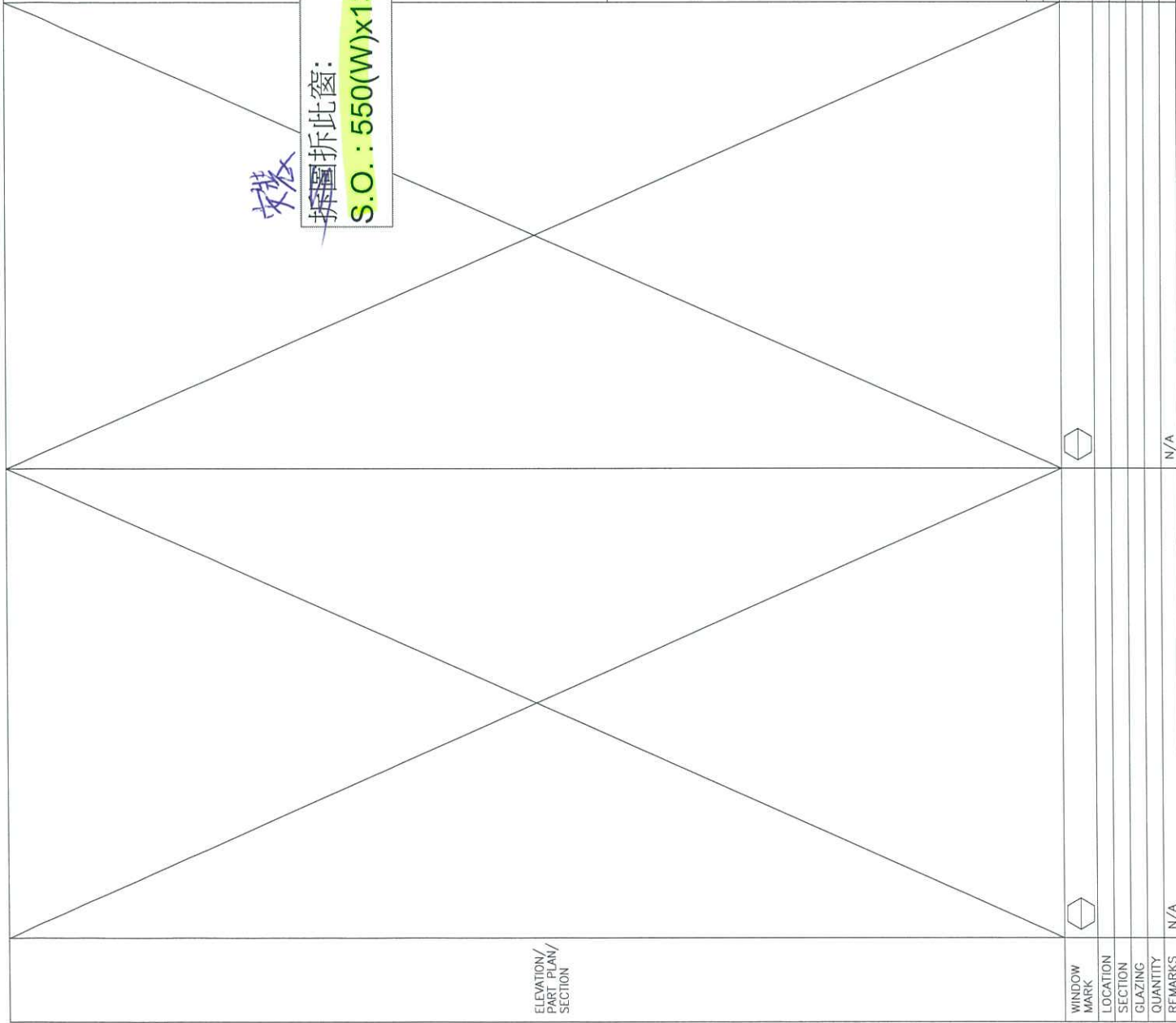

ELEVATION/
 PART PLAN/
 SECTION

工序明细表

工程名称		J-858(康城11期)					施工分区(批次) :		新增后装窗
采购原因		正常采购	工序号			材料发送地:		地盘	
序号	名称	组装件编号	图纸编号	长度L (mm)	宽度W (mm)	厚度T (mm)	数量	单位	备注
1	后装窗	A-AW-11SU	A-AW-11SU	520	1368	87.5	1	窗	送地盘
2									
3									
4									
5									
6									
7									
8									
9									
10									
11									
12									
13									
14									
15									
16									
17									
18									
19									
20									
21									
22									
23									
24									
25									
26									
27									
28									
29									
30									
31									
32									
33									
34									
35									
36									
37									
38									
39									
40									
41									
42									
43									
44									
45									
46									
47									

以下空白

说明: 1:注意保护成品, 严禁刻痕、划伤;

设计:

校对:

审核:

加工明细表

工程名称		J-858(康城11期)					施工分區(批次) :			新增后装窗铝料
采购原因		正常采购	工序号			材料发送地:		工厂		
序列号	型材模号	物料描述	图号	部件编号	长度 (mm)	数量	单位	颜色	备注	
1	L065	15x15x3铝角	J858-LM68	J858-LM68	140	10	件	铬化		
2	X86153	撞角码	J858-LM65	J858-LM65	45	2	件	铬化		
3	X86153	撞角码	J858-LM65	J858-LM65L	45	1	件	铬化		
4	X86153	撞角码	J858-LM65	J858-LM65R	45	1	件	铬化		
5	X86154	拉巴用压板1	J858-LM66	J858-LM66	80	3	件	ECD3X1009 9S-XF1		
6	X86155	拉巴用压板2	J858-LM67	J858-LM67	15	6	件	ECD3X1009 9S-XF1		
7	X86163	窗玉横	X86163-65	X86163-65A	1323	1	件	ECD3X1009 9S-XF1		
8	X86163	窗玉横	X86163-66	X86163-66A	1323	1	件	ECD3X1009 9S-XF1		
9	X86163	窗玉横	X86163-67	X86163-67LA	480	1	件	ECD3X1009 9S-XF1		
10	X86163	窗玉横	X86163-67	X86163-67LB	480	1	件	ECD3X1009 9S-XF1		
11	X86171	窗玉玻璃线企	X86171-65	X86171-65A	1258.5	1	件	ECD3X1009 9S-XF1		
12	X86171	窗玉玻璃线企	X86171-66	X86171-66A	1258.5	1	件	ECD3X1009 9S-XF1		
13	X86171	窗玉玻璃线横	X86171-66	X86171-66B	383.5	1	件	ECD3X1009 9S-XF1		
14	X86171	窗玉玻璃线横	X86171-67	X86171-67A	383.5	1	件	ECD3X1009 9S-XF1		
15	X86237	14x3拉巴	X86237-65	X86237-65A	123	1	件	ECD3X1009 9S-XF1		
16	X86237	14x3拉巴	X86237-65	X86237-65E	987	1	件	ECD3X1009 9S-XF1		
17	X86251	边企料	X86251-65	X86251-65	1368	1	件	ECD3X1009 9S-XF1		
18	X86251	边企料	X86251-66	X86251-66	1368	1	件	ECD3X1009 9S-XF1		
19	X86252	生顶横	X86252-65	X86252-65	482	1	件	ECD3X1009 9S-XF1		
20	X86253	生底横	X86253-65	X86253-65A	474	1	件	ECD3X1009 9S-XF1		
21										
22										
23										
24										
25										
26										
27										
28										
29										
30										
31										
32										
33										
34										
35										
36										
37										
38										
39										
40										
41										
42										
43										
44										
45										
46										
47										
48										
49										
50										
51										
52										
53										
54										
55										
56										
57										
58										
59										

以下空白

说明: 1:注意保护成品, 严禁刻痕、划伤;

设计: 校对: 审核:

FABRICATION DRAWING

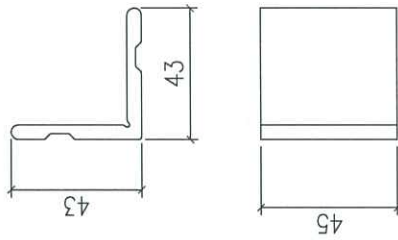

图号: J858-LM65
数量: 2只

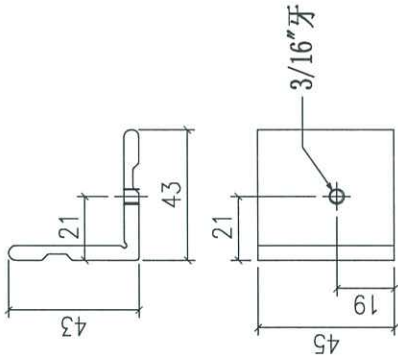

图号: J858-LM65L
数量: 1只

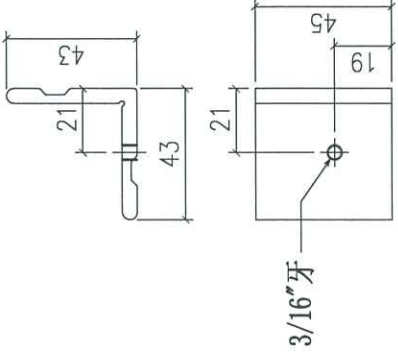

图号: J858-LM65R
数量: 1只

Remarks:		Checked: J.L.		Description: 窗玉组装角码		QTY: -		Delivery to Rev.		Date		Amendments	
Project Name: 康城11期		Date: 12-06-2024		Material: X86153		Tolerance: ±0.5		Factory					
Shop Drawing No. PRE-CAST ALUM. WINDOW & LOUVRE		Drawn: I.H.		Finish: MILL		Projection:		Site		Assembly No. J858-LM65		Rev. -	

FABRICATION DRAWING

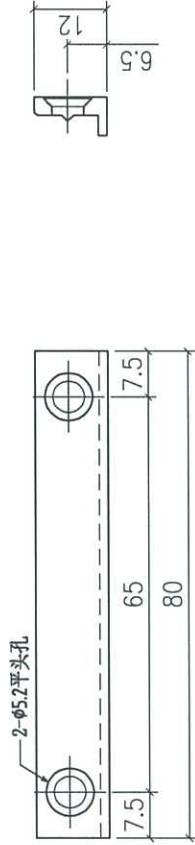

Remarks:		Checked: J.L.	Description: 拉巴用压板1	QTY: 51	Delivery to Rev.	Date	Amendments
Project Name: 康城11期	Project No. J858	Date: 12-06-2024	Material: X86154	Tolerance: ±0.5	Factory		
Shop Drawing No. PRE-CAST ALUM. WINDOW & LOUVRE	Rev. -	Drawn: I.H.	Finish: PWF2	Projection:	Site	Assembly No. J858-LM66	Rev. -
		Date: 12-06-2024					

FABRICATION DRAWING

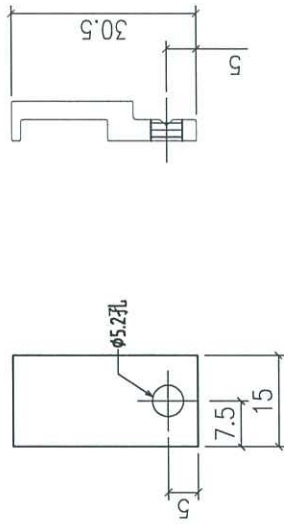

Remarks:		Checked: J.L.		Description: 拉巴用压板2		QTY: 102		Delivery to Rev.		Date		Amendments	
Project No. J858		Date: 12-06-2024		Material: X86155		Tolerance: ± 0.5		Factory					
Shop Drawing No. PRE-CAST ALUM. WINDOW & LOUVRE		Drawn: I.H.		Finish: PWF2		Projection:		Site		Assembly No.		Rev.	
		Date: 12-06-2024						J858-LM67					

FABRICATION DRAWING

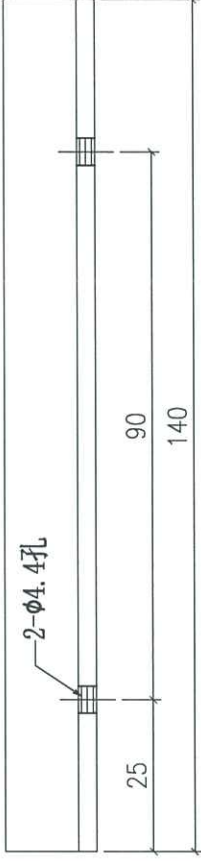
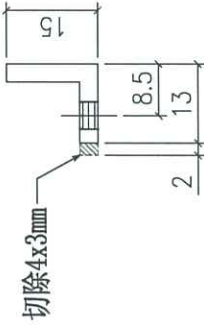
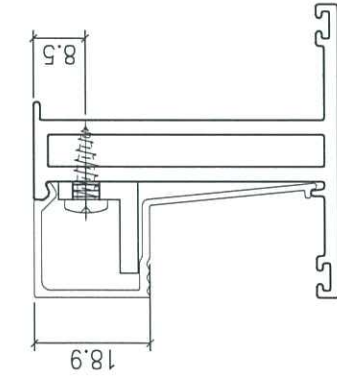

图号: J858-LM68
数量: 10只

Remarks:		Checked: J.L.		Description: 玻璃线加力铝角		QTY: -		Delivery to: Factory		Date		Amendments:	
Project Name: 康城11期		Date: 12-06-2024		Material: 15x15x3铝角		Tolerance: ±0.5		Site		Assembly No. J858-LM68		Rev. -	
Shop Drawing No. PRE-CAST ALUM. WINDOW & LOUVRE		Drawn: I.H.		Finish: MILL		Projection:							
		Date: 12-06-2024											

FABRICATION DRAWING

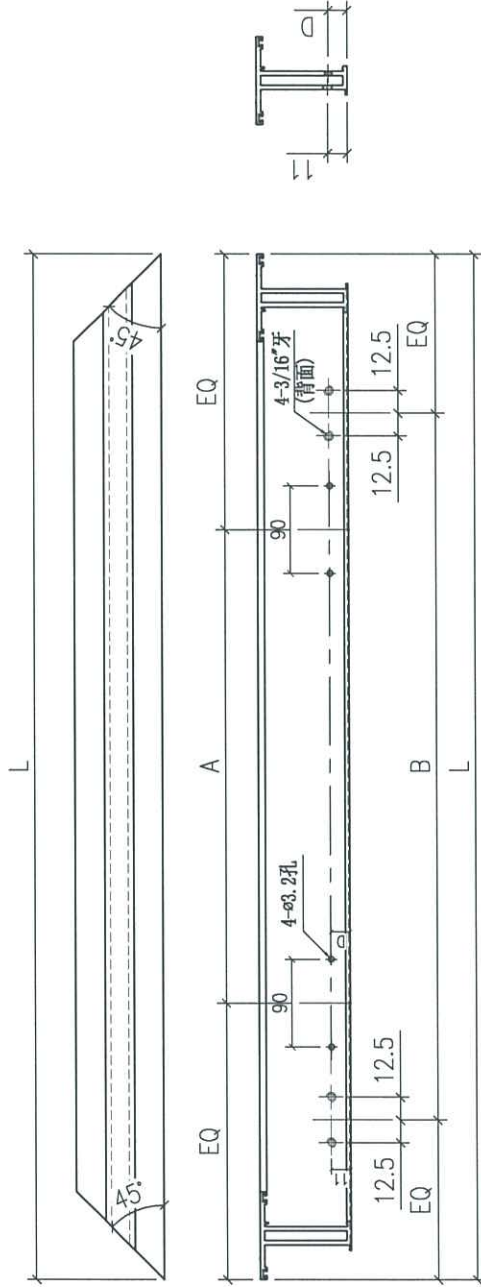

Remarks:	Checked: J.L.	Description: 窗玉料	QTY: 1	X86163-65A	1323	2x325c/c	823	8.5	1
Project Name: 康城11期	Date: 12-06-2024	Material: 6061-T5	Tolerance: ±0.5	部件编号	L	A	B	D	数量
Shop Drawing No. PRE-CAST ALUM. WINDOW & LOUVRE	Drawn: I.H.	Finish: PVF2	Factory	Delivery to Rev.	Date	Amendments			
Rev. -	Date: 12-06-2024		Projection:	Site	Assembly No.	Rev.			
						X86163-65			
						MIDI Aluminium Fabricator Ltd.			

FABRICATION DRAWING

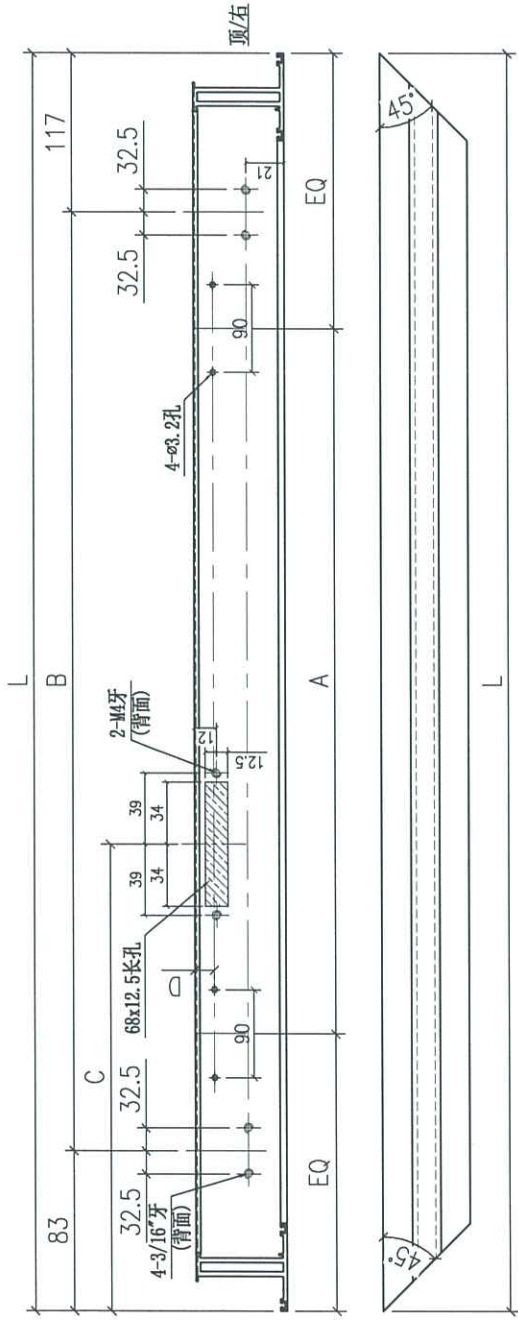
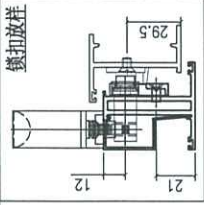

Remarks:		Checked: J.L.		Description: 窗玉料		1323		2x3250/c		@561.50/cx2		213		8.5		1	
Project Name: 康城11期		Date: 12-06-2024		Material: 6061-T5		L		A		B		C		D		数量	
Shop Drawing No. PRE-CAST ALUM. WINDOW & LOUVRE		Drawn: I.H.		Finish: PVF2		Delivery to		Rev.		Date		Amendments					
Rev. -		Date: 12-06-2024				Factory		Tolerance: ±0.5		Assembly No. X86163-66		Site		Rev.			

FABRICATION DRAWING

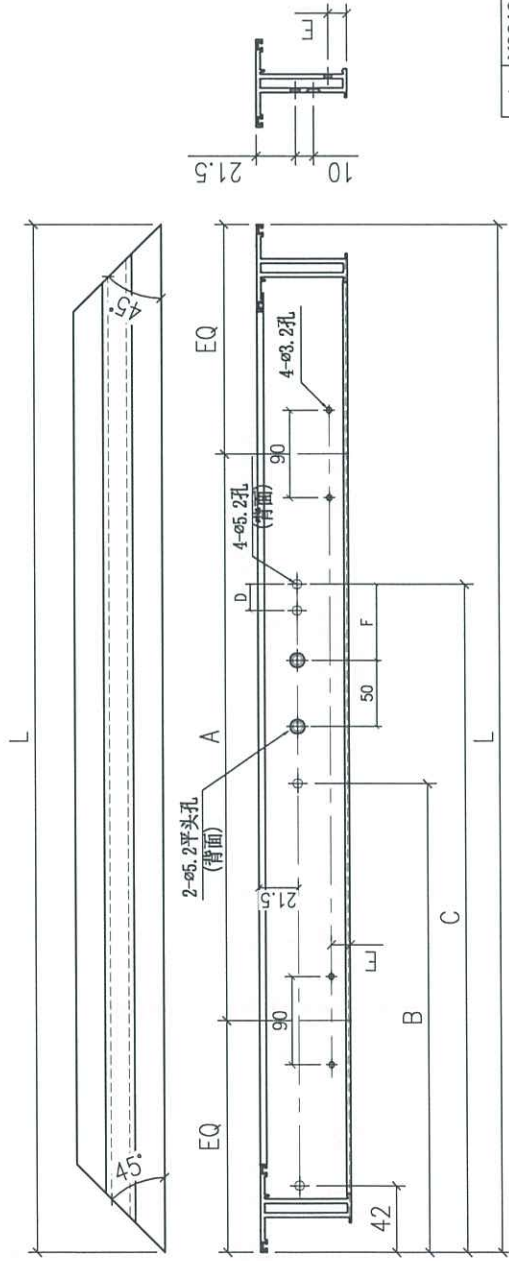

1	X86163-67LA	480	240	92	203.5	13.5	8.5	48.5	12"	1
序号	部件编号	L	A	B	C	D	E	F	扇撑	数量

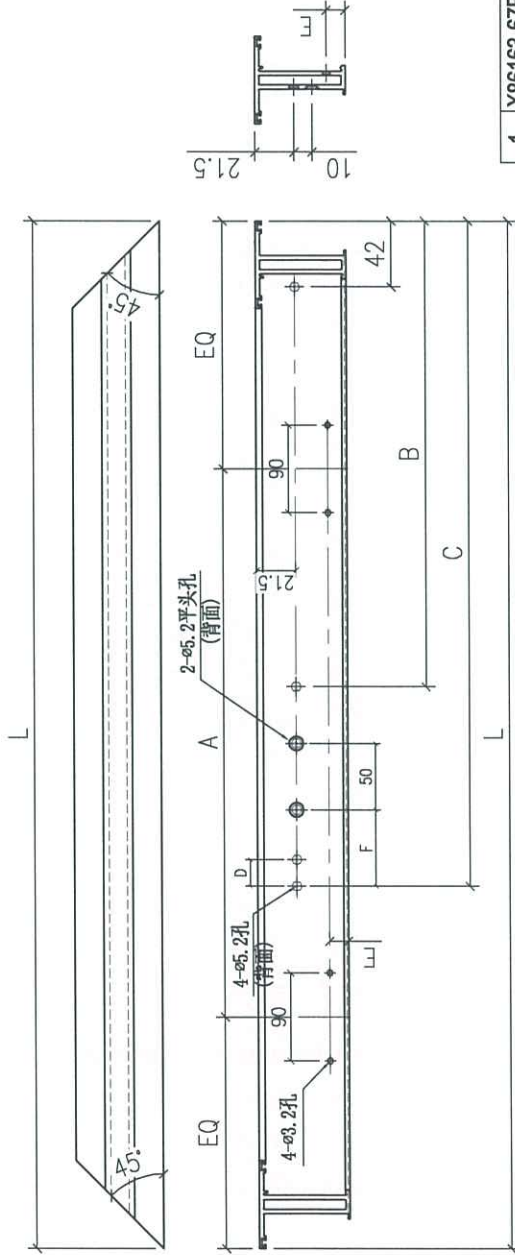

1	X86163-67RA	480	240	92	203.5	13.5	8.5	48.5	12"	1
序号	部件编号	L	A	B	C	D	E	F	扇撑	数量

Remarks:	Checked:	J.L.	Description:	窗玉料							
	Date:	12-06-2024	Material:	6061-T5							
Project No:	J858	Drawn:	I.H.	Finish:	PFV2						
Shop Drawing No.		Rev.		Assembly No.	X86163-67					Rev.	-

FABRICATION DRAWING

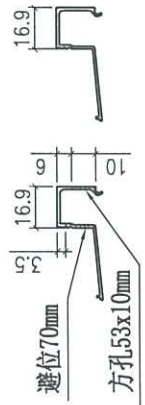
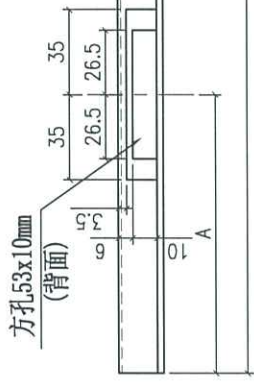
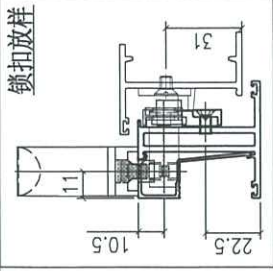

Remarks:

Project Name: 康城11期
PRE-CAST ALUM. WINDOW & LOUVRE

Project No. J858
Rev. -

Shop Drawing No. -

Checked: J.L.
Date: 12-06-2024
Drawn: I.H.
Date: 12-06-2024

Description: 13.52mm玻璃线

Material: 6061-T5

Finish: PVF2

QTY: -

Tolerance: ±0.5

Projection:

1	X86171-65A	1258.5	181	-	1
序号	部件编号	L	A	B	数量
Amendments					
Delivery to	Rev.	Date			
(Factory)					
Site			Assembly No. X86171-65		
			Rev.		

FABRICATION DRAWING

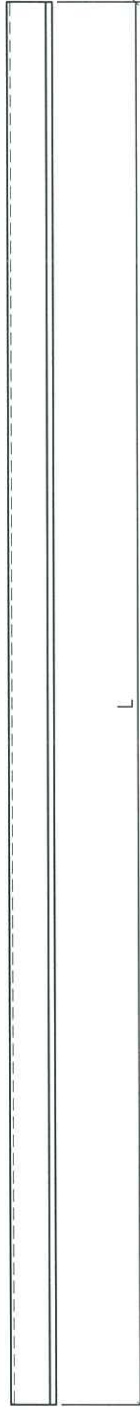
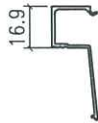

Remarks:		Checked: J.L.		Description: 13.52mm玻璃线		QTY: -		Delivery to Rev. Date		Amendments	
Project No. J858		Date: 12-06-2024		Material: 6061-T5		Tolerance: ±0.5		Factory		2 X86171-66B 383.5 - 1	
Rev. -		Drawn: I.H.		Finish: PVF2		Projection:		Site		1 X86171-66A 1258.5 - 1	
Shop Drawing No. PRE-CAST ALUM. WINDOW & LOUVRE		Date: 12-06-2024						Assembly No. X86171-66		Rev. 数量	

FABRICATION DRAWING

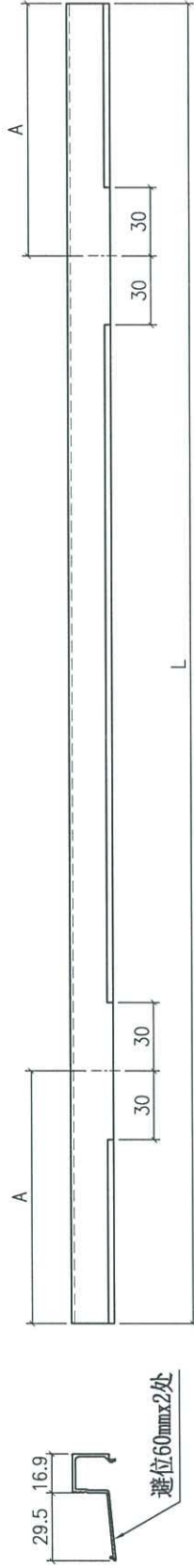

Remarks:

Project Name:

康城11期

Shop Drawing No.

PRE-CAST ALUM. WINDOW & LOUVRE

Checked:

J.L.

Date:

12-06-2024

Drawn:

I.H.

Date:

12-06-2024

Description:

13.52mm玻璃线

Material:

6061-T5

Finish:

PVF2

QTY:

-

Tolerance:

±0.5

Projection:



Delivery to

Rev.

Date

Factory

Site

Amendments

1

X86171-67A

383.5

L

A

数量

1

序号

1

部件编号

X86171-67

Assembly No.

Rev.

-

数量

1

FABRICATION DRAWING

序号	部件编号	L	A	数量
1	X86237-65A	123	47	17

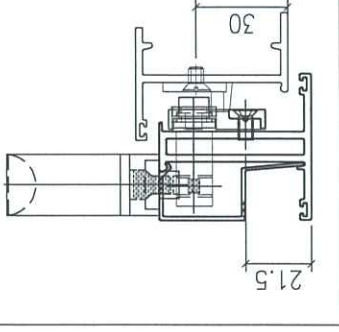
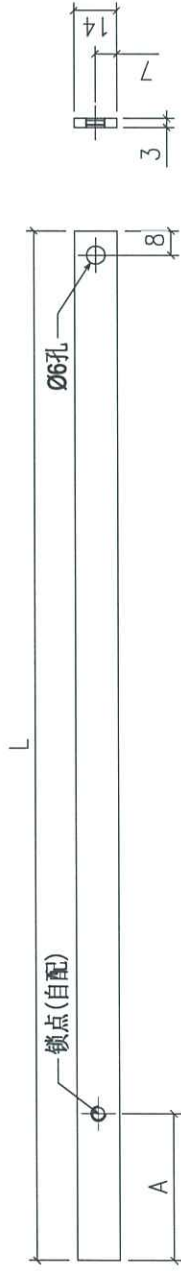

序号	部件编号	L	A	数量
1	X86237-65E	987	561.5	1

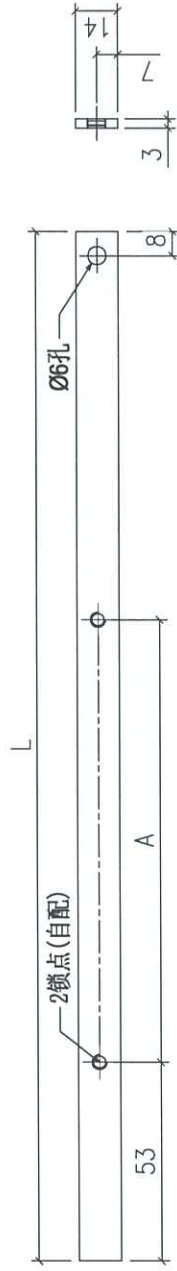

Remarks:		Checked: J.L.	Description: 拉巴加工图	QTY: -	Delivery to: Factory	Date	Amendments
Project Name: 康城11期		Date: 12-06-2024	Material: 14x3mm铝扁巴	Tolerance: ±0.5	Site		
Shop Drawing No. PRE-CAST ALUM. WINDOW & LOUVRE		Drawn: I.H.	Finish: PTF2	Projection:	Assembly No. X86237-65		
		Date: 12-06-2024			Rev. -		

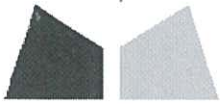

鋁材開料總表

工程號碼:新增后裝窗 工程名稱:J858

序號	鋁料編號	名稱	表面處理		開料長度	實用長料總數量		浪費率(%)
			顏色	層厚		支數	長度	
1	L065	15x15x3鋁角	鉻化		6000	1	6000	74.83
2	X86153	撞角碼	鉻化		6000	1	6000	95.77
3	X86154	拉巴用壓板1	ECD3X10 09 9S-		6000	1	6000	94.87
4	X86155	拉巴用壓板2	ECD3X10 09 9S-		6000	1	6000	97.07
5	X86163	窗玉橫	ECD3X10 09 9S-		6000	1	6000	38.67
6	X86171	窗玉玻璃綫企	ECD3X10 09 9S-		6000	1	6000	44.03
7	X86237	14x3拉巴	ECD3X10 09 9S-		6000	1	6000	80.47
8	X86251	邊企料	ECD3X10 09 9S-		5150	1	5150	45.67
9	X86252	生頂橫	ECD3X10 09 9S-		6000	1	6000	91.03
10	X86253	生底橫	ECD3X10 09 9S-		6000	1	6000	91.17

送至: _____

由: _____

日期: _____

簡短說明: _____

工程號碼:新增后裝窗, 工程名稱:J858

開料長度:6000, 總長料支數:1, 總開料支數:1

鋸片厚度(mm):6, 料頭尾總切除(mm):50, 浪費率(%):91.17

鋁材開料清單 X86253

窗號	編號(用料狀況)	實用長度(長料開數)	需要 支數	開料 支數	長料 支數	餘料 支數	編號(剩餘長度)
X86253-65A	1	474.0	1	1	1	0	1@(5470)x1



工程號碼:新增后裝窗, 工程名稱:J858

開料長度:6000, 總長料支數:1, 總開料支數:1

鋸片厚度(mm):6, 料頭尾總切除(mm):50, 浪費率(%):91.03

鋁材開料清單 X86252

窗號	編號(用料狀況)	實用長度(長料開數)	需要支數	開料支數	長料支數	餘料支數	編號(剩餘長度)
X86252-65	1	482.0	1	1	1	0	1@(5462)x1

工程號碼:新增后裝窗, 工程名稱:J858
 開料長度:5150, 總長料支數:1, 總開料支數:2
 鋸片厚度(mm):6, 料頭尾總切除(mm):50, 浪費率(%):45.67

鋁材開料清單 X86251

窗號	編號(用料狀況)	實用長度(長料開數)	需要支數	開料支數	長料支數	餘料支數	編號(剩餘長度)
X86251-66, X86251-65	(餘料)1, 1	1368.0	2	2	1	1	1@(2352)x1 1@(3726)x1

工程號碼: 新增后裝窗, 工程名稱: J858
 開料長度: 6000, 總長料支數: 1, 總開料支數: 2
 鋸片厚度(mm): 6, 料頭尾總切除(mm): 50, 浪費率(%): 80.47

鋁材開料清單 X86237

窗號	編號(用料狀況)	實用長度(長料開數)	需要支數	開料支數	長料支數	餘料支數	編號(剩餘長度)
X86237-65E	1	987.0	1	1	1	0	1@(4957)x1
X86237-65A	(餘料)1	123.0	1	1	0	1	1@(4828)x1

工程號碼:新增后裝窗, 工程名稱:J858
開料長度:6000, 總長料支數:1, 總開料支數:4
鋸片厚度(mm):6, 料頭尾總切除(mm):50, 浪費率(%):44.03

鋁材開料清單 X86171

窗號	編號(用料狀況)	實用長度(長料開數)	需要支數	開料支數	長料支數	餘料支數	編號(剩餘長度)
X86171-66A	(餘料)1	1258.5	2	1	0	1	1@(3421)x1
X86171-65A	1	1258.5		1	1	0	1@(4685.5)x1
X86171-66B, X86171-67A	(餘料)1, 1	383.5	2	2	0	2	1@(3031.5)x1 1@(2642)x1

工程號碼:新增后裝窗, 工程名稱:J858
開料長度:6000, 總長料支數:1, 總開料支數:4
鋸片厚度(mm):6, 料頭尾總切除(mm):50, 浪費率(%):38.67

鋁材開料清單 X86163

窗號	編號(用料狀況)	實用長度(長料開數)	需要 支數	開料 支數	長料 支數	餘料 支數	編號(剩餘長度)
X86163-66A	(餘料)1	1323.0	2	1	0	1	1@(3292)x1
X86163-65A	1	1323.0		1	1	0	1@(4621)x1
X86163-67LA, X86163-67LB	(餘料)1, 1	480.0	2	2	0	2	1@(2806)x1 1@(2320)x1

工程號碼:新增后裝窗, 工程名稱:J858
開料長度:6000, 總長料支數:1, 總開料支數:6
鋸片厚度(mm):6, 料頭尾總切除(mm):50, 浪費率(%):97.07

鋁材開料清單 X86155

窗號	編號(用料狀況)	實用長度(長料開數)	需要 支數	開料 支數	長料 支數	餘料 支數	編號(剩餘長度)
J858-LM67	1	15.0	6	6	1	0	1@(5824)x1

工程號碼:新增后裝窗, 工程名稱:J858

開料長度:6000, 總長料支數:1, 總開料支數:3

鋸片厚度(mm):6, 料頭尾總切除(mm):50, 浪費率(%):94.87

鋁材開料清單 X86154

窗號	編號(用料狀況)	實用長度(長料開數)	需要 支數	開料 支數	長料 支數	餘料 支數	編號(剩餘長度)
J858-LM66	1	80.0	3	3	1	0	1@(5692)x1

制表者: _____

工程號碼:新增后裝窗, 工程名稱:J858
開料長度:6000, 總長料支數:1, 總開料支數:10
鋸片厚度(mm):6, 料頭尾總切除(mm):50, 浪費率(%):74.83

鋁材開料清單 L065

窗號	編號(用料狀況)	實用長度(長料開數)	需要 支數	開料 支數	長料 支數	餘料 支數	編號(剩餘長度)
J858-LM68	1	140.0	10	10	1	0	1@(4490)x1