

工程指示 / 要求簡箋(E.I.)

工程指示編號：EI / 6407 / 23

修改版次： -

工程編號： J - 858

工程名稱：將軍澳日出康城 11

工程項目：幕牆 地盆用防水片 鉻化 地盤用 急送 6 件到地盤

收件人：生統

發件人：Ant Yeung

日期：29/06/2023

要求提供 / 確認 事項：

- () 初步鋁料 B.M. () 加工拆圖，然後生產 () 尺寸表
- () 正式鋁料 B.M. () 技術上資料 / 指示 () 報價
- () 配件 B.M. () 樣辦或貨品說明書 () 分判合約

內容：

按現場判頭需要，隔火層露台乾底下的防水片，(預直)：

請按加工圖生產防水片送地盆用，

FS-10-CAN 1.5mm 厚，所有防水片需鉻化，共 200 件

急送 6 件到地盤

分座分層打扎

→ 銀磚，阻折棚☆

請在 2023.07.07 前完成上列要求。

分發東莞各部門：

- () 生產技術總監 連附件 () 技術部 連附件 () 生產部 連附件 () 機械設計部 連附件
- () 採購部 連附件 (✓) 生產統籌部 連附件 (✓) 小羅&清 連附件
- () 質檢部 連附件 () 會計部 連附件 () 報關組 連附件 () 其他 _____ 連附件

分發香港各部門：

- () 行政部 連附件 () 會計部 連附件 () 統籌部 連附件 (✓) 工程部地盤科文 積哥, 二寶 連附件
- () 採購部 連附件 () QS 部 連附件 () 維修部 連附件 () 其他 _____ 連附件

傳遞編號：

HK 1451 / 23

發件人簽署：

(Signature)

項目經理簽署：

(Signature)

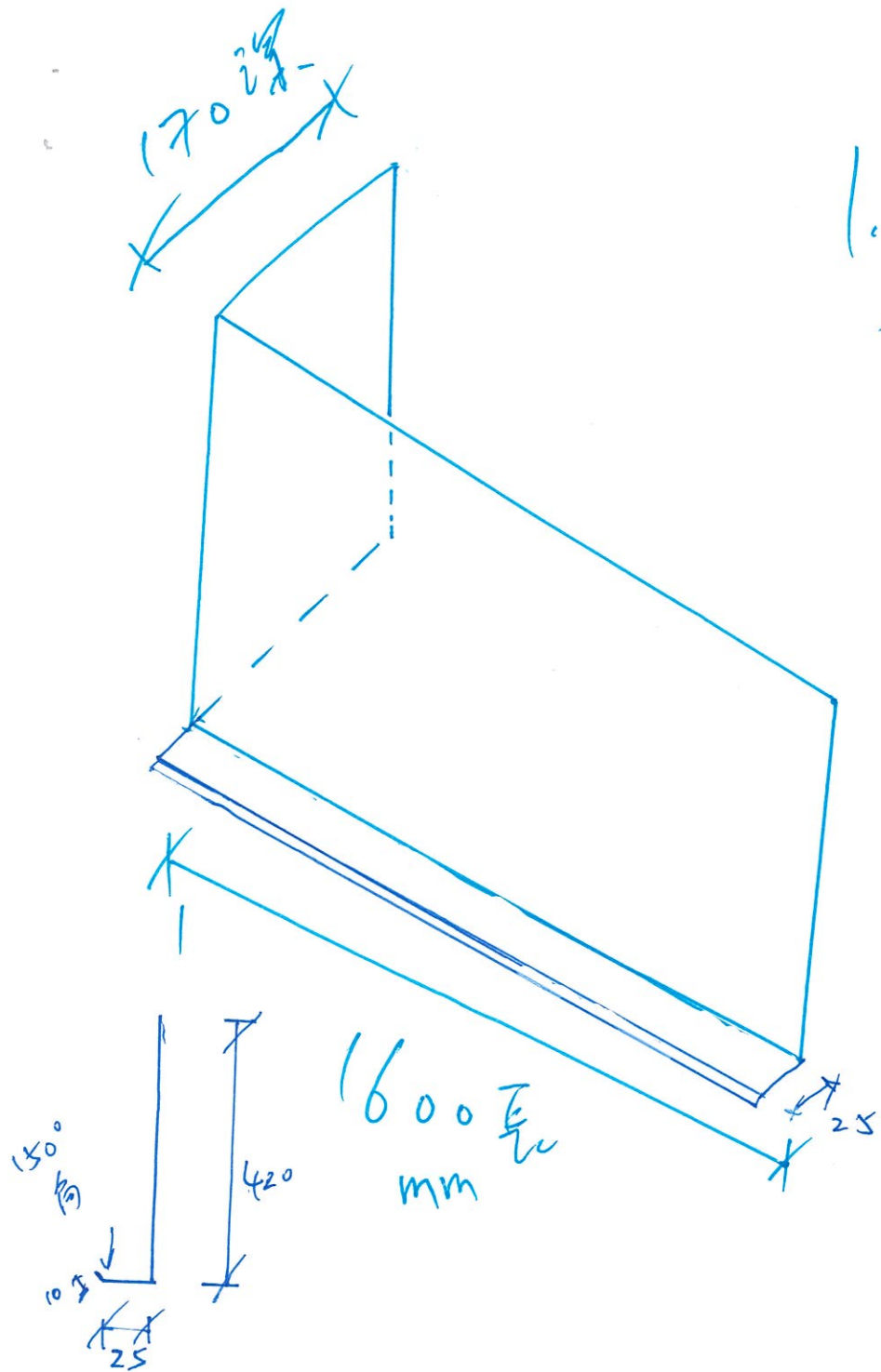

1.8 mm
~~1.8 mm~~

FS-10-CAN

已拉直, 下与左右用.

	14T	60T	54
T1	26	26	10
(已修整) T2	26	26	10
T3	26	26	10

高度 420 mm

与层与层对齐

先出6件在急

共 1814

+ 1414

共 20014

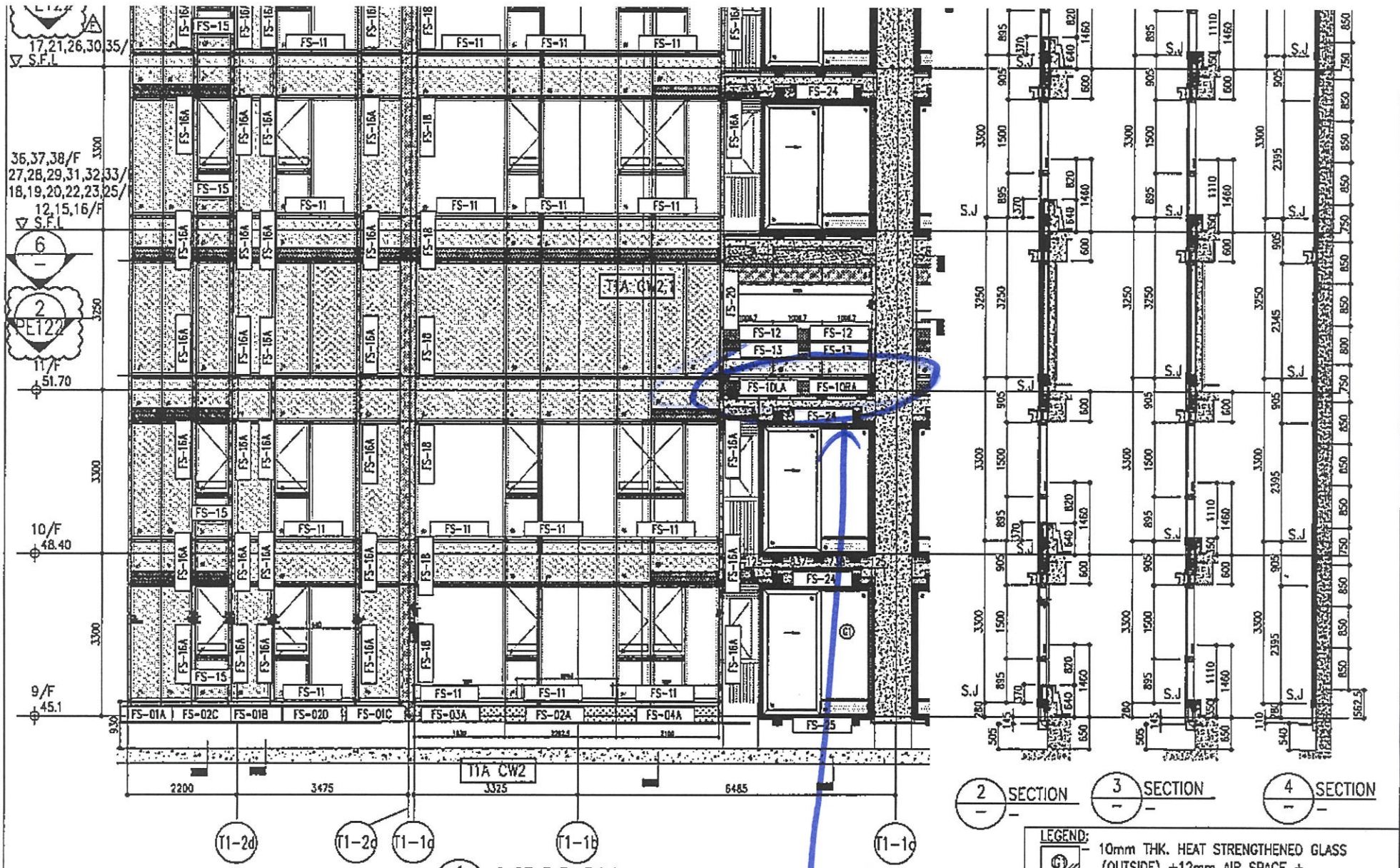

窗台單元底下

17,21,26,30,35/
▽ S.F.L

36,37,38/F
27,28,29,31,32,33/
18,19,20,22,23,25/
12,15,16/F
▽ S.F.L

6
-
PET22

11/F
51.70

10/F
48.40

9/F
45.1

2200 3475 3375 6485

T1-2d T1-2c T1-1c T1-1b T1-1a

2 SECTION
3 SECTION
4 SECTION

LEGEND:
10mm THK. HEAT STRENGTHENED GLASS (OUTSIDE) + 12mm AIR SPACE +

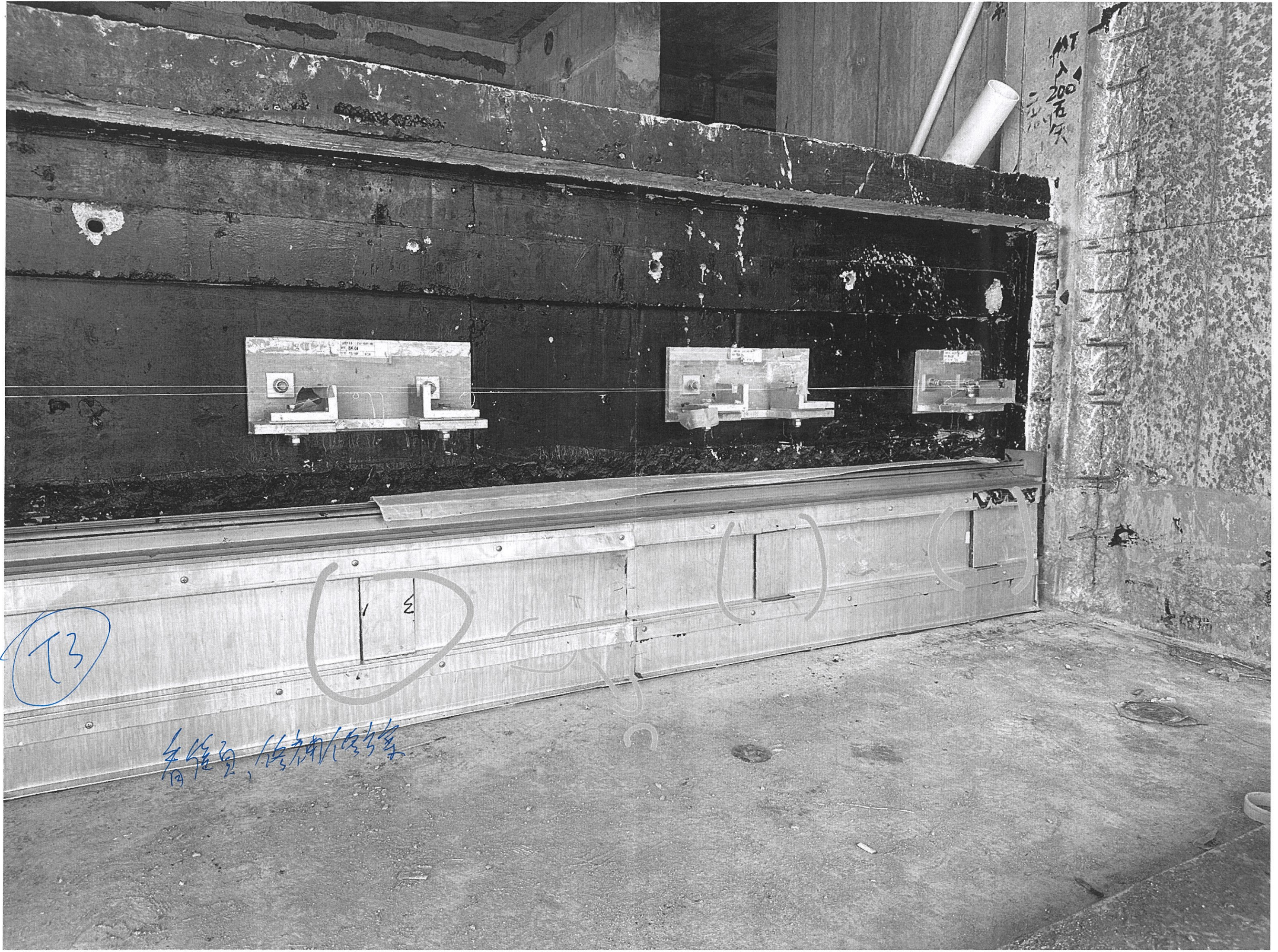

T3

手推車, 供料/送料

MT
200
五

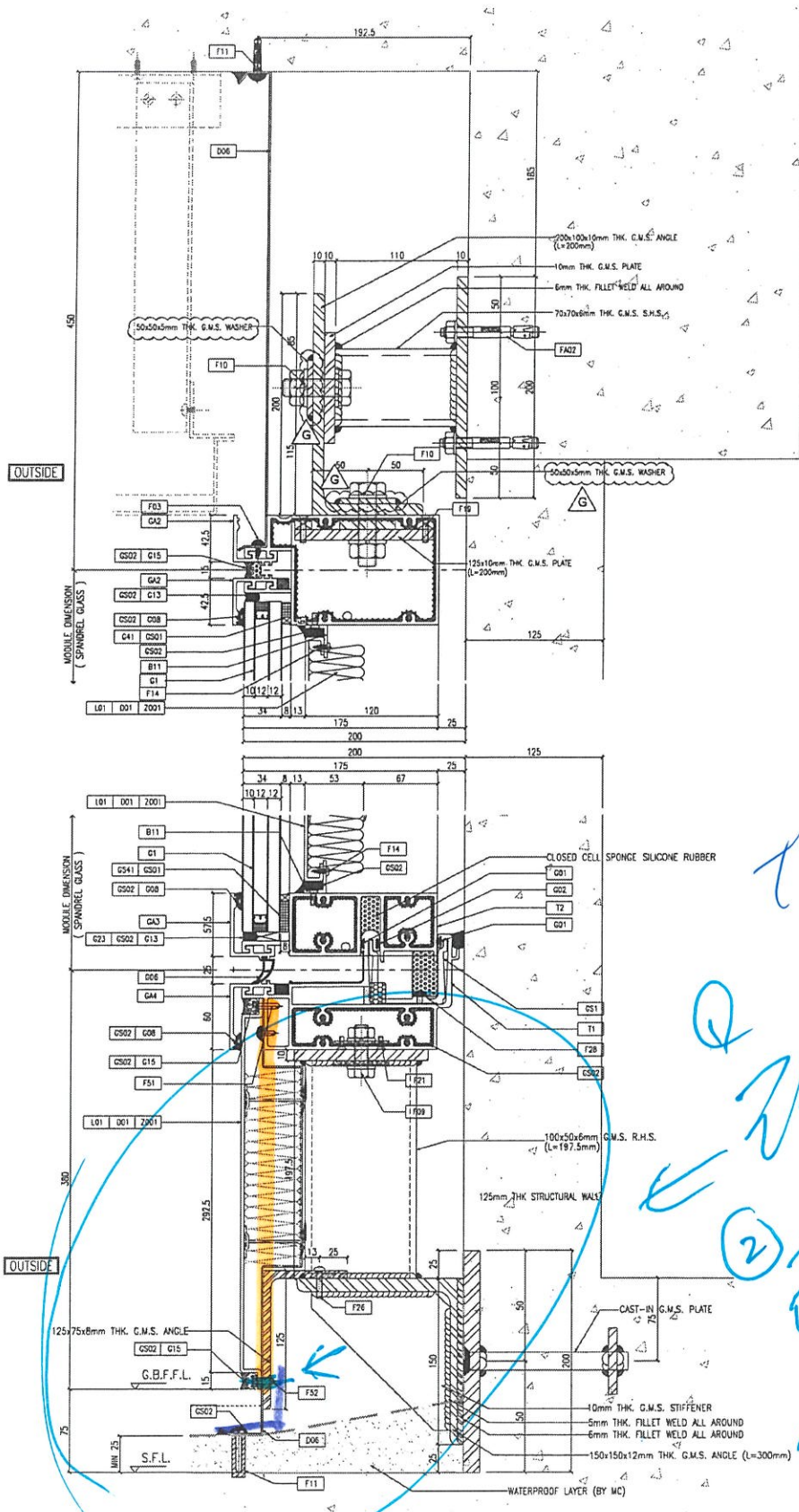

1 TYPICAL TRANSOM DETAIL
D56 CURTAIN WALL

2 TYPICAL TRANSOM DETAIL
D56 CURTAIN WALL

Handwritten blue notes and arrows on drawing 2:

- ① 玻璃 (Glass)
- ② 玻璃板 (Glass panel)
- ③ 玻璃 (Glass)

<p>DATE: 22-01-21 SCALE: 1:2(A1)</p> <p>DRAWN BY: [] CHECKED BY: []</p> <p>PROJECT: PROPOSED RECONSTRUCTION DEVELOPMENT AT KOOL JOSE, PHASE 11, LOHAS PARK, TSEUNG KWAN O, N.T.</p> <p>JOB NO.: J-858</p>	<p>REVISIONS:</p> <table border="1"> <tr><th>NO.</th><th>DATE</th><th>REVISION</th></tr> <tr><td>0</td><td>12/01/21</td><td>ISSUED AS PER COMMENTS</td></tr> <tr><td>1</td><td>23/01/21</td><td>ISSUED AS PER COMMENTS</td></tr> <tr><td>2</td><td>23/01/21</td><td>ISSUED AS PER COMMENTS</td></tr> <tr><td>3</td><td>23/01/21</td><td>ISSUED AS PER COMMENTS</td></tr> <tr><td>4</td><td>23/01/21</td><td>ISSUED AS PER COMMENTS</td></tr> <tr><td>5</td><td>23/01/21</td><td>ISSUED AS PER COMMENTS</td></tr> <tr><td>6</td><td>23/01/21</td><td>ISSUED AS PER COMMENTS</td></tr> <tr><td>7</td><td>23/01/21</td><td>ISSUED AS PER COMMENTS</td></tr> <tr><td>8</td><td>23/01/21</td><td>ISSUED AS PER COMMENTS</td></tr> <tr><td>9</td><td>23/01/21</td><td>ISSUED AS PER COMMENTS</td></tr> <tr><td>10</td><td>23/01/21</td><td>ISSUED AS PER COMMENTS</td></tr> <tr><td>11</td><td>23/01/21</td><td>ISSUED AS PER COMMENTS</td></tr> <tr><td>12</td><td>23/01/21</td><td>ISSUED AS PER COMMENTS</td></tr> <tr><td>13</td><td>23/01/21</td><td>ISSUED AS PER COMMENTS</td></tr> <tr><td>14</td><td>23/01/21</td><td>ISSUED AS PER COMMENTS</td></tr> <tr><td>15</td><td>23/01/21</td><td>ISSUED AS PER COMMENTS</td></tr> <tr><td>16</td><td>23/01/21</td><td>ISSUED AS PER COMMENTS</td></tr> <tr><td>17</td><td>23/01/21</td><td>ISSUED AS PER COMMENTS</td></tr> <tr><td>18</td><td>23/01/21</td><td>ISSUED AS PER COMMENTS</td></tr> <tr><td>19</td><td>23/01/21</td><td>ISSUED AS PER COMMENTS</td></tr> <tr><td>20</td><td>23/01/21</td><td>ISSUED AS PER COMMENTS</td></tr> </table>	NO.	DATE	REVISION	0	12/01/21	ISSUED AS PER COMMENTS	1	23/01/21	ISSUED AS PER COMMENTS	2	23/01/21	ISSUED AS PER COMMENTS	3	23/01/21	ISSUED AS PER COMMENTS	4	23/01/21	ISSUED AS PER COMMENTS	5	23/01/21	ISSUED AS PER COMMENTS	6	23/01/21	ISSUED AS PER COMMENTS	7	23/01/21	ISSUED AS PER COMMENTS	8	23/01/21	ISSUED AS PER COMMENTS	9	23/01/21	ISSUED AS PER COMMENTS	10	23/01/21	ISSUED AS PER COMMENTS	11	23/01/21	ISSUED AS PER COMMENTS	12	23/01/21	ISSUED AS PER COMMENTS	13	23/01/21	ISSUED AS PER COMMENTS	14	23/01/21	ISSUED AS PER COMMENTS	15	23/01/21	ISSUED AS PER COMMENTS	16	23/01/21	ISSUED AS PER COMMENTS	17	23/01/21	ISSUED AS PER COMMENTS	18	23/01/21	ISSUED AS PER COMMENTS	19	23/01/21	ISSUED AS PER COMMENTS	20	23/01/21	ISSUED AS PER COMMENTS	<p>LEGEND:</p> <p>① OCTAL MARK NO.</p> <p>② REFER SHEET NO.</p> <p>③ F.F.L. -- FINISHED FLOOR LEVEL</p> <p>④ S.F.L. -- STRUCTURAL FLOOR LEVEL</p> <p>⑤ -- REVERSED DETAIL</p>	<p>NOTE:</p> <p>1. ALL DIMENSIONS ARE IN mm.</p> <p>2. ALL DIMENSIONS ARE TAKEN FROM OUTSIDE.</p> <p>3. FINISHES TO BE REFERRED ON SITE.</p> <p>4. FINISHES TO BE REFERRED ON SITE.</p>	<p>FRACOE CONSULTANTS:</p> <p>AECOM</p> <p>STRUCTURAL ENGINEER:</p> <p>Gammon</p>	<p>ARCHITECT:</p> <p>ronald lu & partners</p> <p>Project Architect & Consultant 隆利建築師事務所 (隆利) 有限公司 香港中環皇后大道中15號15樓1501室</p>	<p>CLIENT:</p> <p>佳和置業有限公司 Sino Land Company Limited</p>	<p>B.O. REF:</p>
		NO.	DATE	REVISION																																																																					
0	12/01/21	ISSUED AS PER COMMENTS																																																																							
1	23/01/21	ISSUED AS PER COMMENTS																																																																							
2	23/01/21	ISSUED AS PER COMMENTS																																																																							
3	23/01/21	ISSUED AS PER COMMENTS																																																																							
4	23/01/21	ISSUED AS PER COMMENTS																																																																							
5	23/01/21	ISSUED AS PER COMMENTS																																																																							
6	23/01/21	ISSUED AS PER COMMENTS																																																																							
7	23/01/21	ISSUED AS PER COMMENTS																																																																							
8	23/01/21	ISSUED AS PER COMMENTS																																																																							
9	23/01/21	ISSUED AS PER COMMENTS																																																																							
10	23/01/21	ISSUED AS PER COMMENTS																																																																							
11	23/01/21	ISSUED AS PER COMMENTS																																																																							
12	23/01/21	ISSUED AS PER COMMENTS																																																																							
13	23/01/21	ISSUED AS PER COMMENTS																																																																							
14	23/01/21	ISSUED AS PER COMMENTS																																																																							
15	23/01/21	ISSUED AS PER COMMENTS																																																																							
16	23/01/21	ISSUED AS PER COMMENTS																																																																							
17	23/01/21	ISSUED AS PER COMMENTS																																																																							
18	23/01/21	ISSUED AS PER COMMENTS																																																																							
19	23/01/21	ISSUED AS PER COMMENTS																																																																							
20	23/01/21	ISSUED AS PER COMMENTS																																																																							
<p>UNITED ARCHITECTS:</p> <p>MIDI ARCHITECTURE ASSOCIATES LTD.</p> <p>Units 6-8, Sunny Industrial Centre, Y/F 510 Chee Koo Ling Road, Kowloon TEL: 24682711-4 FAX: (852) 27272855</p> <p>DATE: 05-09-09 REV: 0</p>																																																																									

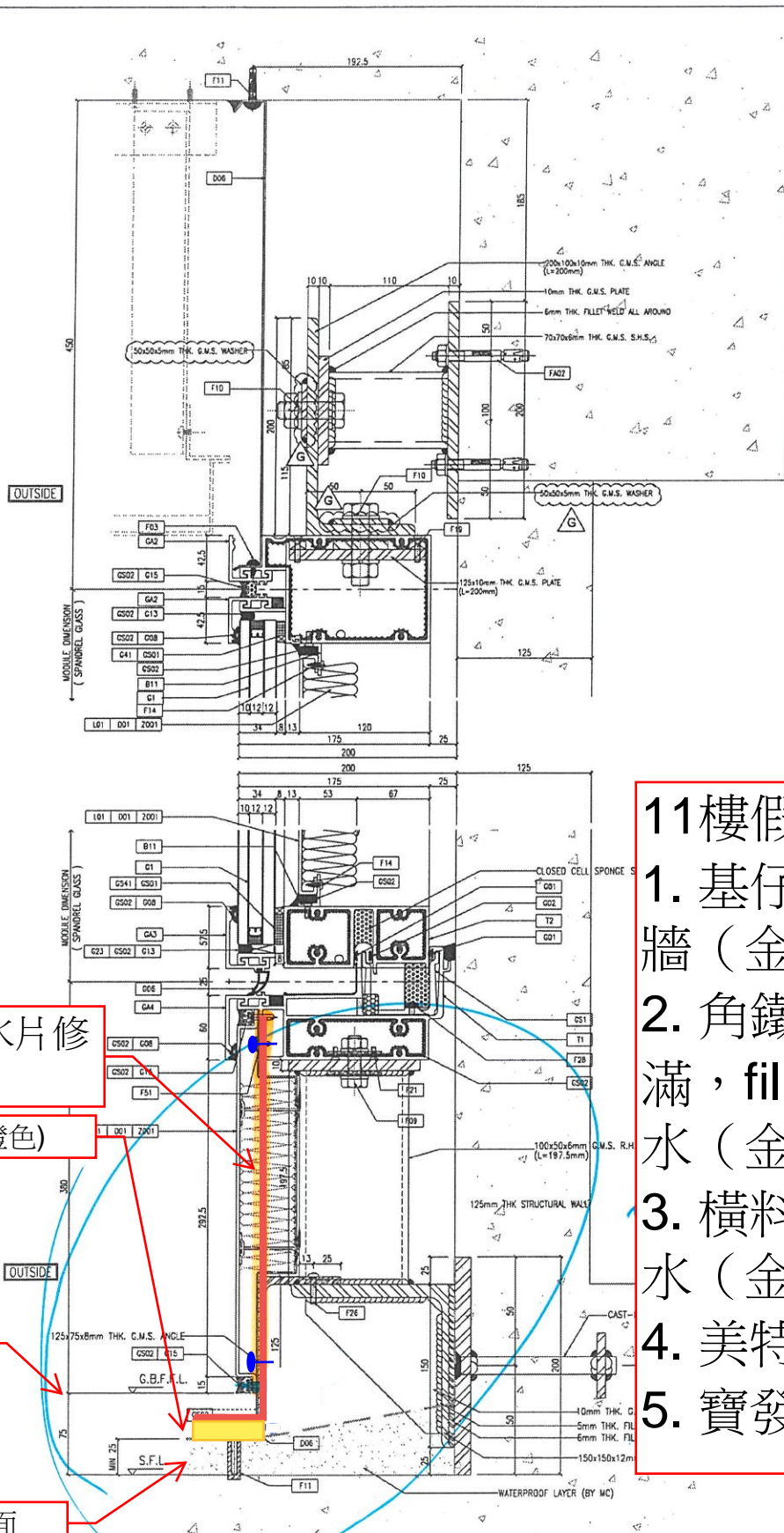

1 TYPICAL TRANSOM DETAIL CURTAIN WALL

2 TYPICAL TRANSOM DETAIL CURTAIN WALL

- 11樓假露台工序：
1. 基仔落至碰矮牆（金門）
 2. 角鐵至基仔之間填滿，fill平角鐵免積水（金門）
 3. 橫料底做斜面免積水（金門）
 4. 美特防水片
 5. 寶發防水片

4. Midi 防水片修在鐵面
4. 壓膠（螢光橙色）

1. 基仔

2&3. 防水和做斜面

<p>DATE: 22-01-21 SCALE: 1:2(A1)</p> <p>DRAWN BY: CHECKED BY:</p> <p>UNIT: 6-8, Sunny Industrial Centre, Y/T</p> <p>510 Chee Koo Ling Road, Kowloon</p> <p>TEL: 23498211-4 FAX: 23272728</p> <p>DMC NO.: 0559-CW-056</p> <p>REV.: 0</p>	<p>TITLE: TYPICAL MULLION DETAIL FOR CURTAIN WALL</p> <p>PROJECT: PROPOSED REDEVELOPMENT AT KOWLOON PARK, PHASE 11, LOHAS PARK, TSEUNG KWAN O, N.T.</p> <p>JOB NO.: J-858</p>	<p>REVISIONS:</p> <table border="1"> <tr><th>NO.</th><th>DATE</th><th>REVISION</th></tr> <tr><td>0</td><td>12/01/21</td><td>ISSUED AS PER COMMENTS</td></tr> <tr><td>1</td><td>23/01/21</td><td>ISSUED AS PER COMMENTS</td></tr> <tr><td>2</td><td>23/01/21</td><td>ISSUED AS PER COMMENTS</td></tr> <tr><td>3</td><td>23/01/21</td><td>ISSUED AS PER COMMENTS</td></tr> <tr><td>4</td><td>23/01/21</td><td>ISSUED AS PER COMMENTS</td></tr> <tr><td>5</td><td>23/01/21</td><td>ISSUED AS PER COMMENTS</td></tr> <tr><td>6</td><td>23/01/21</td><td>ISSUED AS PER COMMENTS</td></tr> <tr><td>7</td><td>23/01/21</td><td>ISSUED AS PER COMMENTS</td></tr> <tr><td>8</td><td>23/01/21</td><td>ISSUED AS PER COMMENTS</td></tr> <tr><td>9</td><td>23/01/21</td><td>ISSUED AS PER COMMENTS</td></tr> <tr><td>10</td><td>23/01/21</td><td>ISSUED AS PER COMMENTS</td></tr> <tr><td>11</td><td>23/01/21</td><td>ISSUED AS PER COMMENTS</td></tr> <tr><td>12</td><td>23/01/21</td><td>ISSUED AS PER COMMENTS</td></tr> <tr><td>13</td><td>23/01/21</td><td>ISSUED AS PER COMMENTS</td></tr> <tr><td>14</td><td>23/01/21</td><td>ISSUED AS PER COMMENTS</td></tr> <tr><td>15</td><td>23/01/21</td><td>ISSUED AS PER COMMENTS</td></tr> <tr><td>16</td><td>23/01/21</td><td>ISSUED AS PER COMMENTS</td></tr> <tr><td>17</td><td>23/01/21</td><td>ISSUED AS PER COMMENTS</td></tr> <tr><td>18</td><td>23/01/21</td><td>ISSUED AS PER COMMENTS</td></tr> <tr><td>19</td><td>23/01/21</td><td>ISSUED AS PER COMMENTS</td></tr> <tr><td>20</td><td>23/01/21</td><td>ISSUED AS PER COMMENTS</td></tr> </table>	NO.	DATE	REVISION	0	12/01/21	ISSUED AS PER COMMENTS	1	23/01/21	ISSUED AS PER COMMENTS	2	23/01/21	ISSUED AS PER COMMENTS	3	23/01/21	ISSUED AS PER COMMENTS	4	23/01/21	ISSUED AS PER COMMENTS	5	23/01/21	ISSUED AS PER COMMENTS	6	23/01/21	ISSUED AS PER COMMENTS	7	23/01/21	ISSUED AS PER COMMENTS	8	23/01/21	ISSUED AS PER COMMENTS	9	23/01/21	ISSUED AS PER COMMENTS	10	23/01/21	ISSUED AS PER COMMENTS	11	23/01/21	ISSUED AS PER COMMENTS	12	23/01/21	ISSUED AS PER COMMENTS	13	23/01/21	ISSUED AS PER COMMENTS	14	23/01/21	ISSUED AS PER COMMENTS	15	23/01/21	ISSUED AS PER COMMENTS	16	23/01/21	ISSUED AS PER COMMENTS	17	23/01/21	ISSUED AS PER COMMENTS	18	23/01/21	ISSUED AS PER COMMENTS	19	23/01/21	ISSUED AS PER COMMENTS	20	23/01/21	ISSUED AS PER COMMENTS	<p>NOTES:</p> <ol style="list-style-type: none"> 1. ALL DIMENSIONS ARE IN mm. 2. ALL DIMENSIONS ARE TAKEN FROM OUTSIDE. 3. FINISHES TO BE VERIFIED ON SITE. 4. FINISHES TO BE VERIFIED ON SITE. 5. FINISHES TO BE VERIFIED ON SITE. <p>LEGEND:</p> <p>Ø - OCTAL MARK NO.</p> <p>REF - REFER SHEET NO.</p> <ol style="list-style-type: none"> 1. F.F.L. - FINISHED FLOOR LEVEL 2. S.F.L. - STRUCTURAL FLOOR LEVEL 3. - - - REVERSED DETAIL 	<p>FRACOE CONSULTANT:</p> <p>AECOM</p> <p>STRUCTURAL ENGINEER:</p> <p>Gammron</p> <p>ARCHITECT:</p> <p>ronald lu & partners</p> <p>Project Architect & Partner</p> <p>10/F, Sunny Industrial Centre, Y/T</p> <p>510 Chee Koo Ling Road, Kowloon</p> <p>TEL: 23498211-4 FAX: 23272728</p> <p>MAIN CONTRACTOR:</p> <p>Sino Land Company Limited</p>	<p>B.O. REF:</p>
NO.	DATE	REVISION																																																																					
0	12/01/21	ISSUED AS PER COMMENTS																																																																					
1	23/01/21	ISSUED AS PER COMMENTS																																																																					
2	23/01/21	ISSUED AS PER COMMENTS																																																																					
3	23/01/21	ISSUED AS PER COMMENTS																																																																					
4	23/01/21	ISSUED AS PER COMMENTS																																																																					
5	23/01/21	ISSUED AS PER COMMENTS																																																																					
6	23/01/21	ISSUED AS PER COMMENTS																																																																					
7	23/01/21	ISSUED AS PER COMMENTS																																																																					
8	23/01/21	ISSUED AS PER COMMENTS																																																																					
9	23/01/21	ISSUED AS PER COMMENTS																																																																					
10	23/01/21	ISSUED AS PER COMMENTS																																																																					
11	23/01/21	ISSUED AS PER COMMENTS																																																																					
12	23/01/21	ISSUED AS PER COMMENTS																																																																					
13	23/01/21	ISSUED AS PER COMMENTS																																																																					
14	23/01/21	ISSUED AS PER COMMENTS																																																																					
15	23/01/21	ISSUED AS PER COMMENTS																																																																					
16	23/01/21	ISSUED AS PER COMMENTS																																																																					
17	23/01/21	ISSUED AS PER COMMENTS																																																																					
18	23/01/21	ISSUED AS PER COMMENTS																																																																					
19	23/01/21	ISSUED AS PER COMMENTS																																																																					
20	23/01/21	ISSUED AS PER COMMENTS																																																																					

DE

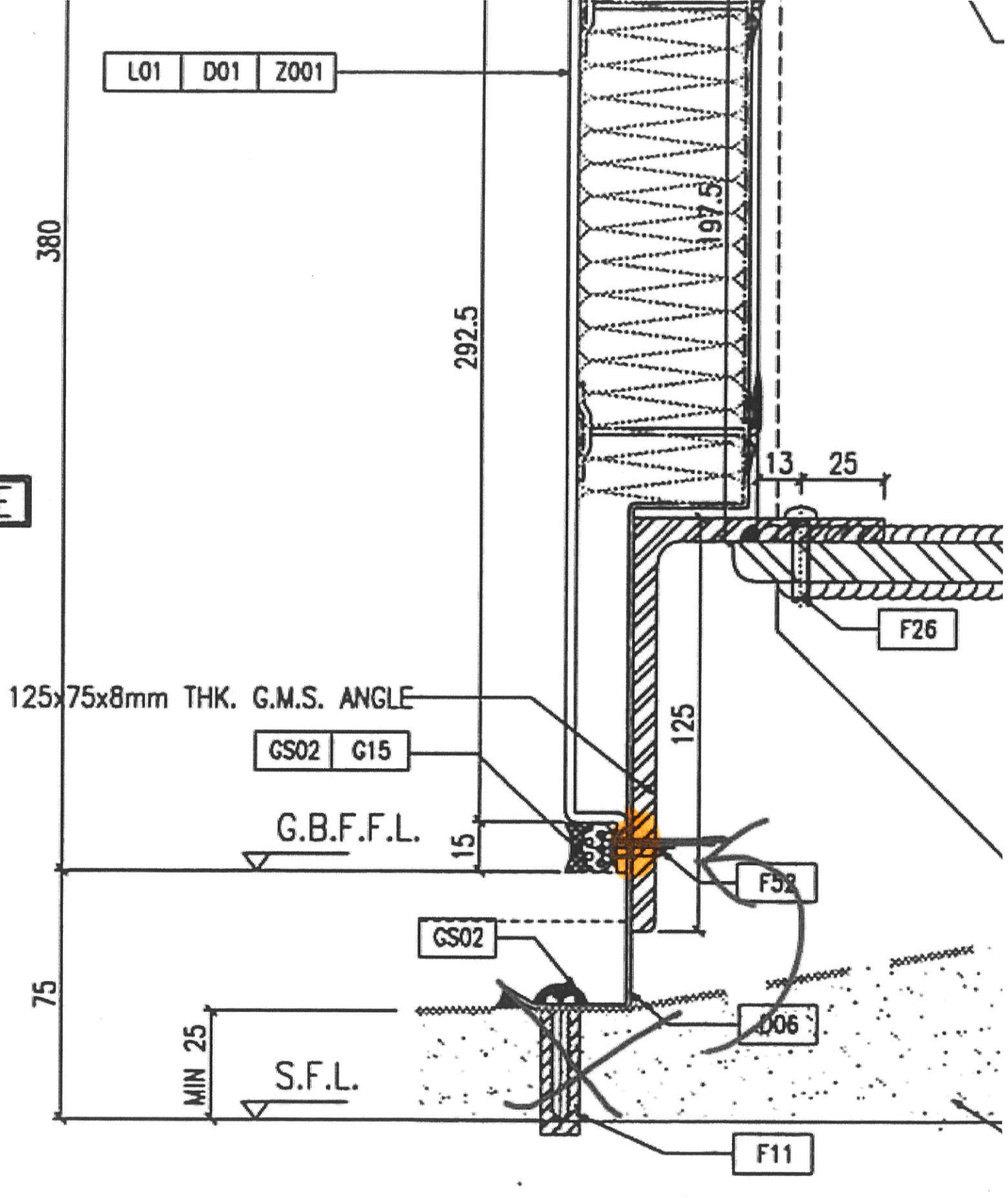

2. S.F.L.
 3. (R)

G	12/0
F	28/0
E	25/0
D	25/0
C	07/0
B	25/0
A	23/1
NO.	DATE

JOB NO.
 PROJECT P1
 AT

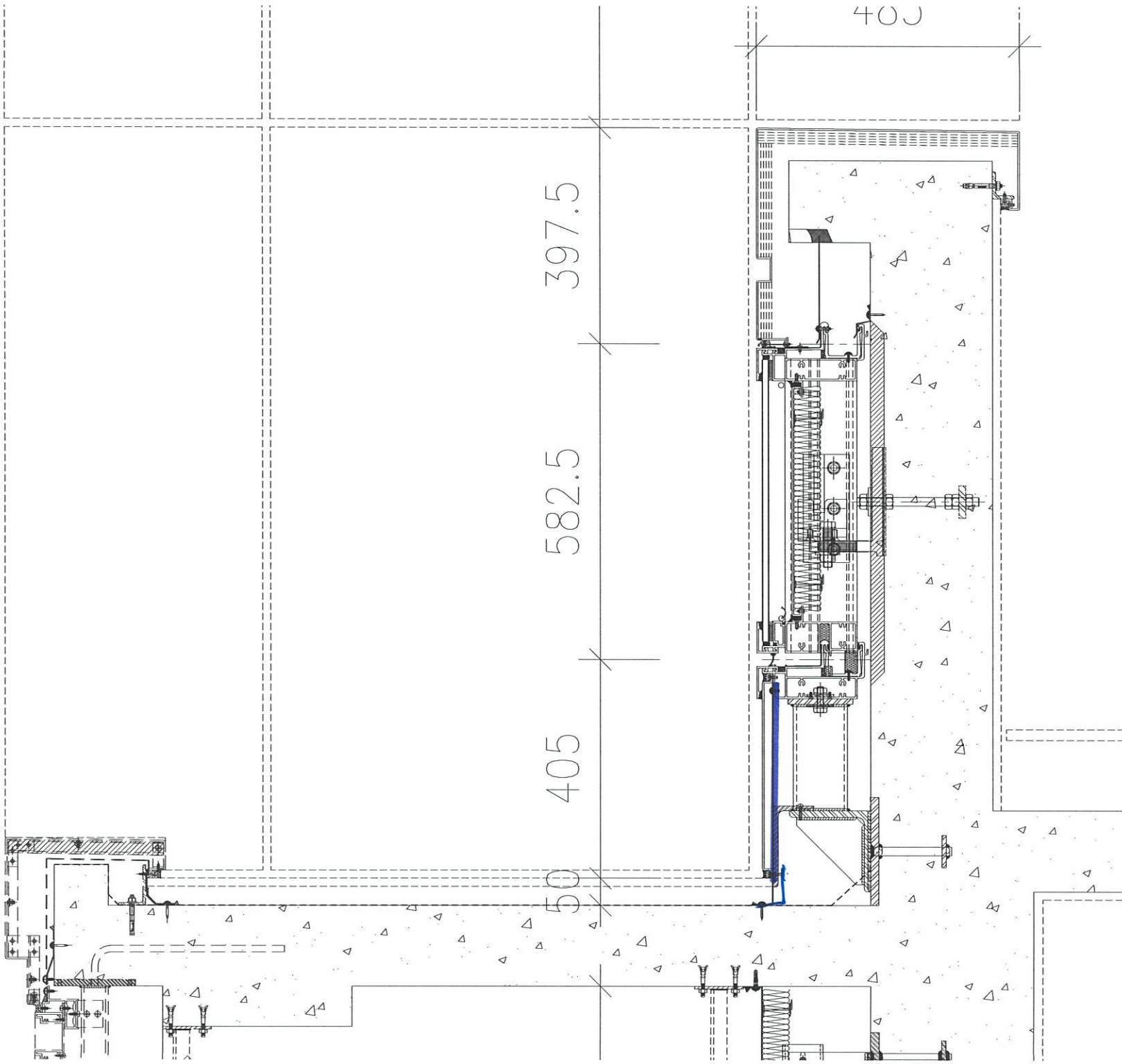

 美特铝质有限公司 MIDI Aluminium Fabricator Ltd.				工程號	J858	類別		物料號	-			
				地盘	康城11期	制圖	W. E. X	2022-08-11	圖號	FS-10R		
修改	-	-	-	採用工廠	✓	地盤	圖紙名稱	铝防水板加工图	復核	-	數量	-
日期	-	-	-	材料颜色	CHROMATE	/	材料	1.5mm THK. 铝板	批准	-	單件重量	- (KG)

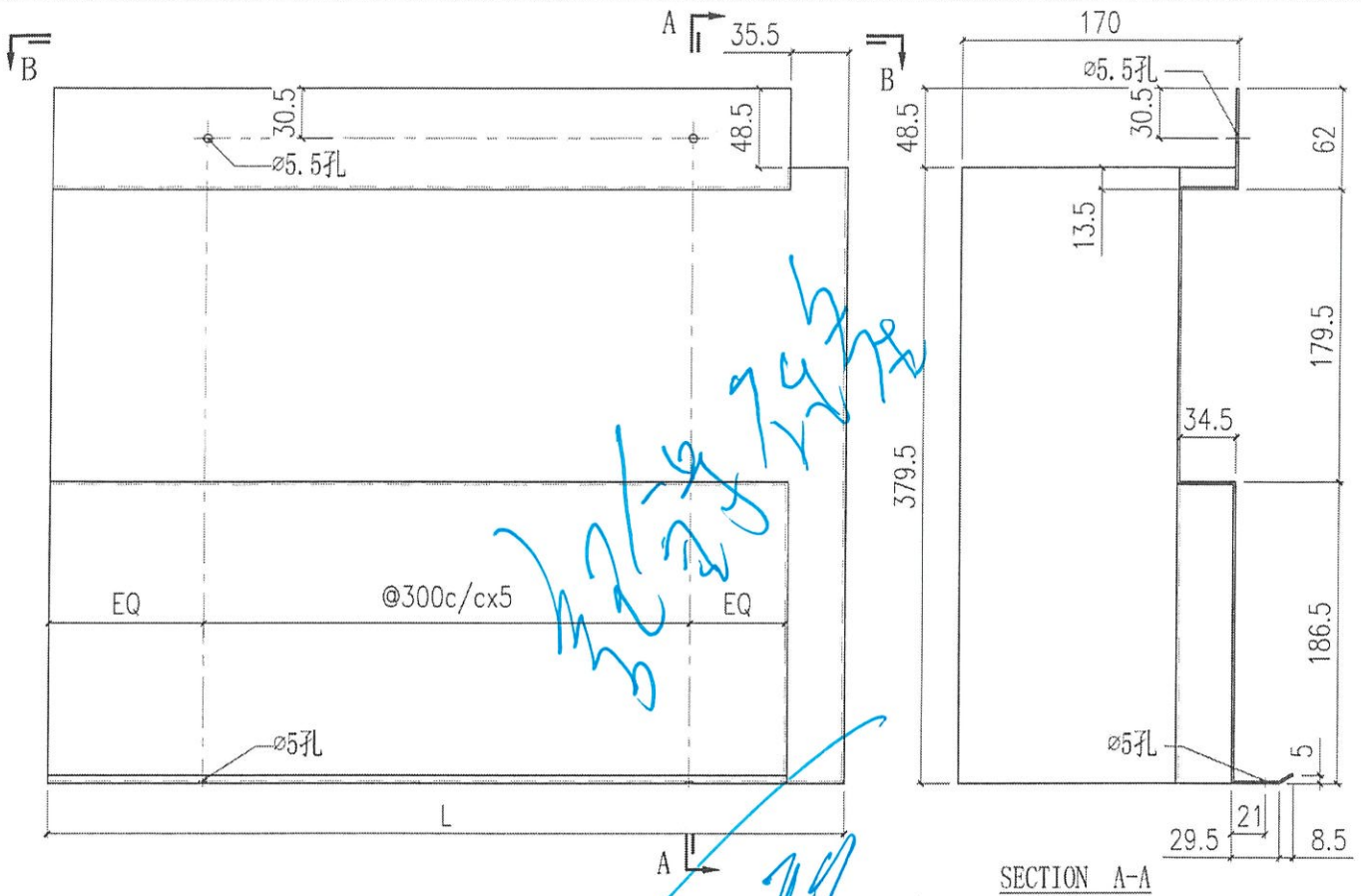

SECTION A-A

SECTION B-B

FS-10RA	1600	T3A-CW8 (SU)	67/F	1	15
		T3B-CW10 (SU)	67/F	1	
		T3B-CW9 (SU)	67/F	1	
		T3B-CW7 (SU)	67/F	1	
		T3A-CW7 (SU)	67/F	1	
		T2A-CW10 (SU)	67/F	1	
		T2B-CW10 (SU)	67/F	1	
		T2B-CW9 (SU)	67/F	1	
		T2B-CW7 (SU)	67/F	1	
		T2A-CW6 (SU)	67/F	1	
		T1A-CW11 (SU)	62/F	1	
		T1B-CW9 (SU)	62/F	1	
		T1B-CW8 (SU)	62/F	1	
		T1B-CW6 (SU)	62/F	1	
		T1A-CW7 (SU)	62/F	1	
编号	L	位置	楼层	数量	合计

FS-10RA	1600	T3A-CW3.1	4	26
		T3A-CW4.1	2	
		T3A-CW5.1	2	
		T3B-CW6.1	4	
		T3B-CW5.1	2	
		T3B-CW4.1	2	
		T3B-CW3.1	2	
		T3B-CW2.1	2	
		T3B-CW1.1	2	
		T3A-CW1.1	2	
T3A-CW2.1	2			
编号	L	位置	数量	合计

FS-10RA	1600	T2A-CW3.1	4	52
		T2A-CW4.1	2	
		T2A-CW5.1	2	
		T2B-CW6.1	4	
		T2B-CW5.1	2	
		T2B-CW4.1	2	
		T2B-CW3.1	2	
		T2B-CW2.1	2	
		T2B-CW1.1	2	
		T2A-CW1.1	2	
		T2A-CW2.1	2	
		T1A-CW3.1	4	
		T1A-CW4.1	2	
		T1A-CW5.1	2	
		T1A-CW6.1	2	
T1B-CW6.1	2			
T1B-CW5.1	2			
T1B-CW4.1	2			
T1B-CW3.1	2			
T1B-CW2.1	2			
T1B-CW1.1	2			
T1A-CW1.1	2			
T1A-CW2.1	2			
编号	L	位置	数量	合计

 美特铝质有限公司 MIDI Aluminium Fabricator Ltd.				工程號	J858	類別		物料號	-			
				地盘	康城11期	制圖	W. E. X	2022-08-11	圖號	FS-10L		
修改	-	-	-	採用工廠	✓ 地盘	图纸名称	铝防水板加工图	復核	-	-	數量	-
日期	-	-	-	材料颜色	CHROMATE ✓	材料	1.5mm THK. 铝板	批准	-	-	單件重量	- (KG)

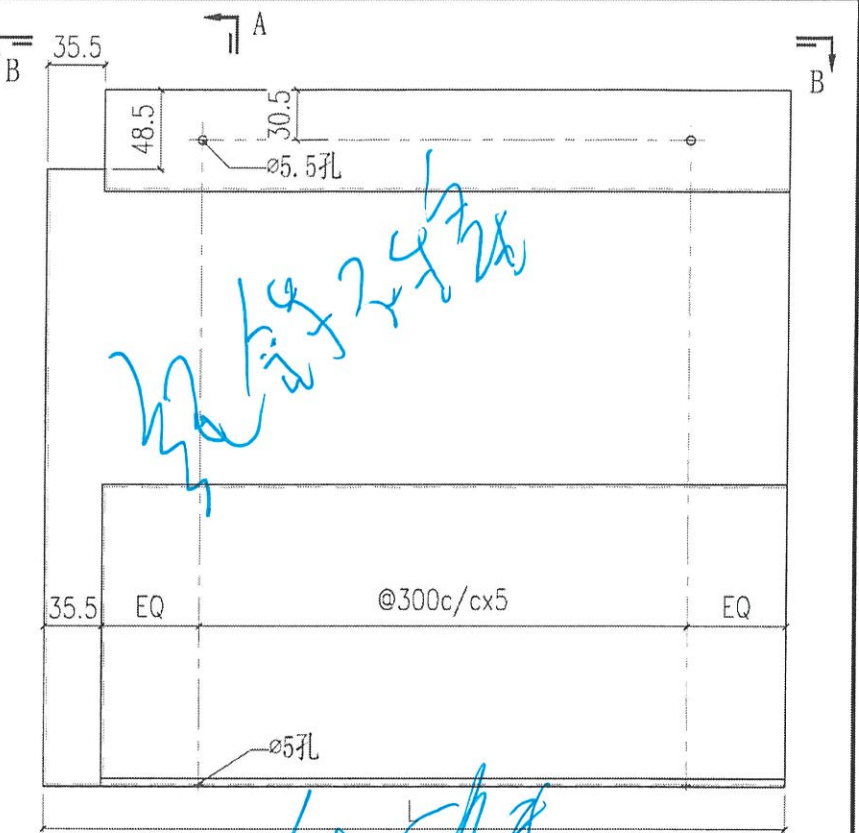
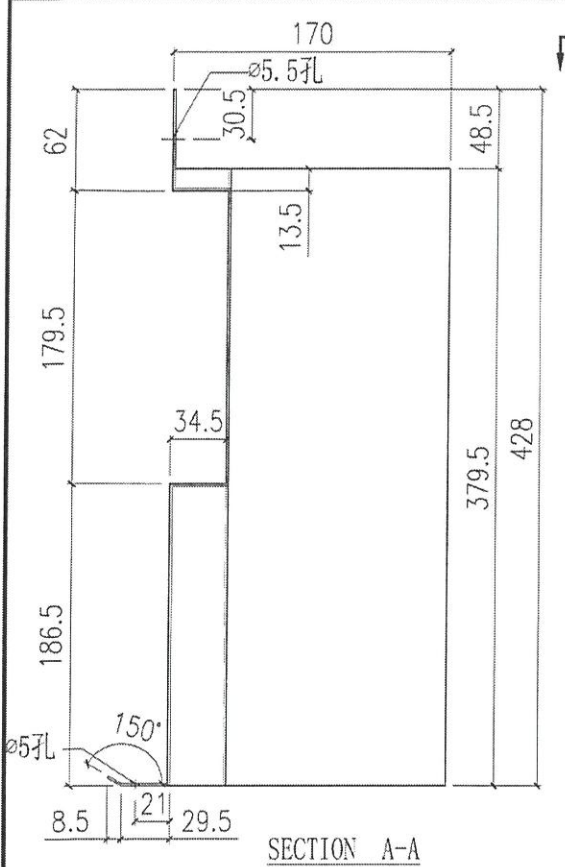

编号	L	位置	数量	合计
		T2A-CW3.1	4	
		T2A-CW4.1	2	
		T2A-CW5.1	2	
		T2B-CW6.1	4	
		T2B-CW5.1	2	
		T2B-CW4.1	2	
		T2B-CW3.1	2	
		T2B-CW2.1	2	
		T2B-CW1.1	2	
		T2A-CW1.1	2	
		T2A-CW2.1	2	
		T1A-CW3.1	4	
		T1A-CW4.1	2	
		T1A-CW5.1	2	
		T1A-CW6.1	2	
		T1B-CW6.1	2	
		T1B-CW5.1	2	
		T1B-CW4.1	2	
		T1B-CW3.1	2	
		T1B-CW2.1	2	
		T1B-CW1.1	2	
		T1A-CW1.1	2	
		T1A-CW2.1	2	
FS-10LA	1600		52	

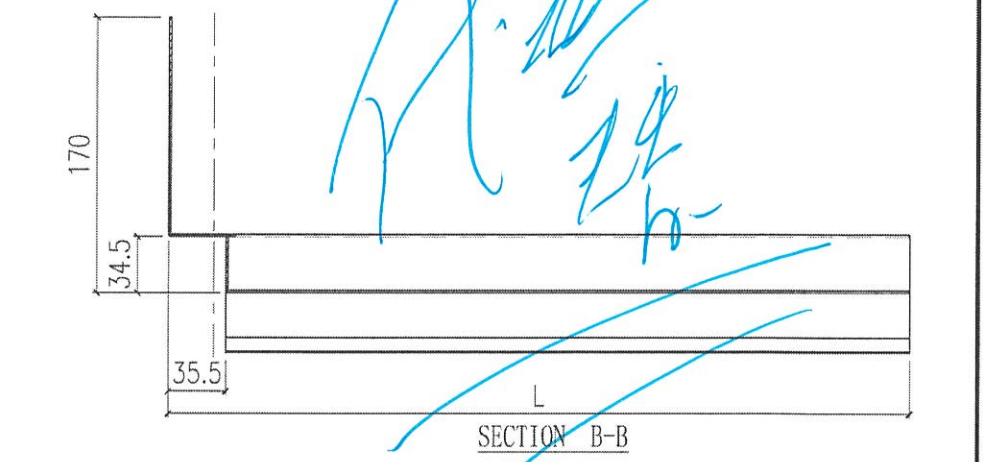

编号	L	位置	数量	合计
		T3A-CW3.1	4	
		T3A-CW4.1	2	
		T3A-CW5.1	2	
		T3B-CW6.1	4	
		T3B-CW5.1	2	
		T3B-CW4.1	2	
		T3B-CW3.1	2	
		T3B-CW2.1	2	
		T3B-CW1.1	2	
		T3A-CW1.1	2	
		T3A-CW2.1	2	
FS-10LA	1600		26	

编号	L	位置	楼层	数量	合计
		T3A-CW8 (SU)	67/F	1	
		T3B-CW10 (SU)	67/F	1	
		T3B-CW9 (SU)	67/F	1	
		T3B-CW7 (SU)	67/F	1	
		T3A-CW7 (SU)	67/F	1	
		T2A-CW10 (SU)	67/F	1	
		T2B-CW10 (SU)	67/F	1	
		T2B-CW9 (SU)	67/F	1	
		T2B-CW7 (SU)	67/F	1	
		T2A-CW6 (SU)	67/F	1	
		T1A-CW11 (SU)	62/F	1	
		T1B-CW9 (SU)	62/F	1	
		T1B-CW8 (SU)	62/F	1	
		T1B-CW6 (SU)	62/F	1	
		T1A-CW7 (SU)	62/F	1	
FS-10LA	1600			15	