

工程指示 / 要求簡箋(E.I.)

工程指示編號：EI / 5272 / 22

修改版次：A

工程編號：J - 858

工程名稱：將軍澳日出康城 LP 11

工程項目：幕牆 大貨單元件加工圖

收件人：生統

發件人：Ant Yeung

日期：29/10/2022

□要求提供 / □確認 事項：

- | | | |
|------------------------------------|-------------------------------------|-------------------------------|
| <input type="checkbox"/> 初步鋁料 B.M. | <input type="checkbox"/> 加工拆圖，然後生產 | <input type="checkbox"/> 尺寸表 |
| <input type="checkbox"/> 正式鋁料 B.M. | <input type="checkbox"/> 技術上資料 / 指示 | <input type="checkbox"/> 報價 |
| <input type="checkbox"/> 配件 B.M. | <input type="checkbox"/> 樣辦或貨品說明書 | <input type="checkbox"/> 分判合約 |

內容：

A 版：已附圖則登記表，分層統計表及位置圖 此 63 件需廠打開料單

請按加工圖生產單元件送地盆安裝。

1. 第一批為 T1 9-17/F
2. 最優先的為 T1 B- D 單位開始 拆棚平面次序見 EI5216
3. 排期按 EI4723 A
4. 附開料單 先附 T1 9-11/F，請再給 12,15,16,17 /F
5. 附 J858 康城 11 期單元件數量分層統計表(T1)(T2)(T3)
6. J858 單元件 (T1-9~11F) 加工圖數量統計表 excel to 只給生統
7. J858 單元件 (T1-9~11F) 組裝圖數量統計表.excel to 只給生統
8. 生統/ 水洪留意：早前業主視察 comment 的，需要跟進
9. 生統/ 水洪留意：試水箱所調節的，在大貨，也要相應跟進
10. 生統/ 水洪留意：轉角生窗玉用新模，需要測試開啟
11. 生統/ 水洪留意：掛勾碼暫停開避位 X86256 / X86255 (可以開料 200mm 長/ 但不開避位)：試水箱有 commnet
12. 此單包括 (T1 9-60/F, T2 9-65/F, T3 9-65/F)
13. T2 11/F 有改動 3 件，未改圖 (再跟進)

請在 2022.11.07 前完成上列要求。

附： 頁

 原合約工程包 原合約工程加 / 減賬 新工程報價
分發 拆圖 BUN 連附件

分發東莞各部門：

- | | | | |
|--|---|--|--|
| <input type="checkbox"/> 生產技術總監 <input type="checkbox"/> 連附件 | <input type="checkbox"/> 技術部 <input type="checkbox"/> 連附件 | <input type="checkbox"/> 生產部 <input type="checkbox"/> 連附件 | <input type="checkbox"/> 機械設計部 <input type="checkbox"/> 連附件 |
| <input type="checkbox"/> 採購部 <input type="checkbox"/> 連附件 | <input checked="" type="checkbox"/> 生產統籌部 <input checked="" type="checkbox"/> 連附件 | <input checked="" type="checkbox"/> 小羅&清 <input checked="" type="checkbox"/> 連附件 | |
| <input type="checkbox"/> 質檢部 <input type="checkbox"/> 連附件 | <input type="checkbox"/> 會計部 <input type="checkbox"/> 連附件 | <input type="checkbox"/> 報關組 <input type="checkbox"/> 連附件 | <input type="checkbox"/> 其他 楊榮輝 <input type="checkbox"/> 連附件 |

分發香港各部門：

- | | | | |
|---|--|---|--|
| <input type="checkbox"/> 行政部 <input type="checkbox"/> 連附件 | <input type="checkbox"/> 會計部 <input type="checkbox"/> 連附件 | <input type="checkbox"/> 統籌部 <input type="checkbox"/> 連附件 | <input checked="" type="checkbox"/> 工程部地盤科文 <input checked="" type="checkbox"/> 連附件 積哥 |
| <input type="checkbox"/> 採購部 <input type="checkbox"/> 連附件 | <input type="checkbox"/> QS 部 <input type="checkbox"/> 連附件 | <input type="checkbox"/> 維修部 <input type="checkbox"/> 連附件 | <input type="checkbox"/> 其他 _____ <input type="checkbox"/> 連附件 |

傳遞編號：

HK 1887/22

發件人簽署：

項目經理簽署：

圖則登記表
DRAWING REGISTER

工程名稱 Project Title 康城11期		接收日期 Receiving Date (適用於客戶圖則)							
單元幕牆		年							
工程編號 Project No: J858		月							
分發予 Distributed To		日							
		發出日期 Issued Date							
		年	22						
		月	10						
		日	29						
圖則編號 Drg. No.	圖則名稱 Drawing Title	修訂編號 Revision No.							
AF-033A	梗单元组装图A	-							
AF-033B	梗单元组装图B	-							
AF-034A	梗单元组装图A	-							
AF-034B	梗单元组装图B	-							
AF-035A	梗单元组装图A	-							
AF-035B	梗单元组装图B	-							
AF-036A	梗单元组装图A	-							
AF-036B	梗单元组装图B	-							
AF-037A	梗单元组装图A	-							
AF-037B	梗单元组装图B	-							
AF-038A	梗单元组装图A	-							
AF-038B	梗单元组装图B	-							
AF-039A	梗单元组装图A	-							
AF-039B	梗单元组装图B	-							
AF-040A	梗单元组装图A	-							
AF-040B	梗单元组装图B	-							
AF-041A	梗单元组装图A	-							
AF-041B	梗单元组装图B	-							
AF-042A	梗单元组装图A	-							
AF-042B	梗单元组装图B	-							
AF-043A	梗单元组装图A	-							
AF-043B	梗单元组装图B	-							
AF-044A	梗单元组装图A	-							
AF-044B	梗单元组装图B	-							
AF-045A	梗单元组装图A	-							
AF-045B	梗单元组装图B	-							
AF-046A	梗单元组装图A	-							
AF-046B	梗单元组装图B	-							
AF-047A	梗单元组装图A	-							
AF-047B	梗单元组装图B	-							
AF-048A	梗单元组装图A	-							
AF-048B	梗单元组装图B	-							
AF-049A	梗单元组装图A	-							
AF-049B	梗单元组装图B	-							
AF-050A	梗单元组装图A	-							
AF-050B	梗单元组装图B	-							
AF-051A	梗单元组装图A	-							
AF-051B	梗单元组装图B	-							
AF-052A	梗单元组装图A	-							
AF-052B	梗单元组装图B	-							

圖則登記表
DRAWING REGISTER

工程名稱 Project Title 康城11期 单元幕墙		接收日期 Receiving Date (適用於客戶圖則) 年 月 日		
工程編號 Project No: J858		發出日期 Issued Date 年 月 日		
分發予 Distributed To		22 10 29		
圖則編號 Drg. No.	圖則名稱 Drawing Title	修訂編號 Revision No.		
AF-073A	梗单元组装图A	-		
AF-073B	梗单元组装图B	-		
AF-074A	梗单元组装图A	-		
AF-074B	梗单元组装图B	-		
AF-075A	梗单元组装图A	-		
AF-075B	梗单元组装图B	-		
AF-076A	梗单元组装图A	-		
AF-076B	梗单元组装图B	-		
AF-077A	梗单元组装图A	-		
AF-077B	梗单元组装图B	-		
AF-078A	梗单元组装图A	-		
AF-078B	梗单元组装图B	-		
AF-079A	梗单元组装图A	-		
AF-079B	梗单元组装图B	-		
AF-080A	梗单元组装图A	-		
AF-080B	梗单元组装图B	-		
AF-081A	梗单元组装图A	-		
AF-081B	梗单元组装图B	-		
AF-082A	梗单元组装图A	-		
AF-082B	梗单元组装图B	-		
AF-083A	梗单元组装图A	-		
AF-083B	梗单元组装图B	-		
AF-084A	梗单元组装图A	-		
AF-084B	梗单元组装图B	-		
AF-085A	梗单元组装图A	-		
AF-085B	梗单元组装图B	-		
AF-086A	梗单元组装图A	-		
AF-086B	梗单元组装图B	-		
AF-087A	梗单元组装图A	-		
AF-087B	梗单元组装图B	-		
AF-088A	梗单元组装图A	-		
AF-088B	梗单元组装图B	-		
AF-089A	梗单元组装图A	-		
AF-089B	梗单元组装图B	-		
AF-090A	梗单元组装图A	-		
AF-090B	梗单元组装图B	-		
AF-091A	梗单元组装图A	-		
AF-091B	梗单元组装图B	-		
AF-093A	梗单元组装图A	-		
AF-093B	梗单元组装图B	-		

圖則登記表
DRAWING REGISTER

工程名稱 Project Title		接收日期 Receiving Date (適用於客戶圖則)																																																																																																																																																																																																															
康城11期		<table border="1" style="width:100%; height: 30px;"> <tr><td>年</td><td></td><td></td><td></td><td></td><td></td><td></td><td></td><td></td><td></td></tr> <tr><td>月</td><td></td><td></td><td></td><td></td><td></td><td></td><td></td><td></td><td></td></tr> <tr><td>日</td><td></td><td></td><td></td><td></td><td></td><td></td><td></td><td></td><td></td></tr> </table>		年										月										日																																																																																																																																																																																									
年																																																																																																																																																																																																																	
月																																																																																																																																																																																																																	
日																																																																																																																																																																																																																	
單元幕牆																																																																																																																																																																																																																	
工程編號 Project No: J858		發出日期 Issued Date																																																																																																																																																																																																															
分發予 Distributed To		<table border="1" style="width:100%; height: 30px;"> <tr><td>年</td><td>22</td><td></td><td></td><td></td><td></td><td></td><td></td><td></td><td></td></tr> <tr><td>月</td><td>10</td><td></td><td></td><td></td><td></td><td></td><td></td><td></td><td></td></tr> <tr><td>日</td><td>29</td><td></td><td></td><td></td><td></td><td></td><td></td><td></td><td></td></tr> </table>		年	22									月	10									日	29																																																																																																																																																																																								
年	22																																																																																																																																																																																																																
月	10																																																																																																																																																																																																																
日	29																																																																																																																																																																																																																
		修訂編號 Revision No.																																																																																																																																																																																																															
圖則編號 Drg. No.	圖則名稱 Drawing Title	<table border="1" style="width:100%; height: 100%;"> <tr><td>-</td><td></td><td></td><td></td><td></td><td></td><td></td><td></td><td></td><td></td></tr> <tr><td>-</td><td></td><td></td><td></td><td></td><td></td><td></td><td></td><td></td><td></td></tr> <tr><td>-</td><td></td><td></td><td></td><td></td><td></td><td></td><td></td><td></td><td></td></tr> <tr><td>-</td><td></td><td></td><td></td><td></td><td></td><td></td><td></td><td></td><td></td></tr> <tr><td>-</td><td></td><td></td><td></td><td></td><td></td><td></td><td></td><td></td><td></td></tr> <tr><td>-</td><td></td><td></td><td></td><td></td><td></td><td></td><td></td><td></td><td></td></tr> <tr><td>-</td><td></td><td></td><td></td><td></td><td></td><td></td><td></td><td></td><td></td></tr> <tr><td>-</td><td></td><td></td><td></td><td></td><td></td><td></td><td></td><td></td><td></td></tr> <tr><td>-</td><td></td><td></td><td></td><td></td><td></td><td></td><td></td><td></td><td></td></tr> <tr><td>-</td><td></td><td></td><td></td><td></td><td></td><td></td><td></td><td></td><td></td></tr> <tr><td>-</td><td></td><td></td><td></td><td></td><td></td><td></td><td></td><td></td><td></td></tr> <tr><td>-</td><td></td><td></td><td></td><td></td><td></td><td></td><td></td><td></td><td></td></tr> <tr><td>-</td><td></td><td></td><td></td><td></td><td></td><td></td><td></td><td></td><td></td></tr> <tr><td>-</td><td></td><td></td><td></td><td></td><td></td><td></td><td></td><td></td><td></td></tr> <tr><td>-</td><td></td><td></td><td></td><td></td><td></td><td></td><td></td><td></td><td></td></tr> <tr><td>-</td><td></td><td></td><td></td><td></td><td></td><td></td><td></td><td></td><td></td></tr> <tr><td>-</td><td></td><td></td><td></td><td></td><td></td><td></td><td></td><td></td><td></td></tr> <tr><td>-</td><td></td><td></td><td></td><td></td><td></td><td></td><td></td><td></td><td></td></tr> <tr><td>-</td><td></td><td></td><td></td><td></td><td></td><td></td><td></td><td></td><td></td></tr> <tr><td>-</td><td></td><td></td><td></td><td></td><td></td><td></td><td></td><td></td><td></td></tr> </table>								-										-										-										-										-										-										-										-										-										-										-										-										-										-										-										-										-										-										-										-									
-																																																																																																																																																																																																																	
-																																																																																																																																																																																																																	
-																																																																																																																																																																																																																	
-																																																																																																																																																																																																																	
-																																																																																																																																																																																																																	
-																																																																																																																																																																																																																	
-																																																																																																																																																																																																																	
-																																																																																																																																																																																																																	
-																																																																																																																																																																																																																	
-																																																																																																																																																																																																																	
-																																																																																																																																																																																																																	
-																																																																																																																																																																																																																	
-																																																																																																																																																																																																																	
-																																																																																																																																																																																																																	
-																																																																																																																																																																																																																	
-																																																																																																																																																																																																																	
-																																																																																																																																																																																																																	
-																																																																																																																																																																																																																	
-																																																																																																																																																																																																																	
-																																																																																																																																																																																																																	
AF-131	梗单元组装图																																																																																																																																																																																																																
AF-132	梗单元组装图																																																																																																																																																																																																																
AF-133	梗单元组装图																																																																																																																																																																																																																
AF-134	梗单元组装图																																																																																																																																																																																																																
AF-135	梗单元组装图																																																																																																																																																																																																																
AF-136	梗单元组装图																																																																																																																																																																																																																
AF-137	梗单元组装图																																																																																																																																																																																																																
AF-138	梗单元组装图																																																																																																																																																																																																																
AF-139	梗单元组装图																																																																																																																																																																																																																
AF-140	梗单元组装图																																																																																																																																																																																																																
AF-150	梗单元组装图																																																																																																																																																																																																																
AF-152	梗单元组装图																																																																																																																																																																																																																
AF-153	梗单元组装图																																																																																																																																																																																																																
AF-154	梗单元组装图																																																																																																																																																																																																																
AF-155	梗单元组装图																																																																																																																																																																																																																
AF-156	梗单元组装图																																																																																																																																																																																																																
AF-157	梗单元组装图																																																																																																																																																																																																																
AF-158	梗单元组装图																																																																																																																																																																																																																
AF-159	梗单元组装图																																																																																																																																																																																																																
AF-160	梗单元组装图																																																																																																																																																																																																																
AF-161	梗单元组装图																																																																																																																																																																																																																
AF-162	梗单元组装图																																																																																																																																																																																																																
AF-163	梗单元组装图																																																																																																																																																																																																																
AF-164	梗单元组装图																																																																																																																																																																																																																
AF-165	梗单元组装图																																																																																																																																																																																																																
AF-166	梗单元组装图																																																																																																																																																																																																																
AF-167	梗单元组装图																																																																																																																																																																																																																
AF-168	梗单元组装图																																																																																																																																																																																																																
AF-169	梗单元组装图																																																																																																																																																																																																																
AF-170	梗单元组装图																																																																																																																																																																																																																
AF-171	梗单元组装图																																																																																																																																																																																																																
AF-172	梗单元组装图																																																																																																																																																																																																																
AF-173	梗单元组装图																																																																																																																																																																																																																
AF-174	梗单元组装图																																																																																																																																																																																																																
AF-175	梗单元组装图																																																																																																																																																																																																																
AF-176	梗单元组装图																																																																																																																																																																																																																
AF-177	梗单元组装图																																																																																																																																																																																																																
AF-178	梗单元组装图																																																																																																																																																																																																																
AF-179	梗单元组装图																																																																																																																																																																																																																
AF-180	梗单元组装图																																																																																																																																																																																																																

圖則登記表
DRAWING REGISTER

工程名稱 Project Title 康城11期		接收日期 Receiving Date (適用於客戶圖則)							
		年							
單元幕墙		月							
工程編號 Project No: J858		日							
分發予 Distributed To		發出日期 Issued Date							
		年	22						
		月	10						
		日	29						
圖則編號 Drg. No.	圖則名稱 Drawing Title	修訂編號 Revision No.							
AS-15B	生单元组装图B	-							
AS-15C	生单元组装图C	-							
AS-16A	生单元组装图A	-							
AS-16B	生单元组装图B	-							
AS-17A	生单元组装图A	-							
AS-17B	生单元组装图B	-							
AS-18A	生单元组装图A	-							
AS-18B	生单元组装图B	-							
AS-19A	生单元组装图A	-							
AS-19B	生单元组装图B	-							
AS-19C	生单元组装图C	-							
AS-20A	生单元组装图A	-							
AS-20B	生单元组装图B	-							
AS-21A	生单元组装图A	-							
AS-21B	生单元组装图B	-							
AS-22A	生单元组装图A	-							
AS-22B	生单元组装图B	-							
AS-23A	生单元组装图A	-							
AS-23B	生单元组装图B	-							
AS-24A	生单元组装图A	-							
AS-24B	生单元组装图B	-							
AS-25A	生单元组装图A	-							
AS-25B	生单元组装图B	-							
AS-26A	生单元组装图A	-							
AS-26B	生单元组装图B	-							
AS-26C	生单元组装图C	-							
AS-27A	生单元组装图A	-							
AS-27B	生单元组装图B	-							
AS-28A	生单元组装图A	-							
AS-28B	生单元组装图B	-							
AM-01A	中企单元组装图A	-							
AM-01B	中企单元组装图B	-							
AM-01C	中企单元组装图C	-							
AM-02A	中企单元组装图A	-							
AM-02B	中企单元组装图B	-							
AM-03A	中企单元组装图A	-							
AM-03B	中企单元组装图B	-							
AM-03C	中企单元组装图C	-							
AM-03D	中企单元组装图D	-							

圖則登記表
DRAWING REGISTER

工程名稱 Project Title 康城11期		接收日期 Receiving Date (適用於客戶圖則)							
		年							
單元幕墙		月							
工程編號 Project No: J858		日							
分發予 Distributed To		發出日期 Issued Date							
		年	22						
		月	10						
		日	29						
圖則編號 Drg. No.	圖則名稱 Drawing Title	修訂編號 Revision No.							
AM-04A	中企单元组装图A	-							
AM-04B	中企单元组装图B	-							
AM-05A	中企单元组装图A	-							
AM-05B	中企单元组装图B	-							
AM-05C	中企单元组装图C	-							
AM-06A	中企单元组装图A	-							
AM-06B	中企单元组装图B	-							
AM-07A	中企单元组装图A	-							
AM-07B	中企单元组装图B	-							
AM-08A	中企单元组装图A	-							
AM-08B	中企单元组装图B	-							
AM-09A	中企单元组装图A	-							
AM-09B	中企单元组装图B	-							
AM-10A	中企单元组装图A	-							
AM-10B	中企单元组装图B	-							
AM-10C	中企单元组装图C	-							
AM-11A	中企单元组装图A	-							
AM-11B	中企单元组装图B	-							
AM-11C	中企单元组装图C	-							
AM-12A	中企单元组装图A	-							
AM-12B	中企单元组装图B	-							
AM-13A	中企单元组装图A	-							
AM-13B	中企单元组装图B	-							
AM-14A	中企单元组装图A	-							
AM-14B	中企单元组装图B	-							
AM-15A	中企单元组装图A	-							
AM-15B	中企单元组装图B	-							
AM-16A	中企单元组装图A	-							
AM-16B	中企单元组装图B	-							
AM-17A	中企单元组装图A	-							
AM-17B	中企单元组装图B	-							
AM-18A	中企单元组装图A	-							
AM-18B	中企单元组装图B	-							
AM-19A	中企单元组装图A	-							
AM-19B	中企单元组装图B	-							

圖則登記表
DRAWING REGISTER

工程名稱 Project Title 康城11期 单元幕墙		接收日期 Receiving Date (適用於客戶圖則) 年 月 日			
工程編號 Project No: J858		發出日期 Issued Date 年 月 日			
分發予 Distributed To		22 10 29			
圖則編號 Drg. No.	圖則名稱 Drawing Title	修訂編號 Revision No.			
AM-40A	中企单元组装图A	-			
AM-40B	中企单元组装图B	-			
AM-41A	中企单元组装图A	-			
AM-41B	中企单元组装图B	-			
AM-42A	中企单元组装图A	-			
AM-42B	中企单元组装图B	-			
AM-43A	中企单元组装图A	-			
AM-43B	中企单元组装图B	-			
AM-44A	中企单元组装图A	-			
AM-44B	中企单元组装图B	-			
AM-45A	中企单元组装图A	-			
AM-45B	中企单元组装图B	-			
AM-46A	中企单元组装图A	-			
AM-46B	中企单元组装图B	-			
AM-47A	中企单元组装图A	-			
AM-47B	中企单元组装图B	-			
AM-48A	中企单元组装图A	-			
AM-48B	中企单元组装图B	-			
AM-49A	中企单元组装图A	-			
AM-49B	中企单元组装图B	-			
AM-50A	中企单元组装图A	-			
AM-50B	中企单元组装图B	-			
AM-51A	中企单元组装图A	-			
AM-51B	中企单元组装图B	-			
AM-52A	中企单元组装图A	-			
AM-52B	中企单元组装图B	-			
AM-53A	中企单元组装图A	-			
AM-53B	中企单元组装图B	-			
AM-54A	中企单元组装图A	-			
AM-54B	中企单元组装图B	-			
AM-55A	中企单元组装图A	-			
AM-55B	中企单元组装图B	-			
AM-56A	中企单元组装图A	-			
AM-56B	中企单元组装图B	-			
AM-57A	中企单元组装图A	-			
AM-57B	中企单元组装图B	-			

圖則登記表
DRAWING REGISTER

工程名稱 Project Title		接收日期 Receiving Date (適用於客戶圖則)		
康城11期		年	月	
單元幕墙		日	日	
工程編號 Project No: J858				
分發予 Distributed To		發出日期 Issued Date		
		年	月	
		日	日	
		22	29	
		10		
		29		
圖則編號 Drg. No.	圖則名稱 Drawing Title	修訂編號 Revision No.		
J858-CW-SH01L	窗玉組裝圖	-		
J858-CW-SH01R	窗玉組裝圖	-		
J858-CW-SH02	窗玉組裝圖	-		
J858-CW-SH03L	窗玉組裝圖	-		
J858-CW-SH03R	窗玉組裝圖	-		
J858-CW-SH04L	窗玉組裝圖	-		
J858-CW-SH04R	窗玉組裝圖	-		
J858-CW-SH05	窗玉組裝圖	-		
J858-CW-SH06	窗玉組裝圖	-		
J858-CW-SH07	窗玉組裝圖	-		
J858-CW-SH08L	窗玉組裝圖	-		
J858-CW-SH08R	窗玉組裝圖	-		
X86299-S01L	窗玉加工圖	-		
X86299-S01R	窗玉加工圖	-		
X86299-S02L	窗玉加工圖	-		
X86299-S02R	窗玉加工圖	-		
X86299-S03L	窗玉加工圖	-		
X86299-S03R	窗玉加工圖	-		
X86299-S04L	窗玉加工圖	-		
X86299-S04R	窗玉加工圖	-		
X86299-S07L	窗玉加工圖	-		
X86299-S07R	窗玉加工圖	-		
X86299-S08L	窗玉加工圖	-		
X86299-S08R	窗玉加工圖	-		
X86284-S01	窗玉加工圖	-		
X86284-S02L	窗玉加工圖	-		
X86284-S02R	窗玉加工圖	-		
X86285-S01	窗玉加工圖	-		
X86351-S01	窗玉加工圖	-		
X86283-S01	窗玉加工圖	-		
H122785-S01	窗玉加工圖	-		
H122785-S02	窗玉加工圖	-		
H122785-S03L	窗玉加工圖	-		
H122785-S03R	窗玉加工圖	-		
X86318-S01	窗玉加工圖	-		
X86318-S03L	窗玉加工圖	-		
X86318-S03R	窗玉加工圖	-		
L011-S01	窗玉加工圖	-		
J858-SS-S01	窗玉加工圖	-		
J858-AP-S01	窗玉加工圖	-		
L065-S01	窗玉加工圖	-		

圖則登記表
DRAWING REGISTER

工程名稱 Project Title 康城11期 单元幕墙 工程編號 Project No: J858 分發予 Distributed To 		年 月 日	接收日期 Receiving Date (適用於客戶圖則) 發出日期 Issued Date 22 10 29
圖則編號 Drg. No.	圖則名稱 Drawing Title	修訂編號 Revision No.	
X86272-01	单元企料加工图	-	
X86272-04	单元企料加工图	-	
X86272-05	单元企料加工图	-	
X86272-06	单元企料加工图	-	
X86272-07	单元企料加工图	-	
X86272-08	单元企料加工图	-	
X86272-09	单元企料加工图	-	
X86272-10	单元企料加工图	-	
X86272-11	单元企料加工图	-	
X86273-01	单元企料加工图	-	
X86273-02	单元企料加工图	-	
X86273-06	单元企料加工图	-	
X86273-07	单元企料加工图	-	
X86273-08	单元企料加工图	-	
X86273-09	单元企料加工图	-	
X86273-10	单元企料加工图	-	
X86273-11	单元企料加工图	-	
X86273-12	单元企料加工图	-	
X86273-13	单元企料加工图	-	
X86273-14	单元企料加工图	-	
X86273-15	单元企料加工图	-	
X86273-16	单元企料加工图	-	
X86274-01	单元企料加工图	-	
X86274-02	单元企料加工图	-	
X86274-05	单元企料加工图	-	
X86274-06	单元企料加工图	-	
X86274-07	单元企料加工图	-	
X86274-08	单元企料加工图	-	
X86274-09	单元企料加工图	-	
X86274-10	单元企料加工图	-	
X86288-01	单元企料加工图	-	
X86288-02	单元企料加工图	-	
X86288-07	单元企料加工图	-	
X86288-08	单元企料加工图	-	
X86288-09	单元企料加工图	-	
X86288-10	单元企料加工图	-	
X86288-11	单元企料加工图	-	
X86288-12	单元企料加工图	-	
X86277-03L	单元企料加工图	-	
X86277-03R	单元企料加工图	-	

圖則登記表
DRAWING REGISTER

工程名稱 Project Title 康城11期		接收日期 Receiving Date (適用於客戶圖則)							
		年							
單元幕墙		月							
工程編號 Project No: J858		日							
分發予 Distributed To		發出日期 Issued Date							
		年	22						
		月	10						
		日	29						
圖則編號 Drg. No.	圖則名稱 Drawing Title	修訂編號 Revision No.							
X86277-04L	單元企料加工图	-							
X86277-04R	單元企料加工图	-							
X86277-05L	單元企料加工图	-							
X86277-05R	單元企料加工图	-							
X86277-06L	單元企料加工图	-							
X86277-06R	單元企料加工图	-							
X86277-08L	單元企料加工图	-							
X86277-08R	單元企料加工图	-							
X86277-09L	單元企料加工图	-							
X86277-09R	單元企料加工图	-							
X86277-10L	單元企料加工图	-							
X86277-10R	單元企料加工图	-							
X86277-11L	單元企料加工图	-							
X86277-11R	單元企料加工图	-							
X86277-12	單元企料加工图	-							
X86277-13	單元企料加工图	-							
X86277-14L	單元企料加工图	-							
X86277-14R	單元企料加工图	-							
X86277-15L	單元企料加工图	-							
X86277-15R	單元企料加工图	-							
X86277-16L	單元企料加工图	-							
X86277-16R	單元企料加工图	-							
X86278-01	單元企料加工图	-							
X86278-02	單元企料加工图	-							
X86278-04L	單元企料加工图	-							
X86278-04R	單元企料加工图	-							
X86278-05L	單元企料加工图	-							
X86278-05R	單元企料加工图	-							
X86278-06L	單元企料加工图	-							
X86278-06R	單元企料加工图	-							
X86278-07L	單元企料加工图	-							
X86278-07R	單元企料加工图	-							
X86278-08L	單元企料加工图	-							
X86278-08R	單元企料加工图	-							
X86278-09L	單元企料加工图	-							
X86278-09R	單元企料加工图	-							
X86278-10R	單元企料加工图	-							
X86278-11L	單元企料加工图	-							
X86278-11R	單元企料加工图	-							
X86278-12L	單元企料加工图	-							

圖則登記表
DRAWING REGISTER

工程名稱 Project Title 康城11期		接收日期 Receiving Date (適用於客戶圖則)							
		年							
單元幕墙		月							
工程編號 Project No: J858		日							
分發予 Distributed To		發出日期 Issued Date							
		年	22						
		月	10						
		日	29						
圖則編號 Drg. No.	圖則名稱 Drawing Title	修訂編號 Revision No.							
X86278-12R	單元企料加工图	-							
X86278-13L	單元企料加工图	-							
X86278-13R	單元企料加工图	-							
X86278-15L	單元企料加工图	-							
X86278-15R	單元企料加工图	-							
X86278-16L	單元企料加工图	-							
X86278-16R	單元企料加工图	-							
X86278-17L	單元企料加工图	-							
X86278-17R	單元企料加工图	-							
X86278-18L	單元企料加工图	-							
X86278-18R	單元企料加工图	-							
X86278-19L	單元企料加工图	-							
X86278-19R	單元企料加工图	-							
X86278-24L	單元企料加工图	-							
X86278-24R	單元企料加工图	-							
X86278-25L	單元企料加工图	-							
X86278-26L	單元企料加工图	-							
X86278-27L	單元企料加工图	-							
X86278-27R	單元企料加工图	-							
X86275-01	單元企料加工图	-							
X86275-04	單元企料加工图	-							
X86275-05	單元企料加工图	-							
X86275-06	單元企料加工图	-							
X86275-07	單元企料加工图	-							
X86275-08	單元企料加工图	-							
X86275-09	單元企料加工图	-							
X86276-01	單元企料加工图	-							
X86276-03	單元企料加工图	-							
X86276-04	單元企料加工图	-							
X86295-01	單元企料加工图	-							
X86295-02	單元企料加工图	-							
X86296-02	單元企料加工图	-							
X86296-05	單元企料加工图	-							
X86296-06	單元企料加工图	-							
X86296-07	單元企料加工图	-							
X86296-08	單元企料加工图	-							
X86294-01	單元企料加工图	-							
X86294-03	單元企料加工图	-							
X86294-05L	單元企料加工图	-							
X86294-05R	單元企料加工图	-							

圖則登記表
DRAWING REGISTER

工程名稱 Project Title 康城11期		接收日期 Receiving Date (適用於客戶圖則)							
		年							
單元幕牆		月							
工程編號 Project No: J858		日							
分發予 Distributed To		發出日期 Issued Date							
		年	22						
		月	10						
		日	29						
圖則編號 Drg. No.	圖則名稱 Drawing Title	修訂編號 Revision No.							
X86308-16	單元橫料加工圖	-							
X86308-17	單元橫料加工圖	-							
X86308-18	單元橫料加工圖	-							
X86308-19	單元橫料加工圖	-							
X86308-20	單元橫料加工圖	-							
X86308-21	單元橫料加工圖	-							
X86308-22	單元橫料加工圖	-							
X86308-23	單元橫料加工圖	-							
X86309-01L	單元橫料加工圖	-							
X86309-01R	單元橫料加工圖	-							
X86309-02L	單元橫料加工圖	-							
X86309-02R	單元橫料加工圖	-							
X86309-03L	單元橫料加工圖	-							
X86309-03R	單元橫料加工圖	-							
X86309-05L	單元橫料加工圖	-							
X86309-05R	單元橫料加工圖	-							
X86309-06L	單元橫料加工圖	-							
X86309-06R	單元橫料加工圖	-							
X86309-07L	單元橫料加工圖	-							
X86309-07R	單元橫料加工圖	-							
X86309-09	單元橫料加工圖	-							
X86309-10	單元橫料加工圖	-							
L065-01	單元輔料加工圖	-							
N516-01	單元輔料加工圖	-							
N00813-01	單元輔料加工圖	-							
N00813-02	單元輔料加工圖	-							
X86316-01	單元輔料加工圖	-							
J858-AA03L	單元輔料加工圖	-							
J858-AA03R	單元輔料加工圖	-							
J858-AA04L	單元輔料加工圖	-							
J858-AA04R	單元輔料加工圖	-							
J858-AP02	單元輔料加工圖	-							
J858-AP03	單元輔料加工圖	-							
J858-AP04	單元輔料加工圖	-							
J858-AP05	單元輔料加工圖	-							
J858-AP06	單元輔料加工圖	-							
J858-AP07	單元輔料加工圖	-							
J858-AP08	單元輔料加工圖	-							
J858-AP09	單元輔料加工圖	-							
J858-AP10	單元輔料加工圖	-							

圖則登記表
DRAWING REGISTER

工程名稱 Project Title 康城11期		接收日期 Receiving Date (適用於客戶圖則)		
單元幕牆		年		
工程編號 Project No: J858		月		
分發予 Distributed To		日		
		發出日期 Issued Date		
		年		
		月		
		日		
圖則編號 Drg. No.	圖則名稱 Drawing Title	修訂編號 Revision No.		
X86314-03L	單元輔料加工圖	-		
X86314-03R	單元輔料加工圖	-		
X86314-04L	單元輔料加工圖	-		
X86314-04R	單元輔料加工圖	-		
X86314-05L	單元輔料加工圖	-		
X86314-05R	單元輔料加工圖	-		
X86305-01	單元輔料加工圖	-		
X86305-02	單元輔料加工圖	-		
X86305-03	單元輔料加工圖	-		
X86305-04	單元輔料加工圖	-		
X86305-05	單元輔料加工圖	-		
X86304-01	單元輔料加工圖	-		
X86304-02	單元輔料加工圖	-		
X86304-03	單元輔料加工圖	-		
X86304-04	單元輔料加工圖	-		
X86303-01	單元輔料加工圖	-		
X86303-02	單元輔料加工圖	-		
X86303-03	單元輔料加工圖	-		
X86303-04	單元輔料加工圖	-		
X86303-05	單元輔料加工圖	-		
X86306-01	單元輔料加工圖	-		
X86306-02	單元輔料加工圖	-		
X86306-03	單元輔料加工圖	-		
X86306-04	單元輔料加工圖	-		
X86306-05	單元輔料加工圖	-		
X86306-06	單元輔料加工圖	-		
N541-01	單元輔料加工圖	-		
X86282-01	單元輔料加工圖	-		
X86286-01L	單元輔料加工圖	-		
X86286-01R	單元輔料加工圖	-		
X86283-01	單元輔料加工圖	-		
X86283-02	單元輔料加工圖	-		
X86283-03	單元輔料加工圖	-		
X86283-04	單元輔料加工圖	-		
X86300-01	單元輔料加工圖	-		
X86301-01	單元輔料加工圖	-		
X86307-01	單元輔料加工圖	-		
X86307-02	單元輔料加工圖	-		
X86307-03	單元輔料加工圖	-		

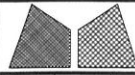

美特鋁質有限公司
MIDI Aluminium Fabricator Ltd.

工程號	J858	類別		物料號	-	
地盘	康城11期	制圖	Z. S. P	2022-08-06	圖號	AZe-1631H2
修改	1	採用工廠	地盤	✓	圖紙名稱	单元组装图
日期	29/10	材料颜色	-		復核	-
					批准	-
					數量	-
					單件重量	- (KG)

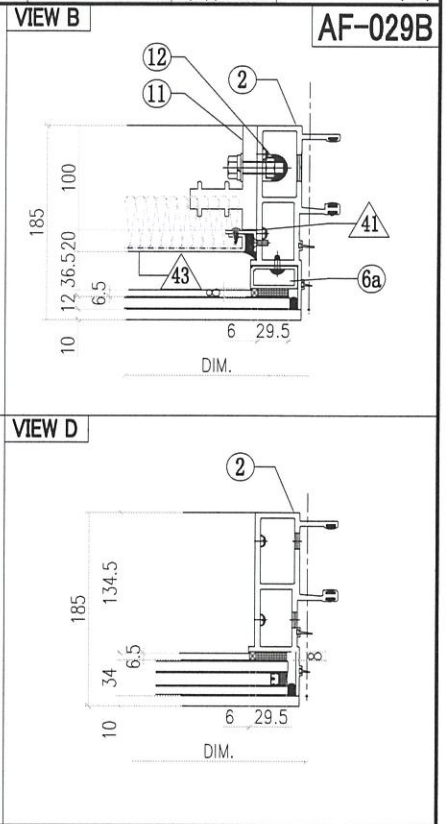
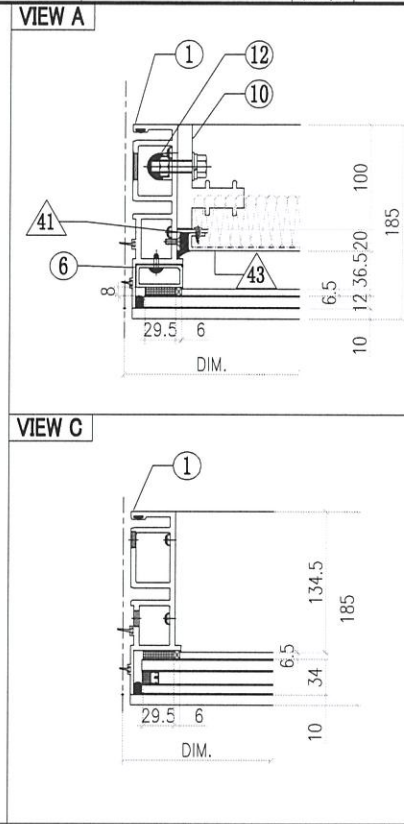
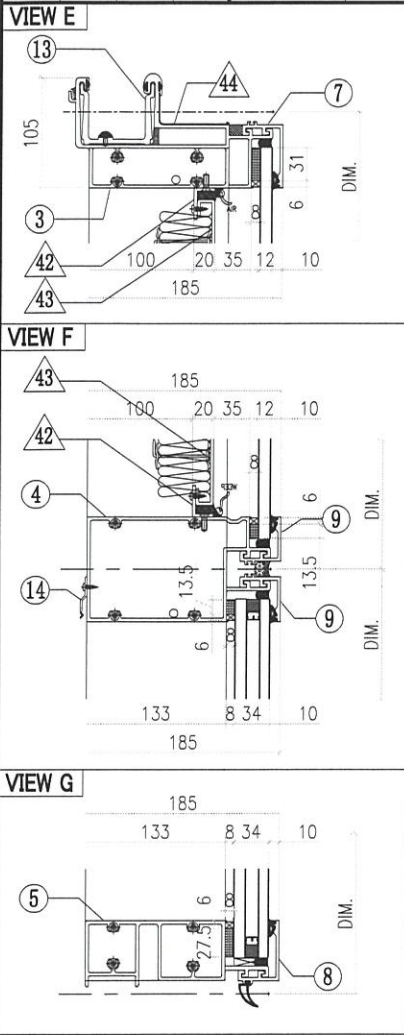

AF-029B

INSTALL UNIT NO.	QTY.	FLOOR
T1A-CW6-0901	1	9/F
T1A-CW6-1001	1	10/F
T1A-CW6-1201	1	12/F
T1A-CW6-1501	1	15/F
T1A-CW6-1701	1	17/F
T1A-CW6-1801	1	18/F
T1A-CW6-1901	1	19/F
T1A-CW6-2001	1	20/F
T1A-CW6-2101	1	21/F
T1A-CW6-2301	1	23/F
T1A-CW6-2501	1	25/F
T1A-CW6-2601	1	26/F
T1A-CW6-2701	1	27/F
T1A-CW6-2801	1	28/F
T1A-CW6-3001	1	30/F
T1A-CW6-3101	1	31/F
T1A-CW6-3201	1	32/F
T1A-CW6-3301	1	33/F
T1A-CW6-3501	1	35/F
T1A-CW6-3701	1	37/F
T1A-CW6-3801	1	38/F

T1A-CW6-3901	1	39/F
T1A-CW6-4101	1	41/F
T1A-CW6-4301	1	43/F
T1A-CW6-4501	1	45/F
T1A-CW6-4601	1	46/F
T1A-CW6-4701	1	47/F
T1A-CW6-4801	1	48/F
T1A-CW6-5001	1	50/F
T1A-CW6-5101	1	51/F
T1A-CW6-5201	1	52/F
T1A-CW6-5301	1	53/F
T1A-CW6-5501	1	55/F
T1A-CW6-5701	1	57/F
T1A-CW6-5801	1	58/F
T1A-CW6-5901	1	59/F
T1A-CW6-6001	1	60/F
TOTAL	37	

OTHERS (ALUM. & G.M.S. PARTS)			
ITEM	FAB. DWG NO.	LENGTH (mm)	QTY
41	N00813-01A	720.5	2
	30x20X3mm ALUM. ANGLE		
42	N00813-01T	1529	2
	30x20X3mm ALUM. ANGLE		
43	J858-AP09-11		1
	1509 x760.5(BACK PANEL)		
44	J858-AP16	100	1
	1mm THK. ALUM. FLASHING		

ALUM. EXTRUSION			
ITEM	FAB. DWG NO.	LENGTH (mm)	QTY
1	X86273-01	3267.5	1
2	X86272-01	3267.5	1
3	X86279-15E	1616	1
4	X86302-01G	1610	1
5	X86280-01G	1610	1
6	X86305-01LA	828.5	1
6a	X86305-01RA	828.5	1
7	X86301-01-14	1616	1
8	X86300-01-14	1616	1
9	X86283-01-15	1616	2
10	X86255-01L	200	1
11	X86255-01R	200	1
12	X86258-01	200	2
13	X86303-01	300	1
14	X86317-01	50	6

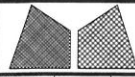

美特鋁質有限公司

MIDI Aluminium Fabricator Ltd.

工程號

J858

類別

物料號

-

地盘

康城11期

制圖

Z. S. P

2022-06-28

圖號

ARm-700H1-b2

修改 1

採用工廠

地盘 ✓

图纸名称

单元组装图

復核

-

-

數量

-

日期 29/10

材料颜色

-

材料

-

批准

-

-

單件重量

(KG)

INSTALL UNIT NO.	QTY.	FLOOR	T1B-CW4-4203	1	42/F	T3A-CW2-1804	1	18/F
T1A-CW2-0904	1	9/F	T1B-CW4-4503	1	45/F	T3A-CW2-1904	1	19/F
T1A-CW2-1004	1	10/F	T1B-CW4-4603	1	46/F	T3A-CW2-2004	1	20/F
T1A-CW2-0404	1	12/F	T1B-CW4-4703	1	47/F	T3A-CW2-2204	1	22/F
T1A-CW2-1504	1	15/F	T1B-CW4-4903	1	49/F	T3A-CW2-2304	1	23/F
T1A-CW2-1604	1	16/F	T1B-CW4-5003	1	50/F	T3A-CW2-2504	1	25/F
T1A-CW2-1804	1	18/F	T1B-CW4-5103	1	51/F	T3A-CW2-2704	1	27/F
T1A-CW2-1904	1	19/F	T1B-CW4-5303	1	53/F	T3A-CW2-2804	1	28/F
T1A-CW2-2004	1	20/F	T1B-CW4-5503	1	55/F	T3A-CW2-2904	1	29/F
T1A-CW2-2204	1	22/F	T1B-CW4-5603	1	56/F	T3A-CW2-3104	1	31/F
T1A-CW2-2304	1	23/F	T1B-CW4-5803	1	58/F	T3A-CW2-3204	1	32/F
T1A-CW2-2504	1	25/F	T1B-CW4-5903	1	59/F	T3A-CW2-3304	1	33/F
T1A-CW2-2704	1	27/F	T1B-CW4-6003	1	60/F	T3A-CW2-3604	1	36/F
T1A-CW2-2804	1	28/F				T3A-CW2-3704	1	37/F
T1A-CW2-2904	1	29/F	T2A-CW2-0904	1	9/F	T3A-CW2-3804	1	38/F
T1A-CW2-3104	1	31/F	T2A-CW2-1004	1	10/F	T3A-CW2-4104	1	41/F
T1A-CW2-3204	1	32/F	T2A-CW2-0404	1	12/F	T3A-CW2-4204	1	42/F
T1A-CW2-3304	1	33/F	T2A-CW2-1504	1	15/F	T3A-CW2-4504	1	45/F
T1A-CW2-3604	1	36/F	T2A-CW2-1604	1	16/F	T3A-CW2-4604	1	46/F
T1A-CW2-3704	1	37/F	T2A-CW2-1804	1	18/F	T3A-CW2-4704	1	47/F
T1A-CW2-3804	1	38/F	T2A-CW2-1904	1	19/F	T3A-CW2-4904	1	49/F
T1A-CW2-4104	1	41/F	T2A-CW2-2004	1	20/F	T3A-CW2-5004	1	50/F
T1A-CW2-4204	1	42/F	T2A-CW2-2204	1	22/F	T3A-CW2-5104	1	51/F
T1A-CW2-4504	1	45/F	T2A-CW2-2304	1	23/F	T3A-CW2-5304	1	53/F
T1A-CW2-4604	1	46/F	T2A-CW2-2504	1	25/F	T3A-CW2-5504	1	55/F
T1A-CW2-4704	1	47/F	T2A-CW2-2704	1	27/F	T3A-CW2-5604	1	56/F
T1A-CW2-4904	1	49/F	T2A-CW2-2804	1	28/F	T3A-CW2-5804	1	58/F
T1A-CW2-5004	1	50/F	T2A-CW2-2904	1	29/F	T3A-CW2-5904	1	59/F
T1A-CW2-5104	1	51/F	T2A-CW2-3104	1	31/F	T3A-CW2-6004	1	60/F
T1A-CW2-5304	1	53/F	T2A-CW2-3204	1	32/F	T3A-CW2-6204	1	62/F
T1A-CW2-5504	1	55/F	T2A-CW2-3304	1	33/F	T3A-CW2-6304	1	63/F
T1A-CW2-5604	1	56/F	T2A-CW2-3604	1	36/F	T3A-CW2-6504	1	65/F
T1A-CW2-5804	1	58/F	T2A-CW2-3704	1	37/F			
T1A-CW2-5904	1	59/F	T2A-CW2-3804	1	38/F	T3B-CW4-0903	1	9/F
T1A-CW2-6004	1	60/F	T2A-CW2-4104	1	41/F	T3B-CW4-1003	1	10/F
			T2A-CW2-4204	1	42/F	T3B-CW4-0303	1	12/F
T1B-CW4-0903	1	9/F	T2A-CW2-4504	1	45/F	T3B-CW4-1503	1	15/F
T1B-CW4-1003	1	10/F	T2A-CW2-4604	1	46/F	T3B-CW4-1603	1	16/F
T1B-CW4-1203	1	12/F	T2A-CW2-4704	1	47/F	T3B-CW4-1803	1	18/F
T1B-CW4-1503	1	15/F	T2A-CW2-4904	1	49/F	T3B-CW4-1903	1	19/F
T1B-CW4-1603	1	16/F	T2A-CW2-5004	1	50/F	T3B-CW4-2003	1	20/F
T1B-CW4-1803	1	18/F	T2A-CW2-5104	1	51/F	T3B-CW4-2203	1	22/F
T1B-CW4-1903	1	19/F	T2A-CW2-5304	1	53/F	T3B-CW4-2303	1	23/F
T1B-CW4-2003	1	20/F	T2A-CW2-5504	1	55/F	T3B-CW4-2503	1	25/F
T1B-CW4-2203	1	22/F	T2A-CW2-5604	1	56/F	T3B-CW4-2703	1	27/F
T1B-CW4-2303	1	23/F	T2A-CW2-5804	1	58/F	T3B-CW4-2803	1	28/F
T1B-CW4-2503	1	25/F	T2A-CW2-5904	1	59/F	T3B-CW4-2903	1	29/F
T1B-CW4-2703	1	27/F	T2A-CW2-6004	1	60/F	T3B-CW4-3103	1	31/F
T1B-CW4-2803	1	28/F	T2A-CW2-6204	1	62/F	T3B-CW4-3203	1	32/F
T1B-CW4-2903	1	29/F	T2A-CW2-6304	1	63/F	T3B-CW4-3303	1	33/F
T1B-CW4-3103	1	31/F	T2A-CW2-6504	1	65/F	T3B-CW4-3603	1	36/F
T1B-CW4-3203	1	32/F				T3B-CW4-3703	1	37/F
T1B-CW4-3303	1	33/F	T3A-CW2-0904	1	9/F	T3B-CW4-3803	1	38/F
T1B-CW4-3603	1	36/F	T3A-CW2-1004	1	10/F	T3B-CW4-4103	1	41/F
T1B-CW4-3703	1	37/F	T3A-CW2-0404	1	12/F	T3B-CW4-4203	1	42/F
T1B-CW4-3803	1	38/F	T3A-CW2-1504	1	15/F	T3B-CW4-4503	1	45/F
T1B-CW4-4103	1	41/F	T3A-CW2-1604	1	16/F	T3B-CW4-4603	1	46/F

AS-01C

T3B-CW4-4703	1	47/F
T3B-CW4-4903	1	49/F
T3B-CW4-5003	1	50/F
T3B-CW4-5103	1	51/F
T3B-CW4-5303	1	53/F
T3B-CW4-5503	1	55/F
T3B-CW4-5603	1	56/F
T3B-CW4-5803	1	58/F
T3B-CW4-5903	1	59/F
T3B-CW4-6003	1	60/F
T3B-CW4-6203	1	62/F
T3B-CW4-6303	1	63/F
T3B-CW4-6503	1	65/F
TOTAL	179	

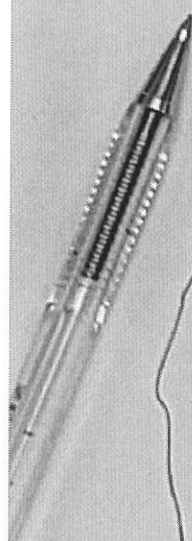

	T1B-CW5	T1B-CW6	T1A-CW5	T1A-CW4
19F	T1B-CW5-1101	T1B-CW6-1101	T1A-CW5-1101	T1A-CW4-1101
18F	T1B-CW5-1102	T1B-CW6-1102	T1A-CW5-1102	T1A-CW4-1102
17F	T1B-CW5-1103	T1B-CW6-1103	T1A-CW5-1103	T1A-CW4-1103
16F	T1B-CW5-1104	T1B-CW6-1104	T1A-CW5-1104	T1A-CW4-1104
15F	T1B-CW5-1105	T1B-CW6-1105	T1A-CW5-1105	T1A-CW4-1105
14F	T1B-CW5-1106	T1B-CW6-1106	T1A-CW5-1106	T1A-CW4-1106
13F	T1B-CW5-1107	T1B-CW6-1107	T1A-CW5-1107	T1A-CW4-1107
12F	T1B-CW5-1108	T1B-CW6-1108	T1A-CW5-1108	T1A-CW4-1108
11F	T1B-CW5-1109	T1B-CW6-1109	T1A-CW5-1109	T1A-CW4-1109
10F	T1B-CW5-1110	T1B-CW6-1110	T1A-CW5-1110	T1A-CW4-1110
9F	T1B-CW5-1111	T1B-CW6-1111	T1A-CW5-1111	T1A-CW4-1111
	T1B-CW5-1112	T1B-CW6-1112	T1A-CW5-1112	T1A-CW4-1112
	T1B-CW5-1113	T1B-CW6-1113	T1A-CW5-1113	T1A-CW4-1113
	T1B-CW5-1114	T1B-CW6-1114	T1A-CW5-1114	T1A-CW4-1114
	T1B-CW5-1115	T1B-CW6-1115	T1A-CW5-1115	T1A-CW4-1115
	T1B-CW5-1116	T1B-CW6-1116	T1A-CW5-1116	T1A-CW4-1116
	T1B-CW5-1117	T1B-CW6-1117	T1A-CW5-1117	T1A-CW4-1117
	T1B-CW5-1118	T1B-CW6-1118	T1A-CW5-1118	T1A-CW4-1118
	T1B-CW5-1119	T1B-CW6-1119	T1A-CW5-1119	T1A-CW4-1119
	T1B-CW5-1120	T1B-CW6-1120	T1A-CW5-1120	T1A-CW4-1120
	T1B-CW5-1121	T1B-CW6-1121	T1A-CW5-1121	T1A-CW4-1121
	T1B-CW5-1122	T1B-CW6-1122	T1A-CW5-1122	T1A-CW4-1122
	T1B-CW5-1123	T1B-CW6-1123	T1A-CW5-1123	T1A-CW4-1123
	T1B-CW5-1124	T1B-CW6-1124	T1A-CW5-1124	T1A-CW4-1124
	T1B-CW5-1125	T1B-CW6-1125	T1A-CW5-1125	T1A-CW4-1125
	T1B-CW5-1126	T1B-CW6-1126	T1A-CW5-1126	T1A-CW4-1126
	T1B-CW5-1127	T1B-CW6-1127	T1A-CW5-1127	T1A-CW4-1127
	T1B-CW5-1128	T1B-CW6-1128	T1A-CW5-1128	T1A-CW4-1128
	T1B-CW5-1129	T1B-CW6-1129	T1A-CW5-1129	T1A-CW4-1129
	T1B-CW5-1130	T1B-CW6-1130	T1A-CW5-1130	T1A-CW4-1130
	T1B-CW5-1131	T1B-CW6-1131	T1A-CW5-1131	T1A-CW4-1131
	T1B-CW5-1132	T1B-CW6-1132	T1A-CW5-1132	T1A-CW4-1132
	T1B-CW5-1133	T1B-CW6-1133	T1A-CW5-1133	T1A-CW4-1133
	T1B-CW5-1134	T1B-CW6-1134	T1A-CW5-1134	T1A-CW4-1134
	T1B-CW5-1135	T1B-CW6-1135	T1A-CW5-1135	T1A-CW4-1135
	T1B-CW5-1136	T1B-CW6-1136	T1A-CW5-1136	T1A-CW4-1136
	T1B-CW5-1137	T1B-CW6-1137	T1A-CW5-1137	T1A-CW4-1137
	T1B-CW5-1138	T1B-CW6-1138	T1A-CW5-1138	T1A-CW4-1138
	T1B-CW5-1139	T1B-CW6-1139	T1A-CW5-1139	T1A-CW4-1139
	T1B-CW5-1140	T1B-CW6-1140	T1A-CW5-1140	T1A-CW4-1140
	T1B-CW5-1141	T1B-CW6-1141	T1A-CW5-1141	T1A-CW4-1141
	T1B-CW5-1142	T1B-CW6-1142	T1A-CW5-1142	T1A-CW4-1142
	T1B-CW5-1143	T1B-CW6-1143	T1A-CW5-1143	T1A-CW4-1143
	T1B-CW5-1144	T1B-CW6-1144	T1A-CW5-1144	T1A-CW4-1144
	T1B-CW5-1145	T1B-CW6-1145	T1A-CW5-1145	T1A-CW4-1145
	T1B-CW5-1146	T1B-CW6-1146	T1A-CW5-1146	T1A-CW4-1146
	T1B-CW5-1147	T1B-CW6-1147	T1A-CW5-1147	T1A-CW4-1147
	T1B-CW5-1148	T1B-CW6-1148	T1A-CW5-1148	T1A-CW4-1148
	T1B-CW5-1149	T1B-CW6-1149	T1A-CW5-1149	T1A-CW4-1149
	T1B-CW5-1150	T1B-CW6-1150	T1A-CW5-1150	T1A-CW4-1150

1/16
1/2
1/4
1/8
1/16

T1B
E

T1B
E

上野

4/14

20/94