

工程指示 / 要求簡箋(E.I.)

工程指示編號：EI / 4995 / 22

修改版次：

工程編號：J - 858

工程名稱：將軍澳日出康城

工程項目：幕牆 地盆用配件 防火棉托+叉針

收件人：生統

發件人：Ant Yeung

日期：15/08/2022

要求提供 /  確認 事項：

- |                                    |                                     |                               |
|------------------------------------|-------------------------------------|-------------------------------|
| <input type="checkbox"/> 初步鋁料 B.M. | <input type="checkbox"/> 加工拆圖，然後生產  | <input type="checkbox"/> 尺寸表  |
| <input type="checkbox"/> 正式鋁料 B.M. | <input type="checkbox"/> 技術上資料 / 指示 | <input type="checkbox"/> 報價   |
| <input type="checkbox"/> 配件 B.M.   | <input type="checkbox"/> 樣辦或貨品說明書   | <input type="checkbox"/> 分判合約 |

內容：

請生產防火棉托+叉針 送地盆。先生產 T1 10 層數量

謝謝 *李銳*

請在 2022.09.12 前完成上列要求。

*其餘行地盆通知函於行*

附：

以上項目為：

- 原合約工程包                       原合約工程加 / 減賬                       新工程報價

原因：-

分發東莞各部門：

- |  |   |  |  |
|--|---|--|--|
| <input type="checkbox"/> 生產技術總監 <input type="checkbox"/> 連附件 | <input type="checkbox"/> 技術部 <input type="checkbox"/> 連附件                         | <input type="checkbox"/> 生產部 <input type="checkbox"/> 連附件                          | <input type="checkbox"/> 機械設計部 <input type="checkbox"/> 連附件        |
| <input type="checkbox"/> 採購部 <input type="checkbox"/> 連附件    | <input checked="" type="checkbox"/> 生產統籌部 <input checked="" type="checkbox"/> 連附件 | <input checked="" type="checkbox"/> 小羅 & 清 <input checked="" type="checkbox"/> 連附件 |  |
| <input type="checkbox"/> 質檢部 <input type="checkbox"/> 連附件    | <input type="checkbox"/> 會計部 <input type="checkbox"/> 連附件                         | <input type="checkbox"/> 報關組 <input type="checkbox"/> 連附件                          | <input type="checkbox"/> 其他 <i>李銳</i> <input type="checkbox"/> 連附件 |

分發香港各部門：*Bun*

- |   |  |   |   |
|---|--|---|---|
| <input type="checkbox"/> 行政部 <input type="checkbox"/> 連附件                       | <input type="checkbox"/> 會計部 <input type="checkbox"/> 連附件  | <input type="checkbox"/> 統籌部 <input type="checkbox"/> 連附件 | <input checked="" type="checkbox"/> 工程部地盤科文 <input checked="" type="checkbox"/> 連附件 <i>李銳</i> |
| <input checked="" type="checkbox"/> 採購部 <input checked="" type="checkbox"/> 連附件 | <input type="checkbox"/> QS 部 <input type="checkbox"/> 連附件 | <input type="checkbox"/> 維修部 <input type="checkbox"/> 連附件 | <input type="checkbox"/> 其他 _____ <input type="checkbox"/> 連附件                                |

傳遞編號：

HK 1348 / 22

發件人簽署：*Ant Yeung*

項目經理簽署：*Ant Yeung*

*T1 2056*

*T2 2030*

*T3 2032*

*6.11.2022*

## 預算完成生產日子 (10層1批)

EI4995			T1			T2 / T3				
					2	R/F	<b>Mo6</b>	<b>2023/05/29</b>		
					1	67/F				
			<b>Mo5</b>	<b>2023/03/31</b>	10	66/F	<b>Mo5</b>	<b>2023/05/15</b>		
					9	65/F				
8	48	62/F			8	63/F				
7	47	61/F			7	62/F				
6	46	60/F			6	61/F				
5	45	59/F			5	60/F				
4	44	58/F			4	59/F				
3	43	57/F			3	58/F				
2	42	56/F			2	57/F				
1	41	55/F			1	56/F				
10	40	53/F			10	55/F	<b>Mo4</b>	<b>2023/03/31</b>		
9	39	52/F			9	53/F				
8	38	51/F			8	52/F				
7	37	50/F			7	51/F				
6	36	49/F			6	50/F				
5	35	48/F			5	49/F				
4	34	47/F			4	48/F				
3	33	46/F			3	47/F				
2	32	45/F			2	46/F				
1	31	43/F			1	45/F				
10	30	42/F	<b>Mo3</b>	<b>2022/12/11</b>	10	43/F	<b>Mo3</b>	<b>2023/02/14</b>		
9	29	41/F							9	42/F
8	28	40/F							8	41/F
7	27	39/F							7	40/F
6	26	38/F							6	39/F
5	25	37/F							5	38/F
4	24	36/F							4	37/F
3	23	35/F							3	36/F
2	22	33/F							2	35/F
1	21	32/F							1	33/F
10	20	31/F	<b>Mo2</b>	<b>2022/10/27</b>	10	32/F	<b>Mo2</b>	<b>2022/12/11</b>		
9	19	30/F							9	31/F
8	18	29/F							8	30/F
7	17	28/F							7	29/F
6	16	27/F							6	28/F
5	15	26/F							5	27/F
4	14	25/F							4	26/F
3	13	23/F							3	25/F
2	12	22/F							2	23/F
1	11	21/F							1	22/F
10	10	20/F	<b>Mo1</b>	<b>2022/09/12</b>	10	21/F	<b>Mo1</b>	<b>2022/10/27</b>		
9	9	19/F							9	20/F
8	8	18/F							8	19/F
7	7	17/F							7	18/F
6	6	16/F							6	17/F
5	5	15/F							5	16/F
4	4	12/F							4	15/F
3	3	11/F							3	12/F
2	2	10/F							2	11/F
1	1	09/F							1	10/F

圖則登記表  
DRAWING REGISTER

工程名稱 Project Title:	康城11期 單元幕牆防火棉托 (T1, 2, 3)
工程編號 Project No:	J858

接收日期 Receiving Date (適用於客戶圖則)							
年							
月							
日							

分發予 Distributed To

發出日期 Issued Date							
年	22						
月	8						
日	2						

圖則編號 Drg. No.	圖則名稱 Drawing Title
J858-CW-FZ-01	J858單元幕牆防火棉托位置圖(T1)
J858-CW-FZ-02	J858單元幕牆防火棉托位置圖(T1)
J858-CW-FZ-03	J858單元幕牆防火棉托位置圖(T1)
J858-CW-FZ-04	J858單元幕牆防火棉托位置圖(T2)
J858-CW-FZ-05	J858單元幕牆防火棉托位置圖(T2)
J858-CW-FZ-06	J858單元幕牆防火棉托位置圖(T2)
J858-CW-FZ-07	J858單元幕牆防火棉托位置圖(T3)
J858-CW-FZ-08	J858單元幕牆防火棉托位置圖(T3)
J858-CW-FZ-09	J858單元幕牆防火棉托位置圖(T3)
FH-01	防火棉托加工圖
FH-02	防火棉托加工圖
FH-03	防火棉托加工圖
FH-04	防火棉托加工圖

修訂編號 Revision No.							
1	-						
2	-						
3	-						
4	-						
5	-						
6	-						
7	-						
8	-						
9	-						
10	-						
11	-						
12	-						
13							

 <b>美特鋁質有限公司</b> MIDI Aluminium Fabricator Ltd.				工程號	J858	類別		物料號	-		
				地盘	康城11期	制圖	W. E. X	2022-06-14	圖號	FH-01	
修改	-	-	-	採用工廠	✓	图纸名称	防火棉托加工图	復核	-	數量	-
日期	-	-	-	材料颜色	CHROMATE	材料	1.5mm厚铝板	批准	-	單件重量	- (KG)

部件编号	L	NxM	N1xM1
FH-01-01	419	1x200	1x300
FH-01-02	1510	3x300	4x300
FH-01-03	531	1x200	1x300
FH-01-04	1213	2x300	3x300
FH-01-05	1095	2x300	3x300
FH-01-06	1549	4x300	5x300
FH-01-07	1159	2x300	3x300
FH-01-08	1250	3x300	4x300
FH-01-09	550	1x200	1x300
FH-01-10	1413	3x300	4x300
FH-01-11	1680	4x300	5x300
FH-01-12	1490	3x300	4x300
FH-01-13	515	1x200	1x300
FH-01-14	1431	3x300	4x300
FH-01-15	1400	3x300	4x300
FH-01-16	1150	2x300	3x300
FH-01-17	1481	3x300	4x300
FH-01-18	1275	3x300	4x300
FH-01-19	1490	3x300	4x300

活化

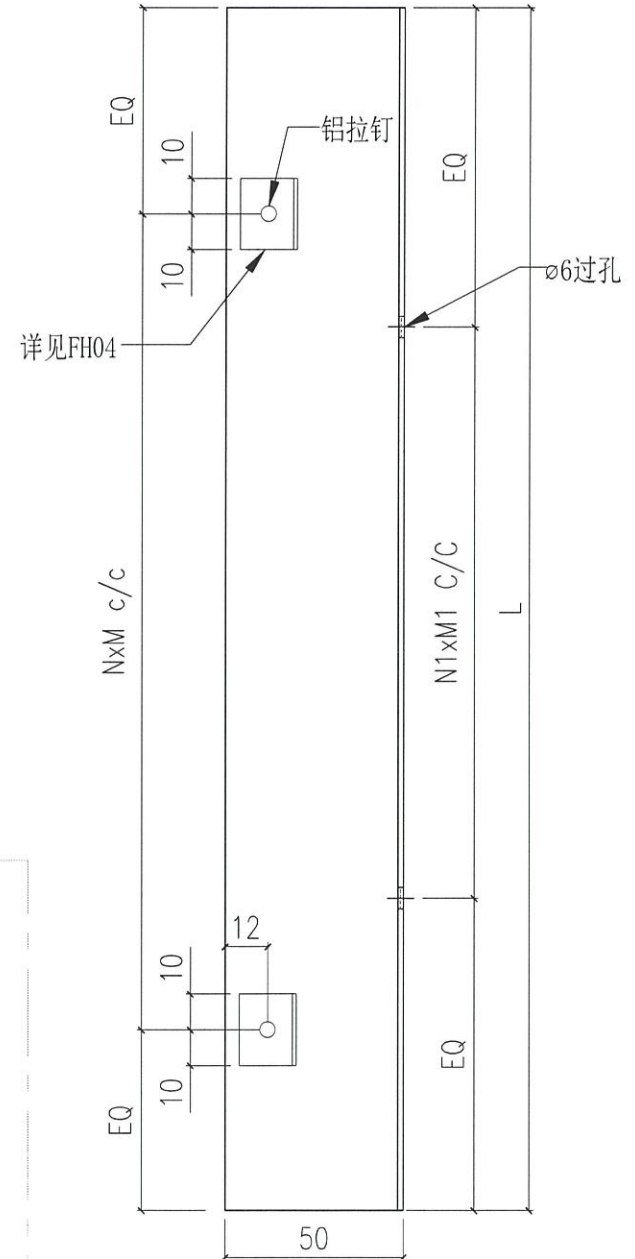
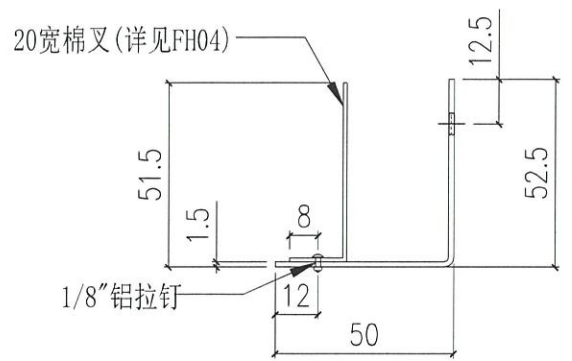

T1 205694

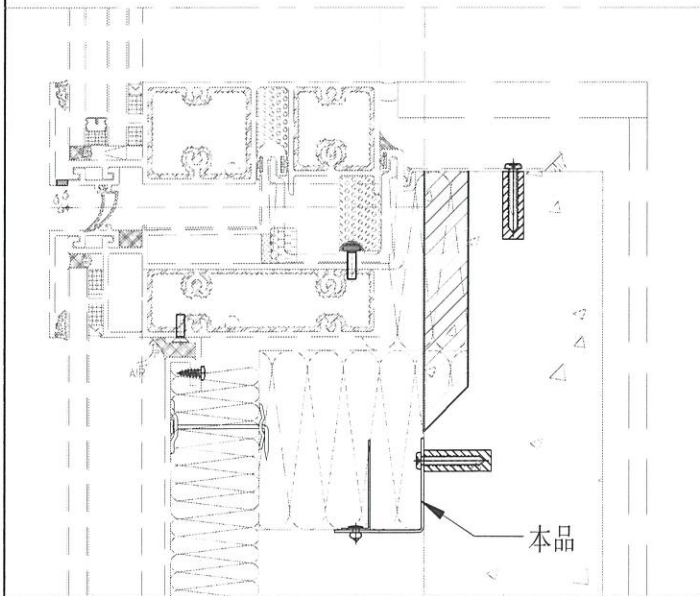

 <b>美特鋁質有限公司</b> MIDI Aluminium Fabricator Ltd.				工程號 J858 地盘 康城11期	類別 制圖 W. E. X	物料號 - 2022-06-14	圖號 FH-02
修改 - 日期 -	採用工廠 材料颜色 CHROMATE	地盤 ✓	图纸名称 防火棉托加工图 材料 1.5mm厚铝板	復核 - 批准 -	數量 - 單件重量 -	- (KG)	- -

部件编号	L	NxM	N1xM1
FH-02-01	419	1x200	1x300
FH-02-02	1509	3x300	4x300
FH-02-03	531	1x200	1x300
FH-02-04	1213	2x300	3x300
FH-02-05	1095	2x300	3x300
FH-02-06	1574	4x300	5x300
FH-02-07	1159	2x300	3x300
FH-02-08	1250	3x300	4x300
FH-02-09	550	1x200	1x300
FH-02-10	1413	3x300	4x300
FH-02-11	1705	4x300	5x300
FH-02-12	1578	4x300	5x300
FH-02-13	1540	4x200	5x300
FH-02-14	465	1x200	1x300
FH-02-15	600	1x200	1x300
FH-02-16	1630	4x300	5x300
FH-02-17	1506	3x300	4x300
FH-02-18	1213	2x300	3x300

Tr 203097

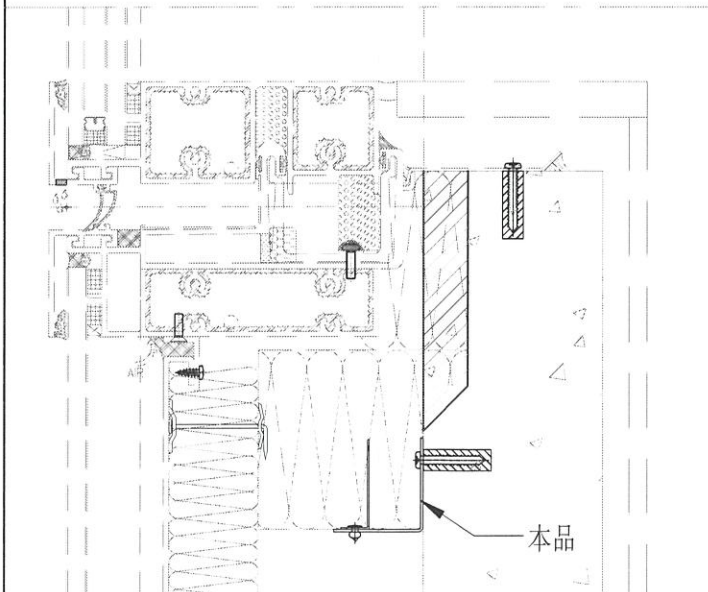
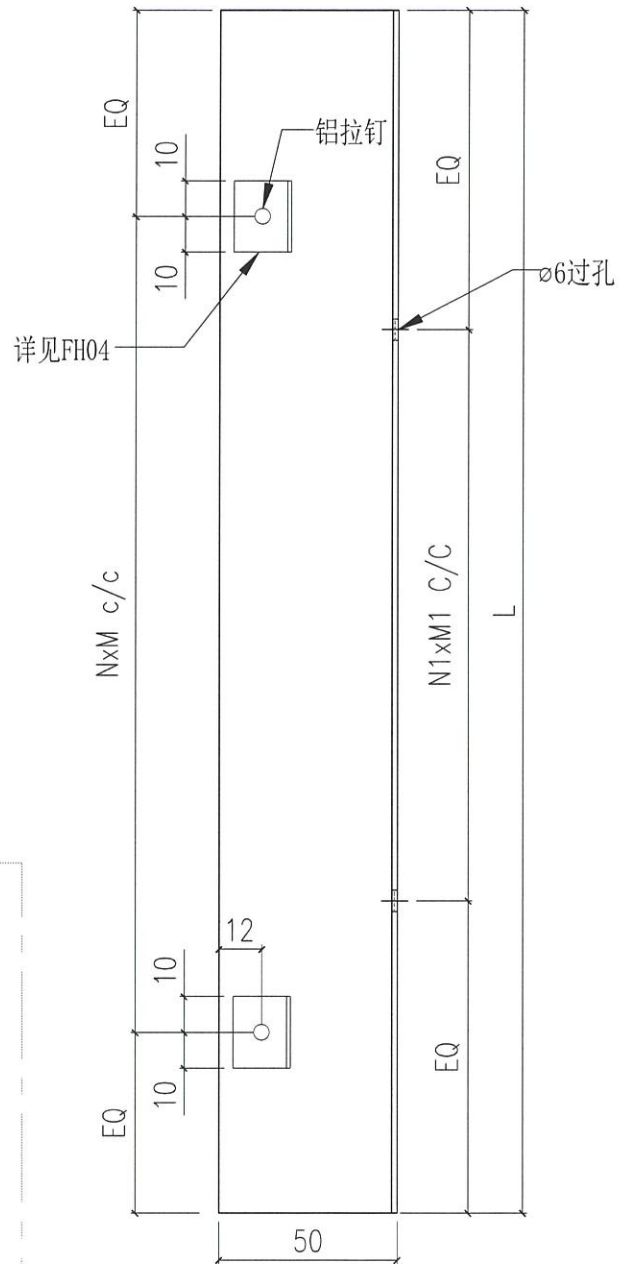
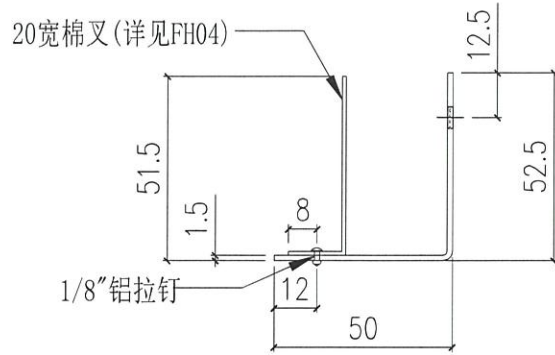

 <b>美特铝质有限公司</b> MIDI Aluminium Fabricator Ltd.				工程號 J858 地盘 康城11期	類別 制圖 W. E. X 復核 - 批准 -	物料號 - 2022-06-14 圖號 FH-03 數量 - 單件重量 - (KG)
修改 - 日期 -	採用工廠 材料颜色 CHROMATE	地盤 ✓ CHROMATE	图纸名称 防火棉托加工图 材料 1.5mm厚铝板			

部件编号	L	NxM	N1xM1
FH-03-01	419	1x200	1x300
FH-03-02	1478	3x300	4x300
FH-03-03	1095	2x300	3x300
FH-03-04	1213	2x300	3x300
FH-03-05	531	1x200	1x300
FH-03-06	1574	4x300	5x300
FH-03-07	1159	2x300	3x300
FH-03-08	1250	3x300	4x300
FH-03-09	550	1x200	1x300
FH-03-10	1413	3x300	4x300
FH-03-11	1705	4x300	5x300
FH-03-12	1540	3x300	4x300
FH-03-13	465	1x200	1x300
FH-03-14	600	1x200	1x300
FH-03-15	1509	3x300	4x300
FH-03-16	1506	3x300	4x300
FH-03-17	1176	2x300	3x300
FH-03-18	1275	3x300	4x300
FH-03-19	1492	3x300	4x300

合共 2032

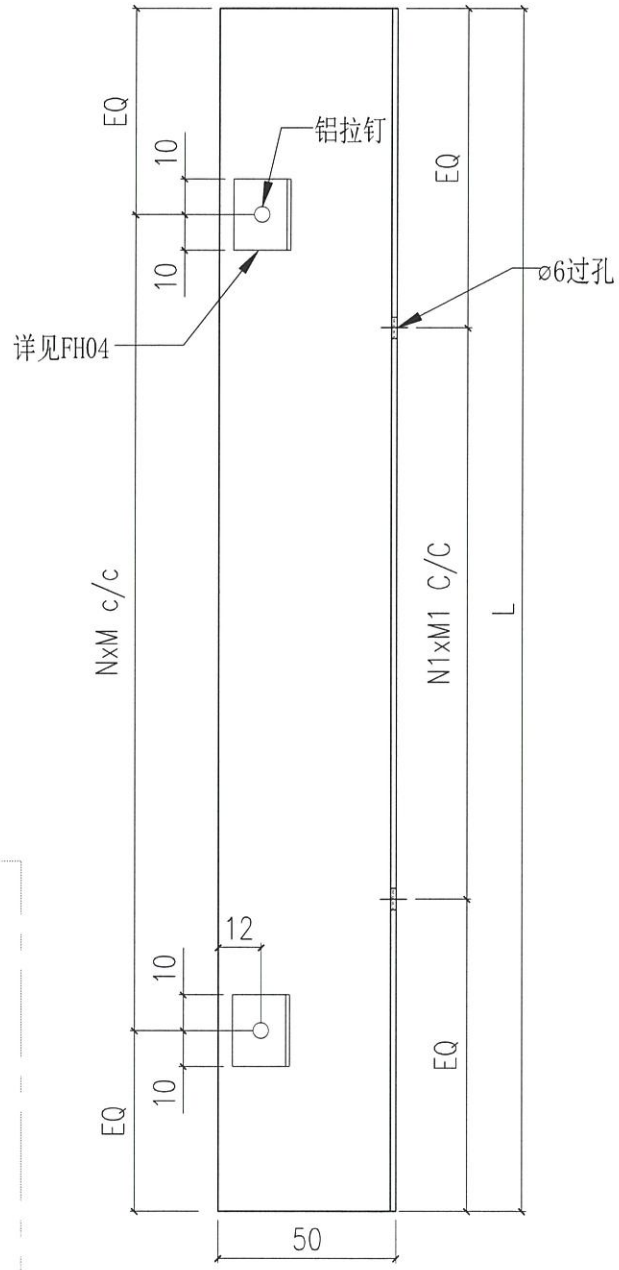
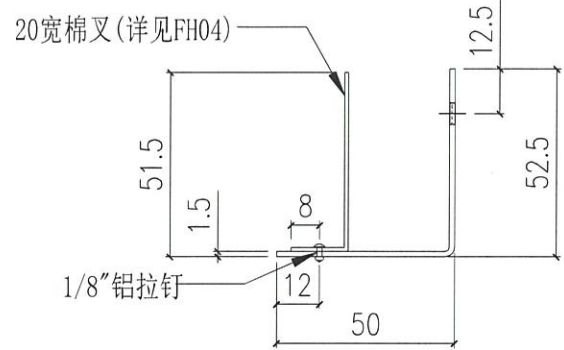

13 2032

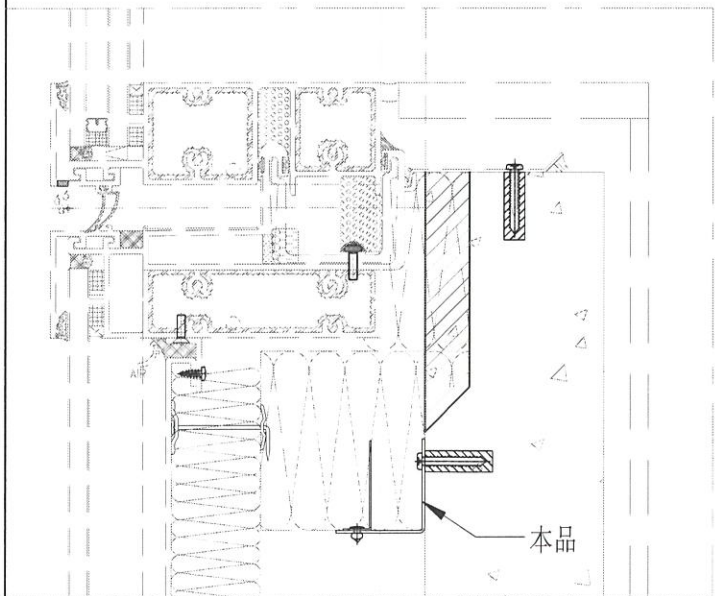

 美特鋁質有限公司 MIDI Aluminium Fabricator Ltd.				工程號	J858	類別		物料號	-					
				地盘	康城11期	制圖	W. E. X	2022-08-01	圖號	FH-04				
修改	-	-	-	採用工廠	✓	地盤		圖紙名稱	防火棉托加工圖	復核	-	-	數量	17500
日期	-	-	-	材料顏色	CHROMATE	材料	1mm厚鋁板	批准	-	-	單件重量	-	(KG)	

Handwritten signature or initials in blue ink.

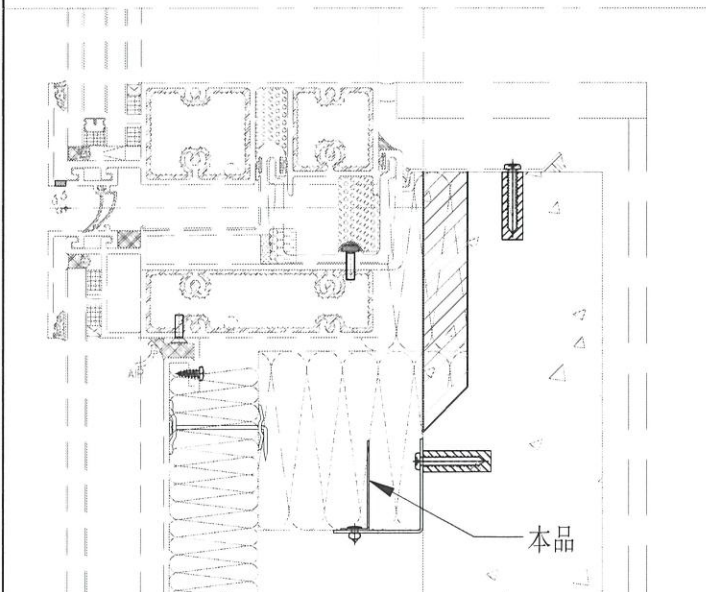
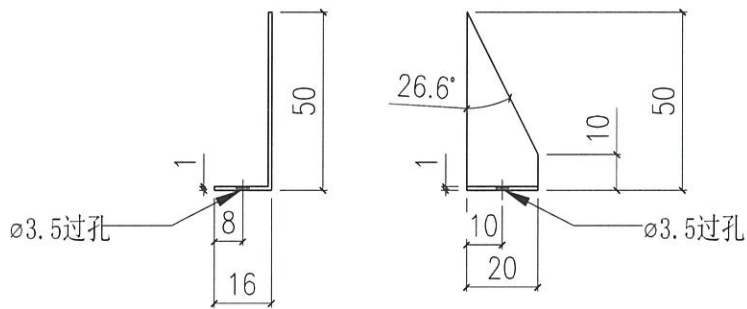

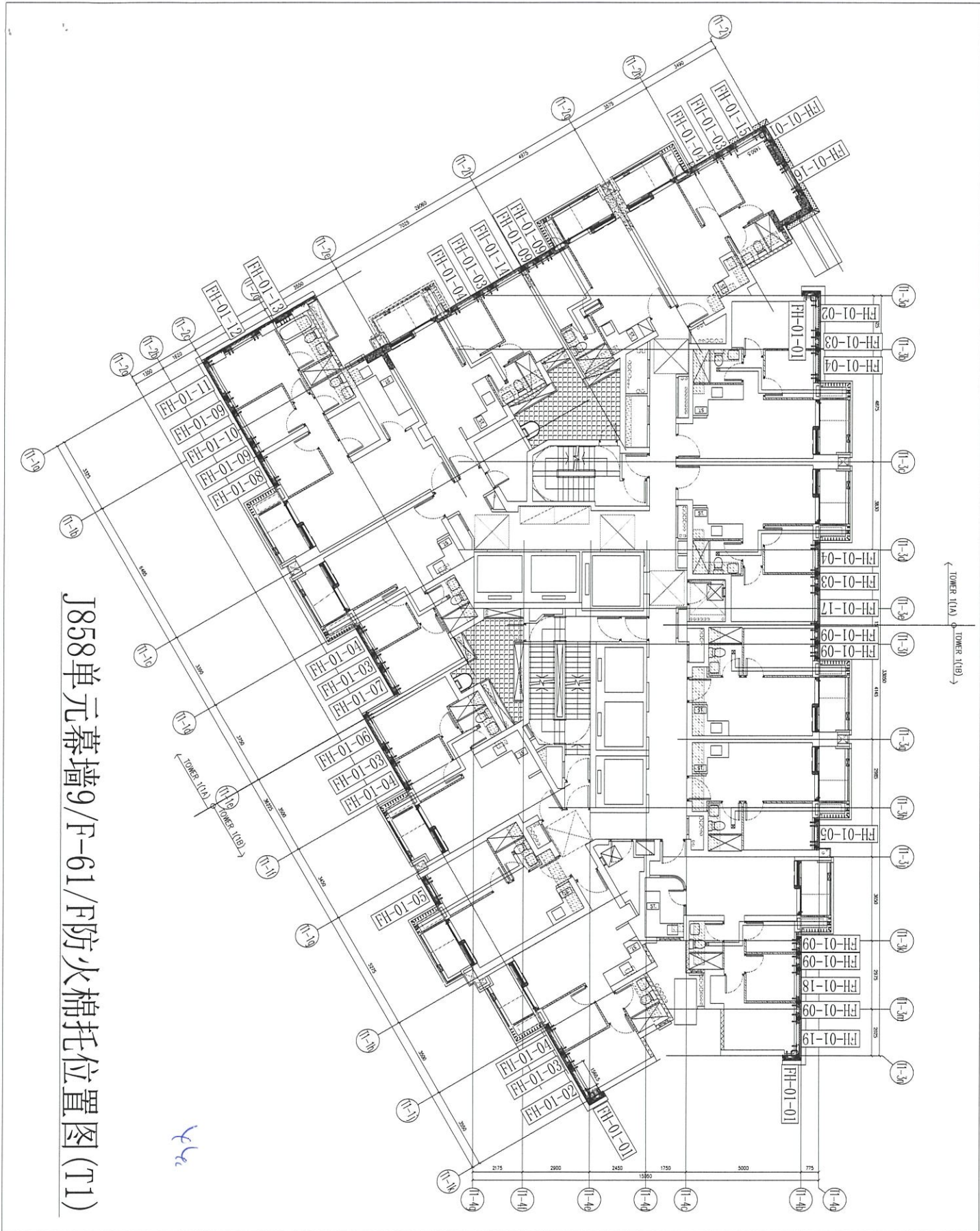

J858单元幕墙9/F-61/F防火棉托位置图(T1)

<p>B.D. REF. :</p>	<p>CLIENT :   佳和置業有限公司          Sino Land Company Limited</p>	<p>ARCHITECT :   conaldu          Conaldu Architects &amp; Interior Design          Ronald Lu &amp; Partners (HK) Ltd.          呂容軒建築師事務所(香港) 有限公司</p>	<p>STRUCTURAL ENGINEER :   Gammron          Gammron Engineering &amp; Construction</p>	<p>FAÇADE CONSULTANT :   AECOM          AECOM</p>	<p>NOTE :          1. ALL DIMENSIONS ARE IN mm.          2. ALL ELEVATIONS ARE VIEWED FROM OUTSIDE.          3. ALL DIMENSIONS TO BE VERIFIED ON SITE BEFORE FABRICATION.</p> <p>LEGEND :   DETAIL MARK NO.   REBAR SHEET NO.          1. F.F.L. --- FINISHED FLOOR LEVEL          2. S.F.L. --- STRUCTURAL FLOOR LEVEL          3.  --- REVERSED DETAIL</p>	<table border="1" style="width: 100%; border-collapse: collapse;"> <thead> <tr> <th>NO.</th> <th>DATE</th> <th>REVISION</th> <th>BY</th> </tr> </thead> <tbody> <tr> <td> </td> <td> </td> <td> </td> <td> </td> </tr> </tbody> </table> <p>JOB NO. : J-858</p> <p>PROJECT : PROPOSED RESIDENTIAL DEVELOPMENT AT MOKL 708P, PHASE 11, LOKWAS PARK, TSEUNG KWAN O, N.T.</p> <p>TITLE : TYPICAL FLOOR PLAN AT FLOOR 1</p> <p>DATE : 14-Jun-22 SCALE : 1:25(A1)</p> <p>DRAWN BY : KY CHECKED BY : YB</p> <p>DATE : 14-Jun-22 SCALE : 1:25(A1)</p> <p>DRAWN BY : KY CHECKED BY : YB</p>	NO.	DATE	REVISION	BY					<p>DMC NO. : J858-CW-FZ-01</p> <p>REV. : -</p>
NO.	DATE	REVISION	BY												





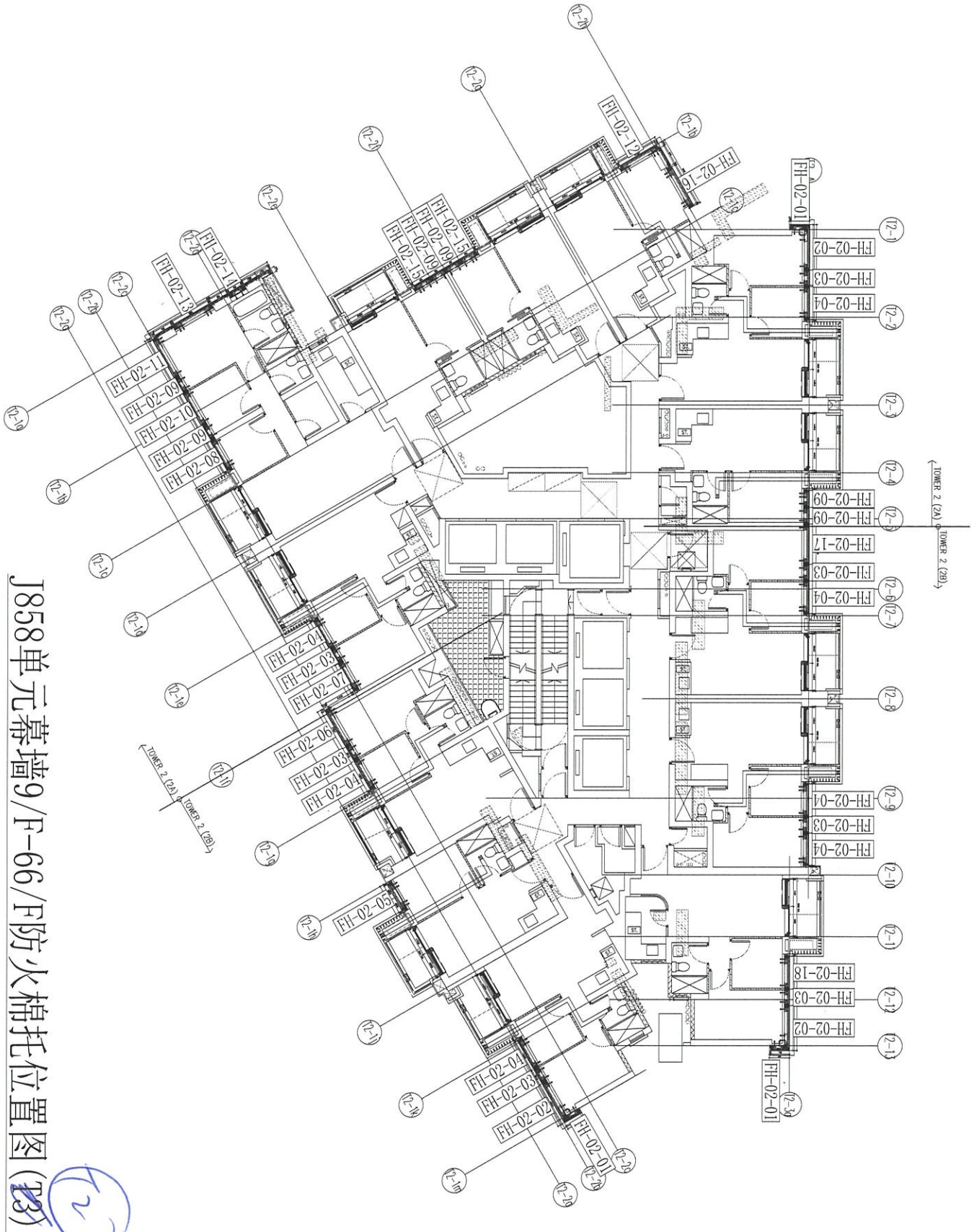

J858单元幕墙9/F-66/F防火棉托位置图 (1/2)

(1/2)

B.D. REF. :		
CLIENT : 恒和置業有限公司 Sino Land Company Limited		
ARCHITECT : ronald lu & partners Ronald Lu & Partners (HK) Ltd. 呂志祥建築師事務所 (香港) 有限公司		
STRUCTURAL ENGINEER : Gammon		
FACADE CONSULTANT : AECOM		
NOTE : 1. ALL DIMENSIONS ARE IN mm. 2. ALL DIMENSIONS ARE VIEWED FROM OUTSIDE BEFORE FABRICATION. 3. ALL DIMENSIONS TO BE VERIFIED ON SITE.		
LEGEND : ① --- VERTICAL MARK NO. ② --- HORIZONTAL MARK NO. ③ --- FINISHED FLOOR LEVEL ④ --- STRUCTURAL FLOOR LEVEL ⑤ --- REVERSED DETAIL		
NO.	DATE	REVISION
J858	14-Jun-22	1
JOB NO. : J-858		
PROJECT : PROPOSED RESIDENTIAL DEVELOPMENT AT KOTI 709P, PINKSE 11, LOKAS PARK, TSEUNG KWAN O, N.T.		
TITLE : TYPICAL FLOOR PLAN AT TOWER 1		
DATE : 14-Jun-22	SCALE : 1:250(A)	
DRAWN BY : KY	CHECKED BY : YB	
美特銘實有限公司 AECOM Architecture Ltd. Suite 5-18, Suning Building, 100, Des Voeux Road West, Hong Kong Tel: 852 28892111-4 Fax: 852 27277566 DWG NO. : J858-CW-FZ-04		
REV. :		



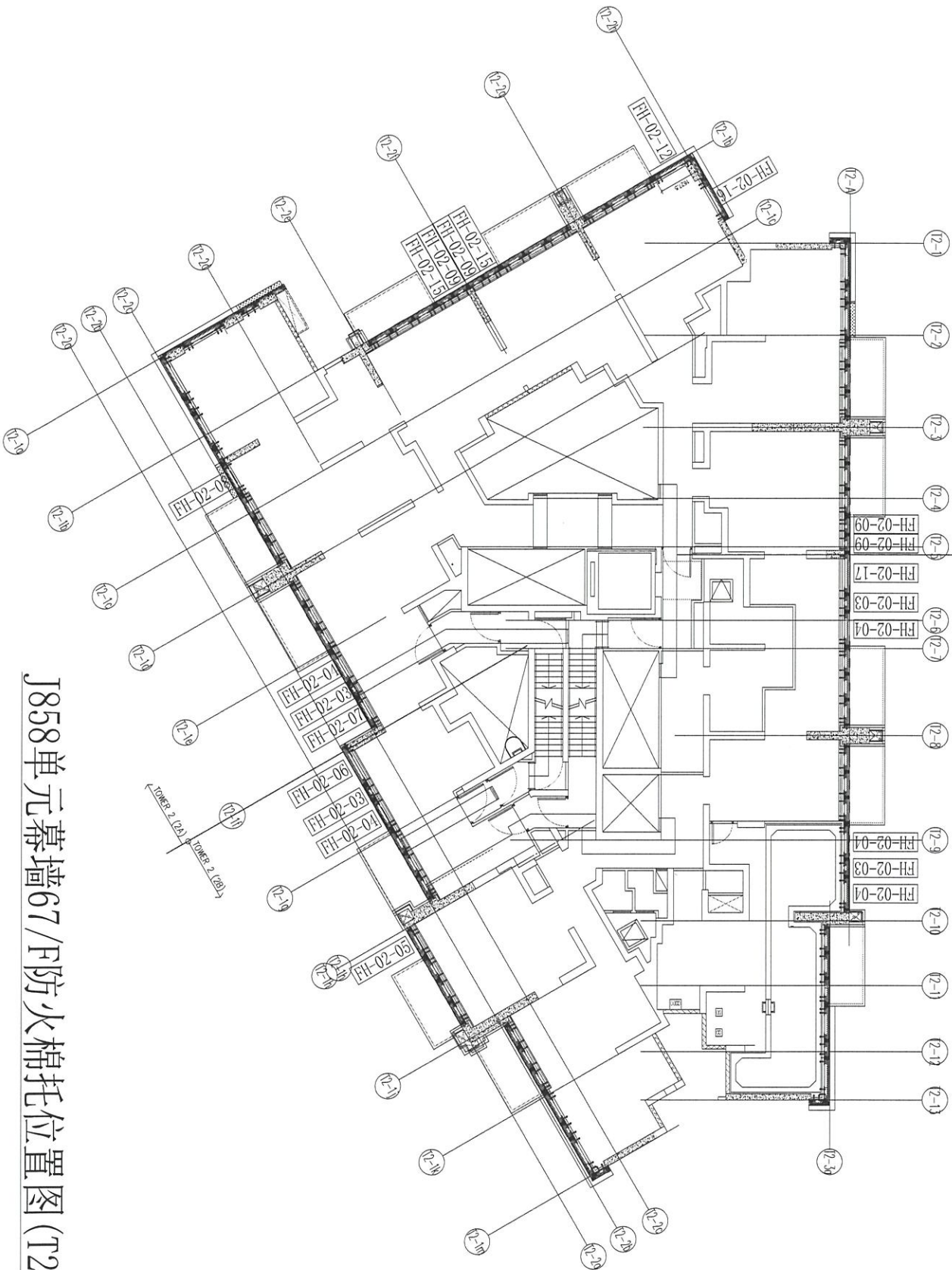

# J858单元幕墙67/F防火棉托位置图(T2)

B.O. REF. :

CLIENT : 信和置业有限公司  
Sino Land Company Limited

ARCHITECT : ronaldi lu  
Ronald Lu & Partners (HK) Ltd.  
呂和利建築師事務所 (信和) 有限公司

STRUCTURAL ENGINEER : Gammon

FAÇADE CONSULTANT : AECOM

AECOM

NOTE:  
1. ALL DIMENSIONS ARE IN mm.  
2. ALL DIMENSIONS ARE VIEWED FROM OUTSIDE BEFORE FABRICATION.  
3. ALL DIMENSIONS TO BE VERIFIED ON SITE.

LEGEND:  
XT --- DETAIL MARK NO.  
--- REFER SHEET NO.  
1. F.F.L. --- FINISHED FLOOR LEVEL  
2. S.F.L. --- STRUCTURAL FLOOR LEVEL  
3. --- REVERSED DETAIL

NO.	DATE	REVISION	BY
1			

JOB NO. : J-858

PROJECT : PROPOSED RESIDENTIAL DEVELOPMENT AT KOTI 709P, PHASE 11, URBAN PARK TSEUNG KWAN O, N.T.

TITLE : TYPICAL FLOOR PLAN AT TOWER 1

DATE : 14-Jun-22 SCALE : 1:250(A)

DESIGN BY : KY CHECKED BY : YB

美特銘實有限公司  
M.T.M. REAL ESTATE DEVELOPMENT LIMITED  
Units 5-8, Suning Industrial Centre, 11  
610 Chee Koo Ling Road, Kowloon  
Tel: 24489211-4 Fax: (852) 27275656  
DWC NO. : J858-CW-FZ-06 REV. : -

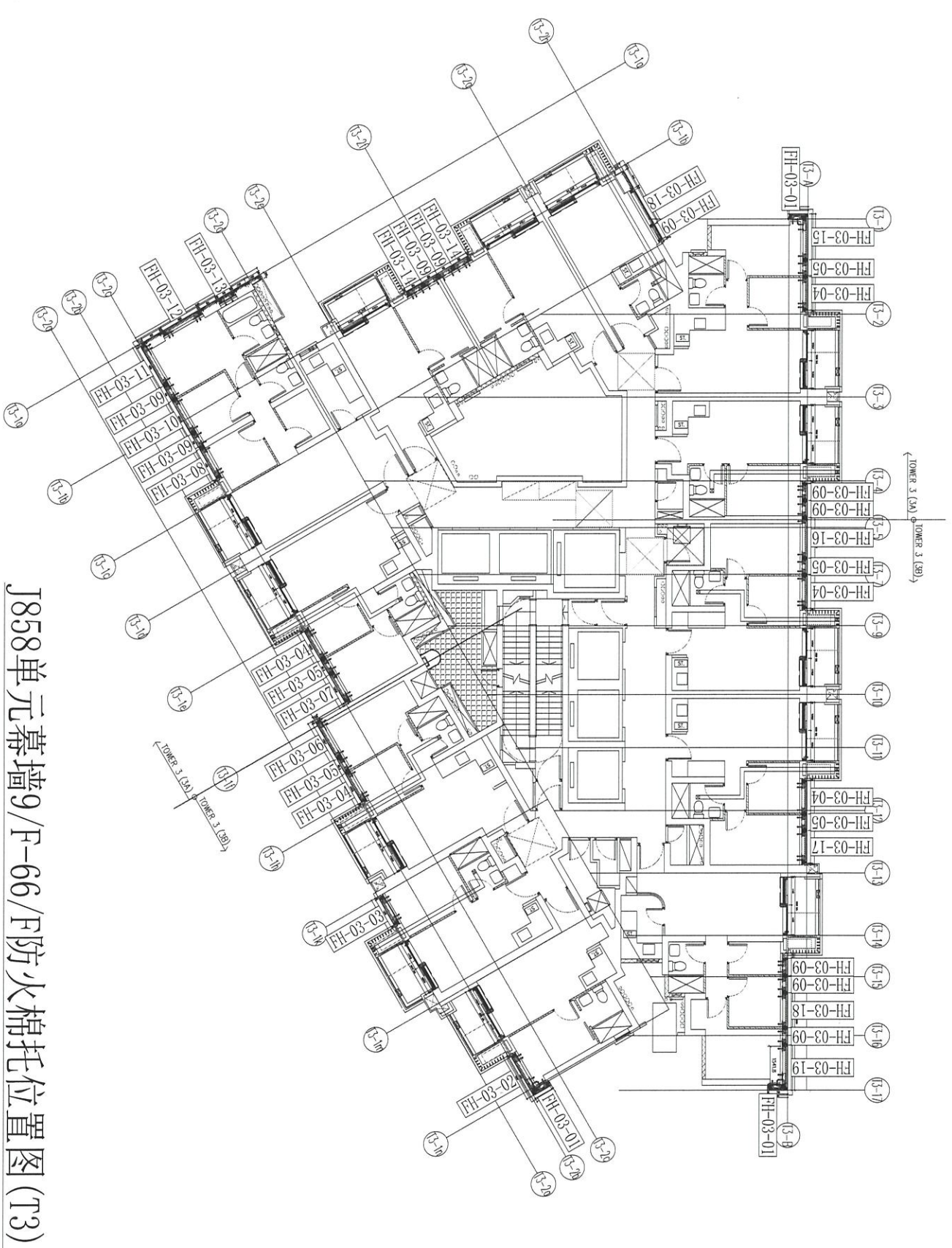

J858单元幕墙9/F-66/F防火棉托位置图 (T3)

B.O. REF. :			
CLIENT : 佳和置业有限公司 Sino Land Company Limited			
ARCHITECT : ronold lu Ronold Lu & Partners Ronald Lu & Partners (HK) Ltd. 2/F, 210 Des Voeux Road West, Hong Kong MAIN CONTRACTOR : 佳和有限公司			
STRUCTURAL ENGINEER : Gammon			
FACADE CONSULTANT : AECOM			
NOTE: 1. ALL DIMENSIONS ARE IN mm. 2. ALL ELEVATIONS ARE VIEWED FROM OUTSIDE. 3. ALL DIMENSIONS TO BE VERIFIED ON SITE BEFORE FABRICATION. LEGEND: (X) --- DETAIL MARK NO. (Y) --- REFER SHEET NO. 1. F.F.L. --- FINISHED FLOOR LEVEL 2. S.F.L. --- STRUCTURAL FLOOR LEVEL 3. (R) --- REVERSED DETAIL			
NO.	DATE	REVISION	BY
J-858			
JOB NO. : J-858			
PROJECT : PROPOSED RESIDENTIAL DEVELOPMENT AT KOTI 709P, PHASE 11, TOWNS PARK, TSEUNG KWAN O, N.T.			
DATE : 14-Jun-22 SCALE : 1:75(A1)			
DESIGN BY : KY	CHECKED BY : YB		
美特銘實業有限公司 MTD Real Estate Development Limited Units E-6, Sunny Industrial Centre, 610 Chee Koo Ling Road, Kwai Tsing Tel: 24892111-4 Fax: (852) 27277856 DMC NO. : J858-CM-FZ-07 REV. : -			





工程: J858康城11期

日期: 14-Jun-22

序号	部件图编号																
		9F	10F	11F	12F	15F	16F	17F	18F	19F	20F	21F	22F	23F	25F	26F	27F
1	FH-01-01	4	4	4	4	4	4	4	4	4	4	4	4	4	4	4	4
2	FH-01-02	2	2	2	2	2	2	2	2	2	2	2	2	2	2	2	2
3	FH-01-03	7	7	3	7	7	7	7	7	7	7	7	7	7	7	7	7
4	FH-01-04	7	7	3	7	7	7	7	7	7	7	7	7	7	7	7	7
5	FH-01-05	2	2	0	2	2	2	2	2	2	2	2	2	2	2	2	2
6	FH-01-06	1	1	0	1	1	1	1	1	1	1	1	1	1	1	1	1
7	FH-01-07	1	1	0	1	1	1	1	1	1	1	1	1	1	1	1	1
8	FH-01-08	1	1	1	1	1	1	1	1	1	1	1	1	1	1	1	1
9	FH-01-09	9	9	5	9	9	9	9	9	9	9	9	9	9	9	9	9
10	FH-01-10	1	1	1	1	1	1	1	1	1	1	1	1	1	1	1	1
11	FH-01-11	1	1	1	1	1	1	1	1	1	1	1	1	1	1	1	1
13	FH-01-12	1	1	1	1	1	1	1	1	1	1	1	1	1	1	1	1
15	FH-01-13	1	1	1	1	1	1	1	1	1	1	1	1	1	1	1	1
17	FH-01-14	1	1	0	1	1	1	1	1	1	1	1	1	1	1	1	1
18	FH-01-15	1	1	1	1	1	1	1	1	1	1	1	1	1	1	1	1
20	FH-01-16	1	1	1	1	1	1	1	1	1	1	1	1	1	1	1	1
23	FH-01-17	1	1	0	1	1	1	1	1	1	1	1	1	1	1	1	1
24	FH-01-18	1	1	1	1	1	1	1	1	1	1	1	1	1	1	1	1
25	FH-01-19	1	1	1	1	1	1	1	1	1	1	1	1	1	1	1	1
	分层数量	44	44	26	44	44	44	44	44	44	44	44	44	44	44	44	44

J858康城11期T1单元幕墙防火棉托数量分层统计表

28F	29F	30F	31F	32F	33F	35F	36F	37F	38F	39F	40F	41F	42F	43F	45F	46F	47F	48F	49F
4	4	4	4	4	4	4	4	4	4	4	4	4	4	4	4	4	4	4	4
2	2	2	2	2	2	2	2	2	2	2	2	2	2	2	2	2	2	2	2
7	7	7	7	7	7	7	7	7	7	7	3	7	7	7	7	7	7	7	7
7	7	7	7	7	7	7	7	7	7	7	3	7	7	7	7	7	7	7	7
2	2	2	2	2	2	2	2	2	2	2	0	2	2	2	2	2	2	2	2
1	1	1	1	1	1	1	1	1	1	1	0	1	1	1	1	1	1	1	1
1	1	1	1	1	1	1	1	1	1	1	0	1	1	1	1	1	1	1	1
1	1	1	1	1	1	1	1	1	1	1	1	1	1	1	1	1	1	1	1
9	9	9	9	9	9	9	9	9	9	9	5	9	9	9	9	9	9	9	9
1	1	1	1	1	1	1	1	1	1	1	1	1	1	1	1	1	1	1	1
1	1	1	1	1	1	1	1	1	1	1	1	1	1	1	1	1	1	1	1
1	1	1	1	1	1	1	1	1	1	1	1	1	1	1	1	1	1	1	1
1	1	1	1	1	1	1	1	1	1	1	1	1	1	1	1	1	1	1	1
1	1	1	1	1	1	1	1	1	1	1	0	1	1	1	1	1	1	1	1
1	1	1	1	1	1	1	1	1	1	1	1	1	1	1	1	1	1	1	1
1	1	1	1	1	1	1	1	1	1	1	1	1	1	1	1	1	1	1	1
1	1	1	1	1	1	1	1	1	1	1	0	1	1	1	1	1	1	1	1
1	1	1	1	1	1	1	1	1	1	1	1	1	1	1	1	1	1	1	1
1	1	1	1	1	1	1	1	1	1	1	1	1	1	1	1	1	1	1	1
1	1	1	1	1	1	1	1	1	1	1	1	1	1	1	1	1	1	1	1
44	44	44	44	44	44	44	44	44	44	44	26	44	44	44	44	44	44	44	44

												总数量	备注
50F	51F	52F	53F	55F	56F	57F	58F	59F	60F	61F	62F		
4	4	4	4	4	4	4	4	4	4	4	1	189	送地盘
2	2	2	2	2	2	2	2	2	2	2	0	94	送地盘
7	7	7	7	7	7	7	7	7	7	7	5	326	送地盘
7	7	7	7	7	7	7	7	7	7	7	5	326	送地盘
2	2	2	2	2	2	2	2	2	2	2	2	92	送地盘
1	1	1	1	1	1	1	1	1	1	1	1	46	送地盘
1	1	1	1	1	1	1	1	1	1	1	1	46	送地盘
1	1	1	1	1	1	1	1	1	1	1	1	48	送地盘
9	9	9	9	9	9	9	9	9	9	9	4	419	送地盘
1	1	1	1	1	1	1	1	1	1	1	0	47	送地盘
1	1	1	1	1	1	1	1	1	1	1	0	47	送地盘
1	1	1	1	1	1	1	1	1	1	1	0	47	送地盘
1	1	1	1	1	1	1	1	1	1	1	0	47	送地盘
1	1	1	1	1	1	1	1	1	1	1	1	46	送地盘
1	1	1	1	1	1	1	1	1	1	1	1	48	送地盘
1	1	1	1	1	1	1	1	1	1	1	1	48	送地盘
1	1	1	1	1	1	1	1	1	1	1	1	46	送地盘
1	1	1	1	1	1	1	1	1	1	1	0	47	送地盘
1	1	1	1	1	1	1	1	1	1	1	0	47	送地盘
44	44	44	44	44	44	44	44	44	44	44	24	2056	送地盘

工程: J858康城11期

日期: 14-Jun-22

序号	部件图编号																
		9F	10F	11F	12F	15F	16F	17F	18F	19F	20F	21F	22F	23F	25F	26F	27F
1	FH-02-01	3	3	3	3	3	3	3	3	3	3	3	3	3	3	3	3
2	FH-02-02	3	3	3	3	3	3	3	3	3	3	3	3	3	3	3	3
3	FH-02-03	7	7	4	7	7	7	7	7	7	7	7	7	7	7	7	7
4	FH-02-04	7	7	4	7	7	7	7	7	7	7	7	7	7	7	7	7
5	FH-02-05	1	1	0	1	1	1	1	1	1	1	1	1	1	1	1	1
6	FH-02-06	1	1	0	1	1	1	1	1	1	1	1	1	1	1	1	1
7	FH-02-07	1	1	0	1	1	1	1	1	1	1	1	1	1	1	1	1
8	FH-02-08	1	1	1	1	1	1	1	1	1	1	1	1	1	1	1	1
9	FH-02-09	6	6	2	6	6	6	6	6	6	6	6	6	6	6	6	6
10	FH-02-10	1	1	1	1	1	1	1	1	1	1	1	1	1	1	1	1
11	FH-02-11	1	1	1	1	1	1	1	1	1	1	1	1	1	1	1	1
12	FH-02-12	1	1	1	1	1	1	1	1	1	1	1	1	1	1	1	1
13	FH-02-13	1	1	1	1	1	1	1	1	1	1	1	1	1	1	1	1
15	FH-02-14	1	1	1	1	1	1	1	1	1	1	1	1	1	1	1	1
17	FH-02-15	2	2	0	2	2	2	2	2	2	2	2	2	2	2	2	2
19	FH-02-16	1	1	1	1	1	1	1	1	1	1	1	1	1	1	1	1
20	FH-02-17	1	1	0	1	1	1	1	1	1	1	1	1	1	1	1	1
21	FH-02-18	1	1	1	1	1	1	1	1	1	1	1	1	1	1	1	1
	分层数量	40	40	24	40	40	40	40	40	40	40	40	40	40	40	40	40

J858康城11期T2单元幕墙防火棉托数量分层统计表

28F	29F	30F	31F	32F	33F	35F	36F	37F	38F	39F	40F	41F	42F	43F	45F	46F	47F	48F	49F
3	3	3	3	3	3	3	3	3	3	3	3	3	3	3	3	3	3	3	3
3	3	3	3	3	3	3	3	3	3	3	3	3	3	3	3	3	3	3	3
7	7	7	7	7	7	7	7	7	7	7	4	7	7	7	7	7	7	7	7
7	7	7	7	7	7	7	7	7	7	7	4	7	7	7	7	7	7	7	7
1	1	1	1	1	1	1	1	1	1	1	0	1	1	1	1	1	1	1	1
1	1	1	1	1	1	1	1	1	1	1	0	1	1	1	1	1	1	1	1
1	1	1	1	1	1	1	1	1	1	1	0	1	1	1	1	1	1	1	1
1	1	1	1	1	1	1	1	1	1	1	1	1	1	1	1	1	1	1	1
6	6	6	6	6	6	6	6	6	6	6	2	6	6	6	6	6	6	6	6
1	1	1	1	1	1	1	1	1	1	1	1	1	1	1	1	1	1	1	1
1	1	1	1	1	1	1	1	1	1	1	1	1	1	1	1	1	1	1	1
1	1	1	1	1	1	1	1	1	1	1	1	1	1	1	1	1	1	1	1
1	1	1	1	1	1	1	1	1	1	1	1	1	1	1	1	1	1	1	1
1	1	1	1	1	1	1	1	1	1	1	1	1	1	1	1	1	1	1	1
2	2	2	2	2	2	2	2	2	2	2	0	2	2	2	2	2	2	2	2
1	1	1	1	1	1	1	1	1	1	1	1	1	1	1	1	1	1	1	1
1	1	1	1	1	1	1	1	1	1	1	0	1	1	1	1	1	1	1	1
1	1	1	1	1	1	1	1	1	1	1	1	1	1	1	1	1	1	1	1
40	40	40	40	40	40	40	40	40	40	40	24	40	40	40	40	40	40	40	40

50F	51F	52F	53F	55F	56F	57F	58F	59F	60F	61F	62F	63F	65F	66F	67F	总数量	备注
3	3	3	3	3	3	3	3	3	3	3	3	3	3	3	0	153	送地盘
3	3	3	3	3	3	3	3	3	3	3	3	3	3	3	0	153	送地盘
7	7	7	7	7	7	7	7	7	7	7	7	7	7	7	4	355	送地盘
7	7	7	7	7	7	7	7	7	7	7	7	7	7	7	5	356	送地盘
1	1	1	1	1	1	1	1	1	1	1	1	1	1	1	1	50	送地盘
1	1	1	1	1	1	1	1	1	1	1	1	1	1	1	1	50	送地盘
1	1	1	1	1	1	1	1	1	1	1	1	1	1	1	1	50	送地盘
1	1	1	1	1	1	1	1	1	1	1	1	1	1	1	1	52	送地盘
6	6	6	6	6	6	6	6	6	6	6	6	6	6	6	4	302	送地盘
1	1	1	1	1	1	1	1	1	1	1	1	1	1	1	0	51	送地盘
1	1	1	1	1	1	1	1	1	1	1	1	1	1	1	0	51	送地盘
1	1	1	1	1	1	1	1	1	1	1	1	1	1	1	1	52	送地盘
1	1	1	1	1	1	1	1	1	1	1	1	1	1	1	0	51	送地盘
1	1	1	1	1	1	1	1	1	1	1	1	1	1	1	0	51	送地盘
2	2	2	2	2	2	2	2	2	2	2	2	2	2	2	2	100	送地盘
1	1	1	1	1	1	1	1	1	1	1	1	1	1	1	1	52	送地盘
1	1	1	1	1	1	1	1	1	1	1	1	1	1	1	1	50	送地盘
1	1	1	1	1	1	1	1	1	1	1	1	1	1	1	0	51	送地盘
40	40	40	40	40	40	40	40	40	40	40	40	40	40	40	22	2030	送地盘

工程: J858康城11期

日期: 14-Jun-22

序号	部件图编号																	
		9F	10F	11F	12F	15F	16F	17F	18F	19F	20F	21F	22F	23F	25F	26F	27F	28F
1	FH-03-01	3	3	3	3	3	3	3	3	3	3	3	3	3	3	3	3	3
2	FH-03-02	1	1	1	1	1	1	1	1	1	1	1	1	1	1	1	1	1
3	FH-03-03	1	1	0	1	1	1	1	1	1	1	1	1	1	1	1	1	1
4	FH-03-04	5	5	1	5	5	5	5	5	5	5	5	5	5	5	5	5	5
5	FH-03-05	5	5	1	5	5	5	5	5	5	5	5	5	5	5	5	5	5
6	FH-03-06	1	1	0	1	1	1	1	1	1	1	1	1	1	1	1	1	1
7	FH-03-07	1	1	0	1	1	1	1	1	1	1	1	1	1	1	1	1	1
8	FH-03-08	1	1	1	1	1	1	1	1	1	1	1	1	1	1	1	1	1
9	FH-03-09	10	10	8	10	10	10	10	10	10	10	10	10	10	10	10	10	10
10	FH-03-10	1	1	1	1	1	1	1	1	1	1	1	1	1	1	1	1	1
11	FH-03-11	1	1	1	1	1	1	1	1	1	1	1	1	1	1	1	1	1
12	FH-03-12	1	1	1	1	1	1	1	1	1	1	1	1	1	1	1	1	1
13	FH-03-13	1	1	1	1	1	1	1	1	1	1	1	1	1	1	1	1	1
14	FH-03-14	2	2	2	2	2	2	2	2	2	2	2	2	2	2	2	2	2
15	FH-03-15	1	1	1	1	1	1	1	1	1	1	1	1	1	1	1	1	1
16	FH-03-16	1	1	0	1	1	1	1	1	1	1	1	1	1	1	1	1	1
17	FH-03-17	1	1	0	1	1	1	1	1	1	1	1	1	1	1	1	1	1
18	FH-03-18	2	2	2	2	2	2	2	2	2	2	2	2	2	2	2	2	2
19	FH-03-19	1	1	1	1	1	1	1	1	1	1	1	1	1	1	1	1	1
	分层数量	40	40	25	40	40	40	40	40	40	40	40	40	40	40	40	40	40

J858康城11期T3单元幕墙防火棉托数量分层统计表

29F	30F	31F	32F	33F	35F	36F	37F	38F	39F	40F	41F	42F	43F	45F	46F	47F	48F	49F	50F
3	3	3	3	3	3	3	3	3	3	3	3	3	3	3	3	3	3	3	3
1	1	1	1	1	1	1	1	1	1	1	1	1	1	1	1	1	1	1	1
1	1	1	1	1	1	1	1	1	1	0	1	1	1	1	1	1	1	1	1
5	5	5	5	5	5	5	5	5	5	1	5	5	5	5	5	5	5	5	5
5	5	5	5	5	5	5	5	5	5	1	5	5	5	5	5	5	5	5	5
1	1	1	1	1	1	1	1	1	1	0	1	1	1	1	1	1	1	1	1
1	1	1	1	1	1	1	1	1	1	0	1	1	1	1	1	1	1	1	1
1	1	1	1	1	1	1	1	1	1	1	1	1	1	1	1	1	1	1	1
10	10	10	10	10	10	10	10	10	10	8	10	10	10	10	10	10	10	10	10
1	1	1	1	1	1	1	1	1	1	1	1	1	1	1	1	1	1	1	1
1	1	1	1	1	1	1	1	1	1	1	1	1	1	1	1	1	1	1	1
1	1	1	1	1	1	1	1	1	1	1	1	1	1	1	1	1	1	1	1
1	1	1	1	1	1	1	1	1	1	1	1	1	1	1	1	1	1	1	1
2	2	2	2	2	2	2	2	2	2	2	2	2	2	2	2	2	2	2	2
1	1	1	1	1	1	1	1	1	1	1	1	1	1	1	1	1	1	1	1
1	1	1	1	1	1	1	1	1	1	0	1	1	1	1	1	1	1	1	1
1	1	1	1	1	1	1	1	1	1	0	1	1	1	1	1	1	1	1	1
2	2	2	2	2	2	2	2	2	2	2	2	2	2	2	2	2	2	2	2
1	1	1	1	1	1	1	1	1	1	1	1	1	1	1	1	1	1	1	1
40	40	40	40	40	40	40	40	40	40	25	40	40	40	40	40	40	40	40	40

51F	52F	53F	55F	56F	57F	58F	59F	60F	61F	62F	63F	65F	66F	67F	总数量	备注
3	3	3	3	3	3	3	3	3	3	3	3	3	3	0	153	送地盘
1	1	1	1	1	1	1	1	1	1	1	1	1	1	0	51	送地盘
1	1	1	1	1	1	1	1	1	1	1	1	1	1	1	50	送地盘
5	5	5	5	5	5	5	5	5	5	5	5	5	5	4	251	送地盘
5	5	5	5	5	5	5	5	5	5	5	5	5	5	4	251	送地盘
1	1	1	1	1	1	1	1	1	1	1	1	1	1	1	50	送地盘
1	1	1	1	1	1	1	1	1	1	1	1	1	1	1	50	送地盘
1	1	1	1	1	1	1	1	1	1	1	1	1	1	1	52	送地盘
10	10	10	10	10	10	10	10	10	10	10	10	10	10	5	511	送地盘
1	1	1	1	1	1	1	1	1	1	1	1	1	1	0	51	送地盘
1	1	1	1	1	1	1	1	1	1	1	1	1	1	0	51	送地盘
1	1	1	1	1	1	1	1	1	1	1	1	1	1	0	51	送地盘
1	1	1	1	1	1	1	1	1	1	1	1	1	1	0	51	送地盘
2	2	2	2	2	2	2	2	2	2	2	2	2	2	2	104	送地盘
1	1	1	1	1	1	1	1	1	1	1	1	1	1	0	51	送地盘
1	1	1	1	1	1	1	1	1	1	1	1	1	1	1	50	送地盘
1	1	1	1	1	1	1	1	1	1	1	1	1	1	1	50	送地盘
2	2	2	2	2	2	2	2	2	2	2	2	2	2	1	103	送地盘
1	1	1	1	1	1	1	1	1	1	1	1	1	1	0	51	送地盘
40	40	40	40	40	40	40	40	40	40	40	40	40	40	22	2032	送地盘