

工程指示 / 要求簡箋(E.I.)

工程指示編號：EI / 450 / 122 修改版次：-
 工程編號：J857 工程名稱：啟德 6552
 工程項目：後裝百葉 - 地盤用鐵件 BM
 收件人：Maggie Lor (羅小姐) 發件人：Yancy Chen 日期：23/03/2022

要求提供 / 確認 事項：

- | | | |
|------------------------------------|-------------------------------------|-------------------------------|
| <input type="checkbox"/> 初步鋁料 B.M. | <input type="checkbox"/> 加工拆圖，然後生產 | <input type="checkbox"/> 尺寸表 |
| <input type="checkbox"/> 正式鋁料 B.M. | <input type="checkbox"/> 技術上資料 / 指示 | <input type="checkbox"/> 報價 |
| <input type="checkbox"/> 配件 B.M. | <input type="checkbox"/> 樣辦或貨品說明書 | <input type="checkbox"/> 分判合約 |
| <input type="checkbox"/> 其他：_____ | | |

內容：

請按附件 BM 表和圖紙，生產 G.M.S.鐵件，按地盤要求，送地盤。

廠驗焊： Fillet Weld: 100%目測，10%磁粉。

驗焊報告：1) 項目名稱：Kai Tak Area 4C Site 2, Kai Tak, Kowloon - N.K.I.L.6552.

2) 位置：Superstructure - Aluminium Louvre.

請在 30/5/2022 前完成上列要求。

附：

1+ 21 頁

以上項目為：

原合約工程包 原合約工程加 / 減賬 新工程報價

原因：-

分發東莞各部門：

- () 生產技術總監 連附件 () 技術部 連附件 () 生產部 連附件 () 機械設計部 連附件
 () 採購部 連附件 () 生產統籌部 連附件
 () 質檢部 連附件 () 會計部 連附件 () 報關組 連附件 () 其他 _____ 連附件

分發香港各部門：

- () 行政部 連附件 () 會計部 連附件 () 統籌部 連附件 (/) 工程部地盤科文 連附件 明
 () 採購部 連附件 () QS 部 連附件 () 維修部 連附件 () 其他 _____ 連附件

傳遞編號：

發件人簽署： 

項目經理簽署： 

 美特鋁質 有限公司 MIDI Aluminum Fabricator Ltd.		工程號:	J-857	計算:	WYY	日期:	22/03/2022	送呈:施哥			
		地盤名稱:	啟德6552	核對:		日期:		副本:			
地盤用鐵件BM表		項目類別:	後裝百葉	批准:		日期:					
		修改版次:		A/C Code:		鐵件總重量KG:		1831.20	此BM依據最新施工圖資料計算		
序號	修改內容	鐵件圖號	圖紙名稱	顏色	實用	後備	總數	單位	單件 (kg)	總重量 (kg)	備注
1		J857-BY-TJ01	鐵件加工圖	熱浸鍍鋅+噴瀝青油	25	0	25	件	0.793	19.825	
2		J857-BY-TJ01R	鐵件加工圖	熱浸鍍鋅+噴瀝青油	25	0	25	件	0.793	19.825	
3		J857-BY-TJ02	鐵件加工圖	熱浸鍍鋅+噴瀝青油	3	0	3	件	31.596	94.787	
4		J857-BY-TJ03	鐵件加工圖	熱浸鍍鋅+噴瀝青油	3	0	3	件	31.596	94.787	
5		J857-BY-TJ04	鐵件加工圖	熱浸鍍鋅+噴瀝青油	1	0	1	件	25.774	25.774	
6		J857-BY-TJ05	鐵件加工圖	熱浸鍍鋅+噴瀝青油	1	0	1	件	25.774	25.774	
7		J857-BY-TJ06	鐵件加工圖	熱浸鍍鋅+噴瀝青油	1	0	1	件	27.293	27.293	
8		J857-BY-TJ07	鐵件加工圖	熱浸鍍鋅+噴瀝青油	1	0	1	件	27.293	27.293	
9		J857-BY-TJ08	鐵件加工圖	熱浸鍍鋅+噴瀝青油	1	0	1	件	25.152	25.152	
10		J857-BY-TJ09	鐵件加工圖	熱浸鍍鋅+噴瀝青油	7	0	7	件	44.943	314.599	
11		J857-BY-TJ10	鐵件加工圖	熱浸鍍鋅+噴瀝青油	1	0	1	件	32.516	32.516	
12		J857-BY-TJ11	鐵件加工圖	熱浸鍍鋅+噴瀝青油	8	0	8	件	26.441	211.529	
13		J857-BY-TJ12	鐵件加工圖	熱浸鍍鋅+噴瀝青油	1	0	1	件	19.998	19.998	
14		J857-BY-TJ13	鐵件加工圖	熱浸鍍鋅+噴瀝青油	1	0	1	件	35.278	35.278	
15		J857-BY-TJ14	鐵件加工圖	熱浸鍍鋅+噴瀝青油	1	0	1	件	22.161	22.161	
16		J857-BY-TJ15	鐵件加工圖	熱浸鍍鋅+噴瀝青油	43	0	43	件	2.763	118.818	
17		J857-BY-TJ16	鐵件加工圖	熱浸鍍鋅+噴瀝青油	43	0	43	件	2.763	118.818	
18		J857-BY-TT01	鐵件加工圖	熱浸鍍鋅	12	0	12	件	6.632	79.589	
19		J857-BY-TT02	鐵件加工圖	熱浸鍍鋅	13	0	13	件	8.255	107.317	
20		J857-BY-TT03	鐵件加工圖	熱浸鍍鋅	1	0	1	件	5.821	5.821	

 美特鋁質 有限公司 MEDI Aluminium Fabricator Ltd.		工程號: J-857	計算:	WYY	日期:	22/03/2022	送呈:施哥				
地盤名稱: 啟德6552		核對:						副本:			
項目類別: 後裝百葉		批准:									
修改版次:		A/C Code:	鐵件總重量KG:		1831.20			此BM依據最新施工圖資料計算			
序號	修改內容	鐵件圖號	圖紙名稱	顏色	實用	後備	總數	單位	單件 (kg)	總重量 (kg)	備注
21		J857-BY-TT04	鐵件加工圖	熱浸鍍鋅	14	0	14	件	12.312	172.364	
22		J857-BY-TT05	鐵件加工圖	熱浸鍍鋅	3	0	3	件	13.245	39.734	
23		J857-BY-TJ17	鐵件加工圖	熱浸鍍鋅+噴瀝青油	54	0	54	件	1.692	91.363	
24		J857-BY-TJ17R	鐵件加工圖	熱浸鍍鋅+噴瀝青油	54	0	54	件	1.692	91.363	
25		J857-BY-TJZ1	鐵件加工圖	熱浸鍍鋅	244	6	250	件	0.038	9.420	
26					合計:		567	件	合計:	1831.197	KG
加工說明 1.所有需燒焊之鐵件均需驗磁粉 ¹⁰ 20%,目測100%,除特別注明外,詳見附件8.56-1 2.所有鐵件均需熱浸鍍鋅,材質為Grade S275(BS EN10025 & EN10210) 3.加工成品分三批交地盤,到貨前需提前三至五天聯絡地盤負責人以便安排申請入關紙及告知來貨詳情											

圖則登記表
DRAWING REGISTER

圖則登記表 DRAWING REGISTER		接收日期 Receiving Date (適用於客戶圖則)																																																																																																																																																																																																																																																									
工程名稱 Project Title: 啟德6552	年	<table border="1" style="width:100%; height: 30px;"> <tr><td></td><td></td><td></td><td></td><td></td><td></td><td></td><td></td><td></td><td></td><td></td><td></td></tr> <tr><td></td><td></td><td></td><td></td><td></td><td></td><td></td><td></td><td></td><td></td><td></td><td></td></tr> <tr><td></td><td></td><td></td><td></td><td></td><td></td><td></td><td></td><td></td><td></td><td></td><td></td></tr> </table>																																																																																																																																																																																																																																																									
工程編號 Project No: J-857	月																																																																																																																																																																																																																																																										
	日																																																																																																																																																																																																																																																										
分發予 Distributed To		發出日期 Issued Date																																																																																																																																																																																																																																																									
		年	<table border="1" style="width:100%; height: 30px;"> <tr><td>22</td><td></td><td></td><td></td><td></td><td></td><td></td><td></td><td></td><td></td><td></td><td></td></tr> <tr><td>03</td><td></td><td></td><td></td><td></td><td></td><td></td><td></td><td></td><td></td><td></td><td></td></tr> <tr><td>22</td><td></td><td></td><td></td><td></td><td></td><td></td><td></td><td></td><td></td><td></td><td></td></tr> </table>										22												03												22																																																																																																																																																																																																																						
		22																																																																																																																																																																																																																																																									
		03																																																																																																																																																																																																																																																									
22																																																																																																																																																																																																																																																											
月																																																																																																																																																																																																																																																											
	日																																																																																																																																																																																																																																																										
圖則編號 Drg. No.	圖則名稱 Drawing Title	修訂編號 Revision No.																																																																																																																																																																																																																																																									
J857-BY-TJ01	鐵件加工圖	<table border="1" style="width:100%; height: 100%;"> <tr><td>-</td><td></td><td></td><td></td><td></td><td></td><td></td><td></td><td></td><td></td><td></td><td></td></tr> <tr><td>-</td><td></td><td></td><td></td><td></td><td></td><td></td><td></td><td></td><td></td><td></td><td></td></tr> <tr><td>-</td><td></td><td></td><td></td><td></td><td></td><td></td><td></td><td></td><td></td><td></td><td></td></tr> <tr><td>-</td><td></td><td></td><td></td><td></td><td></td><td></td><td></td><td></td><td></td><td></td><td></td></tr> <tr><td>-</td><td></td><td></td><td></td><td></td><td></td><td></td><td></td><td></td><td></td><td></td><td></td></tr> <tr><td>-</td><td></td><td></td><td></td><td></td><td></td><td></td><td></td><td></td><td></td><td></td><td></td></tr> <tr><td>-</td><td></td><td></td><td></td><td></td><td></td><td></td><td></td><td></td><td></td><td></td><td></td></tr> <tr><td>-</td><td></td><td></td><td></td><td></td><td></td><td></td><td></td><td></td><td></td><td></td><td></td></tr> <tr><td>-</td><td></td><td></td><td></td><td></td><td></td><td></td><td></td><td></td><td></td><td></td><td></td></tr> <tr><td>-</td><td></td><td></td><td></td><td></td><td></td><td></td><td></td><td></td><td></td><td></td><td></td></tr> <tr><td>-</td><td></td><td></td><td></td><td></td><td></td><td></td><td></td><td></td><td></td><td></td><td></td></tr> <tr><td>-</td><td></td><td></td><td></td><td></td><td></td><td></td><td></td><td></td><td></td><td></td><td></td></tr> <tr><td>-</td><td></td><td></td><td></td><td></td><td></td><td></td><td></td><td></td><td></td><td></td><td></td></tr> <tr><td>-</td><td></td><td></td><td></td><td></td><td></td><td></td><td></td><td></td><td></td><td></td><td></td></tr> <tr><td>-</td><td></td><td></td><td></td><td></td><td></td><td></td><td></td><td></td><td></td><td></td><td></td></tr> <tr><td>-</td><td></td><td></td><td></td><td></td><td></td><td></td><td></td><td></td><td></td><td></td><td></td></tr> <tr><td>-</td><td></td><td></td><td></td><td></td><td></td><td></td><td></td><td></td><td></td><td></td><td></td></tr> <tr><td>-</td><td></td><td></td><td></td><td></td><td></td><td></td><td></td><td></td><td></td><td></td><td></td></tr> <tr><td>-</td><td></td><td></td><td></td><td></td><td></td><td></td><td></td><td></td><td></td><td></td><td></td></tr> <tr><td>-</td><td></td><td></td><td></td><td></td><td></td><td></td><td></td><td></td><td></td><td></td><td></td></tr> </table>										-												-												-												-												-												-												-												-												-												-												-												-												-												-												-												-												-												-												-												-											
-																																																																																																																																																																																																																																																											
-																																																																																																																																																																																																																																																											
-																																																																																																																																																																																																																																																											
-																																																																																																																																																																																																																																																											
-																																																																																																																																																																																																																																																											
-																																																																																																																																																																																																																																																											
-																																																																																																																																																																																																																																																											
-																																																																																																																																																																																																																																																											
-																																																																																																																																																																																																																																																											
-																																																																																																																																																																																																																																																											
-																																																																																																																																																																																																																																																											
-																																																																																																																																																																																																																																																											
-																																																																																																																																																																																																																																																											
-																																																																																																																																																																																																																																																											
-																																																																																																																																																																																																																																																											
-																																																																																																																																																																																																																																																											
-																																																																																																																																																																																																																																																											
-																																																																																																																																																																																																																																																											
-																																																																																																																																																																																																																																																											
-																																																																																																																																																																																																																																																											
J857-BY-TJ01R	鐵件加工圖																																																																																																																																																																																																																																																										
J857-BY-TJ02	鐵件加工圖																																																																																																																																																																																																																																																										
J857-BY-TJ03	鐵件加工圖																																																																																																																																																																																																																																																										
J857-BY-TJ08	鐵件加工圖																																																																																																																																																																																																																																																										
J857-BY-TJ15	鐵件加工圖																																																																																																																																																																																																																																																										
J857-BY-TJ16	鐵件加工圖																																																																																																																																																																																																																																																										
J857-BY-TT01	鐵件加工圖																																																																																																																																																																																																																																																										
J857-BY-TJ17	鐵件加工圖																																																																																																																																																																																																																																																										
J857-BY-TJ17R	鐵件加工圖																																																																																																																																																																																																																																																										
J857-BY-TJZ1	鐵件加工圖																																																																																																																																																																																																																																																										
J857-IW-2014	派位圖																																																																																																																																																																																																																																																										
J857-IW-2015	派位圖																																																																																																																																																																																																																																																										
J857-IW-2016	派位圖																																																																																																																																																																																																																																																										
J857-IW-2018	派位圖																																																																																																																																																																																																																																																										
J857-IW-2019	派位圖																																																																																																																																																																																																																																																										
J857-IW-2020	派位圖																																																																																																																																																																																																																																																										
J857-IW-2031	派位圖																																																																																																																																																																																																																																																										

EG-DWG3



美特鋁質 有限公司
MIDI Aluminium Fabricator Ltd.

產品編號	L(MM)	數量	A	N	M	B	N1	M1	備註
		25							

工程號 J857 地盤 啓德6552

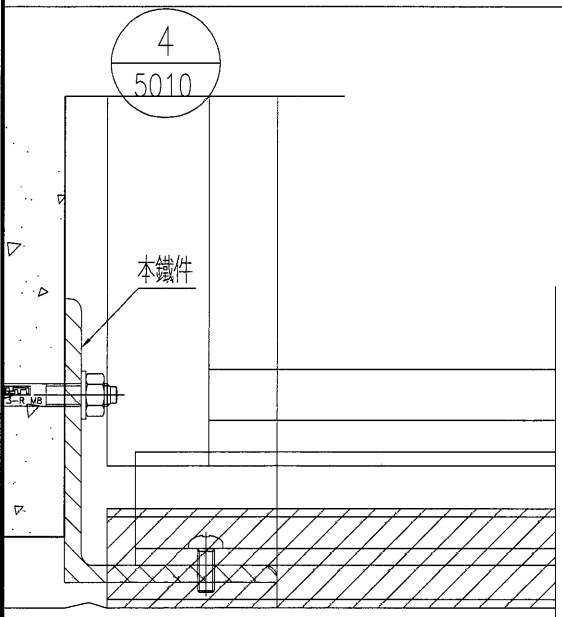
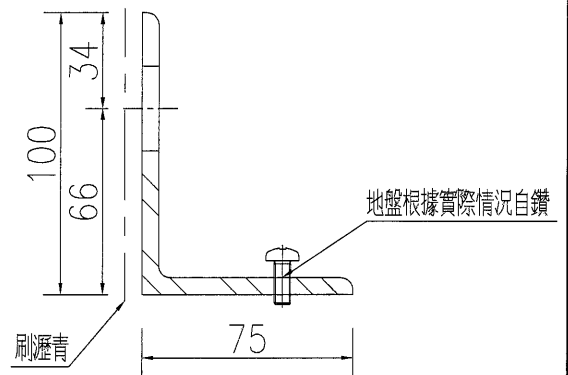
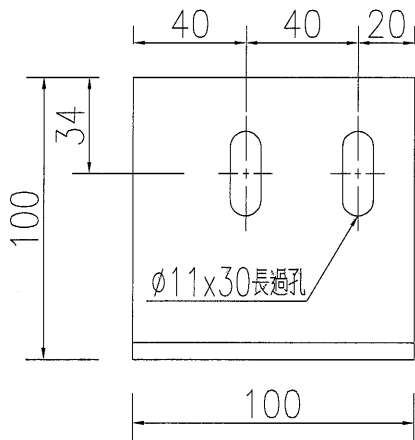

名稱	鐵件加工圖	制圖	WYY	2022-03-18	修改			
材料	100x75x6mm厚鐵角	復核			日期			
顏色	熱浸鍍鋅+刷瀝青	批准			圖號	J857-BY-TJ01		

EG-DWG3



美特鋁質 有限公司
MIDI Aluminium Fabricator Ltd.

產品編號	L(MM)	數量	A	N	M	B	N1	M1	備註
		25							

工程號	J857	地盤	啓德6552
-----	------	----	--------

地盤根據實際情況自鑽

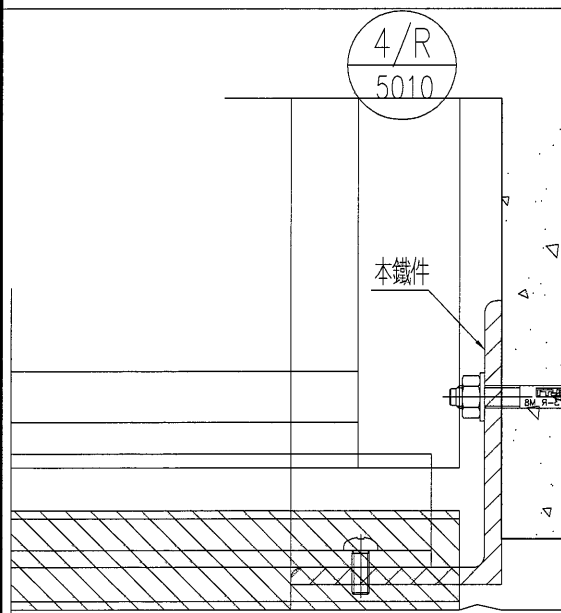
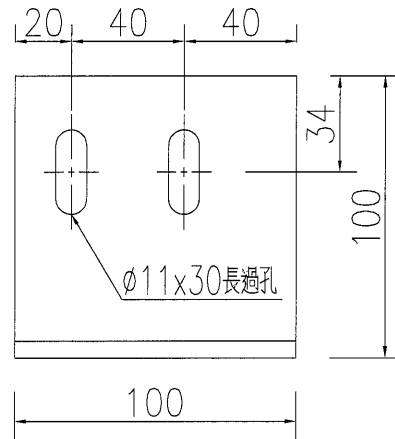
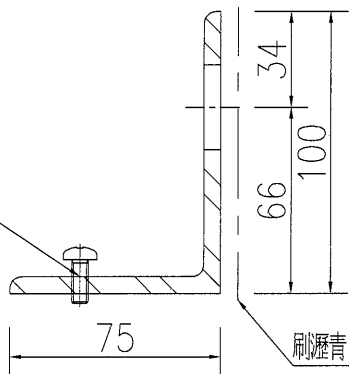

名稱	鐵件加工圖	制圖	WYY	2022-03-18	修改			
材料	100x75x6mm厚鐵角	復核			日期			
顏色	熱浸鍍鋅+刷瀝青	批准			圖號	J857-BY-TJ01R		

 美特鋁質 有限公司 MIDI Aluminium Fabricator Ltd.	序號	物料編號	長度L	數量	長度L1			
	1	J857-BY-TJ02	3450	3	3395			
	2	J857-BY-TJ04	2817.5	1	2762.5			
工程號	J857	地盤	啓德6552	3	J857-BY-TJ06	2982.5	1	2927.5

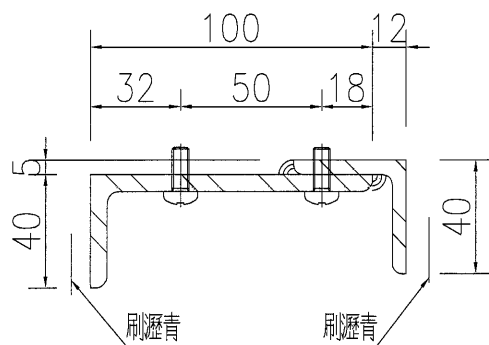
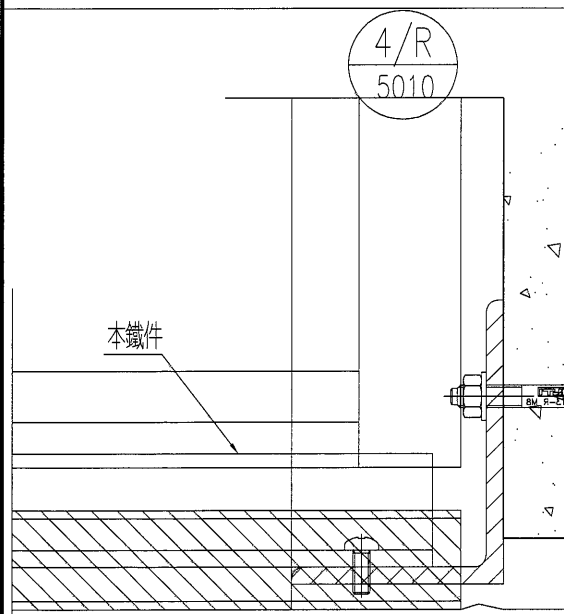
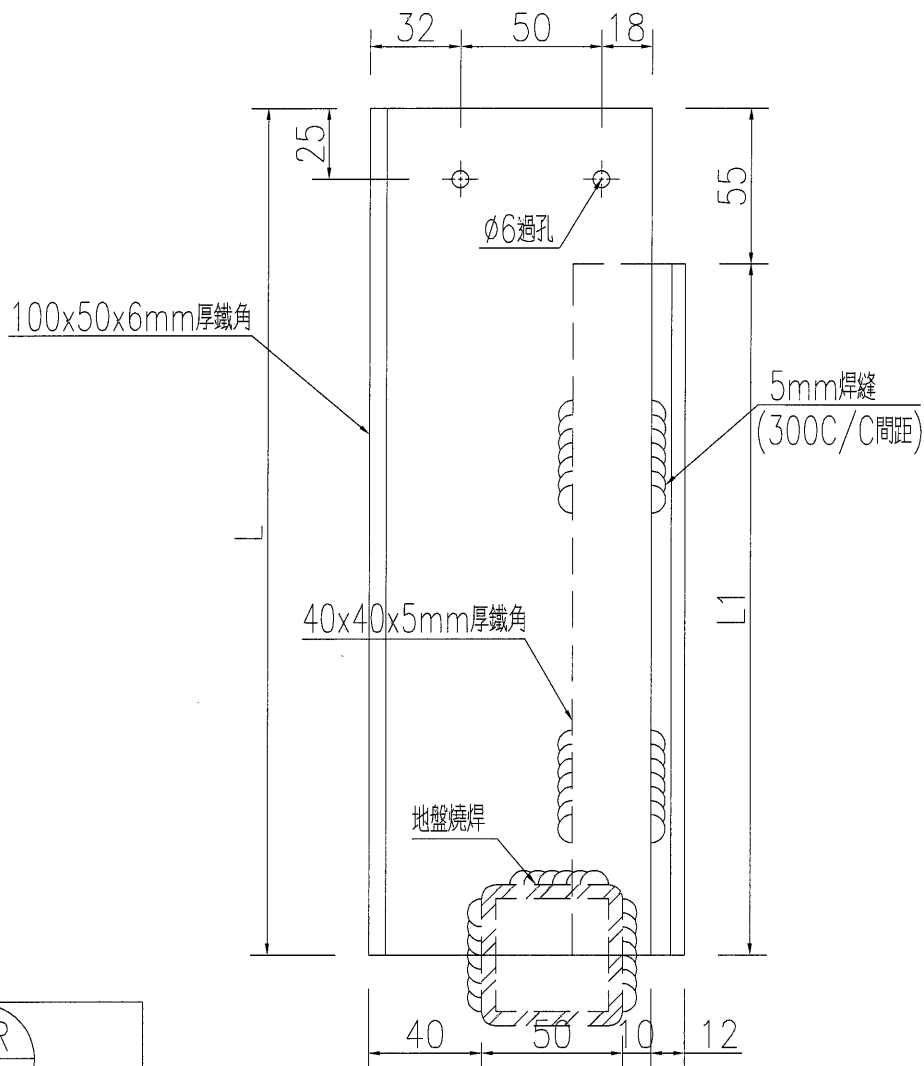

名稱	鐵件加工圖	制圖	WYY	2022-03-18	修改		
材料	詳見加工圖	復核			日期		
顏色	熱浸鍍鋅+刷瀝青	批准			圖號	J857-BY-TJ02	

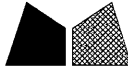
 美特鋁質有限公司 MIDI Aluminium Fabricator Ltd.	序號	物料編號	長度L	數量	長度L1			
	1	J857-BY-TJ03	3450	3	3395			
	2	J857-BY-TJ05	2817.5	1	2762.5			
工程號	J857	地盤	啓德6552	3	J857-BY-TJ07	2982.5	1	2927.5

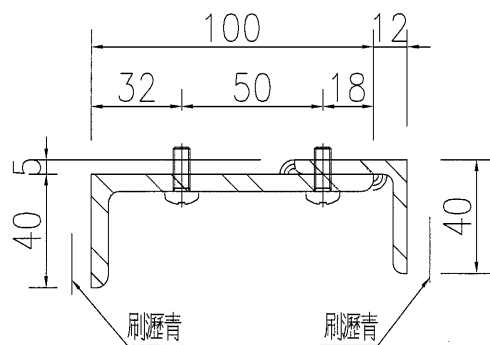
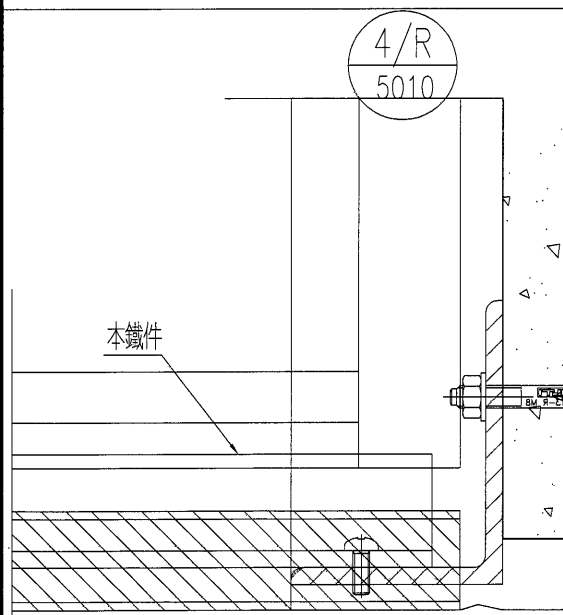
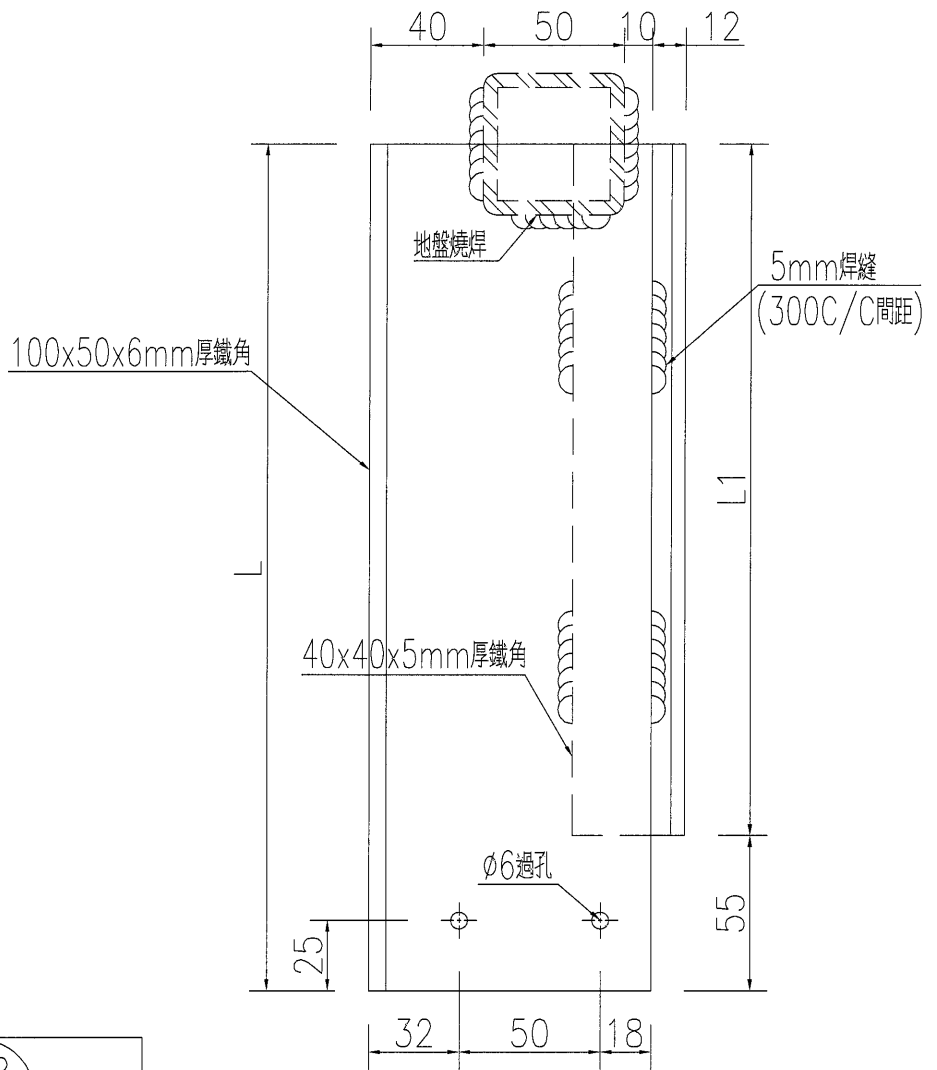

名稱	鐵件加工圖	制圖	WYY	2022-03-18	修改		
材料	詳見加工圖	復核			日期		
顏色	熱浸鍍鋅+刷瀝青	批准			圖號	J857-BY-TJ03	

 美特鋁質有限公司
MIDI Aluminium Fabricator Ltd.

工程號	J857	地盤	啓德6552
-----	------	----	--------

序號	物料編號	長度L	數量	長度L1
1	J857-BY-TJ08	2750	1	2695
2	J857-BY-TJ09	4900	7	4845
3	J857-BY-TJ10	3550	1	3495
4	J857-BY-TJ11	2890	8	2835
5	J857-BY-TJ12	2190	1	2135
6	J857-BY-TJ13	3850	1	3795
7	J857-BY-TJ14	2425	1	2370

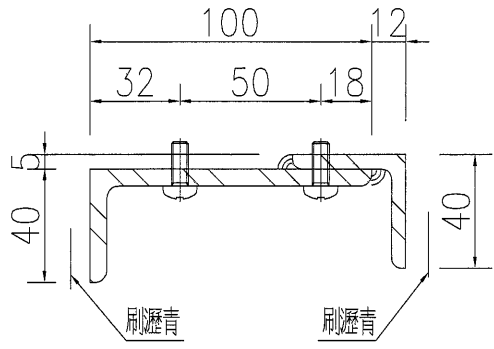
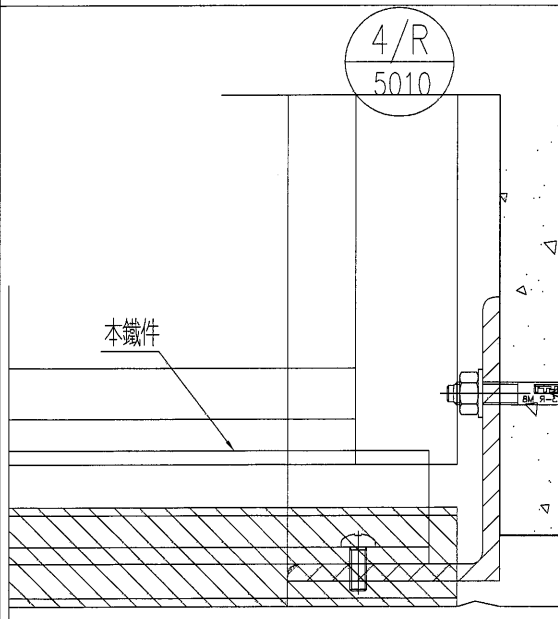
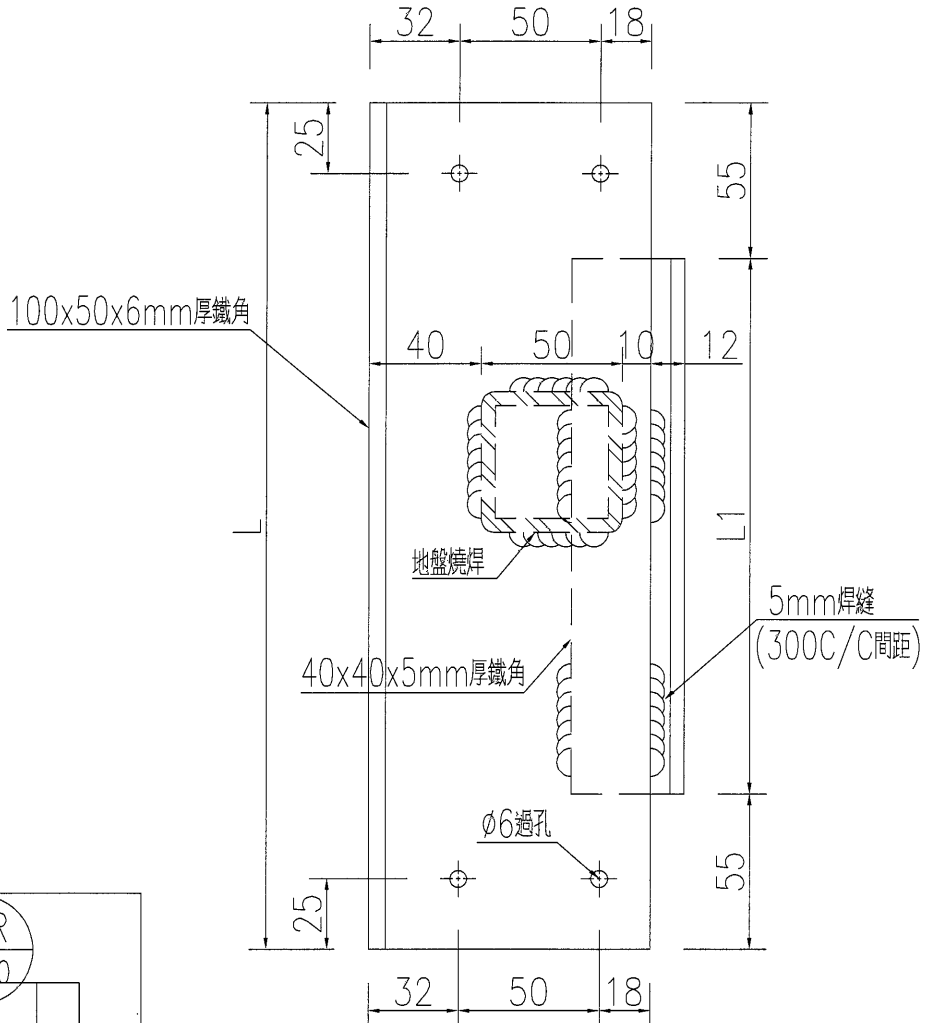

名稱	鐵件加工圖	制圖	WYY	2022-03-18	修改		
材料	詳見加工圖	復核			日期		
顏色	熱浸鍍鋅+刷瀝青	批准			圖號	J857-BY-TJ08	



美特鋁質 有限公司
MIDI Aluminium Fabricator Ltd.

產品編號	L(MM)	數量	A	N	M	B	N1	M1	備註
		43							

工程號	J857	地盤	啓德6552
-----	------	----	--------

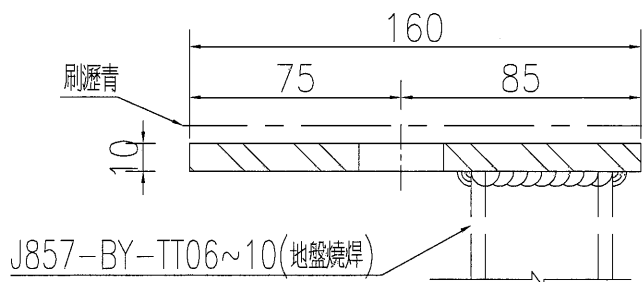
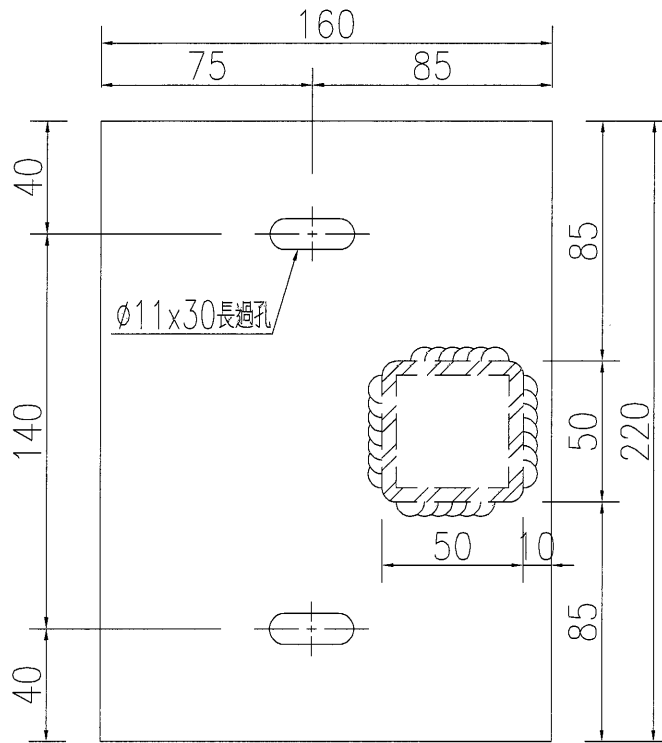

名稱	鐵件加工圖	制圖	WYY	2022-03-18	修改			
材料	220x160x10mm厚鐵巴	復核			日期			
顏色	熱浸鍍鋅+刷瀝青	批准			圖號	J857-BY-TJ15		



美特鋁質 有限公司
MIDI Aluminium Fabricator Ltd.

產品編號	L(MM)	數量	A	N	M	B	N1	M1	備註
		43							

工程號	J857	地盤	啓德6552
-----	------	----	--------

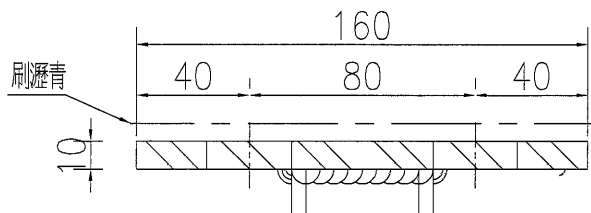
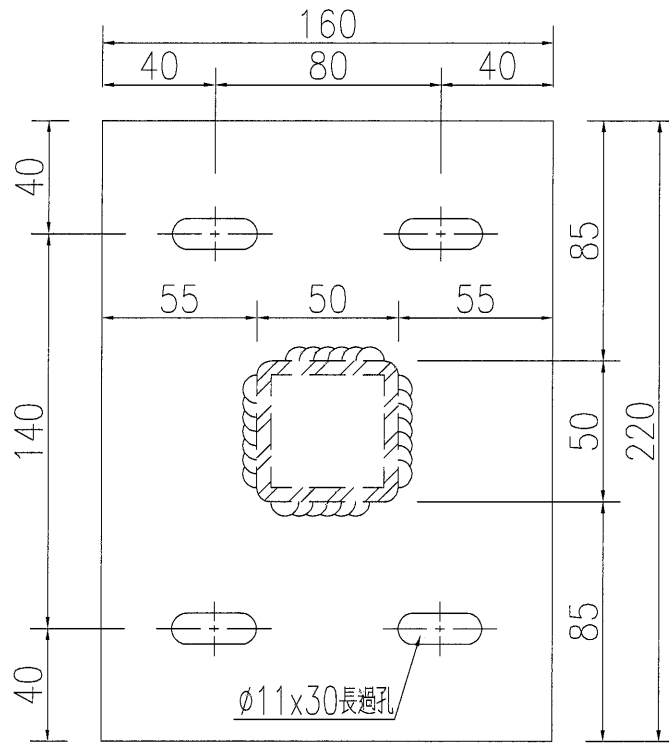

J857-BY-TT01~5(地盤燒焊)

名稱	鐵件加工圖	制圖	WYY	2022-03-18	修改		
材料	220x160x10mm厚鐵巴	復核			日期		
顏色	熱浸鍍鋅+刷瀝青	批准			圖號	J857-BY-TJ16	

EG-DWG3

美特鋁質 有限公司
 MIDI Aluminium Fabricator Ltd.

工程號 | J857 | 地盤 | 啓德6552

注：此斜位鐵通加長500mm，
 頂底根據地盤實際情況切角度。

序號	物料編號	長度L	數量
1	J857-BY-TT01	961.7	12
2	J857-BY-TT02	1197	13
3	J857-BY-TT03	844.1	1
4	J857-BY-TT04	1785.2	14
5	J857-BY-TT05	1920.5	3

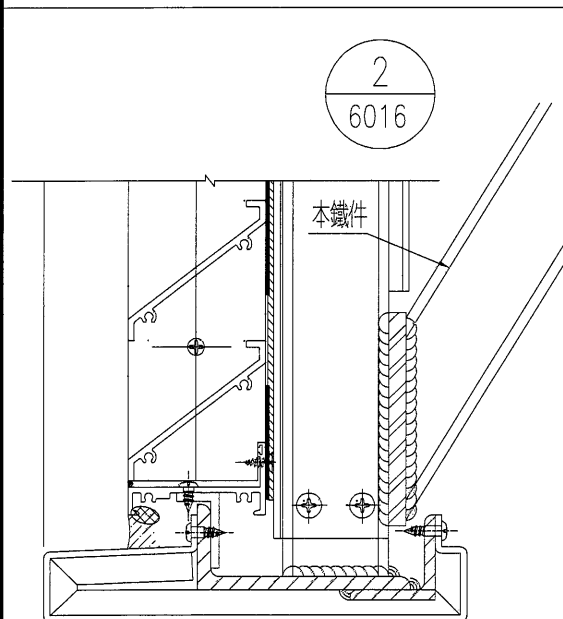
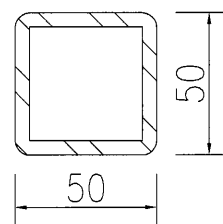
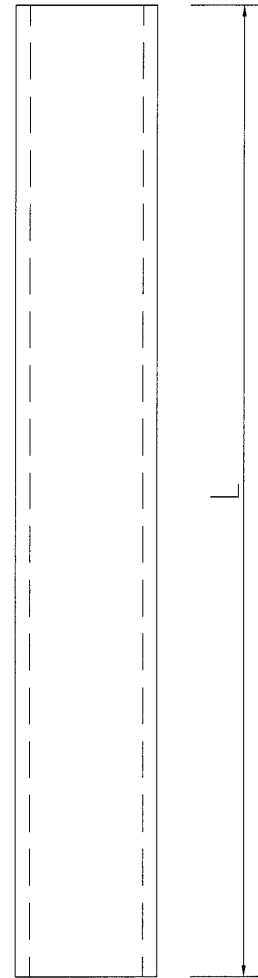

名稱	鐵件加工圖	制圖	WYY	2022-03-18	修改			
材料	50x50x5mm厚鐵通	復核			日期			
顏色	熱浸鍍鋅	批准			圖號	J857-BY-TT01		

 美特鋁質 有限公司 MIDI Aluminium Fabricator Ltd.			
工程號	J857	地盤	啓德6552

產品編號	L(MM)	數量	A	N	M	B	N1	M1	備註
		54							

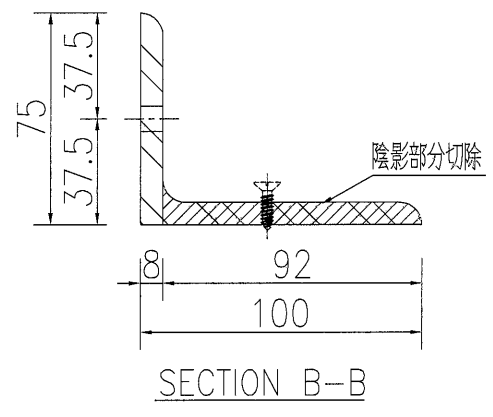
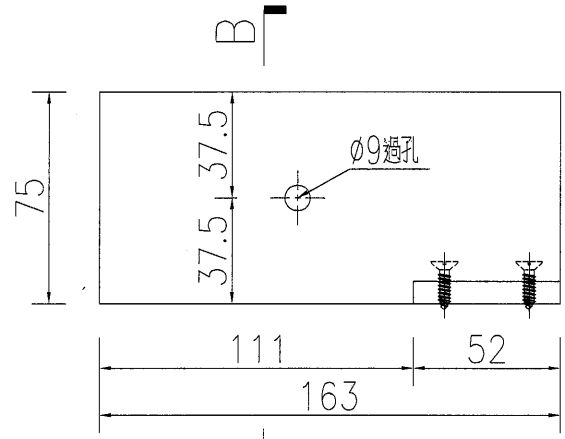
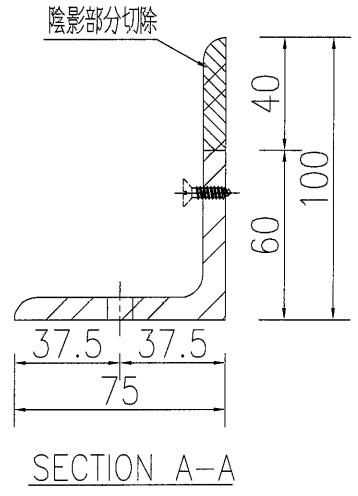
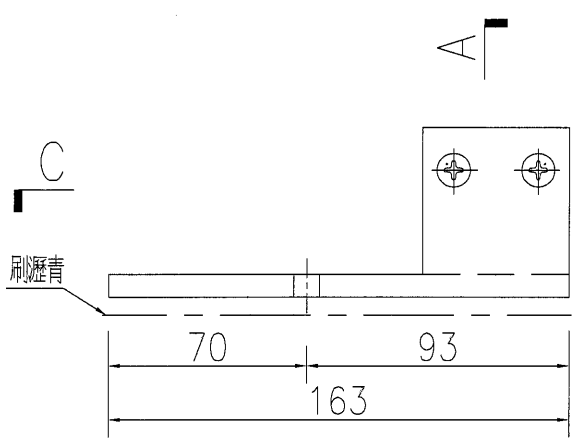

SECTION C-C

名稱	鐵件加工圖	制圖	WYY	2022-03-18	修改			
材料	100x75x8mm厚鐵角	復核			日期			
顏色	熱浸鍍鋅+刷瀝青	批准			圖號	J857-BY-TJ17		

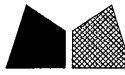

美特鋁質 有限公司
MIDI Aluminium Fabricator Ltd.

產品編號	L(MM)	數量	A	N	M	B	N1	M1	備註
		54							

工程號 | J857 | 地盤 | 啓德6552

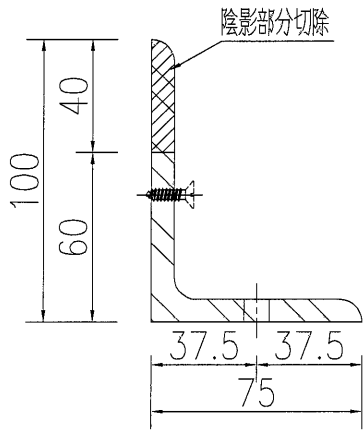

SECTION A-A

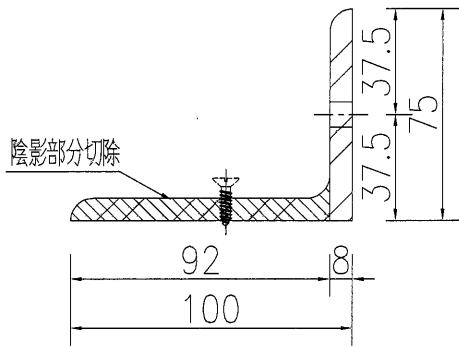
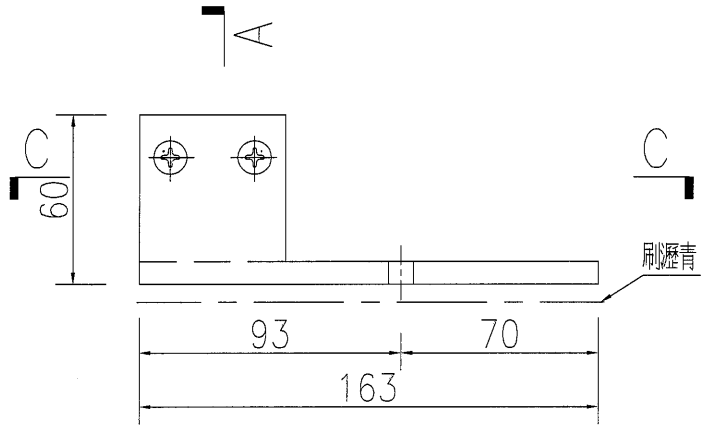

SECTION B-B

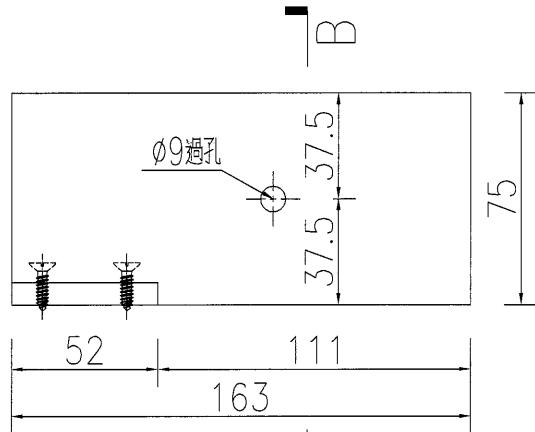

SECTION C-C

名稱	鐵件加工圖	制圖	WYY	2022-03-18	修改			
材料	100x75x8mm厚鐵角	復核			日期			
顏色	熱浸鍍鋅+刷瀝青	批准			圖號	J857-BY-TJ17R		

EG-DWG3

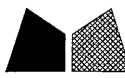

美特鋁質 有限公司
MIDI Aluminium Fabricator Ltd.

產品編號	L(MM)	數量	A	N	M	B	N1	M1	備註
		250							

工程號	J857	地盤	啓德6552
-----	------	----	--------

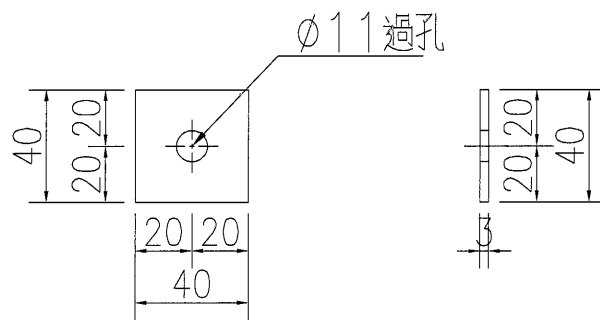

名稱	鐵件加工圖	制圖	WYY	2022-03-18	修改			
材料	40x40x3鐵巴	復核			日期			
顏色	熱浸鍍鋅	批准			圖號	J857-BY-TJZ1		

LOWER MARK	AL 01	AL 02	AL 03
ELEVATION (VIEWED FROM THE OUTSIDE)			
SECTION :	65mm ALUM. SECTION (DARK GREY)		
QTY.	3 NOS.		
LOCATION :	SHOP 02 (G/F)		
ELEVATION (VIEWED FROM THE OUTSIDE)			
SECTION :	65mm ALUM. SECTION (DARK GREY)		
QTY.	1 NOS.		
LOCATION :	SHOP 01 (G/F)		
ELEVATION (VIEWED FROM THE OUTSIDE)			
SECTION :	65mm ALUM. SECTION (DARK GREY)		
QTY.	1 NOS.		
LOCATION :	SHOP 02 (G/F)		
REMARK :	3mm THK ALUM. PLATE BACKING AND CUT-OUT OPENINGS VIA AIR DUCTS TO BE PROVIDED (NOTE: EXACT LOCATIONS REFER TO M.Y.A.C. SHOP DWGS.)		

BLD. REF :
 F.S.D. REF :
 Make:
 1. All dimensions are in mm.
 2. All elevations are viewed from outside.
 3. All dimensions to be verified on site before fabrication.
GENERAL NOTES

- Legend :**
 1. FFL --- Finished floor level
 2. SFL --- Structural floor level
 3. GR --- Ground level
 X11 --- DETAIL WORK NO.
 X001 --- REFER SHEET NO.

ARCHITECT :
MAK P L
 MAK P L ARCHITECTS
 ARCHITECTS (PRIVATE) LIMITED REGD.
 STRUCTURAL ENGINEER :
CMA
 C M YONG & ASSOCIATES LTD
 CIVIL ENGINEERS
 MAIN CONTRACTOR :
裕民建築有限公司
 YU MIN BUILDING CO., LTD.
 CLIENT :
MARBLE EDGE INVESTMENT LTD.

PRODUCT :
美特铝窗有限公司
 MITI Aluminium Window Fabricator Ltd.
 Unit 6-8, Sunny Industrial Centre, 1/F
 Block 6, Sunny Industrial Estate, 272727586
 Tel: (854) 2727586
 Fax: (854) 2727586
 PROPOSED RESIDENTIAL DEVELOPMENT AT NEW KOWLOON INLAND LOT, NOS 852

TITLE :
 LOWER SCHEDULE FOR IN-SITU ALUM. WINDOW
 JOB NO. : J-857
 DRAWN BY : AN DATE : 18.03.2021
 CHECK BY : SCWF AS: 1:30
 DWG. NO. : J857-AN-2014 REV : -

LOUVER MARK			
ELEVATION (VIEWED FROM THE OUTSIDE)			
SECTION :			
QTY.			
LOCATION :			
PLATE :			
REMARK :			

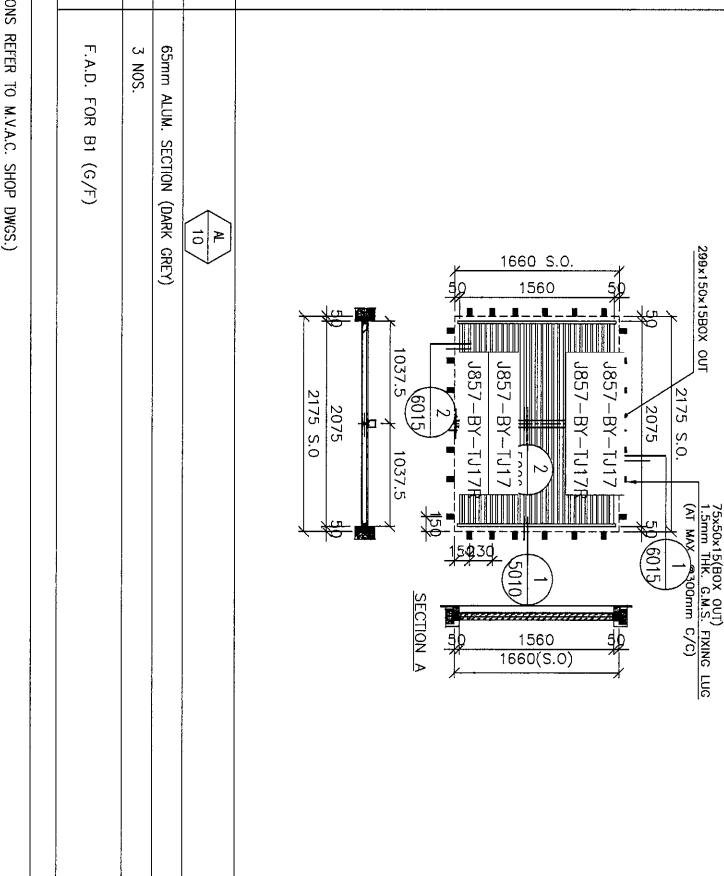
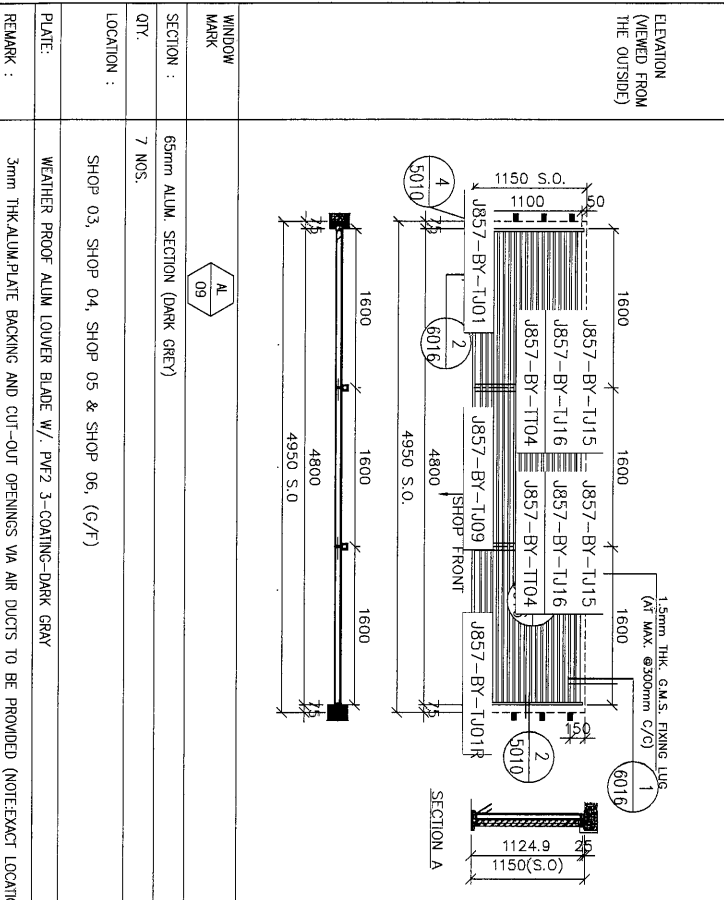
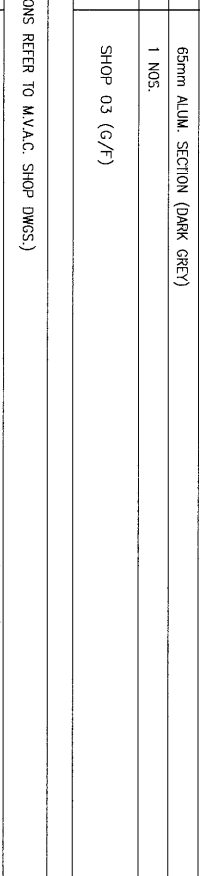
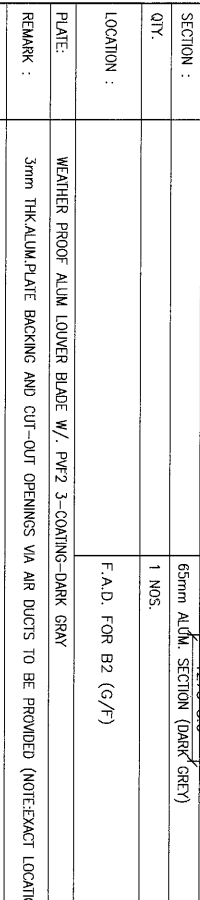
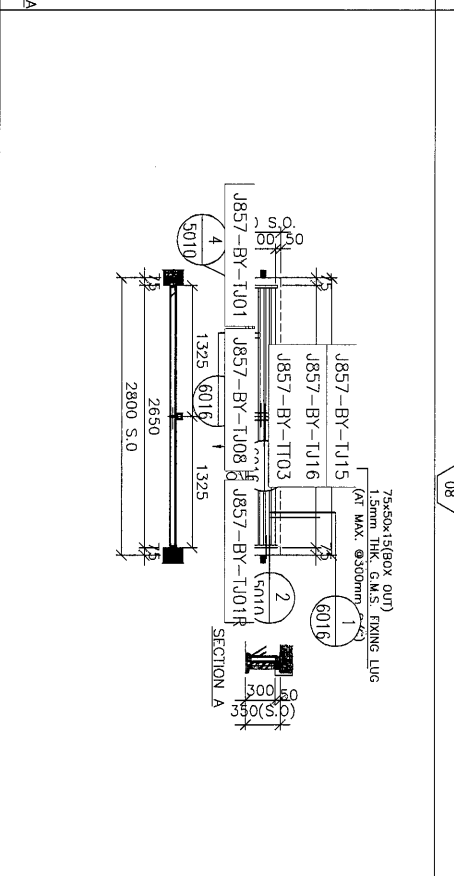
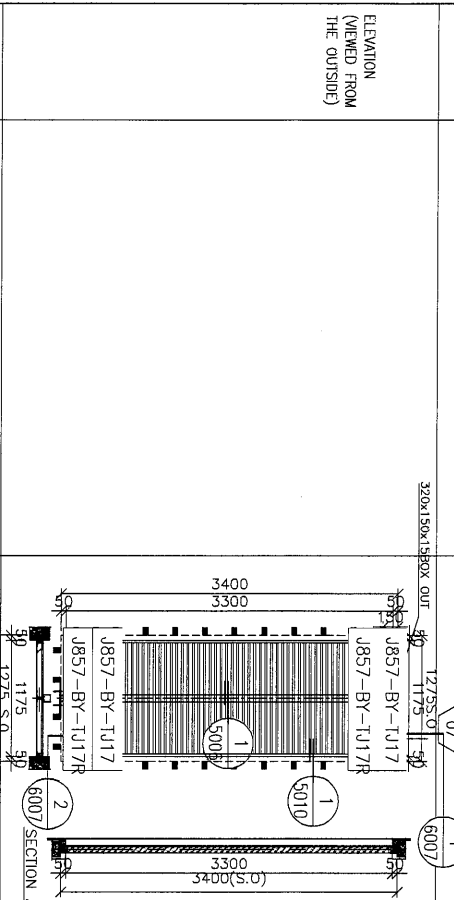

1. All dimensions are in mm.
 2. All dimensions are viewed from outside.
 3. All dimensions to be verified on site before fabrication.
 GENERAL NOTES

Legend:
 1. FTL - Finished Floor Level
 2. SFL - Standard Floor Level
 3. RL - Revised Detail

REVISION NO. X001
 REVISION SHEET NO. X001

ARCHITECT : M&A PARTNERS
 ARCHITECT (FRANCE) INTERIOR DESIGNERS

STRUCTURAL ENGINEER : CHAN YONG & ASSOCIATES LTD

MAIN CONTRACTOR : 裕民建築有限公司





PROJECT : 美特鋁質有限公司
 MIDU Aluminium Expansion Tank
 Unit 6-B, Sunny Industrial Centre, 1/F
 510, Cheong Chee Ling Road, Yuen Long
 New Territories, Hong Kong
 Tel: (852) 2711 1111 Fax: (852) 2711 9988

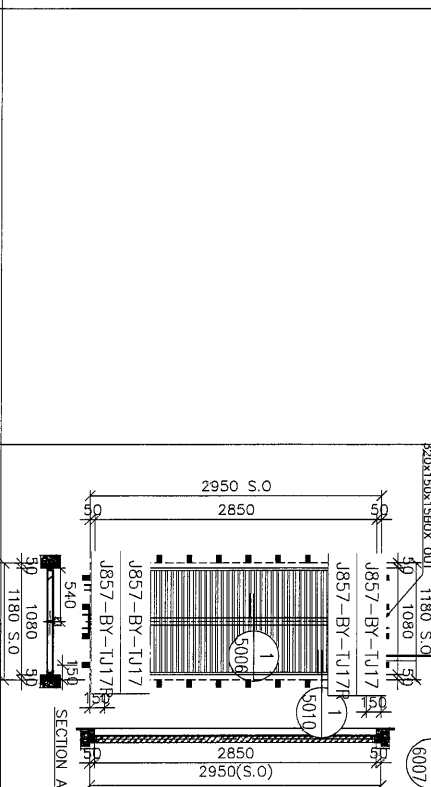
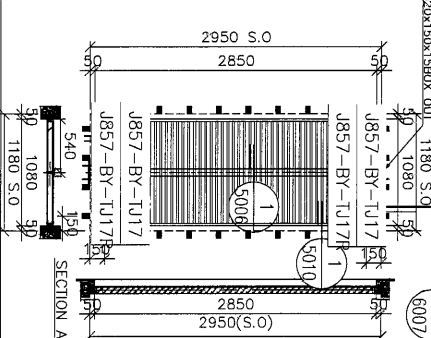
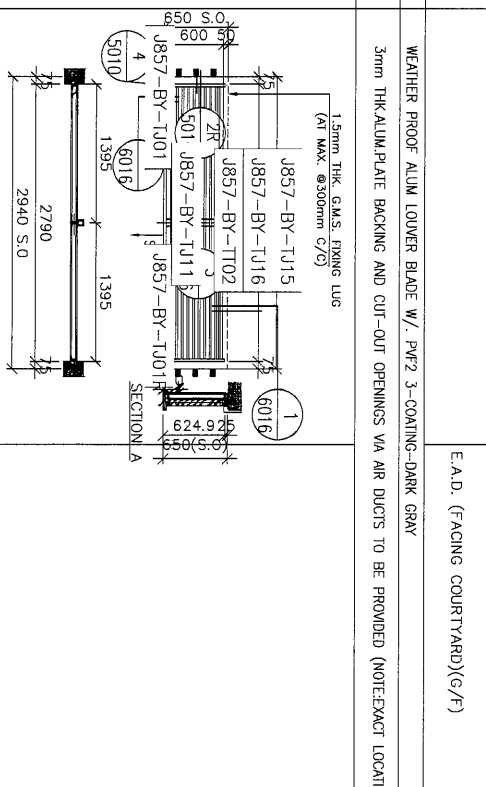

PROPOSED RESIDENTIAL DEVELOPMENT AT NEWKOWLOON INLAND LOT NO.55852

TITLE : LOUVER SCHEDULE FOR IN-SITU ALUM. WINDOW

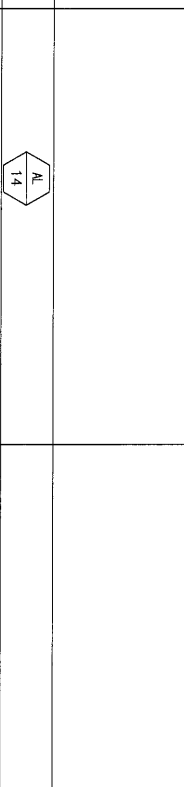
JOB NO. : J-857
 DRAWN BY : AN
 DATE : 18.07.2021
 CHECK BY : SCALE: A1:
 DATE: 18.07.2021

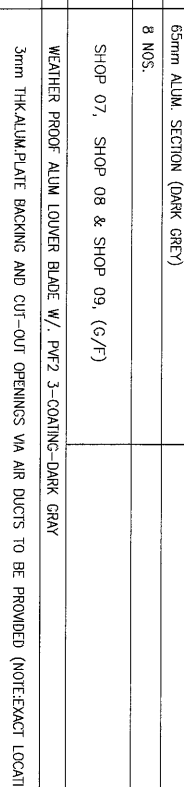
DWG. NO. : J857-INT-2015

LOWER MARK 		320x150x150x OUT 
ELEVATION (VIEWED FROM THE OUTSIDE) SECTION : QTY : LOCATION : PLATE : REMARK :	65mm ALUM. SECTION (DARK GREY) 1 NOS. E.A.D. (FRACING COURTYARD)(G/F)	65mm ALUM. SECTION (DARK GREY) 1 NOS. SHOP 06 (G/F)
ELEVATION (VIEWED FROM THE OUTSIDE) SECTION : QTY : LOCATION : PLATE : REMARK :	15mm THK. G.M.S. FIXING LUG (AT MAX. @300mm C/C) 	65mm ALUM. SECTION (DARK GREY) 1 NOS. F.A.D. FOR B2 (G/F)
WINDOW MARK 		65mm ALUM. SECTION (DARK GREY) 1 NOS. F.A.D. FOR B2 (G/F)
WINDOW MARK 		65mm ALUM. SECTION (DARK GREY) 1 NOS. F.A.D. FOR B2 (G/F)

B.O. REF : F.S.O. REF : MARK : 1. All dimensions are in mm. 2. All elevations are viewed from outside. 3. All dimensions to be verified on site before construction. GENERAL NOTES Legend : 1. FFL --- Finished Floor Level 2. SFL --- Structural floor level 3. RL --- Revised Level (X1) --- DETAIL MARK NO. (X001) --- REFER SHEET NO.	ARCHITECT :  ARCHITECT PARTNERS LIMITED STRUCTURAL ENGINEER :  CMA CHAMWONG & ASSOCIATES LTD MAIN CONTRACTOR : 裕民建築有限公司  MIDI MIDORI AUTOMATION MANUFACTURE LTD. Unit 6-8, Sunny Industrial Centre, 1/F 610 Shek Kwan Eng Road, Shek Kwan Industrial Estate, Tsing Yi, Kowloon Tel: (852) 2727 8986 Fax: (852) 2727 8986 PROJECT : PROPOSED RESIDENTIAL DEVELOPMENT AT NEW KOWLOON INLAND LOT NO.5582 TITLE : LOADS SCHEDULE FOR IN-SITU ALUM. WINDOW JOB NO. : J-657 DRAWN BY : AN DATE : 18.01.2021 CHECK BY : SWE AI DATE : 18.01.2021 DWG. NO. : J857-14-2016 REV. : --
--	---

LOUVER MARK	AL 53	AL 54	AL 61
-------------	-------	-------	-------

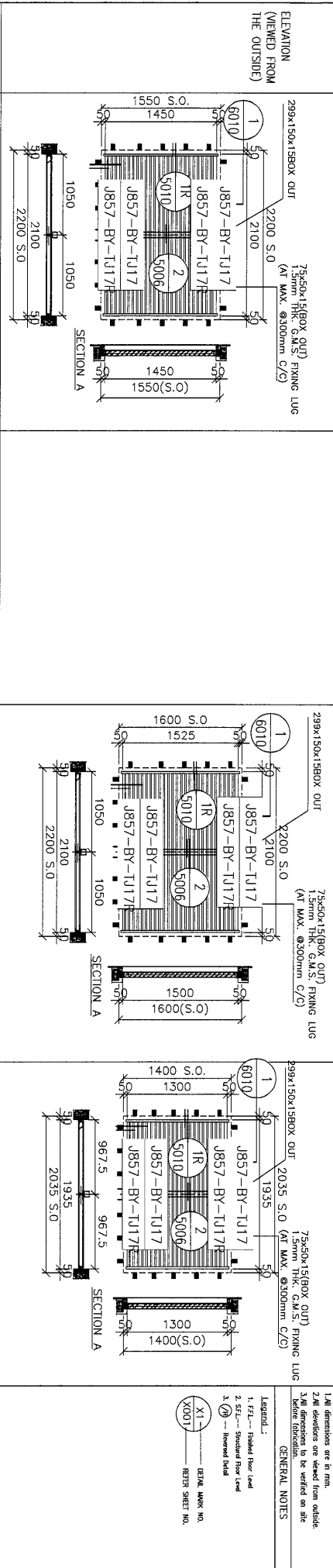

SECTION :	65mm ALUM. SECTION (DARK GREY)	65mm ALUM. SECTION (DARK GREY)	65mm ALUM. SECTION (DARK GREY)
QTY.	1 NOS.	2 NOS.	1 NOS.

LOCATION : EXHAUST AIR DUCT FOR E/M ROOM(1/F LIFT LOBBY)

EXHAUST AIR DUCT FOR FILTRATION PLANT RM(1/F)

EXHAUST AIR DUCT FOR E/M ROOM (1/F MANAGEMENT'S ACCESSIBLE TOILET)

PLATE: WEATHER PROOF ALUM LOWER BLADE W./ PVF2 3-COATING-DARK GRAY

WEATHER PROOF ALUM LOWER BLADE W./ PVF2 3-COATING-DARK GRAY

WEATHER PROOF ALUM LOWER BLADE W./ PVF2 3-COATING-DARK GRAY

REMARK : 3mm THK.ALUM.PLATE BACKING AND CUT-OUT OPENINGS VA AIR DUCTS TO BE PROVIDED (NOTE:EXACT LOCATIONS REFER TO M.V.A.C. SHOP DWGS.)

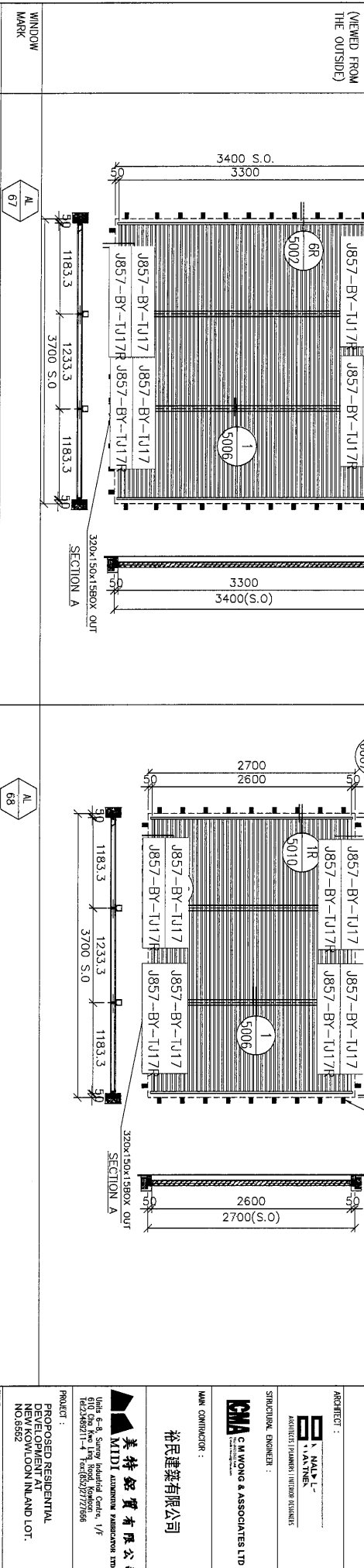

SECTION :	65mm ALUM. SECTION (DARK GREY)	65mm ALUM. SECTION (DARK GREY)
QTY.	1 NOS.	1 NOS.

LOCATION : EXHAUST AIR DUCT FOR WATER PUMP ROOM(2/F)

EXHAUST AIR DUCT FOR TBE (3/F)

PLATE: WEATHER PROOF ALUM LOWER BLADE W./ PVF2 3-COATING-DARK GRAY

WEATHER PROOF ALUM LOWER BLADE W./ PVF2 3-COATING-DARK GRAY

REMARK : 3mm THK.ALUM.PLATE BACKING AND CUT-OUT OPENINGS VA AIR DUCTS TO BE PROVIDED (NOTE:EXACT LOCATIONS REFER TO M.V.A.C. SHOP DWGS.)

BD. REF :
F.S.D. REF :
Mks :
1. All dimensions are in mm.
2. All dimensions are viewed from outside.
3. All dimensions to be verified on site before fabrication to avoid any error.
GENERAL NOTES

Legend :
1. FFL - Finished floor level
2. SFL - Standard floor level
3. RL - Proposed Level

X1 - REVISION NO.
X001 - REVISION SHEET NO.

NO.	DATE	GENERAL REMARK	BY
1	10/02/2022	REVISION	

CLIENT : MARBLE EDGE INVESTMENT LTD.

ARCHITECT : M&P ARCHITECTS
ARCHITECT (PLANNING) LICENSE NO. 117885
STRUCTURAL ENGINEER : CHONG & ASSOCIATES LTD.

MAIN CONTRACTOR : 裕民建築有限公司
美特鋁質有限公司
MIDI ALUMINIUM MANUFACTURER LTD.
Unit 6-B, Sunny Industrial Centre, 1/F
510 Cheong Chee Leng Street, Singapore
Tel: 65 6355 1111 Fax: 65 6355 7186

PROJECT : PROPOSED RESIDENTIAL DEVELOPMENT AT NEWKOWLOON INLAND LOT. NO.8552

TITLE : LOUVER SCHEDULE FOR IN-SITU ALUM. WINDOW

JOB NO. :	J-857
DRAWN BY :	AN
DATE :	10/FEB/2022
SCALE :	A1:100
CHKD BY :	AN
DWG. NO. :	J857-WV-2031