

工程指示 / 要求簡箋(E.I.)

工程指示編號：EI / 4076 / 21 修改版次：-
 工程編號 : J857 工程名稱 : 啟德 6552
 工程項目 : 幕牆單元件 - 繪畫模圖
 收件人 : Maggie Lor (羅小姐) 發件人 : Yancy Chen 日期 : 25/11/2021

要求提供 / 確認 事項：

- | | | |
|------------------------------------|-------------------------------------|-------------------------------|
| <input type="checkbox"/> 初步鋁料 B.M. | <input type="checkbox"/> 加工拆圖，然後生產 | <input type="checkbox"/> 尺寸表 |
| <input type="checkbox"/> 正式鋁料 B.M. | <input type="checkbox"/> 技術上資料 / 指示 | <input type="checkbox"/> 報價 |
| <input type="checkbox"/> 配件 B.M. | <input type="checkbox"/> 樣辦或貨品說明書 | <input type="checkbox"/> 分判合約 |
| <input type="checkbox"/> 其他：_____ | | |

內容：

請安排按附件繪畫模圖. 共 71 頁.

CAD 圖見 U:\to hk\maggie\J857\EI\4076\

請在 30/11/2021 前完成上列要求。

附：

1+ 71 頁

以上項目為：

- 原合約工程包 原合約工程加 / 減賬 新工程報價

原因：-

分發東莞各部門：

- () 生產技術總監 連附件 () 技術部 連附件 () 生產部 連附件 () 機械設計部 連附件
 () 採購部 連附件 (/) 生產統籌部 連附件
 (/) 質檢部 連附件 () 會計部 連附件 () 報關組 連附件 () 其他 _____ 連附件

分發香港各部門：

- () 行政部 連附件 () 會計部 連附件 () 統籌部 連附件 () 工程部地盤科文 連附件
 () 採購部 連附件 () QS 部 連附件 () 維修部 連附件 () 其他 _____ 連附件

傳遞編號：

HK 2148 / 21

發件人簽署：

項目經理簽署：

CUSTOMER		CUSTOMER APPROVAL	CUST PART NO.	AL03A
			SECTION NO.	X86048

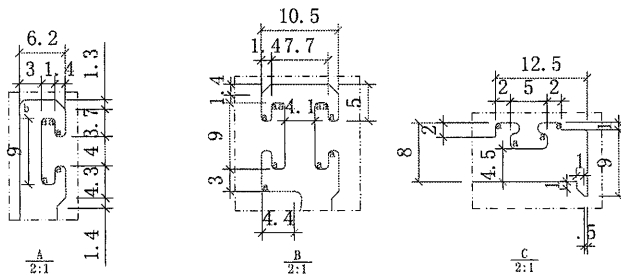
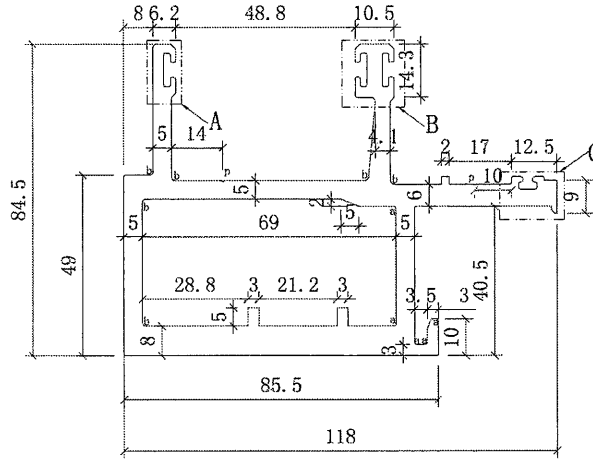

美特鋁質有限公司	
承認圖面	<i>[Signature]</i>
日期	25/11

p=R0.3X0.3
a=R 0.5 b=R 1

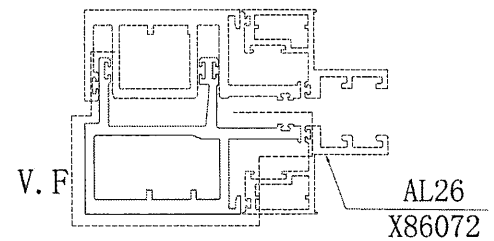

SIGNATURE GRADEING	HIGH SIGNATURE GRADEING	C. C. DIA (MM)		PERIMETER (MM)	796.1	STANDARD		SCALE	1:1
AREA (SQ MM)	2119.4	UNSPECIFIED THICKNESS	--	SURFACE AREA	317	ALLOY	6063-T6	VERSION	
MASS (KG/M)	5.743	UNSPECIFIED CORNERS	R=0.3						
COMPANY ISSUE		DRAWN	AN	DATE	21-11-24	APPELLATION	-	PAGE OF	
		STANDARDIZATION		DATE					
		TO SIGN		DATE					
		AUDITING		DATE					
MARKER	MODIFY FILE NO	SIGNATURE	DATE	APPROV	DATE				

CUSTOMER		CUSTOMER APPROVAL		CUST PART NO.	AL04
				SECTION NO.	X86049

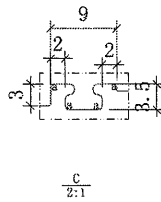
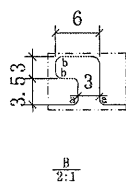
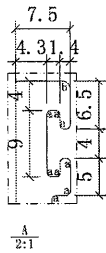
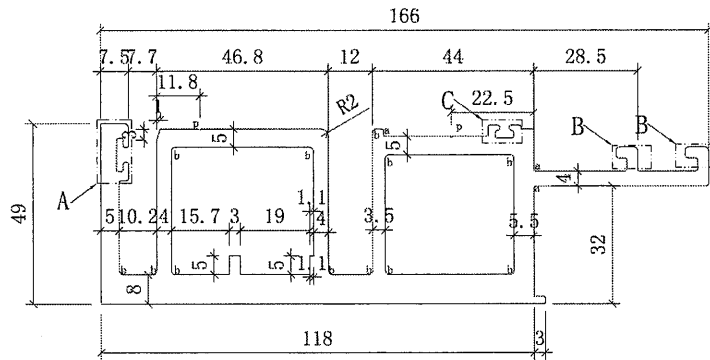

美特鋁質有限公司	
承認圖面	<i>[Signature]</i>
日期	25/11

p=R0.3X0.3
a=R 0.5 b=R 1

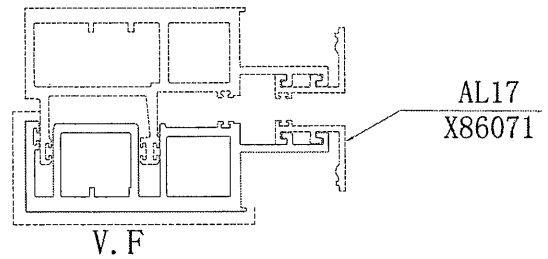

SIGNATURE GRADEING	HIGH SIGNATURE GRADEING	C. C. DIA (MM)						
AREA (SQ MM)	2489.5	UNSPECIFIED THICKNESS	--	PERIMETER (MM)	947.3	STANDARD		SCALE 1:1
MASS (KG/M)	6.747	UNSPECIFIED CORNERS	R=0.3	SURFACE AREA	182	ALLOY	6063-T6	VERSION
COMPANY ISSUE			DRAWN	AN	DATE	21-11-24	APELLATION	-
			STANDARDIZATION		DATE			PAGE OF
			TO SIGN		DATE			
			AUDITING		DATE			
MARKER	MODIFY	FILE NO	SIGNATURE	DATE	APPROV			

美特鋁質有限公司
MIDI Aluminium Fabricator Ltd.

CUSTOMER	CUSTOMER APPROVAL	CUST PART NO.	AL04A
		SECTION NO.	X86050

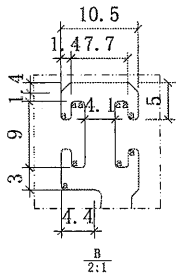
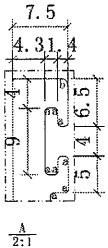
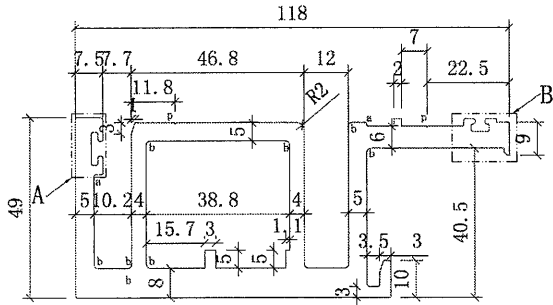

美特鋁質有限公司	
承認圖面	<i>[Signature]</i>
日期	25/11

p=R0.3X0.3
a=R 0.5 b=R 1

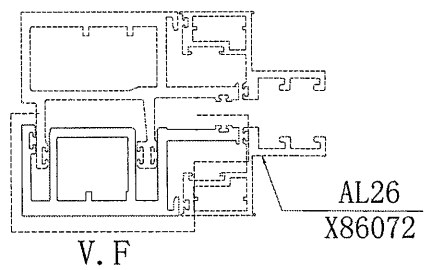

SIGNATURE GRADEING	HIGH SIGNATURE GRADEING	C. C. DIA (MM)		PERIMETER (MM)	703.7	STANDARD		SCALE	1:1	
AREA (SQ MM)	1867.4	UNSPECIFIED THICKNESS	--	SURFACE AREA	275	ALLOY	6063-T6	VERSION		
MASS (KG/M)	5.060	UNSPECIFIED CORNERS	R=0.3	DATE	21-11-24	APELLATION	-	PAGE	OF	
COMPANY ISSUE			DRAWN	AN	DATE	21-11-24	APELLATION	-	PAGE	OF
			STANDARDIZATION		DATE		 美特鋁質有限公司 MIDI Aluminium Fabricator Ltd.			
			TO SIGN		DATE					
			AUDITING		DATE					
MARKER	MODIFY	FILE NO	SIGNATURE	DATE	APPROV	DATE				

CUSTOMER	CUSTOMER APPROVAL	CUST PART NO.	AL07
		SECTION NO.	X86051

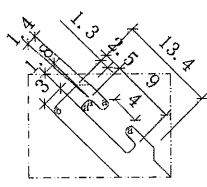
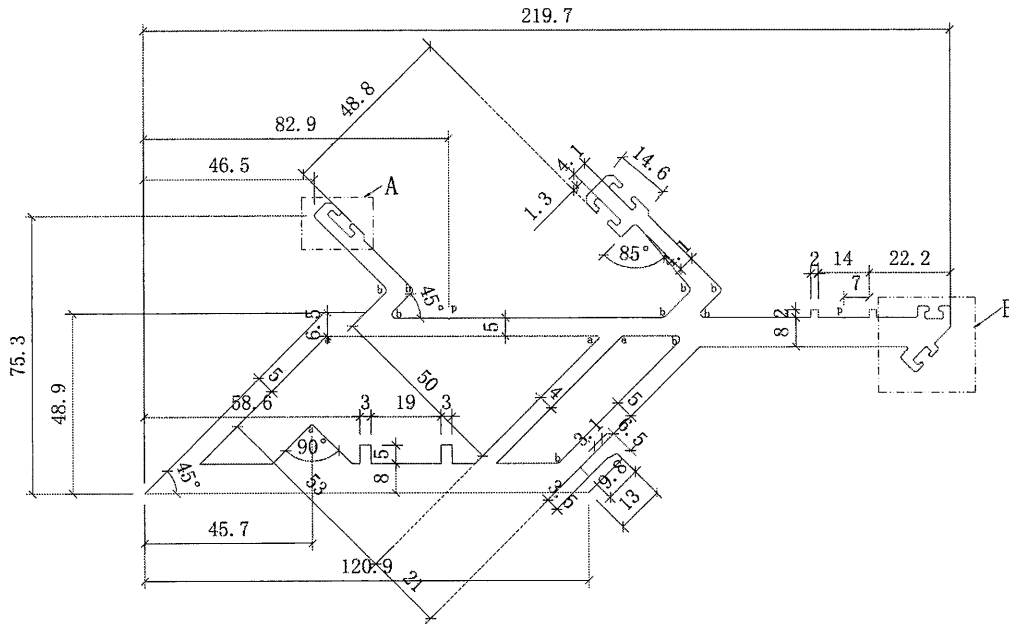

A
2:1

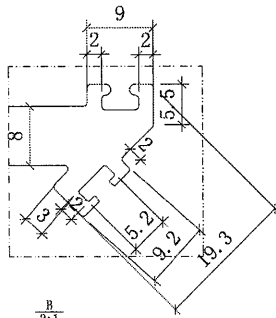

B
2:1

美特鋁質有限公司	
承認圖面	<i>[Signature]</i>
日期	25/11

p=R0.3X0.3

a=R 0.5 b=R 1

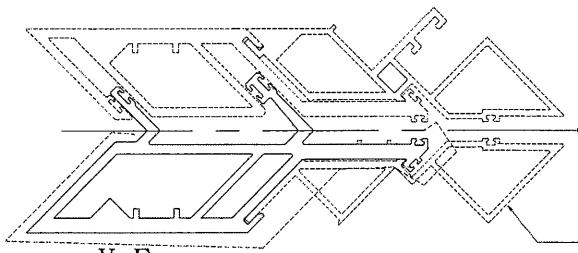

V.F

AL39
X86076

SIGNATURE GRADEING	HIGH SIGNATURE GRADEING	C. C. DIA (MM)							
AREA (SQ MM)	3435.1	UNSPECIFIED THICKNESS	--	PERIMETER (MM)	1178.5	STANDARD		SCALE	1:1
MASS (KG/M)	9.309	UNSPECIFIED CORNERS	R=0.3	SURFACE AREA	405	ALLOY	6063-T6	VERSION	
COMPANY ISSUE			DRAWN	AN	DATE	21-11-24	APELLATION	-	PAGE OF
			STANDARDIZATION		DATE				
			TO SIGN		DATE				
			AUDITING		DATE				
MARKER	MODIFY	FILE NO	SIGNATURE	DATE	APPROV				

美特鋁質有限公司
MIDI Aluminium Fabricator Ltd.

CUSTOMER		CUSTOMER APPROVAL		CUST PART NO.	AL85
				SECTION NO.	X86054

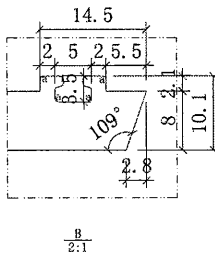
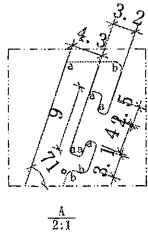
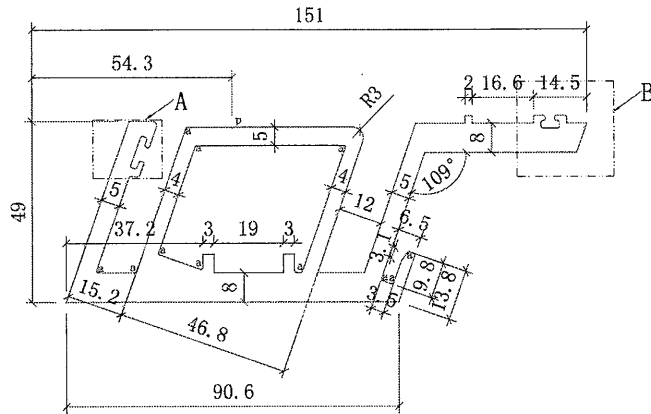

美特鋁質有限公司	
承認圖面	<i>[Signature]</i>
日期	25/11

p=R0.3X0.3
a=R 0.5 b=R 1

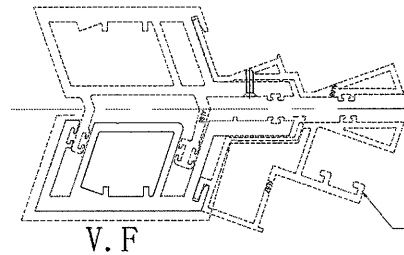

AL87
X86088

SIGNATURE GRADEING	HIGH SIGNATURE GRADEING	C. C. DIA (MM)							
AREA (SQ MM)	2123.4	UNSPECIFIED THICKNESS	--	PERIMETER (MM)	748.8	STANDARD		SCALE	1:1
MASS (KG/M)	5.754	UNSPECIFIED CORNERS	R=0.3	SURFACE AREA	293	ALLOY	6063-T6	VERSION	
COMPANY ISSUE			DRAWN	AN	DATE	21-11-24	APELLATION	-	PAGE OF
			STANDARDIZATION		DATE				
			TO SIGN		DATE				
			AUDITING		DATE				
MARKER	MODIFY	FILE NO	SIGNATURE	DATE	APPROV				

美特鋁質有限公司
MIDI Aluminium Fabricator Ltd.

CUSTOMER	CUSTOMER APPROVAL	CUST PART NO.	AL67
		SECTION NO.	X86057

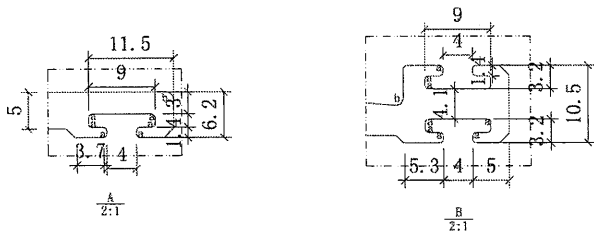
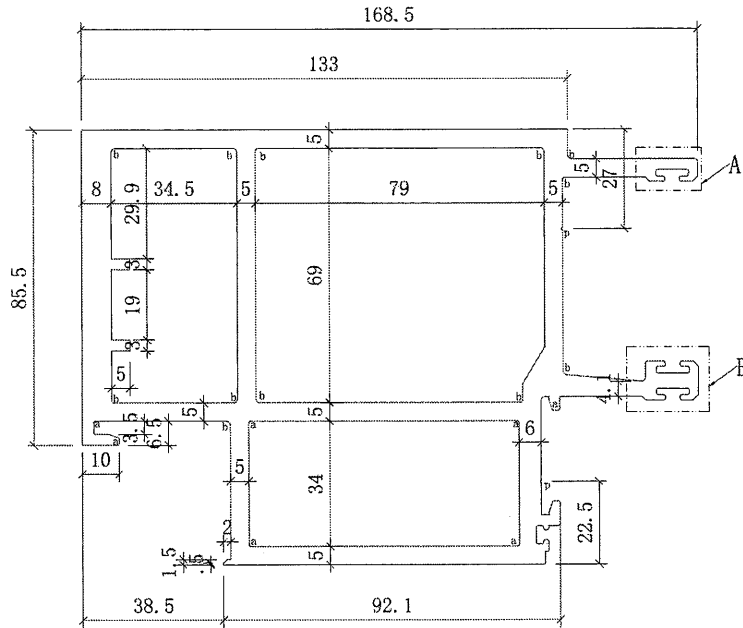

美特鋁質有限公司	
承認圖面	<i>[Signature]</i>
日期	25/11

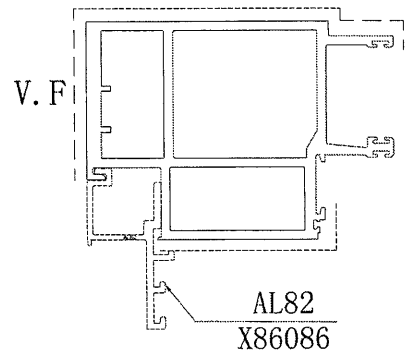

p=R0.3X0.3
a=R 0.5 b=R 1

SIGNATURE GRADEING	HIGH SIGNATURE GRADEING	C. C. DIA (MM)		PERIMETER (MM)	1489.4	STANDARD		SCALE	1:1
AREA (SQ MM)	3899.5	UNSPECIFIED THICKNESS	--	SURFACE AREA	380	ALLOY	6063-T6	VERSION	
MASS (KG/M)	10.569	UNSPECIFIED CORNERS	R=0.3	DATE	21-11-24	APELLATION	-	PAGE	OF
COMPANY ISSUE			DRAWN	AN	DATE				
			STANDARDIZATION		DATE				
			TO SIGN		DATE				
			AUDITING		DATE				
MARKER	MODIFY	FILE NO	SIGNATURE	DATE	APPROV				

 美特鋁質有限公司
MIDI Aluminium Fabricator Ltd.

CUSTOMER		CUSTOMER APPROVAL	CUST PART NO.	AL11
			SECTION NO.	X86059

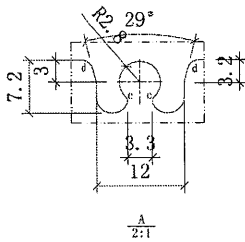
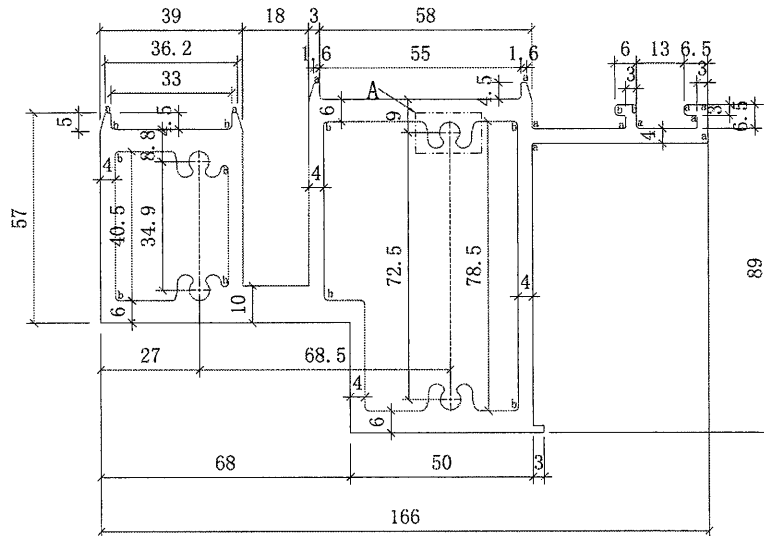

美特鋁質有限公司	
承認圖面	<i>[Signature]</i>
日期	25/11

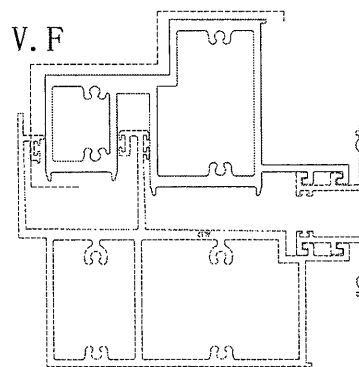

X86071
AL17

p=R0.3X0.3

a=R 0.5 b=R 1 c=R0.8 d=R1.6

SIGNATURE GRADEING	HIGH SIGNATURE GRADEING	C. C. DIA (MM)							
AREA (SQ MM)	2861.4	UNSPECIFIED THICKNESS	--	PERIMETER (MM)	1146.8	STANDARD		SCALE	1:1
MASS (KG/M)	7.753	UNSPECIFIED CORNERS	R=0.3	SURFACE AREA	219	ALLOY	6063-T6	VERSION	
COMPANY ISSUE			DRAWN	AN	DATE	21-11-24	APPELLATION	-	PAGE OF
			STANDARDIZATION		DATE				
			TO SIGN		DATE				
			AUDITING		DATE				
MARKER	MODIFY	FILE NO	SIGNATURE	DATE	APPROV	DATE			

CUSTOMER	CUSTOMER APPROVAL	CUST PART NO.	AL12
		SECTION NO.	X86060

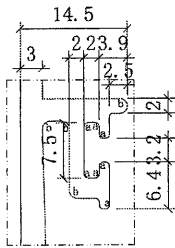
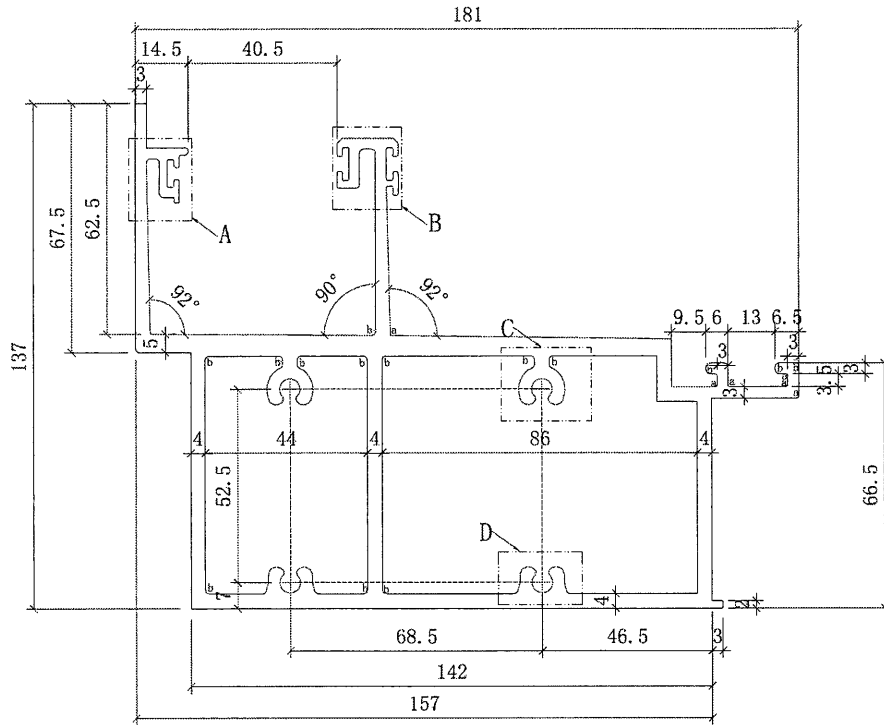

A
2:1

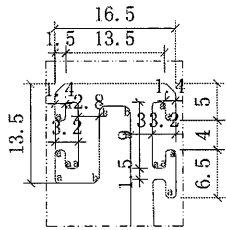

B
2:1

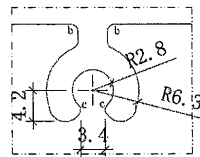

C
2:1

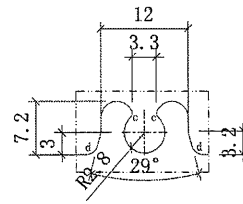

D
2:1

美特鋁質有限公司	
承認圖面	
日期	25/11

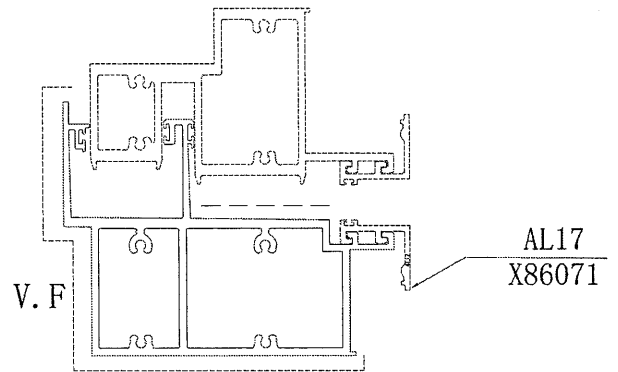

p=R0.3X0.3

a=R 0.5 b=R 1 c=R0.8 d=R1.6

SIGNATURE GRADEING	HIGH SIGNATURE GRADEING	C. C. DIA (MM)							
AREA (SQ MM)	3148.2	UNSPECIFIED THICKNESS	--	PERIMETER (MM)	1574.0	STANDARD		SCALE	1:1
MASS (KG/M)	8.531	UNSPECIFIED CORNERS	R=0.3	SURFACE AREA	377	ALLOY	6063-T6	VERSION	
COMPANY ISSUE			DRAWN	AN	DATE	21-11-24	APPELLATION	-	PAGE OF
			STANDARDIZATION		DATE				
			TO SIGN		DATE				
			AUDITING		DATE				
MARKER	MODIFY	FILE NO	SIGNATURE	DATE	APPROV				

美特鋁質有限公司
MIDI Aluminium Fabricator Ltd.

CUSTOMER	CUSTOMER APPROVAL	CUST PART NO.	AL70
		SECTION NO.	X86065

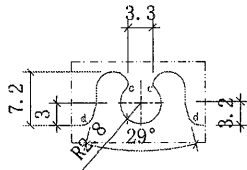
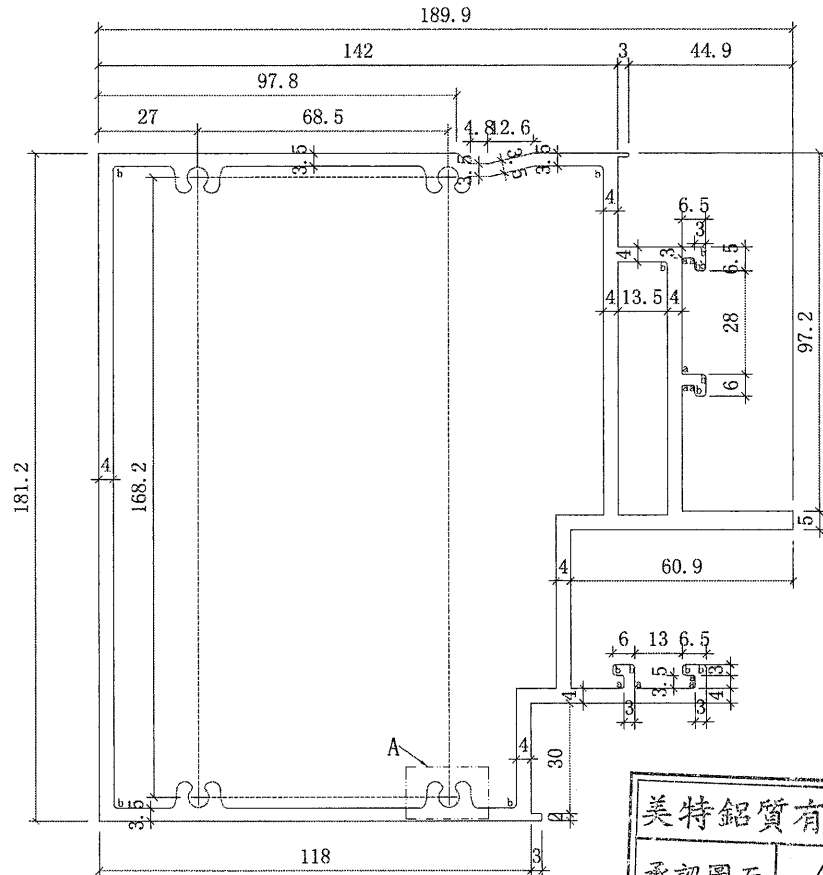

A
2:1

美特鋁質有限公司	
承認圖面	<i>[Signature]</i>
日期	25/11

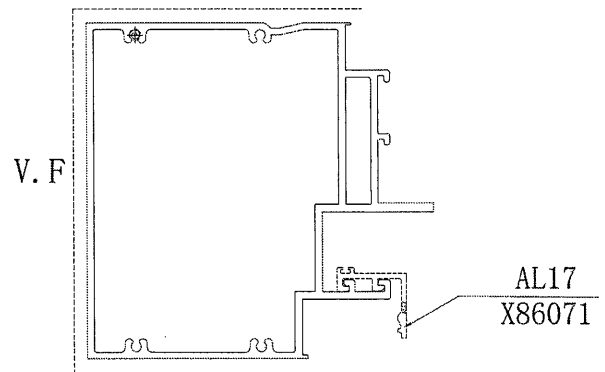

p=R0.3X0.3

a=R 0.5 b=R 1 c=R0.8 d=R1.6

SIGNATURE GRADEING	HIGH SIGNATURE GRADEING	C. C. DIA (MM)							
AREA (SQ MM)	3460.2	UNSPECIFIED THICKNESS	--	PERIMETER (MM)	1769.5	STANDARD		SCALE	1:1
MASS (KG/M)	9.377	UNSPECIFIED CORNERS	R=0.3	SURFACE AREA	457	ALLOY	6063-T6	VERSION	
COMPANY ISSUE			DRAWN	AN	DATE	21-11-24	APPELLATION	-	PAGE OF
			STANDARDIZATION		DATE				
			TO SIGN		DATE				
			AUDITING		DATE				
MARKER	MODIFY	FILE NO	SIGNATURE	DATE	APPROV				

美特鋁質有限公司
MIDI Aluminium Fabricator Ltd.

CUSTOMER	CUSTOMER APPROVAL	CUST PART NO.	AL71
		SECTION NO.	X86066

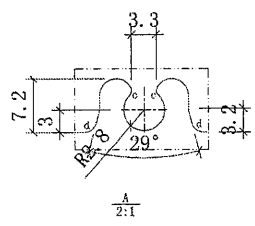
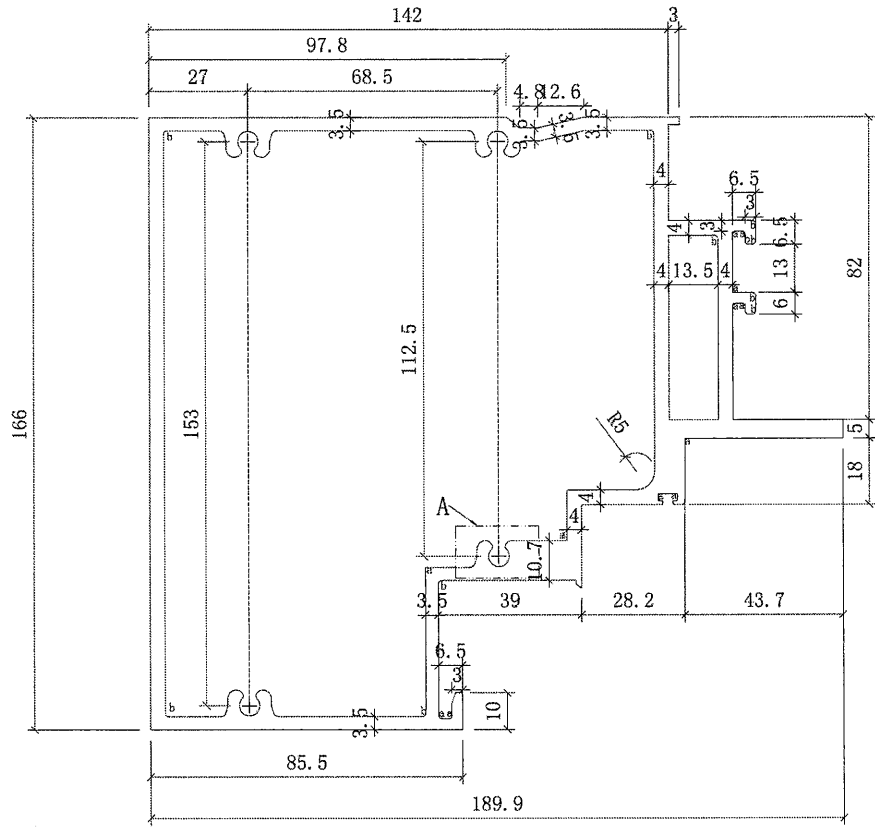

美特鋁質有限公司	
承認圖面	<i>[Signature]</i>
日期	25/11

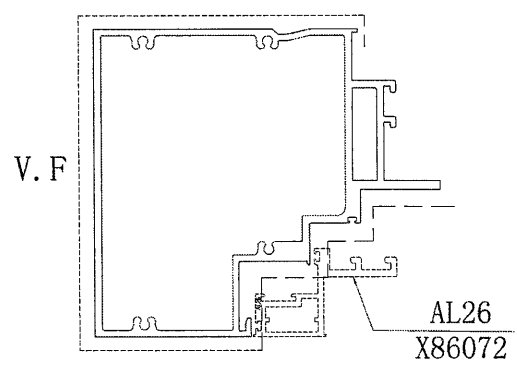

$p=R0.3 \times 0.3$
 $a=R 0.5 \quad b=R 1 \quad c=R0.8 \quad d=R1.6$

SIGNATURE GRADEING	HIGH SIGNATURE GRADEING	C. C. DIA (MM)			PERIMETER (MM)	1579.6	STANDARD	SCALE	1:1
AREA (SQ MM)	3249.6	UNSPECIFIED THICKNESS	--		SURFACE AREA	621	ALLOY	6063-T6	VERSION
MASS (KG/M)	8.806	UNSPECIFIED CORNERS	R=0.3		DATE	21-11-24	APELLATION	-	PAGE OF
COMPANY ISSUE				DRAWA	AN	DATE			
				STANDA-RDIZATION		DATE			
				TO SIGN		DATE			
				AUDITING		DATE			
MARKER	MODIFY	FILE NO	SIGNATURE	DATE	APPROV	DATE			

美特鋁質有限公司
 MIDI Aluminium Fabricator Ltd.

CUSTOMER	CUSTOMER APPROVAL	CUST PART NO.	AL107
		SECTION NO.	X86069

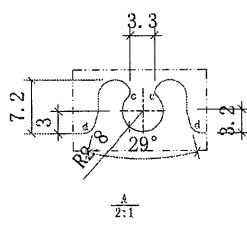
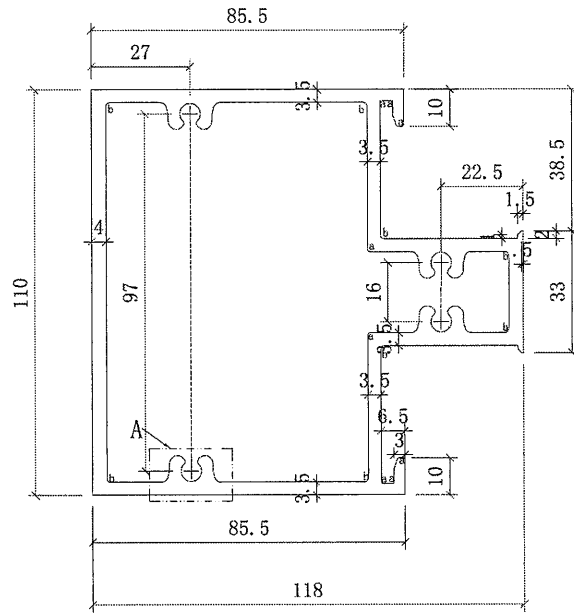

美特鋁質有限公司	
承認圖面	<i>[Signature]</i>
日期	25/11

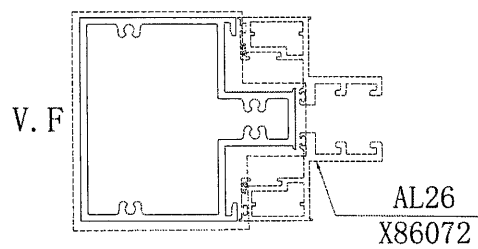

$p=R0.3 \times 0.3$
 $a=R 0.5 \quad b=R 1 \quad c=R0.8 \quad d=R1.6$

SIGNATURE GRADEING	HIGH SIGNATURE GRADEING	C. C. DIA (MM)							
AREA (SQ MM)	1918.2	UNSPECIFIED THICKNESS	--	PERIMETER (MM)	1029.0	STANDARD		SCALE	1:1
MASS (KG/M)	5.198	UNSPECIFIED CORNERS	R=0.3	SURFACE AREA	512	ALLOY	6063-T6	VERSION	
COMPANY ISSUE			DRAWN	AN	DATE	21-11-24	APPELLATION	-	PAGE OF
			STANDARDIZATION		DATE				
			TO SIGN		DATE				
			AUDITING		DATE				
MARKER	MODIFY	FILE NO	SIGNATURE	DATE	APPROV	DATE			

CUSTOMER	CUSTOMER APPROVAL	CUST PART NO.	AL38
		SECTION NO.	X86075

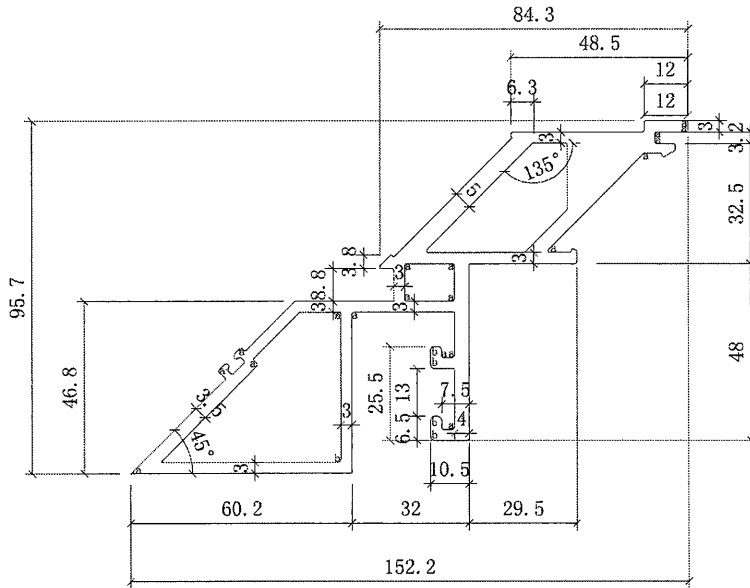

美特鋁質有限公司	
承認圖面	<i>[Signature]</i>
日期	20/11

p=R0.3X0.3
a=R 0.5 b=R 1

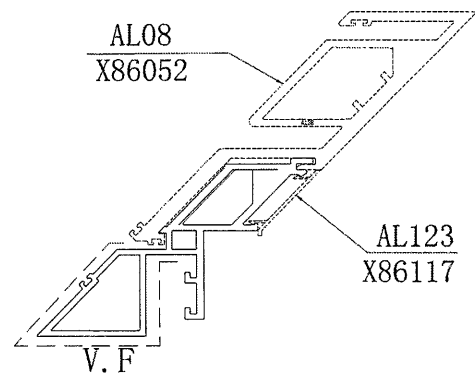

SIGNATURE GRADEING	HIGH SIGNATURE GRADEING	C. C. DIA (MM)							
AREA (SQ MM)	1791.2	UNSPECIFIED THICKNESS	---	PERIMETER (MM)	899.5	STANDARD		SCALE	1:1
MASS (KG/M)	4.854	UNSPECIFIED CORNERS	R=0.3	SURFACE AREA	208	ALLOY	6063-T6	VERSION	
COMPANY ISSUE			DRAWN	AN	DATE	21-11-24	APELLATION	-	PAGE OF
			STANDARDIZATION		DATE				
			TO SIGN		DATE				
			AUDITING		DATE				
MARKER	MODIFY	FILE NO	SIGNATURE	DATE	APPROV				

美特鋁質有限公司
MIDI Aluminium Fabricator Ltd.

CUSTOMER	CUSTOMER APPROVAL	CUST PART NO.	AL49
		SECTION NO.	X86078

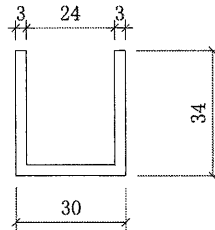

美特鋁質有限公司	
承認圖面	<i>[Signature]</i>
日期	25/11

p=R0.3X0.3

a=R 0.5 b=R 1

SIGNATURE GRADEING	HIGH SIGNATURE GRADEING	C. C. DIA (MM)							
AREA (SQ MM)	276	UNSPECIFIED THICKNESS	--	PERIMETER (MM)	190	STANDARD		SCALE	1:1
MASS (KG/M)	0.748	UNSPECIFIED CORNERS	R=0.3	SURFACE AREA	0	ALLOY	6063-T6	VERSION	
COMPANY ISSUE			DRAWN	AN	DATE	21-11-24	APPELLATION	-	PAGE OF
			STANDARDIZATION		DATE				
			TO SIGN		DATE				
			AUDITING		DATE				
MARKER	MODIFY	FILE NO	SIGNATURE	DATE	APPROV				

 美特鋁質有限公司
MIDI Aluminium Fabricator Ltd.

CUSTOMER	CUSTOMER APPROVAL	CUST PART NO.	AL58
		SECTION NO.	X86079

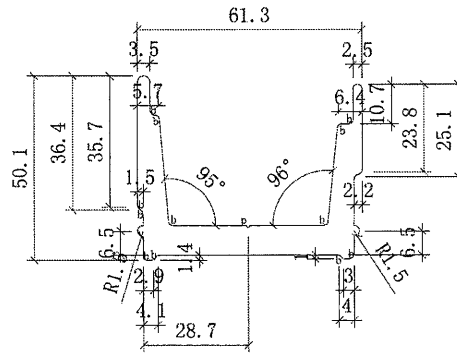

美特鋁質有限公司	
承認圖面	<i>[Signature]</i>
日期	25/11

p=R0.3X0.3
a=R 0.5 b=R 1

AL12
X86060

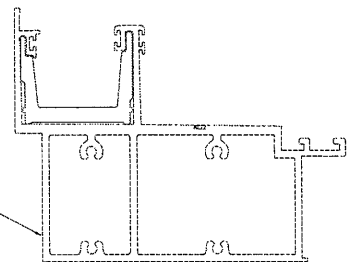

SIGNATURE GRADEING	HIGH SIGNATURE GRADEING	C. C. DIA (MM)							
AREA (SQ MM)	937.1	UNSPECIFIED THICKNESS	---	PERIMETER (MM)	290.8	STANDARD		SCALE	1:1
MASS (KG/M)	2.539	UNSPECIFIED CORNERS	R=0.3	SURFACE AREA	0	ALLOY	6061-T6	VERSION	
COMPANY ISSUE			DRAWN	AN	DATE	21-11-24	APPELLATION	-	PAGE OF
			STANDARDIZATION		DATE				
			TO SIGN		DATE				
			AUDITING		DATE				
MARKER	MODIFY	FILE NO	SIGNATURE	DATE	APPROV				

 美特鋁質有限公司
MIDI Aluminium Fabricator Ltd.

CUSTOMER	CUSTOMER APPROVAL	CUST PART NO.	AL77
		SECTION NO.	X86081

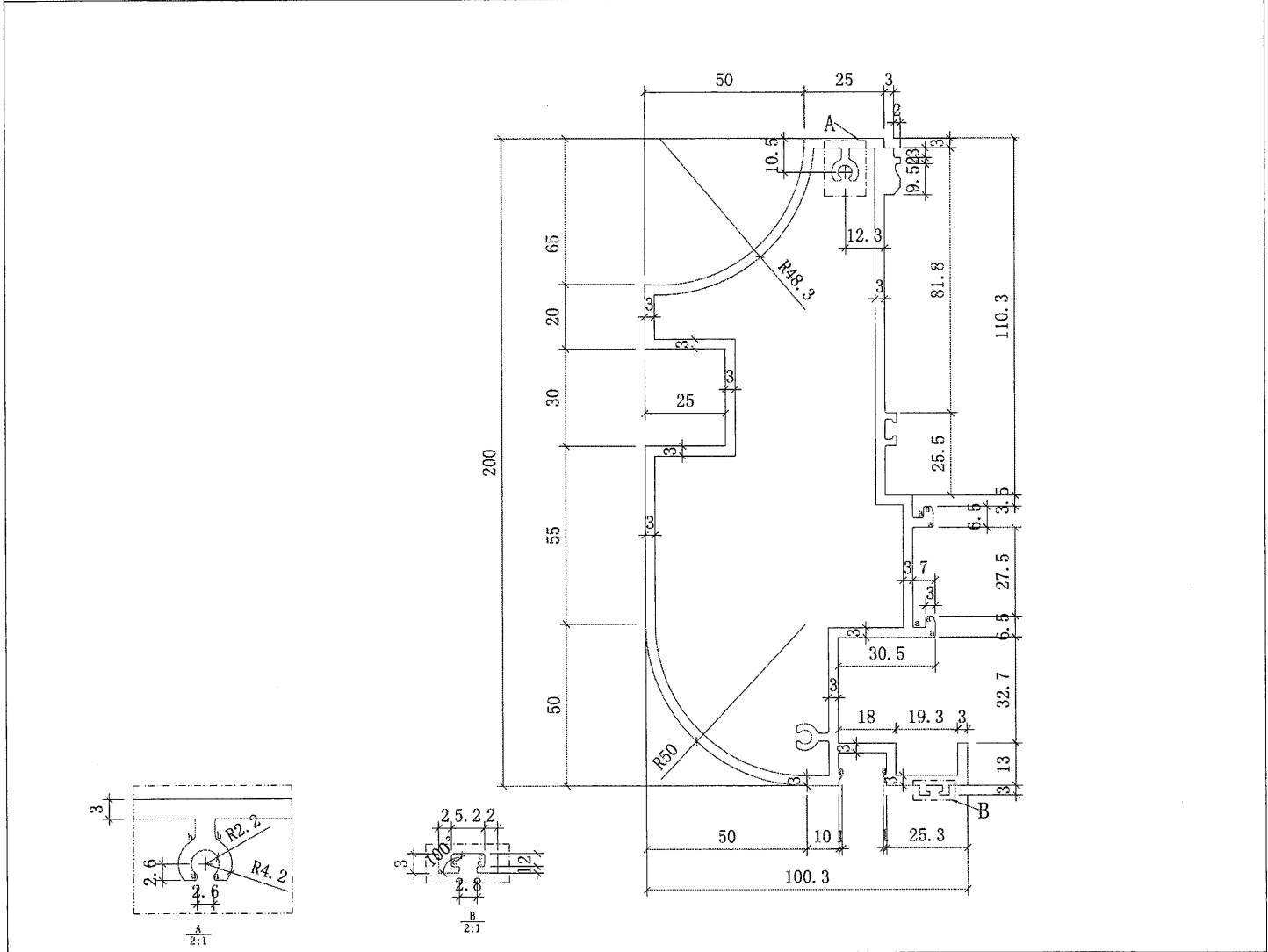

美特鋁質有限公司
承認圖面
日期 25/11

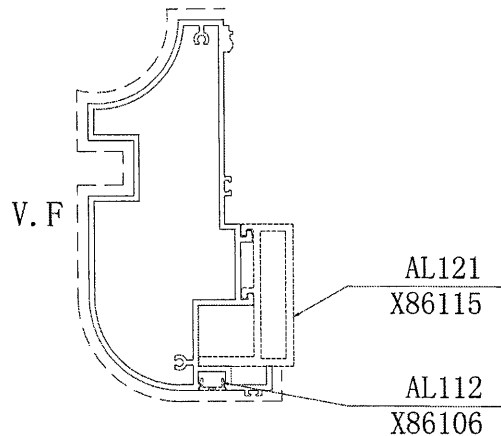

p=R0.3X0.3
a=R 0.5 b=R 1

SIGNATURE GRADEING	HIGH SIGNATURE GRADEING	C. C. DIA (MM)							
AREA (SQ MM)	2106.8	UNSPECIFIED THICKNESS	--	PERIMETER (MM)	1403.5	STANDARD		SCALE	1:1
MASS (KG/M)	5.709	UNSPECIFIED CORNERS	R=0.3	SURFACE AREA	420	ALLOY	6063-T5	VERSION	
COMPANY ISSUE			DRAWN	AN	DATE	21-11-24	APPELLATION	-	PAGE OF
			STANDARDIZATION		DATE				
			TO SIGN		DATE				
			AUDITING		DATE				
MARKER	MODIFY	FILE NO	SIGNATURE	DATE	APPROV		DATE		

美特鋁質有限公司
MIDI Aluminium Fabricator Ltd.

CUSTOMER	CUSTOMER APPROVAL	CUST PART NO.	AL78
		SECTION NO.	X86082

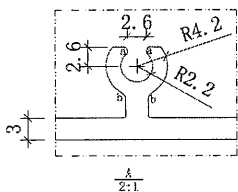
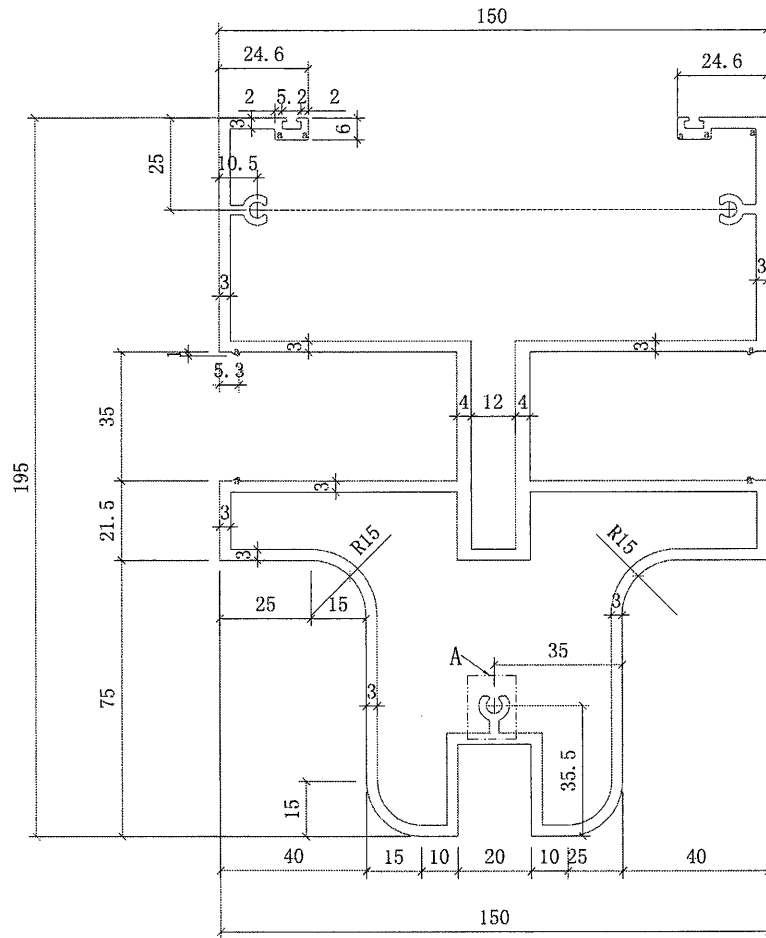

美特鋁質有限公司	
承認圖面	<i>[Signature]</i>
日期	25/11

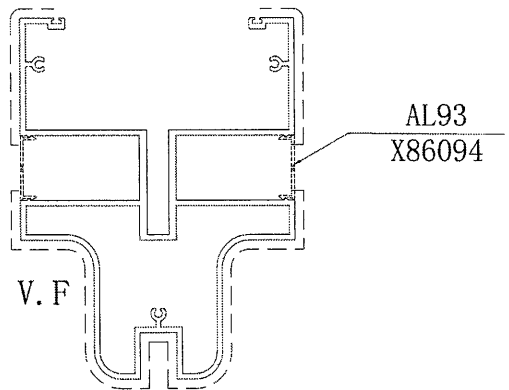

p=R0.3X0.3
a=R 0.5 b=R 1

SIGNATURE GRADEING	HIGH SIGNATURE GRADEING	C. C. DIA (MM)							
AREA (SQ MM)	3003.4	UNSPECIFIED THICKNESS	--	PERIMETER (MM)	1967.1	STANDARD		SCALE	1:1
MASS (KG/M)	8.138	UNSPECIFIED CORNERS	R=0.3	SURFACE AREA	575	ALLOY	6063-T5	VERSION	
COMPANY ISSUE			DRAWN	AN	DATE	21-11-24	APPELLATION	-	PAGE OF
			STANDARDIZATION		DATE				
			TO SIGN		DATE				
			AUDITING		DATE				
MARKER	MODIFY	FILE NO	SIGNATURE	DATE	APPROV				

美特鋁質有限公司
MIDI Aluminium Fabricator Ltd.

CUSTOMER		CUSTOMER APPROVAL		CUST PART NO.	AL79
				SECTION NO.	X86083

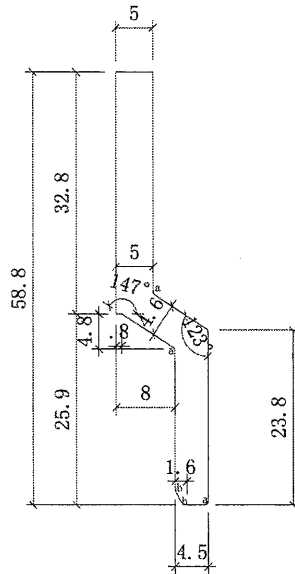

2:1

美特鋁質有限公司	
承認圖面	<i>[Signature]</i>
日期	25/11

p=R0.3X0.3

a=R 0.5 b=R 1

SIGNATURE GRADEING	HIGH SIGNATURE GRADEING	C. C. DIA (MM)							
AREA (SQ MM)	299	UNSPECIFIED THICKNESS	--	PERIMETER (MM)	134.5	STANDARD		SCALE	1:1
MASS (KG/M)	0.810	UNSPECIFIED CORNERS	R=0.3	SURFACE AREA	0	ALLOY	6063-T6	VERSION	
COMPANY ISSUE			DRAWA	AN	DATE	21-11-24	APELLATION	-	PAGE OF
			STANDA-		DATE				
			RDIZATION		DATE				
			TO SIGN		DATE				
			AUDITING		DATE				
MARKER	MODIFY	FILE NO	SIGNATURE	DATE	APPROV				

 美特鋁質有限公司
MIDI Aluminium Fabricator Ltd.

CUSTOMER	CUSTOMER APPROVAL	CUST PART NO.	AL80
		SECTION NO.	X86084

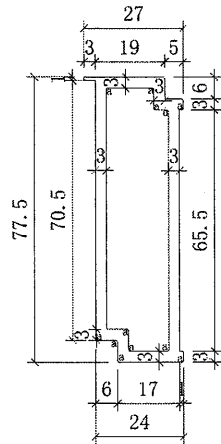

美特鋁質有限公司	
承認圖面	<i>[Signature]</i>
日期	25/11

AL11
X86059

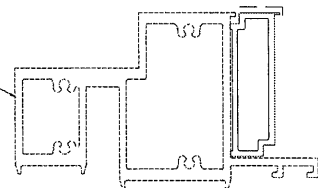

p=R0.3X0.3

a=R 0.5 b=R 1

SIGNATURE GRADEING	HIGH SIGNATURE GRADEING	C. C. DIA (MM)							
AREA (SQ MM)	575.9	UNSPECIFIED THICKNESS	---	PERIMETER (MM)	384.3	STANDARD		SCALE	1:1
MASS (KG/M)	1.561	UNSPECIFIED CORNERS	R=0.3	SURFACE AREA	22	ALLOY	6063-T5	VERSION	
COMPANY ISSUE			DRAWA	AN	DATE	21-11-24	APELLATION	-	PAGE OF
			STANDA-		DATE				
			RDIZATION		DATE				
			TO SIGN		DATE				
			AUDITING		DATE				
MARKER	MODIFY	FILE NO	SIGNATURE	DATE	APPROV	DATE			

 美特鋁質有限公司
MIDI Aluminium Fabricator Ltd.

CUSTOMER	CUSTOMER APPROVAL	CUST PART NO.	AL81
		SECTION NO.	X86085

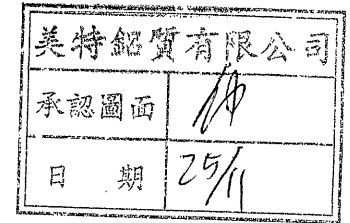
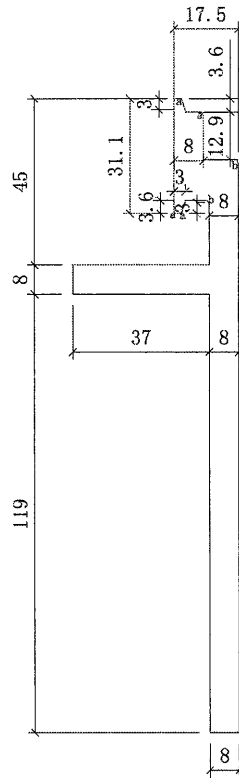

AL67
X86057

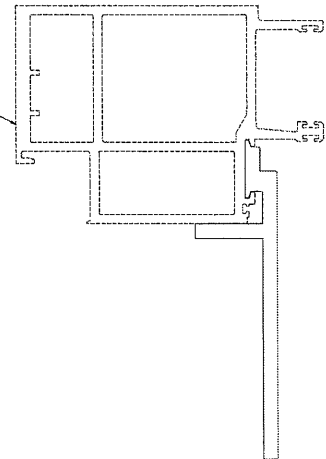

$p=R0.3 \times 0.3$

$a=R 0.5 \quad b=R 1$

SIGNATURE GRADEING	HIGH SIGNATURE GRADEING	C. C. DIA (MM)							
AREA (SQ MM)	1765.8	UNSPECIFIED THICKNESS	--	PERIMETER (MM)	456.6	STANDARD		SCALE	1:1
MASS (KG/M)	4.786	UNSPECIFIED CORNERS	R=0.3	SURFACE AREA	0	ALLOY	6061-T6	VERSION	
COMPANY ISSUE			DRAWN	AN	DATE	21-11-24	APELLATION	-	PAGE OF
			STANDARDIZATION		DATE		 美特鋁質有限公司 MIDI Aluminium Fabricator Ltd.		
			TO SIGN		DATE				
			AUDITING		DATE				
MARKER	MODIFY	FILE NO	SIGNATURE	DATE	APPROV	DATE			

CUSTOMER	CUSTOMER APPROVAL	CUST PART NO.	AL83
		SECTION NO.	X86087

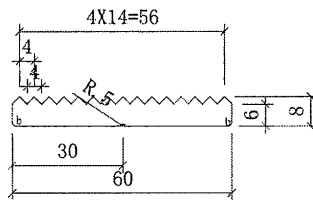

美特鋁質有限公司	
承認圖面	<i>[Signature]</i>
日期	25/11

p=R0.3X0.3

a=R 0.5 b=R 1

AL45
X86077

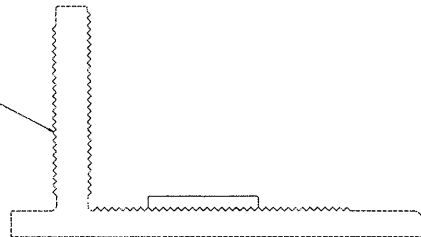

SIGNATURE GRADEING	HIGH SIGNATURE GRADEING	C. C. DIA (MM)							
AREA (SQ MM)	419.2	UNSPECIFIED THICKNESS	--	PERIMETER (MM)	156.6	STANDARD		SCALE	1:1
MASS (KG/M)	1.135	UNSPECIFIED CORNERS	R=0.3	SURFACE AREA	0	ALLOY	6063-T5	VERSION	
COMPANY ISSUE			DRAWN	AN	DATE	21-11-24	APPELLATION	-	PAGE OF
			STANDARDIZATION		DATE				
			TO SIGN		DATE				
			AUDITING		DATE				
MARKER	MODIFY	FILE NO	SIGNATURE	DATE	APPROV	DATE			

CUSTOMER		CUSTOMER APPROVAL		CUST PART NO.	AL87
				SECTION NO.	X86088

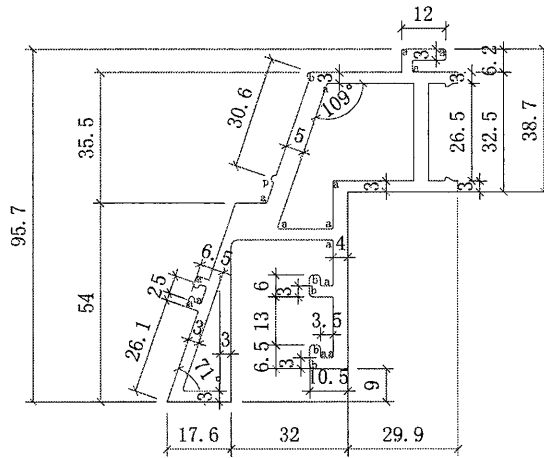

美特鋁質有限公司	
承認圖面	<i>[Signature]</i>
日期	25/11

p=R 1X1
a=R 0.5 b=R 1

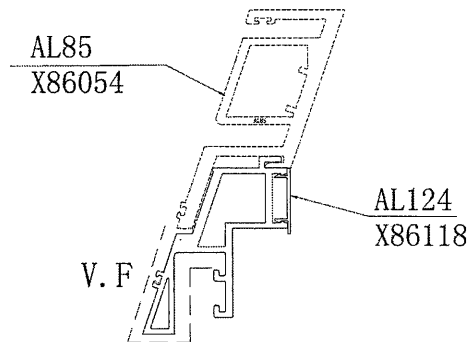

SIGNATURE GRADEING	HIGH SIGNATURE GRADEING	C. C. DIA (MM)							
AREA (SQ MM)	1289	UNSPECIFIED THICKNESS	--	PERIMETER (MM)	689.3	STANDARD		SCALE	1:1
MASS (KG/M)	3.493	UNSPECIFIED CORNERS	R=0.3	SURFACE AREA	161	ALLOY	6063-T6	VERSION	
COMPANY ISSUE			DRAWN	AN	DATE	21-11-24	APPELLATION	-	PAGE OF
			STANDARDIZATION		DATE				
			TO SIGN		DATE				
			AUDITING		DATE				
MARKER	MODIFY	FILE NO	SIGNATURE	DATE	APPROV				

美特鋁質有限公司
MIDI Aluminium Fabricator Ltd.

CUSTOMER		CUSTOMER APPROVAL	CUST PART NO.	AL89
			SECTION NO.	X86090

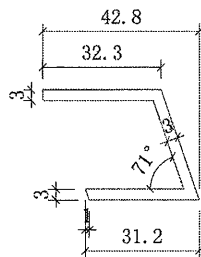

美特鋁質有限公司	
承認圖面	仲
日期	25/11

p=R0.8X0.8
a=R 0.5 b=R 1

SIGNATURE GRADEING	HIGH SIGNATURE GRADEING	C. C. DIA (MM)							
AREA (SQ MM)	265.4	UNSPECIFIED THICKNESS	--	PERIMETER (MM)	183.1	STANDARD		SCALE	1:1
MASS (KG/M)	0.719	UNSPECIFIED CORNERS	R=0.3	SURFACE AREA	0	ALLOY	6063-T6	VERSION	
COMPANY ISSUE			DRAWN	AN	DATE	21-11-24	APELLATION	-	PAGE OF
			STANDARDIZATION		DATE				
			TO SIGN		DATE				
			AUDITING		DATE				
MARKER	MODIFY	FILE NO	SIGNATURE	DATE	APPROV		DATE		



美特鋁質有限公司
MIDI Aluminium Fabricator Ltd.

CUSTOMER	CUSTOMER APPROVAL	CUST PART NO.	AL90
		SECTION NO.	X86091

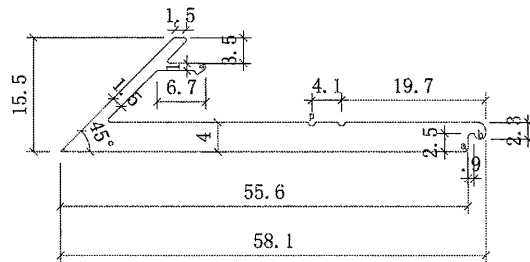

2:1

美特鋁質有限公司	
承認圖面	<i>[Signature]</i>
日期	25/11

AL91
X86092

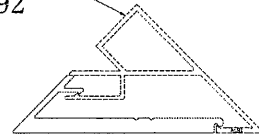

p=R0.5X0.5

a=R 0.5 b=R 1

SIGNATURE GRADEING	HIGH SIGNATURE GRADEING	C. C. DTA (MM)							
AREA (SQ MM)	249.1	UNSPECIFIED THICKNESS	--	PERIMETER (MM)	164.5	STANDARD		SCALE	1:1
MASS (KG/M)	0.675	UNSPECIFIED CORNERS	R=0.3	SURFACE AREA	0	ALLOY	6063-T6	VERSION	
COMPANY ISSUE			DRAWN	AN	DATE	21-11-24	APELLATION	-	PAGE OF
			STANDARDIZATION		DATE				
			TO SIGN		DATE				
			AUDITING		DATE				
MARKER	MODIFY	FILE NO	SIGNATURE	DATE	APPROV				

美特鋁質 有限公司
MIDI Aluminium Fabricator Ltd.

CUSTOMER		CUSTOMER APPROVAL		CUST PART NO.	AL91
				SECTION NO.	X86092

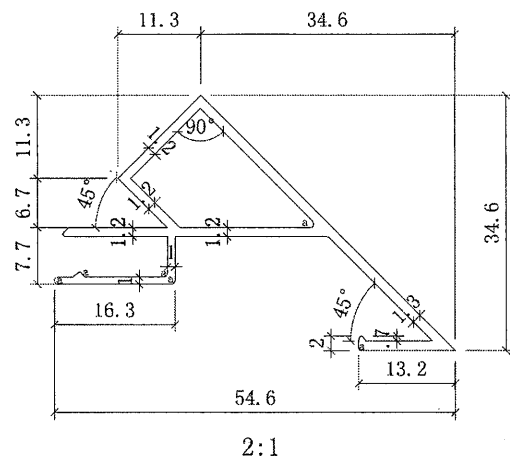

美特鋁質有限公司	
承認圖面	<i>[Signature]</i>
日期	25/11

p=R0.5X0.5
a=R 0.5 b=R 1

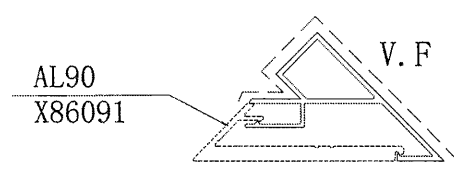

SIGNATURE GRADEING	HIGH SIGNATURE GRADEING	C. C. DIA (MM)							
AREA (SQ MM)	170.2	UNSPECIFIED THICKNESS	--	PERIMETER (MM)	277.3	STANDARD		SCALE	1:1
MASS (KG/M)	0.461	UNSPECIFIED CORNERS	R=0.3	SURFACE AREA	175	ALLOY	6063-T5	VERSION	
COMPANY ISSUE			DRAWN	AN	DATE	21-11-24	APPELLATION	-	PAGE OF
			STANDARDIZATION		DATE				
			TO SIGN		DATE				
			AUDITING		DATE				
MARKER	MODIFY	FILE NO	SIGNATURE	DATE	APPROV	DATE			

CUSTOMER		CUSTOMER APPROVAL	CUST PART NO.	AL92
			SECTION NO.	X86093

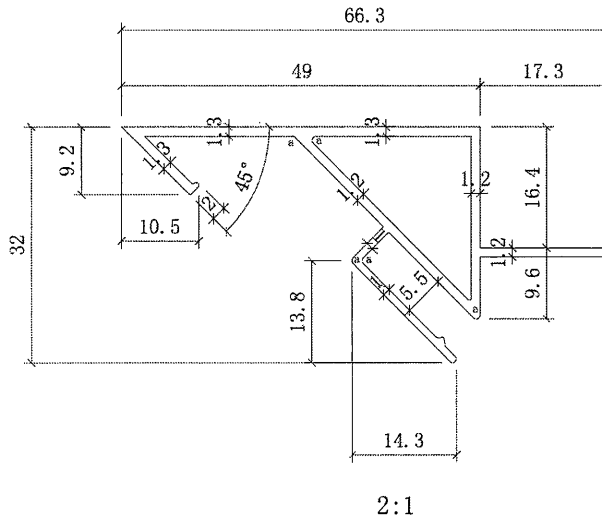

美特鋁質有限公司	
承認圖面	<i>[Signature]</i>
日期	25/11

p=R0.5X0.5
a=R 0.5 b=R 1

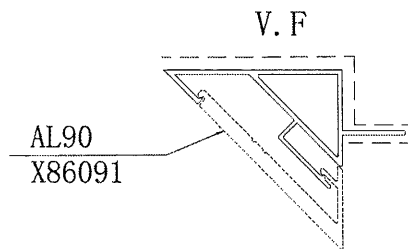

SIGNATURE GRADEING	HIGH SIGNATURE GRADEING	C. C. DIA (MM)							
AREA (SQ MM)	193.5	UNSPECIFIED THICKNESS	--	PERIMETER (MM)	315.8	STANDARD		SCALE	1:1
MASS (KG/M)	0.526	UNSPECIFIED CORNERS	R=0.3	SURFACE AREA	201	ALLOY	6063-T5	VERSION	
COMPANY ISSUE			DRAWA	AN	DATE	21-11-24	APELLATION	-	PAGE OF
			STANDA- RDIZATION		DATE				
			TO SIGN		DATE				
			AUDITING		DATE				
MARKER	MODIFY	FILE NO	SIGNATURE	DATE	APPROV				

美特鋁質 有限公司
MIDI Aluminium Fabricator Ltd.

CUSTOMER	CUSTOMER APPROVAL	CUST PART NO.	AL94
		SECTION NO.	X86095

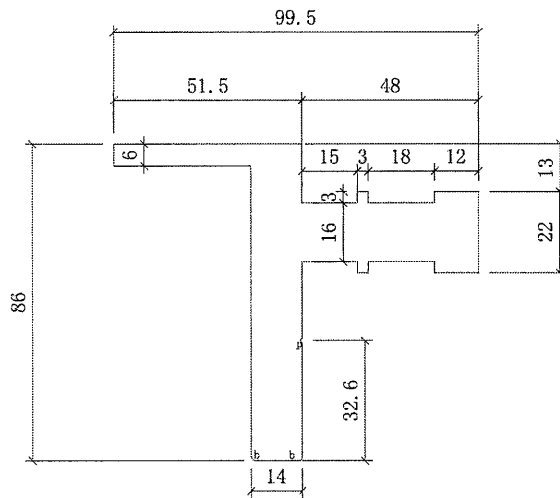

美特鋁質有限公司	
承認圖面	<i>[Signature]</i>
日期	25/11

p=R0.5X0.5

a=R 0.5 b=R 1

SIGNATURE GRADEING	HIGH SIGNATURE GRADEING	C. C. DIA (MM)							
AREA (SQ MM)	2286.2	UNSPECIFIED THICKNESS	---	PERIMETER (MM)	394.7	STANDARD		SCALE	1:1
MASS (KG/M)	6.195	UNSPECIFIED CORNERS	R=0.3	SURFACE AREA	0	ALLOY	6061-T6	VERSION	
COMPANY ISSUE			DRAWN	AN	DATE	21-11-24	APELLATION	-	PAGE OF
			STANDARDIZATION		DATE				
			TO SIGN		DATE				
			AUDITING		DATE				
MARKER	MODIFY	FILE NO	SIGNATURE	DATE	APPROV				

 美特鋁質有限公司
MIDI Aluminium Fabricator Ltd.

CUSTOMER	CUSTOMER APPROVAL	CUST PART NO.	AL95
		SECTION NO.	X86096

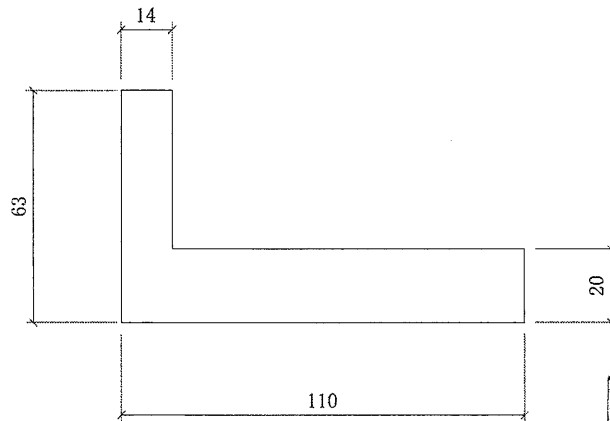

美特鋁質有限公司	
承認圖面	<i>Handwritten signature</i>
日期	25/11

p=R0.5X0.5

a=R 0.5 b=R 1

SIGNATURE GRADEING	HIGH SIGNATURE GRADEING	C. C. DIA (MM)							
AREA (SQ MM)	2802	UNSPECIFIED THICKNESS	--	PERIMETER (MM)	346	STANDARD		SCALE	1:1
MASS (KG/M)	7.593	UNSPECIFIED CORNERS	R=0.3	SURFACE AREA	0	ALLOY	6061-T6	VERSION	
COMPANY ISSUE			DRAWN	AN	DATE	21-11-24	APPELLATION	-	PAGE OF
			STANDARDIZATION		DATE				
			TO SIGN		DATE				
			AUDITING		DATE				
MARKER	MODIFY	FILE NO	SIGNATURE	DATE	APPROV		DATE		

 美特鋁質有限公司
MIDI Aluminium Fabricator Ltd.

CUSTOMER		CUSTOMER APPROVAL		CUST PART NO.	AL96
				SECTION NO.	X86097

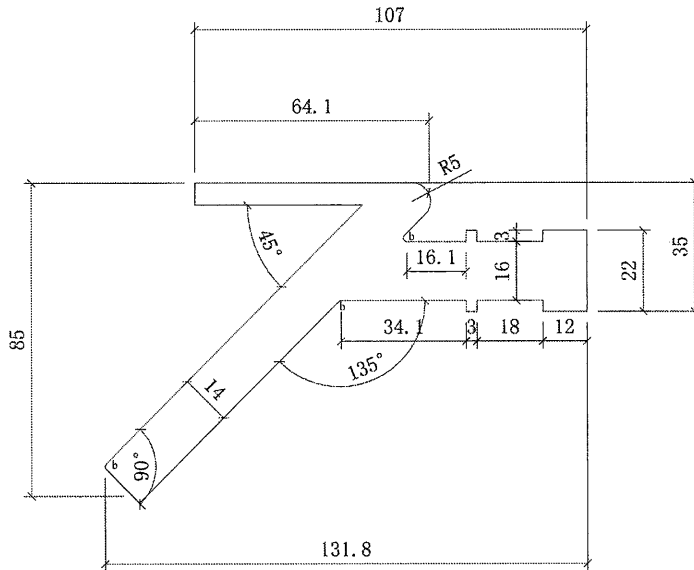

英特鋁質有限公司	
承認圖面	仲
日期	25/11

p=R0.5X0.5

a=R 0.5 b=R 1

SIGNATURE GRADEING	HIGH SIGNATURE GRADEING	C. C. DIA (MM)							
AREA (SQ MM)	2926	UNSPECIFIED THICKNESS	---	PERIMETER (MM)	481.5	STANDARD		SCALE	1:1
MASS (KG/M)	7.929	UNSPECIFIED CORNERS	R=0.3	SURFACE AREA	0	ALLOY	6061-T6	VERSION	
COMPANY ISSUE			DRAWA	AN	DATE	21-11-24	APELLATION	-	PAGE OF
			STANDA- RDIZATION		DATE		 美特鋁質 有限公司 MIDI Aluminium Fabricator Ltd.		
			TO SIGN		DATE				
			AUDITING		DATE				
MARKER	MODIFY	FILE NO	SIGNATURE	DATE	APPROV	DATE			

CUSTOMER	CUSTOMER APPROVAL	CUST PART NO.	AL97
		SECTION NO.	X86098

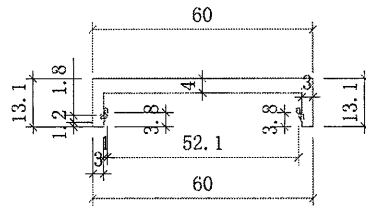

美特鋁質有限公司	
承認圖面	<i>[Signature]</i>
日期	25/11

p=R0.5X0.5
a=R 0.5 b=R 1

V. F
AL98
X86099

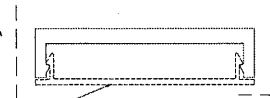

SIGNATURE GRADEING	HIGH SIGNATURE GRADEING	C. C. DIA (MM)							
AREA (SQ MM)	297.6	UNSPECIFIED THICKNESS	---	PERIMETER (MM)	166.4	STANDARD		SCALE	1:1
MASS (KG/M)	0.806	UNSPECIFIED CORNERS	R=0.3	SURFACE AREA	32	ALLOY	6063-T5	VERSION	
COMPANY ISSUE			DRAWA	AN	DATE	APPELLATION		PAGE OF	
			STANDA-		21-11-24	-			
			RDIZATION		DATE				
			TO SIGN		DATE				
			AUDITING		DATE				
MARKER	MODIFY	FILE NO	SIGNATURE	DATE	APPROV				

美特鋁質有限公司
MIDI Aluminium Fabricator Ltd.

CUSTOMER	CUSTOMER APPROVAL	CUST PART NO.	AL99
		SECTION NO.	X86100

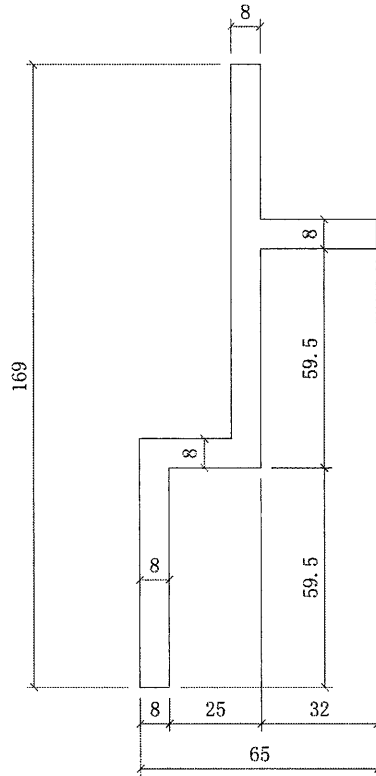

美特鋁質有限公司	
承認圖面	<i>[Signature]</i>
日期	25/11

$p=R0.5 \times 0.5$
 $a=R0.5$ $b=R1$

SIGNATURE GRADEING	HIGH SIGNATURE GRADEING	C. C. DIA (MM)							
AREA (SQ MM)	1808	UNSPECIFIED THICKNESS	--	PERIMETER (MM)	468	STANDARD		SCALE	1:1
MASS (KG/M)	4.90	UNSPECIFIED CORNERS	R=0.3	SURFACE AREA	0	ALLOY	6061-T6	VERSION	
COMPANY ISSUE			DRAWN	AN	DATE	21-11-24	APPELLATION	-	PAGE OF
			STANDARDIZATION		DATE				
			TO SIGN		DATE				
			AUDITING		DATE				
MARKER	MODIFY FILE NO	SIGNATURE	DATE	APPROV		DATE			

CUSTOMER	CUSTOMER APPROVAL	CUST PART NO.	AL101
		SECTION NO.	X86102

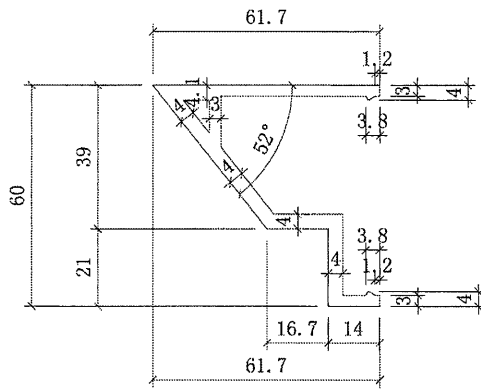

美特鋁質有限公司	
承認圖面	<i>[Signature]</i>
日期	25/11

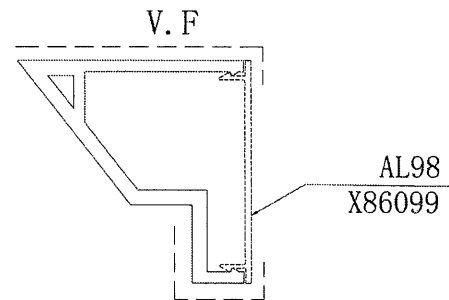

p=R0.5X0.5
a=R 0.5 b=R 1

SIGNATURE GRADEING	HIGH SIGNATURE GRADEING	C. C. DIA (MM)							
AREA (SQ MM)	594.7	UNSPECIFIED THICKNESS	---	PERIMETER (MM)	329.5	STANDARD		SCALE	1:1
MASS (KG/M)	1612	UNSPECIFIED CORNERS	R=0.3	SURFACE AREA	97	ALLOY	6063-T6	VERSION	
COMPANY ISSUE			DRAWN	AN	DATE	21-11-24	APPELLATION	-	PAGE OF
			STANDARDIZATION		DATE				
			TO SIGN		DATE				
			AUDITING		DATE				
MARKER	MODIFY	FILE NO	SIGNATURE	DATE	APPROV				

美特鋁質 有限公司
MIDI Aluminium Fabricator Ltd.

CUSTOMER		CUSTOMER APPROVAL	CUST PART NO.	AL102
			SECTION NO.	X86103

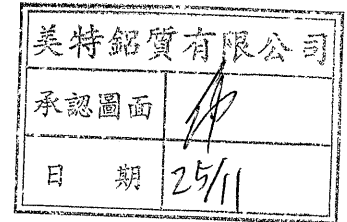
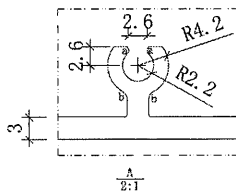
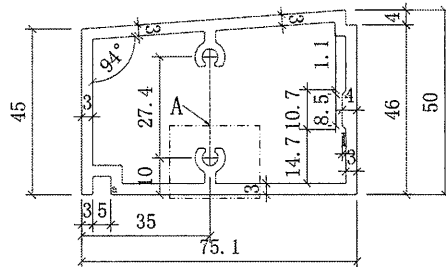

V. F

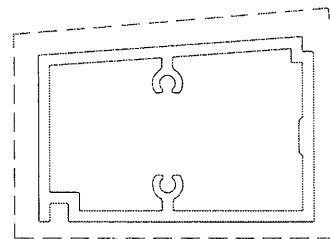

p=R0.5X0.5

a=R 0.5 b=R 1

SIGNATURE GRADEING	HIGH SIGNATURE GRADEING	C. C. DIA (MM)							
AREA (SQ MM)	594.7	UNSPECIFIED THICKNESS	--	PERIMETER (MM)	329.5	STANDARD		SCALE	1:1
MASS (KG/M)	1.612	UNSPECIFIED CORNERS	R=0.3	SURFACE AREA	201	ALLOY	6063-T5	VERSION	
COMPANY ISSUE			DRAWA	AN	DATE	21-11-24	APELLATION	-	PAGE OF
			STANDA-RDIZATION		DATE				
			TO SIGN		DATE				
			AUDITING		DATE				
MARKER	MODIFY	FILE NO	SIGNATURE	DATE	APPROV				

美特鋁質有限公司
MIDI Aluminium Fabricator Ltd.

CUSTOMER		CUSTOMER APPROVAL		CUST PART NO.	AL103
				SECTION NO.	X86104

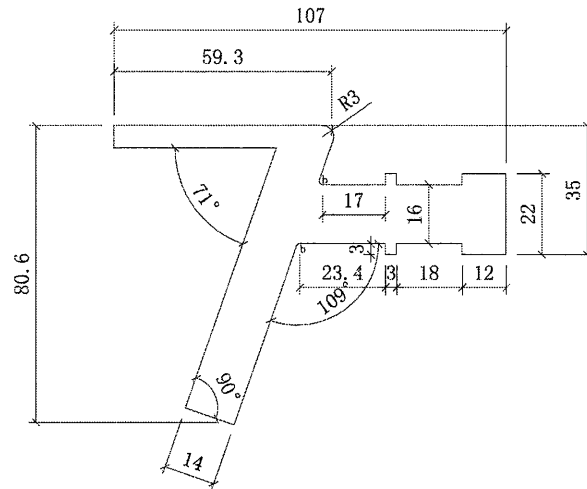

美特鋁質有限公司	
承認圖面	<i>[Signature]</i>
日期	25/11

p=R0.5X0.5

a=R 0.5 b=R 1

SIGNATURE GRADEING	HIGH SIGNATURE GRADEING	C. C. DIA (MM)							
AREA (SQ MM)	2396	UNSPECIFIED THICKNESS	--	PERIMETER (MM)	414.0	STANDARD		SCALE	1:1
MASS (KG/M)	6.493	UNSPECIFIED CORNERS	R=0.3	SURFACE AREA	0	ALLOY	6061-T6	VERSION	
COMPANY ISSUE			DRAWA	AN	DATE	21-11-24	APELLATION	-	PAGE OF
			STANDA-		DATE				
			RDIZATION		DATE				
			TO SIGN		DATE				
			AUDITING		DATE				
MARKER	MODIFY	FILE NO	SIGNATURE	DATE	APPROV				

 美特鋁質有限公司
MIDI Aluminium Fabricator Ltd.

CUSTOMER	CUSTOMER APPROVAL	CUST PART NO.	AL112
		SECTION NO.	X86106

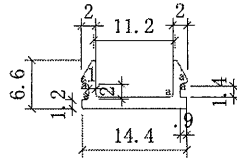

2:1

美特鋁質有限公司	
承認圖面	<i>[Signature]</i>
日期	25/11

p=R0.5X0.5
a=R 0.5 b=R 1

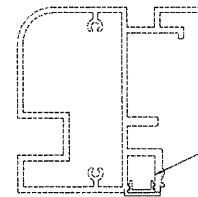

AL104
X86105

V. F

SIGNATURE GRADEING	HIGH SIGNATURE GRADEING	C. C. DIA (MM)							
AREA (SQ MM)	35.0	UNSPECIFIED THICKNESS	--	PERIMETER (MM)	52.1	STANDARD		SCALE	1:1
MASS (KG/M)	0.09	UNSPECIFIED CORNERS	R=0.3	SURFACE AREA	14.4	ALLOY	6063-T5	VERSION	
COMPANY ISSUE			DRAWN	AN	DATE	21-11-24	APELLATION	-	PAGE OF
			STANDARDIZATION		DATE				
			TO SIGN		DATE				
			AUDITING		DATE				
MARKER	MODIFY	FILE NO	SIGNATURE	DATE	APPROV				

美特鋁質有限公司
MIDI Aluminium Fabricator Ltd.

CUSTOMER	CUSTOMER APPROVAL	CUST PART NO.	AL114
		SECTION NO.	X86143

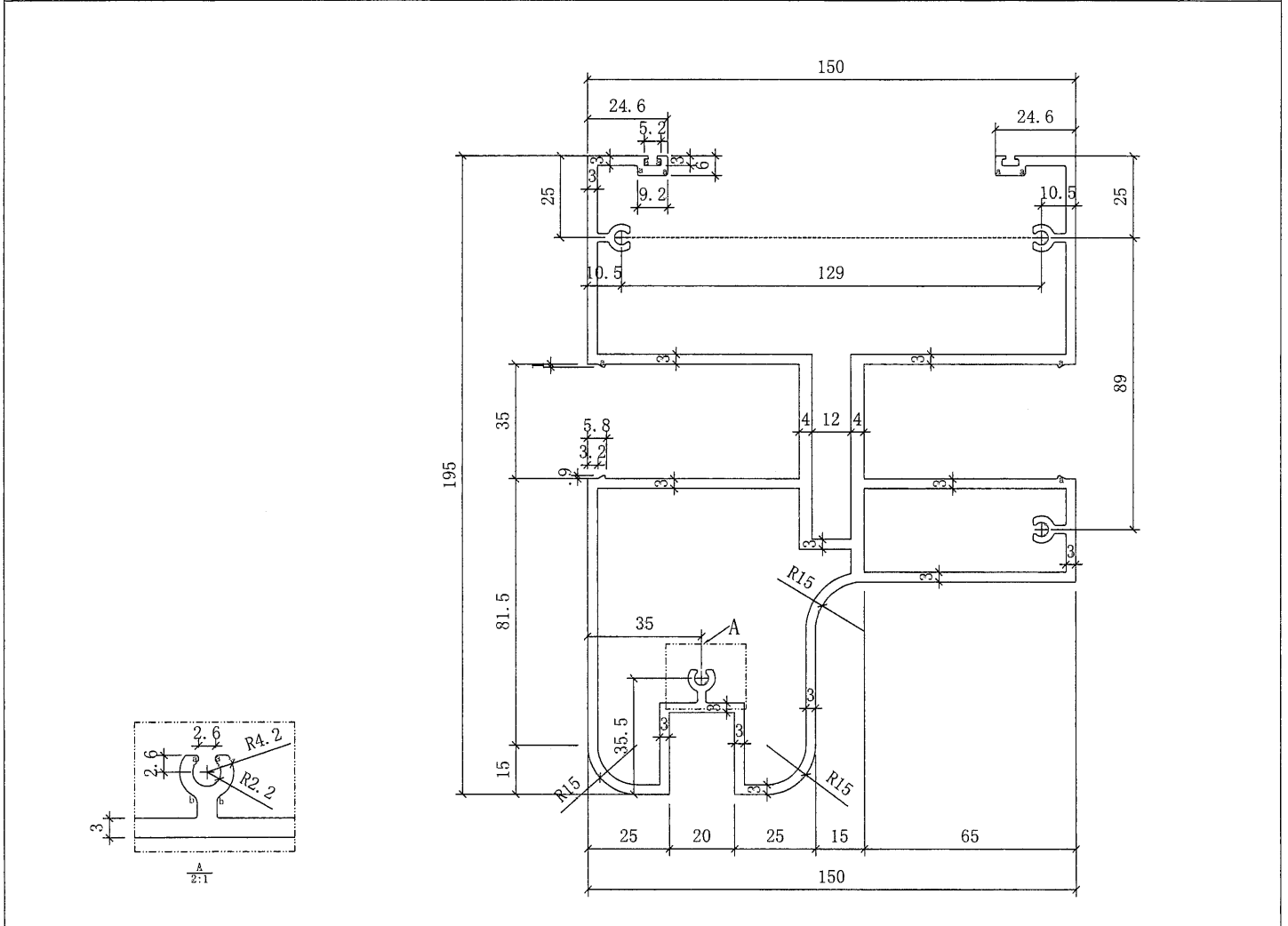

美特鋁質有限公司	
承認圖面	<i>[Signature]</i>
日期	25/11

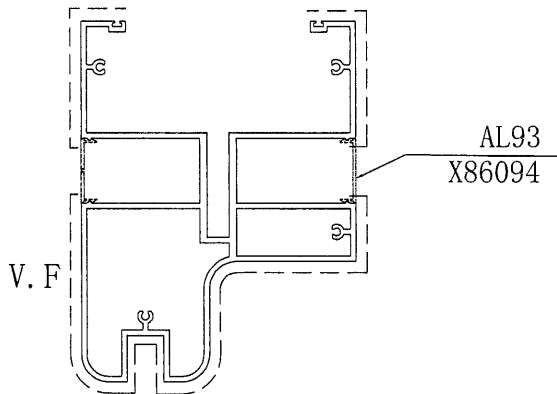

p=R0.5X0.5
a=R 0.5 b=R 1

SIGNATURE GRADEING	HIGH SIGNATURE GRADEING	C. C. DIA (MM)							
AREA (SQ MM)	3092.9	UNSPECIFIED THICKNESS	---	PERIMETER (MM)	2023.1	STANDARD		SCALE	1:1
MASS (KG/M)	8.382	UNSPECIFIED CORNERS	R=0.3	SURFACE AREA	581	ALLOY	6063-T5	VERSION	
COMPANY ISSUE			DRAWN	AN	DATE	21-11-24	APELLATION	-	PAGE OF
			STANDARDIZATION		DATE				
			TO SIGN		DATE				
			AUDITING		DATE				
MARKER	MODIFY	FILE NO	SIGNATURE	DATE	APPROV				

美特鋁質有限公司
MIDI Aluminium Fabricator Ltd.

CUSTOMER		CUSTOMER APPROVAL	CUST PART NO.	AL115
			SECTION NO.	X86144

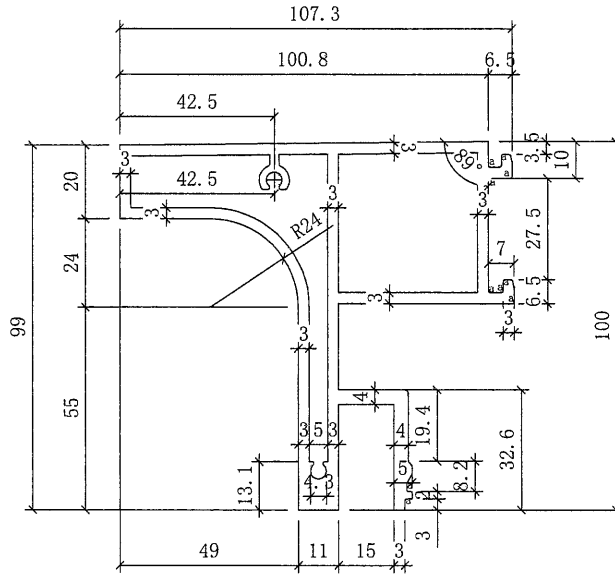

美特鋁質有限公司	
承認圖面	<i>[Signature]</i>
日期	25/11

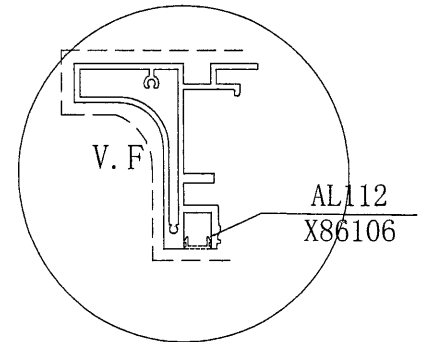

p=R0.5X0.5
a=R 0.5 b=R 1

SIGNATURE GRADEING	HIGH SIGNATURE GRADEING	C. C. DIA (MM)							
AREA (SQ MM)	1570.6	UNSPECIFIED THICKNESS	---	PERIMETER (MM)	984.6	STANDARD		SCALE	1:1
MASS (KG/M)	4.271	UNSPECIFIED CORNERS	R=0.3	SURFACE AREA	324	ALLOY	6063-T5	VERSION	
COMPANY ISSUE			DRAWN	AN	DATE	21-11-24	APPELLATION	-	PAGE OF
			STANDARDIZATION		DATE				
			TO SIGN		DATE				
			AUDITING		DATE				
MARKER	MODIFY	FILE NO	SIGNATURE	DATE	APPROV				

美特鋁質有限公司
MIDI Aluminium Fabricator Ltd.

CUSTOMER	CUSTOMER APPROVAL	CUST PART NO.	AL116
		SECTION NO.	X86145

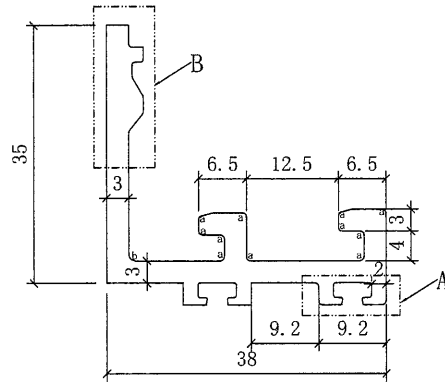

2:1

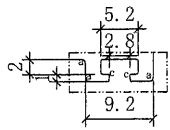

A
2:1

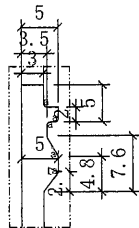

B
2:1

美特鋁質有限公司	
承認圖面	<i>[Signature]</i>
日期	25/11

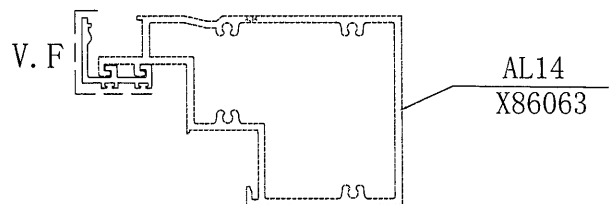

p=R0.5X0.5

a=R 0.5 b=R 1

SIGNATURE GRADEING	HIGH SIGNATURE GRADEING	C. C. DIA (MM)							
AREA (SQ MM)	315.2	UNSPECIFIED THICKNESS	--	PERIMETER (MM)	219.0	STANDARD		SCALE	1:1
MASS (KG/M)	0.854	UNSPECIFIED CORNERS	R=0.3	SURFACE AREA	48	ALLOY	6063-T6	VERSION	
COMPANY ISSUE			DRAWN	AN	DATE	21-11-24	APELLATION	-	PAGE OF
			STANDARDIZATION		DATE				
			TO SIGN		DATE				
			AUDITING		DATE				
MARKER	MODIFY	FILE NO	SIGNATURE	DATE	APPROV				

美特鋁質有限公司
MIDI Aluminium Fabricator Ltd.

CUSTOMER		CUSTOMER APPROVAL		CUST PART NO.	AL118
				SECTION NO.	X86146

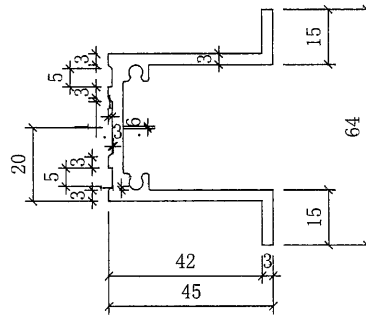

美特鋁質有限公司	
承認圖面	<i>[Signature]</i>
日期	25/11

p=R0.5X0.5

a=R 0.5 b=R 1

SIGNATURE GRADEING	HIGH SIGNATURE GRADEING	C. C. DIA (MM)							
AREA (SQ MM)	486.5	UNSPECIFIED THICKNESS	--	PERIMETER (MM)	317.7	STANDARD		SCALE	1:1
MASS (KG/M)	1.320	UNSPECIFIED CORNERS	R=0.3	SURFACE AREA	0	ALLOY	6061-T6	VERSION	
COMPANY ISSUE			DRAWA	AN	DATE	21-11-24	APPELLATION	-	PAGE OF
			STANDA-RDIZATION		DATE				
			TO SIGN		DATE				
			AUDITING		DATE				
MARKER	MODIFY	FILE NO	SIGNATURE	DATE	APPROV				

 美特鋁質有限公司
MIDI Aluminium Fabricator Ltd.

CUSTOMER		CUSTOMER APPROVAL		CUST PART NO.	AL119
				SECTION NO.	X86147

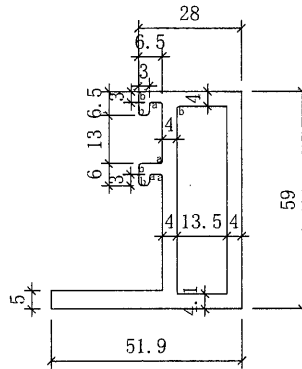

美特鋁質有限公司	
承認圖面	<i>[Signature]</i>
日期	25/11

p=R0.5X0.5
a=R 0.5 b=R 1

AL76A
X86080

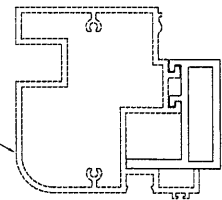

SIGNATURE GRADEING	HIGH SIGNATURE GRADEING	C. C. DIA (MM)							
AREA (SQ MM)	790.9	UNSPECIFIED THICKNESS	--	PERIMETER (MM)	385.5	STANDARD		SCALE	1:1
MASS (KG/M)	2.144	UNSPECIFIED CORNERS	R=0.3	SURFACE AREA	0	ALLOY	6061-T6	VERSION	
COMPANY ISSUE			DRAWA	AN	DATE	21-11-24	APELLATION	-	PAGE OF
			STANDA- RDIZATION		DATE				
			TO SIGN		DATE				
			AUDITING		DATE				
MARKER	MODIFY	FILE NO	SIGNATURE	DATE	APPROV				

美特鋁質有限公司
MIDI Aluminium Fabricator Ltd.

CUSTOMER	CUSTOMER APPROVAL	CUST PART NO.	AL120
		SECTION NO.	X86148

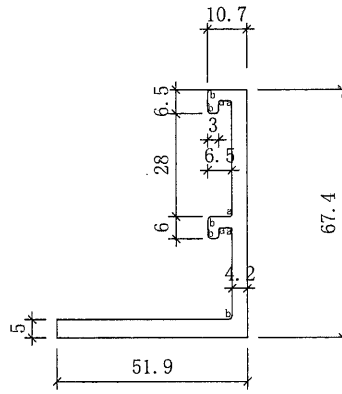

美特鋁質有限公司	
承認圖面	<i>[Signature]</i>
日期	25/11

p=R0.5X0.5
a=R 0.5 b=R 1

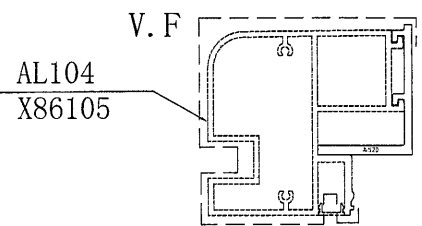

SIGNATURE GRADEING	HIGH SIGNATURE GRADEING	C. C. DIA (MM)							
AREA (SQ MM)	579	UNSPECIFIED THICKNESS	--	PERIMETER (MM)	273.4	STANDARD		SCALE	1:1
MASS (KG/M)	1.569	UNSPECIFIED CORNERS	R=0.3	SURFACE AREA	0	ALLOY	6061-T6	VERSION	
COMPANY ISSUE			DRAWN	AN	DATE	21-11-24	APELLATION	-	PAGE OF
			STANDARDIZATION		DATE				
			TO SIGN		DATE				
			AUDITING		DATE				
MARKER	MODIFY	FILE NO	SIGNATURE	DATE	APPROV				

美特鋁質有限公司
MIDI Aluminium Fabricator Ltd.

CUSTOMER	CUSTOMER APPROVAL	CUST PART NO.	AL121
		SECTION NO.	X86149

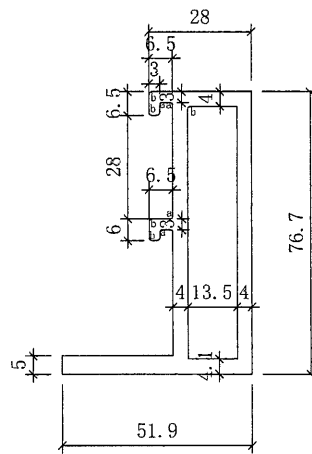

美特鋁質有限公司	
承認圖面	<i>[Signature]</i>
日期	25/11

p=R0.5X0.5
a=R 0.5 b=R 1

AL77
X86081

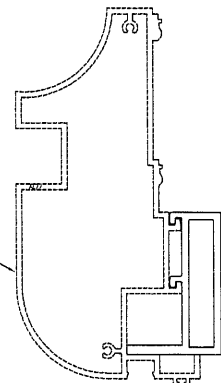

SIGNATURE GRADEING	HIGH SIGNATURE GRADEING	C. C. DIA (MM)							
AREA (SQ MM)	932.6	UNSPECIFIED THICKNESS	--	PERIMETER (MM)	456.3	STANDARD		SCALE	1:1
MASS (KG/M)	2.526	UNSPECIFIED CORNERS	R=0.3	SURFACE AREA	0	ALLOY	6061-T6	VERSION	
COMPANY ISSUE			DRAWN	AN	DATE	21-11-24	APELLATION	-	PAGE OF
			STANDARDIZATION		DATE				
			TO SIGN		DATE				
			AUDITING		DATE				
MARKER	MODIFY	FILE NO	SIGNATURE	DATE	APPROV				

美特鋁質有限公司
MIDI Aluminium Fabricator Ltd.

CUSTOMER	CUSTOMER APPROVAL	CUST PART NO.	AL122
		SECTION NO.	X86150

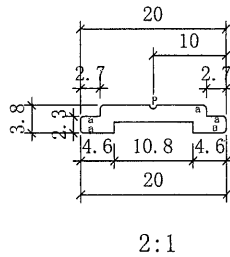

美特鋁質有限公司	
承認圖面	<i>[Signature]</i>
日期	25/11

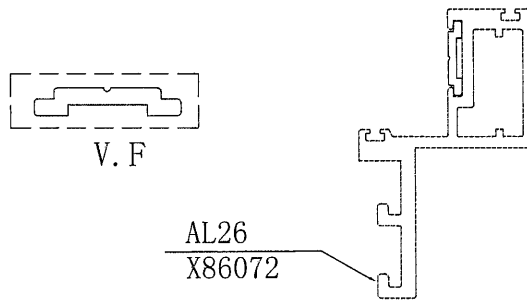

p=R0.5X0.5
a=R 0.5 b=R 1

SIGNATURE GRADEING	HIGH SIGNATURE GRADEING	C. C. DIA (MM)							
AREA (SQ MM)	51	UNSPECIFIED THICKNESS	---	PERIMETER (MM)	49.9	STANDARD		SCALE	1:1
MASS (KG/M)	0.138	UNSPECIFIED CORNERS	R=0.3	SURFACE AREA	50	ALLOY	6061-T6	VERSION	
COMPANY ISSUE			DRAWN	AN	DATE	21-11-24	APELLATION	-	PAGE OF
			STANDARDIZATION		DATE				
			TO SIGN		DATE				
			AUDITING		DATE				
MARKER	MODIFY	FILE NO	SIGNATURE	DATE	APPROV				

美特鋁質有限公司
MIDI Aluminium Fabricator Ltd.

CUSTOMER		CUSTOMER APPROVAL		CUST PART NO.	AL123
				SECTION NO.	X86151

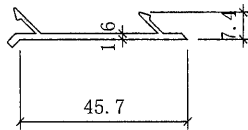

美特鋁質有限公司	
承認圖面	<i>AA</i>
日期	25/11

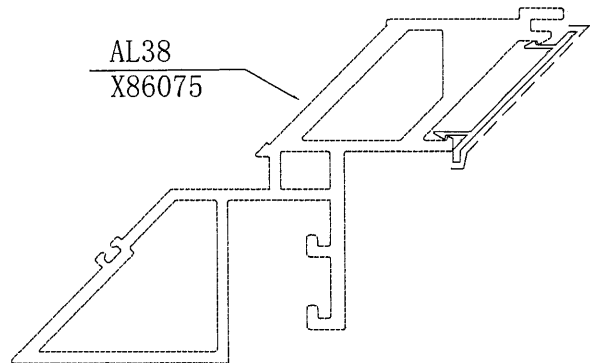

p=R0.5X0.5
a=R 0.5 b=R 1

SIGNATURE GRADEING	HIGH SIGNATURE GRADEING	C. C. DIA (MM)							
AREA (SQ MM)	46	UNSPECIFIED THICKNESS	--	PERIMETER (MM)	137	STANDARD		SCALE	1:1
MASS (KG/M)	0.268	UNSPECIFIED CORNERS	R=0.3	SURFACE AREA	46	ALLOY	6063-T5	VERSION	
COMPANY ISSUE			DRAWN	AN	DATE	21-11-24	APPELLATION	-	PAGE OF
			STANDARDIZATION		DATE		 美特鋁質有限公司 MIDI Aluminium Fabricator Ltd.		
			TO SIGN		DATE				
			AUDITING		DATE				
MARKER	MODIFY	FILE NO	SIGNATURE	DATE	APPROV	DATE			

CUSTOMER		CUSTOMER APPROVAL		CUST PART NO.	AL124
				SECTION NO.	X86152

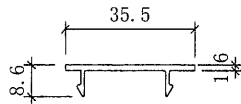

美特鋁質有限公司	
承認圖面	<i>[Signature]</i>
日期	25/11

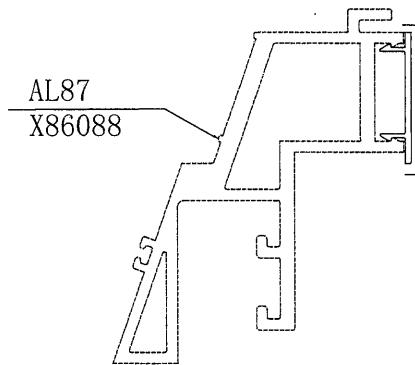

p=R0.5X0.5
a=R 0.5 b=R 1

SIGNATURE GRADEING	HIGH SIGNATURE GRADEING	C. C. DIA (MM)							
AREA (SQ MM)	46	UNSPECIFIED THICKNESS	--	PERIMETER (MM)	137	STANDARD		SCALE	1:1
MASS (KG/M)	0.268	UNSPECIFIED CORNERS	R=0.3	SURFACE AREA	46	ALLOY	6063-T5	VERSION	
COMPANY ISSUE			DRAWN	AN	DATE	21-11-24	APPELLATION	-	PAGE OF
			STANDARDIZATION		DATE				
			TO SIGN		DATE				
			AUDITING		DATE				
MARKER	MODIFY	FILE NO	SIGNATURE	DATE	APPROV				

 美特鋁質有限公司
MIDI Aluminium Fabricator Ltd.