

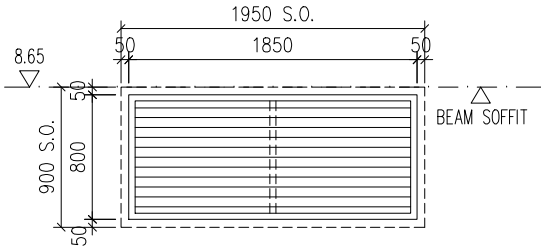

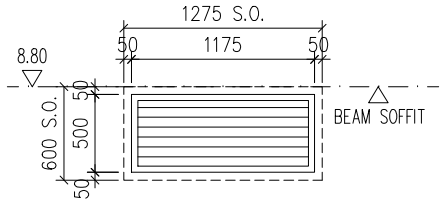

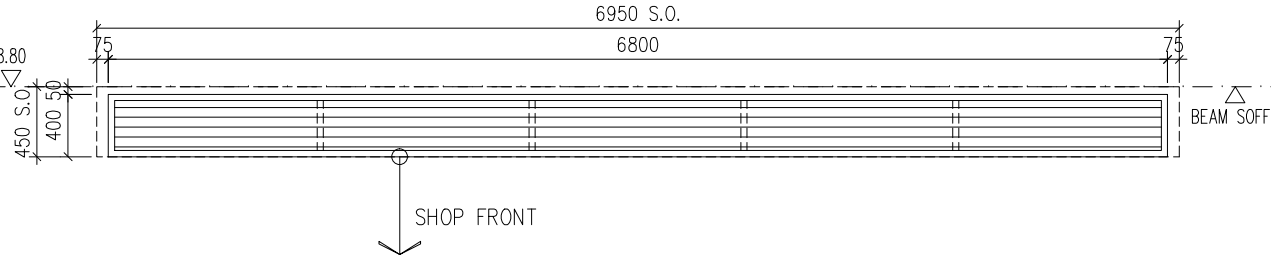

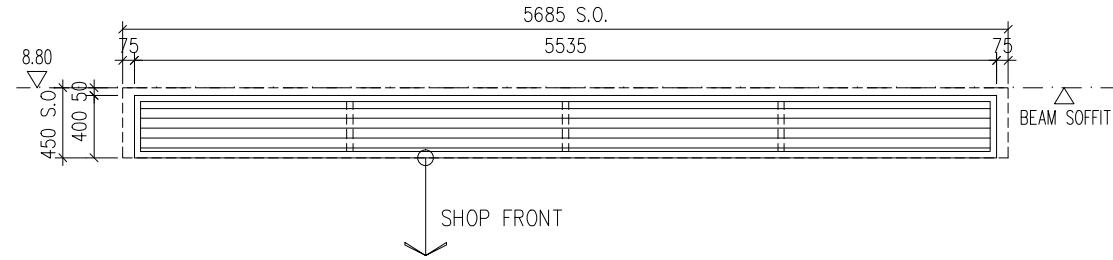

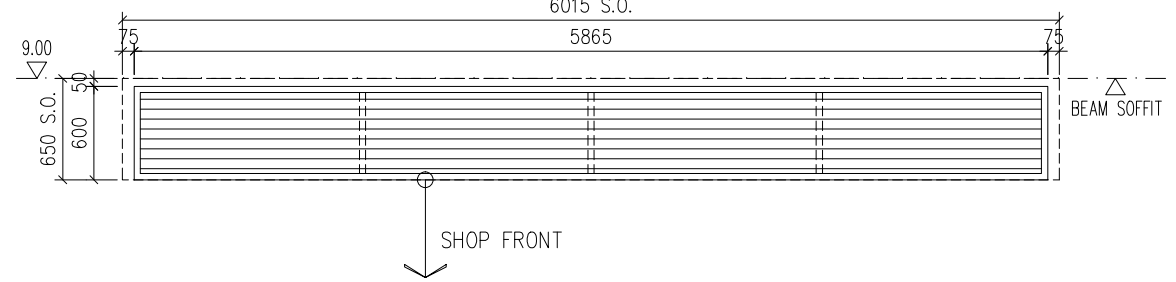



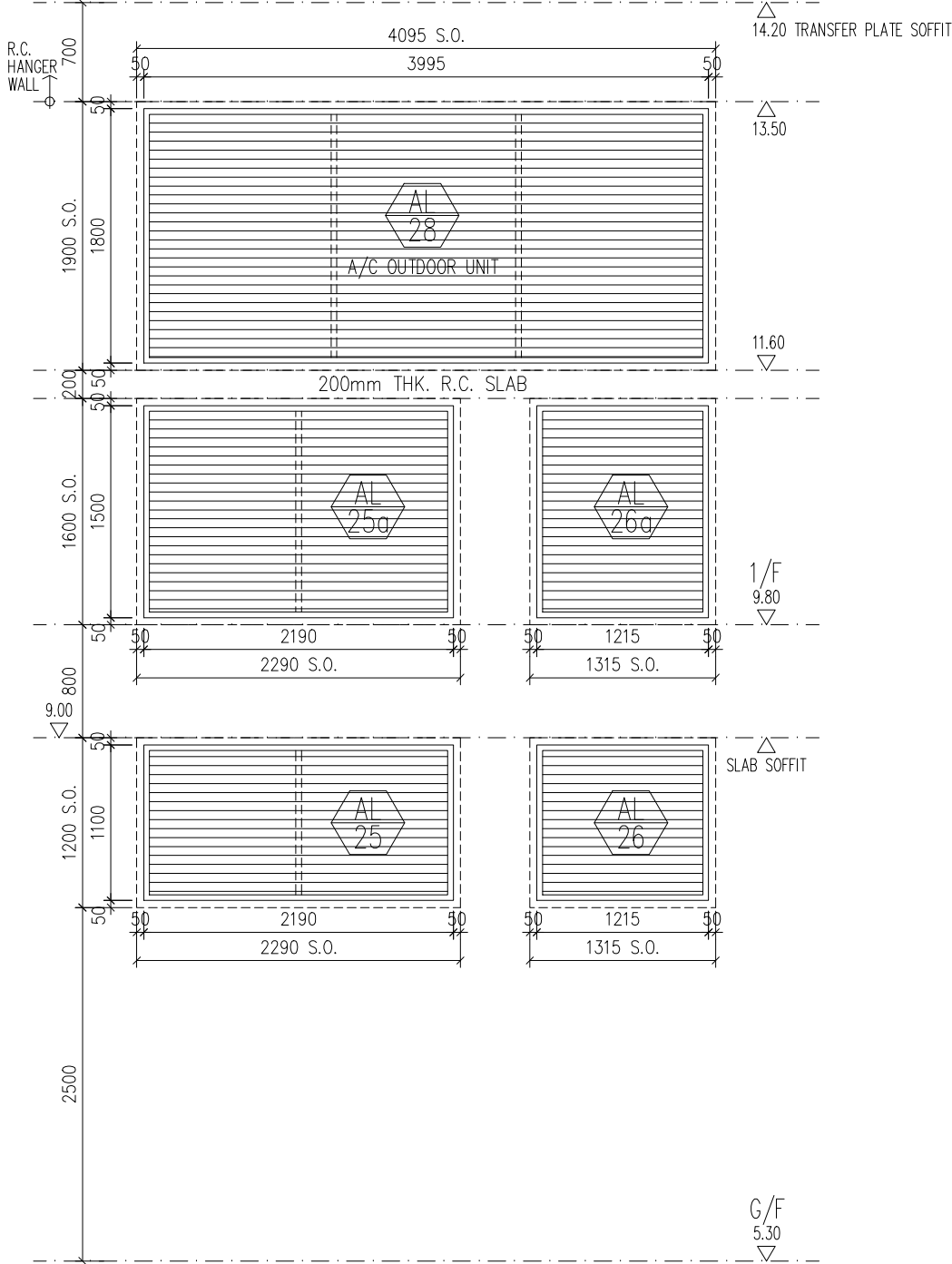
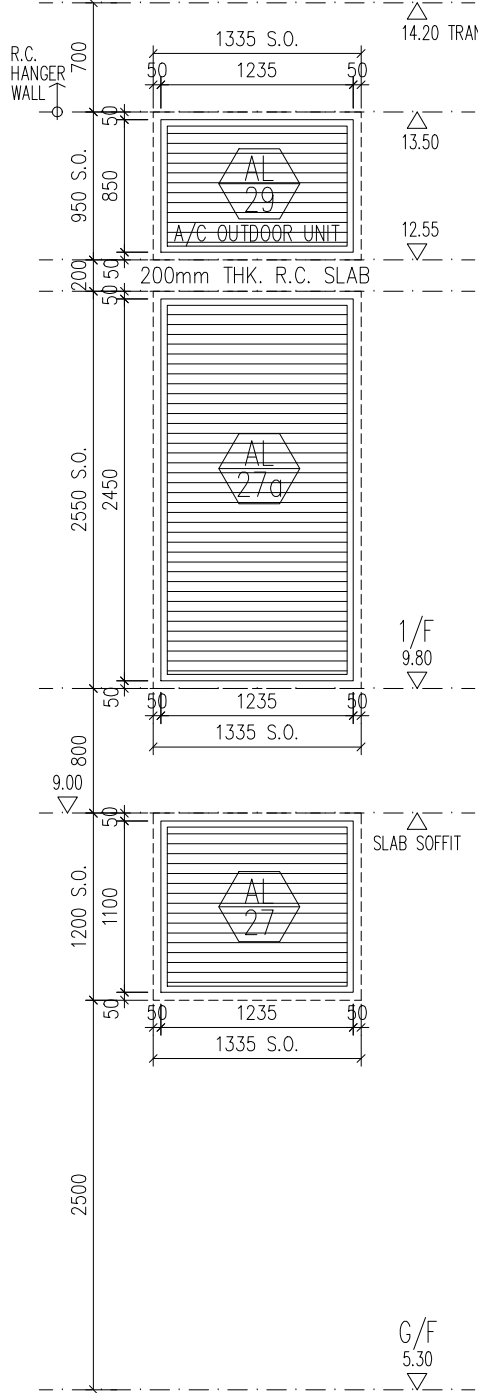

LOUVRE MARK	AL 01	AL 02	AL 03
ELEVATION (VIEWED FROM THE OUTSIDE)			
LOCATION	SHOP 01 (G/F)	BS-2 (F.R.S.) (G/F)	SHOP 02 (G/F)
PLATE	WEATHER PROOF ALUMINIUM LOUVRE BLADE W/. PVF2 COATING - (DARK GREY)		
SECTION	ALUMINIUM SECTION WITH PVF2 COATING - (DARK GREY)		
REMARK	3mm THK. ALUM. PLATE BACKING AND CUT-OUT OPENINGS VIA AIR DUCTS TO BE PROVIDED (NOTE : EXACT LOCATIONS REFER TO M.V.A.C. SHOP DWGS.)		
LOUVRE MARK	AL 04		AL 05
ELEVATION (VIEWED FROM THE OUTSIDE)			
LOCATION	SHOP 02 (G/F)		SHOP 01 (G/F)
PLATE	WEATHER PROOF ALUMINIUM LOUVRE BLADE W/. PVF2 COATING - (DARK GREY)		
SECTION	ALUMINIUM SECTION WITH PVF2 COATING - (DARK GREY)		
REMARK	3mm THK. ALUM. PLATE BACKING AND CUT-OUT OPENINGS VIA AIR DUCTS TO BE PROVIDED (NOTE : EXACT LOCATIONS REFER TO M.V.A.C. SHOP DWGS.)		

LOUVRE MARK	AL 06	AL 07	AL 08
ELEVATION (VIEWED FROM THE OUTSIDE)			
LOCATION	PROTECTED CORRIDOR (E.A.D. FOR LAV.) (G/F)	F.A.D. FOR B2 (G/F)	SHOP 03 (G/F)
PLATE	WEATHER PROOF ALUMINIUM LOUVRE BLADE W/. PVF2 COATING - (DARK GREY)		
SECTION	ALUMINIUM SECTION WITH PVF2 COATING - (DARK GREY)		
REMARK	3mm THK. ALUM. PLATE BACKING AND CUT-OUT OPENINGS VIA AIR DUCTS TO BE PROVIDED (NOTE : EXACT LOCATIONS REFER TO M.V.A.C. SHOP DWGS.)		
LOUVRE MARK	AL 09	AL 10	
ELEVATION (VIEWED FROM THE OUTSIDE)			
LOCATION	SHOP 03, SHOP 04, SHOP 05 & SHOP 06 (G/F)	F.A.D. FOR B1 (G/F)	
PLATE	WEATHER PROOF ALUMINIUM LOUVRE BLADE W/. PVF2 COATING - (DARK GREY)		
SECTION	ALUMINIUM SECTION WITH PVF2 COATING - (DARK GREY)		
REMARK	3mm THK. ALUM. PLATE BACKING AND CUT-OUT OPENINGS VIA AIR DUCTS TO BE PROVIDED (NOTE : EXACT LOCATIONS REFER TO M.V.A.C. SHOP DWGS.)		

LOUVRE MARK	AL 11	AL 12	AL 13
ELEVATION (VIEWED FROM THE OUTSIDE)			
LOCATION	E.A.D. (FACING COURTYARD) (G/F)	FRESH AIR DUCT FOR B2 (FACING COURTYARD) (G/F)	SHOP 06 (G/F)
PLATE	WEATHER PROOF ALUMINIUM LOUVRE BLADE W/. PVF2 COATING - (DARK GREY)		
SECTION	ALUMINIUM SECTION WITH PVF2 COATING - (DARK GREY)		
REMARK	3mm THK. ALUM. PLATE BACKING AND CUT-OUT OPENINGS VIA AIR DUCTS TO BE PROVIDED (NOTE : EXACT LOCATIONS REFER TO M.V.A.C. SHOP DWGS.)		
LOUVRE MARK	AL 14	AL 15	AL 16
ELEVATION (VIEWED FROM THE OUTSIDE)			
LOCATION	SHOP 07, SHOP 08 & SHOP 09 (G/F)	F.A.D. FOR B2 (G/F)	ACCESSIBLE TOILET (G/F)
PLATE	WEATHER PROOF ALUMINIUM LOUVRE BLADE W/. PVF2 COATING - (DARK GREY)		
SECTION	ALUMINIUM SECTION WITH PVF2 COATING - (DARK GREY)		
REMARK	3mm THK. ALUM. PLATE BACKING AND CUT-OUT OPENINGS VIA AIR DUCTS TO BE PROVIDED (NOTE : EXACT LOCATIONS REFER TO M.V.A.C. SHOP DWGS.)		

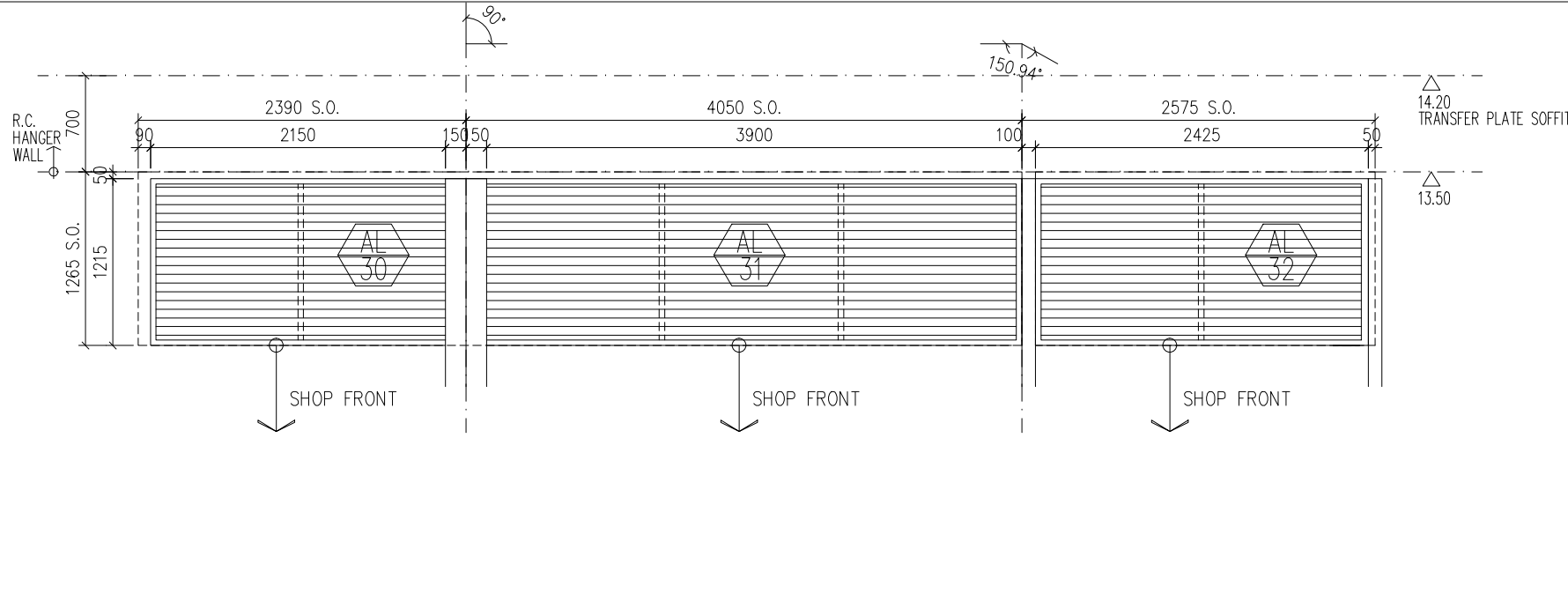
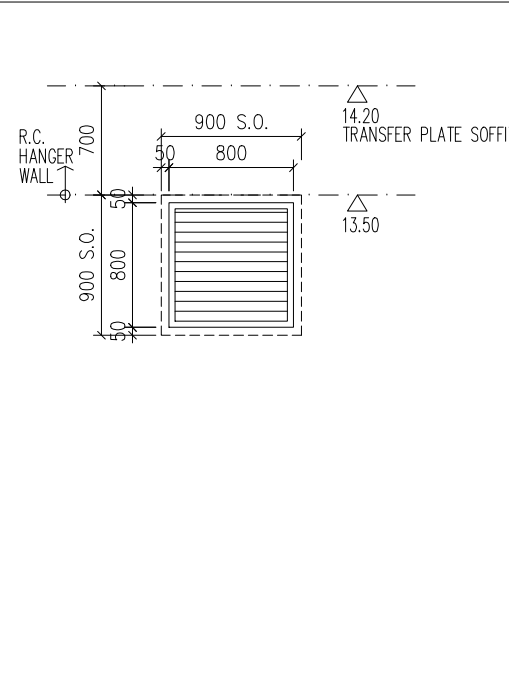
LOUVRE MARK	AL 17	AL 18	AL 19	AL 20
ELEVATION (VIEWED FROM THE OUTSIDE)				
LOCATION	F.A.D. FOR B2 (G/F)	SMOKE OUTLET S05 (G/F)	TOP VENT FOR BS-4 (G/F)	SMOKE OUTLET S06 (G/F)
PLATE	WEATHER PROOF ALUMINIUM LOUVRE BLADE W/. PVF2 COATING - (DARK GREY)			
SECTION	ALUMINIUM SECTION WITH PVF2 COATING - (DARK GREY)			
REMARK	3mm THK. ALUM. PLATE BACKING AND CUT-OUT OPENINGS VIA AIR DUCTS TO BE PROVIDED (NOTE : EXACT LOCATIONS REFER TO M.V.A.C. SHOP DWGS.)			
LOUVRE MARK	AL 21 AL 21a	AL 22 AL 22a	AL 23	AL 24
ELEVATION (VIEWED FROM THE OUTSIDE)				
LOCATION	EXHAUST FOR LAV. & P.A.U. (G/F F. LOBBY)	TOP VENT FOR BS-4 (G/F)	EXHAUST FOR E/M RM. (G/F)	EXHAUST FOR LAV. (G/F)
PLATE	WEATHER PROOF ALUMINIUM LOUVRE BLADE W/. PVF2 COATING - (DARK GREY)			
SECTION	ALUMINIUM SECTION WITH PVF2 COATING - (DARK GREY)			
REMARK	3mm THK. ALUM. PLATE BACKING AND CUT-OUT OPENINGS VIA AIR DUCTS TO BE PROVIDED (NOTE : EXACT LOCATIONS REFER TO M.V.A.C. SHOP DWGS.)			

LOUVRE MARK	   		 	
ELEVATION (VIEWED FROM THE OUTSIDE)				
LOCATION	EXHAUST AIR DUCT FOR B1 (G/F & 1/F)	A/C OUTDOOR UNIT (1/F)	EXHAUST AIR DUCT FOR B2 (G/F & 1/F)	A/C OUTDOOR UNIT (1/F)
PLATE	WEATHER PROOF ALUMINIUM LOUVRE BLADE W/. PVF2 COATING - (DARK GREY)			
SECTION	ALUMINIUM SECTION WITH PVF2 COATING - (DARK GREY)			
REMARK	3mm THK. ALUM. PLATE BACKING AND CUT-OUT OPENINGS VIA AIR DUCTS TO BE PROVIDED (NOTE : EXACT LOCATIONS REFER TO M.V.A.C. SHOP DWGS.)			

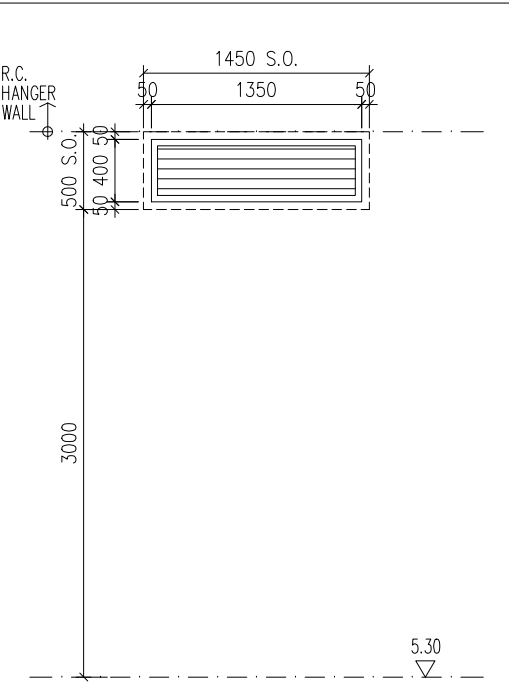
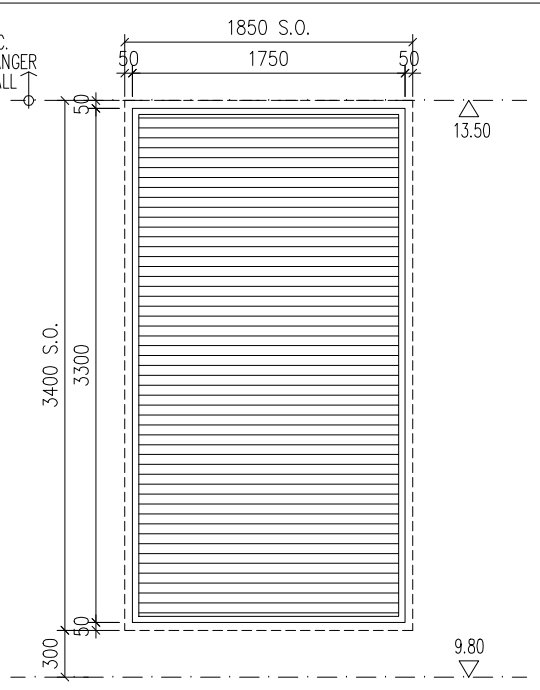
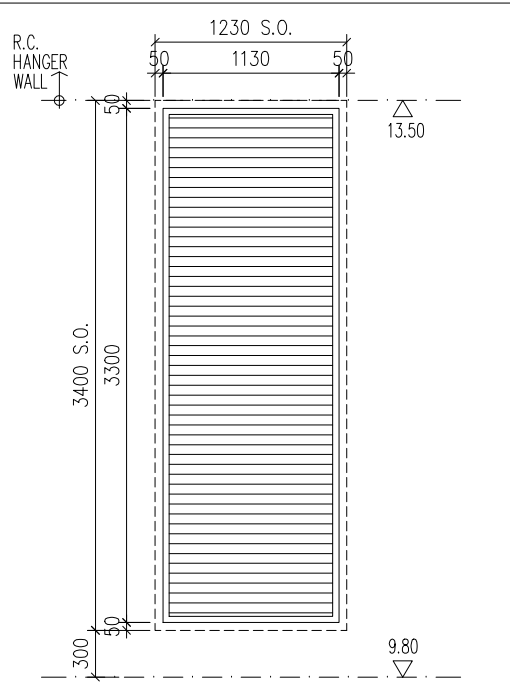
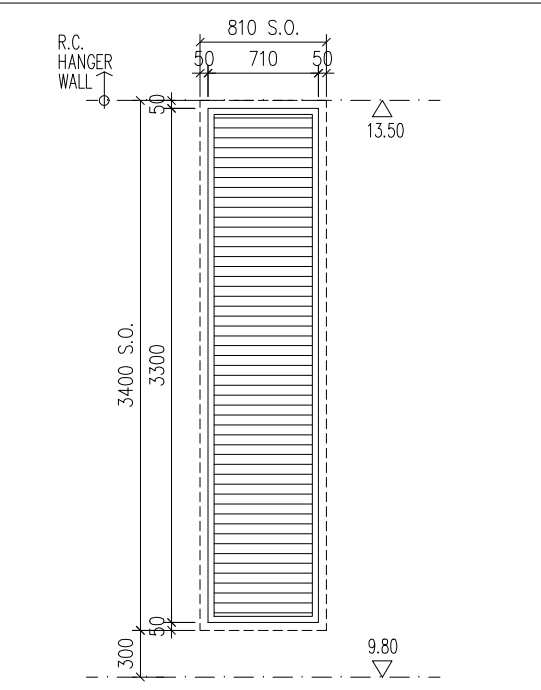
LOUVRE MARK				
ELEVATION (VIEWED FROM THE OUTSIDE)				
LOCATION	SECOND PEDESTRIAN WALKWAY (1/F)			LIFT VENT (1/F)
PLATE	WEATHER PROOF ALUMINIUM LOUVRE BLADE W/. PVF2 COATING - (DARK GREY)			
SECTION	ALUMINIUM SECTION WITH PVF2 COATING - (DARK GREY)			
REMARK	3mm THK. ALUM. PLATE BACKING AND CUT-OUT OPENINGS VIA AIR DUCTS TO BE PROVIDED (NOTE : EXACT LOCATIONS REFER TO M.V.A.C. SHOP DWGS.)			
LOUVRE MARK				
ELEVATION (VIEWED FROM THE OUTSIDE)				
LOCATION	EXHAUST FOR LAV. (1/F)	FRESH AIR DUCT FOR B2 (1/F)	FRESH AIR DUCT FOR B1 (1/F)	EXHAUST FOR E/M RM. (1/F)
PLATE	WEATHER PROOF ALUMINIUM LOUVRE BLADE W/. PVF2 COATING - (DARK GREY)			
SECTION	ALUMINIUM SECTION WITH PVF2 COATING - (DARK GREY)			
REMARK	3mm THK. ALUM. PLATE BACKING AND CUT-OUT OPENINGS VIA AIR DUCTS TO BE PROVIDED (NOTE : EXACT LOCATIONS REFER TO M.V.A.C. SHOP DWGS.)			

LOUVRE MARK	AL 38		AL 39	
ELEVATION (VIEWED FROM THE OUTSIDE)				
LOCATION	EXHAUST AIR DUCT FOR B2, EXHAUST FOR LAV & LIFT VENT (1/F)		EXHAUST FOR LAV. (1/F)	
PLATE	WEATHER PROOF ALUMINIUM LOUVRE BLADE W/. PVF2 COATING – (DARK GREY)			
SECTION	ALUMINIUM SECTION WITH PVF2 COATING – (DARK GREY)			
REMARK	3mm THK. ALUM. PLATE BACKING AND CUT-OUT OPENINGS VIA AIR DUCTS TO BE PROVIDED (NOTE : EXACT LOCATIONS REFER TO M.V.A.C. SHOP DWGS.)			
LOUVRE MARK	AL 40		AL 41	
ELEVATION (VIEWED FROM THE OUTSIDE)				
LOCATION	EXHAUST AIR DUCT FOR B1 (1/F)		EXHAUST AIR DUCT FOR B1 (1/F POOL MAINTENANCE SPACE))	
PLATE	WEATHER PROOF ALUMINIUM LOUVRE BLADE W/. PVF2 COATING – (DARK GREY)			
SECTION	ALUMINIUM SECTION WITH PVF2 COATING – (DARK GREY)			
REMARK	3mm THK. ALUM. PLATE BACKING AND CUT-OUT OPENINGS VIA AIR DUCTS TO BE PROVIDED (NOTE : EXACT LOCATIONS REFER TO M.V.A.C. SHOP DWGS.)			

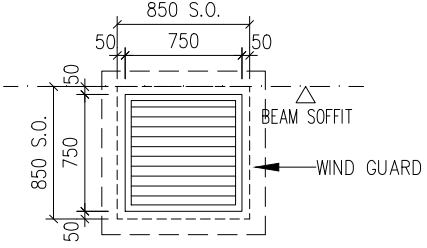
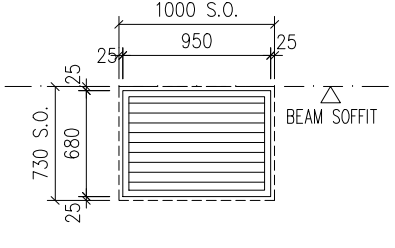
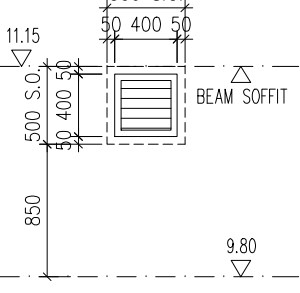
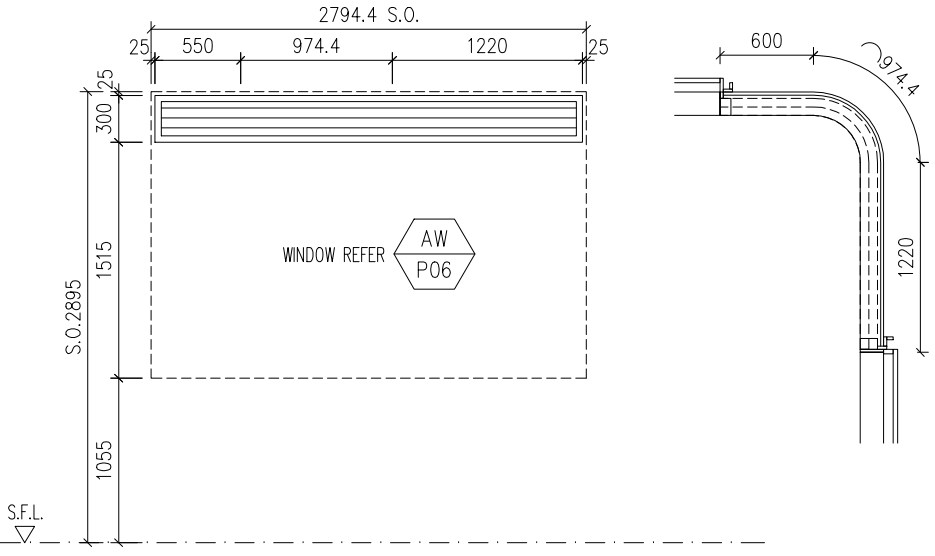
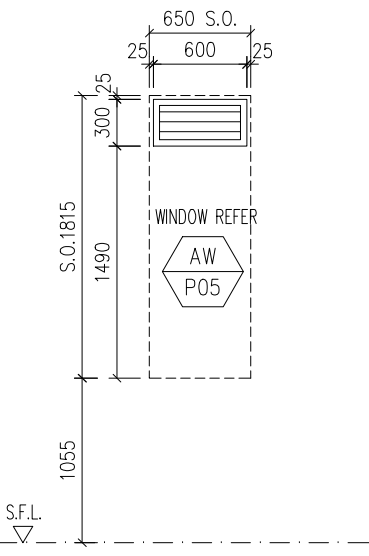
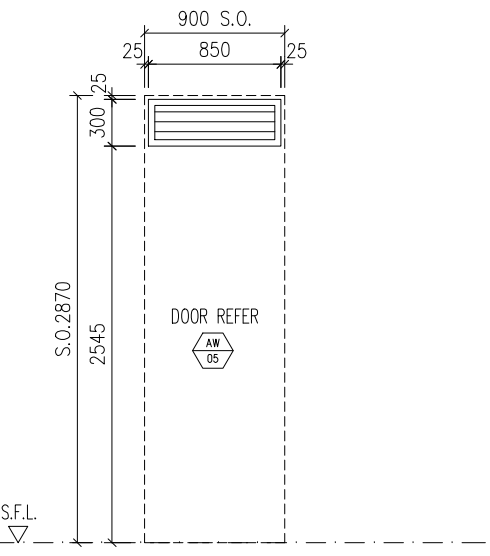
LOUVRE MARK	AL 42	AL 43	AL 44a	
ELEVATION (VIEWED FROM THE OUTSIDE)				
LOCATION	LIFT MACHINE ROOM (TOWER)	WATER FEATURE PLANT ROOM AT YELLOW AREA STAIRCASE AT R/F	EXHAUST FLUE APERTURE FOR TOWN GAS (1/F)	
PLATE	WEATHER PROOF ALUMINIUM LOUVRE BLADE W/. PVF2 COATING – (DARK GREY)			
SECTION	ALUMINIUM SECTION WITH PVF2 COATING – (DARK GREY)			
REMARK	3mm THK. ALUM. PLATE BACKING AND CUT-OUT OPENINGS VIA AIR DUCTS TO BE PROVIDED (NOTE : EXACT LOCATIONS REFER TO M.V.A.C. SHOP DWGS.)			
LOUVRE MARK	AL 44	AL 45	AL 46	
ELEVATION (VIEWED FROM THE OUTSIDE)				
LOCATION	SECURITY KIOSK AT YELLOW AREA			
PLATE	WEATHER PROOF ALUMINIUM LOUVRE BLADE W/. PVF2 COATING – (DARK GREY)			
SECTION	ALUMINIUM SECTION WITH PVF2 COATING – (DARK GREY)			
REMARK	3mm THK. ALUM. PLATE BACKING AND CUT-OUT OPENINGS VIA AIR DUCTS TO BE PROVIDED (NOTE : EXACT LOCATIONS REFER TO M.V.A.C. SHOP DWGS.)			

LOUVRE MARK	AL 45a	AL 46a	AL 47	AL 49
ELEVATION (VIEWED FROM THE OUTSIDE)				
LOCATION	EXHAUST FLUE APERTURE FOR TOWN GAS (1/F)	EXHAUST AIR DUCT FOR FILTRATION PLANT ROOM (1/F)	NATURAL VENTILATION FOR TOWN GAS SYSTEM (1/F)	EXHAUST AIR DUCT FOR B2 (1/F)
PLATE	WEATHER PROOF ALUMINIUM LOUVRE BLADE W/. PVF2 COATING (DARK GREY)			
SECTION	ALUMINIUM SECTION WITH PVF2 COATING - (DARK GREY)			
REMARK	3mm THK. ALUM. PLATE BACKING AND CUT-OUT OPENINGS VIA AIR DUCTS TO BE PROVIDED (NOTE : EXACT LOCATIONS REFER TO M.V.A.C. SHOP DWGS.)			
LOUVRE MARK	AL 50	AL 51	AL 52	AL 53
ELEVATION (VIEWED FROM THE OUTSIDE)				
LOCATION	EXHAUST AIR DUCT FOR B1 (1/F)	EXHAUST AIR DUCT FOR E/M ROOM (1/F)	EXHAUST AIR DUCT FOR TOWN GAS (1/F)	EXHAUST AIR DUCT FOR E/M RM. (1/F LIFT LOBBY)
PLATE	WEATHER PROOF ALUMINIUM LOUVRE BLADE W/. PVF2 COATING - (DARK GREY)			
SECTION	ALUMINIUM SECTION WITH PVF2 COATING - (DARK GREY)			
REMARK	3mm THK. ALUM. PLATE BACKING AND CUT-OUT OPENINGS VIA AIR DUCTS TO BE PROVIDED (NOTE : EXACT LOCATIONS REFER TO M.V.A.C. SHOP DWGS.)			

LOUVRE MARK	AL 54	AL 55	AL 56	AL 57
ELEVATION (VIEWED FROM THE OUTSIDE)				
LOCATION	EXHAUST AIR DUCT FOR FILTRATION PLANT. RM. (1/F)	FRESH AIR DUCT FOR TOWN GAS (1/F)	LIFT VENT (1/F)	EXHAUST AIR DUCT FOR PAU ROOM (1/F)
PLATE	WEATHER PROOF ALUMINIUM LOUVRE BLADE W/. PVF2 COATING - (DARK GREY)			
SECTION	ALUMINIUM SECTION WITH PVF2 COATING - (DARK GREY)			
REMARK	3mm THK. ALUM. PLATE BACKING AND CUT-OUT OPENINGS VIA AIR DUCTS TO BE PROVIDED (NOTE : EXACT LOCATIONS REFER TO M.V.A.C. SHOP DWGS.)			
LOUVRE MARK	AL 58	AL 59	AL 60 AL 60a	AL 61
ELEVATION (VIEWED FROM THE OUTSIDE)				
LOCATION	EXHAUST AIR DUCT FOR TBE ROOM (1/F)	EXHAUST AIR DUCT FOR TOWN GAS (1/F)	EXHAUST AIR DUCT FOR E/M ROOM (1/F CARETAKER'S QUARTER)	EXHAUST AIR DUCT FOR E/M ROOM (1/F MANAGEMENT'S ACCESSIBLE TOILET)
PLATE	WEATHER PROOF ALUMINIUM LOUVRE BLADE W/. PVF2 COATING - (DARK GREY)			
SECTION	ALUMINIUM SECTION WITH PVF2 COATING - (DARK GREY)			
REMARK	3mm THK. ALUM. PLATE BACKING AND CUT-OUT OPENINGS VIA AIR DUCTS TO BE PROVIDED (NOTE : EXACT LOCATIONS REFER TO M.V.A.C. SHOP DWGS.)			

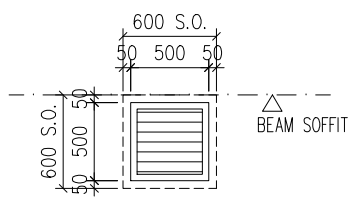
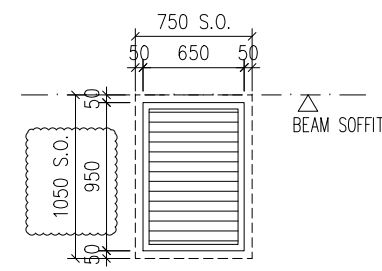
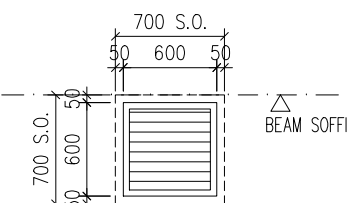
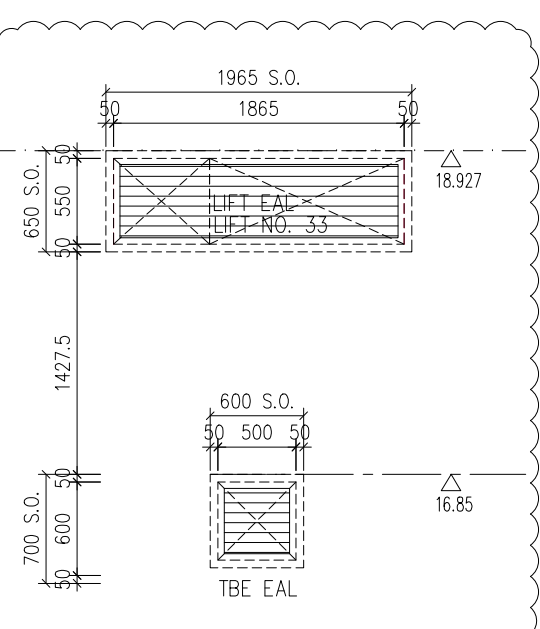
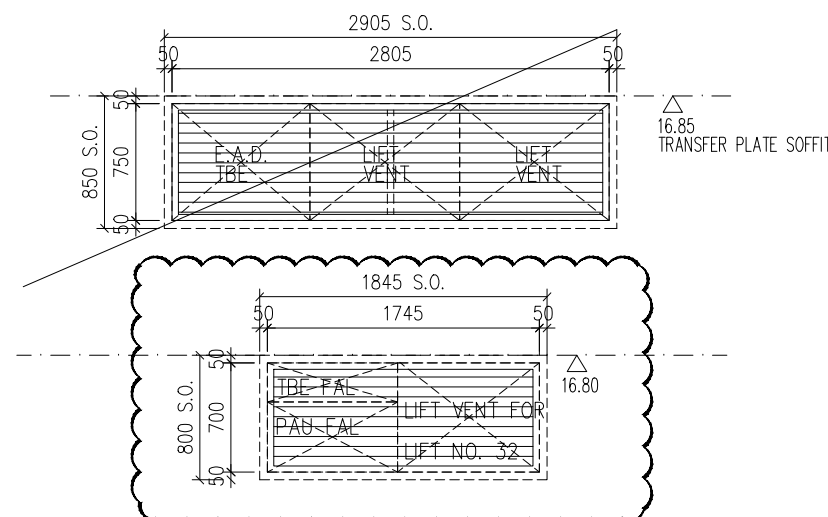
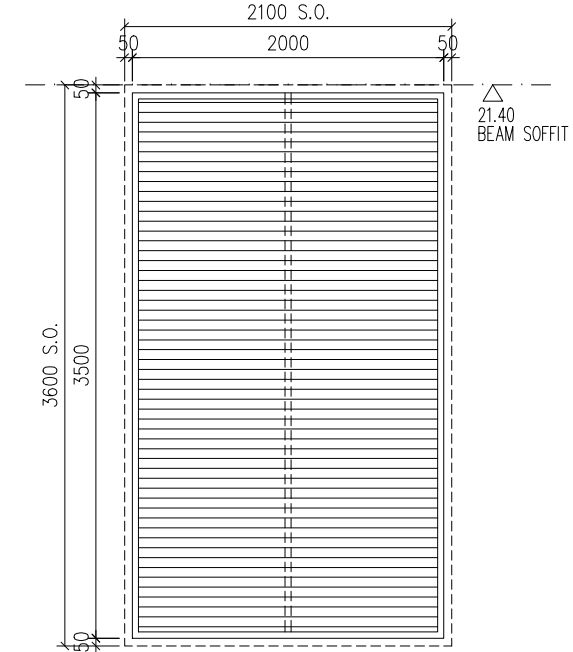
LOUVRE MARK	AL 62	AL 63	AL 64	AL 65
ELEVATION (VIEWED FROM THE OUTSIDE)				
LOCATION	EXHAUST AIR DUCT FOR TOWN GAS (1/F) FAN ROOM (2/F & 3/F)	LIFT VENT (G/F & 1/F)	TOP VENT OF STAIRCASE E/M ROOM (AT TOWER ROOF)	EXHAUST AIR DUCT FOR TBE ROOM & LIFT VENT (2/F)
PLATE	WEATHER PROOF ALUMINIUM LOUVRE BLADE W/. PVF2 COATING - (DARK GREY)			
SECTION	ALUMINIUM SECTION WITH PVF2 COATING - (DARK GREY)			
REMARK	3mm THK. ALUM. PLATE BACKING AND CUT-OUT OPENINGS VIA AIR DUCTS TO BE PROVIDED (NOTE : EXACT LOCATIONS REFER TO M.V.A.C. SHOP DWGS.)			
LOUVRE MARK	AL 66		AL 67	
ELEVATION (VIEWED FROM THE OUTSIDE)				
LOCATION	EXHAUST AIR DUCT FOR TBE ROOM & LIFT VENT (2/F)		EXHAUST AIR DUCT FOR WATER PUMP ROOM (2/F)	
PLATE	WEATHER PROOF ALUMINIUM LOUVRE BLADE W/. PVF2 COATING - (DARK GREY)			
SECTION	ALUMINIUM SECTION WITH PVF2 COATING - (DARK GREY)			
REMARK	3mm THK. ALUM. PLATE BACKING AND CUT-OUT OPENINGS VIA AIR DUCTS TO BE PROVIDED (NOTE : EXACT LOCATIONS REFER TO M.V.A.C. SHOP DWGS.)			

LOUVRE MARK	AL 68		AL 69		AL 70			
ELEVATION (VIEWED FROM THE OUTSIDE)								
LOCATION	EXHAUST AIR DUCT FOR TBE ROOM (3/F)		EXHAUST AIR DUCT FOR TBE ROOM (3/F)		EXHAUST AIR DUCT FOR TBE ROOM (3/F)			
PLATE	WEATHER PROOF ALUMINIUM LOUVRE BLADE W/. PVF2 COATING - (DARK GREY)							
SECTION	ALUMINIUM SECTION WITH PVF2 COATING - (DARK GREY)							
REMARK	3mm THK. ALUM. PLATE BACKING AND CUT-OUT OPENINGS VIA AIR DUCTS TO BE PROVIDED (NOTE : EXACT LOCATIONS REFER TO M.V.A.C. SHOP DWGS.)							
LOUVRE MARK	AL 71		AL 72		AL 73		AL 74	
ELEVATION (VIEWED FROM THE OUTSIDE)								
LOCATION	FRESH AIR DUCT FOR B2 (FACING COURTYARD) (G/F)		TBE ROOM (5) (2/F)		TBE ROOM (1) (3/F)		TBE ROOM (1) (3/F)	
PLATE	WEATHER PROOF ALUMINIUM LOUVRE BLADE W/. PVF2 COATING - (DARK GREY)							
SECTION	ALUMINIUM SECTION WITH PVF2 COATING - (DARK GREY)							
REMARK	3mm THK. ALUM. PLATE BACKING AND CUT-OUT OPENINGS VIA AIR DUCTS TO BE PROVIDED (NOTE : EXACT LOCATIONS REFER TO M.V.A.C. SHOP DWGS.)							

LOUVRE MARK	AL 75	AL 76	AL 77	AL 78
ELEVATION (VIEWED FROM THE OUTSIDE)				
LOCATION	EXHAUST AIR DUCT FOR TBE ROOM (3/F)	EXHAUST AIR DUCT AT IRRIGATION & CLEANSING WATER PUMP ROOM (2/F)	EXHAUST AIR DUCT FOR LAV. (1/F R.R.F.)	EXHAUST AIR DUCT & FRESH AIR FOR LAV. (1/F R.R.F.)
PLATE	WEATHER PROOF ALUMINIUM LOUVRE BLADE W/. PVF2 COATING - (DARK GREY)			
SECTION	ALUMINIUM SECTION WITH PVF2 COATING - (DARK GREY)			
REMARK	3mm THK. ALUM. PLATE BACKING AND CUT-OUT OPENINGS VIA AIR DUCTS TO BE PROVIDED (NOTE : EXACT LOCATIONS REFER TO M.V.A.C. SHOP DWGS.)			
LOUVRE MARK	AL 79	AL 80	AL 81	AL 82
ELEVATION (VIEWED FROM THE OUTSIDE)				
LOCATION	EXHAUST AIR DUCT (3/F PIPE DUCT ROOM)	EXHAUST AIR DUCT (3/F PIPE DUCT ROOM)	EXHAUST AIR DUCT (1/F POTABLE WATER PUMP ROOM)	EXHAUST AIR DUCT FOR LIFT VENT (UNDER THE FOOTBRIDGE)
PLATE	WEATHER PROOF ALUMINIUM LOUVRE BLADE W/. PVF2 COATING - (DARK GREY)			
SECTION	ALUMINIUM SECTION WITH PVF2 COATING - (DARK GREY)			
REMARK	3mm THK. ALUM. PLATE BACKING AND CUT-OUT OPENINGS VIA AIR DUCTS TO BE PROVIDED (NOTE : EXACT LOCATIONS REFER TO M.V.A.C. SHOP DWGS.)			

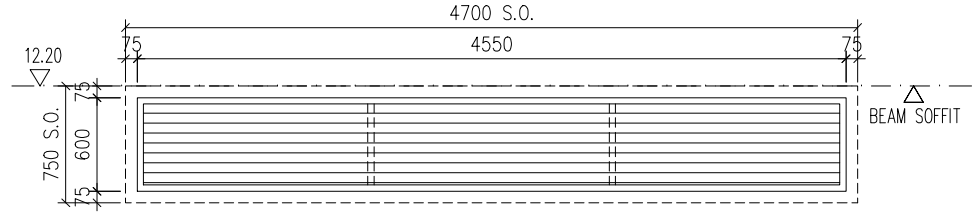
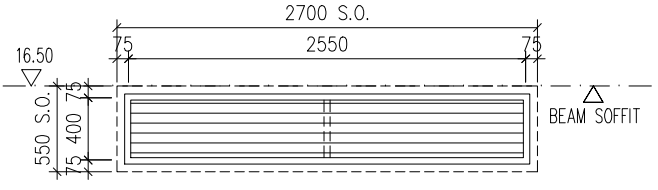
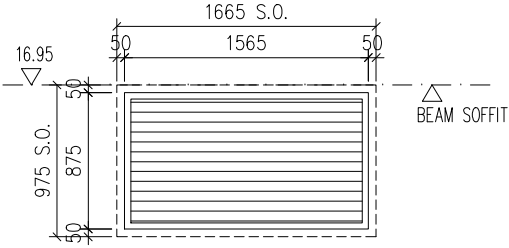
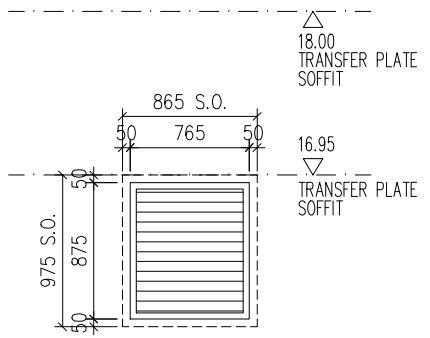
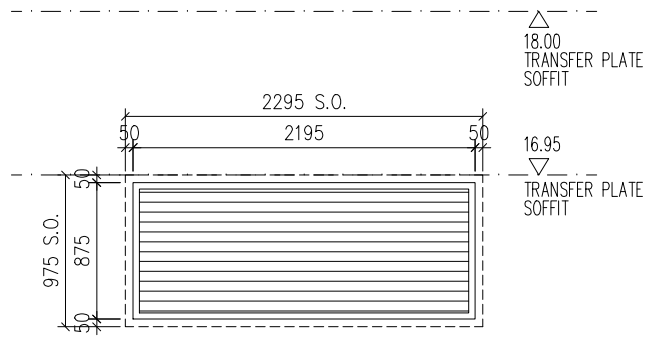
LOUVRE MARK	AL 83		AL 84	
ELEVATION (VIEWED FROM THE OUTSIDE)				
LOCATION	EXHAUST AIR DUCT FOR B2 (UNDER THE FOOTBRIDGE)		EXHAUST AIR DUCT (FOOTBRIDGE)	
PLATE	WEATHER PROOF ALUMINIUM LOUVRE BLADE W/. PVF2 COATING - (DARK GREY)			
SECTION	ALUMINIUM SECTION WITH PVF2 COATING - (DARK GREY)			
REMARK	3mm THK. ALUM. PLATE BACKING AND CUT-OUT OPENINGS VIA AIR DUCTS TO BE PROVIDED (NOTE : EXACT LOCATIONS REFER TO M.V.A.C. SHOP DWGS.)			
LOUVRE MARK	AL 85	AL 86	AL 87	
ELEVATION (VIEWED FROM THE OUTSIDE)				
LOCATION	FRESH AIR DUCT (2/F A/C ROOM)	FRESH AIR DUCT (2/F A/C ROOM)	EXHAUST AIR DUCT (2/F A/C ROOM)	
PLATE	WEATHER PROOF ALUMINIUM LOUVRE BLADE W/. PVF2 COATING - (DARK GREY)			
SECTION	ALUMINIUM SECTION WITH PVF2 COATING - (DARK GREY)			
REMARK	3mm THK. ALUM. PLATE BACKING AND CUT-OUT OPENINGS VIA AIR DUCTS TO BE PROVIDED (NOTE : EXACT LOCATIONS REFER TO M.V.A.C. SHOP DWGS.)			

LOUVRE MARK	ML 01	ML 02	ML 03	ML 04
ELEVATION (VIEWED FROM THE OUTSIDE)				
LOCATION	F.S. WATER PUMP ROOM AT B2/F (FOR TOWERS 6) FILTRATION PLANT ROOM AT B1/F (FOR OUTDOOR SWIMMING POOL)	POTABLE & FLUSHING WATER PUMP ROOM AT B2/F (COMMERCIAL) F.S. WATER PUMP ROOM AT B1/F (FOR TOWERS 5)	SPRINKLER WATER PUMP ROOM AT B2/F (FOR TOWERS 3&6 OPEN KITCHEN) POTABLE & FLUSHING WATER PUMP ROOM AT B1/F (FOR TOWERS 6&7) F.S. WATER PUMP ROOM AT B1/F (FOR TOWERS 5)	SPRINKLER WATER PUMP ROOM AT B2/F (FOR PODIUM)
PLATE	WEATHER PROOF G.M.S. LOUVRE BLADE W/. POWDER COATING – (DARK GREY)			
SECTION	G.M.S. SECTION WITH POWER COATING – (DARK GREY)			
REMARK	3MM THK. G.M.S. PLATE BACKING WITH –/120/120 F.R. SEPARATION BEHIND LOUVER PANEL ONLY ON FIRE RATED WALL AND ANY CUT-OUT OPENINGS VIA AIR DUCTS TO BE PROVIDED WITH FIRE DAMPERS (NOTE : EXACT LOCATIONS REFER TO LAYOUT PLANS AND M.V.A.C. SHOP DWGS.)			
LOUVRE MARK	ML 05	ML 06	ML 07	ML 08
ELEVATION (VIEWED FROM THE OUTSIDE)				
LOCATION	MASTER WATER METER ROOM AT B1/F F.S. WATER PUMP ROOM AT B1/F (FOR TOWERS 1,2&5)	POTABLE & FLUSHING WATER PUMP ROOM AT B1/F (FOR TOWERS 1,2,8&L) SPRINKLER WATER PUMP ROOM AT B1/F (FOR TOWERS 8 OPEN KITCHEN)	FIRE HYDRANT WATER TANK & PUMP ROOM AT B1/F	SPRINKLER WATER PUMP ROOM AT B1/F (FOR TOWERS 6 OPEN KITCHEN)
PLATE	WEATHER PROOF G.M.S. LOUVRE BLADE W/. POWDER COATING – (DARK GREY)			
SECTION	G.M.S. SECTION WITH POWER COATING – (DARK GREY)			
REMARK	3MM THK. G.M.S. PLATE BACKING WITH –/120/120 F.R. SEPARATION BEHIND LOUVER PANEL ONLY ON FIRE RATED WALL AND ANY CUT-OUT OPENINGS VIA AIR DUCTS TO BE PROVIDED WITH FIRE DAMPERS (NOTE : EXACT LOCATIONS REFER TO LAYOUT PLANS AND M.V.A.C. SHOP DWGS.)			

LOUVRE MARK	ML 09		ML 10	
ELEVATION (VIEWED FROM THE OUTSIDE)				
LOCATION	REFUSE STORAGE & MATERIAL RECOVERY CHAMBER AT B1/F		TOWER 2, 3, 6 & 7 UPPER ROOF : GENSET ROOM	
PLATE	WEATHER PROOF G.M.S. LOUVRE BLADE W/. POWDER COATING - (DARK GREY)		WEATHER PROOF S.S. 316L LOUVRE BLADE WITH POWDER COATING - (DARK GREY)	
SECTION	G.M.S. SECTION WITH POWER COATING - (DARK GREY)		S.S. 316L SECTION WITH POWDER COATING - (DARK GREY)	
REMARK	3MM THK. G.M.S. PLATE BACKING WITH -/120/120 F.R. SEPARATION BEHIND LOUVRE PANEL ONLY ON FIRE RATED WALL AND ANY CUT-OUT OPENINGS VIA AIR DUCTS TO BE PROVIDED WITH FIRE DAMPERS (NOTE : EXACT LOCATIONS REFER TO LAYOUT PLANS AND M.V.A.C. SHOP DWGS.)			
LOUVRE MARK	ML 11	ML 12	ML 13	ML 14
ELEVATION (VIEWED FROM THE OUTSIDE)				
LOCATION	TRANSFORMER ROOM (C) AT 3/F TRANSFORMER ROOM (B) AT 2/F H.V. SWITCH ROOM (A) AT G/F	TRANSFORMER DELIVERY ROUTE & CABLE RISER ROOM AT G/F	TRANSFORMER ROOM (C) AT 3/F TRANSFORMER ROOM (B) AT 2/F H.V. SWITCH ROOM (A) AT G/F	H.V. SWITCH ROOM (A) AT G/F
PLATE	WEATHER PROOF S.S. 316L LOUVRE BLADE WITH POWDER COATING - (DARK GREY)			
SECTION	S.S. 316L SECTION WITH POWDER COATING - (DARK GREY)			
REMARK	3MM THK. S.S. 316L PLATE BACKING WITH -/120/120 F.R.R. SEPARATION BEHIND LOUVRE PANEL ONLY ON FIRE RATED WALL AND ANY CUT-OUT OPENINGS VIA AIR DUCTS TO BE PROVIDED WITH FIRE DAMPERS (NOTE : EXACT LOCATIONS REFER TO LAYOUT PLANS AND M.V.A.C. SHOP DWGS.)			