

工程指示 / 要求簡箋 ENGINEER INSTRUCTIONS(E.I.)

工程指示編號:	EI- 7852	修改版本:	-
	HK-0990		
工程編號:	J 856	工程名稱:	天榮站
收件人:	生統/Maggie	發件人:	Iris
工程項目:	T2+T3 Spare玻璃	日期:	28/05/2024

<input checked="" type="checkbox"/> 原合約工程包	<input type="checkbox"/> 原合約工程加 / 減賬 QT-	<input type="checkbox"/> 新工程報價 QT-
--	--	------------------------------------

信件批核號碼/圖紙參考編號:	批核模具圖紙編號:
客戶指示附件:	管理內部批簽署:

<input type="checkbox"/> 初步鋁料 B.M.	<input type="checkbox"/> 加工拆圖, 然後生產	<input type="checkbox"/> 尺寸表
<input type="checkbox"/> 正式鋁料 B.M.	<input type="checkbox"/> 技術上資料/指示	<input type="checkbox"/> 報價
<input type="checkbox"/> 配件 B.M.	<input type="checkbox"/> 樣辦或貨品說明書	<input type="checkbox"/> 分判合約
<input type="checkbox"/> 其他:		

內容: T2+T3 Spare玻璃
根據合約General Specification Clause 1.8要求以及經28/5/2024會議確立, 按照附頁玻璃明細及加工圖生產及提供Spare玻璃
要做鋼化, 需做熱浸, 新鴻基COW T1(100%)
按照1.5噸標準出貨, 請提供packing list給新鴻基確認出貨包裝
完成上列要求日期: 15/07/2024

國內

<input type="checkbox"/> 生產技術總監	<input type="checkbox"/> 連附件	<input checked="" type="checkbox"/> 技術部	<input checked="" type="checkbox"/> 連附件	<input type="checkbox"/> 生產部	<input type="checkbox"/> 連附件
<input type="checkbox"/> 採購部	<input type="checkbox"/> 連附件	<input checked="" type="checkbox"/> 生產統籌部	<input checked="" type="checkbox"/> 連附件	<input type="checkbox"/> 報關組	<input type="checkbox"/> 連附件
<input type="checkbox"/> 質檢部	<input type="checkbox"/> 連附件	<input type="checkbox"/> 會計部	<input type="checkbox"/> 連附件	<input type="checkbox"/> 機械設計部	<input type="checkbox"/> 連附件
<input type="checkbox"/> 香港辦	<input type="checkbox"/> 連附件	<input type="checkbox"/> 其他:			

香港

<input type="checkbox"/> 行政部	<input type="checkbox"/> 連附件	<input type="checkbox"/> 會計部	<input type="checkbox"/> 連附件	<input type="checkbox"/> 統籌部	<input type="checkbox"/> 連附件	<input type="checkbox"/> 工程部	<input type="checkbox"/> 連附件
<input checked="" type="checkbox"/> 採購部	<input checked="" type="checkbox"/> 連附件	<input type="checkbox"/> QS部	<input type="checkbox"/> 連附件	<input checked="" type="checkbox"/> 地盤管理	<input checked="" type="checkbox"/> 連附件	<input type="checkbox"/> 維修部	<input type="checkbox"/> 連附件

*發件人簽署: Iris	*組別成員批核簽署:
傳遞編號:	項目經理簽署:

幕牆			玻璃尺寸			% spare for handover 1.5% / not less than 1pc.
Glass type	thk.	Item	T2+T3 Qty.	寬度 (W mm)	高度 (H mm)	
GL1: 8mm Heat Strengthen + 12AIR+10mm Tempered Glass(Vision)	30	1	456	614	840	7
		2	5	1551.5	2005	1
		3	111	661	1105	2
		4	113	661	840	2
		5	74	1321.5	2005	1
		6	74	1686.5	2005	1
		7	2	614	1405	1
		8	2	1834	2005	1
		9	4	849	840	1
		10	2	1371.5	2005	1
		11	454	614	1105	7
		12	4	849	1105	1
		13	2	661	1405	1
		14	74	1911	2005	2
		15	37	921.5	2005	2
		16	37	1569	2005	2
		17	37	729	2005	2
		18	2	884	840	1
		19	1	1284	2005	1
		20	2	814	840	1
		21	1	1171.5	2005	1
		22	37	761	1105	2
		23	37	561	1105	2
		24	2	884	1105	1
		25	2	814	1105	1
		26	37	1678.5	2005	2
27	37	761	840	2		
28	37	561	840	2		
29	74	1811	2005	2		
30	1	1911	2305	1		
31	3	2164	2005	1		
32	1	1811	2305	1		
33	456	570	122	7		
34	113	497	122	2		
35	4	805	122	1		
36	37	597	122	2		
37	37	397	122	2		
38	2	770	122	1		
39	2	840	122	1		
GL1a: 8mm Heat Strengthen + 12AIR+12mm Tempered Glass(Vision)	32					
GL5: 12mm Tempered Glass(PROTECTIVE BARRIER)	12					
			2413		71	
Including spandrel			3524			

鋁窗			玻璃尺寸			% spare for handover 1.5% / not less than 1pc.
Glass type	thk.	Item	T2+T3 Qty.	寬度 (W mm)	高度 (H mm)	
8mmHS+12mm AIR GAP+10mmTP THK. I.G.U.	30	1	1192	452	544.5	18
		2	970	452	774.5	15
		3	1201	410	1720	18
		4	75	660	1720	2
		5	449	810	1950	7
		6	487	610	1950	7
		7	75	352	544.5	2
		8	74	462	544.5	2
		9	2	667	774.5	1
		10	2	982	774.5	1
		11	37	725	1950	2
		12	37	430	1950	2
		13	113	790	1910	2
		14	150	452	754.5	2
		15	38	590	1910	2
		16	11	437	759.5	2
		17	1	920	1930	1
		18	1	437	330	1
		19	1	945	1930	1
		20	1	1095	1930	1
		21	1	495	1930	1
		22	7	795	1930	1
		23	3	441	764	1
		24	1	979	1934	1
		25	1	1129	1934	1
		26	1	829	1934	1
8mmHS+12mm AIR GAP+10mm CLEAR TEMPERED ACID ETCHED THK. (FROSTED ON #3)I.G.U	30	27	9	452	544.5	1
28	3	452	774.5	1		
8mmHS+12mm AIR GAP+8mmTP THK. I.G.U.	28	29	2362	450	1064.5	35
30	75	350	1064.5	2		
31	38	460	1064.5	2		
32	2	665	1064.5	1		
33	2	980	1064.5	1		
34	12	435	1059.5	2		
35	3	439	1063.5	1		
36	2	648.2	2262.2	1		
37	2	661.2	2262.2	1		
38	2	855	2262	1		
39	37	450	1080	2		
10mm THK. CRYSTAL GRAY TEMPERED GLASS(FOR KIT & ST)	10	40	76	430	1040	2
41	39	320	1040	2		
42	10	450	1040	2		
43	6	420	1040	1		
44	2	500	1040	1		
45	117	420	1040	2		
46	75	320	1040	2		
47	2	570	1040	1		
10mm THK. CRYSTAL TEMPERED ACID ETCHED GLASS(FOR BATH)	10	48	1	462	544.5	1
8mmHS+12mm AIR GAP+10mmTP CLEAR TEMPERED ACID ETCHED THK. I.G.U.	30	49	1	452	754.5	1
			7809		161	

趟門			玻璃尺寸			% spare for handover 1.5% / not less than 1pc.
Glass type	thk.	Item	T2+T3 Qty.	寬度 (W mm)	高度 (H mm)	
8mm THK.CLEAR HS GLASS+12AIR GAP+8mm THK.CLEAR TP GLASS	28	1	2206	738.5	2131	33
		2	255	696	2131	4
		3	255	781	2131	4
8mmHS+12mm AIR GAP+8mmTP THK. I.G.U.	28	4	10	723	2128	1
		5	2	636	2111	1
		6	2	648	2111	1
		7	2	740	2132	1
		8	2	841	2111	1
8mmHS+12mm AIR GAP+10mmTP THK. I.G.U	30	9	2	1102	2132	1
Not include FD			2736		47	

GLASS TAKEOFF Rec'd @ 28/5/24
via WHATSAPP

9. Approval of the Sub-Contractor's submission on samples, shop drawings and structural calculations by the Architect shall be made on the basis of checking the compliance of these submissions against the design intent. Such approval shall not relieve the Sub-Contractor of his design responsibility in any way including but not limited to choice of systems, correctness of dimensions, structural calculations, coordination and quality of the fabrication, assembly and installation processes and the compliance with all requirements stated in the Contract Documents.

1.7 GUARANTEE AND DEFECT LIABILITY PERIOD

1. The Sub-Contractor shall be required to submit the Certificate of Guarantee against faulty workmanship and material, loss of mechanical property, water leakage, structural failure, non-uniformity of surface, corrosion and distortion, discolor on anodized aluminium or other organic coating system.
2. Defect Liability Period shall be 39 months to salable residential unit and 15 months to non-salable areas as well as shopping mall, ground floor lobby & etc., both from date of issuance of Practical Completion Certificate.
3. Guarantee Period shall be 15 years after issuance of the Practical Completion Certificate for all of the following:-
 - i) Water leakage from External Facade System,
 - ii) Faulty workmanship,
 - iii) Faulty materials,
 - iv) Loss of mechanical properties,
 - v) Structural failure,
 - vi) Non-uniformity of surface,
 - vii) Corrosion and distortion, and
 - viii) Discolour on anodized aluminium and/or other organic coating system.
4. The guarantee from authorized sole agent for hardware, ironmongeries and automatic operators for doors (including sliding door, swing door and folding door) and for public area shall be 2 years.
5. A guarantee only from the Contractor, Direct Contractor or other contractor with product warranty of the manufacturer, supplier, specialist should be providing. For example: painting for Aluminium, glass, sealant...etc.

1.8 SPARE GLASS

1. When spare glass is specified by the Project Architect, the Sub-contractor shall allow spare glass to the Employer as a provisional lump sum to cover the following:
 - i) Typical vision panel: 1.5% of the total
 - ii) Typical openable sash: 1.5% of the total
2. The spare glass shall be of pre-cut and the sizes shall be selected by the Architect.

4:01

5G 72



J856天榮輕鐵站上蓋(公...
Andy Kwong · Midi - Alan 蔡凱倫...



上午 9:59

@Andy Kwong 上午 10:01

Midi - Garry Chan 大少

pdf T2 及 T3 玻璃總表.pdf
1 頁 · 283 KB · pdf

上午 11:42

Midi - Garry Chan 大少

T2 及 T3 玻璃總表.pdf · 1 頁



這是按合約 general specifications clause 1.8 要求，由 SHK 購料組確立的 spare glass BOM

下午 12:15 ✓✓

Midi - Garry Chan 大少

Ok

下午 12:15

這份表是購料組今天要求我們落 order

下午 12:17



天榮站趙門Spare玻璃(T2,T3)

項目	圖號	尺寸	數量(件)T2+T3	玻璃類型	備註
1	EGL-1A	738.5x2131mm	33	8mm THK. Clear HS Glass+12mm AIR GAP+8mm THK. Clear TP Glass	
2		696x2131mm	4		
3		781x2131mm	4		
4	EGL-1A	723x2128mm	1	8mmHS+12mm AIR GAP+8mmTP THK. I.G.U.	
5		636x2111mm	1		
6		648x2111mm	1		
7		740x2132mm	1		
8		841x2111mm	1		
9	EGL-1	1102x2132mm	1	8mmHS+12mm AIR GAP+10mmTP THK. I.G.U.	
		Total	47		

SD item 1-8

EG-DWG4

 美特铝质 有限公司 MIDI Aluminium Fabricator Ltd.				類別		物料號	
修改				制圖	黃瓊玉	2023.02.24	圖號 EGL-1A
日期				復核	謝永林	2023.02.25	數量 見BOM表
				批准			位置 見BOM表

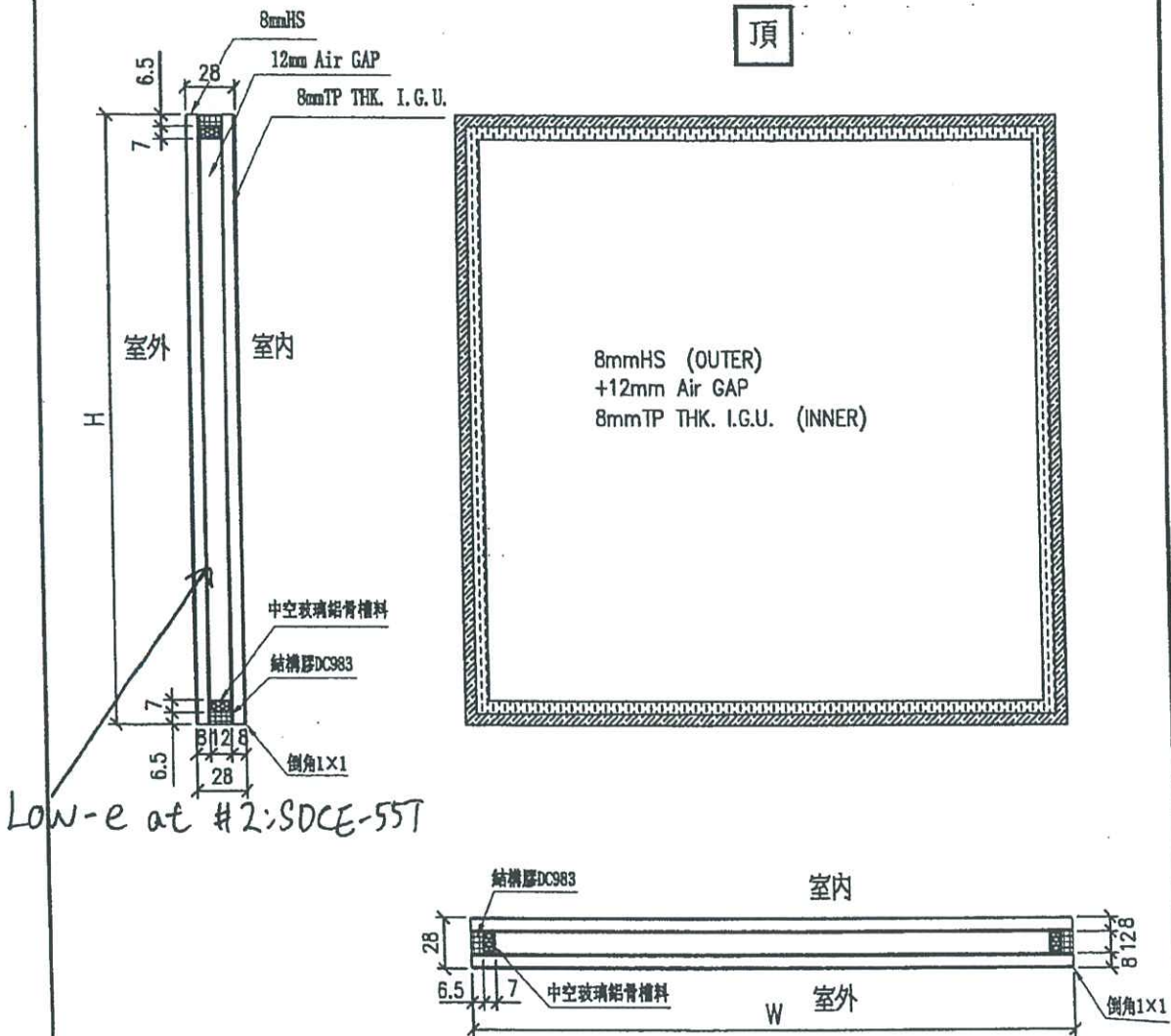

工程號	J-856	地盤	天水圍天樂站	附 件
名稱	玻璃加工	超明玻璃	採用	
材料			地盤 <input checked="" type="checkbox"/>	
顏色	8mmHS+12mm AIR GAP+8mmTP THK. I.G.U.	工廠		

 美特鋁質有限公司 MIDI Aluminium Fabricator Ltd.				類別	物料號		
				制圖	黃瓊玉	2023.02.24	圖號 EGL-1
修改				復核	謝永林	2023.02.25	數量 見BOM表
日期				批准			位置 見BOM表

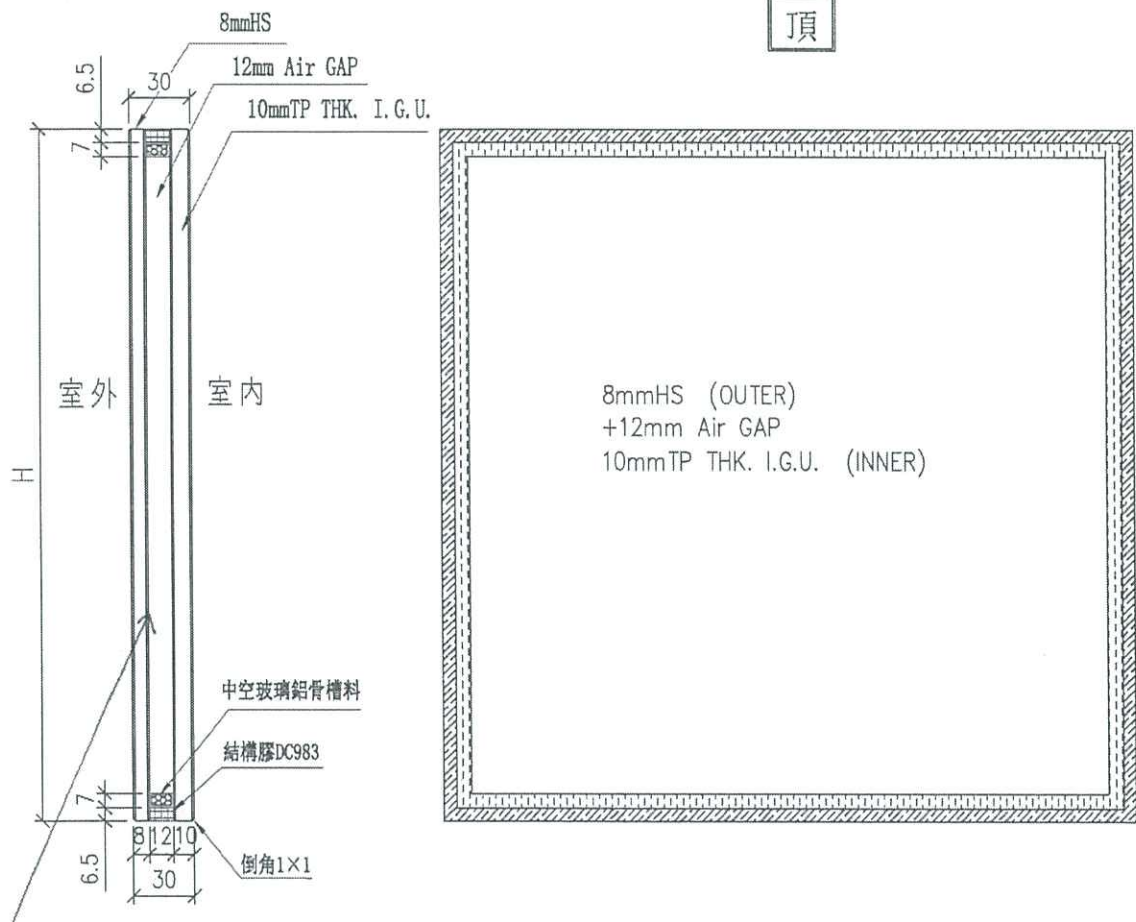

Low-e at #2:
SDCE-55T

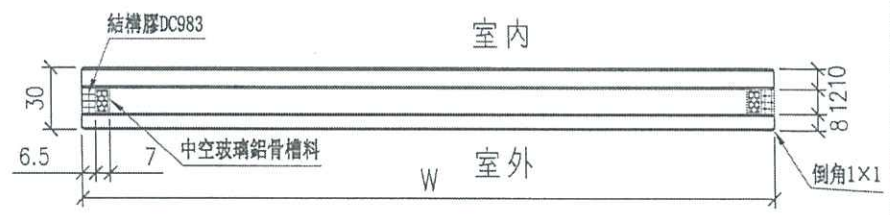

工程號	J-856	地盤	天水圍天榮站	附件
名稱	玻璃加工圖 (大梗窗玻璃+小梗窗玻璃)		採用	
材料			地盤 <input checked="" type="checkbox"/>	
顏色	8mmHS+12mm AIR GAP+10mmTP THK. I.G.U.		工廠 <input type="checkbox"/>	

天榮站幕牆Spare玻璃(T2,T3)

項目	圖號	尺寸	數量(件)T2+T3	玻璃類型	備註
1	GL-1	614x840mm	7	8mm Heat Strengthen + 12AIR+10mm Tempered Glass(Vision)	GL1-F01
2		1551.5x2005mm	1		
3		1321.5x2005mm	1		
4		614x1405mm	1		
5		1834x2005mm	1		
6		849x840mm	1		
7		1371.5x2005mm	1		
8		614x1105mm	7		
9		849x1105mm	1		
10		921.5x2005mm	2		
11		1569x2005mm	2		
12		729x2005mm	2		
13		884x840mm	1		
14		1284x2005mm	1		
15		814x840mm	1		
16		1171.5x2005mm	1		
17		884x1105mm	1		
18		814x1105mm	1		
19		661x1105mm	2		
20		661x840mm	2		
21		1686.5x2005mm	1		
22		661x1405mm	1		
23		1911x2005mm	2		
24		561x1105mm	2		
25		1678.5x2005mm	2		
26		561x840mm	2		
27		761x1105mm	2		
28		761x840mm	2		
29		1811x2005mm	2		
30	GL1a	1911x2305mm	1	8mm Heat Strengthen + 12AIR+12mm Tempered Glass(Vision)	GL1A-F02
31		2164x2005mm	1		
32		1811x2305mm	1		
33	GL5	570x122mm	7	12mm Tempered Glass(Protective Barrier)	GL5-F01
34		497x122mm	2		
35		805x122mm	1		
36		597x122mm	2		
37		397x122mm	2		
38		770x122mm	1		
39		840x122mm	1		
		Total	72		

 美特鋁質有限公司 MIDI Aluminium Fabricator Ltd.				工程號 J856	類別 制圖	物料號 -		
				地盘 天榮站	制圖 劉燦	2022-10-18	圖號 GL1-F01	
修改 -	-	-	採用工廠 ✓	地盘 玻璃加工图	復核 徐詳坤	2022-19-19	數量 -	
日期 -	-	-	材料顏色	材料 GLASS	批准 林仁安	2022-10-19	單件重量 -	(KG)

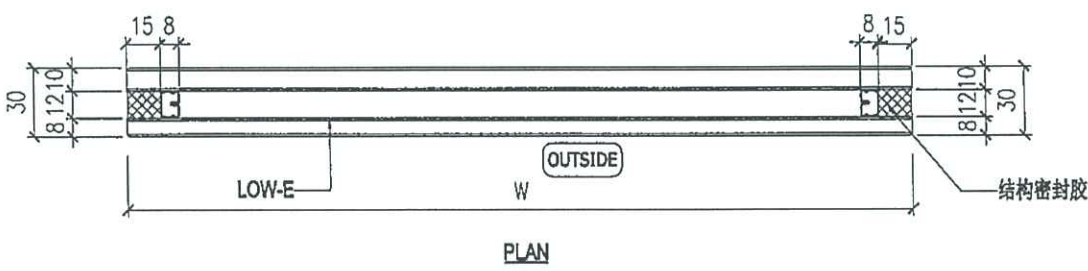
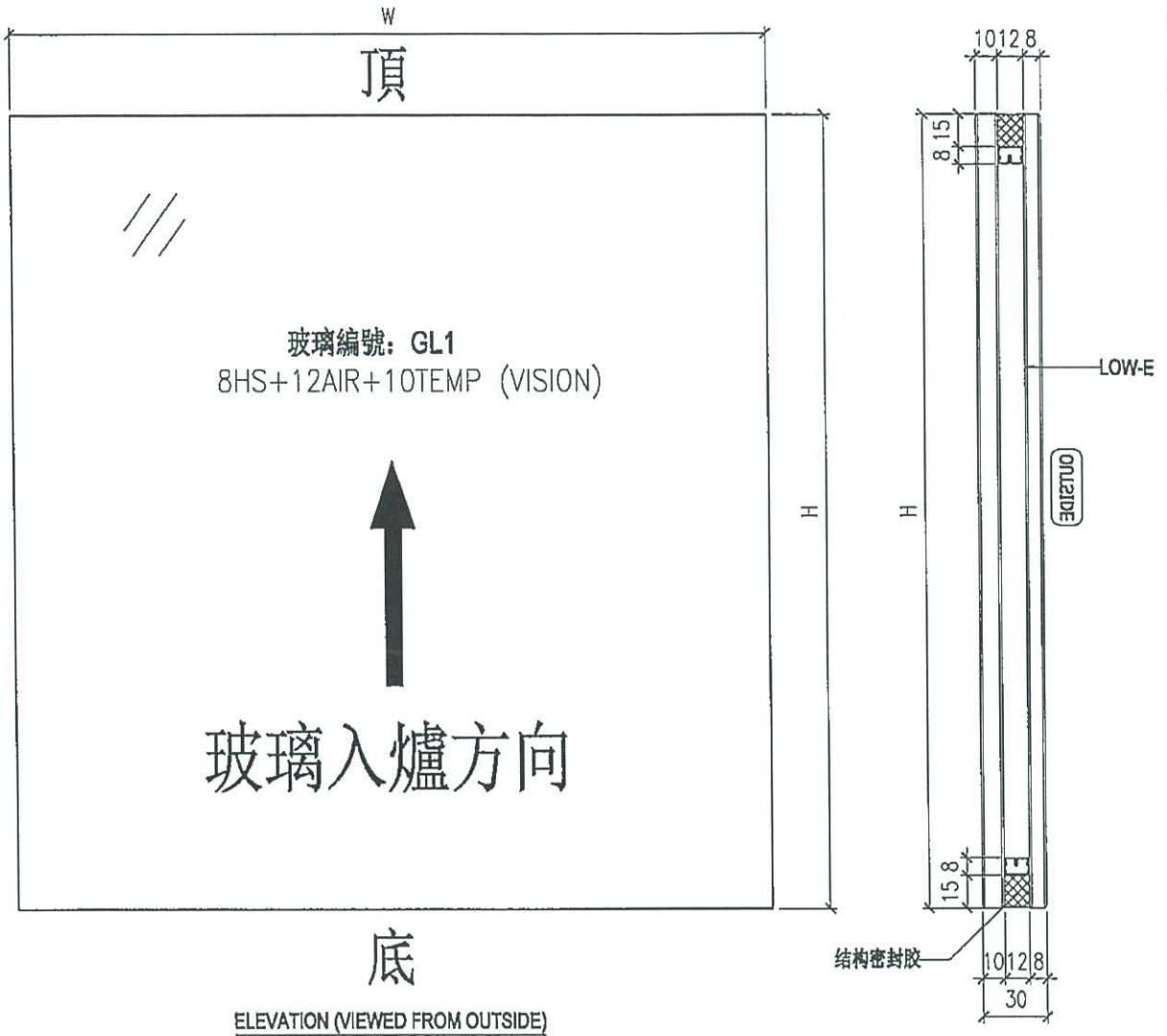

NOTES
 1. ALL DIMENSION IN mm
 2. ALL EDGE CHAMFER 1x1x45

CW item 19-26

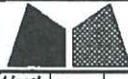
 美特鋁質有限公司 MIDI Aluminium Fabricator Ltd.			工程號 J856 地盘 天榮站	類別 制圖 劉燦	物料號 - 2022-10-18	圖號 GL1-F02
修改 - - - 日期 - - -	採用工廠 <input checked="" type="checkbox"/> 地盤 材料颜色	图纸名称 玻璃加工图 材料 GLASS	復核 徐詳坤 批准 林仁安	2022-19-19 2022-10-19	數量 - 單件重量 - (KG)	

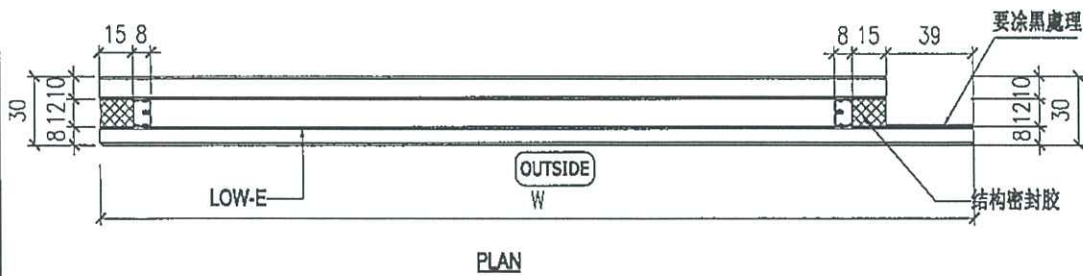
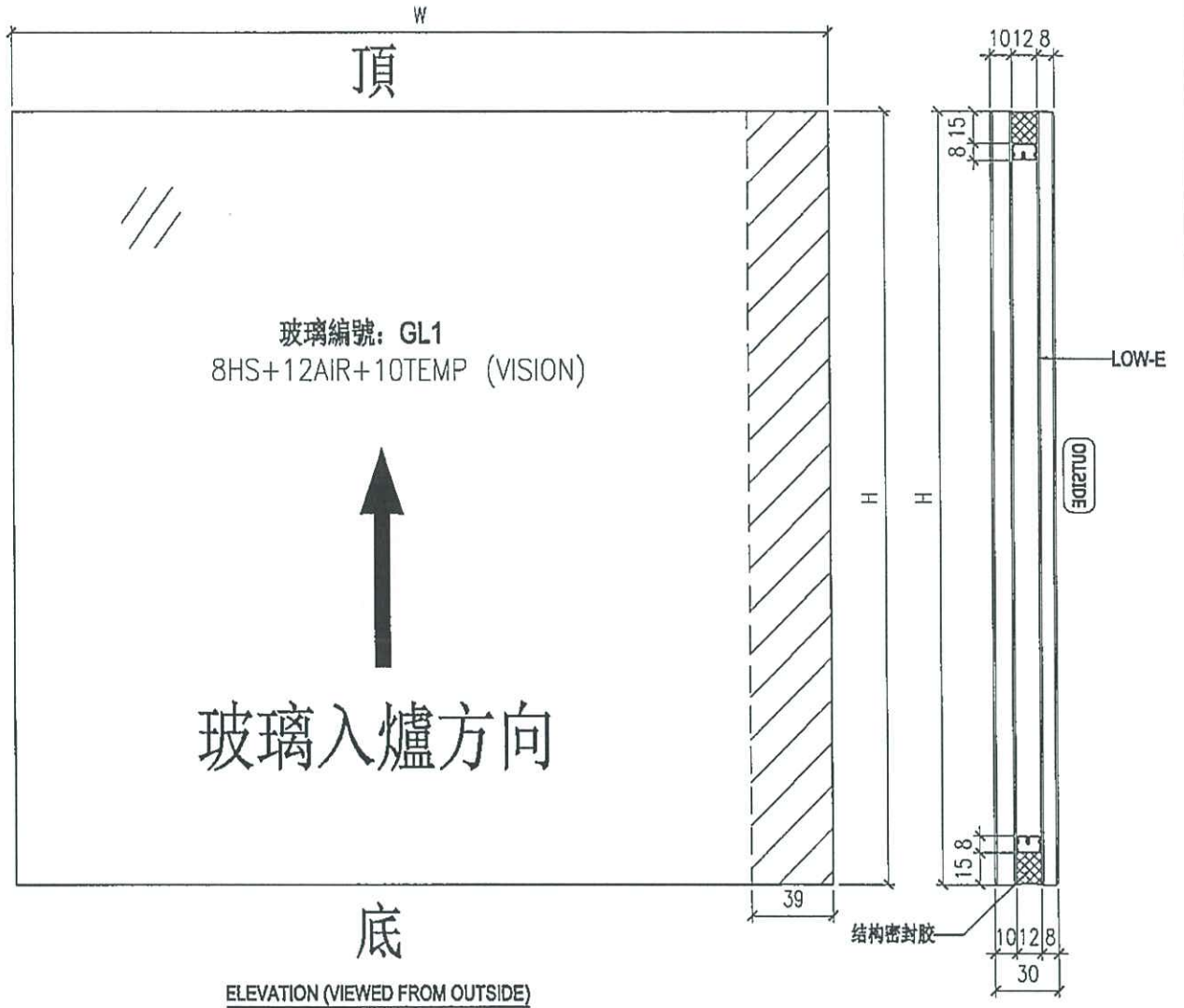

NOTES

1. ALL DIMENSION IN mm
2. ALL EDGE CHAMFER 1x1x45

CW item 27-29

 美特鋁質有限公司 MIDI Aluminium Fabricator Ltd.				工程號 J856 地盘 天榮站	類別 制圖 劉煥	物料號 - 2022-10-18	圖號 GL1-F03
修改 - 日期 -	採用工廠 ✓ 材料颜色	图纸名称 玻璃加工图 材料 GLASS	復核 徐詳坤 批准 林仁安	2022-19-19 2022-10-19	數量 - 單件重量 - (KG)		

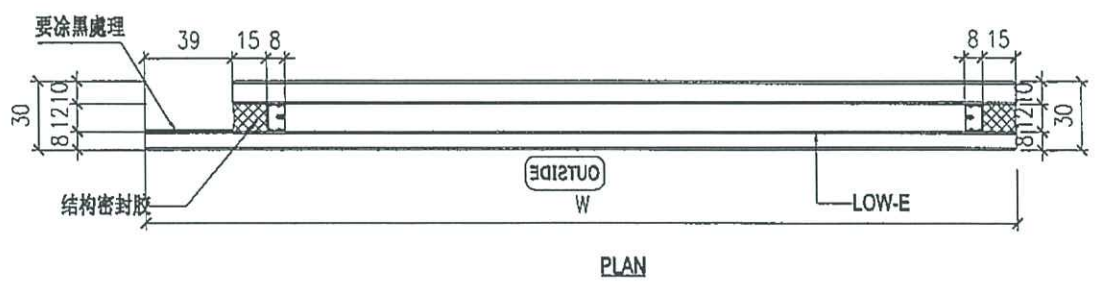
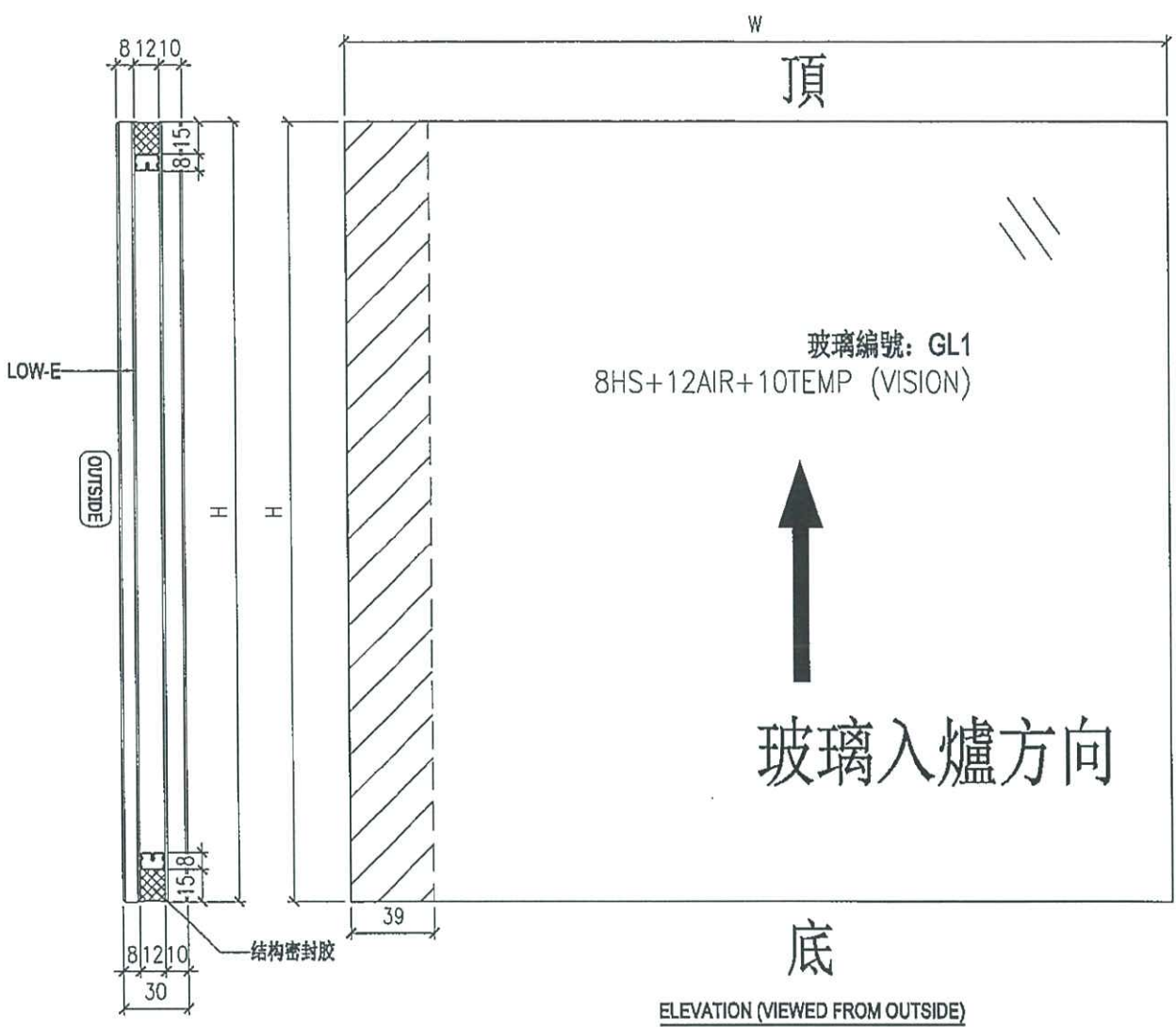

NOTES

- ALL DIMENSION IN mm
- ALL EDGE CHAMFER 1x1x45

CW item 30-32

 美特鋁質有限公司 MIDI Aluminium Fabricator Ltd.				工程號 J856 地盘 天榮站	類別 制圖 劉煥	物料號 - 圖號 GL1A-F02	
修改 - 日期 -	採用工廠 <input checked="" type="checkbox"/> 地盤 材料颜色	图纸名称 玻璃加工图 材料 GLASS	復核 徐詳坤 批准 林仁安	2022-10-18 2022-19-19 2022-10-19	數量 - 單件重量 -	(KG)	

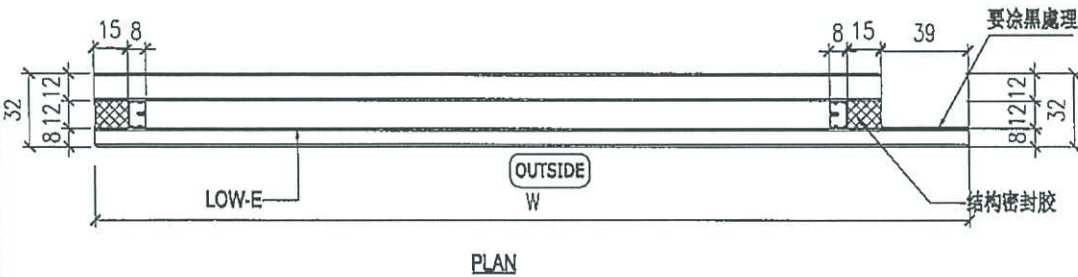
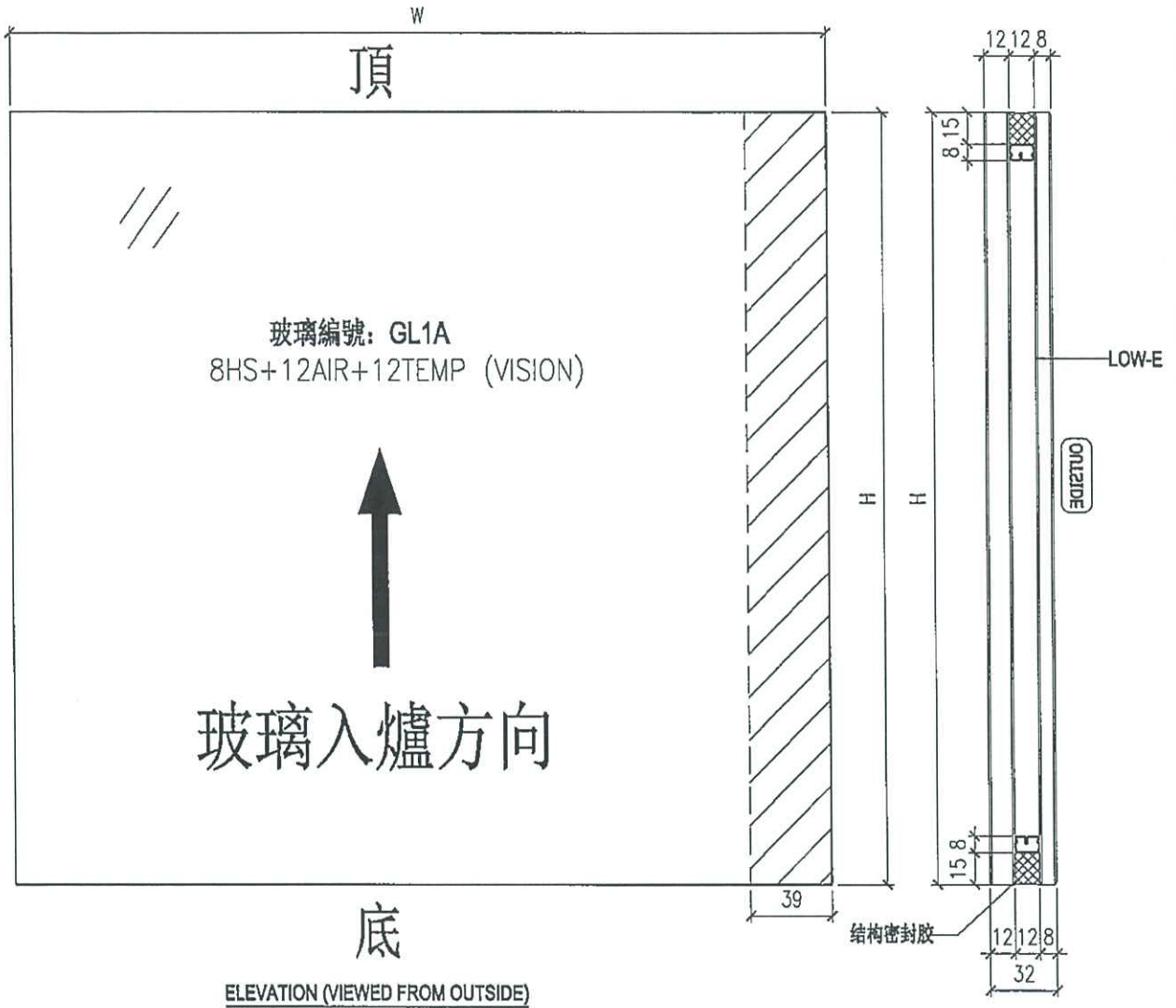

- NOTES
1. ALL DIMENSION IN mm
 2. ALL EDGE CHAMFER 1x1x45

CW item 33-39

 美特鋁質有限公司 MIDI Aluminium Fabricator Ltd.				工程號 J856 地盘 天榮站	類別 制圖 劉煥	物料號 - 圖號 GL5-F01	
修改 - - - 日期 - - -	採用工廠 <input checked="" type="checkbox"/> 地盤 材料颜色	图纸名称 玻璃加工图 材料 GLASS	復核 徐詳坤 批准 林仁安	2022-10-18 2022-10-19 2022-10-19	數量 - 單件重量 -	(KG)	

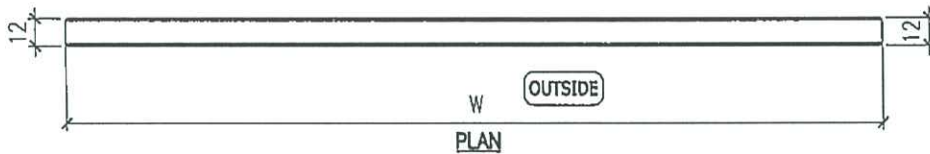
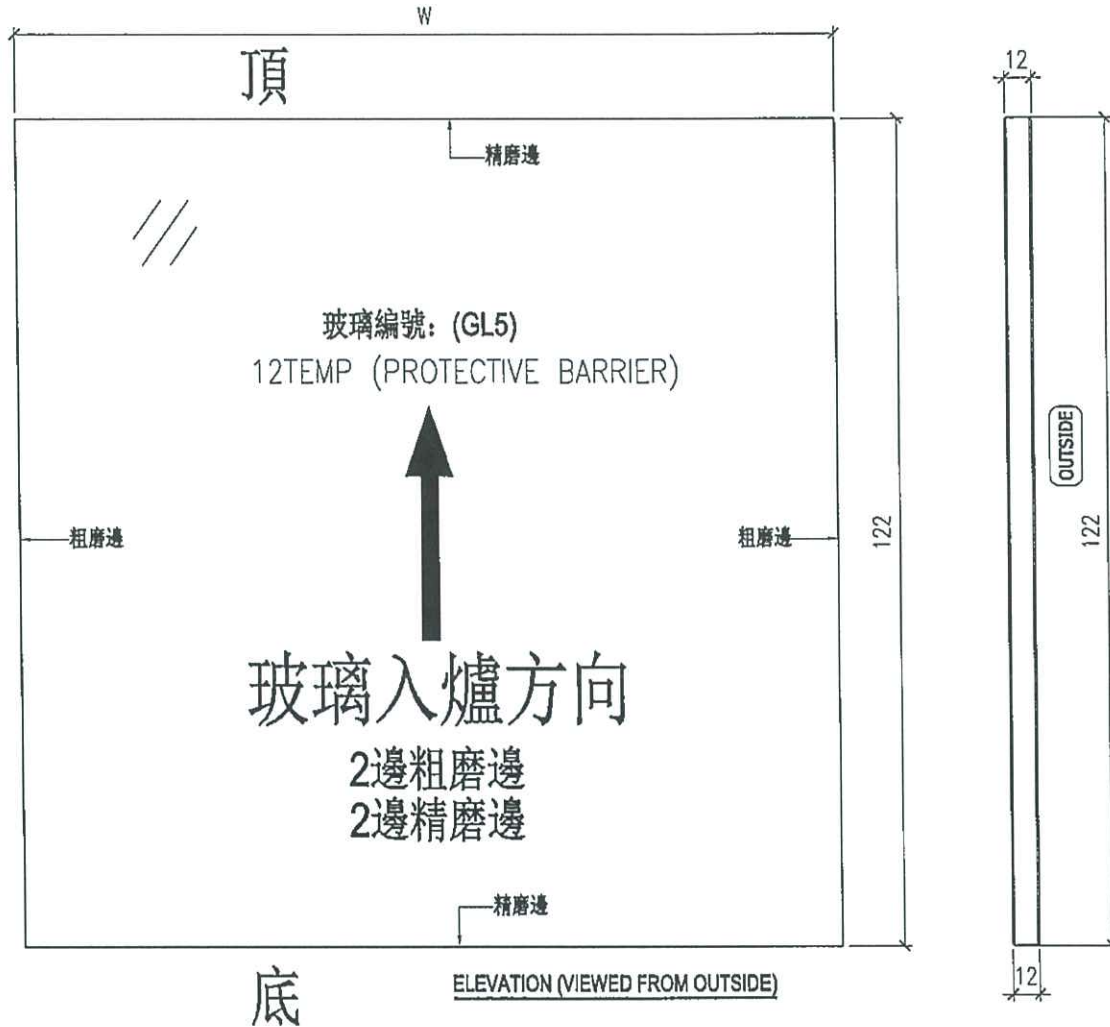

NOTES

1. ALL DIMENSION IN mm
2. ALL EDGE CHAMFER 1x1x45

天榮站鋁窗Spare玻璃(T2,T3)

項目	圖號	尺寸	數量(件)T2+T3	玻璃類型	備註		
1	EGL-1	452x544.5mm	18	8mmHS+12mm AIR GAP+10mmTP THK. I.G.U.			
2		452x774.5mm	15				
3		410x1720mm	18				
4		660x1720mm	2				
5		810mmx1950mm	7				
6		610x1950mm	7				
7		352x544.5mm	2				
8		462x544.5mm	2				
9		667x774.5mm	1				
10		982x774.5mm	1				
11		725x1950mm	2				
12		430x1950mm	2				
13		790x1910mm	2				
14		452x754.5mm	2				
15		590x1910mm	2				
16		437x759.5mm	2				
17		920x1930mm	1				
18		437x330mm	1				
19		945x1930mm	1				
20		1095x1930mm	1				
21		495x1930mm	1				
22		795x1930mm	1				
23		441x764mm	1				
27		979x1934mm	1				
28		1129x1934mm	1				
29		829x1934mm	1				
30		EGL-1B	452x544.5mm		1	8mmHS+12mm AIR GAP+10mm Clear Tempered Acid Etched THK. (Frosted on #3) I.G.U.	
31			452x774.5mm		1		
32		EGL-1A	450x1064.5mm		35	8mmHS+12mm AIR GAP+8mmTP THK. I.G.U.	
33	350x1064.5mm		2				
34	460x1064.5mm		2				
35	665x1064.5mm		1				
36	980x1064.5mm		1				
37	435x1059.5mm		2				
38	439x1063.5mm		1				
39	648.2x2262.2mm		1				
40	661.2x2262.2mm		1				
41	855x2262mm		1				

42	EGL-2	450x1080mm	2	10mm Crystal Gray Tempered Glass (For Kit & ST)	
43		430x1040mm	2		
44		320x1040mm	2		
45		450x1040mm	2		
46		420x1040mm	1		
47		500x1040mm	1		
48	EGL-4	420x1040mm	2	10mm Crystal Gray Tempered Acid Etched (For Bath)	
49		320x1040mm	2		
50		570x1040mm	1		
51	EGL-1	462x544.5mm	1	8mmHS+12mm AIR GAP+10mm Clear Tempered Acid Etched THK. I.G.U.	
52		452x754.5mm	1		
		Total	161		

 美特鋁質有限公司 MIDI Aluminium Fabricator Ltd.				類別	物料號		
修改				制圖 黃瓊玉	2023.02.24	圖號 EGL-1	
日期				復核 謝永林	2023.02.25	數量 見BOM表	
				批准		位置 見BOM表	

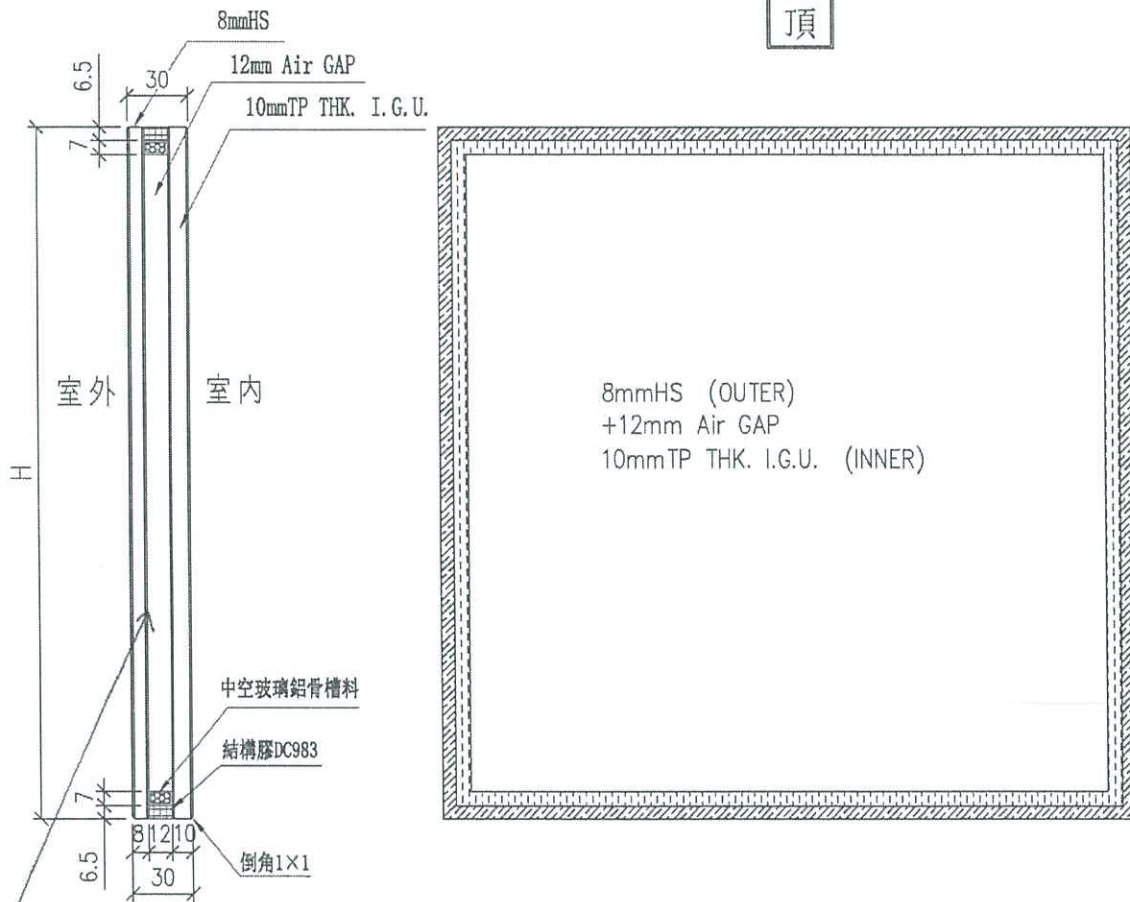

Low-e at #2:
SDCE-55T

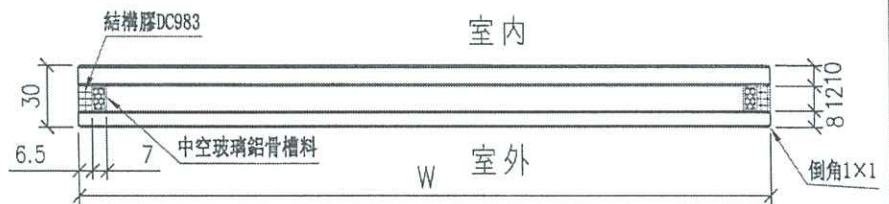

工程號	J-856	地盤	天水圍天榮站	附 件
名稱	玻璃加工圖 (大梗窗玻璃+小梗窗玻璃)		採用	
材料			地盤 <input checked="" type="checkbox"/>	
顏色	8mmHS+12mm AIR GAP+10mmTP THK. I.G.U.		工廠 <input type="checkbox"/>	

 美特鋁質有限公司 MIDI Aluminium Fabricator Ltd.				類別	物料號			
				制圖	黃瓊玉	2023.06.29	圖號	EGL-1B
修改				復核	謝永林	2023.06.29	數量	見BOM表
日期				批准			位置	見BOM表

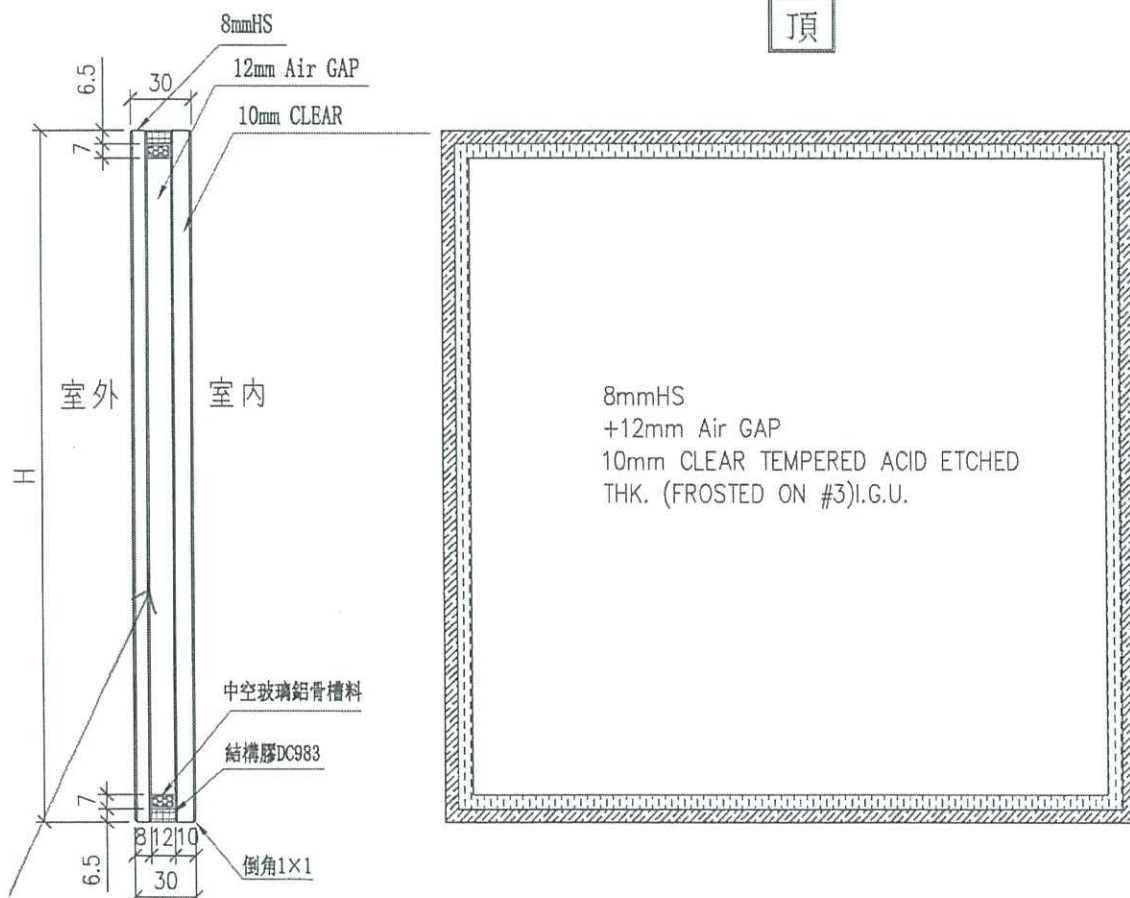

Low-e at #2:
SPCE-55T.

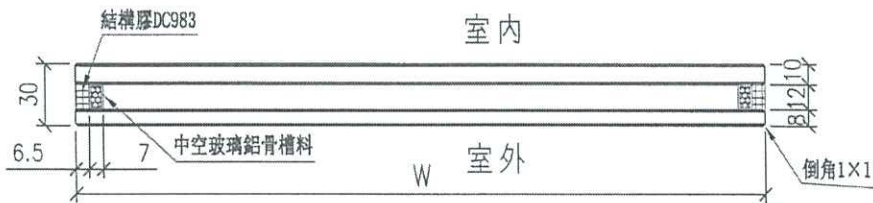

工程號	J-856	地盤	天水圍天榮站	附 件	
名稱	玻璃加工圖(小梗窗玻璃)		採用		
材料			地盤		√
顏色	8mmHS+12mm AIR GAP+10mmCLEAR		工廠		

 美特鋁質有限公司 MIDI Aluminium Fabricator Ltd.				類別	物料號		
修改				制圖 黃瓊玉	2023.02.24	圖號 EGL-1A	
日期				復核 謝永林	2023.02.25	數量 見BOM表	
				批准		位置 見BOM表	

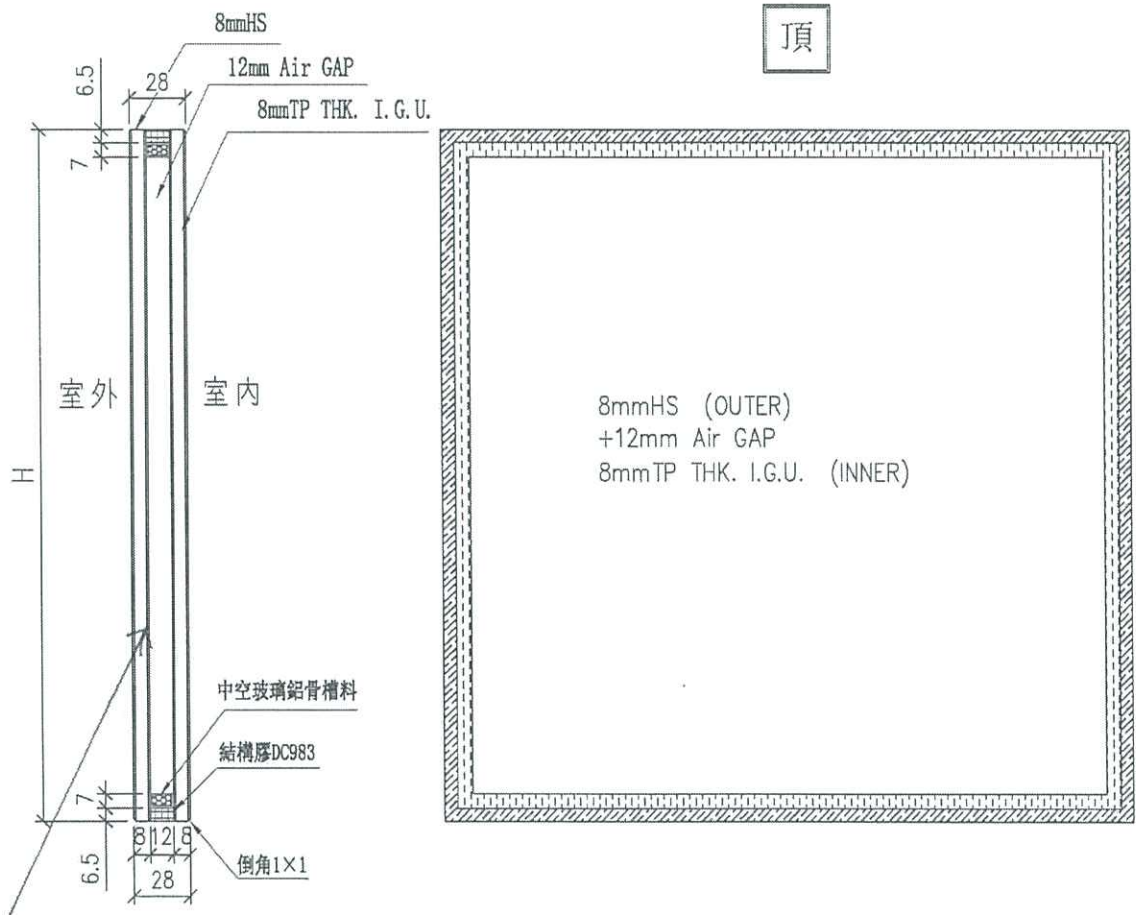

Low-e at #2:
SDCE-55T.

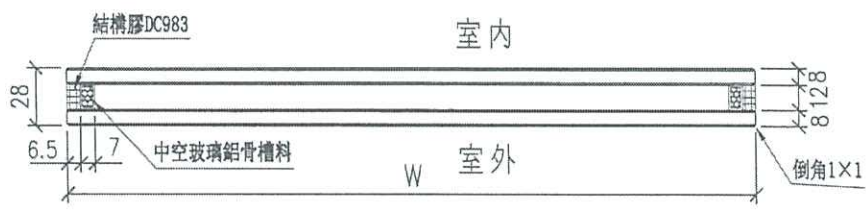

工程號	J-856	地盤	天水圍天榮站	附件
名稱	玻璃加工圖 (70生窗玻璃)		採用	
材料			地盤 <input checked="" type="checkbox"/>	
顏色	8mmHS+12mm AIR GAP+8mmTP THK. I.G.U.		工廠 <input type="checkbox"/>	

 美特鋁質有限公司 MIDI Aluminium Fabricator Ltd.				類別		物料號		
修改				制圖	黃瓊玉	2023.02.24	圖號	EGL-2
日期				復核	謝永林	2023.02.25	數量	見BOM表
				批准			位置	見BOM表

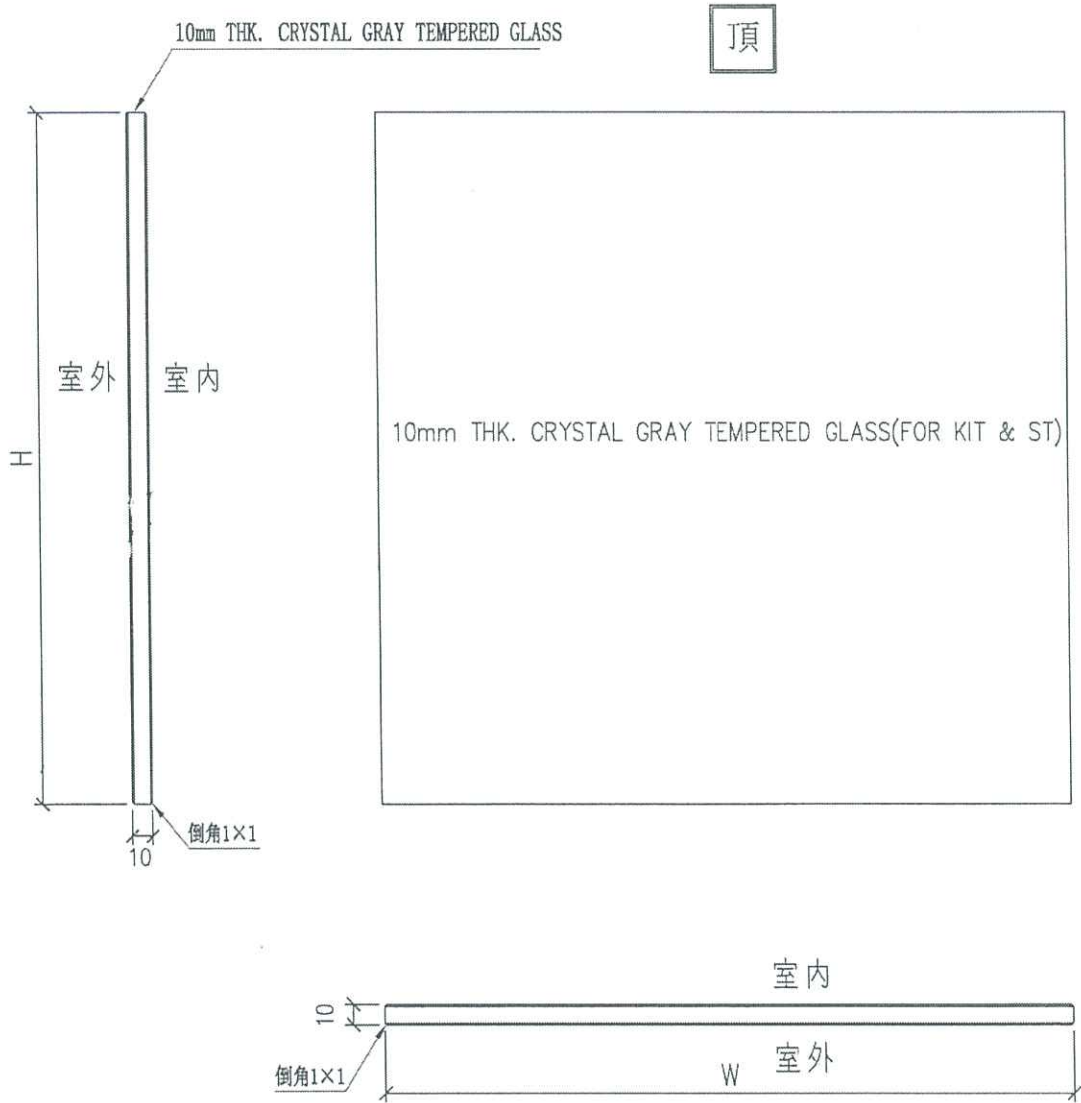

工程號	J-856	地盤	天水圍天榮站	附 件
名稱	玻璃加工圖 (50生窗玻璃)		採用	
材料		地盤	√	
顏色	10mm THK. CRYSTAL GRAY TEMPERED GLASS		工廠	

 美特鋁質有限公司 MIDI Aluminium Fabricator Ltd.				類別		物料號		
修改				制圖	黃瓊玉	2023.02.24	圖號	EGL-4
日期				復核	謝永林	2023.02.25	數量	見BOM表
				批准			位置	見BOM表

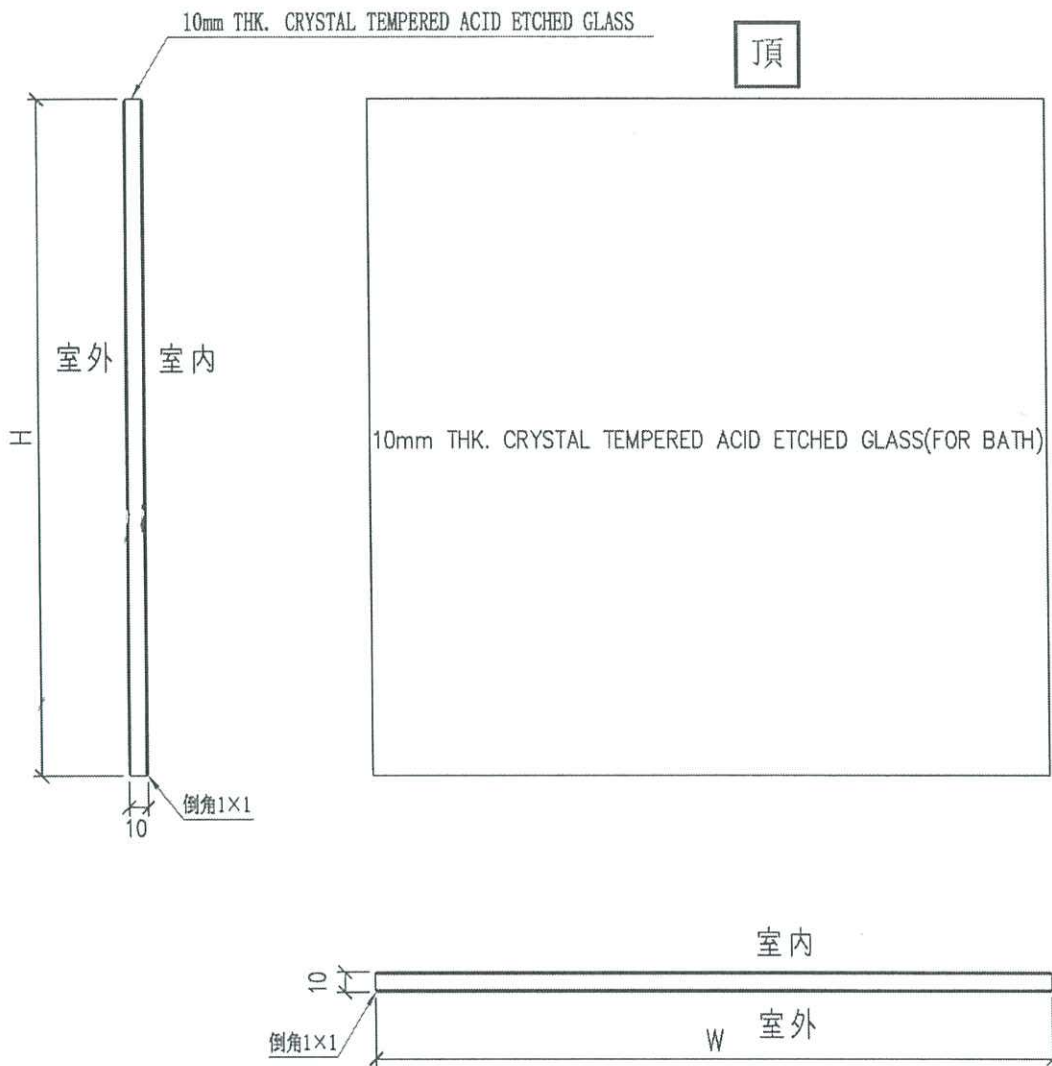

工程號	J-856	地盤	天水圍天榮站	附件	
名稱	玻璃加工圖 (50窗玻璃)		採用		
材料			地盤		√
顏色	10mm THK. CRYSTAL TEMPERED ACID ETCHED GLASS		工廠		