



工程指示 / 要求簡箋 ENGINEER INSTRUCTIONS(E.I.)

工程指示編號:	EI- 6732	修改版本:	-
	HK- 2135		
工程編號:	J 856	工程名稱:	TSWTL23 天榮
收件人:	生統/謝永林	發件人:	Thomas Wong
工程項目:	Insitu louver 5th Shop Drawing 拆圖用	日期:	14/09/2023

<input checked="" type="checkbox"/> 原合約工程包	<input type="checkbox"/> 原合約工程加 / 減賬 QT-	<input type="checkbox"/> 新工程報價 QT-
--	--	------------------------------------

信件批核號碼/圖紙參考編號:	批核模具圖紙編號:
客戶指示附件:	管理內部批簽署:

<input type="checkbox"/> 初步鋁料 B.M.	<input type="checkbox"/> 加工拆圖, 然後生產	<input type="checkbox"/> 尺寸表
<input type="checkbox"/> 正式鋁料 B.M.	<input type="checkbox"/> 技術上資料/指示	<input type="checkbox"/> 報價
<input type="checkbox"/> 配件 B.M.	<input type="checkbox"/> 樣辦或貨品說明書	<input type="checkbox"/> 分判合約
<input type="checkbox"/> 其他:		

內容: Insitu louver 5th Shop Drawing 請按附件的Shop Drawing拆圖(存伺服器)
完成上列要求日期: 20/09/2023

國內

<input type="checkbox"/> 生產技術總監	<input type="checkbox"/> 連附件	<input checked="" type="checkbox"/> 技術部	<input checked="" type="checkbox"/> 連附件	<input type="checkbox"/> 生產部	<input type="checkbox"/> 連附件
<input type="checkbox"/> 採購部	<input type="checkbox"/> 連附件	<input checked="" type="checkbox"/> 生產統籌部	<input checked="" type="checkbox"/> 連附件	<input type="checkbox"/> 報關組	<input type="checkbox"/> 連附件
<input type="checkbox"/> 質檢部	<input type="checkbox"/> 連附件	<input type="checkbox"/> 會計部	<input type="checkbox"/> 連附件	<input type="checkbox"/> 機械設計部	<input type="checkbox"/> 連附件
<input type="checkbox"/> 香港辦	<input type="checkbox"/> 連附件	<input checked="" type="checkbox"/> 其他: 謝永林			

香港

<input type="checkbox"/> 行政部	<input type="checkbox"/> 連附件	<input type="checkbox"/> 會計部	<input type="checkbox"/> 連附件	<input type="checkbox"/> 統籌部	<input type="checkbox"/> 連附件	<input type="checkbox"/> 工程部	<input type="checkbox"/> 連附件
<input type="checkbox"/> 採購部	<input type="checkbox"/> 連附件	<input type="checkbox"/> QS部	<input type="checkbox"/> 連附件	<input type="checkbox"/> 地盤管理	<input type="checkbox"/> 連附件	<input type="checkbox"/> 維修部	<input type="checkbox"/> 連附件

*發件人簽署: 瑋	*組別成員批核簽署: J -
傳遞編號:	項目經理簽署:

PROJECT :

PROPOSED DEVELOPMENT ABOVE
LIGHT RAIL TIN WING STOP, TSWTL
NO.23, AREA 33, TIN SHUI WAI, N.T.

5

SHOP DRAWING FOR IN-SITU LOUVER OF TOWER

DATE: 11-Sep-23



DRAWING SUBMISSION REGISTER

PROJECT: PROPOSED DEVELOPMENT ABOVE LIGHT RAIL TIN WING STOP, TSWTL NO.23, AREA 33, TIN SHUI WAI, N.T. TITLE: IN-SITU LOUVER OF TOWER SHOPDRAWING SUBMISSION	DATE OF ISSUE										SUBMISSION STATE (FOR B.D / A.S.D)			SUBMISSION STATE (FOR CLIENT / CONSULTANT)			SUBMISSION STATE (FOR ARCHITECT)			FABRICATION / CONSTRUCTION STATE						
	ISSUE	1	2	3	4	5						AP - APPROVED			AP - APPROVED			AP - APPROVED			ISSUE TO CHINA OFFICE		ISSUE TO SITE		ISSUE TO SUB-CONTRACTOR	
	DAY	25	13	19	10	11						AC - APPROVED SUB. TO CONDITION			AC - APPROVED SUB. TO CONDITION			AC - APPROVED SUB. TO CONDITION								
	MONTH	8	6	7	8	9						NA - NOT APPROVED			NA - NOT APPROVED			NA - NOT APPROVED								
	YEAR	21	23	23	23	23																				
DRAWING TITLE	DWG. NO.	REVISIONS										COMMENT DATE	REV.	STATE	COMMENT DATE	REV.	STATE	COMMENT DATE	REV.	STATE	REV.	DATE	REV.	DATE	REV.	DATE
COVER PAGE	J856-SD-LV-0000	-	A	B	C	D																				
DRAWING REGISTER	J856-SD-LV-0001	-	A	B	C	D																				
GENERAL NOTES FOR IN-SITU LOUVER OF TOWER	J856-SD-LV-0101			-	-	A																				
DIE LIST FOR IN-SITU LOUVER	J856-SD-LV-1001			-	-	A																				
PLAN FOR IN-SITU LOUVER AT TOWER 1 R/F	J856-SD-LV-3107	-	A	A	A	A																				
PLAN FOR IN-SITU LOUVER AT TOWER 1 UR/F	J856-SD-LV-3108	-	A	A	A	A																				
PLAN FOR IN-SITU LOUVER AT TOWER 2 R/F	J856-SD-LV-3207	-	A	A	A	A																				
PLAN FOR IN-SITU LOUVER AT TOWER 2 UR/F	J856-SD-LV-3208	-	A	A	A	B																				
PLAN FOR IN-SITU LOUVER AT TOWER 3 R/F	J856-SD-LV-3307	-	A	A	B	C																				
PLAN FOR IN-SITU LOUVER AT TOWER 3 UR/F	J856-SD-LV-3308		A	A	A	A																				
WINDOW SCHEDULE FOR TOWER IN-SITU LOUVER	J856-SD-LV-5001	-	A	A	B	B																				
WINDOW SCHEDULE FOR TOWER IN-SITU LOUVER	J856-SD-LV-5002	-	A	A	B	C																				
WINDOW SCHEDULE FOR TOWER IN-SITU LOUVER	J856-SD-LV-5003	-	-	-	A	A																				
TYPICAL DETAILS FOR IN-SITU LOUVER	J856-SD-LV-6011	-	-	A	B	B																				
TYPICAL DETAILS FOR IN-SITU LOUVER	J856-SD-LV-7008A	-	-	A	B	B																				
TYPICAL DETAILS FOR IN-SITU LOUVER	J856-SD-LV-7008B				-	-																				
G.M.S. FIXING LUG TYPICAL DETAIL FOR IN-SITU LOUVER	J856-SD-LV-7009			-	A	A																				

IN-HOUSE DESIGN CHECKER



美特鋁質有限公司
MIDI ALUMINIUM FABRICATOR LTD.
 Units 6-8, Sunray Industrial Centre, 1/F
 610 Cha Kwo Ling Road, Kowloon
 Tel: 23489211-4 Fax: (852) 27727666

DWG NO. : J852-SD-LV-0001 REV. : D

GENERAL NOTES FOR IN-SITU LOUVER OF TOWER

CODES AND STANDARDS

1. CODE OF PRACTICE ON WIND EFFECTS IN HONG KONG 2004.
2. CODE OF PRACTICE FOR DEAD AND IMPOSED LOADS 2011.
3. CODE OF PRACTICE FOR STRUCTURAL USE OF CONCRETE 2013.
4. CODE OF PRACTICE FOR THE STRUCTURAL USE OF STEEL 2011.
5. STRUCTURAL USE OF ALUMINIUM, BS 8118-1:1991. (WIND LOAD FACTOR OF 1.4 FOR ALUMINIUM DESIGN TO PNAP APP53)
6. BUILDING (CONSTRUCTION) REGULATIONS CAP 123.

DESIGN WIND LOAD

CODE OF PRACTICE ON WIND EFFECTS IN HONG KONG 2004.

	VERTICAL SURFACE
HEIGHT ABOVE GROUND LEVEL	<148.3m
BASIC WIND PRESSURE	3.044kPa
TOPOGRAPHY FACTOR (S _z)	1.00
PRESSURE COEFFICIENT (C _p)	+1.0/-1.4
DESIGN WIND PRESSURE	(+2.0) -4.261kPa

STEEL

ALL STRUCTURAL STEEL SECTIONS SHALL BE GRADE S275 JO CLASS 1 WELDABLE STRUCTURAL STEEL AND COMPLYING WITH BS EN 10210 2006 FOR HOLLOW SECTION AND BS EN 10025 FOR OTHER SECTIONS.

ALL STRUCTURAL STEEL SHALL BE HOT-DIP GALVANIZED AND COMPLY WITH BS EN ISO 1461 WITH MIN 85 µm COATING THICKNESS.

ALL CUT/WELDED AREAS IN GALVANIZED STEEL SHALL BE MADE GOOD BY AT LEAST TWO COATS OF ZINC RICH PRIMER TO BS 4652.

DENSITY	77kN/m ³
YOUNG'S MODULUS	205,000MPa
YIELD STRENGTH	275MPa
MINIMUM TENSILE STRENGTH	430MPa
DESIGN STRENGTH (t≤16mm)	275MPa
DESIGN STRENGTH (t≤40mm)	265MPa

ALUMINIUM EXTRUSION

UNLESS OTHERWISE STATED, ALL ALUMINIUM EXTRUSIONS SHALL BE GRADE 6063-T6 AND COMPLY WITH BS EN 755-2 AND BS EN 573-3.

DENSITY	27.2kN/m ³
YOUNG'S MODULUS	70,000MPa
	6063-T6
0.2% PROOF STRESS	160MPa
MINIMUM TENSILE STRENGTH	215MPa
LIMITING BENDING STRENGTH	160MPa
LIMITING TENSILE STRENGTH	175MPa
LIMITING SHEAR STRENGTH	95MPa

ALUMINIUM PANEL

ALL ALUMINIUM PANEL TO BE GRADE 3004-H14 TO BS EN 485-2 : 2008 AND BS EN 573-3:2009

DENSITY	27.2kN/m ³
YOUNG'S MODULUS	70,000 N/mm ²
0.2% PROOF STRESS	125 N/mm ²
MINIMUM TENSILE STRENGTH	145 N/mm ²
LIMITING BENDING STRENGTH	125 N/mm ²
LIMITING TENSILE STRENGTH	135 N/mm ²
LIMITING SHEAR STRENGTH	75 N/mm ²

FASTENERS/SCREWS

ALL STAINLESS STEEL SCREW AND BOLT SHALL BE GRADE 316 AND COMPLY WITH BS EN ISO 3506.

0.2% PROOF STRESS	450MPa
MINIMUM TENSILE STRENGTH	700MPa
DESIGN TENSILE STRENGTH	450MPa
DESIGN SHEAR STRENGTH	311MPa
DESIGN BEARING STRENGTH	828MPa

PROTECTION OF BI-METALLIC CORROSION (BITAMEN PAINT ECT.)

ALL EXPOSED SURFACE OF ALUM. EXTRUSION SHALL BE FINISHED WITH PVF2 COATING ≥ 40 MICRONS

ALL SCREWS SHALL BE M5 S.S SCREW SPACING @300c/c MAX. UNLESS OTHERWISE STATED.

CONCRETE

ALL CONCRETE STRUCTURES SHOWN IN THIS SUBMISSION ARE FOR INFORMATION ONLY.

CONCRETE STRENGTH SHALL BE 45MPa. (MIN.)

B.D. REF.	TYPE	MINIMUM CONCRETE THICKNESS (mm)	EFFECTIVE ANCHORAGE DEPTH (mm)	MINIMUM EDGE DISTANCE (mm)	MINIMUM SPACING (mm)	RECOMMENDED TENSILE FORCE (KN)	RECOMMENDED SHEAR FORCE (KN)	PULL-OUT TEST LOAD (KN)	CONCRETE FACTOR (KN)
BD-AF 149 (FOR CRACKED CONCRETE)	"HILTI" HST3-R M12 SAFETY ANCHOR BOLTS	120	70	60	50	6.7	12.2	1.50 x 6.7 = 10.05	1.342 x 10.05 = 13.487

FIXING LUG

THE SIZE OF STAINLESS STEEL (GRADE 304) FIXING LUG TO BE 1.5mm THK. AND SPACING @300mm C/C MAX. UNLESS OTHERS STATED.

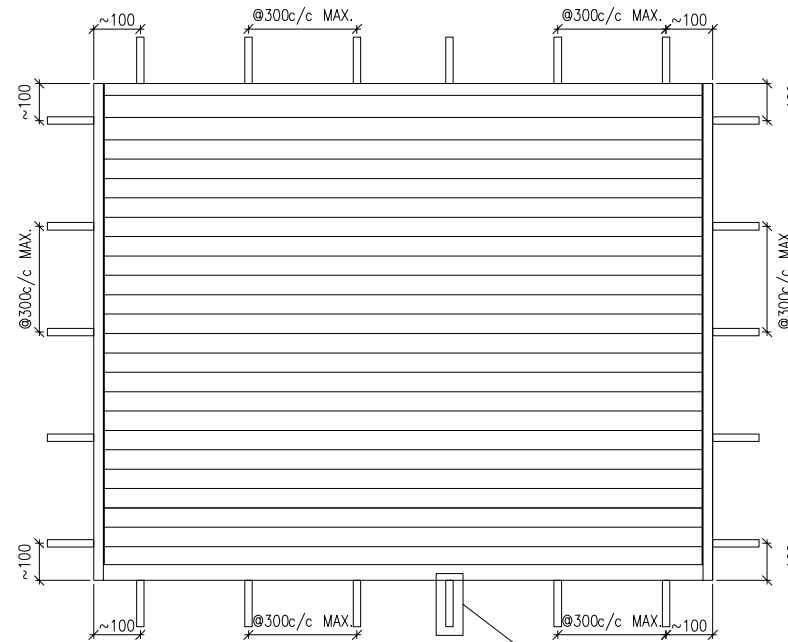

TYP. DETAIL FOR FIXING LUG

REFER TO DWG.
J856-SD-LV-7009

DRIVE PIN

DRIVE PIN TO BE "HILTI" X-P 27 P8. DESIGN & INSTALLATION SHOULD BE COMPLIED WITH MANUFACTURER'S RECOMMENDATION RECOMMEND TENSILE OR SHEAR LOAD=1.6KN MIN. EMBED DEPTH=25mm FACTOR OF SAFETY=4.0

WATERPROOFING COATING

ALL WATERPROOFING COATING SHALL BE (MASTERSEAL 540 , 2 COATS), AROUND LOUVER FRAME FOR 150mm MIN.

B.D. REF :

CLIENT :

SUN HUNG KAI
REAL ESTATE AGENCY LTD.
42/F SUN HUNG KAI CENTRE, WANCHAI, HONGKONG

ARCHITECT :

lwk&partners
architects

MAIN CONTRACTOR :

Yee Fai Building Contractors Ltd.

STRUCTURAL ENGINEER :

ARUP

FACADE CONSULTANT:

ALPHA CONSULTING LIMITED
Steel Structure & Facade Specialist

NOTE :

1. ALL DIMENSIONS ARE IN mm.
2. ALL ELEVATIONS ARE VIEWED FROM OUTSIDE.
3. ALL DIMENSIONS TO BE VERIFIED ON SITE BEFORE FABRICATION.

LEGEND :

NO.	DATE	REVISION	BY
A	11/09/2023	REVISION SUBJECT TO ALPHA COMMENT	IC

JOB NO. : J-856

PROJECT :
PROPOSED DEVELOPMENT ABOVE
LIGHT RAIL TIN WING STOP, TSWTL
NO.23, AREA 33, TIN SHUI WAI, N.T.

TITLE :
GENERAL NOTES FOR
IN-SITU LOUVER
OF TOWER

DATE : 12-Sep-22 SCALE : 1:3

DRAWN BY : Ivan CHECKED BY :

美特鋁質有限公司
MIDI ALUMINIUM FABRICATOR LTD.
Units 6-8, Sunray Industrial Centre, 1/F
610 Cha Kwo Ling Road, Kowloon
Tel: 23489211-4 Fax: (852) 27727666

DWG NO. : J856-SD-LV-0101 REV. : A

PROPERTIES

MEMBER : IW-01
GRADE : 6063-T6
FINISH : PVF2 3-COATING

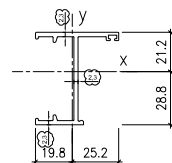

REGIONS	
MISS PROPERTIES (UNIT)	VALUES
Area (mm ²) :	346.43
Perimeter (mm) :	260.77
Bounding Box - X (mm) :	-19.80 to 25.20
Bounding Box - Y (mm) :	-28.79 to 21.21
Centroid - X (mm) :	0.00
Centroid - Y (mm) :	0.00
Moments of inertia - X (mm ⁴) :	133489.55
Moments of inertia - Y (mm ⁴) :	31190.83
Product of inertia - XY (mm ⁴) :	-20565.89
Radius of gyration - X (mm) :	19.63
Radius of gyration - Y (mm) :	9.49
Principal moments along X-Y (mm ⁴) :	132279.20 along (0.98 -0.19)
Principal moments along Y-X (mm ⁴) :	27401.18 along (0.19 0.98)
Elastic Modulus - E _x (mm ²) :	1 / y-max= 463634
Elastic Modulus - E _y (mm ²) :	1 / x-max= 123736

PROPERTIES

MEMBER : IW-03
GRADE : 6063-T6
FINISH : PVF2 3-COATING

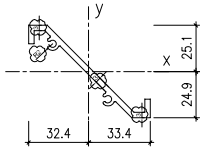

REGIONS	
MISS PROPERTIES (UNIT)	VALUES
Area (mm ²) :	330.84
Perimeter (mm) :	236.46
Bounding Box - X (mm) :	-32.39 to 33.36
Bounding Box - Y (mm) :	-24.93 to 25.07
Centroid - X (mm) :	0.00
Centroid - Y (mm) :	0.00
Moments of inertia - X (mm ⁴) :	90239.64
Moments of inertia - Y (mm ⁴) :	131492.97
Product of inertia - XY (mm ⁴) :	105223.93
Radius of gyration - X (mm) :	16.52
Radius of gyration - Y (mm) :	19.94
Principal moments along X-Y (mm ⁴) :	3145.12 along (0.77 -0.64)
Principal moments along Y-X (mm ⁴) :	218587.49 along (0.64 0.77)
Elastic Modulus - E _x (mm ²) :	1 / y-max= 3598.91
Elastic Modulus - E _y (mm ²) :	1 / x-max= 3841.11

PROPERTIES

MEMBER : IW-06
GRADE : 6063-T6
FINISH : PVF2 3-COATING

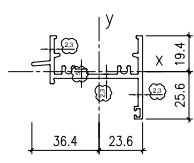

REGIONS	
MISS PROPERTIES (UNIT)	VALUES
Area (mm ²) :	418.72
Perimeter (mm) :	316.89
Bounding Box - X (mm) :	-36.38 to 23.63
Bounding Box - Y (mm) :	-25.63 to 19.37
Centroid - X (mm) :	0.00
Centroid - Y (mm) :	0.00
Moments of inertia - X (mm ⁴) :	13813.18
Moments of inertia - Y (mm ⁴) :	164759.88
Product of inertia - XY (mm ⁴) :	23340.90
Radius of gyration - X (mm) :	6.72
Radius of gyration - Y (mm) :	19.83
Principal moments along X-Y (mm ⁴) :	27832.03 along (0.99 -0.17)
Principal moments along Y-X (mm ⁴) :	166860.05 along (0.17 0.99)
Elastic Modulus - E _x (mm ²) :	1 / y-max= 1241.01
Elastic Modulus - E _y (mm ²) :	1 / x-max= 4507.70

PROPERTIES

MEMBER : IW-07
GRADE : 6063-T6
FINISH : PVF2 3-COATING

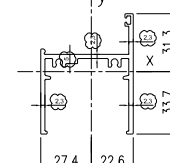

REGIONS	
MISS PROPERTIES (UNIT)	VALUES
Area (mm ²) :	486.03
Perimeter (mm) :	371.76
Bounding Box - X (mm) :	-27.35 to 23.65
Bounding Box - Y (mm) :	-33.68 to 33.32
Centroid - X (mm) :	0.00
Centroid - Y (mm) :	0.00
Moments of inertia - X (mm ⁴) :	100064.11
Moments of inertia - Y (mm ⁴) :	199447.02
Product of inertia - XY (mm ⁴) :	-27553.98
Radius of gyration - X (mm) :	14.64
Radius of gyration - Y (mm) :	20.07
Principal moments along X-Y (mm ⁴) :	98641.50 along (0.97 0.26)
Principal moments along Y-X (mm ⁴) :	206869.53 along (-0.26 0.97)
Elastic Modulus - E _x (mm ²) :	1 / y-max= 3148.84
Elastic Modulus - E _y (mm ²) :	1 / x-max= 2292.10

B.D. REF :

CLIENT :



ARCHITECT :



MAIN CONTRACTOR :



STRUCTURAL ENGINEER :



FACADE CONSULTANT:



NOTE :

- ALL DIMENSIONS ARE IN mm.
- ALL ELEVATIONS ARE VIEWED FROM OUTSIDE.
- ALL DIMENSIONS TO BE VERIFIED ON SITE BEFORE FABRICATION.

LEGEND :

- X1 --- DETAIL MARK NO.
- X001 --- REFER SHEET NO.

- F.F.L. --- FINISHED FLOOR LEVEL
- S.F.L. --- STRUCTURAL FLOOR LEVEL
- R --- REVERSED DETAIL
- GLASS LEGEND

EGL-1 --- 8mm+12mm AIR GAP+8mm THK. I.G.U.
EGL-2 --- 10mm THK. CLEAR TEMPERED GLASS

A	NO.	DATE	REVISION	BY
11/09/2023			REVISION SUBJECT TO ALPHA COMMENT	IC

JOB NO. : J-856

PROJECT : PROPOSED DEVELOPMENT ABOVE LIGHT RAIL TIN WING STOP, TSWTL NO.23, AREA 33, TIN SHUI WAI, N.T.

TITLE : DIE LIST FOR IN-SITU LOUVER

DATE : 02-Aug-21 SCALE : 1:40

DRAWN BY : Ivan CHECKED BY :



DWG NO. : J856-SD-LV-1001 REV. : A

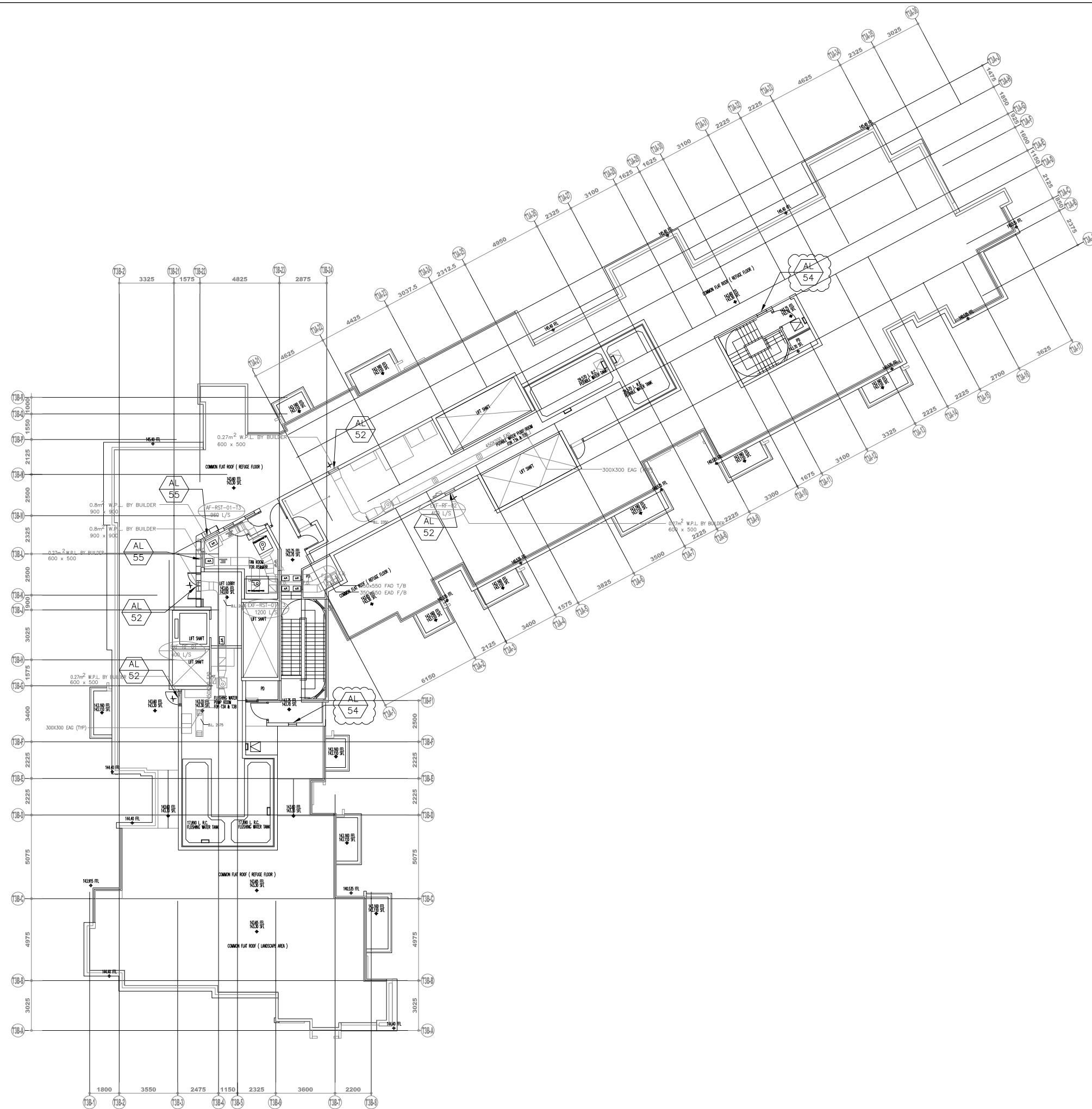

B.D. REF :

CLIENT :

SUN HUNG KAI
REAL ESTATE AGENCY LTD.
42/F SUN HUNG KAI CENTRE, WANCHAI, HONGKONG

ARCHITECT :

lwk&partners
architects

MAIN CONTRACTOR :

Yee Fai Building Contractors Ltd.

STRUCTURAL ENGINEER :

ARUP

FAÇADE CONSULTANT:

ALPHA CONSULTING LIMITED
Steel Structure & Façade Specialist

NOTE :

1. ALL DIMENSIONS ARE IN mm.
2. ALL ELEVATIONS ARE VIEWED FROM OUTSIDE.
3. ALL DIMENSIONS TO BE VERIFIED ON SITE BEFORE FABRICATION.

LEGEND :

- x1 — DETAIL MARK NO.
- x001 — REFER SHEET NO.

1. F.F.L. — FINISHED FLOOR LEVEL
2. S.F.L. — STRUCTURAL FLOOR LEVEL
3. (R) — REVERSED DETAIL
4. GLASS LEGEND

EGL-1 -- 8mm+12mm AIR GAP+8mm THK. I.G.U.
EGL-2 -- 10mm THK. CLEAR TEMPERED GLASS

NO.	DATE	REVISED	BY
C	11/09/2023	REVISION SUBJECT TO ARCH.COMMENT	ivan
B	09/08/2023	REVISION SUBJECT TO E&M COMMENT	ivan
A	08/06/2023	REVISION SUBJECT TO ARCH.COMMENT	ivan

JOB NO. : J-856

PROJECT : PROPOSED DEVELOPMENT ABOVE LIGHT RAIL TIN WING STOP, TSWL NO.23, AREA 33, TIN SHUI WAI, N.T.

TITLE : PLAN FOR IN-SITU LOUVER AT TOWER 3 R/F

DATE : 02-Aug-21 SCALE : 1:40

DRAWN BY : Ivan CHECKED BY :

美特鋁質有限公司
MIDI ALUMINIUM FABRICATOR LTD.
Units 6-8, Sunray Industrial Centre, 1/F
610 Cha Kwo Ling Road, Kowloon
Tel: 23489211-4 Fax: (852) 2727666

DWG NO. : J856-SD-LV-3307 REV. : C

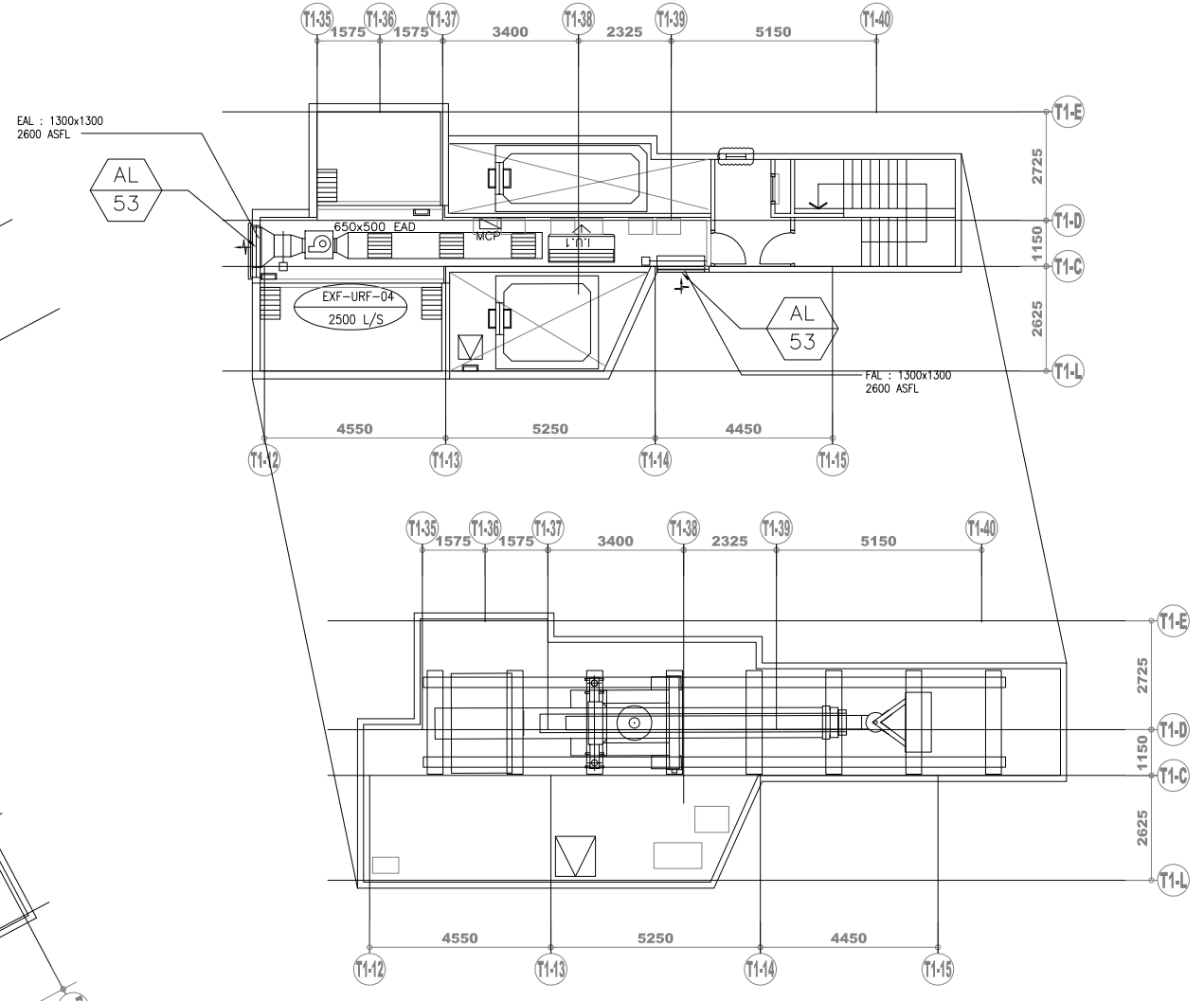
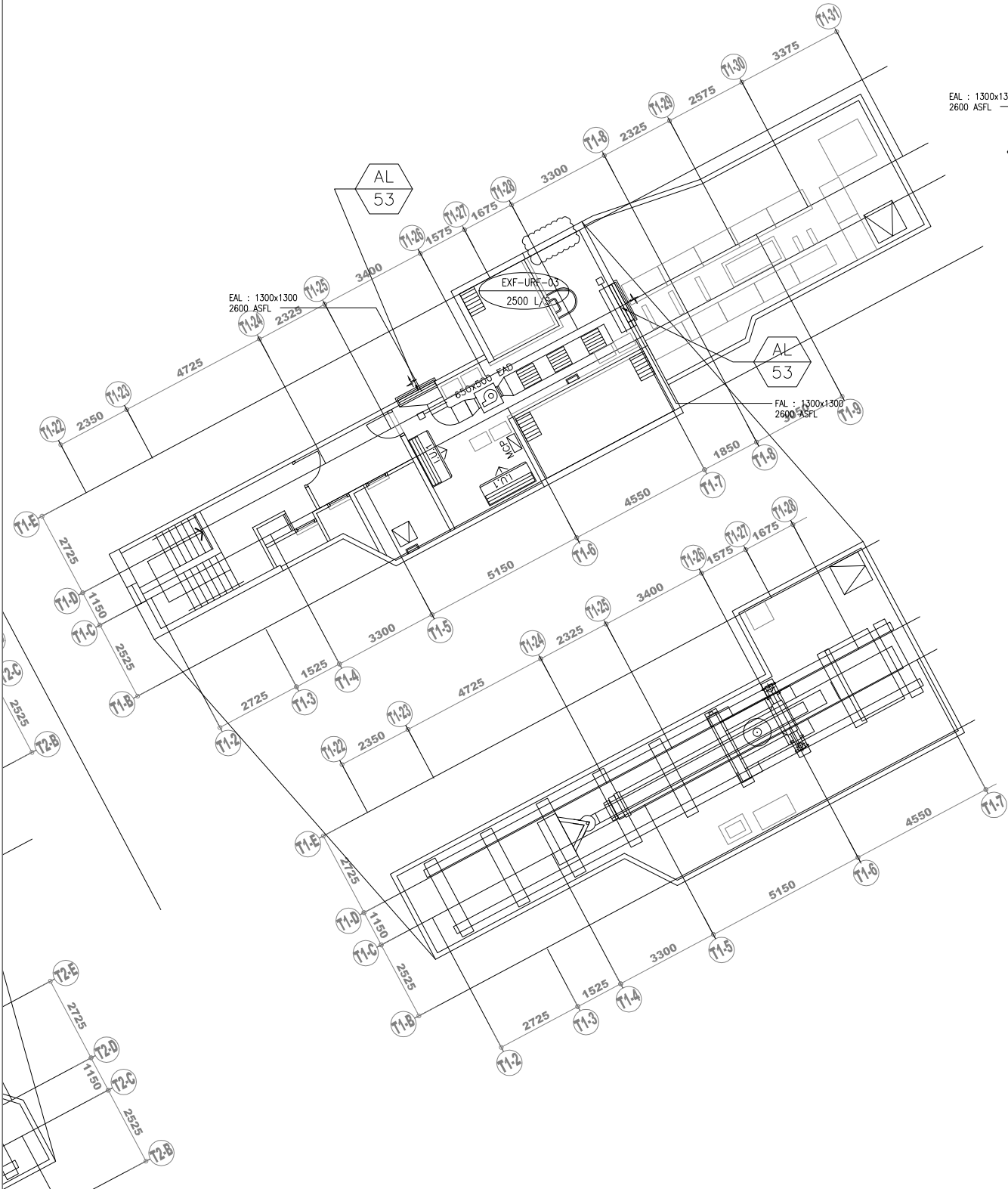

B.D. REF :

CLIENT :
SUN HUNG KAI
 REAL ESTATE AGENCY LTD.
 42/F SUN HUNG KAI CENTRE, WANCHAI, HONGKONG

ARCHITECT :
lwk&partners
 architects

MAIN CONTRACTOR :
Yee Fai Building Contractors Ltd.

STRUCTURAL ENGINEER :
ARUP

FAÇADE CONSULTANT:
ALPHA CONSULTING LIMITED
 Steel Structure & Façade Specialist

NOTE :
 1. ALL DIMENSIONS ARE IN mm.
 2. ALL ELEVATIONS ARE VIEWED FROM OUTSIDE.
 3. ALL DIMENSIONS TO BE VERIFIED ON SITE BEFORE FABRICATION.

LEGEND :
 x1 — DETAIL MARK NO.
 x001 — REFER SHEET NO.
 1. F.F.L. -- FINISHED FLOOR LEVEL
 2. S.F.L. -- STRUCTURAL FLOOR LEVEL
 3. (R) -- REVERSED DETAIL
 4. GLASS LEGEND
 EGL-1 -- 8mm+12mm AIR GAP+8mm THK. I.G.U.
 EGL-2 -- 10mm THK. CLEAR TEMPERED GLASS

NO.	DATE	REVISION	BY
A	08/06/2022	REVISION SUBJECT TO ARCH.COMMENT	Ivan

JOB NO. : J-856
 PROJECT : PROPOSED DEVELOPMENT ABOVE LIGHT RAIL TIN WING STOP, TSWL NO.23, AREA 33, TIN SHUI WAI, N.T.

TITLE : PLAN FOR IN-SITU LOUVER AT TOWER 1 R/F

DATE : 02-Aug-21 SCALE : 1:40
 DRAWN BY : Ivan CHECKED BY :

美特鋁質有限公司
MIDI ALUMINIUM FABRICATOR LTD.
 Units 6-8, Sunray Industrial Centre, 1/F
 610 Cha Kwo Ling Road, Kowloon
 Tel:23489211-4 Fax:(852)2727666

DWG NO. : J856-SD-LV-3108 REV. : A

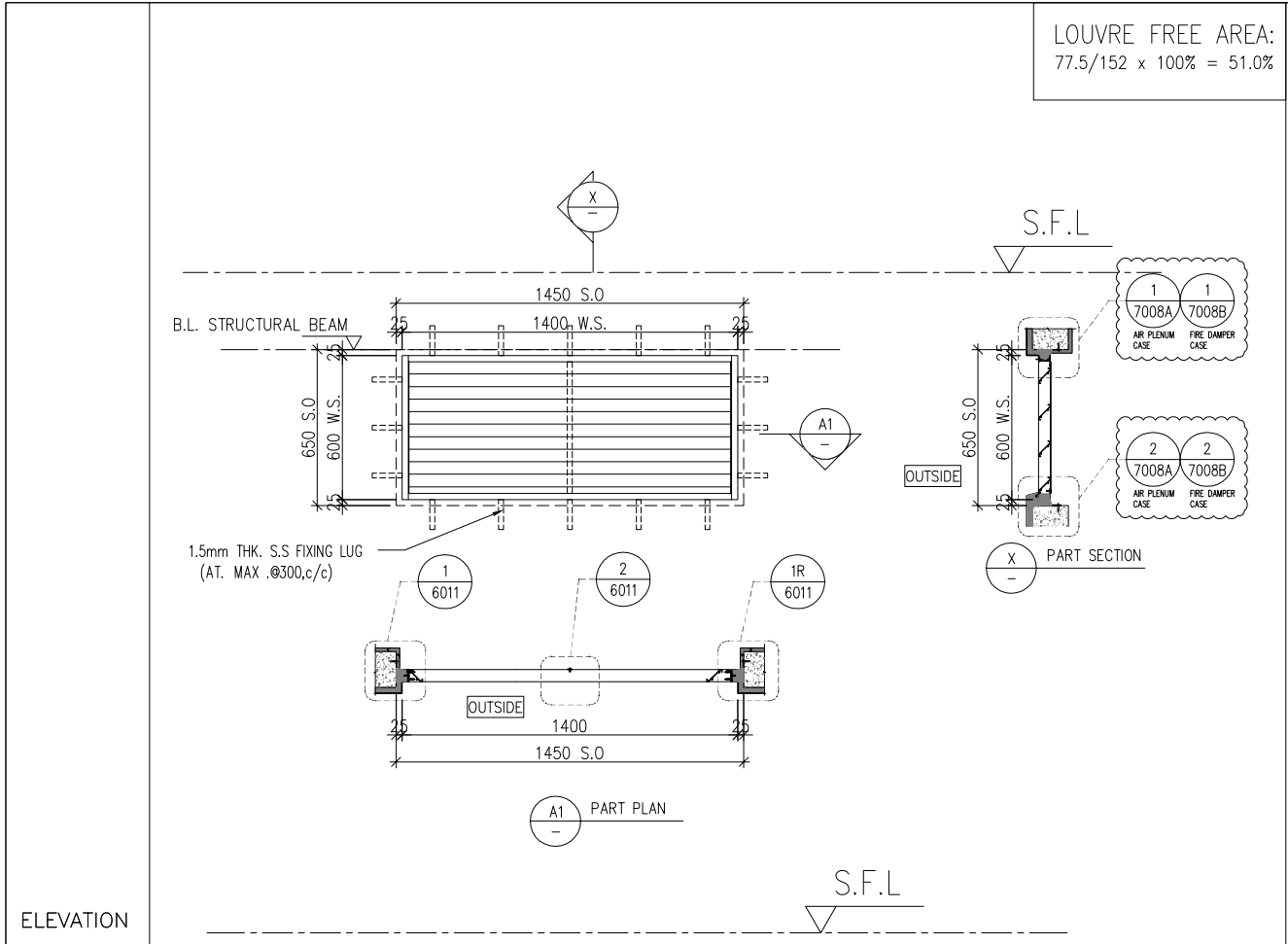

ELEVATION

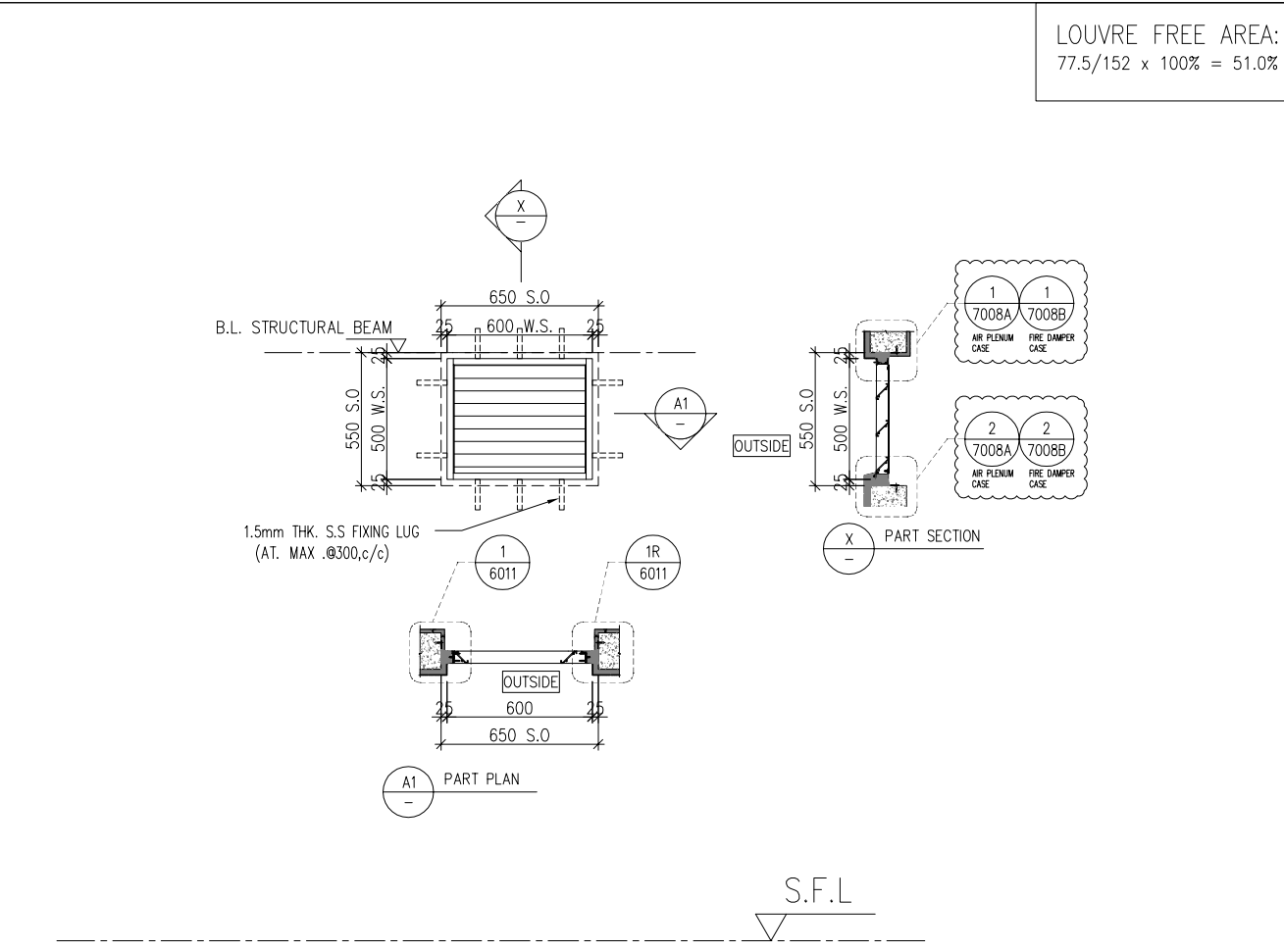

B.D. REF :

CLIENT :
 SUN HUNG KAI REAL ESTATE AGENCY LTD.
 42/F SUN HUNG KAI CENTRE, WANCHAI, HONGKONG

ARCHITECT :
 IWK&partners architects

MAIN CONTRACTOR :
 怡輝建築有限公司 Yee Fai Building Contractors Ltd.

STRUCTURAL ENGINEER :
 ARUP

FACADE CONSULTANT:
 ALPHA CONSULTING LIMITED
 Steel Structure & Facade Specialist

NOTE :
 1. ALL DIMENSIONS ARE IN mm.
 2. ALL ELEVATIONS ARE VIEWED FROM OUTSIDE.
 3. ALL DIMENSIONS TO BE VERIFIED ON SITE BEFORE FABRICATION.

LEGEND :
 X1 -- DETAIL MARK NO.
 X001 -- REFER SHEET NO.

1. F.F.L. -- FINISHED FLOOR LEVEL
 2. S.F.L. -- STRUCTURAL FLOOR LEVEL
 3. (R) -- REVERSED DETAIL
 4. GLASS LEGEND
 EGL-1 -- 8mm+12mm AIR GAP+8mm THK. I.G.U.
 EGL-2 -- 10mm THK. CLEAR TEMPERED GLASS

NO.	DATE	REVISED	BY
B	09/08/2023	REVISION SUBJECT TO E&M COMMENT	IC
A	08/06/2023	REVISION SUBJECT TO ARCH.COMMENT	IC

JOB NO. : J-856

PROJECT : PROPOSED DEVELOPMENT ABOVE LIGHT RAIL TIN WING STOP, TSWTL NO.23, AREA 33, TIN SHUI WAI, N.T.

TITLE : LOUVER SCHEDULE FOR TOWER IN-SITU LOUVER

DATE : 06-Aug-21 SCALE : 1:40

DRAWN BY : Ivan CHECKED BY :

美特鋁質有限公司
 MIDI ALUMINIUM FABRICATOR LTD.
 Units 6-8, Sunray Industrial Centre, 1/F
 610 Cha Kwo Ling Road, Kowloon
 Tel: 23489211-4 Fax: (852) 2727666

DWG NO. : J856-SD-LV-5001 REV. : B

T1	R/F: FAN ROOM FOR RS&MRR	1 NO.
T2		1 NO.

T3	R/F POTABLE WATER PUMP ROOM FOR T3A & T3B	2 NOS.
	R/F: LIFT LOBBY	1 NO.
	R/F: FLUSHING WATER PUMP ROOM FOR T3A & T3B	1 NO.

WINDOW MARK		
LOCATION		
SECTION	50mm ALUM. SECTION	50mm ALUM. SECTION
GLAZING	ALUM. LOUVER BLADE COLOR CODE: MATT BLACK FREE AREA: 51%	ALUM. LOUVER BLADE COLOUR CODE: MATT BLACK FREE AREA: 51%
QUANTITY	2 NOS. (TUC40577SC-3)	4 NOS. (TUC40577SC-3)
REMARKS	SS WIRE MESH	SS WIRE MESH

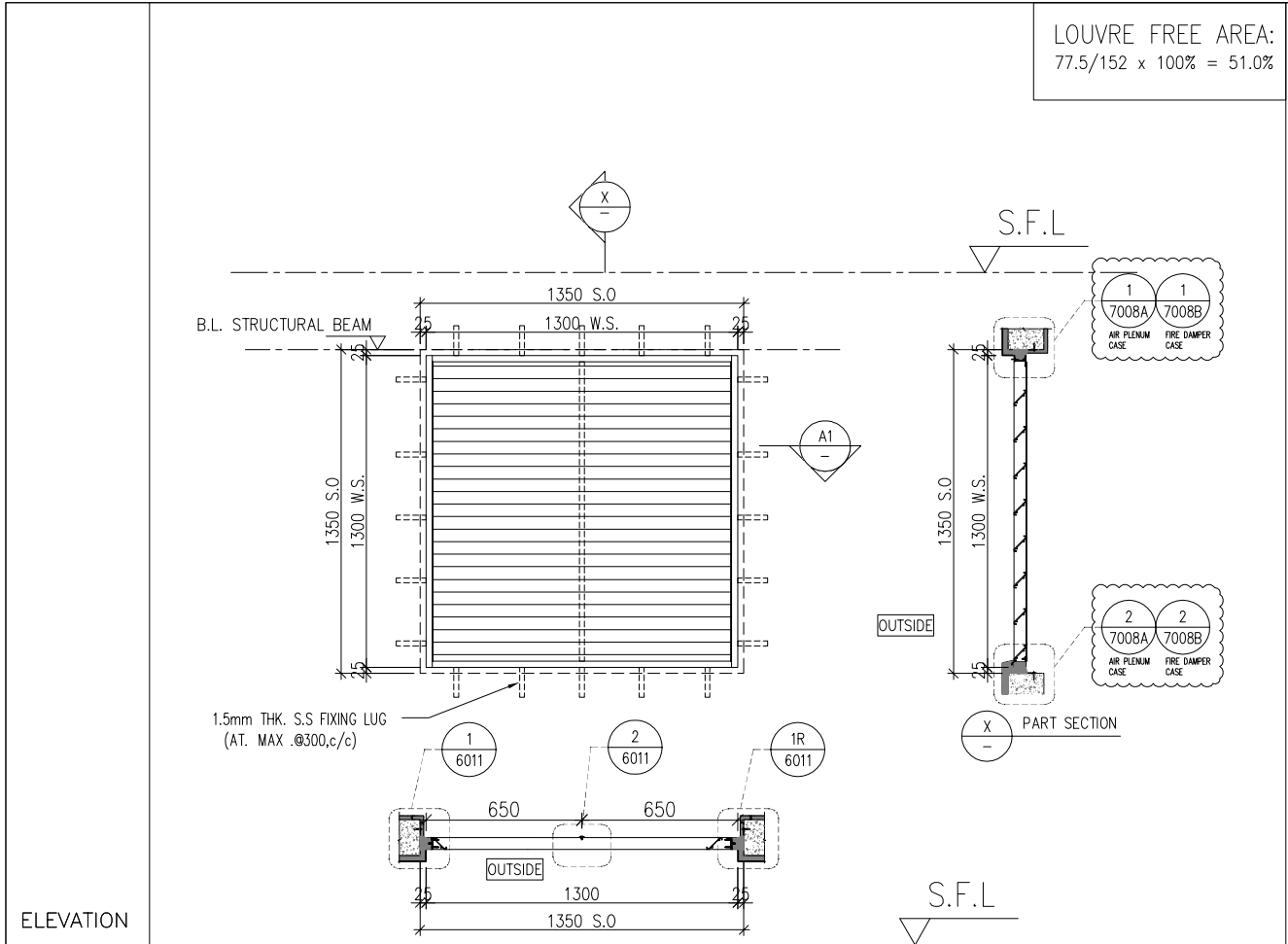

LOUVRE FREE AREA:
77.5/152 x 100% = 51.0%

ELEVATION

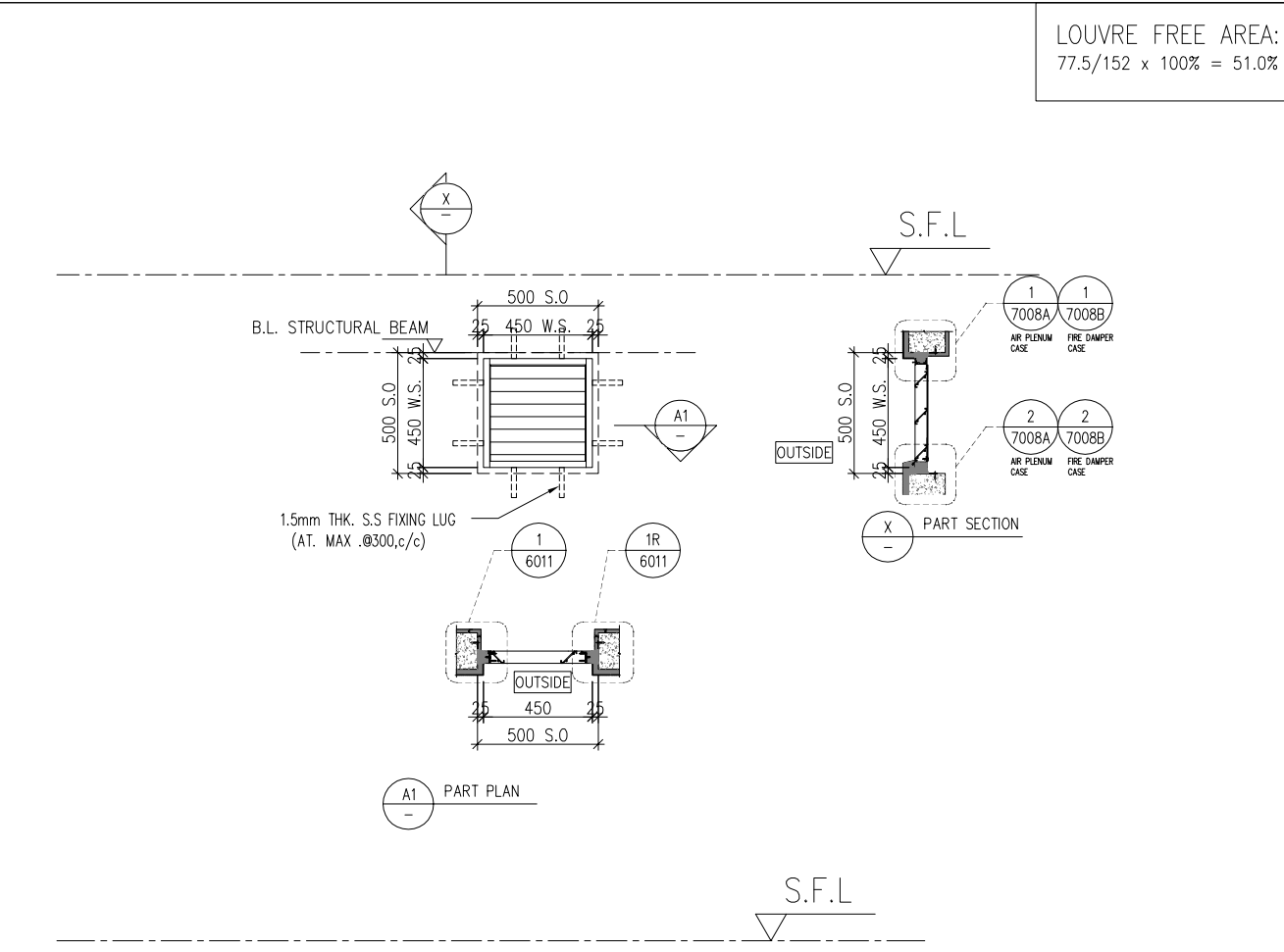

LOUVRE FREE AREA:
77.5/152 x 100% = 51.0%

ELEVATION

WINDOW MARK	AL 53
LOCATION	
SECTION	50mm ALUM. SECTION
GLAZING	ALUM. LOUVER BLADE COLOUR CODE: MATT BLACK FREE AREA: 51%
QUANTITY	12 NOS. (TUC40577SC-3)
REMARKS	SS WIRE MESH

T1	R/F: FLUSHING WATER PUMP ROOM	2 NOS.
	R/F: POTABLE WATER PUMP ROOM	2 NOS.
T2	R/F: FLUSHING WATER PUMP ROOM	2 NOS.
	R/F: POTABLE WATER PUMP ROOM	2 NOS.
T3	R/F: FOR STARCASE TOP VENT(ST07)	1 NO.
	R/F: FOR STARCASE TOP VENT(ST05)	1 NO.

WINDOW MARK	AL 54
LOCATION	
SECTION	50mm ALUM. SECTION
GLAZING	ALUM. LOUVER BLADE COLOUR CODE: MATT BLACK FREE AREA: 51%
QUANTITY	8 NOS. (TUC40577SC-3)
REMARKS	SS WIRE MESH

B.D. REF :

CLIENT :
SUN HUNG KAI
REAL ESTATE AGENCY LTD.
42/F SUN HUNG KAI CENTRE, WANCHAI, HONGKONG

ARCHITECT :
lwk&partners
architects

MAIN CONTRACTOR :
Yee Fai Building Contractors Ltd.

STRUCTURAL ENGINEER :
ARUP

FAÇADE CONSULTANT:
ALPHA CONSULTING LIMITED
Steel Structure & Façade Specialist

NOTE :

- ALL DIMENSIONS ARE IN mm.
- ALL ELEVATIONS ARE VIEWED FROM OUTSIDE.
- ALL DIMENSIONS TO BE VERIFIED ON SITE BEFORE FABRICATION.

LEGEND :

X1 — DETAIL MARK NO.
X001 — REFER SHEET NO.

- F.F.L. -- FINISHED FLOOR LEVEL
- S.F.L. -- STRUCTURAL FLOOR LEVEL
- (R) -- REVERSED DETAIL
- GLASS LEGEND
EGL-1 -- 8mm+12mm AIR GAP+8mm THK. I.G.U.
EGL-2 -- 10mm THK. CLEAR TEMPERED GLASS

NO.	DATE	REVISED	BY
C	07/09/2023	REVISION SUBJECT TO E&M COMMENT	IC
B	09/08/2023	REVISION SUBJECT TO E&M COMMENT	IC
A	08/06/2023	REVISION SUBJECT TO ARCH.COMMENT	IC

JOB NO. : J-856

PROJECT :
PROPOSED DEVELOPMENT ABOVE
LIGHT RAIL TIN WING STOP, TSWTL
NO.23, AREA 33, TIN SHUI WAI, N.T.

TITLE :
LOUVER SCHEDULE FOR
TOWER IN-SITU LOUVER

DATE : 06-Aug-21 SCALE : 1:40

DRAWN BY : Ivan CHECKED BY :

美特鋁質有限公司
MIDI ALUMINIUM FABRICATOR LTD.
Units 6-8, Sunray Industrial Centre, 1/F
610 Cha Kwo Ling Road, Kowloon
Tel: 23489211-4 Fax: (852) 2727666

DWG NO. : J856-SD-LV-5002 REV. : C

ELEVATION

LOUVRE FREE AREA:
77.5/152 x 100% = 51.0%

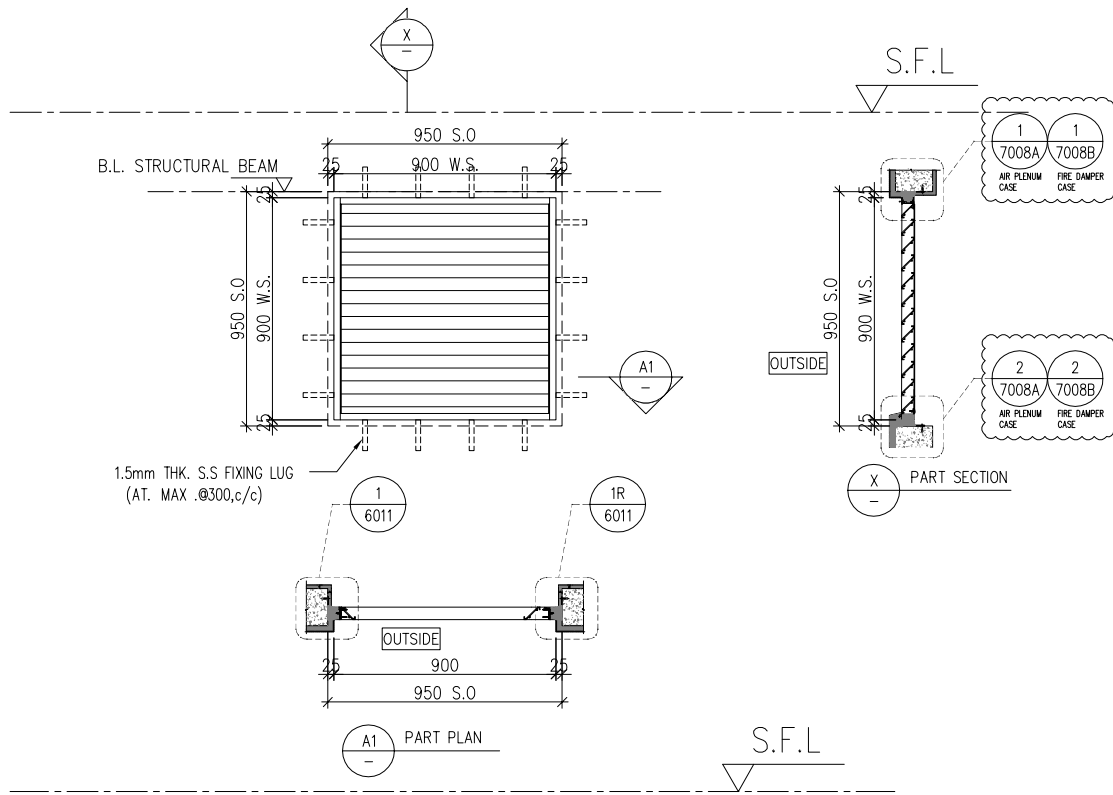

B.D. REF :

CLIENT :
SUN HUNG KAI
REAL ESTATE AGENCY LTD.
42/F SUN HUNG KAI CENTRE, WANCHAI, HONGKONG

ARCHITECT :
lwk&partners
architects

MAIN CONTRACTOR :
Yee Fai Building Contractors Ltd.

STRUCTURAL ENGINEER :
ARUP

FACADE CONSULTANT:
ALPHA CONSULTING LIMITED
Steel Structure & Facade Specialist

NOTE :
1. ALL DIMENSIONS ARE IN mm.
2. ALL ELEVATIONS ARE VIEWED FROM OUTSIDE.
3. ALL DIMENSIONS TO BE VERIFIED ON SITE BEFORE FABRICATION.

LEGEND :
X1 -- DETAIL MARK NO.
X001 -- REFER SHEET NO.

1. F.F.L. -- FINISHED FLOOR LEVEL
2. S.F.L. -- STRUCTURAL FLOOR LEVEL
3. (R) -- REVERSED DETAIL
4. GLASS LEGEND
EGL-1 -- 8mm+12mm AIR GAP+8mm THK. I.G.U.
EGL-2 -- 10mm THK. CLEAR TEMPERED GLASS

NO.	DATE	REVISED	BY
A	09/08/2023	REVISION SUBJECT TO E&M COMMENT	IC

JOB NO. : J-856
PROJECT : PROPOSED DEVELOPMENT ABOVE LIGHT RAIL TIN WING STOP, TSWTL NO.23, AREA 33, TIN SHUI WAI, N.T.

TITLE : LOUVER SCHEDULE FOR TOWER IN-SITU LOUVER

DATE : 06-Aug-21 SCALE : 1:40
DRAWN BY : Ivan CHECKED BY :

美特鋁質有限公司
MIDI ALUMINIUM FABRICATOR LTD.
Units 6-8, Sunray Industrial Centre, 1/F
610 Cha Kwo Ling Road, Kowloon
Tel: 23489211-4 Fax: (852) 2727666
DWG NO. : J856-SD-LV-5003 REV. : A

T3 R/F: POTABLE WATER PUMP ROOM FOR T3B & T3B 1 NO.
R/F: FAN ROOM FOR RS & MRR 2 NOS.

WINDOW MARK
AL 55

LOCATION
SECTION 50mm ALUM. SECTION
GLAZING ALUM. LOUVER BLADE COLOUR CODE: MATT BLACK FREE AREA: 51%
QUANTITY 2 NOS. (TUC40577SC-3)
REMARKS SS WIRE MESH

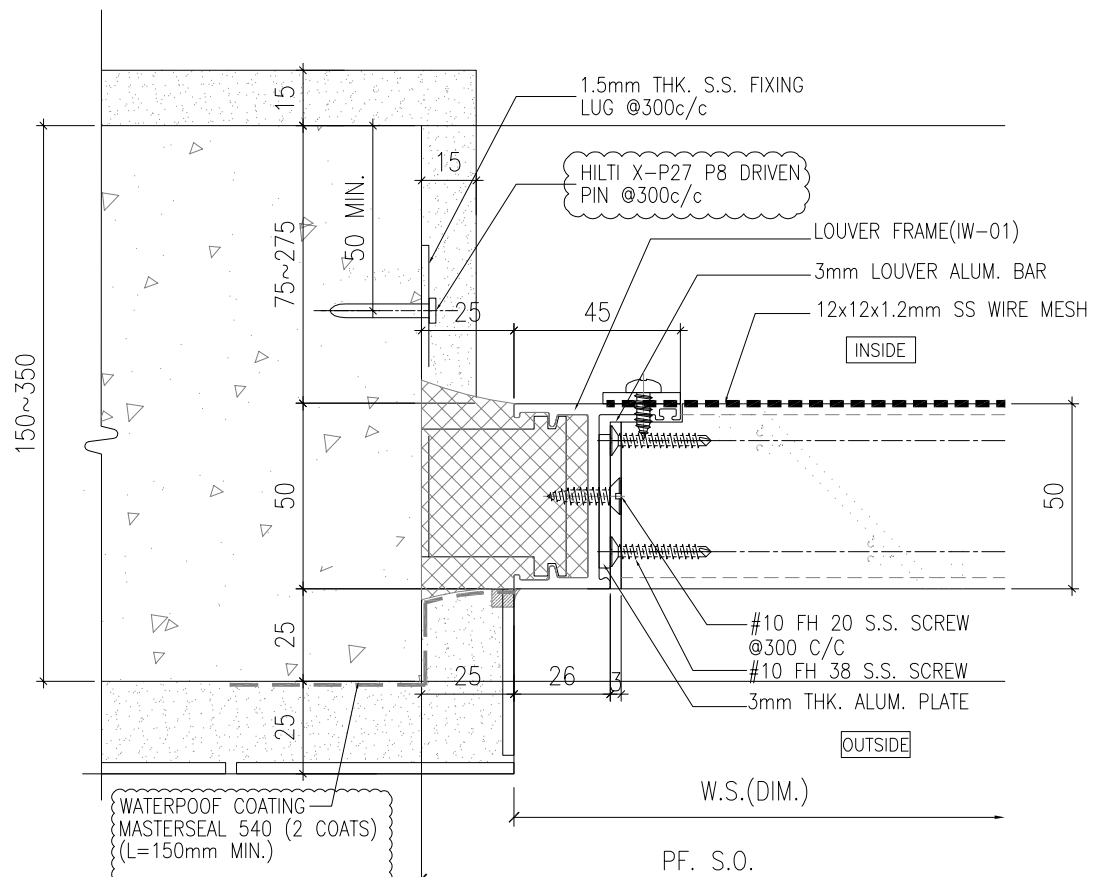

1
-
HORIZONTAL DETAIL
SCALE 1:2

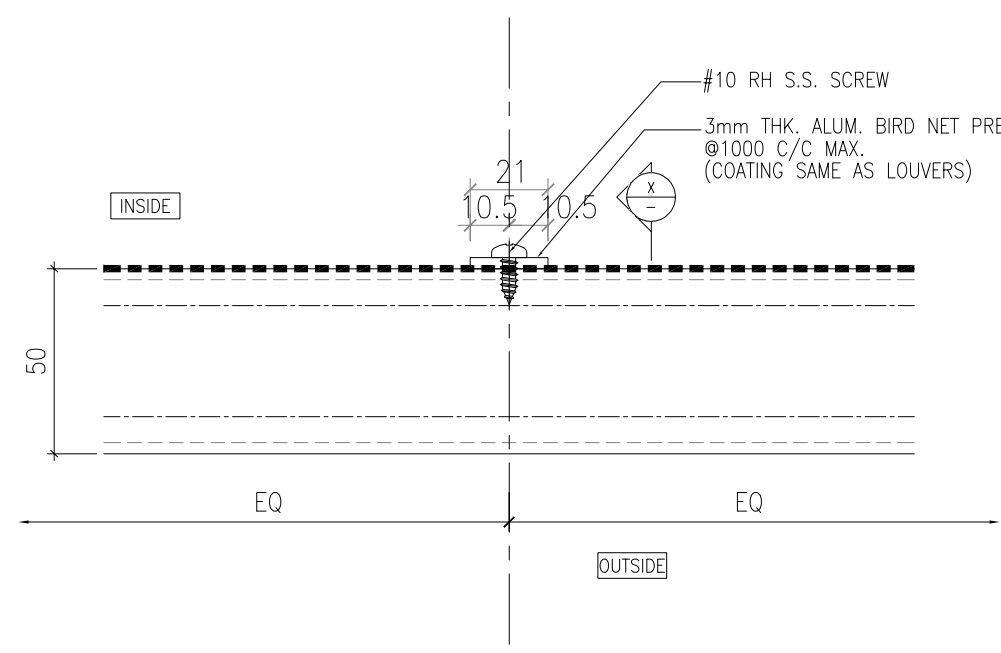

2
-
HORIZONTAL DETAIL
SCALE 1:2

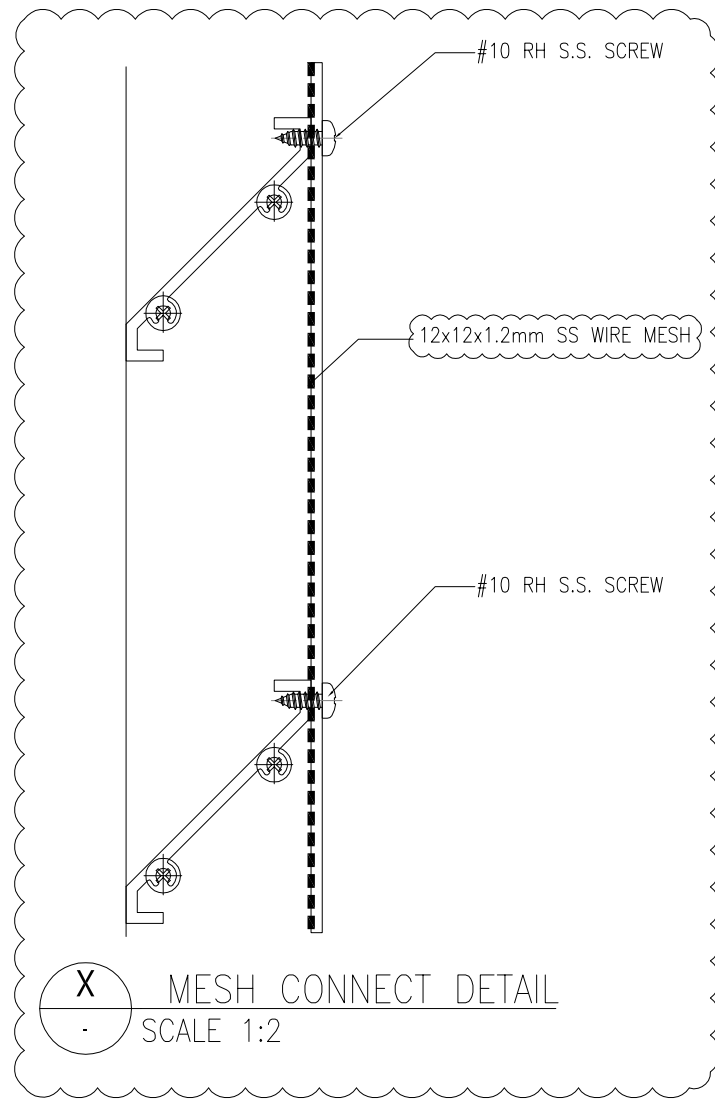

X
-
MESH CONNECT DETAIL
SCALE 1:2

B.D. REF :

CLIENT :
SUN HUNG KAI
REAL ESTATE AGENCY LTD.
42/F SUN HUNG KAI CENTRE, WANCHAI, HONGKONG

ARCHITECT :
lwk&partners
architects

MAIN CONTRACTOR :
Yee Fai Building Contractors Ltd.

STRUCTURAL ENGINEER :
ARUP

FACADE CONSULTANT:
ALPHA CONSULTING LIMITED
Steel Structure & Facade Specialist

NOTE :
1. ALL DIMENSIONS ARE IN mm.
2. ALL ELEVATIONS ARE VIEWED FROM OUTSIDE.
3. ALL DIMENSIONS TO BE VERIFIED ON SITE BEFORE FABRICATION.

LEGEND :
X1 - DETAIL MARK NO.
X001 - REFER SHEET NO.
1. F.F.L. -- FINISHED FLOOR LEVEL
2. S.F.L. -- STRUCTURAL FLOOR LEVEL
3. (R) -- REVERSED DETAIL
4. GLASS LEGEND
EGL-1 -- 8mm+12mm AIR GAP+8mm THK. I.G.U.
EGL-2 -- 10mm THK. CLEAR TEMPERED GLASS

B	09/08/2023	GENERAL REVISION	IC
A	08/06/2023	GENERAL REVISION	IC
NO.	DATE	REVISED	BY

JOB NO. : J-856
PROJECT : PROPOSED DEVELOPMENT ABOVE LIGHT RAIL TIN WING STOP, TSWTL NO.23, AREA 33, TIN SHUI WAI, N.T.

TITLE : TYPICAL DETAILS FOR IN-SITU LOUVER

DATE : 20-Jun-22 SCALE : 1:40
DRAWN BY : Ivan CHECKED BY :

美特鋁質有限公司
MIDI ALUMINIUM FABRICATOR LTD.
Units 6-8, Sunray Industrial Centre, 1/F
610 Cha Kwo Ling Road, Kowloon
Tel: 23489211-4 Fax: (852) 27727666

DWG NO. : J856-SD-LV-6011 REV. : B

B.D. REF :

CLIENT :

SUN HUNG KAI
REAL ESTATE AGENCY LTD.
42/F, SUN HUNG KAI CENTRE, WANCHAI, HONGKONG

ARCHITECT :

IWK&partners
A R C H I T E C T S

MAIN CONTRACTOR :

怡輝建築有限公司
Yee Fai Building Contractors Ltd.

STRUCTURAL ENGINEER :

ARUP

FAÇADE CONSULTANT:

ALPHA CONSULTING LIMITED
Steel Structure & Façade Specialist

NOTE:

1. ALL DIMENSIONS ARE IN mm.
2. ALL ELEVATIONS ARE VIEWED FROM OUTSIDE.
3. ALL DIMENSIONS TO BE VERIFIED ON SITE BEFORE FABRICATION.

LEGEND :

(X1) — DETAIL MARK NO.
(X001) — REFER SHEET NO.

1. F.F.L. --- FINISHED FLOOR LEVEL
2. S.F.L. --- STRUCTURAL FLOOR LEVEL
3. (R) --- REVERSED DETAIL

4. GLASS LEGEND

EGL-1 --- 8mm+12mm AIR GAP+8mm THK. I.G.U.
EGL-2 --- 10mm THK. CLEAR TEMPERED GLASS

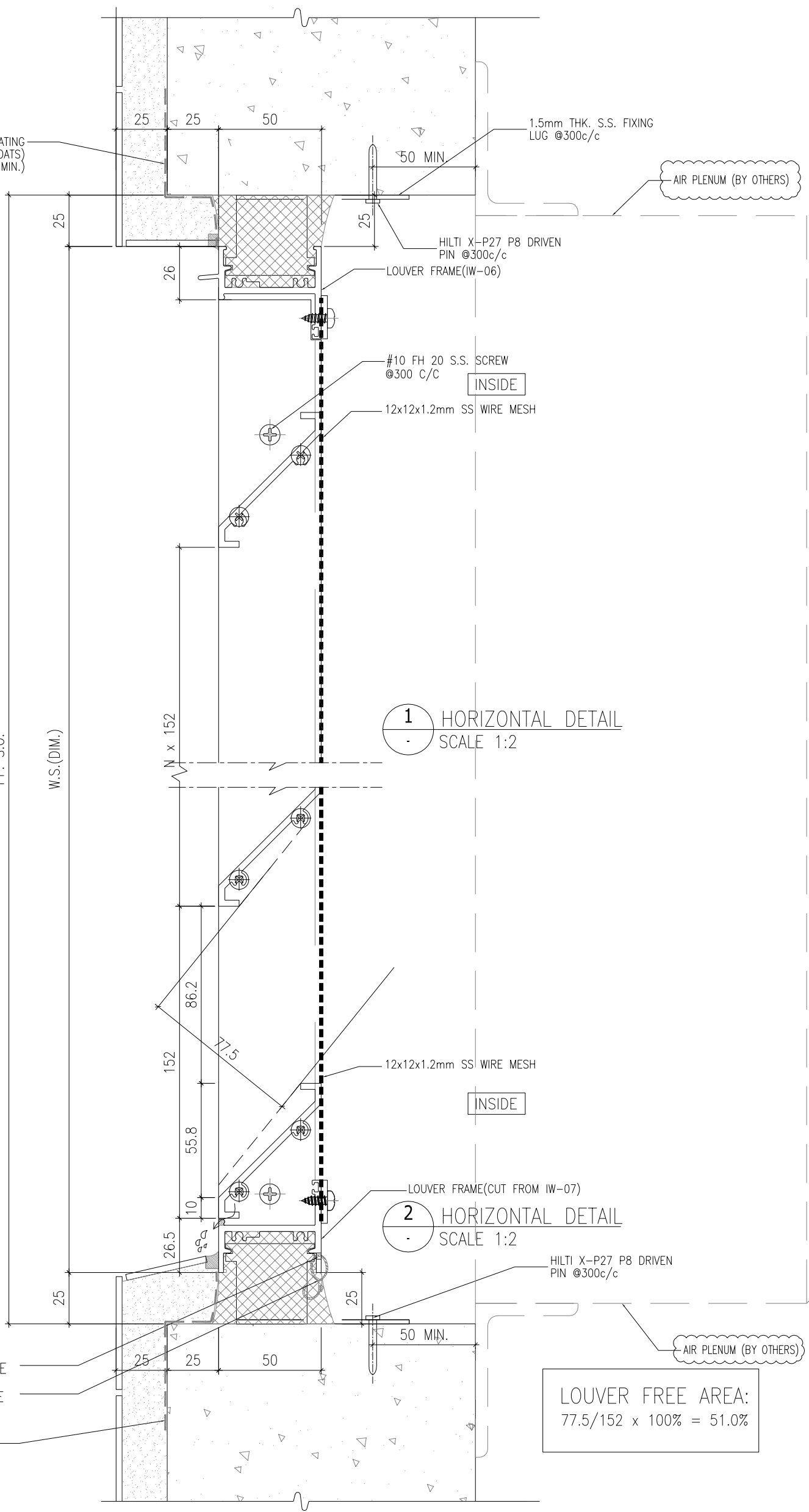

PF. S.O.

W.S.(DIM.)

OUTSIDE

INSIDE

OUTSIDE

INSIDE

TITLE :
TYPICAL DETAILS FOR
IN-SITU LOUVER

DATE : 02-Aug-21 SCALE : 1:40

DRAWN BY : Ivorn CHECKED BY :

MIDI ALUMINIUM FABRICATOR LTD.
Units 6-8, Sunray Industrial Centre, 1/F
610 Cho Kwo Ling Road, Kowloon
Tel:23489211-4 Fax:(852)27727666

DWG NO. : J856-SD-LV-7008A REV. : B

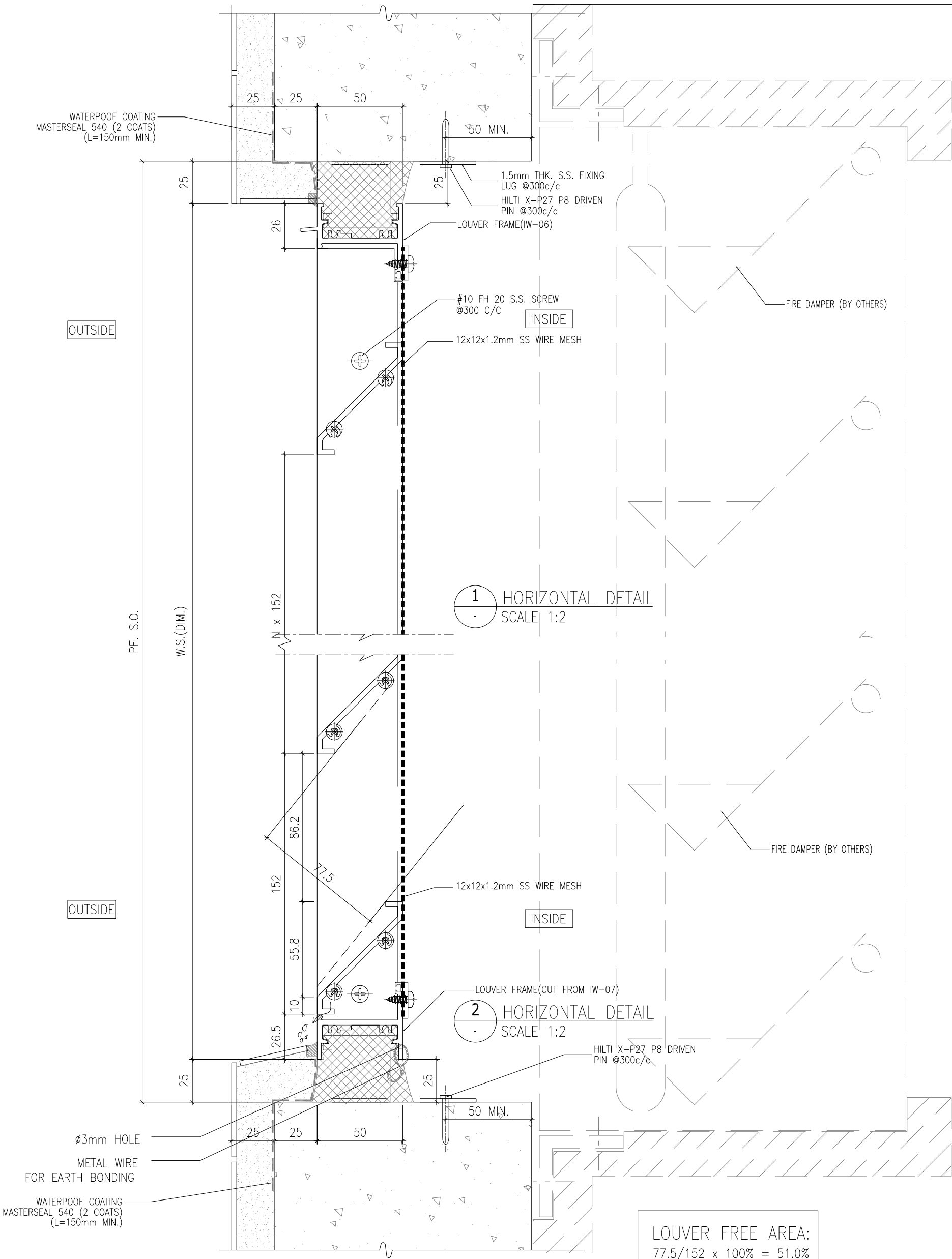

B.D. REF. :

CLIENT :

SUN HUNG KAI
REAL ESTATE AGENCY LTD.
42/F, SUN HUNG KAI CENTRE, WANCHAI, HONGKONG

ARCHITECT :

IWK&partners
ARCHITECTS

MAIN CONTRACTOR :

怡輝建築有限公司
Yee Fai Building Contractors Ltd.

STRUCTURAL ENGINEER :

ARUP

FAÇADE CONSULTANT :

ALPHA CONSULTING LIMITED
Steel Structure & Façade Specialist

NOTE :

1. ALL DIMENSIONS ARE IN mm.
2. ALL ELEVATIONS ARE VIEWED FROM OUTSIDE.
3. ALL DIMENSIONS TO BE VERIFIED ON SITE BEFORE FABRICATION.

LEGEND :

- (X1) — DETAIL MARK NO.
- (X001) — REFER SHEET NO.

1. F.F.L. --- FINISHED FLOOR LEVEL
2. S.F.L. --- STRUCTURAL FLOOR LEVEL
3. (R) --- REVERSED DETAIL

4. GLASS LEGEND

EGL-1 --- 8mm+12mm AIR GAP+8mm THK. I.G.U.

EGL-2 --- 10mm THK. CLEAR TEMPERED GLASS

NO.	DATE	REVISION	BY

JOB NO. : J-856

PROJECT : PROPOSED DEVELOPMENT ABOVE LIGHT RAIL TIN WING STOP, TSWTL NO.23, AREA 33, TIN SHUI WAI, N.T.

TITLE : TYPICAL DETAILS FOR IN-SITU LOUVER

DATE : 02-Aug-21 SCALE : 1:40

DRAWN BY : Ivorn CHECKED BY :

美特鋁質有限公司
MIDI ALUMINIUM FABRICATOR LTD.
Units 6-8, Sunny Industrial Centre, 1/F
610 Cho Kwo Ling Road, Kowloon
Tel: 23489211-4 Fax: (852) 27727666

DWG NO. : J856-SD-LV-7008B REV. : -

