



工程指示 / 要求簡箋 ENGINEER INSTRUCTIONS(E.I.)

工程指示編號:	EI- 6271G	修改版本:	G.
	HK- 1503		
工程編號:	J 856	工程名稱:	TSWTL23 天榮
收件人:	生統/林仁安	發件人:	Thomas Wong
工程項目:	CW 大貨SU層單元件拆圖檔 加工圖	日期:	04/07/2023

<input checked="" type="checkbox"/> 原合約工程包	<input type="checkbox"/> 原合約工程加 / 減賬 QT-	<input type="checkbox"/> 新工程報價 QT-
--	--	------------------------------------

信件批核號碼/圖紙參考編號:	批核模貝圖紙編號:
客戶指示附件:	管理內部批簽署:

<input type="checkbox"/> 初步鋁料 B.M.	<input type="checkbox"/> 加工拆圖, 然後生產	<input type="checkbox"/> 尺寸表
<input type="checkbox"/> 正式鋁料 B.M.	<input type="checkbox"/> 技術上資料/指示	<input type="checkbox"/> 報價
<input type="checkbox"/> 配件 B.M.	<input type="checkbox"/> 樣辦或貨品說明書	<input type="checkbox"/> 分判合約
<input type="checkbox"/> 其他:		

內容:
CW 大貨SU層單元件拆圖檔 加工圖

完成上列要求日期: 11/07/2023

國內

<input type="checkbox"/> 生產技術總監	<input type="checkbox"/> 連附件	<input checked="" type="checkbox"/> 技術部	<input checked="" type="checkbox"/> 連附件	<input type="checkbox"/> 生產部	<input type="checkbox"/> 連附件
<input type="checkbox"/> 採購部	<input type="checkbox"/> 連附件	<input checked="" type="checkbox"/> 生產統籌部	<input checked="" type="checkbox"/> 連附件	<input type="checkbox"/> 報關組	<input type="checkbox"/> 連附件
<input type="checkbox"/> 質檢部	<input type="checkbox"/> 連附件	<input type="checkbox"/> 會計部	<input type="checkbox"/> 連附件	<input type="checkbox"/> 機械設計部	<input type="checkbox"/> 連附件
<input type="checkbox"/> 香港辦	<input type="checkbox"/> 連附件	<input checked="" type="checkbox"/> 其他: 林仁安			

香港

<input type="checkbox"/> 行政部	<input type="checkbox"/> 連附件	<input type="checkbox"/> 會計部	<input type="checkbox"/> 連附件	<input type="checkbox"/> 統籌部	<input type="checkbox"/> 連附件	<input type="checkbox"/> 工程部	<input type="checkbox"/> 連附件
<input type="checkbox"/> 採購部	<input type="checkbox"/> 連附件	<input type="checkbox"/> QS部	<input type="checkbox"/> 連附件	<input type="checkbox"/> 地盤管理	<input type="checkbox"/> 連附件	<input type="checkbox"/> 維修部	<input type="checkbox"/> 連附件

*發件人簽署:	瑋	*組別成員批核簽署:	
傳遞編號:		項目經理簽署:	

鋁材開料總表

工程號碼: J856 工程名稱: 天榮站

序號	鋁料編號	名稱	表面處理		開料長度	實用長料總數量		浪費率(%)
			顏色	層厚		支數	長度	
1	AC01				6500	40	260000	6.00
2	AD06				5000	22	110000	10.88
3	AJ03				5500	19	104500	3.88
4	AJ04				6500	12	78000	8.23
5	AM01				3000	27	81000	7.93
6	AM02				3000	26	78000	7.93
7	AM06				3200	1	3200	13.69
8	AT01				5500	14	77000	6.88
9	AT02				5500	14	77000	8.57
10	AT03				5500	10	55000	15.78
11	AT04				6000	4	24000	9.23
12	AT05				6000	5	30000	18.75
13	GS01				5300	4	21200	11.58
14	J60X38				6000	1	6000	77.33
15	MS01				5300	8	42400	6.13
16	X86364				3000	24	72000	7.93
17	X86365				3000	25	75000	7.93
18	X86367				3000	17	51000	7.93
19	X86371				6000	12	72000	0.75
20	X86372				5700	8	45600	12.72
21	X86374				5500	13	71500	8.90
22	X86375				5500	13	71500	8.90
23	X86412				5500	62	341000	2.82
24	AC02				6000	14	84000	8.60
25	JMA1069				5300	2	10600	48.30
26	WS01				6000	14	84000	8.81
27	WS03				6000	9	54000	9.91
28	X86370				6000	9	54000	6.36
29	AS01				5300	2	10600	39.62

送至: _____

由: _____

日期: _____

簡短說明: _____

共30頁 第1頁

打印日期: 2023/7/3 打印時間: 20:04

工程號碼:J856, 工程名稱:天榮站

開料長度:5300, 總長料支數:8, 總開料支數:120

鋸片厚度(mm):5, 料頭尾總切除(mm):100, 浪費率(%):6.13

鋁材開料清單 MS01

窗號	編號(用料狀況)	實用長度(長料開數)	需要 支數	開料 支數	長料 支數	餘料 支數	編號(剩餘長度)
MS01-P01	1-8	320.0	120	120	8	0	1-7@(0)x7 8@(2600)x1

工程號碼:J856, 工程名稱:天榮站

開料長度:5300, 總長料支數:2, 總開料支數:40

鋸片厚度(mm):5, 料頭尾總切除(mm):100, 浪費率(%):39.62

鋁材開料清單 AS01

窗號	編號(用料狀況)	實用長度(長料開數)	需要 支數	開料 支數	長料 支數	餘料 支數	編號(剩餘長度)
AS01-001	1-2	150.0	40	40	2	0	1@(85)x1 2@(4115)x1

工程號碼:J856, 工程名稱:天榮站

開料長度:5700, 總長料支數:8, 總開料支數:120

鋸片厚度(mm):5, 料頭尾總切除(mm):100, 浪費率(%):12.72

鋁材開料清單 X86372

窗號	編號(用料狀況)	實用長度(長料開數)	需要支數	開料支數	長料支數	餘料支數	編號(剩餘長度)
X86372-P02, X86372-P01, X86372-P02	(餘料)4, 1-8	320.0	120	120	8	1	4@(75)x1 1-3@(75)x3 4@(2675)x1 5-7@(75)x3 8@(5275)x1

工程號碼:J856, 工程名稱:天榮站

開料長度:6000, 總長料支數:9, 總開料支數:182

鋁材開料清單 X86370

鋸片厚度(mm):5, 料頭尾總切除(mm):100, 浪費率(%):6.36

窗號	編號(用料狀況)	實用長度(長料開數)	需要支數	開料支數	長料支數	餘料支數	編號(剩餘長度)
X86370-P01	(餘料)1	604.5	16	1	0	1	1@(370.5)x1
X86370-P01	2-3	604.5		15	2	0	2@(414.5)x1
X86370-P03	(餘料)3	560.5	34	3	0	1	3@(546.5)x1
X86370-P03	4-7	560.5		31	4	0	4-6@(245)x3 7@(5334.5)x1
X86370-P04-06, X86370-P04-07	(餘料)2-3, 7, 7	368.0	8	8	0	4	2@(41.5)x1 3@(173.5)x1 7@(4588.5)x1 7@(3096.5)x1
X86370-P04-05	(餘料)1, 7	350.5	16	9	0	2	1@(15)x1 7@(252.5)x1
X86370-P04-05	8	350.5		7	1	0	8@(3411.5)x1
X86370-P02	(餘料)8	289.5	16	11	0	1	8@(172)x1
X86370-P02	9	289.5		5	1	0	9@(4427.5)x1
X86370-P04-01	(餘料)4-7, 9	233.0	10	10	0	5	4-6@(7)x3 7@(14.5)x1 9@(2999.5)x1
X86370-K01	1	55.0	82	82	1	0	1@(980)x1

工程號碼:J856, 工程名稱:天榮站
開料長度:6000, 總長料支數:9, 總開料支數:66
鋸片厚度(mm):5, 料頭尾總切除(mm):100, 浪費率(%):9.91

鋁材開料清單 WS03

窗號	編號(用料狀況)	實用長度(長料開數)	需要支數	開料支數	長料支數	餘料支數	編號(剩餘長度)
WS03-P14	(餘料)1	900.0	4	2	0	1	1@(2280)x1
WS03-P13	1	900.0		2	1	0	1@(4090)x1
WS03-P15	(餘料)1	880.0	4	2	0	1	1@(510)x1
WS03-P16	2	880.0		2	1	0	2@(4130)x1
WS03-P11, WS03-P12	(餘料)2-3	865.0	16	6	0	2	2@(650)x1 3@(680)x1
WS03-P11, WS03-P12	3-4	865.0		10	2	0	3@(2420)x1
WS03-P01, WS03-P02, WS03-P03, WS03-P04, WS03-P05, WS03-P06	(餘料)2-8, 8	630.0	42	29	0	8	2@(15)x1 3-4@(45)x2 5-7@(185)x3 8@(1455)x1 8@(185)x1
WS03-P01, WS03-P02, WS03-P03, WS03-P04, WS03-P06	5-9	630.0		13	5	0	5@(3360)x1 6-8@(4630)x3 9@(3995)x1

工程號碼:J856, 工程名稱:天榮站

開料長度:6000, 總長料支數:14, 總開料支數:66

鋸片厚度(mm):5, 料頭尾總切除(mm):100, 浪費率(%):8.81

鋁材開料清單 WS01

窗號	編號(用料狀況)	實用長度(長料開數)	需要支數	開料支數	長料支數	餘料支數	編號(剩餘長度)
WS01-P02, WS01-P03	(餘料)4-5	1155.0	32	6	0	2	4-5@(100)x2
WS01-P01, WS01-P02, WS01-P03	1-7	1155.0		26	7	0	1-3@(100)x3 4@(4740)x1
WS01-P04, WS01-P05	(餘料)7, 10	1115.0	34	4	0	2	7@(220)x1 10@(300)x1
WS01-P04, WS01-P05	8-14	1115.0		30	7	0	8-9@(300)x2 10@(1420)x1 11-13@(300)x3 14@(4780)x1

工程號碼:J856, 工程名稱:天榮站

開料長度:5300, 總長料支數:2, 總開料支數:132

鋸片厚度(mm):5, 料頭尾總切除(mm):100, 浪費率(%):48.3

鋁材開料清單 JMA1069

窗號	編號(用料狀況)	實用長度(長料開數)	需要 支數	開料 支數	長料 支數	餘料 支數	編號(剩餘長度)
JS01-Q02, JS01-Q01, JS01-Q02	(餘料)1, 1-2	35.0	132	132	2	1	1@(0)x1 1@(2560)x1 2@(5120)x1

工程號碼:J856, 工程名稱:天榮站

開料長度:6000, 總長料支數:14, 總開料支數:66

鋸片厚度(mm):5, 料頭尾總切除(mm):100, 浪費率(%):8.6

鋁材開料清單 AC02

窗號	編號(用料狀況)	實用長度(長料開數)	需要支數	開料支數	長料支數	餘料支數	編號(剩餘長度)
AC02-E01R-1, AC02-E01-1, AC02-E01R-1	(餘料)7, 1-14	1137.0	66	66	14	1	7@(190)x1 1-6@(190)x6 7@(2474)x1 8-13@(190)x6 14@(4758)x1

鋁材開料清單 X86367

窗號	編號(用料狀況)	實用長度(長料開數)	需要 支數	開料 支數	長料 支數	餘料 支數	編號(剩餘長度)
X86367-SU01, X86367-SU02, X86367-SU03, X86367-SU04	1-17	2657.0	17	17	17	0	1-17@(238)x17

工程號碼:J856, 工程名稱:天榮站

開料長度:3000, 總長料支數:25, 總開料支數:25

鋸片厚度(mm):5, 料頭尾總切除(mm):100, 浪費率(%):7.93

鋁材開料清單 X86365

窗號	編號(用料狀況)	實用長度(長料開數)	需要支數	開料支數	長料支數	餘料支數	編號(剩餘長度)
X86365-SU01, X86365-SU02, X86365-SU03, X86365-SU04	1-25	2657.0	25	25	25	0	1-25@(238)x25

工程號碼:J856, 工程名稱:天榮站

開料長度:3000, 總長料支數:24, 總開料支數:24

鋸片厚度(mm):5, 料頭尾總切除(mm):100, 浪費率(%):7.93

鋁材開料清單 X86364

窗號	編號(用料狀況)	實用長度(長料開數)	需要 支數	開料 支數	長料 支數	餘料 支數	編號(剩餘長度)
X86364-SU01, X86364-SU02, X86364-SU03, X86364-SU04	1-24	2657.0	24	24	24	0	1-24@(238)x24

工程號碼:J856, 工程名稱:天榮站

開料長度:6000, 總長料支數:1, 總開料支數:63

鋁材開料清單 J60X38

鋸片厚度(mm):5, 料頭尾總切除(mm):100, 浪費率(%):77.33

窗號	編號(用料狀況)	實用長度(長料開數)	需要 支數	開料 支數	長料 支數	餘料 支數	編號(剩餘長度)
J60*38-002, J60*38-003, J60*38-001	(餘料)1, 1, 1	15.0	63	63	1	2	1@(4920)x1 1@(4640)x1 1@(5400)x1

鋁材開料清單 GS01

窗號	編號(用料狀況)	實用長度(長料開數)	需要 支數	開料 支數	長料 支數	餘料 支數	編號(剩餘長度)
GS01-K01	1-3	300.0	51	51	3	0	1-3@(15)x3
GS01-K02	4	150.0	18	18	1	0	4@(2410)x1

工程號碼:J856, 工程名稱:天榮站

開料長度:6000, 總長料支數:5, 總開料支數:33

鋁材開料清單 AT05

鋸片厚度(mm):5, 料頭尾總切除(mm):100, 浪費率(%):18.75

窗號	編號(用料狀況)	實用長度(長料開數)	需要支數	開料支數	長料支數	餘料支數	編號(剩餘長度)
AT05-SU02-03	(餘料)1	900.0	2	1	0	1	1@(550)x1
AT05-SU02-03	2	900.0		1	1	0	2@(4995)x1
AT05-SU02-04	(餘料)2	880.0	2	2	0	1	2@(3225)x1
AT05-SU02-02	(餘料)2	865.0	8	3	0	1	2@(615)x1
AT05-SU02-02	3	865.0		5	1	0	3@(1550)x1
AT05-SU02-01, AT05-SU03-01	(餘料)3-4	630.0	21	8	0	2	3@(280)x1 4@(185)x1
AT05-SU01-01, AT05-SU02-01, AT05-SU03-01	1, 4-5	630.0		13	3	0	1@(1455)x1 4-5@(3995)x2

工程號碼:J856, 工程名稱:天榮站

開料長度:6000, 總長料支數:4, 總開料支數:33

鋸片厚度(mm):5, 料頭尾總切除(mm):100, 浪費率(%):9.23

鋁材開料清單 AT04

窗號	編號(用料狀況)	實用長度(長料開數)	需要支數	開料支數	長料支數	餘料支數	編號(剩餘長度)
AT04-SU02-002, AT04-SU02-004	(餘料)1-2	682.5	10	4	0	2	1@(80)x1 2@(400)x1
AT04-SU02-002	2	682.5		6	1	0	2@(1775)x1
AT04-SU03-01	(餘料)3	630.0	21	4	0	1	3@(185)x1
AT04-SU01-01, AT04-SU02-003	1, 3-4	630.0		17	3	0	1@(1455)x1
AT04-SU02-003	(餘料)4	582.5	2	2	0	1	4@(1550)x1

工程號碼:J856, 工程名稱:天榮站

開料長度:5500, 總長料支數:10, 總開料支數:27

鋁材開料清單 AT03

鋸片厚度(mm):5, 料頭尾總切除(mm):100, 浪費率(%):15.78

窗號	編號(用料狀況)	實用長度(長料開數)	需要支數	開料支數	長料支數	餘料支數	編號(剩餘長度)
AT03-SU01-03	1-3	2174.0	5	5	3	0	1-2@(1042)x2 3@(3221)x1
AT03-SU01-06	(餘料)3	1944.0	1	1	0	1	3@(1272)x1
AT03-SU01-01	4-5	1844.0	4	4	2	0	4-5@(1702)x2
AT03-SU01-02	(餘料)4-5	1561.5	10	2	0	2	4-5@(135.5)x2
AT03-SU01-02, AT03-	6-8	1561.5		8	3	0	6-7@(700.5)x2
AT03-SU01-04	(餘料)8	1381.5	5	1	0	1	8@(880.5)x1
AT03-SU01-04	9-10	1381.5		4	2	0	9@(1240.5)x1
AT03-SU01-07	(餘料)10	1294.0	1	1	0	1	10@(2714.5)x1
AT03-SU01-08	(餘料)3	1181.5	1	1	0	1	3@(85.5)x1

工程號碼:J856, 工程名稱:天榮站

開料長度:5500, 總長料支數:14, 總開料支數:60

鋁材開料清單 AT02

鋸片厚度(mm):5, 料頭尾總切除(mm):100, 浪費率(%):8.57

窗號	編號(用料狀況)	實用長度(長料開數)	需要支數	開料支數	長料支數	餘料支數	編號(剩餘長度)
AT02-SU02-03	(餘料)3	2174.0	5	1	0	1	3@(76)x1
AT02-SU02-03	4-5	2174.0		4	2	0	4-5@(1042)x2
AT02-SU02-06	6	1944.0	1	1	1	0	6@(3451)x1
AT02-SU02-01	(餘料)6	1844.0	4	1	0	1	6@(1602)x1
AT02-SU02-01	7-8	1844.0		3	2	0	7@(1702)x1
AT02-SU02-02, AT02-SU02-05	(餘料)6-9	1561.5	10	6	0	4	6@(35.5)x1 7@(135.5)x1 8@(418)x1 9@(700.5)x1
AT02-SU02-02, AT02-SU02-04	9-10	1561.5		4	2	0	9@(3833.5)x1
AT02-SU02-07	(餘料)12	1294.0	1	1	0	1	12@(1328)x1
AT02-SU02-08	(餘料)11	1181.5	1	1	0	1	11@(54)x1
AT02-SU01-03	(餘料)4-5	894.0	2	2	0	2	4-5@(143)x2
AT02-SU01-04	(餘料)12	874.0	1	1	0	1	12@(449)x1
AT02-SU01-04	13	874.0		1	1	0	13@(4521)x1
AT02-SU01-02	(餘料)13	859.0		5	0	1	13@(201)x1
AT02-SU01-02	14	859.0		3	1	0	14@(2808)x1
AT02-SU01-01	1-3	624.0		21	3	0	1-2@(368)x2 3@(2255)x1

鋁材開料清單 AT01

窗號	編號(用料狀況)	實用長度(長料開數)	需要支數	開料支數	長料支數	餘料支數	編號(剩餘長度)
AT01-SU01-05	1-3	2185.0	5	5	3	0	1-2@(1020)x2 3@(3210)x1
AT01-SU01-08	(餘料)3	1955.0	1	1	0	1	3@(1250)x1
AT01-SU01-02	4-5	1855.0	4	4	2	0	4-5@(1680)x2
AT01-SU01-03	(餘料)4-5	1572.5	10	2	0	2	4-5@(102.5)x2
AT01-SU01-03, AT01-	6-8	1572.5		8	3	0	6-7@(667.5)x2
AT01-SU02-02	(餘料)8	1428.0		1	0	1	8@(812)x1
AT01-SU01-06	9-10	1392.5		4	2	0	9@(1207.5)x1
AT01-SU01-09	(餘料)10	1305.0		1	0	1	10@(2692.5)x1
AT01-SU01-11	(餘料)3	1192.5		1	0	1	3@(52.5)x1
AT01-SU02-04, AT01-	(餘料)1-2	940.5		2	0	2	1-2@(74.5)x2
AT01-SU03-04	(餘料)9	920.5		1	0	1	9@(282)x1
AT01-SU02-03	(餘料)10	905.5		2	0	1	10@(871.5)x1
AT01-SU03-02	11	905.5		2	1	0	11@(3579)x1
AT01-SU01-10	(餘料)11	885.0		1	0	1	11@(2689)x1
AT01-SU01-04	(餘料)11	870.0		3	0	1	11@(64)x1
AT01-SU01-04	12	870.0		1	1	0	12@(4525)x1
AT01-SU02-01, AT01-	(餘料)8, 10, 12, 12	670.5		8	0	4	8@(136.5)x1
AT01-SU03-01	13	670.5		2	1	0	13@(4049)x1
AT01-SU01-01	(餘料)6-7, 13	635.0		8	0	3	6-7@(27.5)x2
AT01-SU01-01	14	635.0		3	1	0	14@(3480)x1

鋁材開料清單 AM06

窗號	編號(用料狀況)	實用長度(長料開數)	需要 支數	開料 支數	長料 支數	餘料 支數	編號(剩餘長度)
AM06-SU01	1	2657.0	1	1	1	0	1@(438)x1

工程號碼:J856, 工程名稱:天榮站

開料長度:3000, 總長料支數:26, 總開料支數:26

鋸片厚度(mm):5, 料頭尾總切除(mm):100, 浪費率(%):7.93

鋁材開料清單 AM02

窗號	編號(用料狀況)	實用長度(長料開數)	需要 支數	開料 支數	長料 支數	餘料 支數	編號(剩餘長度)
AM02-SU01, AM02-SU02	1-26	2657.0	26	26	26	0	1-26@(238)x26

工程號碼:J856, 工程名稱:天榮站

開料長度:3000, 總長料支數:27, 總開料支數:27

鋸片厚度(mm):5, 料頭尾總切除(mm):100, 浪費率(%):7.93

鋁材開料清單 AM01

窗號	編號(用料狀況)	實用長度(長料開數)	需要 支數	開料 支數	長料 支數	餘料 支數	編號(剩餘長度)
AM01-SU01, AM01-SU02	1-27	2657.0	27	27	27	0	1-27@(238)x27

工程號碼:J856, 工程名稱:天榮站

開料長度:6500, 總長料支數:12, 總開料支數:36

鋸片厚度(mm):5, 料頭尾總切除(mm):100, 浪費率(%):8.23

鋁材開料清單 AJ04

窗號	編號(用料狀況)	實用長度(長料開數)	需要支數	開料支數	長料支數	餘料支數	編號(剩餘長度)
AJ04-P01, AJ04-P02	1-12	1950.0	36	36	12	0	1-12@(535)x12

鋁材開料清單 AJ03

窗號	編號(用料狀況)	實用長度(長料開數)	需要支數	開料支數	長料支數	餘料支數	編號(剩餘長度)
AJ03-SU01-05	1-3	2080.0	5	5	3	0	1-2@(1230)x2 3@(3315)x1
AJ03-SU02	(餘料)3	1950.0		1	0	1	3@(1360)x1
AJ03-SU02, AJ03-SU03	4-12	1950.0		17	9	0	4-11@(1490)x8 12@(3445)x1
AJ03-SU01-07	(餘料)12	1850.0		1	0	1	12@(1590)x1
AJ03-SU01-02	13-14	1750.0		4	2	0	13@(135)x1
AJ03-SU01-03	(餘料)4-12, 14	1467.5		10	0	10	4-11@(17.5)x8
AJ03-SU01-06	(餘料)3, 14	1287.5		2	0	2	3@(67.5)x1 14@(880)x1
AJ03-SU01-06	15	1287.5		3	1	0	15@(1522.5)x1
AJ03-SU01-09	(餘料)1	1200.0		1	0	1	1@(25)x1
AJ03-SU01-11	(餘料)2	1087.5		1	0	1	2@(137.5)x1
AJ03-SU01-08	(餘料)14-15	800.0		2	0	2	14@(75)x1 15@(717.5)x1
AJ03-SU01-10	16	780.0		2	1	0	16@(3830)x1
AJ03-SU01-04	(餘料)16	765.0		4	0	1	16@(750)x1
AJ03-SU01-04	17	765.0		4	1	0	17@(2320)x1
AJ03-SU01-01	(餘料)15-17	530.0		6	0	3	15@(182.5)x1
AJ03-SU01-01	18-19	530.0		15	2	0	18@(50)x1 19@(2725)x1

工程號碼:J856, 工程名稱:天榮站

開料長度:5000, 總長料支數:22, 總開料支數:132

鋁材開料清單 AD06

鋸片厚度(mm):5, 料頭尾總切除(mm):100, 浪費率(%):10.88

窗號	編號(用料狀況)	實用長度(長料開數)	需要支數	開料支數	長料支數	餘料支數	編號(剩餘長度)
AD06-P02	(餘料)7	862.0	66	2	0	1	7@(565)x1
AD06-P01, AD06-P02	1-14	862.0		64	14	0	1-6@(565)x6 7@(2299)x1
AD06-T07, AD06-T08	(餘料)14, 18	580.0	66	11	0	2	14@(523)x1 18@(220)x1
AD06-T07, AD06-T08	15-22	580.0		55	8	0	15-17@(220)x3 18@(3145)x1 19-21@(220)x3 22@(2560)x1

工程號碼:J856, 工程名稱:天榮站

開料長度:5500, 總長料支數:13, 總開料支數:60

鋁材開料清單 X86375

鋸片厚度(mm):5, 料頭尾總切除(mm):100, 浪費率(%):8.9

窗號	編號(用料狀況)	實用長度(長料開數)	需要支數	開料支數	長料支數	餘料支數	編號(剩餘長度)
X86375-SU01-05	1-3	2088.0	5	5	3	0	1-2@(1214)x2 3@(3307)x1
X86375-SU01-07	(餘料)3	1858.0	1	1	0	1	3@(1444)x1
X86375-SU01-02	4-5	1758.0	4	4	2	0	4@(111)x1 5@(3637)x1
X86375-SU01-03	(餘料)5	1475.5	10	2	0	1	5@(676)x1
X86375-SU01-03	6-8	1475.5		8	3	0	6-7@(958.5)x2
X86375-SU01-06	(餘料)3, 8	1295.5	5	2	0	2	3@(143.5)x1 8@(1138.5)x1
X86375-SU01-06	9	1295.5		3	1	0	9@(1498.5)x1
X86375-SU01-09	(餘料)1	1208.0	1	1	0	1	1@(1)x1
X86375-SU01-11	(餘料)2	1095.5	1	1	0	1	2@(113.5)x1
X86375-SU01-08	(餘料)6-7	808.0	2	2	0	2	6-7@(145.5)x2
X86375-SU01-10	(餘料)8-9	788.0	2	2	0	2	8@(345.5)x1 9@(705.5)x1
X86375-SU01-04	10-11	773.0		8	2	0	10@(732)x1
X86375-SU01-01	(餘料)5, 9-11	538.0		10	0	4	5@(133)x1 9@(162.5)x1
X86375-SU01-01	12-13	538.0		11	2	0	12@(513)x1 13@(4314)x1

鋁材開料清單 X86374

窗號	編號(用料狀況)	實用長度(長料開數)	需要支數	開料支數	長料支數	餘料支數	編號(剩餘長度)
X86374-SU01-05	1-3	2088.0	5	5	3	0	1-2@(1214)x2 3@(3307)x1
X86374-SU01-07	(餘料)3	1858.0	1	1	0	1	3@(1444)x1
X86374-SU01-02	4-5	1758.0	4	4	2	0	4@(111)x1 5@(3637)x1
X86374-SU01-03	(餘料)5	1475.5	10	2	0	1	5@(676)x1
X86374-SU01-03	6-8	1475.5		8	3	0	6-7@(958.5)x2
X86374-SU01-06	(餘料)3, 8	1295.5	5	2	0	2	3@(143.5)x1 8@(1138.5)x1
X86374-SU01-06	9	1295.5		3	1	0	9@(1498.5)x1
X86374-SU01-09	(餘料)1	1208.0	1	1	0	1	1@(1)x1
X86374-SU01-11	(餘料)2	1095.5	1	1	0	1	2@(113.5)x1
X86374-SU01-08	(餘料)6-7	808.0	2	2	0	2	6-7@(145.5)x2
X86374-SU01-10	(餘料)8-9	788.0	2	2	0	2	8@(345.5)x1 9@(705.5)x1
X86374-SU01-04	10-11	773.0		8	2	0	10@(732)x1
X86374-SU01-01	(餘料)5, 9-11	538.0		10	0	4	5@(133)x1 9@(162.5)x1
X86374-SU01-01	12-13	538.0		11	2	0	12@(513)x1 13@(4314)x1

工程號碼:J856, 工程名稱:天榮站

開料長度:6000, 總長料支數:12, 總開料支數:120

鋸片厚度(mm):5, 料頭尾總切除(mm):100, 浪費率(%):0.75

鋁材開料清單 X86371

窗號	編號(用料狀況)	實用長度(長料開數)	需要 支數	開料 支數	長料 支數	餘料 支數	編號(剩餘長度)
X86371-T03, X86371-T04	1-12	580.5	120	120	12	0	1-12@(45)x12

鋁材開料清單 X86412

窗號	編號(用料狀況)	實用長度(長料開數)	需要支數	開料支數	長料支數	餘料支數	編號(剩餘長度)
X86412-SK01-05, X86412-SU01-05	1-10	2180.0	20	20	10	0	1-10@(1030)x10
X86412-SK01-07, X86412-SU01-07	11-12	1950.0	4	4	2	0	11-12@(1490)x2
X86412-SK01-02, X86412-SU01-02	13-20	1850.0	16	16	8	0	13-20@(1690)x8
X86412-SK01-03	(餘料)13-20	1567.5	40	8	0	8	13-20@(117.5)x8
X86412-SK01-03, X86412-SU01-03	21-31	1567.5		32	11	0	21-30@(682.5)x10 31@(2255)x1
X86412-SK01-06, X86412-SU01-06	(餘料)11-12, 31, 34	1387.5	20	5	0	4	11-12@(97.5)x2 31@(862.5)x1 34@(1222.5)x1
X86412-SK01-06, X86412-SU01-06	32-37	1387.5		15	6	0	32-33@(1222.5)x2 34@(4007.5)x1
X86412-SK01-09	(餘料)37	1300.0		4	2	0	1
X86412-SU01-09	38	1300.0		2	1	0	38@(2790)x1
X86412-SK01-11, X86412-SU01-11	(餘料)32-35	1187.5	4	4	0	4	32-35@(30)x4
X86412-E01-03, X86412-E02-03, X86412-SK01-08, X86412-SU01-08	(餘料)1-10, 36, 38	900.0	12	12	0	12	1-10@(125)x10 36@(317.5)x1 38@(1885)x1
X86412-E01-04, X86412-SK01-10	(餘料)38-39	880.0	12	6	0	2	38@(115)x1 39@(90)x1
X86412-E02-04, X86412-SU01-10	39-40	880.0		6	2	0	39@(3630)x1 40@(1860)x1
X86412-E01-02, X86412-SK01-04	(餘料)40, 43	865.0	48	6	0	2	40@(120)x1 43@(180)x1
X86412-E01-02, X86412-E02-02, X86412-SK01-04,	41-48	865.0		42	8	0	41-42@(180)x2 43@(3660)x1
X86412-E01-01, X86412-E02-01, X86412-SK01-01, X86412-SU01-01	(餘料)21-31, 48-49, 52, 57	630.0	126	21	0	15	21-30@(47.5)x10 31@(227.5)x1 48@(15)x1 49@(320)x1 52@(320)x1 57@(320)x1
X86412-E01-01, X86412-E02-01, X86412-SK01-01, X86412-SU01-01	49-62	630.0		105	14	0	49@(955)x1 50-51@(320)x2 52@(2860)x1 53-56@(320)x4 57@(1590)x1 58-62@(320)x5

工程號碼:J856, 工程名稱:天榮站

開料長度:6500, 總長料支數:40, 總開料支數:240

鋸片厚度(mm):5, 料頭尾總切除(mm):100, 浪費率(%):6

鋁材開料清單 AC01

窗號	編號(用料狀況)	實用長度(長料開數)	需要支數	開料支數	長料支數	餘料支數	編號(剩餘長度)
AC01-P02-02, AC01-P02R-02	1-18	2037.0	54	54	18	0	1-18@(274)x18
AC01-P02R-01	(餘料)23	872.0		2	0	1	23@(261)x1
AC01-P02-01, AC01-P02R-01	19-28	872.0		64	10	0	19-22@(261)x4 23@(2015)x1
AC01-T01-02, AC01-T01R-02	(餘料)28, 34	597.0		12	0	2	28@(157)x1 34@(380)x1
AC01-T01-02, AC01-T01R-02	29-40	597.0		108	12	0	29-33@(380)x5 34@(3992)x1 35-39@(380)x5 40@(3992)x1

加工明细表

工程名称		J-856(天榮站)SU				施工分區(批次) :SU层			第一批
采购原因		正常采购	工序号	XXXXX		材料发送地:		工厂	2023/6/30
序号	型材模号	物料描述	图号	部件编号	长度 (mm)	数量	单位	颜色	备注
1	AC01	铝料加工图	AC01-P02-01	AC01-P02-01	872	33	支		
2	AC01	铝料加工图	AC01-P02R-01	AC01-P02R-01	872	33	支		
3	AC01	铝料加工图	AC01-P02-02	AC01-P02-02	2037	27	支		
4	AC01	铝料加工图	AC01-P02R-02	AC01-P02R-02	2037	27	支		
5	AC01	铝料加工图	AC01-T01-02	AC01-T01-02	597	60	支		
6	AC01	铝料加工图	AC01-T01R-02	AC01-T01R-02	597	60	支		
7	AD06	铝料加工图	AD06-P01	AD06-P01	862	33	支		
8	AD06	铝料加工图	AD06-P02	AD06-P02	862	33	支		
9	AD06	铝料加工图	AD06-T07	AD06-T07	580	33	支		
10	AD06	铝料加工图	AD06-T08	AD06-T08	580	33	支		
11	AJ03	铝料加工图	AJ03-SU01-01	AJ03-SU01-01	530	21	支		
12	AJ03	铝料加工图	AJ03-SU01-02	AJ03-SU01-02	1750	4	支		
13	AJ03	铝料加工图	AJ03-SU01-03	AJ03-SU01-03	1467.5	10	支		
14	AJ03	铝料加工图	AJ03-SU01-04	AJ03-SU01-04	765	8	支		
15	AJ03	铝料加工图	AJ03-SU01-05	AJ03-SU01-05	2080	5	支		
16	AJ03	铝料加工图	AJ03-SU01-06	AJ03-SU01-06	1287.5	5	支		
17	AJ03	铝料加工图	AJ03-SU01-07	AJ03-SU01-07	1850	1	支		
18	AJ03	铝料加工图	AJ03-SU01-08	AJ03-SU01-08	800	2	支		
19	AJ03	铝料加工图	AJ03-SU01-09	AJ03-SU01-09	1200	1	支		
20	AJ03	铝料加工图	AJ03-SU01-10	AJ03-SU01-10	780	2	支		
21	AJ03	铝料加工图	AJ03-SU01-11	AJ03-SU01-11	1087.5	1	支		
22	AJ03	铝料加工图	AJ03-SU02	AJ03-SU02	1950	9	支		
23	AJ03	铝料加工图	AJ03-SU03	AJ03-SU03	1950	9	支		
24	AJ04	铝料加工图	AJ04-P01	AJ04-P01	1950	18	支		
25	AJ04	铝料加工图	AJ04-P02	AJ04-P02	1950	18	支		
26	AM01	铝料加工图	AM01-SU01	AM01-SU01	2657	10	支		
27	AM01	铝料加工图	AM01-SU02	AM01-SU02	2657	17	支		
28	AM02	铝料加工图	AM02-SU01	AM02-SU01	2657	16	支		
29	AM02	铝料加工图	AM02-SU02	AM02-SU02	2657	10	支		
30	AM06	铝料加工图	AM06-SU01	AM06-SU01	2657	1	支		
31	AT01	铝料加工图	AT01-SU01-02	AT01-SU01-02	1855	4	支		
32	AT01	铝料加工图	AT01-SU01-01	AT01-SU01-01	635	11	支		
33	AT01	铝料加工图	AT01-SU01-03	AT01-SU01-03	1572.5	5	支		
34	AT01	铝料加工图	AT01-SU01-04	AT01-SU01-04	870	4	支		
35	AT01	铝料加工图	AT01-SU01-05	AT01-SU01-05	2185	5	支		
36	AT01	铝料加工图	AT01-SU01-06	AT01-SU01-06	1392.5	4	支		
37	AT01	铝料加工图	AT01-SU01-07	AT01-SU01-07	1572.5	5	支		
38	AT01	铝料加工图	AT01-SU01-08	AT01-SU01-08	1955	1	支		
39	AT01	铝料加工图	AT01-SU01-09	AT01-SU01-09	1305	1	支		
40	AT01	铝料加工图	AT01-SU01-10	AT01-SU01-10	885	1	支		
41	AT01	铝料加工图	AT01-SU01-11	AT01-SU01-11	1192.5	1	支		
42	AT01	铝料加工图	AT01-SU02-01	AT01-SU02-01	670.5	5	支		
43	AT01	铝料加工图	AT01-SU02-02	AT01-SU02-02	1428	1	支		
44	AT01	铝料加工图	AT01-SU02-03	AT01-SU02-03	905.5	2	支		
45	AT01	铝料加工图	AT01-SU02-04	AT01-SU02-04	940.5	1	支		
46	AT01	铝料加工图	AT01-SU03-01	AT01-SU03-01	670.5	5	支		
47	AT01	铝料加工图	AT01-SU03-02	AT01-SU03-02	905.5	2	支		
48	AT01	铝料加工图	AT01-SU03-03	AT01-SU03-03	940.5	1	支		
49	AT01	铝料加工图	AT01-SU03-04	AT01-SU03-04	920.5	1	支		
50	AT02	铝料加工图	AT02-SU01-01	AT02-SU01-01	624	21	支		
51	AT02	铝料加工图	AT02-SU01-02	AT02-SU01-02	859	8	支		
52	AT02	铝料加工图	AT02-SU01-03	AT02-SU01-03	894	2	支		
53	AT02	铝料加工图	AT02-SU01-04	AT02-SU01-04	874	2	支		

54	AT02	铝料加工图	AT02-SU02-01	AT02-SU02-01	1844	4	支	
55	AT02	铝料加工图	AT02-SU02-02	AT02-SU02-02	1561.5	5	支	
56	AT02	铝料加工图	AT02-SU02-03	AT02-SU02-03	2174	5	支	
57	AT02	铝料加工图	AT02-SU02-04	AT02-SU02-04	1381.5	5	支	
58	AT02	铝料加工图	AT02-SU02-05	AT02-SU02-05	1561.5	5	支	
59	AT02	铝料加工图	AT02-SU02-06	AT02-SU02-06	1944	1	支	
60	AT02	铝料加工图	AT02-SU02-07	AT02-SU02-07	1294	1	支	
61	AT02	铝料加工图	AT02-SU02-08	AT02-SU02-08	1181.5	1	支	
62	AT03	铝料加工图	AT03-SU01-01	AT03-SU01-01	1844	4	支	
63	AT03	铝料加工图	AT03-SU01-02	AT03-SU01-02	1561.5	5	支	
64	AT03	铝料加工图	AT03-SU01-03	AT03-SU01-03	2174	5	支	
65	AT03	铝料加工图	AT03-SU01-04	AT03-SU01-04	1381.5	5	支	
66	AT03	铝料加工图	AT03-SU01-05	AT03-SU01-05	1561.5	5	支	
67	AT03	铝料加工图	AT03-SU01-06	AT03-SU01-06	1944	1	支	
68	AT03	铝料加工图	AT03-SU01-07	AT03-SU01-07	1294	1	支	
69	AT03	铝料加工图	AT03-SU01-08	AT03-SU01-08	1181.5	1	支	
70	AT04	铝料加工图	AT04-SU01-01	AT04-SU01-01	630	7	支	
71	AT04	铝料加工图	AT04-SU02-001	AT04-SU02-001	630	5	支	
72	AT04	铝料加工图	AT04-SU02-002	AT04-SU02-002	682.5	8	支	
73	AT04	铝料加工图	AT04-SU02-003	AT04-SU02-003	582.5	2	支	
74	AT04	铝料加工图	AT04-SU02-004	AT04-SU02-004	682.5	2	支	
75	AT04	铝料加工图	AT04-SU03-01	AT04-SU03-01	630	9	支	
76	AT05	铝料加工图	AT05-SU01-01	AT05-SU01-01	630	7	支	
77	AT05	铝料加工图	AT05-SU02-01	AT05-SU02-01	630	5	支	
78	AT05	铝料加工图	AT05-SU02-02	AT05-SU02-02	865	8	支	
79	AT05	铝料加工图	AT05-SU02-03	AT05-SU02-03	900	2	支	
80	AT05	铝料加工图	AT05-SU02-04	AT05-SU02-04	880	2	支	
81	AT05	铝料加工图	AT05-SU03-01	AT05-SU03-01	630	9	支	
82	GS01	铝料加工图	GS01-K01	GS01-K01	300	51	支	
83	GS01	铝料加工图	GS01-K02	GS01-K02	150	18	支	
84	60X40X3铝角	铝料加工图	J60*38-001	J60*38-001	15	25	支	
85	60X40X3铝角	铝料加工图	J60*38-002	J60*38-002	15	24	支	
86	60X40X3铝角	铝料加工图	J60*38-003	J60*38-003	15	14	支	
87	MS01	铝料加工图	MS01-P01	MS01-P01	320	120	支	
88	X86364	铝料加工图	X86364-SU01	X86364-SU01	2657	7	支	
89	X86364	铝料加工图	X86364-SU02	X86364-SU02	2657	9	支	
90	X86364	铝料加工图	X86364-SU03	X86364-SU03	2657	6	支	
91	X86364	铝料加工图	X86364-SU04	X86364-SU04	2657	2	支	
92	X86365	铝料加工图	X86365-SU01	X86365-SU01	2657	5	支	
93	X86365	铝料加工图	X86365-SU02	X86365-SU02	2657	3	支	
94	X86365	铝料加工图	X86365-SU03	X86365-SU03	2657	8	支	
95	X86365	铝料加工图	X86365-SU04	X86365-SU04	2657	9	支	
96	X86367	铝料加工图	X86367-SU01	X86367-SU01	2657	2	支	
97	X86367	铝料加工图	X86367-SU02	X86367-SU02	2657	6	支	
98	X86367	铝料加工图	X86367-SU03	X86367-SU03	2657	6	支	
99	X86367	铝料加工图	X86367-SU04	X86367-SU04	2657	3	支	
100	X86371	铝料加工图	X86371-T03	X86371-T03	580.5	60	支	
101	X86371	铝料加工图	X86371-T04	X86371-T04	580.5	60	支	
102	X86372	铝料加工图	X86372-P01	X86372-P01	320	60	支	
103	X86372	铝料加工图	X86372-P02	X86372-P02	320	60	支	
104	X86374	铝料加工图	X86374-SU01-01	X86374-SU01-01	538	21	支	
105	X86374	铝料加工图	X86374-SU01-02	X86374-SU01-02	1758	4	支	
106	X86374	铝料加工图	X86374-SU01-03	X86374-SU01-03	1475.5	10	支	
107	X86374	铝料加工图	X86374-SU01-04	X86374-SU01-04	773	8	支	
108	X86374	铝料加工图	X86374-SU01-05	X86374-SU01-05	2088	5	支	
109	X86374	铝料加工图	X86374-SU01-06	X86374-SU01-06	1295.5	5	支	
110	X86374	铝料加工图	X86374-SU01-07	X86374-SU01-07	1858	1	支	
111	X86374	铝料加工图	X86374-SU01-08	X86374-SU01-08	808	2	支	
112	X86374	铝料加工图	X86374-SU01-09	X86374-SU01-09	1208	1	支	

113	X86374	铝料加工图	X86374-SU01-10	X86374-SU01-10	788	2	支	
114	X86374	铝料加工图	X86374-SU01-11	X86374-SU01-11	1095.5	1	支	
115	X86375	铝料加工图	X86375-SU01-01	X86375-SU01-01	538	21	支	
116	X86375	铝料加工图	X86375-SU01-02	X86375-SU01-02	1758	4	支	
117	X86375	铝料加工图	X86375-SU01-03	X86375-SU01-03	1475.5	10	支	
118	X86375	铝料加工图	X86375-SU01-04	X86375-SU01-04	773	8	支	
119	X86375	铝料加工图	X86375-SU01-05	X86375-SU01-05	2088	5	支	
120	X86375	铝料加工图	X86375-SU01-06	X86375-SU01-06	1295.5	5	支	
121	X86375	铝料加工图	X86375-SU01-07	X86375-SU01-07	1858	1	支	
122	X86375	铝料加工图	X86375-SU01-08	X86375-SU01-08	808	2	支	
123	X86375	铝料加工图	X86375-SU01-09	X86375-SU01-09	1208	1	支	
124	X86375	铝料加工图	X86375-SU01-10	X86375-SU01-10	788	2	支	
125	X86375	铝料加工图	X86375-SU01-11	X86375-SU01-11	1095.5	1	支	
126	X86412	铝料加工图	X86412-SK01-01	X86412-SK01-01	630	42	支	
127	X86412	铝料加工图	X86412-SK01-02	X86412-SK01-02	1850	8	支	
128	X86412	铝料加工图	X86412-SK01-03	X86412-SK01-03	1567.5	20	支	
129	X86412	铝料加工图	X86412-SK01-04	X86412-SK01-04	865	16	支	
130	X86412	铝料加工图	X86412-SK01-05	X86412-SK01-05	2180	10	支	
131	X86412	铝料加工图	X86412-SK01-06	X86412-SK01-06	1387.5	10	支	
132	X86412	铝料加工图	X86412-SK01-07	X86412-SK01-07	1950	2	支	
133	X86412	铝料加工图	X86412-SK01-08	X86412-SK01-08	900	4	支	
134	X86412	铝料加工图	X86412-SK01-09	X86412-SK01-09	1300	2	支	
135	X86412	铝料加工图	X86412-SK01-10	X86412-SK01-10	880	4	支	
136	X86412	铝料加工图	X86412-SK01-11	X86412-SK01-11	1187.5	2	支	
137	X86412	铝料加工图	X86412-SU01-01	X86412-SU01-01	630	42	支	
138	X86412	铝料加工图	X86412-SU01-02	X86412-SU01-02	1850	8	支	
139	X86412	铝料加工图	X86412-SU01-03	X86412-SU01-03	1567.5	20	支	
140	X86412	铝料加工图	X86412-SU01-04	X86412-SU01-04	865	16	支	
141	X86412	铝料加工图	X86412-SU01-05	X86412-SU01-05	2180	10	支	
142	X86412	铝料加工图	X86412-SU01-06	X86412-SU01-06	1387.5	10	支	
143	X86412	铝料加工图	X86412-SU01-07	X86412-SU01-07	1950	2	支	
144	X86412	铝料加工图	X86412-SU01-08	X86412-SU01-08	900	4	支	
145	X86412	铝料加工图	X86412-SU01-09	X86412-SU01-09	1300	2	支	
146	X86412	铝料加工图	X86412-SU01-10	X86412-SU01-10	880	4	支	
147	X86412	铝料加工图	X86412-SU01-11	X86412-SU01-11	1187.5	2	支	
148	X86412	铝料加工图	X86412-E01-01	X86412-E01-01	630	21	支	
149	X86412	铝料加工图	X86412-E01-02	X86412-E01-02	865	8	支	
150	X86412	铝料加工图	X86412-E01-03	X86412-E01-03	900	2	支	
151	X86412	铝料加工图	X86412-E01-04	X86412-E01-04	880	2	支	
152	X86412	铝料加工图	X86412-E02-01	X86412-E02-01	630	21	支	
153	X86412	铝料加工图	X86412-E02-02	X86412-E02-02	865	8	支	
154	X86412	铝料加工图	X86412-E02-03	X86412-E02-03	900	2	支	
155	X86412	铝料加工图	X86412-E02-04	X86412-E02-04	880	2	支	
156	AC02	铝料加工图	AC02-E01-1	AC02-E01-1	1137	33	支	
157	AC02	铝料加工图	AC02-E01R-1	AC02-E01R-1	1137	33	支	
158	JM1069	铝料加工图	JS01-Q01	JS01-Q01	35	66	支	
159	JM1069	铝料加工图	JS01-Q02	JS01-Q02	35	66	支	
160	WS01	铝料加工图	WS01-P01	WS01-P01	1155	16	支	
161	WS01	铝料加工图	WS01-P02	WS01-P02	1155	7	支	
162	WS01	铝料加工图	WS01-P03	WS01-P03	1155	9	支	
163	WS01	铝料加工图	WS01-P04	WS01-P04	1115	17	支	
164	WS01	铝料加工图	WS01-P05	WS01-P05	1115	17	支	
165	WS03	铝料加工图	WS03-P01	WS03-P01	630	7	支	
166	WS03	铝料加工图	WS03-P02	WS03-P02	630	7	支	
167	WS03	铝料加工图	WS03-P03	WS03-P03	630	9	支	
168	WS03	铝料加工图	WS03-P04	WS03-P04	630	9	支	
169	WS03	铝料加工图	WS03-P05	WS03-P05	630	5	支	
170	WS03	铝料加工图	WS03-P06	WS03-P06	630	5	支	
171	WS03	铝料加工图	WS03-P11	WS03-P11	865	8	支	

172	WS03	铝料加工图	WS03-P12	WS03-P12	865	8	支		
173	WS03	铝料加工图	WS03-P13	WS03-P13	900	2	支		
174	WS03	铝料加工图	WS03-P14	WS03-P14	900	2	支		
175	WS03	铝料加工图	WS03-P15	WS03-P15	880	2	支		
176	WS03	铝料加工图	WS03-P16	WS03-P16	880	2	支		
177	X86370	铝料加工图	X86370-K01	X86370-K01	55	82	支		
178	X86370	铝料加工图	X86370-P01	X86370-P01	604.5	16	支		
179	X86370	铝料加工图	X86370-P02	X86370-P02	289.5	16	支		
180	X86370	铝料加工图	X86370-P03	X86370-P03	560.5	34	支		
181	X86370	铝料加工图	X86370-P04-01	X86370-P04-01	233	10	支		
182	X86370	铝料加工图	X86370-P04-05	X86370-P04-05	350.5	16	支		
183	X86370	铝料加工图	X86370-P04-06	X86370-P04-06	368	4	支		
184	X86370	铝料加工图	X86370-P04-07	X86370-P04-07	368	4	支		
185	AS01	铝料加工图	AS01-001	AS01-001	150	40	支		
186		3MM铝板折	AX04-P03	AX04-P03	1950	9	支		
187		3MM铝板折	AX04-P04	AX04-P04	1950	9	支		

以下空白

说明：1:注意保护成品，严禁刻痕、划伤；

设计：校对：审核：

圖則登記表
DRAWING REGISTER

工程名稱 Project Title: 天榮站单元体组装		接收日期 Receiving Date (適用於客戶圖則)							
拆圖(SU层)/T1~T2-T3									
工程編號 Project No: J-856									

分發予 Distributed To		發出日期 Issued Date							
	年	23							
	月	06							
	日	30							

圖則編號 Drg. No.	圖則名稱 Drawing Title
CW-401	单元组装图
CW-402	单元组装图
CW-403	单元组装图
CW-404	单元组装图
CW-405	单元组装图
CW-406	单元组装图
CW-407	单元组装图
CW-408	单元组装图
CW-409	单元组装图
CW-410	单元组装图
CW-411	单元组装图
CW-412	单元组装图
CW-413	单元组装图
CW-414	单元组装图
CW-415	单元组装图
CW-416	单元组装图
CW-417	单元组装图
CW-418	单元组装图
CW-419	单元组装图
CW-420	单元组装图
CW-421	单元组装图
CW-422	单元组装图
CW-423	单元组装图
CW-424	单元组装图
CW-425	单元组装图
CE-001	窗玉组装图
CE-002	窗玉组装图
CE-003	窗玉组装图
CE-011	窗玉组装图
CE-012	窗玉组装图
CE-013	窗玉组装图
AC01-P01	铝料加工图

修訂編號 Revision No.							
-							
-							
-							
-							
-							
-							
-							
-							
-							
-							
-							
-							
-							
-							
-							
-							
-							
-							
-							
-							
-							
-							

AC01-T02R	铝料加工图	-							
X86412-P01	铝料加工图	-							
X86412-P02	铝料加工图	-							
X86372-P01	铝料加工图	-							
X86372-P02	铝料加工图	-							
GS01-K01	铝料加工图	-							
GS01-K02	铝料加工图	-							
AS01-001	铝料加工图	-							
J60*38*001	铝料加工图	-							
J60*38*002	铝料加工图	-							
J60*38*003	铝料加工图	-							
MS01-001	铝料加工图	-							
AJ03-SU01	铝料加工图	-							
AJ03-SU02	铝料加工图	-							
AJ03-SU03	铝料加工图	-							
AJ04-P01	铝料加工图	-							
AJ04-P02	铝料加工图	-							
AX04-P01	铝料加工图	-							
AX04-P02	铝料加工图	-							
AX04-P03	铝料加工图	-							
AX04-P04	铝料加工图	-							
WS01-P01	铝料加工图	-							
WS01-P02	铝料加工图	-							
WS01-P03	铝料加工图	-							
WS01-P04	铝料加工图	-							
WS01-P05	铝料加工图	-							
WS03-P01	铝料加工图	-							
WS03-P02	铝料加工图	-							
WS03-P03	铝料加工图	-							
WS03-P04	铝料加工图	-							
WS03-P05	铝料加工图	-							
WS03-P06	铝料加工图	-							
WS03-P11	铝料加工图	-							
WS03-P12	铝料加工图	-							
WS03-P13	铝料加工图	-							
WS03-P14	铝料加工图	-							
WS03-P15	铝料加工图	-							
WS03-P16	铝料加工图	-							
X86370-P01	铝料加工图	-							
X86370-P02	铝料加工图	-							
X86370-P03	铝料加工图	-							
X86370-P04	铝料加工图	-							
X86370-K1	铝料加工图	-							
X86412-E01	铝料加工图	-							
X86412-E02	铝料加工图	-							

AC02-E01	铝料加工图
AC02-E01R	铝料加工图
JS01-Q01	铝料加工图
JS01-Q02	铝料加工图

-									
-									
-									
-									

 美特鋁質有限公司 MIDI Aluminium Fabricator Ltd.		工程號 J856 地盤 天榮站	類別 制圖 李傳鵬 復核 練松文 批准 林仁安	物料號 M1 圖號 CW-401 數量 - 單件重量 - (KG)
修改 日期	採用工廠 材料顏色 -UCT542919XL-3	地盤 <input checked="" type="checkbox"/> 图纸名称 单元组装图 材料 -		

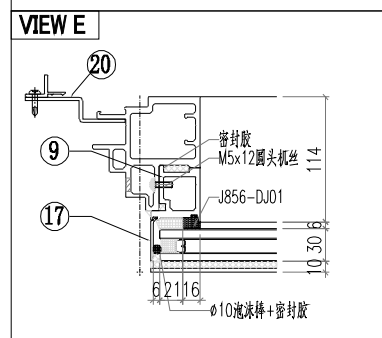
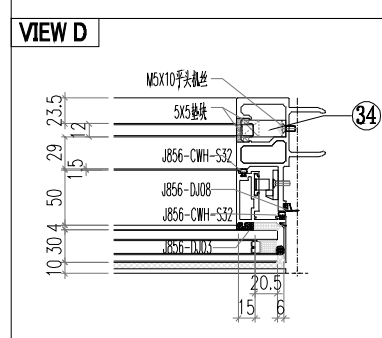
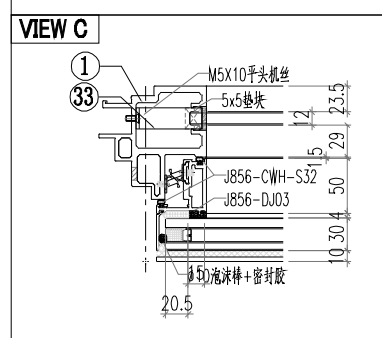
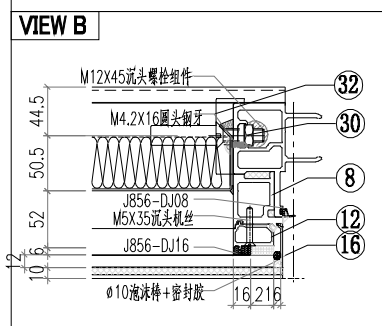
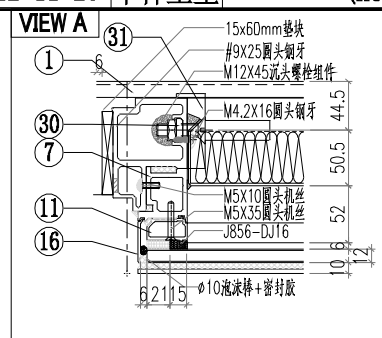
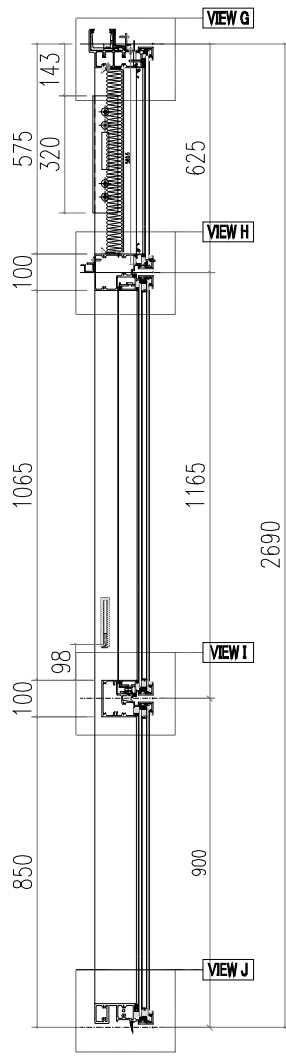
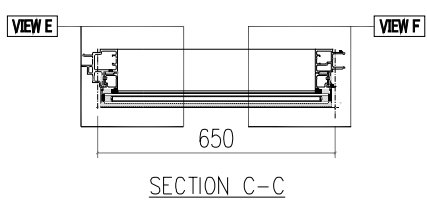
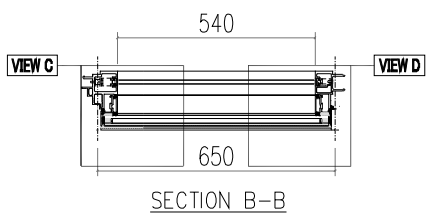
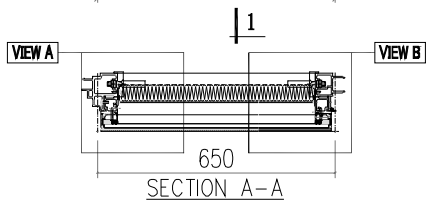
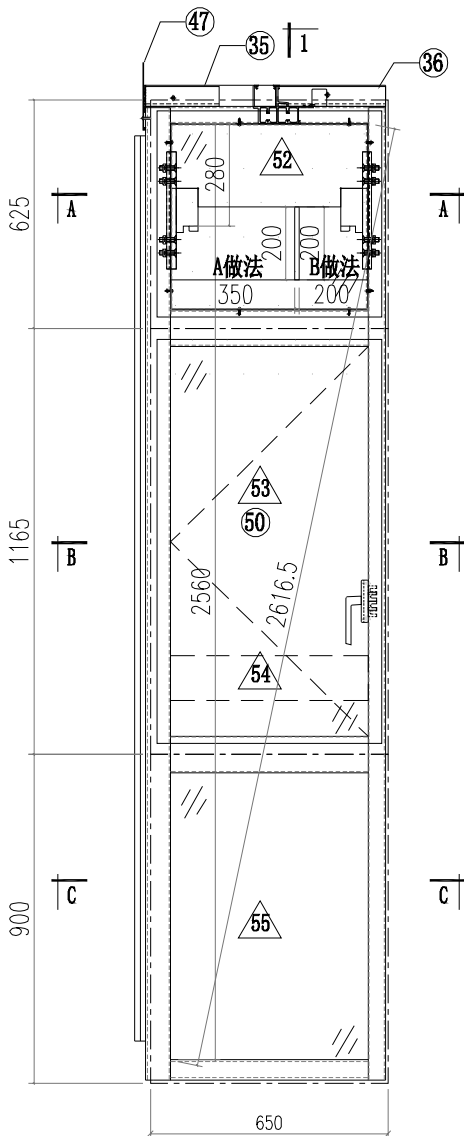

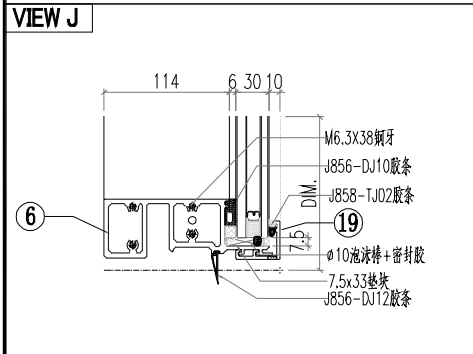
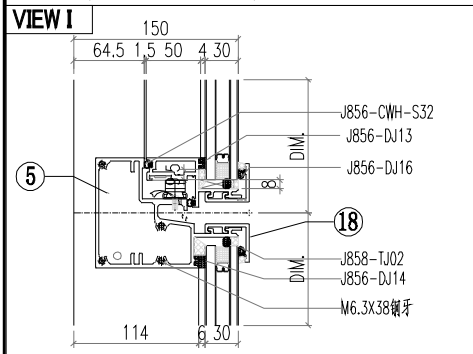
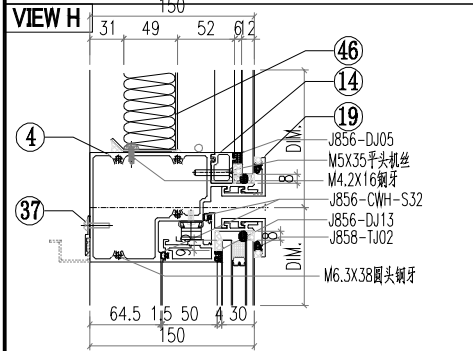
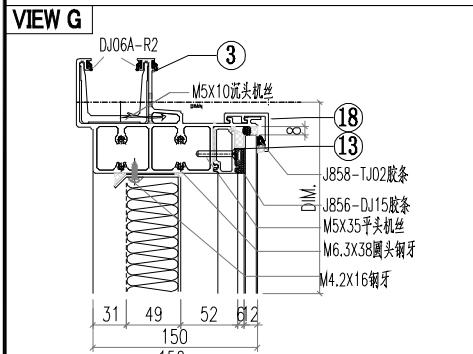
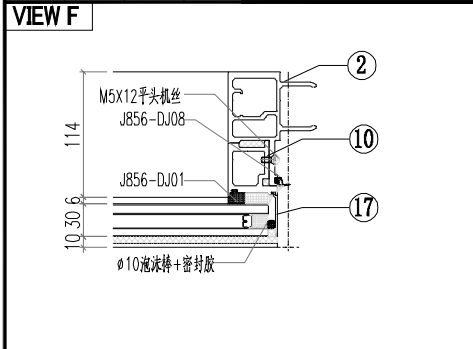

ALUM. EXTRUSION

ITEM	FAB. DWG NO.	LENGTH (mm)	QTY
1	X86367-SU01	2657	1
2	X86364-SU01	2657	1
3	AT01-SU02-001	670.5	1
4	AT04-SU01-001	630	1
5	AT05-SU01-001	630	1
6	AT02-SU01-001	624	1
7	AD06-T07	580	1
8	AD06-T08	580	1
9	AD06-P01	862	1
10	AD06-P02	862	1
11	X86371-T03	580.5	1
12	X86371-T04	580.5	1
13	X86374-SU01-01	538	1
14	X86375-SU01-01	538	1
15			
16	AC01-T01-02/AC01-T01R-2	597	2
17	AC01-P02-01/AC01-P02R-1	872	2
18	X86412-SU01-01	630	2
19	X86412-SK01-01	630	2
20	AX04-P04	1950	1
21			
22			
23			
24			
25			
26			
27			
28			
29			

OTHERS (ALUM. & G.M.S. PARTS)

ITEM	FAB. DWG NO.	LENGTH (mm)	QTY
30	MS01-P01	320	2
31	X86372-P01	320	1
32	X86372-P02	320	1
33	J60*38-003	15	1
34	J60*38-002	15	1
35	GS01-K02	150	1
36	GS01-K01	300	1
37	AJ03-SU01-1	530	1
38			
39			
40	CE-002		
41			
42			
43			
44			
45			
46	BP-DA01		1
47	538X508		1
48	LB-P02		1
49			
50			
51			
52	PT-GL04-A08 614X565		1
53	PT-GL01-B01 614X1105		1
54	PT-GL05-A01 570X122		1
55	PT-GL01-A01 614X840		1

 美特鋁質有限公司 MIDI Aluminium Fabricator Ltd.				工程號 J856	類別 制圖	物料號 M1	圖號 CW-402
修改 日期	採用工廠 地盤 <input checked="" type="checkbox"/>	地盤 <input checked="" type="checkbox"/>	圖紙名稱 單元組裝圖	復核 林仁安	2022-11-26 2022-11-27 2022-11-28	數量 -	單件重量 - (KG)

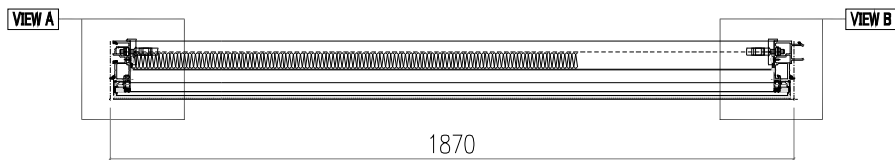
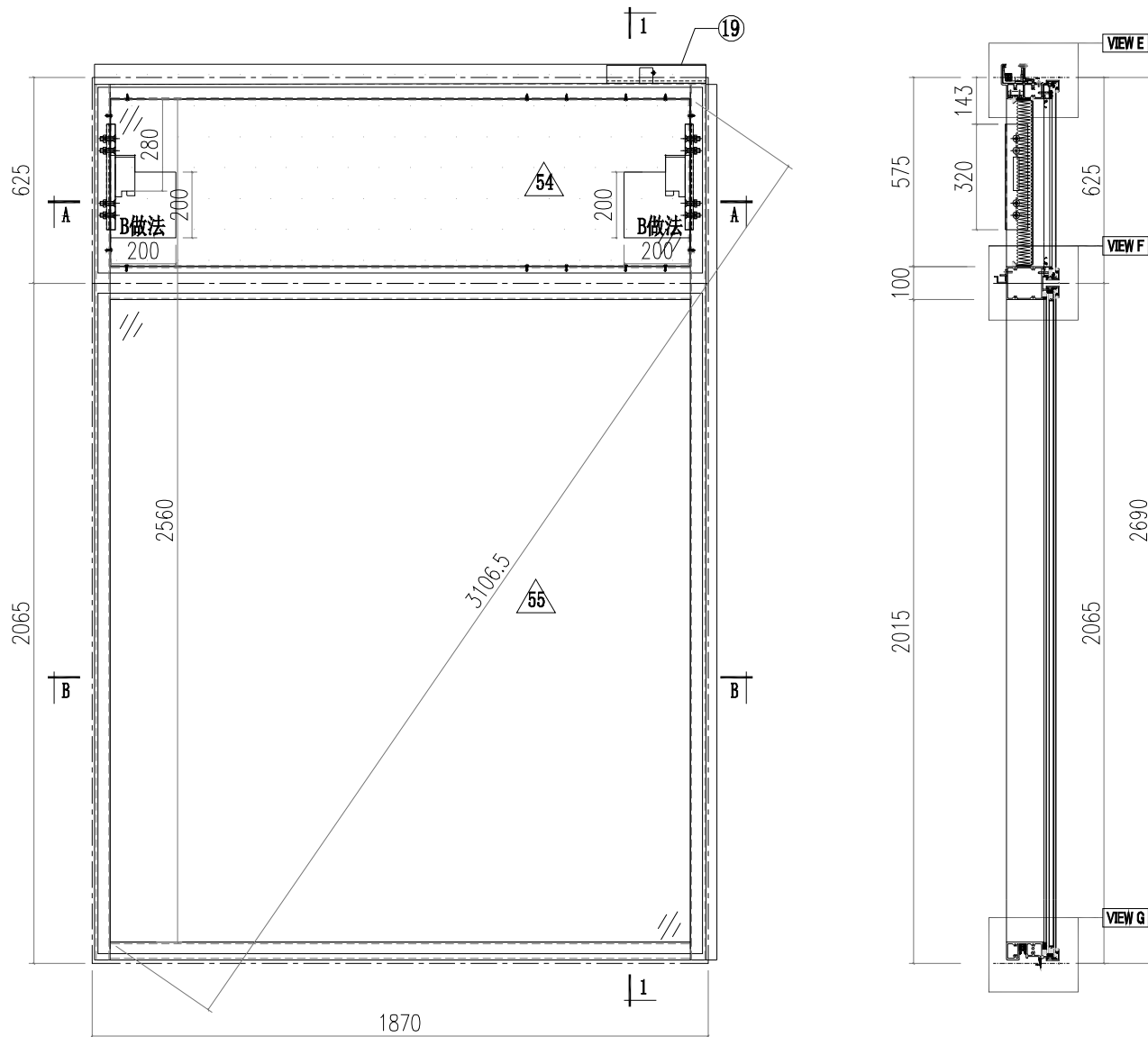

SECTION A-A
1760

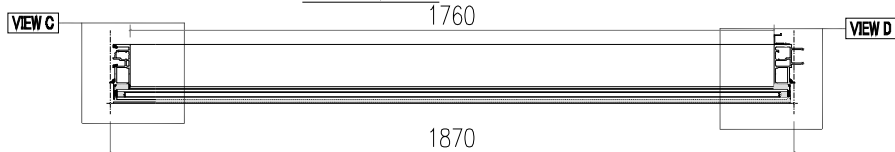

SECTION B-B

 美特鋁質有限公司 MIDI Aluminium Fabricator Ltd.			工程號 J856 地盤 天榮站	類別 制圖 李傳鵬 復核 練松文 批准 林仁安	物料號 M1 2022-11-26 2022-11-27 2022-11-28	圖號 CW-402 數量 - 單件重量 - (KG)
修改日期 採用工廠 地盤 <input checked="" type="checkbox"/>	圖紙名稱 單元組裝圖 材料 -	材料顏色 - UCT542919XL-3				

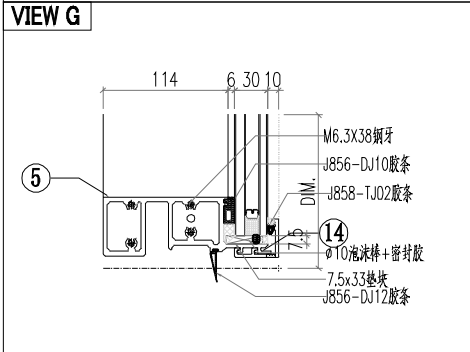
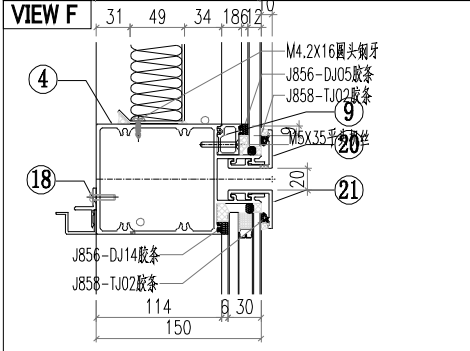
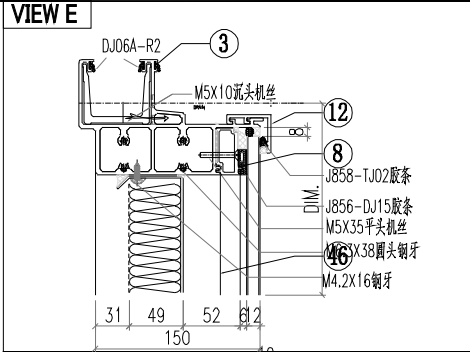
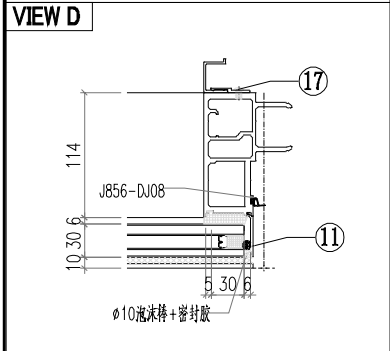
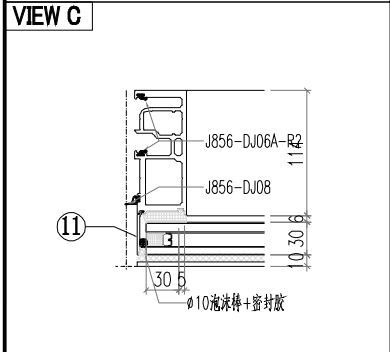
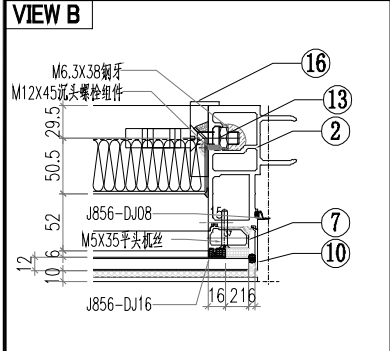
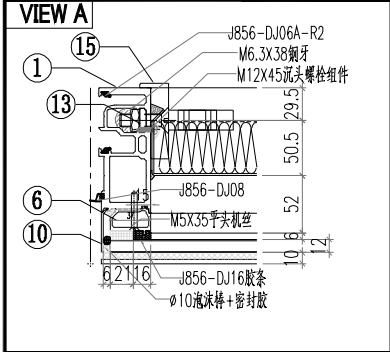

OTHERS (ALUM. & G.M.S. PARTS)

ITEM	FAB. DWG NO.	LENGTH (mm)	QTY
46	BP-DA02		1
	1758X508		
47			
48			
49			
50			
51			
52			
53			
54	PT-GL04-A08A		1
	1834X565		
55	PT-GL01-A08		1
	1834X2005		

ALUM. EXTRUSION

ITEM	FAB. DWG NO.	LENGTH (mm)	QTY
1	AM02-SU01	2657	1
2	AM01-SU01	2657	1
3	AT01-SU01-002	1855	1
4	AT03-SU01-001	1844	1
5	AT02-SU02-001	1844	1
6	X86371-T04	580.5	1
7	X86371-T03	580.5	1
8	X86374-SU01-02	1758	1
9	X86375-SU01-02	1758	1
10	AC01-T01-02/AC01-T01R-2	597	2
11	AC01-P02-02/AC01-P02R-2	2037	2
12	X86412-SU01-02	1850	2
13	MS01-P01	320	2
14	X86412-SK01-02	1850	2
15	X86372-P01	320	1
16	X86372-P02	320	1
17	AJ04-P01	1950	1
18	AJ03-SU01-02	1750	1
19	GS01-K01	300	1
20			
21			
22			
23			
24			
25			
26			
27			
28			
29			
30			
31			
32			
33			
34			
35			
36			
37			
38			
39			
40			
41			
42			
43			
44			
45			

 美特鋁質有限公司 MIDI Aluminium Fabricator Ltd.		工程號 J856 地盤 天榮站	類別 制圖 李傳鵬 復核 練松文 批准 林仁安	物料號 M1 圖號 CW-403 數量 - 單件重量 - (KG)
修改日期	採用工廠	地盤 <input checked="" type="checkbox"/>	图纸名称 单元组装图	日期 2022-11-26 2022-11-27 2022-11-28
	材料颜色 -UCT542919XL-3		材料 -	

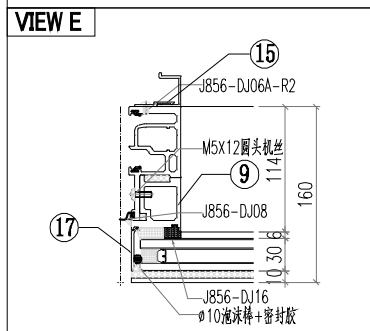
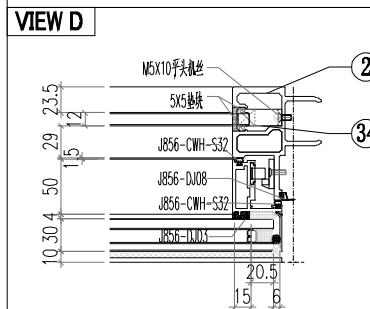
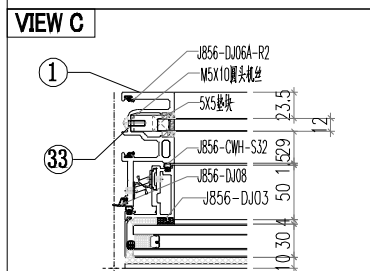
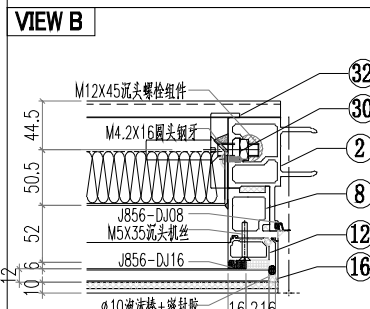
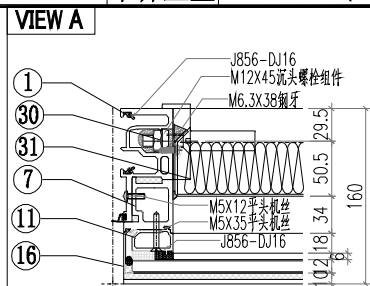
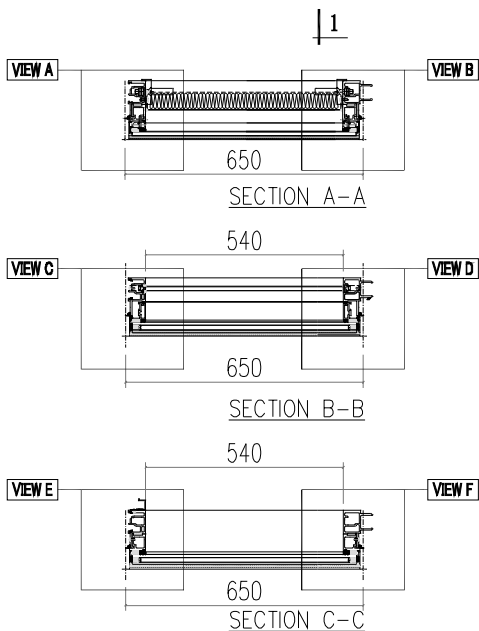
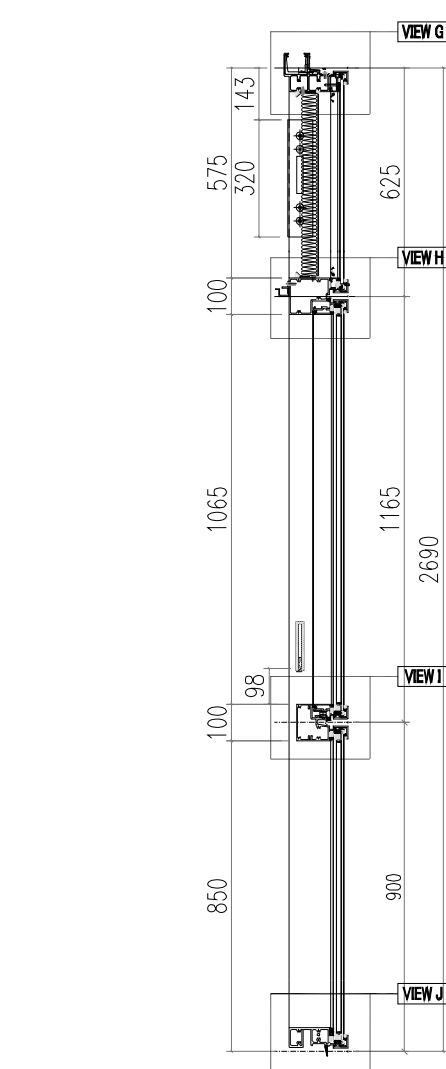
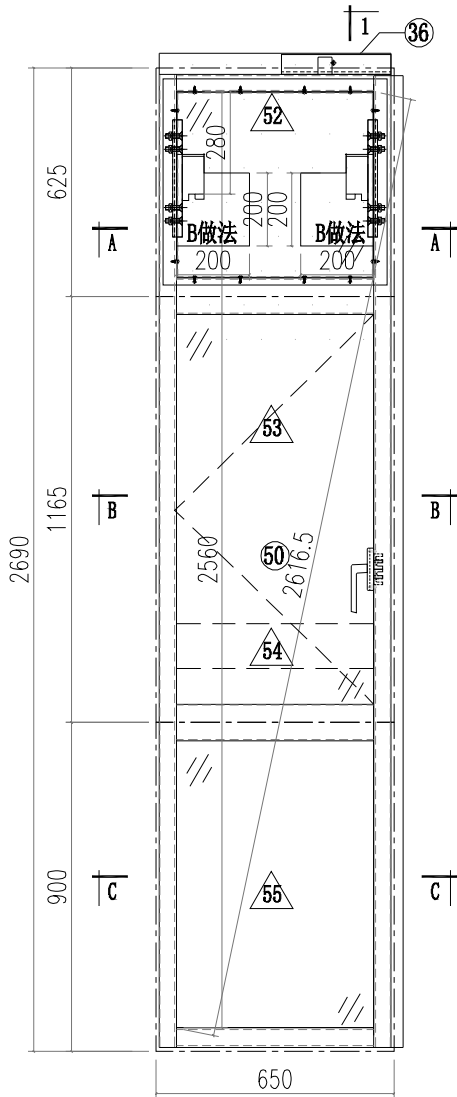

工程號	J856	類別		物料號	M1			
地盤	天榮站	制圖	李傳鵬	2022-11-26	圖號	CW-403		
修改		採用工廠	地盤	✓	日期			
日期		材料顏色	- UCT542919XL-3	材料	-	單件重量	(KG)	
日期		材料	-	批准	林仁安	2022-11-28	數量	-

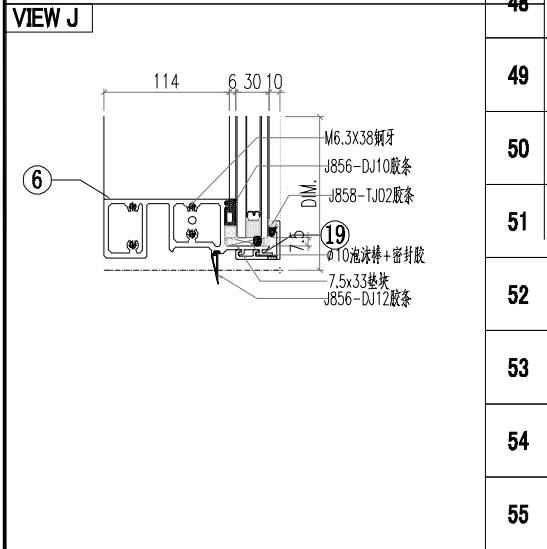
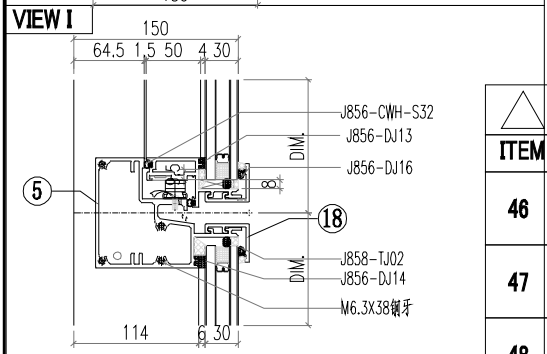
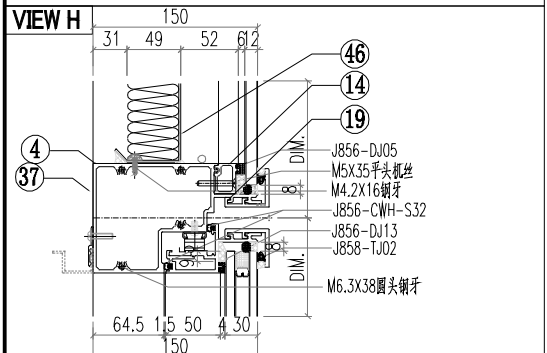
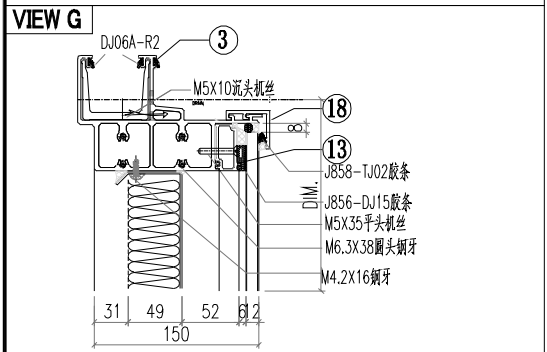
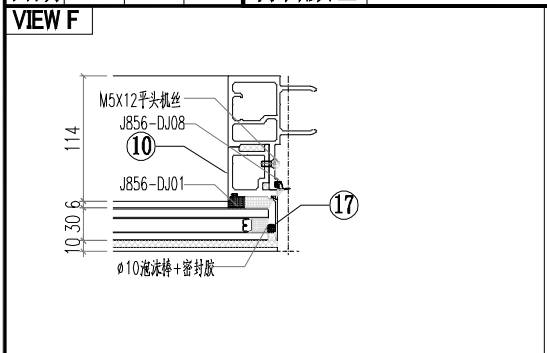

				ALUM. EXTRUSION			
ITEM	FAB. DWG NO.	LENGTH (mm)	QTY	ITEM	FAB. DWG NO.	LENGTH (mm)	QTY
1	X86365-SU01	2657	1	1	X86365-SU01	2657	1
2	X86364-SU01	2657	1	2	X86364-SU01	2657	1
3	AT01-SU01-001	635	1	3	AT01-SU01-001	635	1
4	AT04-SU01-001	630	1	4	AT04-SU01-001	630	1
5	AT05-SU01-001	630	1	5	AT05-SU01-001	630	1
6	AT02-SU01-001	624	1	6	AT02-SU01-001	624	1
7	AD06-T07	580	1	7	AD06-T07	580	1
8	AD06-T08	580	1	8	AD06-T08	580	1
9	AD06-P01	862	1	9	AD06-P01	862	1
10	AD06-P02	862	1	10	AD06-P02	862	1
11	X86371-T03	580.5	1	11	X86371-T03	580.5	1
12	X86371-T04	580.5	1	12	X86371-T04	580.5	1
13	X86374-SU01-01	538	1	13	X86374-SU01-01	538	1
14	X86375-SU01-01	538	1	14	X86375-SU01-01	538	1
15	AJ04-P02	1950	1	15	AJ04-P02	1950	1
16	AC01-T01-02/AC01-T01R-2	597	2	16	AC01-T01-02/AC01-T01R-2	597	2
17	AC01-P02-01/AC01-P02R-1	872	2	17	AC01-P02-01/AC01-P02R-1	872	2
18	X86412-SU01-01	630	2	18	X86412-SU01-01	630	2
19	X86412-SK01-01	630	2	19	X86412-SK01-01	630	2
20				20			
21				21			
22				22			
23				23			
24				24			
25				25			
26				26			
27				27			
28				28			
29				29			
OTHERS (ALUM. & G.M.S. PARTS)				30	MS01-P01	320	2
ITEM	FAB. DWG NO.	LENGTH (mm)	QTY	31	X86372-P01	320	1
46	BP-DA01		1	32	X86372-P02	320	1
	538X508			33	J60*38-001	15	1
47				34	J60*38-002	15	1
48				35			
49				36	GS01-K01	300	1
50	CE-002		1	37	AJ03-SU01-01	530	1
51				38			
52	PT-GL04-A08		1	39			
	614X565			40			
53	PT-GL01-B01		1	41			
	614X1105			42			
54	PT-GL05-A01		1	43			
	570X122			44			
55	PT-GL01-A01		1	45			
	614X840						

 美特鋁質有限公司 MIDI Aluminium Fabricator Ltd.				工程號 J856 地盘 天榮站	類別 制圖 李傳鵬 復核 練松文 批准 林仁安	物料號 M1 2022-11-26 2022-11-27 2022-11-28	圖號 CW-404 數量 - 單件重量 - (KG)
修改 日期	採用工廠 材料颜色 -UCT542919XL-3	地盘 <input checked="" type="checkbox"/>	图纸名称 单元组装图 材料 -				

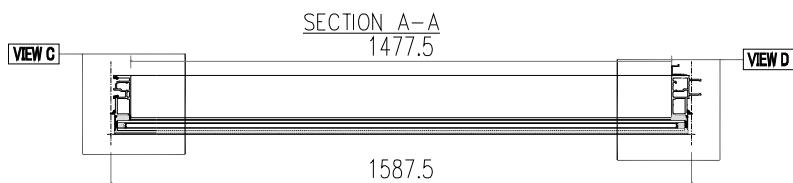
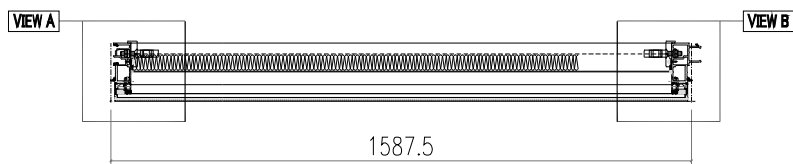
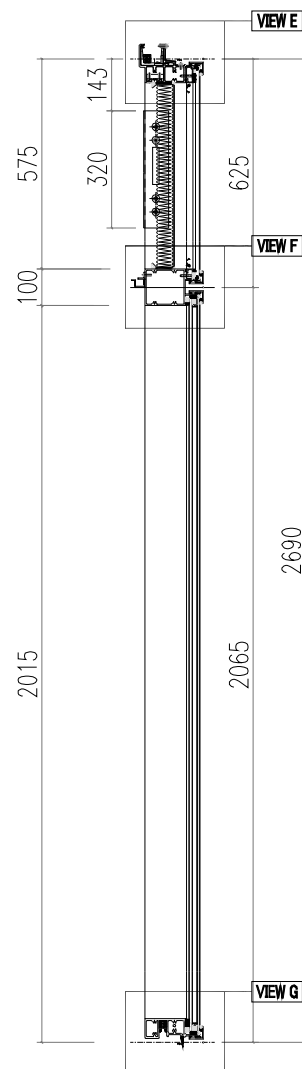
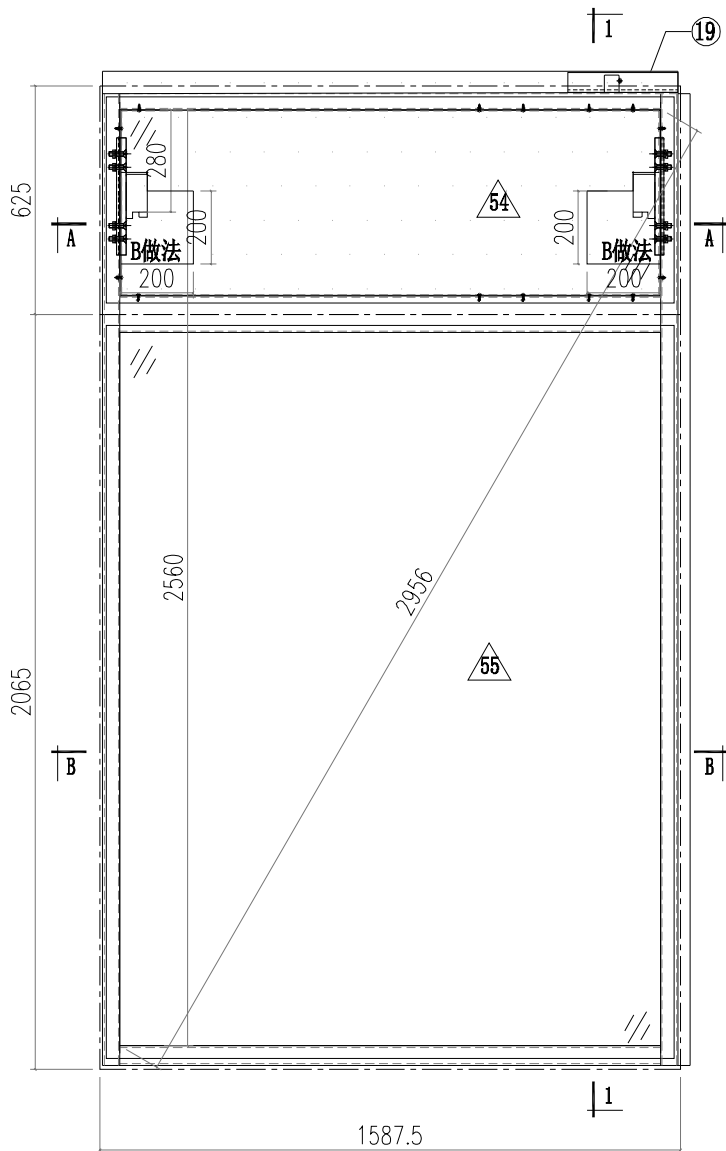

SECTION B-B

修改 日期
採用工廠 地盤 图纸名称 单元组裝图
材料颜色 -UCT542919XL-3 材料 -

批准 林仁安 2022-11-28 單件重量 - (KG)

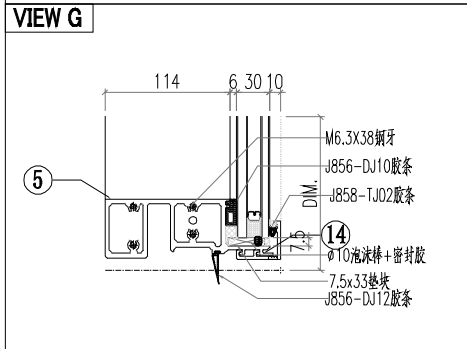
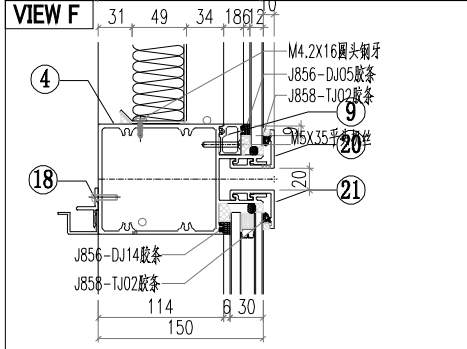
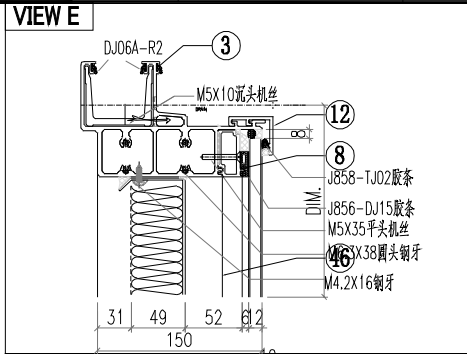
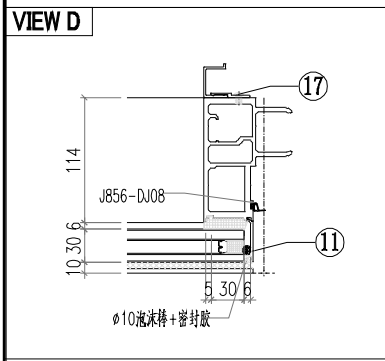
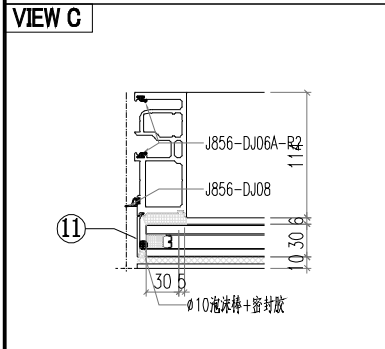
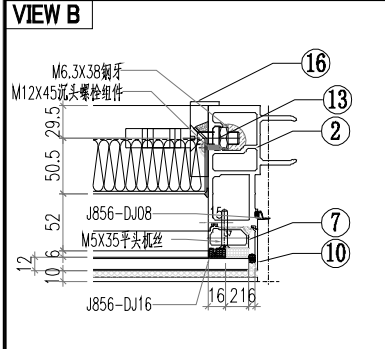
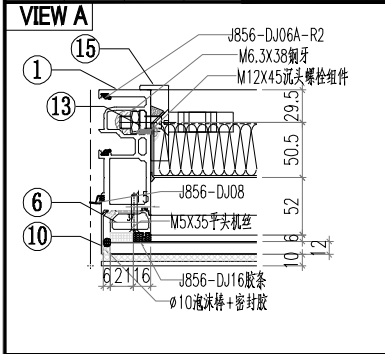

△ OTHERS (ALUM. & G.M.S. PARTS)			
ITEM	FAB. DWG NO.	LENGTH (mm)	QTY
46	BP-DA03		1
	1475.5X508		
47			
48			
49			
50			
51			
52			
53			
54	PT-GL04-A09		1
	1551.5X565		
55	PT-GL01-A09		1
	1551.5X2005		

○ ALUM. EXTRUSION			
ITEM	FAB. DWG NO.	LENGTH (mm)	QTY
1	AM02-SU01	2657	1
2	AM01-SU01	2657	1
3	AT01-SU01-003	1572.5	1
4	AT03-SU01-002	1561.5	1
5	AT02-SU02-002	1561.5	1
6	X86371-T04	580.5	1
7	X86371-T03	580.5	1
8	X86374-SU01-03	1475.5	1
9	X86375-SU01-03	1475.5	1
10	AC01-T01-02/AC01-T01R-2	597	2
11	AC01-P02-02/AC01-P02R-2	2037	2
12	X86412-SU01-03	1567.5	2
13	MS01-P01	320	2
14	X86412-SK01-03	1567.5	2
15	X86372-P01	320	1
16	X86372-P02	320	1
17	AJ04-P01	1950	1
18	AJ03-SU01-03	1467.5	1
19	GS01-K01	300	1
20			
21			
22			
23			
24			
25			
26			
27			
28			
29			
30			
31			
32			
33			
34			
35			
36			
37			
38			
39			
40			
41			
42			
43			
44			
45			

 美特鋁質有限公司 MIDI Aluminium Fabricator Ltd.		工程號 J856 地盤 天榮站	類別 制圖 李傳鵬 復核 練松文 批准 林仁安	物料號 M1 2022-11-26 2022-11-27 2022-11-28	圖號 CW-405 數量 - 單件重量 - (KG)
修改 日期	採用工廠 材料顏色 -UCT542919XL-3	地盤 <input checked="" type="checkbox"/> 图纸名称 单元组装图 材料 -			

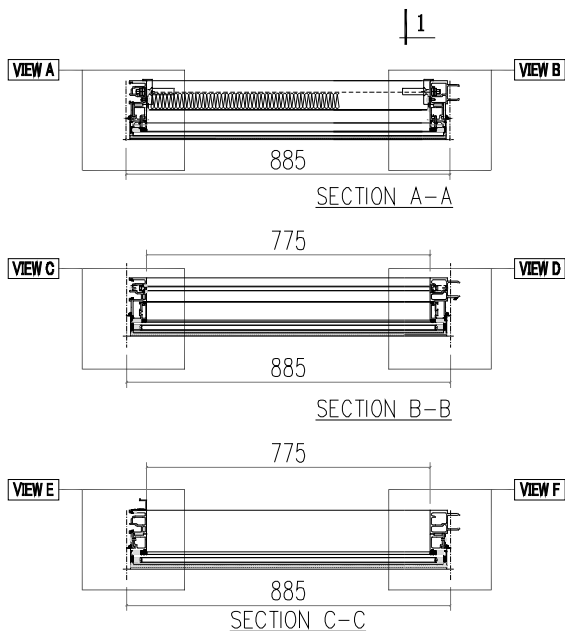
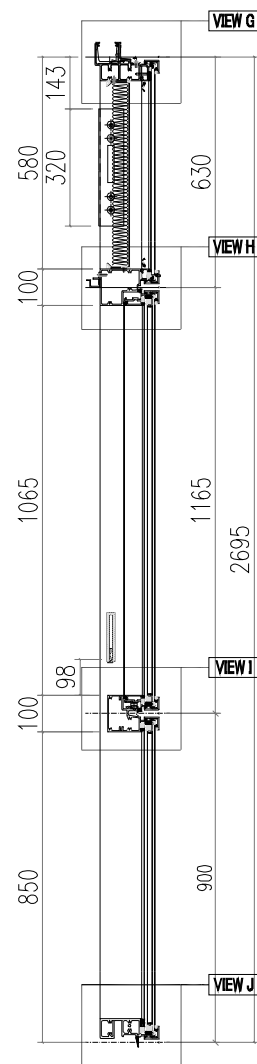
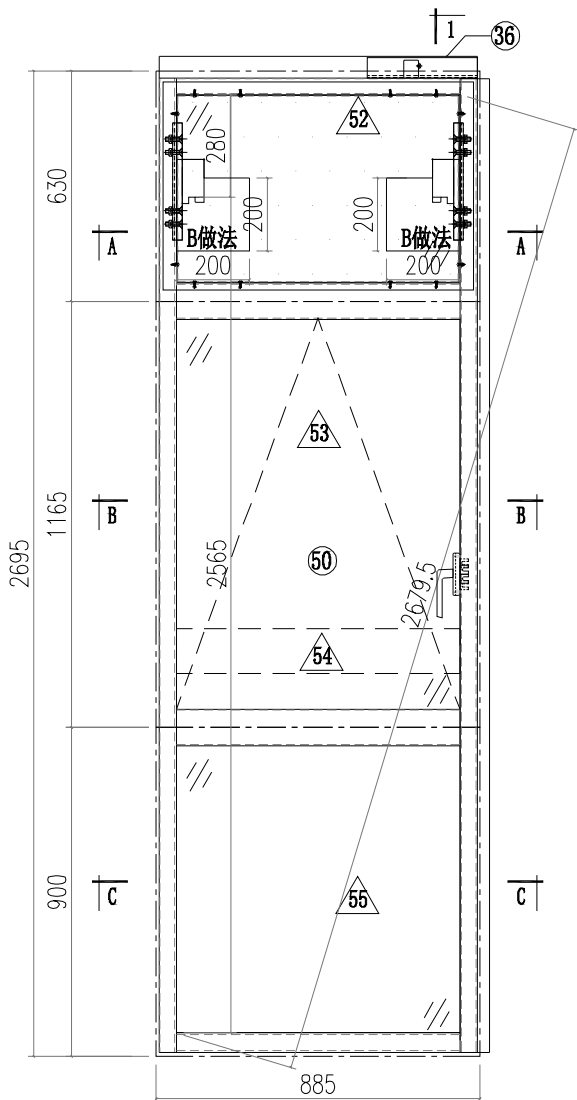

VIEW A

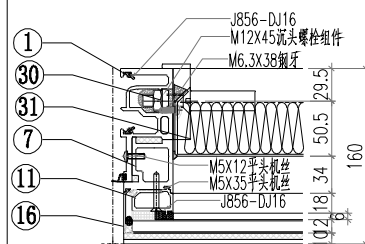

VIEW B

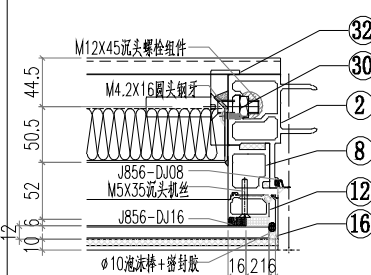

VIEW C

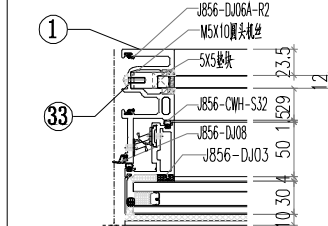

VIEW D

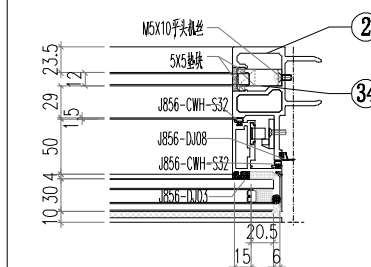

VIEW E

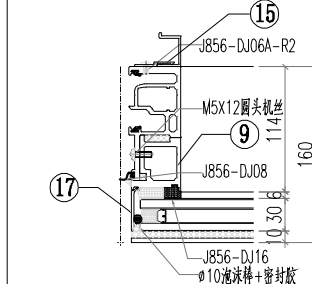

工程號	J856	類別		物料號	M1			
地盤	天榮站	制圖	李傳鵬	2022-11-26	圖號	CW-405		
修改		採用工廠	地盤	✓	日期			
日期		材料顏色	- UCT542919XL-3	材料	-	數量	-	
				復核	練松文	2022-11-27	單件重量	- (KG)
				批准	林仁安	2022-11-28		

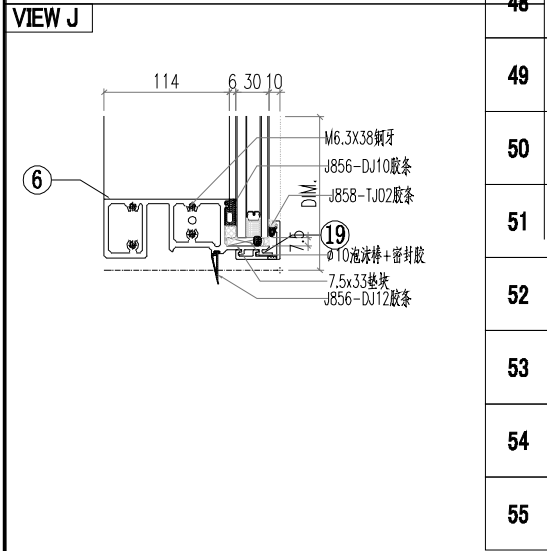
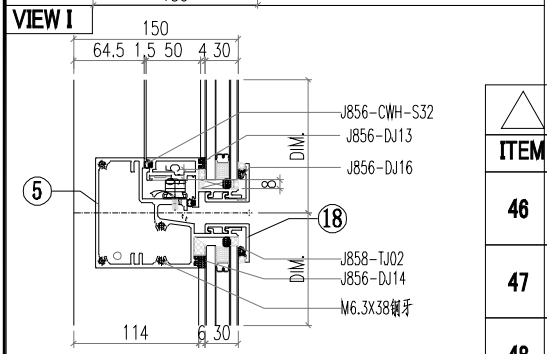
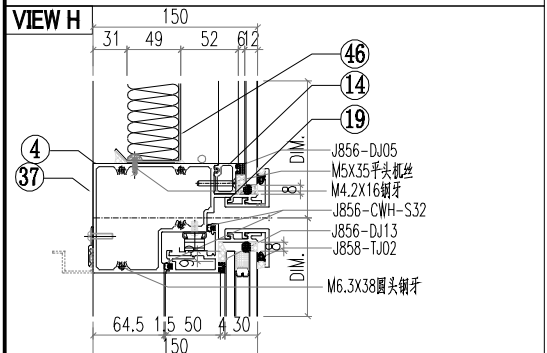
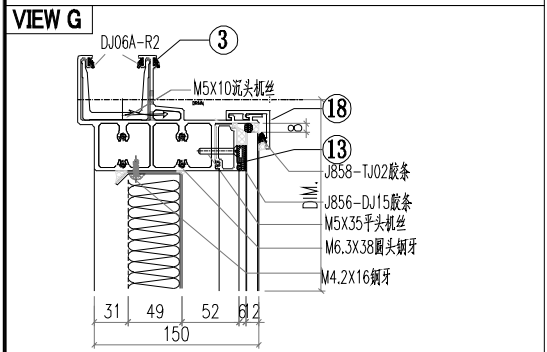
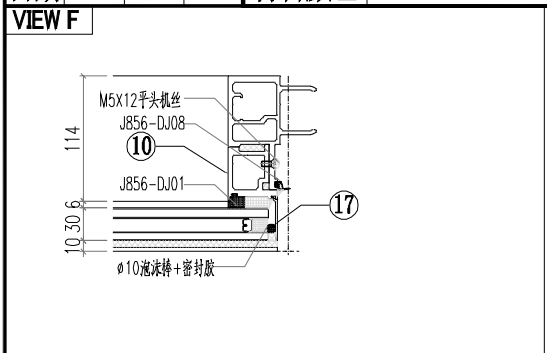

				ALUM. EXTRUSION			
ITEM	FAB. DWG NO.	LENGTH (mm)	QTY	ITEM	FAB. DWG NO.	LENGTH (mm)	QTY
1	X86365-SU02	2657	1	1			
2	X86364-SU02	2657	1	2			
3	AT01-SU01-004	870	1	3			
4	AT04-SU02-002	865	1	4			
5	AT05-SU02-002	865	1	5			
6	AT02-SU01-002	859	1	6			
7	AD06-T07	580	1	7			
8	AD06-T08	580	1	8			
9	AD06-P01	862	1	9			
10	AD06-P02	862	1	10			
11	X86371-T03	580.5	1	11			
12	X86371-T04	580.5	1	12			
13	X86374-SU01-04	773	1	13			
14	X86375-SU01-04	773	1	14			
15	AJ04-P02	1950	1	15			
16	AC01-T01-02/AC01-T01R-2	597	2	16			
17	AC01-P02-01/AC01-P02R-1	872	2	17			
18	X86412-SU01-04	865	2	18			
19	X86412-SK01-04	865	2	19			
20				20			
21				21			
22				22			
23				23			
24				24			
25				25			
26				26			
27				27			
28				28			
29				29			
OTHERS (ALUM. & G.M.S. PARTS)				30	MS01-P01	320	2
ITEM	FAB. DWG NO.	LENGTH (mm)	QTY	31	X86372-P01	320	1
46	BP-DA04		1	32	X86372-P02	320	1
	773X508			33	J60*38-001	15	1
47				34	J60*38-002	15	1
48				35			
49				36	GS01-K01	300	1
50				37	AJ03-SU01-04	765	1
51				38			
				39			
52	PT-GL04-A10		1	40			
	849X565			41			
53	PT-GL01-B06		1	42			
	849X1105			43			
54	PT-GL05-A02		1	44			
	805X122			45			
55	PT-GL01-A10		1				
	849X840						

 美特鋁質有限公司 MIDI Aluminium Fabricator Ltd.			工程號 J856 地盘 天榮站	類別 制圖 李傳鵬 復核 練松文 批准 林仁安	物料號 M1 2022-11-26 2022-11-27 2022-11-28	圖號 CW-406 數量 - 單件重量 - (KG)	
修改 日期	採用工廠 材料颜色 -UCT542919XL-3	地盤 <input checked="" type="checkbox"/>	图纸名称 单元组装图 材料 -				

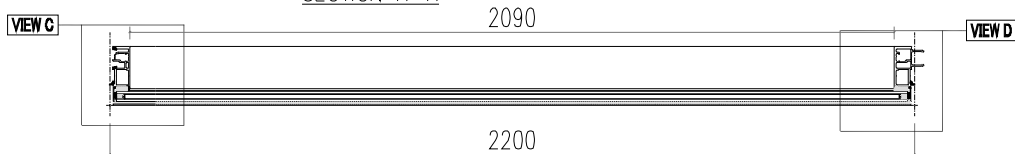
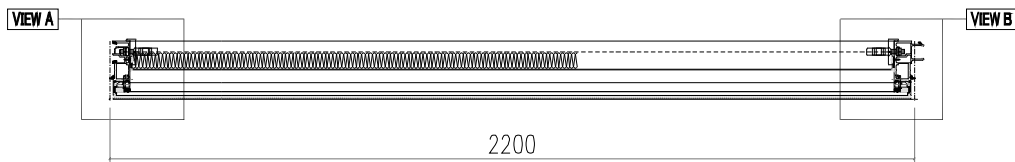
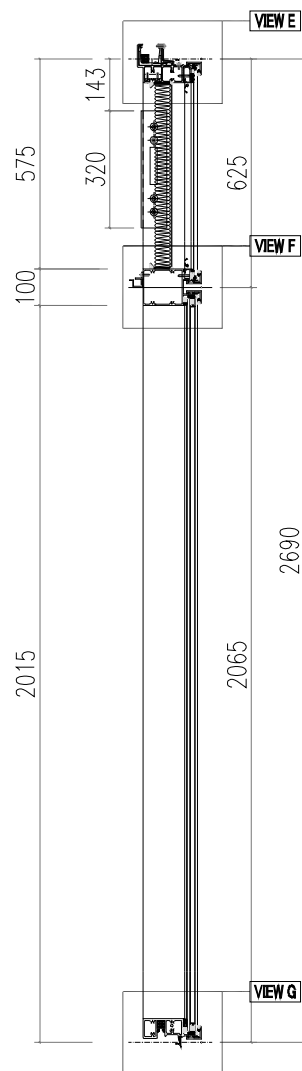
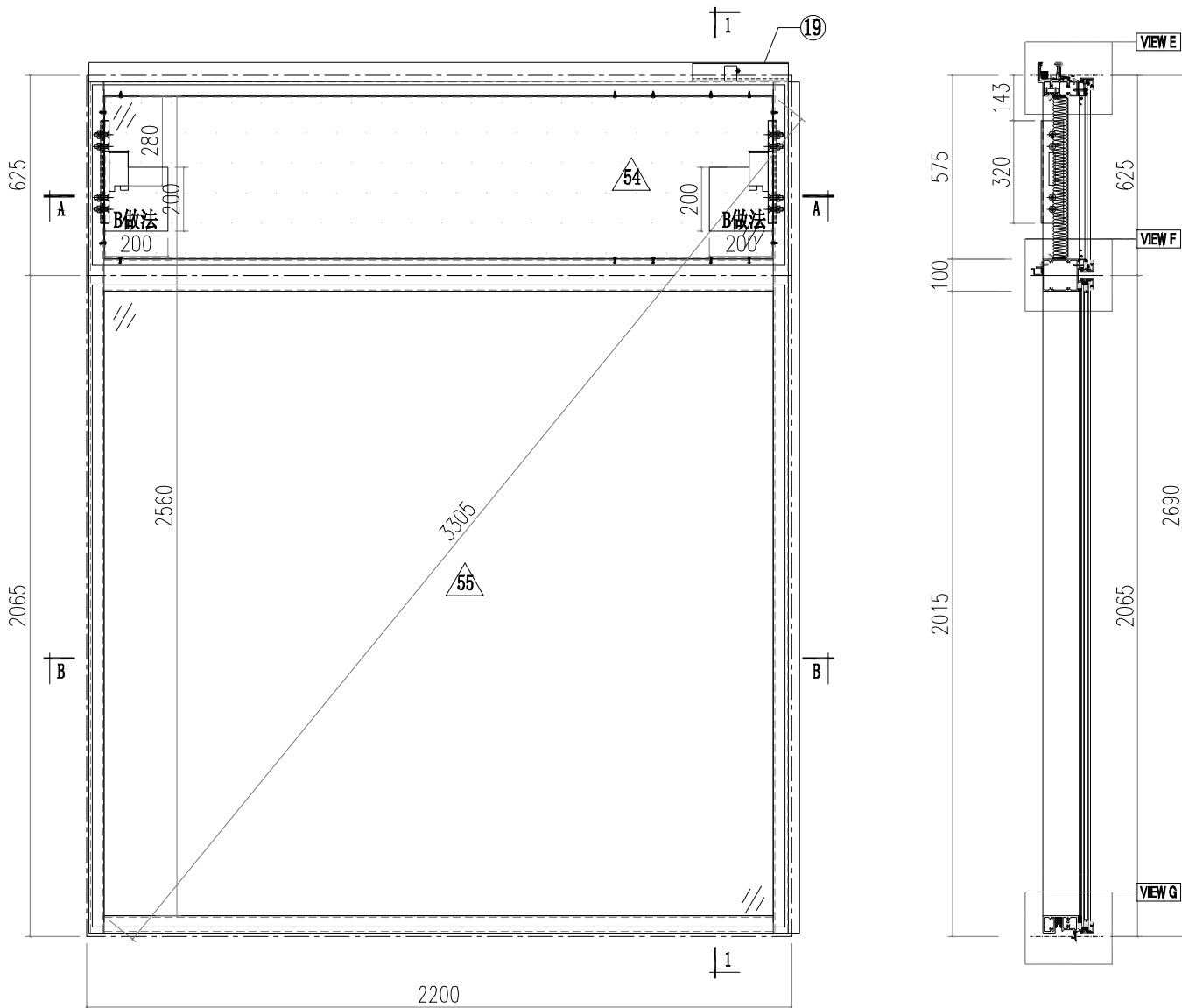

SECTION B-B

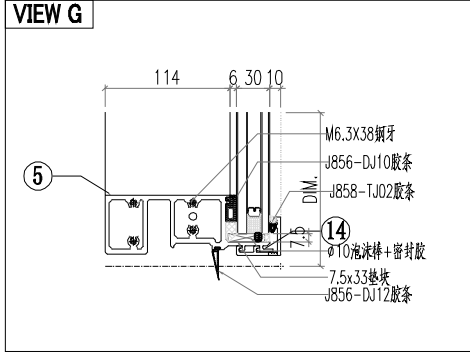
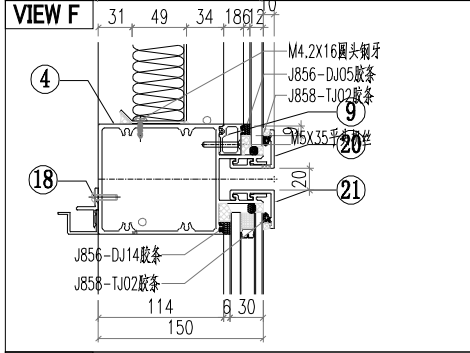
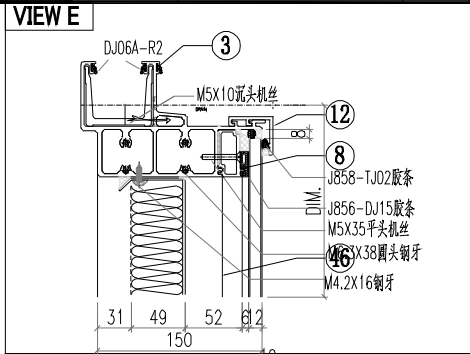
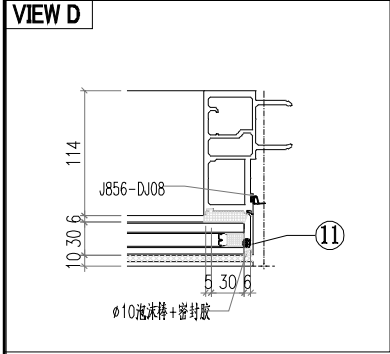
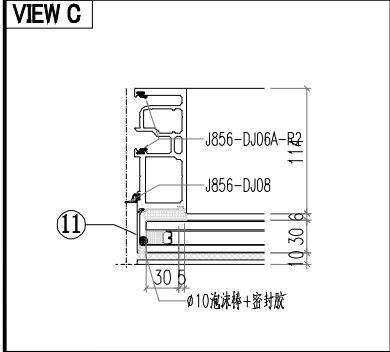
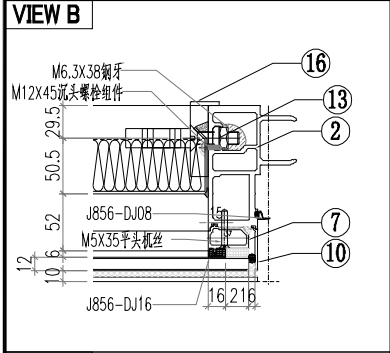
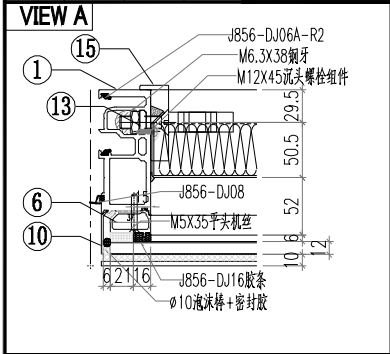

△ OTHERS (ALUM. & G.M.S. PARTS)

ITEM	FAB. DWG NO.	LENGTH (mm)	QTY
46	BP-DA05		1
	2088X508		
47			
48			
49			
50			
51			
52			
53			
54	PT-GL04-A11		1
	2164X565		
55	PT-GL01A-A11		1
	2164X2005		

○ ALUM. EXTRUSION

ITEM	FAB. DWG NO.	LENGTH (mm)	QTY
1	AM02-SU01	2657	1
2	AM01-SU02	2657	1
3	AT01-SU01-005	2185	1
4	AT03-SU01-003	2174	1
5	AT02-SU02-003	2174	1
6	X86371-T04	580.5	1
7	X86371-T03	580.5	1
8	X86374-SU01-05	2088	1
9	X86375-SU01-05	2088	1
10	AC01-T01-02/AC01-T01R-2	597	2
11	AC01-P02-02/AC01-P02R-2	2037	2
12	X86412-SU01-05	2180	2
13	MS01-P01	320	2
14	X86412-SK01-05	2180	2
15	X86372-P01	320	1
16	X86372-P02	320	1
17			
18	AJ03-SU01-05	2080	1
19	GS01-K01	300	1
20			
21			
22			
23			
24			
25			
26			
27			
28			
29			
30			
31			
32			
33			
34			
35			
36			
37			
38			
39			
40			
41			
42			
43			
44			
45			

 美特鋁質有限公司 MIDI Aluminium Fabricator Ltd.			工程號 J856 地盘 天榮站 图纸名称 单元组装图 材料 -	類別 制圖 李傳鵬 復核 練松文 批准 林仁安	物料號 M1 2022-11-26 2022-11-27 2022-11-28	圖號 CW-407 數量 - 單件重量 - (KG)
修改 日期	採用工廠 材料颜色 -UCT542919XL-3	地盘 <input checked="" type="checkbox"/>				

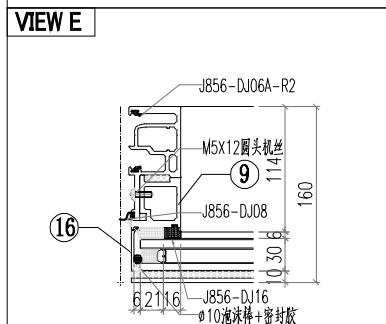
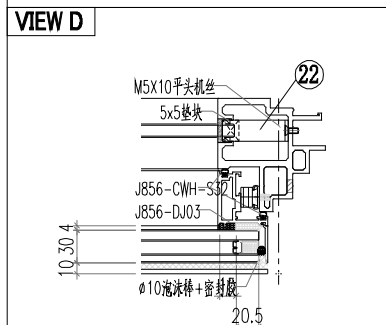
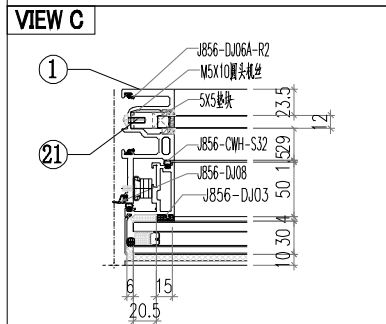
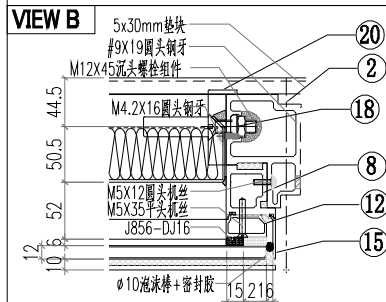
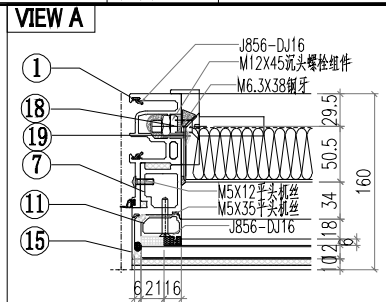
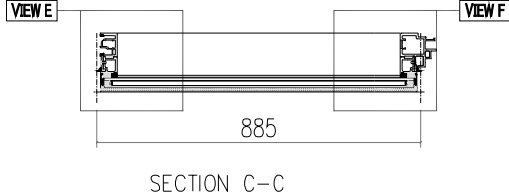
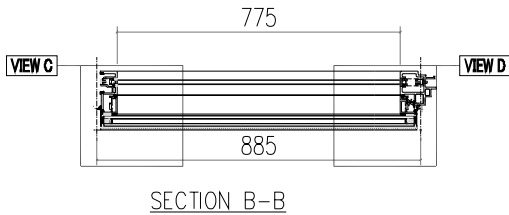
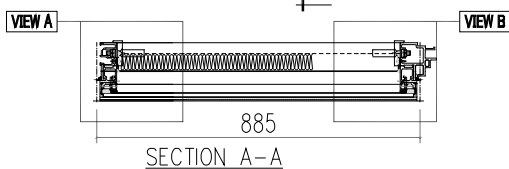
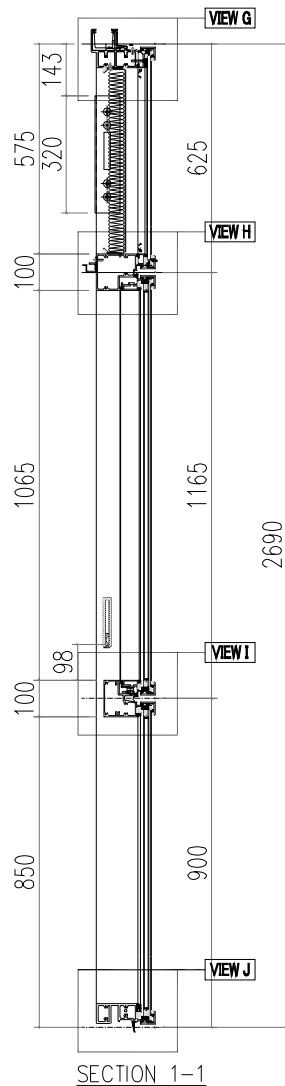
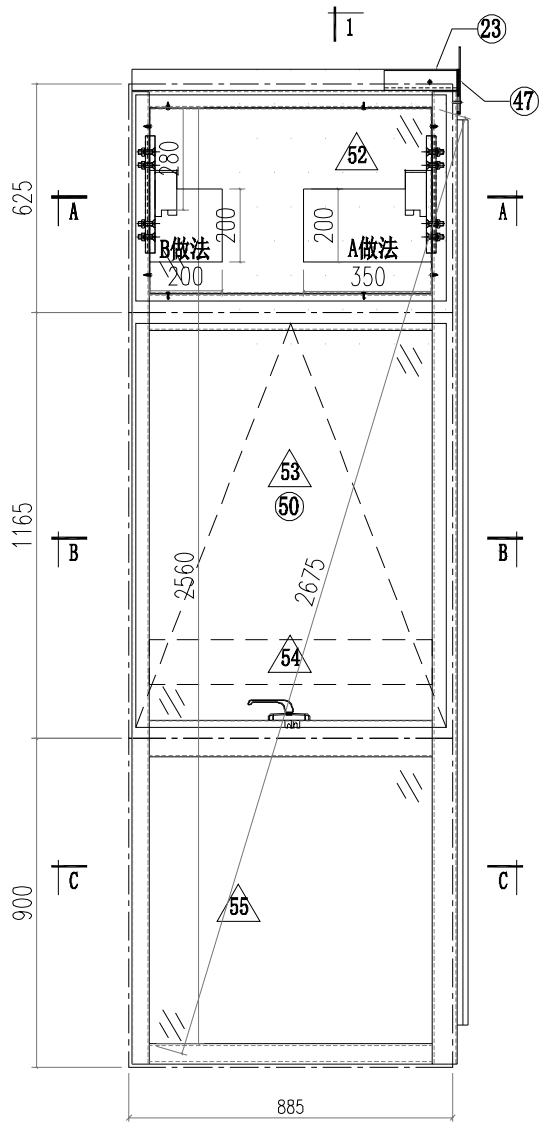

修改 日期
採用工廠 地盤 材料顏色 - UCT542919XL-3

图纸名称 单元组裝圖
材料 -

數量 -
單件重量 - (KG)

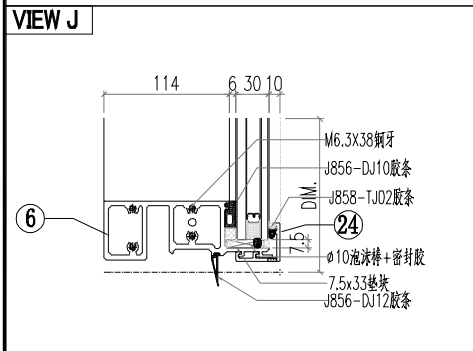
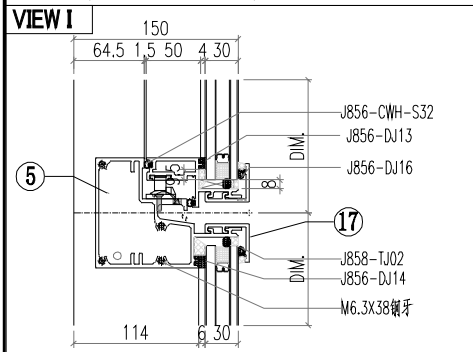
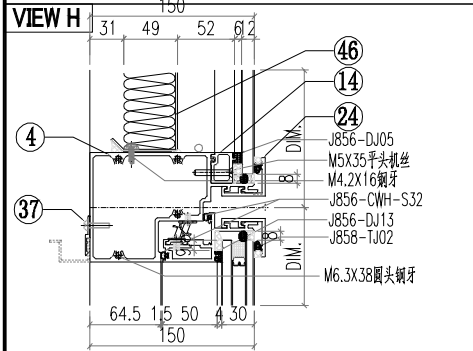
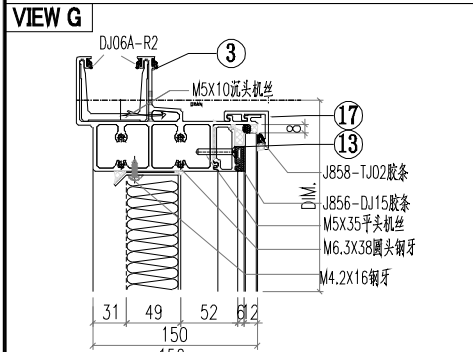
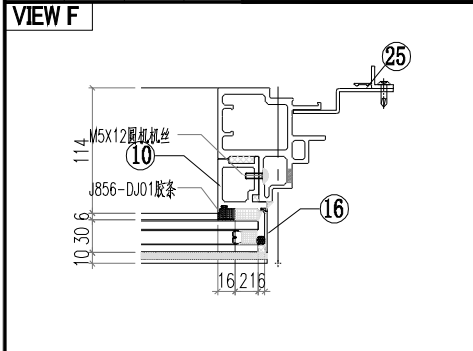

ALUM. EXTRUSION

ITEM	FAB. DWG NO.	LENGTH (mm)	QTY
1	X86365-SU03	2657	1
2	X86367-SU02	2657	1
3	AT01-SU03-002	905.5	1
4	AT04-SU02-002	865	1
5	AT05-SU02-002	865	1
6	AT02-SU01-002	859	1
7	AD06-T07	580	1
8	AD06-T08	580	1
9	AD06-P01	862	1
10	AD06-P02	862	1
11	X86371-T03	580.5	1
12	X86371-T04	580.5	1
13	X86374-SU01-04	773	1
14	X86375-SU01-04	773	1
15	AC01-T01-02/AC01-T01R-2	597	2
16	AC01-P02-01/AC01-P02R-1	872	2
17	X86412-SU01-04	865	2
18	MS01-P01	320	2
19	X86372-P01	320	1
20	X86372-P02	320	1
21	J60*38-001	15	1
22	J60*38-003	15	1
23	GS01-K02	150	1
24	X86412-SK01-04	865	2
25	AX04-P03	1950	1
26			
27			
28			
29			
30			

OTHERS (ALUM. & G.M.S. PARTS)			
ITEM	FAB. DWG NO.	LENGTH (mm)	QTY
31			
32			
33			
34			
35			
36			
37	AJ03-SU01-04	765	1
38			
39			
40	CE-011		1
41			
42			
43			
44			
45			
46	BP-DA04		1
47	773X508		1
48	LB-P01		1
49			
50			
51			
52	PT-GL04-A10		1
53	849X565		1
54	PT-GL01-B06		1
55	849X1105		1
56	PT-GL05-A02		1
57	805X122		1
58	PT-GL01-A10		1
59	849X840		1

 美特鋁質有限公司 MIDI Aluminium Fabricator Ltd.		工程號 J856 地盘 天榮站	類別 制圖 李傳鵬 復核 練松文 批准 林仁安	物料號 M1 圖號 CW-408 數量 - 單件重量 - (KG)
修改 日期	採用工廠 材料颜色 -UCT542919XL-3	图纸名称 单元组装图 材料 -		

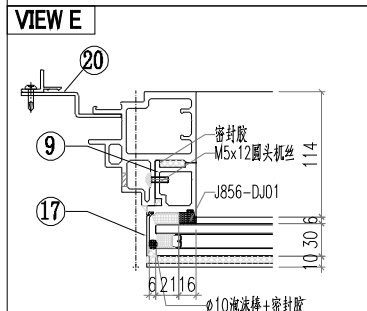
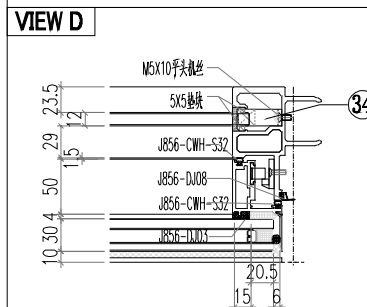
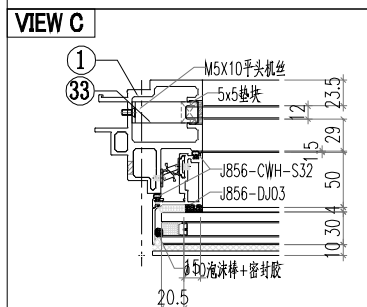
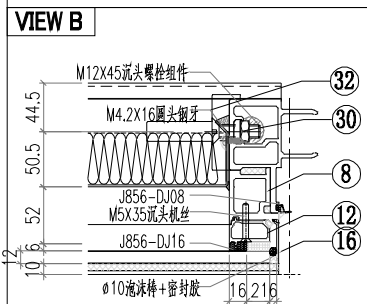
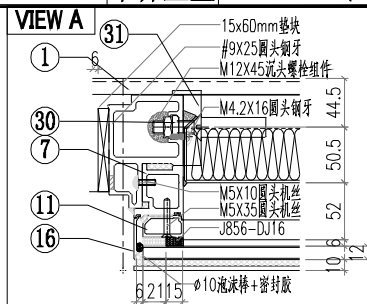
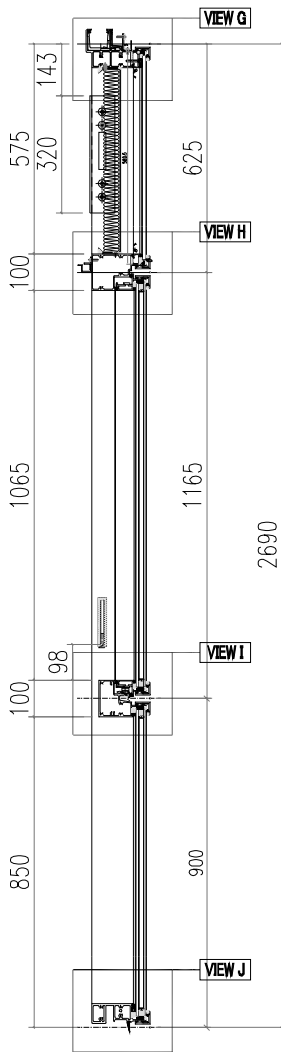
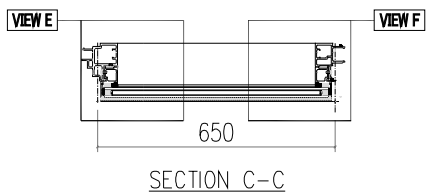
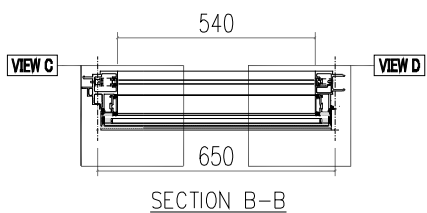
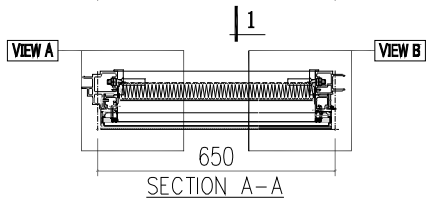
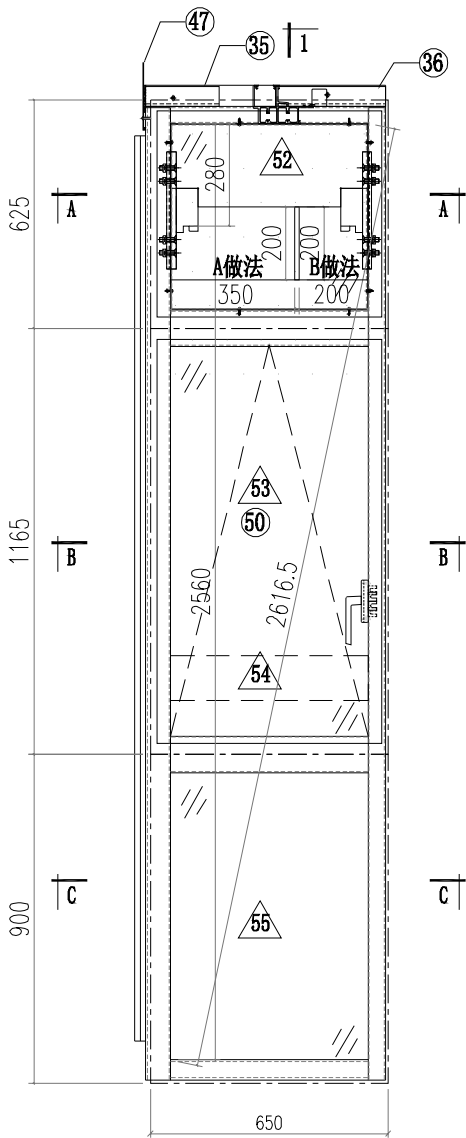

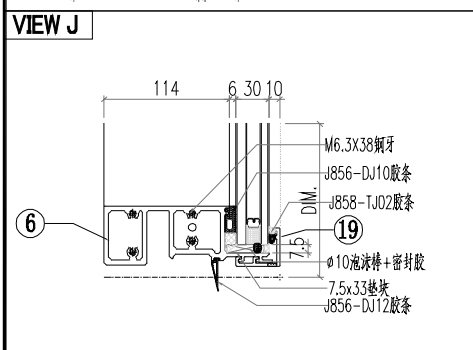
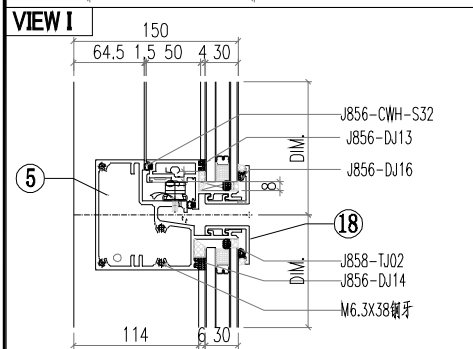
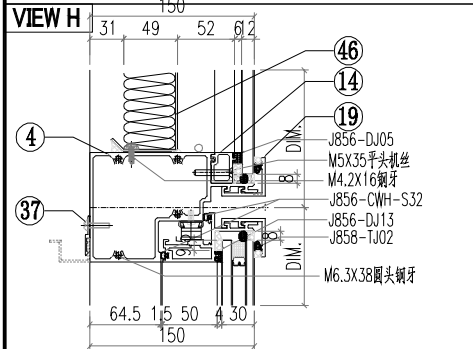
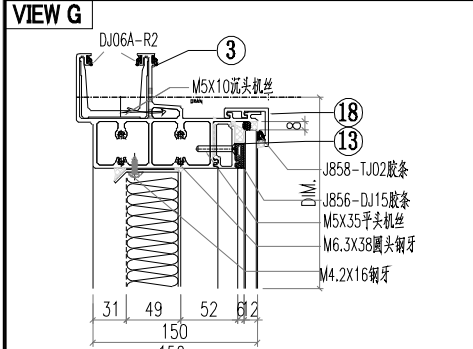
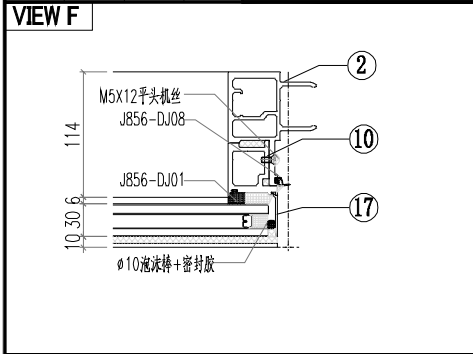

ALUM. EXTRUSION

ITEM	FAB. DWG NO.	LENGTH (mm)	QTY
1	X86367-SU03	2657	1
2	X86364-SU02	2657	1
3	AT01-SU02-001	670.5	1
4	AT04-SU02-001	630	1
5	AT05-SU02-001	630	1
6	AT02-SU01-001	624	1
7	AD06-T07	580	1
8	AD06-T08	580	1
9	AD06-P01	862	1
10	AD06-P02	862	1
11	X86371-T03	580.5	1
12	X86371-T04	580.5	1
13	X86374-SU01-01	538	1
14	X86375-SU01-01	538	1
15			
16	AC01-T01-02/AC01-T01R-2	597	2
17	AC01-P02-01/AC01-P02R-1	872	2
18	X86412-SU01-01	630	2
19	X86412-SK01-01	630	2
20	AX04-P04	1950	1
21			
22			
23			
24			
25			
26			
27			
28			
29			

OTHERS (ALUM. & G.M.S. PARTS)

ITEM	FAB. DWG NO.	LENGTH (mm)	QTY
30	MS01-P01	320	2
31	X86372-P01	320	1
32	X86372-P02	320	1
33	J60*38-003	15	1
34	J60*38-002	15	1
35	GS01-K02	150	1
36	GS01-K01	300	1
37	AJ03-SU01-1	530	1
38			
39			
40	CE-003		
41			
42			
43			
44			
45			
46	BP-DA01		1
47	538X508		1
48	LB-P02		1
49			
50			
51			
52	PT-GL04-A08 614X565		1
53	PT-GL01-B01 614X1105		1
54	PT-GL05-A01 570X122		1
55	PT-GL01-A01 614X840		1

 美特鋁質有限公司 MIDI Aluminium Fabricator Ltd.		工程號 J856 地盤 天榮站	類別 制圖 李傳鵬 復核 練松文 批准 林仁安	物料號 M1 2022-11-26 2022-11-27 2022-11-28	圖號 CW-409 數量 - 單件重量 - (KG)
修改 日期	採用工廠 材料顏色 -UCT542919XL-3	地盤 <input checked="" type="checkbox"/> 图纸名称 单元组装图 材料 -			

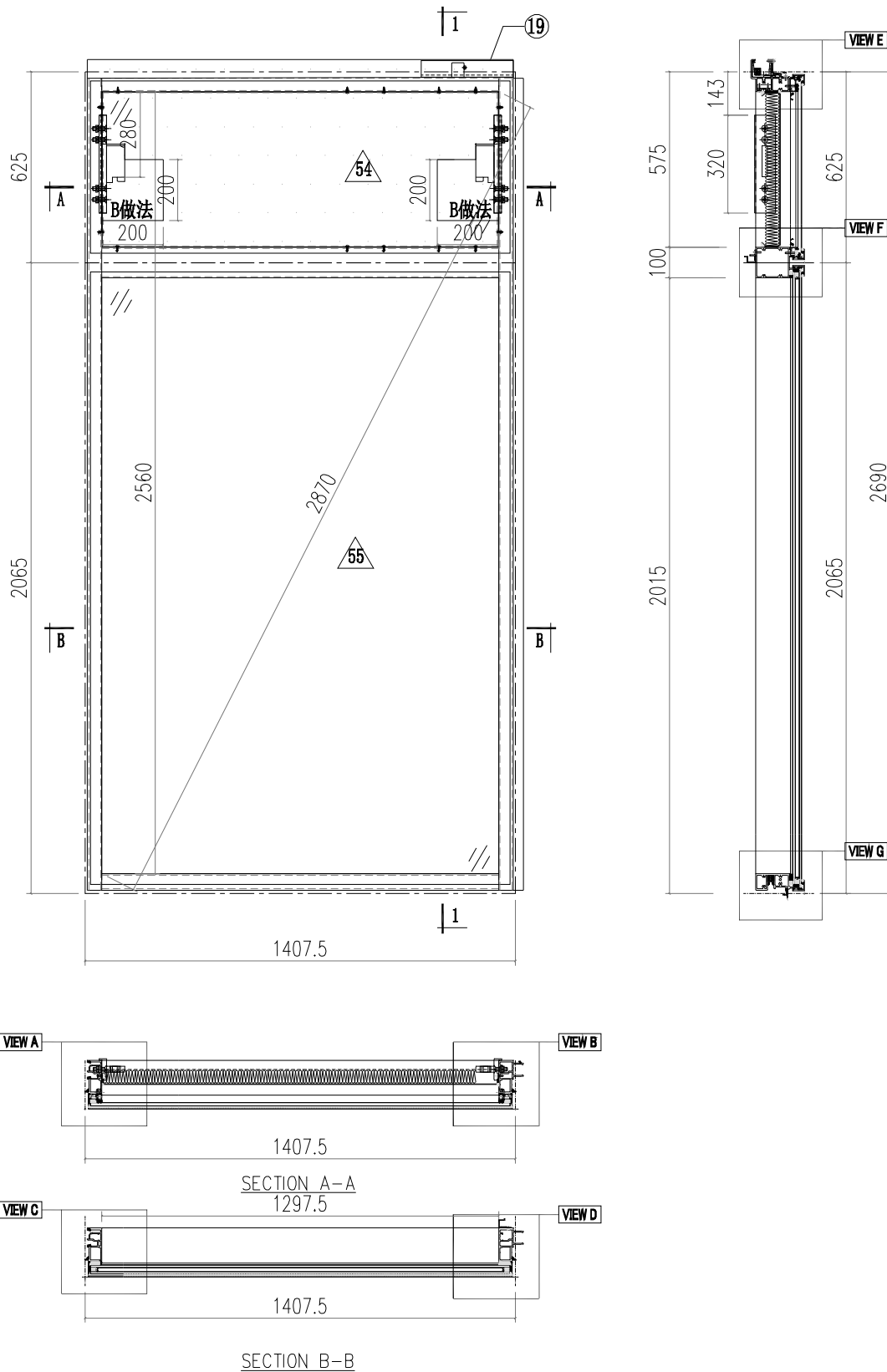

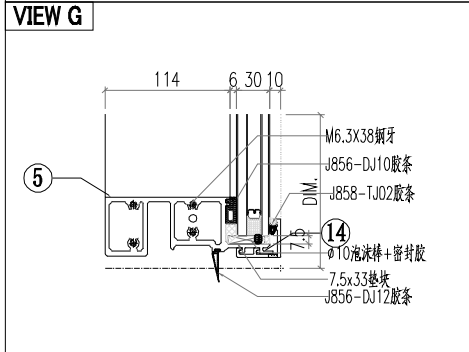
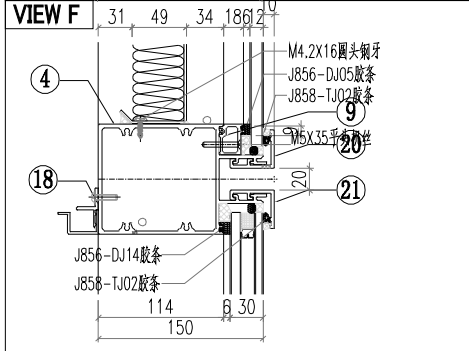
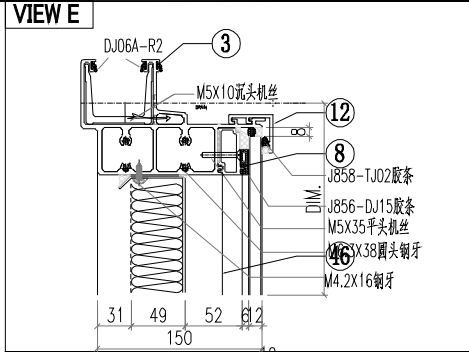
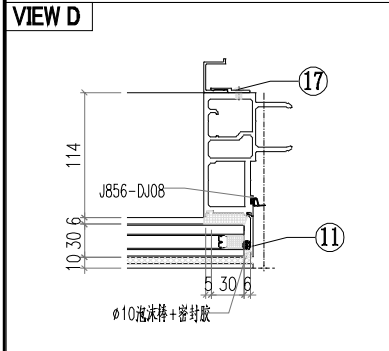
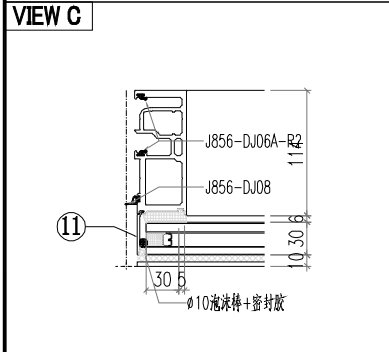
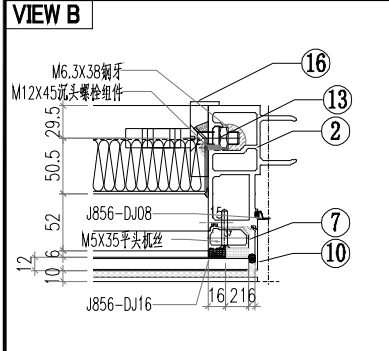
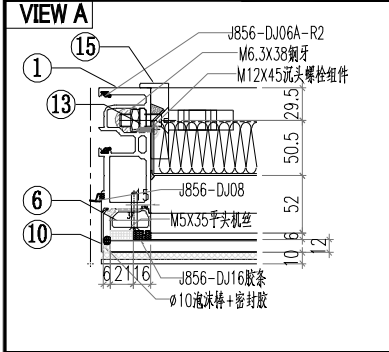

△ OTHERS (ALUM. & G.M.S. PARTS)			
ITEM	FAB. DWG NO.	LENGTH (mm)	QTY
46	BP-DA06		1
	1295.5X508		
47			
48			
49			
50			
51			
52			
53			
54	PT-GL04-A12		1
	1371.5X565		
55	PT-GL01-A12		1
	1371.5X2005		

○ ALUM. EXTRUSION			
ITEM	FAB. DWG NO.	LENGTH (mm)	QTY
1	AM02-SU01	2657	1
2	AM01-SU01	2657	1
3	AT01-SU01-006	1392.5	1
4	AT03-SU01-004	1381.5	1
5	AT02-SU02-004	1381.5	1
6	X86371-T04	580.5	1
7	X86371-T03	580.5	1
8	X86374-SU01-06	1295.5	1
9	X86375-SU01-06	1295.5	1
10	AC01-T01-02/AC01-T01R-2	597	2
11	AC01-P02-02/AC01-P02R-2	2037	2
12	X86412-SU01-06	1387.5	2
13	MS01-P01	320	2
14	X86412-SK01-06	1387.5	2
15	X86372-P01	320	1
16	X86372-P02	320	1
17	AJ04-P01	1950	1
18	AJ03-SU01-06	1287.5	1
19	GS01-K01	300	1
20			
21			
22			
23			
24			
25			
26			
27			
28			
29			
30			
31			
32			
33			
34			
35			
36			
37			
38			
39			
40			
41			
42			
43			
44			
45			

 美特鋁質有限公司 MIDI Aluminium Fabricator Ltd.		工程號 J856 地盤 天榮站	類別 制圖 李傳鵬 復核 練松文 批准 林仁安	物料號 M1 2022-11-26 2022-11-27 2022-11-28	圖號 CW-410 數量 - 單件重量 - (KG)
修改 日期	採用工廠 材料顏色 - UCT542919XL-3	地盤 <input checked="" type="checkbox"/> 图纸名称 单元组装图 材料 -			

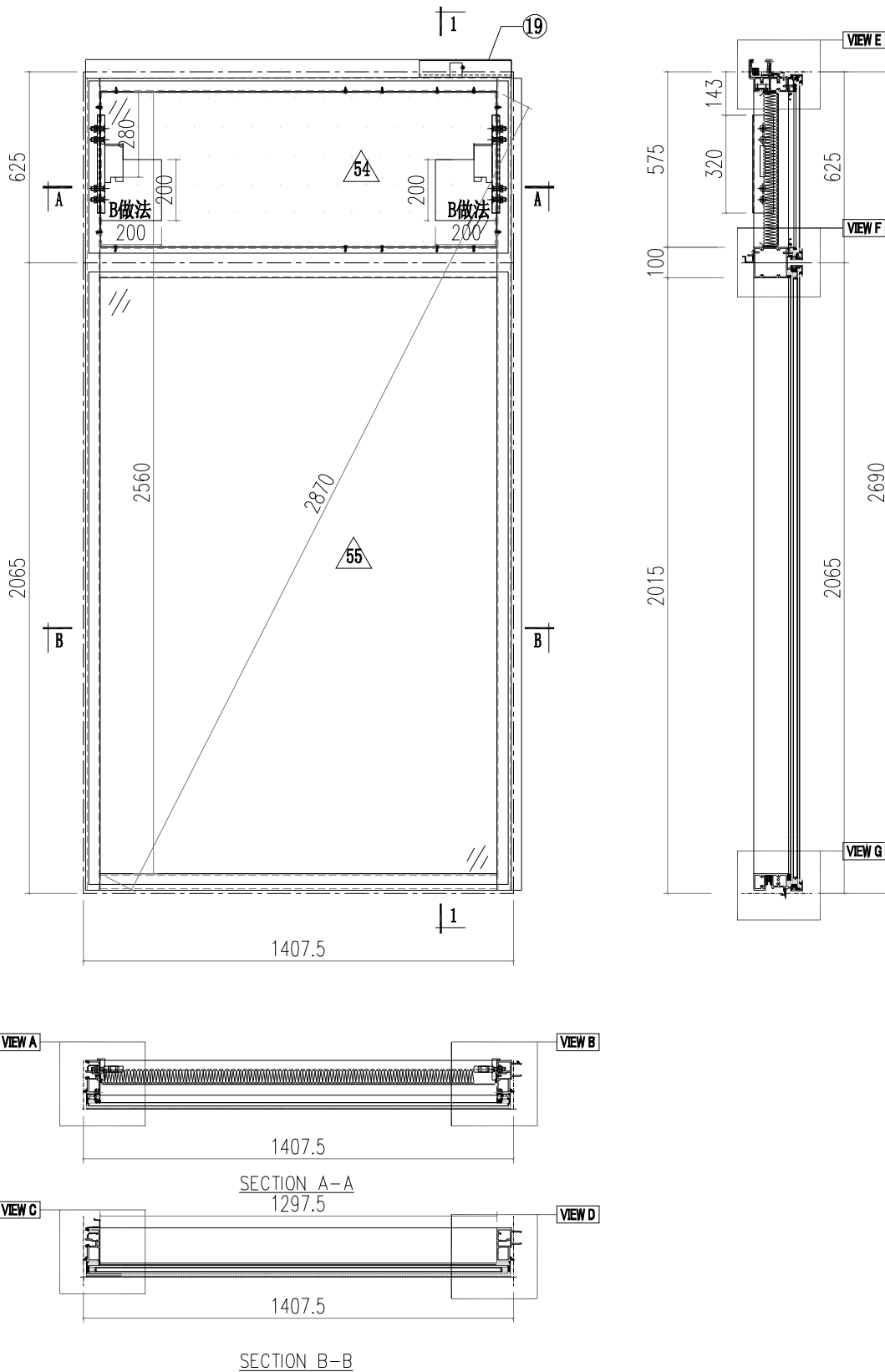

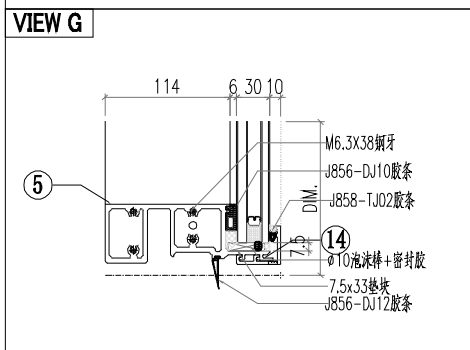
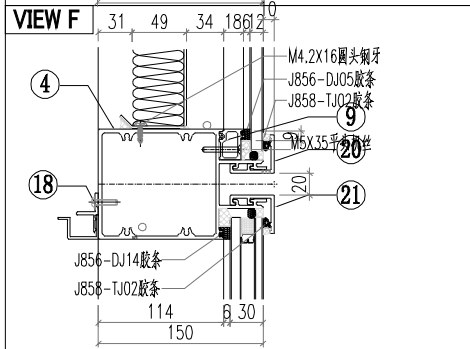
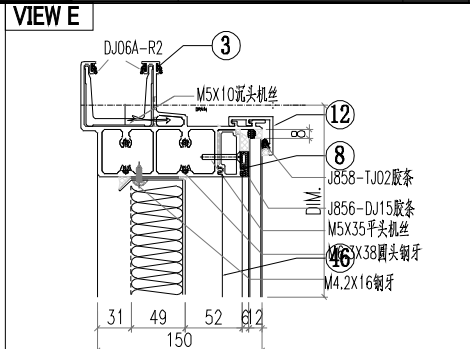
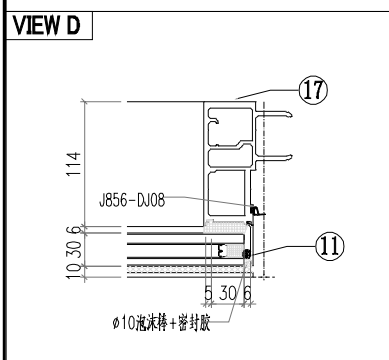
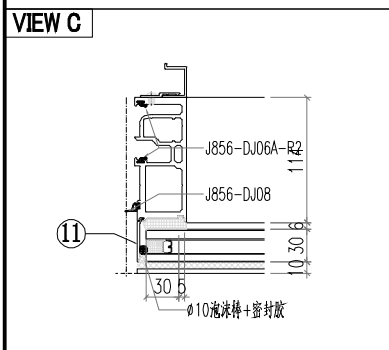
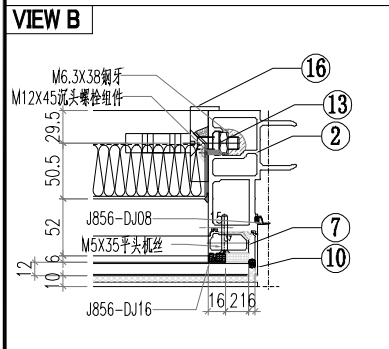
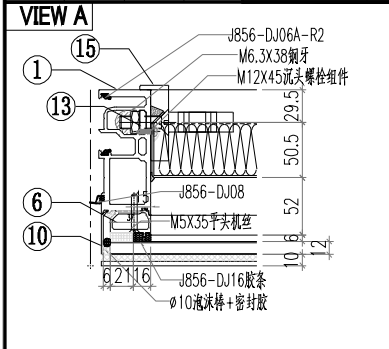

△ OTHERS (ALUM. & G.M.S. PARTS)			
ITEM	FAB. DWG NO.	LENGTH (mm)	QTY
46	BP-DA06		1
	1295.5X508		
47			
48			
49			
50			
51			
52			
53			
54	PT-GL04-A12		1
	1371.5X565		
55	PT-GL01-A12		1
	1371.5X2005		

○ ALUM. EXTRUSION			
ITEM	FAB. DWG NO.	LENGTH (mm)	QTY
1	AM02-SU02	2657	1
2	AM01-SU02	2657	1
3	AT01-SU01-006	1392.5	1
4	AT03-SU01-004	1381.5	1
5	AT02-SU02-004	1381.5	1
6	X86371-T04	580.5	1
7	X86371-T03	580.5	1
8	X86374-SU01-06	1295.5	1
9	X86375-SU01-06	1295.5	1
10	AC01-T01-02/AC01-T01R-2	597	2
11	AC01-P02-02/AC01-P02R-2	2037	2
12	X86412-SU01-06	1387.5	2
13	MS01-P01	320	2
14	X86412-SK01-06	1387.5	2
15	X86372-P01	320	1
16	X86372-P02	320	1
17	AJ04-P02	1950	1
18	AJ03-SU01-06	1287.5	1
19	GS01-K01	300	1
20			
21			
22			
23			
24			
25			
26			
27			
28			
29			
30			
31			
32			
33			
34			
35			
36			
37			
38			
39			
40			
41			
42			
43			
44			
45			

 美特鋁質有限公司 MIDI Aluminium Fabricator Ltd.		工程號 J856 地盘 天榮站 图纸名称 单元组装图 材料 -	類別 制圖 李傳鵬 復核 練松文 批准 林仁安	物料號 M1 2022-11-26 2022-11-27 2022-11-28	圖號 CW-411 數量 - 單件重量 - (KG)
修改 日期	採用工廠 材料颜色 - UCT542919XL-3	地盤 <input checked="" type="checkbox"/>			

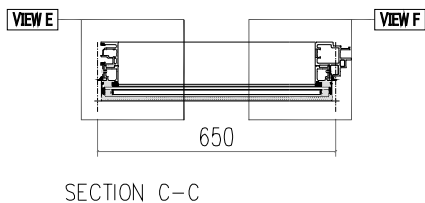
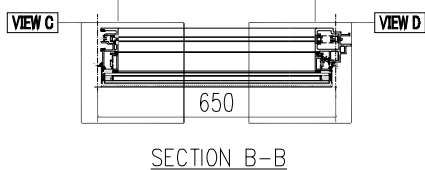
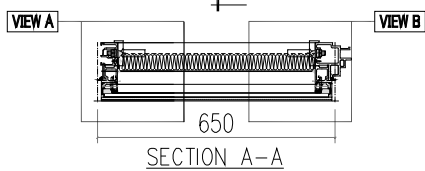
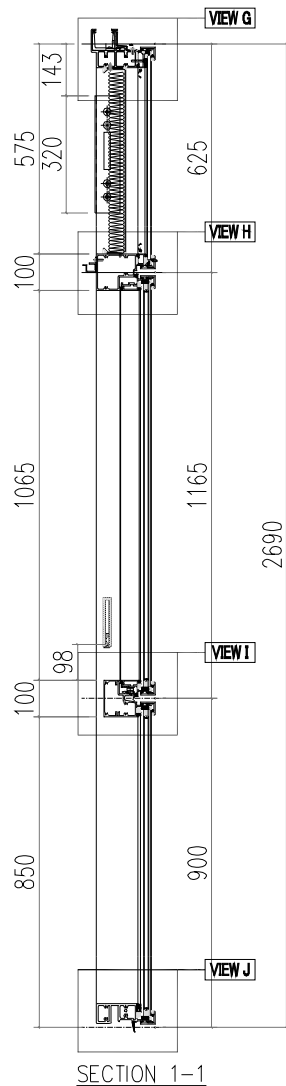
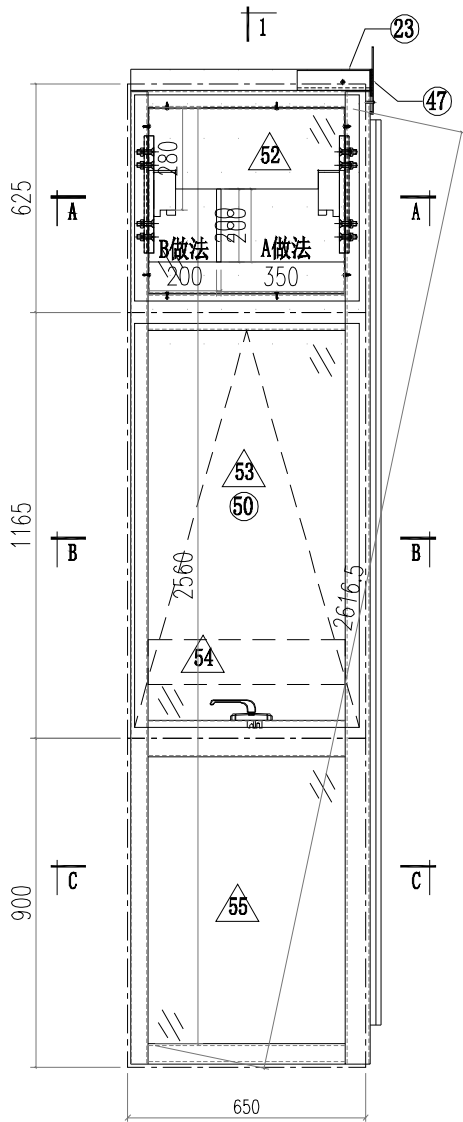

VIEW A

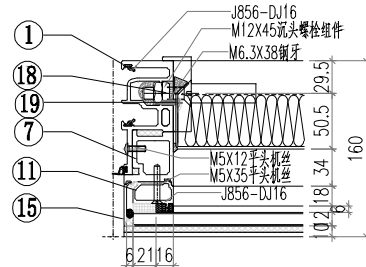

VIEW B

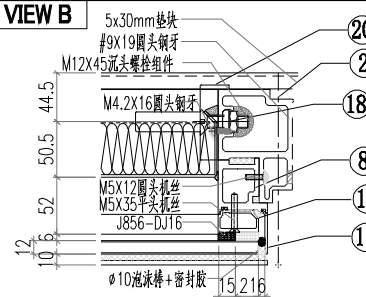

VIEW C

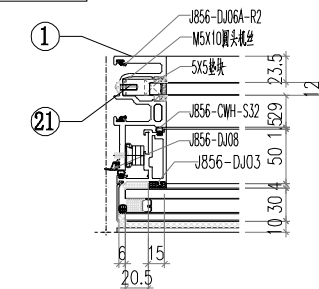

VIEW D

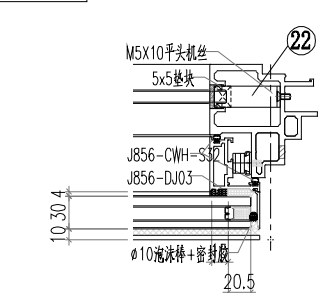

VIEW E

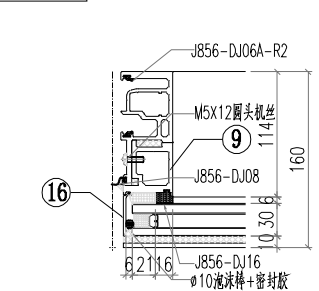

修改 日期
採用工廠 地盤 材料顏色 - UCT542919XL-3

圖紙名稱 單元組裝圖
材料 -

數量 -
單件重量 - (KG)

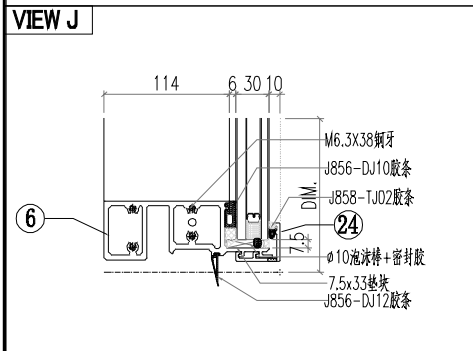
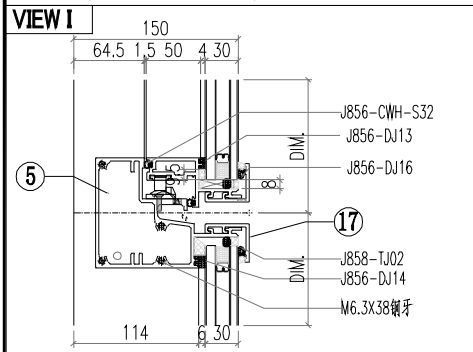
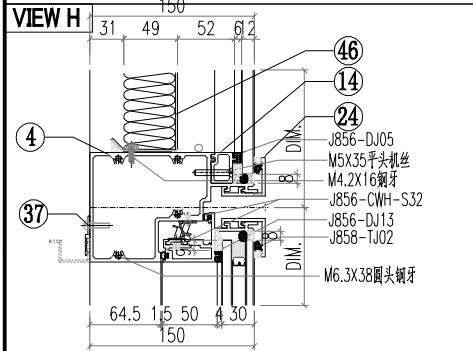
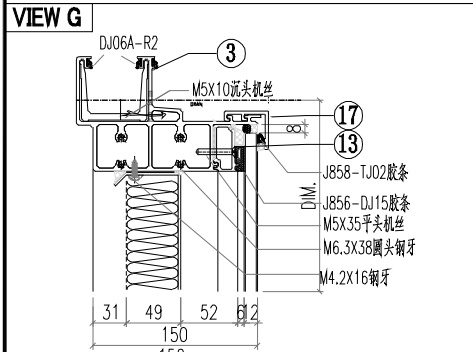
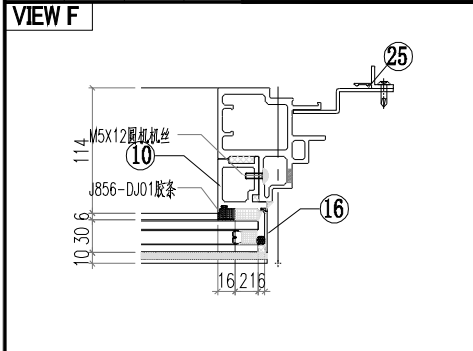

ALUM. EXTRUSION

ITEM	FAB. DWG NO.	LENGTH (mm)	QTY
1	X86365-SU03	2657	1
2	X86367-SU02	2657	1
3	AT01-SU03-001	670.5	1
4	AT04-SU02-001	630	1
5	AT05-SU02-001	630	1
6	AT02-SU01-001	624	1
7	AD06-T07	580	1
8	AD06-T08	580	1
9	AD06-P01	862	1
10	AD06-P02	862	1
11	X86371-T03	580.5	1
12	X86371-T04	580.5	1
13	X86374-SU01-01	538	1
14	X86375-SU01-01	538	1
15	AC01-T01-02/AC01-T01R-2	597	2
16	AC01-P02-01/AC01-P02R-1	872	2
17	X86412-SU01-01	630	2
18	MS01-P01	320	2
19	X86372-P01	320	1
20	X86372-P02	320	1
21	J60*38-001	15	1
22	J60*38-003	15	1
23	GS01-K02	150	1
24	X86412-SK01-01	630	2
25	AX04-P03	1950	1
26			
27			
28			
29			
30			

OTHERS (ALUM. & G.M.S. PARTS)			
ITEM	FAB. DWG NO.	LENGTH (mm)	QTY
46	BP-DA01		1
	538X508		
47	LB-P01		1
48			
49			
50	CE-003		1
51			
52	PT-GL04-A08		1
	614X565		
53	PT-GL01-B01		1
	614X1105		
54	PT-GL05-A01		1
	570X122		
55	PT-GL01-A01		1
	614X840		

31			
32			
33			
34			
35			
36			
37	AJ03-SU01-01	530	1
38			
39			
40			
41			
42			
43			
44			
45			

 美特鋁質有限公司 MIDI Aluminium Fabricator Ltd.		工程號 J856 地盘 天榮站	類別 制圖 李傳鵬 2022-11-26	物料號 M1 圖號 CW-412
修改 日期	採用工廠 材料颜色 -UCT542919XL-3	图纸名称 单元组装图 材料 -	復核 練松文 2022-11-27 批准 林仁安 2022-11-28	數量 - 單件重量 - (KG)

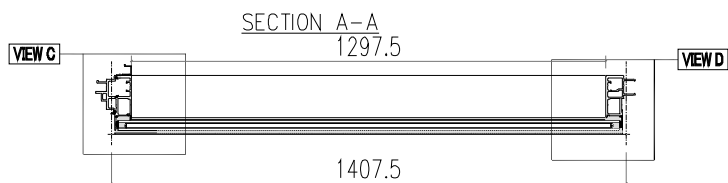
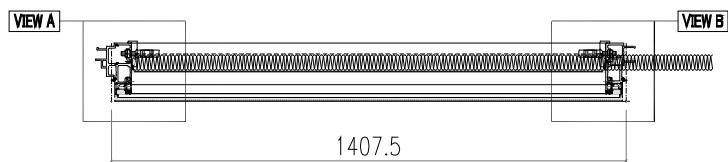
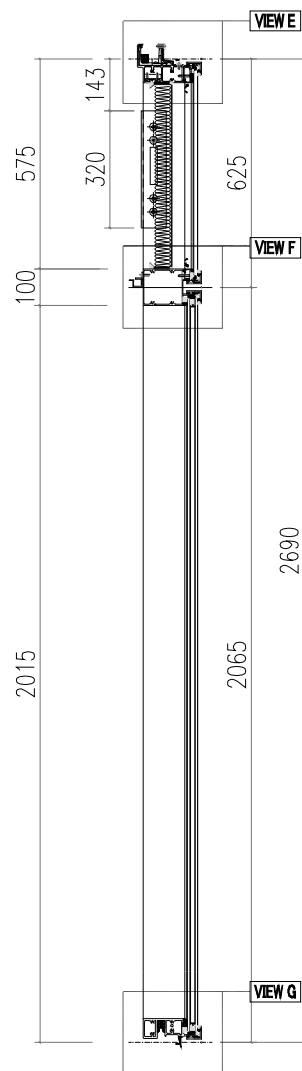
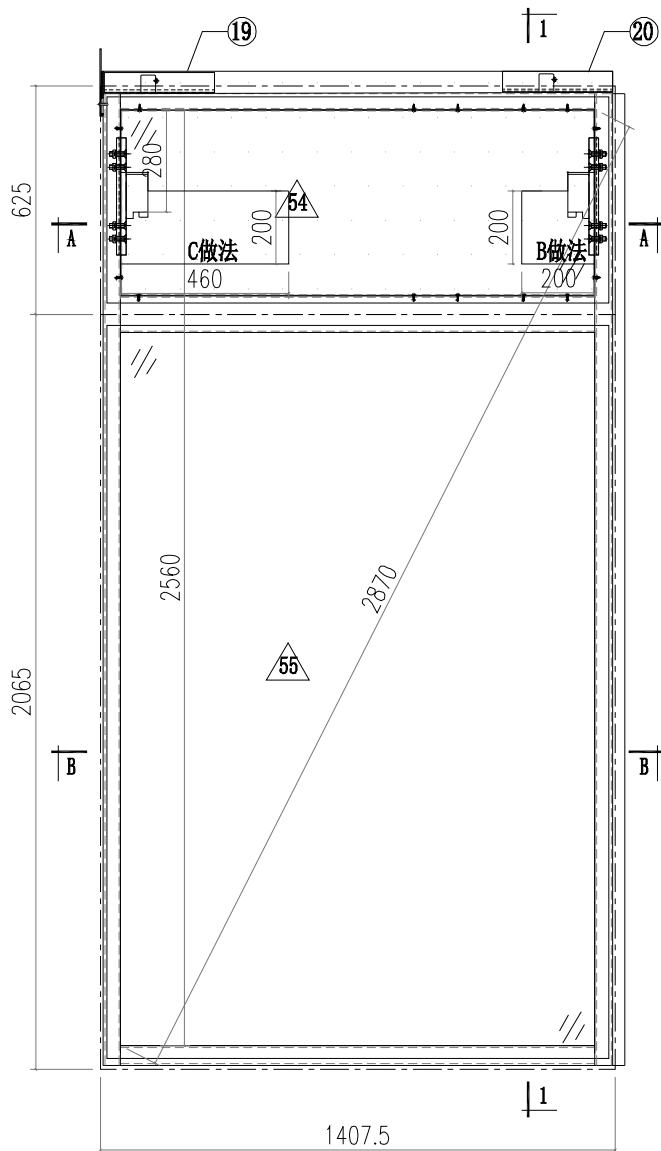

SECTION B-B

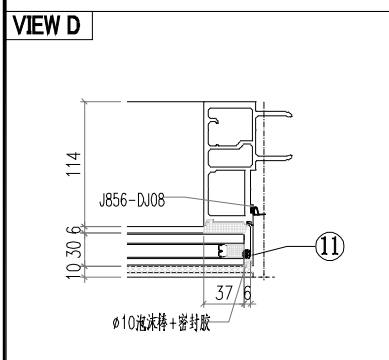
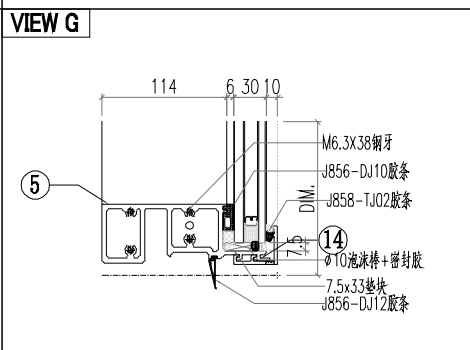
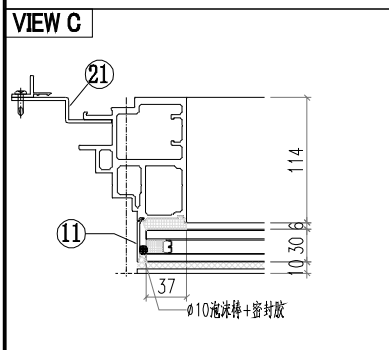
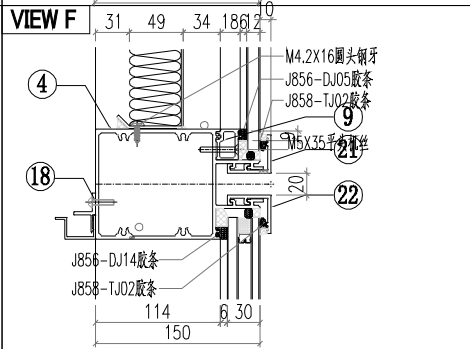
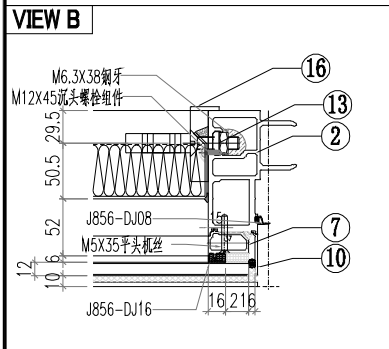
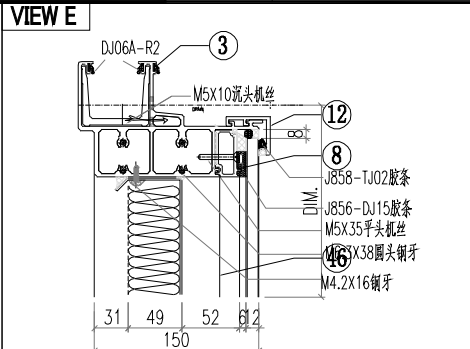
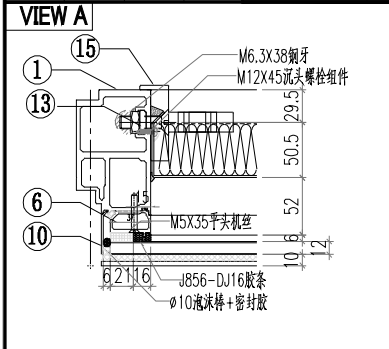

○ALUM. EXTRUSION

ITEM	FAB. DWG NO.	LENGTH (mm)	QTY
1	AM06-SU01	2657	1
2	AM01-SU02	2657	1
3	AT01-SU02-002	1428	1
4	AT03-SU01-004	1381.5	1
5	AT02-SU02-004	1381.5	1
6	X86371-T04	580.5	1
7	X86371-T03	580.5	1
8	X86374-SU01-06	1295.5	1
9	X86375-SU01-06	1295.5	1
10	AC01-T01-02/AC01-T01R-2	597	2
11	AC01-P02-02/AC01-P02R-2	2037	2
12	X86412-SU01-06	1387.5	2
13	MS01-P01	320	2
14	X86412-SK01-06	1387.5	2
15	X86372-P01	320	1
16	X86372-P02	320	1
17			
18	AJ03-SU01-06	1287.5	1
19	GS01-K02	150	1
20	GS01-K01	300	1
21	AX04-P04	1950	1
22			
23			
24			
25			
26			
27			
28			
29			
30			
31			
32			
33			
34			
35			
36			
37			
38			
39			
40			
41			
42			
43			
44			
45			

△ OTHERS (ALUM. & G.M.S. PARTS)

ITEM	FAB. DWG NO.	LENGTH (mm)	QTY
46	BP-DA06		1
	1295.5X508		
47	LB-P02		1
48			
49			
50			
51			
52			
53			
54	PT-GL04-A12		1
	1371.5X565		
55	PT-GL01-A12		1
	1371.5X2005		

 美特鋁質有限公司 MIDI Aluminium Fabricator Ltd.		工程號 J856 地盤 天榮站 图纸名称 单元组装图 材料 -	類別 制圖 李傳鵬 復核 練松文 批准 林仁安	物料號 M1 圖號 CW-413 數量 - 單件重量 - (KG)
修改日期 採用工廠 地盤 ✓ 材料颜色 -UCT542919XL-3				

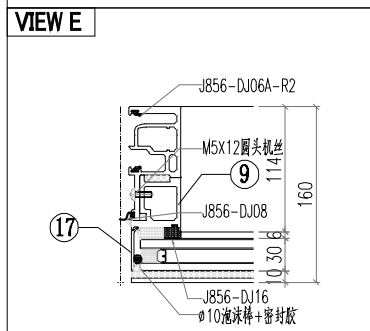
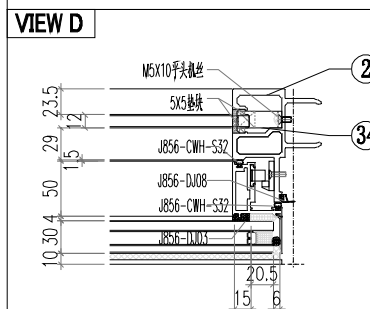
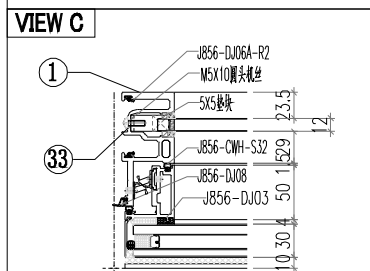
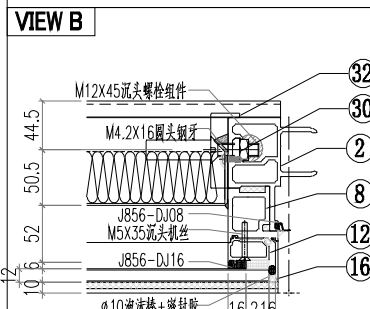
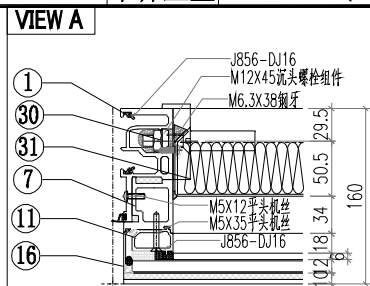
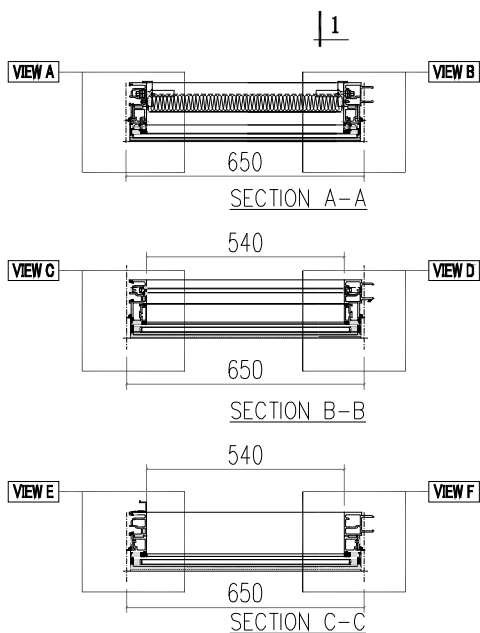
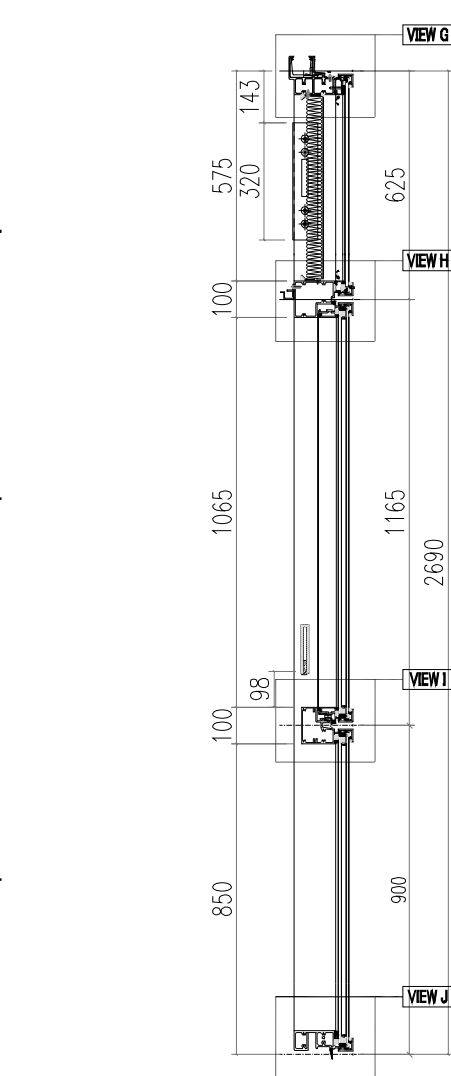
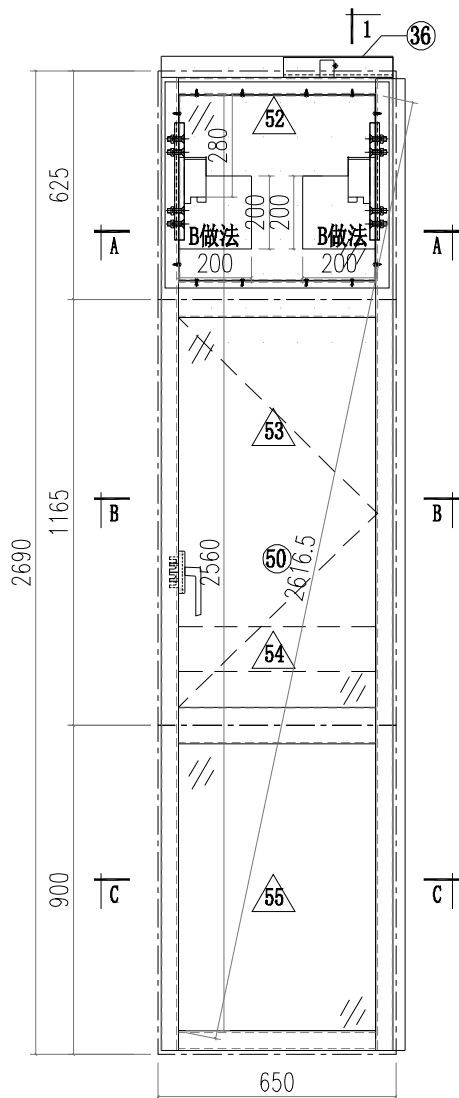

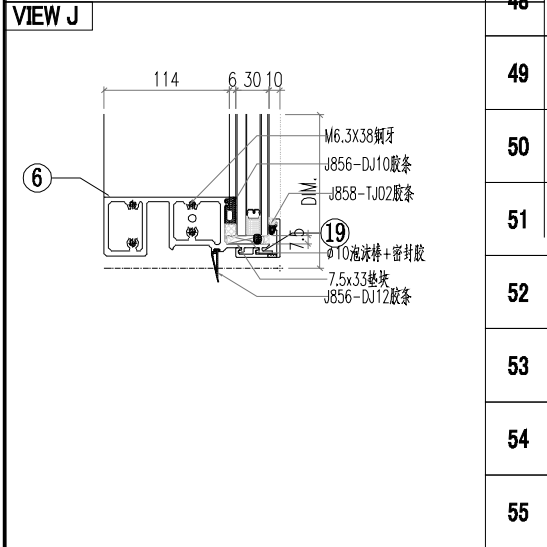
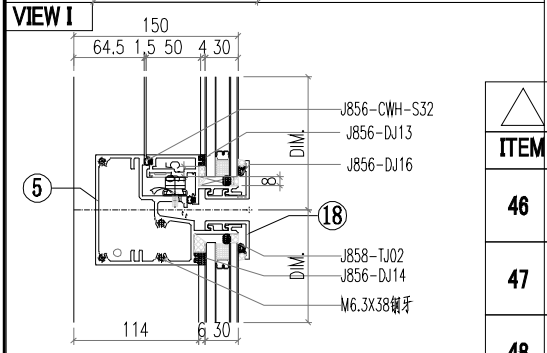
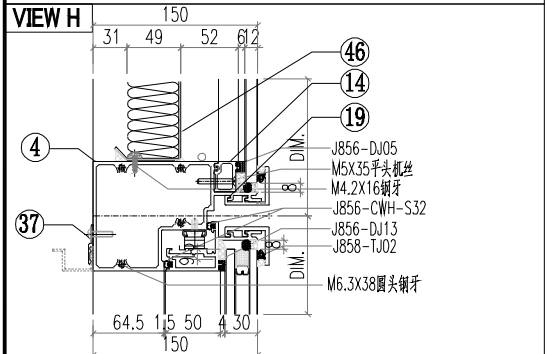
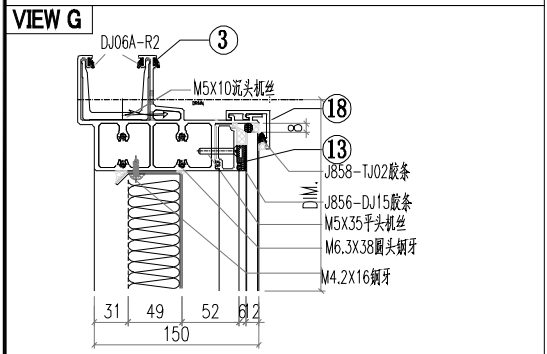
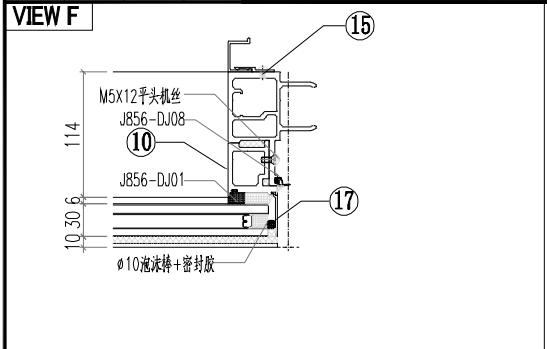

ALUM. EXTRUSION			
ITEM	FAB. DWG NO.	LENGTH (mm)	QTY
1	X86365-SU04	2657	1
2	X86364-SU03	2657	1
3	AT01-SU01-001	635	1
4	AT04-SU03-001	630	1
5	AT05-SU03-001	630	1
6	AT02-SU01-001	624	1
7	AD06-T07	580	1
8	AD06-T08	580	1
9	AD06-P01	862	1
10	AD06-P02	862	1
11	X86371-T03	580.5	1
12	X86371-T04	580.5	1
13	X86374-SU01-01	538	1
14	X86375-SU01-01	538	1
15	AJ04-P01	1950	1
16	AC01-T01-02/AC01-T01R-2	597	2
17	AC01-P02-01/AC01-P02R-1	872	2
18	X86412-SU01-01	630	2
19	X86412-SK01-01	630	2
20			
21			
22			
23			
24			
25			
26			
27			
28			
29			
30	MS01-P01	320	2
31	X86372-P01	320	1
32	X86372-P02	320	1
33	J60*38-001	15	1
34	J60*38-002	15	1
35			
36	GS01-K01	300	1
37	AJ03-SU01-01	530	1
38			
39			
40			
41			
42			
43			
44			
45			

OTHERS (ALUM. & G.M.S. PARTS)			
ITEM	FAB. DWG NO.	LENGTH (mm)	QTY
46	BP-DA01		1
47	538X508		
48			
49			
50	CE-001		1
51			
52	PT-GL04-A08 614X565		1
53	PT-GL01-B01 614X1105		1
54	PT-GL05-A01 570X122		1
55	PT-GL01-A01 614X840		1

 美特鋁質有限公司 MIDI Aluminium Fabricator Ltd.		工程號 J856 地盤 天榮站	類別 制圖 李傳鵬 復核 練松文 批准 林仁安	物料號 M1 2022-11-26 2022-11-27 2022-11-28	圖號 CW-414 數量 - 單件重量 - (KG)
修改 日期	採用工廠 材料顏色 -UCT542919XL-3	地盤 <input checked="" type="checkbox"/>	图纸名称 单元组装图 材料 -		

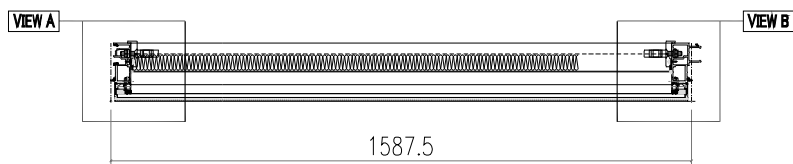
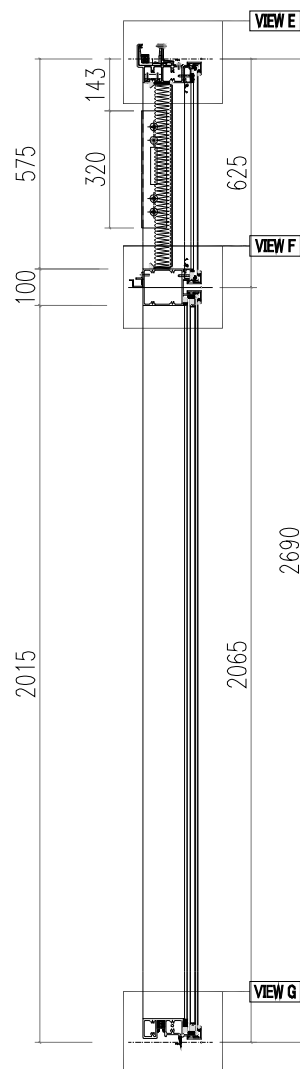
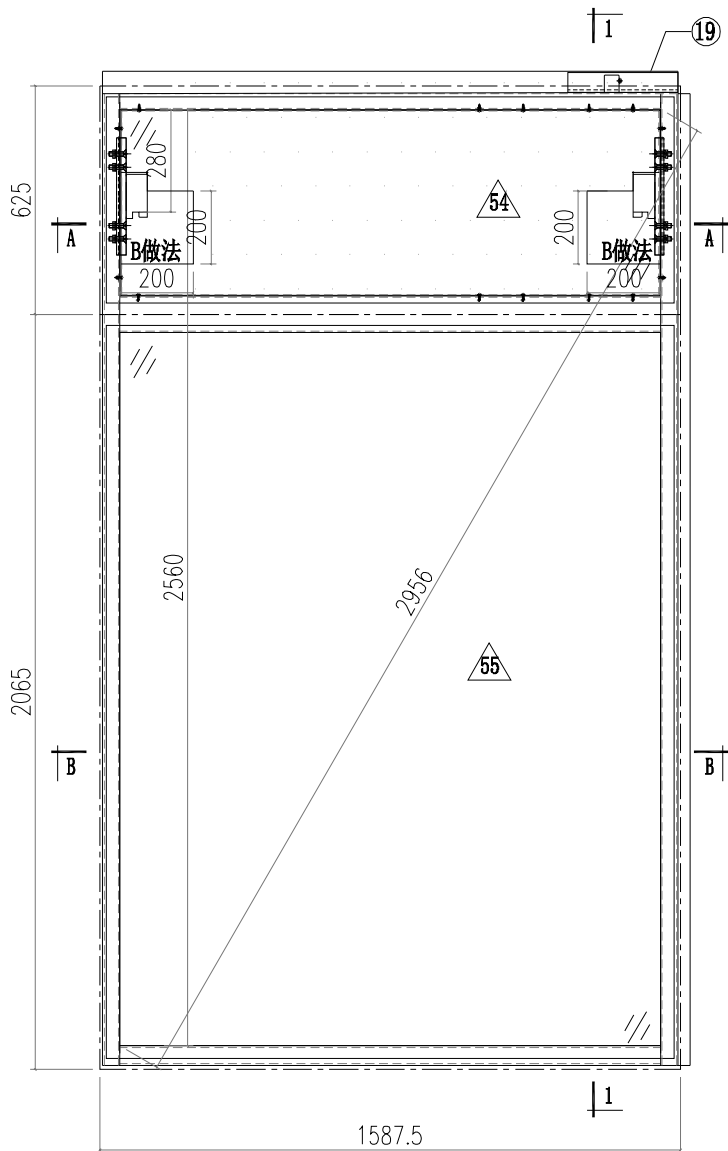

SECTION A-A
1477.5

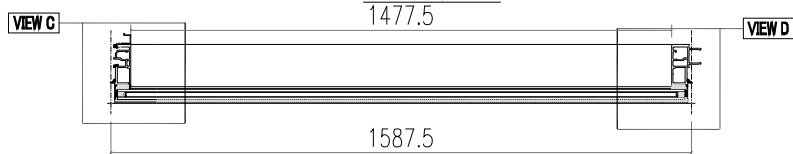

SECTION B-B

修改 日期

採用工廠 地盤 材料颜色 -UCT542919XL-3

图纸名称 单元组装图
材料 -

批准 林仁安 2022-11-28

數量 -
單件重量 - (KG)

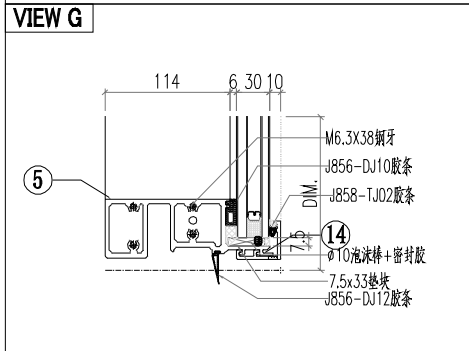
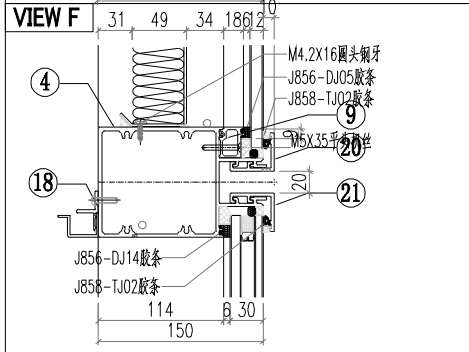
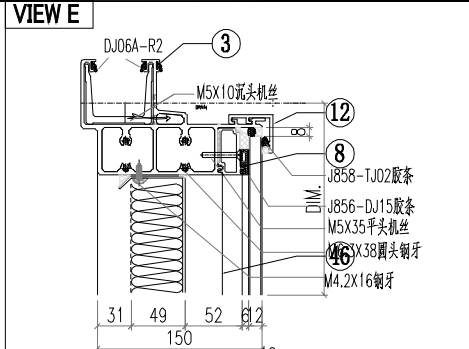
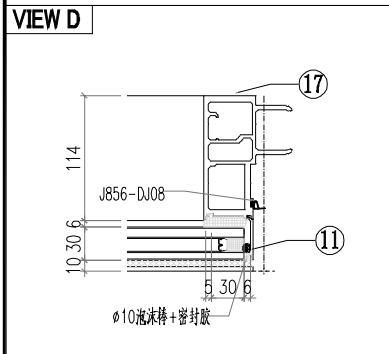
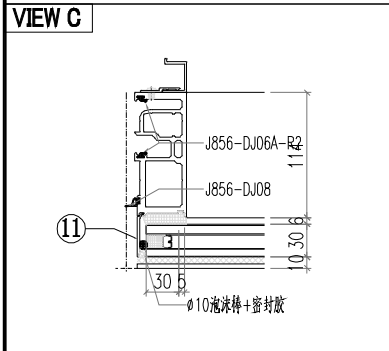
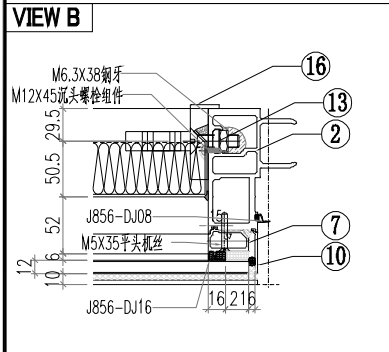
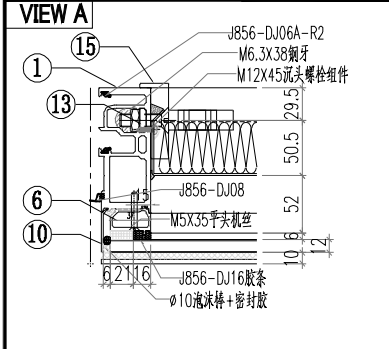

△ OTHERS (ALUM. & G.M.S. PARTS)

ITEM	FAB. DWG NO.	LENGTH (mm)	QTY
46	BP-DA03		1
	1475.5X508		
47			
48			
49			
50			
51			
52			
53			
54	PT-GL04-A09		1
	1551.5X565		
55	PT-GL01-A09		1
	1551.5X2005		

○ ALUM. EXTRUSION

ITEM	FAB. DWG NO.	LENGTH (mm)	QTY
1	AM02-SU02	2657	1
2	AM01-SU02	2657	1
3	AT01-SU01-007	1572.5	1
4	AT03-SU01-005	1561.5	1
5	AT02-SU02-005	1561.5	1
6	X86371-T04	580.5	1
7	X86371-T03	580.5	1
8	X86374-SU01-03	1475.5	1
9	X86375-SU01-03	1475.5	1
10	AC01-T01-02/AC01-T01R-2	597	2
11	AC01-P02-02/AC01-P02R-2	2037	2
12	X86412-SU01-03	1567.5	2
13	MS01-P01	320	2
14	X86412-SK01-03	1567.5	2
15	X86372-P01	320	1
16	X86372-P02	320	1
17	AJ04-P02	1950	1
18	AJ03-SU01-03	1467.5	1
19	GS01-K01	300	1
20			
21			
22			
23			
24			
25			
26			
27			
28			
29			
30			
31			
32			
33			
34			
35			
36			
37			
38			
39			
40			
41			
42			
43			
44			
45			

 美特鋁質有限公司 MIDI Aluminium Fabricator Ltd.			工程號 J856 地盘 天榮站	類別 制圖 李傳鵬 復核 練松文 批准 林仁安	物料號 M1 2022-11-26 2022-11-27 2022-11-28	圖號 CW-415 數量 - 單件重量 - (KG)	
修改 日期	採用工廠 材料颜色 -UCT542919XL-3	地盤 <input checked="" type="checkbox"/>	图纸名称 单元组装图 材料 -				

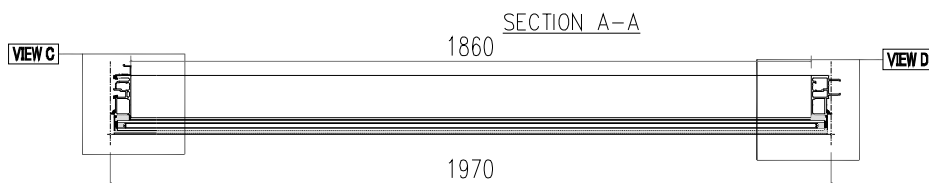
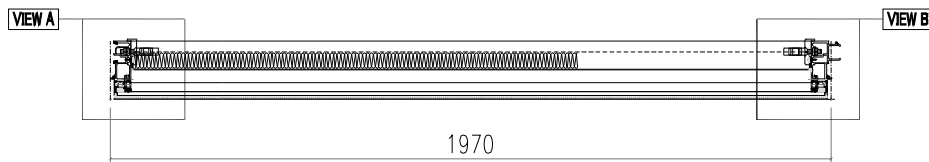
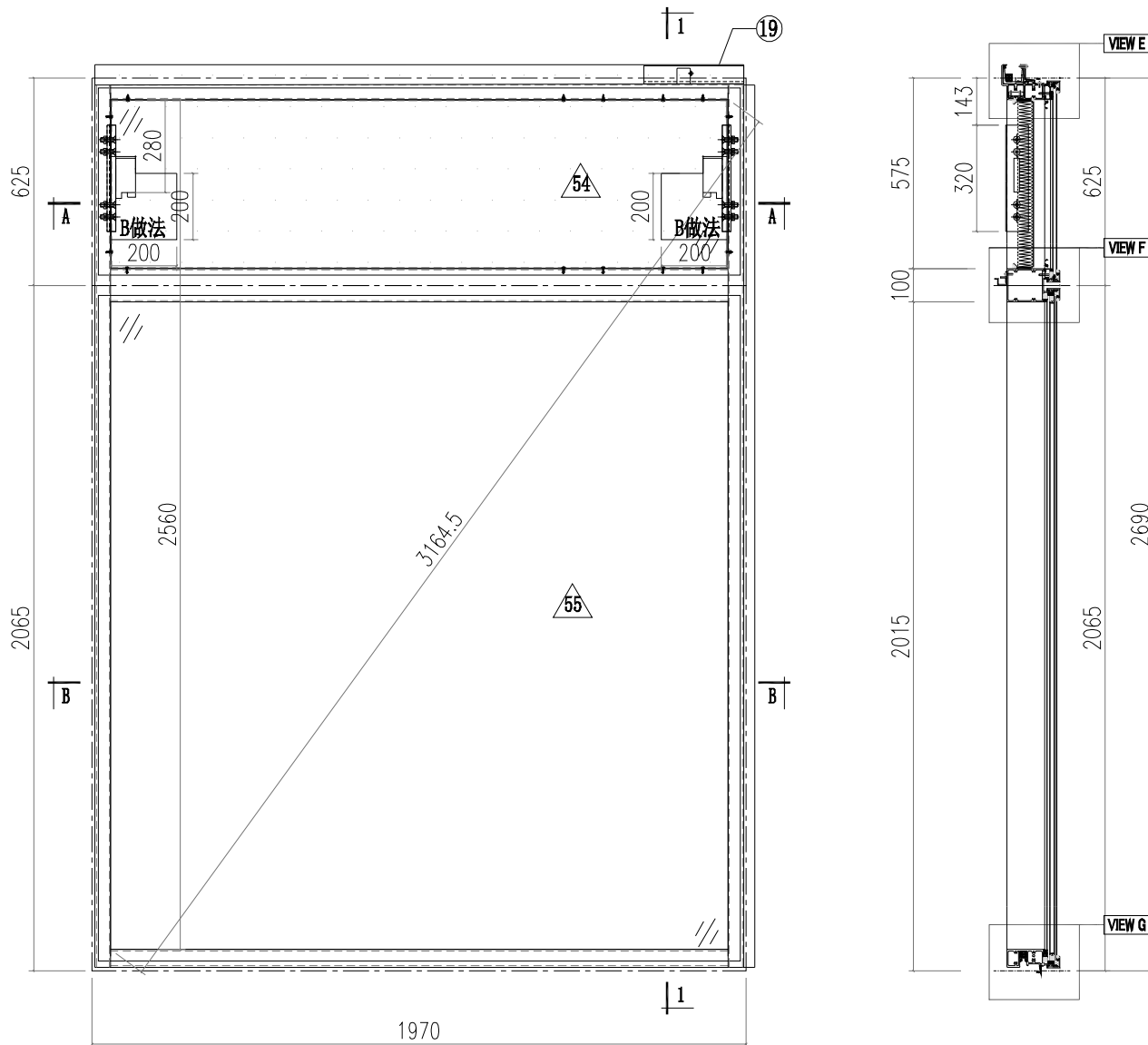

SECTION B-B

 美特鋁質有限公司 MIDI Aluminium Fabricator Ltd.			工程號 J856 地盤 天榮站	類別 制圖 李傳鵬 復核 練松文 批准 林仁安	物料號 M1 2022-11-26 2022-11-27 2022-11-28	圖號 CW-415 數量 - 單件重量 - (KG)
修改日期 採用工廠 地盤 ✓ 材料顏色 - UCT542919XL-3	图纸名称 单元组装图 材料 -					

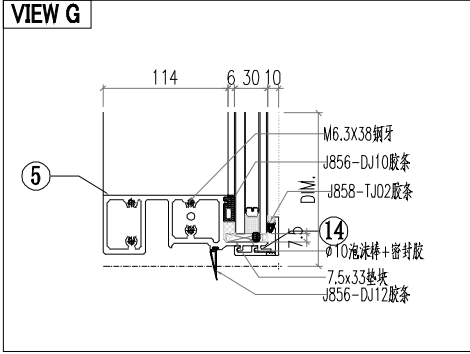
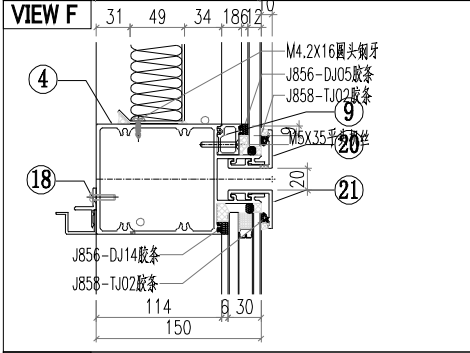
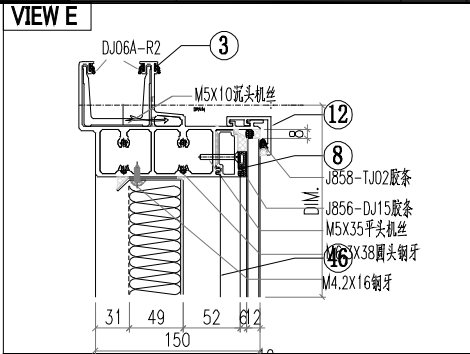
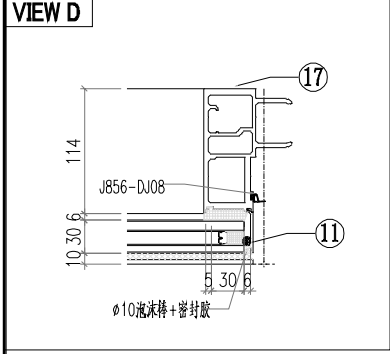
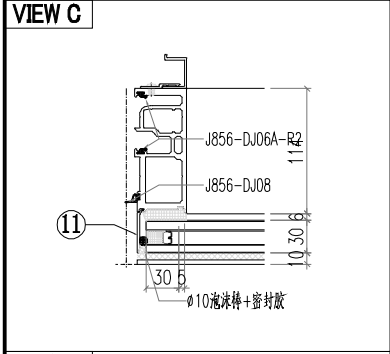
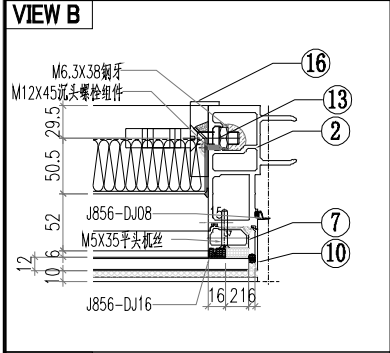
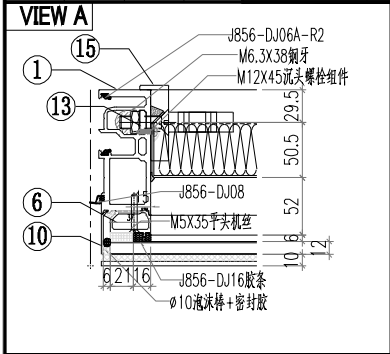

△ OTHERS (ALUM. & G.M.S. PARTS)			
ITEM	FAB. DWG NO.	LENGTH (mm)	QTY
46	BP-DA07		1
	1858X508		
47			
48			
49			
50			
51			
52			
53			
54	PT-GL04-A13		1
	1934X565		
55	PT-GL01-A13		1
	1934X2005		

○ ALUM. EXTRUSION			
ITEM	FAB. DWG NO.	LENGTH (mm)	QTY
1	AM02-SU02	2657	1
2	AM01-SU02	2657	1
3	AT01-SU01-008	1955	1
4	AT03-SU01-006	1944	1
5	AT02-SU02-006	1944	1
6	X86371-T04	580.5	1
7	X86371-T03	580.5	1
8	X86374-SU01-07	1858	1
9	X86375-SU01-07	1858	1
10	AC01-T01-02/AC01-T01R-2	597	2
11	AC01-P02-02/AC01-P02R-2	2037	2
12	X86412-SU01-07	1950	2
13	MS01-P01	320	2
14	X86412-SK01-07	1950	2
15	X86372-P01	320	1
16	X86372-P02	320	1
17	AJ04-P02	1950	1
18	AJ03-SU01-07	1850	1
19	GS01-K01	300	1
20			
21			
22			
23			
24			
25			
26			
27			
28			
29			
30			
31			
32			
33			
34			
35			
36			
37			
38			
39			
40			
41			
42			
43			
44			
45			

 美特鋁質有限公司 MIDI Aluminium Fabricator Ltd.		工程號 J856 地盘 天榮站 图纸名称 单元组装图 材料 -	類別 制圖 李傳鵬 復核 練松文 批准 林仁安	物料號 M1 圖號 CW-416 數量 - 單件重量 - (KG)
修改 日期	採用工廠 材料颜色 -UCT542919XL-3	地盤 <input checked="" type="checkbox"/>		

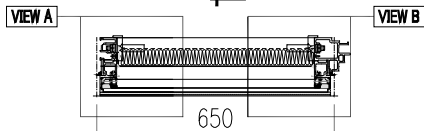
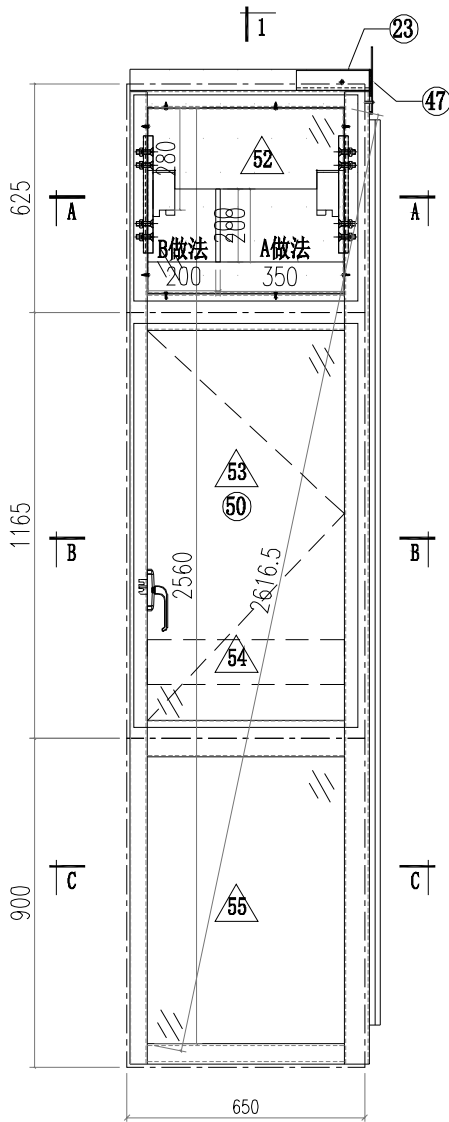

SECTION A-A

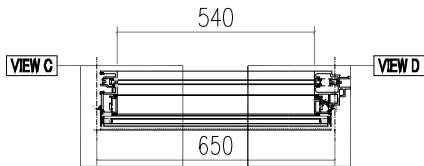

SECTION B-B

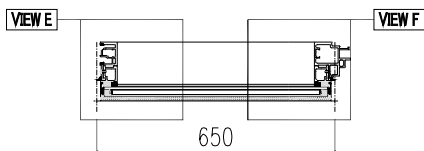

SECTION C-C

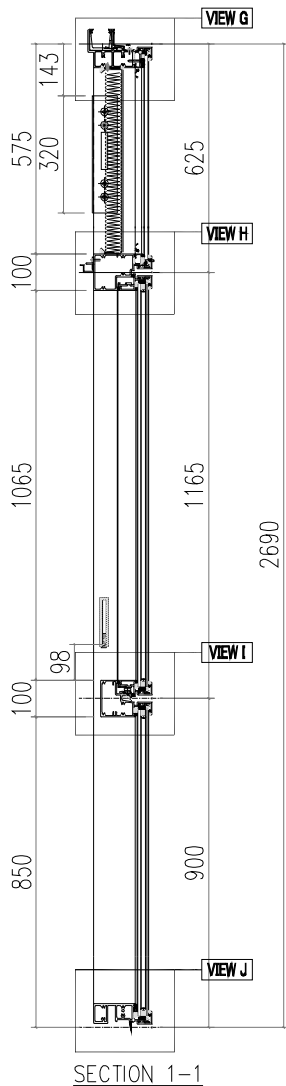

SECTION 1-1

VIEW A

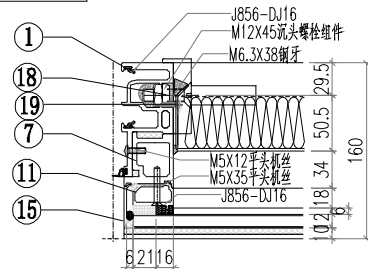

VIEW B

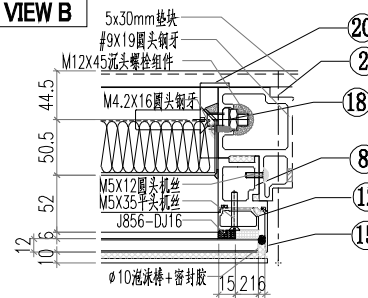

VIEW C

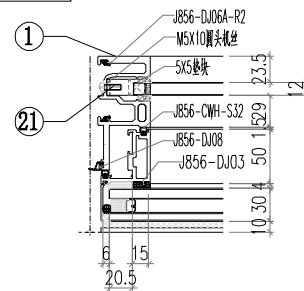

VIEW D

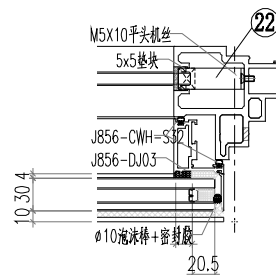

VIEW E

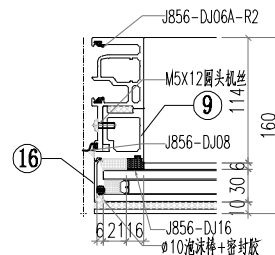

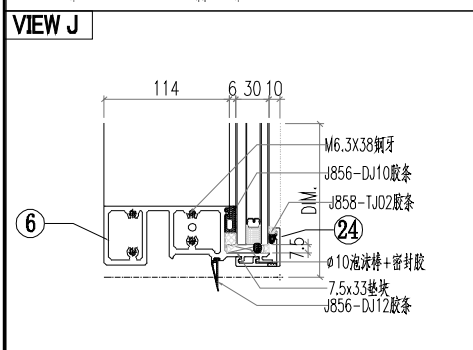
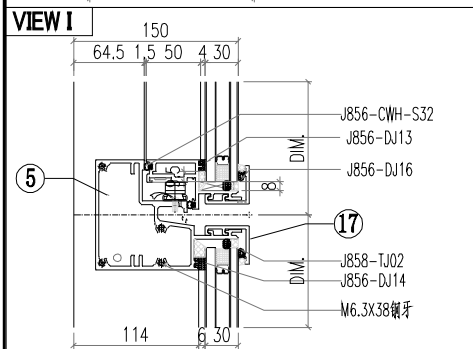
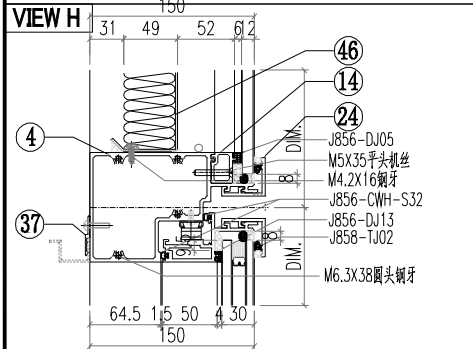
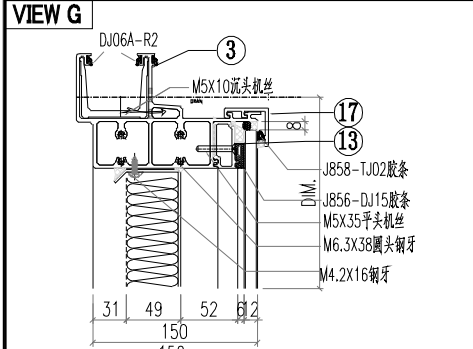
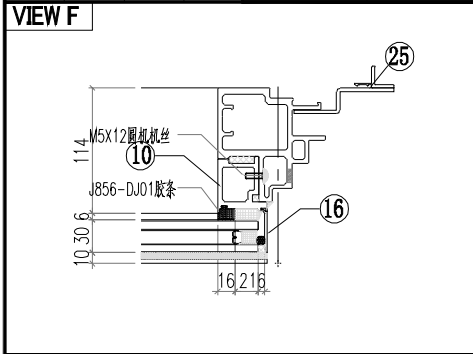

ALUM. EXTRUSION

ITEM	FAB. DWG NO.	LENGTH (mm)	QTY
1	X86365-SU04	2657	1
2	X86367-SU04	2657	1
3	AT01-SU03-001	670.5	1
4	AT04-SU03-001	630	1
5	AT05-SU03-001	630	1
6	AT02-SU01-001	624	1
7	AD06-T07	580	1
8	AD06-T08	580	1
9	AD06-P01	862	1
10	AD06-P02	862	1
11	X86371-T03	580.5	1
12	X86371-T04	580.5	1
13	X86374-SU01-01	538	1
14	X86375-SU01-01	538	1
15	AC01-T01-02/AC01-T01R-2	597	2
16	AC01-P02-01/AC01-P02R-1	872	2
17	X86412-SU01-01	630	2
18	MS01-P01	320	2
19	X86372-P01	320	1
20	X86372-P02	320	1
21	J60*38-001	15	1
22	J60*38-003	15	1
23	GS01-K02	150	1
24	X86412-SK01-01	630	2
25	AX04-P03	1950	1
26			
27			
28			
29			
30			

OTHERS (ALUM. & G.M.S. PARTS)

ITEM	FAB. DWG NO.	LENGTH (mm)	QTY
31			
32			
33			
34			
35			
36			
37	AJ03-SU01-1	530	1
38			
39			
40			
41			
42			
43			
44			
45			
46	BP-DA01		1
47	538X508		1
48	LB-P01		1
49			
50	CE-001		1
51			
52	PT-GL04-A08		1
53	614X565		1
54	PT-GL01-B01		1
55	614X1105		1
56	PT-GL05-A01		1
57	570X122		1
58	PT-GL01-A01		1
59	614X840		1

 美特鋁質有限公司 MIDI Aluminium Fabricator Ltd.		工程號 J856 地盘 天榮站	類別 制圖 李傳鵬 復核 練松文 批准 林仁安	物料號 M1 圖號 CW-417 數量 - 單件重量 - (KG)
修改 日期	採用工廠 材料颜色 -UCT542919XL-3	图纸名称 单元组装图 材料 -		

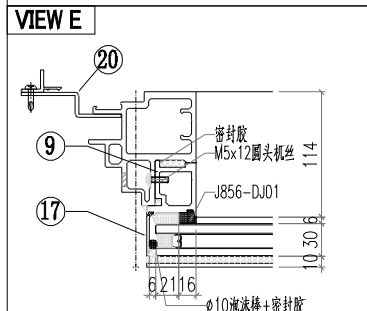
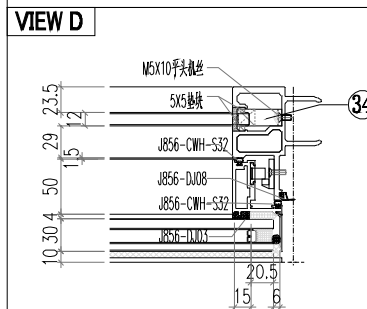
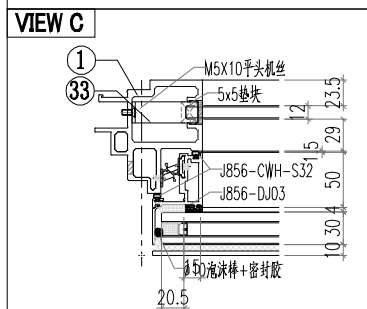
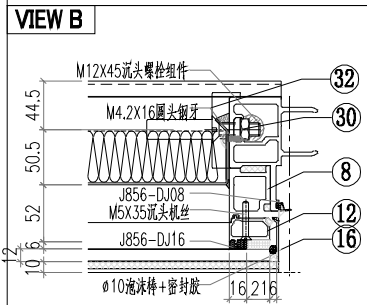
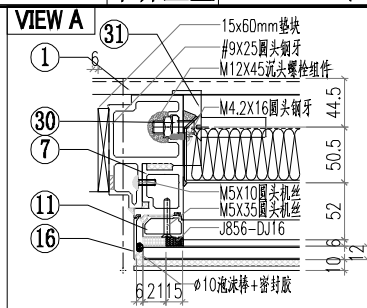
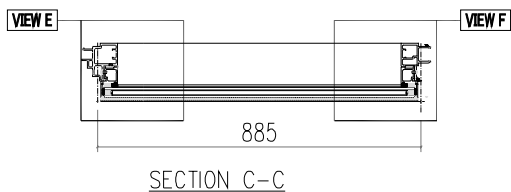
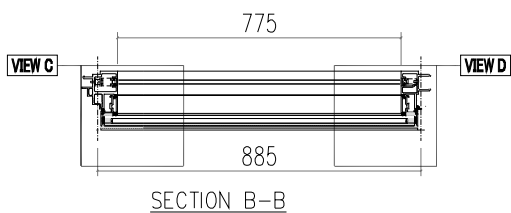
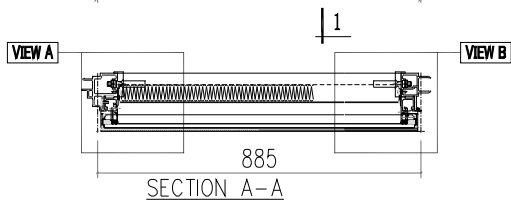
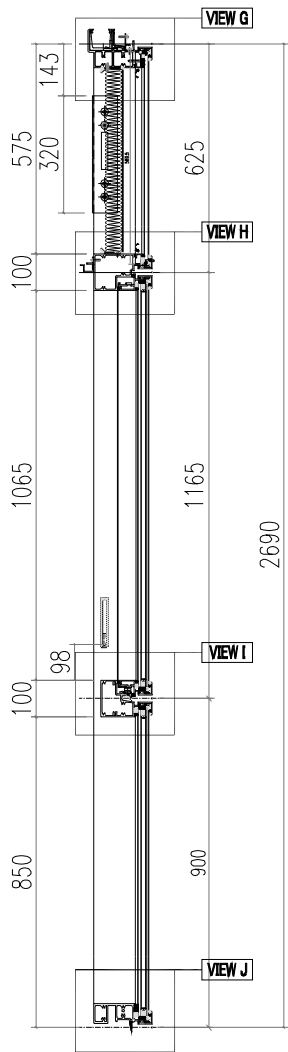
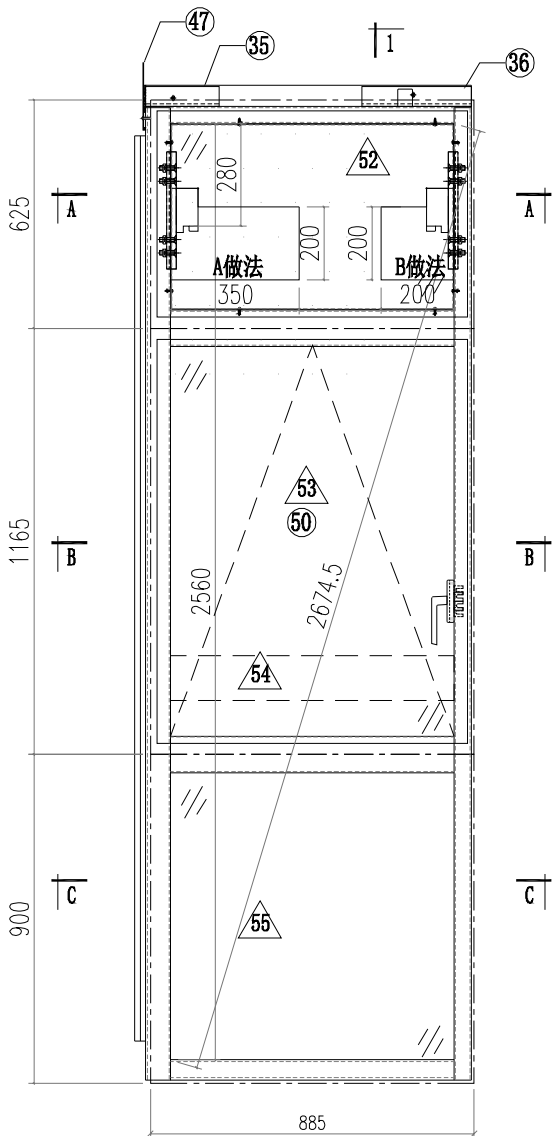

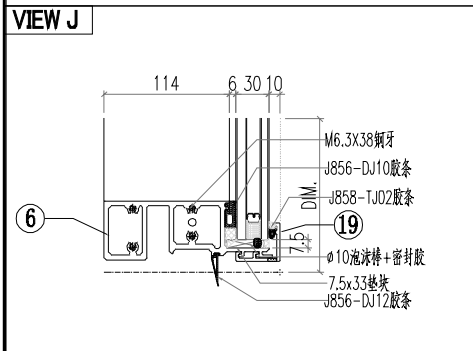
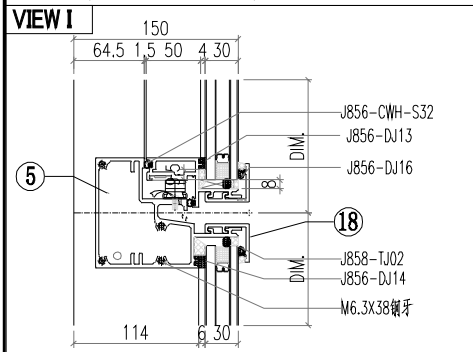
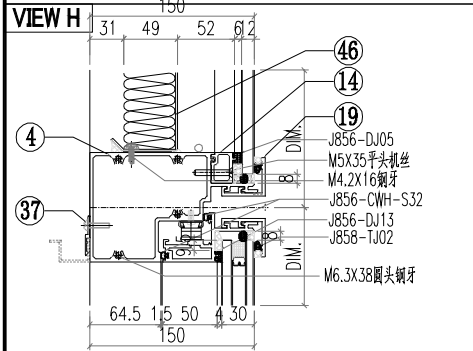
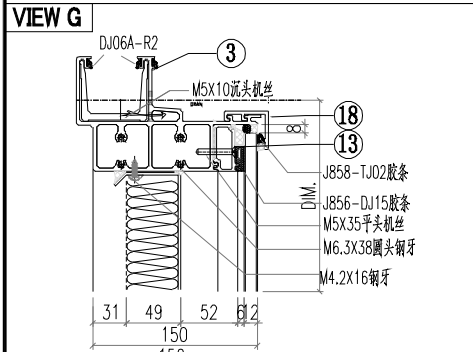
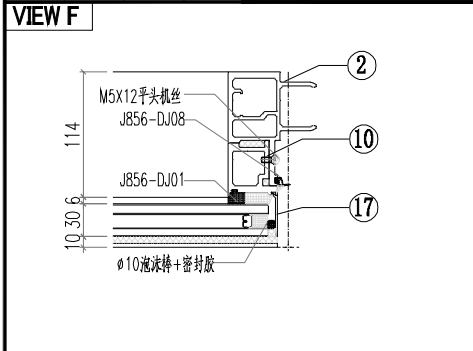

ALUM. EXTRUSION

ITEM	FAB. DWG NO.	LENGTH (mm)	QTY
1	X86367-SU03	2657	1
2	X86364-SU02	2657	1
3	AT01-SU02-003	905.5	1
4	AT04-SU02-002	865	1
5	AT05-SU02-002	865	1
6	AT02-SU01-002	859	1
7	AD06-T07	580	1
8	AD06-T08	580	1
9	AD06-P01	862	1
10	AD06-P02	862	1
11	X86371-T03	580.5	1
12	X86371-T04	580.5	1
13	X86374-SU01-04	773	1
14	X86375-SU01-04	773	1
15			
16	AC01-T01-02/AC01-T01R-2	597	2
17	AC01-P02-01/AC01-P02R-1	872	2
18	X86412-SU01-04	865	2
19	X86412-SK01-04	865	2
20	AX04-P04	1950	1
21			
22			
23			
24			
25			
26			
27			
28			
29			
30	MS01-P01	320	2
31	X86372-P01	320	1
32	X86372-P02	320	1
33	J60*38-003	15	1
34	J60*38-002	15	1
35	GS01-K02	150	1
36	GS01-K01	300	1
37	AJ03-SU01-4	765	1
38			
39			
40	CE-011		
41			
42			
43			
44			
45			

OTHERS (ALUM. & G.M.S. PARTS)

ITEM	FAB. DWG NO.	LENGTH (mm)	QTY
46	BP-DA04		1
	773X508		
47	LB-P02		1
48			
49			
50			
51			
52	PT-GL04-A10		1
	849X565		
53	PT-GL01-B06		1
	849X1105		
54	PT-GL05-A02		1
	805X122		
55	PT-GL01-A10		1
	849X840		

 美特鋁質有限公司 MIDI Aluminium Fabricator Ltd.		工程號 J856 地盘 天榮站	類別 制圖 李傳鵬 復核 練松文 批准 林仁安	物料號 M1 2022-11-26 2022-11-27 2022-11-28	圖號 CW-418 數量 - 單件重量 - (KG)
修改 日期	採用工廠 材料颜色 -UCT542919XL-3	图纸名称 单元组装图 材料 -			

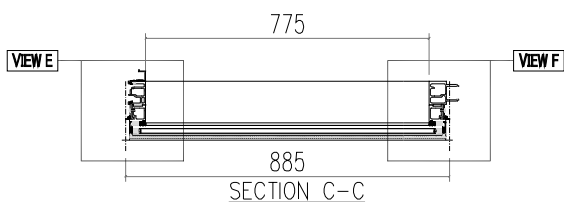
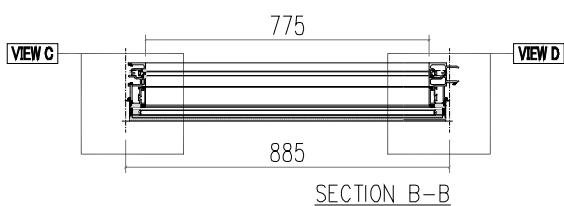
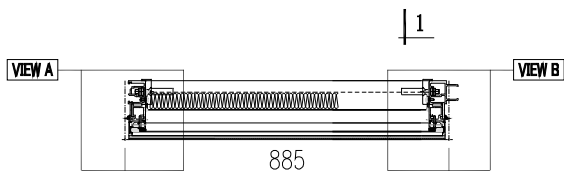
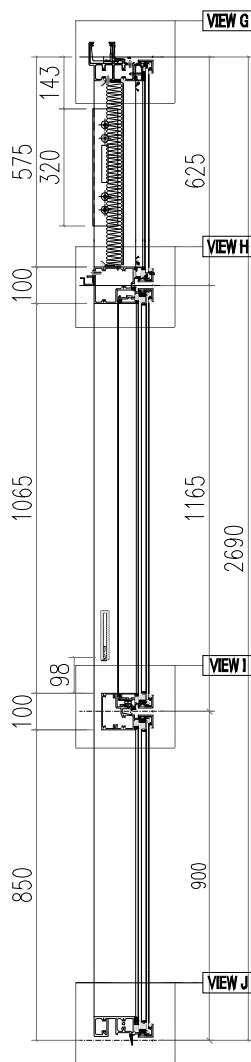
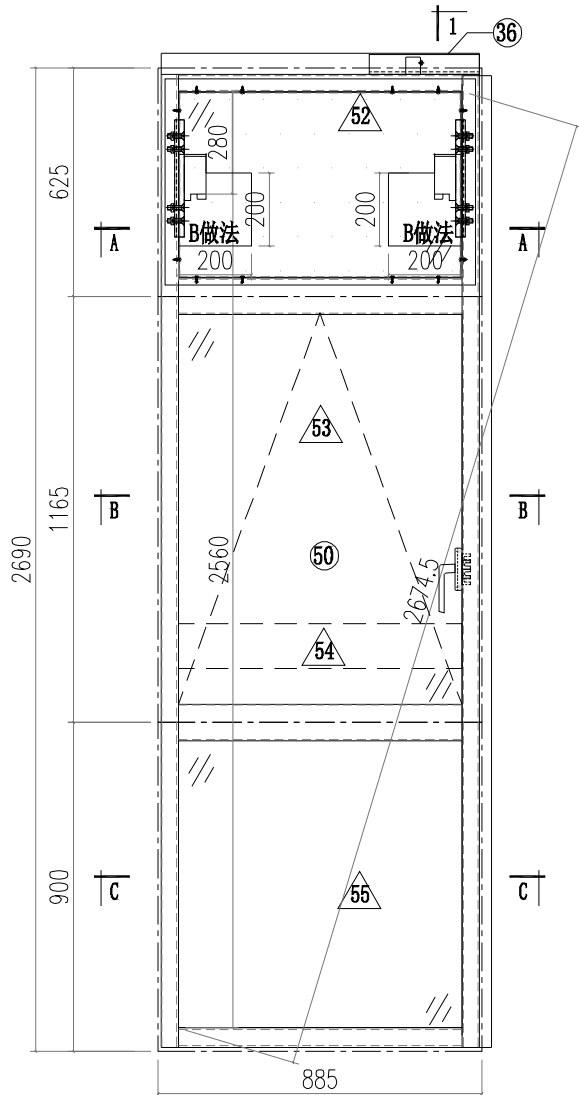

VIEW A

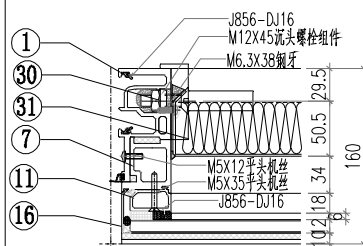

VIEW B

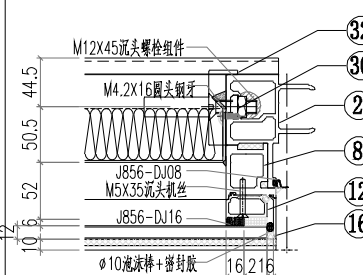

VIEW C

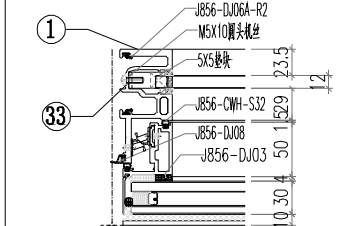

VIEW D

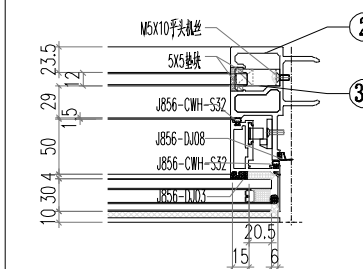

VIEW E

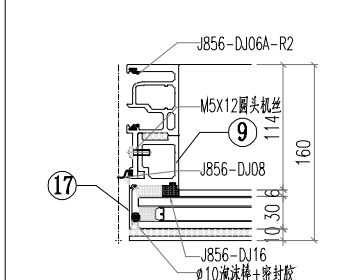

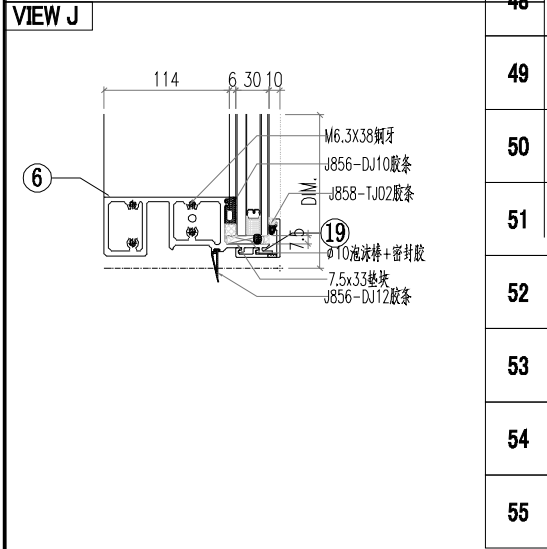
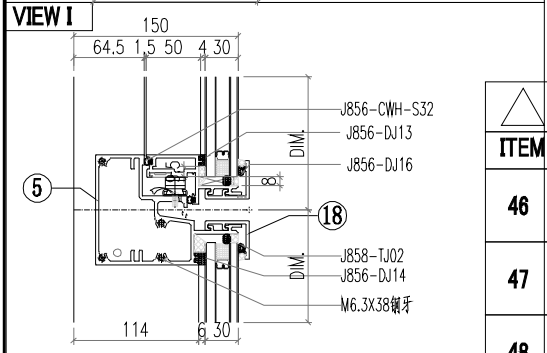
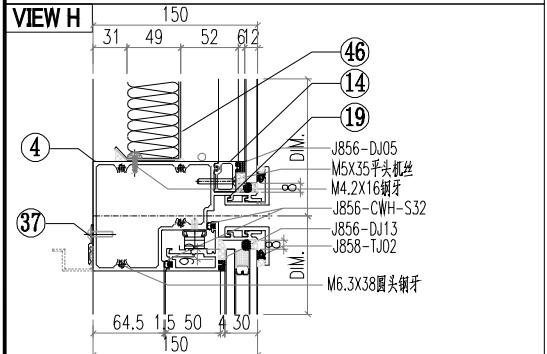
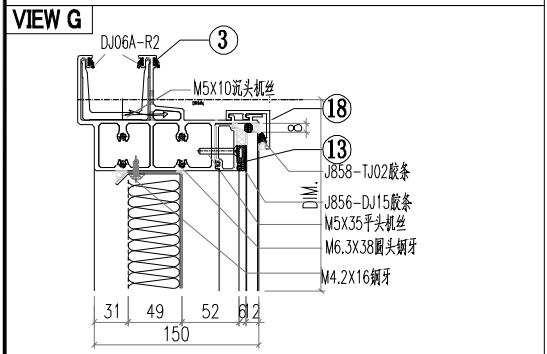
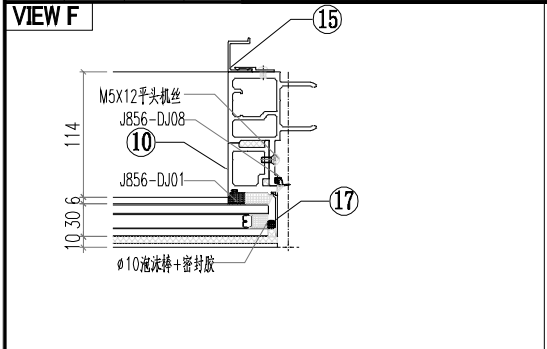

ALUM. EXTRUSION			
ITEM	FAB. DWG NO.	LENGTH (mm)	QTY
1	X86365-SU03	2657	1
2	X86364-SU04	2657	1
3	AT01-SU01-004	870	1
4	AT04-SU02-002	865	1
5	AT05-SU02-002	865	1
6	AT02-SU01-002	859	1
7	AD06-T07	580	1
8	AD06-T08	580	1
9	AD06-P01	862	1
10	AD06-P02	862	1
11	X86371-T03	580.5	1
12	X86371-T04	580.5	1
13	X86374-SU01-04	773	1
14	X86375-SU01-04	773	1
15	AJ04-P01	1950	1
16	AC01-T01-02/AC01-T01R-2	597	2
17	AC01-P02-01/AC01-P02R-1	872	2
18	X86412-SU01-04	865	2
19	X86412-SK01-04	865	2
20			
21			
22			
23			
24			
25			
26			
27			
28			
29			
OTHERS (ALUM. & G.M.S. PARTS)			
ITEM	FAB. DWG NO.	LENGTH (mm)	QTY
30	MS01-P01	320	2
31	X86372-P01	320	1
32	X86372-P02	320	1
33	J60*38-001	15	1
34	J60*38-002	15	1
35			
36	GS01-K01	300	1
37	AJ03-SU01-04	765	1
38			
39			
40			
41			
42			
43			
44			
45			
46	BP-DA04		1
47	773X508		
48			
49			
50	CE-011		1
51			
52	PT-GL04-A10		1
	849X565		
53	PT-GL01-B06		1
	849X1105		
54	PT-GL05-A02		1
	805X122		
55	PT-GL01-A10		1
	849X840		

 美特鋁質有限公司 MIDI Aluminium Fabricator Ltd.			工程號 J856 地盘 天榮站	類別 制圖 李傳鵬 復核 練松文 批准 林仁安	物料號 M1 2022-11-26 2022-11-27 2022-11-28	圖號 CW-419 數量 - 單件重量 - (KG)
修改 日期	採用工廠 材料颜色 -UCT542919XL-3	地盘 <input checked="" type="checkbox"/>	图纸名称 单元组装图 材料 -			

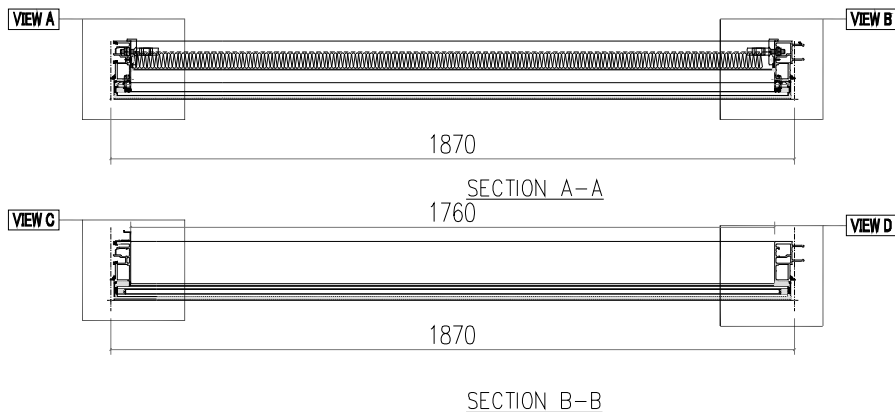
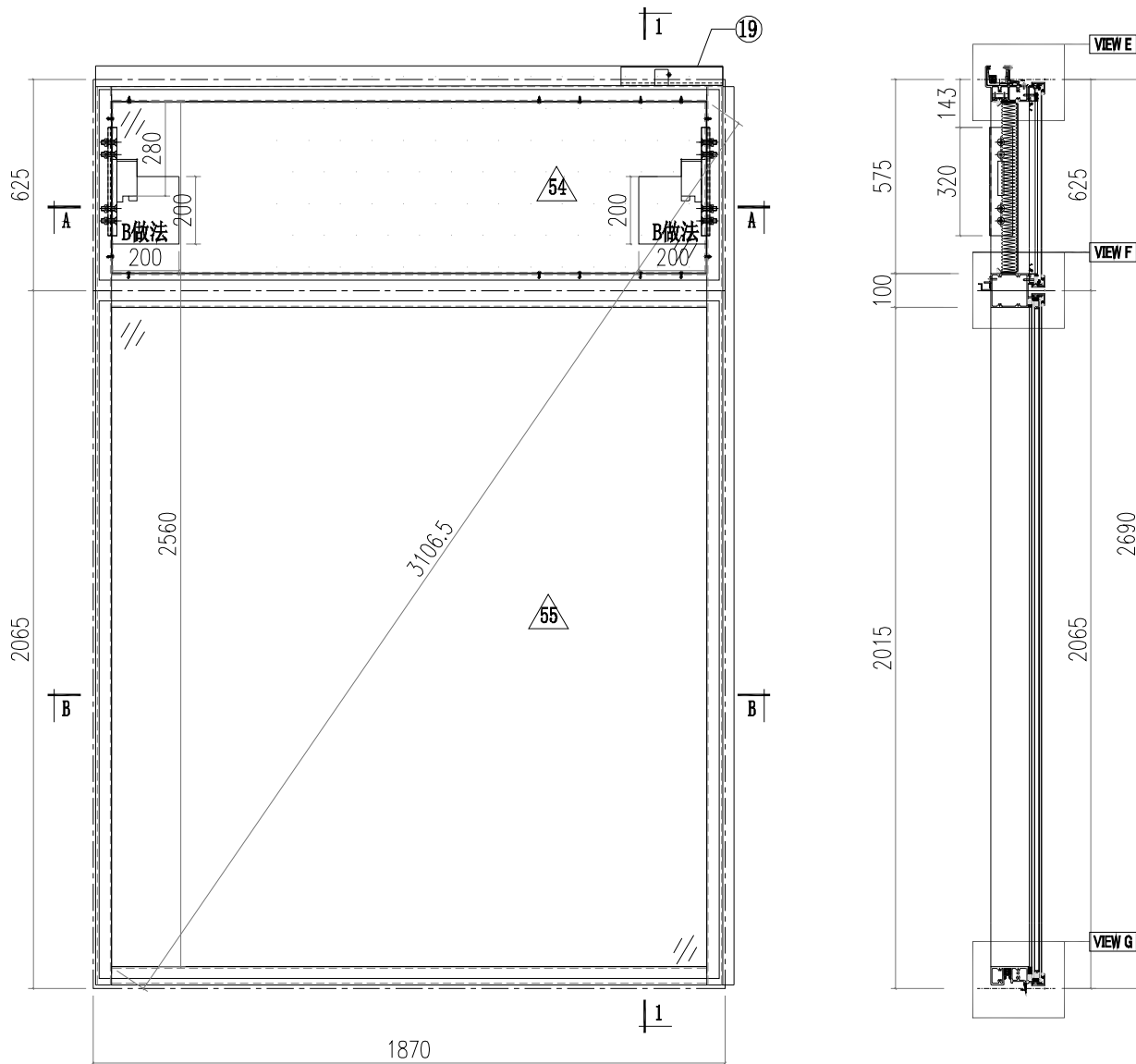

 美特鋁質有限公司 MIDI Aluminium Fabricator Ltd.			工程號 J856 地盤 天榮站	類別 制圖 李傳鵬 復核 練松文 批准 林仁安	物料號 M1 圖號 CW-419
修改 日期	採用工廠 材料顏色 -UCT542919XL-3	地盤 ✓ 图纸名称 单元组装图 材料 -	李傳鵬 2022-11-26 練松文 2022-11-27 林仁安 2022-11-28	數量 - 單件重量 - (KG)	

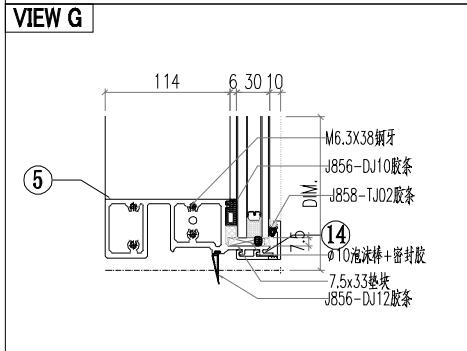
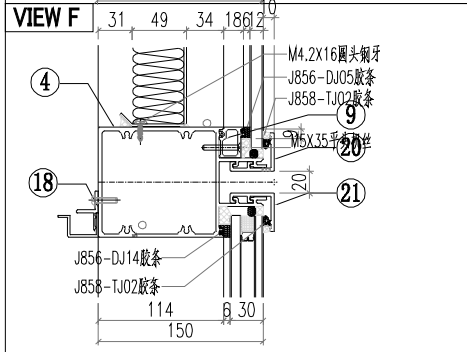
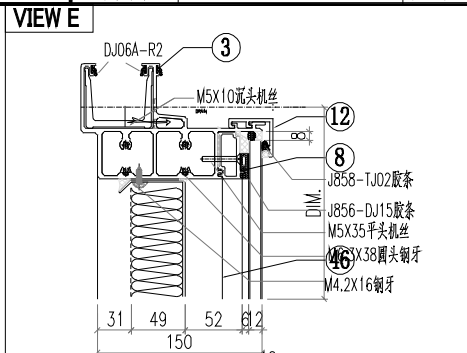
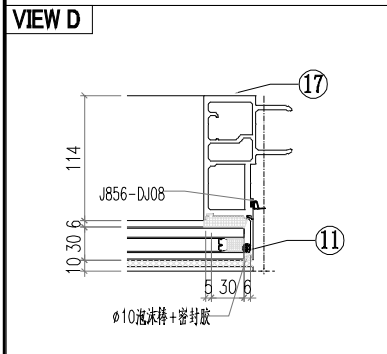
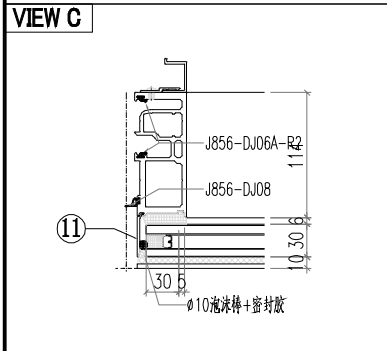
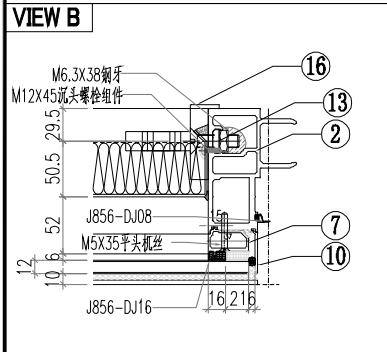
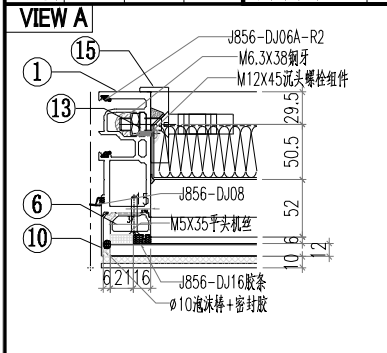

△ OTHERS (ALUM. & G.M.S. PARTS)			
ITEM	FAB. DWG NO.	LENGTH (mm)	QTY
46	BP-DA02		1
	1758X508		
47			
48			
49			
50			
51			
52			
53			
54	PT-GL04-A08A		1
	1834X565		
55	PT-GL01-A08		1
	1834X2005		

○ ALUM. EXTRUSION			
ITEM	FAB. DWG NO.	LENGTH (mm)	QTY
1	AM02-SU02	2657	1
2	AM01-SU02	2657	1
3	AT01-SU01-002	1855	1
4	AT03-SU01-001	1844	1
5	AT02-SU02-001	1844	1
6	X86371-T04	580.5	1
7	X86371-T03	580.5	1
8	X86374-SU01-02	1758	1
9	X86375-SU01-02	1758	1
10	AC01-T01-02/AC01-T01R-2	597	2
11	AC01-P02-02/AC01-P02R-2	2037	2
12	X86412-SU01-02	1850	2
13	MS01-P01	320	2
14	X86412-SK01-02	1850	2
15	X86372-P01	320	1
16	X86372-P02	320	1
17	AJ04-P02	1950	1
18	AJ03-SU01-02	1750	1
19	GS01-K01	300	1
20			
21			
22			
23			
24			
25			
26			
27			
28			
29			
30			
31			
32			
33			
34			
35			
36			
37			
38			
39			
40			
41			
42			
43			
44			
45			

 美特鋁質有限公司 MIDI Aluminium Fabricator Ltd.		工程號 J856 地盘 天榮站 图纸名称 单元组装图 材料 -	類別 制圖 李傳鵬 復核 練松文 批准 林仁安	物料號 M1 圖號 CW-420 數量 - 單件重量 - (KG)
修改 日期	採用工廠 材料颜色 -UCT542919XL-3	地盤 <input checked="" type="checkbox"/>		

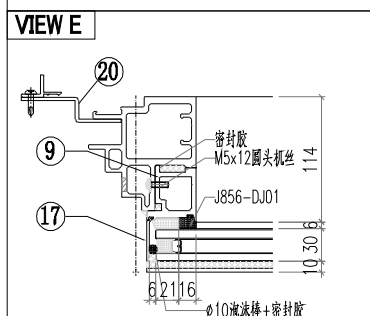
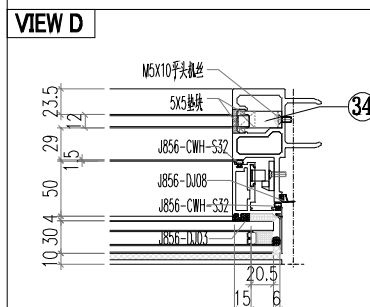
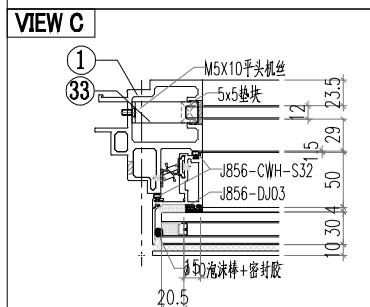
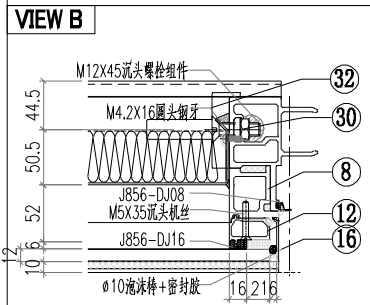
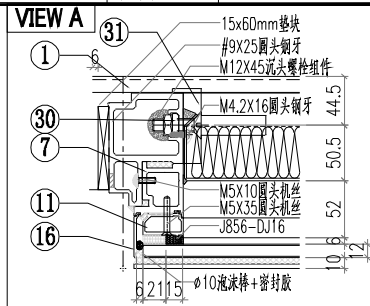
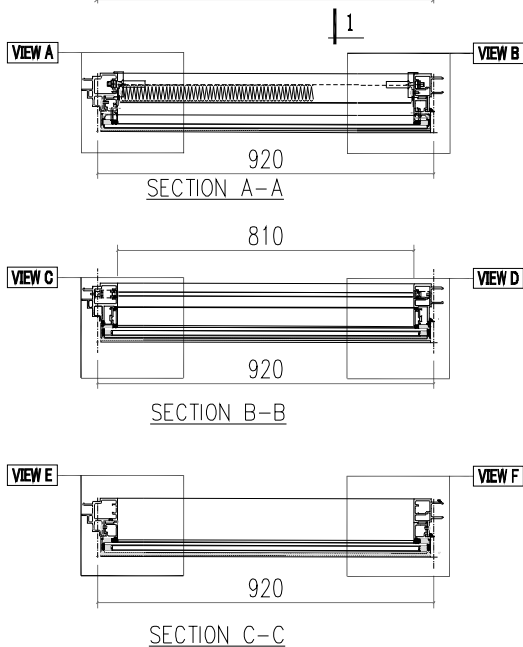
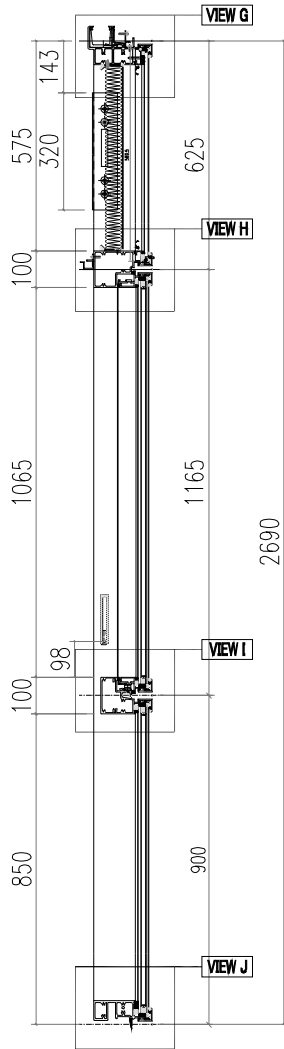
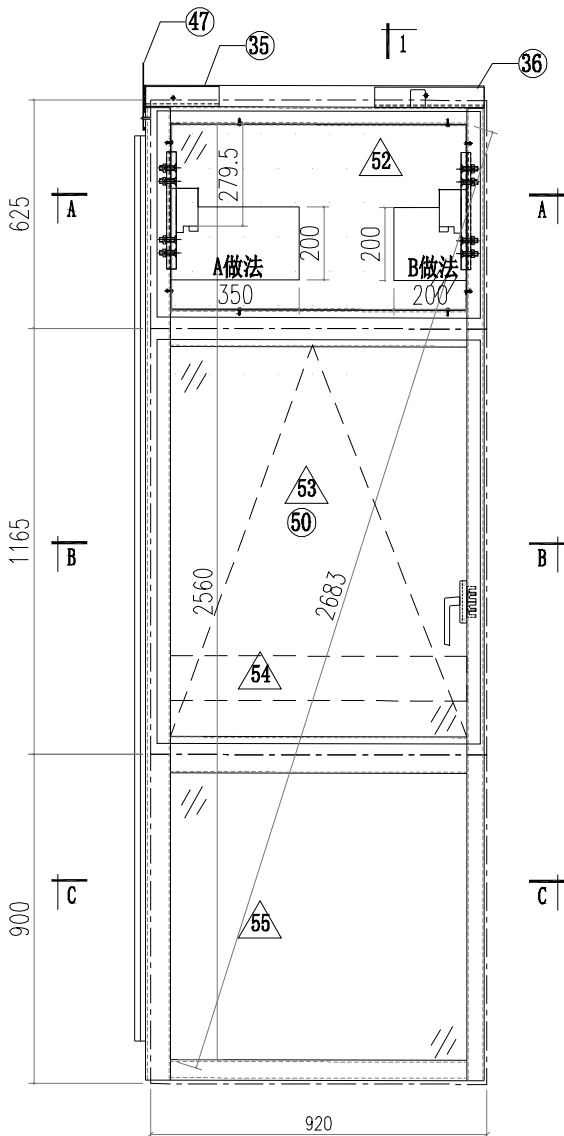

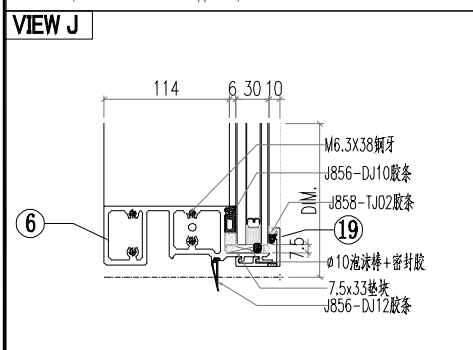
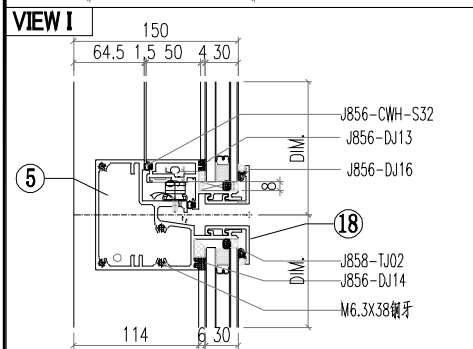
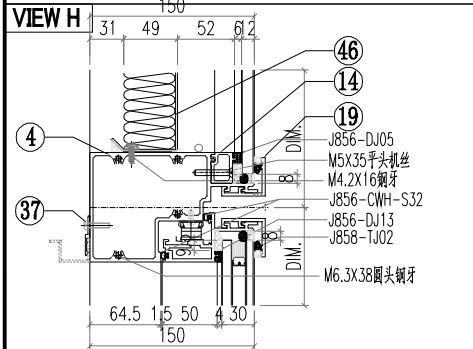
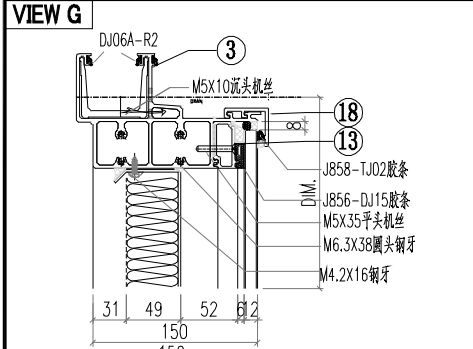
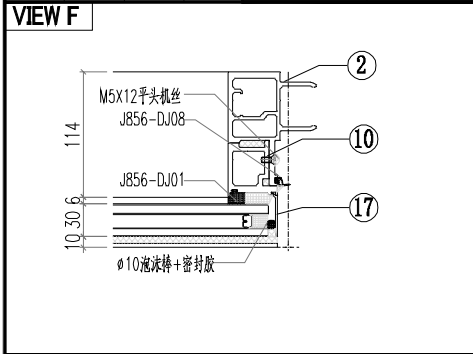

ALUM. EXTRUSION

ITEM	FAB. DWG NO.	LENGTH (mm)	QTY
1	X86367-SU03	2657	1
2	X86364-SU02	2657	1
3	AT01-SU02-004	940.5	1
4	AT04-SU02-003	900	1
5	AT05-SU02-003	900	1
6	AT02-SU01-003	894	1
7	AD06-T07	580	1
8	AD06-T08	580	1
9	AD06-P01	862	1
10	AD06-P02	862	1
11	X86371-T03	580.5	1
12	X86371-T04	580.5	1
13	X86374-SU01-08	808	1
14	X86375-SU01-08	808	1
15			
16	AC01-T01-02/AC01-T01R-2	597	2
17	AC01-P02-01/AC01-P02R-1	872	2
18	X86412-SU01-08	900	2
19	X86412-SK01-08	900	2
20	AX04-P04	1950	1
21			
22			
23			
24			
25			
26			
27			
28			
29			

OTHERS (ALUM. & G.M.S. PARTS)

ITEM	FAB. DWG NO.	LENGTH (mm)	QTY
46	BP-DA08		1
	808X508		
47	LB-P02		1
48			
49			
50	CE-012		
51			
52	PT-GL04-A13		1
	884X565		
53	PT-GL01-B07		1
	884X1105		
54	PT-GL05-A03		1
	840X122		
55	PT-GL01-A13		1
	884X840		

30	MS01-P01	320	2
31	X86372-P01	320	1
32	X86372-P02	320	1
33	J60*38-003	15	1
34	J60*38-002	15	1
35	GS01-K02	150	1
36	GS01-K01	300	1
37	AJ03-SU01-8	800	1
38			
39			
40			
41			
42			
43			
44			
45			

 美特鋁質有限公司 MIDI Aluminium Fabricator Ltd.		工程號 J856 地盘 天榮站 图纸名称 单元组装图 材料 -	類別 制圖 李傳鵬 復核 練松文 批准 林仁安	物料號 M1 2022-11-26 2022-11-27 2022-11-28	圖號 CW-421 數量 - 單件重量 - (KG)
修改 日期	採用工廠 材料颜色 -UCT542919XL-3	地盤 <input checked="" type="checkbox"/>			

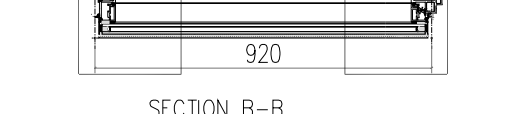
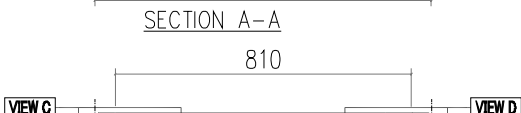
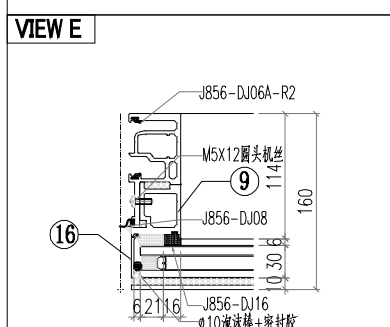
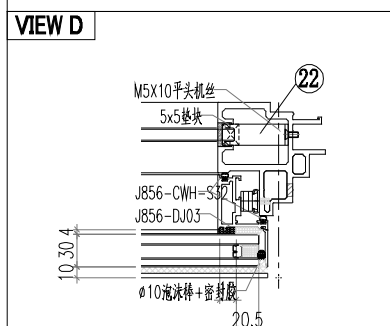
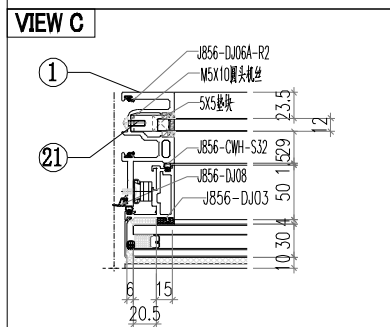
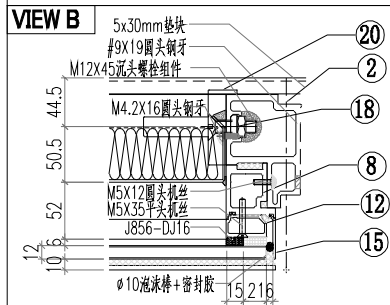
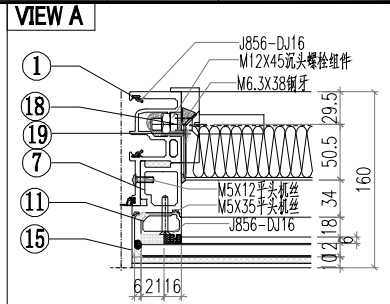
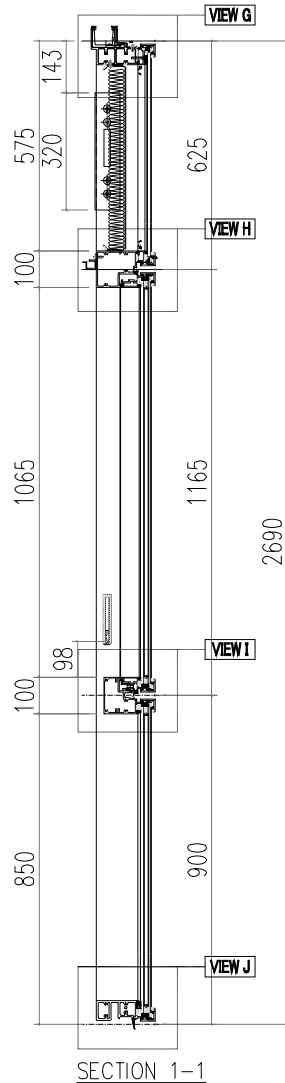
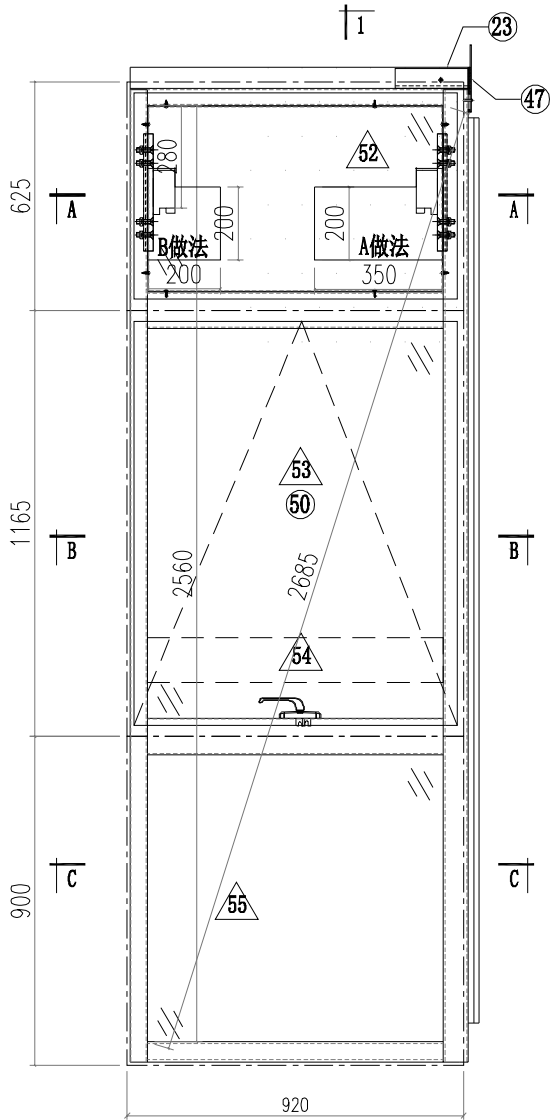

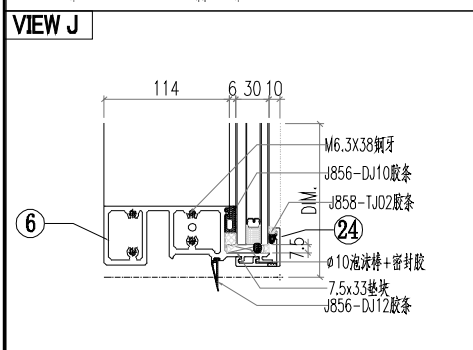
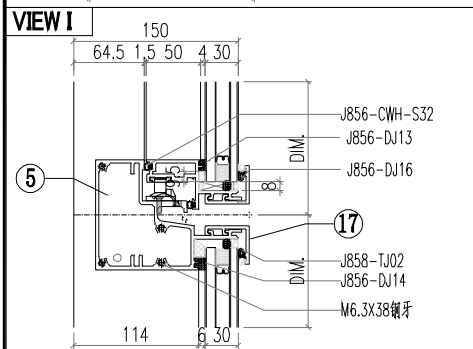
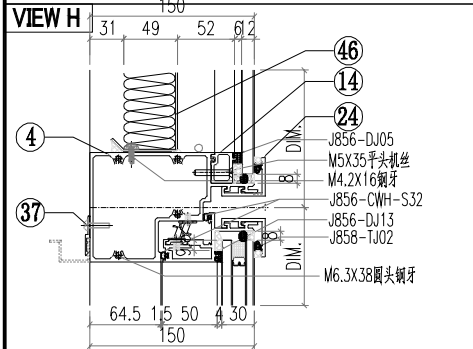
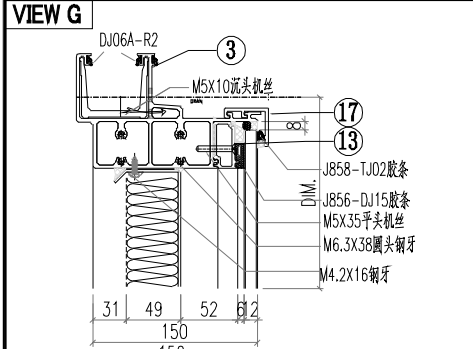
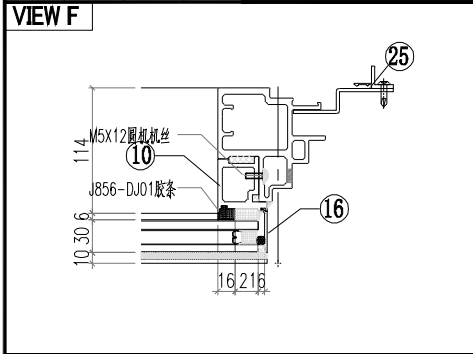

ALUM. EXTRUSION

ITEM	FAB. DWG NO.	LENGTH (mm)	QTY
1	X86365-SU03	2657	1
2	X86367-SU02	2657	1
3	AT01-SU03-003	940.5	1
4	AT04-SU02-003	900	1
5	AT05-SU02-003	900	1
6	AT02-SU01-003	894	1
7	AD06-T07	580	1
8	AD06-T08	580	1
9	AD06-P01	862	1
10	AD06-P02	862	1
11	X86371-T03	580.5	1
12	X86371-T04	580.5	1
13	X86374-SU01-08	808	1
14	X86375-SU01-08	808	1
15	AC01-T01-02/AC01-T01R-2	597	2
16	AC01-P02-01/AC01-P02R-1	872	2
17	X86412-SU01-08	900	2
18	MS01-P01	320	2
19	X86372-P01	320	1
20	X86372-P02	320	1
21	J60*38-001	15	1
22	J60*38-003	15	1
23	GS01-K02	150	1
24	X86412-SK01-08	900	2
25	AX04-P03	1950	1
26			
27			
28			
29			
30			

OTHERS (ALUM. & G.M.S. PARTS)

ITEM	FAB. DWG NO.	LENGTH (mm)	QTY
31			
32			
33			
34			
35			
36			
37	AJ03-SU01-08	800	1
38			
39			
40	CE-012		1
41			
42			
43			
44			
45			
46	BP-DA08		1
47	808X508		1
48	LB-P01		1
49			
50	PT-GL04-A13		1
51	884X565		1
52	PT-GL01-B07		1
53	884X1105		1
54	PT-GL05-A03		1
55	840X122		1
56	PT-GL01-A13		1
57	884X840		1

 美特鋁質有限公司 MIDI Aluminium Fabricator Ltd.		工程號 J856 地盤 天榮站 图纸名称 单元组装图 材料 -	類別 制圖 李傳鵬 復核 練松文 批准 林仁安	物料號 M1 2022-11-26 2022-11-27 2022-11-28	圖號 CW-422 數量 - 單件重量 - (KG)
修改 日期	採用工廠 材料颜色 -UCT542919XL-3	地盤 <input checked="" type="checkbox"/>			

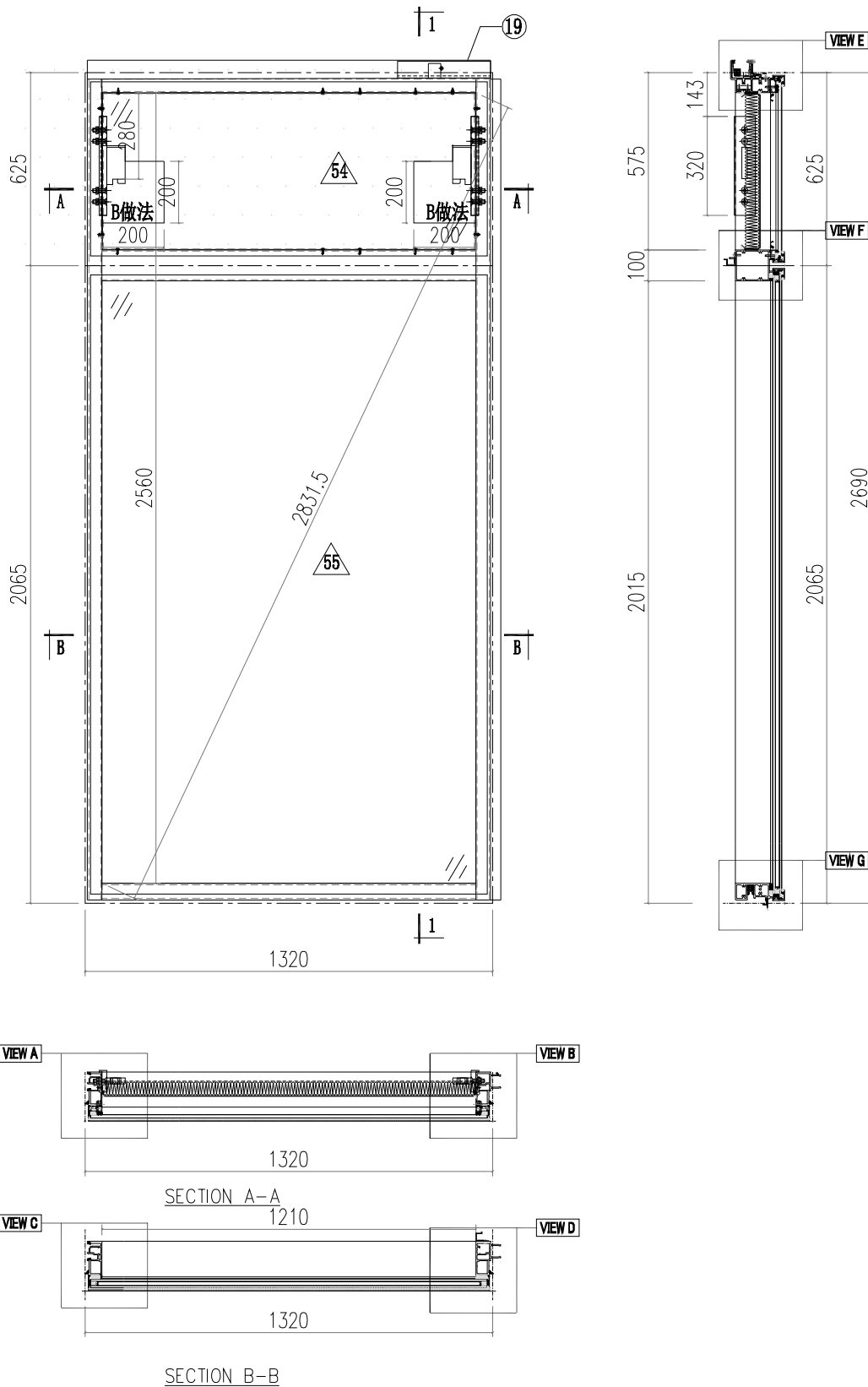

 美特鋁質有限公司 MIDI Aluminium Fabricator Ltd.		工程號 J856 地盤 天榮站	類別 制圖 李傳鵬 復核 練松文 批准 林仁安	物料號 M1 2022-11-26 2022-11-27 2022-11-28	圖號 CW-422 數量 - 單件重量 - (KG)
修改日期 採用工廠 地盤 ✓ 材料顏色 - UCT542919XL-3	图纸名称 单元组装图 材料 -				

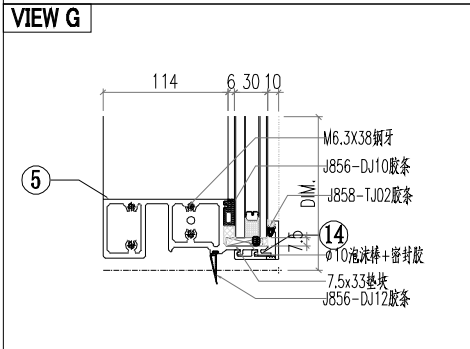
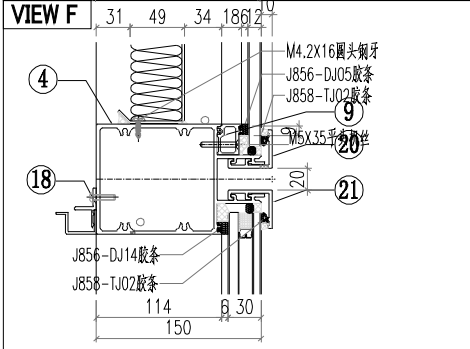
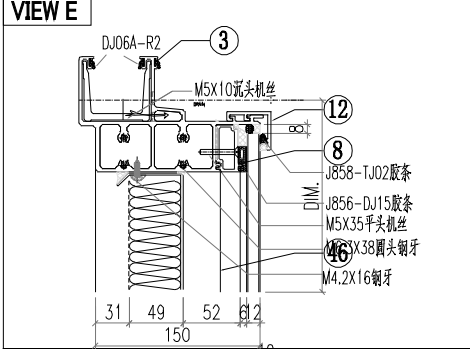
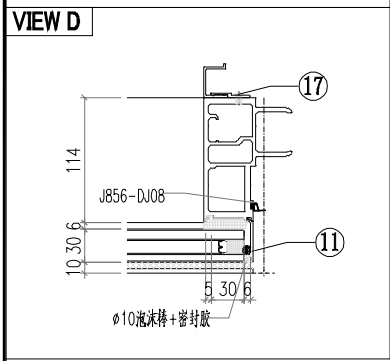
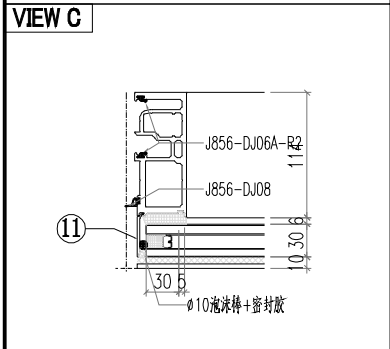
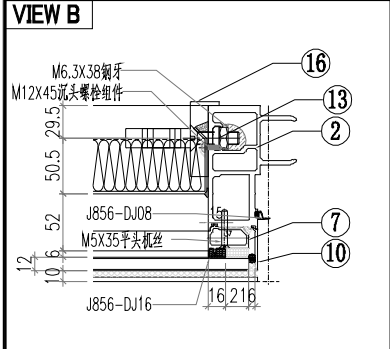
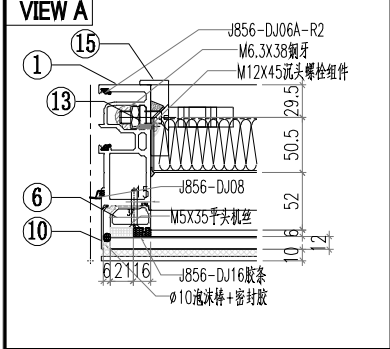

△ OTHERS (ALUM. & G.M.S. PARTS)

ITEM	FAB. DWG NO.	LENGTH (mm)	QTY
46	BP-DA09		1
	1208X508		
47			
48			
49			
50			
51			
52			
53			
54	PT-GL04-A15		1
	1284X565		
55	PT-GL01-A15		1
	1284X2005		

○ ALUM. EXTRUSION

ITEM	FAB. DWG NO.	LENGTH (mm)	QTY
1	AM02-SU01	2657	1
2	AM01-SU01	2657	1
3	AT01-SU01-009	1305	1
4	AT03-SU01-007	1294	1
5	AT02-SU02-007	1294	1
6	X86371-T04	580.5	1
7	X86371-T03	580.5	1
8	X86374-SU01-09	1208	1
9	X86375-SU01-09	1208	1
10	AC01-T01-02/AC01-T01R-2	597	2
11	AC01-P02-02/AC01-P02R-2	2037	2
12	X86412-SU01-09	1300	2
13	MS01-P01	320	2
14	X86412-SK01-09	1300	2
15	X86372-P01	320	1
16	X86372-P02	320	1
17	AJ04-P01	1950	1
18	AJ03-SU01-09	1200	1
19	GS01-K01	300	1
20			
21			
22			
23			
24			
25			
26			
27			
28			
29			
30			
31			
32			
33			
34			
35			
36			
37			
38			
39			
40			
41			
42			
43			
44			
45			

 美特鋁質有限公司 MIDI Aluminium Fabricator Ltd.		工程號 J856 地盘 天榮站	類別 制圖 李傳鵬 復核 練松文 批准 林仁安	物料號 M1 2022-11-26 2022-11-27 2022-11-28	圖號 CW-423 數量 - 單件重量 - (KG)
修改 日期	採用工廠 材料颜色 -UCT542919XL-3	图纸名称 单元组装机 材料 -			

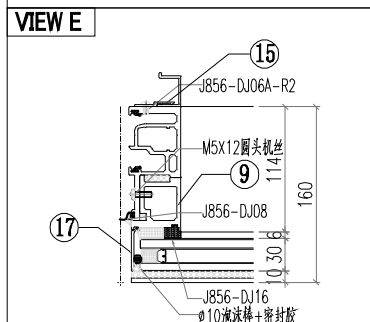
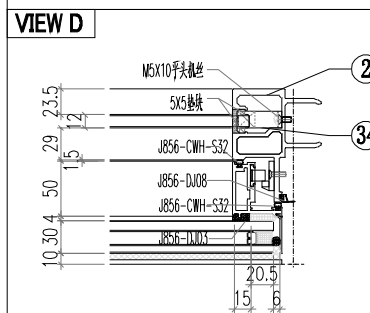
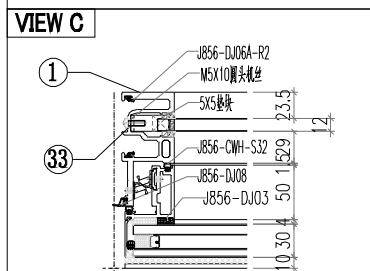
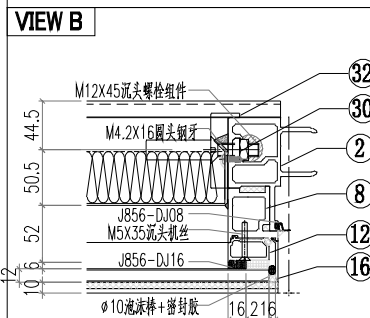
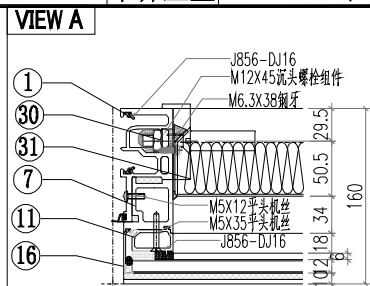
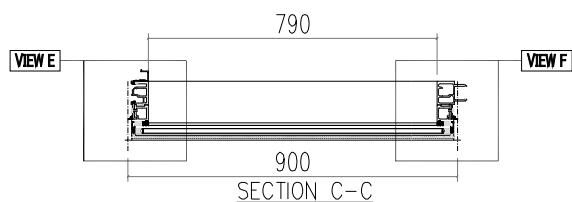
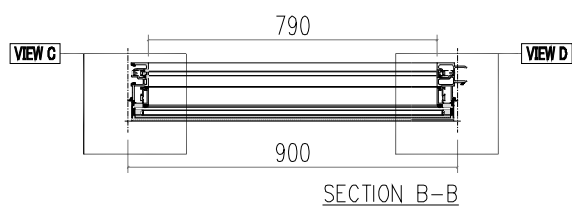
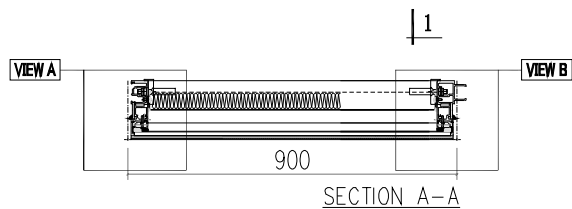
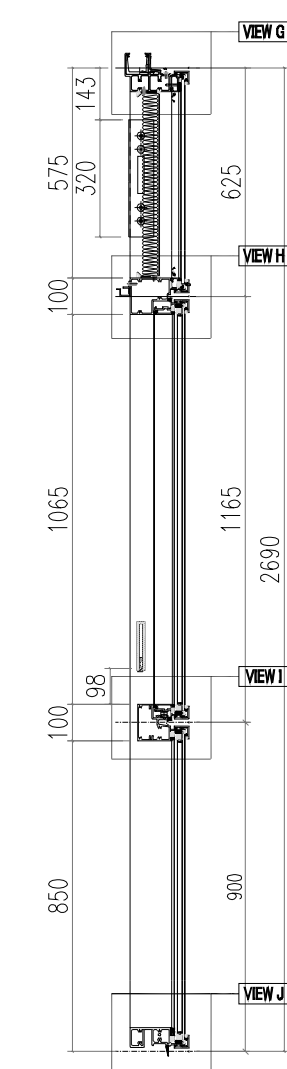
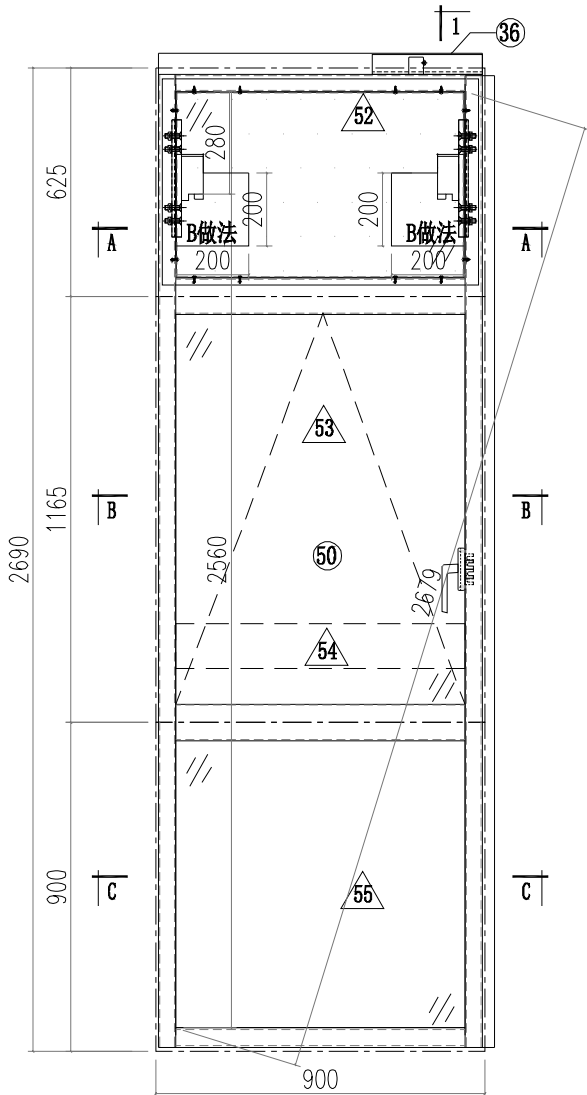

工程號	J856	類別		物料號	M1			
地盤	天榮站	制圖	李傳鵬	2022-11-26	圖號	CW-423		
修改		採用工廠	地盤	✓	日期			
日期		材料顏色	- UCT542919XL-3	材料	-	數量	-	
		材料	-	批准	林仁安	2022-11-28	單件重量	- (KG)

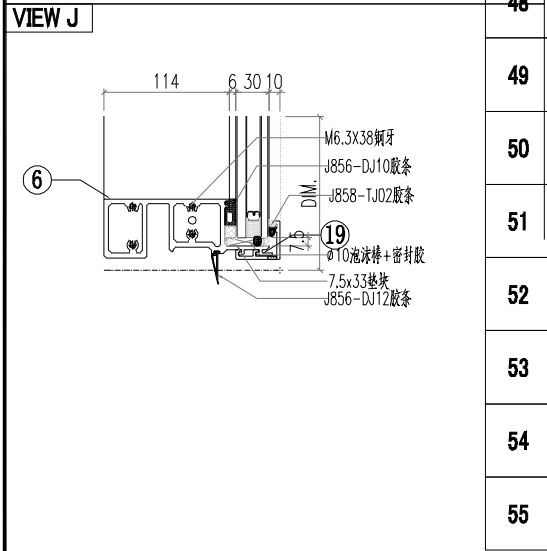
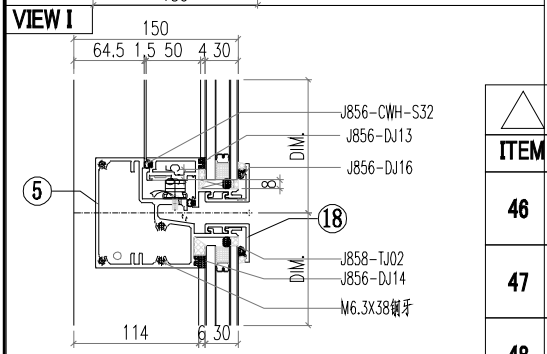
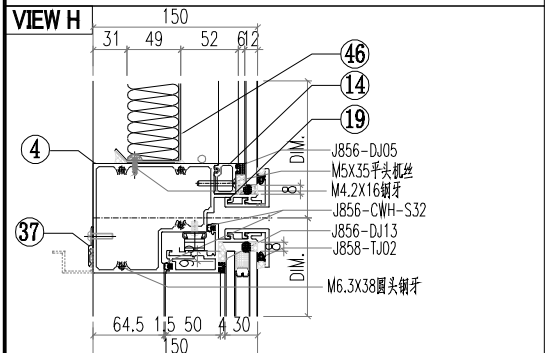
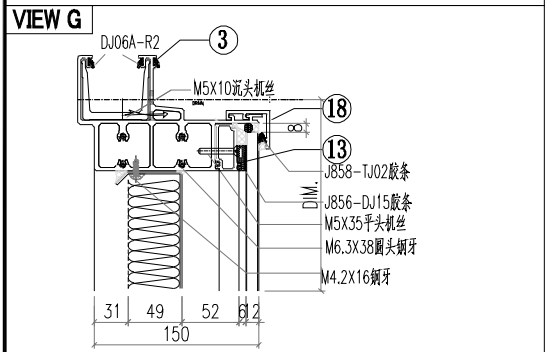
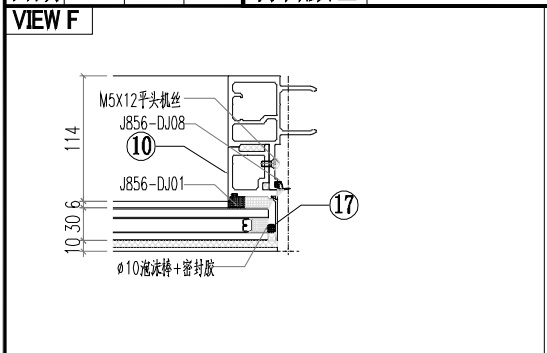

				ALUM. EXTRUSION		
ITEM	FAB. DWG NO.	LENGTH (mm)	QTY			
1	X86365-SU02	2657	1			
2	X86364-SU02	2657	1			
3	AT01-SU01-010	885	1			
4	AT04-SU02-004	880	1			
5	AT05-SU02-004	880	1			
6	AT02-SU01-004	874	1			
7	AD06-T07	580	1			
8	AD06-T08	580	1			
9	AD06-P01	862	1			
10	AD06-P02	862	1			
11	X86371-T03	580.5	1			
12	X86371-T04	580.5	1			
13	X86374-SU01-010	788	1			
14	X86375-SU01-010	788	1			
15	AJ04-P02	1950	1			
16	AC01-T01-02/AC01-T01R-2	597	2			
17	AC01-P02-01/AC01-P02R-1	872	2			
18	X86412-SU01-010	880	2			
19	X86412-SK01-010	880	2			
20						
21						
22						
23						
24						
25						
26						
27						
28						
29						
OTHERS (ALUM. & G.M.S. PARTS)						
ITEM	FAB. DWG NO.	LENGTH (mm)	QTY			
30	MS01-P01	320	2			
31	X86372-P01	320	1			
32	X86372-P02	320	1			
33	J60*38-001	15	1			
34	J60*38-002	15	1			
35						
36	GS01-K01	300	1			
37	AJ03-SU01-010	780	1			
38						
39						
40	CE-013		1			
41						
42						
43						
44						
45						
46	BP-DA10		1			
47	788X508					
48						
49						
50						
51						
52	PT-GL04-A16	864X565	1			
53	PT-GL01-B08	864X1105	1			
54	PT-GL05-A04	820X122	1			
55	PT-GL01-A16	864X840	1			

 美特鋁質有限公司 MIDI Aluminium Fabricator Ltd.		工程號 J856 地盤 天榮站 图纸名称 单元组装图 材料 -	類別 制圖 李傳鵬 復核 練松文 批准 林仁安	物料號 M1 2022-11-26 2022-11-27 2022-11-28	圖號 CW-424 數量 - 單件重量 - (KG)
修改 日期	採用工廠 材料颜色 -UCT542919XL-3	<input checked="" type="checkbox"/>			

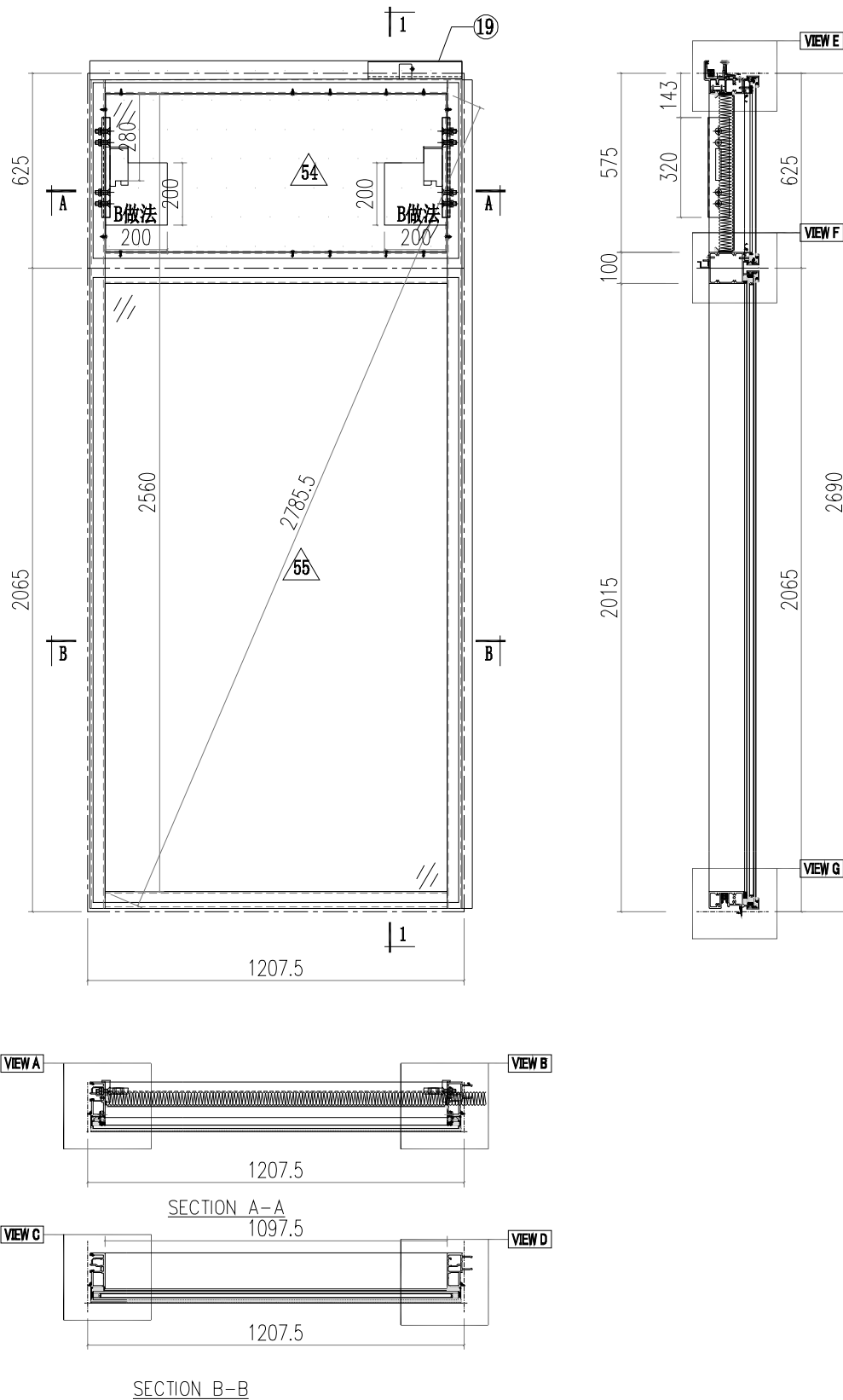

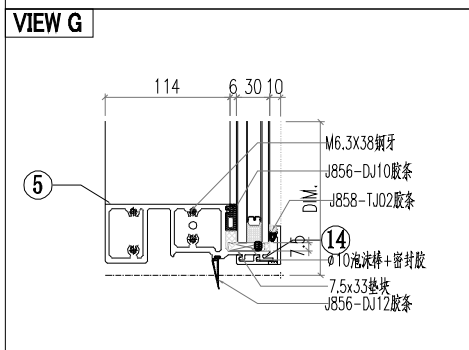
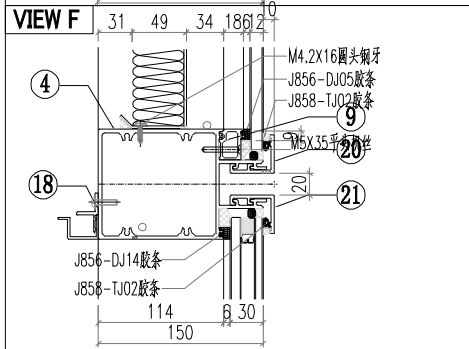
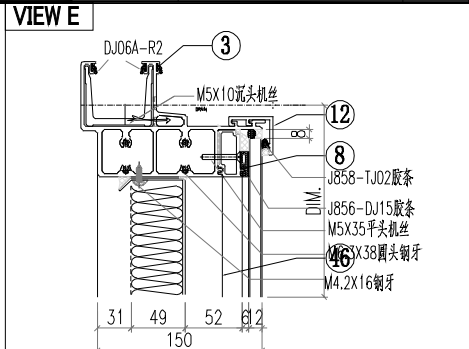
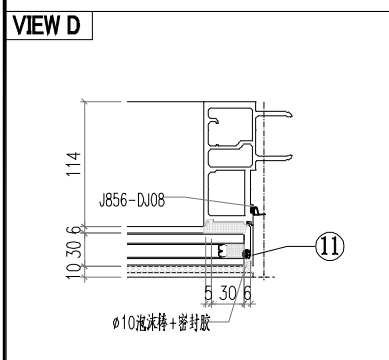
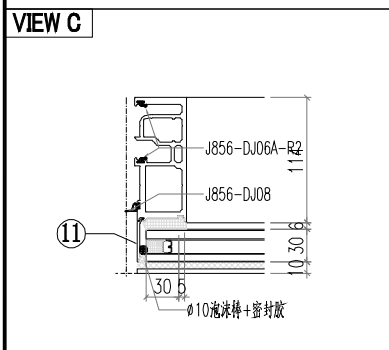
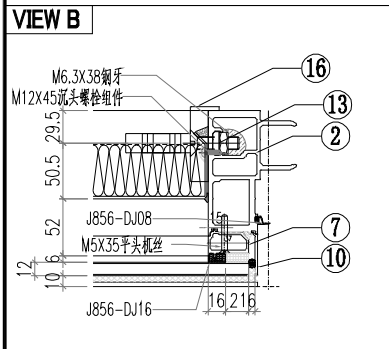
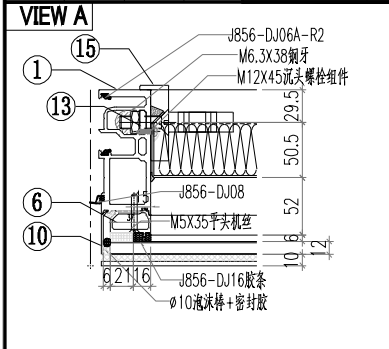

△ OTHERS (ALUM. & G.M.S. PARTS)			
ITEM	FAB. DWG NO.	LENGTH (mm)	QTY
46	BP-DA11		1
	1095.5X508		
47			
48			
49			
50			
51			
52			
53			
54	PT-GL04-A17		1
	1171.5X565		
55	PT-GL01-A17		1
	1171.5X2005		

○ ALUM. EXTRUSION			
ITEM	FAB. DWG NO.	LENGTH (mm)	QTY
1	AM02-SU01	2657	1
2	AM01-SU02	2657	1
3	AT01-SU01-011	1192.5	1
4	AT03-SU01-008	1181.5	1
5	AT02-SU02-008	1181.5	1
6	X86371-T04	580.5	1
7	X86371-T03	580.5	1
8	X86374-SU01-011	1095.5	1
9	X86375-SU01-011	1095.5	1
10	AC01-T01-02/AC01-T01R-2	597	2
11	AC01-P02-02/AC01-P02R-2	2037	2
12	X86412-SU01-11	1187.5	2
13	MS01-P01	320	2
14	X86412-SK01-11	1187.5	2
15	X86372-P01	320	1
16	X86372-P02	320	1
17			
18	AJ03-SU01-011	1087.5	1
19	GS01-K01	300	1
20			
21			
22			
23			
24			
25			
26			
27			
28			
29			
30			
31			
32			
33			
34			
35			
36			
37			
38			
39			
40			
41			
42			
43			
44			
45			

 美特鋁質有限公司 MIDI Aluminium Fabricator Ltd.		工程號 J856 地盘 天榮站 图纸名称 单元组装图 材料 -	類別 制圖 李傳鵬 復核 練松文 批准 林仁安	物料號 M1 圖號 CW-425 數量 - 單件重量 - (KG)
修改 日期	採用工廠 材料颜色 -UCT542919XL-3	地盤 <input checked="" type="checkbox"/>		

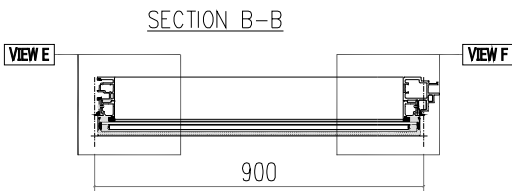
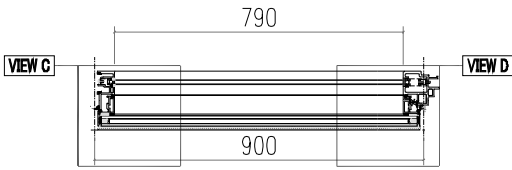
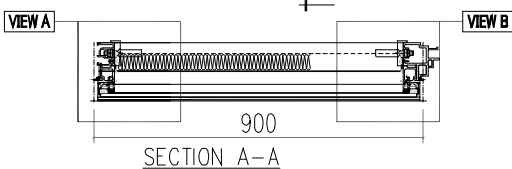
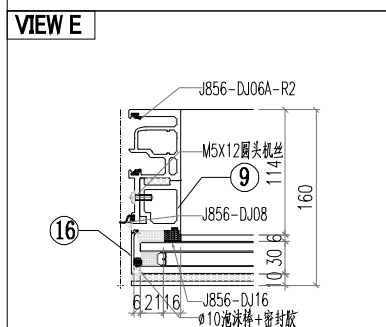
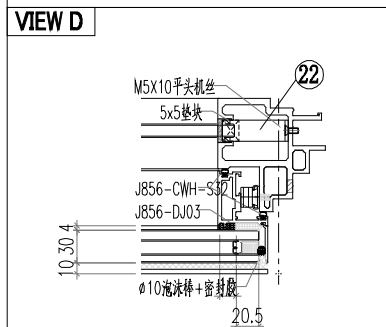
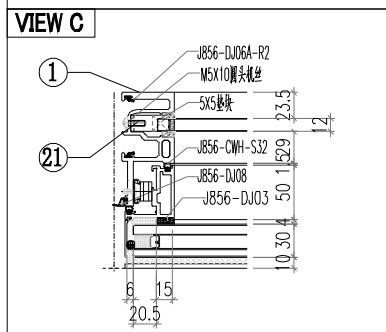
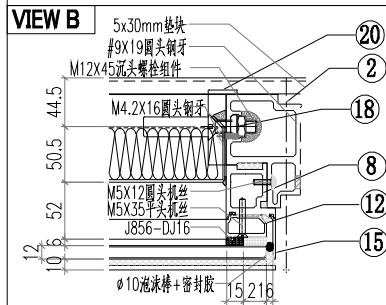
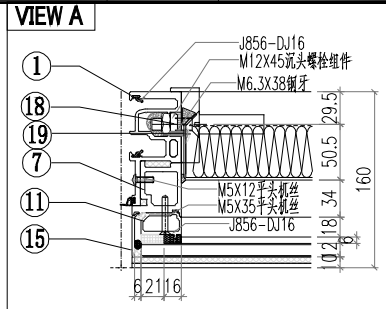
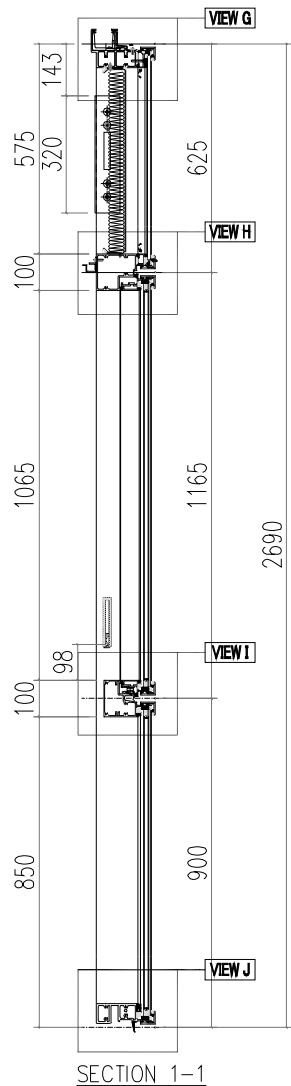
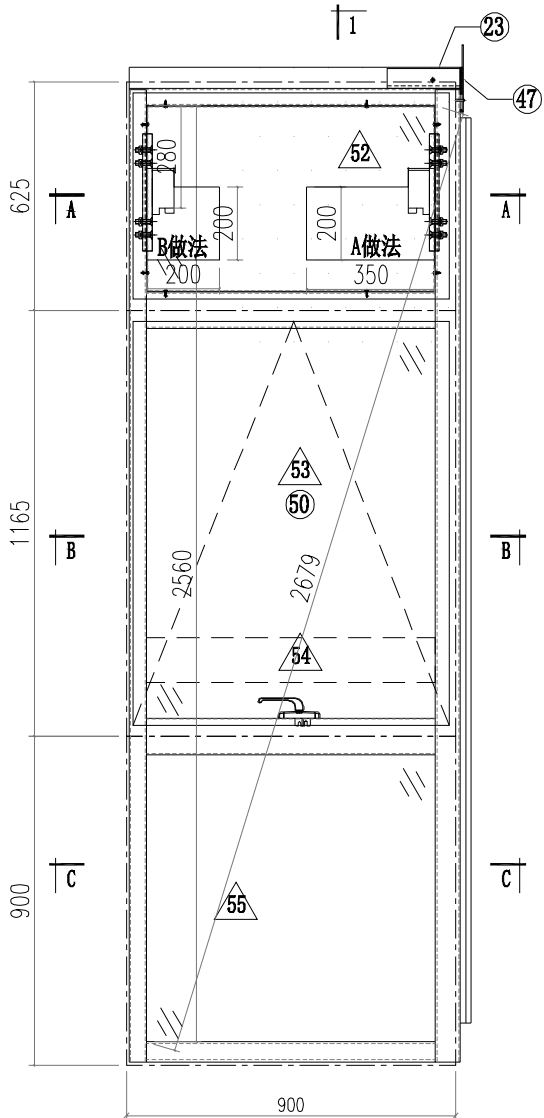

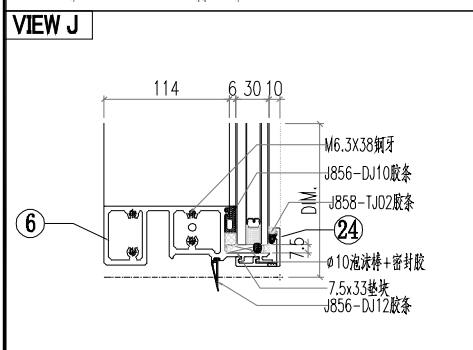
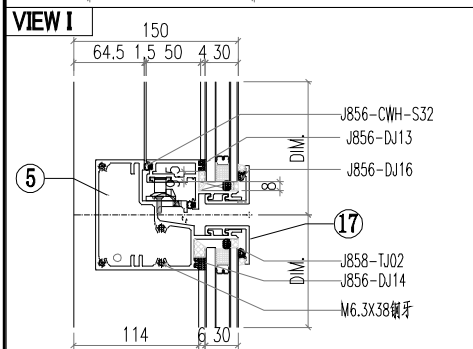
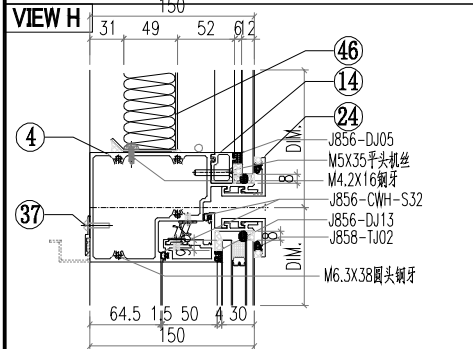
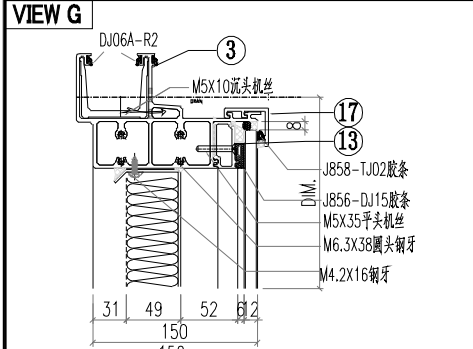
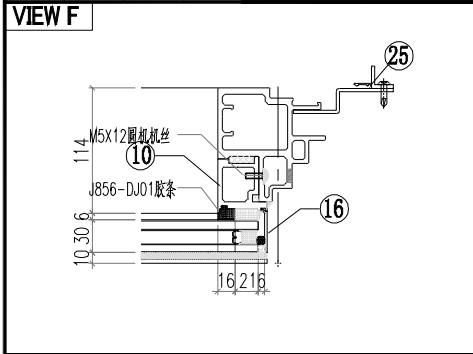

ALUM. EXTRUSION

ITEM	FAB. DWG NO.	LENGTH (mm)	QTY
1	X86365-SU03	2657	1
2	X86367-SU02	2657	1
3	AT01-SU03-004	920.5	1
4	AT04-SU02-004	880	1
5	AT05-SU02-004	880	1
6	AT02-SU01-004	874	1
7	AD06-T07	580	1
8	AD06-T08	580	1
9	AD06-P01	862	1
10	AD06-P02	862	1
11	X86371-T03	580.5	1
12	X86371-T04	580.5	1
13	X86374-SU01-010	788	1
14	X86375-SU01-010	788	1
15	AC01-T01-02/AC01-T01R-2	597	2
16	AC01-P02-01/AC01-P02R-1	872	2
17	X86412-SU01-010	880	2
18	MS01-P01	320	2
19	X86372-P01	320	1
20	X86372-P02	320	1
21	J60*38-001	15	1
22	J60*38-003	15	1
23	GS01-K02	150	1
24	X86412-SK01-010	880	2
25	AX04-P03	1950	1
26			
27			
28			
29			
30			

OTHERS (ALUM. & G.M.S. PARTS)

ITEM	FAB. DWG NO.	LENGTH (mm)	QTY
46	BP-DA10		1
	788X508		
47	LB-P01		1
48			
49			
50	CE-013		1
51			
52	PT-GL04-A16		1
	864X565		
53	PT-GL01-B08		1
	864X1105		
54	PT-GL05-A04		1
	820X122		
55	PT-GL01-A16		1
	864X840		

31			
32			
33			
34			
35			
36			
37	AJ03-SU01-010	780	1
38			
39			
40			
41			
42			
43			
44			
45			

 美特鋁質有限公司 MIDI Aluminium Fabricator Ltd.			工程號 J856 地盘 天榮站	類別 制圖 李傳鵬 復核 練松文 批准 林仁安	物料號 M1 2022-11-26 2022-11-27 2022-11-28	圖號 AM06-SU01 數量 - 單件重量 - (KG)
修改 日期	採用工廠 材料颜色 -UCT542919XL-3	地盤 <input checked="" type="checkbox"/>	图纸名称 铝料加工图 材料 AM06			

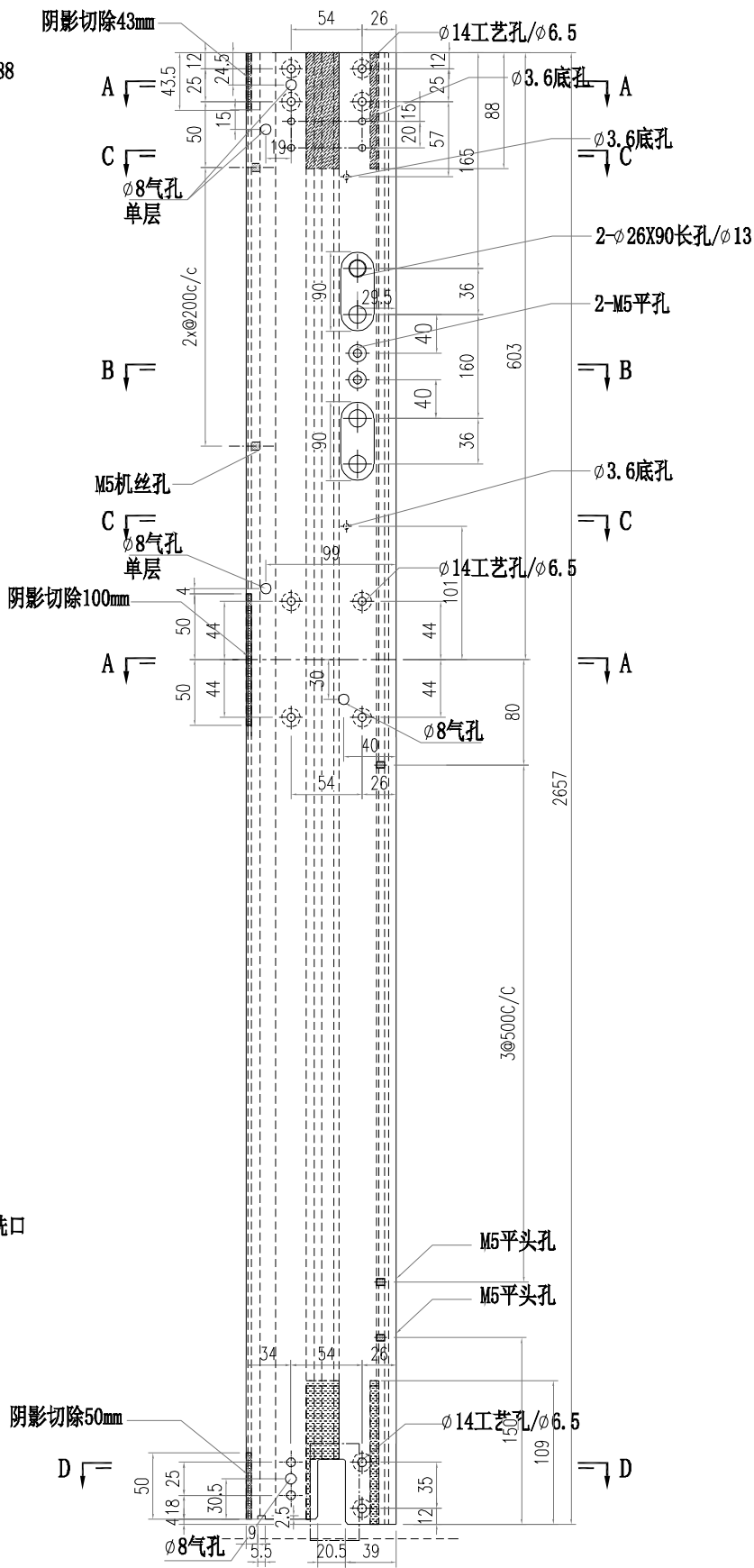
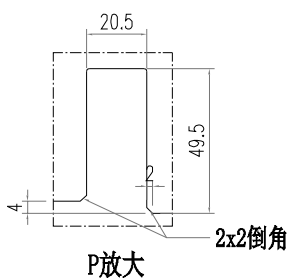
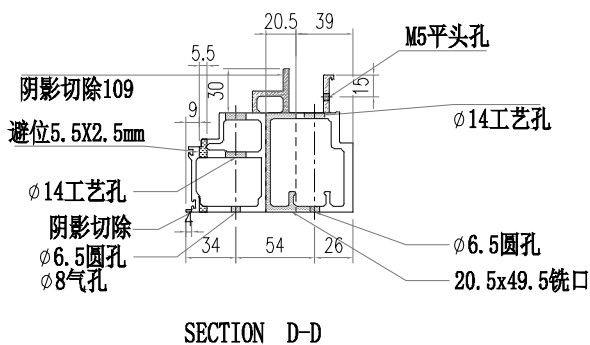
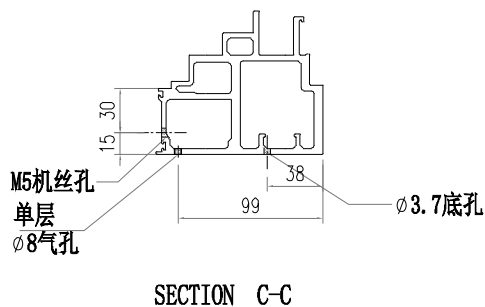
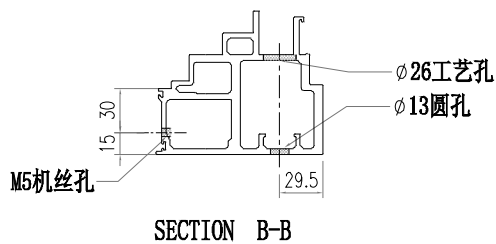
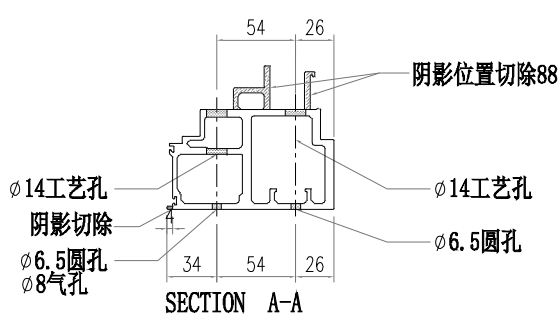

 美特鋁質有限公司 MIDI Aluminium Fabricator Ltd.			工程號 J856 地盘 天榮站	類別 制圖 李傳鵬 復核 練松文 批准 林仁安	物料號 M1 2022-11-26 2022-11-27 2022-11-28	圖號 X86367-SU01 數量 - 單件重量 - (KG)	
修改 日期	採用工廠 材料颜色 UCT542919XL-B	地盘 <input checked="" type="checkbox"/>	图纸名称 铝料加工图 B 材料 X86367				

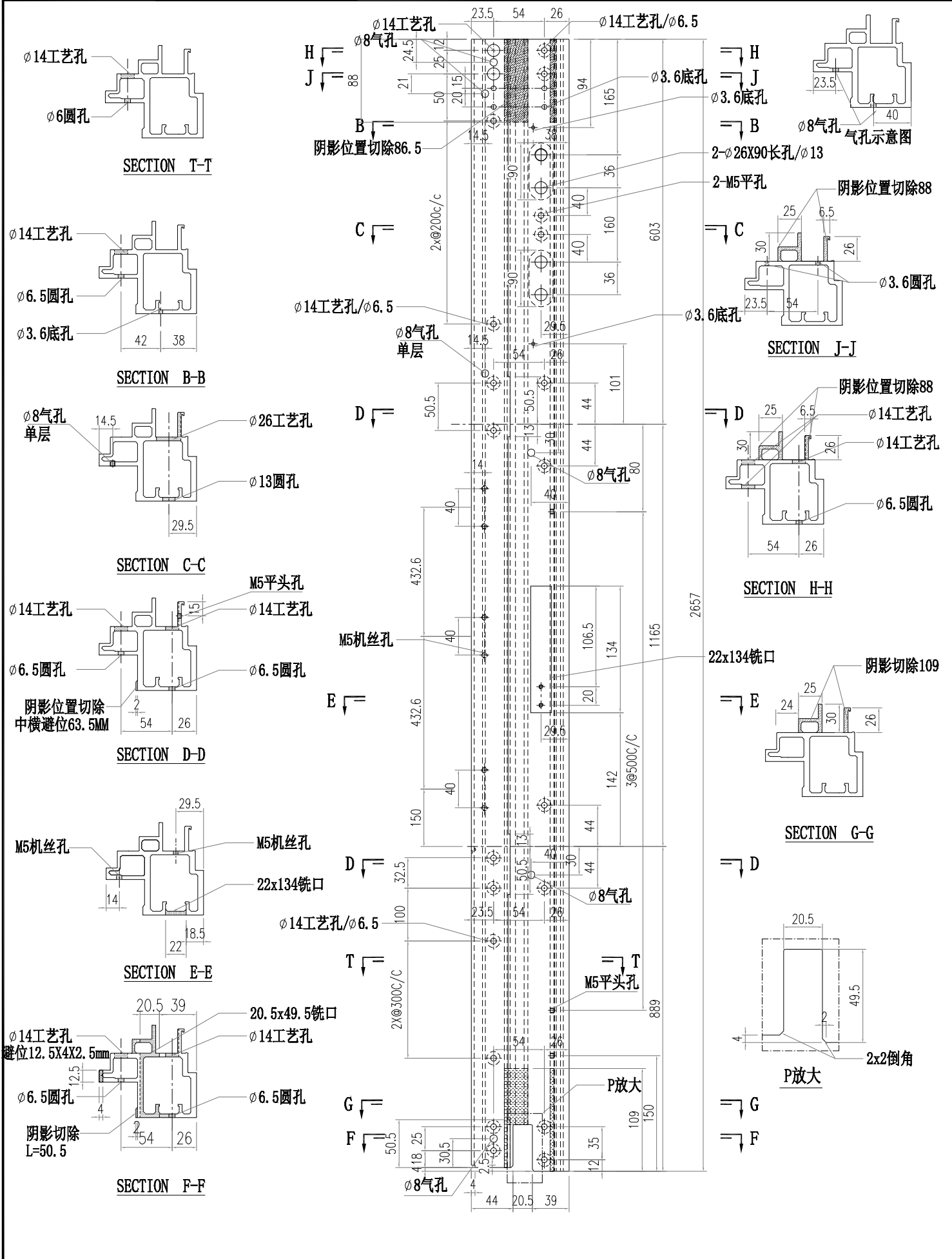

 美特鋁質有限公司 MIDI Aluminium Fabricator Ltd.		工程號 J856 地盘 天榮站	類別 制圖 李傳鵬 復核 練松文 批准 林仁安	物料號 M1 2022-11-26 2022-11-27 2022-11-28	圖號 X86367-SU04 數量 - 單件重量 - (KG)
修改 日期	採用工廠 材料颜色 UCT542919XL-B	图纸名称 铝料加工图 材料 X86367			

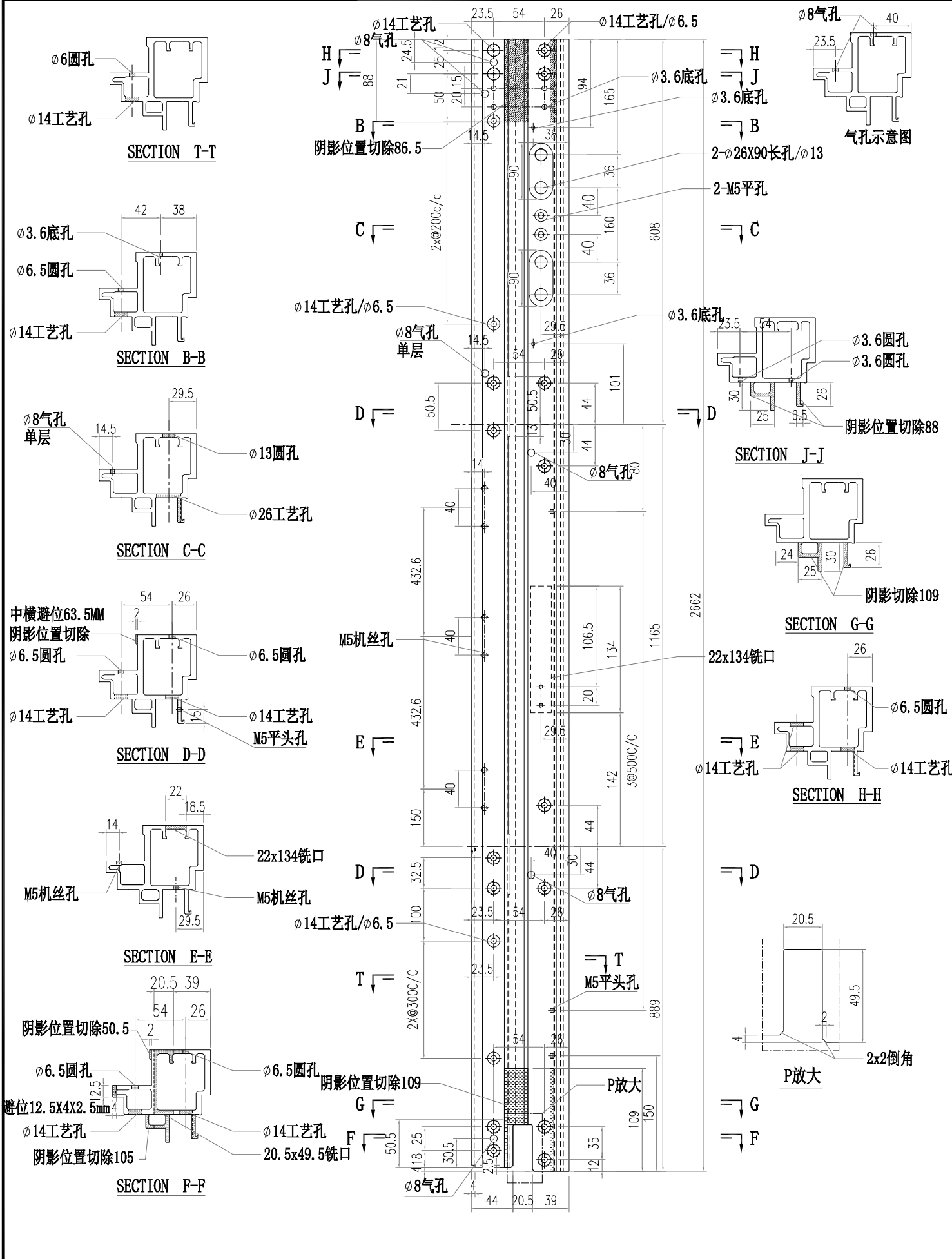

 美特鋁質有限公司 MIDI Aluminium Fabricator Ltd.			工程號 J856 地盘 天榮站	類別 制圖 李傳鵬 復核 練松文 批准 林仁安	物料號 M1 2022-11-26 2022-11-27 2022-11-28	圖號 X86364-SU01 數量 - 單件重量 - (KG)
修改 日期	採用工廠 材料颜色 -UCT542919XL-3	图纸名称 铝料加工图 材料 X86364				

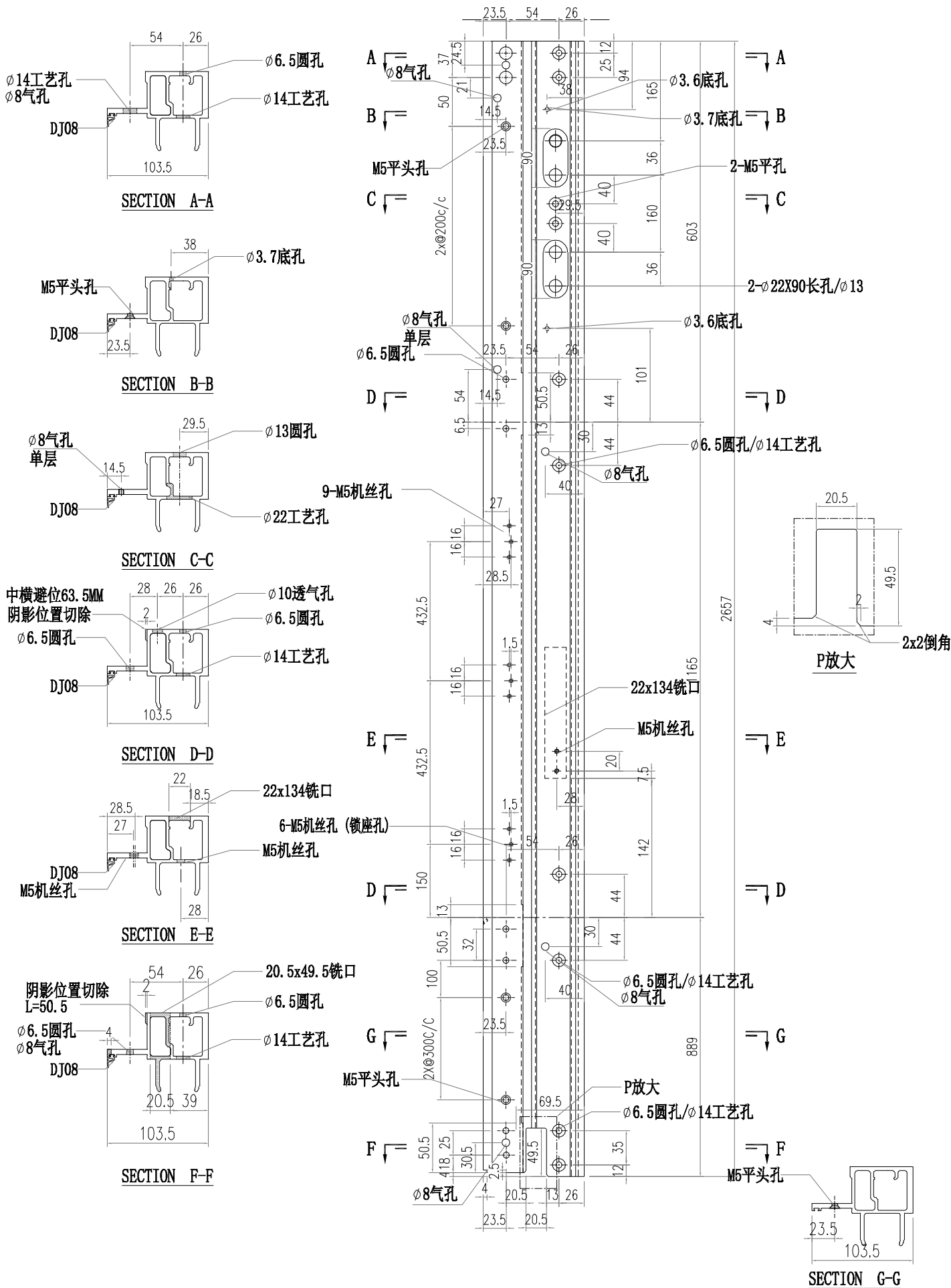

 美特铝质有限公司 MIDI Aluminium Fabricator Ltd.			工程號 J856 地盘 天榮站	類別 制圖 李傳鵬 復核 練松文 批准 林仁安	物料號 M1 圖號 X86364-SU02 數量 - 單件重量 - (KG)
修改 日期	採用工廠 材料顏色 -UCT542919XL-3	地盤 ✓ 图纸名称 铝料加工图 材料 X86364	2022-11-26 2022-11-27 2022-11-28	2022-11-26 2022-11-27 2022-11-28	2022-11-26 2022-11-27 2022-11-28

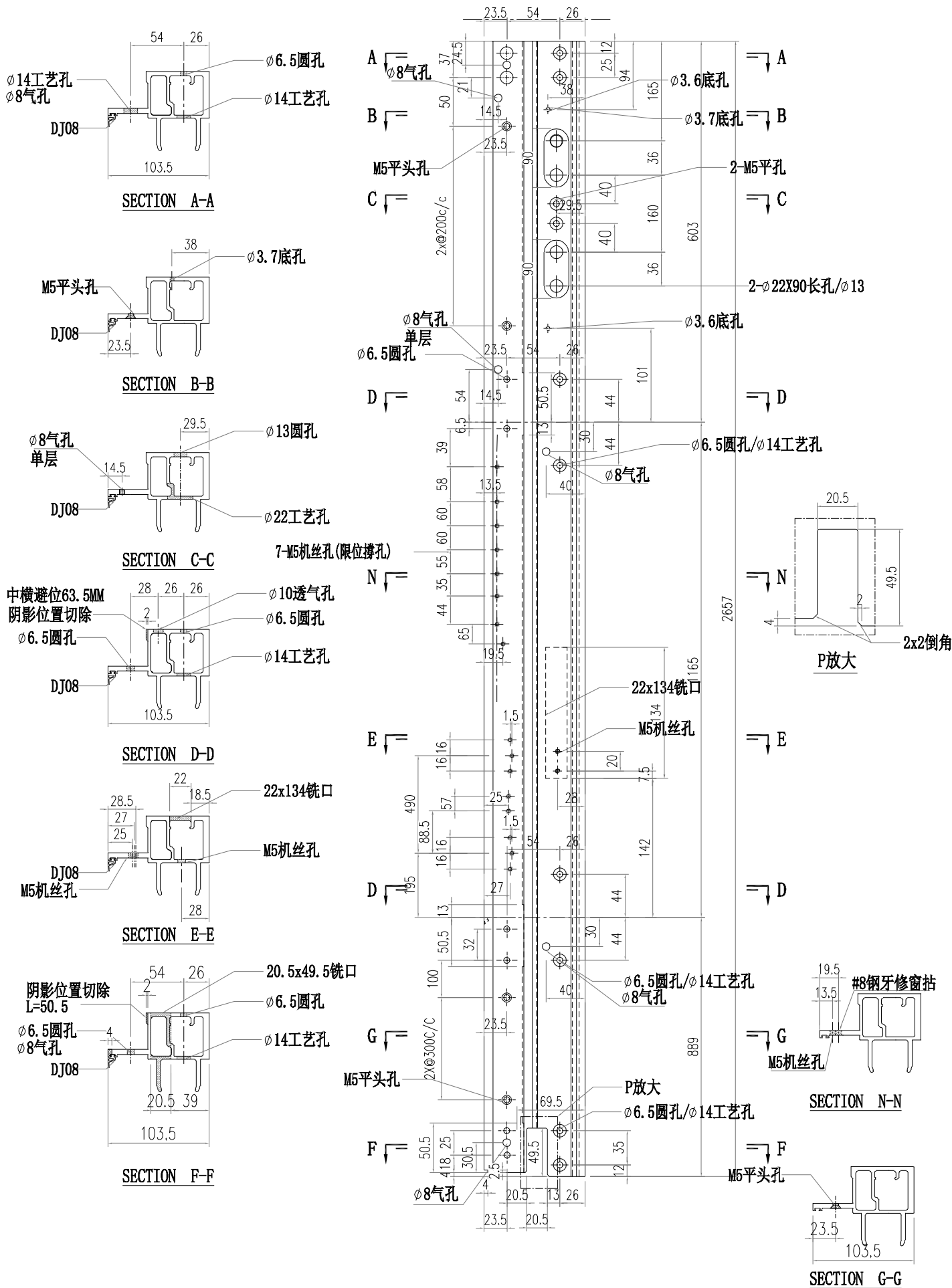

 美特铝质有限公司 MIDI Aluminium Fabricator Ltd.		工程號 J856 地盘 天榮站	類別 制圖 李傳鵬 復核 練松文 批准 林仁安	物料號 M1 圖號 X86364-SU03 數量 - 單件重量 - (KG)
修改 日期	採用工廠 材料颜色 -UCT542919XL-3	图纸名称 铝料加工图 材料 X86364	日期 2022-11-26 日期 2022-11-27 日期 2022-11-28	圖號 X86364-SU03 數量 - 單件重量 - (KG)

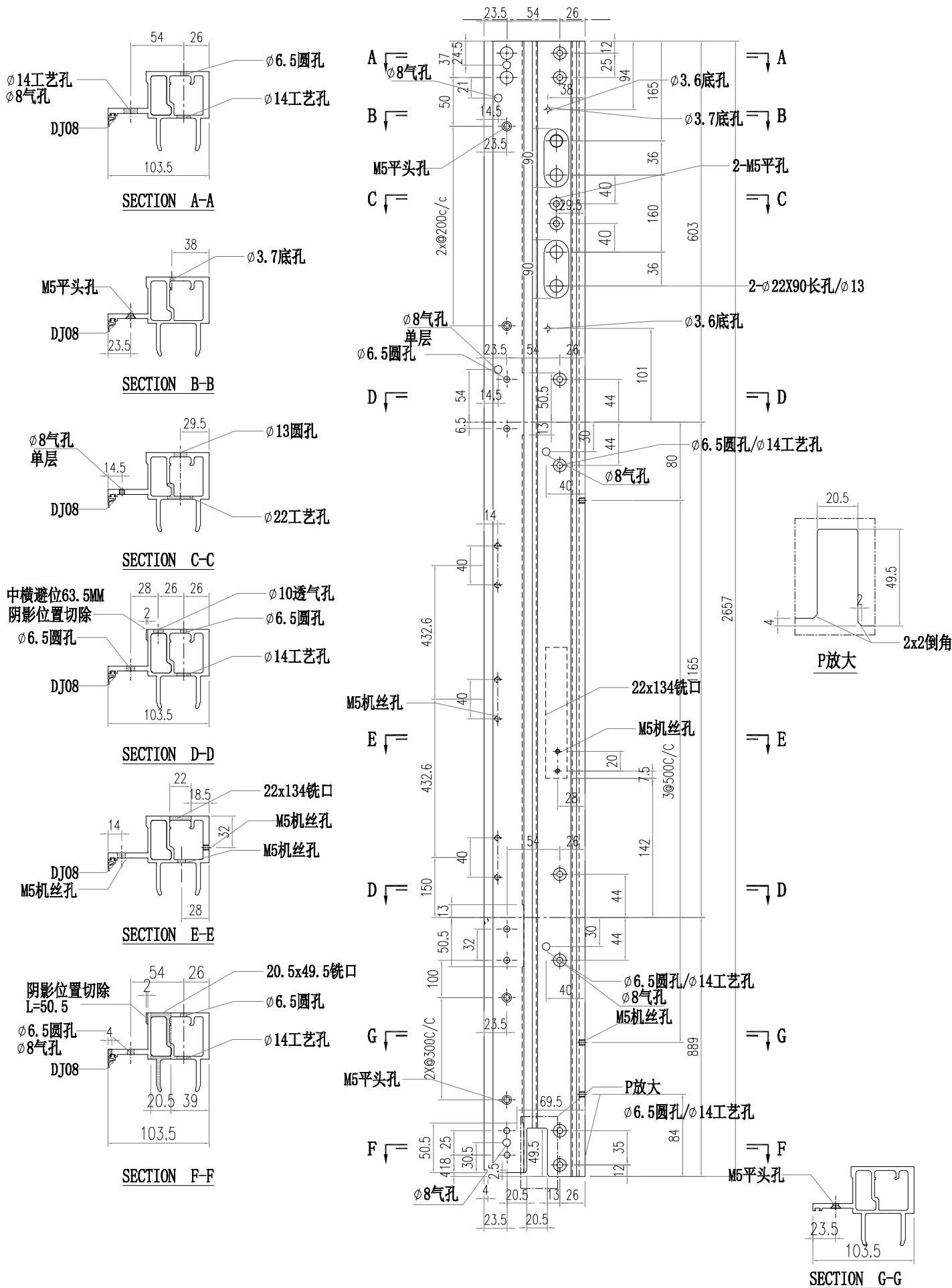

 美特铝质有限公司 MIDI Aluminium Fabricator Ltd.		工程號 J856 地盘 天榮站	類別 制圖 李傳鵬 復核 練松文 批准 林仁安	物料號 M1 圖號 X86364-SU04 數量 - 單件重量 - (KG)
修改 日期	採用工廠 材料顏色 -UCT542919XL-3	图纸名称 铝料加工图 材料 X86364		

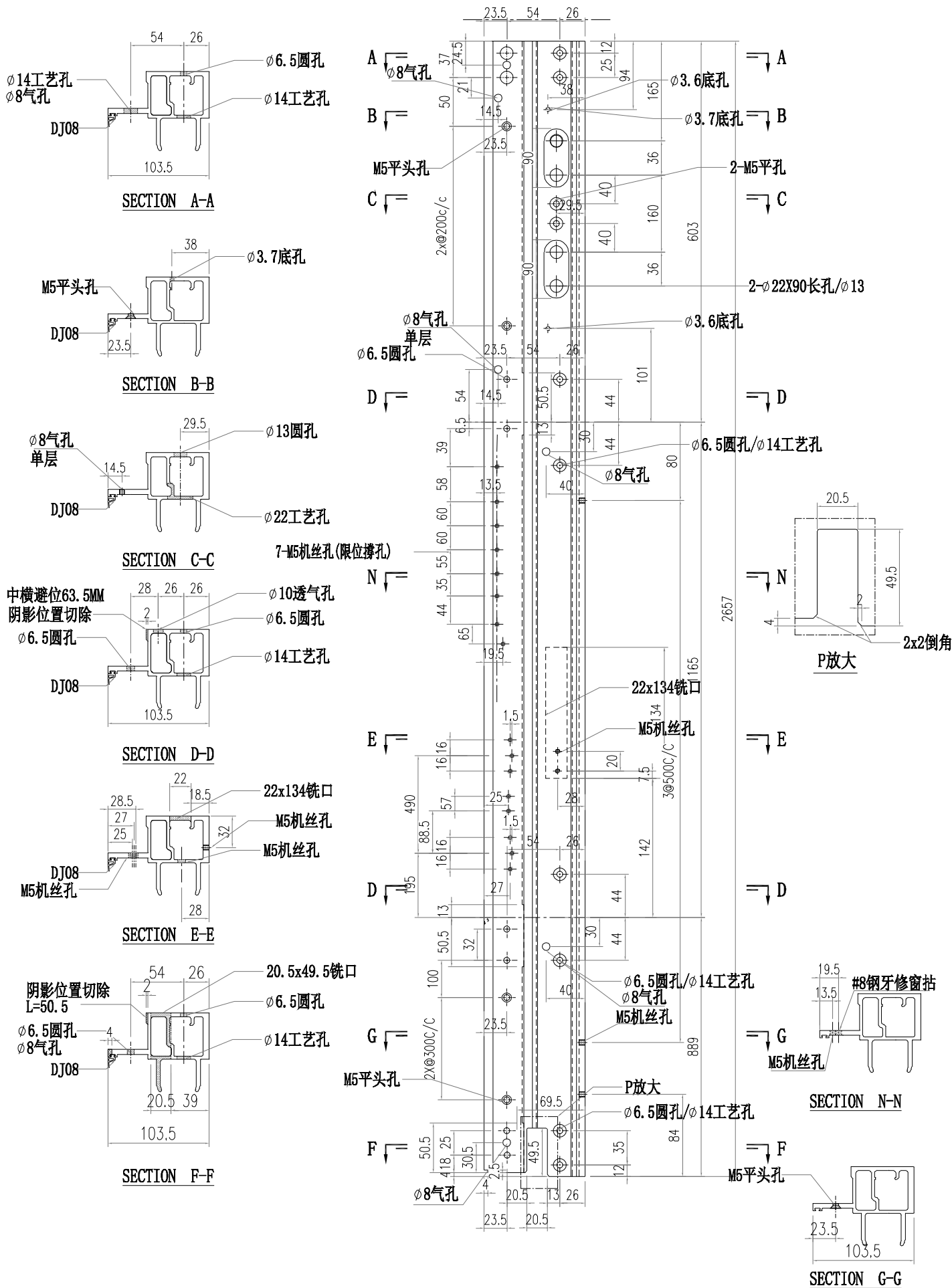

 美特鋁質有限公司 MIDI Aluminium Fabricator Ltd.			工程號 J856 地盘 天榮站	類別 制圖 李傳鵬 復核 練松文 批准 林仁安	物料號 M1 2022-11-26 2022-11-27 2022-11-28	圖號 AM02-SU01 數量 - 單件重量 - (KG)
修改 日期	採用工廠 材料颜色 -UCT542919XL-3	地盤 <input checked="" type="checkbox"/>	图纸名称 铝料加工图 材料 AM02			

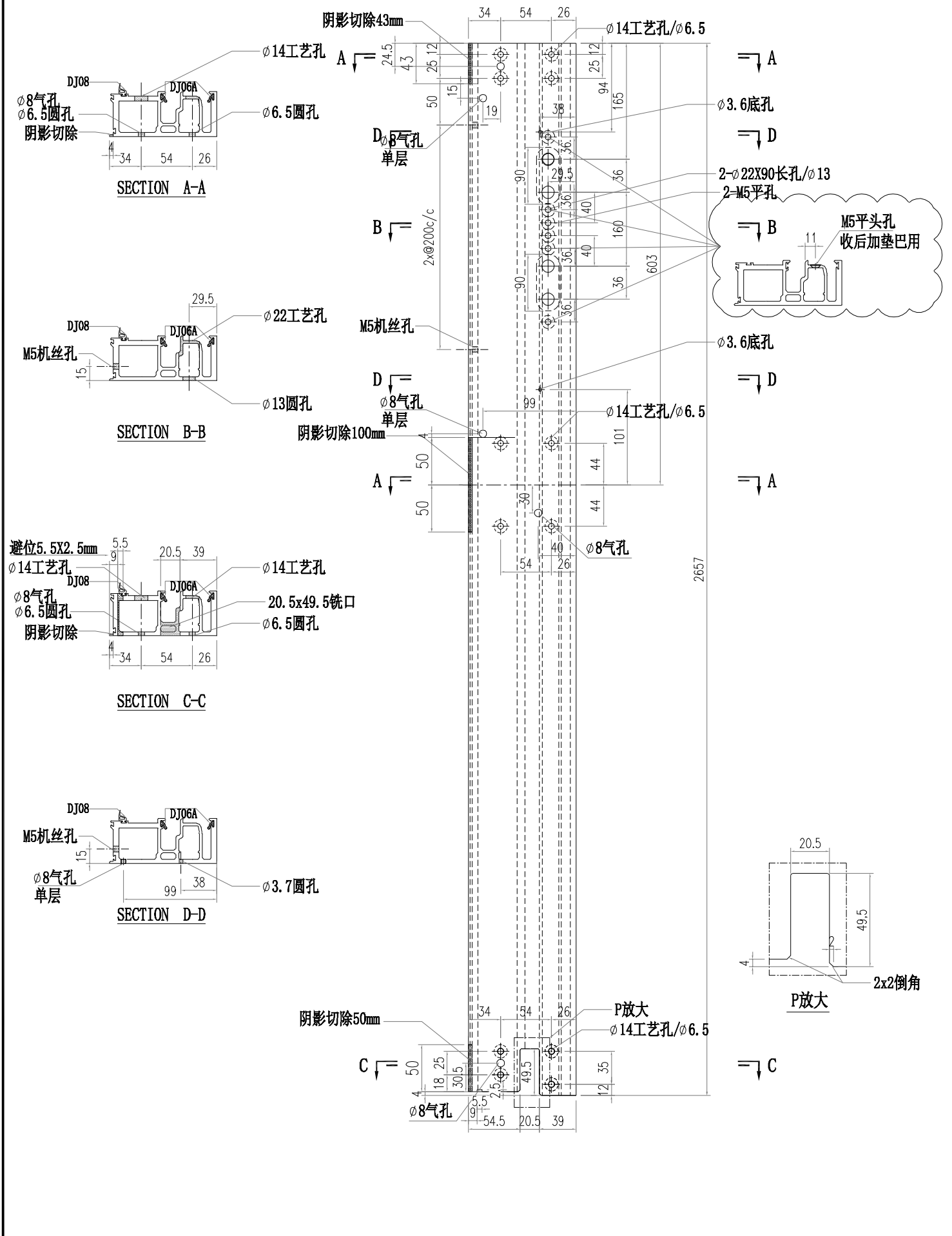

 美特鋁質有限公司 MIDI Aluminium Fabricator Ltd.		工程號 J856 地盘 天榮站	類別 制圖 李傳鵬 復核 練松文 批准 林仁安	物料號 M1 2022-11-26 2022-11-27 2022-11-28	圖號 AM02-SU02 數量 - 單件重量 - (KG)
修改 日期	採用工廠 材料颜色 -UCT542919XL-3	图纸名称 铝料加工图 材料 AM02			

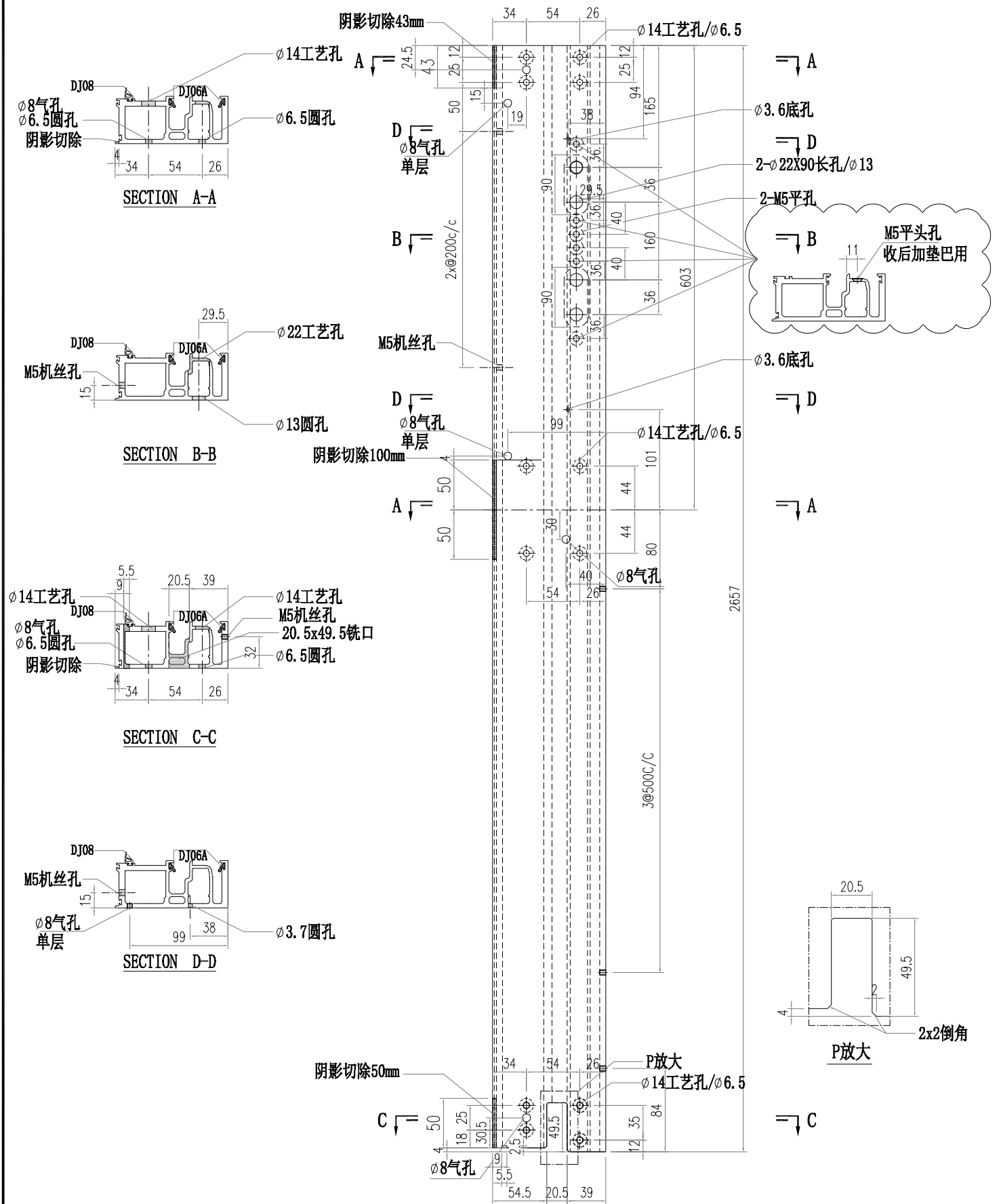

 美特鋁質有限公司 MIDI Aluminium Fabricator Ltd.			工程號 J856 地盘 天榮站	類別 制圖 李傳鵬 復核 練松文 批准 林仁安	物料號 M1 2022-11-26 2022-11-27 2022-11-28	圖號 AM01-SU02 數量 - 單件重量 - (KG)
修改 日期	採用工廠 材料颜色 -UCT542919XL-3	地盤 <input checked="" type="checkbox"/>	图纸名称 铝料加工图 材料 AM01			

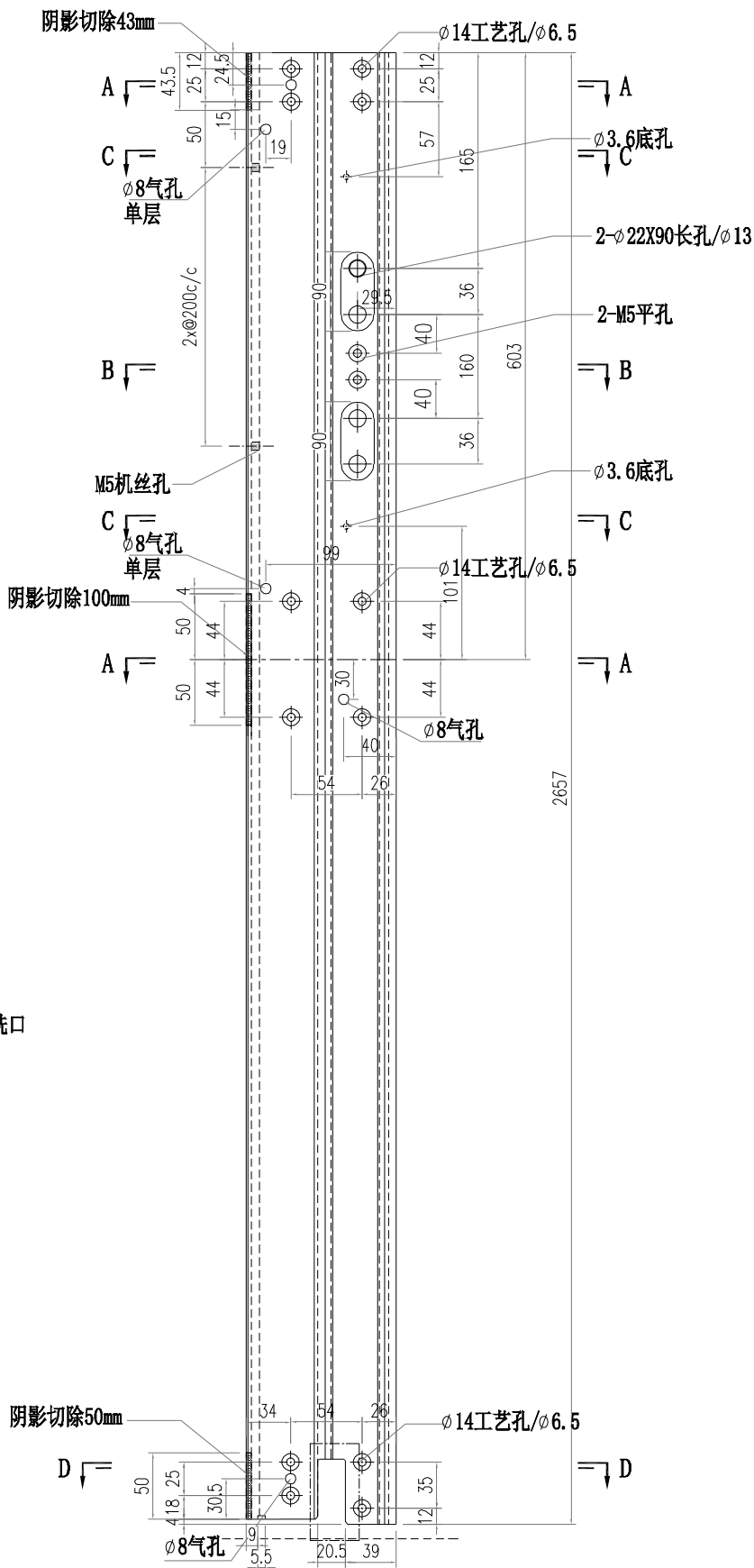
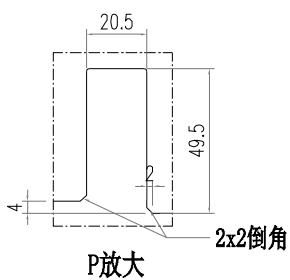
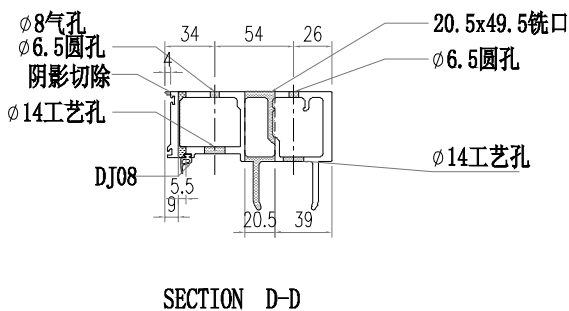
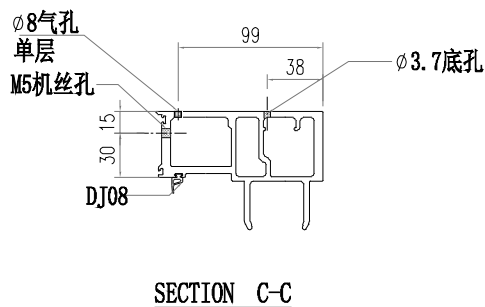
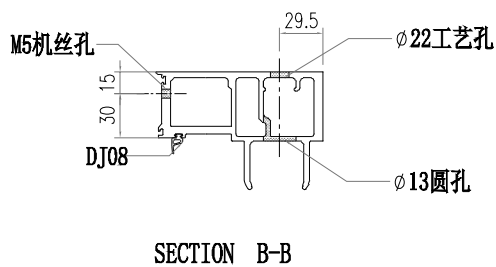
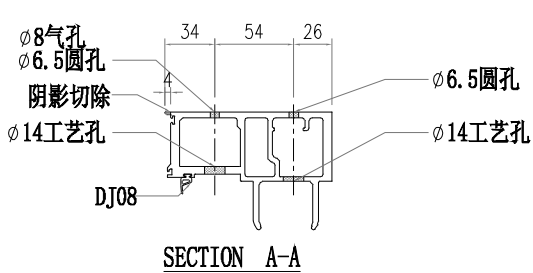

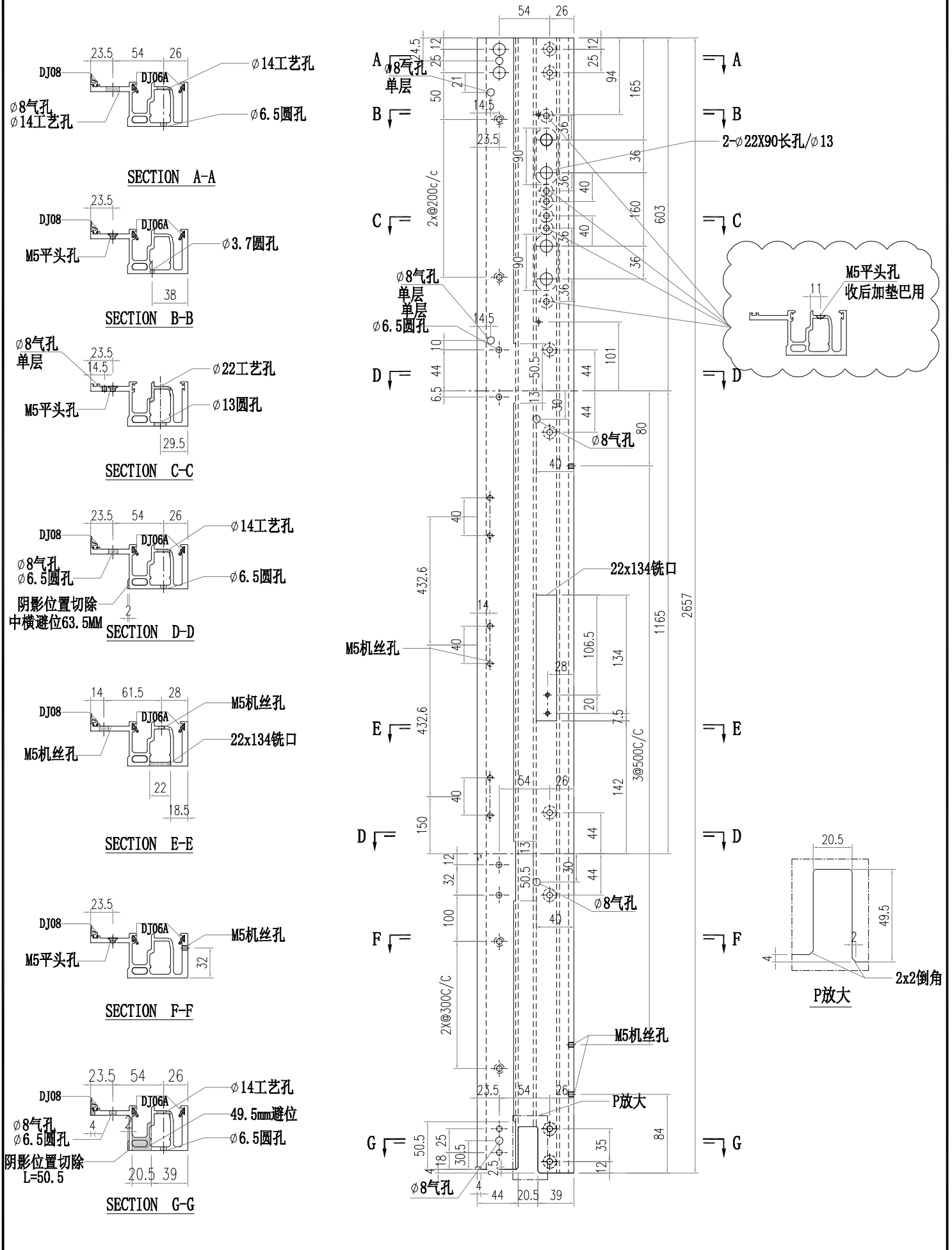

 美特铝质有限公司 MIDI Aluminium Fabricator Ltd.			工程號 J856 地盘 天榮站	類別 制圖 李傳鵬 復核 練松文 批准 林仁安	物料號 M1 2022-11-26 2022-11-27 2022-11-28	圖號 X86365-SU03 數量 - 單件重量 - (KG)
修改 日期	採用工廠 材料颜色 -UCT542919XL-3	地盤 <input checked="" type="checkbox"/>	图纸名称 铝料加工图 材料 X86365			

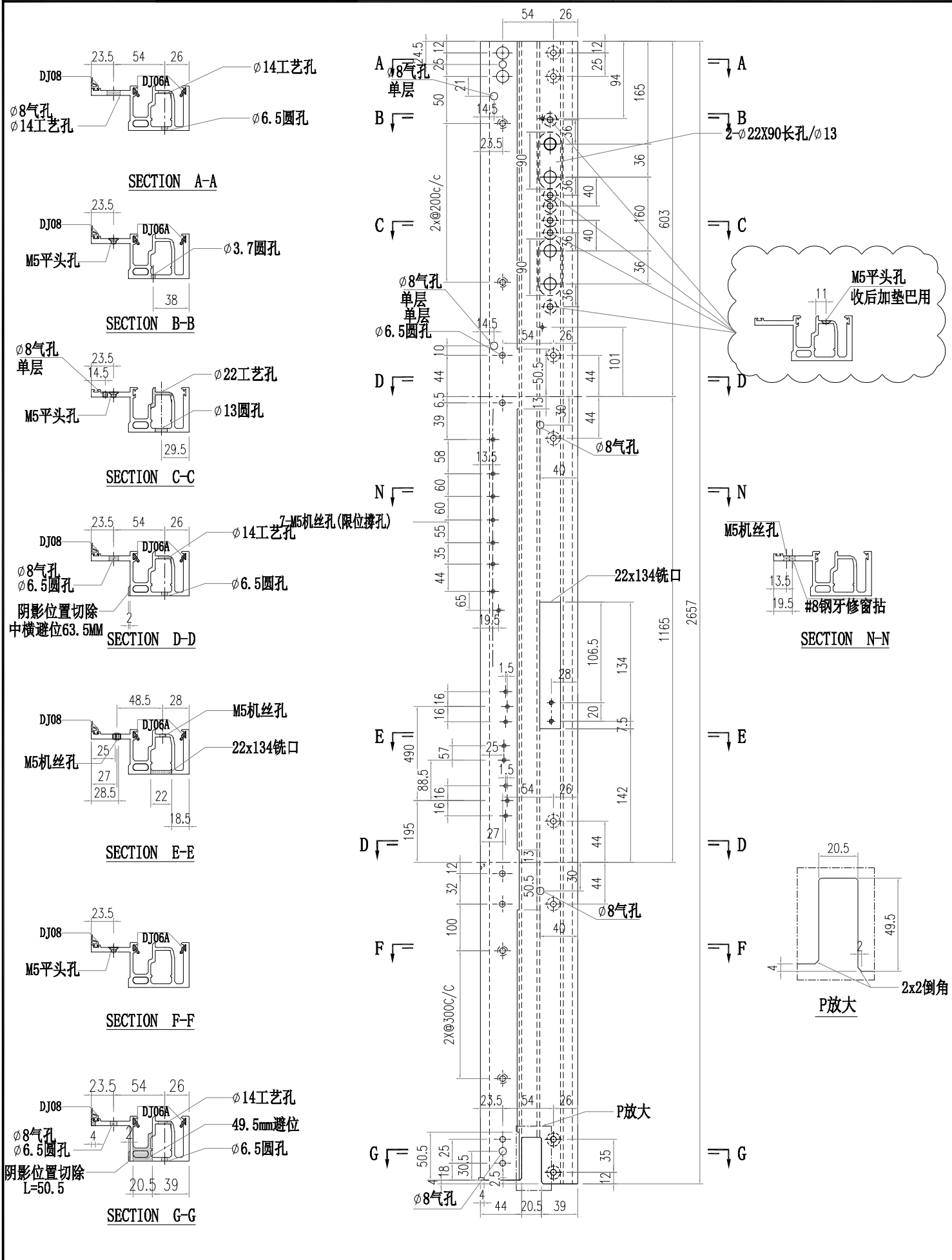

 美特铝质有限公司 MIDI Aluminium Fabricator Ltd.			工程號 J856 地盘 天榮站	類別 制圖 李傳鵬 復核 練松文 批准 林仁安	物料號 M1 2022-11-26 2022-11-27 2022-11-28	圖號 X86365-SU04 數量 - 單件重量 - (KG)
修改 日期	採用工廠 材料颜色 -UCT542919XL-3	地盤 <input checked="" type="checkbox"/>	图纸名称 铝料加工图 材料 X86365			

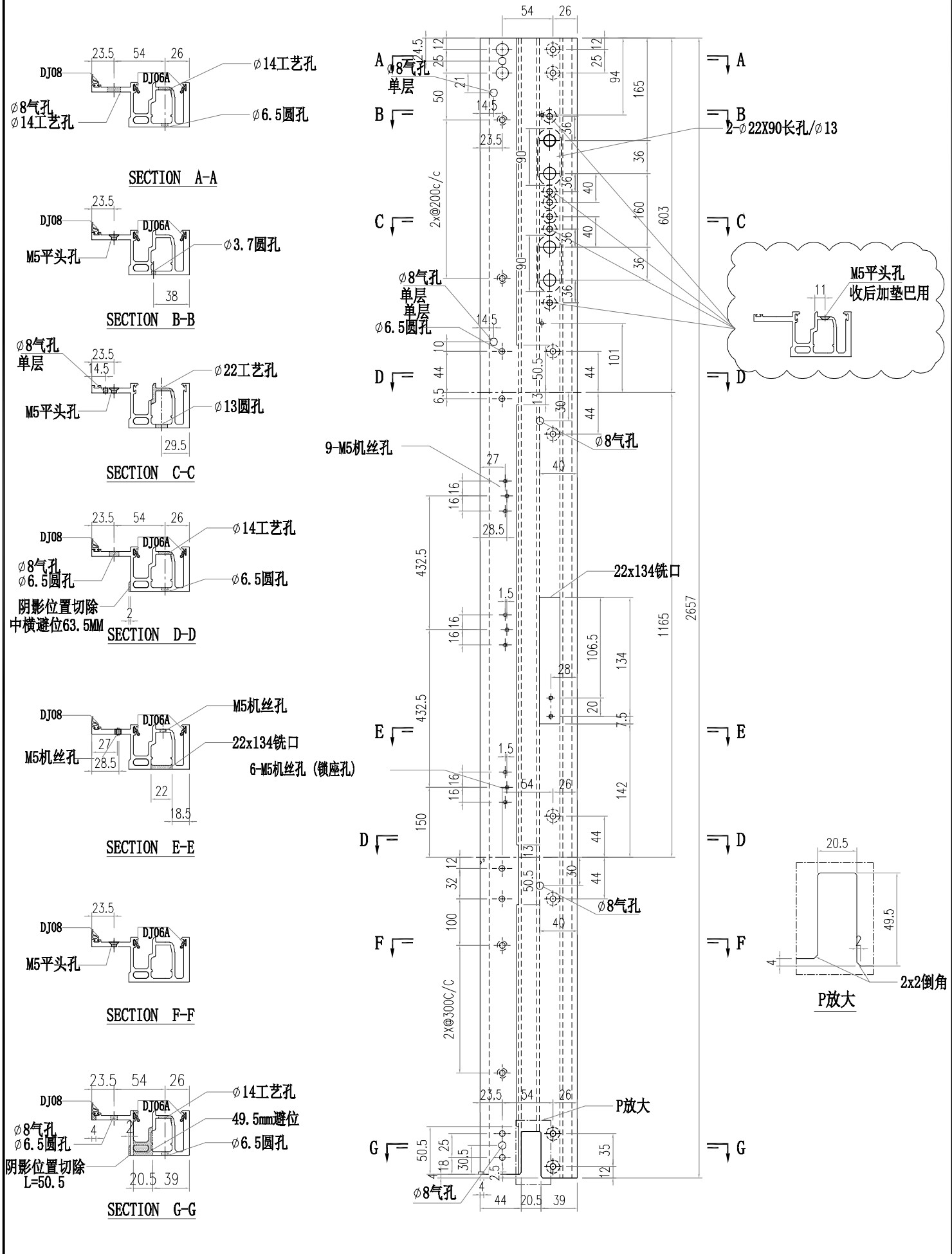

 美特鋁質有限公司 MIDI Aluminium Fabricator Ltd.		工程號 J856 地盘 天榮站	類別 制圖 李傳鵬 復核 練松文 批准 林仁安	物料號 M1 2022-11-26 2022-11-27 2022-11-28	圖號 AT01-SU01 數量 - 單件重量 - (KG)
修改 日期	採用工廠 材料颜色 -UCT542919XL-3	图纸名称 铝料加工图 材料 AT01			

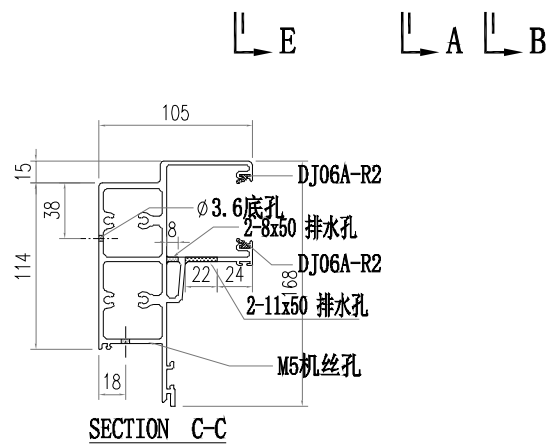
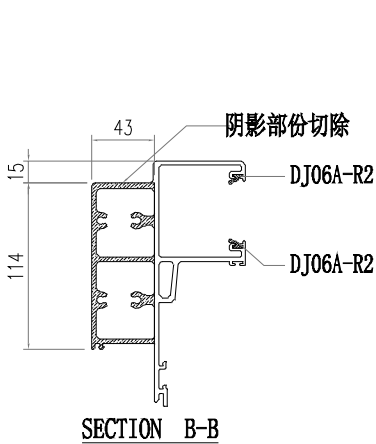
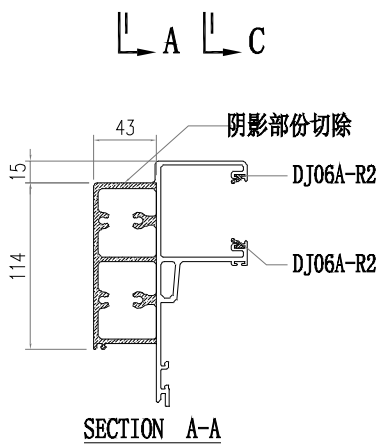
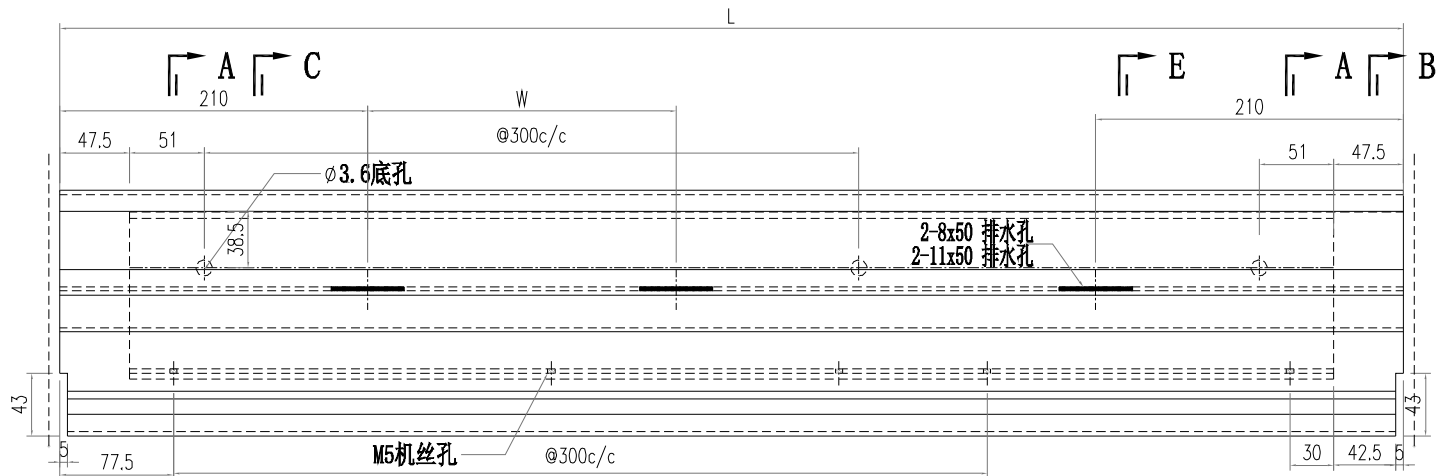
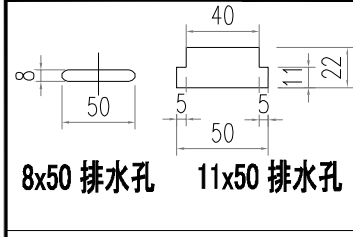

部件编号	L	分格尺寸	W
AT01-SU01-001	635	650	
AT01-SU01-002	1855	1870	3X478.3
AT01-SU01-003	1572.5	1587.5	1X576.3
AT01-SU01-004	870	885	
AT01-SU01-005	2185	2200	3X588.3
AT01-SU01-006	1392.5	1407.5	1X486.3
AT01-SU01-007	1572.5	1587.5	1X576.3
AT01-SU01-008	1955	1970	2X511.7
AT01-SU01-009	1305	1320	1X442.5
AT01-SU01-010	885	900	
AT01-SU01-011	1192.5	1207.5	

 美特鋁質有限公司 MIDI Aluminium Fabricator Ltd.		工程號 J856 地盘 天榮站	類別 制圖 李傳鵬 復核 練松文 批准 林仁安	物料號 M1 2022-11-26 2022-11-27 2022-11-28	圖號 AT01-SU02 數量 - 單件重量 - (KG)
修改 日期	採用工廠 材料颜色 -UCT542919XL-3	图纸名称 铝料加工图 材料 AT01			

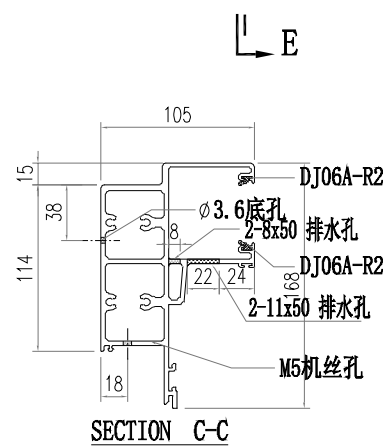
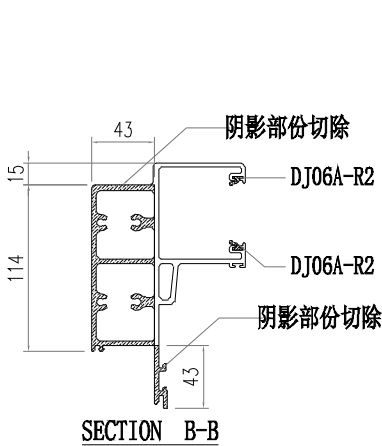
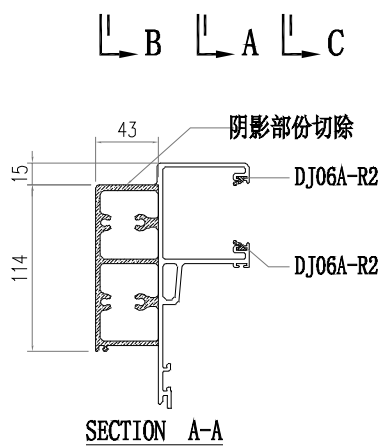
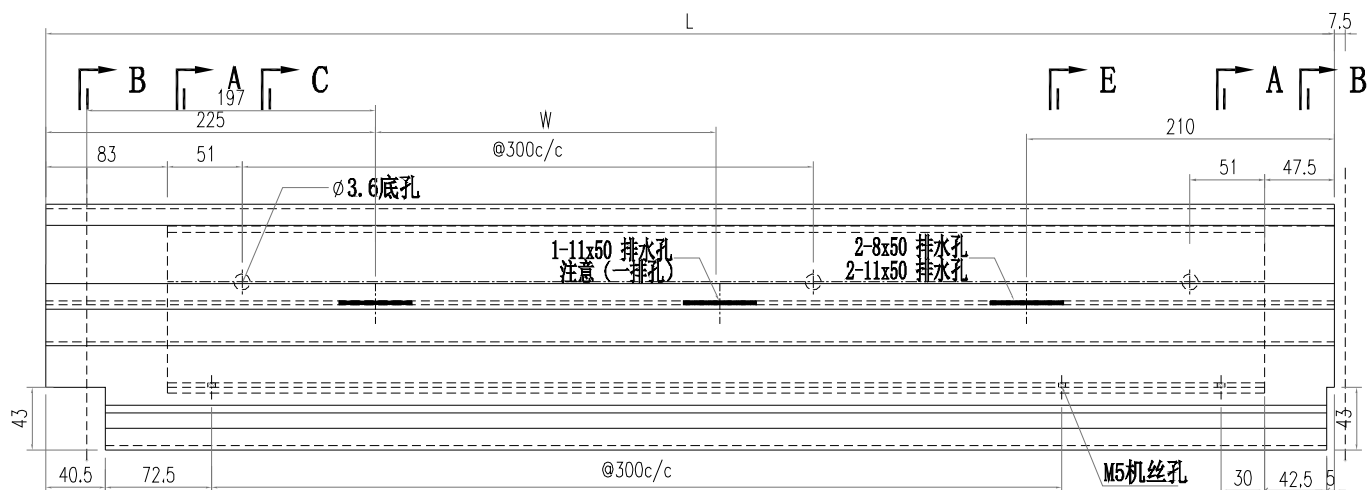
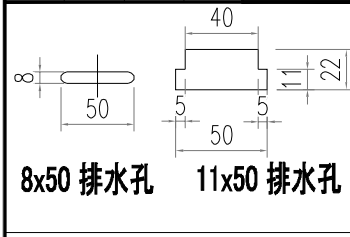

部件编号	L	分格尺寸	W
AT01-SU02-001	670.5	650	0
AT01-SU02-002	1428	1407.5	1X486.3
AT01-SU02-003	905.5	885	
AT01-SU02-004	940.5	920	

 美特鋁質有限公司 MIDI Aluminium Fabricator Ltd.		工程號 J856 地盘 天榮站	類別 制圖 李傳鵬 復核 練松文 批准 林仁安	物料號 M1 2022-11-26 2022-11-27 2022-11-28	圖號 AT01-SU03 數量 - 單件重量 - (KG)
修改 日期	採用工廠 材料颜色 -UCT542919XL-3	图纸名称 铝料加工图 材料 AT01			

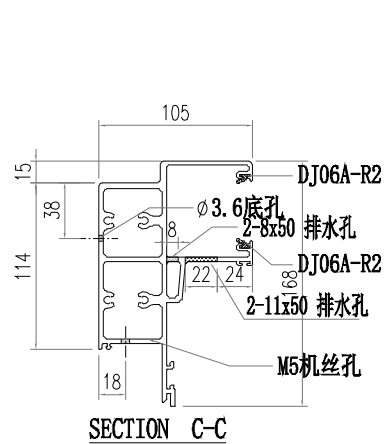
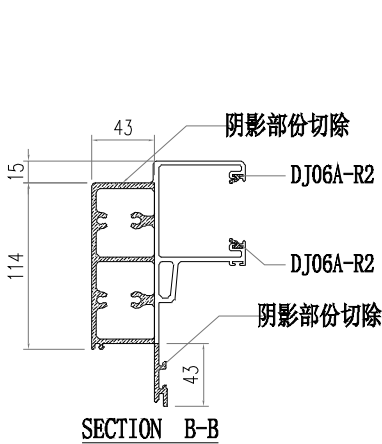
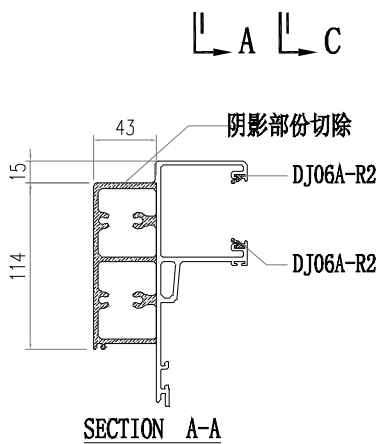
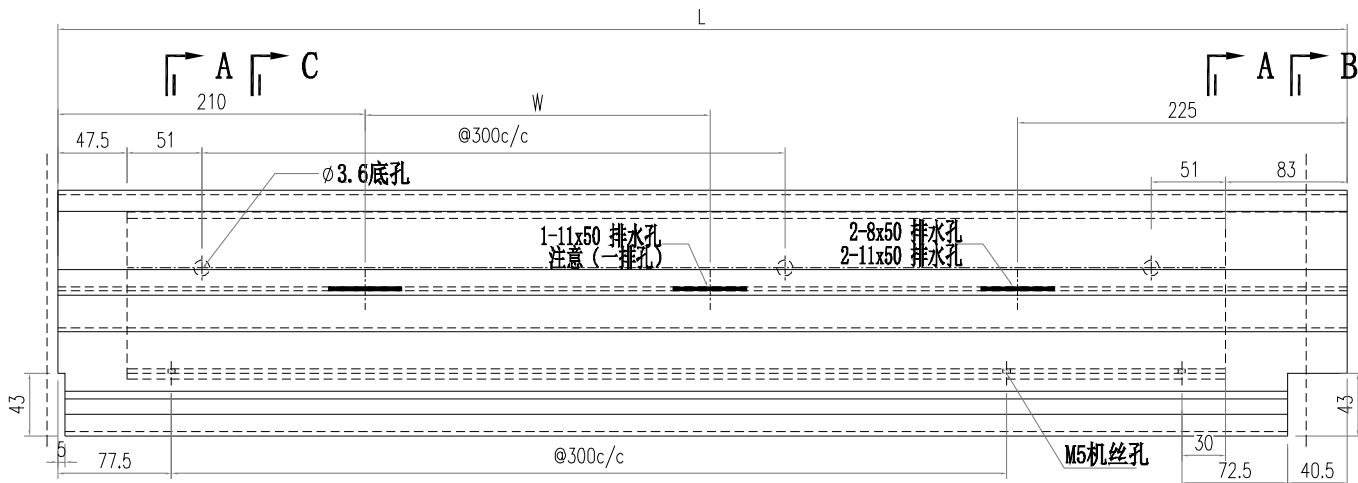
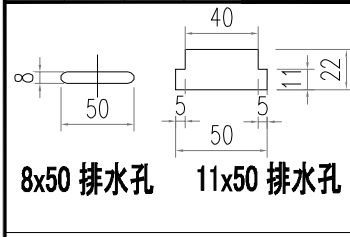

部件编号	L	分格尺寸	W
AT01-SU03-001	670.5	650	
AT01-SU03-002	905.5	885	
AT01-SU03-003	940.5	920	
AT01-SU03-004	920.5	900	

 美特鋁質有限公司 MIDI Aluminium Fabricator Ltd.				工程號 J856 地盘 天榮站	類別 制圖 李傳鵬 復核 練松文 批准 林仁安	物料號 M1 2022-11-26 2022-11-27 2022-11-28	圖號 AT04-SU01 數量 - 單件重量 - (KG)
修改 日期	採用工廠 材料颜色 -UCT542919XL-3	地盤 <input checked="" type="checkbox"/>	图纸名称 铝料加工图 材料 AT04				

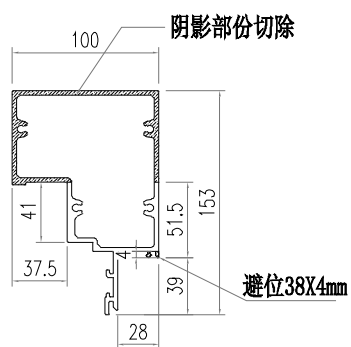
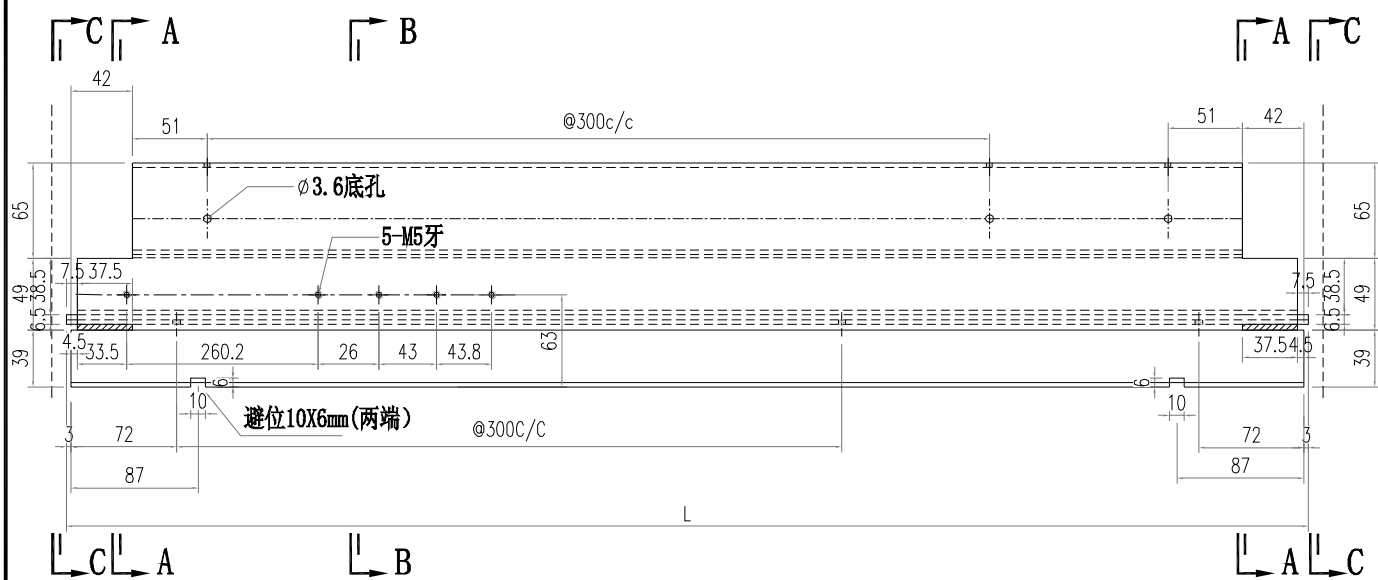

SECTION A-A

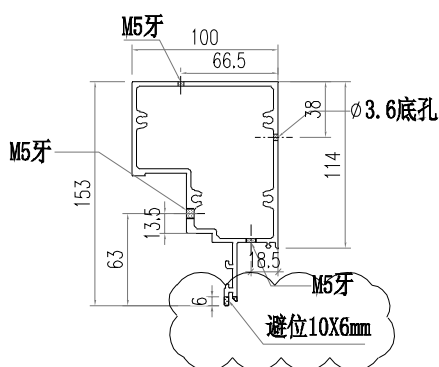

SECTION B-B

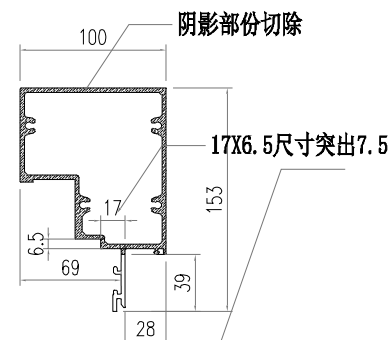

SECTION C-C

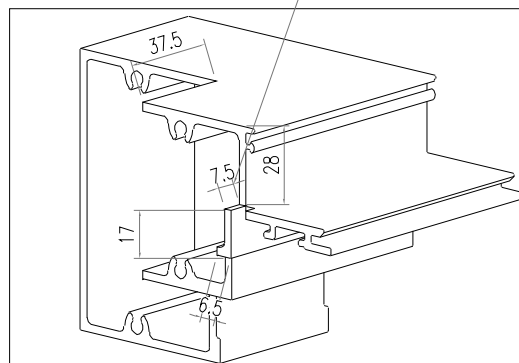

部件编号	L	分格尺寸
AT04-SU01-001	630	650

 美特鋁質有限公司 MIDI Aluminium Fabricator Ltd.		工程號 J856 地盘 天榮站	類別 制圖 李傳鵬 復核 練松文 批准 林仁安	物料號 M1 2022-11-26 2022-11-27 2022-11-28	圖號 AT04-SU02 數量 - 單件重量 - (KG)
修改 日期	採用工廠 材料颜色 -UCT542919XL-3	图纸名称 铝料加工图 材料 AT04			

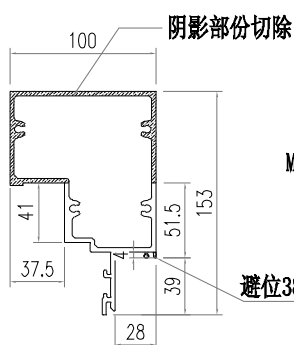
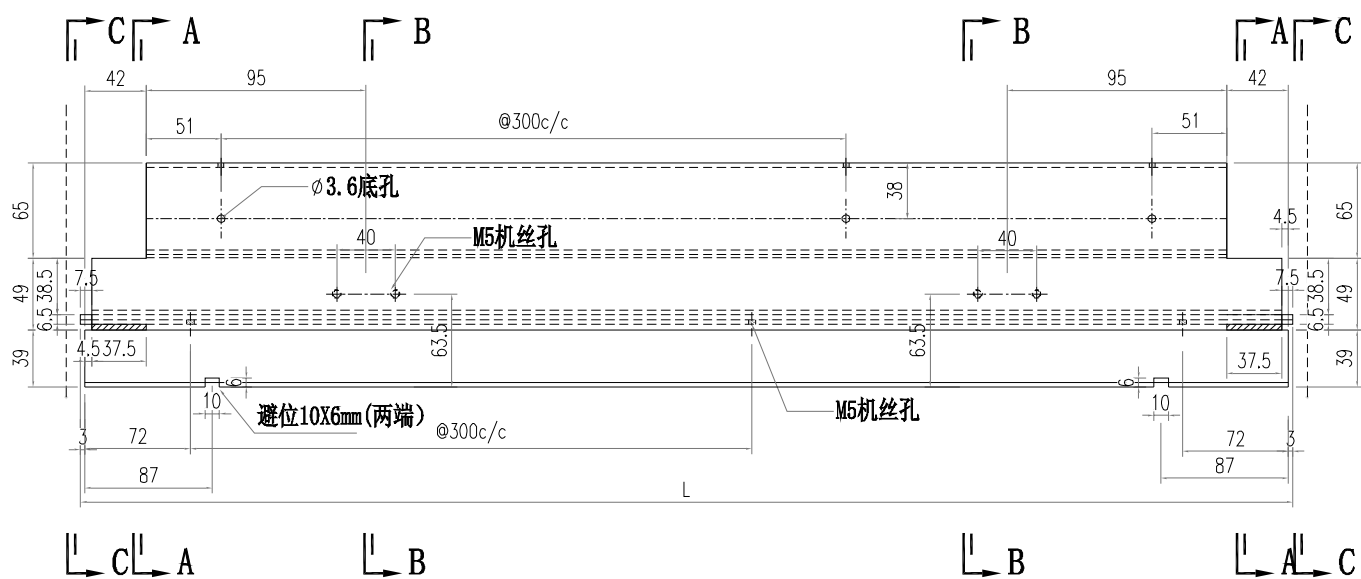

SECTION A-A

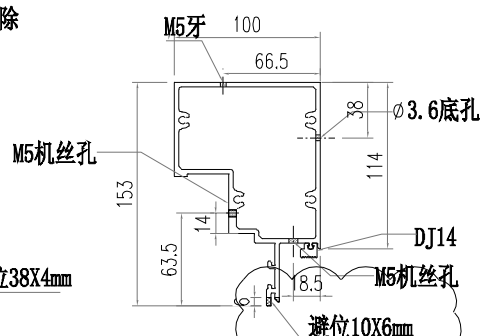

SECTION B-B

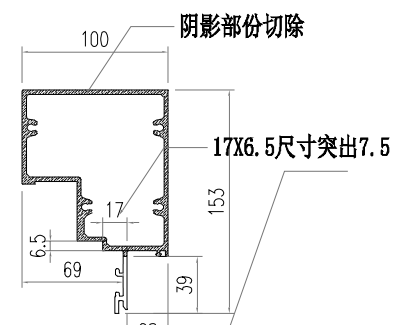

SECTION C-C

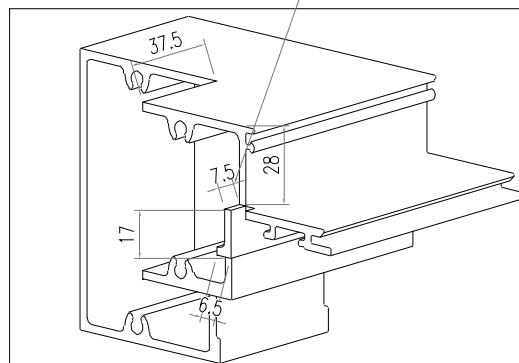

部件编号	L	分格尺寸
AT04-SU02-001	630	650
AT04-SU02-002	865	885
AT04-SU02-003	900	920
AT04-SU02-004	880	900

 美特鋁質有限公司 MIDI Aluminium Fabricator Ltd.				工程號 J856 地盘 天榮站	類別 制圖 李傳鵬 復核 練松文 批准 林仁安	物料號 M1 圖號 AT05-SU01 數量 - 單件重量 - (KG)
修改日期	採用工廠	地盘 <input checked="" type="checkbox"/>	图纸名称 铝料加工图	材料 AT05	日期 2022-11-26 2022-11-27 2022-11-28	圖號 AT05-SU01 數量 - 單件重量 - (KG)
		材料颜色 -UCT542919XL-3				

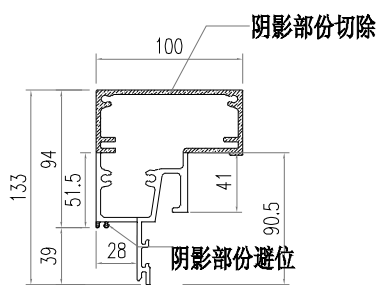
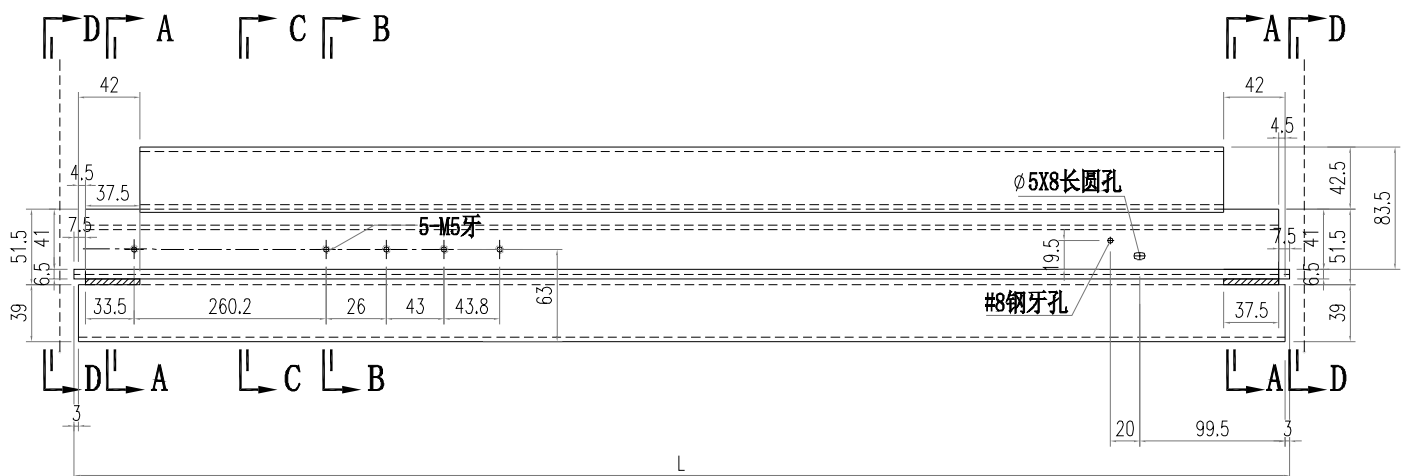
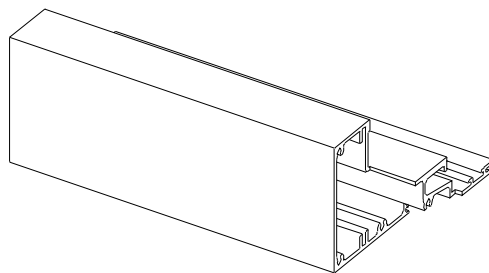

SECTION A-A

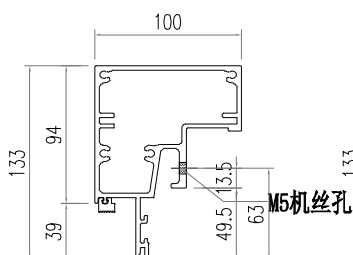

SECTION B-B

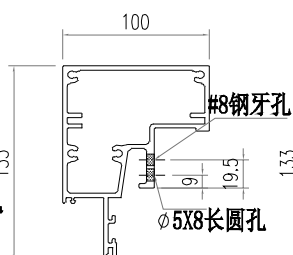

SECTION C-C

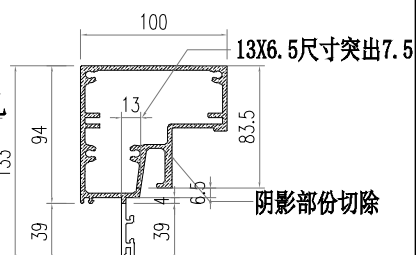

SECTION D-D

部件编号	L	分格尺寸
AT05-SU01-001	630	650

 美特鋁質有限公司 MIDI Aluminium Fabricator Ltd.		工程號 J856 地盘 天榮站	類別 制圖 李傳鵬 復核 練松文 批准 林仁安	物料號 M1 2022-11-26 2022-11-27 2022-11-28	圖號 AT05-SU02 數量 - 單件重量 - (KG)
修改 日期	採用工廠 材料颜色 -UCT542919XL-3	图纸名称 铝料加工图 材料 AT05			

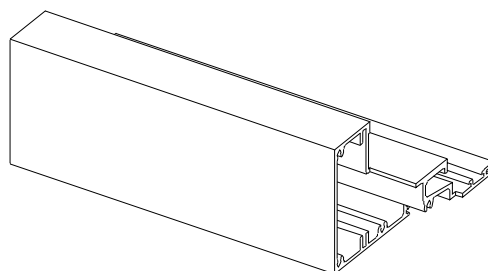

3D VIEW

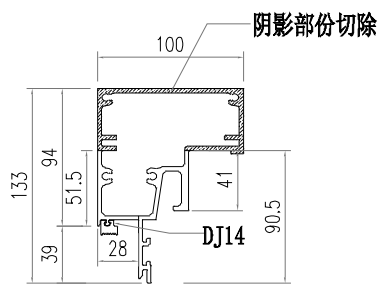
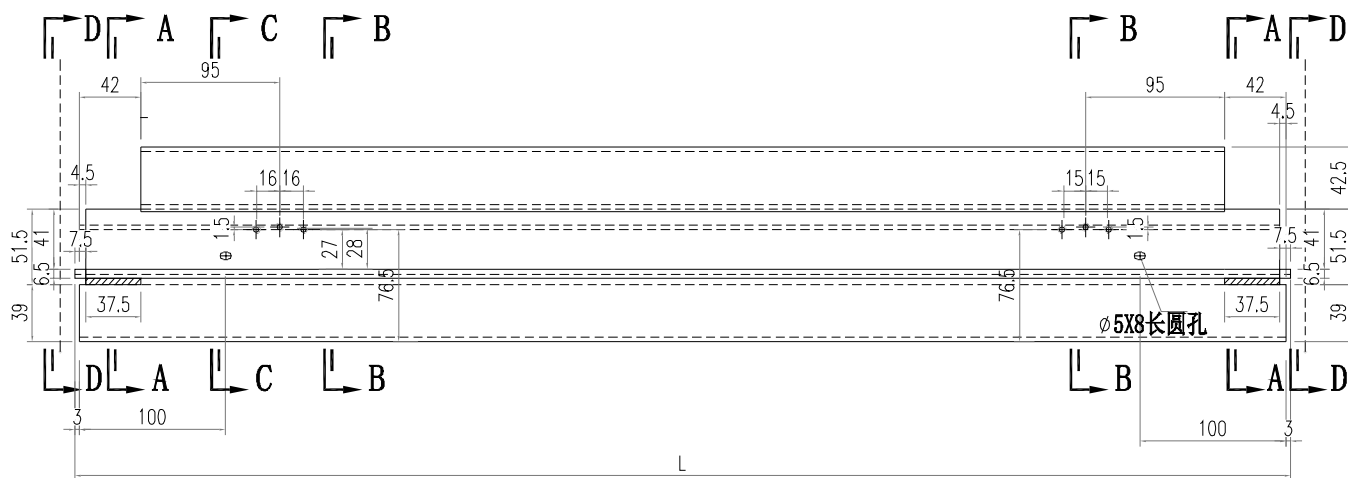

SECTION A-A

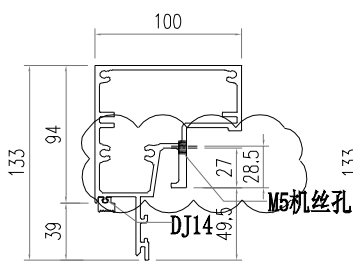

SECTION B-B

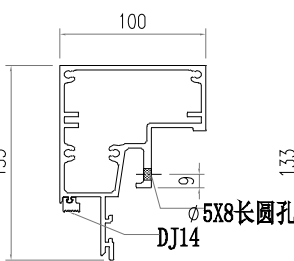

SECTION C-C

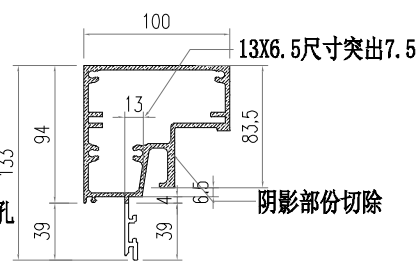

SECTION D-D

部件编号	L	分格尺寸
AT05-SU02-001	630	650
AT05-SU02-002	865	885
AT05-SU02-003	900	920
AT05-SU02-004	880	900

 美特鋁質有限公司 MIDI Aluminium Fabricator Ltd.			工程號 J856 地盘 天榮站	類別 制圖 李傳鵬 復核 練松文 批准 林仁安	物料號 M1 2022-11-26 2022-11-27 2022-11-28	圖號 AT05-SU03 數量 - 單件重量 - (KG)	
修改 日期	採用工廠 材料颜色 -UCT542919XL-3	地盤 <input checked="" type="checkbox"/>	图纸名称 铝料加工图 材料 AT05				

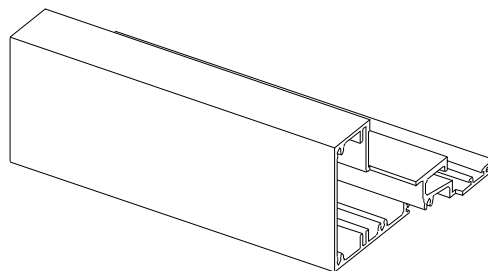

3D VIEW

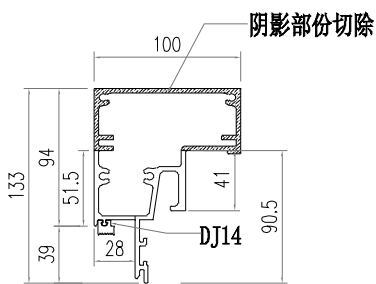
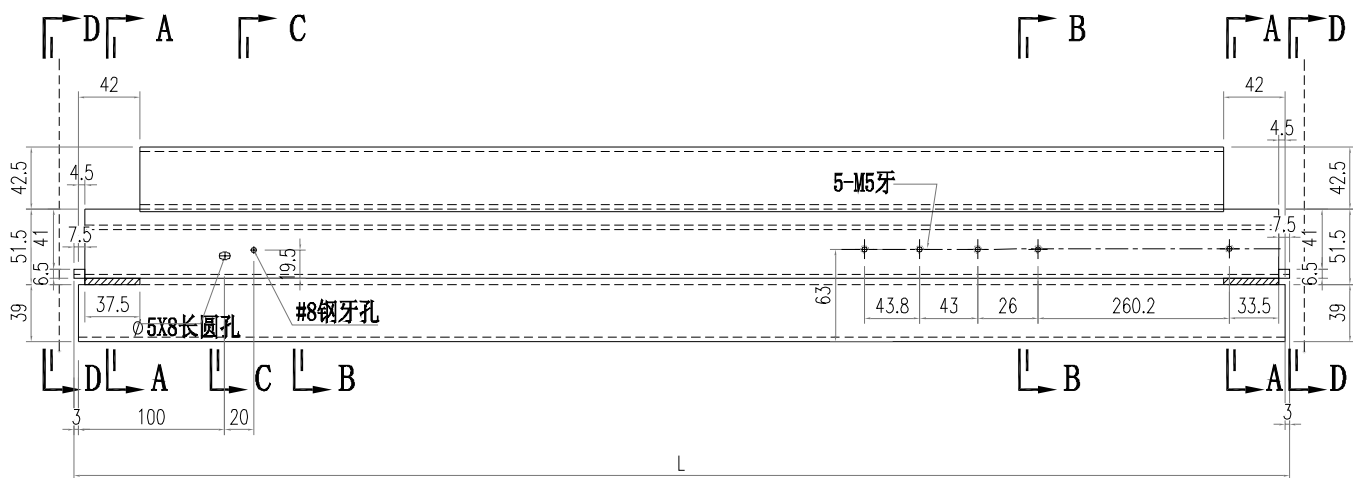

SECTION A-A

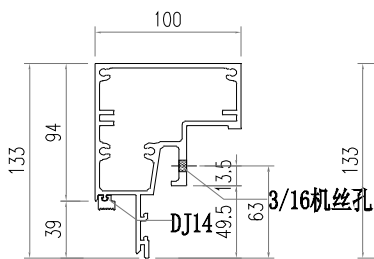

SECTION B-B

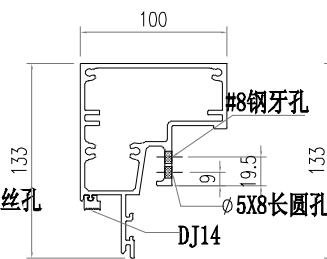

SECTION C-C

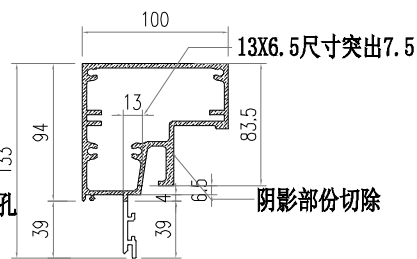

SECTION D-D

部件编号	L	分格尺寸
AT05-SU03-001	630	650

 美特鋁質有限公司 MIDI Aluminium Fabricator Ltd.				工程號 J856	類別 天榮站	物料號 M1	圖號 AT03-SU01
修改 日期	採用工廠 地盤 <input checked="" type="checkbox"/>	图纸名称 铝料加工图	材料 AT03	制圖 李傳鵬	2022-11-26	數量 -	單件重量 - (KG)
	材料颜色 -UCT542919XL-3			復核 練松文	2022-11-27		
				批准 林仁安	2022-11-28		

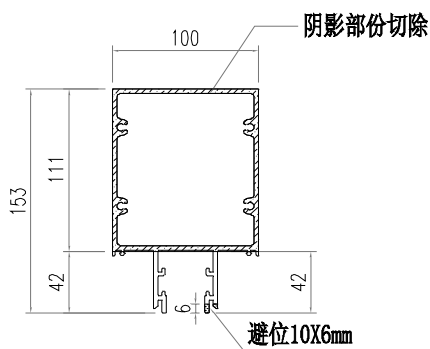
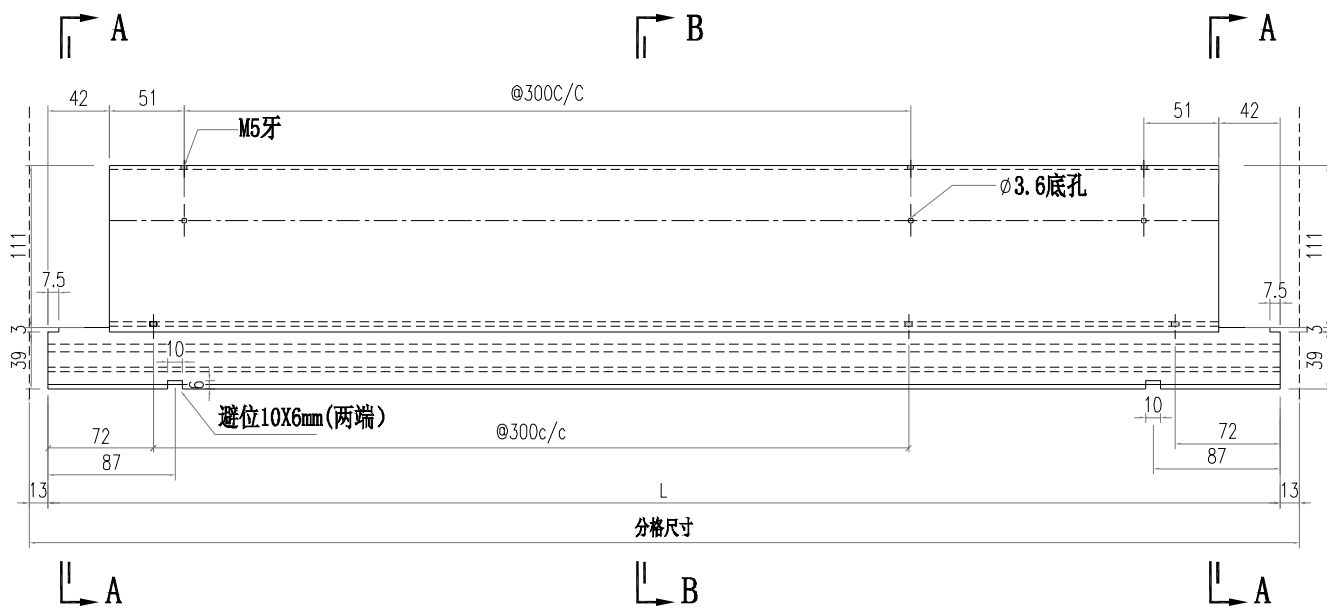

SECTION A-A

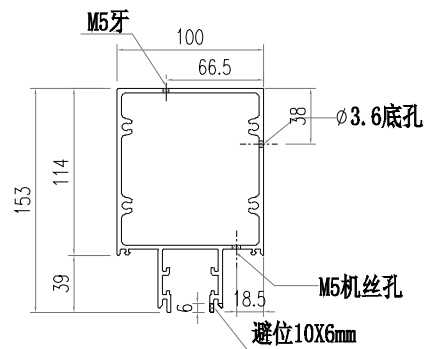

SECTION B-B

部件编号	L	分格尺寸
AT03-SU01-001	1844	1870
AT03-SU01-002	1561.5	1587.5
AT03-SU01-003	2174	2200
AT03-SU01-004	1381.5	1407.5
AT03-SU01-005	1561.5	1587.5
AT03-SU01-006	1944	1970
AT03-SU01-007	1294	1320
AT03-SU01-008	1181.5	1207.5

 美特鋁質有限公司 MIDI Aluminium Fabricator Ltd.				工程號 J856	類別 天榮站	物料號 M1	圖號 AT02-SU01
修改 日期	採用工廠 地盤 <input checked="" type="checkbox"/>	圖紙名稱 鋁料加工圖	材料 AT02	制圖 李傳鵬	復核 練松文	數量 -	單件重量 - (KG)
	材料顏色 -UCT542919XL-3			2022-11-26	2022-11-27	2022-11-28	

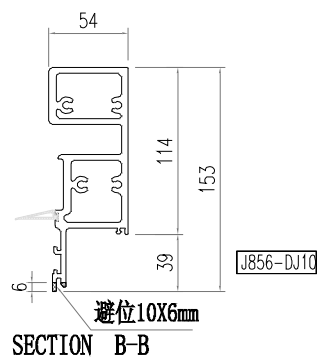
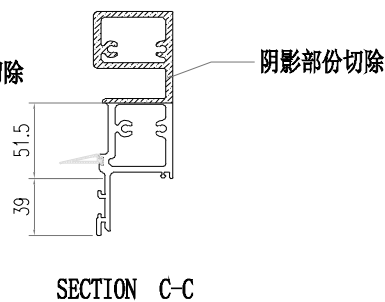
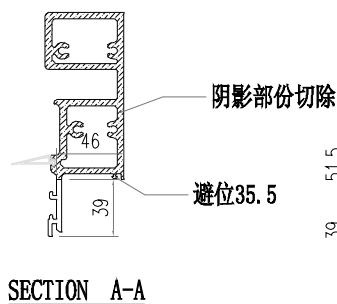
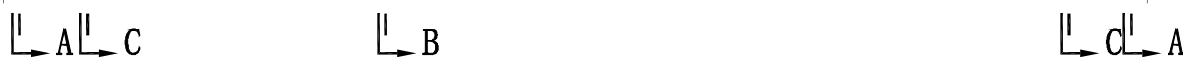
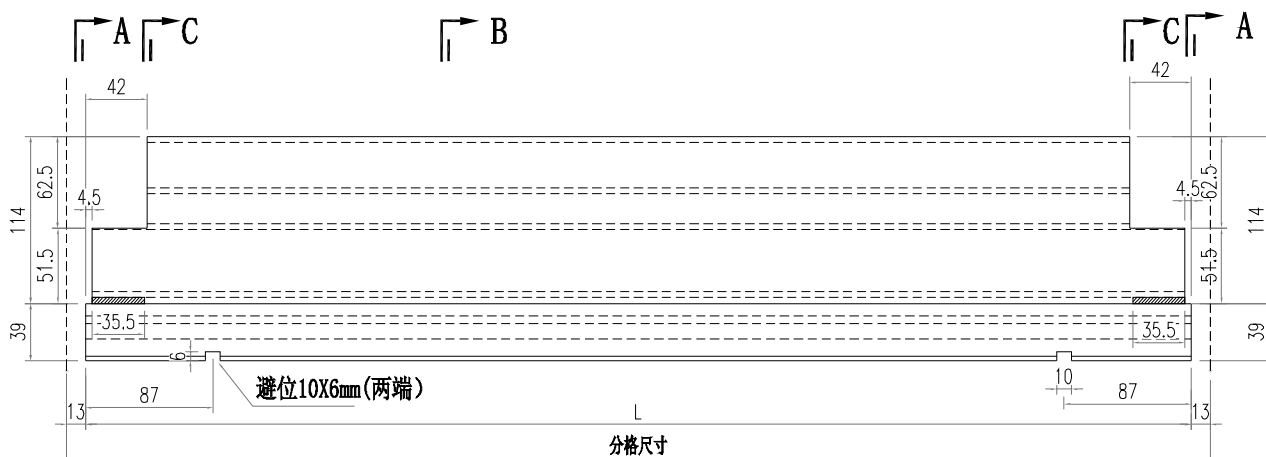

部件编号	L	分格尺寸
AT02-SU01-001	624	650
AT02-SU01-002	859	885
AT02-SU01-003	894	920
AT02-SU01-004	874	900

 美特鋁質有限公司 MIDI Aluminium Fabricator Ltd.				工程號 J856	類別 天榮站	物料號 M1	圖號 AT02-SU02	
修改 日期	採用 工廠	地盤 <input checked="" type="checkbox"/>	圖紙名稱 鋁料加工圖	制圖 李傳鵬	2022-11-26	數量 -	單件重量 - (KG)	
	材料顏色 -UCT542919XL-3		材料 AT02	復核 練松文	2022-11-27	數量 -	單件重量 - (KG)	
				批准 林仁安	2022-11-28	數量 -	單件重量 - (KG)	

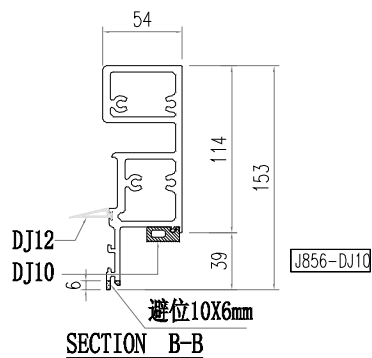
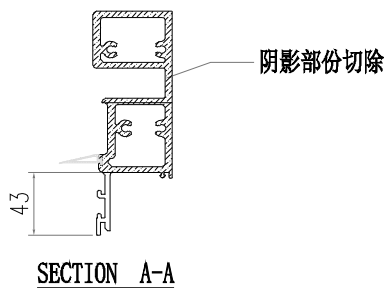
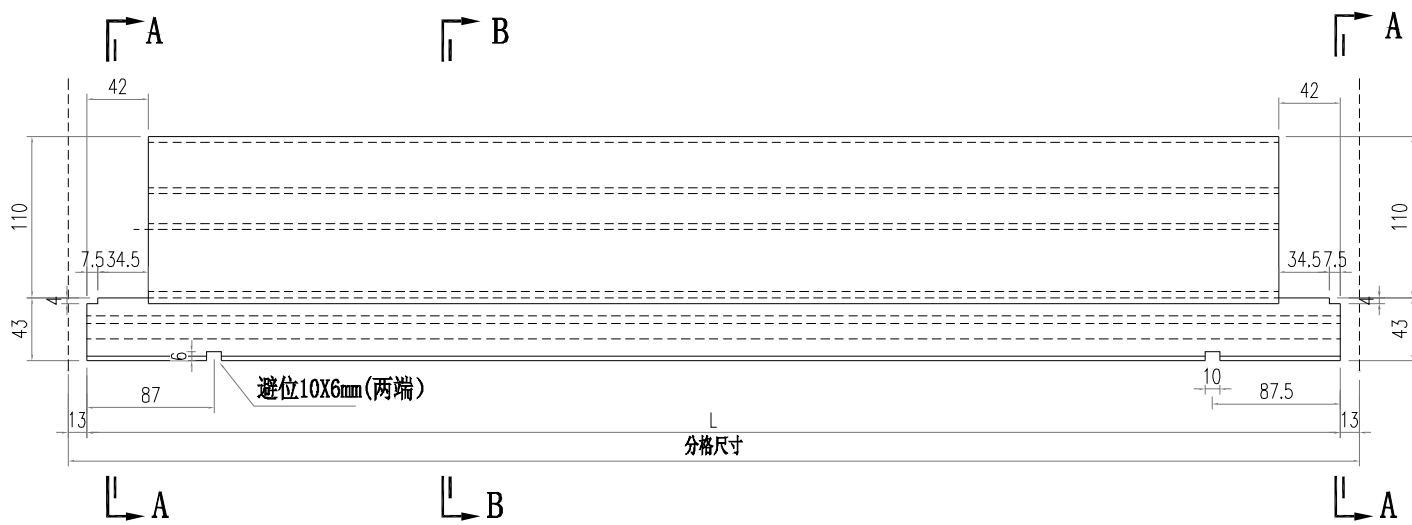

部件编号	L	分格尺寸
AT02-SU02-001	1844	1870
AT02-SU02-002	1561.5	1587.5
AT02-SU02-003	2174	2200
AT02-SU02-004	1381.5	1407.5
AT02-SU02-005	1561.5	1587.5
AT02-SU02-006	1944	1970
AT02-SU02-007	1294	1320
AT02-SU02-008	1181.5	1207.5

 美特鋁質有限公司 MIDI Aluminium Fabricator Ltd.			工程號 J856 地盘 天榮站	類別 制圖 李傳鵬 復核 練松文 批准 林仁安	物料號 M1 2022-11-26 2022-11-27 2022-11-28	圖號 AD06-T07 數量 - 單件重量 - (KG)
修改 日期	採用工廠 材料颜色 -UCT542919XL-3	地盘 <input checked="" type="checkbox"/>	图纸名称 铝料加工图 材料 AD06			

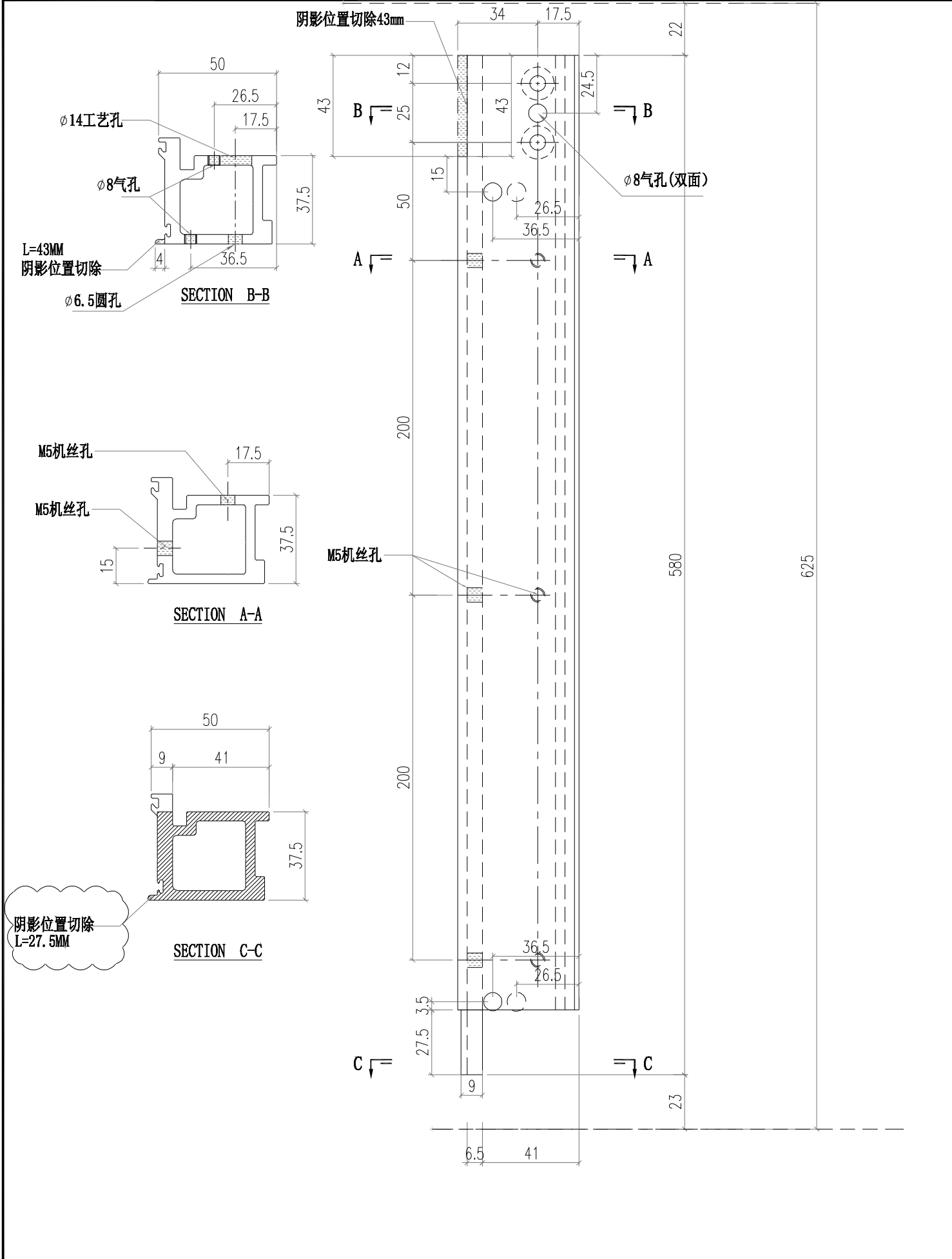

 美特鋁質有限公司 MIDI Aluminium Fabricator Ltd.		工程號 J856 地盘 天榮站	類別 制圖 李傳鵬 復核 練松文 批准 林仁安	物料號 M1 2022-11-26 2022-11-27 2022-11-28	圖號 AD06-P01 數量 - 單件重量 - (KG)
修改 日期	採用工廠 材料颜色 -UCT542919XL-3	图纸名称 铝料加工图 材料 AD06			

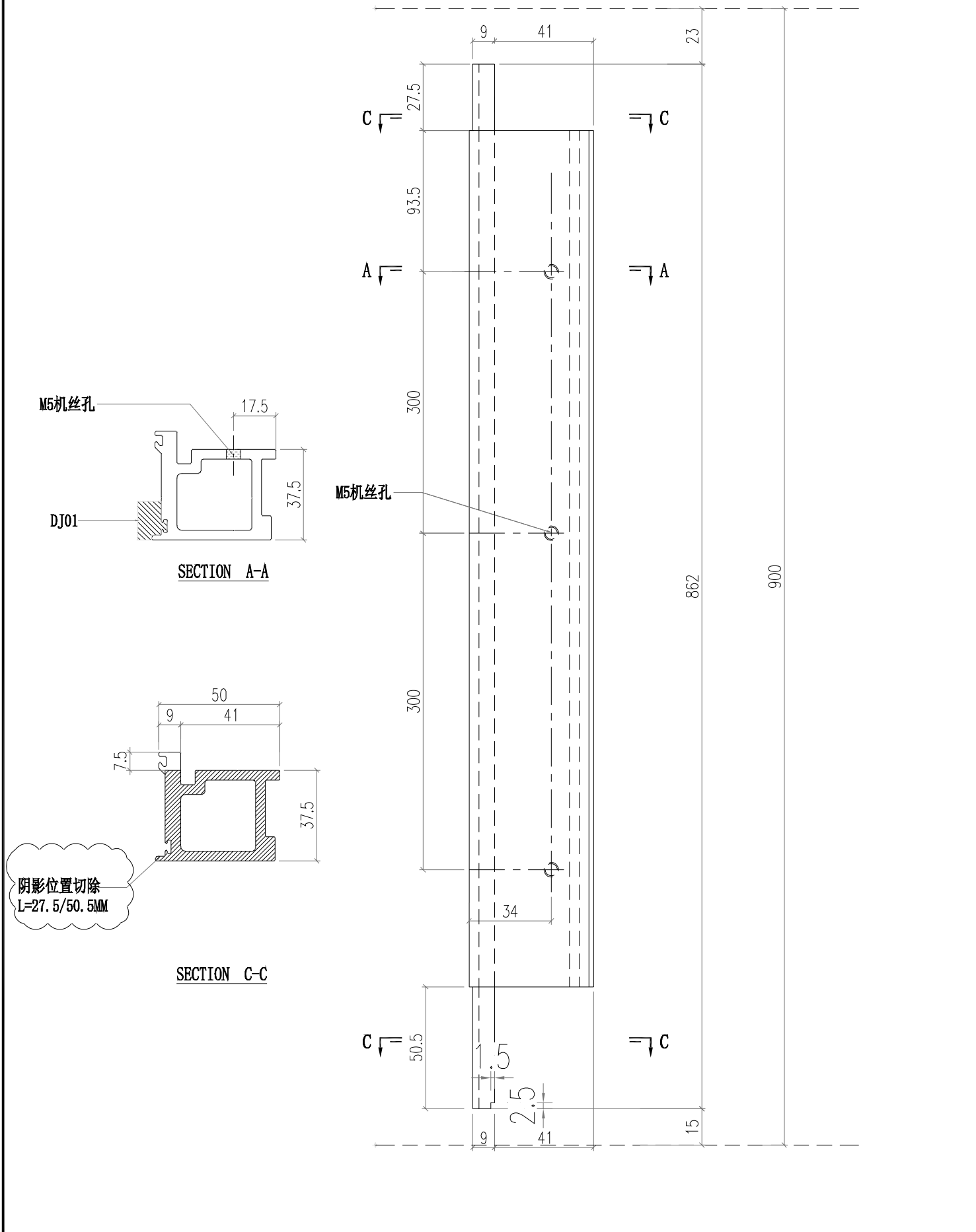

 美特鋁質有限公司 MIDI Aluminium Fabricator Ltd.			工程號 J856 地盘 天榮站	類別 制圖 李傳鵬 復核 練松文 批准 林仁安	物料號 M1 2022-11-26 2022-11-27 2022-11-28	圖號 AD06-T08 數量 - 單件重量 - (KG)
修改 日期	採用工廠 材料颜色 -UCT542919XL-3	地盘 <input checked="" type="checkbox"/>	图纸名称 铝料加工图 材料 AD06			

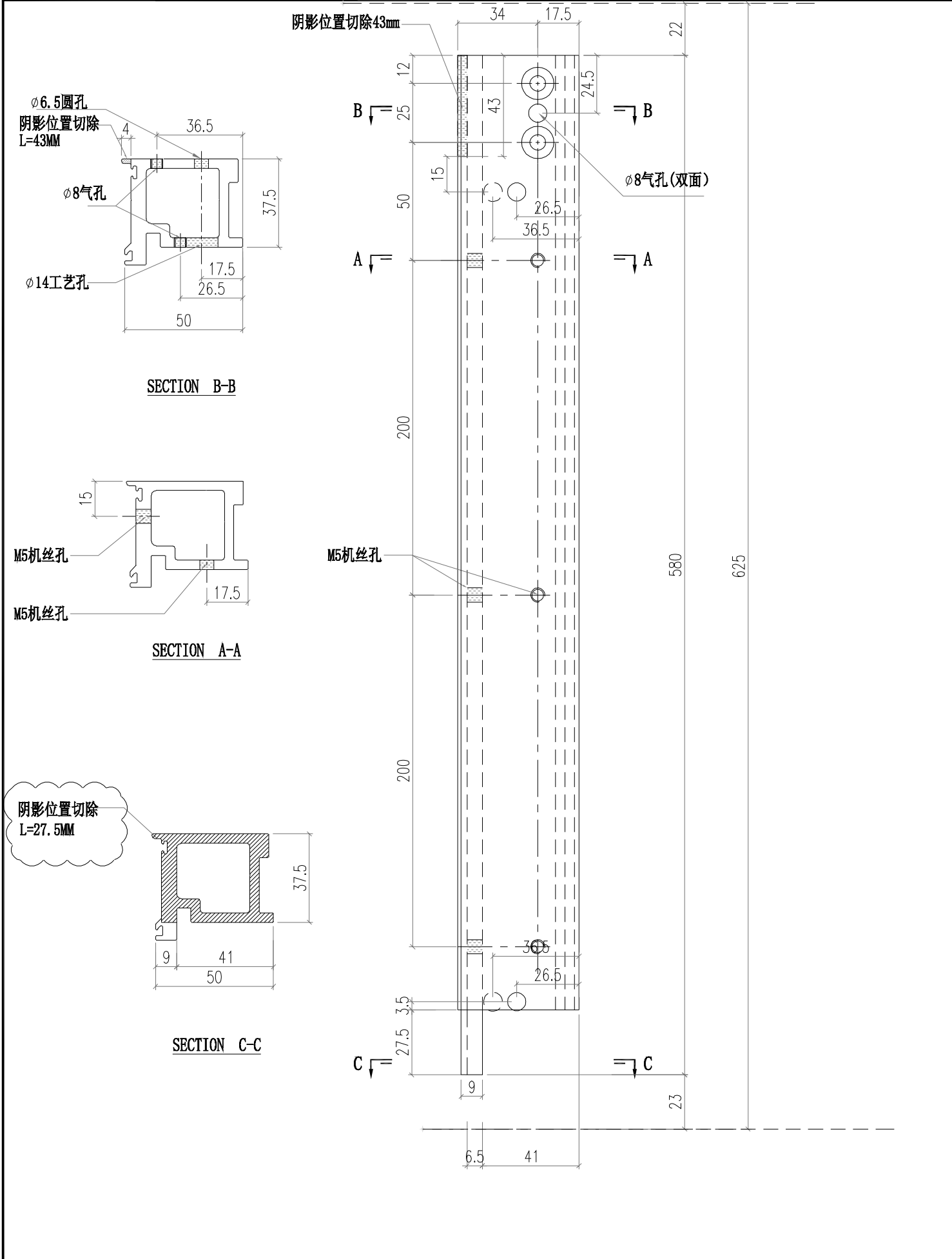

 美特鋁質有限公司 MIDI Aluminium Fabricator Ltd.				工程號 J856 地盘 天榮站	類別 制圖 李傳鵬 復核 練松文 批准 林仁安	物料號 M1 2022-11-26 2022-11-27 2022-11-28	圖號 AD06-P02 數量 - 單件重量 - (KG)
修改 日期	採用工廠 材料颜色 -UCT542919XL-3	地盤 <input checked="" type="checkbox"/>	图纸名称 铝料加工图 材料 AD06				

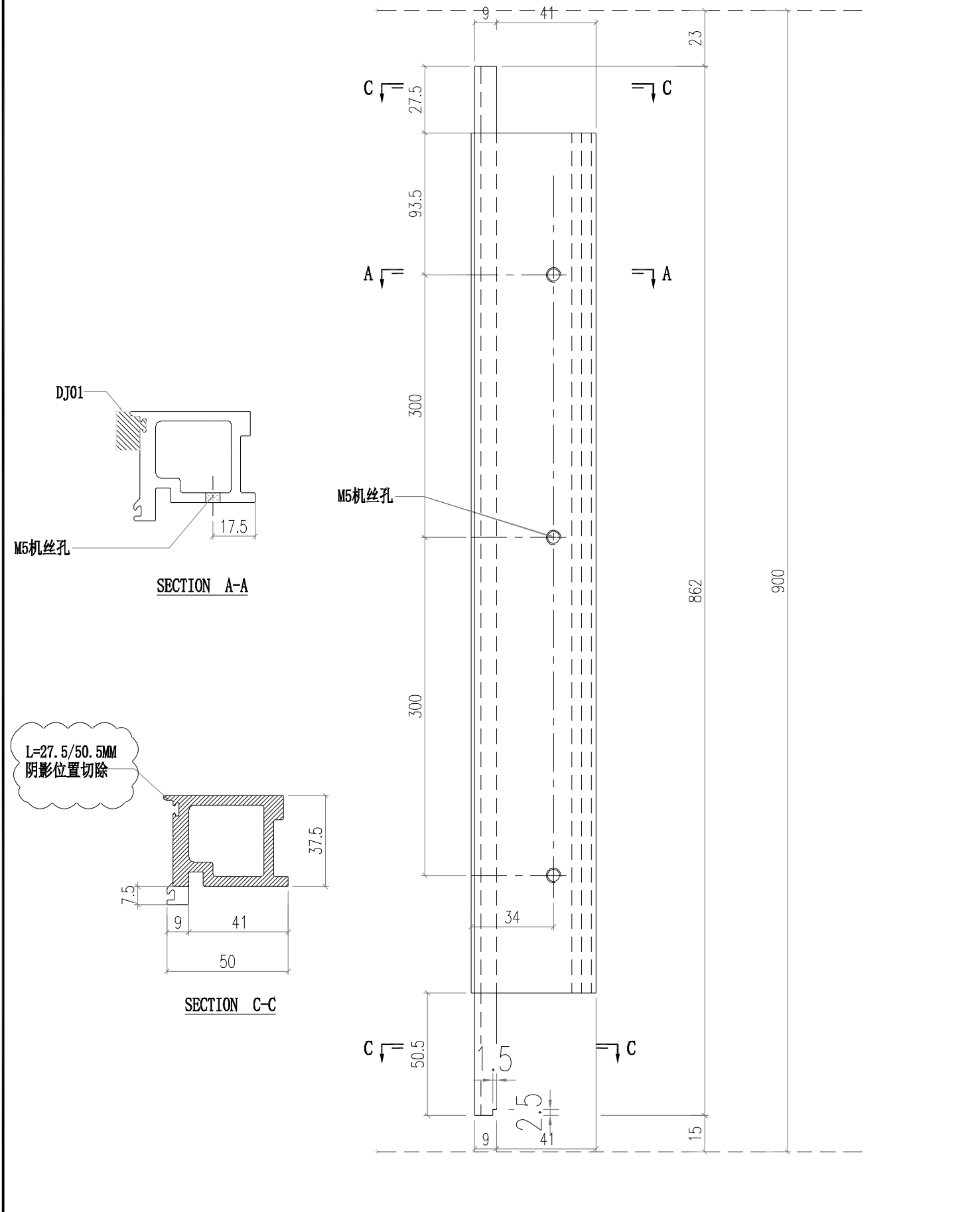

 美特鋁質有限公司 MIDI Aluminium Fabricator Ltd.		工程號 J856 地盘 天榮站	類別 制圖 李傳鵬 復核 練松文 批准 林仁安	物料號 M1 2022-11-26 2022-11-27 2022-11-28	圖號 X86371-T03 數量 - 單件重量 - (KG)
修改 日期	採用工廠 材料颜色 -UCT542919XL-3	图纸名称 铝料加工图 材料 X86371			

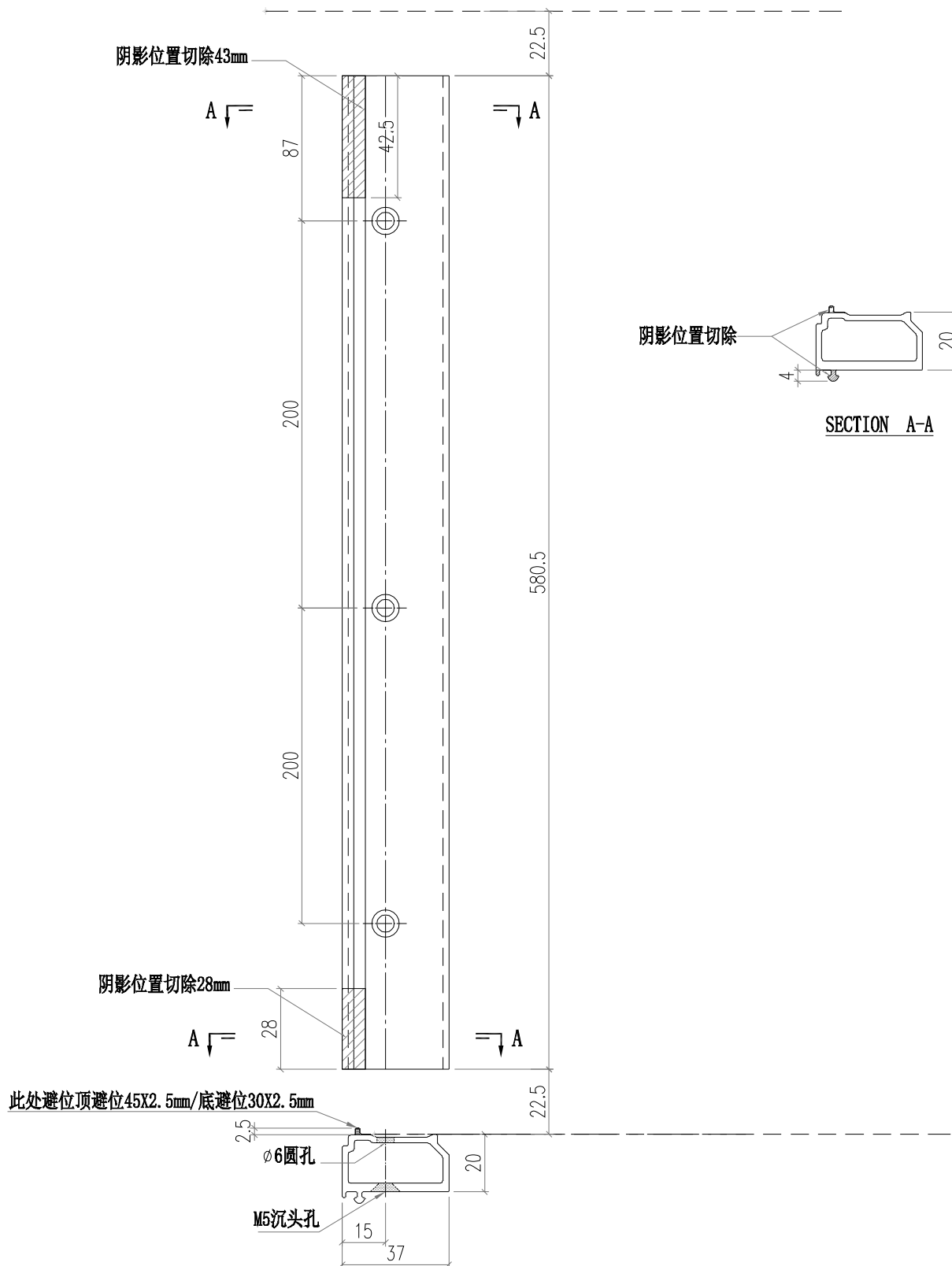

 美特鋁質有限公司 MIDI Aluminium Fabricator Ltd.				工程號 J856 地盘 天榮站	類別 制圖 李傳鵬 復核 練松文 批准 林仁安	物料號 M1 2022-11-26 2022-11-27 2022-11-28	圖號 X86371-T04 數量 - 單件重量 - (KG)
修改 日期	採用工廠 材料颜色 -UCT542919XL-3	地盤 <input checked="" type="checkbox"/>	图纸名称 铝料加工图 材料 X86371				

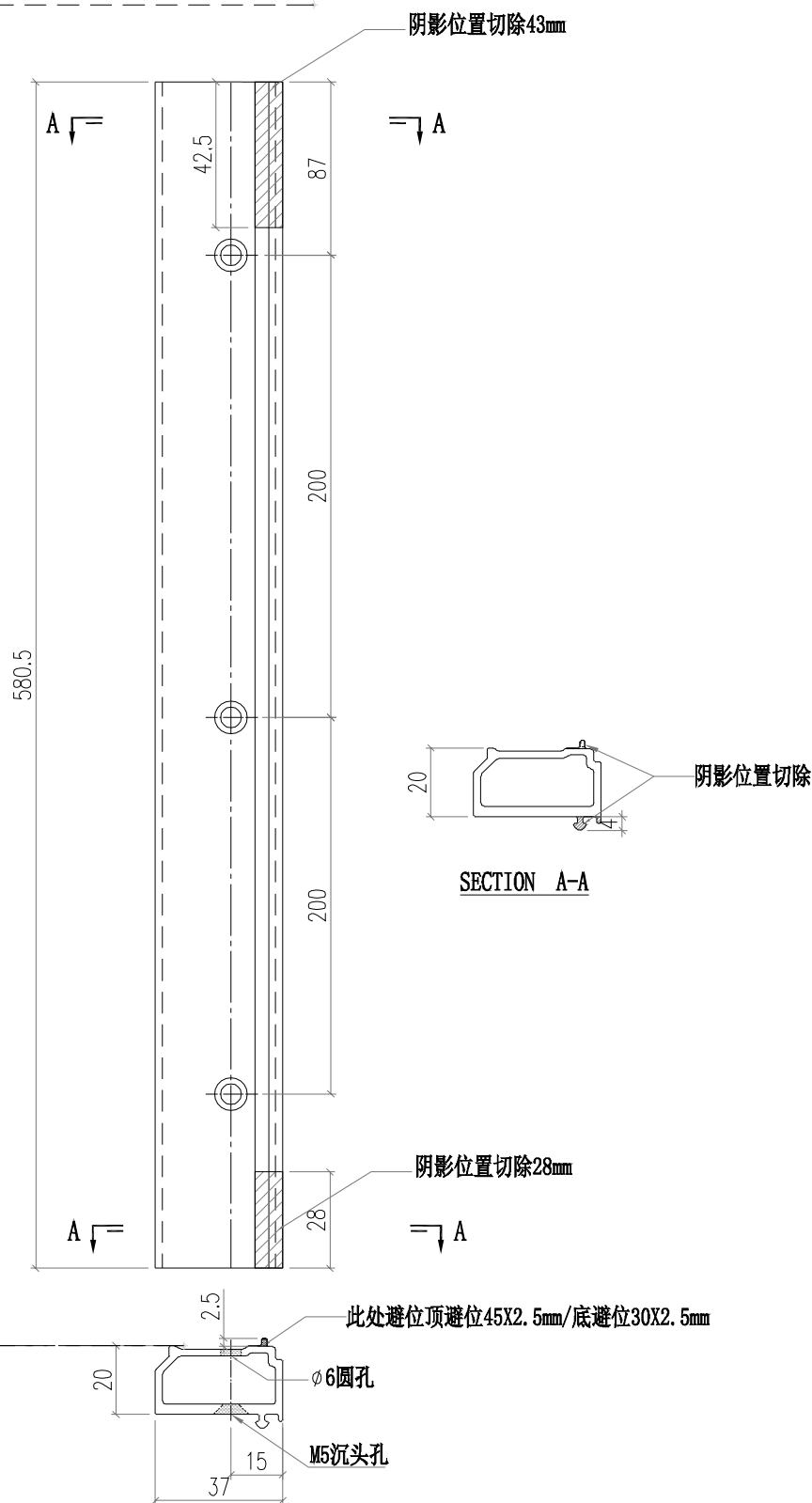

 美特鋁質有限公司 MIDI Aluminium Fabricator Ltd.				工程號 J856	類別	物料號 M1	圖號 X86374-SU01	
地盤 天榮站				制圖 李傳鵬	2022-11-26	數量 -	圖號 X86374-SU01	
修改 日期	採用 工廠	地盤 <input checked="" type="checkbox"/>	圖紙名稱 鋁料加工圖	復核 練松文	2022-11-27	數量 -	單件重量 - (KG)	
材料顏色 - UCT542919XL-3		材料 X86374		批准 林仁安	2022-11-28	單件重量 - (KG)		

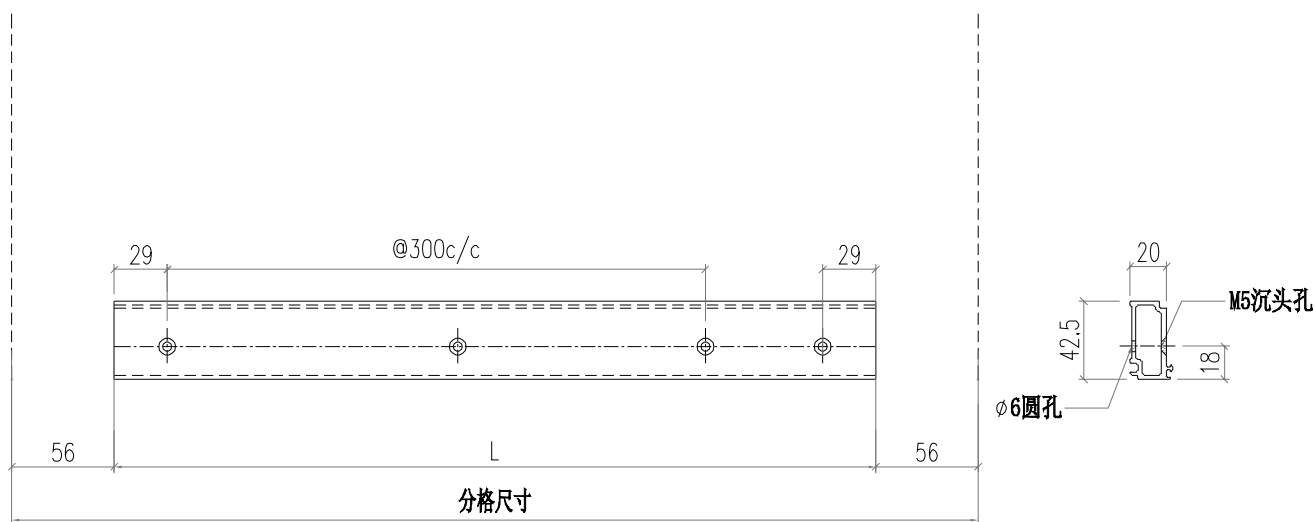

部件编号	L	分格尺寸
X86374-SU01-1	538	650
X86374-SU01-2	1758	1870
X86374-SU01-3	1475.5	1587.5
X86374-SU01-4	773	885
X86374-SU01-5	2088	2200
X86374-SU01-6	1295.5	1407.5
X86374-SU01-7	1858	1970
X86374-SU01-8	808	920
X86374-SU01-9	1208	1320
X86374-SU01-10	788	900
X86374-SU01-11	1095.5	1207.5

 美特鋁質有限公司 MIDI Aluminium Fabricator Ltd.				工程號	J856	類別		物料號	M1		
				地盘	天榮站	制圖	李傳鵬	2022-11-26	圖號	X86375-SU01	
修改		採用工廠	地盘	✓	图纸名称	铝料加工图	復核	練松文	2022-11-27	數量	-
日期		材料颜色	- UCT542919XL-3		材料	X86375	批准	林仁安	2022-11-28	單件重量	- (KG)

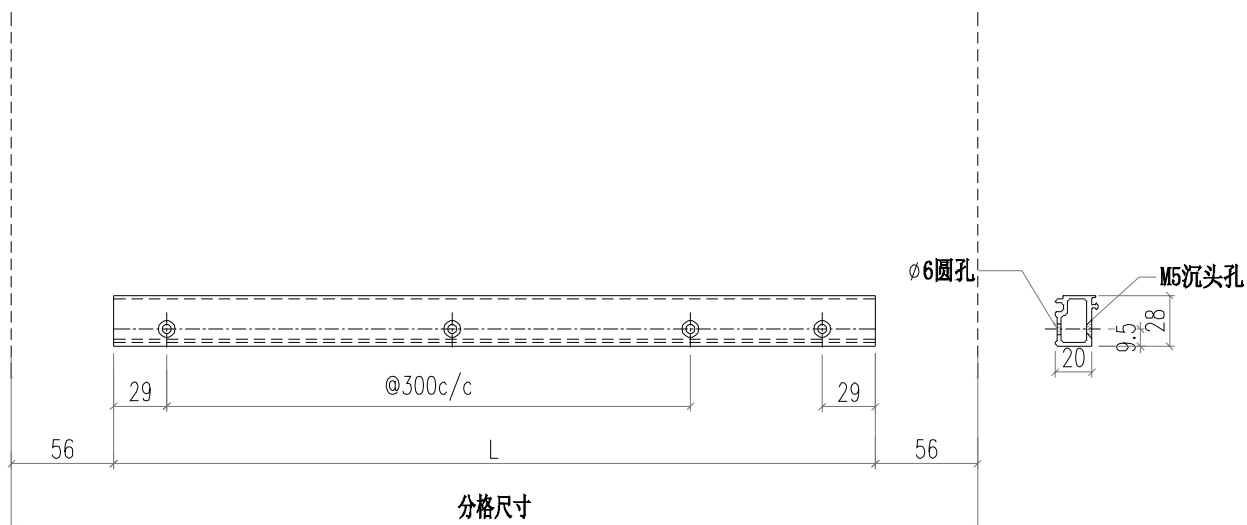

部件编号	L	分格尺寸
X86375-SU01-1	538	650
X86375-SU01-2	1758	1870
X86375-SU01-3	1475.5	1587.5
X86375-SU01-4	773	885
X86375-SU01-5	2088	2200
X86375-SU01-6	1295.5	1407.5
X86375-SU01-7	1858	1970
X86375-SU01-8	808	920
X86375-SU01-9	1208	1320
X86375-SU01-10	788	900
X86375-SU01-11	1095.5	1207.5

 美特鋁質有限公司 MIDI Aluminium Fabricator Ltd.				工程號 J856 地盘 天榮站	類別 制圖 李傳鵬 復核 練松文 批准 林仁安	物料號 M1 2022-11-26 2022-11-27 2022-11-28	圖號 AC01-T01R 數量 - 單件重量 - (KG)
修改 日期	採用工廠 材料颜色 -UCT542919XL-3	地盤 <input checked="" type="checkbox"/>	图纸名称 铝料加工图 材料 AC01				

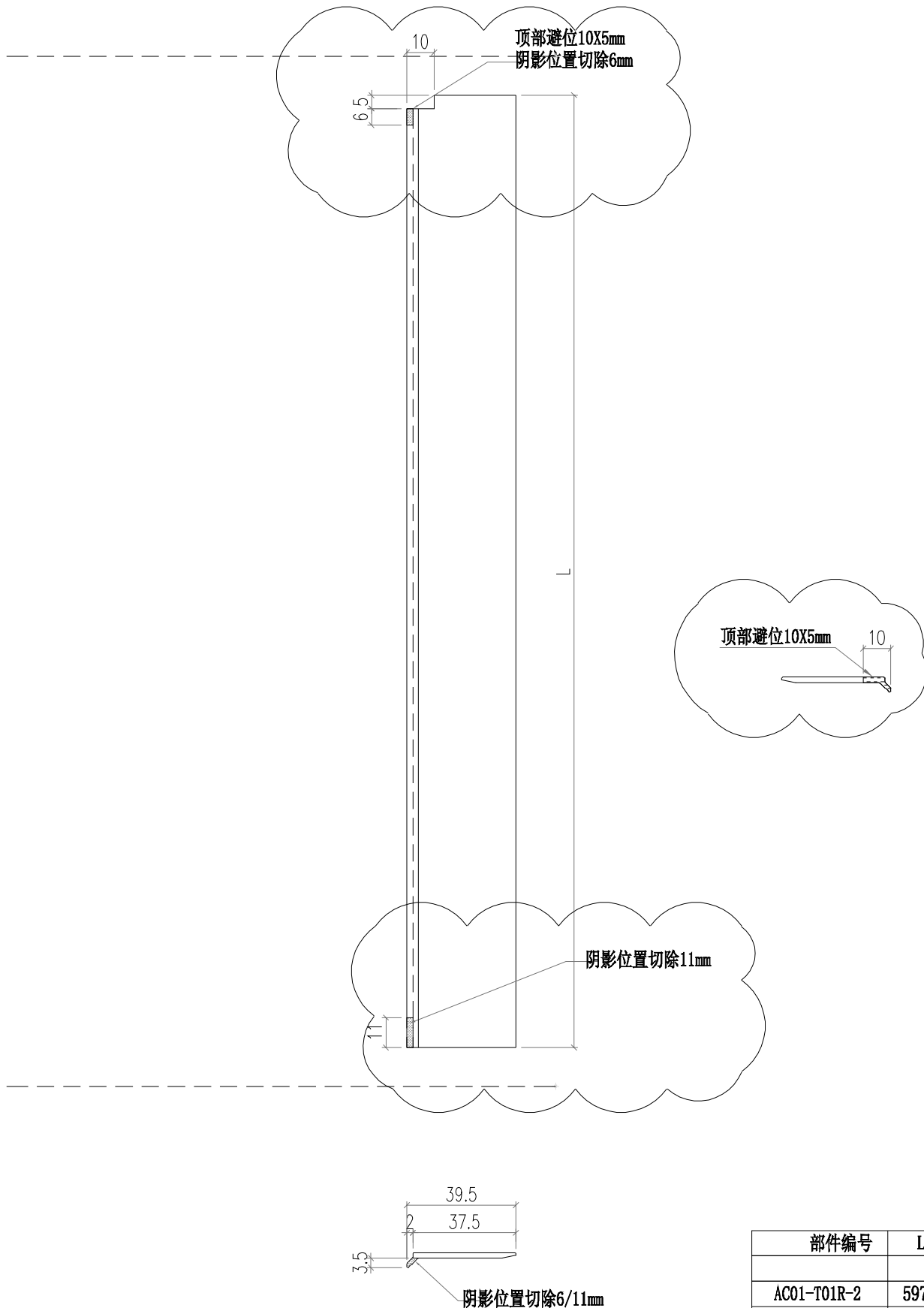

部件编号	L	分格尺寸
AC01-T01R-2	597	625

 美特鋁質有限公司 MIDI Aluminium Fabricator Ltd.			工程號 J856 地盘 天榮站	類別 制圖 李傳鵬 復核 練松文 批准 林仁安	物料號 M1 2022-11-26 2022-11-27 2022-11-28	圖號 AC01-T01 數量 - 單件重量 - (KG)
修改 B 日期 05.18	採用工廠 材料颜色 -UCT542919XL-3	地盤 <input checked="" type="checkbox"/>	图纸名称 铝料加工图 材料 AC01			

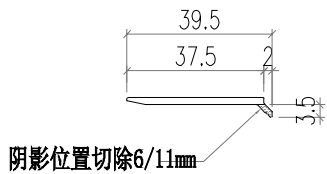
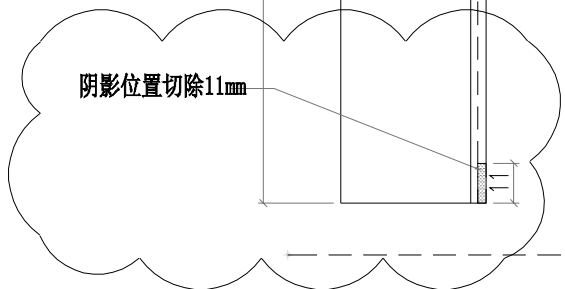
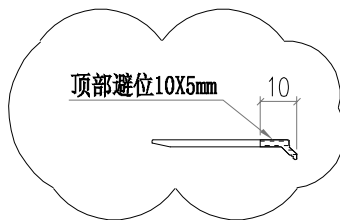
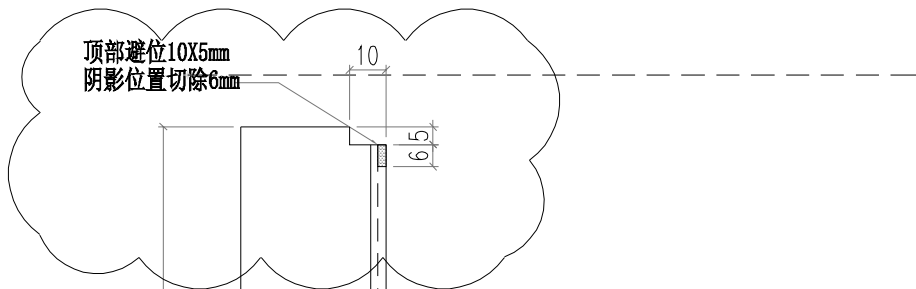

部件编号	L	分格尺寸
AC01-T01-2	597	625

 美特鋁質有限公司 MIDI Aluminium Fabricator Ltd.				工程號 J856 地盘 天榮站	類別 制圖 李傳鵬 復核 練松文 批准 林仁安	物料號 M1 2022-11-26 2022-11-27 2022-11-28	圖號 AC01-T02 數量 - 單件重量 - (KG)
修改 日期	採用工廠 材料顏色	地盘 ✓ -UCT542919XL-3	图纸名称 铝料加工图 材料 AC01				

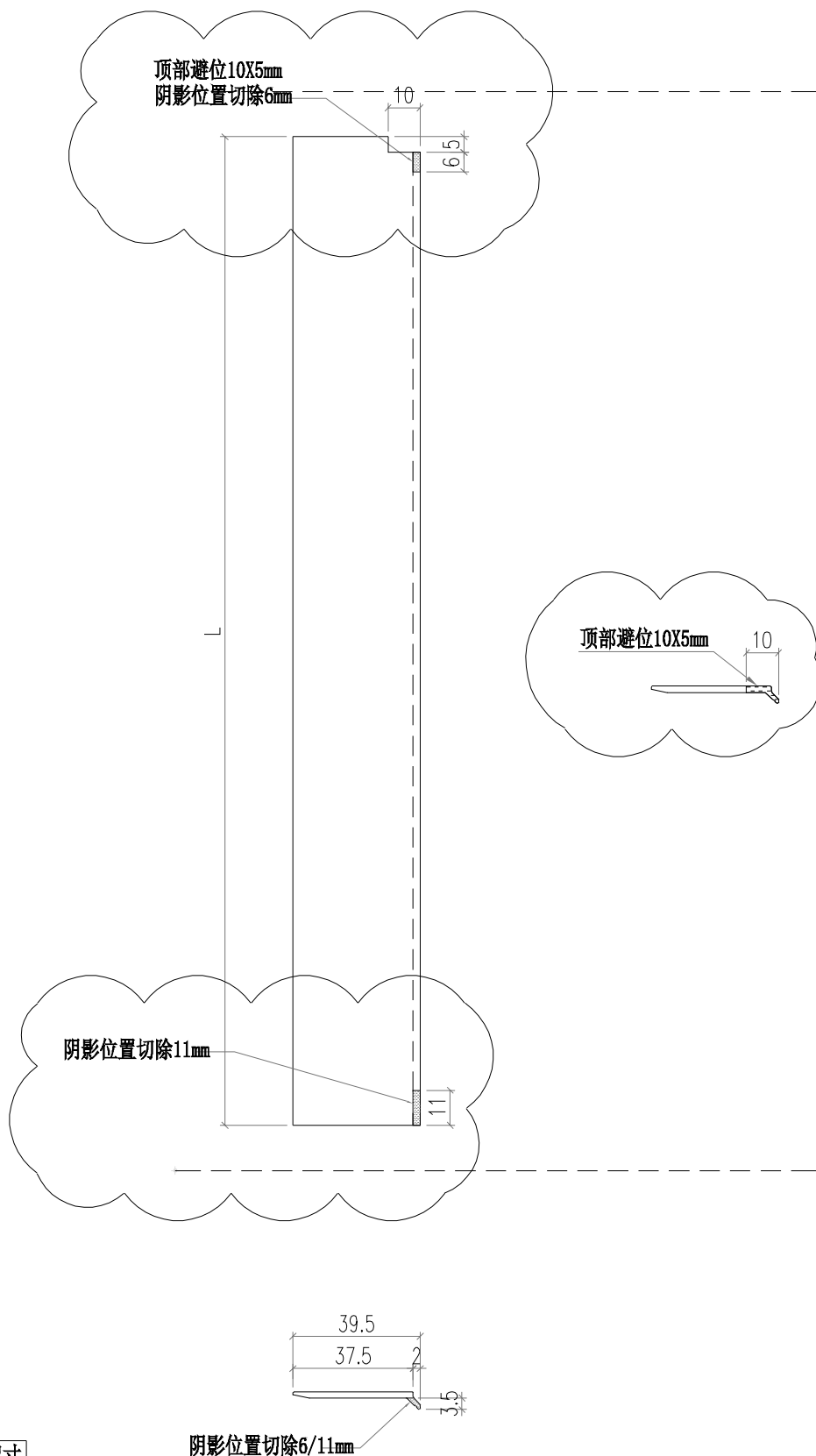

部件编号	L	分格尺寸
AC01-P02-1	872	900
AC01-P02-2	2037	2065

 美特鋁質有限公司 MIDI Aluminium Fabricator Ltd.				工程號 J856 地盘 天榮站	類別 制圖 李傳鵬 復核 練松文 批准 林仁安	物料號 M1 2022-11-26 2022-11-27 2022-11-28	圖號 AC01-T02R 數量 - 單件重量 - (KG)
修改 日期	採用工廠 材料颜色 -UCT542919XL-3	地盤 <input checked="" type="checkbox"/>	图纸名称 铝料加工图 材料 AC01				

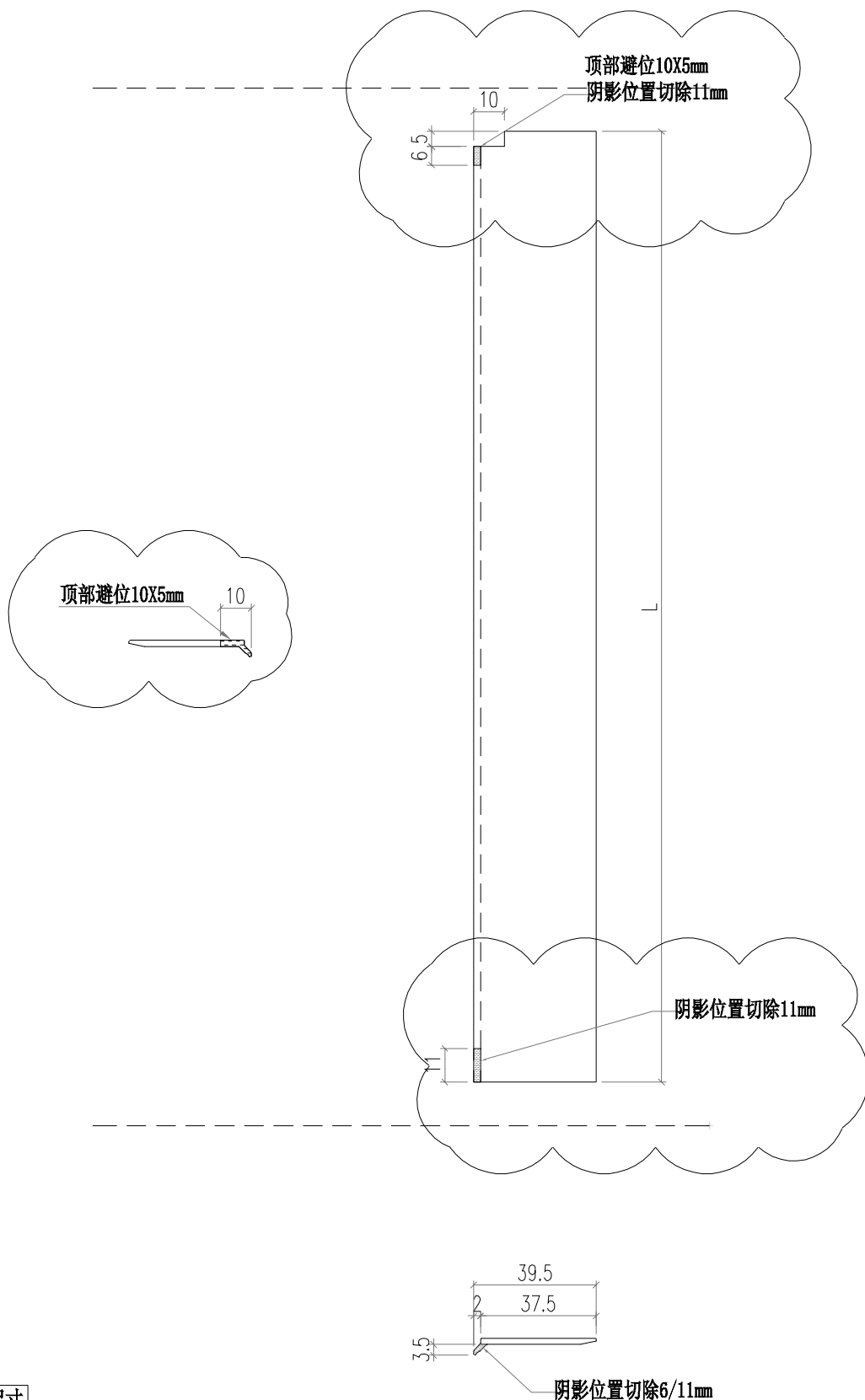

部件编号	L	分格尺寸
AC01-P02R-1	872	900
AC01-P02R-2	2037	2065

 美特鋁質有限公司 MIDI Aluminium Fabricator Ltd.				工程號 J856	類別	物料號 M1		
				地盘 天榮站	制圖 李傳鵬	2022-11-26	圖號 LB-P02	
修改 日期		採用工廠	地盘 <input checked="" type="checkbox"/>	图纸名称 铝料加工图	復核 練松文	2022-11-27	數量 -	
		材料颜色 铬化		材料 3MM铝板	批准 林仁安	2022-11-28	單件重量 -	(KG)

封口片避位修改尺寸

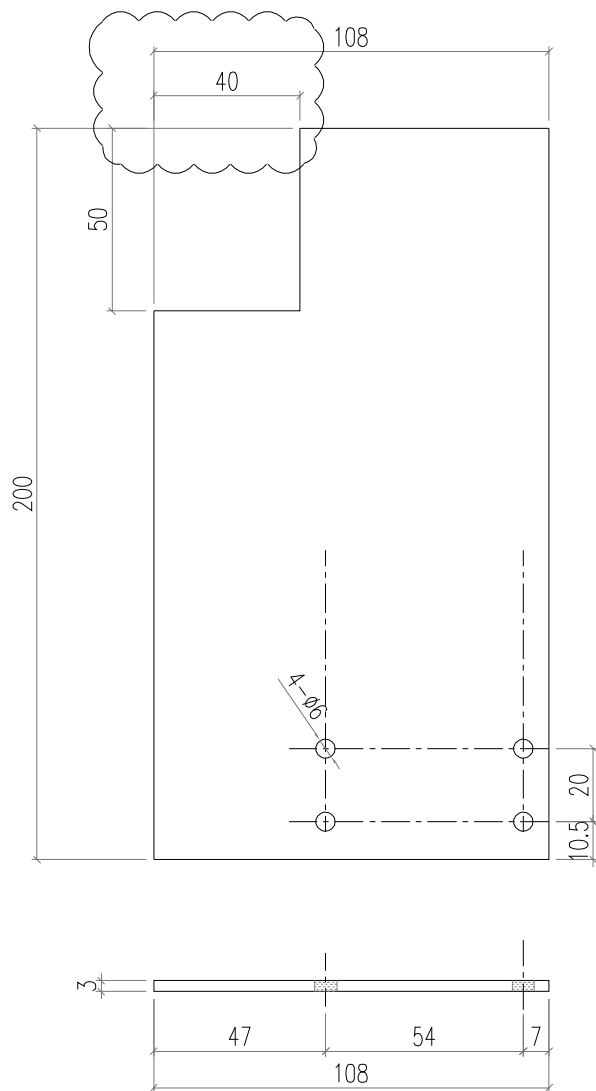

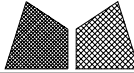
 美特鋁質有限公司 MIDI Aluminium Fabricator Ltd.				工程號 J856	類別 制圖	物料號 M1		
				地盘 天榮站	李傳鵬 2022-11-26	圖號 LB-P01		
修改 日期		採用工廠 地盤 ✓	图纸名称 铝料加工图	復核 練松文 2022-11-27	數量 -			
		材料颜色 鍍化	材料 3MM铝板	批准 林仁安 2022-11-28	單件重量 -	(KG)		

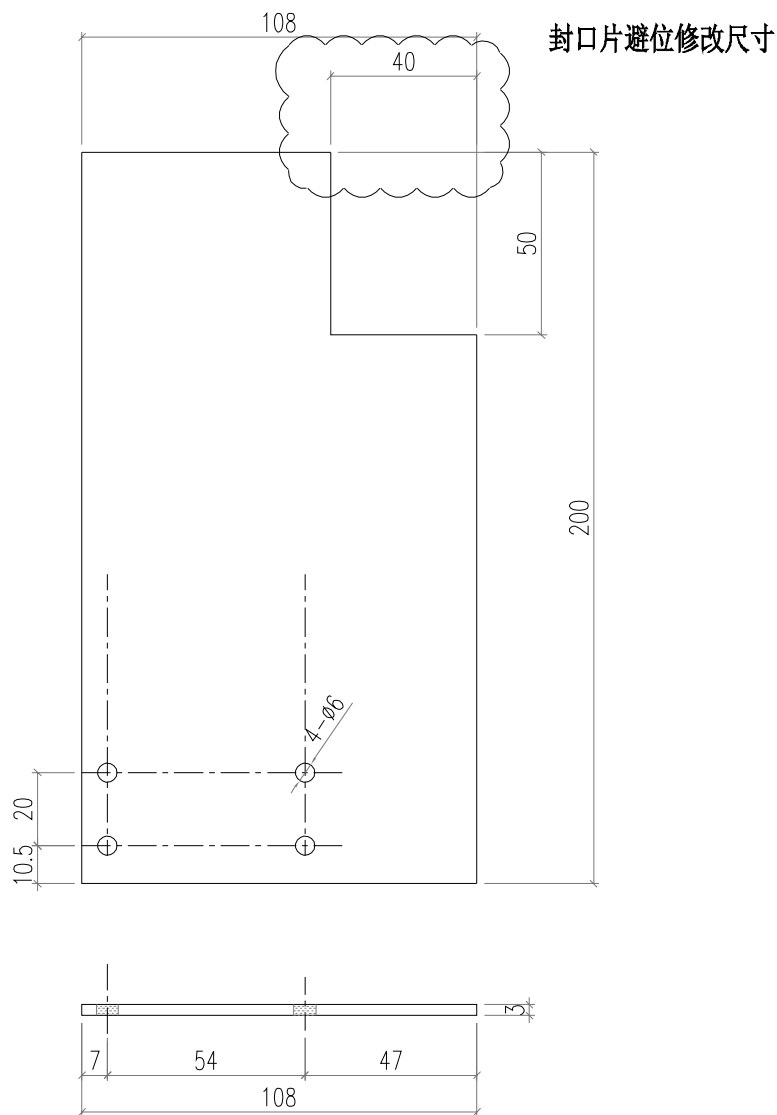

 美特鋁質有限公司 MIDI Aluminium Fabricator Ltd.				工程號	J856	類別		物料號	M1	
				地盘	天榮站	制圖	李傳鵬	2022-11-26	圖號	X86412-P01
修改		採用工廠		地盘	✓	復核	練松文	2022-11-27	數量	-
日期		材料颜色	-UCT542919XL-3	图纸名称	铝料加工图	批准	林仁安	2022-11-28	單件重量	- (KG)

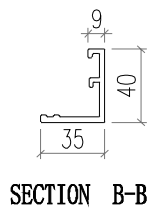
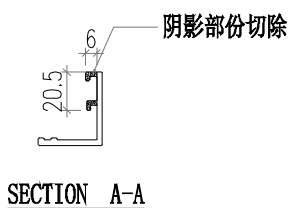
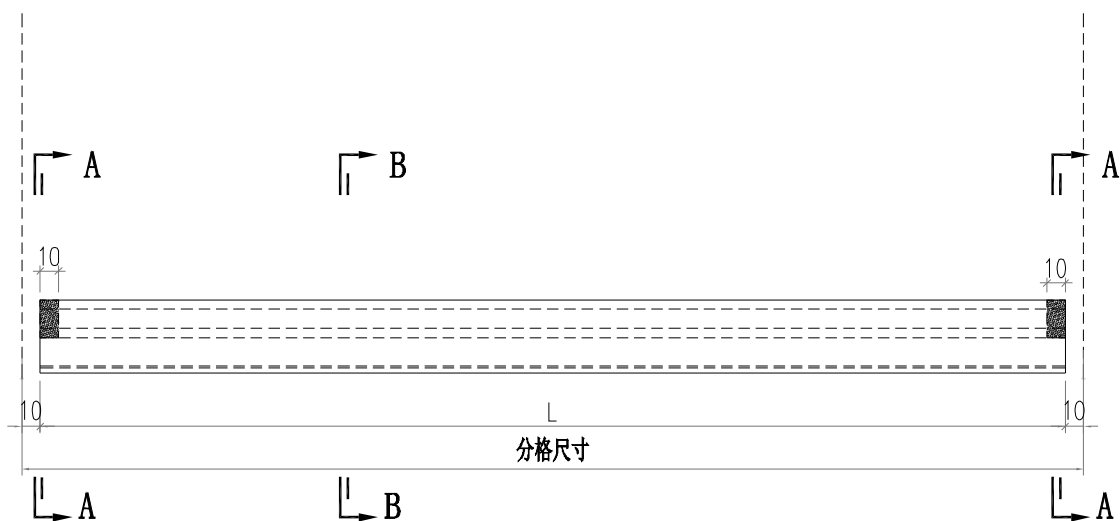

部件编号	L	分格尺寸
X86412-SU01-1	630	650
X86412-SU01-2	1850	1870
X86412-SU01-3	1567.5	1587.5
X86412-SU01-4	865	885
X86412-SU01-5	2180	2200
X86412-SU01-6	1387.5	1407.5
X86412-SU01-7	1950	1970
X86412-SU01-8	900	920
X86412-SU01-9	1300	1320
X86412-SU01-10	880	900
X86412-SU01-11	1187.5	1207.5

 美特鋁質有限公司 MIDI Aluminium Fabricator Ltd.				工程號	J856	類別		物料號	M1		
				地盘	天榮站	制圖	李傳鵬	2022-11-26	圖號	X86412-K01	
修改		採用工廠	地盘	✓	图纸名称	铝料加工图	復核	練松文	2022-11-27	數量	-
日期		材料颜色	-UCT542919XL-3		材料	X86412	批准	林仁安	2022-11-28	單件重量	- (KG)

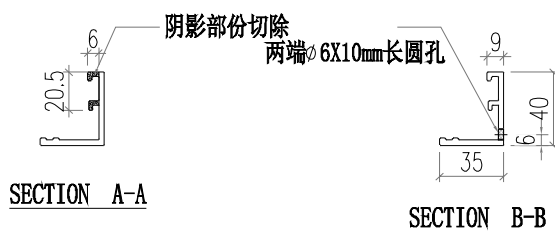
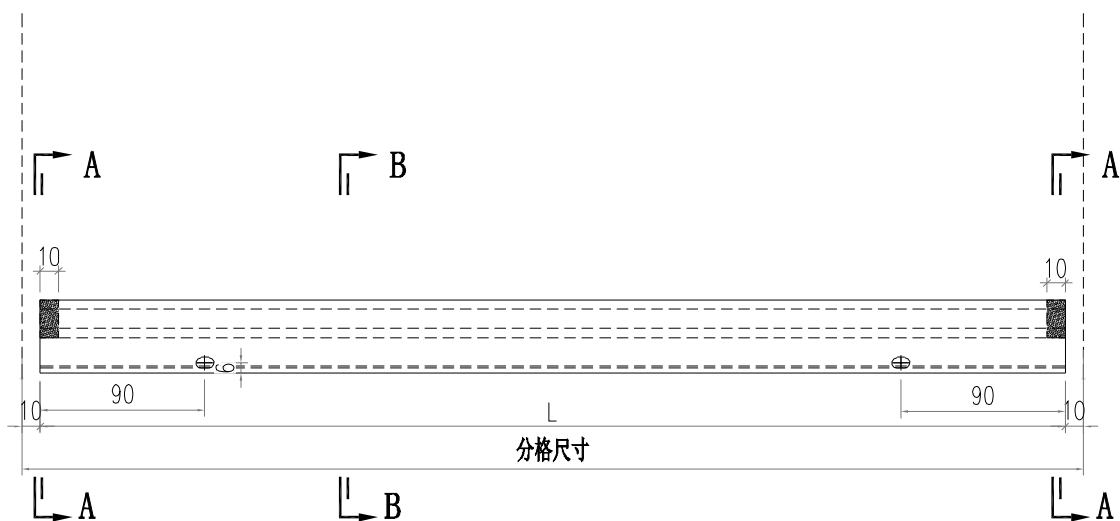

部件编号	L	分格尺寸
X86412-SK01-1	630	650
X86412-SK01-2	1850	1870
X86412-SK01-3	1567.5	1587.5
X86412-SK01-4	865	885
X86412-SK01-5	2180	2200
X86412-SK01-6	1387.5	1407.5
X86412-SK01-7	1950	1970
X86412-SK01-8	900	920
X86412-SK01-9	1300	1320
X86412-SK01-10	880	900
X86412-SK01-11	1187.5	1207.5

 美特鋁質有限公司 MIDI Aluminium Fabricator Ltd.				工程號 J856	類別 天榮站	物料號 M1	圖號 X86372-P01
修改 日期	- -	採用工廠 地盤	<input checked="" type="checkbox"/>	图纸名称 铝料加工图	制圖 李傳鵬	2022-11-26	數量 -
		材料颜色 -		材料 X86372	復核 練松文	2022-11-27	單件重量 - (KG)
					批准 林仁安	2022-11-28	

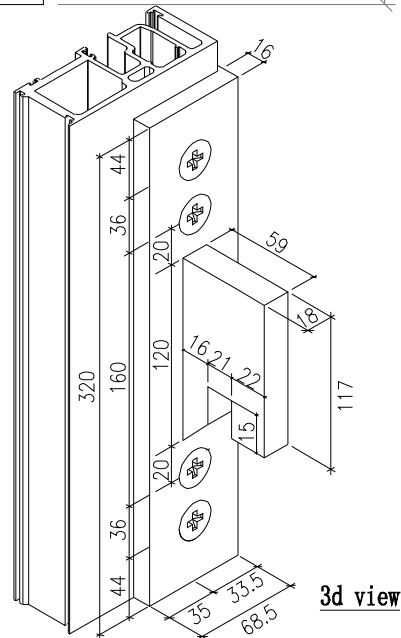
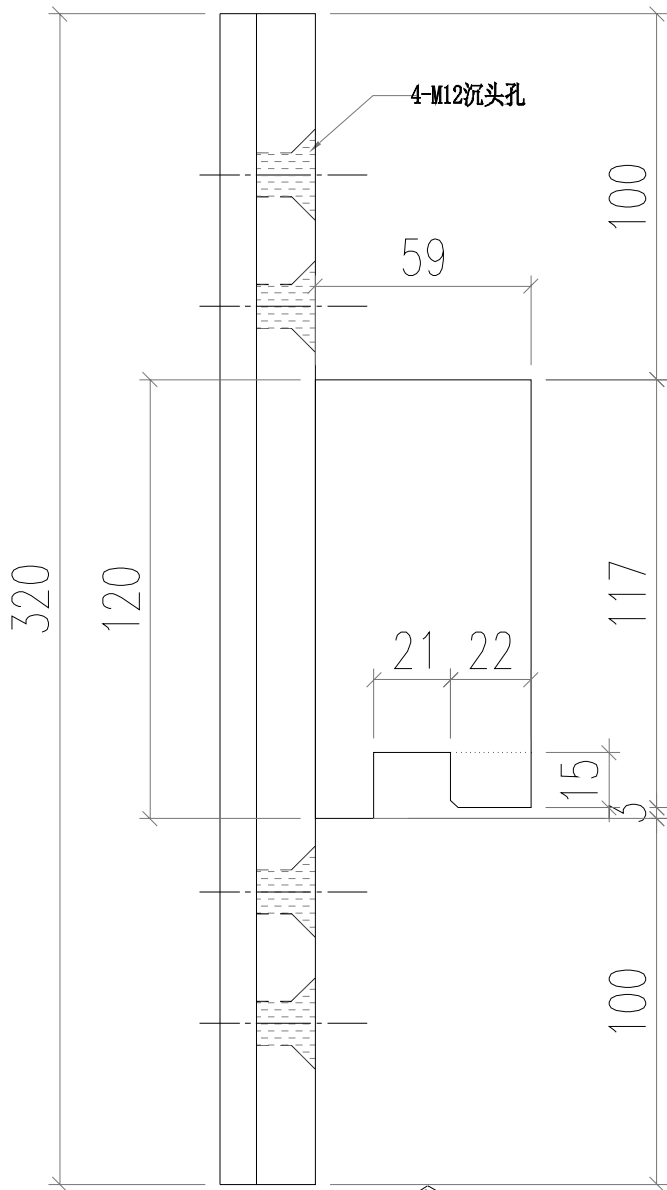
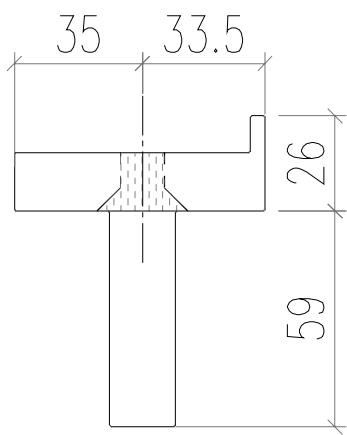
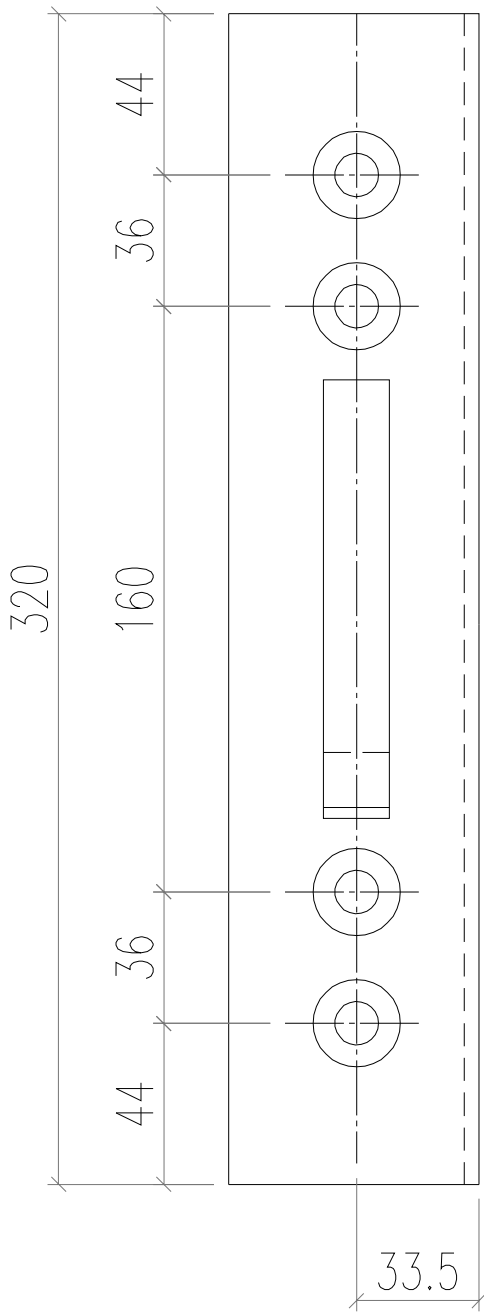

 美特鋁質有限公司 MIDI Aluminium Fabricator Ltd.				工程號 J856	類別 天榮站	物料號 M1	圖號 X86372-P02
修改 日期	採用 工廠	地盤 <input checked="" type="checkbox"/>	圖紙名稱 鋁料加工圖	制圖 李傳鵬	2022-11-26	數量 -	單件重量 - (KG)
	材料顏色 -		材料 AB03	復核 練松文	2022-11-27		
				批准 林仁安	2022-11-28		

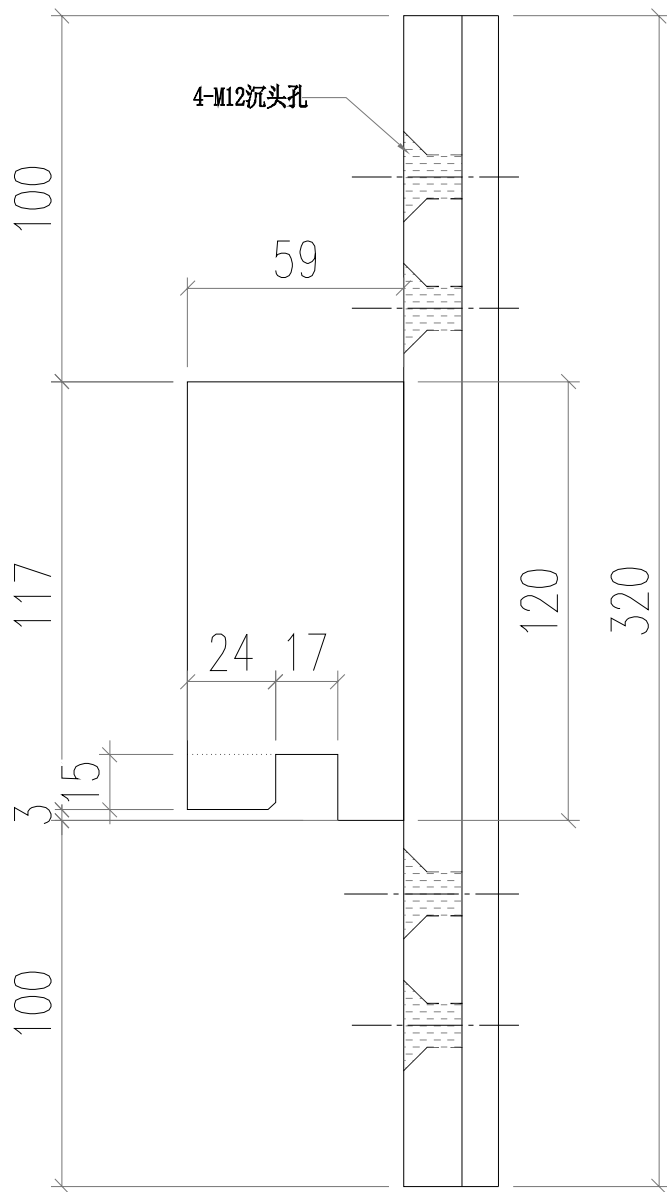
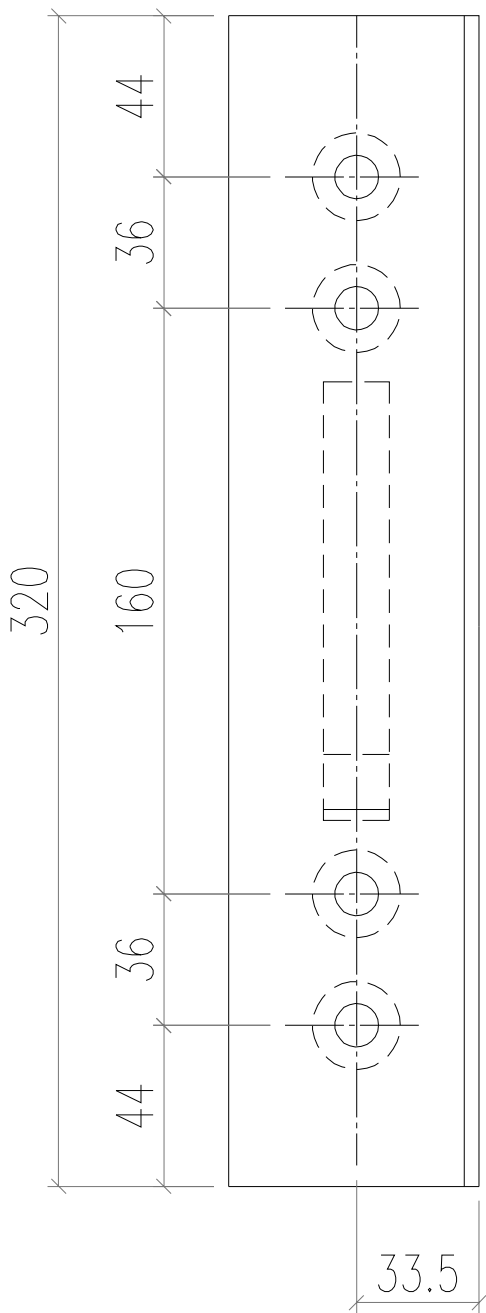

4-M12沉头孔

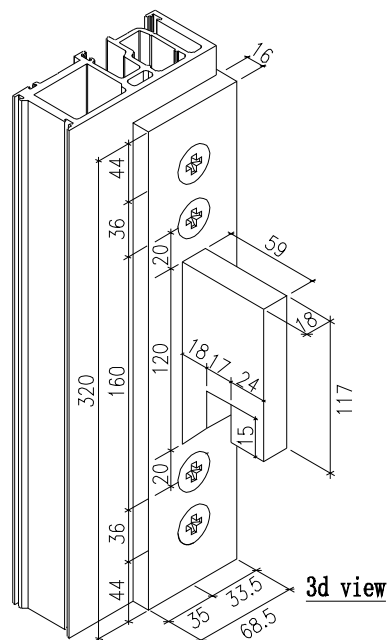
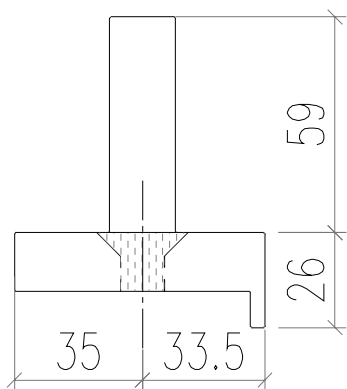

3d view

 美特鋁質有限公司 MIDI Aluminium Fabricator Ltd.				工程號 J856	類別	物料號 M1		
				地盘 天榮站	制圖 李傳鵬	2022-11-25	圖號 GS01-K02	
修改 日期		採用工廠	地盘 <input checked="" type="checkbox"/>	图纸名称 铝料加工图	復核 練松文	2022-11-27	數量 -	
		材料颜色 -		材料 GS01	批准 林仁安	2022-11-28	單件重量 -	(KG)

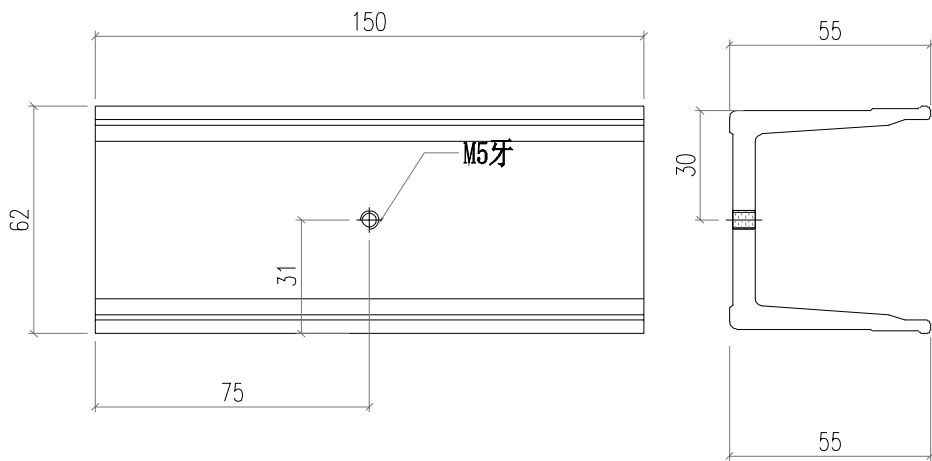

 美特鋁質有限公司 MIDI Aluminium Fabricator Ltd.				工程號 J856	類別 制圖	物料號 M1	圖號 GS01-K01	
地盤 天榮站				制圖 李傳鵬	日期 2022-11-25	圖號 GS01-K01	數量 -	
修改 日期	採用 工廠	地盤 <input checked="" type="checkbox"/>	圖紙名稱 鋁料加工圖	復核 練松文	日期 2022-11-27	數量 -	單件重量 - (KG)	
材料顏色 -				材料 GS01	批准 林仁安	日期 2022-11-28	單件重量 - (KG)	

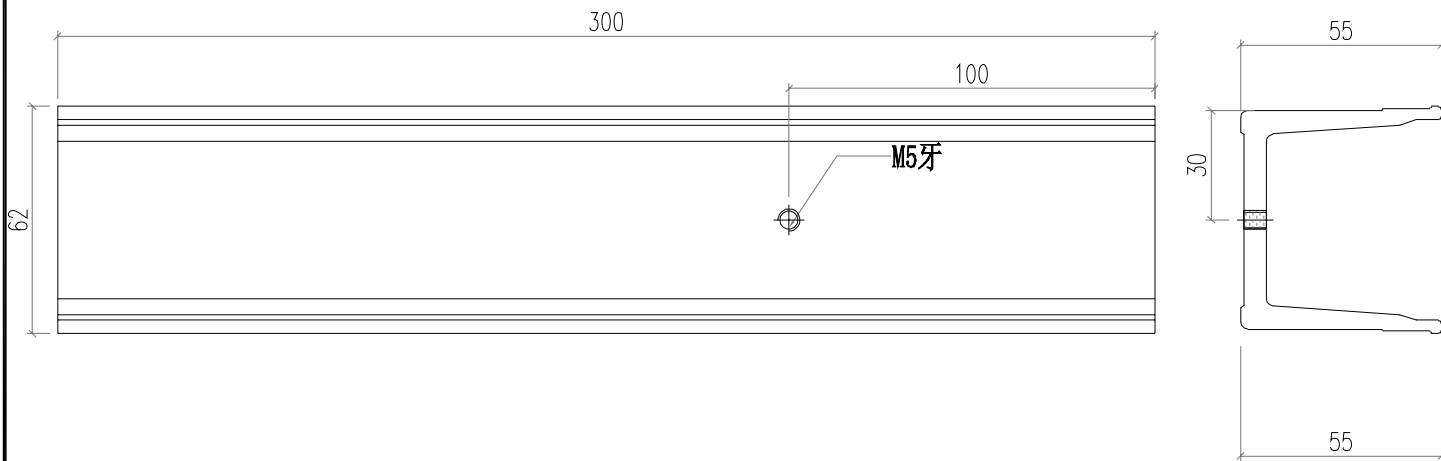

 美特鋁質有限公司 MIDI Aluminium Fabricator Ltd.				工程號 J856	類別 制圖	物料號 M1	圖號 AS01-001	
地盤 天榮站				制圖 李傳鵬	2022-11-25	圖號 數量	-	
修改 日期	採用 工廠	地盤 <input checked="" type="checkbox"/>	圖紙名稱 鋁料加工圖	復核 練松文	2022-11-27	數量 單件重量	- (KG)	
材料顏色 -				材料 AS01	批准 林仁安	2022-11-28	- (KG)	

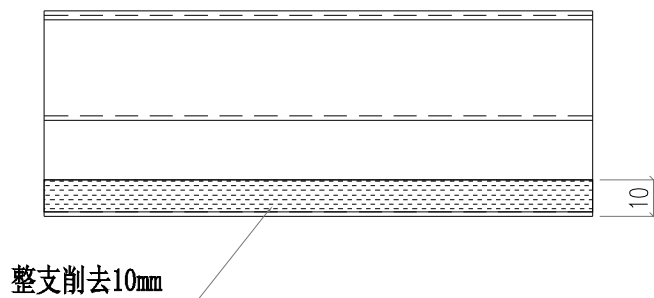
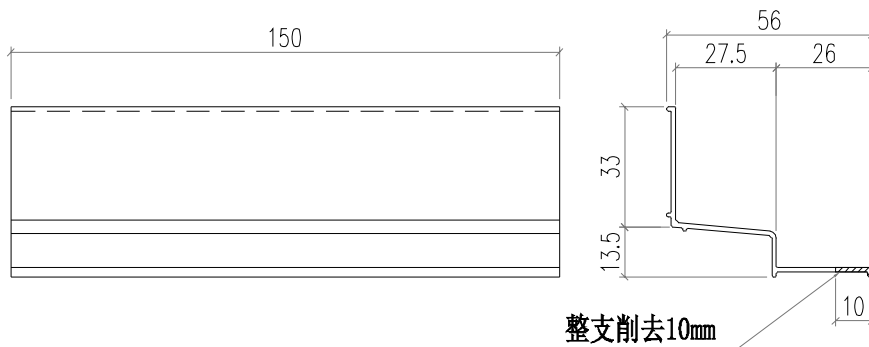

 美特鋁質有限公司 MIDI Aluminium Fabricator Ltd.				工程號 J856	類別 天榮站	物料號 M1	圖號 J60x38-001
修改 日期	採用 工廠	地盤 <input checked="" type="checkbox"/>	圖紙名稱 鋁料加工圖	制圖 李傳鵬	2022-11-26	數量 -	單件重量 - (KG)
	材料顏色 -		材料 76.2x50.8x3.18鋁	復核 練松文	2022-11-27		
				批准 林仁安	2022-11-28		

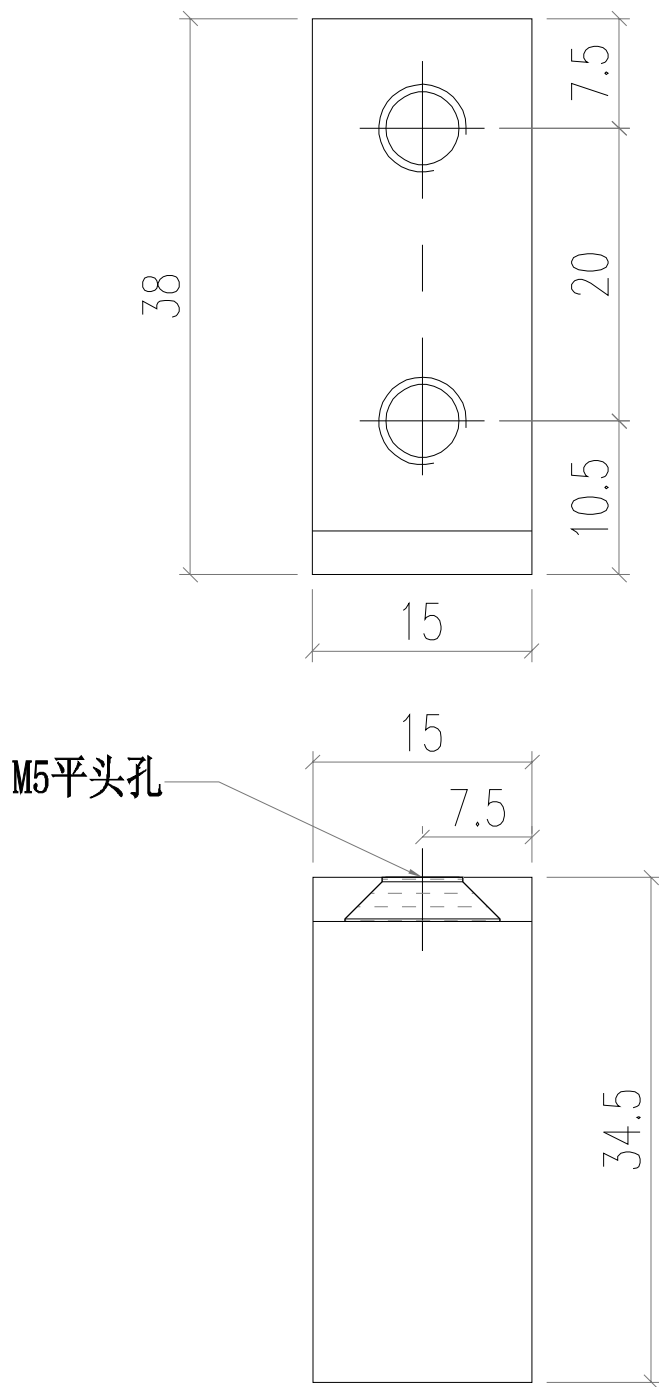

用鋁角76.2X50.8X3.18切成

 美特鋁質有限公司 MIDI Aluminium Fabricator Ltd.				工程號 J856	類別 天榮站	物料號 M1	圖號 J60x38-003
修改 日期	採用 工廠	地盤 <input checked="" type="checkbox"/>	圖紙名稱 鋁料加工圖	制圖 李傳鵬	2022-11-26	數量 -	單件重量 - (KG)
	材料顏色 -		材料 76.2x50.8x3.18鋁	復核 練松文	2022-11-27		
				批准 林仁安	2022-11-28		

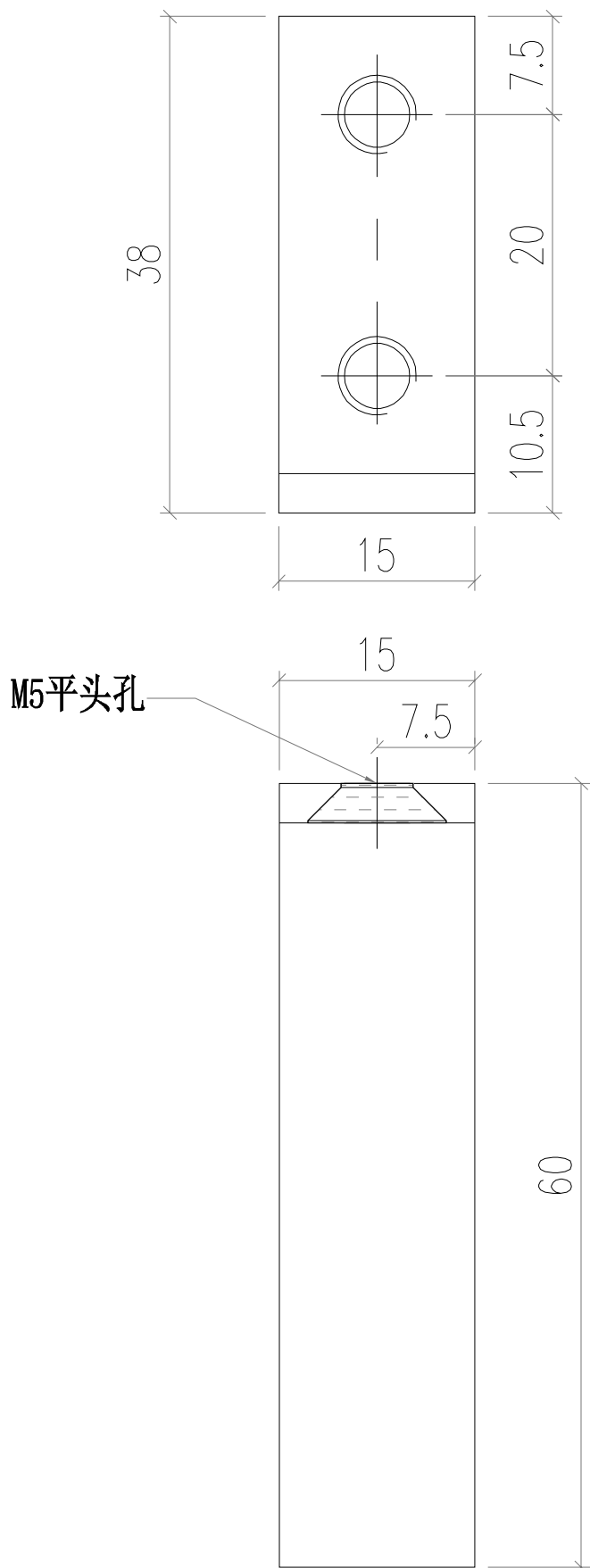

用鋁角76.2X50.8X3.18切成

 美特鋁質有限公司 MIDI Aluminium Fabricator Ltd.				工程號 J856	類別 天榮站	物料號 M1	圖號 J60x38-002
修改 -	採用 <input type="checkbox"/>	工廠 <input type="checkbox"/>	地盤 <input checked="" type="checkbox"/>	圖紙名稱 鋁料加工圖	制圖 李傳鵬	2022-11-26	數量 -
日期 -	材料 76.2x50.8x3.18鋁	顏色 -	圖紙 <input type="checkbox"/>	復核 練松文	2022-11-27	2022-11-27	單件重量 - (KG)

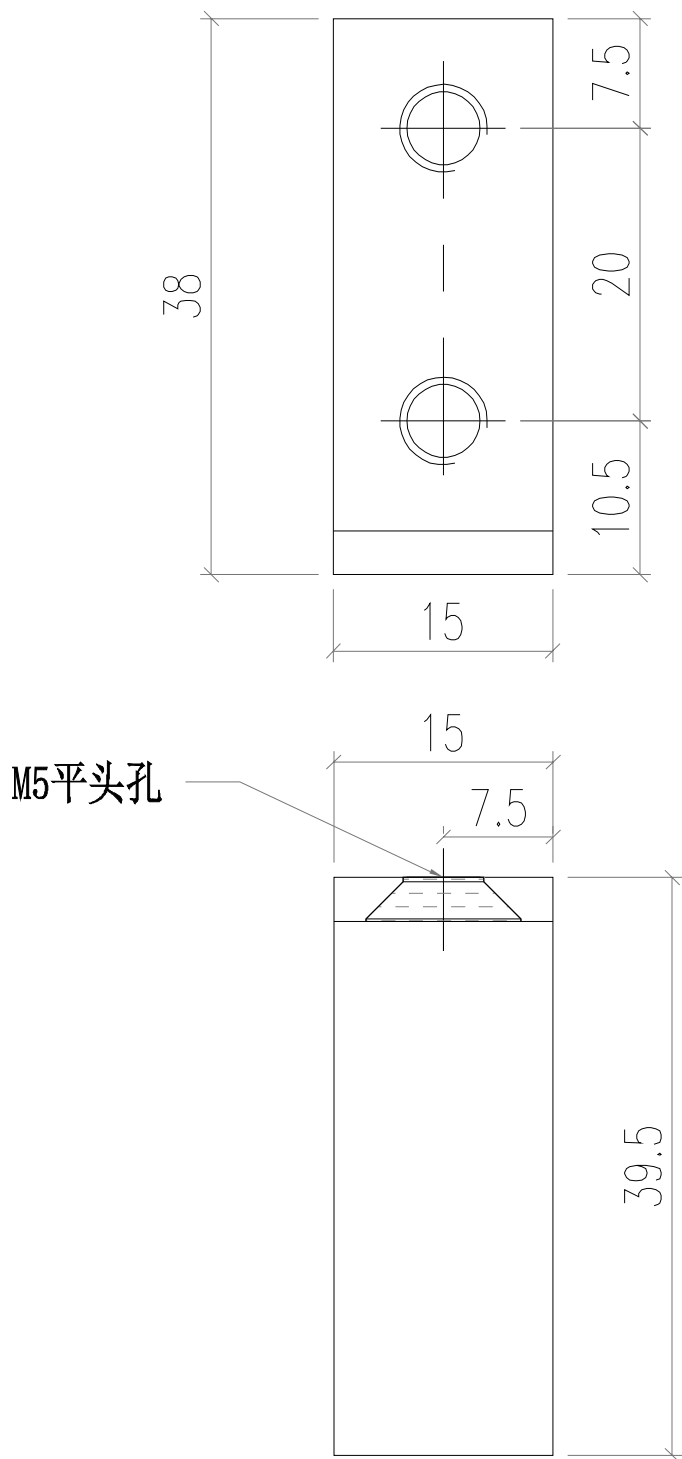

用鋁角76.2X50.8X3.18切成

 美特鋁質有限公司 MIDI Aluminium Fabricator Ltd.				工程號 J856	類別 天榮站	物料號 M1	圖號 MS01-001	
修改 日期	採用 工廠	地盤 <input checked="" type="checkbox"/>	圖紙名稱 铝料加工圖	制圖 李傳鵬	2022-11-26	圖號 數量	-	
日期	材料顏色 -		材料 MS01	復核 練松文	2022-11-27	數量 單件重量	- (KG)	
				批准 林仁安	2022-11-28			

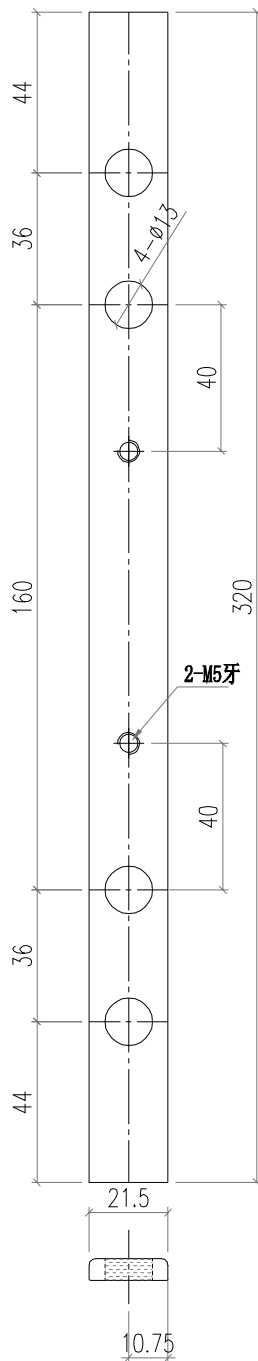

 美特鋁質有限公司 MIDI Aluminium Fabricator Ltd.				工程號 J856	類別	物料號 M1		
				地盘 天榮站	制圖 李傳鵬	2022-11-26	圖號 AJ03-SU02	
修改 日期		採用工廠 <input type="checkbox"/>	地盘 <input checked="" type="checkbox"/>	图纸名称 铝料加工图	復核 練松文	2022-11-27	數量 -	
				材料 AJ03	批准 林仁安	2022-11-28	單件重量 -	(KG)

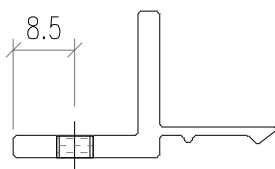
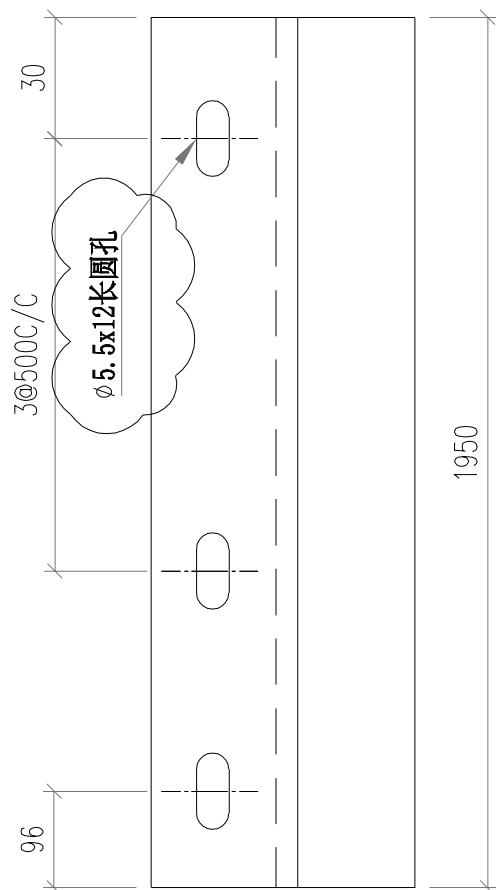

 美特鋁質有限公司 MIDI Aluminium Fabricator Ltd.				工程號 J856	類別	物料號 M1		
				地盘 天榮站	制圖 李傳鵬	2022-11-26	圖號 AJ03-SU01	
修改 日期		採用工廠 <input type="checkbox"/>	地盘 <input checked="" type="checkbox"/>	图纸名称 铝料加工图	復核 練松文	2022-11-27	數量 -	
				材料 AJ03	批准 林仁安	2022-11-28	單件重量 -	(KG)

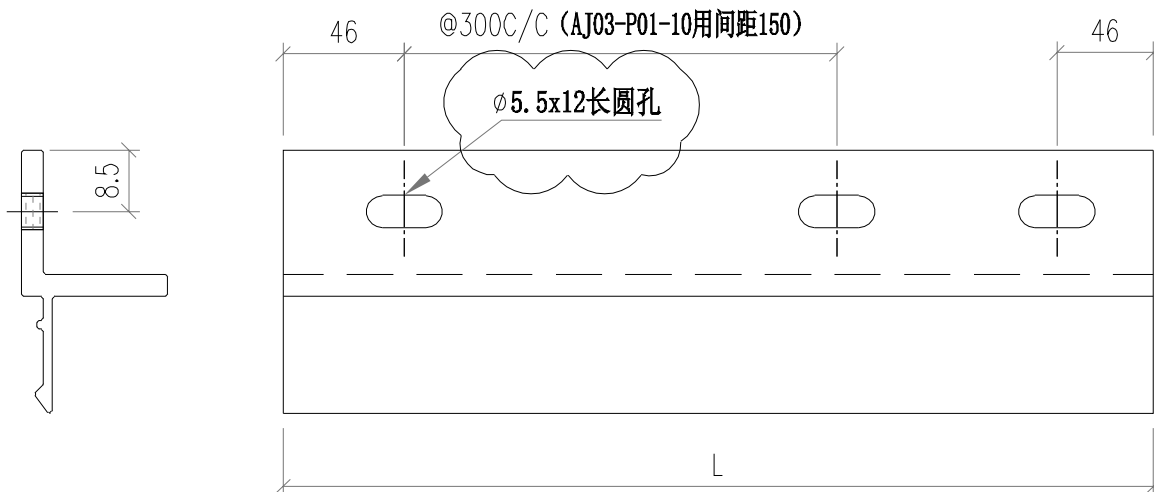

部件编号	L	分格尺寸
AJ03-SU01-1	530	650
AJ03-SU01-2	1750	1870
AJ03-SU01-3	1467.5	1587.5
AJ03-SU01-4	765	885
AJ03-SU01-5	2080	2200
AJ03-SU01-6	1287.5	1407.5
AJ03-SU01-7	1850	1970
AJ03-SU01-8	800	920
AJ03-SU01-9	1200	1320
AJ03-SU01-10	780	900
AJ03-SU01-11	1087.5	1207.5

 美特鋁質有限公司 MIDI Aluminium Fabricator Ltd.				工程號 J856	類別	物料號 M1		
				地盘 天榮站	制圖 李傳鵬	2022-11-26	圖號 AJ03-SU03	
修改 日期		採用工廠	地盘 <input checked="" type="checkbox"/>	图纸名称 铝料加工图	復核 練松文	2022-11-27	數量 -	
				材料 AJ03	批准 林仁安	2022-11-28	單件重量 -	(KG)

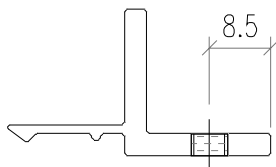
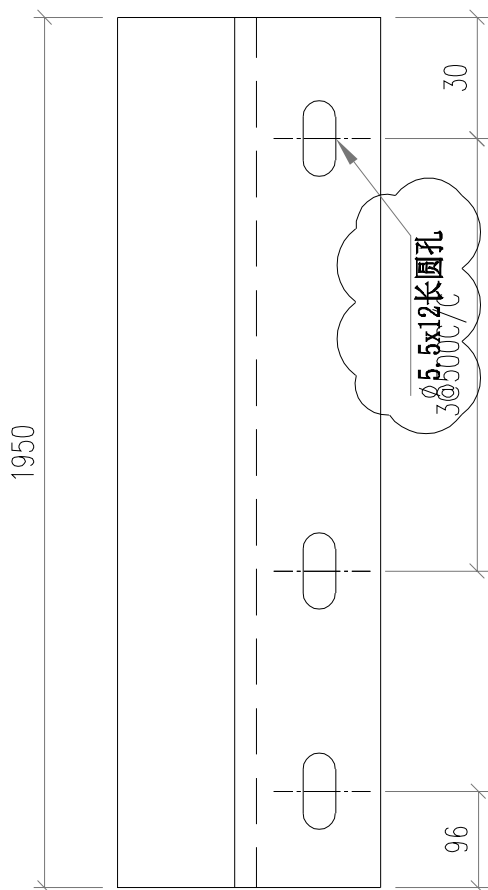

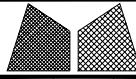
 美特鋁質有限公司 MIDI Aluminium Fabricator Ltd.				工程號 J856	類別 制圖	物料號 M1	圖號 AX04-P02
地盤 天榮站				制圖 李傳鵬	日期 2022-11-26	圖號 數量	AX04-P02 -
修改 日期	採用 工廠	地盤 ✓	圖紙名稱 鋁料加工圖	復核 練松文	日期 2022-11-27	數量 單件重量	- - (KG)
材料顏色 鉻化				材料 3MM鋁板	批准 林仁安	日期 2022-11-28	單件重量 - (KG)

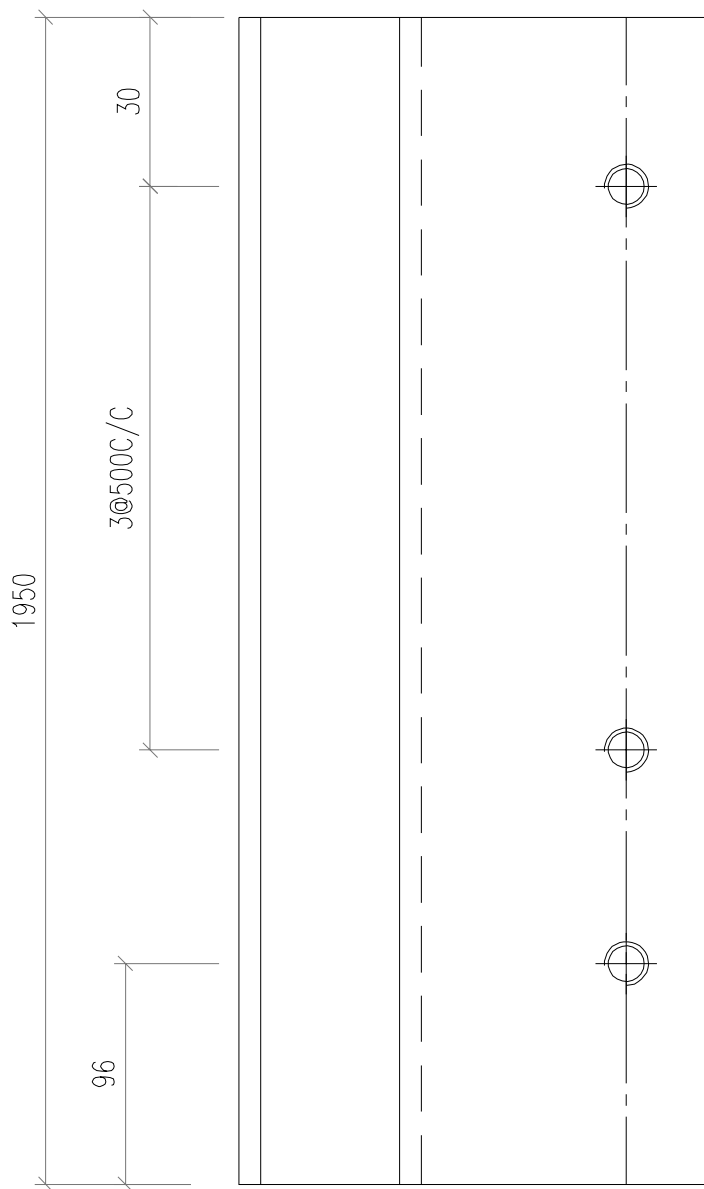

用鋁板折

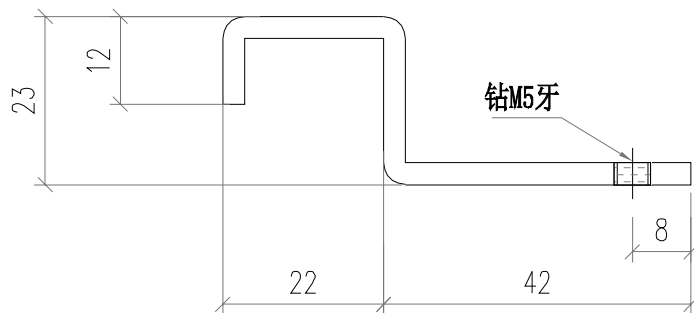

 美特鋁質有限公司 MIDI Aluminium Fabricator Ltd.				工程號 J856 地盘 天榮站	類別 制圖 李傳鵬 復核 練松文 批准 林仁安	物料號 M1 2022-11-26 2022-11-27 2022-11-28	圖號 AX04-P01 數量 - 單件重量 - (KG)
修改 日期	採用工廠 材料颜色 铬化	地盤 <input checked="" type="checkbox"/>	图纸名称 铝料加工图 材料 3MM铝板				

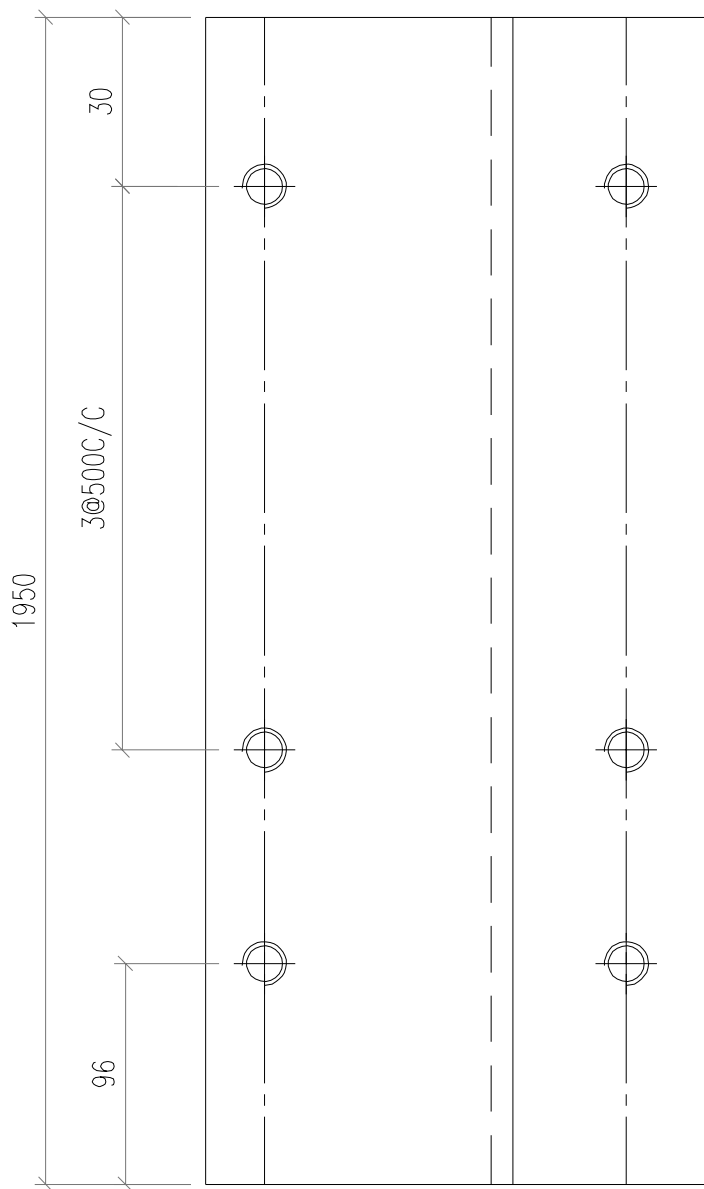

用铝板折

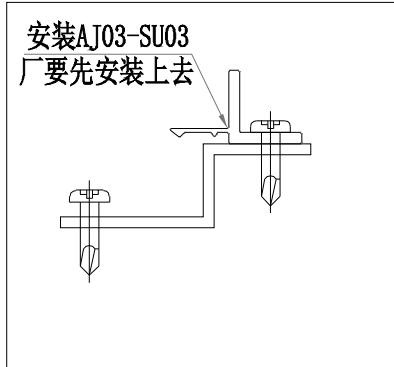
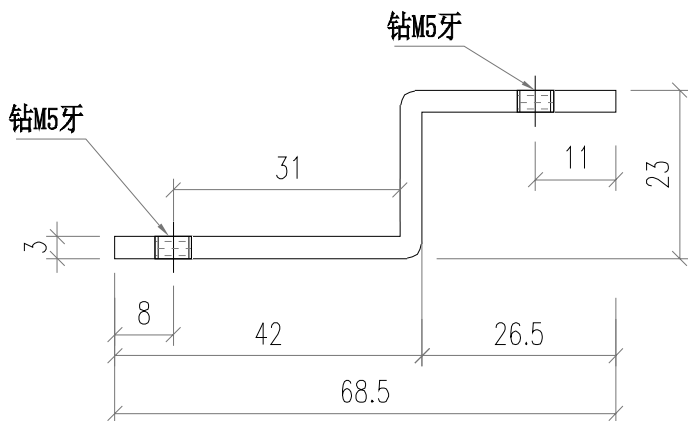

 美特鋁質有限公司 MIDI Aluminium Fabricator Ltd.				工程號 J856	類別 天榮站	物料號 M1	圖號 AJ04-P02
修改 日期	採用 工廠	地盤 <input checked="" type="checkbox"/>	圖紙名稱 鋁料加工圖	制圖 李傳鵬	2022-11-26	數量 -	單件重量 - (KG)
	材料顏色 -		材料 AJ04	復核 練松文	2022-11-27		
				批准 林仁安	2022-11-28		

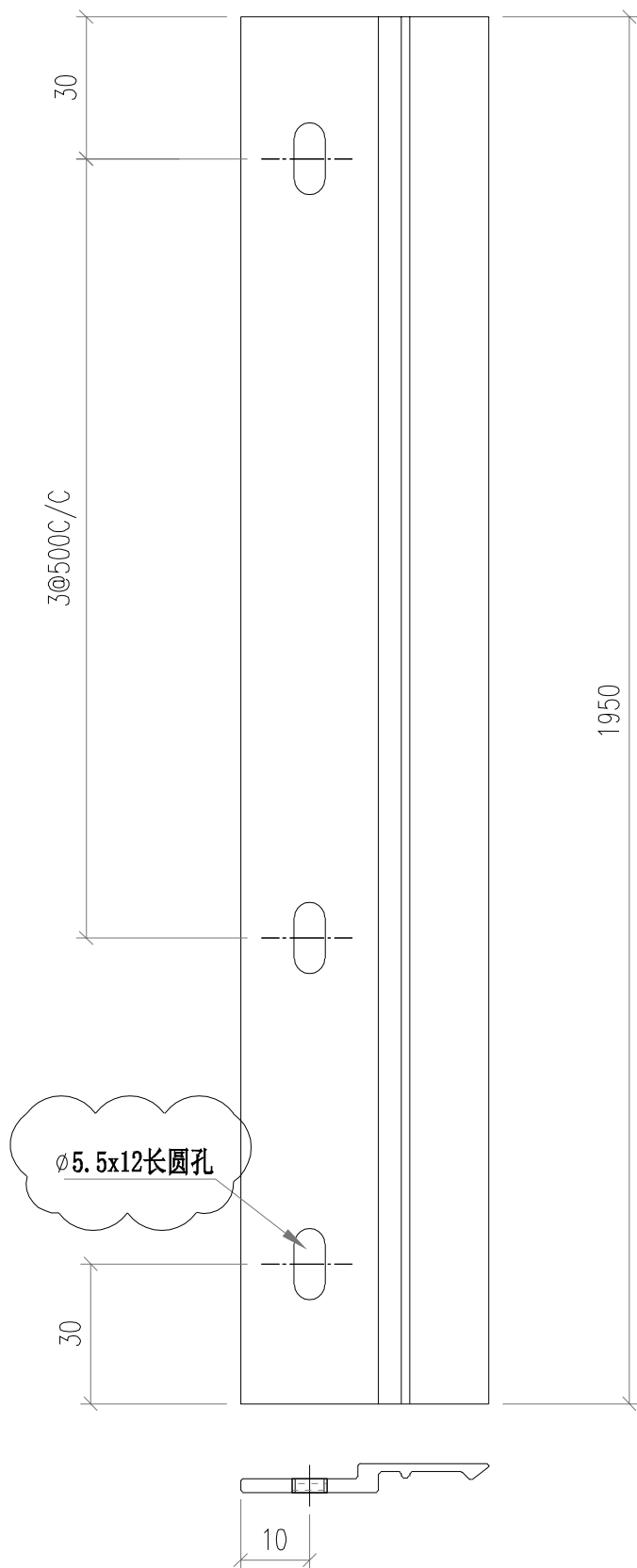

 美特鋁質有限公司 MIDI Aluminium Fabricator Ltd.				工程號 J856	類別 天榮站	物料號 M1	圖號 AJ04-P01
修改 日期	採用 工廠	地盤 <input checked="" type="checkbox"/>	图纸名称 铝料加工图	制圖 李傳鵬	2022-11-26	數量 -	單件重量 - (KG)
	材料颜色 -		材料 AJ04	復核 練松文	2022-11-27		
				批准 林仁安	2022-11-28		

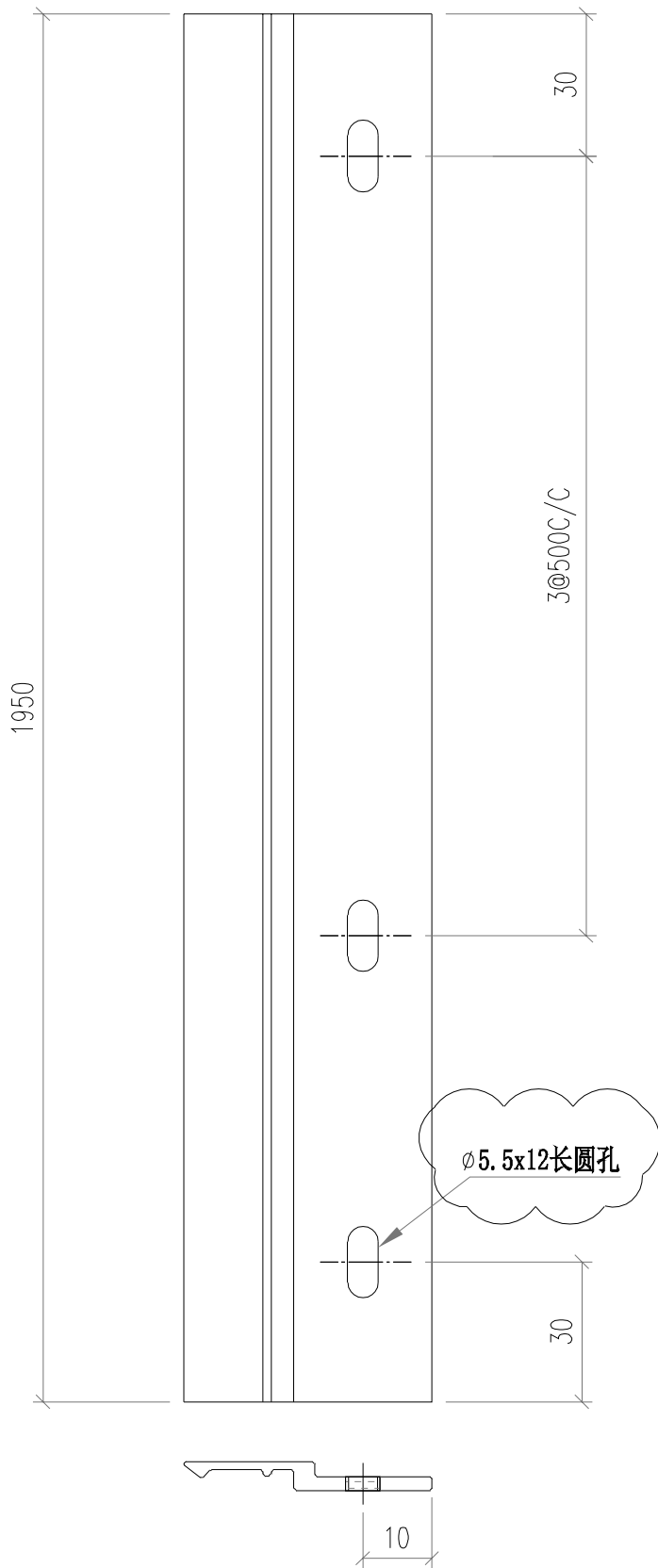

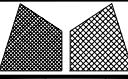
 美特鋁質有限公司 MIDI Aluminium Fabricator Ltd.				工程號 J856	類別 制圖	物料號 M1	圖號 AX04-P04	
地盤 天榮站				復核 李傳鵬	2022-11-26	數量 -	單件重量 - (KG)	
修改 日期	採用 工廠	地盤 ✓	圖紙名稱 鋁料加工圖	復核 練松文	2022-11-27	數量 -	單件重量 - (KG)	
材料顏色 鉻化				材料 3MM鋁板	批准 林仁安	2022-11-28	單件重量 - (KG)	

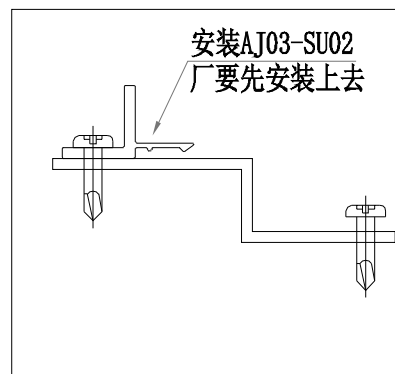
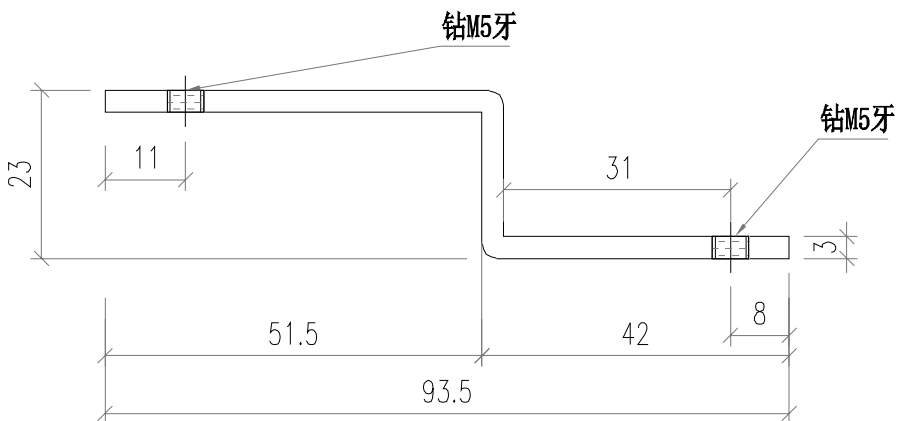
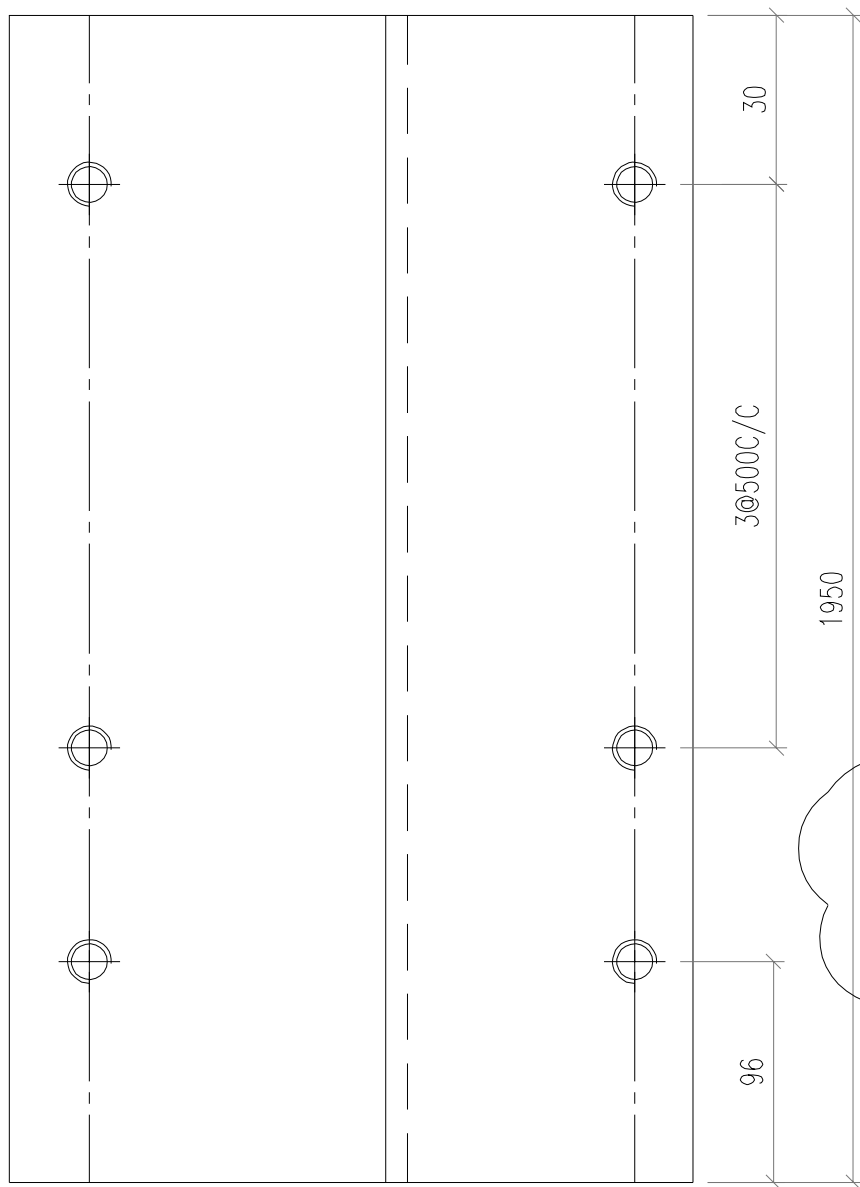

 美特鋁質有限公司 MIDI Aluminium Fabricator Ltd.				工程號 J856	類別 天榮站	物料號 M1	圖號 AX04-P03
修改 日期	採用 工廠	地盤 <input checked="" type="checkbox"/>	圖紙名稱 鋁料加工圖	制圖 李傳鵬	2022-11-26	數量 -	單件重量 - (KG)
	材料顏色 鉻化		材料 3MM鋁板	復核 練松文	2022-11-27		
				批准 林仁安	2022-11-28		

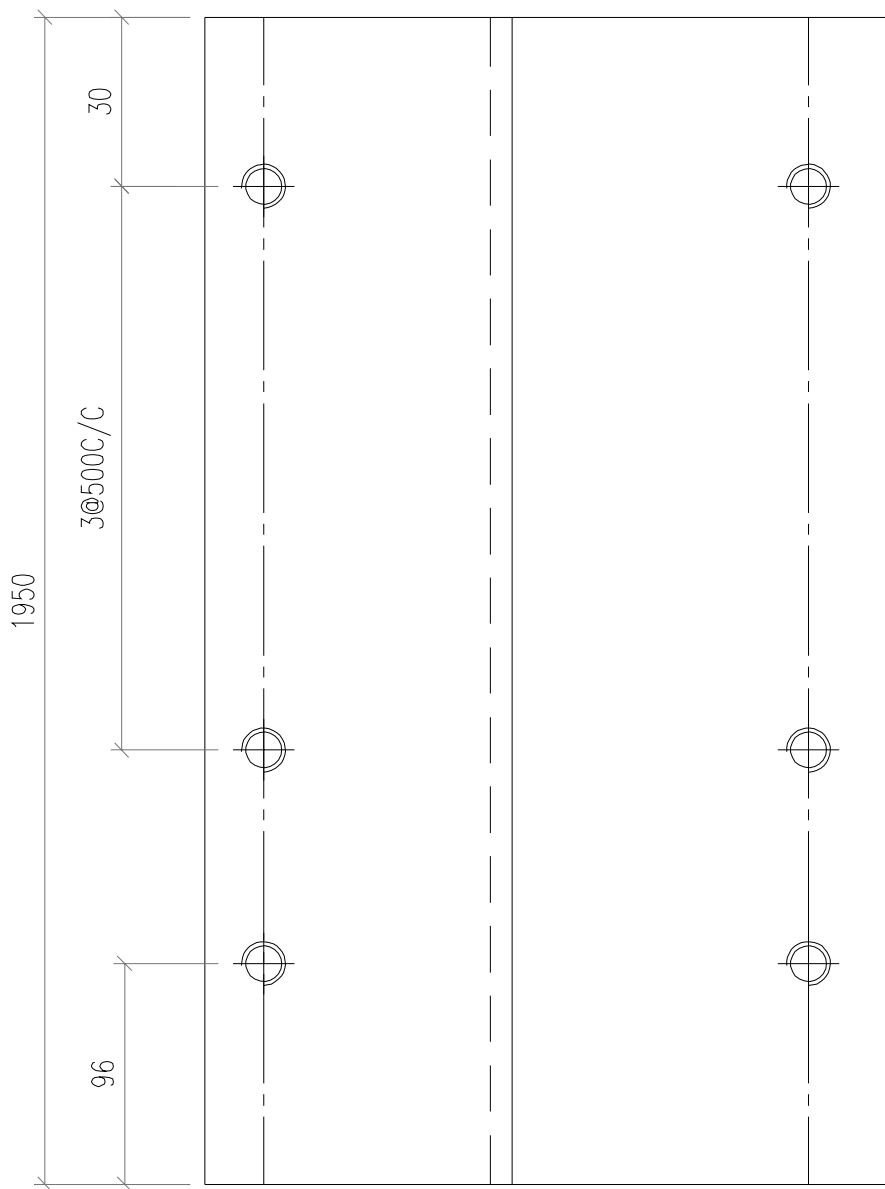

用鋁板折

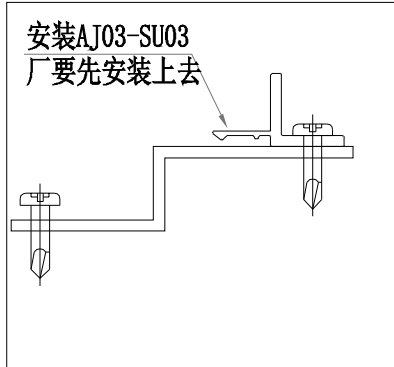
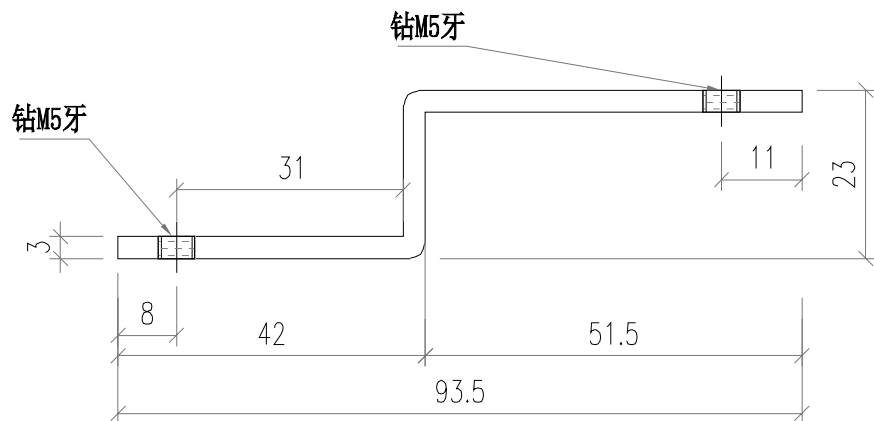

 美特鋁質有限公司 MIDI Aluminium Fabricator Ltd.				工程號 J856	類別 天榮站	物料號 M1	圖號 AC06-P01	
修改 -	日期 -	採用工廠 <input type="checkbox"/>	地盤 <input checked="" type="checkbox"/>	图纸名称 铝料加工图	制圖 李傳鵬	2022-11-26	數量 -	單件重量 - (KG)
		材料颜色 -	材料 AC06	復核 練松文	2022-11-27	2022-11-28		

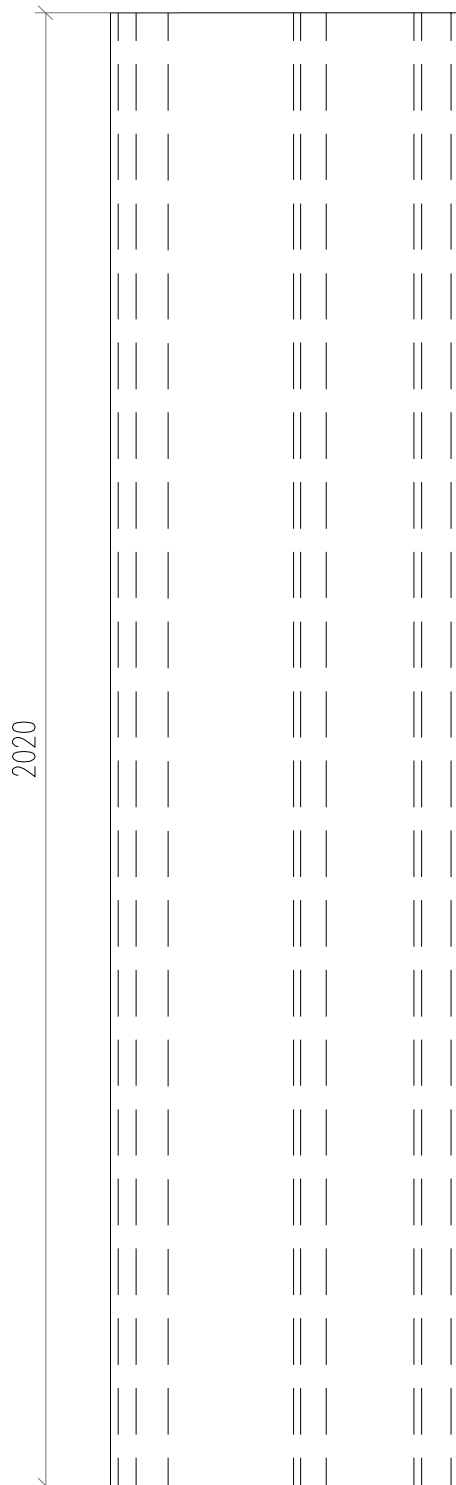

散出地盤

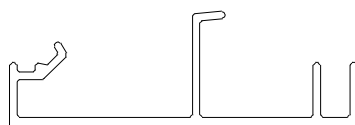

 美特鋁質有限公司 MIDI Aluminium Fabricator Ltd.				工程號	J856	類別		物料號	M1		
				地盘	天榮站	制圖	李傳鵬	2022-11-26	圖號	AC07-P01	
修改	-		採用工廠		地盘	✓	復核	練松文	2022-11-27	數量	-
日期	-		材料颜色	-	图纸名称	铝料加工图	批准	林仁安	2022-11-28	單件重量	- (KG)

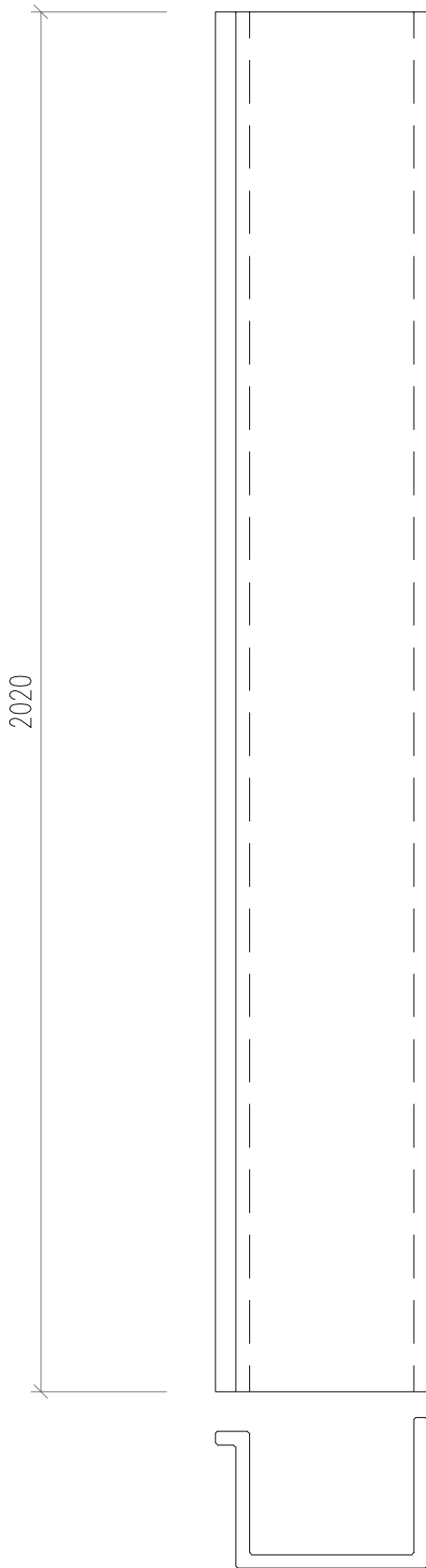

散出地盘

 美特鋁質有限公司 MIDI Aluminium Fabricator Ltd.		工程號 J856 地盘 天榮站	類別 制圖 李傳鵬 復核 練松文 批准 林仁安	物料號 M1 圖號 CE-001 數量 - 單件重量 - (KG)
修改日期 採用工廠 材料颜色 -	地盘 ✓ 图纸名称 开启扇组装图 材料 -			

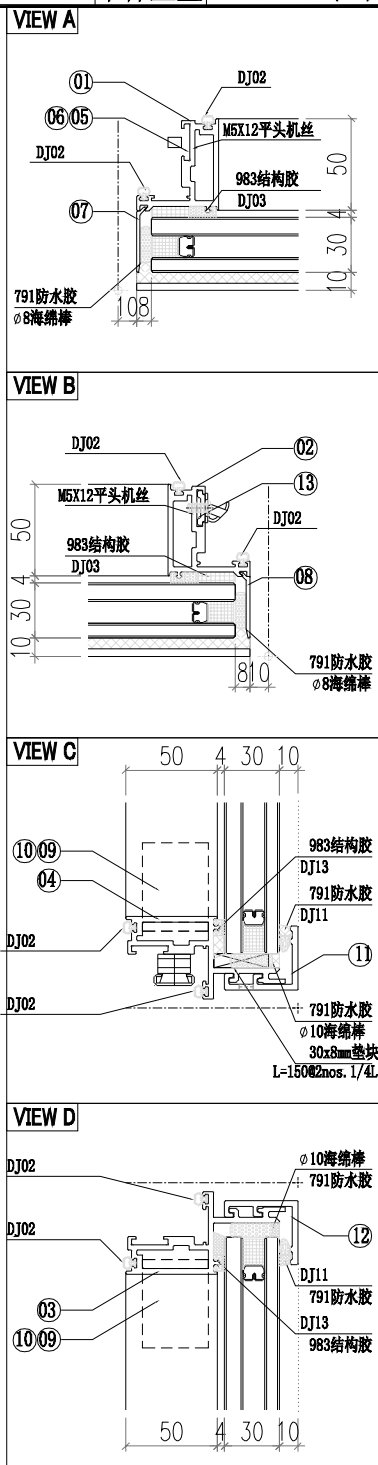
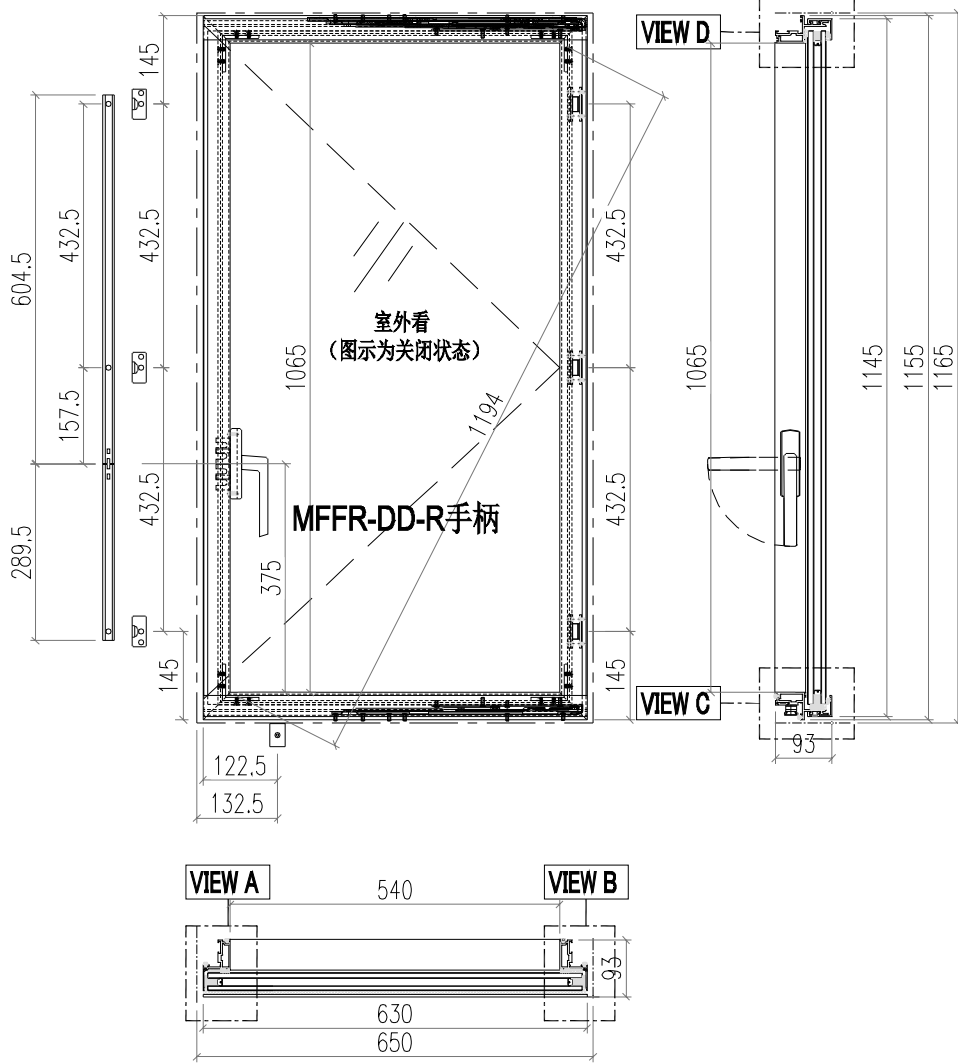

13	X86370-K01	X86370	55	3
12	X86412-E01	X86412	630	1
11	X86412-E02	X86412	630	1
10	JS01-Q02	60*60*5铝角	35	2
9	JS01-Q01	60*60*5铝角	35	2
8	AC02-E01R-1	AC02	1137	1
7	AC02-E01-1	AC02	1137	1
6	X86370-P01	X86370	604.5	1
5	X86370-P02	X86370	289.5	1
4	WS03-P04	WS03	630	1
3	WS03-P03	WS03	630	1
2	WS01-P01	WS01	1155	1
1	WS01-P03	WS01	1155	1
序号	加工图编号	材料名称	长度	支/幅

窗玉扇撑加LBB-1垫巴

 美特铝质有限公司 MIDI Aluminium Fabricator Ltd.		工程號 J856 地盘 天榮站	類別 制圖 李傳鵬 復核 練松文 批准 林仁安	物料號 M1 2022-11-25 2022-11-26 2022-11-28	圖號 CE-002 數量 - 單件重量 - (KG)
修改日期 採用工廠 地盤 <input checked="" type="checkbox"/>	材料颜色 -	图纸名称 开启扇组装图 材料 -			

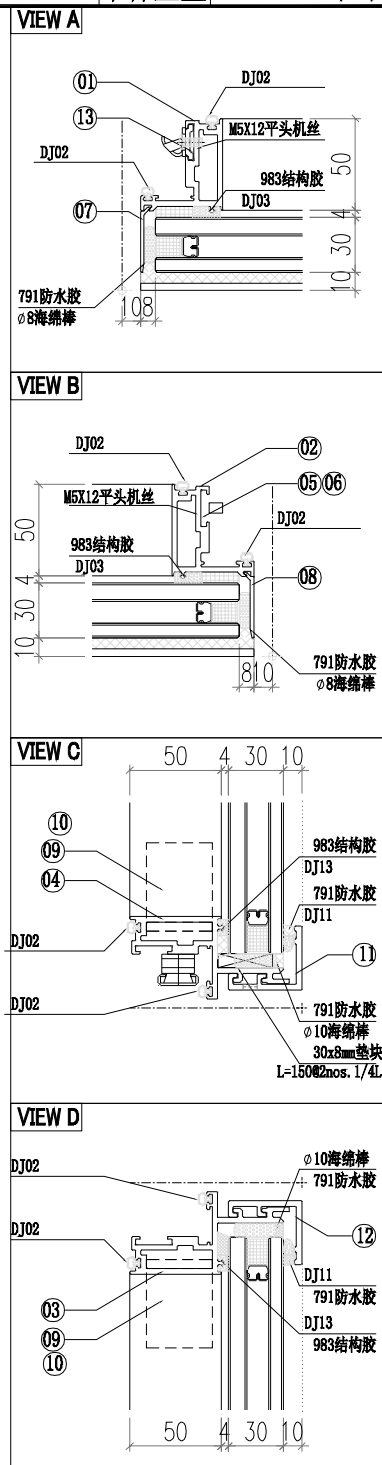
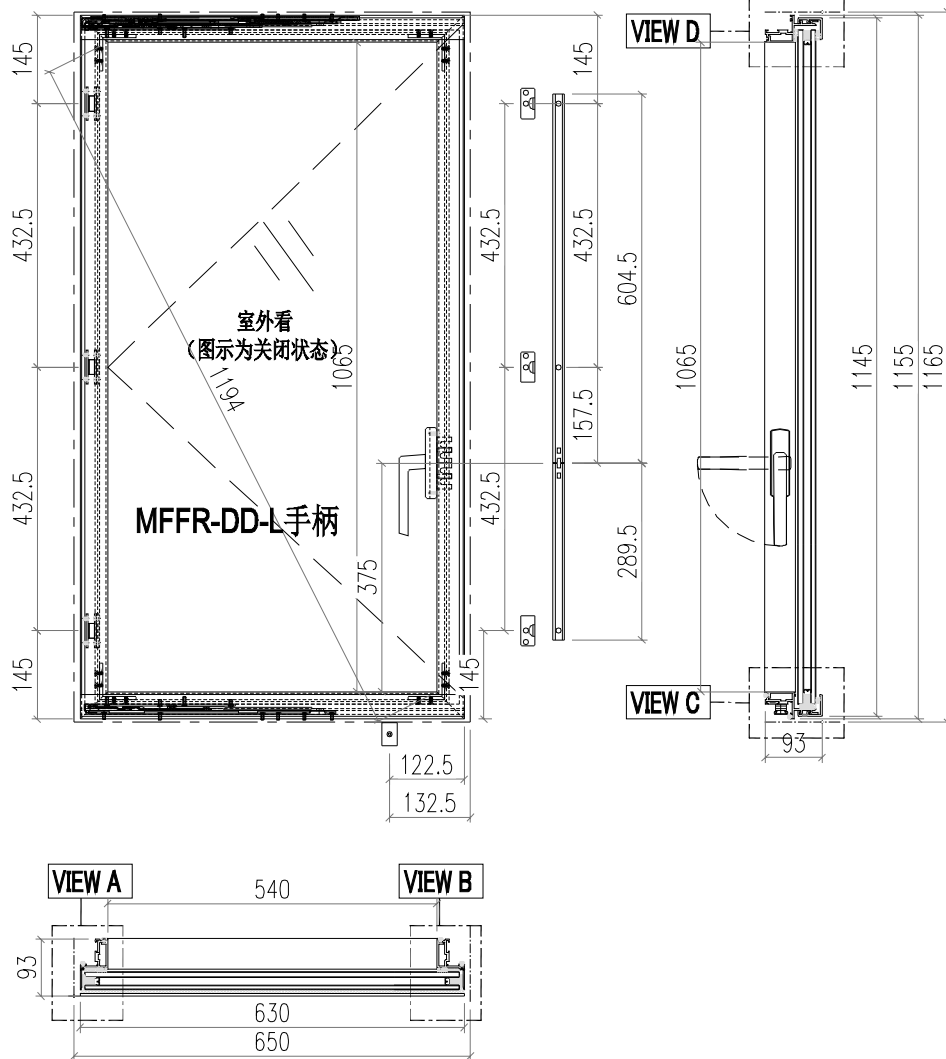

13	X86370-K01	X86370	55	3
12	X86412-E01	X86412	630	1
11	X86412-E02	X86412	630	1
10	JS01-Q02	60*60*5铝角	35	2
9	JS01-Q01	60*60*5铝角	35	2
8	AC02-E01R-1	AC02	1137	1
7	AC02-E01-1	AC02	1137	1
6	X86370-P01	X86370	604.5	1
5	X86370-P02	X86370	289.5	1
4	WS03-P02	WS03	630	1
3	WS03-P01	WS03	630	1
2	WS01-P01	WS01	1155	1
1	WS01-P02	WS01	1155	1
序号	加工图编号	材料名称	长度	支/幅

窗玉扇撑加LBB-1垫巴

 美特鋁質有限公司 MIDI Aluminium Fabricator Ltd.		工程號 J856 地盘 天榮站	類別 制圖 李傳鵬 復核 練松文 批准 林仁安	物料號 M1 圖號 CE-003 數量 - 單件重量 - (KG)
修改日期	採用工廠	地盘 <input checked="" type="checkbox"/>	图纸名称 开启扇组装图	
	材料颜色 -		材料 -	

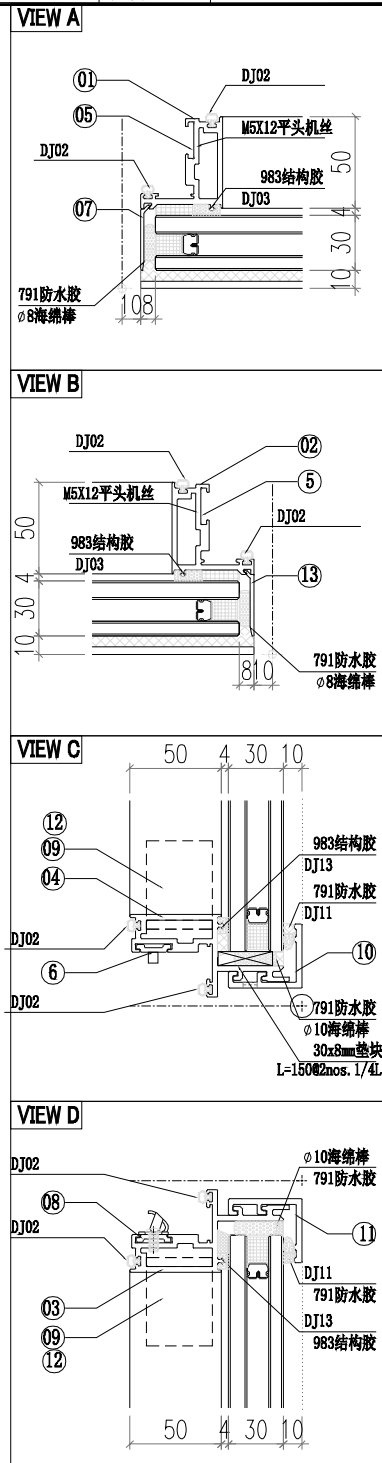
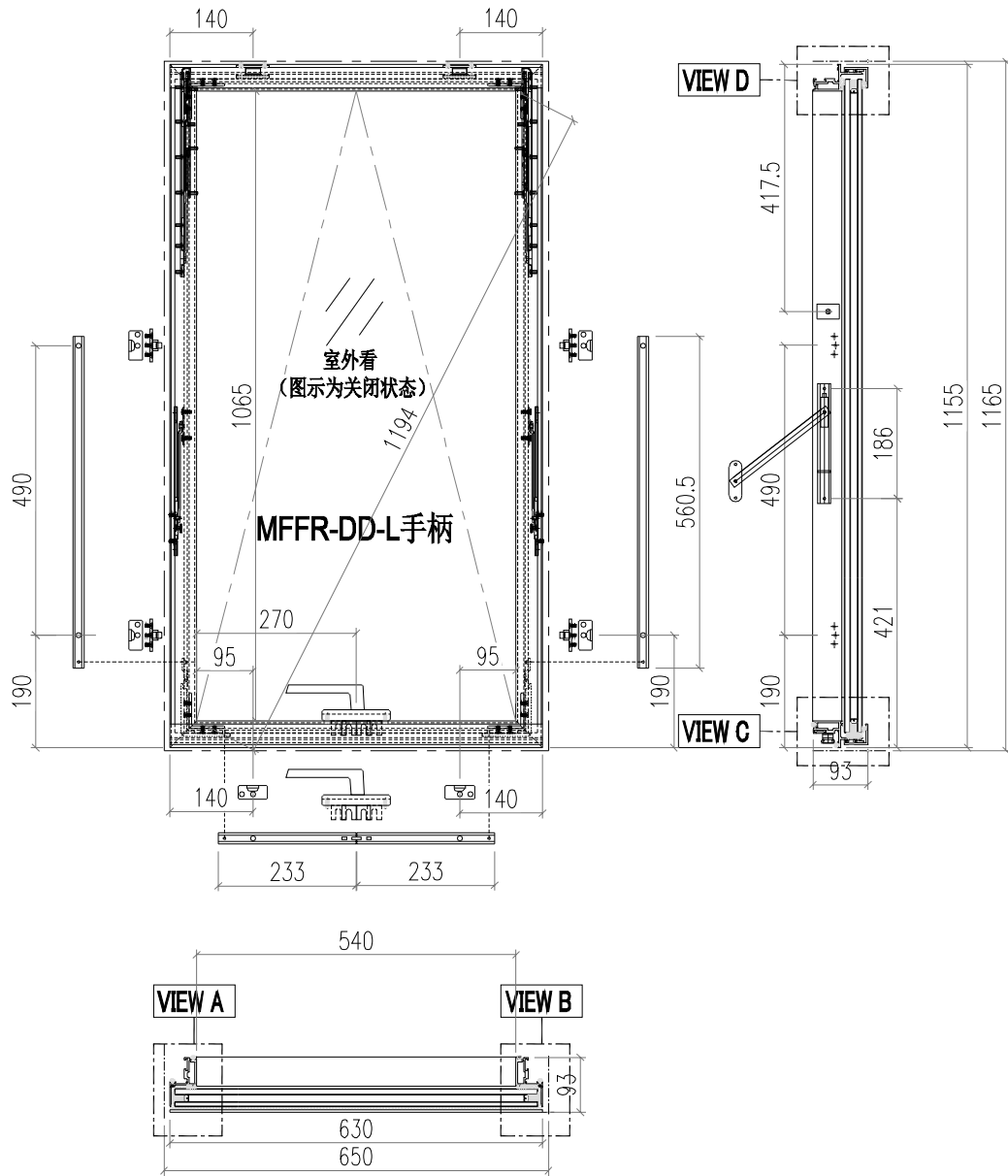

13	AC02-E01R-1	AC02	1137	1
12	JS01-Q02	60*60*5铝角	35	2
11	X86412-E01	X86412	630	1
10	X86412-E02	X86412	630	1
9	JS01-Q01	60*60*5铝角	35	2
8	X86370-K01	X86370	55	2
7	AC02-E01-1	AC02	1137	1
6	X86370-P04-01	X86370	233	2
5	X86370-P03	X86370	560.5	2
4	WS03-P06	WS03	630	1
3	WS03-P05	WS03	630	1
2	WS01-P05	WS01	1155	1
1	WS01-P04	WS01	1155	1
序号	加工图编号	材料名称	长度	支/幅

窗玉扇撑加LBB-1垫巴

 美特鋁質有限公司 MIDI Aluminium Fabricator Ltd.		工程號 J856 地盘 天榮站	類別 制圖 李傳鵬 復核 練松文 批准 林仁安	物料號 M1 2022-11-25 2022-11-26 2022-11-28	圖號 CE-011 數量 - 單件重量 - (KG)
修改日期 採用工廠 地盤 <input checked="" type="checkbox"/>	材料顏色 -	图纸名称 开启扇组装图 材料 -			

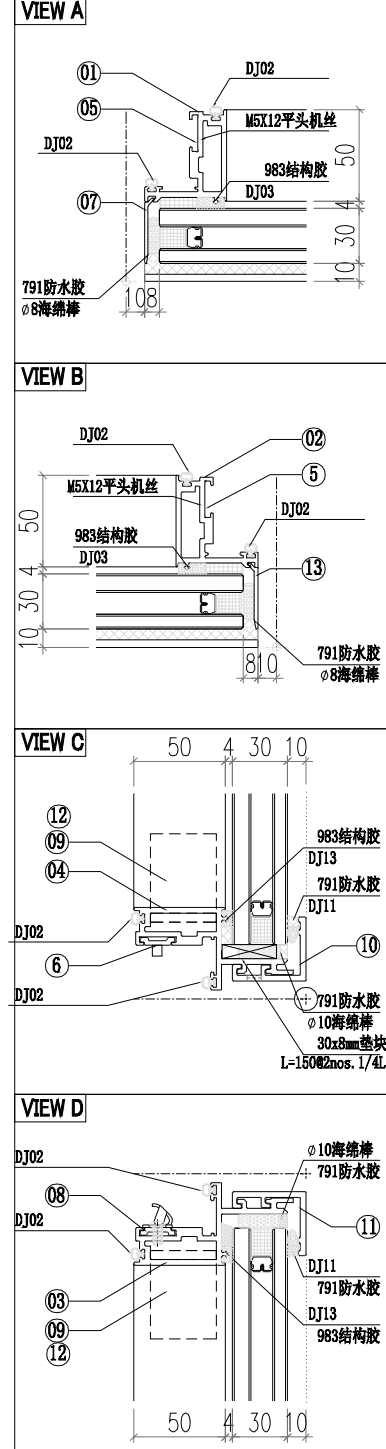
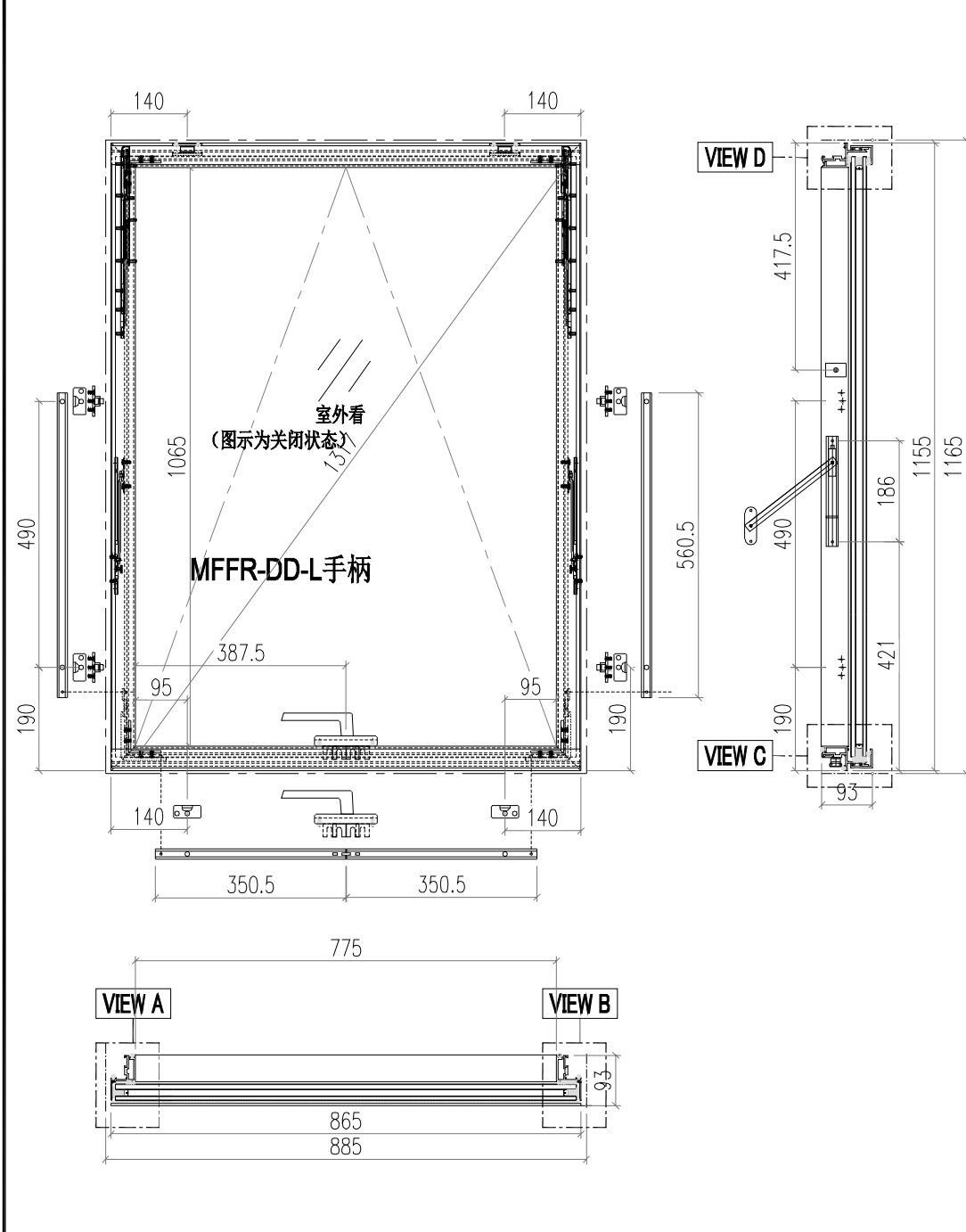

13	AC02-E01R-1	AC02	1137	1
12	JS01-Q02	60*60*5铝角	35	2
11	X86412-E01-2	X86412	865	1
10	X86412-E02-2	X86412	865	1
9	JS01-Q01	60*60*5铝角	35	2
8	X86370-K01	X86370	55	2
7	AC02-E01-1	AC02	1137	1
6	X86370-P04-05	X86370	350.5	2
5	X86370-P03	X86370	560.5	2
4	WS03-P12	WS03	865	1
3	WS03-P11	WS03	865	1
2	WS01-P05	WS01	1155	1
1	WS01-P04	WS01	1155	1
序号	加工图编号	材料名称	长度	支/幅

窗玉扇撑加LBB-1垫巴

 美特鋁質有限公司 MIDI Aluminium Fabricator Ltd.		工程號 J856 地盘 天榮站	類別 制圖 李傳鵬 復核 練松文 批准 林仁安	物料號 M1 圖號 CE-012 數量 - 單件重量 - (KG)
修改日期 採用工廠 材料颜色 -	地盤 ✓ 图纸名称 开启扇组装图 材料 -			

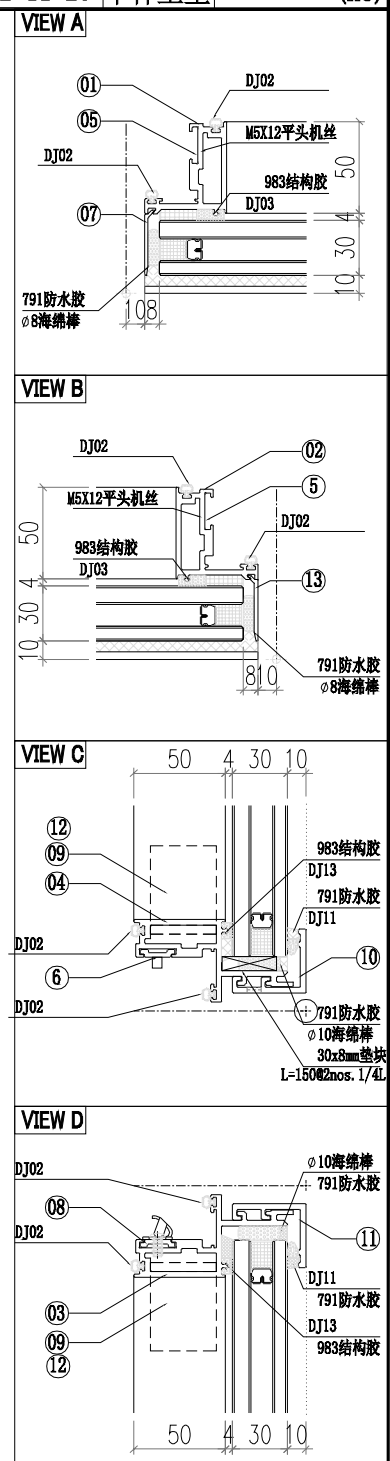
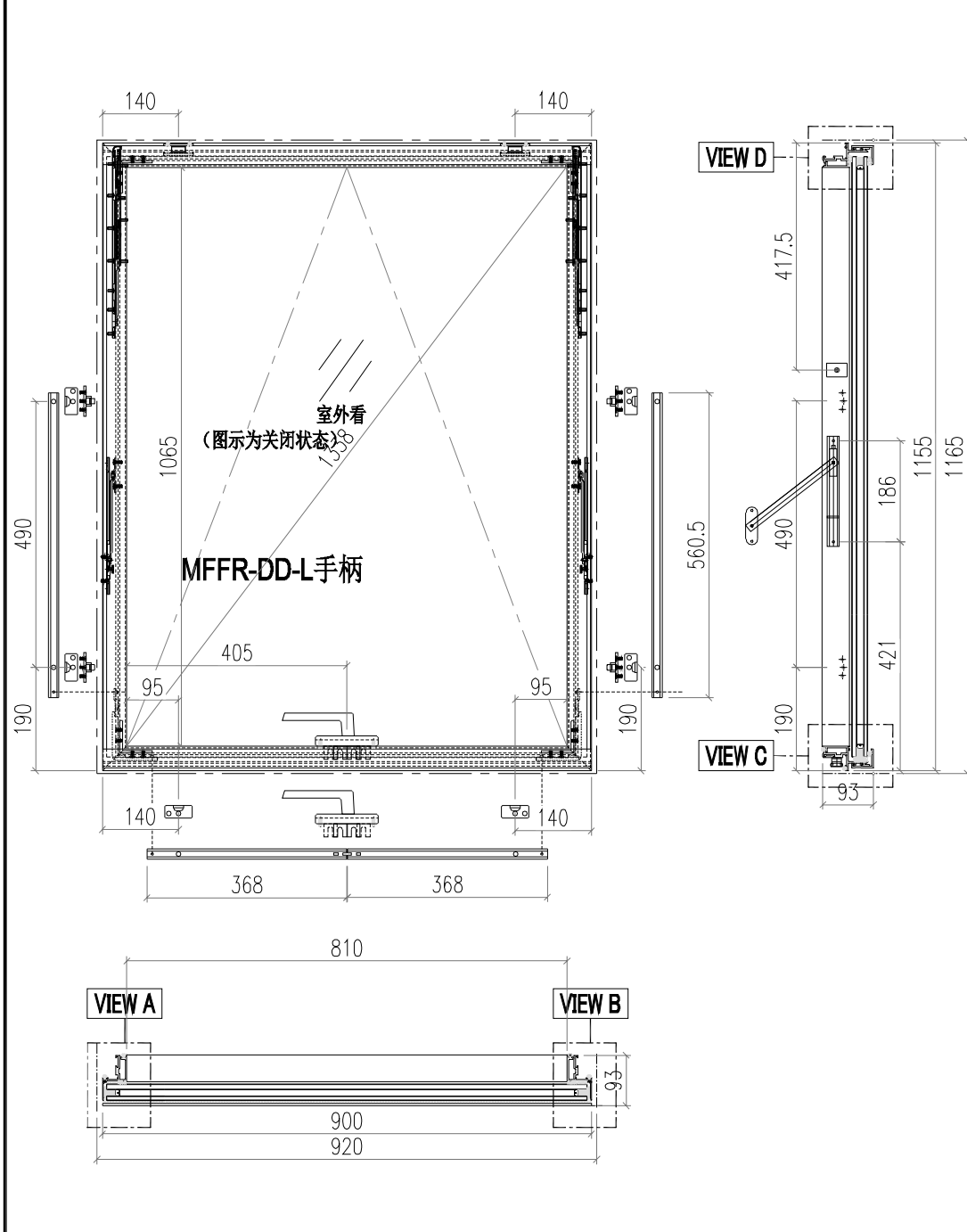

13	AC02-E01R-1	AC02	1137	1
12	JS01-Q02	60*60*5铝角	35	2
11	X86412-E01-3	X86412	900	1
10	X86412-E02-3	X86412	900	1
9	JS01-Q01	60*60*5铝角	35	2
8	X86370-K01	X86370	55	2
7	AC02-E01-1	AC02	1137	1
6	X86370-P04-06	X86370	368	2
5	X86370-P03	X86370	560.5	2
4	WS03-P14	WS03	900	1
3	WS03-P13	WS03	900	1
2	WS01-P05	WS01	1155	1
1	WS01-P04	WS01	1155	1
序号	加工图编号	材料名称	长度	支/幅

窗玉扇撑加LBB-1垫巴

 美特鋁質有限公司 MIDI Aluminium Fabricator Ltd.		工程號 J856 地盘 天榮站	類別 制圖 李傳鵬 復核 練松文 批准 林仁安	物料號 M1 圖號 CE-013 數量 - 單件重量 - (KG)
修改日期 採用工廠 材料颜色 -	地盤 ✓ 图纸名称 开启扇组装图 材料 -			

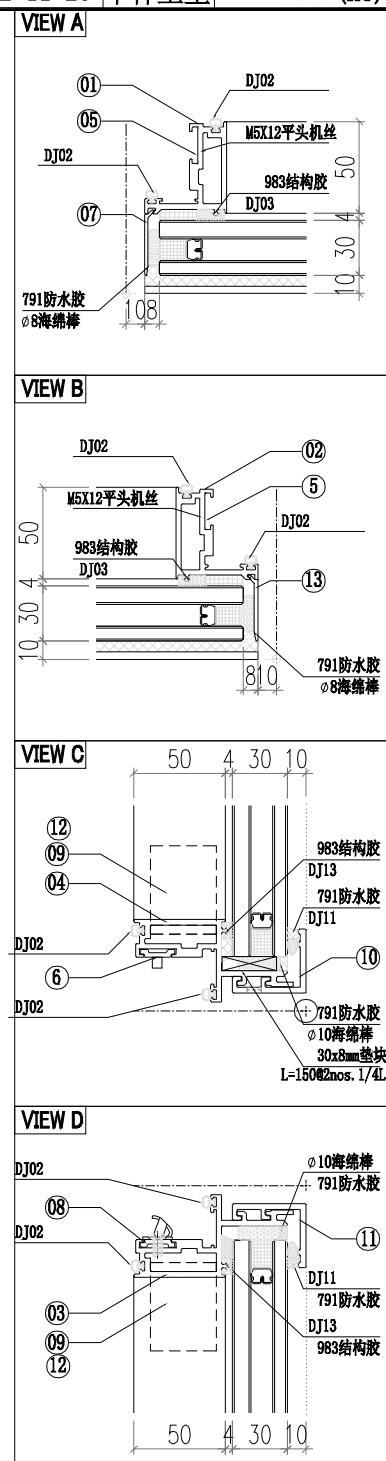
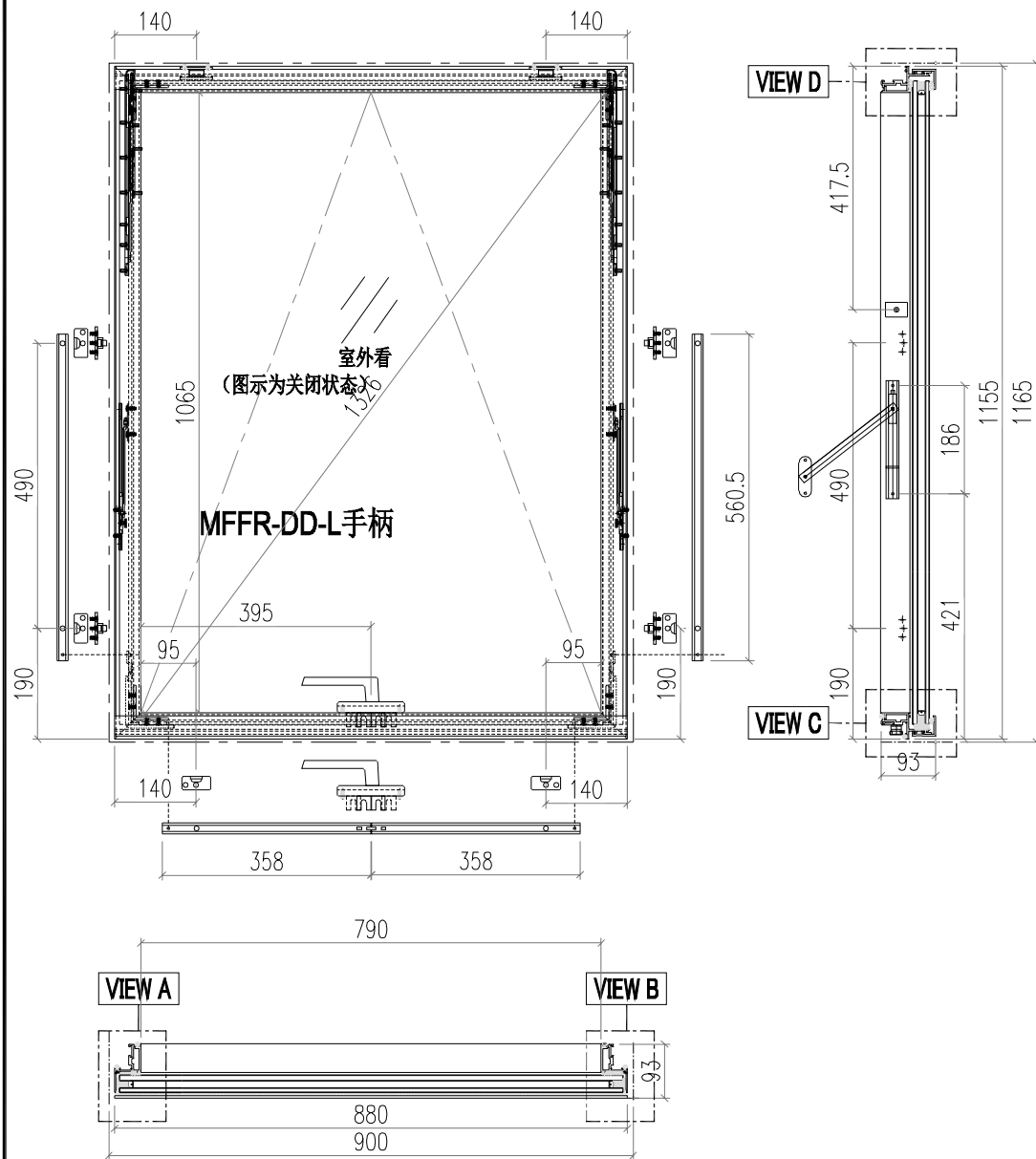

13	AC02-E01R-1	AC02	1137	1
12	JS01-Q02	60*60*5铝角	35	2
11	X86412-E01-4	X86412	880	1
10	X86412-E02-4	X86412	880	1
9	JS01-Q01	60*60*5铝角	35	2
8	X86370-K01	X86370	55	2
7	AC02-E01-1	AC02	1137	1
6	X86370-P04-07	X86370	358	2
5	X86370-P03	X86370	560.5	2
4	WS03-P16	WS03	880	1
3	WS03-P15	WS03	880	1
2	WS01-P05	WS01	1155	1
1	WS01-P04	WS01	1155	1
序号	加工图编号	材料名称	长度	支/幅

窗玉扇撑加LBB-1垫巴

 美特鋁質有限公司 MIDI Aluminium Fabricator Ltd.			工程號 J856 地盘 天榮站	類別 制圖 李傳鵬 復核 練松文 批准 林仁安	物料號 M1 圖號 WS01-P01 數量 - 單件重量 - (KG)
修改 日期	採用工廠 材料顏色 -	地盘 ✓	图纸名称 铝料加工图 材料 WS01		

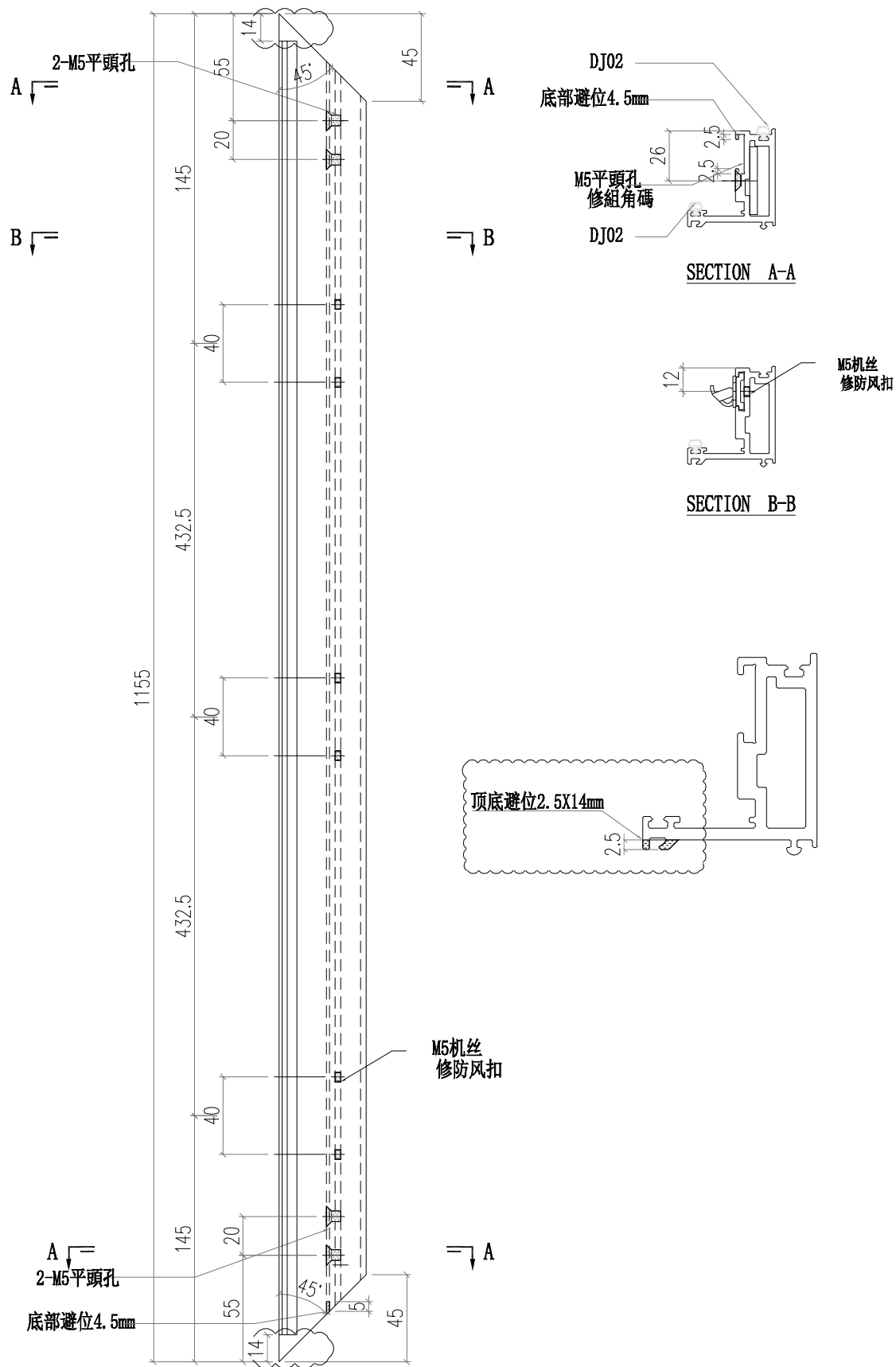

 美特鋁質有限公司 MIDI Aluminium Fabricator Ltd.			工程號 J856 地盘 天榮站	類別 制圖 李傳鵬 復核 練松文 批准 林仁安	物料號 M1 2022-11-25 2022-11-26 2022-11-28	圖號 WS01-P02 數量 - 單件重量 - (KG)
修改 日期	採用工廠 材料顏色 -	地盘 ✓	图纸名称 铝料加工图 材料 WS01			

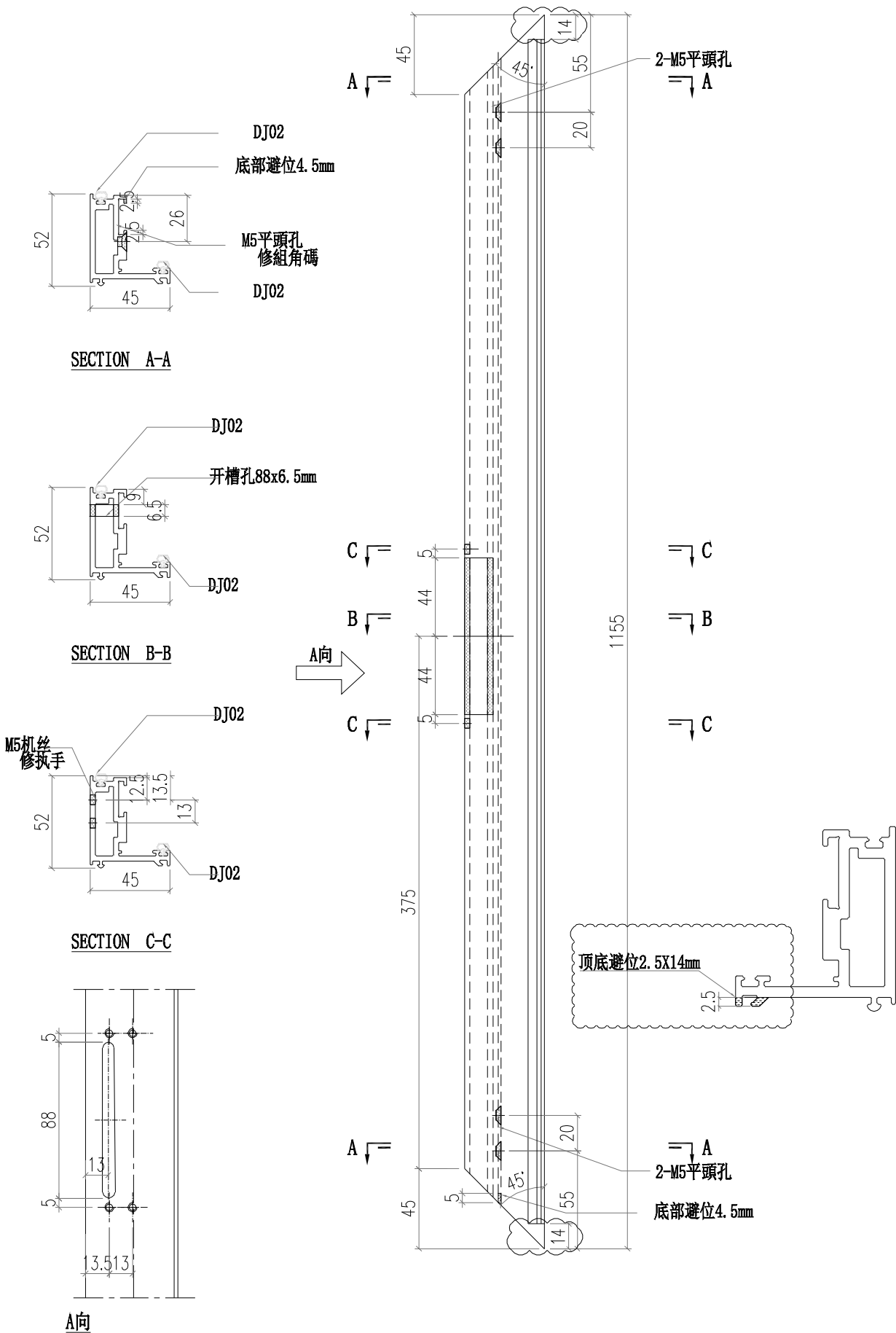

 美特鋁質有限公司 MIDI Aluminium Fabricator Ltd.			工程號 J856 地盘 天榮站	類別 制圖 李傳鵬 復核 練松文 批准 林仁安	物料號 M1 圖號 WS01-P03 數量 - 單件重量 - (KG)
修改日期 採用工廠 材料颜色 -	地盘 ✓ 图纸名称 铝料加工图 材料 WS01				

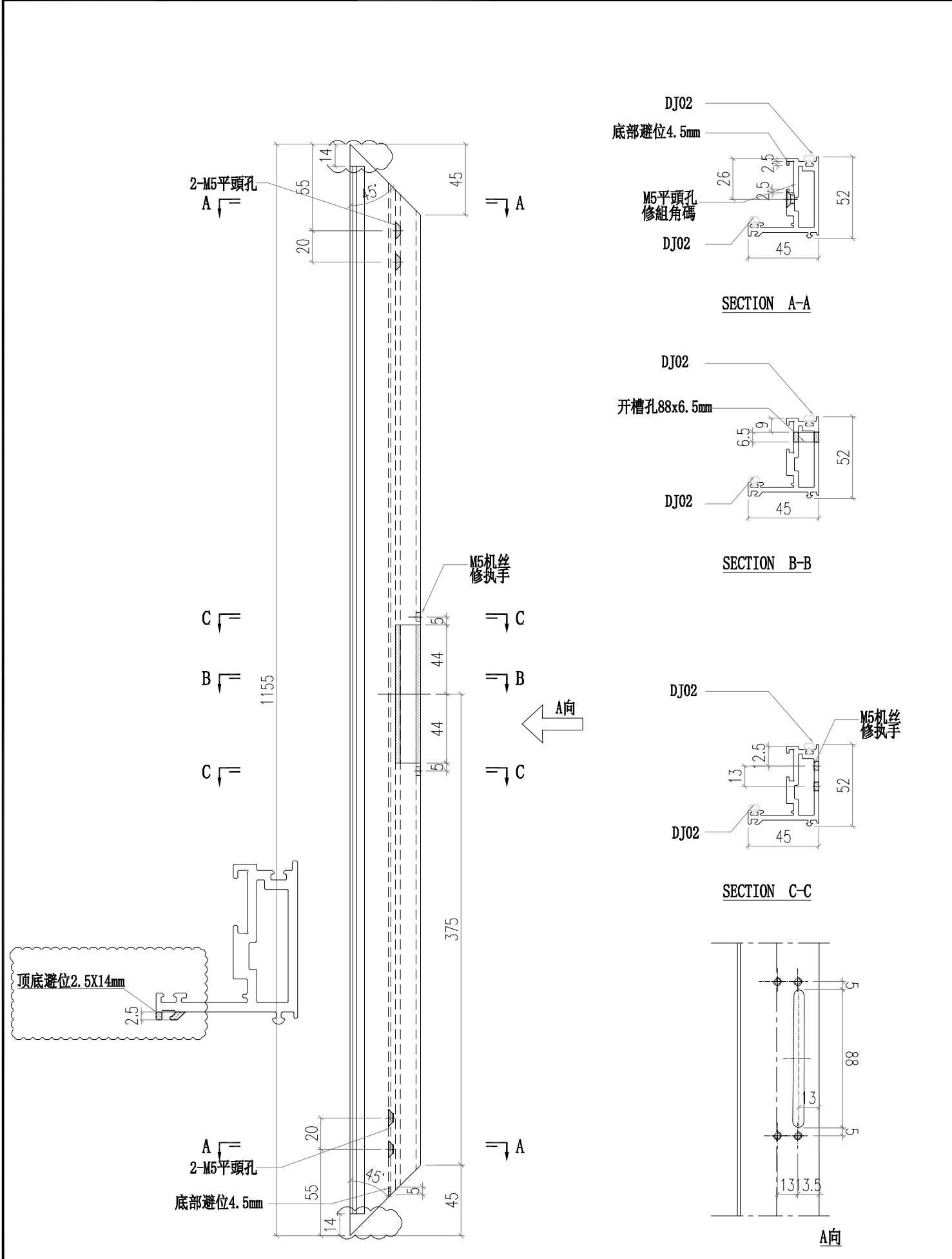

 美特鋁質有限公司 MIDI Aluminium Fabricator Ltd.			工程號 J856 地盤 天榮站	類別 制圖 李傳鵬 復核 練松文 批准 林仁安	物料號 M1 圖號 WS01-P04 數量 - 單件重量 - (KG)
修改 日期	採用工廠 材料顏色 -	地盤 ✓	图纸名称 铝料加工图 材料 WS01		

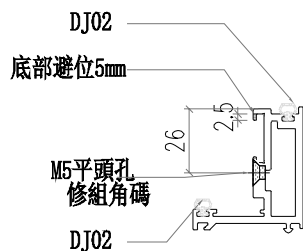
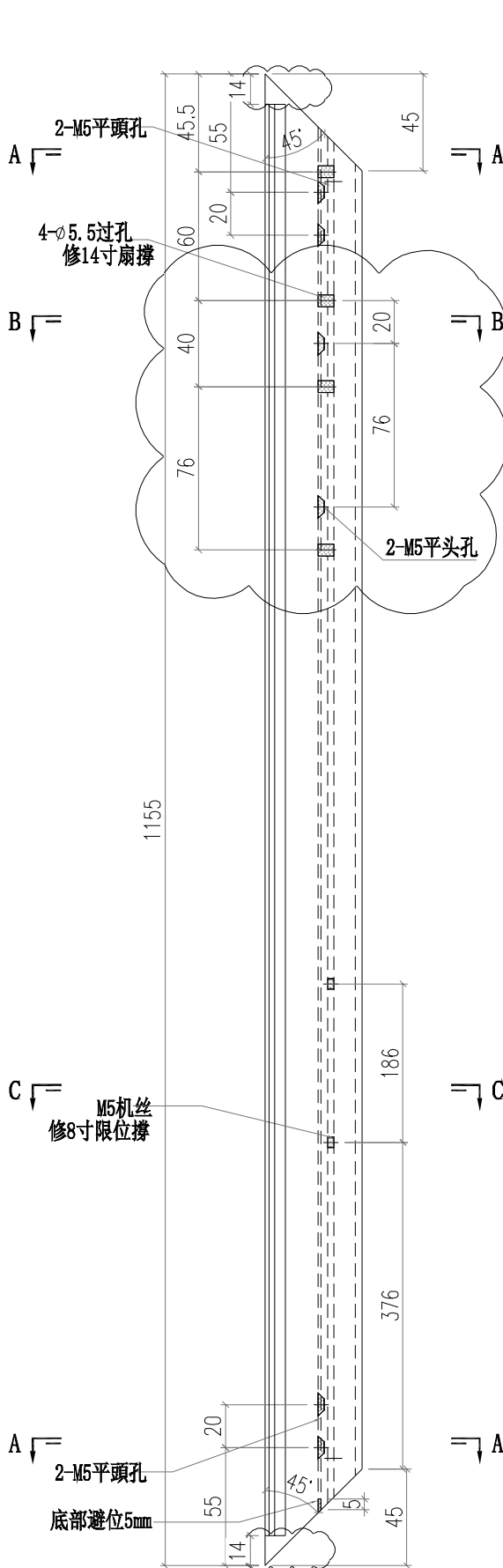

SECTION A-A

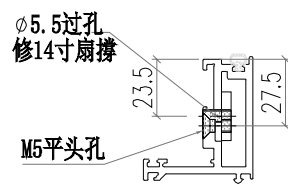

SECTION B-B

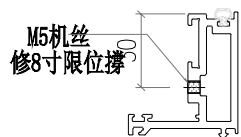

SECTION C-C

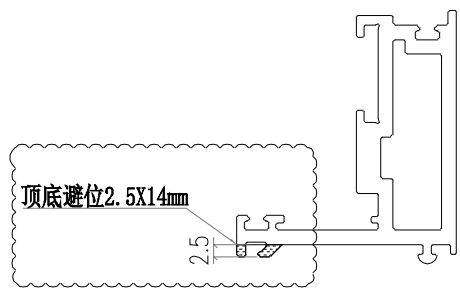

 美特鋁質有限公司 MIDI Aluminium Fabricator Ltd.			工程號 J856 地盘 天榮站	類別 制圖 李傳鵬 復核 練松文 批准 林仁安	物料號 M1 2022-11-25 2022-11-26 2022-11-28	圖號 WS03-P01 數量 - 單件重量 - (KG)
修改 日期	採用工廠 材料顏色 -	地盘 ✓	图纸名称 铝料加工图 材料 WS03			

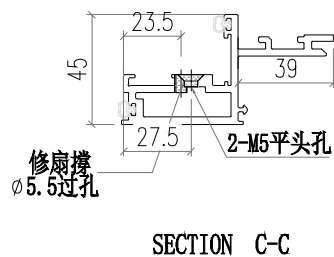
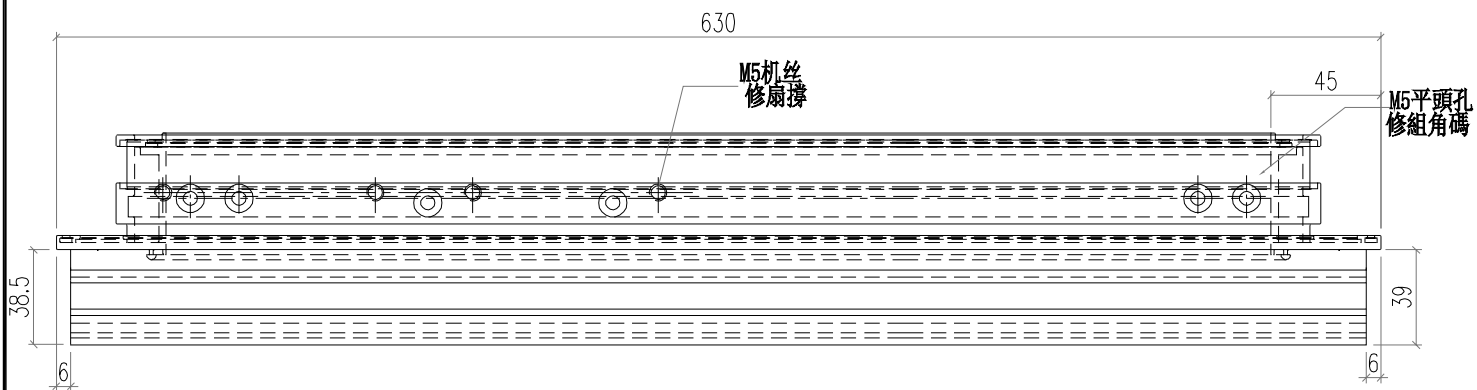
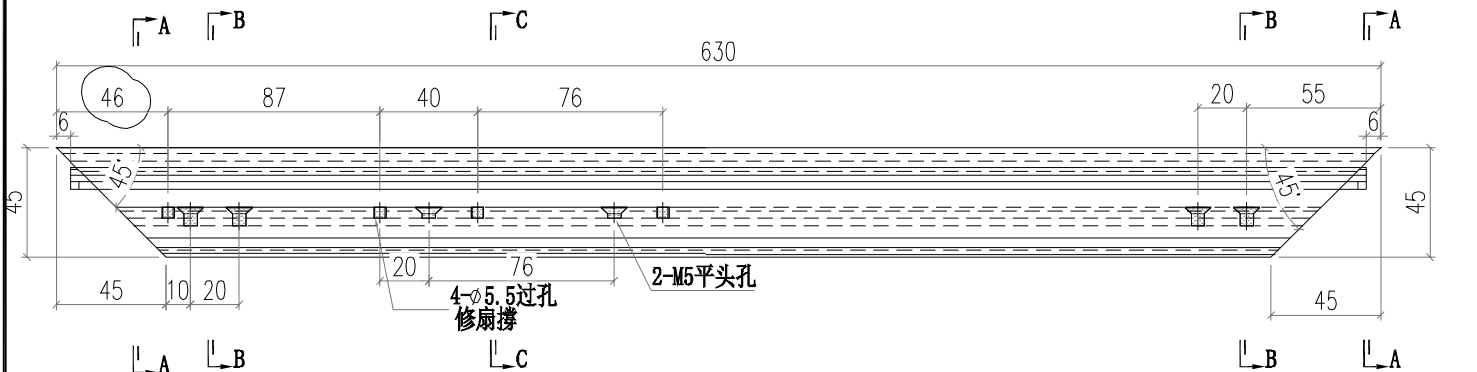
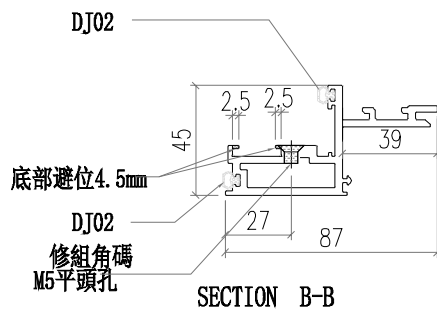
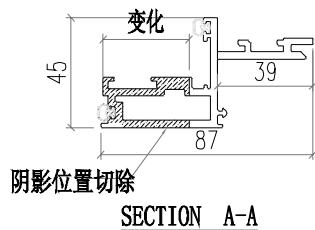

 美特鋁質有限公司 MIDI Aluminium Fabricator Ltd.			工程號 J856 地盘 天榮站	類別 制圖 李傳鵬 復核 練松文 批准 林仁安	物料號 M1 圖號 WS03-P02 數量 - 單件重量 - (KG)
修改 日期	採用工廠 材料顏色 -	地盘 ✓ 图纸名称 铝料加工图 材料 WS03			

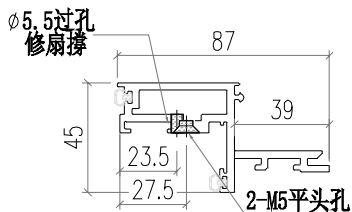

SECTION C-C

SECTION D-D

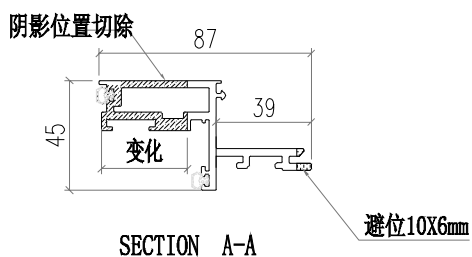
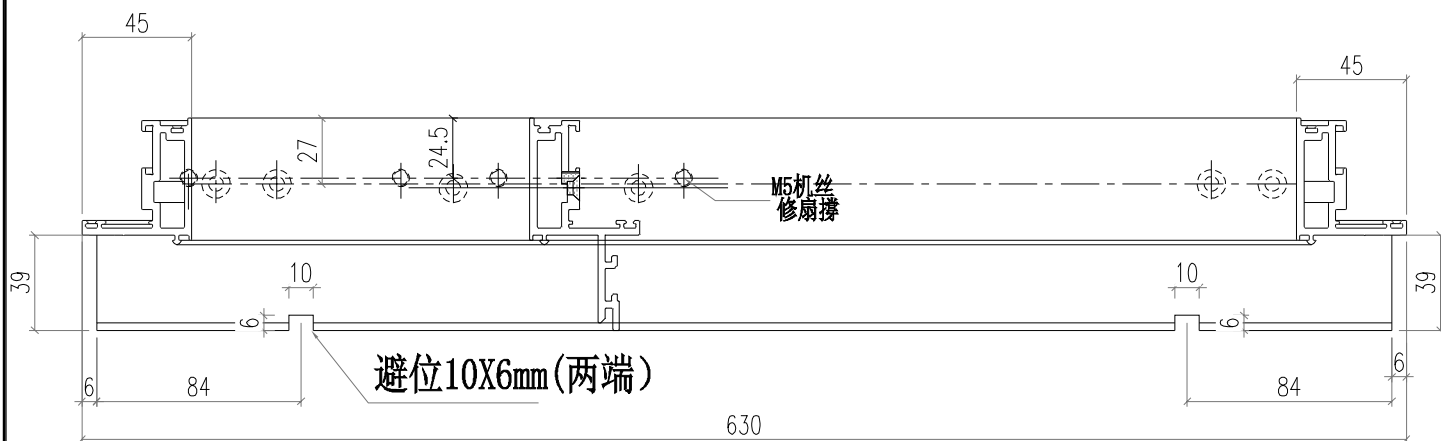
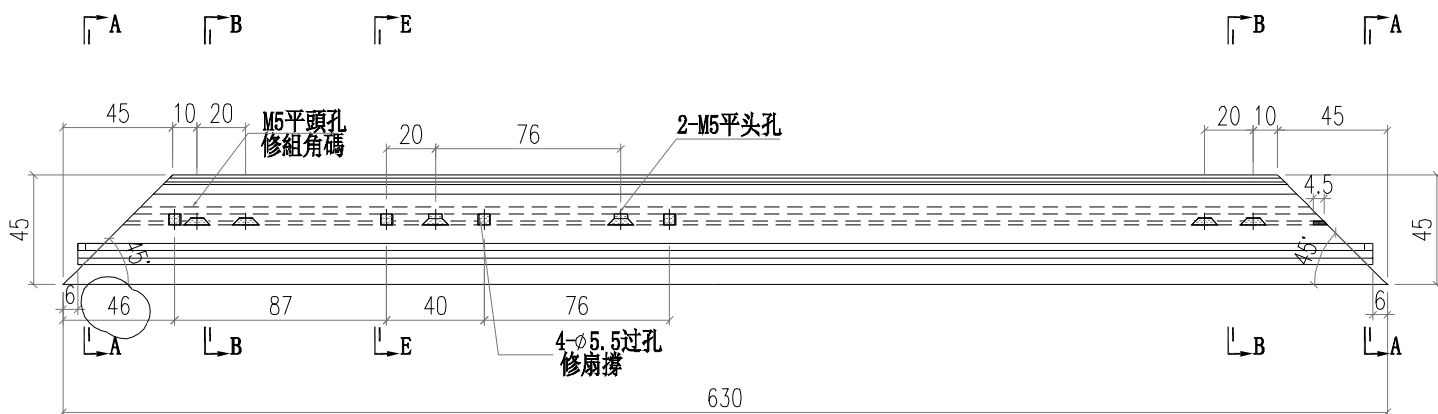

SECTION A-A

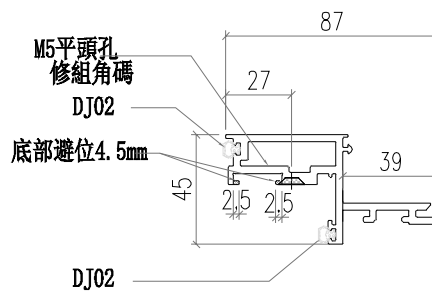

SECTION B-B

 美特鋁質有限公司 MIDI Aluminium Fabricator Ltd.			工程號 J856 地盘 天榮站	類別 制圖 李傳鵬 復核 練松文 批准 林仁安	物料號 M1 2022-11-25 2022-11-26 2022-11-28	圖號 WS03-P03 數量 - 單件重量 - (KG)
修改 日期	採用工廠 材料顏色 -	地盤 ✓	图纸名称 铝料加工图 材料 WS03			

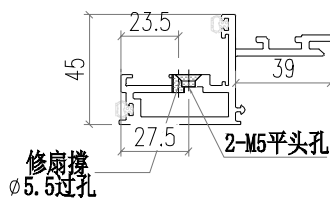
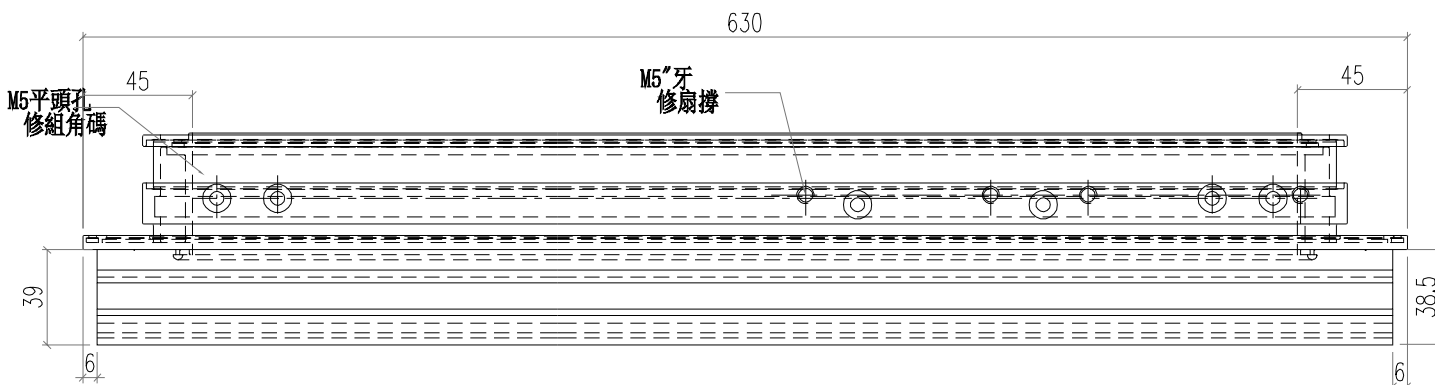
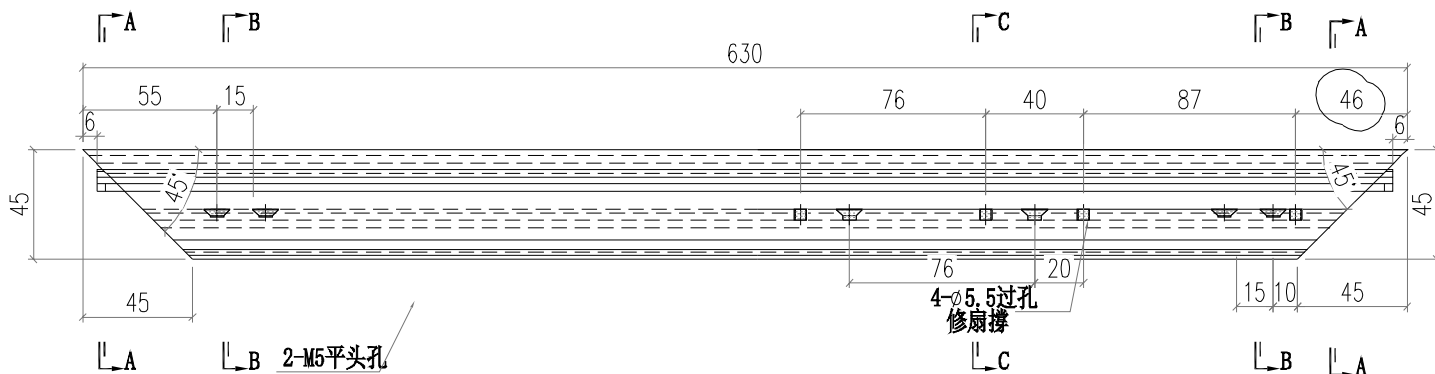
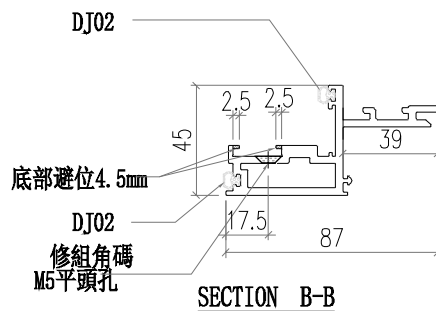
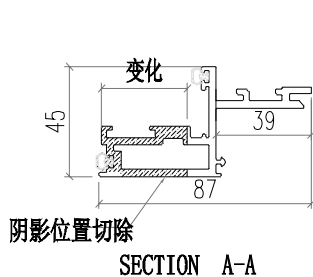

 美特鋁質有限公司 MIDI Aluminium Fabricator Ltd.			工程號 J856 地盘 天榮站	類別 制圖 李傳鵬 復核 練松文 批准 林仁安	物料號 M1 2022-11-25 2022-11-26 2022-11-28	圖號 WS03-P04 數量 - 單件重量 - (KG)
修改 日期	採用工廠 材料颜色 -	地盤 <input checked="" type="checkbox"/>	图纸名称 铝料加工图 材料 WS03			

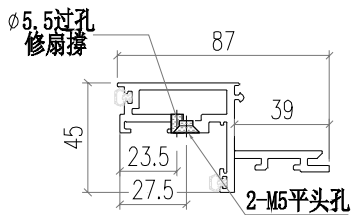

SECTION C-C

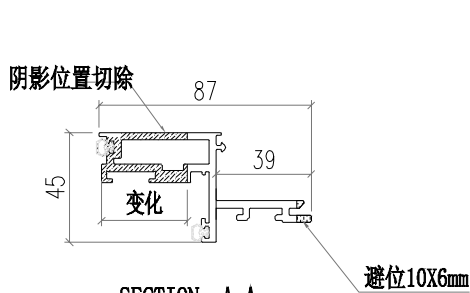
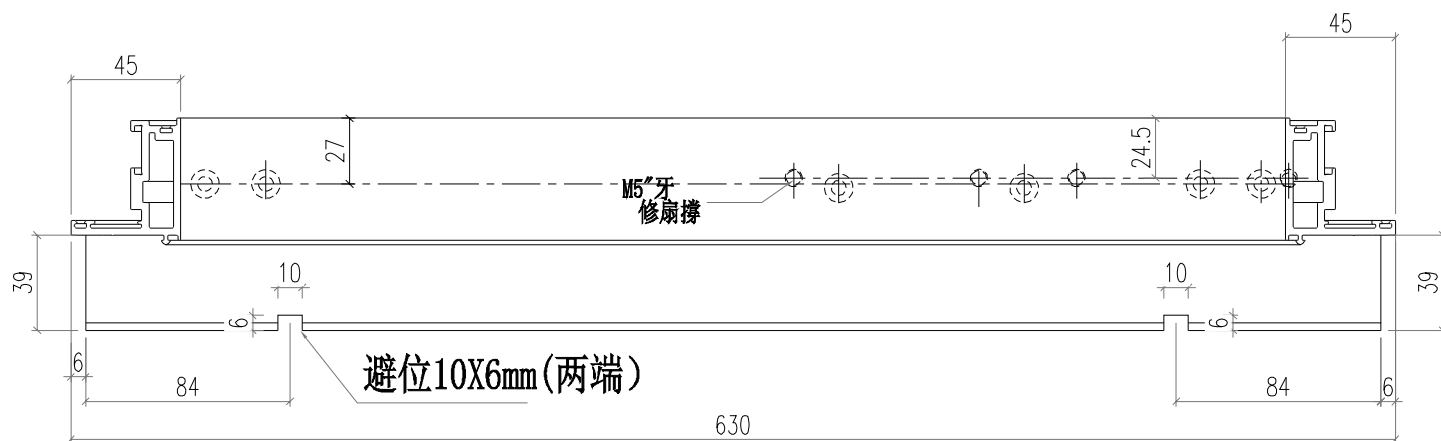
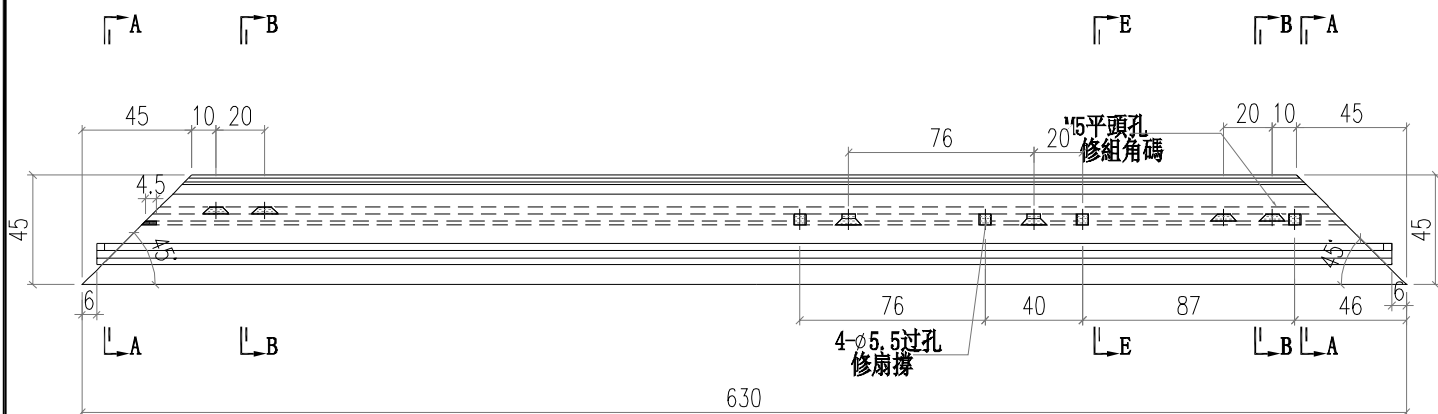

SECTION A-A

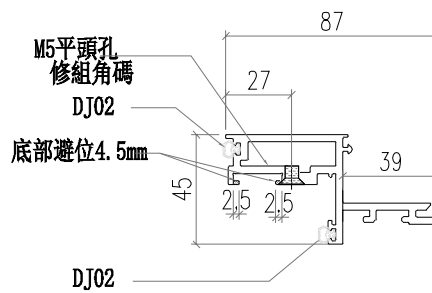

SECTION B-B

 美特鋁質有限公司 MIDI Aluminium Fabricator Ltd.			工程號 J856 地盘 天榮站	類別 制圖 李傳鵬 復核 練松文 批准 林仁安	物料號 M1 圖號 WS03-P05 數量 - 單件重量 - (KG)
修改日期 日期	採用工廠 材料颜色 -	地盤 ✓	图纸名称 铝料加工图 材料 WS03	物料號 M1 圖號 WS03-P05 數量 - 單件重量 - (KG)	

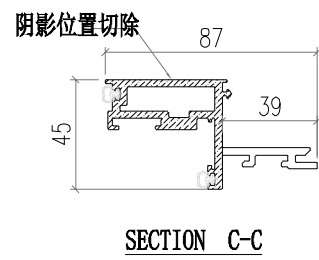
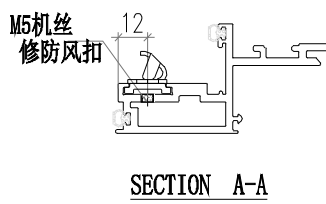
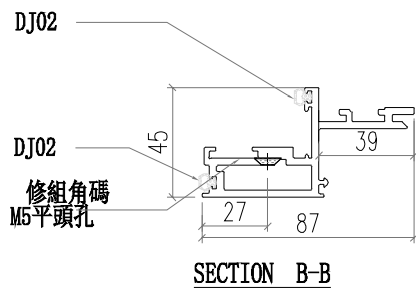
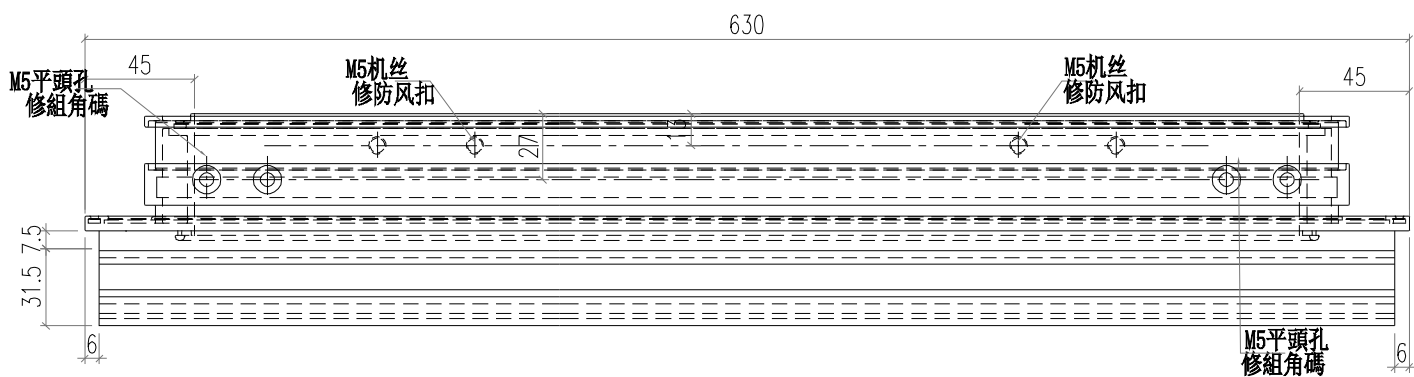
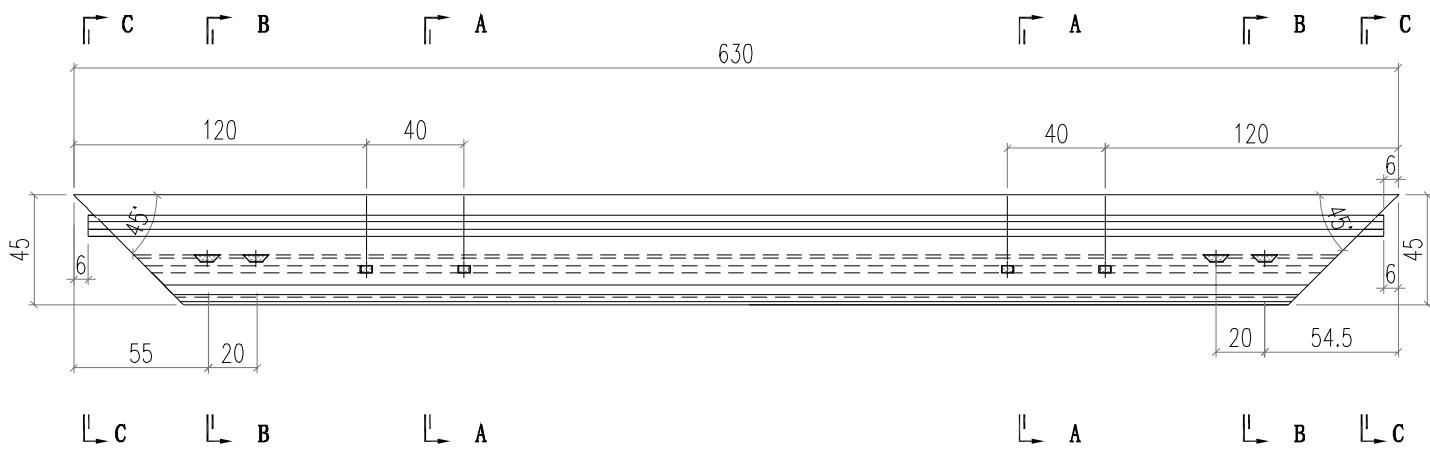

 美特鋁質有限公司 MIDI Aluminium Fabricator Ltd.			工程號 J856 地盘 天榮站	類別 制圖 李傳鵬 復核 練松文 批准 林仁安	物料號 M1 圖號 WS03-P06 數量 - 單件重量 - (KG)
修改日期 採用工廠 材料颜色 -	地盘 ✓ 图纸名称 铝料加工图 材料 WS03				

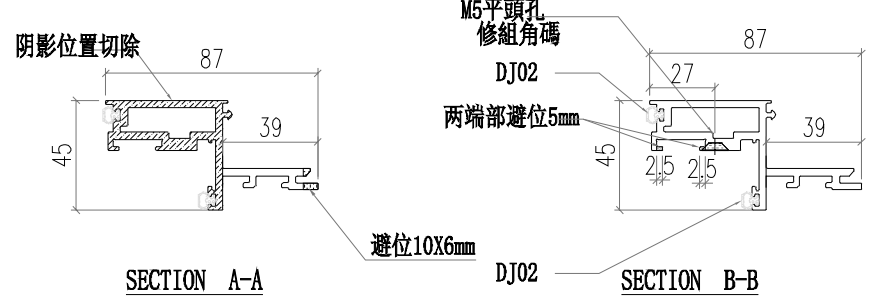
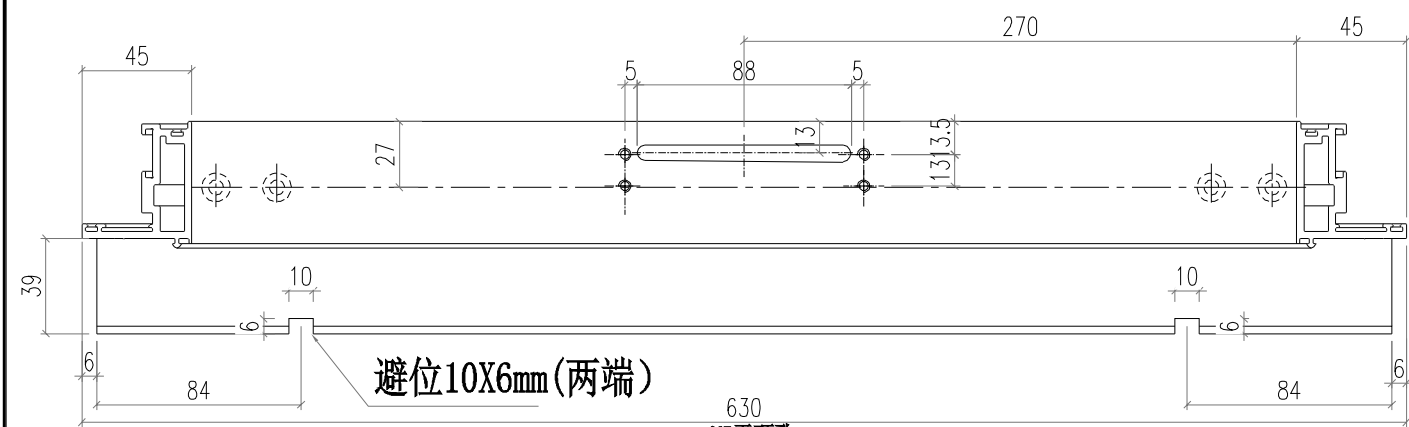
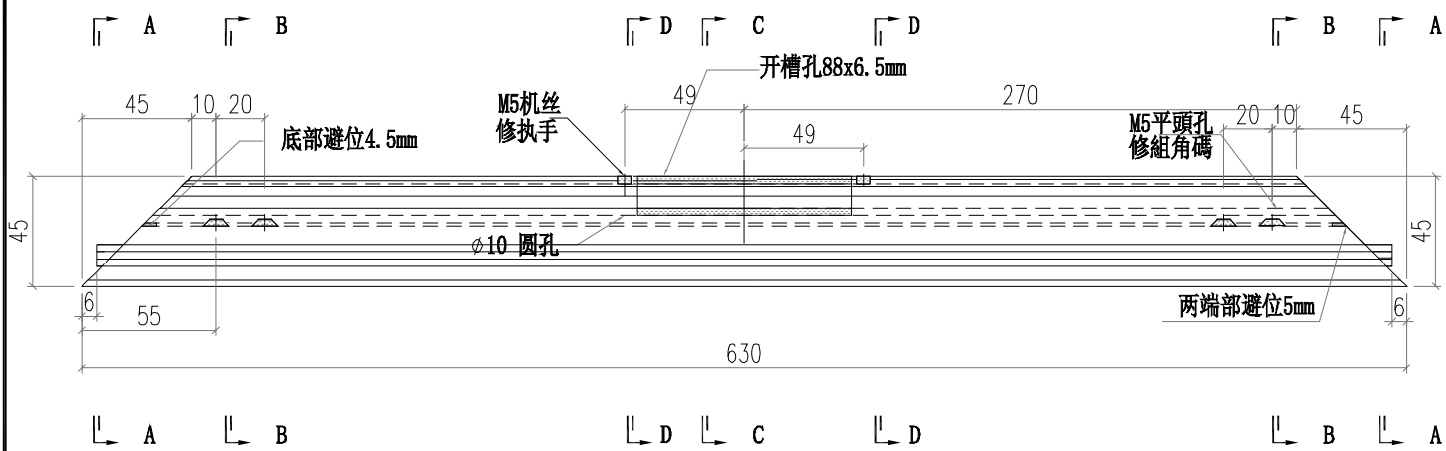
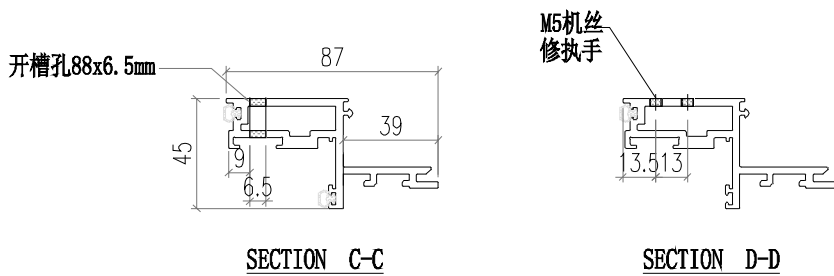

 美特鋁質有限公司 MIDI Aluminium Fabricator Ltd.			工程號 J856 地盘 天榮站	類別 制圖 李傳鵬 復核 練松文 批准 林仁安	物料號 M1 圖號 WS03-P11 數量 - 單件重量 - (KG)
修改 日期	採用工廠 材料顏色 -	地盘 ✓	图纸名称 铝料加工图 材料 WS03	日期 2022-11-25 日期 2022-11-26 日期 2022-11-28	圖號 WS03-P11 數量 - 單件重量 - (KG)

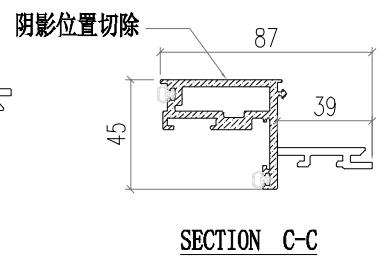
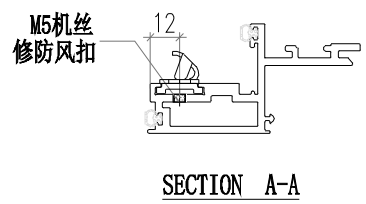
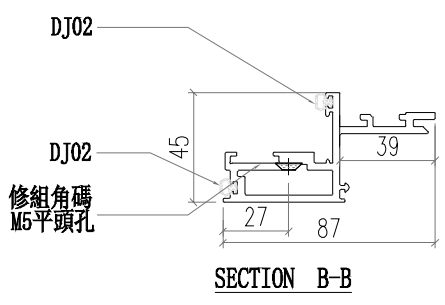
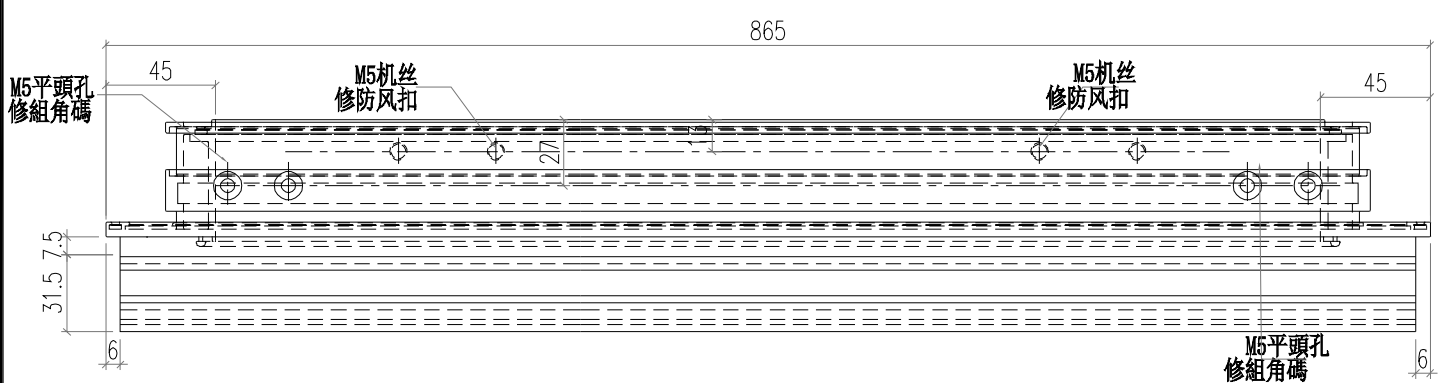
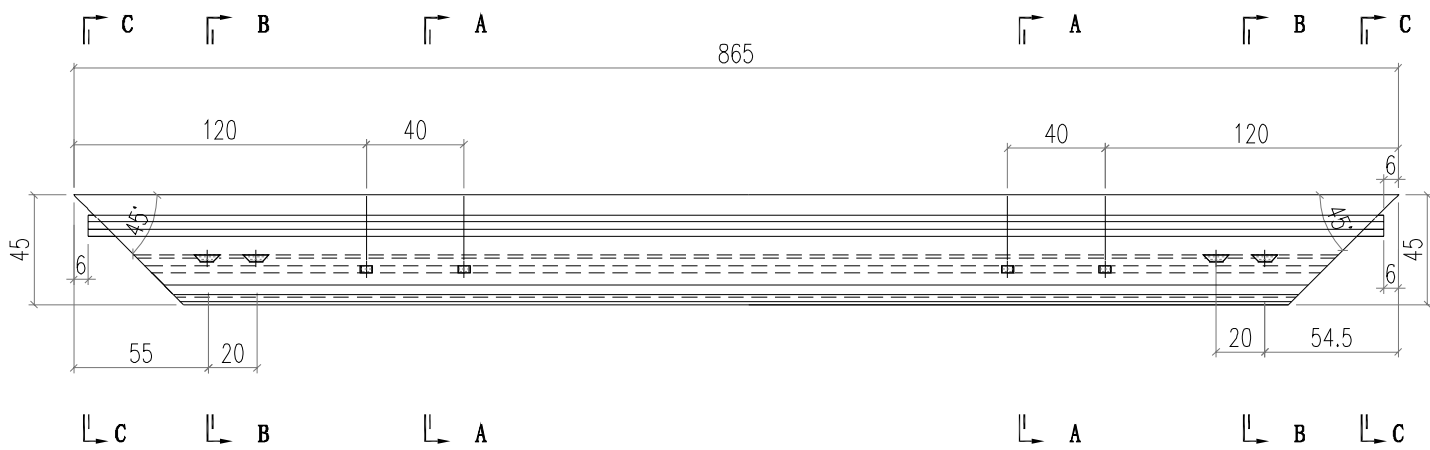

 美特鋁質有限公司 MIDI Aluminium Fabricator Ltd.			工程號 J856 地盘 天榮站	類別 制圖 李傳鵬 復核 練松文 批准 林仁安	物料號 M1 2022-11-25 2022-11-26 2022-11-28	圖號 WS03-P12 數量 - 單件重量 - (KG)
修改日期 採用工廠 材料颜色 -	地盤 ✓ 图纸名称 铝料加工图 材料 WS03					

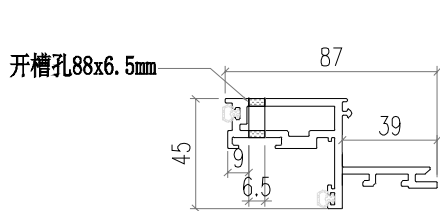

SECTION C-C

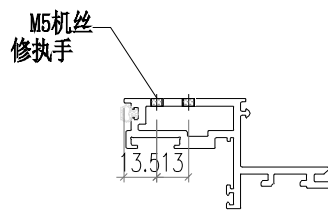

SECTION D-D

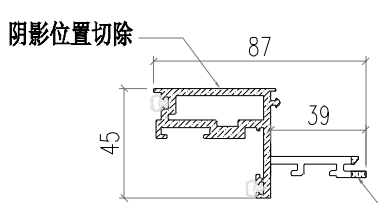
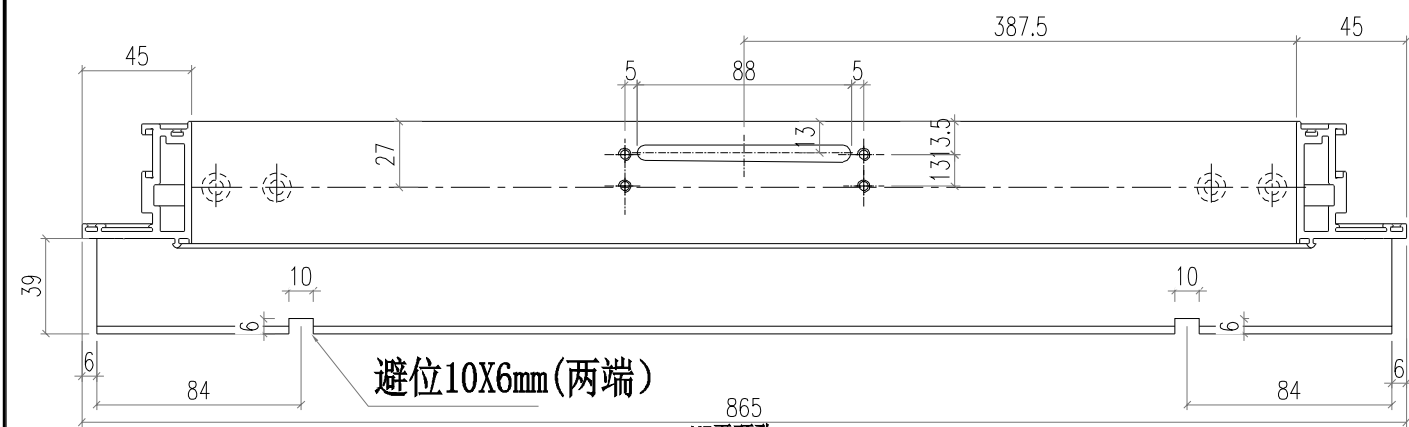
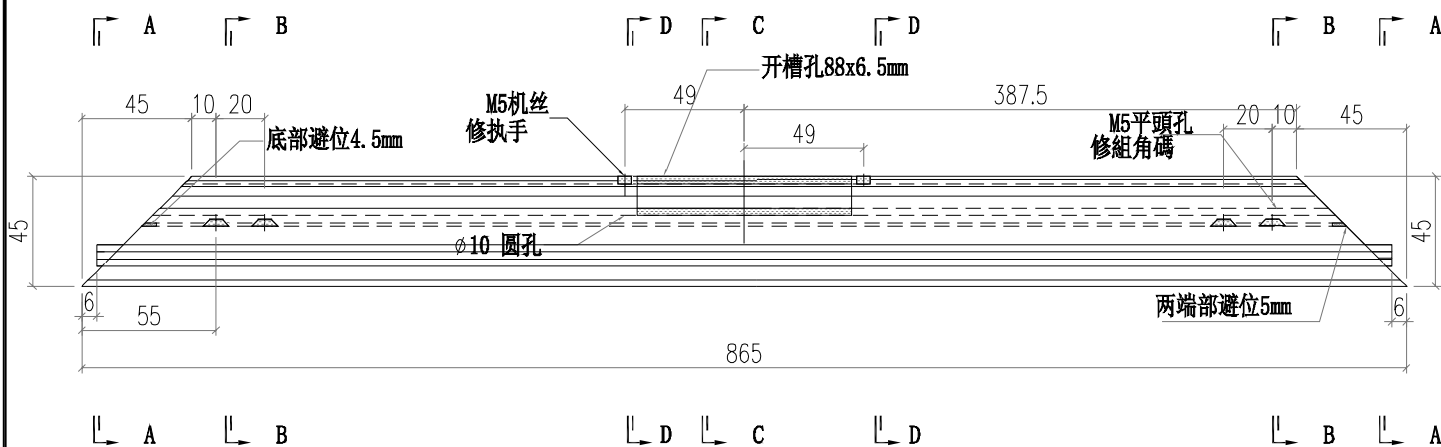

SECTION A-A

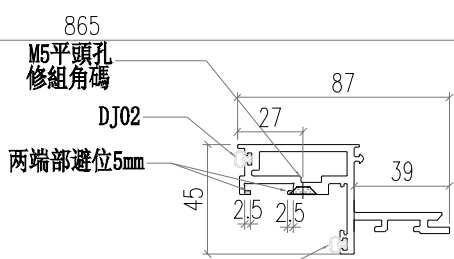

SECTION B-B

避位10X6mm

两端部避位5mm

 美特鋁質有限公司 MIDI Aluminium Fabricator Ltd.			工程號 J856 地盘 天榮站	類別 制圖 李傳鵬 復核 練松文 批准 林仁安	物料號 M1 圖號 WS03-P13 數量 - 單件重量 - (KG)
修改 日期	採用工廠 材料顏色 -	地盘 ✓	图纸名称 铝料加工图 材料 WS03	物料號 M1 圖號 WS03-P13 數量 - 單件重量 - (KG)	

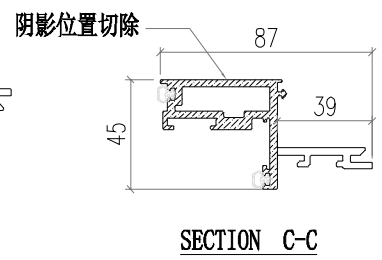
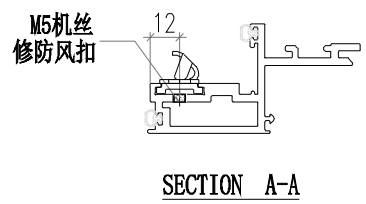
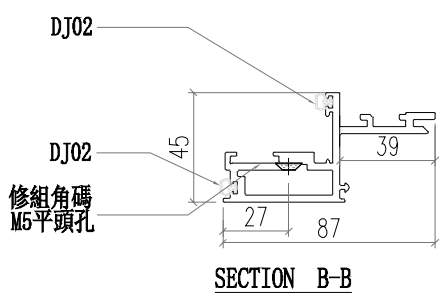
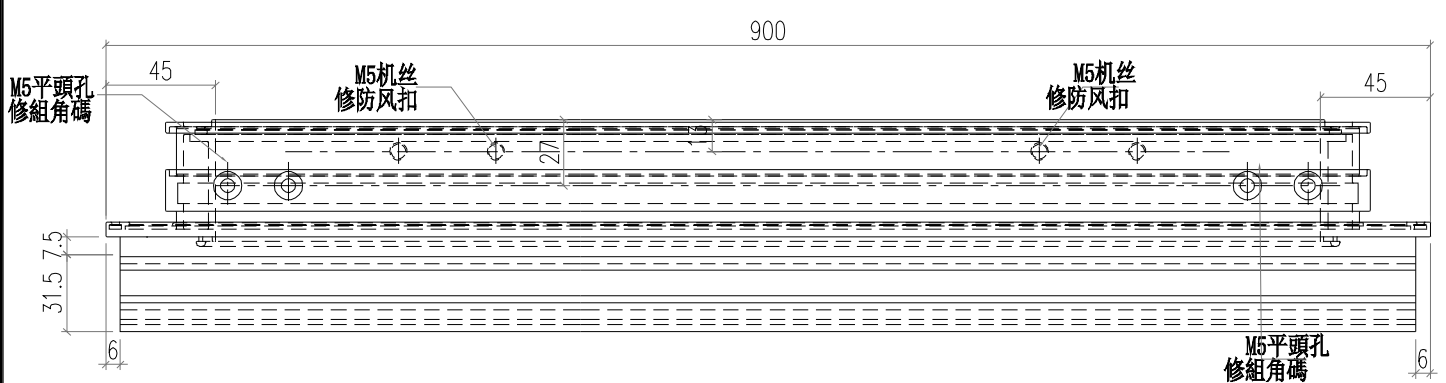
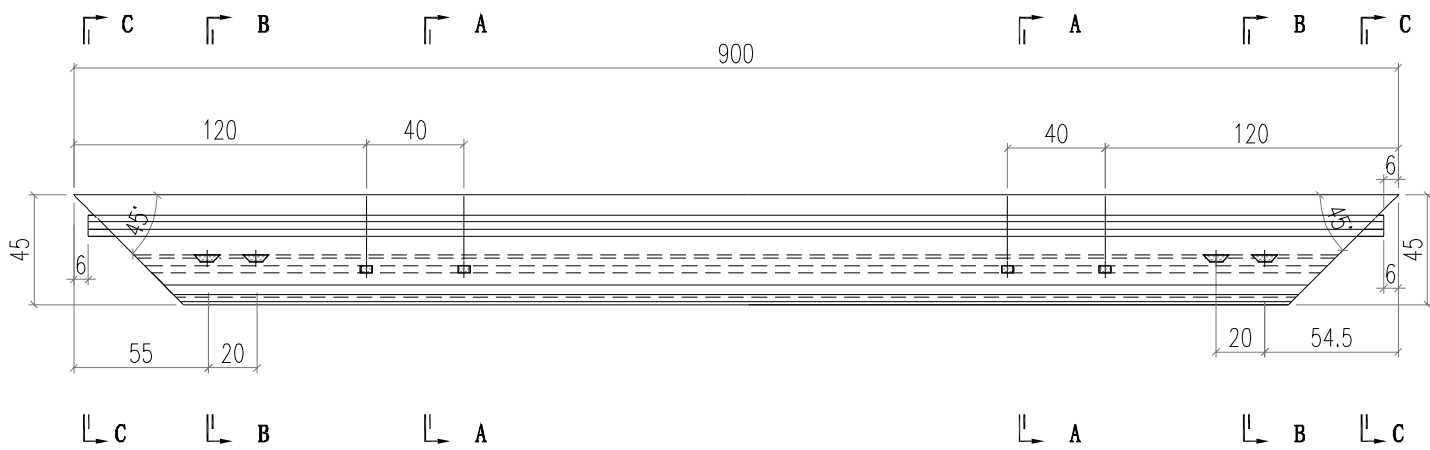

 美特鋁質有限公司 MIDI Aluminium Fabricator Ltd.			工程號 J856 地盘 天榮站	類別 制圖 李傳鵬 復核 練松文 批准 林仁安	物料號 M1 圖號 WS03-P14 數量 - 單件重量 - (KG)
修改日期 採用工廠 材料颜色 -	地盤 ✓ 图纸名称 铝料加工图 材料 WS03				

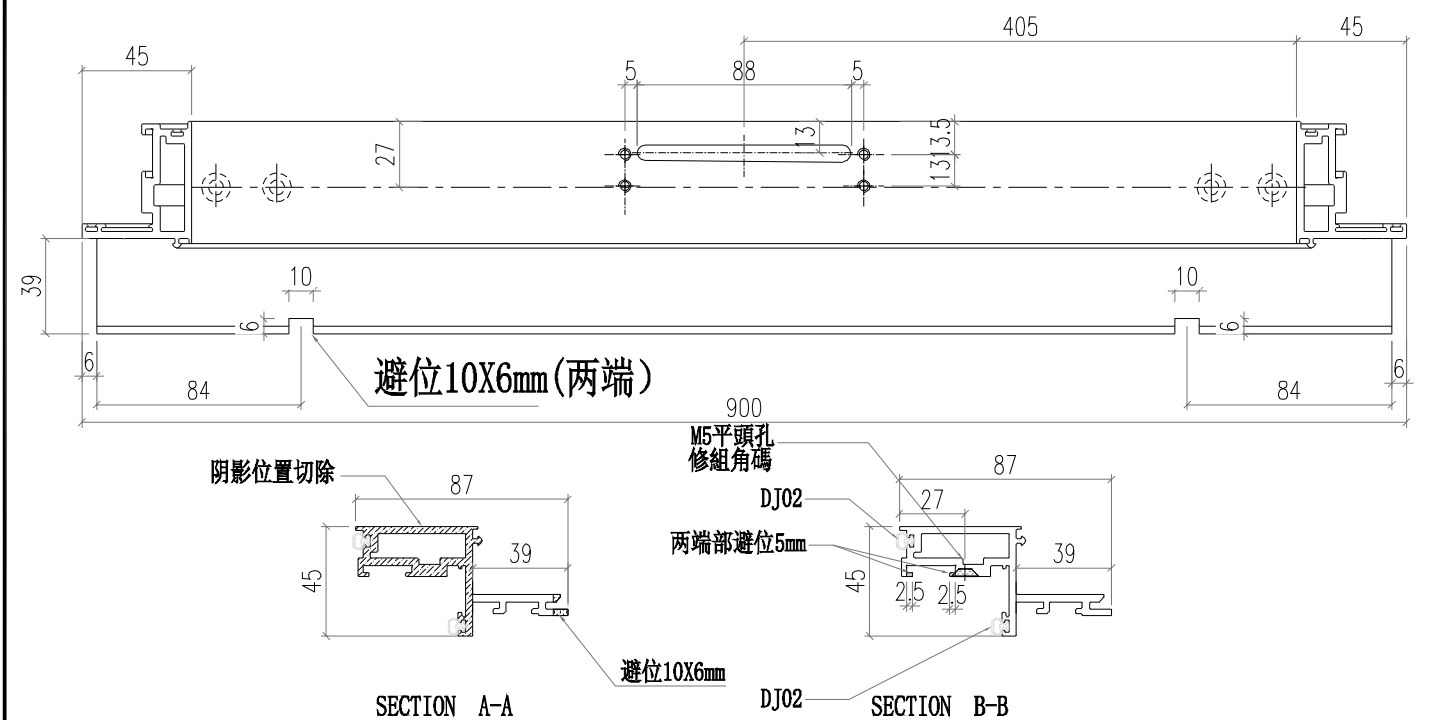
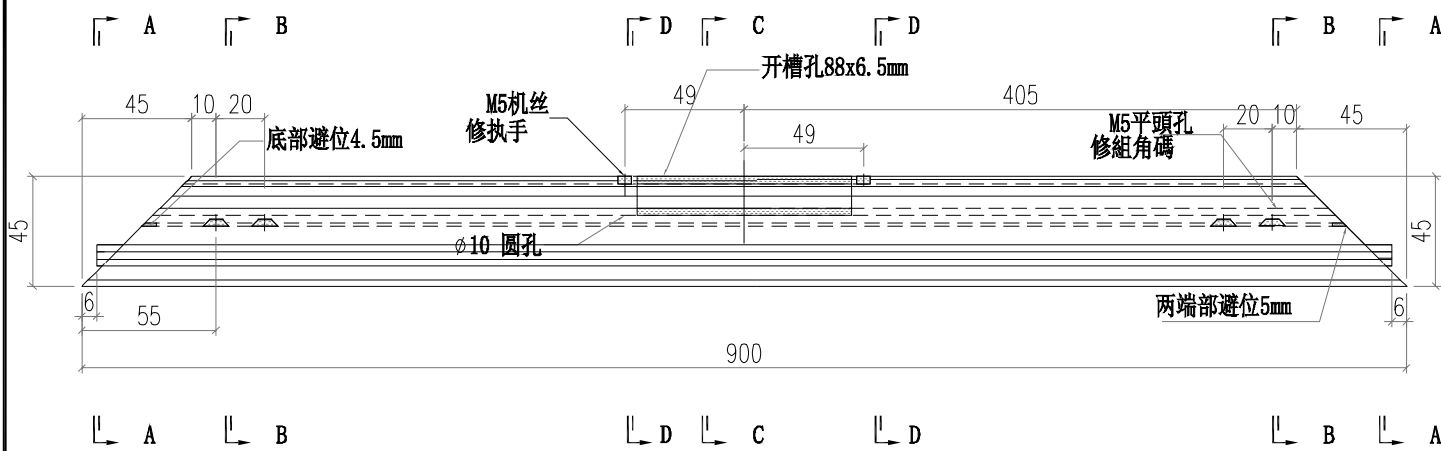
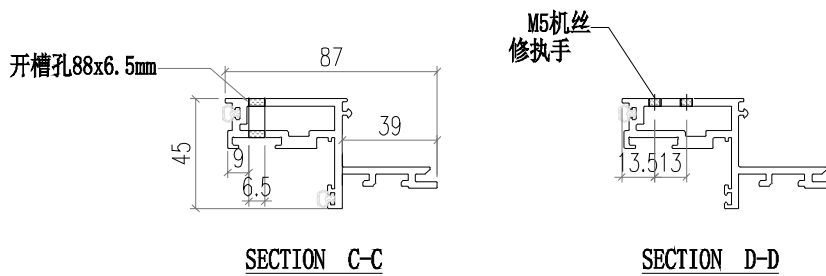

 美特鋁質有限公司 MIDI Aluminium Fabricator Ltd.			工程號 J856 地盘 天榮站	類別 制圖 李傳鵬 復核 練松文 批准 林仁安	物料號 M1 圖號 WS03-P15 數量 - 單件重量 - (KG)
修改日期 採用工廠 材料颜色 -	地盤 ✓	图纸名称 铝料加工图 材料 WS03			

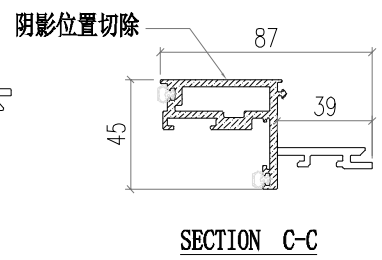
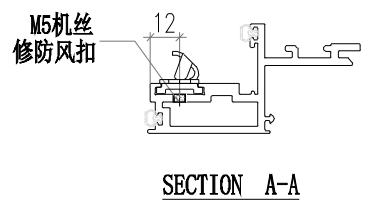
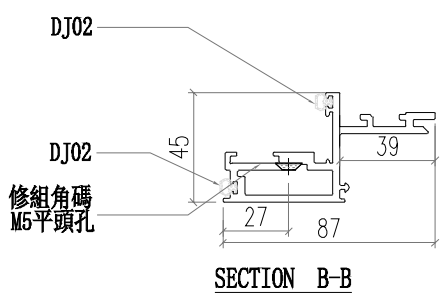
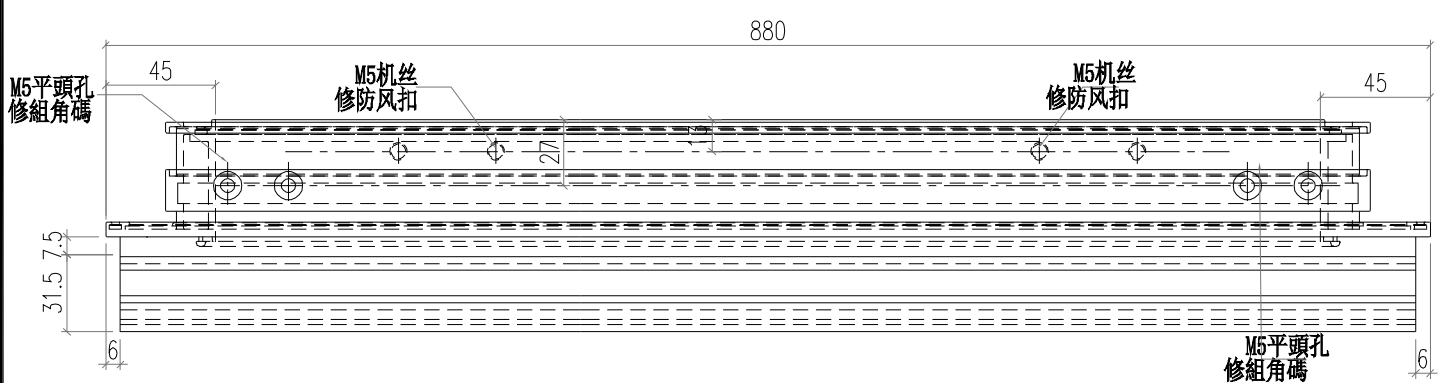
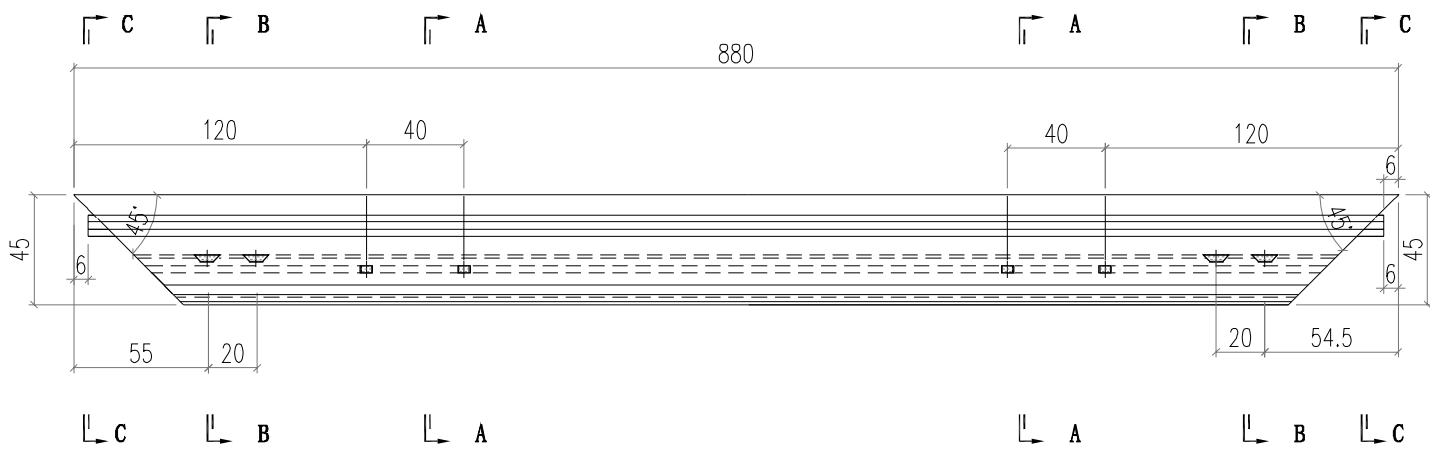

 美特鋁質有限公司 MIDI Aluminium Fabricator Ltd.			工程號 J856 地盘 天榮站	類別 制圖 李傳鵬 復核 練松文 批准 林仁安	物料號 M1 圖號 WS03-P16 數量 - 單件重量 - (KG)
修改日期 採用工廠 材料颜色 -	地盤 ✓ 图纸名称 铝料加工图 材料 WS03				

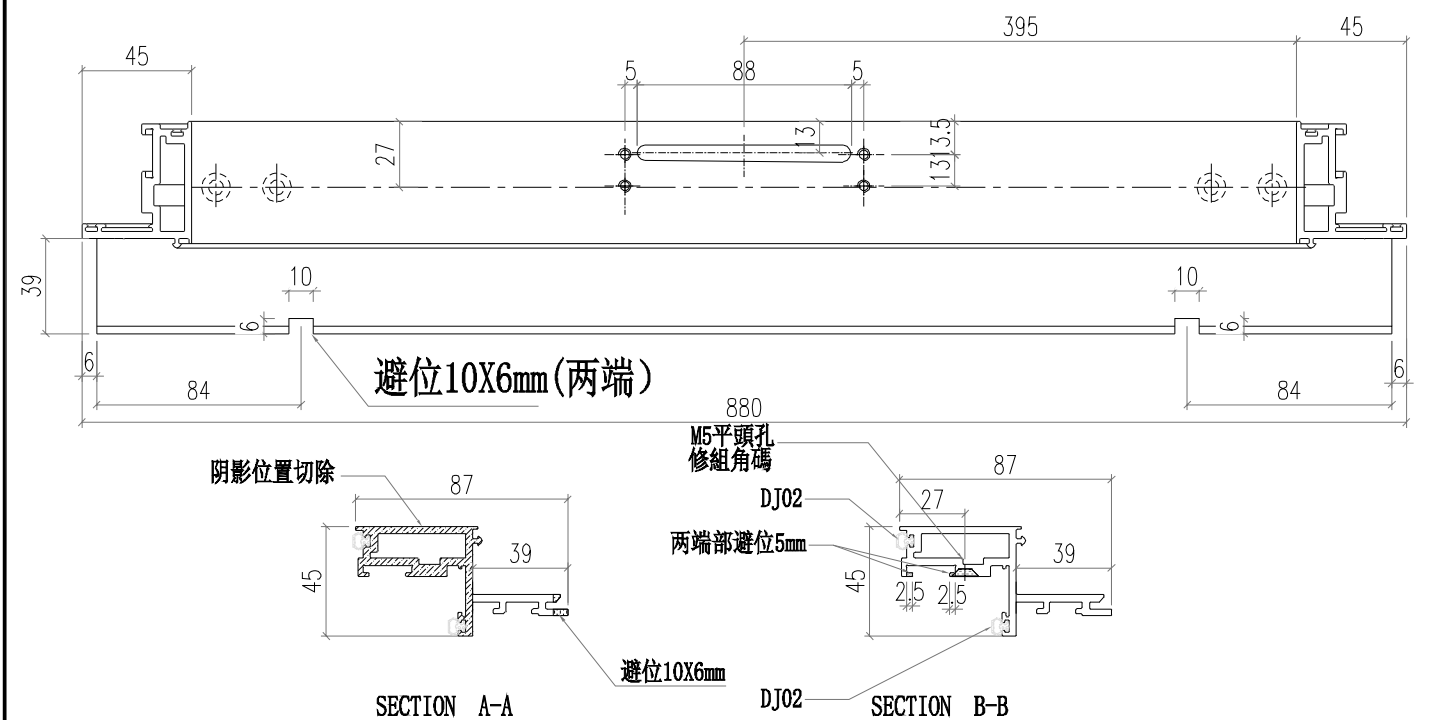
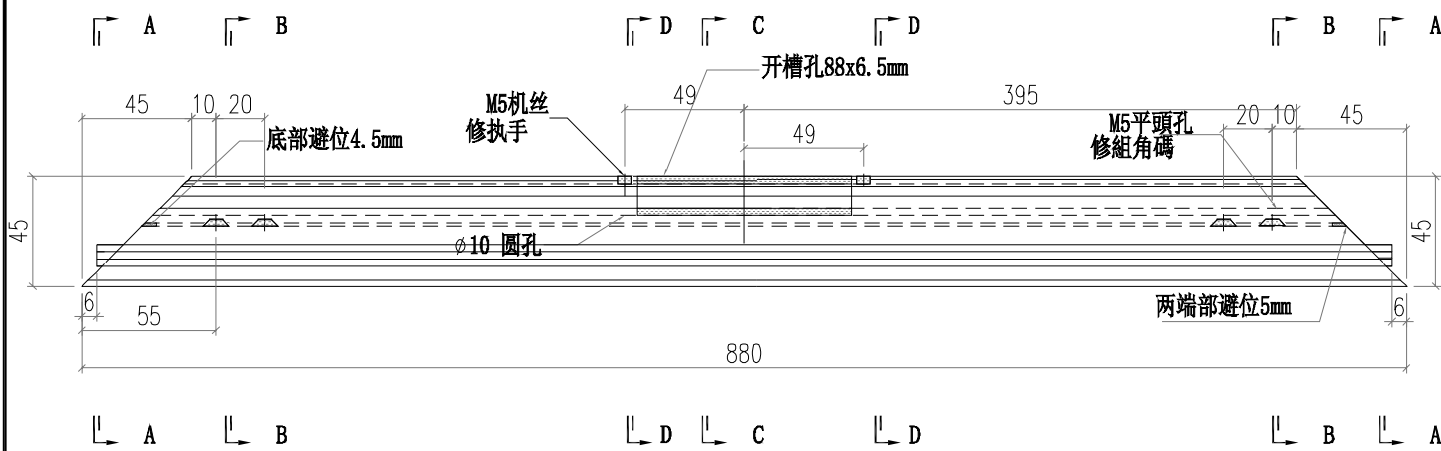
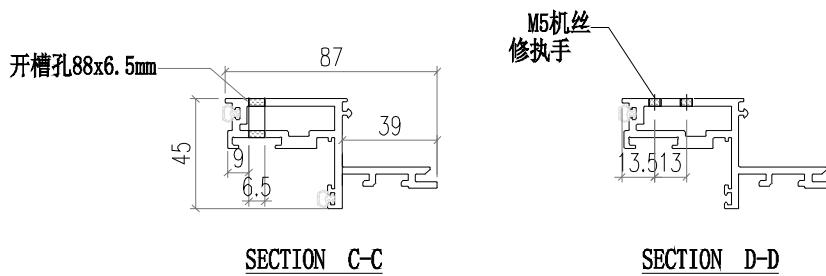

 美特鋁質有限公司 MIDI Aluminium Fabricator Ltd.			工程號 J856 地盘 天榮站	類別 制圖 李传鹏 復核 練松文 批准 林仁安	物料號 M1 圖號 X86370-P01 數量 - 單件重量 - (KG)
修改 日期	採用工廠 材料顏色 AL2:ECK3X10063S-XF1	地盘 ✓	图纸名称 铝料加工图 材料 X86370	物料號 M1 圖號 X86370-P01 數量 - 單件重量 - (KG)	

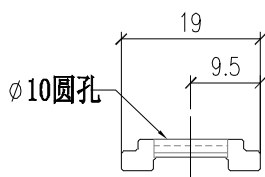
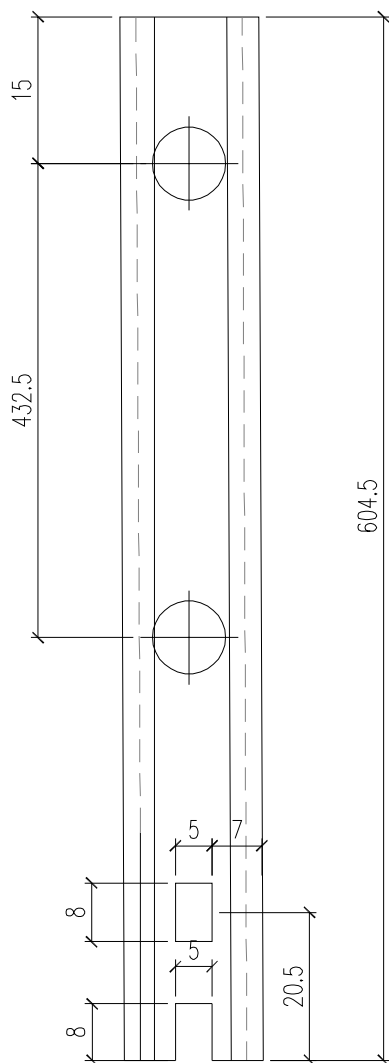

 美特鋁質有限公司 MIDI Aluminium Fabricator Ltd.				工程號 J856 地盘 天榮站	類別 制圖 李传鹏 復核 練松文 批准 林仁安	物料號 M1 圖號 X86370-P03 數量 - 單件重量 - (KG)
修改 日期	採用工廠 材料颜色 AL2:ECK3X10063S-XF1	地盘 ✓ 图纸名称 铝料加工图 材料 X86370	圖號 X86370-P03 數量 - 單件重量 - (KG)			

TOP

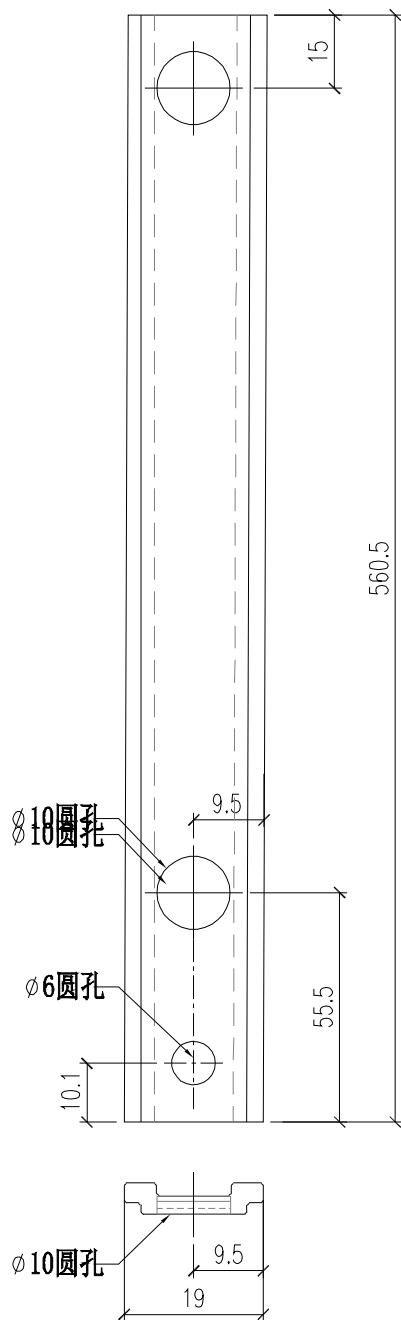

 美特鋁質有限公司 MIDI Aluminium Fabricator Ltd.			工程號	J856	類別		物料號	M1			
			地盘	天榮站	制圖	李传鹏	2022-11-25	圖號	X86370-P02		
修改		採用工廠	地盘	✓	图纸名称	铝料加工图	復核	練松文	2022-11-26	數量	-
日期		材料颜色	AL2:ECK3X10063S-XF1		材料	X86370	批准	林仁安	2022-11-28	單件重量	- (KG)

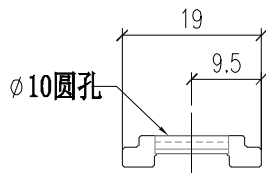
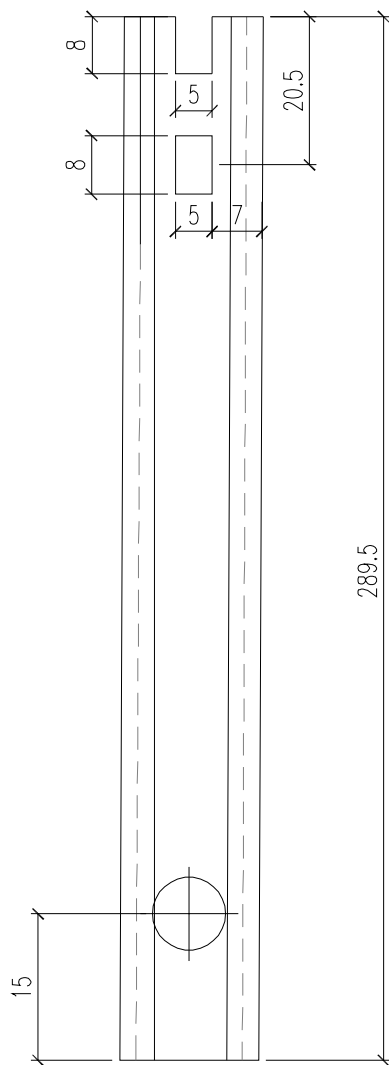

 美特鋁質有限公司 MIDI Aluminium Fabricator Ltd.			工程號	J856	類別		物料號	M1	
			地盘	天榮站	制圖	李传鹏	2022-11-25	圖號	X86370-P04
修改		採用工廠	地盘	✓	图纸名称	铝料加工图	復核	練松文	2022-11-26
日期		材料颜色	AL2:ECK3X10063S-XF1		材料	X86370	批准	林仁安	2022-11-28
							數量	-	
							單件重量	-	(KG)

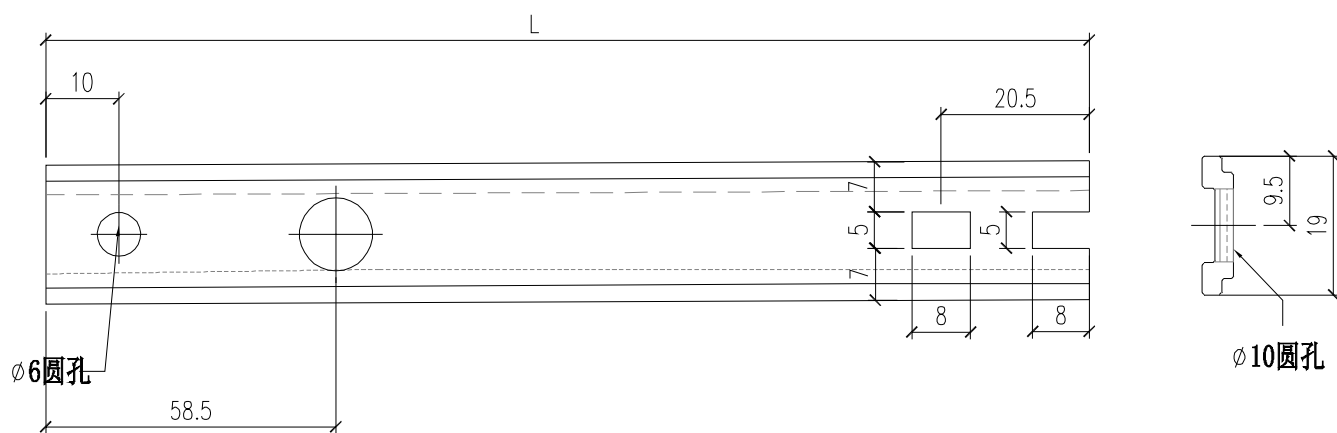

部件编号	L 分格尺寸		
X86370-P04-01	233	650	
X86370-P04-02	209.5	720	转角位
X86370-P04-03	259.5	820	转角位
X86370-P04-04	159.5	620	转角位
X86370-P04-05	350.5	855	
X86370-P04-06	368	920	
X86370-P04-07	358	900	

 美特鋁質有限公司 MIDI Aluminium Fabricator Ltd.				工程號 J856	類別	物料號 M1		
				地盘 天榮站	制圖 李传鹏	2022-11-25	圖號 X86370-K1	
修改		採用工廠	地盘 ✓	图纸名称 铝料加工图	復核 練松文	2022-11-26	數量 -	
日期		材料颜色 AL2:ECK3X10063S-XF1		材料 X86370	批准 林仁安	2022-11-28	單件重量 -	(KG)

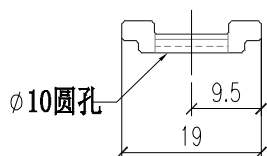
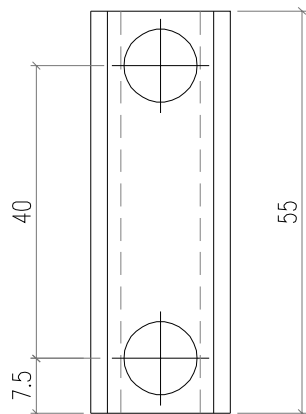

 美特鋁質有限公司 MIDI Aluminium Fabricator Ltd.				工程號	J856	類別		物料號	M1
修改		採用工廠	地盤	✓	地盤	天榮站	制圖	李傳鵬	2022-11-25
日期		材料顏色	-	圖紙名稱	铝料加工圖	復核	練松文	2022-11-26	圖號
				材料	X86412	批准	林仁安	2022-11-28	數量
									單件重量
									- (KG)

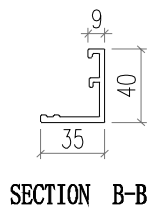
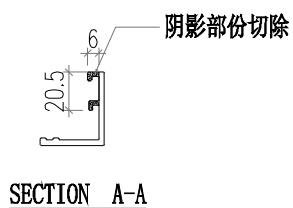
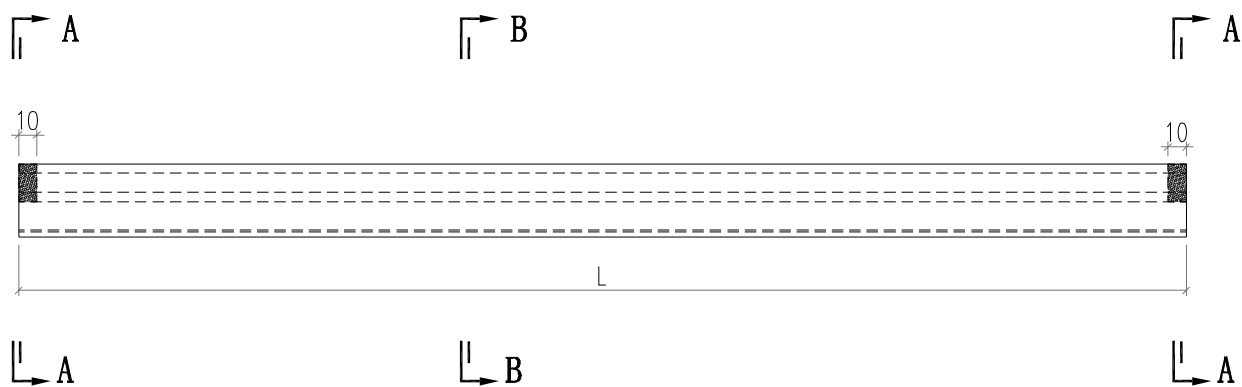

部件编号	L	分格尺寸
X86412-E01-1	630	650
X86412-E01-2	865	885
X86412-E01-3	900	920
X86412-E01-4	880	900

 美特鋁質有限公司 MIDI Aluminium Fabricator Ltd.				工程號	J856	類別		物料號	M1	
修改		採用工廠		地盤	天榮站	制圖	李傳鵬	2022-11-26	圖號	X86412-E02
日期		材料顏色	-UCT542919XL-3	图纸名称	铝料加工图	復核	練松文	2022-11-27	數量	-
				材料	X86412	批准	林仁安	2022-11-28	單件重量	- (KG)

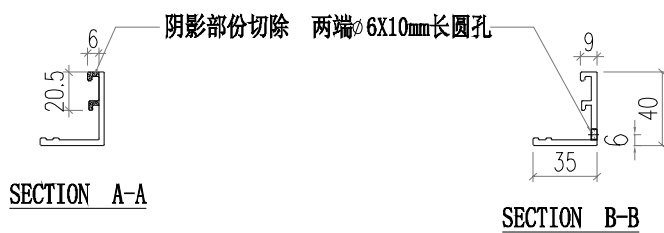

部件编号	L	分格尺寸
X86412-E02-1	630	650
X86412-E02-2	865	885
X86412-E02-3	900	920
X86412-E02-4	880	900

 美特鋁質有限公司 MIDI Aluminium Fabricator Ltd.				工程號	J856	類別		物料號	M1		
				地盘	天榮站	制圖	李傳鵬	2022-11-25	圖號	AC02-E01	
修改		採用工廠	地盤	✓	图纸名称	铝料加工图	復核	練松文	2022-11-26	數量	-
日期		材料颜色	-		材料	AC02	批准	林仁安	2022-11-28	單件重量	- (KG)

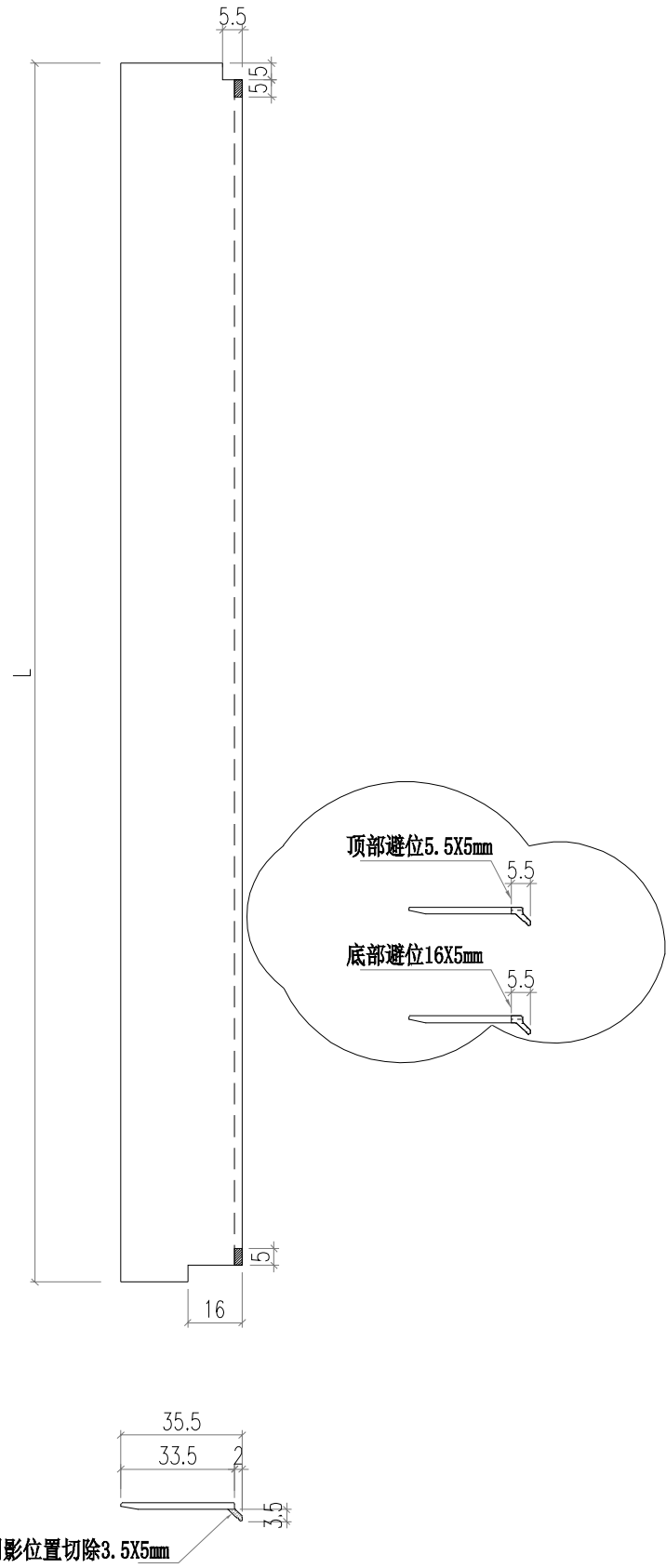

部件编号	L	分格尺寸
AC02-E01-1	1137	1165

 美特鋁質有限公司 MIDI Aluminium Fabricator Ltd.				工程號	J856	類別		物料號	M1	
修改 日期				地盤	天榮站	制圖	李傳鵬	2022-11-25	圖號	AC02-E01R
採用工廠 材料顏色				地盤	✓	圖紙名稱	鋁料加工圖	復核	練松文	2022-11-26
				材料	AC02	批准	林仁安	2022-11-28	數量	-
								單件重量	-	(KG)

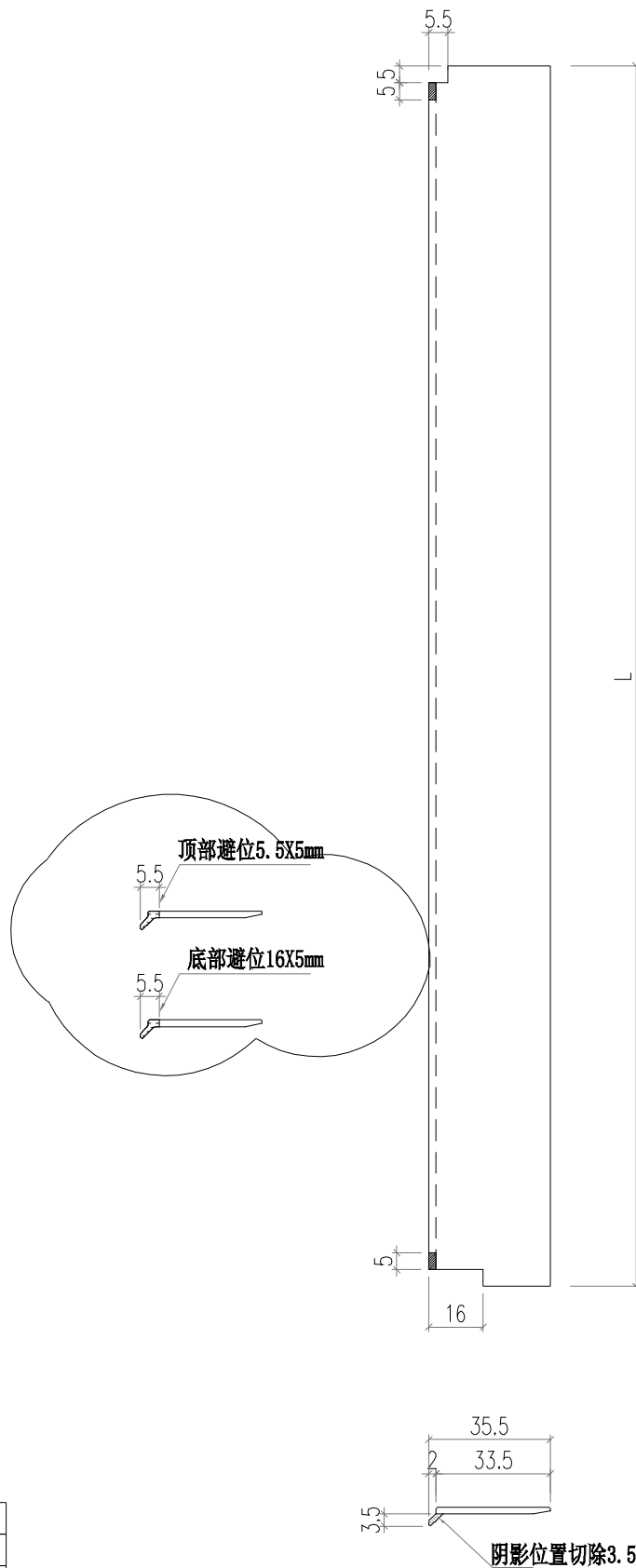

部件编号	L 分格尺寸	
AC02-E01R-1	1137	1165

 美特鋁質有限公司 MIDI Aluminium Fabricator Ltd.			工程號 J856 地盘 天榮站	類別 制圖 李傳鵬 復核 練松文 批准 林仁安	物料號 M1 2022-11-25 2022-11-26 2022-11-28	圖號 JS01-Q01 數量 - 單件重量 - (KG)	
修改 日期	採用工廠 材料颜色 -	地盤 <input checked="" type="checkbox"/>	图纸名称 铝料加工图 材料 60*60*5铝角				

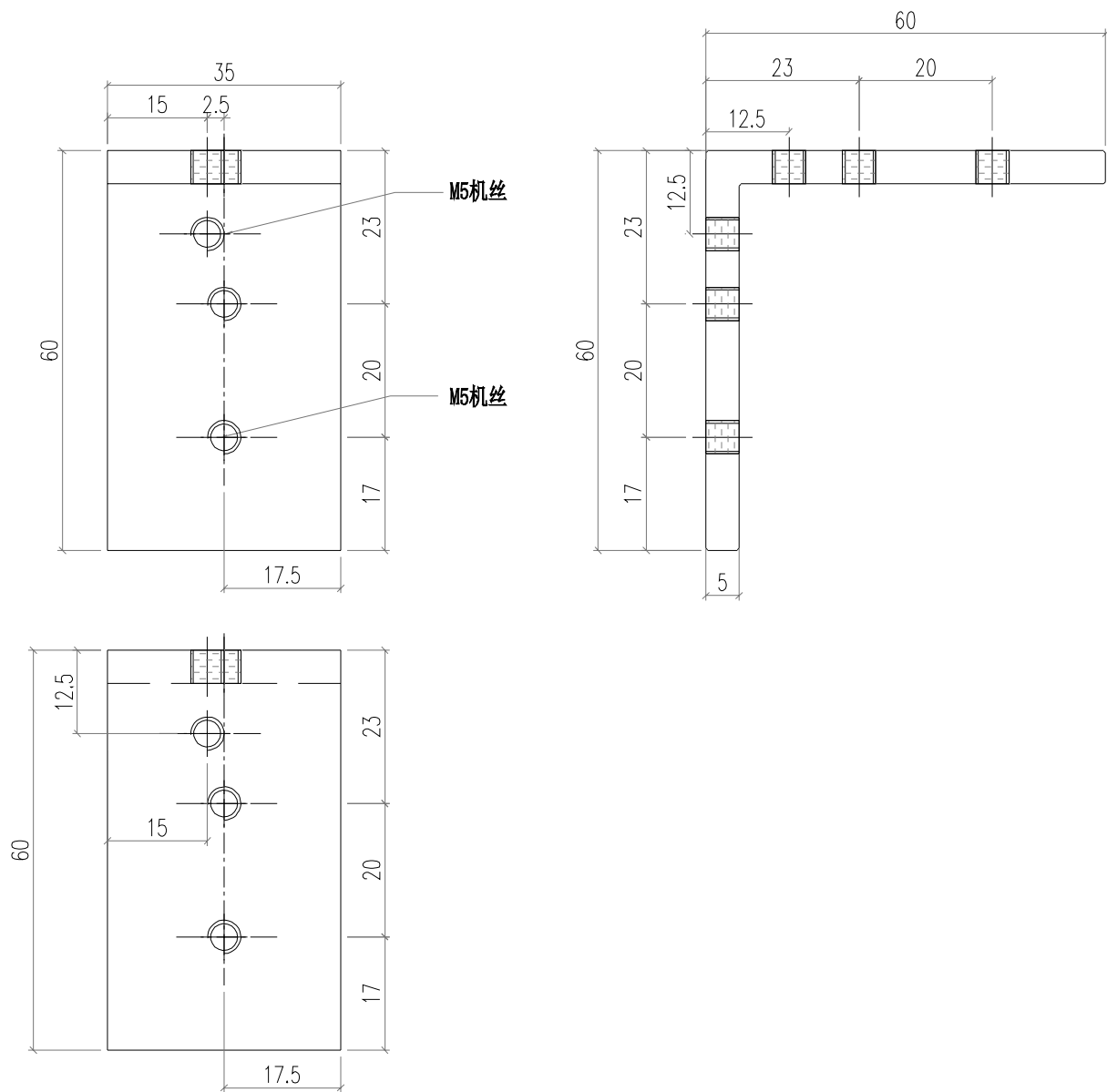

钻孔攻牙前需要试做一下抢位是否够
 M01 第一批做340

 美特鋁質有限公司 MIDI Aluminium Fabricator Ltd.				工程號 J856 地盘 天榮站	類別 制圖 李傳鵬 復核 練松文 批准 林仁安	物料號 M1 2022-11-25 2022-11-26 2022-11-28	圖號 JS01-Q02 數量 - 單件重量 - (KG)
修改 日期	採用工廠 材料颜色 -	地盤 <input checked="" type="checkbox"/>	图纸名称 铝料加工图 材料 60*60*5铝角				

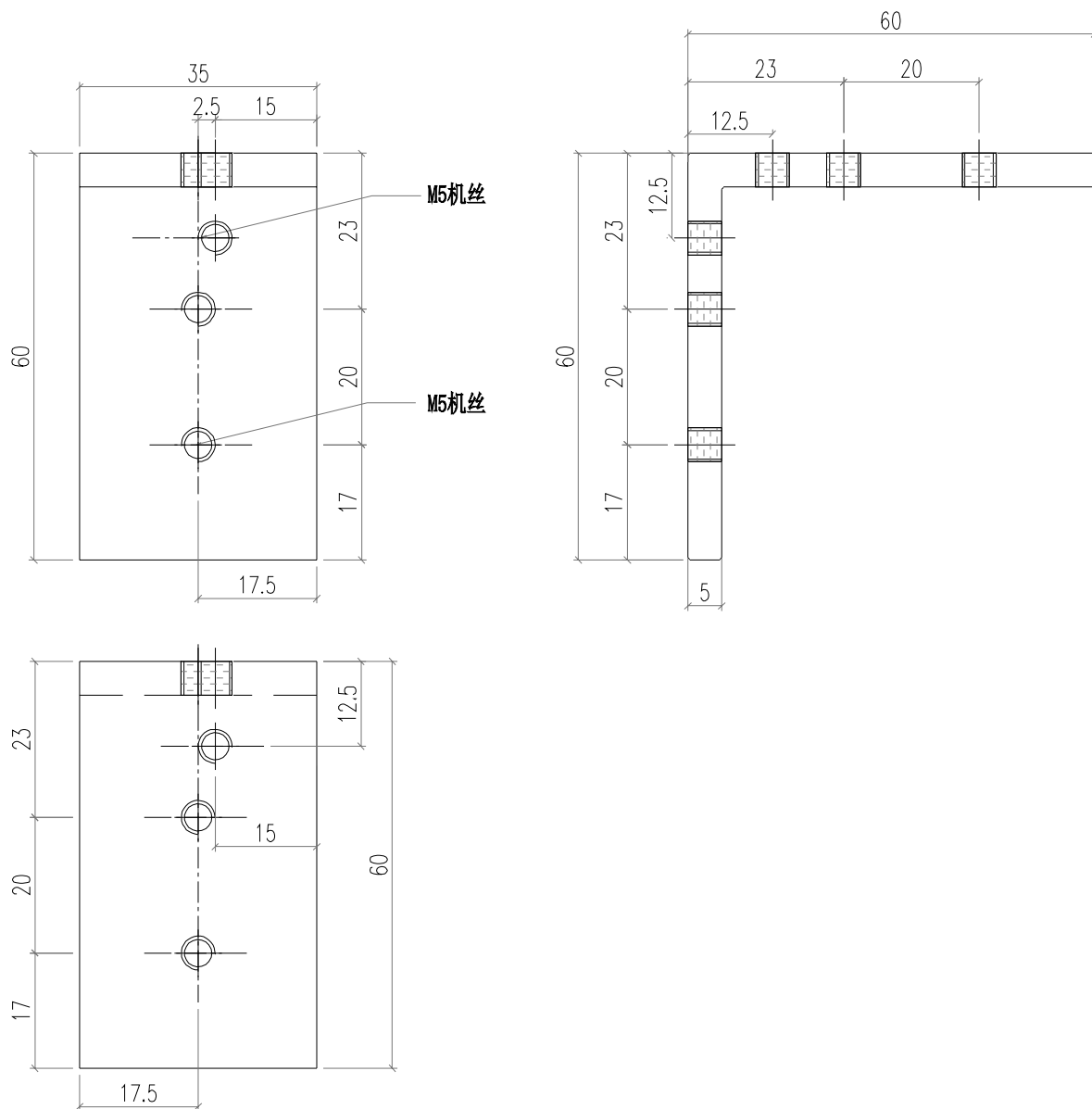

钻孔攻牙前需要试做一下抢位是否够
 M01 第一批做340