



工程指示 / 要求簡箋 ENGINEER INSTRUCTIONS(E.I.)

工程指示編號:	EI- 6253	修改版本:	-
	HK- 1182		
工程編號:	J 856	工程名稱:	天榮站
收件人:	生統 / Maggie	發件人:	Jingo
工程項目:	46/F SIMPLEX 趟門鋁料模圖	日期:	25/05/2023

<input checked="" type="checkbox"/> 原合約工程包	<input type="checkbox"/> 原合約工程加 / 減脹 QT-	<input type="checkbox"/> 新工程報價 QT-
--	--	------------------------------------

信件批核號碼/圖紙參考編號:	批核模具圖紙編號:
客戶指示附件:	管理內部批簽署:

<input type="checkbox"/> 初步鋁料 B.M.	<input type="checkbox"/> 加工拆圖, 然後生產	<input type="checkbox"/> 尺寸表
<input type="checkbox"/> 正式鋁料 B.M.	<input type="checkbox"/> 技術上資料/指示	<input type="checkbox"/> 報價
<input type="checkbox"/> 配件 B.M.	<input type="checkbox"/> 樣辦或貨品說明書	<input type="checkbox"/> 分判合約
<input type="checkbox"/> 其他:		

內容: 請安排 46/F SIMPLEX 趟門鋁料新模圖22個 X86472, X86473, X86474, X86475, X86476, X86477, X86478, X86479, X86480, X86481, X86482, X86483, X86484, X86485, X86486, X86487, X86488, X86489, X86490, X86491, X86492, X86493 預算完成模圖: 2/6/2023 完成開模及試模: 23/6/2023 參考 Siegenia.
完成上列要求日期:

國內

<input type="checkbox"/> 生產技術總監	<input type="checkbox"/> 連附件	<input checked="" type="checkbox"/> 技術部	<input checked="" type="checkbox"/> 連附件	<input type="checkbox"/> 生產部	<input type="checkbox"/> 連附件
<input type="checkbox"/> 採購部	<input type="checkbox"/> 連附件	<input checked="" type="checkbox"/> 生產統籌部	<input checked="" type="checkbox"/> 連附件	<input type="checkbox"/> 報關組	<input type="checkbox"/> 連附件
<input checked="" type="checkbox"/> 質檢部	<input checked="" type="checkbox"/> 連附件	<input type="checkbox"/> 會計部	<input type="checkbox"/> 連附件	<input type="checkbox"/> 機械設計部	<input type="checkbox"/> 連附件
<input type="checkbox"/> 香港辦	<input type="checkbox"/> 連附件	<input type="checkbox"/> 其他:			

香港

<input type="checkbox"/> 行政部	<input type="checkbox"/> 連附件	<input type="checkbox"/> 會計部	<input type="checkbox"/> 連附件	<input type="checkbox"/> 統籌部	<input type="checkbox"/> 連附件	<input type="checkbox"/> 工程部	<input type="checkbox"/> 連附件
<input checked="" type="checkbox"/> 採購部	<input checked="" type="checkbox"/> 連附件	<input type="checkbox"/> QS部	<input type="checkbox"/> 連附件	<input type="checkbox"/> 地盤管理	<input type="checkbox"/> 連附件	<input type="checkbox"/> 維修部	<input type="checkbox"/> 連附件

*發件人簽署: Jingo	*組別成員批核簽署:
傳遞編號:	項目經理簽署:

CUSTOMER	HONGKONG CO.	CUSTOMER APPROVAL	CUST PART NO.	X86472
			SECTION NO.	

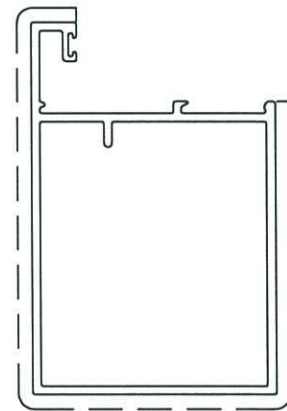
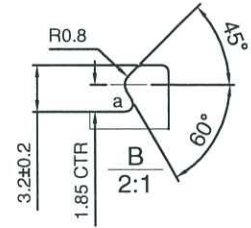
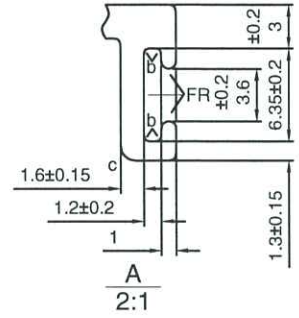
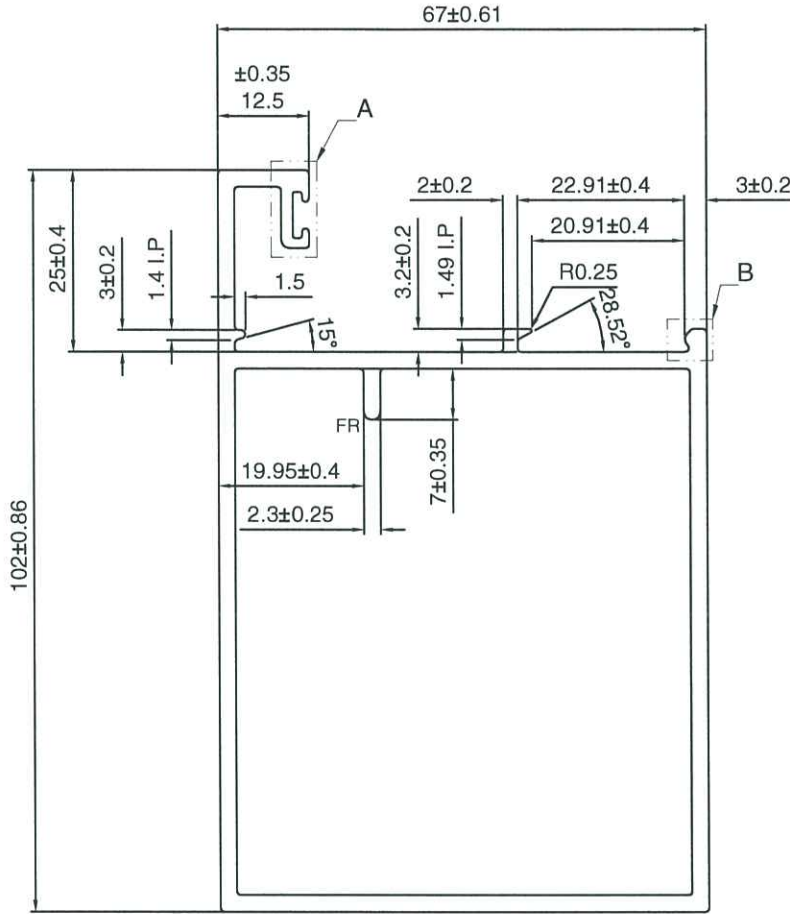

美特鋁質有限公司
承認圖面
日期 25.5.2023

a=R0.5
b=R0.3
c=R1

备注：没有配合型号！

V.F

SCALE 1:2

AREA (SQ MM)	776.67	UNSPECIFIED THICKNESS	2.3±0.25	PERIMETER (MM)	398.93	STANDARD	BS EN755	SCALE	1:1
MASS (KG/M)	2.105	UNSPECIFIED CORNERS	R 0.4	SURFACE AREA	261.64	ALLOY	6063-T6	VERSION	A
COMPANY ISSUE	-	DRAWN	黃瓊玉	DATE	2023-05-19	APPELLATION	-	PAGE OF	
		STANDARDIZATION		DATE					
		TO SIGN		DATE					
		AUDITING		DATE					
MARKER	MODIFY	FILE NO	SIGNATURE	DATE	APPROV				

CUSTOMER	HONGKONG CO.	CUSTOMER APPROVAL	CUST PART NO.	X86474
			SECTION NO.	

美特鋁質有限公司
承認圖面
日期 25.5.2023

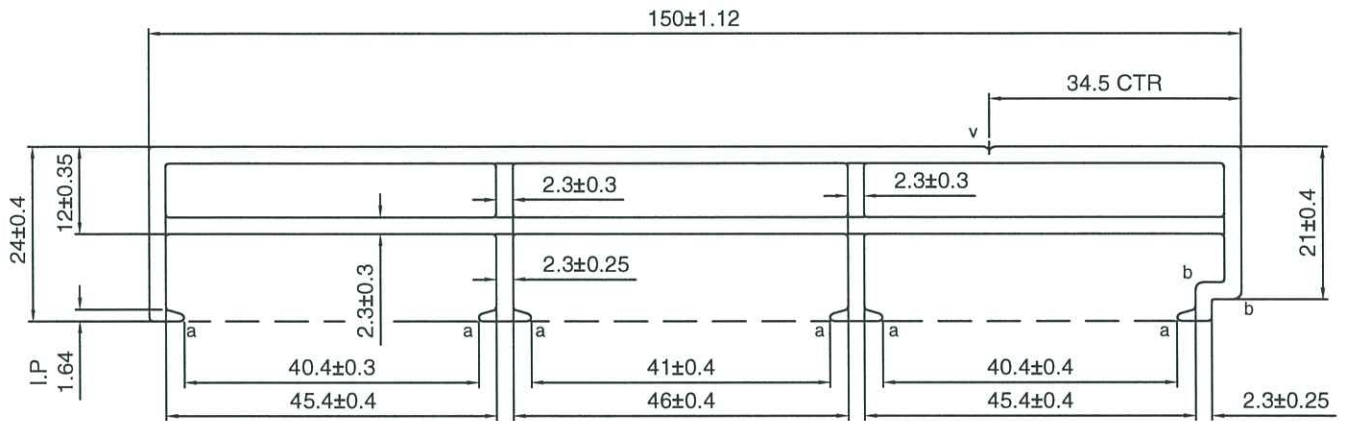

v=0.5X90°

a=R0.5

b=R1

■处有轻微的结构性线纹

备注：没有配合型号！

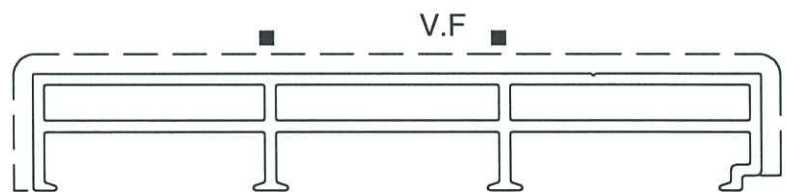

SCALE 1:1.5

AREA (SQ MM)	895.97	UNSPECIFIED THICKNESS	2.3±0.25	PERIMETER (MM)	446.19	STANDARD	BS EN755	SCALE	1:1
MASS (KG/M)	2.428	UNSPECIFIED CORNERS	R 0.4	SURFACE AREA	195.84	ALLOY	6063-T6	VERSION	A
COMPANY ISSUE	-	DRAWN	黃瓊玉	DATE	2023-05-19	APPELLATION	-	PAGE OF	
		STANDARDIZATION		DATE		 美特鋁質有限公司 MIDI Aluminium Fabricator Ltd.			
		TO SIGN		DATE					
		AUDITING		DATE					
MARKER	MODIFY	FILE NO	SIGNATURE	DATE	APPROV				

CUSTOMER	HONGKONG CO.	CUSTOMER APPROVAL	CUST PART NO.	X86475
			SECTION NO.	

美特鋁質有限公司	
承認圖面	
日期	25.5.2023

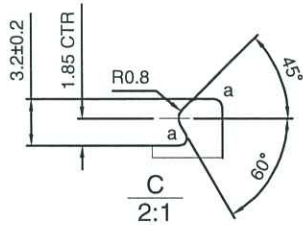
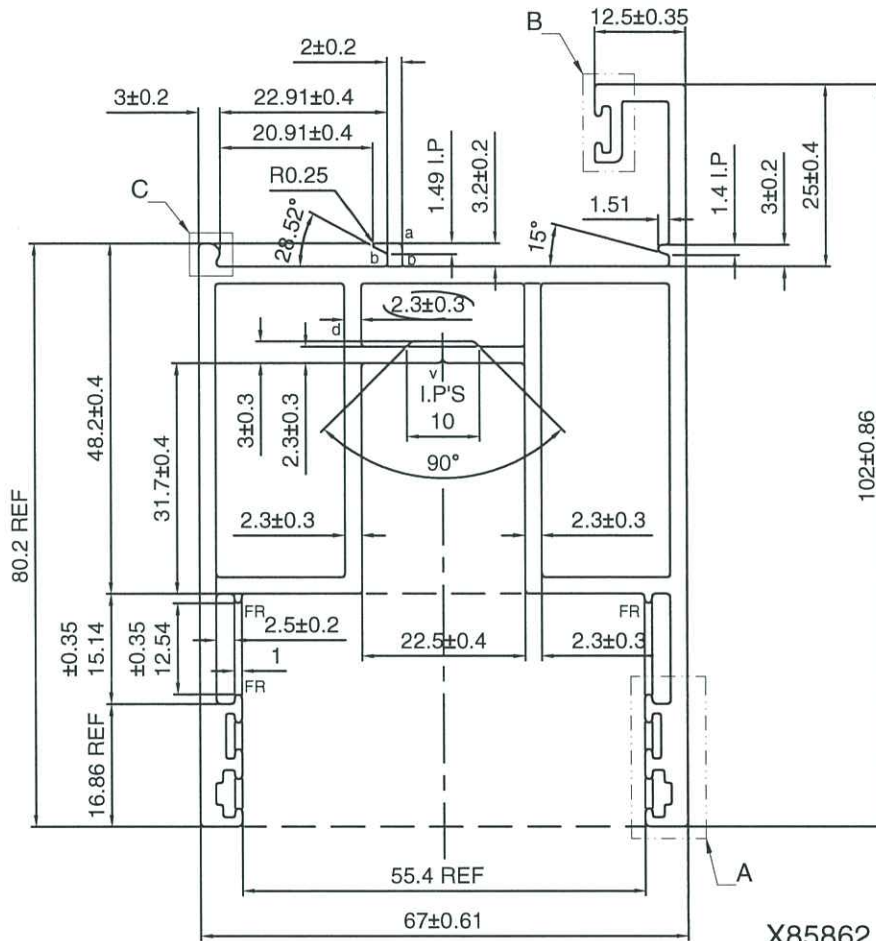

v=0.5X90°
a=R0.5 b=R0.3
c=R1 d=R2

*配合尺寸以实物配合效果为准!

AREA (SQ MM)	1018.95	UNSPECIFIED THICKNESS	2.3±0.25	PERIMETER (MM)	583.72	STANDARD	BS EN755	SCALE	1:1
MASS (KG/M)	2.761	UNSPECIFIED CORNERS	R 0.4	SURFACE AREA	206.87	ALLOY	6063-T6	VERSION	A
COMPANY ISSUE	-	DRAWN	黃瓊玉	DATE	2023-05-19	APELLATION	-	PAGE OF	
		STANDARDIZATION		DATE		 美特鋁質有限公司 MIDI Aluminium Fabricator Ltd.			
		TO SIGN		DATE					
		AUDITING		DATE					
MARKER	MODIFY	FILE NO	SIGNATURE	DATE	APPROV				

CUSTOMER	HONGKONG CO.	CUSTOMER APPROVAL	CUST PART NO.	X86476
			SECTION NO.	

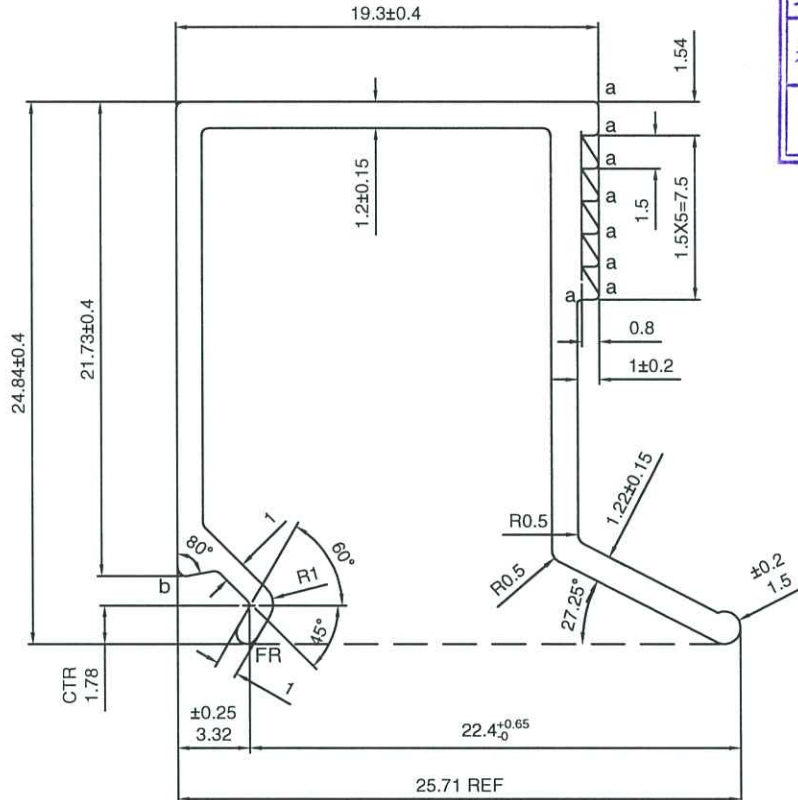

美特鋁質有限公司

承認圖面	<i>[Signature]</i>
日期	25.5.2023

a=R0.2
b=R0.4

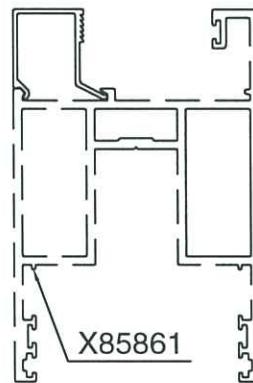

SCALE 1:2

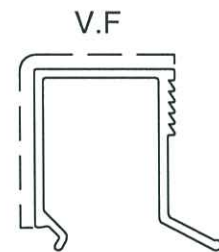

SCALE 1:1

*配合尺寸以实物配合效果为准!

AREA (SQ MM)	93.21	UNSPECIFIED THICKNESS	1.2±0.15	PERIMETER (MM)	151.78	STANDARD	BS EN755	SCALE	3:1
MASS (KG/M)	0.253	UNSPECIFIED CORNERS	R 0.3	SURFACE AREA	41.31	ALLOY	6063-T5	VERSION	A
COMPANY ISSUE	-	DRAWN	黃瓊玉	DATE	2023-05-19	APPELLATION	-	PAGE OF	
		STANDARDIZATION		DATE		 美特鋁質有限公司 MIDI Aluminium Fabricator Ltd.			
		TO SIGN		DATE					
		AUDITING		DATE					
MARKER	MODIFY	FILE NO	SIGNATURE	DATE	APPROV				

CUSTOMER	HONGKONG CO.	CUSTOMER APPROVAL	CUST PART NO.	x 86478
			SECTION NO.	

美特鋁質有限公司
承認圖面
日期 25.5.2023

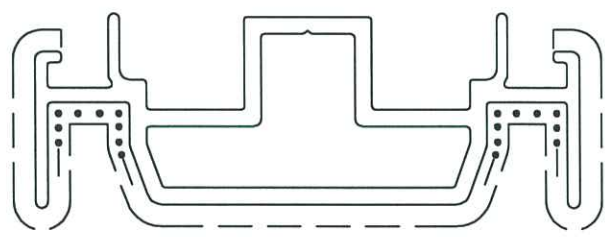
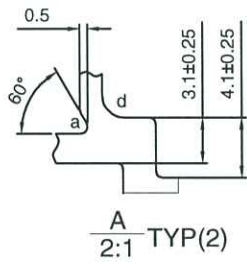
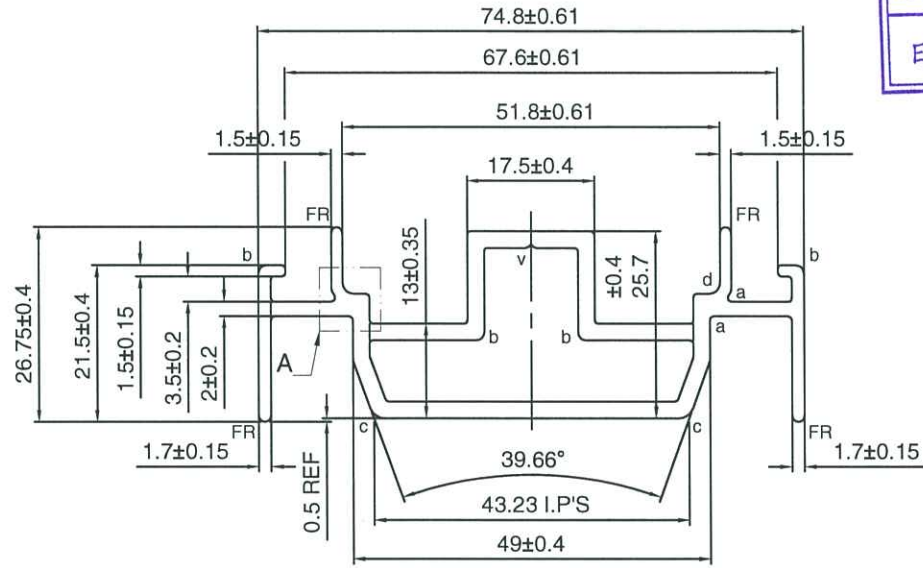

v=0.5X90°
a=R0.5 b=R1 c=R2 d=R1.5
= = = 次要裝飾面, 噴塗膜厚不足, 但不露底
- - - 裝飾面
●●●●● 凹槽位置可能有露底現象, 即膜厚不足
备注: 没有配合型号!

V.F

SCALE 1:1

AREA (SQ MM)	486.49	UNSPECIFIED THICKNESS	2.3±0.25	PERIMETER (MM)	326.56	STANDARD	BS EN755	SCALE	2:1
MASS (KG/M)	1.318	UNSPECIFIED CORNERS	R 0.4	SURFACE AREA	173.93	ALLOY	6063-T6	VERSION	A
COMPANY ISSUE	-	DRAWN	黃瓊玉	DATE	2023-05-19	APPELLATION	-	PAGE OF	
		STANDARDIZATION		DATE					
		TO SIGN		DATE					
		AUDITING		DATE					
MARKER	MODIFY FILE NO	SIGNATURE	DATE	APPROV	DATE				

CUSTOMER	HONGKONG CO.	CUSTOMER APPROVAL	CUST PART NO.	X86479
			SECTION NO.	

美特鋁質有限公司	
承認圖面	<i>Jan</i>
日期	25.5.2023

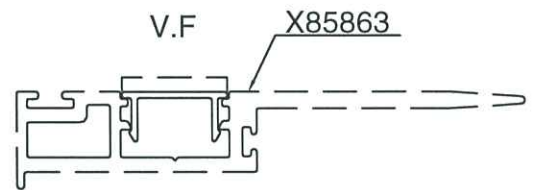
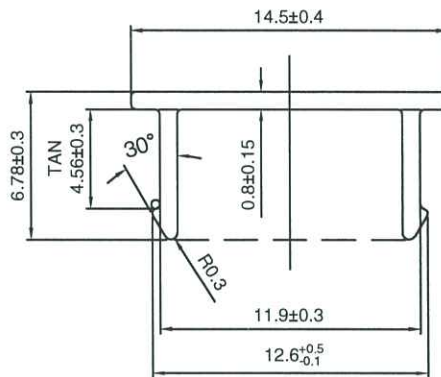

SCALE 1:1

*配合尺寸以实物配合效果为准!

AREA (SQ MM)	21.32	UNSPECIFIED THICKNESS	0.8±0.15	PERIMETER (MM)	53.56	STANDARD	BS EN755	SCALE	3:1
MASS (KG/M)	0.059	UNSPECIFIED CORNERS	R 0.2	SURFACE AREA	14.73	ALLOY	6063-T5	VERSION	A
COMPANY ISSUE	-	DRAWN	黃瓊玉	DATE	2023-05-19	APPELLATION	-	PAGE OF	
		STANDARDIZATION		DATE		 美特鋁質有限公司 MIDI Aluminium Fabricator Ltd.			
		TO SIGN		DATE					
		AUDITING		DATE					
MARKER	MODIFY	FILE NO	SIGNATURE	DATE	APPROV				

CUSTOMER	HONGKONG CO.	CUSTOMER APPROVAL	CUST PART NO.	X86480
			SECTION NO.	

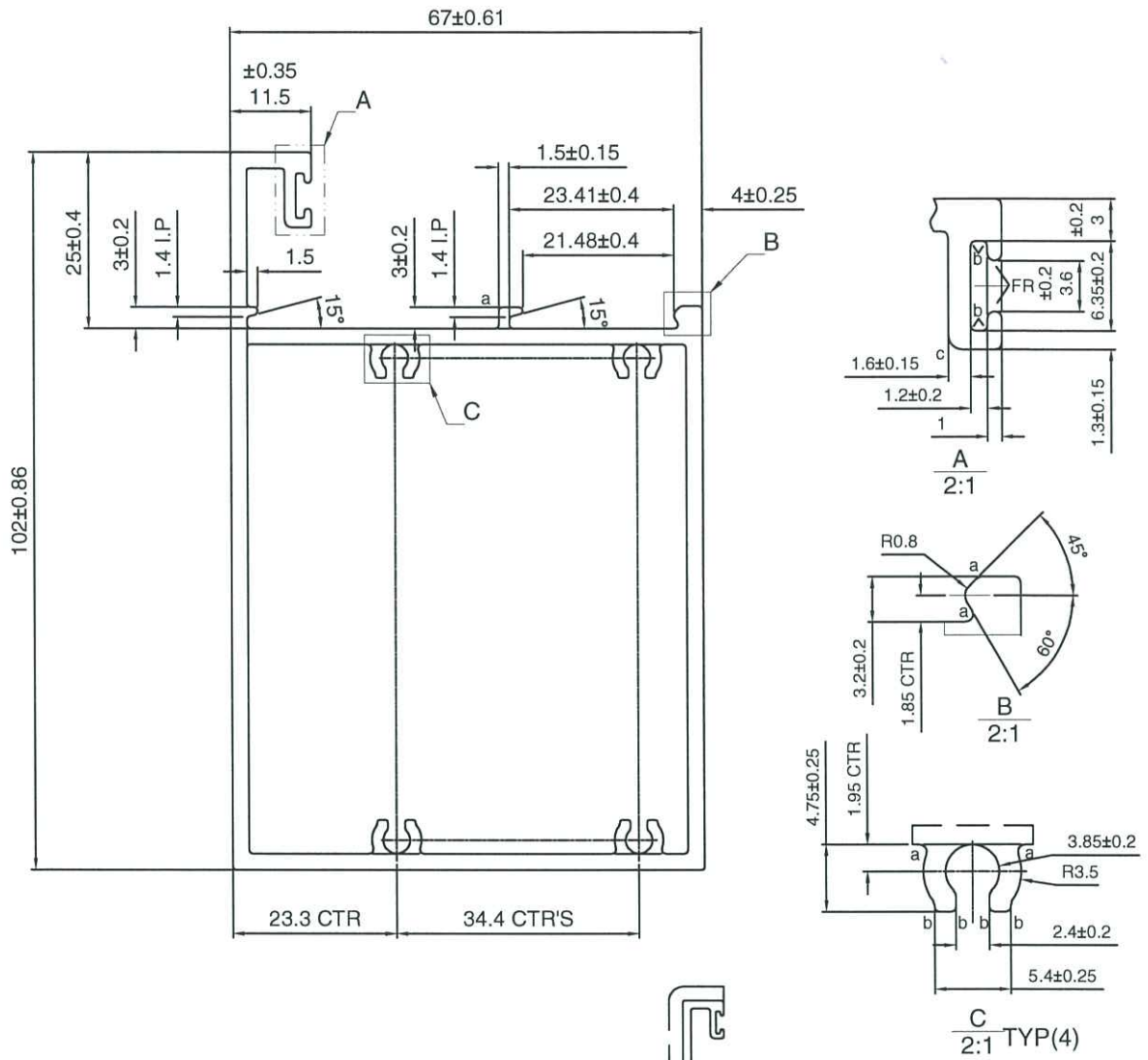

a=R0.5
b=R0.3
c=R1

备注：没有配合型号！

美特鋁質有限公司	
承認圖面	<i>[Signature]</i>
日期	25.5.2023

SCALE 1:2

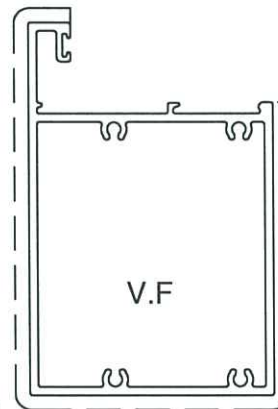

AREA (SQ MM)	826.65	UNSPECIFIED THICKNESS	2.3±0.25	PERIMETER (MM)	396.50	STANDARD	BS EN755	SCALE	1:1
MASS (KG/M)	2.240	UNSPECIFIED CORNERS	R 0.4	SURFACE AREA	260.64	ALLOY	6063-T6	VERSION	A
COMPANY ISSUE	-	DRAWN	黃瓊玉	DATE	2023-05-19	APPELLATION	-	PAGE OF	
		STANDARDIZATION		DATE					
		TO SIGN		DATE					
		AUDITING		DATE					
MARKER	MODIFY	FILE NO	SIGNATURE	DATE	APPROV	DATE			

CUSTOMER	HONGKONG CO.	CUSTOMER APPROVAL	CUST PART NO.	XB6481
			SECTION NO.	

美特鋁質有限公司

承認圖面	
日期	25.5.2023

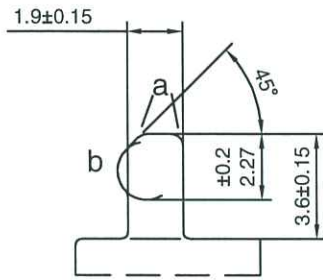
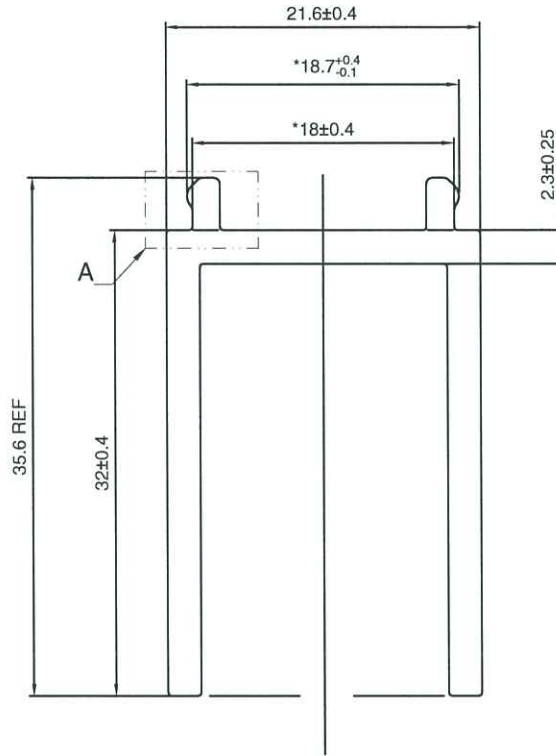

A
4:1 TYP(2)

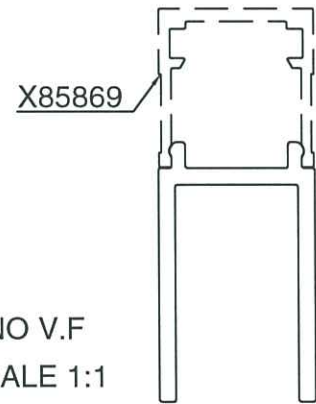

a=R0.4 b=R1

*配合尺寸以实物配合效果为准!

AREA (SQ MM)	200.41	UNSPECIFIED THICKNESS	2.3±0.25	PERIMETER (MM)	179.39	STANDARD	BS EN755	SCALE	2:1
MASS (KG/M)	0.543	UNSPECIFIED CORNERS	R 0.2	SURFACE AREA	-	ALLOY	6063-T6	VERSION	A
COMPANY ISSUE	-	DRAWN	黃瓊玉	DATE	2023-05-19	APPELLATION	-	PAGE OF	
		STANDARDIZATION		DATE		美特鋁質有限公司 MIDI Aluminium Fabricator Ltd.			
		TO SIGN		DATE					
		AUDITING		DATE					
MARKER	MODIFY	FILE NO	SIGNATURE	DATE	APPROV				

CUSTOMER	HONGKONG CO.	CUSTOMER APPROVAL	CUST PART NO.	X86482
			SECTION NO.	

美特鋁質有限公司

承認圖面	
日期	2023.5.15

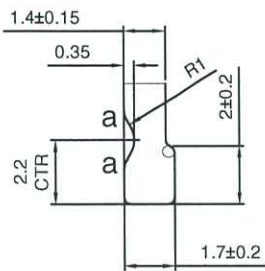
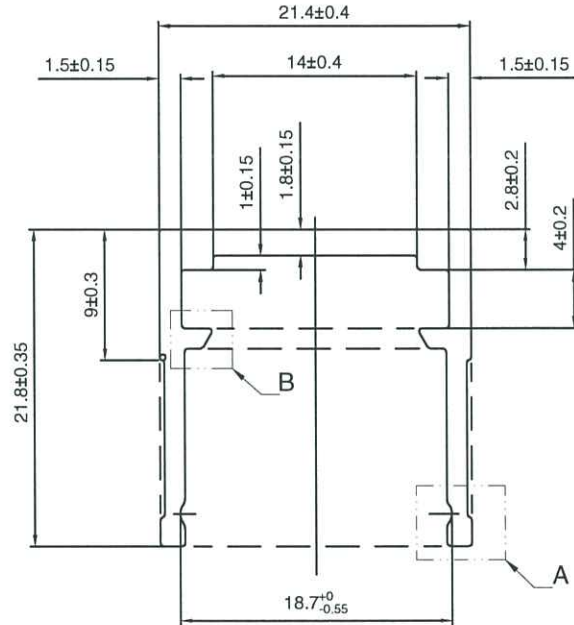

A
4:1 TYP(2)

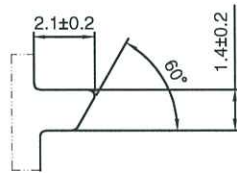

B
4:1 TYP(2)

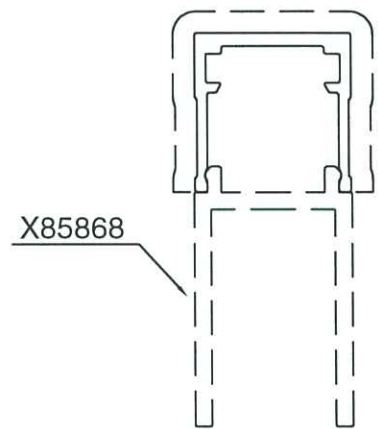

X85868

SCALE 1:1

a=R0.5

*配合尺寸以实物配合效果为准!

AREA (SQ MM)	106.22	UNSPECIFIED THICKNESS	1.4±0.15	PERIMETER (MM)	133.13	STANDARD	BS EN755	SCALE	2:1
MASS (KG/M)	0.288	UNSPECIFIED CORNERS	R 0.2	SURFACE AREA	65.62	ALLOY	6063-T6	VERSION	A
COMPANY ISSUE	-	DRAWN	黃瓊玉	DATE	2023-05-19	APPELLATION	-	PAGE OF	
		STANDARDIZATION		DATE		<p style="text-align: center;">美特鋁質有限公司 MIDI Aluminium Fabricator Ltd.</p>			
		TO SIGN		DATE					
		AUDITING		DATE					
MARKER	MODIFY	FILE NO	SIGNATURE	DATE	APPROV				

CUSTOMER	HONGKONG CO.	CUSTOMER APPROVAL	CUST PART NO.	x86483
			SECTION NO.	

美特鋁質有限公司	
承認圖面	
日期	25.5.2023

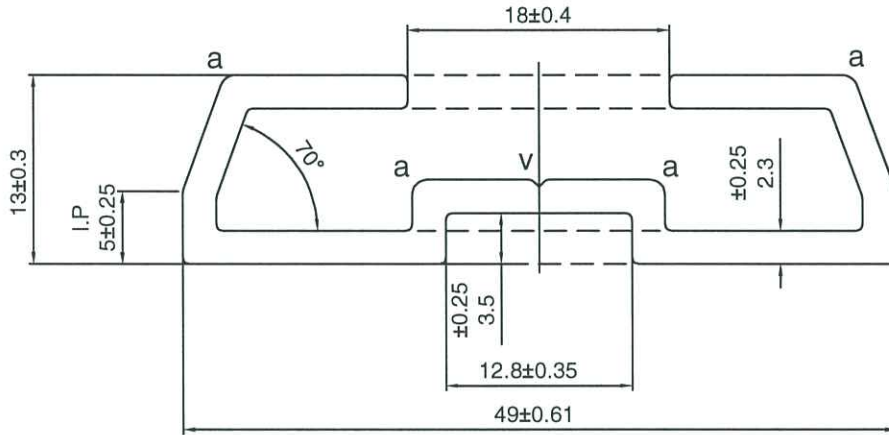

(V.F)

SCALE 1:1

v=0.5X90°

a=R1

— — — 装饰面

●●●●●● 凹槽位置可能會有露底現象，即膜厚不足

*配合尺寸以实物配合效果为准！

AREA (SQ MM)	228.11	UNSPECIFIED THICKNESS	2.3±0.25	PERIMETER (MM)	200.35	STANDARD	BS EN755	SCALE	2:1
MASS (KG/M)	0.618	UNSPECIFIED CORNERS	R 0.4	SURFACE AREA	145.84	ALLOY	6063-T6	VERSION	A
COMPANY ISSUE	-	DRAWA	黃瓊玉	DATE	2023-05-19	APELLATION	-	PAGE OF	
		STANDA-RDIZATION		DATE					
		TO SIGN		DATE					
		AUDITING		DATE					
MARKER	MODIFY	FILE NO	SIGNATURE	DATE	APPROV				

CUSTOMER	HONGKONG CO.	CUSTOMER APPROVAL	CUST PART NO.	X86484
			SECTION NO.	

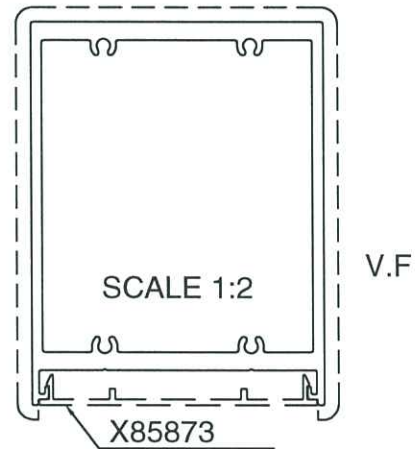
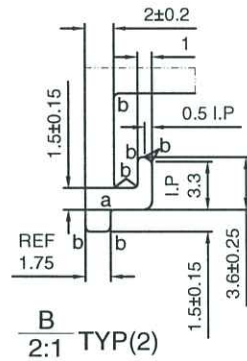
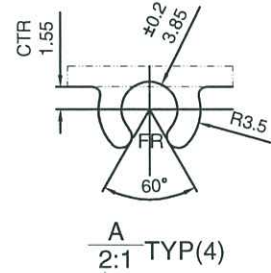
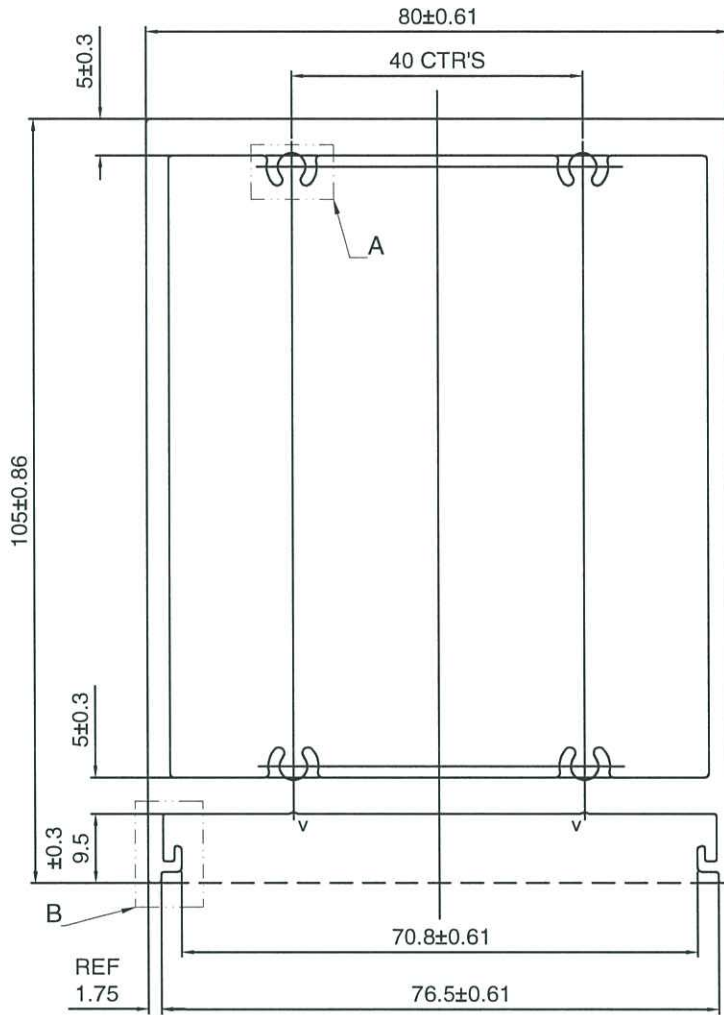

a=R0.2
b=R0.3
v=0.3X90°

*配合尺寸以实物配合效果为准!

美特鋁質有限公司	
承認圖面	<i>Jur</i>
日期	25.5.2023

AREA (SQ MM)	1414.85	UNSPECIFIED THICKNESS	3.0±0.25	PERIMETER (MM)	405.13	STANDARD	BS EN755	SCALE	1:1
MASS (KG/M)	3.834	UNSPECIFIED CORNERS	R 0.5	SURFACE AREA	293.16	ALLOY	6063-T6	VERSION	A
COMPANY ISSUE	-	DRAWN	黃瓊玉	DATE	2023-05-19	APPELLATION	-	PAGE OF	
		STANDARDIZATION		DATE		 美特鋁質有限公司 MIDI Aluminium Fabricator Ltd.			
		TO SIGN		DATE					
		AUDITING		DATE					
MARKER	MODIFY	FILE NO	SIGNATURE	DATE	APPROV				

CUSTOMER	HONGKONG CO.	CUSTOMER APPROVAL	CUST PART NO.	X86485
			SECTION NO.	

美特鋁質有限公司
承認圖面 *Jue*
日期 25.5.2023

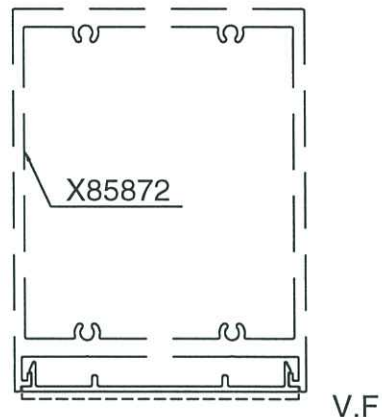
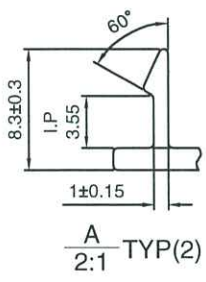
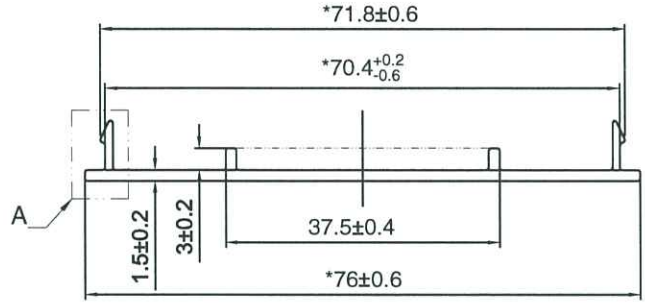

SCALE 1:2

*配合尺寸以实物配合效果为准!

AREA (SQ MM)	137.66	UNSPECIFIED THICKNESS	1.5±0.15	PERIMETER (MM)	191.99	STANDARD	BS EN755	SCALE	1:1
MASS (KG/M)	0.373	UNSPECIFIED CORNERS	R 0.3	SURFACE AREA	76.34	ALLOY	6063-T5	VERSION	A
COMPANY ISSUE	-	DRAWN	黃瓊玉	DATE	2023-05-19	APPELLATION	-	PAGE OF	
		STANDARDIZATION		DATE		 美特鋁質有限公司 MIDI Aluminium Fabricator Ltd.			
		TO SIGN		DATE					
		AUDITING		DATE					
MARKER	MODIFY	FILE NO	SIGNATURE	DATE	APPROV				

CUSTOMER	HONGKONG CO.	CUSTOMER APPROVAL	CUST PART NO.	X86486
			SECTION NO.	

美特鋁質有限公司	
承認圖面	<i>[Signature]</i>
日期	25.5.2023

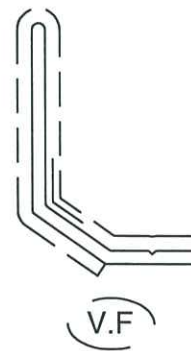
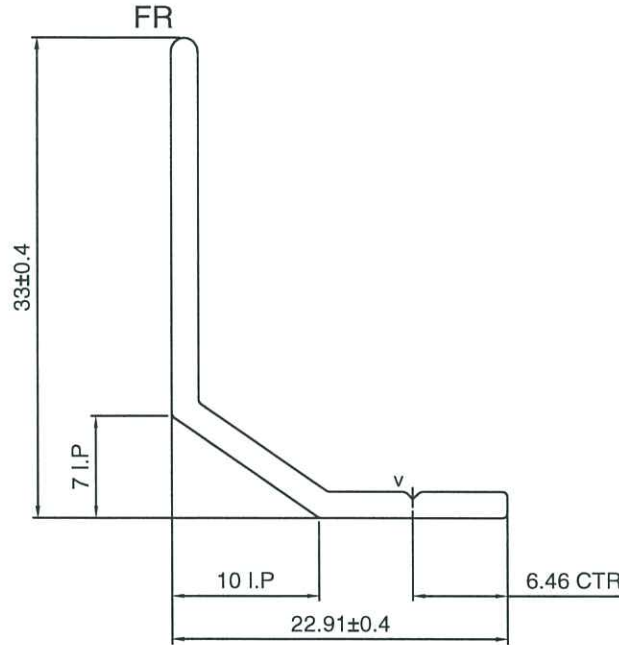

SCALE 1:1

$v=0.5 \times 90^\circ$

== 次要装饰面, 喷涂膜厚不足, 但不露底

- - - 装饰面

备注: 没有配合型号!

AREA (SQ MM)	88.66	UNSPECIFIED THICKNESS	1.8±0.15	PERIMETER (MM)	102.13	STANDARD	BS EN755	SCALE	2:1
MASS (KG/M)	0.240	UNSPECIFIED CORNERS	R 0.3	SURFACE AREA	87.94	ALLOY	6063-T6	VERSION	A
COMPANY ISSUE	-	DRAWN	黃瓊玉	DATE	2023-05-19	APPELLATION	-	PAGE OF	
		STANDARDIZATION		DATE		 美特鋁質有限公司 MIDI Aluminium Fabricator Ltd.			
		TO SIGN		DATE					
		AUDITING		DATE					
MARKER	MODIFY	FILE NO	SIGNATURE	DATE	APPROV				

CUSTOMER	HONGKONG CO.	CUSTOMER APPROVAL	CUST PART NO.	X86487
			SECTION NO.	

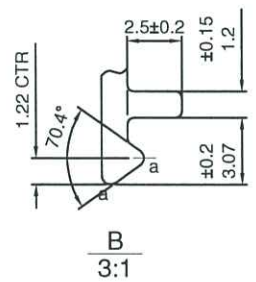
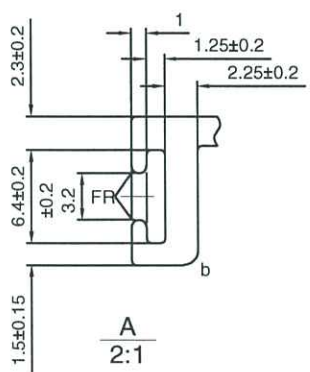
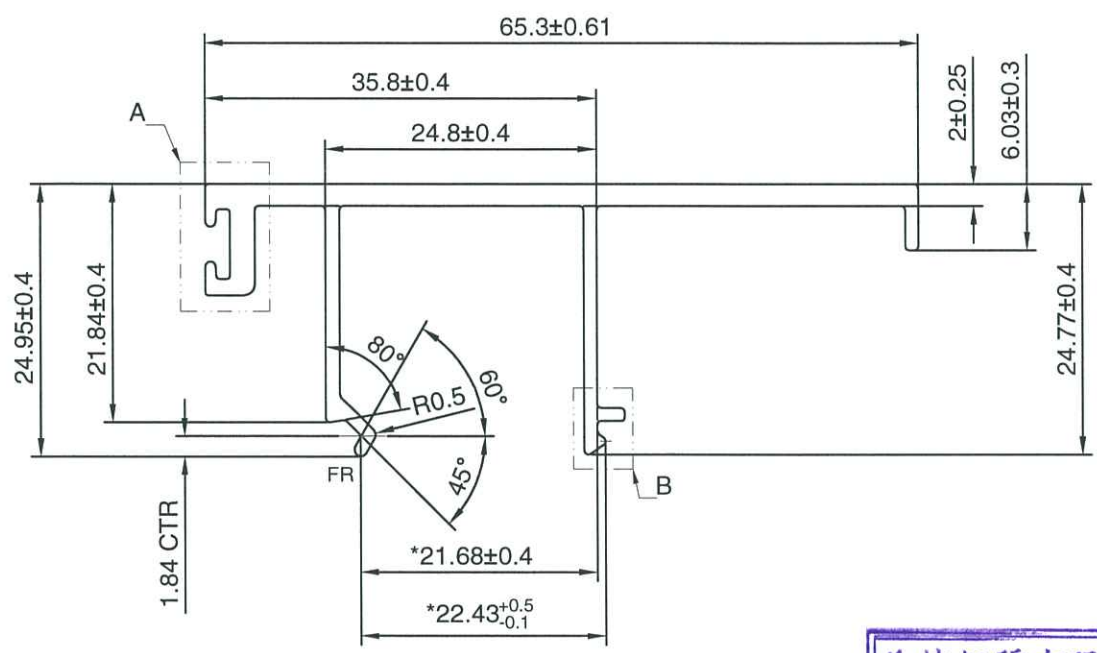

美特鋁質有限公司
承認圖面
日期 2023.5.20

V.F

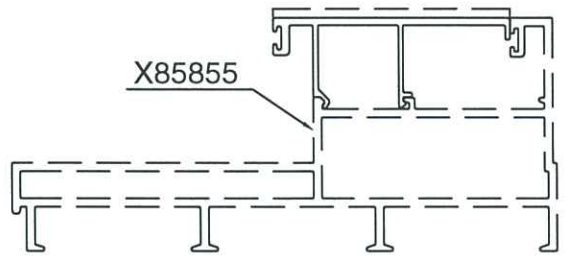

SCALE 1:2

a=R0.4
b=R1

*配合尺寸以实物配合效果为准!

AREA (SQ MM)	224.40	UNSPECIFIED THICKNESS	1.2±0.15	PERIMETER (MM)	266.33	STANDARD	BS EN755	SCALE	1.5:1
MASS (KG/M)	0.609	UNSPECIFIED CORNERS	R 0.3	SURFACE AREA	65.64	ALLOY	6063-T6	VERSION	A
COMPANY ISSUE	-	DRAWN	黃瓊玉	DATE	2023-05-19	APPELLATION	-	PAGE OF	
		STANDARDIZATION		DATE					
		TO SIGN		DATE					
		AUDITING		DATE					
MARKER	MODIFY	FILE NO	SIGNATURE	DATE	APPROV				

CUSTOMER	HONGKONG CO.	CUSTOMER APPROVAL	CUST PART NO.	X86488
			SECTION NO.	

美特鋁質有限公司
承認圖面
日期 2023.5.20

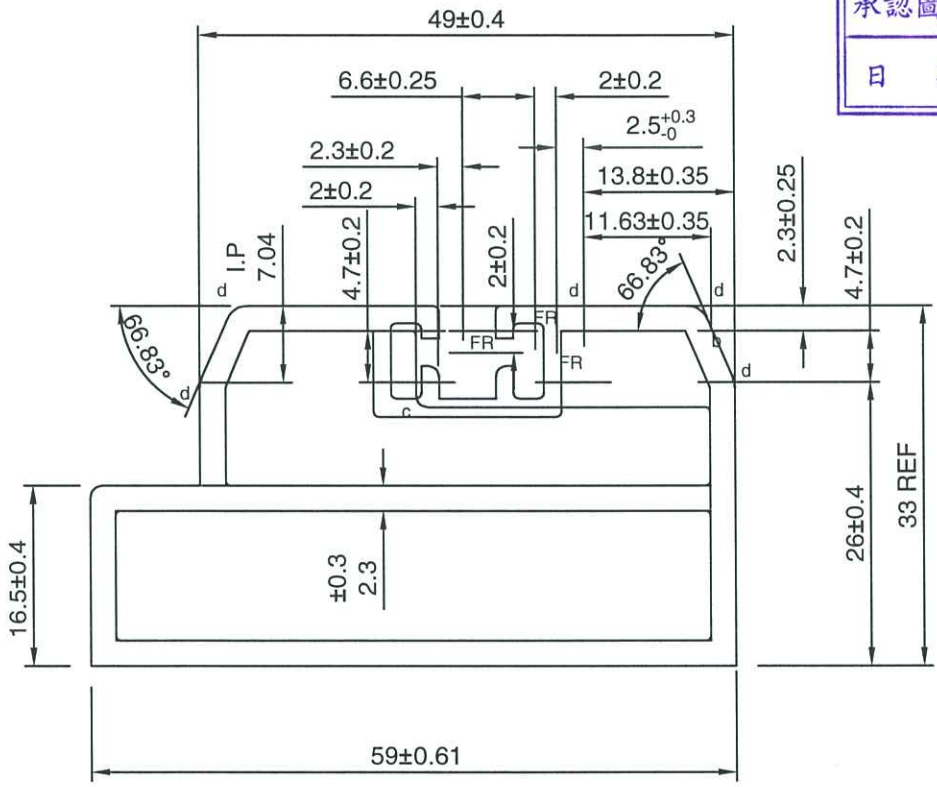

a=R0.5
b=R0.3
c=R1 d=R2
= = = 次要裝飾面，噴塗膜厚不足，但不露底
- - - 裝飾面
●●●●● 凹槽位置可能有露底現象，即膜厚不足
*配合尺寸以實物配合效果為準！

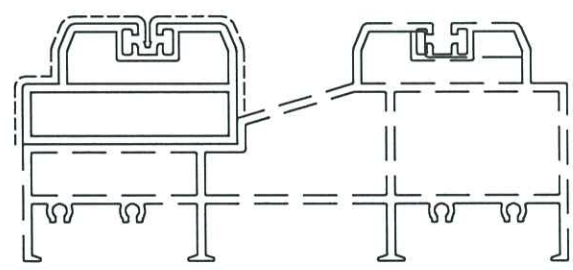

SCALE 1:2 (V.F)

AREA (SQ MM)	551.71	UNSPECIFIED THICKNESS	2.3±0.25	PERIMETER (MM)	227.78	STANDARD	BS EN755	SCALE	1.5:1
MASS (KG/M)	1.495	UNSPECIFIED CORNERS	R 0.4	SURFACE AREA	146.26	ALLOY	6063-T6	VERSION	A
COMPANY ISSUE	-	DRAWN	黃瓊玉	DATE	2023-05-19	APPELLATION	-	PAGE OF	
		STANDARDIZATION		DATE					
		TO SIGN		DATE					
		AUDITING		DATE					
MARKER	MODIFY	FILE NO	SIGNATURE	DATE	APPROV				

CUSTOMER	HONGKONG CO.	CUSTOMER APPROVAL	CUST PART NO.	X86489
			SECTION NO.	

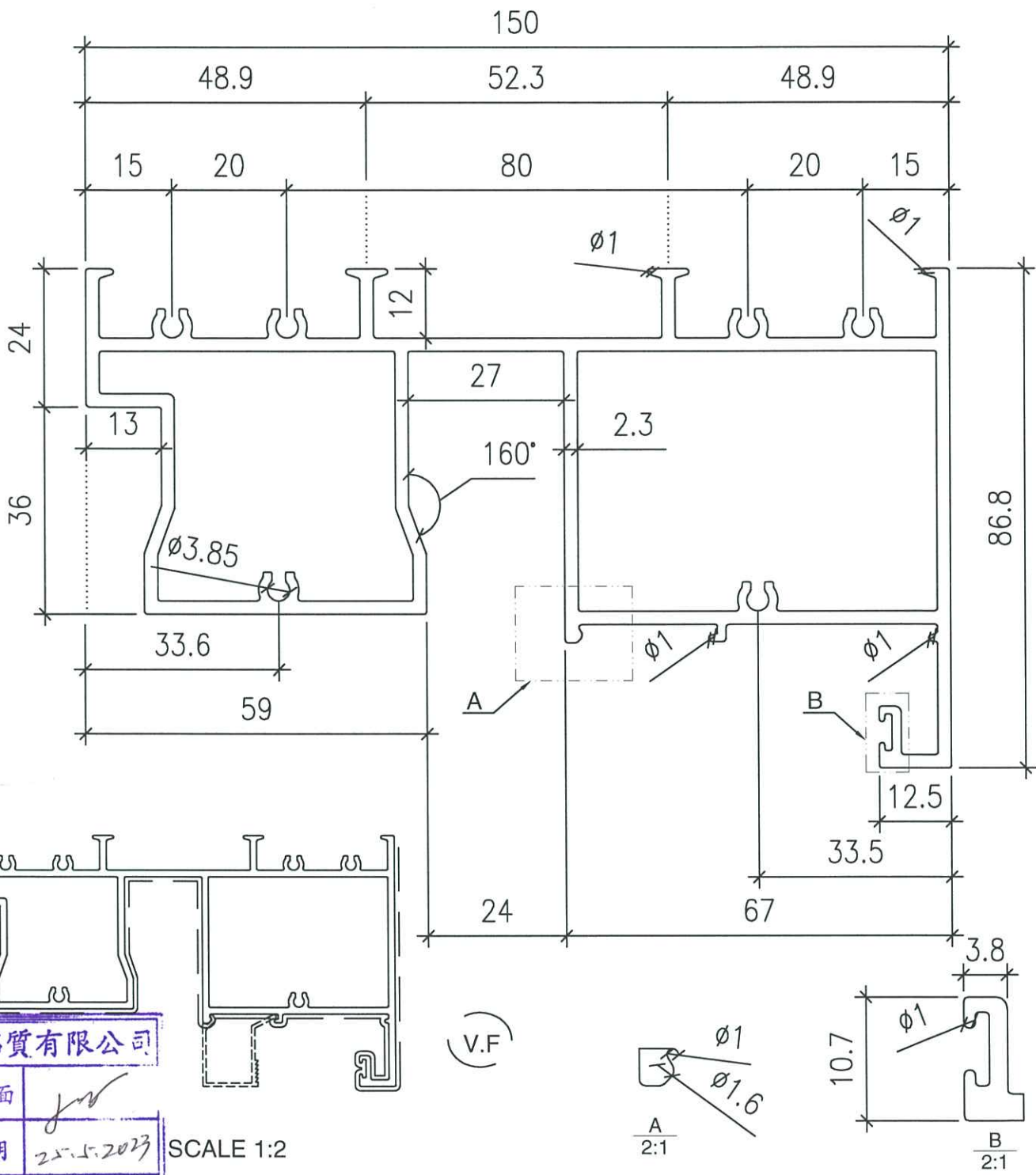

美特鋁質有限公司
承認圖面
日期 25.5.2023

SCALE 1:2

AREA (SQ MM)	1403.29	UNSPECIFIED THICKNESS	2.3	PERIMETER (MM)	1248.52	STANDARD	BS EN755	SCALE	-
MASS (KG/M)	3.803	UNSPECIFIED CORNERS	R 0.3	SURFACE AREA	481.11	ALLOY	6063-T6	VERSION	-
COMPANY ISSUE	-	DRAWN	黃瓊玉	DATE	2023-05-19	APPELLATION	-	PAGE OF	
		STANDARDIZATION		DATE					
		TO SIGN		DATE					
		AUDITING		DATE					
MARKER	MODIFY	FILE NO	SIGNATURE	DATE	APPROV				



CUSTOMER	HONGKONG CO.	CUSTOMER APPROVAL	CUST PART NO.	X86490
			SECTION NO.	

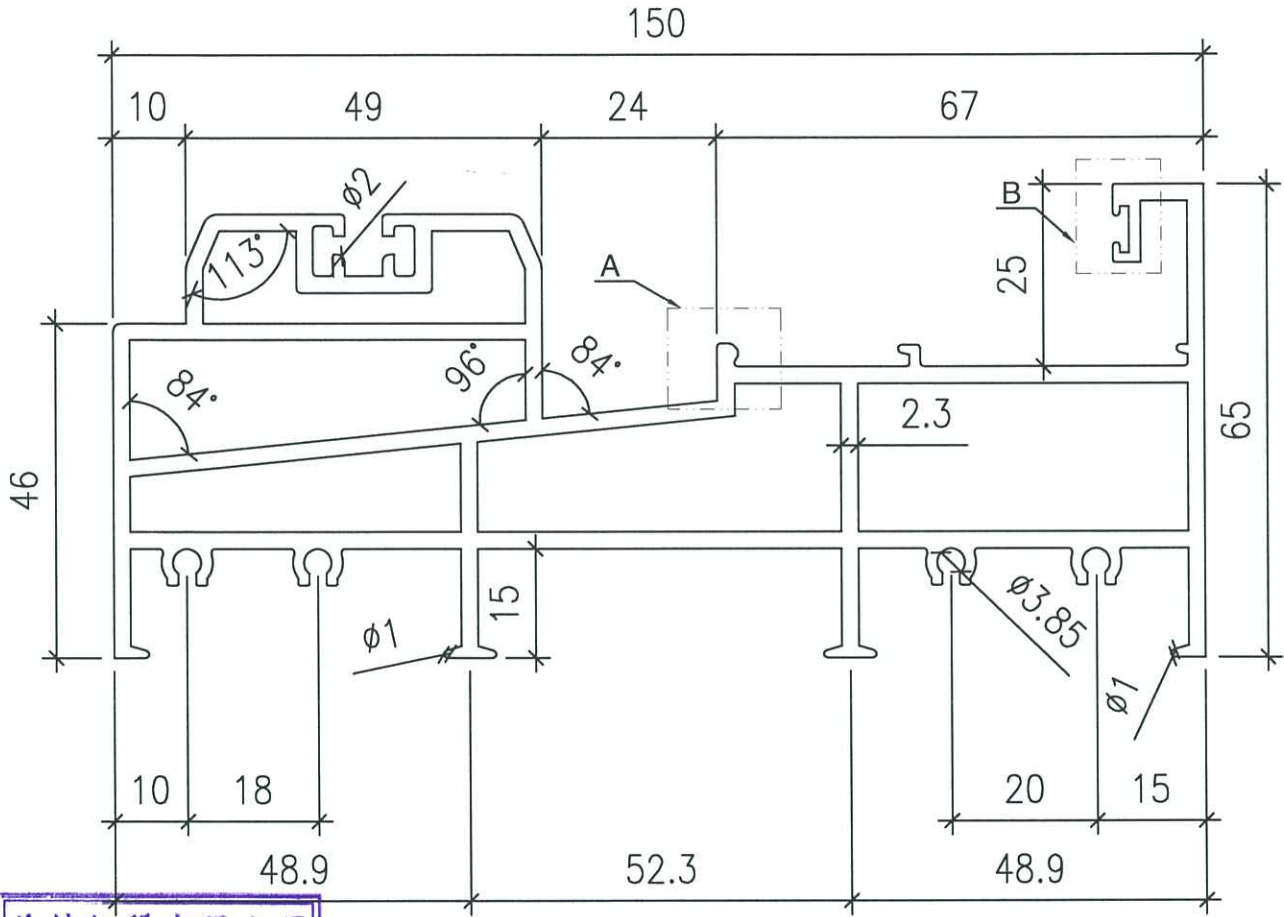

美特鋁質有限公司	
承認圖面	<i>[Signature]</i>
日期	25.5.2023

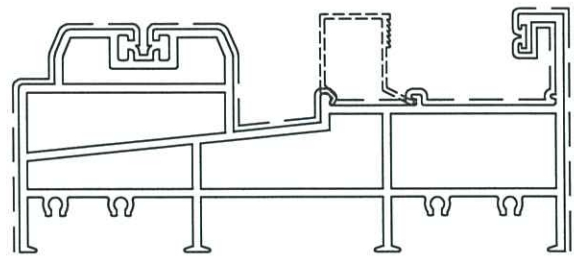
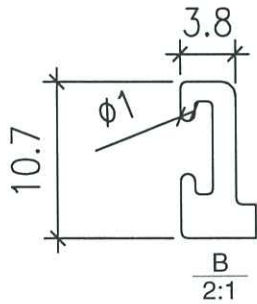
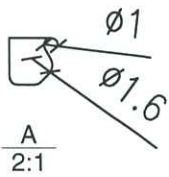

(V.F)

SCALE 1:2

AREA (SQ MM)	1612.95	UNSPECIFIED THICKNESS	2.3	PERIMETER (MM)	1423.36	STANDARD	BS EN755	SCALE	-
MASS (KG/M)	4.371	UNSPECIFIED CORNERS	R 0.3	SURFACE AREA	439.11	ALLOY	6063-T6	VERSION	-
COMPANY ISSUE	-	DRAWN	黃瓊玉	DATE	2023-05-19	APPELLATION	-	PAGE OF	
		STANDARDIZATION		DATE		 美特鋁質有限公司 MIDI Aluminium Fabricator Ltd.			
		TO SIGN		DATE					
		AUDITING		DATE					
MARKER	MODIFY	FILE NO	SIGNATURE	DATE	APPROV				

CUSTOMER	HONGKONG CO.	CUSTOMER APPROVAL	CUST PART NO.	x86491
			SECTION NO.	

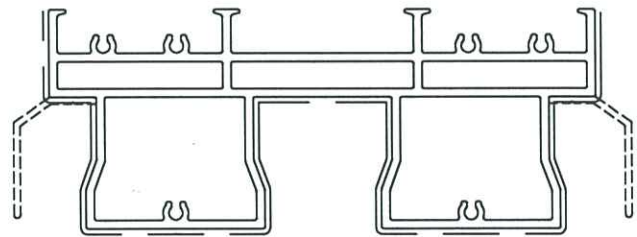
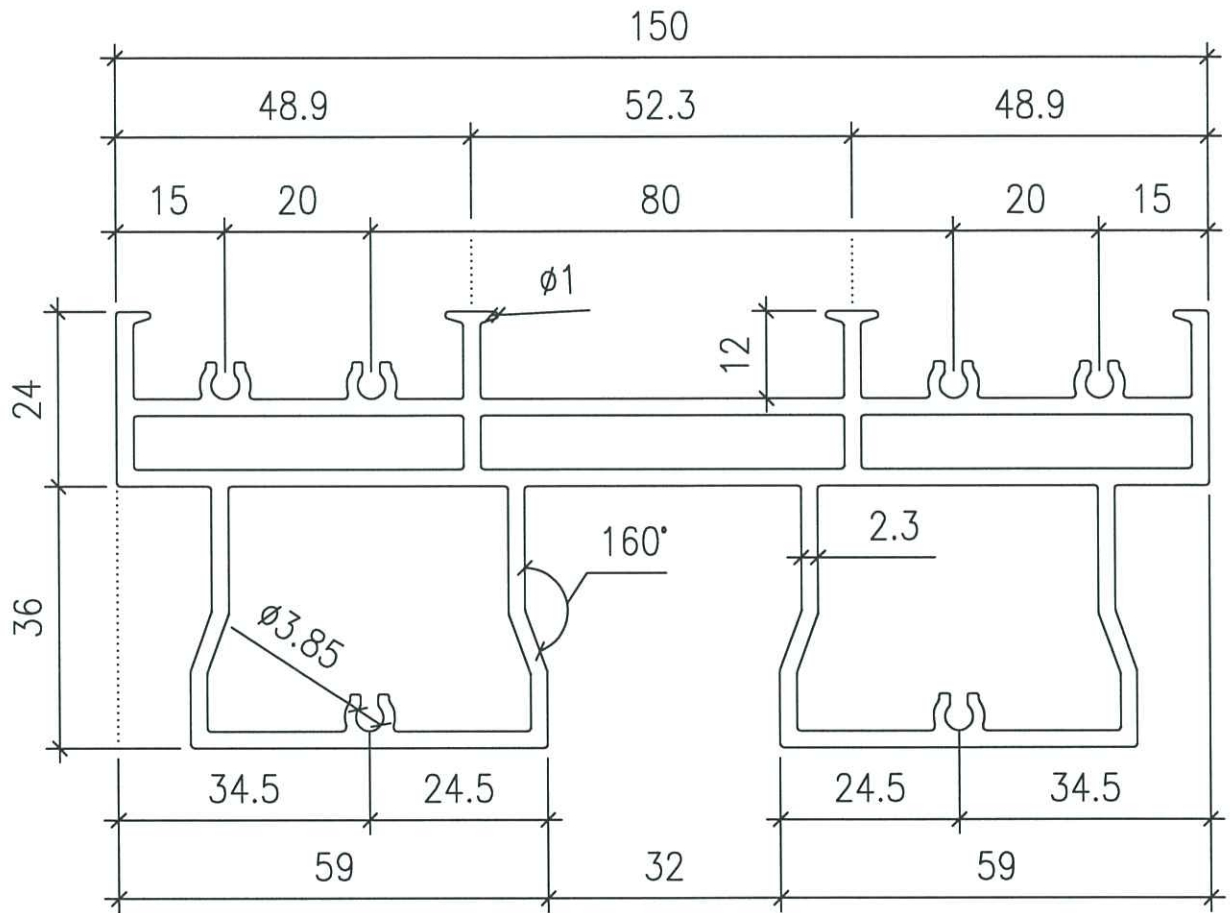

SCALE 1:2

V.F

美特鋁質有限公司	
承認圖面	
日期	25.5.2023

AREA (SQ MM)	1532.85	UNSPECIFIED THICKNESS	2.3	PERIMETER (MM)	1336.98	STANDARD	BS EN755	SCALE	-
MASS (KG/M)	4.154	UNSPECIFIED CORNERS	R 0.3	SURFACE AREA	354.39	ALLOY	6063-T6	VERSION	-
COMPANY ISSUE	-	DRAWN	黃瓊玉	DATE	2023-05-19	APPELLATION	-	PAGE OF	
		STANDARDIZATION		DATE					
		TO SIGN		DATE					
		AUDITING		DATE					
MARKER	MODIFY	FILE NO	SIGNATURE	DATE	APPROV				

CUSTOMER	HONGKONG CO.	CUSTOMER APPROVAL	CUST PART NO.	X86493
			SECTION NO.	

美特鋁質有限公司
承認圖面
日期 2023.05.19

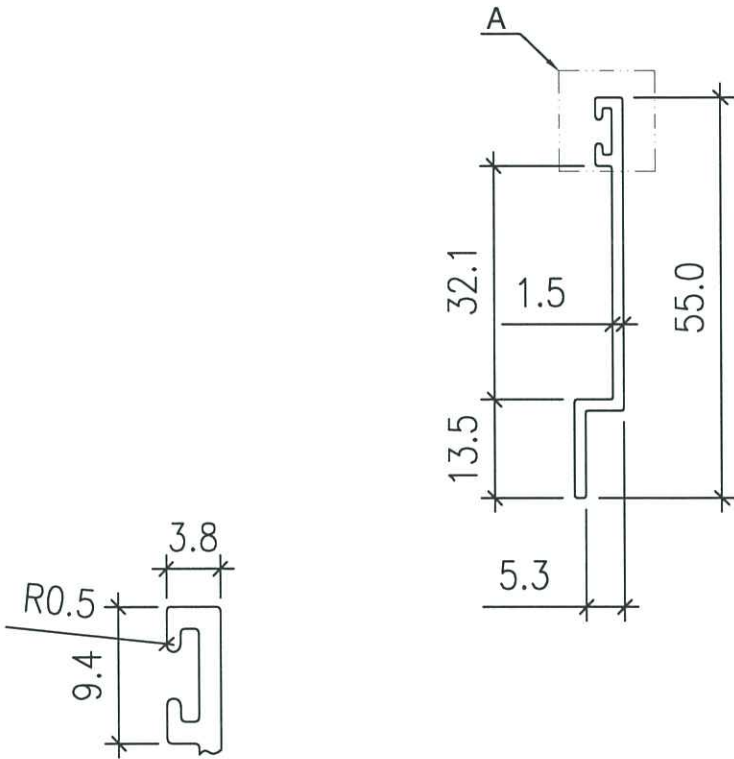

A
2:1

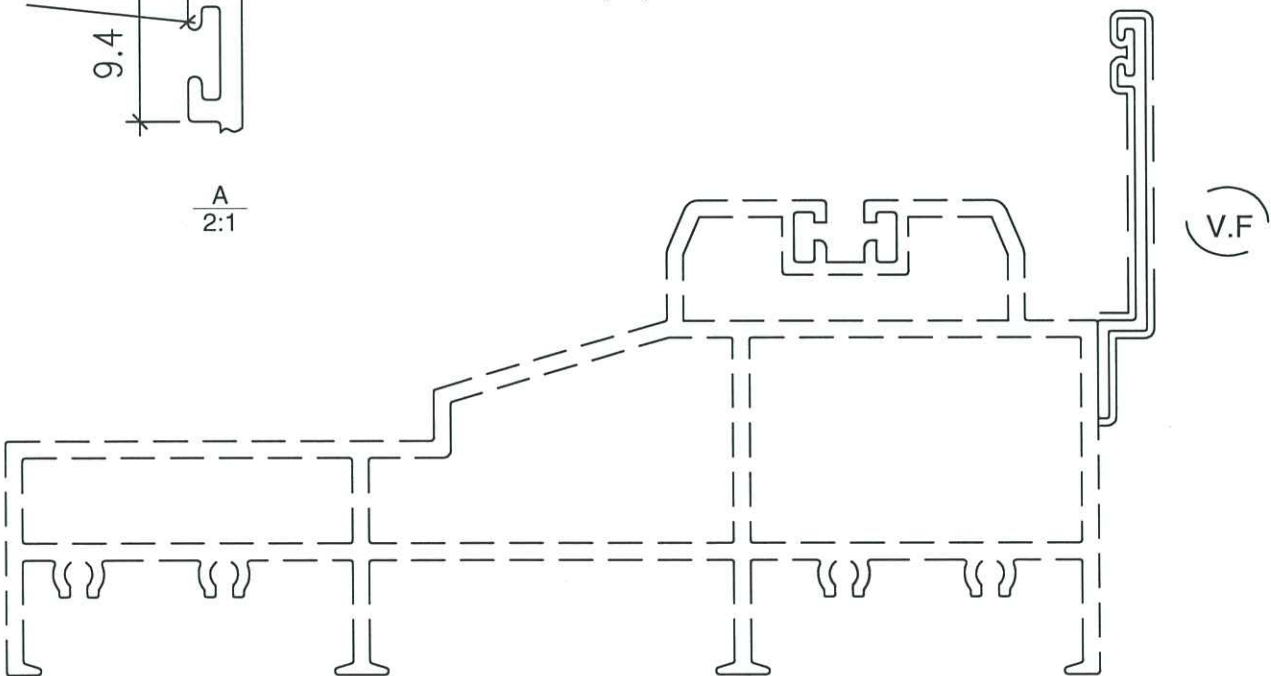

SCALE 1:1

AREA (SQ MM)	100.13	UNSPECIFIED THICKNESS	1.5	PERIMETER (MM)	136.32	STANDARD	BS EN755	SCALE	-
MASS (KG/M)	0.271	UNSPECIFIED CORNERS	R 0.3	SURFACE AREA	123.04	ALLOY	6063-T6	VERSION	-
COMPANY ISSUE	-	DRAWN	黃瓊玉	DATE	2023-05-19	APPELLATION	-	PAGE OF	
		STANDARDIZATION		DATE					
		TO SIGN		DATE					
		AUDITING		DATE					
MARKER	MODIFY	FILE NO	SIGNATURE	DATE	APPROV				