



工程指示 / 要求簡箋 ENGINEER INSTRUCTIONS(E.I.)

工程指示編號:	EI- 6252	修改版本:	-
	HK-1181		
工程編號:	J 856	工程名稱:	天榮站
收件人:	生統 / Maggie	發件人:	Jingo
工程項目:	隔音窗鋁料模圖	日期:	25/05/2023

<input checked="" type="checkbox"/> 原合約工程包	<input type="checkbox"/> 原合約工程加 / 減賬 QT-	<input type="checkbox"/> 新工程報價 QT-
--	--	------------------------------------

信件批核號碼/圖紙參考編號:	批核模具圖紙編號:
客戶指示附件:	管理內部批簽署:

<input type="checkbox"/> 初步鋁料 B.M.	<input type="checkbox"/> 加工拆圖, 然後生產	<input type="checkbox"/> 尺寸表
<input type="checkbox"/> 正式鋁料 B.M.	<input type="checkbox"/> 技術上資料/指示	<input type="checkbox"/> 報價
<input type="checkbox"/> 配件 B.M.	<input type="checkbox"/> 樣辦或貨品說明書	<input type="checkbox"/> 分判合約
<input type="checkbox"/> 其他:		

內容: 請安排隔音窗鋁料新模圖7個 X86465, X86466, X86467, X86468, X86469, X86470, X86471 預算完成模圖: 2/6/2023 完成開模及試模: 23/6/2023
完成上列要求日期: _____

國內

<input type="checkbox"/> 生產技術總監	<input type="checkbox"/> 連附件	<input checked="" type="checkbox"/> 技術部	<input checked="" type="checkbox"/> 連附件	<input type="checkbox"/> 生產部	<input type="checkbox"/> 連附件
<input type="checkbox"/> 採購部	<input type="checkbox"/> 連附件	<input checked="" type="checkbox"/> 生產統籌部	<input checked="" type="checkbox"/> 連附件	<input type="checkbox"/> 報關組	<input type="checkbox"/> 連附件
<input checked="" type="checkbox"/> 質檢部	<input checked="" type="checkbox"/> 連附件	<input type="checkbox"/> 會計部	<input type="checkbox"/> 連附件	<input type="checkbox"/> 機械設計部	<input type="checkbox"/> 連附件
<input type="checkbox"/> 香港辦	<input type="checkbox"/> 連附件	<input type="checkbox"/> 其他:			

香港

<input type="checkbox"/> 行政部	<input type="checkbox"/> 連附件	<input type="checkbox"/> 會計部	<input type="checkbox"/> 連附件	<input type="checkbox"/> 統籌部	<input type="checkbox"/> 連附件	<input type="checkbox"/> 工程部	<input type="checkbox"/> 連附件
<input checked="" type="checkbox"/> 採購部	<input checked="" type="checkbox"/> 連附件	<input type="checkbox"/> QS部	<input type="checkbox"/> 連附件	<input type="checkbox"/> 地盤管理	<input type="checkbox"/> 連附件	<input type="checkbox"/> 維修部	<input type="checkbox"/> 連附件

*發件人簽署: Jingo	*組別成員批核簽署:
傳遞編號:	項目經理簽署:

CUSTOMER	HONGKONG CO.	CUSTOMER APPROVAL	CUST PART NO.	X86465
			SECTION NO.	

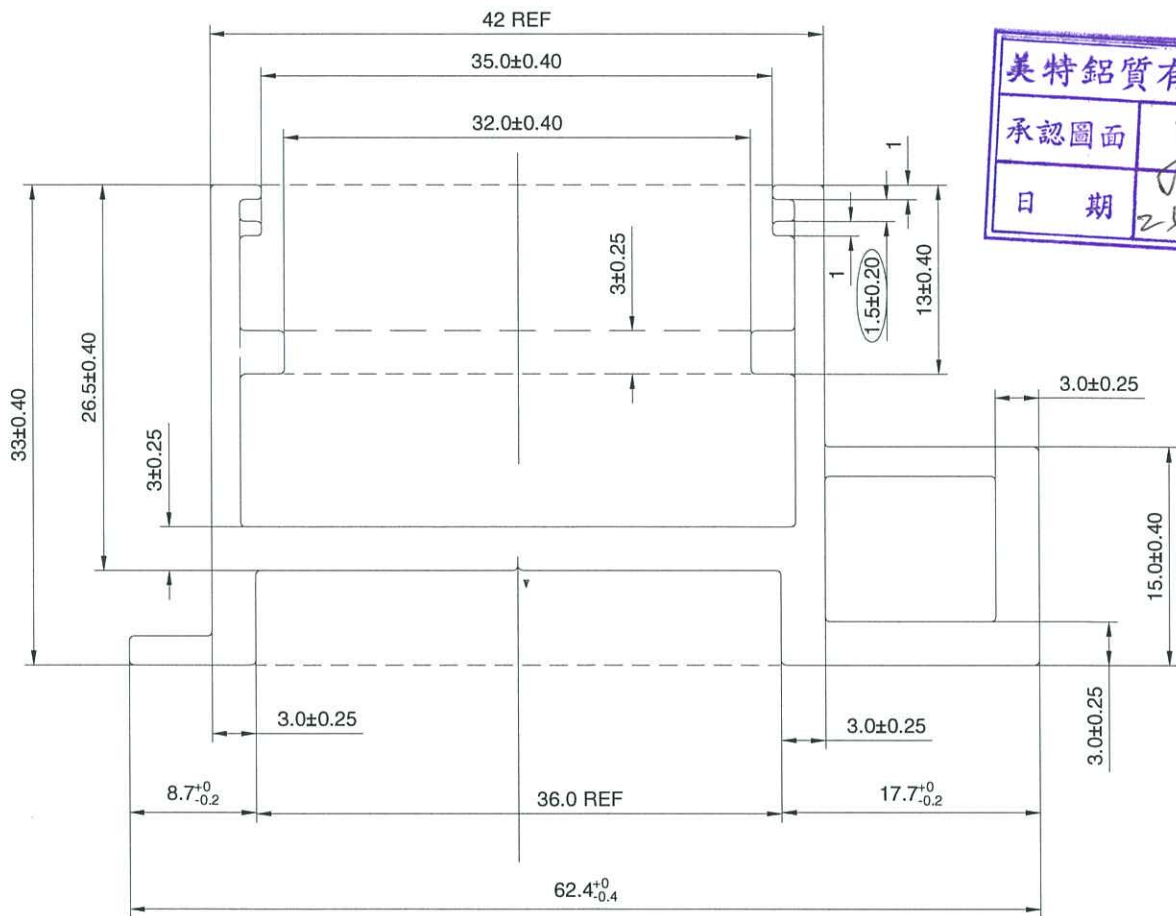

美特鋁質有限公司
承認圖面
日期 25.5.2023

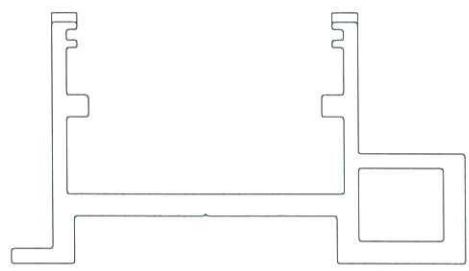
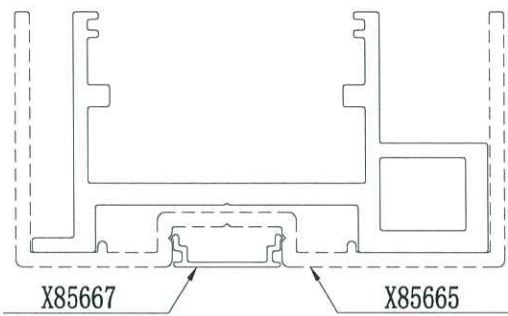

v=0.3X90°

--- 裝飾面

SCALE 1:1

*配合尺寸以实物配合效果为准!

V.F
SCALE 1:1

AREA (SQ MM)	397.83	UNSPECIFIED THICKNESS	2±0.2	PERIMETER (MM)	270.35	STANDARD	BS EN755	SCALE	2:1
MASS (KG/M)	1.078	UNSPECIFIED CORNERS	R 0.3	SURFACE AREA	7.68	ALLOY	6063-T5	VERSION	-
COMPANY ISSUE	-	DRAWN	黃瓊玉	DATE	2023-05-19	APELLATION	-	PAGE	OF
		STANDARDIZATION		DATE					
		TO SIGN		DATE					
		AUDITING		DATE					
MARKER	MODIFY FILE NO	SIGNATURE	DATE	APPROV	DATE				

美特鋁質有限公司
MIDI Aluminium Fabricator Ltd.

CUSTOMER	HONGKONG CO.	CUSTOMER APPROVAL	CUST PART NO.	486466
			SECTION NO.	

美特鋁質有限公司	
承認圖面	<i>[Signature]</i>
日期	25.5.2023

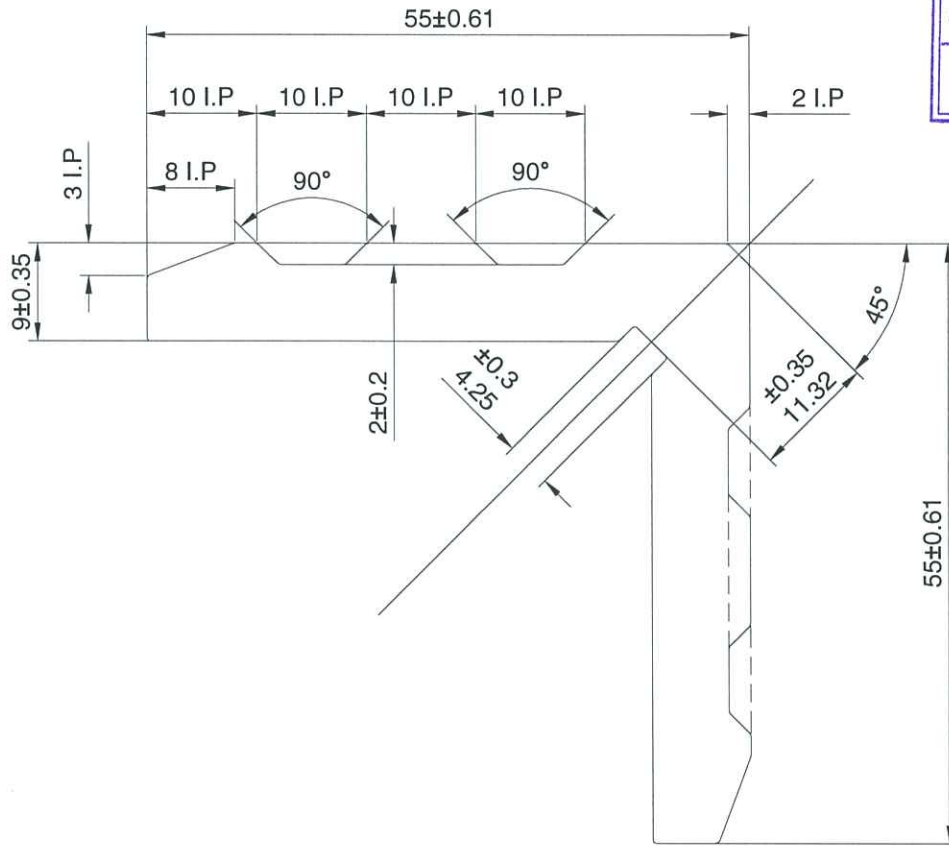

备注：没有配合型号！

NO. V. F
SCALE 1:1

AREA (SQ MM)	814.48	UNSPECIFIED THICKNESS	-	PERIMETER (MM)	222.15	STANDARD	BS EN755	SCALE	1.5:1
MASS (KG/M)	2.207	UNSPECIFIED CORNERS	R 0.3	SURFACE AREA	-	ALLOY	6063-T5	VERSION	-
COMPANY ISSUE	-	DRAWN	黄瓊玉	DATE	2023-05-19	APELLATION	-	PAGE	OF
		STANDARDIZATION		DATE					
		TO SIGN		DATE					
		AUDITING		DATE					
MARKER	MODIFY FILE NO	SIGNATURE	DATE	APPROV	DATE				

 美特鋁質有限公司
MIDI Aluminium Fabricator Ltd.

CUSTOMER	HONGKONG CO.	CUSTOMER APPROVAL	CUST PART NO.	X86467
			SECTION NO.	

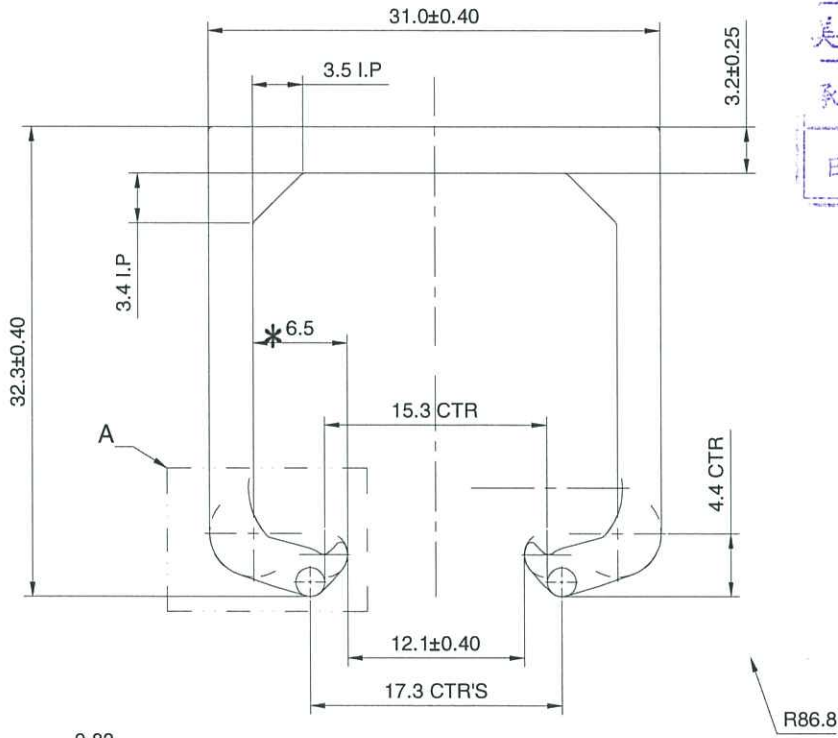

美特鋁質有限公司
承認圖面
日期 25.5.2023

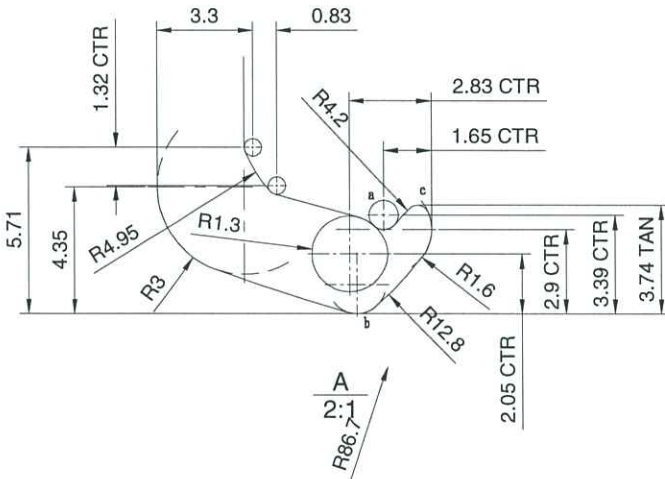

*重要尺寸!

a=R0.5 b=R1 c=R0.4

----- 装饰面

备注: 没有配合型号!

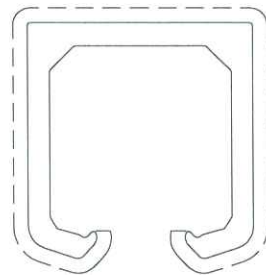

V.F

SCALE 1:1

AREA (SQ MM)	312.25	UNSPECIFIED THICKNESS	3±0.25	PERIMETER (MM)	197.03	STANDARD	BS EN755	SCALE	2:1
MASS (KG/M)	0.846	UNSPECIFIED CORNERS	R 0.3	SURFACE AREA	115.10	ALLOY	6063-T6	VERSION	-
COMPANY ISSUE	-	DRAWN	黃瓊玉	DATE	2023-05-19	APELLATION	-	PAGE	OF
		STANDARDIZATION		DATE					
		TO SIGN		DATE					
		AUDITING		DATE					
MARKER	MODIFY FILE NO	SIGNATURE	DATE	APPROV	DATE				

CUSTOMER	HONGKONG CO.	CUSTOMER APPROVAL		CUST PART NO.	X86468
				SECTION NO.	

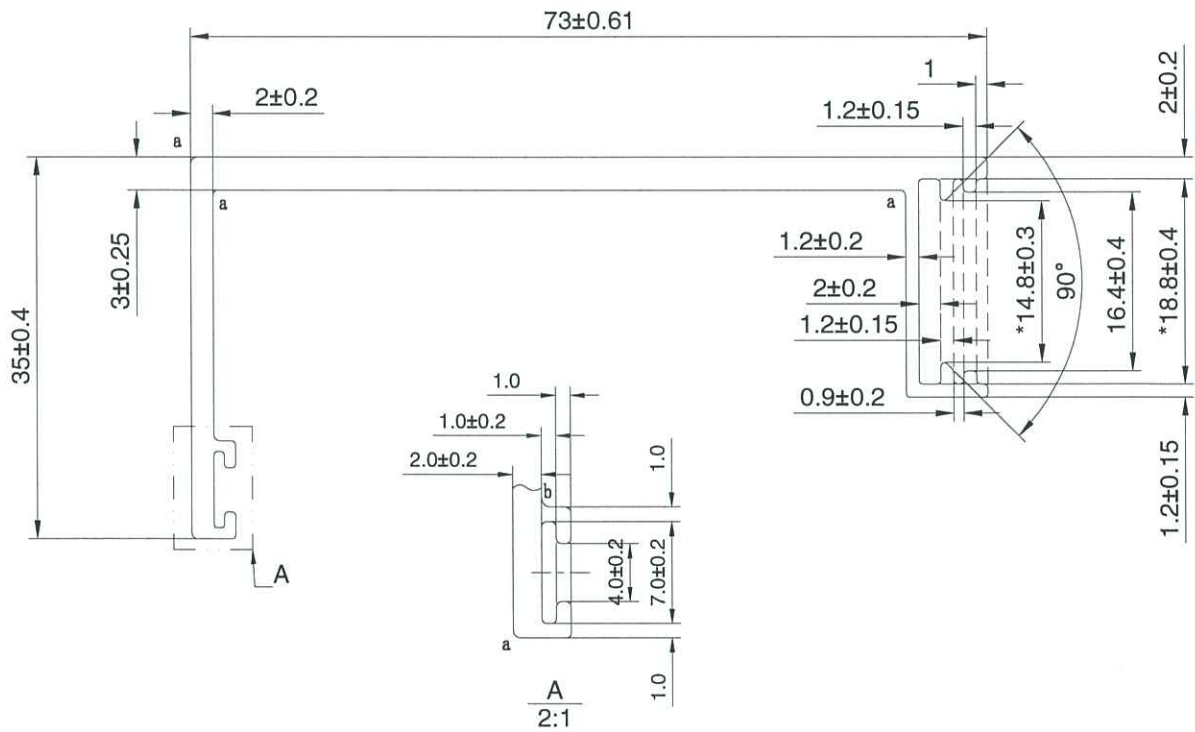
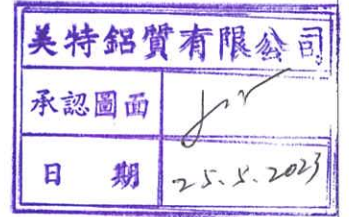

a=R0.5 b=R0.6

- 次要装饰面, 喷涂膜厚不足, 但不露底
- - - 装饰面
- 凹槽位置可能有露底现象, 即膜厚不足

*配合尺寸以实物配合效果为准!

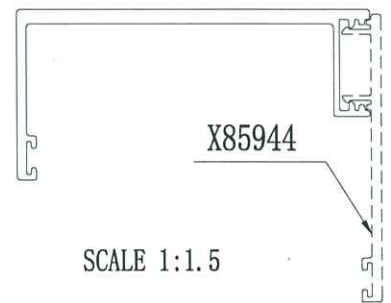
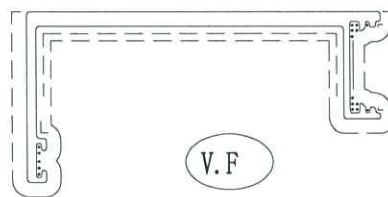

AREA (SQ MM)	321.15	UNSPECIFIED THICKNESS	-	PERIMETER (MM)	287.33	STANDARD	BS EN755	SCALE	1.5:1
MASS (KG/M)	0.870	UNSPECIFIED CORNERS	R 0.3	SURFACE AREA	215.13	ALLOY	6063-T6	VERSION	-
COMPANY ISSUE	-	DRAWN	黃瓊玉	DATE	2023-05-19	APELLATION	-	PAGE	OF
		STANDARDIZATION		DATE					
		TO SIGN		DATE					
		AUDITING		DATE					
MARKER	MODIFY FILE NO	SIGNATURE	DATE	APPROV	DATE				



CUSTOMER	HONGKONG CO.	CUSTOMER APPROVAL		CUST PART NO.	X86469
				SECTION NO.	

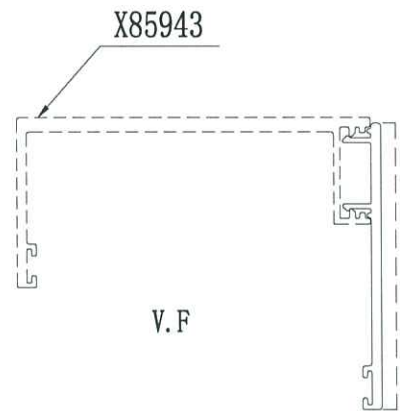
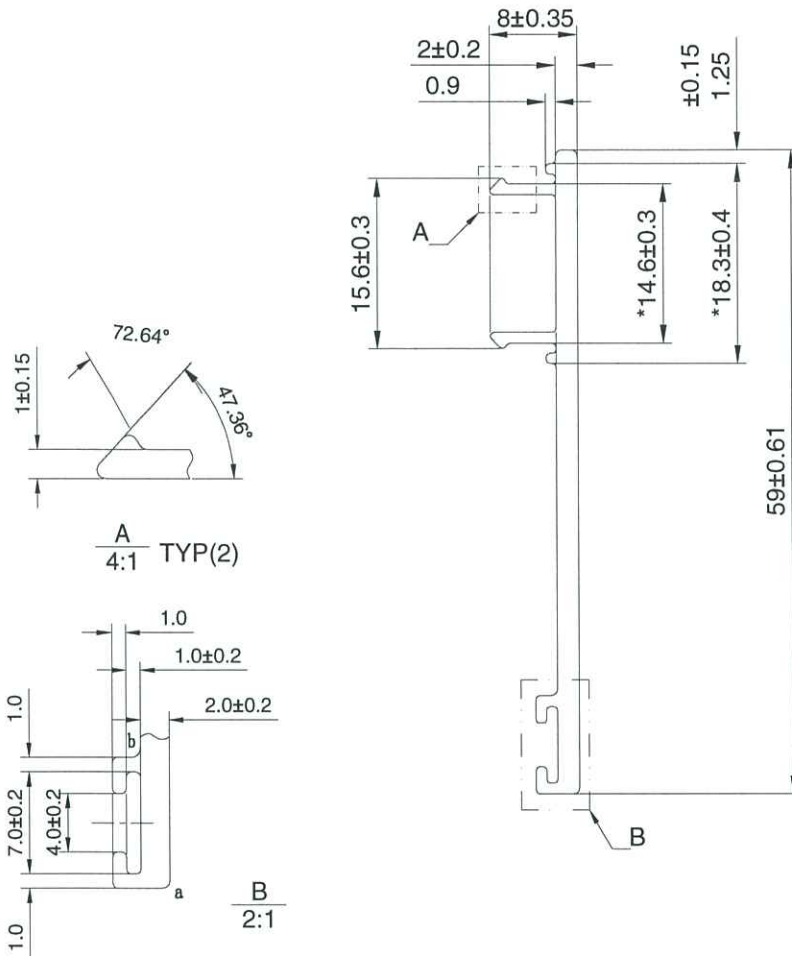
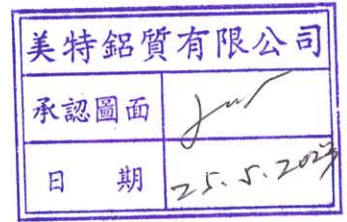

SCALE 1:1.5

a=R0.5 b=R0.6

*配合尺寸以实物配合效果为准!

AREA (SQ MM)	138.99	UNSPECIFIED THICKNESS	-	PERIMETER (MM)	159.79	STANDARD	BS EN755	SCALE	1.5:1
MASS (KG/M)	0.377	UNSPECIFIED CORNERS	R 0.3	SURFACE AREA	59.57	ALLOY	6063-T6	VERSION	-
COMPANY ISSUE		-	DRAWN	黃瓊玉	DATE	2023-05-19	APELLATION	-	PAGE OF
			STANDARDIZATION		DATE				
			TO SIGN		DATE				
			AUDITING		DATE				
MARKER	MODIFY	FILE NO	SIGNATURE	DATE	APPROV	DATE			



CUSTOMER	HONGKONG CO.	CUSTOMER APPROVAL	CUST PART NO.	X86470
			SECTION NO.	

美特鋁質有限公司	
承認圖面	<i>[Signature]</i>
日期	25.5.2023

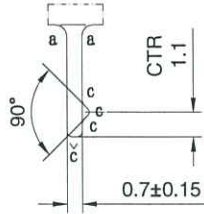
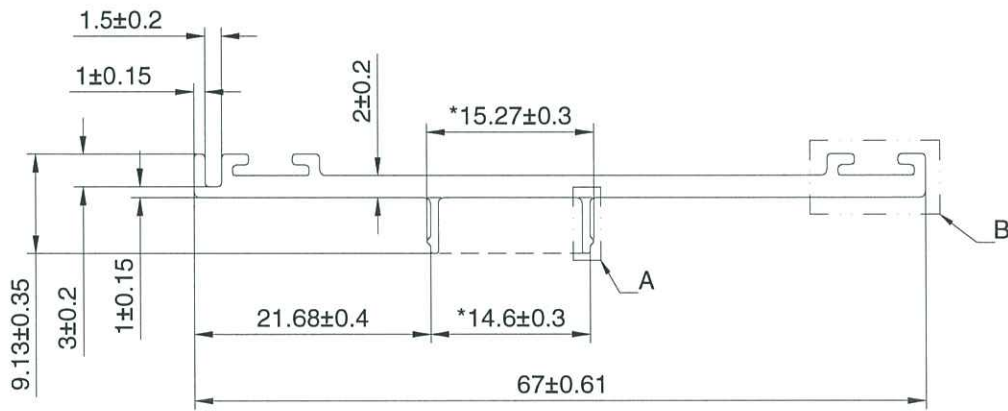

A
3:1 TYP(2)

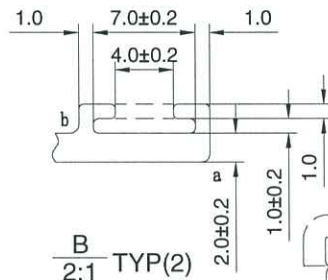

B
2:1 TYP(2)

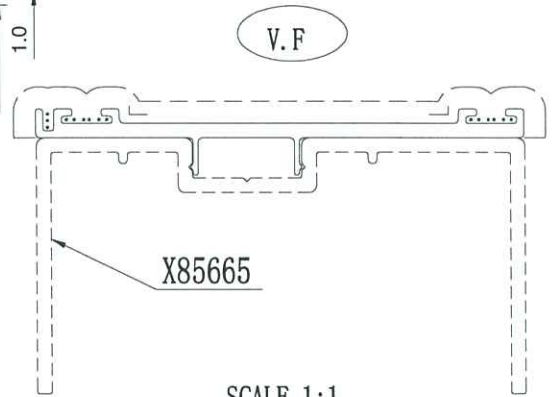

a=R0.5 b=R0.6 c=R0.2

==== 次要裝飾面, 噴塗膜厚不足, 但不露底

----- 裝飾面

●●●●● 凹槽位置可能會有露底現象, 即膜厚不足

*配合尺寸以实物配合效果为准!

AREA (SQ MM)	156.16	UNSPECIFIED THICKNESS	-	PERIMETER (MM)	187.76	STANDARD	BS EN755	SCALE	1.5:1
MASS (KG/M)	0.423	UNSPECIFIED CORNERS	R 0.3	SURFACE AREA	101.97	ALLOY	6063-T6	VERSION	-
COMPANY ISSUE	-	DRAWN	黃瓊玉	DATE	2023-05-19	APELLATION	-	PAGE	OF
		STANDARDIZATION		DATE					
		TO SIGN		DATE					
		AUDITING		DATE					
MARKER	MODIFY FILE NO	SIGNATURE	DATE	APPROV	DATE				

美特鋁質有限公司
MIDI Aluminium Fabricator Ltd.

CUSTOMER	HONGKONG CO.	CUSTOMER APPROVAL		CUST PART NO.	X86471
				SECTION NO.	

美特鋁質有限公司	
承認圖面	
日期	25.5.2023

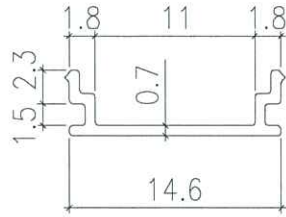

V.F

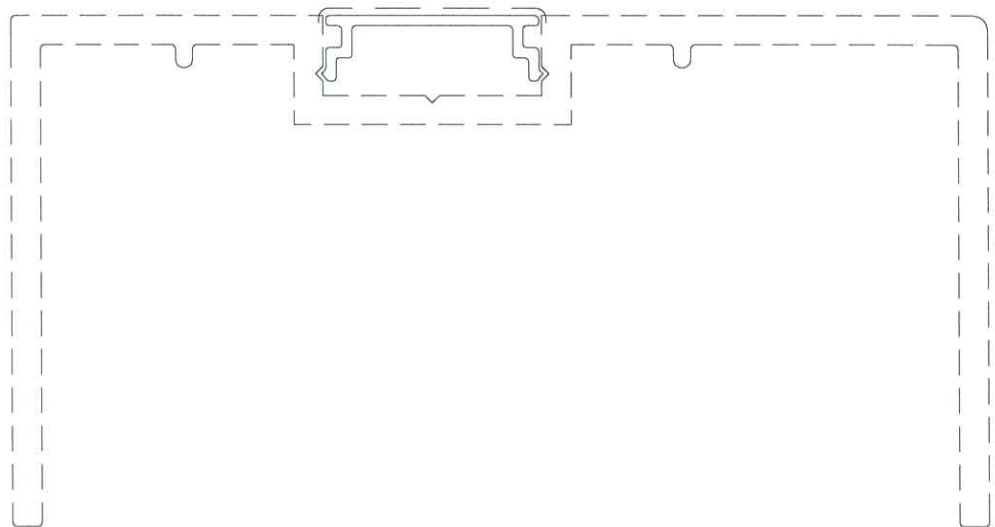

AREA (SQ MM)	17.23	UNSPECIFIED THICKNESS	-	PERIMETER (MM)	48.95	STANDARD	BS EN755	SCALE	-
MASS (KG/M)	0.047	UNSPECIFIED CORNERS	R 0.3	SURFACE AREA	17	ALLOY	6063-T6	VERSION	-
COMPANY ISSUE	-	DRAWN	黃瓊玉	DATE	2023-05-19	APELLATION	-	PAGE	OF
		STANDARDIZATION		DATE		 美特鋁質有限公司 MIDI Aluminium Fabricator Ltd.			
		TO SIGN		DATE					
		AUDITING		DATE					
MARKER	MODIFY FILE NO	SIGNATURE	DATE	APPROV	DATE				