

工程指示 / 要求簡箋 ENGINEER INSTRUCTIONS(E.I.)

工程指示編號:	EI- 5242	修改版本:	-
	HK-		
工程編號:	J 856	工程名稱:	TSWTL23
收件人:	Maggie	發件人:	BearLam
工程項目:	TSWTL23 工地窗模具	日期:	24/10/2022

<input type="checkbox"/> 原合約工程包	<input type="checkbox"/> 原合約工程加 / 減賬 QT-	<input type="checkbox"/> 新工程報價 QT-
---------------------------------	--	------------------------------------

信件批核號碼/圖紙參考編號:	批核模具圖紙編號:
客戶指示附件:	管理內部批簽署:

<input type="checkbox"/> 初步鋁料 B.M.	<input type="checkbox"/> 加工拆圖, 然後生產	<input type="checkbox"/> 尺寸表
<input type="checkbox"/> 正式鋁料 B.M.	<input type="checkbox"/> 技術上資料 / 指示	<input type="checkbox"/> 報價
<input type="checkbox"/> 配件 B.M.	<input type="checkbox"/> 樣辦或貨品說明書	<input type="checkbox"/> 分判合約
<input type="checkbox"/> 其他:		

內容: 請根據附件內容堅美開新模具, 合共10個新模具 X86381 ~ X86391
完成上列要求日期: 31/10/2022

國內

<input type="checkbox"/> 生產技術總監	<input type="checkbox"/> 連附件	<input type="checkbox"/> 技術部	<input type="checkbox"/> 連附件	<input type="checkbox"/> 生產部	<input type="checkbox"/> 連附件
<input type="checkbox"/> 採購部	<input type="checkbox"/> 連附件	<input type="checkbox"/> 生產統籌部	<input type="checkbox"/> 連附件	<input type="checkbox"/> 報關組	<input type="checkbox"/> 連附件
<input type="checkbox"/> 質檢部	<input type="checkbox"/> 連附件	<input type="checkbox"/> 會計部	<input type="checkbox"/> 連附件	<input type="checkbox"/> 機械設計部	<input type="checkbox"/> 連附件
<input type="checkbox"/> 香港辦	<input type="checkbox"/> 連附件	<input type="checkbox"/> 其他:			

香港

<input type="checkbox"/> 行政部	<input type="checkbox"/> 連附件	<input type="checkbox"/> 會計部	<input type="checkbox"/> 連附件	<input type="checkbox"/> 統籌部	<input type="checkbox"/> 連附件	<input type="checkbox"/> 工程組	<input type="checkbox"/> 連附件
<input checked="" type="checkbox"/> 採購部	<input checked="" type="checkbox"/> 連附件	<input type="checkbox"/> QS部	<input type="checkbox"/> 連附件	<input type="checkbox"/> 地盤管理	<input type="checkbox"/> 連附件	<input type="checkbox"/> 維修部	<input type="checkbox"/> 連附件

*發件人簽署:	<i>Bear Lam</i>	*組別成員批核簽署:	<i>[Signature]</i> 24/10/2022
傳遞編號:		項目經理簽署:	<i>[Signature]</i>

CUSTOMER	CUSTOMER APPROVAL	CUST PART NO.	IW-01
		SECTION NO.	X86381

美特鋁質有限公司  
承認圖面  
日期 24/10/2022

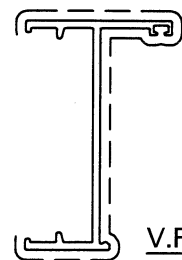
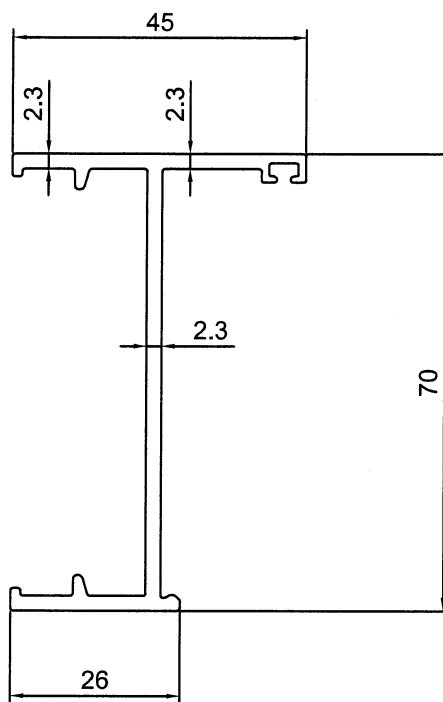
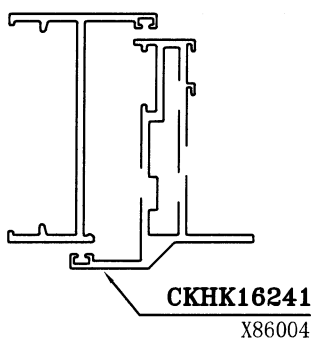

SCALE 1:2

SIGNATURE GRADEING	HIGH SIGNATURE GRADEING	C.C.DIA(MM)							
AREA (SQ MM)		UNSPECIFIED THICKNESS	2.3	PERIMETER (MM)		STANDARD		SCALE	1:1
MASS (KG/M)		UNSPECIFIED CORNERS	-	SURFACE AREA		ALLOY	6063-T5	VERSION	
COMPANY ISSUE			DRAWN	L	DATE	2022-10-21	APPELLATION	PAGE OF	
			STANDARDIZATION		DATE				
			TO SIGN		DATE				
			AUDITING		DATE				
MARKER	MODIFY	FILE NO	SIGNATURE	DATE	APPROV				

美特鋁質有限公司  
MIDI Aluminium Fabricator Ltd.

CUSTOMER	CUSTOMER APPROVAL	CUST PART NO.	IW-06
		SECTION NO.	X86382

美特鋁質有限公司	
承認圖面	<i>Jai</i>
日期	24/10/2023

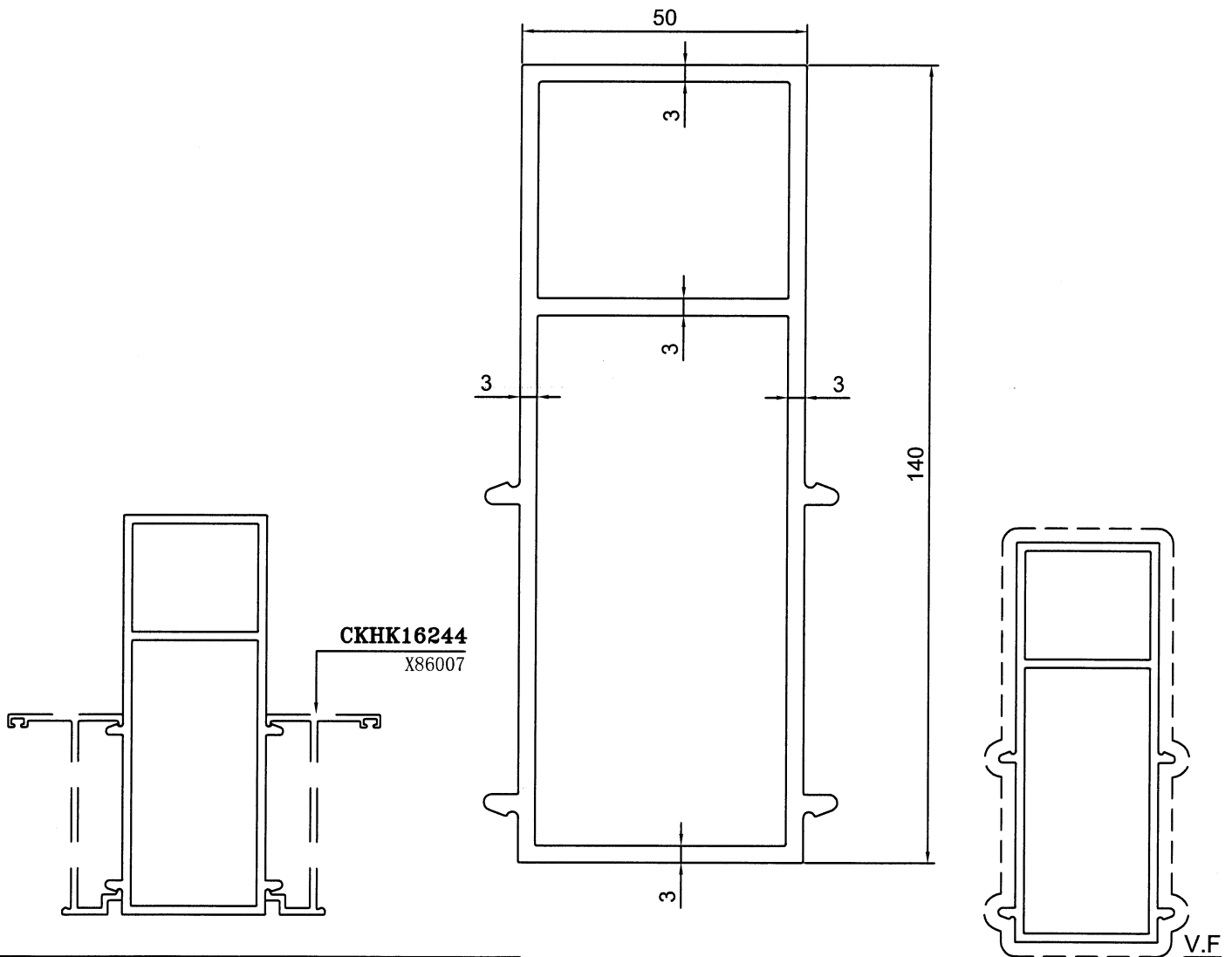

SIGNATURE GRADEING	HIGH SIGNATURE GRADEING	C.C.DIA(MM)							
AREA (SQ MM)		UNSPECIFIED THICKNESS	3	PERIMETER (MM)		STANDARD		SCALE	1:1
MASS (KG/M)		UNSPECIFIED CORNERS	-	SURFACE AREA		ALLOY	6063-T5	VERSION	
COMPANY ISSUE			DRAWN	L	DATE	2022-10-21	APPELLATION		PAGE OF
			STANDARDIZATION		DATE				
			TO SIGN		DATE				
			AUDITING		DATE				
MARKER	MODIFY	FILE NO	SIGNATURE	DATE	APPROV				

**美特鋁質有限公司**  
 MIDI Aluminium Fabricator Ltd.

CUSTOMER	CUSTOMER APPROVAL	CUST PART NO.	IW-12
		SECTION NO.	X86383

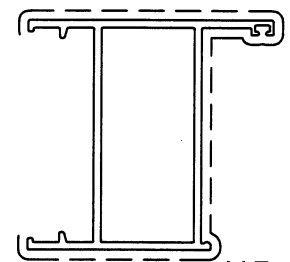
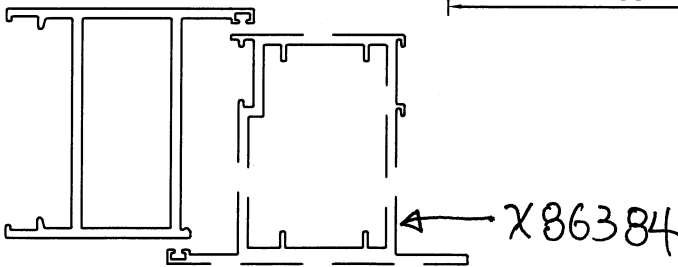
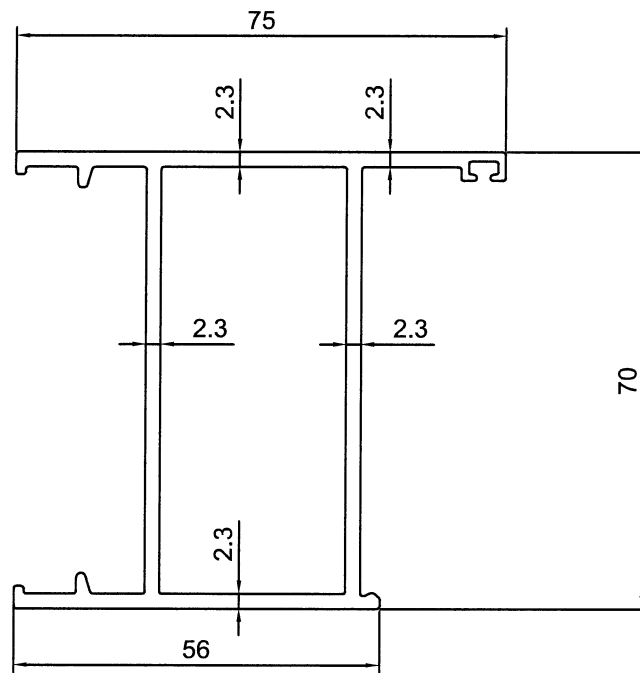
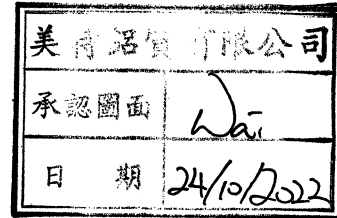

SCALE 1:2

SIGNATURE GRADEING	HIGH SIGNATURE GRADEING	C.C.DIA(MM)							
AREA (SQ MM)		UNSPECIFIED THICKNESS	2.3	PERIMETER (MM)		STANDARD		SCALE	1:1
MASS (KG/M)		UNSPECIFIED CORNERS	-	SURFACE AREA		ALLOY	6063-T5	VERSION	
COMPANY ISSUE			DRAWN	L	DATE	2022-10-21	APPELLATION	PAGE OF	
			STANDARDIZATION		DATE				
			TO SIGN		DATE				
			AUDITING		DATE				
MARKER	MODIFY FILE NO	SIGNATURE	DATE	APPROV		DATE			

CUSTOMER	CUSTOMER APPROVAL	CUST PART NO.	IW-13
		SECTION NO.	X86384

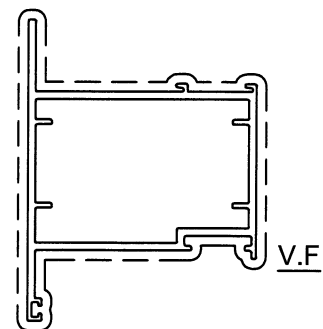
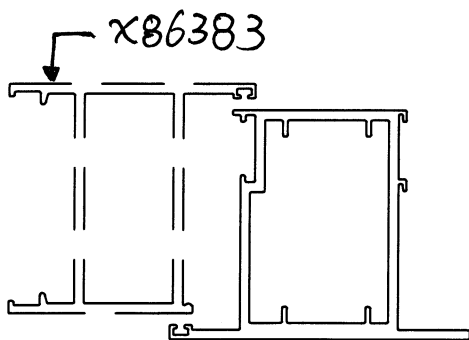
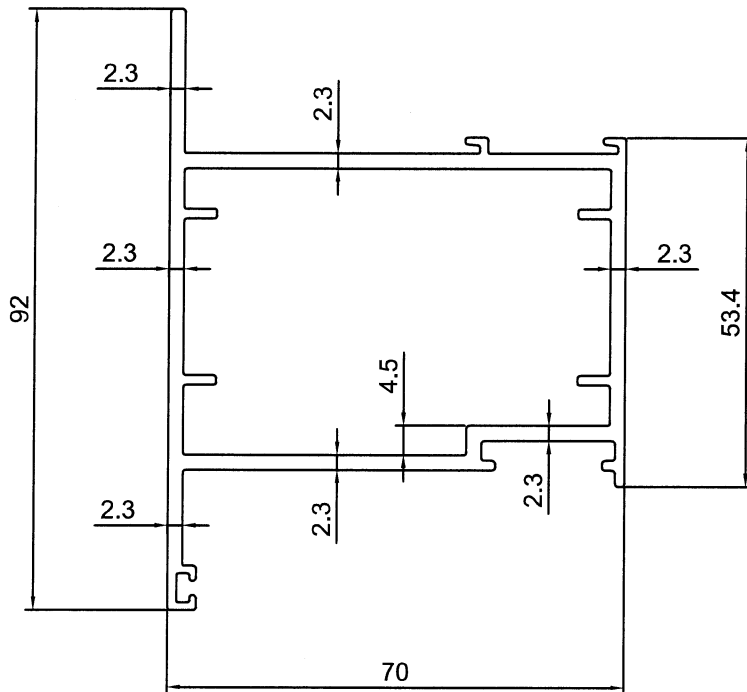
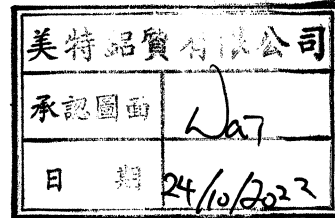

SCALE 1:2

SIGNATURE GRADEING	HIGH SIGNATURE GRADEING	C.C.DIA(MM)							
AREA (SQ MM)		UNSPECIFIED THICKNESS	2.3	PERIMETER (MM)		STANDARD		SCALE	1:1
MASS (KG/M)		UNSPECIFIED CORNERS	-	SURFACE AREA		ALLOY	6063-T5	VERSION	
COMPANY ISSUE			DRAWN	L	DATE	2022-10-21	APPELLATION	PAGE OF	
			STANDARDIZATION		DATE				
			TO SIGN		DATE				
			AUDITING		DATE				
MARKER	MODIFY	FILE NO	SIGNATURE	DATE	APPROV				

CUSTOMER	CUSTOMER APPROVAL	CUST PART NO.	IW-23
		SECTION NO.	X86385

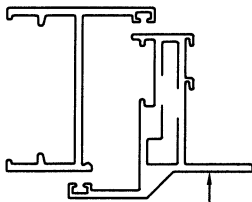
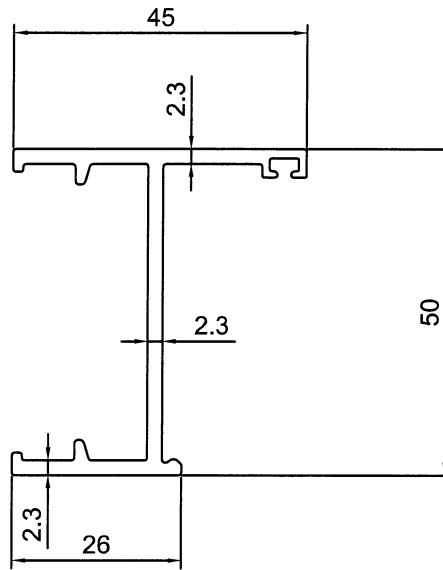
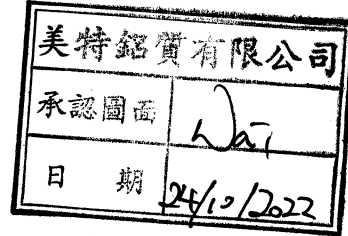

CKHK16248  
X86011

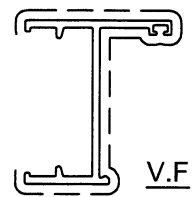

SCALE 1:2

SIGNATURE GRADEING	HIGH SIGNATURE GRADEING	C.C.DIA(MM)							
AREA (SQ MM)		UNSPECIFIED THICKNESS	2.3	PERIMETER (MM)		STANDARD		SCALE	1:1
MASS (KG/M)		UNSPECIFIED CORNERS	-	SURFACE AREA		ALLOY	6063-T5	VERSION	
COMPANY ISSUE			DRAWN	L	DATE	2022-10-21	APPELLATION	PAGE OF	
			STANDARDIZATION		DATE				
			TO SIGN		DATE				
			AUDITING		DATE				
MARKER	MODIFY FILE NO	SIGNATURE	DATE	APPROV		DATE			

CUSTOMER	CUSTOMER APPROVAL	CUST PART NO.	IW-26
		SECTION NO.	X86367

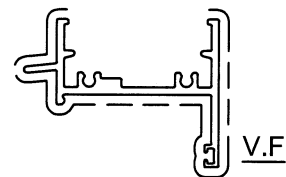
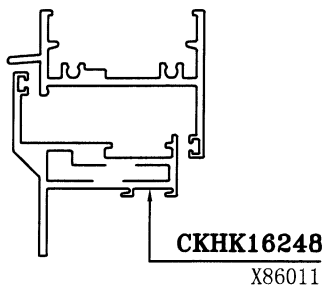
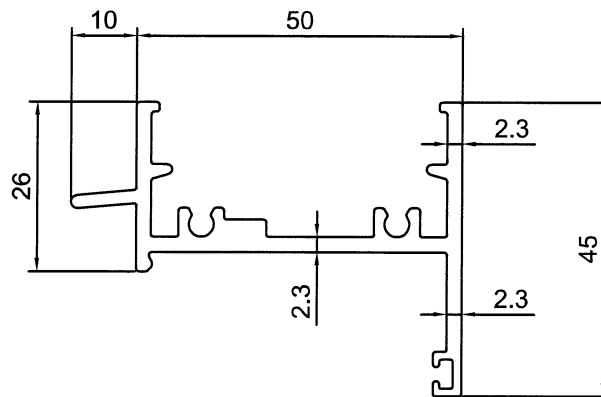
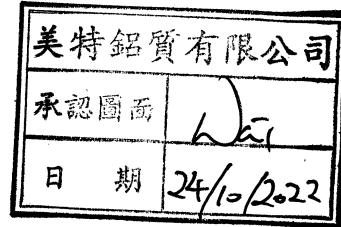

SCALE 1:2

SIGNATURE GRADEING	HIGH SIGNATURE GRADEING	C.C.DIA(MM)							
AREA (SQ MM)		UNSPECIFIED THICKNESS	2.3	PERIMETER (MM)		STANDARD		SCALE	1:1
MASS (KG/M)		UNSPECIFIED CORNERS	-	SURFACE AREA		ALLOY	6063-T6	VERSION	
COMPANY ISSUE			DRAWN	L	DATE	2022-10-21	APELLATION		PAGE OF
			STANDARDIZATION		DATE				
			TO SIGN		DATE				
			AUDITING		DATE				
MARKER	MODIFY	FILE NO	SIGNATURE	DATE	APPROV				

CUSTOMER	CUSTOMER APPROVAL	CUST PART NO.	IW-07
		SECTION NO.	X86388

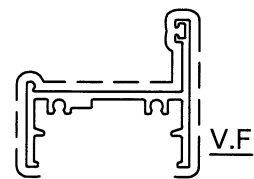
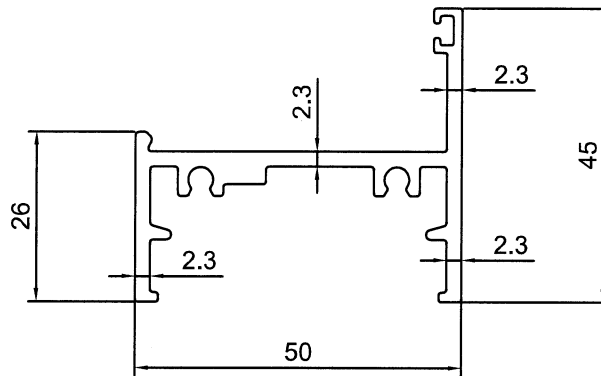
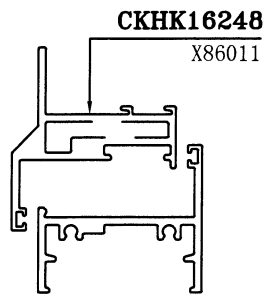
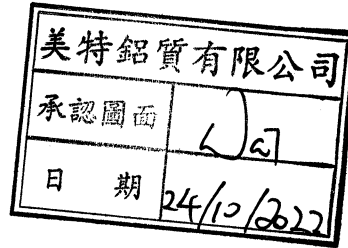

SCALE 1:2

SIGNATURE GRADEING	HIGH SIGNATURE GRADEING	C.C.DIA(MM)							
AREA (SQ MM)		UNSPECIFIED THICKNESS	2.3	PERIMETER (MM)		STANDARD		SCALE	1:1
MASS (KG/M)		UNSPECIFIED CORNERS	-	SURFACE AREA		ALLOY	6063-T6	VERSION	
COMPANY ISSUE			DRAWN	L	DATE	2022-10-21	APPELLATION		PAGE OF
			STANDARDIZATION		DATE				
			TO SIGN		DATE				
			AUDITING		DATE				
MARKER	MODIFY	FILE NO	SIGNATURE	DATE	APPROV				

CUSTOMER	CUSTOMER APPROVAL	CUST PART NO.	IW-05
		SECTION NO.	X86389

美特鋁質有限公司  
承認圖面  
日期 24/10/2022

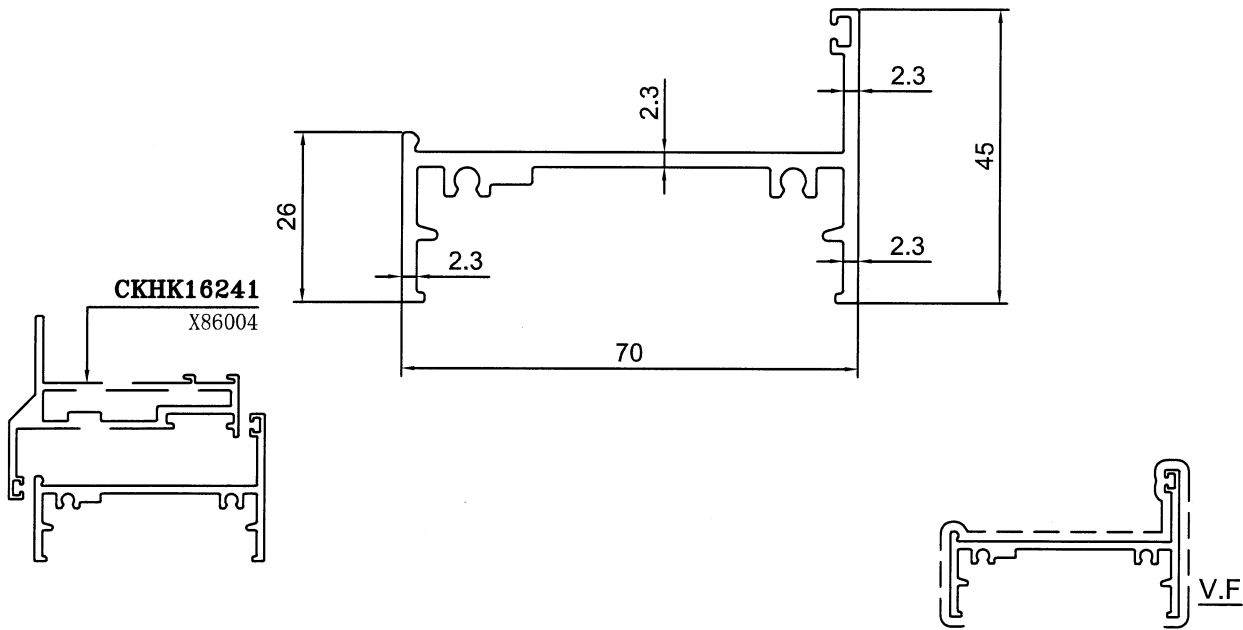

SCALE 1:2

SIGNATURE GRADEING	HIGH SIGNATURE GRADEING	C.C.DIA(MM)							
AREA (SQ MM)		UNSPECIFIED THICKNESS	2.3	PERIMETER (MM)		STANDARD		SCALE	1:1
MASS (KG/M)		UNSPECIFIED CORNERS	-	SURFACE AREA		ALLOY	6063-T6	VERSION	
COMPANY ISSUE			DRAWA	L	DATE	2022-10-21	APELLATION	PAGE OF	
			STANDA- RDIZATION		DATE				
			TO SIGN		DATE				
			AUDITING		DATE				
MARKER	MODIFY FILE NO	SIGNATURE	DATE	APPROV		DATE			

美特鋁質有限公司  
MIDI Aluminium Fabricator Ltd.

CUSTOMER	CUSTOMER APPROVAL	CUST PART NO.	IW-07
		SECTION NO.	X86390

美特鋁質有限公司  
承認圖章  
日期 24/10/2024

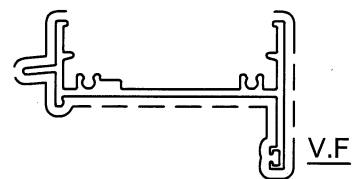
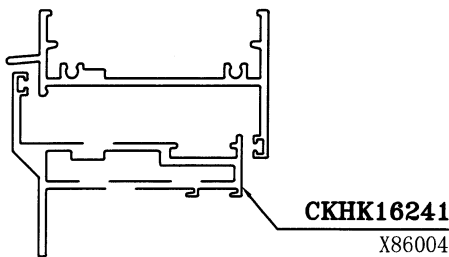
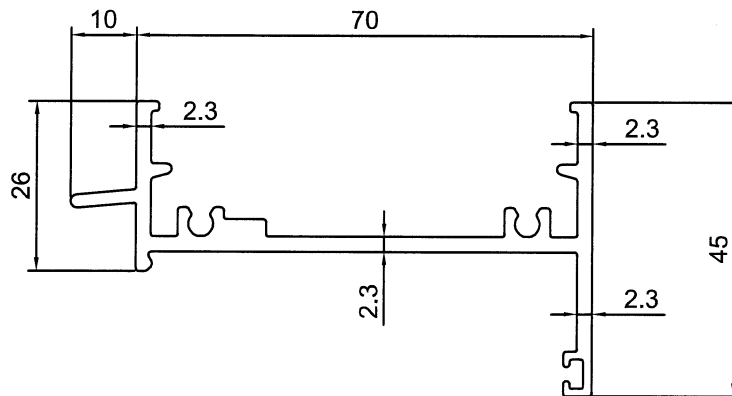

SCALE 1:2

SIGNATURE GRADEING	HIGH SIGNATURE GRADEING	C.C.DIA(MM)							
AREA (SQ MM)		UNSPECIFIED THICKNESS	2.3	PERIMETER (MM)		STANDARD		SCALE	1:1
MASS (KG/M)		UNSPECIFIED CORNERS	-	SURFACE AREA		ALLOY	6063-T6	VERSION	
COMPANY ISSUE			DRAWN	L	DATE	2022-10-21	APPELLATION	PAGE OF	
			STANDARDIZATION		DATE				
			TO SIGN		DATE				
			AUDITING		DATE				
MARKER	MODIFY	FILE NO	SIGNATURE	DATE	APPROV		DATE		

美特鋁質有限公司  
MIDI Aluminium Fabricator Ltd.

CUSTOMER	CUSTOMER APPROVAL	CUST PART NO.	IW-10
		SECTION NO.	X86391

美特鋁質有限公司  
承認圖面  
日期 24/10/2022

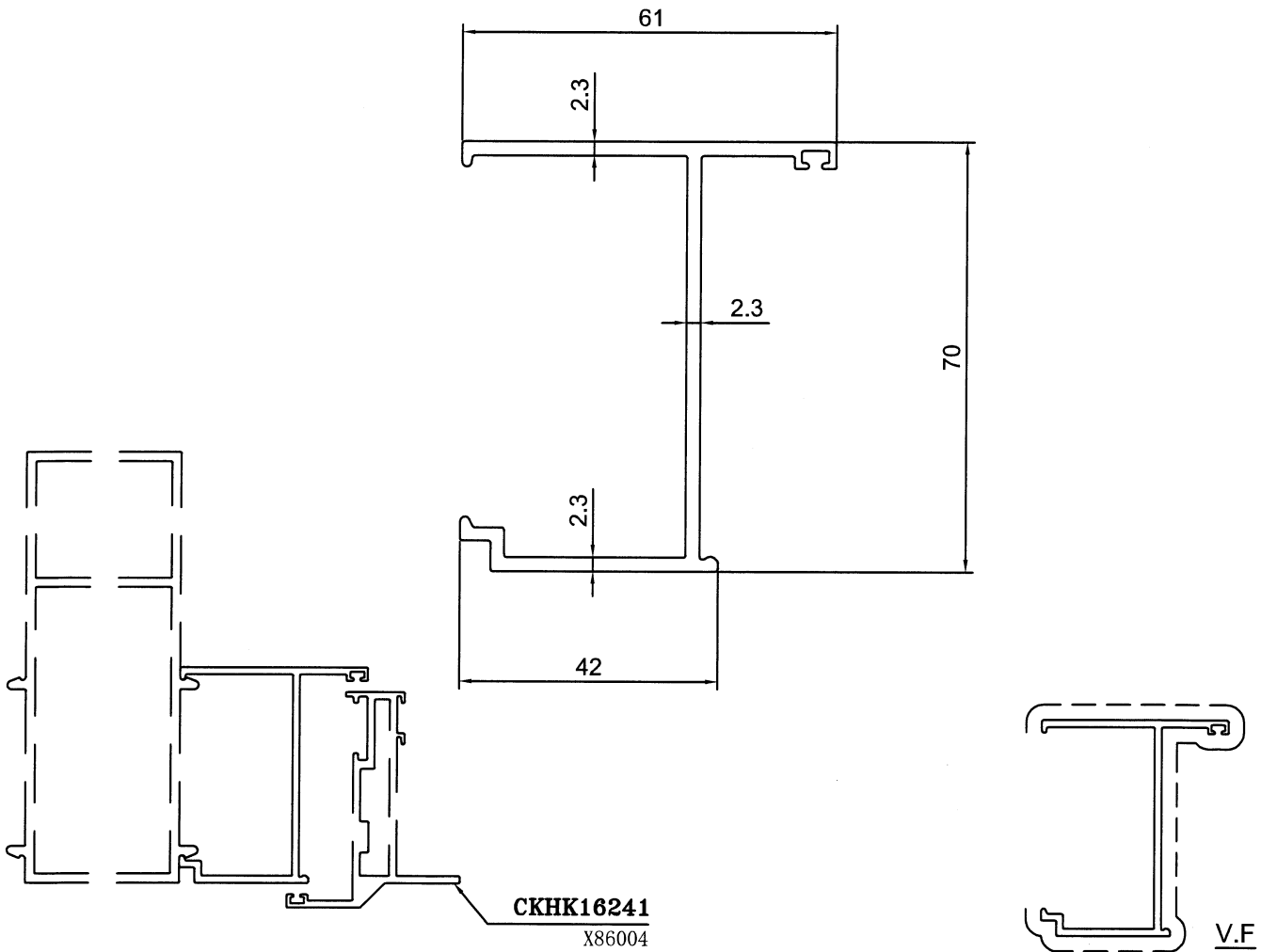

SIGNATURE GRADEING	HIGH SIGNATURE GRADEING	C.C.DIA(MM)							
AREA (SQ MM)		UNSPECIFIED THICKNESS	2.3	PERIMETER (MM)		STANDARD		SCALE	1:1
MASS (KG/M)		UNSPECIFIED CORNERS	-	SURFACE AREA		ALLOY	6063-T5	VERSION	
COMPANY ISSUE			DRAWN	L	DATE	2022-10-21		APELLATION	PAGE OF
			STANDARDIZATION		DATE				
			TO SIGN		DATE				
			AUDITING		DATE				
MARKER	MODIFY	FILE NO	SIGNATURE	DATE	APPROV		DATE		

美特鋁質有限公司  
MIDI Aluminium Fabricator Ltd.