



工程指示 / 要求簡箋 ENGINEER INSTRUCTIONS(E.I.)

工程指示編號:	EI- 5122C	修改版本:	C
	HK-2088		
工程編號:	J 856	工程名稱:	天榮站
收件人:	生統/技術部	發件人:	Lai Sik Hung
工程項目:	佛沙窗 Shop Drawing (修訂C:16th Submission)	日期:	24/11/2022

<input type="checkbox"/> 原合約工程包	<input type="checkbox"/> 原合約工程加 / 減賬 QT-	<input type="checkbox"/> 新工程報價 QT-
---------------------------------	--	------------------------------------

信件批核號碼/圖紙參考編號:	批核模具圖紙編號:
客戶指示附件:	管理內部批簽署:

<input type="checkbox"/> 初步鋁料 B.M.	<input type="checkbox"/> 加工拆圖, 然後生產	<input type="checkbox"/> 尺寸表
<input type="checkbox"/> 正式鋁料 B.M.	<input type="checkbox"/> 技術上資料/指示	<input type="checkbox"/> 報價
<input type="checkbox"/> 配件 B.M.	<input type="checkbox"/> 樣辦或貨品說明書	<input type="checkbox"/> 分判合約
<input type="checkbox"/> 其他:		

內容: 佛沙窗 Shop Drawing (修訂C:16th Submission)
完成上列要求日期: ASAP

國內

<input type="checkbox"/> 生產技術總監	<input type="checkbox"/> 連附件	<input checked="" type="checkbox"/> 技術部	<input checked="" type="checkbox"/> 連附件	<input type="checkbox"/> 生產部	<input type="checkbox"/> 連附件
<input type="checkbox"/> 採購部	<input type="checkbox"/> 連附件	<input checked="" type="checkbox"/> 生產統籌部	<input checked="" type="checkbox"/> 連附件	<input type="checkbox"/> 報關組	<input type="checkbox"/> 連附件
<input type="checkbox"/> 質檢部	<input type="checkbox"/> 連附件	<input type="checkbox"/> 會計部	<input type="checkbox"/> 連附件	<input type="checkbox"/> 機械設計部	<input type="checkbox"/> 連附件
<input checked="" type="checkbox"/> 香港辦	<input checked="" type="checkbox"/> 連附件	<input type="checkbox"/> 其他:			

<input type="checkbox"/> 行政部	<input type="checkbox"/> 連附件	<input type="checkbox"/> 會計部	<input type="checkbox"/> 連附件	<input type="checkbox"/> 統籌部	<input type="checkbox"/> 連附件	<input type="checkbox"/> 工程部	<input type="checkbox"/> 連附件
<input type="checkbox"/> 採購部	<input type="checkbox"/> 連附件	<input type="checkbox"/> QS部	<input type="checkbox"/> 連附件	<input type="checkbox"/> 地盤管理	<input type="checkbox"/> 連附件	<input type="checkbox"/> 維修部	<input type="checkbox"/> 連附件

*發件人簽署:		*組別成員批核簽署:	
傳遞編號:		項目經理簽署:	

PROJECT :

**PROPOSED DEVELOPMENT ABOVE
LIGHT RAIL TIN WING STOP, TSWTL
NO.23, AREA 33, TIN SHUI WAI, N.T.**

16

SHOP DRAWING FOR ALUM. PRECAST WINDOW OF TOWER

DATE: 26-Oct-22

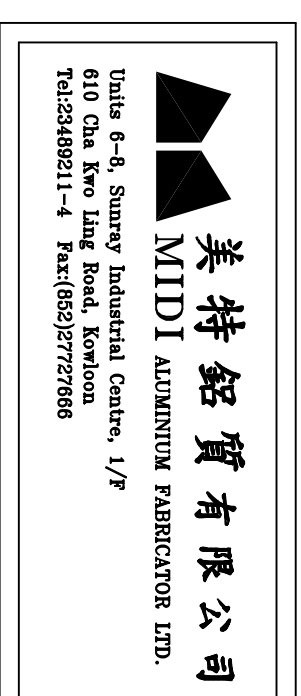

GENERAL NOTES FOR PRECAST ALUM. WINDOW PAGE 1

CODES AND STANDARDS

1. CODE OF PRACTICE ON WIND EFFECTS IN HONG KONG 2004.
2. CODE OF PRACTICE FOR DEAD AND IMPOSED LOADS 2011.
3. CODE OF PRACTICE FOR STRUCTURAL USE OF CONCRETE 2011.
4. CODE OF PRACTICE FOR THE STRUCTURAL USE OF STEEL 2011.
5. CODE OF PRACTICE FOR STRUCTURAL USE OF GLASS 2018.
6. STRUCTURAL USE OF ALUMINIUM, BS 8118-1:1991. (WIND LOAD FACTOR OF 1.4 FOR ALUMINIUM DESIGN TO PNP APP3)
7. BUILDING (CONSTRUCTION) REGULATIONS CAP 123.
8. APP37 CURTAIN WALL, WINDOW AND WINDOW WALL SYSTEM.
9. APP110 PROTECTIVE BARRIERS.
10. APP118 ALUMINIUM WINDOWS.

DESIGN WIND LOAD

CODE OF PRACTICE ON WIND EFFECTS IN HONG KONG 2004.

HEIGHT ABOVE GROUND LEVEL
 VERTICAL SURFACE
 <148.3m
 BASIC WIND PRESSURE
 3.04kPa
 TOPOGRAPHY FACTOR (Sp)
 1.00
 PRESSURE COEFFICIENT (Cp)
 +1.0/-1.4
 DESIGN WIND PRESSURE
 +3.04/-4.261kPa

IMPOSED LOAD ON PROTECTIVE BARRIERS (FOR DOMESTIC USE)

CATEGORY	LINE LOAD TO BE APPLIED AT A HEIGHT OF 1.1m ABOVE THE FLOOR LEVEL (kN/m)	UNIFORMLY DISTRIBUTED LOAD TO BE APPLIED ON THE INFILL BETWEEN FLOOR AND TOP RAIL (kPa)	CONCENTRATED LOAD TO BE APPLIED ON ANY PART OF THE INFILL BETWEEN FLOOR AND TOP RAIL (kN)
AREAS WHERE CONCENTRATION OF PEOPLE IS NOT EXPECTED	0.75	1.0	0.5

STEEL

ALL STRUCTURAL STEEL SECTIONS SHALL BE GRADE S275 JO CLASS 1 WELDABLE STRUCTURAL STEEL AND COMPLYING WITH BS EN 10210 2006 FOR HOLLOW SECTION AND BS EN 10025 FOR OTHER SECTIONS.

ALL STRUCTURAL STEEL SHALL BE HOT-DIP GALVANIZED AND COMPLY WITH BS EN ISO 1461 WITH MIN 85 μm COATING THICKNESS.

ALL OUT/WELDED AREAS IN GALVANIZED STEEL SHALL BE MADE GOOD BY AT LEAST TWO COATS OF ZINC RICH PRIMER TO BS 4692.

DENSITY 77kN/m³
 YOUNG'S MODULUS 205,000kPa
 YIELD STRENGTH 275kPa
 MINIMUM TENSILE STRENGTH 430kPa
 DESIGN STRENGTH (S16mm) 275kPa
 DESIGN STRENGTH (S40mm) 265kPa

ALUMINIUM EXTRUSION

UNLESS OTHERWISE STATED, ALL ALUMINIUM EXTRUSIONS SHALL BE GRADE 6063-T6/6061-T6 AND COMPLY WITH BS EN 755-2 AND BS EN 573-3.

DENSITY 27.2kN/m³
 YOUNG'S MODULUS 70,000kPa
 0.2% PROOF STRESS 6063-T6 6061-T6
 MINIMUM TENSILE STRENGTH 160kPa 240kPa
 DESIGN TENSILE STRENGTH 215kPa 260kPa
 DESIGN SHEAR STRENGTH 311kPa 311kPa
 DESIGN BEARING STRENGTH 828kPa 828kPa
 LIMITING BENDING STRENGTH 160kPa 240kPa
 LIMITING TENSILE STRENGTH 175kPa 260kPa
 LIMITING SHEAR STRENGTH 95kPa 145kPa

FASTENERS/SCREWS

ALL STAINLESS STEEL SCREW AND BOLT SHALL BE GRADE 316 AND COMPLY WITH BS EN ISO 3506.

0.2% PROOF STRESS 450kPa
 MINIMUM TENSILE STRENGTH 700kPa
 DESIGN TENSILE STRENGTH 450kPa
 DESIGN SHEAR STRENGTH 311kPa
 DESIGN BEARING STRENGTH 828kPa

PROTECTION OF B-METALIC CORROSION (BITUMEN PAINT ETC.)

ALL EXPOSED SURFACE OF ALUM. EXTRUSION SHALL BE FINISHED WITH PTFE COATING 40 MICRONS
 ALL SCREWS SHALL BE M5 S5 SCREW SPACING @300/C MAX. UNLESS OTHERWISE STATED.

GLASS

ALL GLASS PANELS SHALL BE COMPLIED WITH BS 962 AND DESIGN TO CODE OF PRACTICE FOR STRUCTURAL USE OF GLASS 2018.
 IMPACT TEST TO BE COMPLIED WITH BS EN 12893 CLASS 1)

DENSITY 25kN/m³
 YOUNG'S MODULUS 70,000kPa

ULTIMATE DESIGN STRENGTH OF GLASS

HEAT STRENGTHENED GLASS(S) 80kPa
 TEMPERED GLASS(TP) 40kPa

ALL TEMPERED GLASS SHALL COMPLY WITH HEAT SOAK TEST REQUIREMENT IN ACCORDANCE WITH PNP APP 37-2022.
 HEAT SOAK PROCESS CONFORMING TO BS EN 14179-1: 2016 AND COMPLYING WITH CODE OF PRACTICE FOR STRUCTURAL USE OF GLASS 2018 SHOULD BE CARRIED OUT.

EG-1--6mmHS+12mm AR GP+10mmTP THK. I.G.U.

EG-1A--6mmHS+12mm AR GP+6mmTP THK. I.G.U.

EG-2--10mm THK. CLEAR TEMPERED GLASS

EG-4--10mm THK. TEMPERED ACID ETCHED GLASS

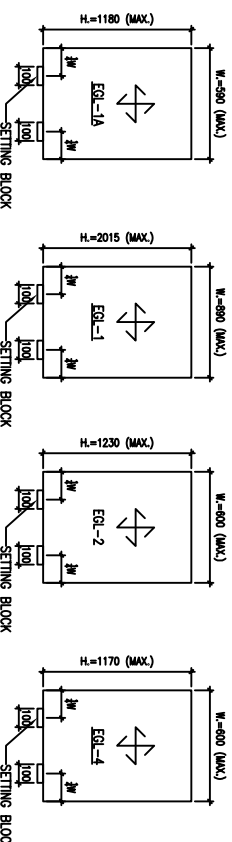

TYPICAL GLASS DETAIL

FOR DOUBLE GLAZING GLASS UNIT (IGU)

QUALITY ASSURANCE DOCUMENT SUCH AS TEST REPORT / CERTIFICATES INDICATING COMPLIES WITH ASTM E2190 OR EQUIVALENT WITH RESPECT TO THE SEAL PERFORMANCE.
 FOR INSTALLING GLASS UNIT SHALL BE SUBMITTED BEFORE COMMENCEMENT OF WORK.

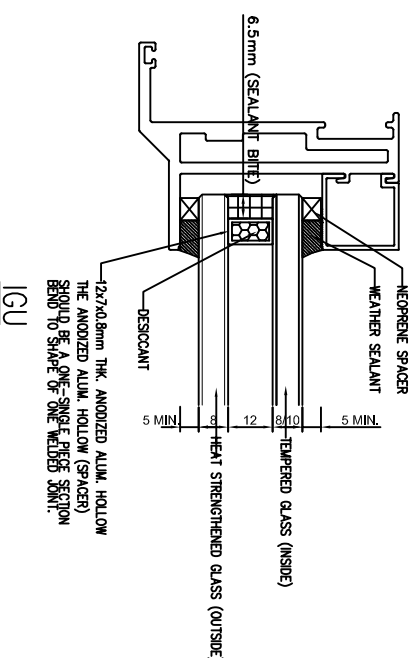

SEALANT, GASKET AND SETTING BLOCK

ALL STRUCTURAL SEALANT SHALL BE DOWSIL 983 (90-SS901), ALLOWABLE STRESS = 138kPa.

ALL WEATHER SEALANT SHALL BE DOWSIL 791.

ALL SETTING BLOCK SHALL BE SILICONE RUBBER WITH HARDNESS OF 85±5 SHORE A.

MINIMUM 100mm IN LENGTH AT 1/4 SPAN UNLESS OTHERWISE STATED

ALL GASKET SHALL BE NEOPRENE OR SILICONE RUBBER WHEN IN CONTACT WITH SEALANT, WITH HARDNESS OF 65±5 SHORE A.

ISOLATOR

PVC TAPE TO BE APPLIED BETWEEN DISSIMILAR METAL TO PREVENT GALVANIC CORROSION TO PPG484.

CONCRETE

ALL CONCRETE STRUCTURES SHOWN IN THIS SUBMISSION ARE FOR INFORMATION ONLY.

CONCRETE STRENGTH SHALL BE 45kPa. (MIN.)

WELDING

ALL WELDING TO BE COMPLIED WITH BS EN 1011-1.
 DESIGN WELD STRENGTH = 220 MPa

ALL WELDING PROCEDURES TO COMPLY WITH BS EN ISO 15614.

ALL WELD TO BE 5mm THICK FILLET WELD ALL AROUND UNLESS OTHERWISE STATED.
 ALL WELD SHALL BE DONE BY QUALIFIED WELDER TESTED TO BS EN 287-1.

FIXING LUG

THE SIZE OF GLASS FIXING LUG TO BE 2mm THK. AND SPACING @300mm C/C MAX. UNLESS OTHERS STATED.

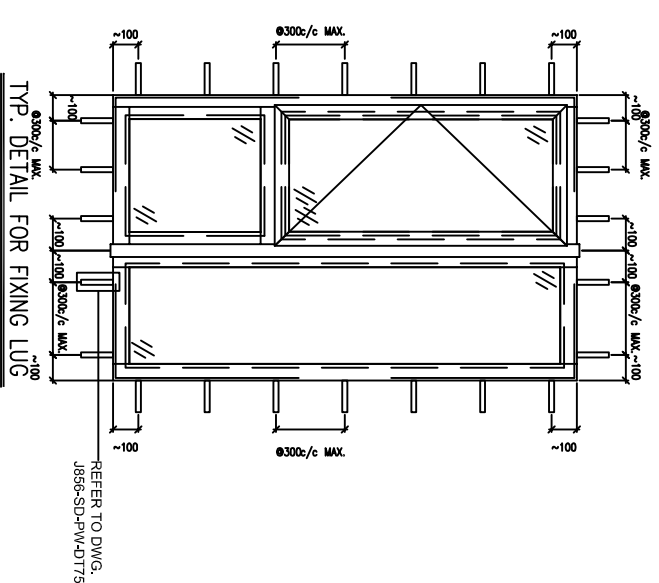

B.D. REF :

CLIENT :

SUN HUNG KAI
 REAL ESTATE AGENCY LTD.
 42/F SUN HUNG KAI CENTRE, WANCHAI, HONGKONG

ARCHITECT :

lwk&partners
 a r c h i t e c t s

MAIN CONTRACTOR :

Yee Fai 怡輝建築有限公司
 Building Contractors Ltd.

STRUCTURAL ENGINEER :

ARUP

FAÇADE CONSULTANT :

ALPHA CONSULTING LIMITED
 Steel Structure & Façade Specialist

NOTE :

1. ALL DIMENSIONS ARE IN mm.
2. ALL ELEVATIONS ARE VIEWED FROM OUTSIDE.
3. ALL DIMENSIONS TO BE VERIFIED ON SITE BEFORE FABRICATION.

LEGEND :

NO.	DATE	REVISION	BY

JOB NO. : J-856

PROJECT :
 PROPOSED DEVELOPMENT ABOVE
 LIGHT RAIL TIN WING STOP-TSMTL
 NO.23,AREA 33,TIN SHUI WAL, N.T.

TITLE :
 GENERAL NOTES FOR
 ALUM. WINDOW

DATE : 18-Aug-22 SCALE : 1:3

DRAWN BY : IYON CHECKED BY :

美特鋁質有限公司
MIDI ALUMINIUM FABRICATOR LTD.
 Units 6-8, Sunny Industrial Centre, 1/F
 610 Cho Kwong Road, Kowloon
 Tel:23489211-4 Fax:(852)27727666
 DWG NO. : J856-SD-PW-GN01 REV. : -

GENERAL NOTES FOR PRECAST ALUM. WINDOW PAGE 2

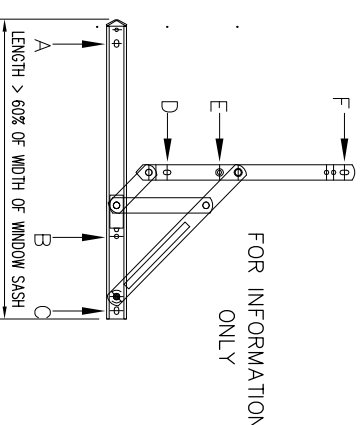
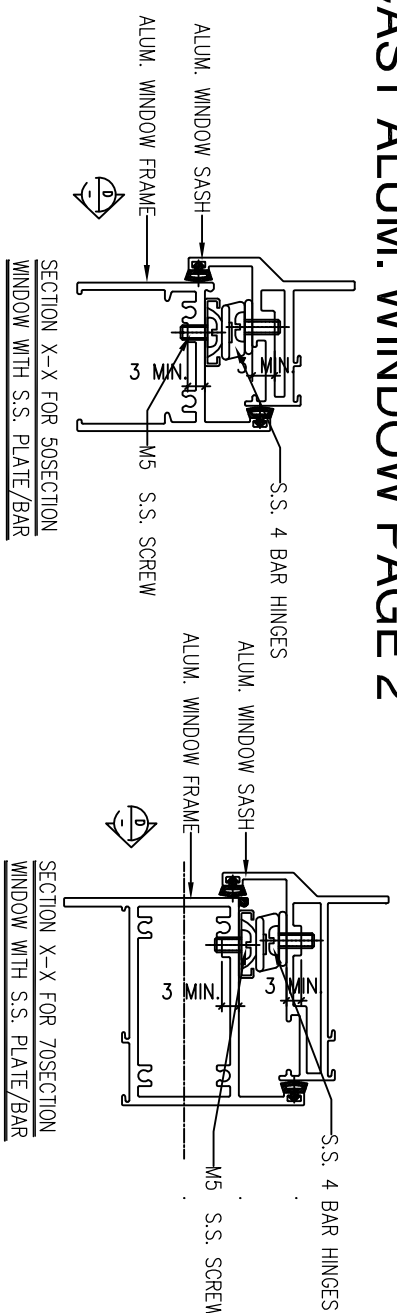
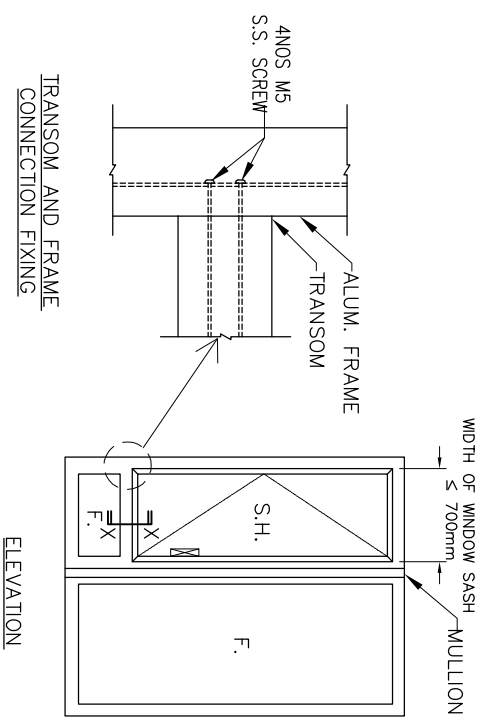

A,B,C,E,F-LOCATION FOR SCREW TO WINDOW FRAME/SASH
(LOCAL THICKENING BY S.S. PLATE/BAR(MIN.3mm))
D=LOCATION FOR SCREW TO WINDOW SASH
(LOCAL THICKENING BY ANGLE)
S.S. 4 BAR HINGE (LIP HINGE)

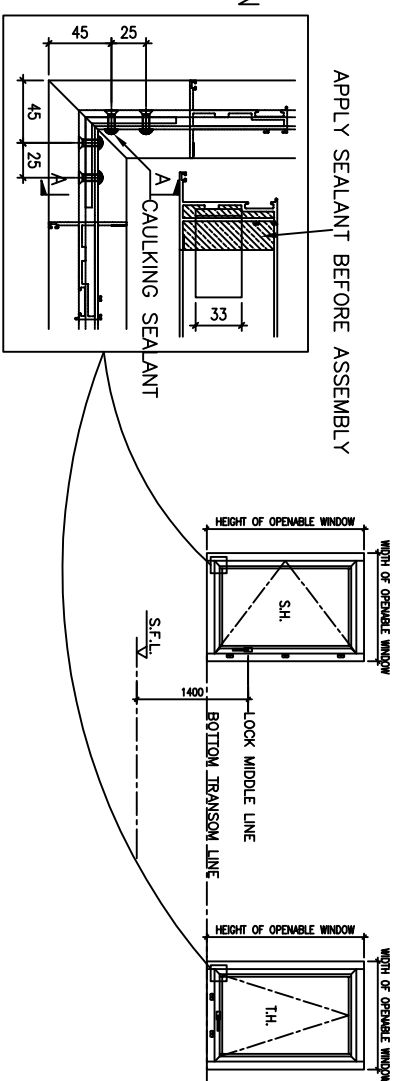
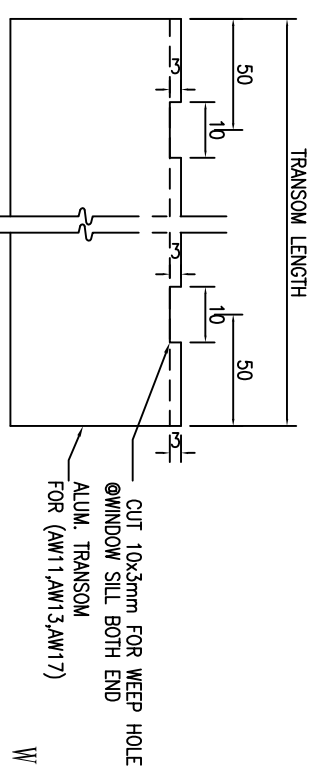

WINDOW SASH S. H. & T. H. LOADING TABLE

Window No.	W(mm)	H(mm)	GLAZING WEIGHT(kg)	BAR HINGE SH/TH	MAX. LOADINGS
AW02/02R	553	1146.5	32.41	HHMS-N16	53 42.4
AW02g/02gR	453	1146.5	27.22	HHMS-N12	41 32.8
AW02b/02bR	453	1146.5	27.22	HHMT-14	69.5 55.6
AW03/03R	553	1146.5	32.41	HHMS-N16	53 42.4
AW04/04R	553	1146.5	32.41	HHMS-N16	53 42.4
AW04g/04gR	553	1146.5	32.41	HHMS-N16	53 42.4
AW04b	553	1146.5	31.32	HHMT-14	69.5 55.6
AW06/06R	542	1172	21.41	HHMS-N16	53 42.4
AW07	532	1146.5	31.32	HHMS-N16	53 42.4
AW08	532	1146.5	31.32	HHMS-N16	53 42.4
AW09/09R	542	1146.5	31.84	HHMS-N16	53 42.4

CONFIGURATION FOR WINDOW DEVICES

- 1 STAINLESS STEEL 4 BAR HINGE
-LIP HINGE(MODEL: HHMS-N FOR SIDE HINGE)
-LIP HINGE(MODEL: HHMT FOR TOP HINGE)
- 2 LOCKING POINT
-LIP HINGE(MODEL: KMP/ABCP)
- 3 PULLING BLOCK
-LIP HINGE(MODEL: HBS/HHSS)
- 4 ALUMINIUM HANDLE
-LIP HINGE(MODEL: ALDPOB-10)
- 5 GLIDER
- 6 LIFT HINGE
-LIP HINGE(MODEL: TRST 10)

DIM. TABLE OF PULLING BLOCK (SH)

Window No.	H1(mm)	H2(mm)	H3(mm)
AW02/02R			
AW02g/02gR			
AW03/03R			
AW04/04R	285	576.5	1146.5
AW04g/04gR			
AW07			
AW08			
AW09/09R			
AW06/06R	293	586	1172

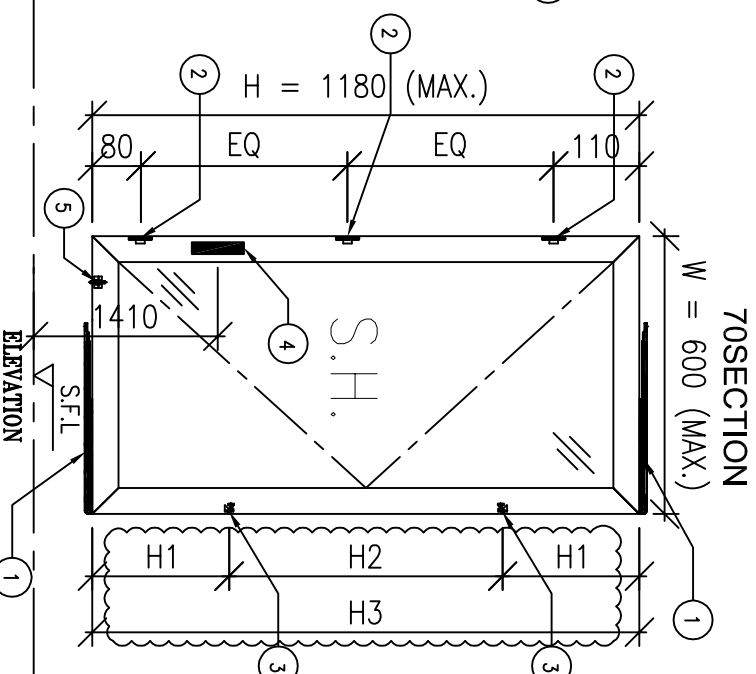
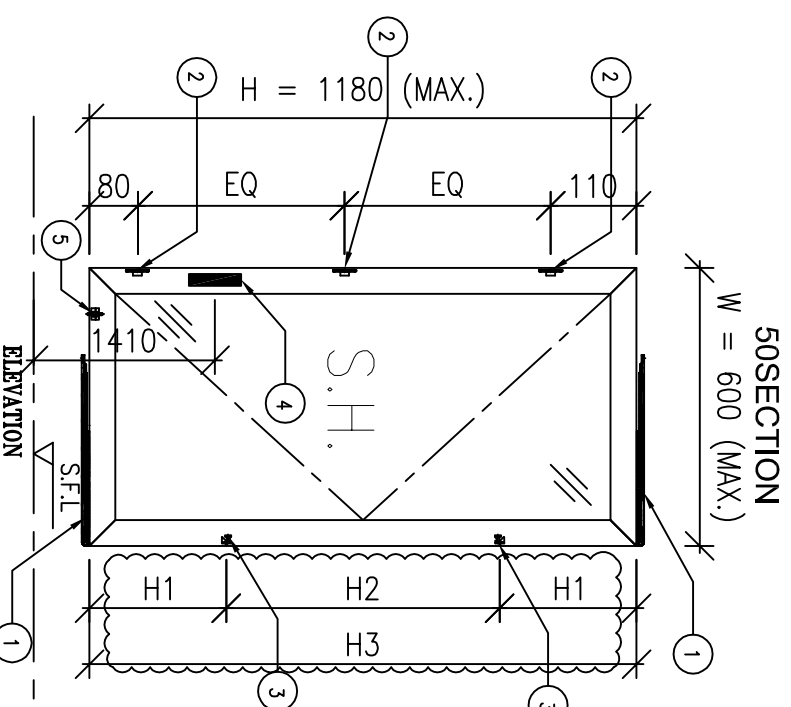
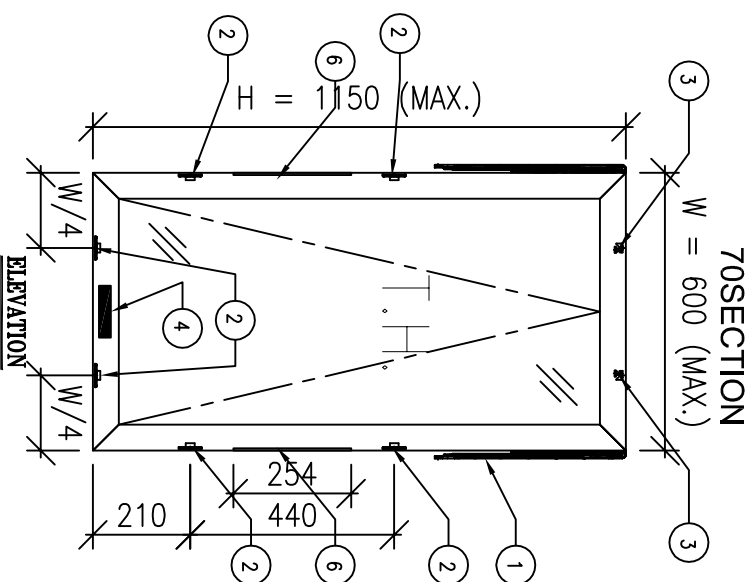

B.D. REF :

CLIENT :

SUN HUNG KAI
REAL ESTATE AGENCY LTD.
42/F SUN HUNG KAI CENTRE, WING LOK, HONGKONG

ARCHITECT :

lwk&partners
a r c h i t e c t s

MAIN CONTRACTOR :

Yee Fai
Building Contractors Ltd.

STRUCTURAL ENGINEER :

ARUP

FAÇADE CONSULTANT :

ALPHA CONSULTING LIMITED
Steel Structure & Façade Specialist

NOTE :

1. ALL DIMENSIONS ARE IN mm.
2. ALL ELEVATIONS ARE VIEWED FROM OUTSIDE.
3. ALL DIMENSIONS TO BE VERIFIED ON SITE BEFORE FABRICATION.

LEGEND :

NO.	DATE	REVISION	BY
C	28/10/2022	GENERAL REVISION	h
B	05/09/2022	REVISION SUBJECT TO ALPHA COMMENT	h
A	28/09/2022	REVISION SUBJECT TO ALPHA COMMENT	h

JOB NO. : J-856

PROJECT : PROPOSED DEVELOPMENT ABOVE LIGHT RAIL TIN WING STOP,TSWTL NO.23,AREA 33,TIN SHUI WAI, N.T.

TITLE : GENERAL NOTES FOR ALUM. WINDOW

DATE : 18-Aug-22 SCALE : 1:3

DRAWN BY : IYON CHECKED BY :

Unit 6-8, Sunray Industrial Centre, 1/F
610 Chee Kwo Ling Road, Kowloon
Tel:23492111-4 Fax:(852)2727666

DWG NO. : JB56-SD-PW-GN02 REV : C

PROPERTIES

MEMBER: AW-01
GRADE: 6063-T6
FINISH: PVF2 3-COATING

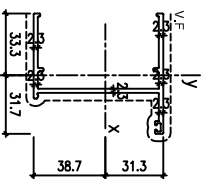

Table with 10 columns: No. of members, Material, Thickness, etc.

PROPERTIES

MEMBER: AW-05
GRADE: 6063-T6
FINISH: PVF2 3-COATING

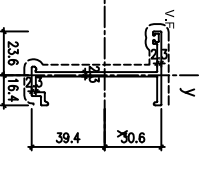

Table with 10 columns: No. of members, Material, Thickness, etc.

PROPERTIES

MEMBER: AW-09
GRADE: 6063-T6
FINISH: PVF2 3-COATING

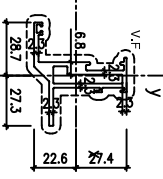

Table with 10 columns: No. of members, Material, Thickness, etc.

PROPERTIES

MEMBER: AW-13
GRADE: 6063-T6
FINISH: PVF2 3-COATING

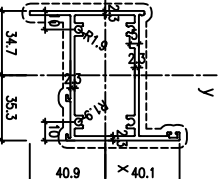

Table with 10 columns: No. of members, Material, Thickness, etc.

PROPERTIES

MEMBER: AW-02
GRADE: 6063-T6
FINISH: PVF2 3-COATING

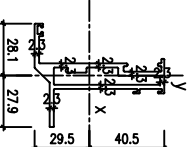

Table with 10 columns: No. of members, Material, Thickness, etc.

PROPERTIES

MEMBER: AW-06
GRADE: 6063-T6
FINISH: PVF2 3-COATING

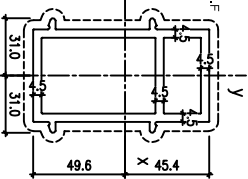

Table with 10 columns: No. of members, Material, Thickness, etc.

PROPERTIES

MEMBER: AW-10
GRADE: 6063-T6
FINISH: PVF2 3-COATING

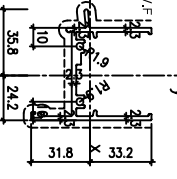

Table with 10 columns: No. of members, Material, Thickness, etc.

PROPERTIES

MEMBER: AW-14
GRADE: 6063-T6
FINISH: PVF2 3-COATING

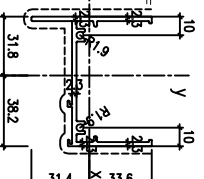

Table with 10 columns: No. of members, Material, Thickness, etc.

PROPERTIES

MEMBER: AW-03
GRADE: 6063-T6
FINISH: PVF2 3-COATING

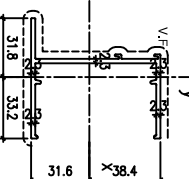

Table with 10 columns: No. of members, Material, Thickness, etc.

PROPERTIES

MEMBER: AW-07
GRADE: 6063-T6
FINISH: PVF2 3-COATING

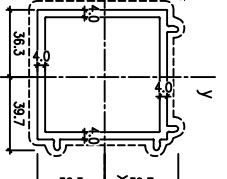

Table with 10 columns: No. of members, Material, Thickness, etc.

PROPERTIES

MEMBER: AW-11
GRADE: 6063-T6
FINISH: PVF2 3-COATING

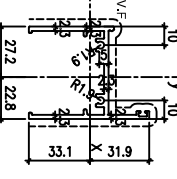

Table with 10 columns: No. of members, Material, Thickness, etc.

PROPERTIES

MEMBER: AW-15
GRADE: 6063-T6
FINISH: PVF2 3-COATING

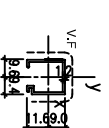

Table with 10 columns: No. of members, Material, Thickness, etc.

PROPERTIES

MEMBER: AW-04
GRADE: 6063-T6
FINISH: PVF2 3-COATING

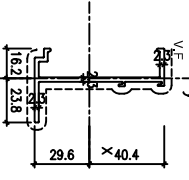

Table with 10 columns: No. of members, Material, Thickness, etc.

PROPERTIES

MEMBER: AW-08
GRADE: 6063-T6
FINISH: PVF2 3-COATING

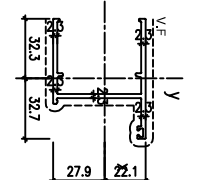

Table with 10 columns: No. of members, Material, Thickness, etc.

PROPERTIES

MEMBER: AW-12
GRADE: 6063-T6
FINISH: PVF2 3-COATING

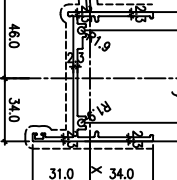

Table with 10 columns: No. of members, Material, Thickness, etc.

PROPERTIES

MEMBER: AW-16
GRADE: 6063-T6
FINISH: PVF2 3-COATING

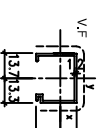

Table with 10 columns: No. of members, Material, Thickness, etc.

B.D. REF:

CLIENT: SUN HUNG KAI REAL ESTATE AGENCY LTD. 42/F SUN HUNG KAI CENTRE, WANCHAI, HONGKONG

ARCHITECT: Iw&partners

MANU CONTRACTOR: Yee Fai Building Contractors Ltd.

STRUCTURAL ENGINEER: ARUP

FAÇADE CONSULTANT: ALPHA CONSULTING LIMITED

NOTE: 1. ALL DIMENSIONS ARE IN mm. 2. ALL ELEVATIONS ARE VIEWED FROM OUTSIDE. 3. ALL DIMENSIONS TO BE VERIFIED ON SITE BEFORE FABRICATION.

LEGEND: (X1) DETAIL MARK NO. (X001) REEFER SHEET NO.

MEMBER: AW-13, GRADE: 6063-T6, FINISH: PVF2 3-COATING. PROJECT: PROPOSED DEVELOPMENT ABOVE LIGHT RAIL TIN WING STOP-TSWTL NO.23, AREA 33, TIN SHUI WAI, N.T.

DATE: 02-Aug-21, SCALE: 1:40. DRAWN BY: IYON, CHECKED BY:

UNITED STATES OF AMERICA: 美特铝质有限公司. 610 Cho Kwong Road, Kowloon.

B.D. REF :

CLIENT :

SUN HUNG KAI
REAL ESTATE AGENCY LTD.
42/F SUN HUNG KAI CENTRE, WANCHAI, HONGKONG

ARCHITECT :

lwk&partners
a r c h i t e c t s

MAIN CONTRACTOR :

Yee Fai 怡輝建築有限公司
Building Contractors Ltd.

STRUCTURAL ENGINEER :

ARUP

FAÇADE CONSULTANT:

ALPHA CONSULTING LIMITED
Steel Structure & Façade Specialist

NOTE :

1. ALL DIMENSIONS ARE IN mm.
2. ALL ELEVATIONS ARE VIEWED FROM OUTSIDE.
3. ALL DIMENSIONS TO BE VERIFIED ON SITE BEFORE FABRICATION.

LEGEND :

(X1) --- DETAIL MARK NO.
(X001) --- REFER SHEET NO.

1. F.F.L. --- FINISHED FLOOR LEVEL
2. S.F.L. --- STRUCTURAL FLOOR LEVEL
3. (R) --- REVERSED DETAIL

4. GLASS LEGEND

EQ.-1---8mmH+12mm AIR GAP+8mmTP THK. I.G.U.
EQ.-2---10mm THK. CLEAR TEMPERED GLASS
EQ.-4---10mm THK. TEMPERED ACID ETCHED GLASS

NO.	DATE	REVISION	REVISION SUBJECT TO ARCH/COMMENT	BY
D	16/08/2022	REVISION SUBJECT TO ARCH/COMMENT		HW
C	27/06/2022	REVISION SUBJECT TO ARCH/COMMENT		HW
B	21/12/2021	REVISION SUBJECT TO ARCH/COMMENT		HW
A	29/10/2021	REVISION SUBJECT TO ARCH/COMMENT		HW

JOB NO. : J-856

PROJECT :

PROPOSED DEVELOPMENT ABOVE
LIGHT RAIL TIN WING STOP TSWLT
NO.23,AREA 33,TIN SHUI WAI, N.T.

TITLE : PLAN FOR ALUM. WINDOW
AT TOWER 1

DATE : 02-Aug-21

SCALE : 1:40

DRAWN BY : Iwon

CHECKED BY :

美特鋁質有限公司
MIDI ALUMINUM FABRICATOR LTD.
Units 6-8, Sunny Industrial Centre, 1/F
610 Cho Kwo Ling Road, Kwailoon
Tel:23489211-4 Fax:(852)27272666

DWG NO. : J856-SD-PW-3101

REV. : D

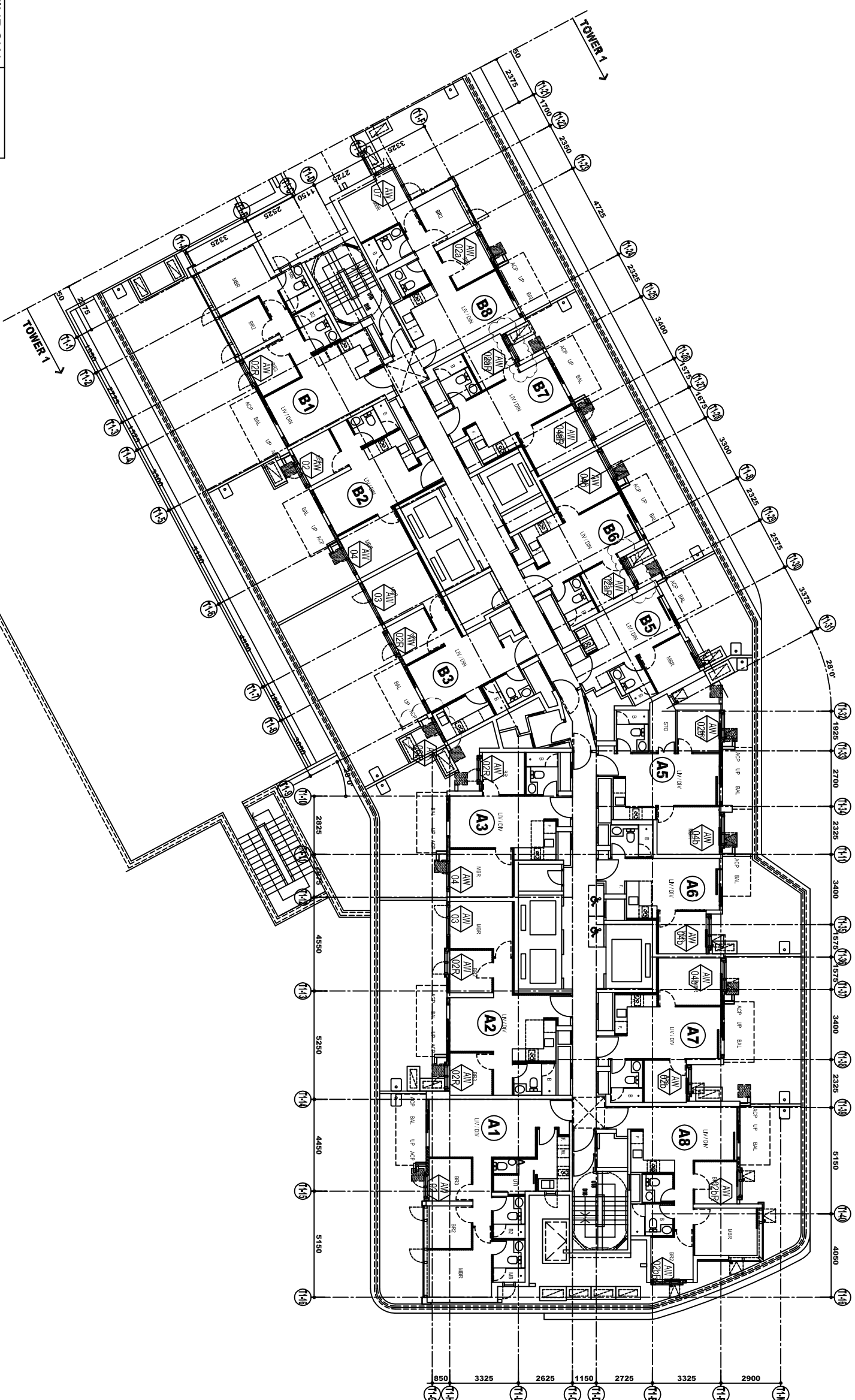

WINDOW MARK	QUANTITY
AW-02	2
AW-02R	5
AW-02a	1
AW-02aR	2
AW-02b	2
AW-02bR	2
AW-03	2
AW-04	2
AW-04aR	1
AW-04b	4
AW-06R	1
AW-07	1

TOWER 1 3/F

B.O. REF :

CLIENT :

SUN HUNG KAI
REAL ESTATE AGENCY LTD.
42/F SUN HUNG KAI CENTRE, WINGHAI, HONGKONG

ARCHITECT :

lwk&partners
A R C H I T E C T S

MAIN CONTRACTOR :

Yee Fai 怡輝建築有限公司
Building Contractors Ltd.

STRUCTURAL ENGINEER :

ARUP

FAÇADE CONSULTANT :

ALPHA CONSULTING LIMITED
Steel Structure & Façade Specialist

NOTE :

1. ALL DIMENSIONS ARE IN mm.
2. ALL ELEVATIONS ARE VIEWED FROM OUTSIDE.
3. ALL DIMENSIONS TO BE VERIFIED ON SITE BEFORE FABRICATION.

LEGEND :

- ⊗11 --- DETAIL MARK NO.
- ⊗001 --- REFER SHEET NO.

1. F.F.L. --- FINISHED FLOOR LEVEL
2. S.F.L. --- STRUCTURAL FLOOR LEVEL
3. Ⓡ --- REVERSED DETAIL
4. GLASS LEGEND

EQ1-1---8mmHS+12mm AIR GAP+8mmTP THK. L.G.U.
EQ1-2---10mm THK. CLEAR TEMPERED GLASS
EQ1-4---10mm THK. TEMPERED ACID ETCHED GLASS

NO.	DATE	REVISION
A	18/10/2021	REVISION SUBJECT TO ARCHITECTMENT
B	03/11/2021	REVISION SUBJECT TO ARCHITECTMENT
C	29/11/2021	REVISION SUBJECT TO ARCHITECTMENT
D	27/06/2022	REVISION SUBJECT TO ARCHITECTMENT
E	16/09/2022	REVISION SUBJECT TO ARCHITECTMENT
F	26/10/2022	UPDATE G&P PLAN

JOB NO. : J-856

PROJECT : PROPOSED DEVELOPMENT ABOVE LIGHT RAIL TIN WING STOP.TSWTL NO.23,AREA 33,TIN SHUI WAI, N.T.

TITLE : PLAN FOR IN-SITU WINDOW AT TOWER 1

DATE : 02-Aug-21 SCALE : 1:40

DRAWN BY : Ivon CHECKED BY :

美特鋁寶有限公司
MIDI ALUMINIUM FABRICATOR LTD.
Units 6-8, Sunray Industrial Centre, 1/F
610 Cho Kwong Road, Kowloon
Tel:23489211-4 Fax:(852)27277866
DWG NO. : J856-SD-IW-3102 REV. : F

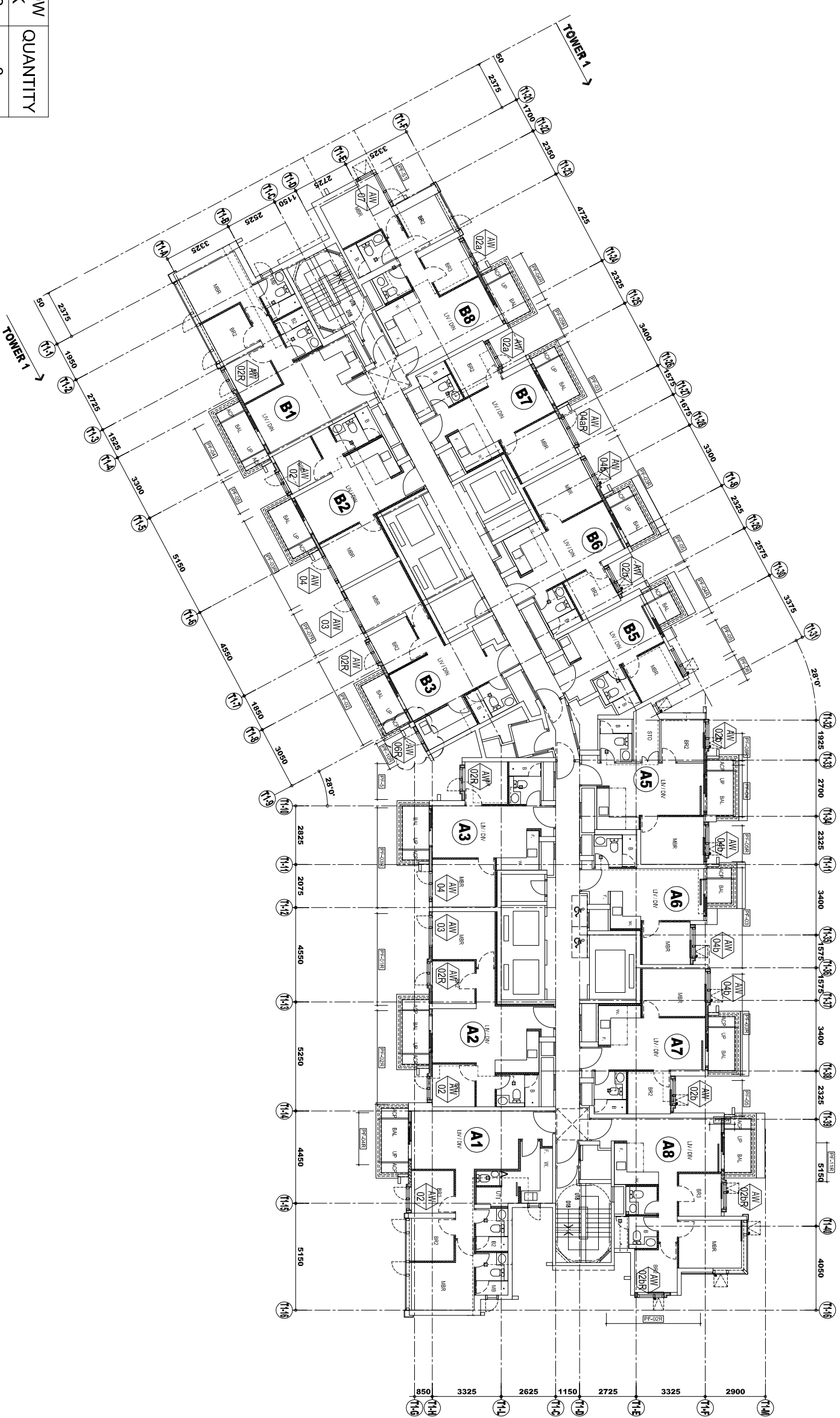

WINDOW MARK	QUANTITY
AW-02	3
AW-02R	4
AW-02a	2
AW-02b	3
AW-02bR	2
AW-03	2
AW-04	2
AW-04aR	1
AW-04b	4
AW-06R	1
AW-07	1

TOWER 1 5/F-42/F

B.O. REF :

← TOWER 2

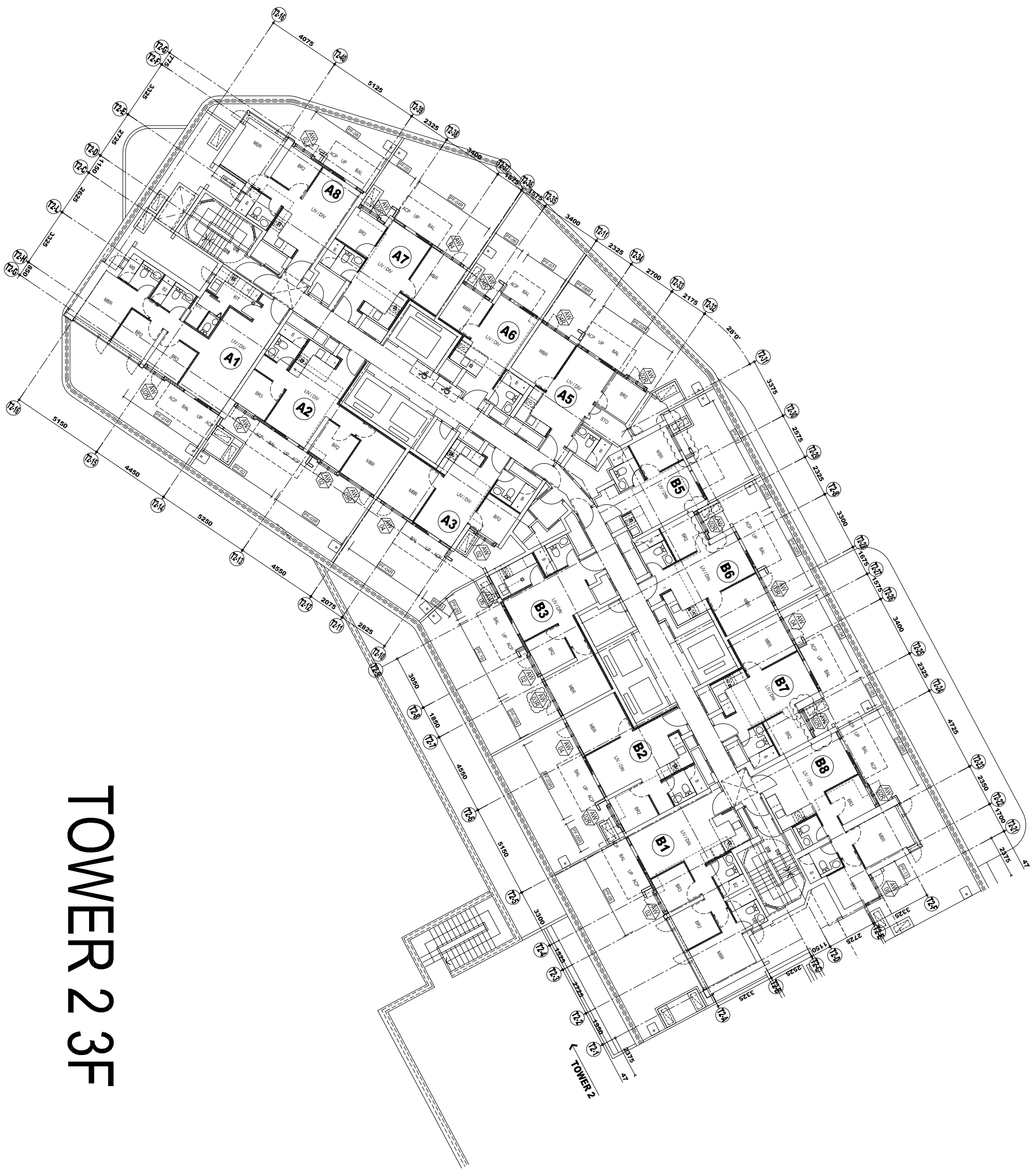

TOWER 2 3F

WINDOW MARK	QUANTITY
AW-02	6
AW-02R	7
AW-03R	3
AW-04	4
AW-04R	2
AW-06	1
AW-08	1

CLIENT :

SUN HUNG KAI
REAL ESTATE AGENCY LTD.
 42/F SUN HUNG KAI CENTRE, WANGCHAI, HONGKONG

ARCHITECT :

lwk&partners
 A R C H I T E C T S

MAIN CONTRACTOR :

怡輝建築有限公司
Yee Fai Building Contractors Ltd.

STRUCTURAL ENGINEER :

ARUP

FAÇADE CONSULTANT:

ALPHA CONSULTING LIMITED
 Steel Structure & Façade Specialist

NOTE :

1. ALL DIMENSIONS ARE IN mm.
2. ALL ELEVATIONS ARE VIEWED FROM OUTSIDE.
3. ALL DIMENSIONS TO BE VERIFIED ON SITE BEFORE FABRICATION.

LEGEND :

- ⊗11—DETAIL MARK NO.
- ⊗001—REFER SHEET NO.

1. F.F.L.—FINISHED FLOOR LEVEL
2. S.F.L.—STRUCTURAL FLOOR LEVEL
3. Ⓡ—REVERSED DETAIL

4. GLASS LEGEND

- EQ1-1--8mmHS+12mm AIR GAP+18mmTP THK. LG.U.
- EQ1-2--10mm THK. CLEAR TEMPERED GLASS
- EQ1-4--10mm THK. TEMPERED ACID ETCHED GLASS

NO.	DATE	REVISION
E	16/8/2022	REVISION SUBJECT TO ARCH/COMMITMENT
D	27/6/2022	REVISION SUBJECT TO ARCH/COMMITMENT
C	18/5/2022	REVISION SUBJECT TO ARCH/COMMITMENT
B	12/7/2022	REVISION SUBJECT TO ARCH/COMMITMENT
A	26/11/2021	REVISION SUBJECT TO ARCH/COMMITMENT

JOB NO. : J-856

PROJECT :

PROPOSED DEVELOPMENT ABOVE
 LIGHT RAIL TIN WING STOP TSWTL
 NO.23,AREA 33,TIN SHUI WAI, N.T.

TITLE :

PLAN FOR PRECAST WINDOW
 AT TOWER 2

DATE : 02-Aug-21 SCALE : 1:40

DRAWN BY : Ivon CHECKED BY :

美特鋁質有限公司
MIDI ALUMINIUM FABRICATOR LTD.
 Units 6-8, Sunray Industrial Centre, 1/F
 610 Cho Kwong Road, Kwun Tong, Kowloon
 Tel:23489211-4 Fax:(852)27277866
 DWG NO. : J856-SD-IW-3201 REV. : E

B.O. REF :

CLIENT :

SUN HUNG KAI
REAL ESTATE AGENCY LTD.

42/F, SUN HUNG KAI CENTRE, WINGHAI, HONGKONG

ARCHITECT :

IWK&partners
A R C H I T E C T S

MAIN CONTRACTOR :

Yee Fai 怡輝建築有限公司
Building Contractors Ltd.

STRUCTURAL ENGINEER :

ARUP
ALPHA CONSULTING LIMITED
Steel Structure & Facade Specialist

FAÇADE CONSULTANT:

ALPHA CONSULTING LIMITED
Steel Structure & Facade Specialist

NOTE :

1. ALL DIMENSIONS ARE IN mm.
2. ALL ELEVATIONS ARE VIEWED FROM OUTSIDE.
3. ALL DIMENSIONS TO BE VERIFIED ON SITE BEFORE FABRICATION.

LEGEND :

- (X1) DETAIL MARK NO.
- (X001) REFER SHEET NO.

1. F.F.L. -- FINISHED FLOOR LEVEL
2. S.F.L. -- STRUCTURAL FLOOR LEVEL
3. (R) -- REVERSED DETAIL
4. GLASS LEGEND

EQ-1 -- 8mmHS+12mm AIR GAP+8mmTP THK. L.G.U.
 EQ-2 -- 10mm THK. CLEAR TEMPERED GLASS
 EQ-4 -- 10mm THK. TEMPERED ACID ETCHED GLASS

NO.	DATE	REVISION
H	26/10/2022	UPDATE GSP PLAN
G	16/8/2022	REVISION SUBJECT TO ARCH/COMMITMENT
F	27/6/2022	REVISION SUBJECT TO ARCH/COMMITMENT
E	18/5/2022	REVISION SUBJECT TO ARCH/COMMITMENT
D	12/1/2022	REVISION SUBJECT TO ARCH/COMMITMENT
C	26/11/2021	REVISION SUBJECT TO ARCH/COMMITMENT
B	03/11/2021	REVISION SUBJECT TO ARCH/COMMITMENT
A	18/10/2021	REVISION SUBJECT TO ARCH/COMMITMENT

JOB NO. : J-856

PROJECT :

PROPOSED DEVELOPMENT ABOVE
LIGHT RAIL TIN WING STOP-TSWTL
NO.23,AREA 33,TIN SHUI WAI, N.T.

TITLE : PLAN FOR PRECAST WINDOW

AT TOWER 2

DATE : 02-Aug-21 SCALE : 1:40

DRAWN BY : Ivon CHECKED BY :

MIDI 美特鋁寶有限公司
ALUMINIUM FABRICATOR LTD.

Units 6-8, Sunray Industrial Centre, 1/F
610 Cho Kwong Road, Kowloon
Tel:23489211-4 Fax:(852)27277866

DWG NO. : J856-SD-IW-3202 REV. : H

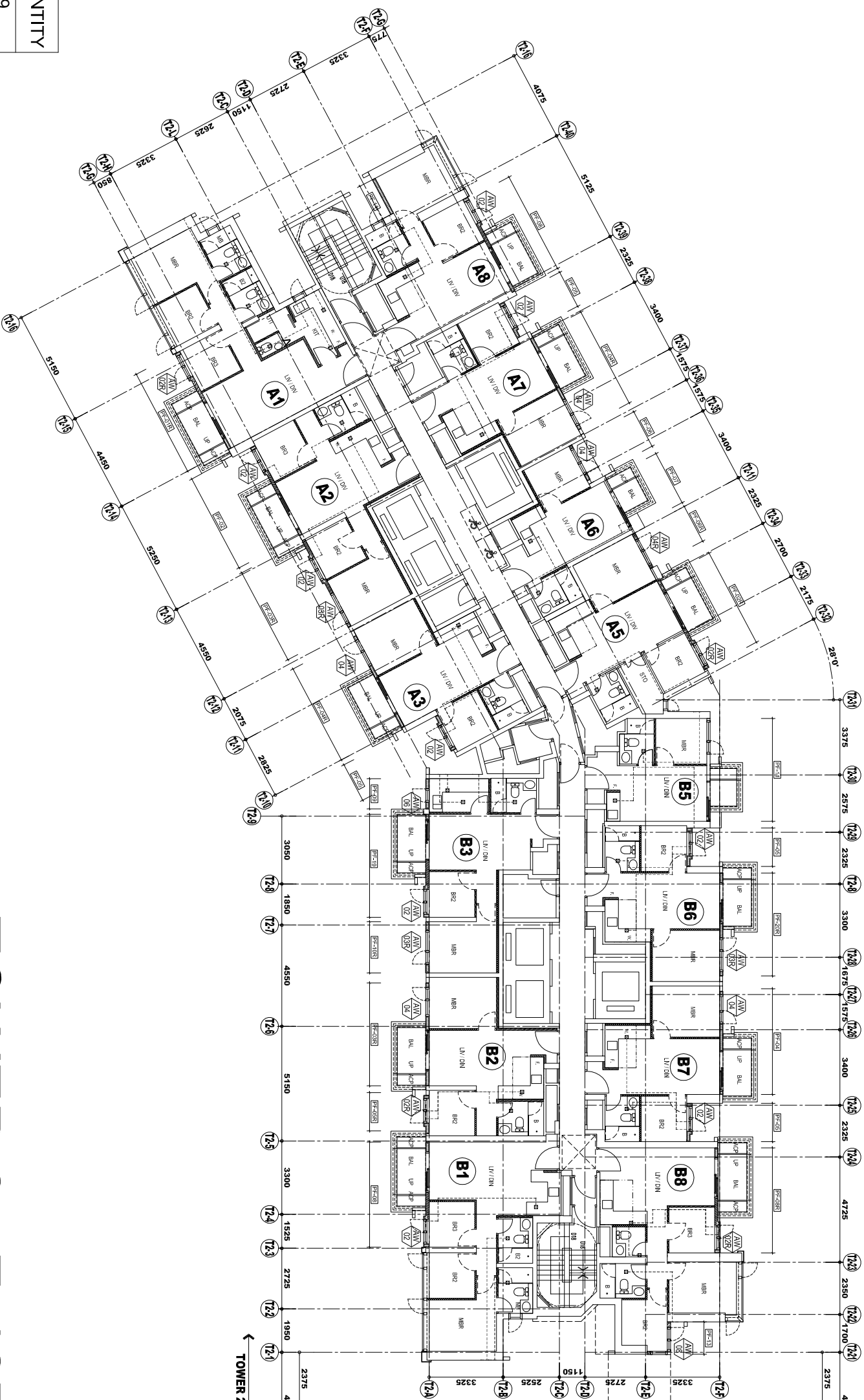

WINDOW MARK	QUANTITY
AW-02	9
AW-02R	4
AW-03R	3
AW-04	5
AW-04R	1
AW-06	1
AW-08	1

TOWER 2 5F-42F

B.O. REF :

CLIENT :

SUN HUNG KAI
REAL ESTATE AGENCY LTD.
42/F SUN HUNG KAI CENTRE, WANCHAI, HONGKONG

ARCHITECT :

lwk&partners
A R C H I T E C T S

MAIN CONTRACTOR :

怡輝建築有限公司
Yee Fai Building Contractors Ltd.

STRUCTURAL ENGINEER :

ARUP

FAÇADE CONSULTANT:

ALPHA CONSULTING LIMITED
Steel Structure & Façade Specialist

NOTE :

1. ALL DIMENSIONS ARE IN mm.
2. ALL ELEVATIONS ARE VIEWED FROM OUTSIDE.
3. ALL DIMENSIONS TO BE VERIFIED ON SITE BEFORE FABRICATION.

LEGEND :

⊗11 --- DETAIL MARK NO.
⊗001 --- REFER SHEET NO.

1. F.F.L. --- FINISHED FLOOR LEVEL
2. S.F.L. --- STRUCTURAL FLOOR LEVEL
3. ⊗R --- REVERSED DETAIL
4. GLASS LEGEND

EGL-1---8mmHS+12mm AIR GAP+8mmTP THK. L.G.U.
EGL-2---10mm THK. CLEAR TEMPERED GLASS
EGL-4---10mm THK. TEMPERED ACID ETCHED GLASS

NO.	DATE	REVISION	SUBJECT TO ARCHITECTMENT
A.	29/11/2021	REVISION	SUBJECT TO ARCHITECTMENT
B.	21/12/2021	REVISION	SUBJECT TO ARCHITECTMENT
C.	22/04/2022	REVISION	SUBJECT TO ARCHITECTMENT
D.	19/05/2022	REVISION	SUBJECT TO ARCHITECTMENT
E.	27/06/2022	REVISION	SUBJECT TO ARCHITECTMENT
F.	16/08/2022	REVISION	SUBJECT TO ARCHITECTMENT
G.	26/10/2022	UPDATE	OSP PLAN

JOB NO. : J-856

PROJECT :

PROPOSED DEVELOPMENT ABOVE
LIGHT RAIL TIN WING STOP-TSWTL
NO.23,AREA 33,TIN SHUI WAI, N.T.

TITLE : PLAN FOR PRECAST WINDOW

AT TOWER 3

DATE : 02-Aug-21 SCALE : 1:40

DRAWN BY : Ivon CHECKED BY :

美特鋁質有限公司
MIDI ALUMINIUM FABRICATOR LTD.
Units 6-8, Sunray Industrial Centre, 1/F
610 Cho Kwong Road, Kowloon
Tel:23489211-4 Fax:(852)27277866

DWG NO. : J856-SD-IW-3301 REV. : G

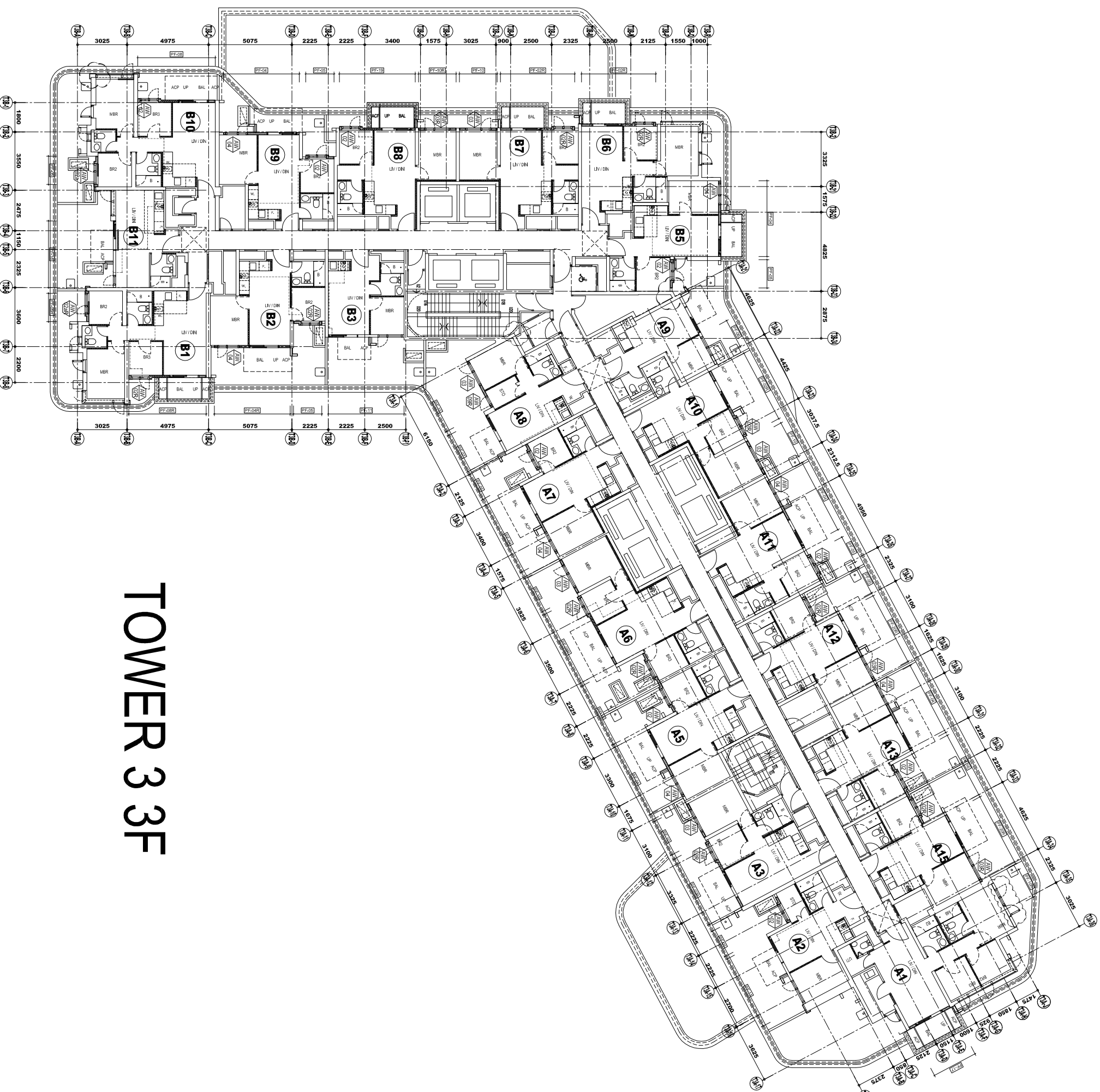

TOWER 3 3F

WINDOW MARK	QUANTITY
AW-02	9
AW-02R	10
AW-02a	1
AW-02aR	1
AW-03	5
AW-03R	3
AW-04	7
AW-09R	1

B.O. REF :

CLIENT :

SUN HUNG KAI
REAL ESTATE AGENCY LTD.
42/F SUN HUNG KAI CENTRE, WINGHUA, HONGKONG

ARCHITECT :

Iwk&partners
A R C H I T E C T S

MAIN CONTRACTOR :

Yee Fai 怡輝建築有限公司
Building Contractors Ltd.

STRUCTURAL ENGINEER :

ARUP
ALPHA CONSULTING LIMITED
Steel Structure & Facade Specialist

FAÇADE CONSULTANT:

ARUP
ALPHA CONSULTING LIMITED
Steel Structure & Facade Specialist

NOTE :

1. ALL DIMENSIONS ARE IN mm.
2. ALL ELEVATIONS ARE VIEWED FROM OUTSIDE.
3. ALL DIMENSIONS TO BE VERIFIED ON SITE BEFORE FABRICATION.

LEGEND :

- ⊗11—DETAIL MARK NO.
- ⊗001—REFER SHEET NO.

1. F.F.L.--FINISHED FLOOR LEVEL
2. S.F.L.--STRUCTURAL FLOOR LEVEL
3. Ⓡ--REVERSED DETAIL
4. GLASS LEGEND

EQ-1--8mmHS+12mm AIR GAP+8mmTP THK. LG.U.
EQ-2--10mm THK. CLEAR TEMPERED GLASS
EQ-4--10mm THK. TEMPERED ACID ETCHED GLASS

NO.	DATE	REVISION	REVISION SUBJECT TO ARCHITECTMENT
L	26/10/2022	UPDATE GSP PLAN	11
K	16/09/2022	REVISION SUBJECT TO ARCHITECTMENT	10
J	27/06/2022	REVISION SUBJECT TO ARCHITECTMENT	9
I	19/05/2022	REVISION SUBJECT TO ARCHITECTMENT	8
H	22/04/2022	REVISION SUBJECT TO ARCHITECTMENT	7
G	09/04/2022	REVISION SUBJECT TO ARCHITECTMENT	6
F	12/01/2022	REVISION SUBJECT TO ARCHITECTMENT	5

JOB NO. : J-856

PROJECT :

PROPOSED DEVELOPMENT ABOVE
LIGHT RAIL TIN WING STOP TSWTL
NO.23,AREA 33,TIN SHUI WAI, N.T.

TITLE : PLAN FOR PRECAST WINDOW
AT TOWER 3

DATE : 02-Aug-21 SCALE : 1:40

DRAWN BY : Ivon CHECKED BY :

美特鋁質有限公司
MIDI ALUMINIUM FABRICATOR LTD.
Units 6-8, Sunray Industrial Centre, 1/F
610 Cho Kwong Road, Kowloon
Tel:23489211-4 Fax:(852)27277866

DWG NO. : J856-SD-IW-3302 REV. : L

WINDOW MARK	QUANTITY
AW-02	11
AW-02R	8
AW-02a	1
AW-02aR	1
AW-03	5
AW-03R	4
AW-04	7
AW-09R	1



TOWER 3 5F-42F

LOCATION	OPENABLE AREA	GLAZING AREA	OPENABLE AREA	GLAZING AREA
A1-BR1	0.263	0.420	0.548	0.985
B1-BR1	0.263	0.420		

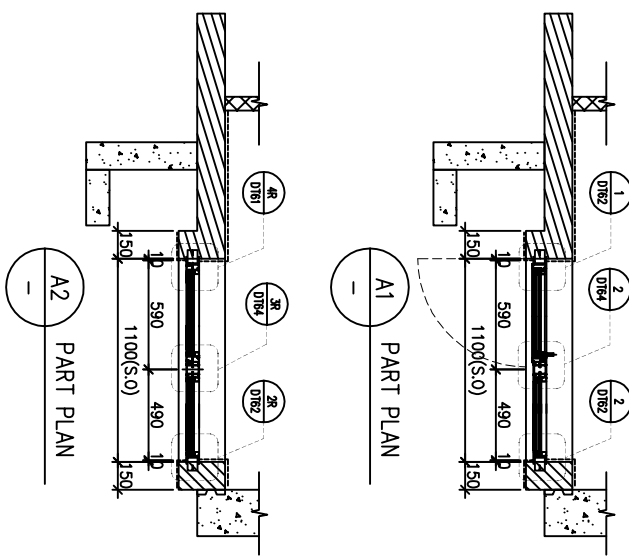
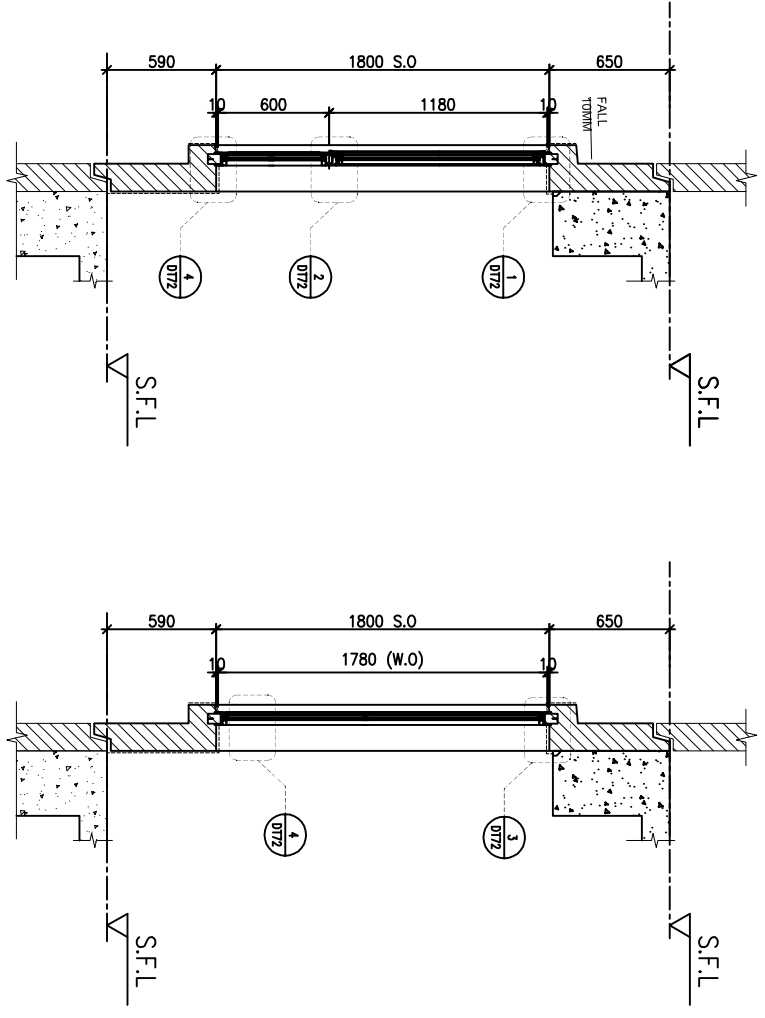
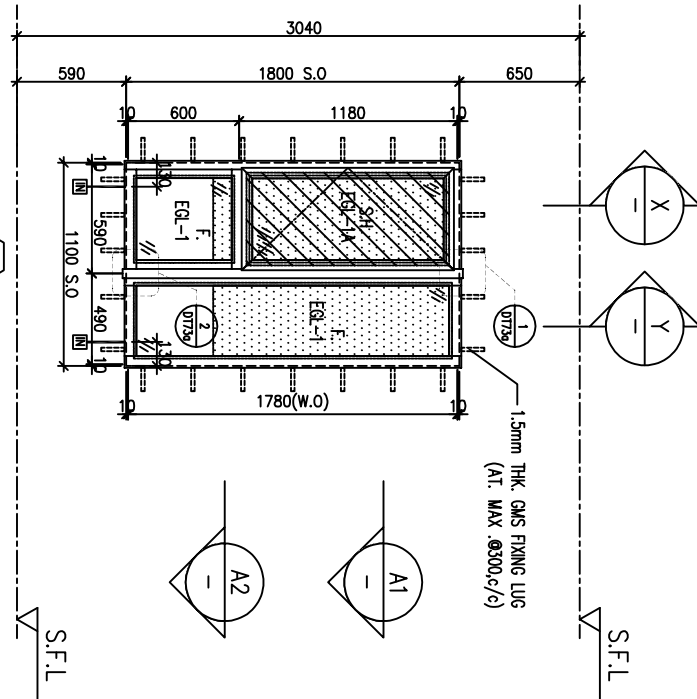

ELEVATION

WINDOW MARK	REQUIRE	PROVIDED
AW 02	0.263	0.548
GLAZING	EGL-1, EGL-1A	EGL-1, EGL-1A
QUANTITY	35 Nos.	35 Nos
REMARKS	FACADE(TYPE T1PF04R FOR 3/F~42/F) , 4 BAR HINGE-LIP HING (HHMS-N16)	

BD. REF :																																	
CLIENT :	SUN HUNG KAI REAL ESTATE AGENCY LTD. 42/F SUN HUNG KAI CENTRE, WANCHAI, HONGKONG																																
ARCHITECT :	lwk&partners a r c h i t e c t s																																
MAIN CONTRACTOR :	怡輝建築有限公司 Yee Fai Building Contractors Ltd.																																
STRUCTURAL ENGINEER :	ARUP ALPHA CONSULTING LIMITED Steel Structure & Façade Specialist																																
FACADE CONSULTANT :	ARUP ALPHA CONSULTING LIMITED Steel Structure & Façade Specialist																																
NOTE :	1. ALL DIMENSIONS ARE IN mm. 2. ALL ELEVATIONS ARE VIEWED FROM OUTSIDE. 3. ALL DIMENSIONS TO BE VERIFIED ON SITE BEFORE FABRICATION. LEGEND : (X1) --- DETAIL MARK NO. (X001) --- REFER SHEET NO. 1. F.F.L. --- FINISHED FLOOR LEVEL 2. S.F.L. --- STRUCTURAL FLOOR LEVEL 3. (R) --- REVERSED DETAIL 4. GLASS LEGEND EGL-1 --- 8mmHS+12mm AIR GAP+10mmTP THK. I.G.U. EGL-2 --- 10mm THK. CLEAR TEMPERED GLASS EGL-4 --- 10mm THK. TEMPERED ACID ETCHED GLASS EGL-1A --- 8mmHS+12mm AIR GAP+8mmTP THK. I.G.U. EGL-1B --- 8mmHS+12mm AIR GAP+10mmTP ACID-ETCHED THK. I.G.U.																																
REVISION	<table border="1"> <thead> <tr> <th>NO.</th> <th>DATE</th> <th>REVISION</th> <th>BY</th> </tr> </thead> <tbody> <tr> <td>G</td> <td>21/09/2022</td> <td>REVISION SUBJECT TO ARCH-COMMENT</td> <td>HW</td> </tr> <tr> <td>F</td> <td>17/08/2022</td> <td>REVISION SUBJECT TO ARCH-COMMENT</td> <td>HW</td> </tr> <tr> <td>E</td> <td>06/07/2022</td> <td>REVISION SUBJECT TO ARCH-COMMENT</td> <td>HW</td> </tr> <tr> <td>D</td> <td>17/12/2021</td> <td>REVISION SUBJECT TO ARCH-COMMENT</td> <td>HW</td> </tr> <tr> <td>C</td> <td>29/11/2021</td> <td>REVISION SUBJECT TO ARCH-COMMENT</td> <td>HW</td> </tr> <tr> <td>B</td> <td>03/11/2021</td> <td>REVISION SUBJECT TO ARCH-COMMENT</td> <td>HW</td> </tr> <tr> <td>A</td> <td>12/10/2021</td> <td>REVISION SUBJECT TO ARCH-COMMENT</td> <td>HW</td> </tr> </tbody> </table>	NO.	DATE	REVISION	BY	G	21/09/2022	REVISION SUBJECT TO ARCH-COMMENT	HW	F	17/08/2022	REVISION SUBJECT TO ARCH-COMMENT	HW	E	06/07/2022	REVISION SUBJECT TO ARCH-COMMENT	HW	D	17/12/2021	REVISION SUBJECT TO ARCH-COMMENT	HW	C	29/11/2021	REVISION SUBJECT TO ARCH-COMMENT	HW	B	03/11/2021	REVISION SUBJECT TO ARCH-COMMENT	HW	A	12/10/2021	REVISION SUBJECT TO ARCH-COMMENT	HW
NO.	DATE	REVISION	BY																														
G	21/09/2022	REVISION SUBJECT TO ARCH-COMMENT	HW																														
F	17/08/2022	REVISION SUBJECT TO ARCH-COMMENT	HW																														
E	06/07/2022	REVISION SUBJECT TO ARCH-COMMENT	HW																														
D	17/12/2021	REVISION SUBJECT TO ARCH-COMMENT	HW																														
C	29/11/2021	REVISION SUBJECT TO ARCH-COMMENT	HW																														
B	03/11/2021	REVISION SUBJECT TO ARCH-COMMENT	HW																														
A	12/10/2021	REVISION SUBJECT TO ARCH-COMMENT	HW																														
JOB NO. :	J-856																																
PROJECT :	PROPOSED DEVELOPMENT ABOVE LIGHT RAIL TIN WING STOP-TSWTL NO.23,AREA 33,TIN SHUI WAI, N.T.																																
TITLE :	WINDOW SCHEDULE FOR TOWER 1 ALUM. WINDOW																																
DATE :	02-Aug-21																																
SCALE :	1:40																																
DRAWN BY :	Ivon																																
CHECKED BY :																																	
UNIT :	mm																																
PROJECT :	PROPOSED DEVELOPMENT ABOVE LIGHT RAIL TIN WING STOP-TSWTL NO.23,AREA 33,TIN SHUI WAI, N.T.																																
CLIENT :	UNITA 6-8, Sunray Industrial Centre, 1/F, 610 Chee Kwo Ling Road, Kowloon																																
CONTACT :	Tel:23489211-4 Fax:6522727666																																
DWG NO. :	1856-SD-PW-5101																																
REV. :	G																																

REQUIRED		PROVIDED		
LOCATION	OPENABLE AREA	GLAZING AREA	OPENABLE AREA	GLAZING AREA
A2-BR1	0.263	0.420	0.548	0.985
B3-BR1	0.263	0.420		

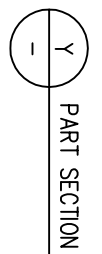
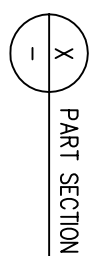
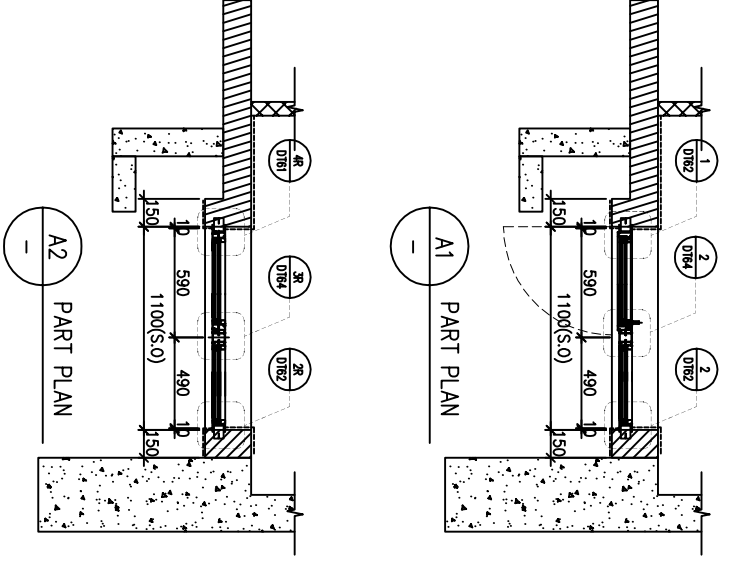
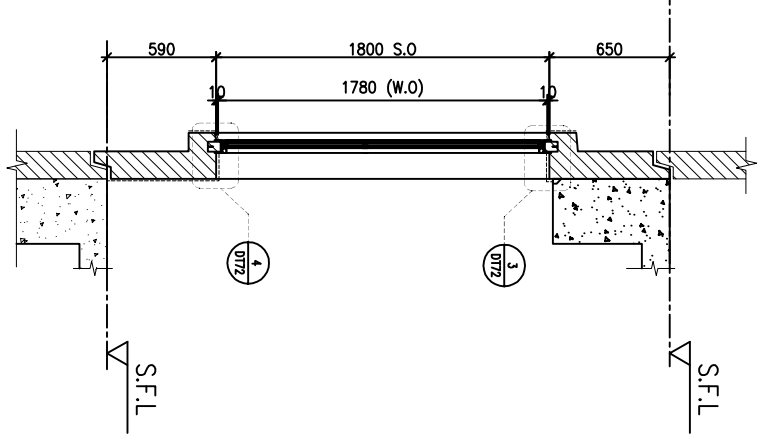
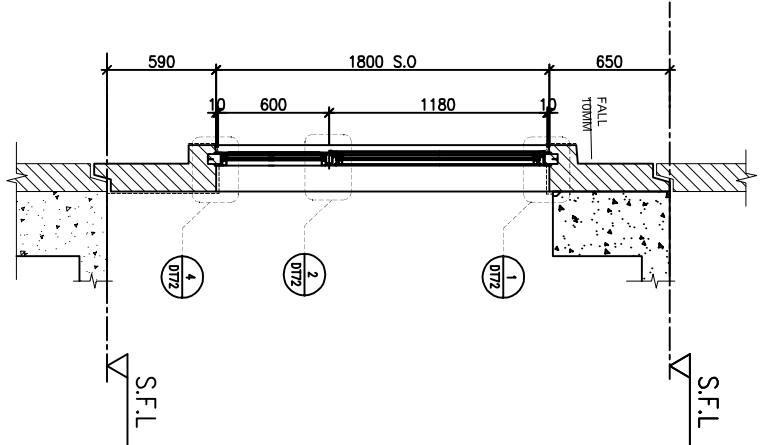
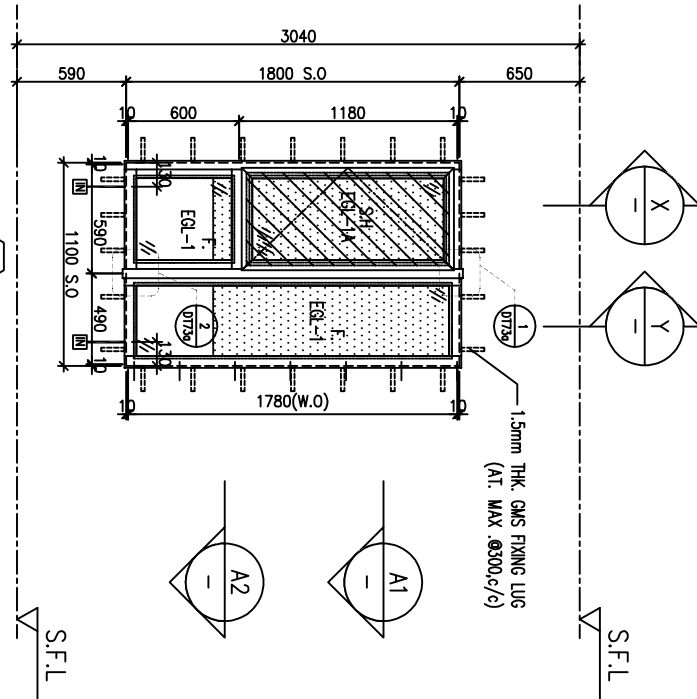

NOTE:

1. ALL DIMENSIONS ARE IN mm.
2. ALL ELEVATIONS ARE VIEWED FROM OUTSIDE.
3. ALL DIMENSIONS TO BE VERIFIED ON SITE BEFORE FABRICATION.

LEGEND:

- (X1) --- DETAIL MARK NO.
- (X200) --- REEFER SHEET NO.
- 1. F.F.L. --- FINISHED FLOOR LEVEL
- 2. S.F.L. --- STRUCTURAL FLOOR LEVEL
- 3. (R) --- REVERSED DETAIL

4. GLASS LEGEND
- EQ1-1 --- 8mmHS+12mm AIR GAP+10mmTP THK. I.G.U.
- EQ1-2 --- 10mm THK. CLEAR TEMPERED GLASS
- EQ1-4 --- 10mm THK. TEMPERED ACID ETCHED GLASS
- EQ1-1A --- 8mmHS+12mm AIR GAP+8mmTP THK. I.G.U.
- EQ1-1B --- 8mmHS+12mm AIR GAP+10mmTP ACID-ETCHED THK. I.G.U.

NO.	DATE	REVISION	REVISION SUBJECT TO ARCH/COMMENT	BY
G	26/10/2022	REVISION SUBJECT REFER TO SH-1324		h
F	21/09/2022	REVISION SUBJECT TO ARCH/COMMENT		h
E	17/08/2022	REVISION SUBJECT TO ARCH/COMMENT		h
D	06/07/2022	REVISION SUBJECT TO ARCH/COMMENT		h
C	17/12/2021	REVISION SUBJECT TO ARCH/COMMENT		h
B	29/11/2021	REVISION SUBJECT TO ARCH/COMMENT		h
A	03/11/2021	REVISION SUBJECT TO ARCH/COMMENT		h

JOB NO. : J-856
 PROJECT : PROPOSED DEVELOPMENT ABOVE LIGHT RAIL TIN WING STOP-TSWTL NO.23,AREA 33,TIN SHUI WAI, N.T.
 TITLE : WINDOW SCHEDULE FOR TOWER 1 ALUM. WINDOW

DATE : 02-Aug-21 SCALE : 1:40
 DRAWN BY : IYVN CHECKED BY :

UNITA 6-8, SUNRISE INDUSTRIAL CENTRE, 1/F
 610 Chee Kwoi Ling Road, Kowloon
 Tel:23489211-4 Fax:8522727666
 DWG NO. : 1856-SD-PW-5102 REV : G

BD. REF :

CLIENT : **SUN HUNG KAI**
 REAL ESTATE AGENCY LTD.
 42/F SUN HUNG KAI CENTRE, WANCHAI, HONGKONG

ARCHITECT : **lwk&partners**
 a r c h i t e c t s

MAIN CONTRACTOR : **怡輝建築有限公司**
 Yee Fai Building Contractors Ltd.

STRUCTURAL ENGINEER : **ARUP**

FAÇADE CONSULTANT : **ALPHA CONSULTING LIMITED**
 Steel Structure & Façade Specialist

WINDOW MARK	REQUIRE	PROVIDED
AW 02	3/F-42/F(4/F,13/F,14/F,24/F,34/F OMITTED) UNIT A2(5/F-42/F)	3/F-42/F(4/F,13/F,14/F,24/F,34/F OMITTED) UNIT A2(3/F) , B3(10/F,16/F,20/F,25/F,29/F,33/F,36/F,42/F CHANGE TO IN-SITU WINDOW)
SECTION	70mm ALUM. SECTION	70mm ALUM. SECTION
GLAZING	EGL-1,EGL-1A	EGL-1,EGL-1A
QUANTITY	34 Nos.	1 No. / (27 Nos)
REMARKS	FAÇADE(TYPE T1PF02R FOR 3/F~42/F) , 4 BAR HINGE-LIP HING (HHMS-N16)	FAÇADE(TYPE T1PF02R/ T1PF02 FOR 3/F~42/F) , 4 BAR HINGE-LIP HING (HHMS-N16)

LOCATION	OPENABLE AREA	GLAZING AREA	OPENABLE AREA	GLAZING AREA
A2-MBR	0.477	0.763	0.548	1.495

LOCATION	OPENABLE AREA	GLAZING AREA	OPENABLE AREA	GLAZING AREA
A2-BR2	0.263	0.420	0.548	0.985

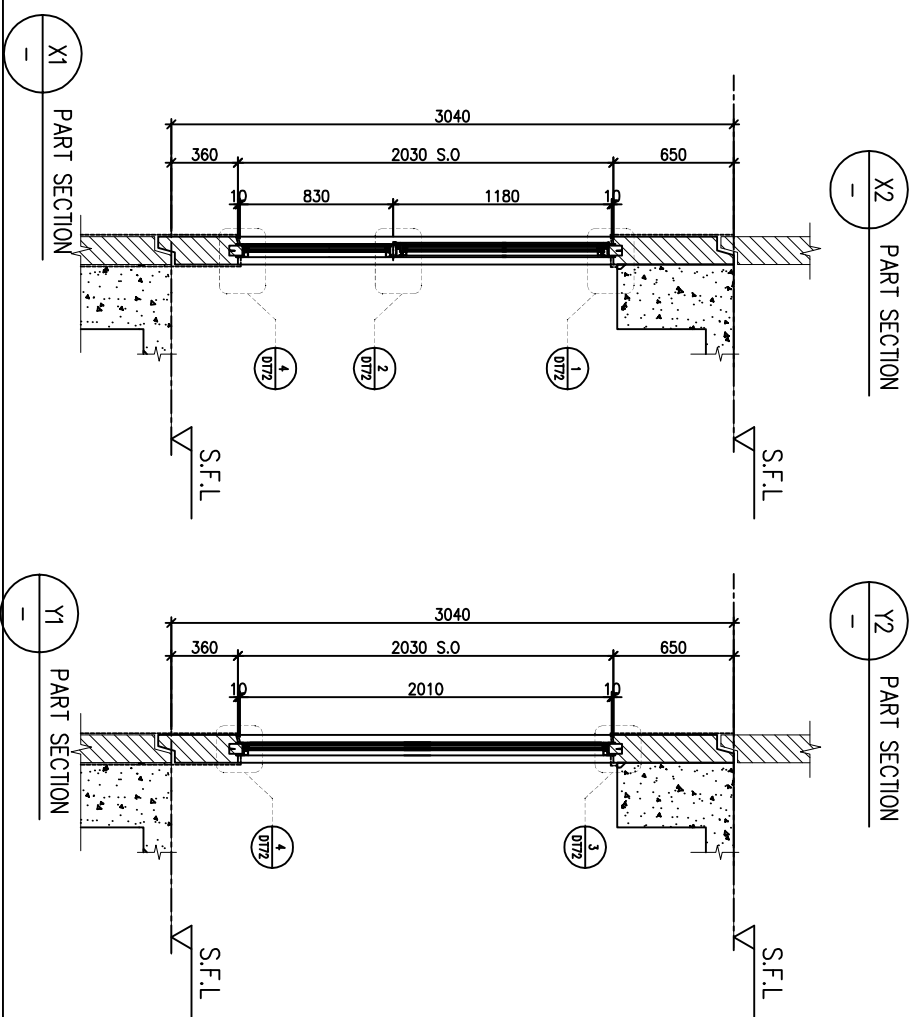
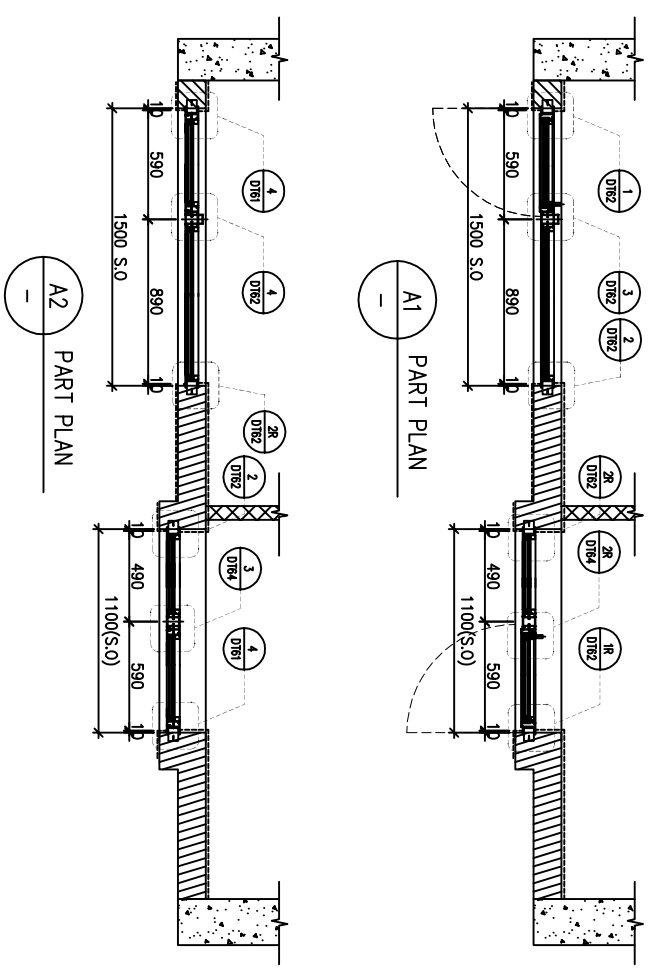
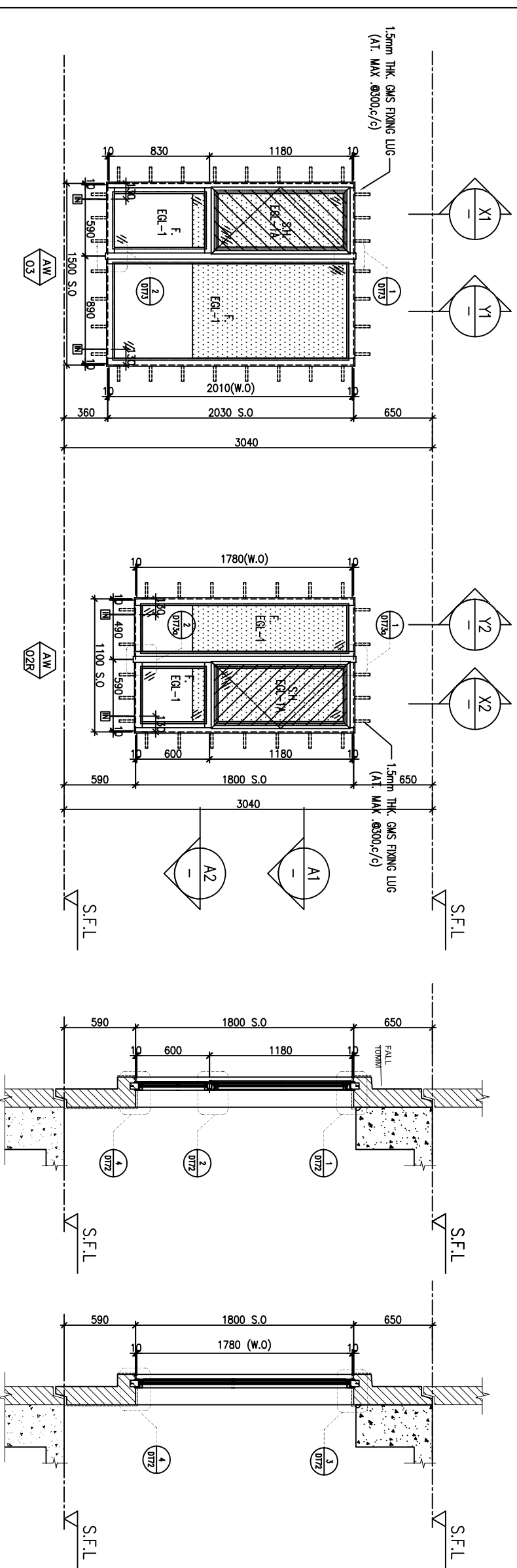

WINDOW MARK	AW 03	AW 02B
LOCATION	3/F-42/F, 13/F, 14/F, 24/F, 34/F OMITTED UNIT A2	
SECTION	70mm ALUM. SECTION	
GLAZING	EGL-1, EGL-1A	
QUANTITY	35 Nos./35 Nos.	
REMARKS	FAÇADE(TYPE T1PFO1R) FOR 3/F~42/F), 4 BAR HINGE-LIP HING (HHMS-N16)	

BD. REF :

CLIENT :
SUN HUNG KAI
 REAL ESTATE AGENCY LTD.
 42/F SUN HUNG KAI CENTRE, WANCHAI, HONGKONG

ARCHITECT :
lwk&partners
 a r c h i t e c t s

MAIN CONTRACTOR :
怡輝建築有限公司
Yee Fai
 Building Contractors Ltd.

STRUCTURAL ENGINEER :
ARUP
 ALPHA CONSULTING LIMITED
 Steel Structure & Façade Specialist

NOTE :
 1. ALL DIMENSIONS ARE IN mm.
 2. ALL ELEVATIONS ARE VIEWED FROM OUTSIDE.
 3. ALL DIMENSIONS TO BE VERIFIED ON SITE BEFORE FABRICATION.

LEGEND :
 X1 --- DETAIL MARK NO.
 X2001 --- REEFER SHEET NO.
 1. F.F.L. --- FINISHED FLOOR LEVEL
 2. S.F.L. --- STRUCTURAL FLOOR LEVEL
 3. R --- REVERSED DETAIL
 4. GLASS LEGEND
 EQ1-1 --- 8mmHS+12mm AIR GAP+10mmTP THK. I.G.U.
 EQ1-2 --- 10mm THK. CLEAR TEMPERED GLASS
 EQ1-4 --- 10mm THK. TEMPERED ACID ETCHED GLASS
 EQ1-1A --- 8mmHS+12mm AIR GAP+8mmTP THK. I.G.U.
 EQ1-1B --- 8mmHS+12mm AIR GAP+10mmTP THK. I.G.U.
 10mmTP ACID-ETCHED THK. I.G.U.

NO.	DATE	REVISION	BY
F	21/09/2022	REVISION SUBJECT TO ARCH/COMMENT	HW
E	17/08/2022	REVISION SUBJECT TO ARCH/COMMENT	HW
D	06/07/2022	REVISION SUBJECT TO ARCH/COMMENT	HW
C	17/12/2021	REVISION SUBJECT TO ARCH/COMMENT	HW
B	29/11/2021	REVISION SUBJECT TO ARCH/COMMENT	HW
A	03/11/2021	REVISION SUBJECT TO ARCH/COMMENT	HW

JOB NO. : J-856
 PROJECT : PROPOSED DEVELOPMENT ABOVE LIGHT RAIL TIN WING STOP-TSWTL NO.23, AREA 33, TIN SHUI WAI, N.T.
 TITLE : WINDOW SCHEDULE FOR TOWER 1 ALUM. WINDOW

DATE : 02-Aug-21 SCALE : 1:40
 DRAWN BY : IYVN CHECKED BY :
美特鋁質有限公司
 MIDT ALUMINUM FABRICATOR LTD.
 Units 6-8, Sunray Industrial Centre, 1/F
 610 Chee Kwo Ling Road, Kwai Tsing
 Tel:23489211-4 Fax:(852)2727666
 DWG NO. : JB56-SD-PW-5103 REV : F

REQUIRED		PROVIDED		
LOCATION	OPENABLE AREA	GLAZING AREA	OPENABLE AREA	GLAZING AREA
A3-MBR	0.435	0.696	0.548	1.24
B2-MBR	0.435	0.696		

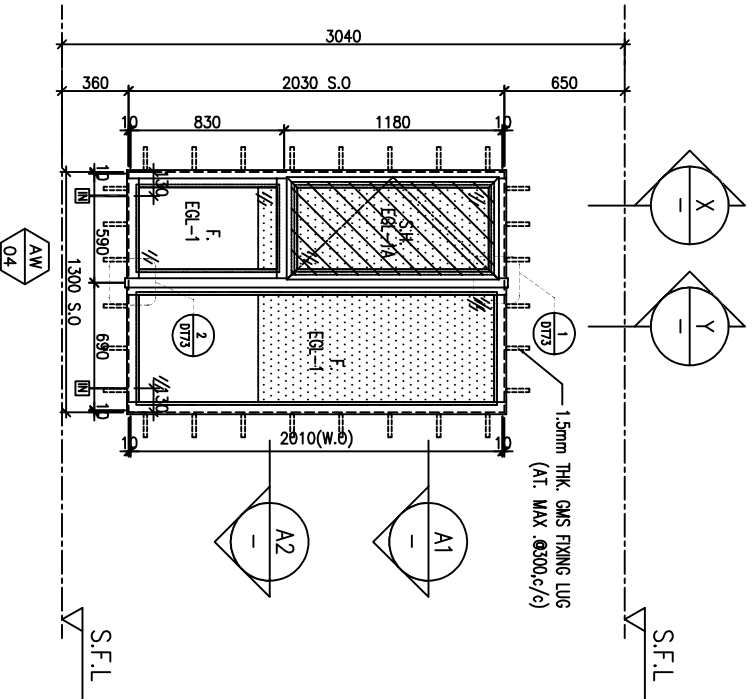

ELEVATION

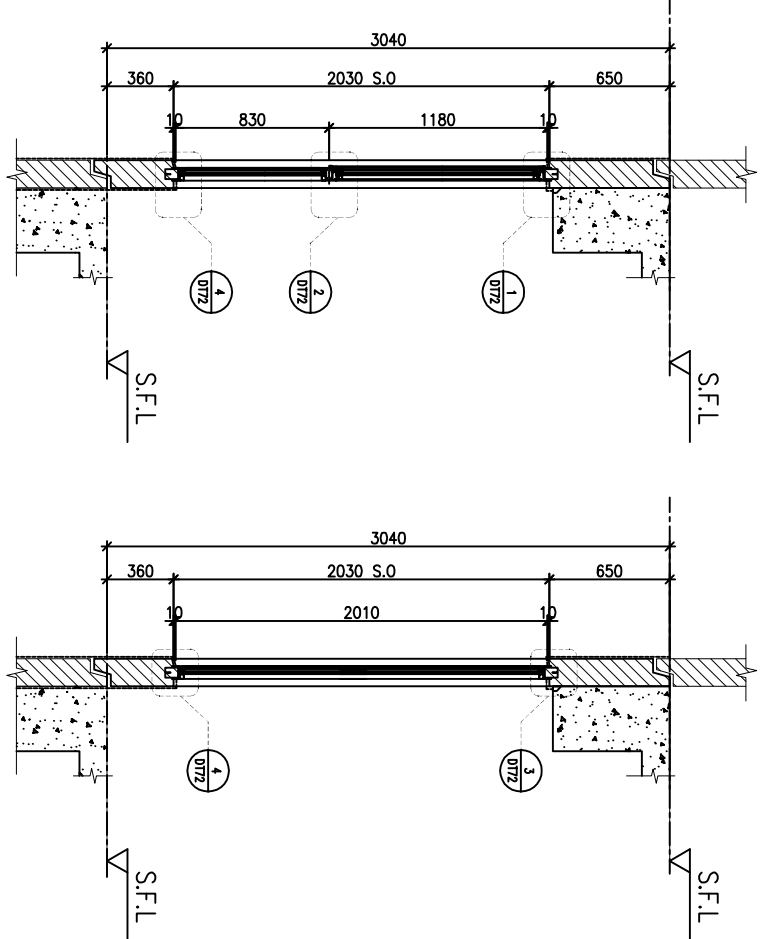
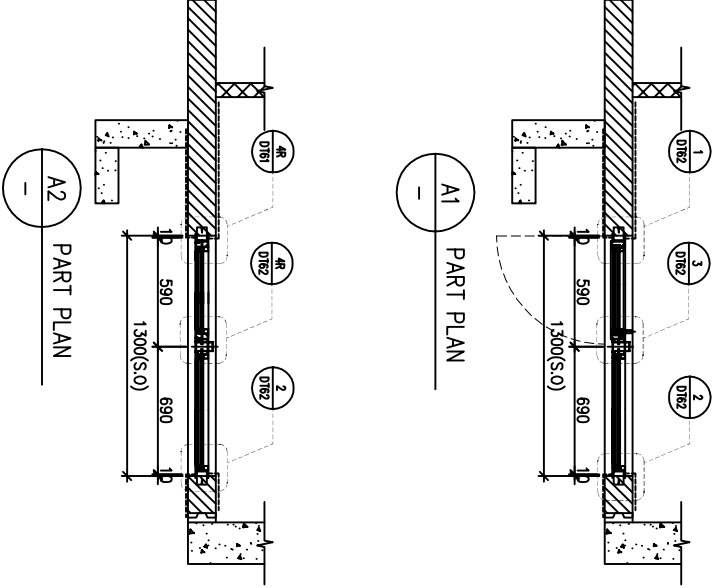

WINDOW MARK	SECTION	LOCATION	REMARKS
AW 04	70mm ALUM. SECTION	3/F-42/F(4/F,13/F,14/F,24/F,34/F OMITTED) UNIT B2,A3	FACADE(TYPE T1PF03R FOR 3/F~42/F) ,4 BAR HINGE-LIP HING (HHMS-N16)
AW 04R	70mm ALUM. SECTION	3/F-42/F(4/F,13/F,14/F,24/F,34/F OMITTED) UNIT B7	FACADE(TYPE T1PF04 FOR 3/F~42/F)
AW 04	70mm ALUM. SECTION	3/F-42/F(4/F,13/F,14/F,24/F,34/F OMITTED) UNIT B7	FACADE(TYPE T1PF04 FOR 3/F~42/F)

BD. REF :

CLIENT :
SUN HUNG KAI
 REAL ESTATE AGENCY LTD.
 42/F SUN HUNG KAI CENTRE, WANCHAI, HONGKONG

ARCHITECT :
lwk&partners
 A R C H I T E C T S

MAIN CONTRACTOR :
怡輝建築有限公司
 Yee Fai Building Contractors Ltd.

STRUCTURAL ENGINEER :
ARUP

FAÇADE CONSULTANT:
ALPHA CONSULTING LIMITED
 Steel Structure & Façade Specialist

NOTE:
 1. ALL DIMENSIONS ARE IN mm.
 2. ALL ELEVATIONS ARE VIEWED FROM OUTSIDE.
 3. ALL DIMENSIONS TO BE VERIFIED ON SITE BEFORE FABRICATION.

LEGEND:
 X1 --- DETAIL MARK NO.
 X2001 --- REEFER SHEET NO.

1. F.F.L. --- FINISHED FLOOR LEVEL
 2. S.F.L. --- STRUCTURAL FLOOR LEVEL
 3. (R) --- REVERSED DETAIL

4. GLASS LEGEND
 EQ-1-1 --- 8mmHS+12mm AIR GAP+10mmTP THK. IGLU.
 EQ-2-2 --- 10mm THK. CLEAR TEMPERED GLASS
 EQ-3-4 --- 10mm THK. TEMPERED ACID ETCHED GLASS
 EQ-1A-8mmHS+12mm AIR GAP+8mmTP THK. IGLU.
 EQ-1B-8mmHS+12mm AIR GAP+10mmTP THK. IGLU.
 EQ-1C-10mmTP THK. IGLU.

NO.	DATE	REVISION	REVISION SUBJECT TO ARCH/COMMENT	BY
G	21/09/2022	REVISION SUBJECT TO ARCH/COMMENT	hwn	
F	17/09/2022	REVISION SUBJECT TO ARCH/COMMENT	hwn	
E	09/07/2022	REVISION SUBJECT TO ARCH/COMMENT	hwn	
D	17/12/2021	REVISION SUBJECT TO ARCH/COMMENT	hwn	
C	29/11/2021	REVISION SUBJECT TO ARCH/COMMENT	hwn	
B	03/11/2021	REVISION SUBJECT TO ARCH/COMMENT	hwn	
A	12/10/2021	REVISION SUBJECT TO ARCH/COMMENT	hwn	

JOB NO. : J-856
 PROJECT : PROPOSED DEVELOPMENT ABOVE LIGHT RAIL TIN WING STOP,TSWTL NO.23,AREA 33,TIN SHUI WAI, N.T.
 TITLE : WINDOW SCHEDULE FOR TOWER 1 ALUM. WINDOW

DATE : 02-Aug-21
 SCALE : 1:40
 DRAWN BY : Ivnv
 CHECKED BY :

美特鋁質有限公司
 MIDT ALUMINUM FABRICATOR LTD.
 Units 6-8, Sunray Industrial Centre, 1/F
 610 Cheung Kwong Road, Kwai Tsouk
 Tel:23492111-4 Fax:(852)27272666
 DWG NO. : JB56-SD-PW-5104 REV : G

DELETE

REQUIRED		PROVIDED		
LOCATION	OPENABLE AREA	GLAZING AREA	OPENABLE AREA	GLAZING AREA
A3-BR1	0.263	0.420	0.548	0.985
B2-BR1	0.263	0.420		

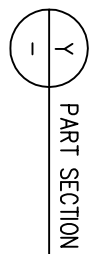
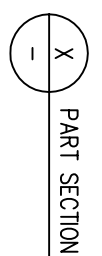
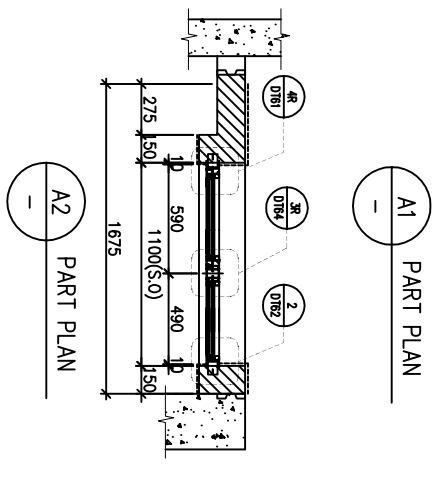
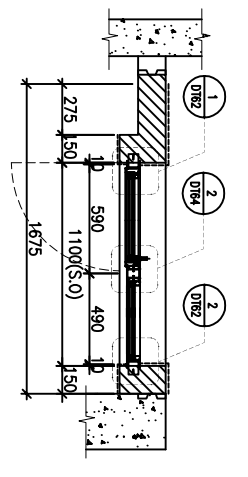
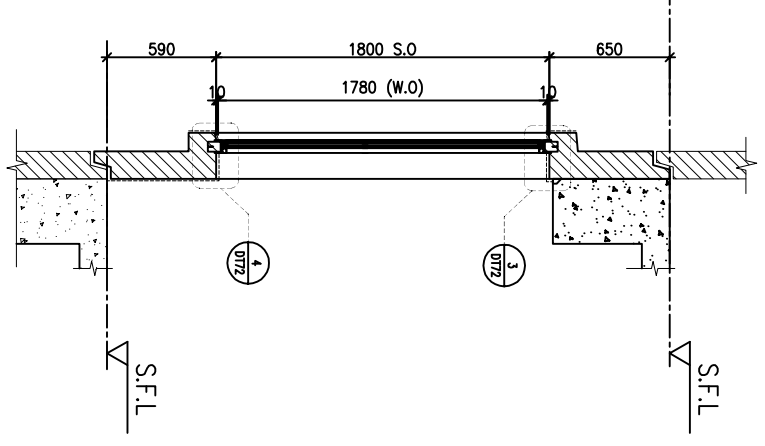
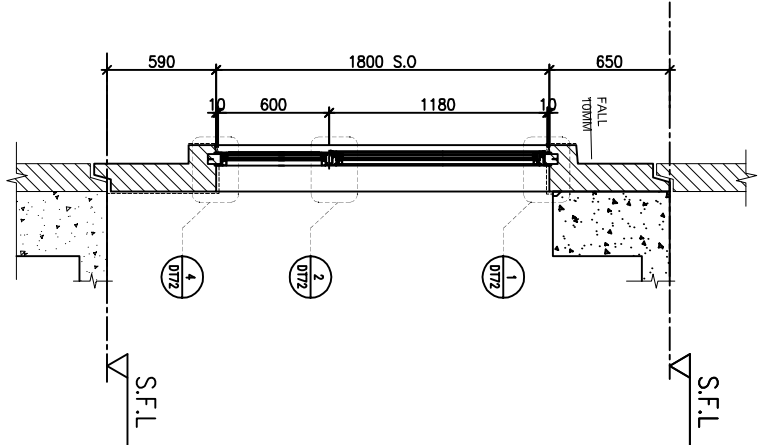
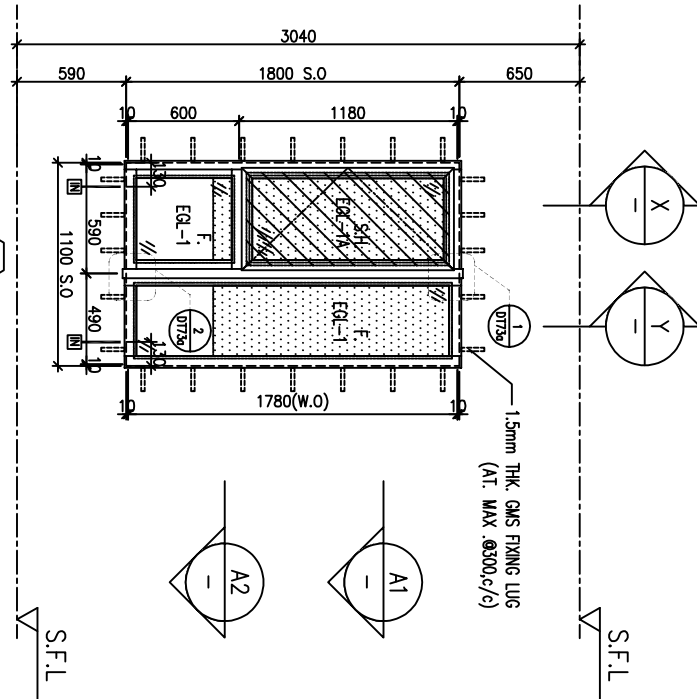

WINDOW MARK	REMARKS	WINDOW MARK	REMARKS
AW 02	3/F-42/F(4/F,13/F,14/F,24/F,34/F OMITTED) UNIT B2 (10/F,16/F,20/F,25/F,29/F,33/F,38/F,42/F CHANGE TO IN-SITU WINDOW)	AW 02R	3/F-42/F(4/F,13/F,14/F,24/F,34/F OMITTED) UNIT A3
SECTION	70mm ALUM. SECTION	SECTION	70mm ALUM. SECTION
GLAZING	EGL-1,EGL-1A	GLAZING	EGL-1,EGL-1A
QUANTITY	{27 Nos}	QUANTITY	35 Nos
REMARKS	FACADE(TYPE T1PF05 FOR 3/F~42/F) ,4 BAR HINGE-LIP HING (HHMS-N16)	REMARKS	FACADE(TYPE T1PF05 FOR 3/F~42/F) ,4 BAR HINGE-LIP HING (HHMS-N16)

BD. REF :

CLIENT :



MANU CONTRACTOR :
Yee Fai 怡輝建築有限公司
 Building Contractors Ltd.

STRUCTURAL ENGINEER :
ARUP

FAÇADE CONSULTANT:
ALPHA CONSULTING LIMITED
 Steel Structure & Façade Specialist

- NOTE:
1. ALL DIMENSIONS ARE IN mm.
 2. ALL ELEVATIONS ARE VIEWED FROM OUTSIDE.
 3. ALL DIMENSIONS TO BE VERIFIED ON SITE BEFORE FABRICATION.
- LEGEND:
- (X1) --- DETAIL MARK NO.
 - (X001) --- REEFER SHEET NO.

1. F.F.L. --- FINISHED FLOOR LEVEL
 2. S.F.L. --- STRUCTURAL FLOOR LEVEL
 3. (R) --- REVERSED DETAIL
4. GLASS LEGEND

EGL-1 --- 8mmHS+12mm AIR GAP+10mmTP THK. I.G.U.
 EGL-2 --- 10mm THK. CLEAR TEMPERED GLASS
 EGL-4 --- 10mm THK. TEMPERED ACID ETCHED GLASS
 EGL-1A --- 8mmHS+12mm AIR GAP+8mmTP THK. I.G.U.
 EGL-1B --- 8mmHS+12mm AIR GAP+10mmTP ACID-ETCHED THK. I.G.U.

NO.	DATE	REVISION	REVISION SUBJECT TO ARCH/COMMENT	BY
G	26/10/2022	REVISION SUBJECT REEFER TO SH-1324 (1)		
F	17/08/2022	REVISION SUBJECT TO ARCH/COMMENT		
E	17/08/2022	REVISION SUBJECT TO ARCH/COMMENT		
D	06/07/2022	REVISION SUBJECT TO ARCH/COMMENT		
C	17/12/2021	REVISION SUBJECT TO ARCH/COMMENT		
B	29/11/2021	REVISION SUBJECT TO ARCH/COMMENT		
A	03/11/2021	REVISION SUBJECT TO ARCH/COMMENT		

JOB NO. : J-856
 PROJECT : PROPOSED DEVELOPMENT ABOVE LIGHT RAIL TIN WING STOP-TSWTL NO.23,AREA 33,TIN SHUI WAI, N.T.
 TITLE : WINDOW SCHEDULE FOR TOWER 1 ALUM. WINDOW

DATE : 02-Aug-21 SCALE : 1:40
 DRAWN BY : Ivan CHECKED BY :
美特铝质有限公司
 MIDT ALUMINIUM FABRICATOR LTD.
 Units 6-8, Sunray Industrial Centre, 1/F
 610 Chee Kwo Ling Road, Kwai Tsoung
 Tel:23489211-4 Fax:6527272666
 DWG NO. : 1856-SD-PW-5105 REV : G

REQUIRE		PROVIDED	
LOCATION	OPENABLE AREA	GLAZING AREA	OPENABLE AREA
B3-MBR	0.427	0.763	0.548
			GLAZING AREA
			1.495

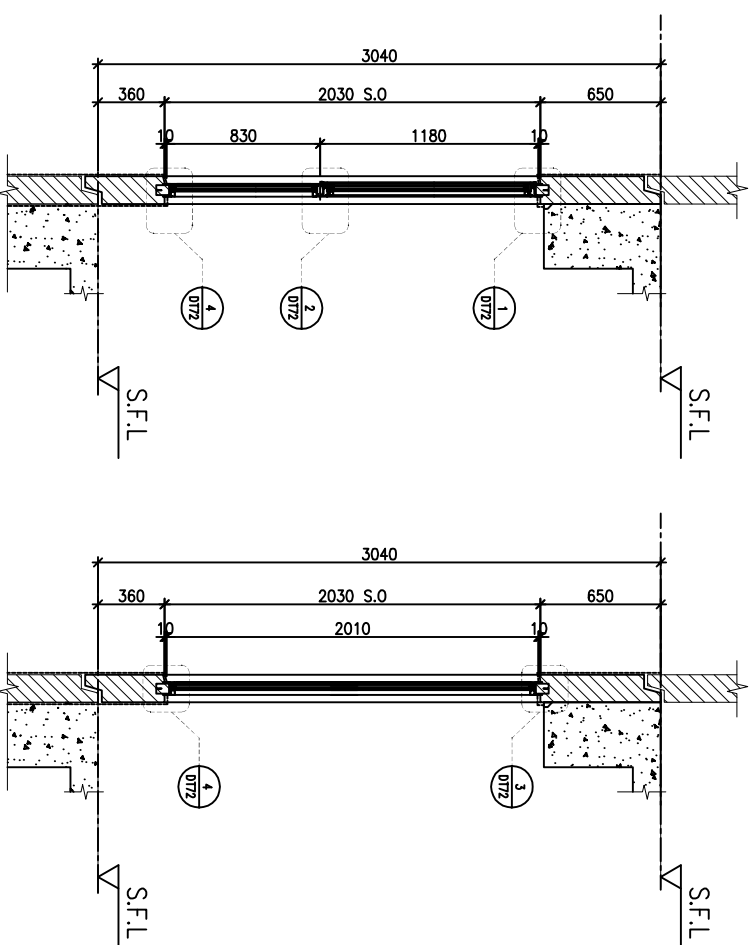
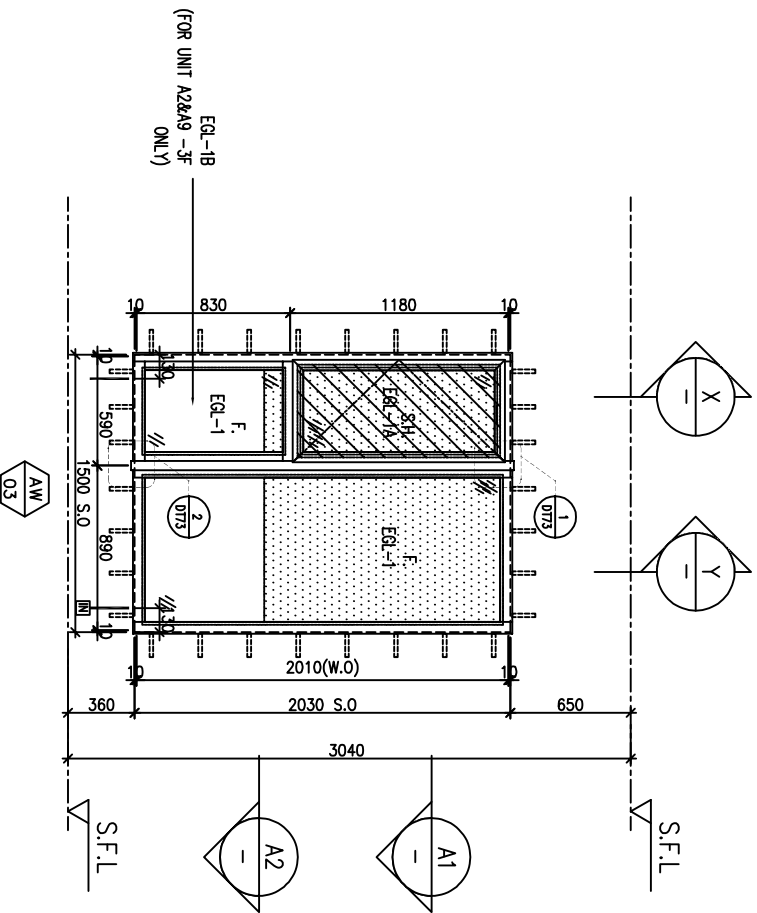

ELEVATION

A1 PART PLAN

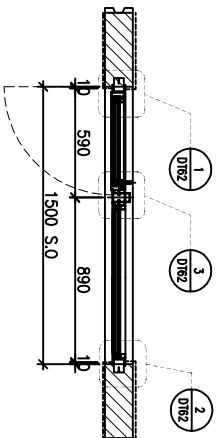

A2 PART PLAN

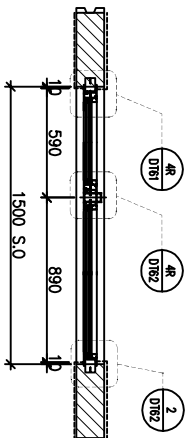

WINDOW MARK	A/W 03
LOCATION	3/F-42/F(4/F,13/F,14/F,24/F,34/F OMITTED) UNIT B3
SECTION	70mm ALUM. SECTION
GLAZING	EGL-1, EGL-1A
QUANTITY	35 Nos
REMARKS	FAÇADE(TYPE T1PF07R FOR 3/F~42/F) , 4 BAR HINGE-LIP HING (HHMS-N16)

B.D. REF :

CLIENT :

SUN HUNG KAI
REAL ESTATE AGENCY LTD.
42/F SUN HUNG KAI CENTRE, WANCHAI, HONGKONG

ARCHITECT :

lwk&partners
ARCHITECTS

MAIN CONTRACTOR :

Yee Fai 怡輝建築有限公司
Building Contractors Ltd.

STRUCTURAL ENGINEER :

ARUP

FAÇADE CONSULTANT:

ALPHA CONSULTING LIMITED
Steel Structure & Façade Specialist

- NOTE :
1. ALL DIMENSIONS ARE IN mm.
 2. ALL ELEVATIONS ARE VIEWED FROM OUTSIDE.
 3. ALL DIMENSIONS TO BE VERIFIED ON SITE BEFORE FABRICATION.

LEGEND :

- (X1) --- DETAIL MARK NO.
(X001) --- REFER SHEET NO.
1. F.F.L. --- FINISHED FLOOR LEVEL
 2. S.F.L. --- STRUCTURAL FLOOR LEVEL
 3. (R) --- REVERSED DETAIL

4. GLASS LEGEND

- EQI-1 --- 8mmHS+12mm AIR GAP+10mmTP THK. I.G.U.
EQI-2 --- 10mm THK. CLEAR TEMPERED GLASS
EQI-4 --- 10mm THK. TEMPERED ACID ETCHED GLASS
EQI-1A --- 8mmHS+12mm AIR GAP+8mmTP THK. I.G.U.
EQI-1B --- 8mmHS+12mm AIR GAP+10mmTP ACID-ETCHED THK. I.G.U.

NO.	DATE	REVISION	REVISION SUBJECT TO ARCH/COMMENT	BY
H	21/09/2022	REVISION SUBJECT TO ARCH/COMMENT		HW
G	17/08/2022	REVISION SUBJECT TO ARCH/COMMENT		HW
F	06/07/2022	REVISION SUBJECT TO ARCH/COMMENT		HW
E	17/12/2021	REVISION SUBJECT TO ARCH/COMMENT		HW
D	17/12/2021	REVISION SUBJECT TO ARCH/COMMENT		HW
C	29/11/2021	REVISION SUBJECT TO ARCH/COMMENT		HW

JOB NO. : J-856

PROJECT : PROPOSED DEVELOPMENT ABOVE LIGHT RAIL TIN WING STOP TSWTL NO.23,AREA 33,TIN SHUI WAI, N.T.

TITLE : WINDOW SCHEDULE FOR TOWER 1 ALUM. WINDOW

DATE : 02-Aug-21

SCALE : 1:40

DRAWN BY : IYVN

CHECKED BY :

美特铝质有限公司
MIDI ALUMINUM FABRICATOR LTD.
Units 6-8, Sunray Industrial Centre, 1/F
610 Cheong Kwai Ling Road, Kwai Tsoum
Tel:23489211-4 Fax:(852)2727666

DWG NO. : JB56-SD-PW-5106 REV : H

REQUIRE		PROVIDED	
LOCATION	OPENABLE AREA	GLAZING AREA	OPENABLE AREA
B8-BR1	0.263	0.420	0.439
			GLAZING AREA
			1.19

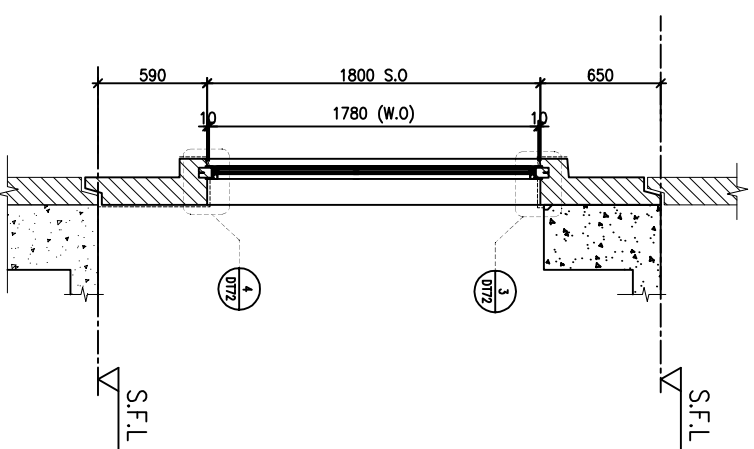
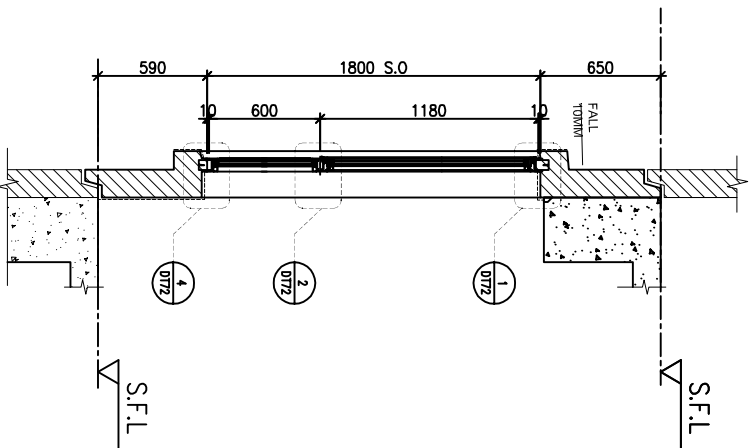
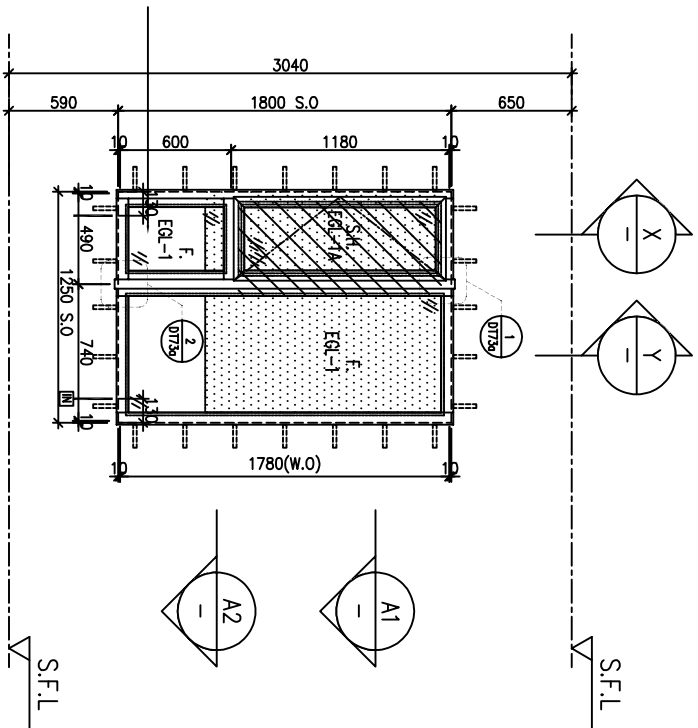

ELEVATION

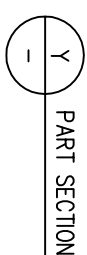
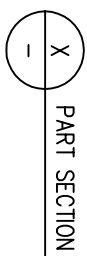
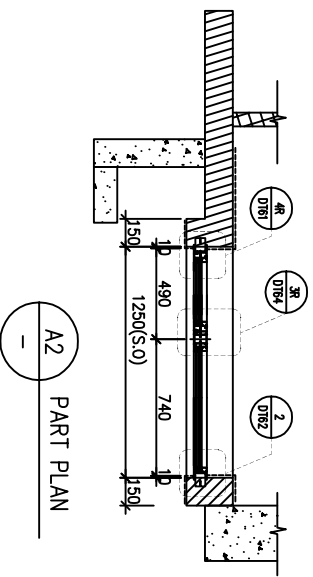
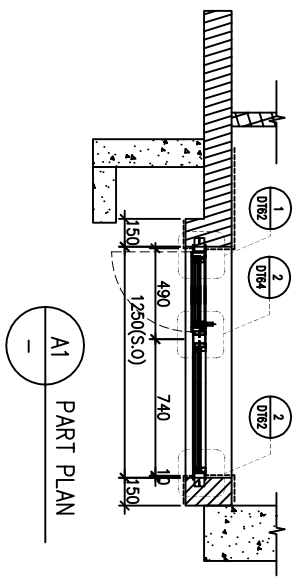

WINDOW MARK	REVISION	DESCRIPTION
AW 02d		
AW 02R		

LOCATION	SECTION	QUANTITY	REMARKS
3/F-42/F(4/F,13/F,14/F,24/F,34/F OMITTED) UNIT B8	70mm ALUM. SECTION	35 Nos	FACADE(TYPE T1PF04R FOR 3/F~42/F) ,4 BAR HINGE-LIP HING (HHMS-N16)
3/F-42/F(4/F,13/F,14/F,24/F,34/F OMITTED) UNIT A8,B1	70mm ALUM. SECTION	35 Nos	FACADE(TYPE T1PF08 FOR 3/F~42/F)

DEVELOP

BD. REF :

CLIENT :

SUN HUNG KAI
REAL ESTATE AGENCY LTD.
42/F SUN HUNG KAI CENTRE, WANCHAI, HONGKONG

ARCHITECT :

lwk&partners
ARCHITECTS

MAIN CONTRACTOR :

Yee Fai
Building Contractors Ltd.

STRUCTURAL ENGINEER :

ARUP

FAÇADE CONSULTANT :

ALPHA CONSULTING LIMITED
Steel Structure & Façade Specialist

NOTE :

1. ALL DIMENSIONS ARE IN mm.
2. ALL ELEVATIONS ARE VIEWED FROM OUTSIDE.
3. ALL DIMENSIONS TO BE VERIFIED ON SITE BEFORE FABRICATION.

LEGEND :

- (X1) --- DETAIL MARK NO.
- (X001) --- REFER SHEET NO.
- 1. F.F.L. --- FINISHED FLOOR LEVEL
- 2. S.F.L. --- STRUCTURAL FLOOR LEVEL
- 3. (R) --- REVERSED DETAIL

4. GLASS LEGEND

- EQ1-1 --- 8mmHS+12mm AIR GAP+10mmTP THK. I.G.U.
- EQ1-2 --- 10mm THK. CLEAR TEMPERED GLASS
- EQ1-4 --- 10mm THK. TEMPERED ACID ETCHED GLASS
- EQ1-1A --- 8mmHS+12mm AIR GAP+8mmTP THK. I.G.U.
- EQ1-1B --- 8mmHS+12mm AIR GAP+10mmTP ACID-ETCHED THK. I.G.U.

NO.	DATE	REVISION	BY
F	17/06/2022	REVISION SUBJECT TO ARCH/COMMENT	HW
E	17/06/2022	REVISION SUBJECT TO ARCH/COMMENT	HW
D	06/07/2022	REVISION SUBJECT TO ARCH/COMMENT	HW
C	17/12/2021	REVISION SUBJECT TO ARCH/COMMENT	HW
B	29/11/2021	REVISION SUBJECT TO ARCH/COMMENT	HW
A	03/11/2021	REVISION SUBJECT TO ARCH/COMMENT	HW

JOB NO. : J-856

PROJECT :

PROPOSED DEVELOPMENT ABOVE LIGHT RAIL TIN WING STOP/TSWTL NO.23,AREA 33,TIN SHUI WAI, N.T.

TITLE :

WINDOW SCHEDULE FOR TOWER 1 ALUM. WINDOW

DATE : 02-Aug-21 SCALE : 1:40

DRAWN BY : IYVN CHECKED BY :

美特铝质有限公司
MIDI ALUMINIUM FABRICATOR LTD.
Units 6-8, Sunray Industrial Centre, 1/F
610 Chee Kwo Ling Road, Kwai Tsing, N.T.
Tel:23489211-4 Fax:(852)2727666

DWG NO. : 1856-SD-PW-5107 REV. : F

REQUIRE		PROVIDED	
LOCATION	OPENABLE AREA	GLAZING AREA	OPENABLE AREA
B3-KIT	0.251	0.401	0.549
			GLAZING AREA
			0.456

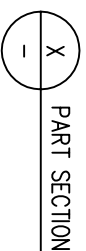
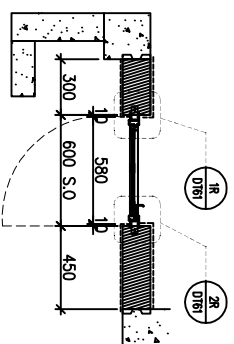
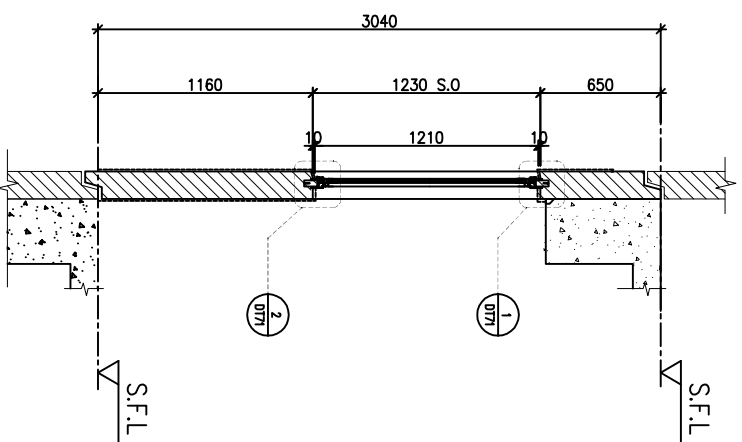
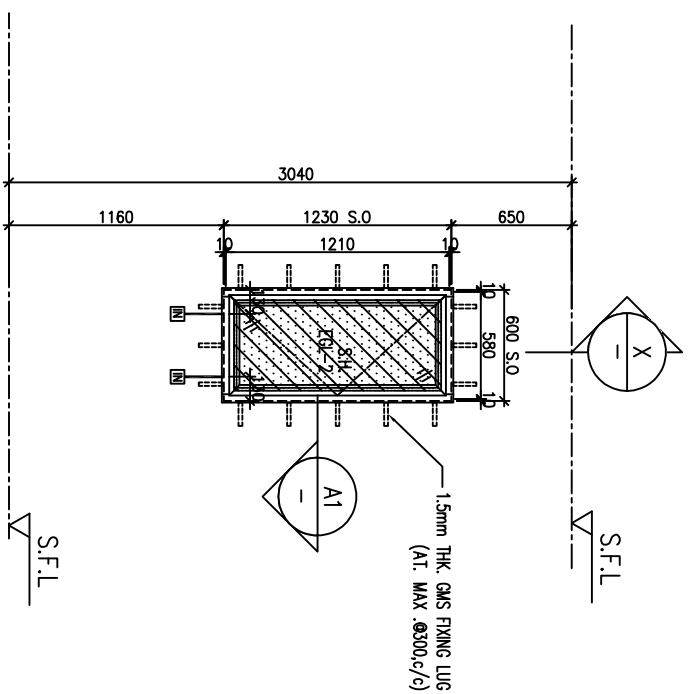

ELEVATION

WINDOW MARK	AM	OSBR
LOCATION	3/F-42/F(4/F,13/F,14/F,24/F,34/F OMITTED) UNIT B3	
SECTION	50mm ALUM. SECTION	
GLAZING	EGL-2	
QUANTITY	35 Nos	
REMARKS	FACADE(TYPE TYPFOR FOR 3/F~42/F) ,4 BAR HINGE-LIP HING (HHMS-N16)	

B.D. REF :

CLIENT :

SUN HUNG KAI
REAL ESTATE AGENCY LTD.
42/F SUN HUNG KAI CENTRE, WANCHAI, HONGKONG

ARCHITECT :

lwk&partners
a r c h i t e c t s

MAIN CONTRACTOR :

Yee Fai
Building Contractors Ltd.

STRUCTURAL ENGINEER :

ARUP

FAÇADE CONSULTANT:

ALPHA CONSULTING LIMITED
Steel Structure & Façade Specialist

NOTE :

1. ALL DIMENSIONS ARE IN mm.
2. ALL ELEVATIONS ARE VIEWED FROM OUTSIDE.
3. ALL DIMENSIONS TO BE VERIFIED ON SITE BEFORE FABRICATION.

LEGEND :

⊗ X1 --- DETAIL MARK NO.
⊗ X2001 --- REEFER SHEET NO.

1. F.F.L. --- FINISHED FLOOR LEVEL
2. S.F.L. --- STRUCTURAL FLOOR LEVEL
3. Ⓡ --- REVERSED DETAIL

4. GLASS LEGEND

- EGL-1 --- 8mmHS+12mm AIR GAP+10mmTP THK. I.G.U.
- EGL-2 --- 10mm THK. CLEAR TEMPERED GLASS
- EGL-4 --- 10mm THK. TEMPERED ACID ETCHED GLASS
- EGL-1A --- 8mmHS+12mm AIR GAP+8mmTP THK. I.G.U.
- EGL-1B --- 8mmHS+12mm AIR GAP+10mmTP ACID-ETCHED THK. I.G.U.

NO.	DATE	REVISION	BY
F	21/09/2022	REVISION SUBJECT TO ARCH/COMMENT	hwn
E	17/08/2022	REVISION SUBJECT TO ARCH/COMMENT	hwn
D	06/07/2022	REVISION SUBJECT TO ARCH/COMMENT	hwn
C	17/02/2021	REVISION SUBJECT TO ARCH/COMMENT	hwn
B	29/11/2021	REVISION SUBJECT TO ARCH/COMMENT	hwn
A	03/11/2021	REVISION SUBJECT TO ARCH/COMMENT	hwn

JOB NO. : J-856

PROJECT : PROPOSED DEVELOPMENT ABOVE LIGHT RAIL TIN WING STOP TSWTL NO.23,AREA 33,TIN SHUI WAI, N.T.

TITLE : WINDOW SCHEDULE FOR TOWER 1 ALUM. WINDOW

DATE : 02-Aug-21 SCALE : 1:40

DRAWN BY : hwn CHECKED BY :

美特铝质有限公司
MIDI ALUMINIUM FABRICATOR LTD.
Units 6-8, Sunray Industrial Centre, 1/F
610 Chee Kwo Ling Road, Kowloon
Tel:23489211-4 Fax:(852)27272666
DWG NO. : JB56-SD-PW-5108 REV : F

LOCATION	OPENABLE AREA	GLAZING AREA	OPENABLE AREA	GLAZING AREA
B6-BR1	0.263	0.420	0.439	1.19
B7-BR1	0.263	0.420		

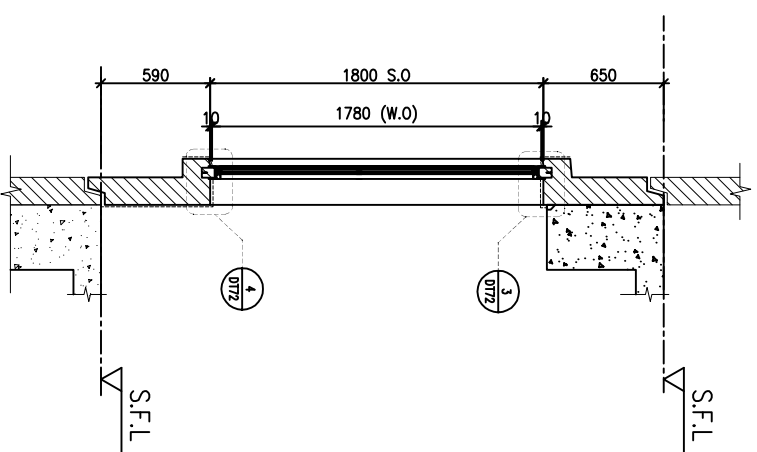
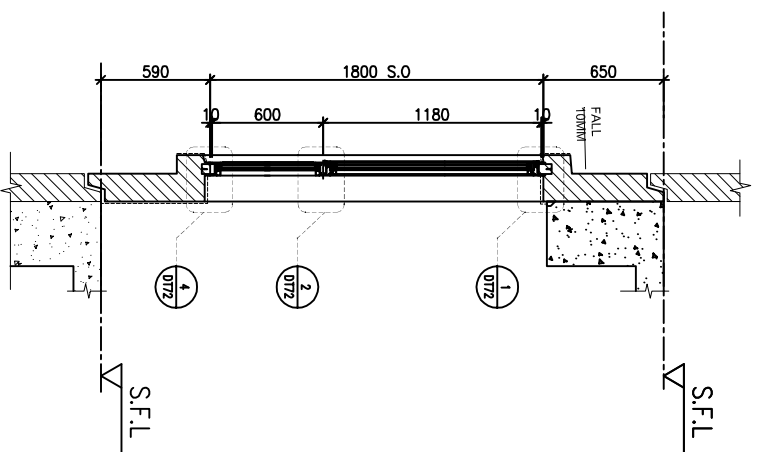
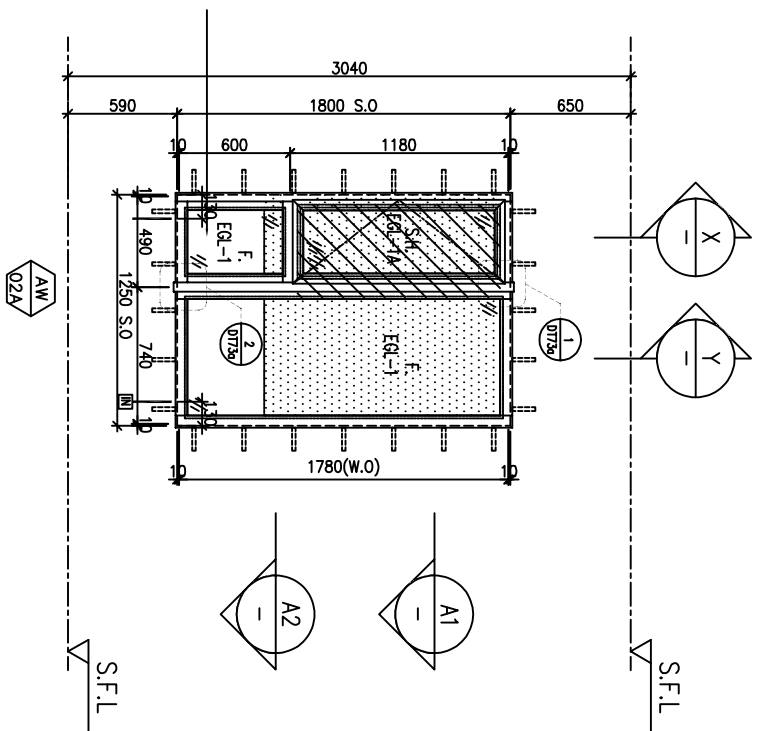

ELEVATION

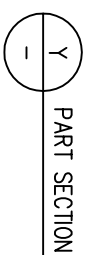
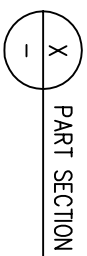
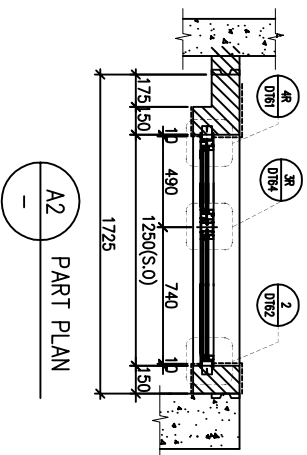
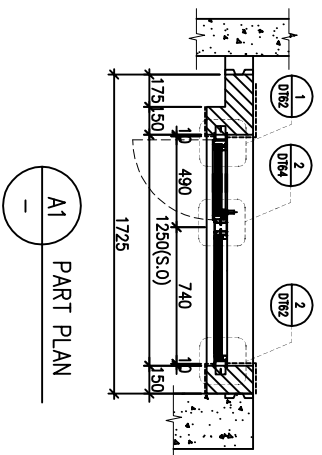

WINDOW MARK	REQUIRE	PROVIDED			
AW 02d	LOCATION	OPENABLE AREA	GLAZING AREA	OPENABLE AREA	GLAZING AREA
	B6-BR1	0.263	0.420	0.439	1.19
	B7-BR1	0.263	0.420		
LOCATION	5/F-42/F(4/F,13/F,14/F,24/F,34/F OMITTED) UNIT B7				
SECTION	70mm ALUM. SECTION				
GLAZING	EGL-1,EGL-1A				
QUANTITY	34 Nos				
REMARKS	FACADE(TYPE T1PF05R FOR 5/F~42/F) , 4 BAR HINGE-LIP HING (HHMS-N12)				
WINDOW MARK	AW 02d	AW 02d			
LOCATION	3/F UNIT B7 , 3/F UNIT B6				
SECTION	70mm ALUM. SECTION				
GLAZING	EGL-1,EGL-1A				
QUANTITY	1 No / 1 No				
REMARKS	FACADE(TYPE T1PF05R/T1PF05 FOR 3/F) , 4 BAR HINGE-LIP HING (HHMS-N12)				

BD. REF :

CLIENT :

SUN HUNG KAI
REAL ESTATE AGENCY LTD.
42/F SUN HUNG KAI CENTRE, WANCHAI, HONGKONG

ARCHITECT :

lwk&partners
ARCHITECTS

MAIN CONTRACTOR :

Yee Fai 怡輝建築有限公司
Building Contractors Ltd.

STRUCTURAL ENGINEER :

ARUP

FAÇADE CONSULTANT :

ALPHA CONSULTING LIMITED
Steel Structure & Façade Specialist

NOTE :

1. ALL DIMENSIONS ARE IN mm.
2. ALL ELEVATIONS ARE VIEWED FROM OUTSIDE.
3. ALL DIMENSIONS TO BE VERIFIED ON SITE BEFORE FABRICATION.

LEGEND :

- (X1) --- DETAIL MARK NO.
- (X001) --- REEFER SHEET NO.

1. F.F.L. --- FINISHED FLOOR LEVEL
2. S.F.L. --- STRUCTURAL FLOOR LEVEL
3. (R) --- REVERSED DETAIL

4. GLASS LEGEND

- EGL-1 --- 8mmHS+12mm AIR GAP+10mmTP THK. I.G.U.
- EGL-2 --- 10mm THK. CLEAR TEMPERED GLASS
- EGL-4 --- 10mm THK. TEMPERED ACID ETCHED GLASS
- EGL-1A --- 8mmHS+12mm AIR GAP+8mmTP THK. I.G.U.
- EGL-1B --- 8mmHS+12mm AIR GAP+10mmTP ACID-ETCHED THK. I.G.U.

NO.	DATE	REVISION	REVISION SUBJECT TO ARCH/COMMENT
G	21/09/2022	REVISION	SUBJECT TO ARCH/COMMENT
F	17/08/2022	REVISION	SUBJECT TO ARCH/COMMENT
E	06/07/2022	REVISION	SUBJECT TO ARCH/COMMENT
D	17/12/2021	REVISION	SUBJECT TO ARCH/COMMENT
C	29/11/2021	REVISION	SUBJECT TO ARCH/COMMENT
B	03/11/2021	REVISION	SUBJECT TO ARCH/COMMENT
A	12/10/2021	REVISION	SUBJECT TO ARCH/COMMENT

JOB NO. : J-856

PROJECT : PROPOSED DEVELOPMENT ABOVE LIGHT RAIL TIN WING STOP TSWTL NO.23,AREA 33,TIN SHUI WAI, N.T.

TITLE : WINDOW SCHEDULE FOR TOWER 1 ALUM. WINDOW

DATE : 02-Aug-21 SCALE : 1:40

DRAWN BY : IYVN CHECKED BY :

美特铝质有限公司
MIDI ALUMINUM FABRICATOR LTD.
Units 6-8, Sunray Industrial Centre, 1/F
610 Chee Kwo Ling Road, Kwai Tsing
Tel:23489211-4 Fax:8522727666

DWG NO. : 1856-SD-PW-5109 REV : G

REQUIRE		PROVIDED	
LOCATION	OPENABLE AREA	GLAZING AREA	OPENABLE AREA
B7-MBR	0.435	0.696	0.548
			GLAZING AREA
			1.431

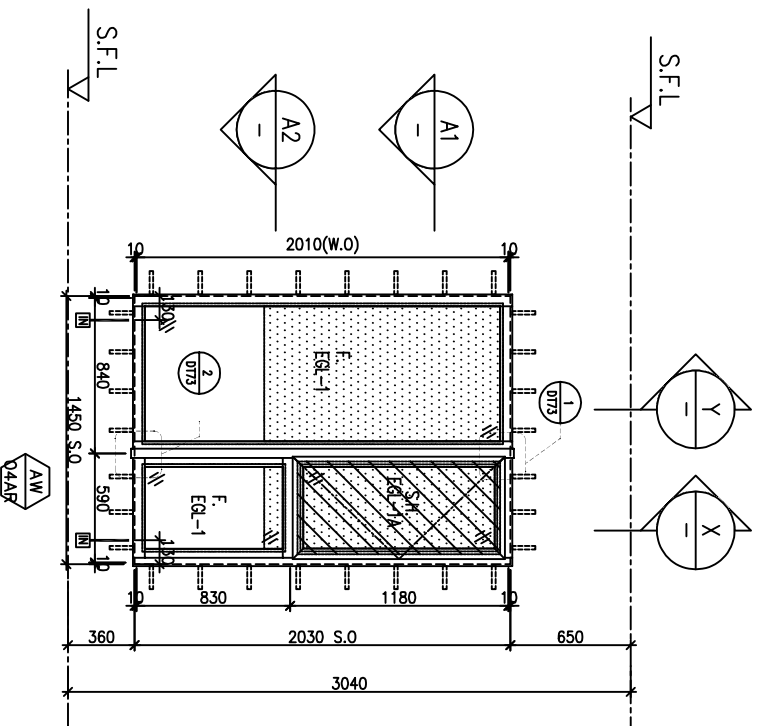

ELEVATION

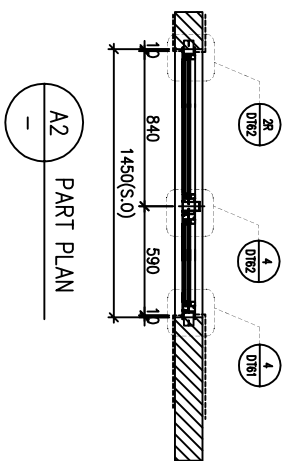
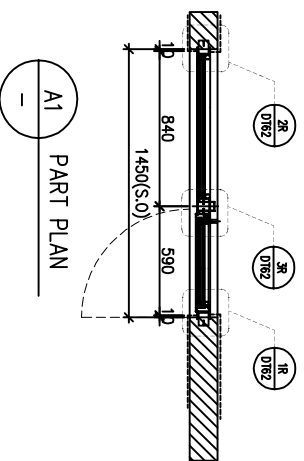
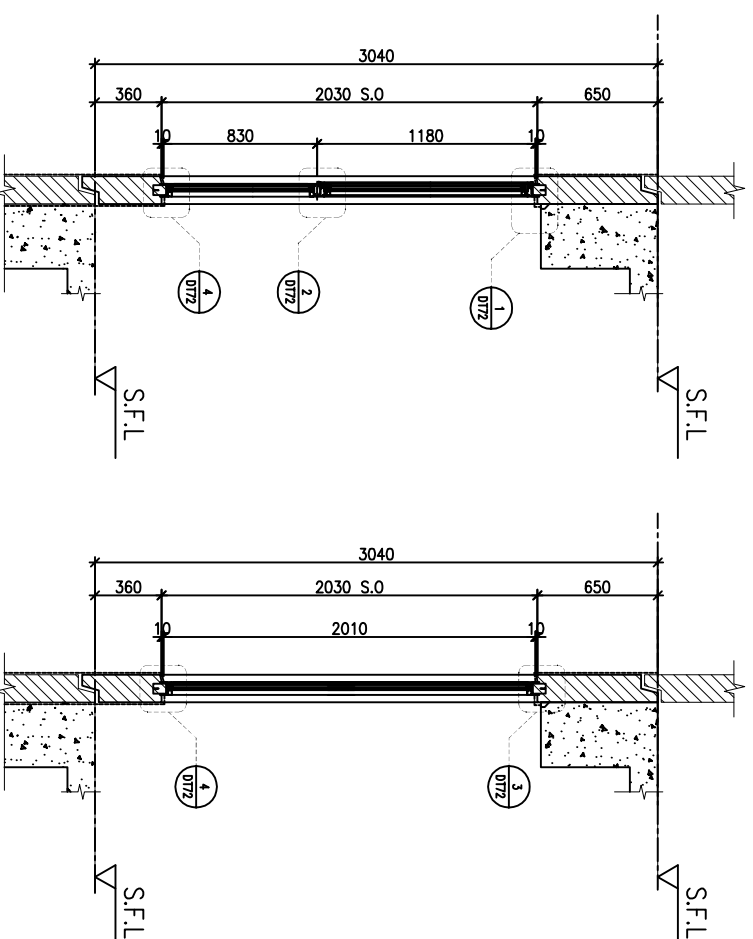

WINDOW MARK	AW 04AB
LOCATION	3/F-42/F(4/F,13/F,14/F,24/F,34/F OMITTED) UNIT B7
SECTION	70mm ALUM. SECTION
GLAZING	EGL-1, EGL-1A
QUANTITY	35 Nos
REMARKS	FAÇADE(TYPE TYPFOR FOR 3/F~42/F) ,4 BAR HINGE-LIP HING (HHMS-N16)

B.D. REF :

CLIENT :

SUN HUNG KAI
REAL ESTATE AGENCY LTD.
42/F SUN HUNG KAI CENTRE, WANCHAI, HONGKONG

ARCHITECT :

lwk&partners
A R C H I T E C T S

MAIN CONTRACTOR :

怡輝建築有限公司
Yee Fai Building Contractors Ltd.

STRUCTURAL ENGINEER :

ARUP

FAÇADE CONSULTANT :

ALPHA CONSULTING LIMITED
Steel Structure & Façade Specialist

NOTE:
1. ALL DIMENSIONS ARE IN mm.
2. ALL ELEVATIONS ARE VIEWED FROM OUTSIDE.
3. ALL DIMENSIONS TO BE VERIFIED ON SITE BEFORE FABRICATION.

LEGEND :

- (X1) --- DETAIL MARK NO.
- (X001) --- REEFER SHEET NO.
- 1. F.F.L. --- FINISHED FLOOR LEVEL
- 2. S.F.L. --- STRUCTURAL FLOOR LEVEL
- 3. (R) --- REVERSED DETAIL
- 4. GLASS LEGEND

EGL-1 --- 8mmHS+12mm AIR GAP+10mmTP THK. I.G.U.
EGL-2 --- 10mm THK. CLEAR TEMPERED GLASS
EGL-4 --- 10mm THK. TEMPERED ACID ETCHED GLASS
EGL-1A --- 8mmHS+12mm AIR GAP+8mmTP THK. I.G.U.
EGL-1B --- 8mmHS+12mm AIR GAP+10mmTP ACID-ETCHED THK. I.G.U.

NO.	DATE	REVISION	SUBJECT TO ARCH/COMMENT	BY
G	21/09/2022	REVISION	SUBJECT TO ARCH/COMMENT	HW
F	17/08/2022	REVISION	SUBJECT TO ARCH/COMMENT	HW
E	06/07/2022	REVISION	SUBJECT TO ARCH/COMMENT	HW
D	17/12/2021	REVISION	SUBJECT TO ARCH/COMMENT	HW
C	29/11/2021	REVISION	SUBJECT TO ARCH/COMMENT	HW
B	03/11/2021	REVISION	SUBJECT TO ARCH/COMMENT	HW
A	12/10/2021	REVISION	SUBJECT TO ARCH/COMMENT	HW

JOB NO. : J-856

PROJECT : PROPOSED DEVELOPMENT ABOVE LIGHT RAIL TIN WING STOP TSWTL NO.23,AREA 33,TIN SHUI WAI, N.T.

TITLE : WINDOW SCHEDULE FOR TOWER 1 ALUM. WINDOW

DATE : 02-Aug-21 SCALE : 1:40

DRAWN BY : IYVN CHECKED BY :

美特鋁質有限公司
MIDI ALUMINUM FABRICATOR LTD.
Units 6-8, Sunray Industrial Centre, 1/F
610 Chee Kwo Ling Road, Kwai Tsoung
Tel:23489211-4 Fax:(852)2727666
DWG NO. : JB56-SD-PW-5110 REV : G

REQUIRE		PROVIDED	
LOCATION	OPENABLE AREA	GLAZING AREA	OPENABLE AREA
B8-MBR	0.474	0.759	0.525
			GLAZING AREA
			2.459

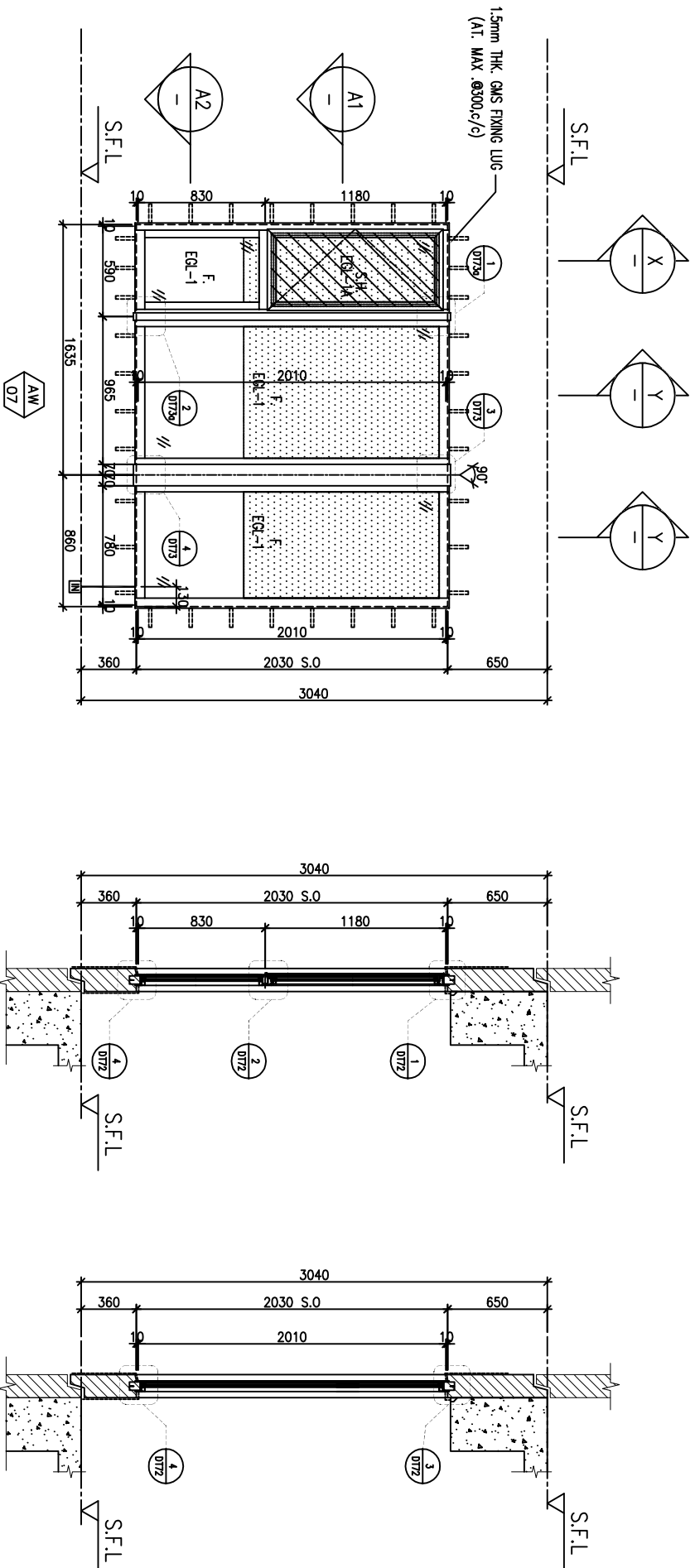

ELEVATION

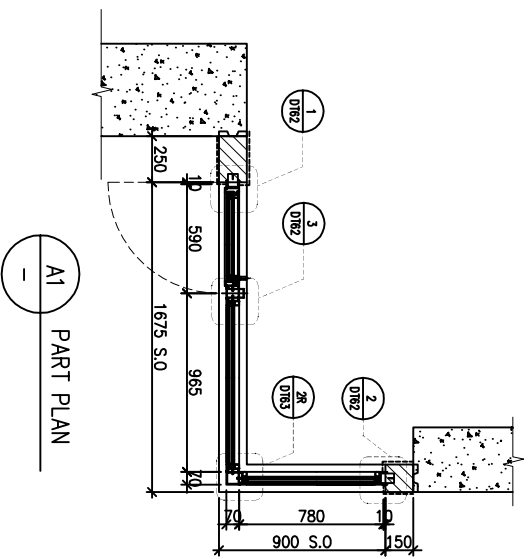

A1 PART PLAN

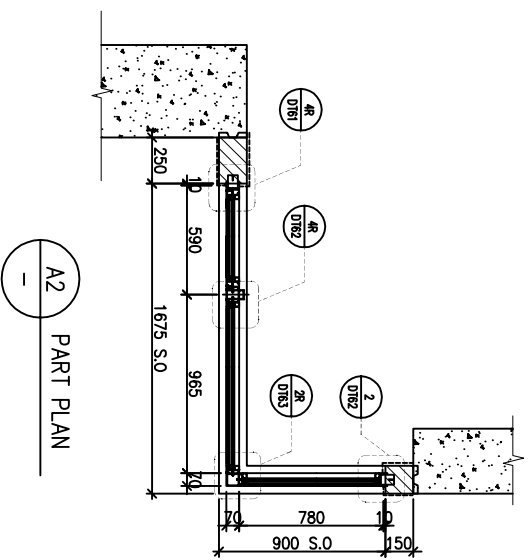

A2 PART PLAN

WINDOW MARK	AW 07
LOCATION	3/F-42/F(4/F,13/F,14/F,24/F,34/F OMITTED) UNIT B8
SECTION	70mm ALUM. SECTION
GLAZING	EGL-1, EGL-1A
QUANTITY	35 Nos
REMARKS	FAÇADE(TYPE T1PFS1 FOR 3/F-42/F) ,4 BAR HINGE-LIP HING (HHMS-N16)

BD. REF :

CLIENT :

SUN HUNG KAI
REAL ESTATE AGENCY LTD.
42/F SUN HUNG KAI CENTRE, WANCHAI, HONGKONG

ARCHITECT :

lwk&partners
ARCHITECTS

MAIN CONTRACTOR :

怡輝建築有限公司
Yee Fai Building Contractors Ltd.

STRUCTURAL ENGINEER :

ARUP

FAÇADE CONSULTANT :

ALPHA CONSULTING LIMITED
Steel Structure & Façade Specialist

NOTE :

1. ALL DIMENSIONS ARE IN mm.
2. ALL ELEVATIONS ARE VIEWED FROM OUTSIDE.
3. ALL DIMENSIONS TO BE VERIFIED ON SITE BEFORE FABRICATION.

LEGEND :

- (X1) --- DETAIL MARK NO.
- (X200) --- REEFER SHEET NO.

1. F.F.L. --- FINISHED FLOOR LEVEL
2. S.F.L. --- STRUCTURAL FLOOR LEVEL
3. (R) --- REVERSED DETAIL

4. GLASS LEGEND

- EGL-1 --- 8mmHS+12mm AIR GAP+10mmTP THK. I.G.U.
- EGL-2 --- 10mm THK. CLEAR TEMPERED GLASS
- EGL-4 --- 10mm THK. TEMPERED ACID ETCHED GLASS
- EGL-1A --- 8mmHS+12mm AIR GAP+8mmTP THK. I.G.U.
- EGL-1B --- 8mmHS+12mm AIR GAP+10mmTP ACID-ETCHED THK. I.G.U.

NO.	DATE	REVISION	REVISION SUBJECT TO ARCH/COMMENT	BY
G	21/09/2022	REVISION SUBJECT TO ARCH/COMMENT	HW	
F	17/08/2022	REVISION SUBJECT TO ARCH/COMMENT	HW	
E	06/07/2022	REVISION SUBJECT TO ARCH/COMMENT	HW	
D	17/12/2021	REVISION SUBJECT TO ARCH/COMMENT	HW	
C	29/11/2021	REVISION SUBJECT TO ARCH/COMMENT	HW	
B	03/11/2021	REVISION SUBJECT TO ARCH/COMMENT	HW	
A	12/10/2021	REVISION SUBJECT TO ARCH/COMMENT	HW	

JOB NO. :

J-856

PROJECT :

PROPOSED DEVELOPMENT ABOVE LIGHT RAIL TIN WING STOP TSWTL NO.23,AREA 33,TIN SHUI WAI, N.T.

TITLE :

WINDOW SCHEDULE FOR TOWER 1 ALUM. WINDOW

DATE : 02-Aug-21 SCALE : 1:40

DRAWN BY : IYVN

CHECKED BY :



美特鋁質有限公司
MIDT ALUMINUM FABRICATOR LTD.
Units 6-8, Sunray Industrial Centre, 1/F
610 Cheong Kwai Ling Road, Kwailoon
Tel:23489211-4 Fax:(852)2727666

DWG NO. : JB56-SD-PW-5111 REV : G

REQUIRED		PROVIDED	
LOCATION	OPENABLE AREA	GLAZING AREA	GLAZING AREA
A5-MBR	0.435	0.696	0.548
A6-MBR	0.295	0.472	1.431
A7-MBR	0.435	0.696	
B6-MBR	0.435	0.696	

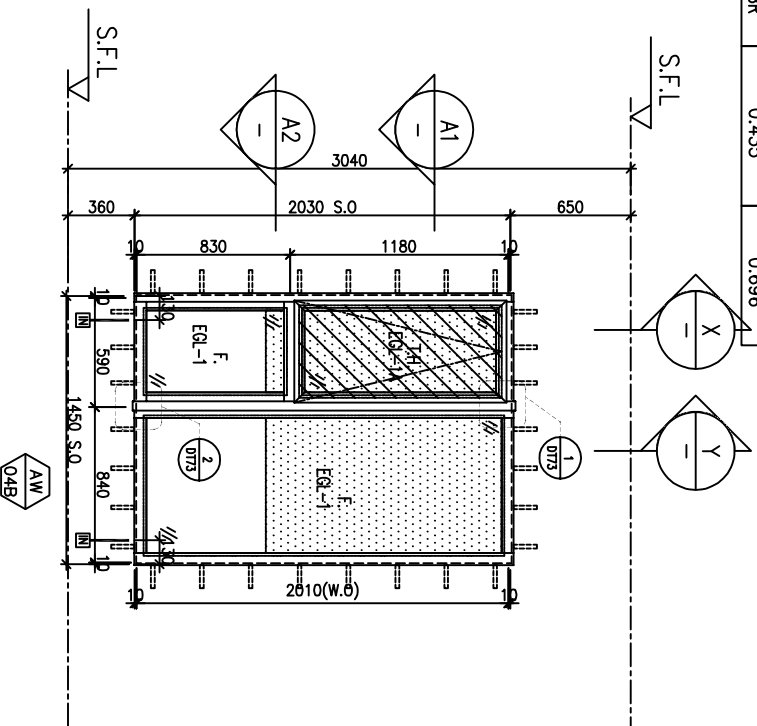

ELEVATION

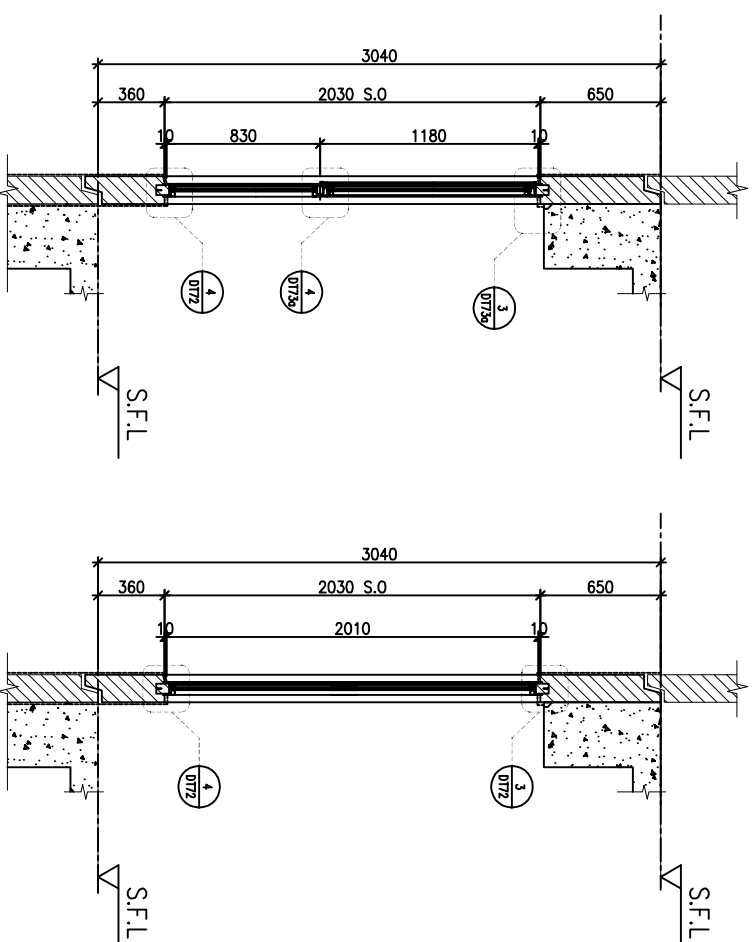
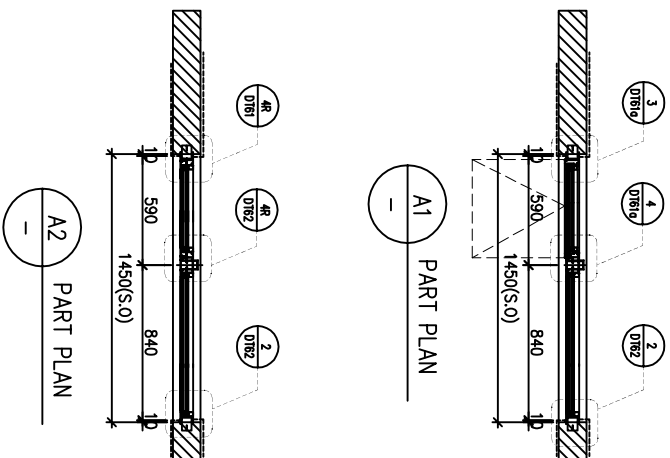

WINDOW MARK	LOCATION	SECTION	QUANTITY	REMARKS
AW 045	3/F-42/F(4/F,13/F,14/F,24/F,34/F OMITTED) UNIT A5, A6, A7, B6	70mm ALUM. SECTION	35 Nos / 35 Nos / 35 Nos / 35 Nos	4 BAR HINGE-LIP HING (HHMT-14)

BD. REF :

CLIENT :

SUN HUNG KAI
REAL ESTATE AGENCY LTD.
42/F SUN HUNG KAI CENTRE, WANCHAI, HONGKONG

ARCHITECT :

lwk&partners
ARCHITECTS

MAIN CONTRACTOR :

怡輝建築有限公司
Yee Fai Building Contractors Ltd.

STRUCTURAL ENGINEER :

ARUP
ALPHA CONSULTING LIMITED
Steel Structure & Façade Specialist

FAÇADE CONSULTANT :

ARUP
ALPHA CONSULTING LIMITED
Steel Structure & Façade Specialist

NOTE:
1. ALL DIMENSIONS ARE IN mm.
2. ALL ELEVATIONS ARE VIEWED FROM OUTSIDE.
3. ALL DIMENSIONS TO BE VERIFIED ON SITE BEFORE FABRICATION.

LEGEND :

(X1) --- DETAIL MARK NO.
(X001) --- REFER SHEET NO.

1. F.F.L. --- FINISHED FLOOR LEVEL
2. S.F.L. --- STRUCTURAL FLOOR LEVEL
3. (R) --- REVERSED DETAIL

4. GLASS LEGEND

EQ-L-1 --- 8mmHS+12mm AIR GAP+10mmTP THK. I.G.U.
EQ-L-2 --- 10mm THK. CLEAR TEMPERED GLASS
EQ-L-4 --- 10mm THK. TEMPERED ACID ETCHED GLASS
EQ-L-1A --- 8mmHS+12mm AIR GAP+8mmTP THK. I.G.U.
EQ-L-1B --- 8mmHS+12mm AIR GAP+10mmTP ACID-ETCHED THK. I.G.U.

NO.	DATE	REVISION	REVISION SUBJECT TO ARCH/COMMENT	BY
D	17/06/2022	REVISION SUBJECT TO ARCH/COMMENT		hwn
C	06/07/2022	REVISION SUBJECT TO ARCH/COMMENT		hwn
B	21/12/2021	REVISION SUBJECT TO ARCH/COMMENT		hwn
A	12/10/2021	REVISION SUBJECT TO ARCH/COMMENT		hwn

JOB NO. : J-856

PROJECT : PROPOSED DEVELOPMENT ABOVE LIGHT RAIL TIN WING STOP-TSWTL NO.23,AREA 33,TIN SHUI WAI, N.T.

TITLE : WINDOW SCHEDULE FOR TOWER 1 ALUM. WINDOW

DATE : 02-Aug-21 SCALE : 1:40

DRAWN BY : IYVN CHECKED BY :

美特鋁質有限公司
MIDI ALUMINUM FABRICATOR LTD.
Units 6-8, Sunray Industrial Centre, 1/F
610 Chee Kwo Ling Road, Kwai Tsing
Tel:23489211-4 Fax:(852)2727666
DWG NO. : J856-SD-PW-5112 REV : D

REQUIRE		PROVIDED		
LOCATION	OPENABLE AREA	GLAZING AREA	OPENABLE AREA	GLAZING AREA
A5-BR1	0.263	0.420	0.439	1.19
A7-BR1	0.263	0.420		
A8-BR1	0.269	0.431		
A8-BR2	0.286	0.457		
B6-BR1	0.263	0.420		

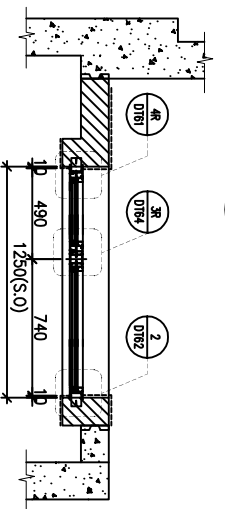
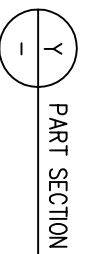
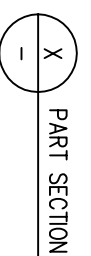
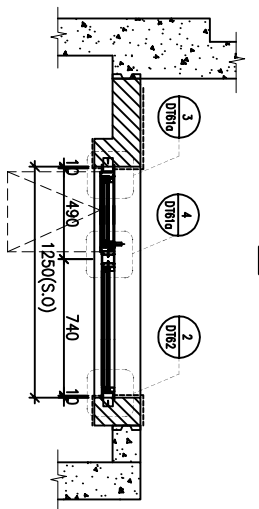
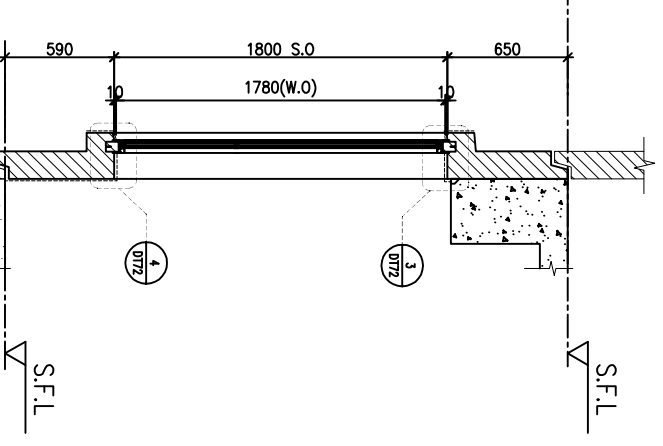
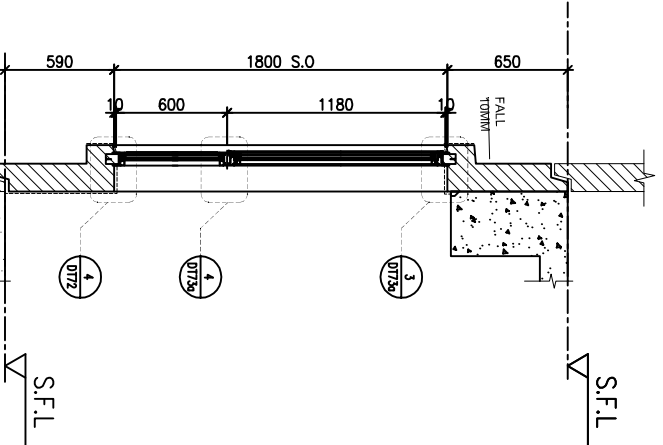
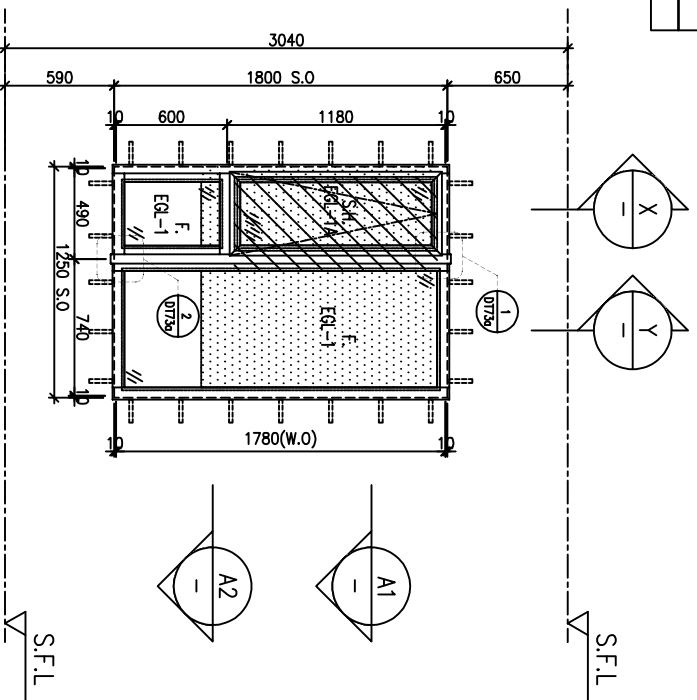

ELEVATION

WINDOW MARK	REQUIRE	PROVIDED
AW 02B	3/F-42/F(4/F,13/F,14/F,24/F,34/F OMITTED) UNIT A5, A7, B6	3/F-42/F(4/F,13/F,14/F,24/F,34/F OMITTED) UNIT A8
SECTION	70mm ALUM. SECTION	70mm ALUM. SECTION
GLAZING	EGL-1, EGL-1A	EGL-1, EGL-1A
QUANTITY	35 Nos / 35 Nos / 35 Nos / 35 Nos	35 Nos / 35 Nos
REMARKS	4 BAR HINGE-LIP HING (HHMT-14)	4 BAR HINGE-LIP HING (HHMT-14)

WINDOW MARK	REQUIRE	PROVIDED
AW 02B	3/F-42/F(4/F,13/F,14/F,24/F,34/F OMITTED) UNIT A5, A7, B6	3/F-42/F(4/F,13/F,14/F,24/F,34/F OMITTED) UNIT A8
SECTION	70mm ALUM. SECTION	70mm ALUM. SECTION
GLAZING	EGL-1, EGL-1A	EGL-1, EGL-1A
QUANTITY	35 Nos / 35 Nos / 35 Nos / 35 Nos	35 Nos / 35 Nos
REMARKS	4 BAR HINGE-LIP HING (HHMT-14)	4 BAR HINGE-LIP HING (HHMT-14)

BD. REF : _____

CLIENT : **SUN HUNG KAI**
REAL ESTATE AGENCY LTD.
42/F SUN HUNG KAI CENTRE, WANCHAI, HONGKONG

ARCHITECT : **lwk&partners**
a r c h i t e c t s

MAIN CONTRACTOR : **怡輝建築有限公司**
Yee Fai Building Contractors Ltd.

STRUCTURAL ENGINEER : **ARUP**
ALPHA CONSULTING LIMITED
Steel Structure & Façade Specialist

FAÇADE CONSULTANT : **ARUP**
ALPHA CONSULTING LIMITED
Steel Structure & Façade Specialist

NOTE :
1. ALL DIMENSIONS ARE IN mm.
2. ALL ELEVATIONS ARE VIEWED FROM OUTSIDE.
3. ALL DIMENSIONS TO BE VERIFIED ON SITE BEFORE FABRICATION.

LEGEND :
 (X1) --- DETAIL MARK NO.
 (X200) --- REEFER SHEET NO.

1. F.F.L. --- FINISHED FLOOR LEVEL
 2. S.F.L. --- STRUCTURAL FLOOR LEVEL
 3. (R) --- REVERSED DETAIL
 4. GLASS LEGEND
 EGL-1 --- 8mmHS+12mm AIR GAP+10mmTP THK. I.G.U.
 EGL-2 --- 10mm THK. CLEAR TEMPERED GLASS
 EGL-4 --- 10mm THK. TEMPERED ACID ETCHED GLASS
 EGL-1A --- 8mmHS+12mm AIR GAP+8mmTP THK. I.G.U.
 EGL-1B --- 8mmHS+12mm AIR GAP+10mmTP ACID-ETCHED THK. I.G.U.

JOB NO. : J-856
 PROJECT : PROPOSED DEVELOPMENT ABOVE LIGHT RAIL TIN WING STOP-TSWTL NO.23,AREA 33,TIN SHUI WAI, N.T.
 TITLE : WINDOW SCHEDULE FOR TOWER 1 ALUM. WINDOW

DATE : 06-Jul-22 SCALE : 1:40
 DRAWN BY : IYVN CHECKED BY : _____

REVISION SUBJECT TO ARCHICOMMENT
 NO. DATE REVISION BY

UNITA 6-8, Sunray Industrial Centre, 1/F
 610 Chee Kwo Ling Road, Kowloon
 Tel:23489211-4 Fax:(852)2727666
 DWG NO. : J856-SD-PW-5113 REV : A

LOCATION	OPENABLE AREA	GLAZING AREA	OPENABLE AREA	GLAZING AREA
A1-BR1	0.263	0.420	0.548	0.985

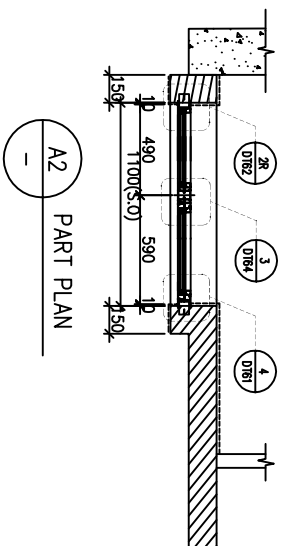
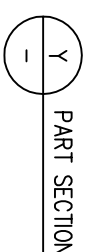
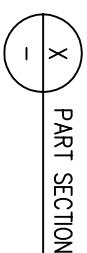
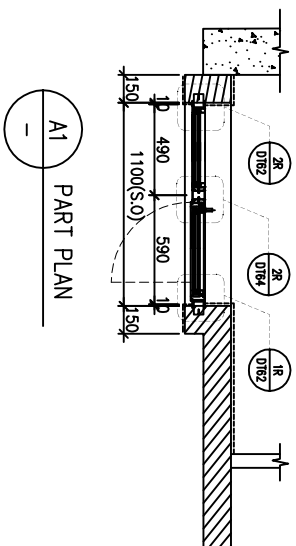
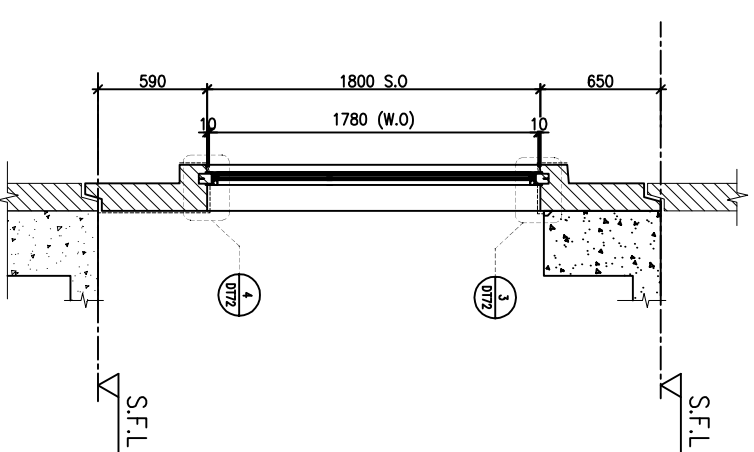
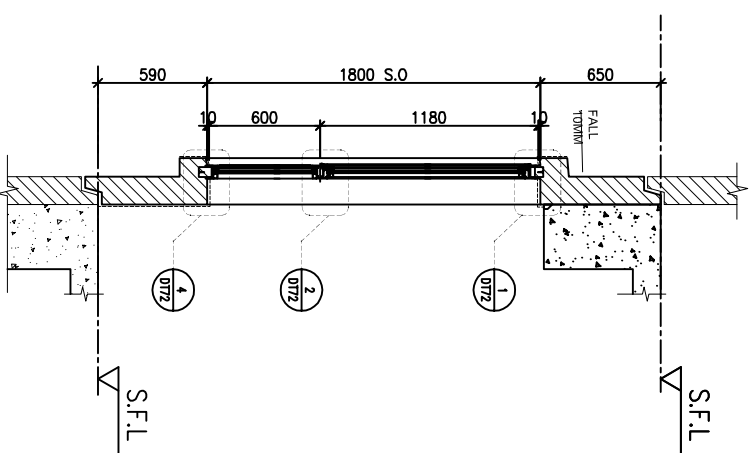
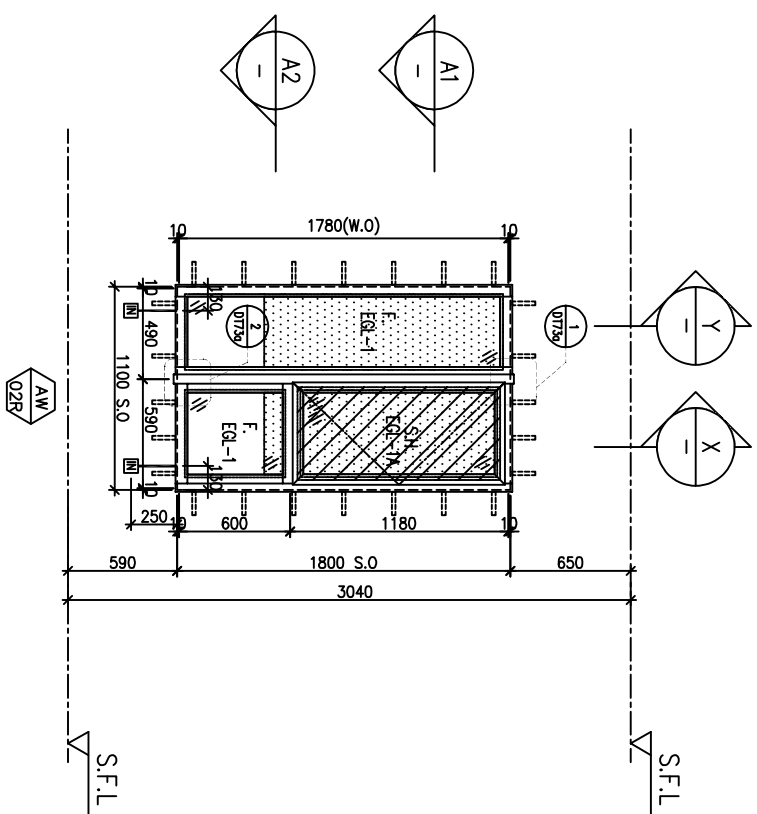

FACADE CODE		
LWK	鴻輝	UNIT
PF-01R	T2PF-10	A1

WINDOW MARK	AW 02R
LOCATION	3/F-42/F(4/F,13/F,14/F,24/F,34/F OMITTED) UNIT A1
SECTION	70mm ALUM. SECTION
GLAZING	EGL-1,EGL-1A
QUANTITY	35 Nos.
REMARKS	FACADE(TYPE T2PF01R FOR 3/F~42/F) ,4 BAR HINGE-LIP HING (HHMS-N16)

BD. REF :

CLIENT :

SUN HUNG KAI
REAL ESTATE AGENCY LTD.
42/F SUN HUNG KAI CENTRE, WANCHAI, HONGKONG

ARCHITECT :

lwk&partners
ARCHITECTS

MAIN CONTRACTOR :

怡輝建築有限公司
Yee Fai Building Contractors Ltd.

STRUCTURAL ENGINEER :

ARUP

FACADE CONSULTANT :

ALPHA CONSULTING LIMITED
Steel Structure & Façade Specialist

ELEVATION

NOTE:
1. ALL DIMENSIONS ARE IN mm.
2. ALL ELEVATIONS ARE VIEWED FROM OUTSIDE.
3. ALL DIMENSIONS TO BE VERIFIED ON SITE BEFORE FABRICATION.
LEGEND:
X1 --- DETAIL MARK NO.
X2001 --- REEFER SHEET NO.

1. F.F.L. --- FINISHED FLOOR LEVEL
2. S.F.L. --- STRUCTURAL FLOOR LEVEL
3. (R) --- REVERSED DETAIL
4. GLASS LEGEND
EGL-1 --- 8mmHS+12mm AIR GAP+10mmTP THK. I.G.U.
EGL-2 --- 10mm THK. CLEAR TEMPERED GLASS
EGL-4 --- 10mm THK. TEMPERED ACID ETCHED GLASS
EGL-1A --- 8mmHS+12mm AIR GAP+8mmTP THK. I.G.U.
EGL-1B --- 8mmHS+12mm AIR GAP+10mmTP ACID-ETCHED THK. I.G.U.

NO.	DATE	REVISION	SUBJECT TO ARCH/COMMENT	BY
H	21/09/2022	REVISION	SUBJECT TO ARCH/COMMENT	ivan
G	17/08/2022	REVISION	SUBJECT TO ARCH/COMMENT	ivan
F	18/05/2022	REVISION	SUBJECT TO ARCH/COMMENT	ivan
E	09/04/2022	REVISION	SUBJECT TO ARCH/COMMENT	ivan
D	17/12/2021	REVISION	SUBJECT TO ARCH/COMMENT	ivan
C	29/11/2021	REVISION	SUBJECT TO ARCH/COMMENT	ivan

JOB NO. : J-856

PROJECT : PROPOSED DEVELOPMENT ABOVE LIGHT RAIL TIN WING STOP TSWTL NO.23,AREA 33,TIN SHUI WAI, N.T.

TITLE : WINDOW SCHEDULE FOR TOWER 2 ALUM. WINDOW

DATE : 02-Aug-21 SCALE : 1:40

DRAWN BY : ivan CHECKED BY :

美特鋁質有限公司
MIDI ALUMINIUM FABRICATOR LTD.
Units 6-8, Sunray Industrial Centre, 1/F
610 Chee Kwo Ling Road, Kwai Tsoung
Tel:23489211-4 Fax:(852)2727666
DWG NO. : JB56-SD-PW-5201 REV : H

REQUIRED		PROVIDED		
LOCATION	OPENABLE AREA	GLAZING AREA	OPENABLE AREA	GLAZING AREA
A2-BR1	0.263	0.420	0.548	0.985
A5-BR1	0.263	0.420		

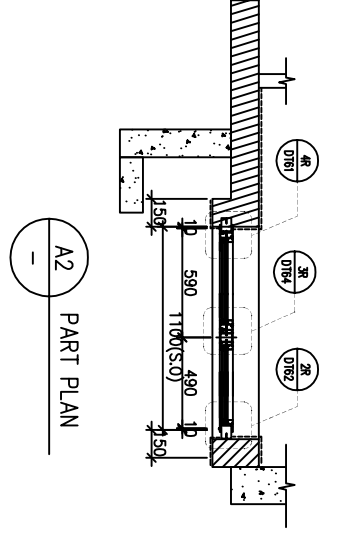
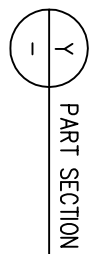
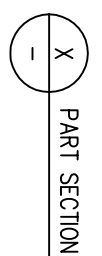
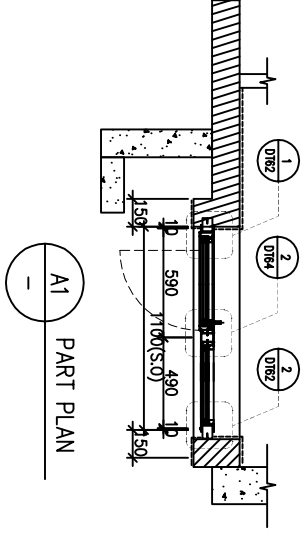
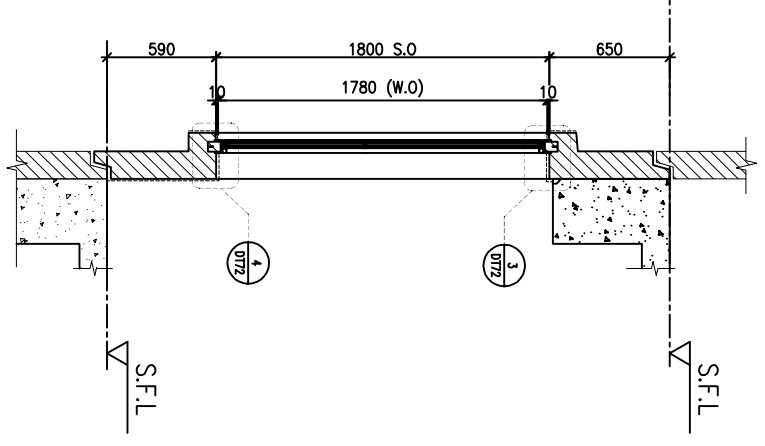
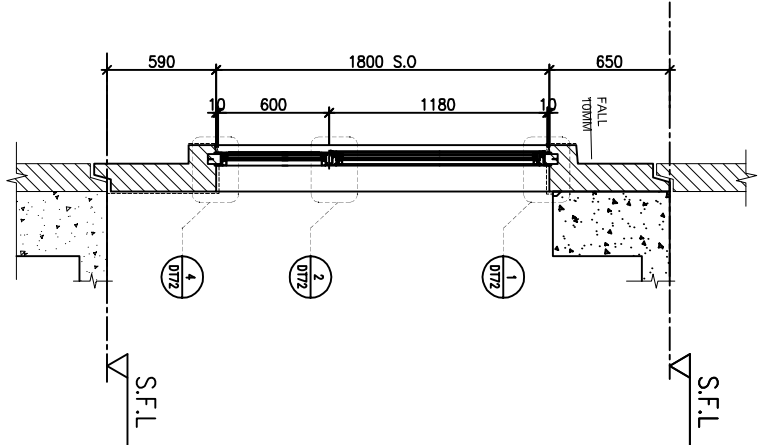
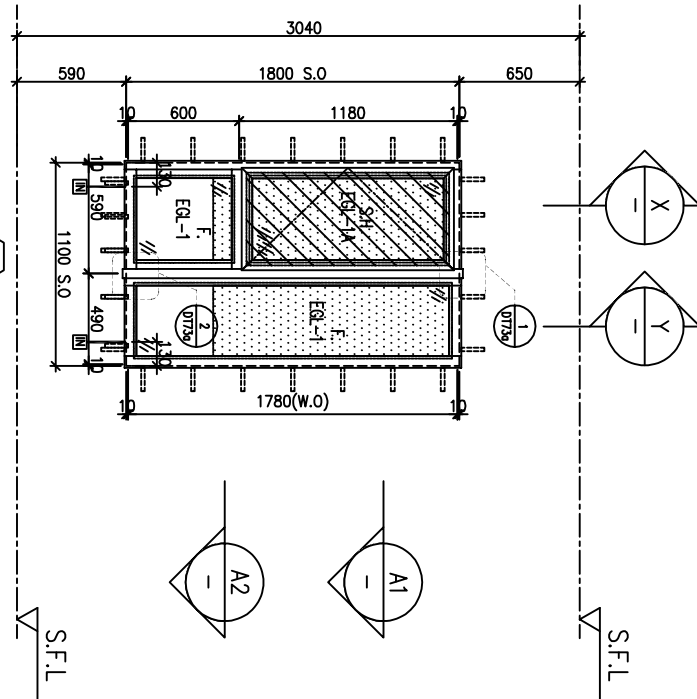

FACADE CODE		
LWK	鴻輝	UNIT
PF-02	T2PF-09	A2
PF-02R	T2PF-18	A5

WINDOW MARK	SECTION	LOCATION	REMARKS
AW 02R	70mm ALUM. SECTION	3/F-42/F(4/F,13/F,14/F,24/F,34/F OMITTED) UNIT A2	FACADE(TYPE T2PF02 FOR 3/F-42/F), 4 BAR HINGE-LIP HING (HHMS-N16)
AW 02R	70mm ALUM. SECTION	3/F-42/F(4/F,13/F,14/F,24/F,34/F OMITTED) UNIT A5	FACADE(TYPE T2PF02R FOR 3/F-42/F), 4 BAR HINGE-LIP HING (HHMS-N16)
AW 02	70mm ALUM. SECTION	3/F-42/F(4/F,13/F,14/F,24/F,34/F OMITTED) UNIT A2	FACADE(TYPE T2PF02 FOR 3/F-42/F), 4 BAR HINGE-LIP HING (HHMS-N16)
AW 02	70mm ALUM. SECTION	3/F-42/F(4/F,13/F,14/F,24/F,34/F OMITTED) UNIT A5	FACADE(TYPE T2PF02R FOR 3/F-42/F), 4 BAR HINGE-LIP HING (HHMS-N16)

BD. REF :

CLIENT :
SUN HUNG KAI
 REAL ESTATE AGENCY LTD.
 42/F SUN HUNG KAI CENTRE, WANCHAI, HONGKONG

ARCHITECT :
lwk&partners
 A R C H I T E C T S

MAIN CONTRACTOR :
怡輝建築有限公司
Yee Fai Building Contractors Ltd.

STRUCTURAL ENGINEER :
ARUP
 ALPHA CONSULTING LIMITED
 Steel Structure & Façade Specialist

FACADE CONSULTANT:

NOTE:
 1. ALL DIMENSIONS ARE IN mm.
 2. ALL ELEVATIONS ARE VIEWED FROM OUTSIDE.
 3. ALL DIMENSIONS TO BE VERIFIED ON SITE BEFORE FABRICATION.
 LEGEND:
 (X1) --- DETAIL MARK NO.
 (X001) --- REEFER SHEET NO.

1. F.F.L. --- FINISHED FLOOR LEVEL
 2. S.F.L. --- STRUCTURAL FLOOR LEVEL
 3. (R) --- REVERSED DETAIL
 4. GLASS LEGEND
 EG1-1 --- 8mmHS+12mm AIR GAP+10mmTP THK. I.G.U.
 EG1-2 --- 10mm THK. CLEAR TEMPERED GLASS
 EG1-4 --- 10mm THK. TEMPERED ACID ETCHED GLASS
 EG1-1A --- 8mmHS+12mm AIR GAP+8mmTP THK. I.G.U.
 EG1-1B --- 8mmHS+12mm AIR GAP+10mmTP THK. I.G.U.
 EG1-1B --- 8mmHS+12mm AIR GAP+10mmTP THK. I.G.U.

NO.	DATE	REVISION	REVISION SUBJECT TO ARCH/COMMENT
G	21/09/2022	REVISION SUBJECT TO ARCH/COMMENT	REV
F	17/08/2022	REVISION SUBJECT TO ARCH/COMMENT	REV
E	18/06/2022	REVISION SUBJECT TO ARCH/COMMENT	REV
D	08/04/2022	REVISION SUBJECT TO ARCH/COMMENT	REV
C	17/02/2021	REVISION SUBJECT TO ARCH/COMMENT	REV
B	29/11/2021	REVISION SUBJECT TO ARCH/COMMENT	REV
A	03/11/2021	REVISION SUBJECT TO ARCH/COMMENT	REV

JOB NO. : J-856
 PROJECT : PROPOSED DEVELOPMENT ABOVE LIGHT RAIL TIN WING STOP-TSWTL NO.23,AREA 33,TIN SHUI WAI, N.T.
 TITLE : WINDOW SCHEDULE FOR TOWER 2 ALUM. WINDOW

DATE : 02-Aug-21 SCALE : 1:40
 DRAWN BY : IYVN CHECKED BY :
美特鋁質有限公司
 MIDT ALUMINUM FABRICATOR LTD.
 Units 6-8, Sunray Industrial Centre, 1/F
 610 Chee Kwo Ling Road, Kwai Tsou
 Tel:23489211-4 Fax:(852)2727666
 DWG NO. : J856-SD-PW-5202 REV : G

LOCATION	OPENABLE AREA	GLAZING AREA	OPENABLE AREA	GLAZING AREA
A2-BR2	0.263	0.420	0.548	0.985

LOCATION	OPENABLE AREA	GLAZING AREA	OPENABLE AREA	GLAZING AREA
A2-MBR	0.477	0.763	0.548	1.495

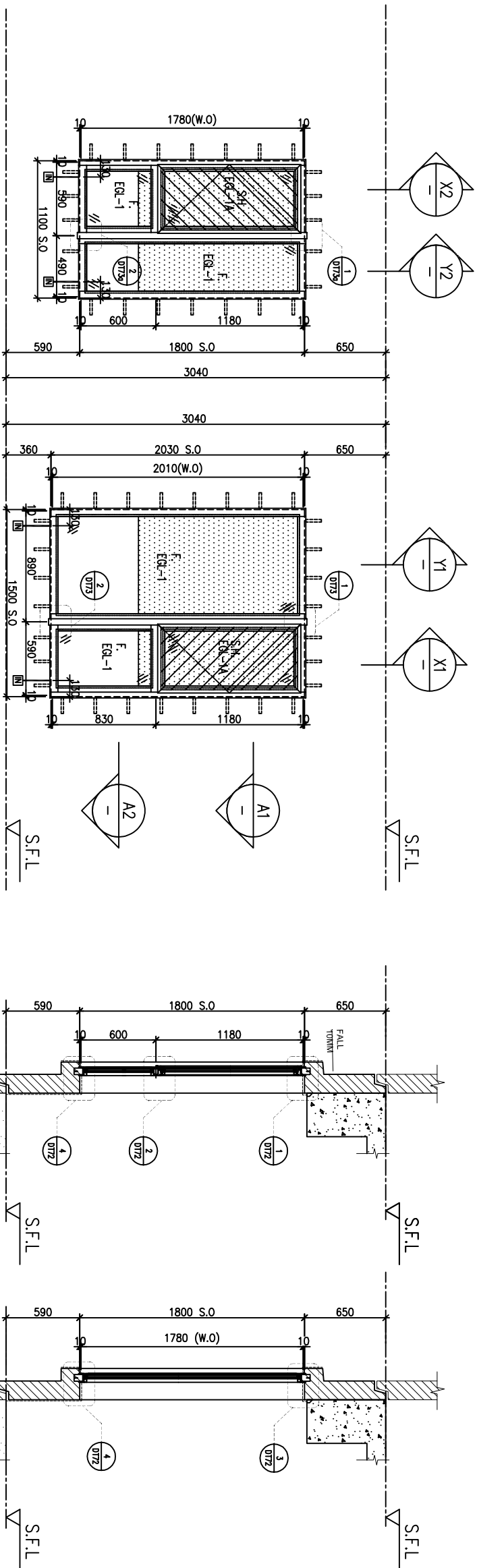

ELEVATION

WINDOW MARK	FAÇADE CODE	UNIT
AW 02	鴻輝	A2
AW 03R	T2PF-08	A2

A2 PART PLAN

X PART SECTION

Y1 PART SECTION

LOCATION	3/F-42/F(4/F,13/F,14/F,24/F,34/F OMITTED) UNIT A2
SECTION	70mm ALUM. SECTION
GLAZING	EGL-1, EGL-1A
QUANTITY	35 Nos.
REMARKS	FAÇADE(TYPE T2PF03R FOR 3/F~42/F) , 4 BAR HINGE-LIP HING (HHMS-N16)

BD. REF :

CLIENT :

SUN HUNG KAI
REAL ESTATE AGENCY LTD.
42/F SUN HUNG KAI CENTRE, WANCHAI, HONGKONG

ARCHITECT :

lwk&partners
A R C H I T E C T S

MAIN CONTRACTOR :

怡輝建築有限公司
Yee Fai
Building Contractors Ltd.

STRUCTURAL ENGINEER :

ARUP

FAÇADE CONSULTANT :

ALPHA CONSULTING LIMITED
Steel Structure & Façade Specialist

- NOTE :
1. ALL DIMENSIONS ARE IN mm.
 2. ALL ELEVATIONS ARE VIEWED FROM OUTSIDE.
 3. ALL DIMENSIONS TO BE VERIFIED ON SITE BEFORE FABRICATION.

LEGEND :

X1 --- DETAIL MARK NO.
X2001 --- REEFER SHEET NO.

1. F.F.L. --- FINISHED FLOOR LEVEL
2. S.F.L. --- STRUCTURAL FLOOR LEVEL
3. (R) --- REVERSED DETAIL

4. GLASS LEGEND

- EGL-1 --- 6mmHS+12mm AIR GAP+10mmTP THK. I.G.U.
EGL-2 --- 10mm THK. CLEAR TEMPERED GLASS
EGL-4 --- 10mm THK. TEMPERED ACID ETCHED GLASS
EGL-1A --- 6mmHS+12mm AIR GAP+8mmTP THK. I.G.U.
EGL-1B --- 8mmHS+12mm AIR GAP+10mmTP ACID-ETCHED THK. I.G.U.

NO.	DATE	REVISION	REVISION SUBJECT TO ARCH/COMMENT	BY
G	21/09/2022	REVISION SUBJECT TO ARCH/COMMENT		HW
F	17/08/2022	REVISION SUBJECT TO ARCH/COMMENT		HW
E	17/06/2022	REVISION SUBJECT TO ARCH/COMMENT		HW
D	09/04/2022	REVISION SUBJECT TO ARCH/COMMENT		HW
C	17/12/2021	REVISION SUBJECT TO ARCH/COMMENT		HW
B	29/11/2021	REVISION SUBJECT TO ARCH/COMMENT		HW
A	03/11/2021	REVISION SUBJECT TO ARCH/COMMENT		HW

JOB NO. : J-856

PROJECT : PROPOSED DEVELOPMENT ABOVE LIGHT RAIL TIN WING STOP,T5WTL NO.23,AREA 33,TIN SHUI WAI, N.T.

TITLE : WINDOW SCHEDULE FOR TOWER 2 ALUM. WINDOW

DATE : 02-Aug-21 SCALE : 1:40

DRAWN BY : IYVN CHECKED BY :

美特鋁質有限公司
MIDI ALUMINIUM FABRICATOR LTD.
Units 6-8, Sunray Industrial Centre, 1/F
610 Chee Kwo Ling Road, Kwai Tsou
Tel:23489211-4 Fax:(852)27727666
DWG NO. : J856-SD-PW-5203 REV : G

REQUIRED		PROVIDED		
LOCATION	OPENABLE AREA	GLAZING AREA	OPENABLE AREA	GLAZING AREA
A3-MBR	0.435	0.696	0.548	1.24
A7-MBR	0.435	0.696		
B7-MBR	0.435	0.696		

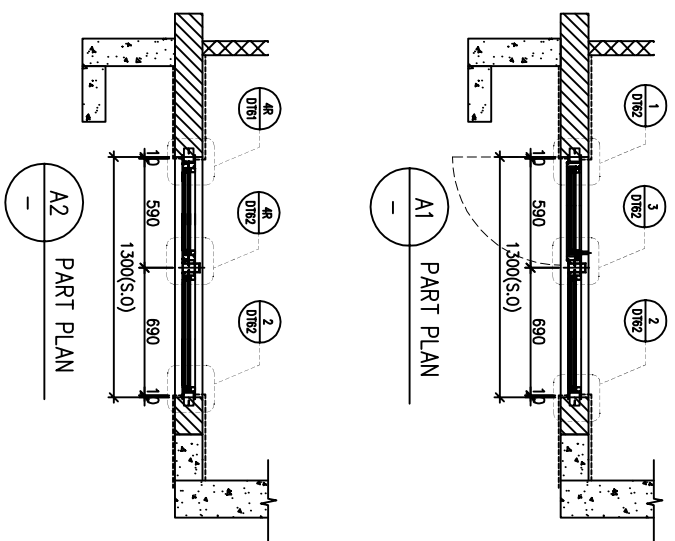
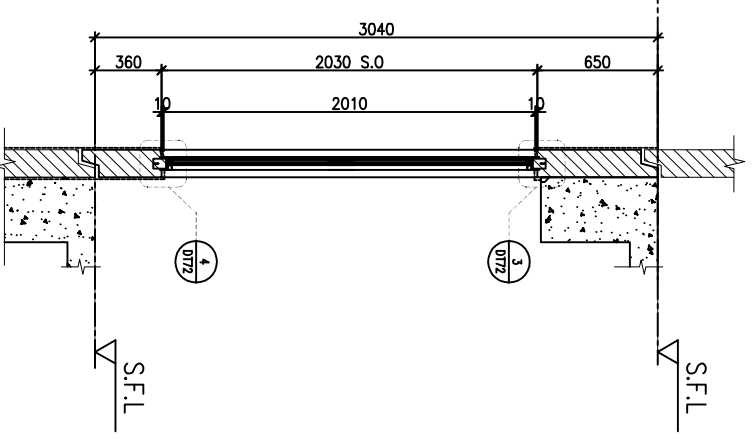
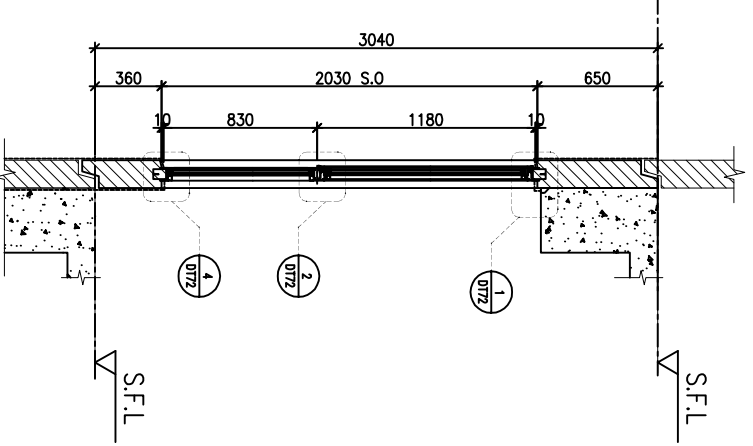
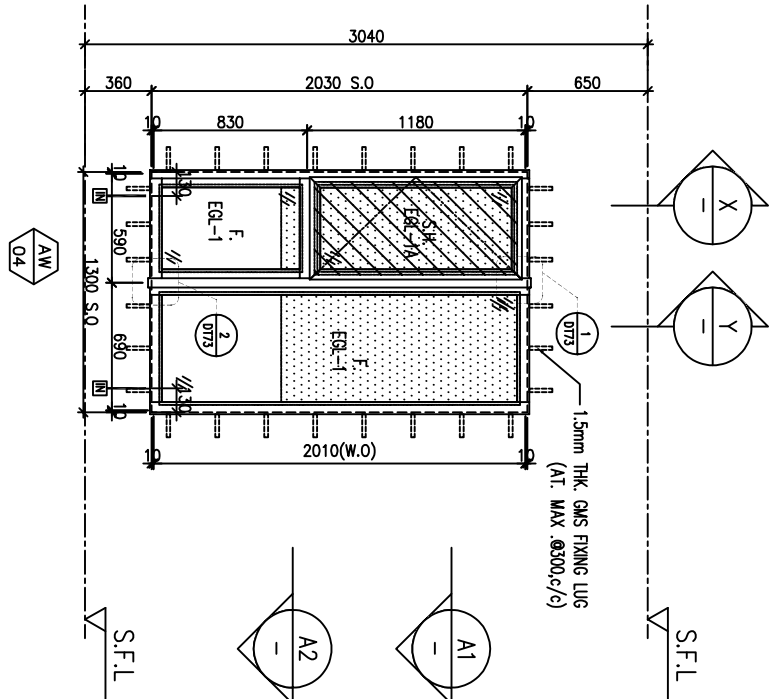

FACADE CODE		
LWK	鴻輝	UNIT
PF-04	T2PF-24	B7
PF-04R	T2PF-07	A3
PF-04R	T2PF-15	A7

WINDOW MARK	AW 04
LOCATION	3/F-42/F(4/F,13/F,14/F,24/F,34/F OMITTED) UNIT A3, A7, B7
SECTION	70mm ALUM. SECTION
GLAZING	EGL-1, EGL-1A
QUANTITY	35 Nos / 35 Nos / 35 Nos
REMARKS	FACADE(TYPE T2PF04/04R FOR 3/F~42/F), 4 BAR HINGE-LIP HING (HHMS-N16)

BD. REF :

CLIENT :
SUN HUNG KAI
 REAL ESTATE AGENCY LTD.
 42/F SUN HUNG KAI CENTRE, WANCHAI, HONGKONG

ARCHITECT :
lwk&partners
 a r c h i t e c t s

MAIN CONTRACTOR :
 怡輝建築有限公司
Yee Fai
 Building Contractors Ltd.

STRUCTURAL ENGINEER :
ARUP
 ALPHA CONSULTING LIMITED
 Steel Structure & Facade Specialist

NOTE :
 1. ALL DIMENSIONS ARE IN mm.
 2. ALL ELEVATIONS ARE VIEWED FROM OUTSIDE.
 3. ALL DIMENSIONS TO BE VERIFIED ON SITE BEFORE FABRICATION.
 LEGEND :
 (X1) --- DETAIL MARK NO.
 (X000) --- REEFER SHEET NO.

1. F.F.L. --- FINISHED FLOOR LEVEL
 2. S.F.L. --- STRUCTURAL FLOOR LEVEL
 3. (R) --- REVERSED DETAIL
 4. GLASS LEGEND
 EGL-1 --- 8mmHS+12mm AIR GAP+10mmTP THK. I.G.U.
 EGL-2 --- 10mm THK. CLEAR TEMPERED GLASS
 EGL-4 --- 10mm THK. TEMPERED ACID ETCHED GLASS
 EGL-1A --- 8mmHS+12mm AIR GAP+8mmTP THK. I.G.U.
 EGL-1B --- 8mmHS+12mm AIR GAP+10mmTP THK. I.G.U.

NO.	DATE	REVISION	REVISION SUBJECT TO ARCH/COMMENT	BY
H	21/09/2022	REVISION SUBJECT TO ARCH/COMMENT		hwn
G	17/08/2022	REVISION SUBJECT TO ARCH/COMMENT		hwn
F	17/05/2022	REVISION SUBJECT TO ARCH/COMMENT		hwn
E	09/04/2022	REVISION SUBJECT TO ARCH/COMMENT		hwn
D	17/12/2021	REVISION SUBJECT TO ARCH/COMMENT		hwn
C	29/11/2021	REVISION SUBJECT TO ARCH/COMMENT		hwn

JOB NO. : J-856
 PROJECT : PROPOSED DEVELOPMENT ABOVE LIGHT RAIL TIN WING STOP-TSWTL NO.23,AREA 33,TIN SHUI WAI, N.T.
 TITLE : WINDOW SCHEDULE FOR TOWER 2 ALUM. WINDOW

DATE : 02-Aug-21 SCALE : 1:40
 DRAWN BY : ivon CHECKED BY :
美特鋁質有限公司
 MIDT ALUMINUM FABRICATOR LTD.
 Units 6-8, Sunray Industrial Centre, 1/F
 610 Chee Kwo Ling Road, Kwai Tsan
 Tel:23489211-4 Fax:(852)2727666
 DWG NO. : JB56-SD-PW-5204 REV : H

REQUIRE		PROVIDED	
LOCATION	OPENABLE AREA	GLAZING AREA	GLAZING AREA
A3-BR1	0.263	0.420	0.548
A7-BR1	0.263	0.420	0.985
B2-BR1	0.263	0.420	
B6-BR1	0.263	0.420	
B7-BR1	0.263	0.420	

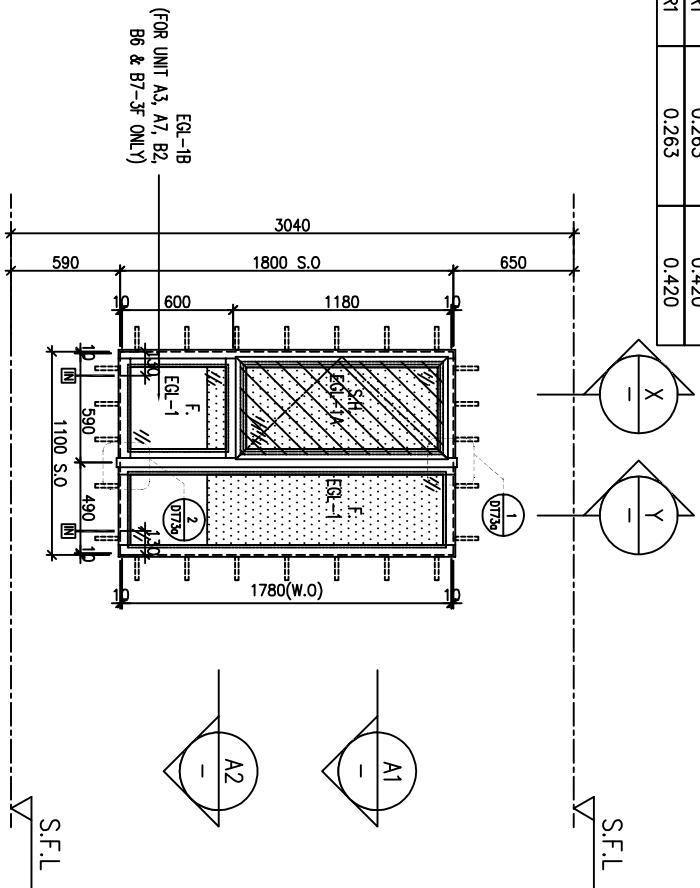

ELEVATION

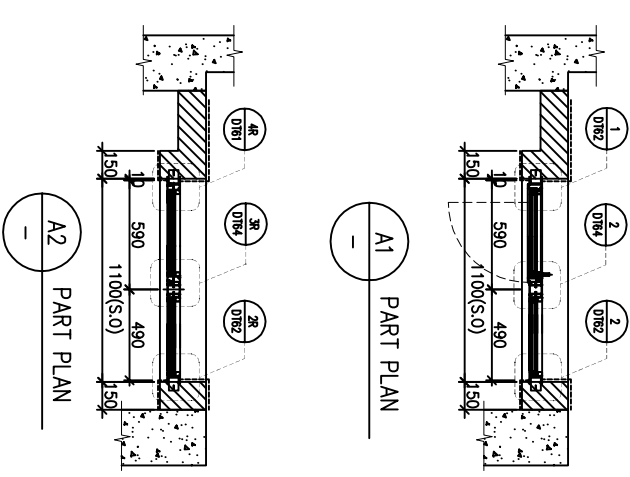
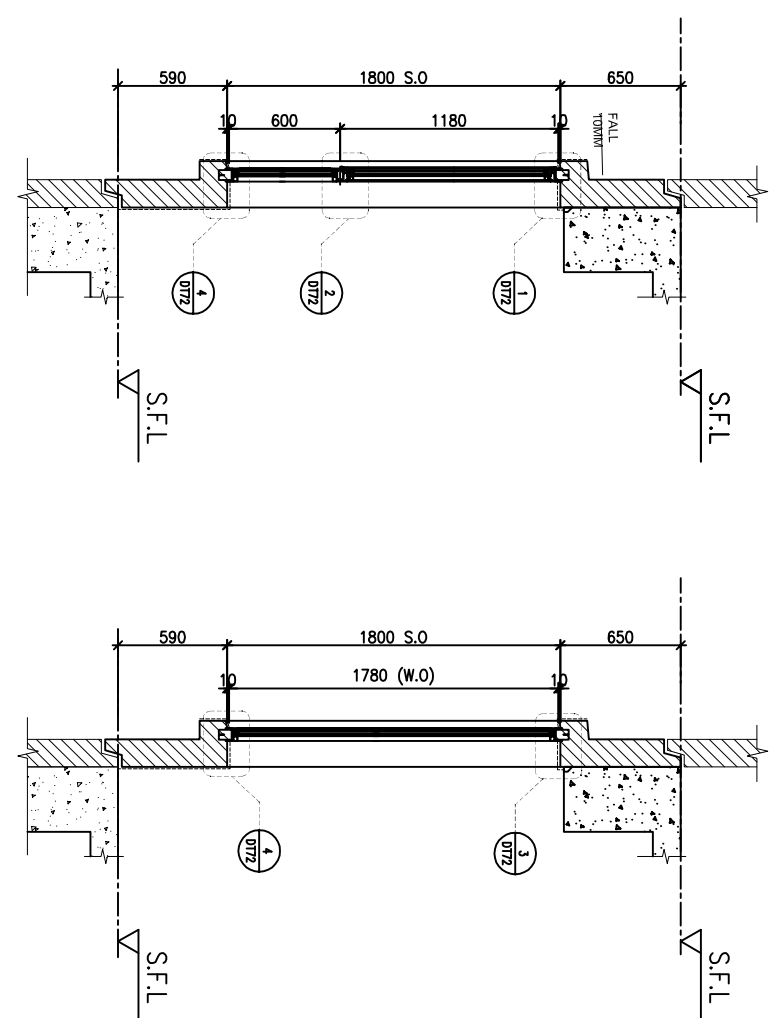

FACADE CODE		FACADE CODE	
LWK	UNIT	LWK	UNIT
PF-05	T2PF-06	A3	
PF-05	T2PF-14	A7	
PF-05	T2PF-22	B6	
PF-05	T2PF-25	B7	

WINDOW MARK

WINDOW MARK

LOCATION	3/F-42/F(4/F,13/F,14/F,24/F,34/F OMITTED) UNIT A3, A7(5-42/F), B6(5-42/F), B7(5-42/F)
SECTION	70mm ALUM. SECTION
GLAZING	EGL-1,EGL-1A
QUANTITY	35 Nos / 34 Nos / 34 Nos / 34 Nos
REMARKS	FACADE(TYPE T2PF05 FOR 3/F~42/F), 4 BAR HINGE-LIP HING (HHMS-N16)

BD. REF :

CLIENT :

SUN HUNG KAI
REAL ESTATE AGENCY LTD.
42/F SUN HUNG KAI CENTRE, WANCHAI, HONGKONG

ARCHITECT :

lwk&partners
ARCHITECTS

MAIN CONTRACTOR :

Yee Fai
Building Contractors Ltd.

STRUCTURAL ENGINEER :

ARUP
ALPHA CONSULTING LIMITED
Steel Structure & Façade Specialist

FACADE CONSULTANT :

ARUP
ALPHA CONSULTING LIMITED
Steel Structure & Façade Specialist

NOTE :

1. ALL DIMENSIONS ARE IN mm.
2. ALL ELEVATIONS ARE VIEWED FROM OUTSIDE.
3. ALL DIMENSIONS TO BE VERIFIED ON SITE BEFORE FABRICATION.
LEGEND :

X1 --- DETAIL MARK NO.
X2001 --- REEFER SHEET NO.
1. F.F.L. --- FINISHED FLOOR LEVEL
2. S.F.L. --- STRUCTURAL FLOOR LEVEL
3. (R) --- REVERSED DETAIL
4. GLASS LEGEND

EQ1-1 --- 8mmHS+12mm AIR GAP+10mmTP THK. I.G.U.
EQ1-2 --- 10mm THK. CLEAR TEMPERED GLASS
EQ1-4 --- 10mm THK. TEMPERED ACID ETCHED GLASS
EQ1-1A --- 8mmHS+12mm AIR GAP+8mmTP THK. I.G.U.
EQ1-1B --- 8mmHS+12mm AIR GAP+10mmTP ADID-ETCHED THK. I.G.U.

JOB NO. : J-856
PROJECT : PROPOSED DEVELOPMENT ABOVE LIGHT RAIL TIN WING STOP-TSWTL NO.23,AREA 33,TIN SHUI WAI, N.T.
TITLE : WINDOW SCHEDULE FOR TOWER 2 ALUM. WINDOW

DATE : 02-Aug-21
SCALE : 1:40
DRAWN BY : IYVN
CHECKED BY :

美特铝质有限公司
MIDI ALUMINIUM FABRICATOR LTD.
Units 6-8, Sunray Industrial Centre, 1/F
610 Chee Kwo Ling Road, Kowloon
Tel:23489211-4 Fax:6527272666
DWG NO. : 1856-SD-PW-5205 REV : H

REQUIRE		PROVIDED		
LOCATION	OPENABLE AREA	GLAZING AREA	OPENABLE AREA	GLAZING AREA
A5-MBR	0.435	0.696	0.548	1.24
A6-MBR	0.295	0.472		

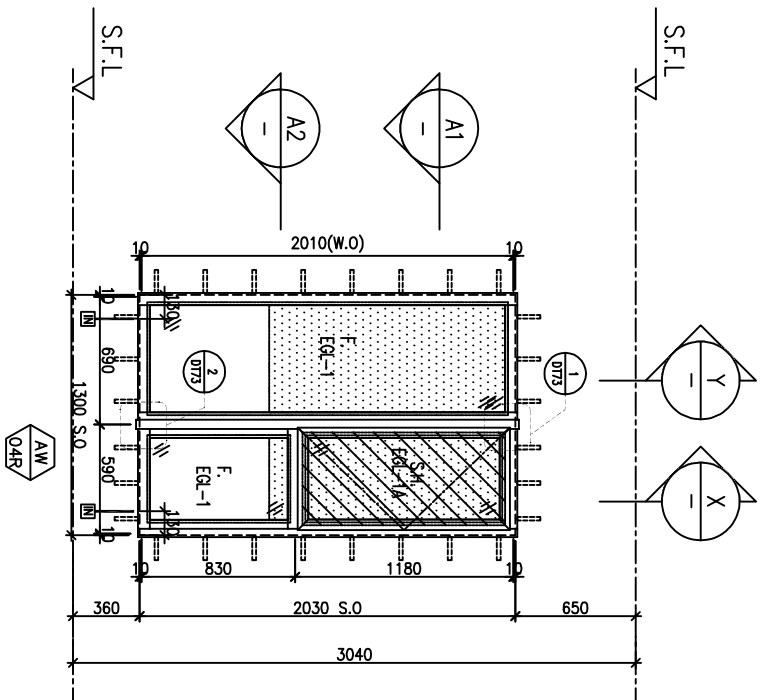

ELEVATION

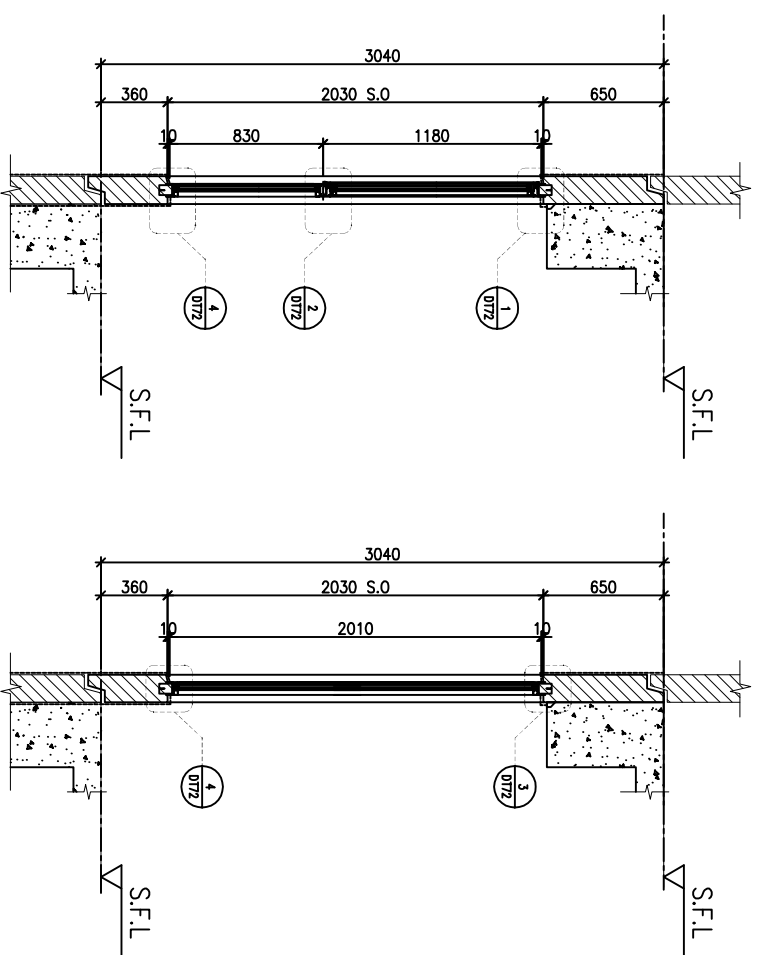
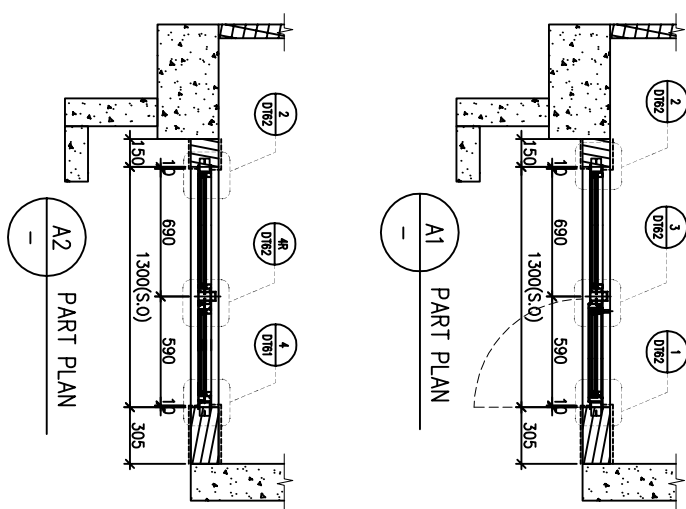

FACADE CODE		
LWK	鴻輝	UNIT
PF-06R	T2PF-17	A5

WINDOW MARK	AW OAR
LOCATION	3/F-42/F(4/F,13/F,14/F,24/F,34/F OMITTED) UNIT A5 ,A6(3/F)
SECTION	70mm ALUM. SECTION
GLAZING	EGL-1,EGL-1A
QUANTITY	35 Nos / 1 No
REMARKS	FACADE(TYPE T2PF06R FOR 3/F~42/F) ,4 BAR HINGE-LIP HING (HHMS-N16)

WINDOW MARK	AW O4
LOCATION	3/F-42/F(4/F,13/F,14/F,24/F,34/F OMITTED) UNIT A6(5/F-42/F)
SECTION	70mm ALUM. SECTION
GLAZING	EGL-1,EGL-1A
QUANTITY	34 Nos
REMARKS	FACADE(TYPE T2PF06 FOR 3/F~42/F) ,4 BAR HINGE-LIP HING (HHMS-N16)

BD. REF :

CLIENT :

SUN HUNG KAI
REAL ESTATE AGENCY LTD.
42/F SUN HUNG KAI CENTRE, WANCHAI, HONGKONG

ARCHITECT :
lwk&partners
ARCHITECTS

MAIN CONTRACTOR :
怡輝建築有限公司
Yeek Fai Building Contractors Ltd.

STRUCTURAL ENGINEER :

ARUP

FACADE CONSULTANT:
ALPHA CONSULTING LIMITED
Steel Structure & Façade Specialist

NOTE:
1. ALL DIMENSIONS ARE IN mm.
2. ALL ELEVATIONS ARE VIEWED FROM OUTSIDE.
3. ALL DIMENSIONS TO BE VERIFIED ON SITE BEFORE FABRICATION.

LEGEND:
X1 --- DETAIL MARK NO.
X2001 --- REEFER SHEET NO.

1. F.F.L. --- FINISHED FLOOR LEVEL
2. S.F.L. --- STRUCTURAL FLOOR LEVEL
3. (R) --- REVERSED DETAIL

4. GLASS LEGEND
EGL-1 --- 8mmHS+12mm AIR GAP+10mmTP THK. I.G.U.
EGL-2 --- 10mm THK. CLEAR TEMPERED GLASS
EGL-4 --- 10mm THK. TEMPERED ACID ETCHED GLASS
EGL-1A --- 8mmHS+12mm AIR GAP+8mmTP THK. I.G.U.
EGL-1B --- 8mmHS+12mm AIR GAP+10mmTP ACID-ETCHED THK. I.G.U.

NO.	DATE	REVISION	SUBJECT TO ARCH/COMMENT	BY
1	21/09/2022	REVISION SUBJECT TO ARCH/COMMENT		HW
H	17/08/2022	REVISION SUBJECT TO ARCH/COMMENT		HW
G	27/06/2022	REVISION SUBJECT TO ARCH/COMMENT		HW
F	17/05/2022	REVISION SUBJECT TO ARCH/COMMENT		HW
E	09/04/2022	REVISION SUBJECT TO ARCH/COMMENT		HW
D	17/12/2021	REVISION SUBJECT TO ARCH/COMMENT		HW
C	29/11/2021	REVISION SUBJECT TO ARCH/COMMENT		HW

JOB NO. : J-856

PROJECT :
PROPOSED DEVELOPMENT ABOVE
LIGHT RAIL TIN WING STOP,T5WTL
NO.23,AREA 33,TIN SHUI WAI, N.T.

TITLE :
WINDOW SCHEDULE FOR
TOWER 2 ALUM. WINDOW

DATE : 02-Aug-21 SCALE : 1:40

DRAWN BY : IYVN CHECKED BY :

美特鋁質有限公司
MIDI ALUMINIUM FABRICATOR LTD.
Units 6-8, Sunray Industrial Centre, 1/F
610 Cheong Kwo Ling Road, Kwai Tsing
Tel:23489211-4 Fax:6527272666
DWG NO. : 1856-SD-PW-5206 REV. : 1

REQUIRE		PROVIDED	
LOCATION	OPENABLE AREA	GLAZING AREA	GLAZING AREA
A8-BR1	0.263	0.420	0.548
B1-BR1	0.263	0.420	0.985
B8-BR1	0.263	0.420	

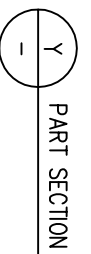
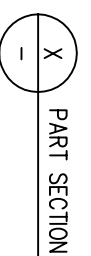
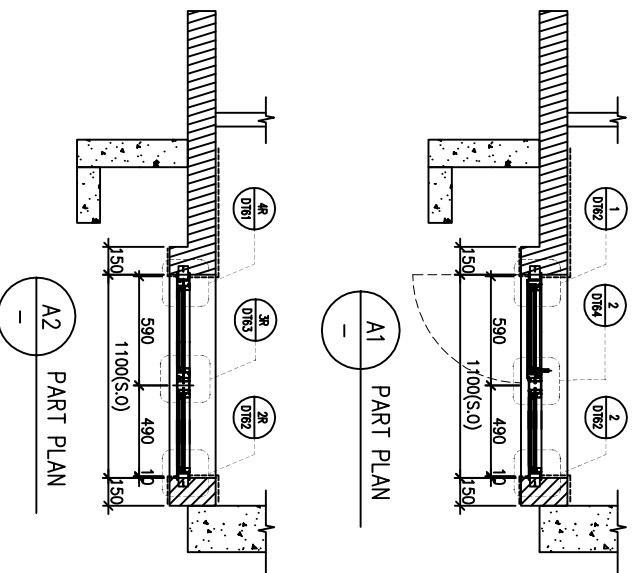
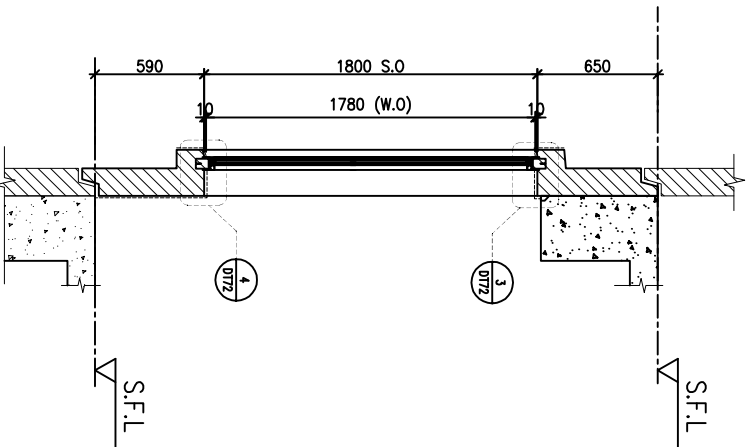
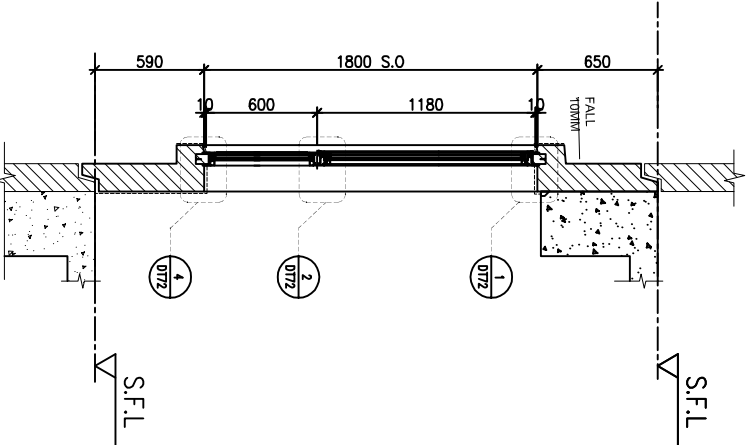
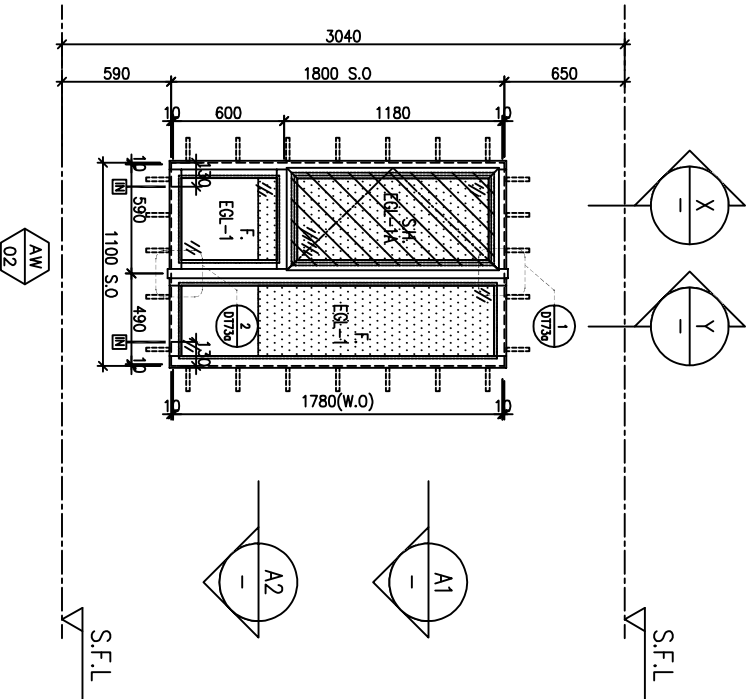

ELEVATION

FACADE CODE		
LWK	鴻輝	UNIT
PF-08	T2PF-01	B1
PF-08	T2PF-13	A8
PF-08R	T2PF-26	B8

WINDOW MARK	SECTION	LOCATION	REMARKS
AW 02	70mm ALUM. SECTION	3/F-42/F(4/F,13/F,14/F,24/F,34/F OMITTED) UNIT B1, A8	FACADE(TYPE T2PF08 FOR 3/F-42/F), 4 BAR HINGE-LIP HING (HHMS-N16)
AW 02R	70mm ALUM. SECTION	3/F-42/F(4/F,13/F,14/F,24/F,34/F OMITTED) UNIT B8	FACADE(TYPE T2PF08R FOR 3/F-42/F), 4 BAR HINGE-LIP HING (HHMS-N16)
AW 02	70mm ALUM. SECTION	3/F-42/F(4/F,13/F,14/F,24/F,34/F OMITTED) UNIT B1, A8	FACADE(TYPE T2PF08 FOR 3/F-42/F), 4 BAR HINGE-LIP HING (HHMS-N16)
AW 02R	70mm ALUM. SECTION	3/F-42/F(4/F,13/F,14/F,24/F,34/F OMITTED) UNIT B8	FACADE(TYPE T2PF08R FOR 3/F-42/F), 4 BAR HINGE-LIP HING (HHMS-N16)

BD. REF :

CLIENT :

SUN HUNG KAI
REAL ESTATE AGENCY LTD.
42/F SUN HUNG KAI CENTRE, WANCHAI, HONGKONG

ARCHITECT :

lwk&partners
ARCHITECTS

MAIN CONTRACTOR :

ARUP
ALPHA CONSULTING LIMITED
Steel Structure & Façade Specialist

STRUCTURAL ENGINEER :

Yee Fai
Building Contractors Ltd.

FACADE CONSULTANT :

ARUP
ALPHA CONSULTING LIMITED
Steel Structure & Façade Specialist

NOTE :

1. ALL DIMENSIONS ARE IN mm.
2. ALL ELEVATIONS ARE VIEWED FROM OUTSIDE.
3. ALL DIMENSIONS TO BE VERIFIED ON SITE BEFORE FABRICATION.

LEGEND :

- (X1) --- DETAIL MARK NO.
- (X200) --- REEFER SHEET NO.
- 1. F.F.L. --- FINISHED FLOOR LEVEL
- 2. S.F.L. --- STRUCTURAL FLOOR LEVEL
- 3. (R) --- REVERSED DETAIL

4. GLASS LEGEND

- EQ1-1 --- 6mmHS+12mm AIR GAP+10mmTP THK. I.G.U.
- EQ1-2 --- 10mm THK. CLEAR TEMPERED GLASS
- EQ1-4 --- 10mm THK. TEMPERED ACID ETCHED GLASS
- EQ1-1A --- 6mmHS+12mm AIR GAP+8mmTP THK. I.G.U.
- EQ1-1B --- 8mmHS+12mm AIR GAP+10mmTP ACID-ETCHED THK. I.G.U.

JOB NO. :

J-856

PROJECT :

PROPOSED DEVELOPMENT ABOVE LIGHT RAIL TIN WING STOP-TSWTL NO.23,AREA 33,TIN SHUI WAI, N.T.

TITLE :

WINDOW SCHEDULE FOR TOWER 2 ALUM. WINDOW

DATE :

02-Aug-21

SCALE :

1:40

DRAWN BY :

Ivon

CHECKED BY :

Ivon

UNIT 6-8, SUNRISE INDUSTRIAL CENTRE, 1/F, 610 CHIA LING ROAD, KOWLOON

TEL: 23489211-4, FAX: (852) 2727666

DWG NO. :

1856-SD-PW-5207

REV. :

G

LOCATION	OPENABLE AREA	GLAZING AREA	OPENABLE AREA	GLAZING AREA
B3-KIT	0.251	0.401	0.549	0.456

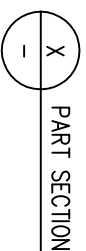
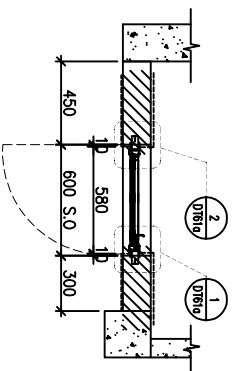
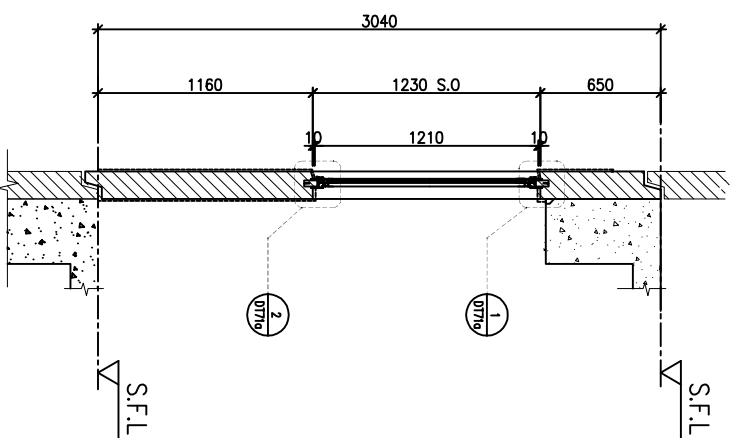
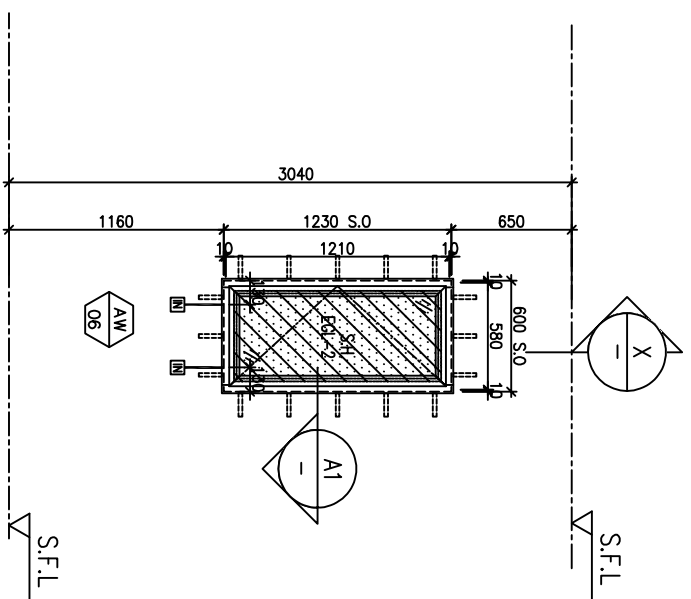

ELEVATION

FACADE CODE		
LWK	鴻輝	UNIT
PF-09	T2PF-05	B3

WINDOW MARK	AW 06
LOCATION	3/F-42/F(4/F,13/F,14/F,24/F,34/F OMITTED) UNIT B3
SECTION	50mm ALUM. SECTION
GLAZING	EGL-2
QUANTITY	35 Nos
REMARKS	FACADE(TYPE T2PF09 FOR 3/F-42/F) ,4 BAR HINGE-LIP HING (HHMS-N16)

B.D. REF :

CLIENT :

SUN HUNG KAI
REAL ESTATE AGENCY LTD.
42/F SUN HUNG KAI CENTRE, WANCHAI, HONGKONG

ARCHITECT :

lwk&partners
a r c h i t e c t s

MAIN CONTRACTOR :

怡輝建築有限公司
Yee Fai Building Contractors Ltd.

STRUCTURAL ENGINEER :

ARUP
ALPHA CONSULTING LIMITED
Steel Structure & Facade Specialist

FACADE CONSULTANT:

ARUP
ALPHA CONSULTING LIMITED
Steel Structure & Facade Specialist

- NOTE :
1. ALL DIMENSIONS ARE IN mm.
 2. ALL ELEVATIONS ARE VIEWED FROM OUTSIDE.
 3. ALL DIMENSIONS TO BE VERIFIED ON SITE BEFORE FABRICATION.

LEGEND :

(X1) --- DETAIL MARK NO.
(X001) --- REEFER SHEET NO.

1. F.F.L. --- FINISHED FLOOR LEVEL
2. S.F.L. --- STRUCTURAL FLOOR LEVEL
3. (R) --- REVERSED DETAIL

4. GLASS LEGEND

- EGL-1 --- 8mmHS+12mm AIR GAP+10mmTP THK. I.G.U.
EGL-2 --- 10mm THK. CLEAR TEMPERED GLASS
EGL-4 --- 10mm THK. TEMPERED ACID ETCHED GLASS
EGL-1A --- 8mmHS+12mm AIR GAP+8mmTP THK. I.G.U.
EGL-1B --- 8mmHS+12mm AIR GAP+10mmTP ACID-ETCHED THK. I.G.U.

NO.	DATE	REVISION	SUBJECT TO ARCH/COMMENT	BY
G	21/09/2022	REVISION	SUBJECT TO ARCH/COMMENT	hwt
F	17/07/2022	REVISION	SUBJECT TO ARCH/COMMENT	hwt
E	18/06/2022	REVISION	SUBJECT TO ARCH/COMMENT	hwt
D	09/04/2022	REVISION	SUBJECT TO ARCH/COMMENT	hwt
C	17/12/2021	REVISION	SUBJECT TO ARCH/COMMENT	hwt
B	29/11/2021	REVISION	SUBJECT TO ARCH/COMMENT	hwt
A	03/11/2021	REVISION	SUBJECT TO ARCH/COMMENT	hwt

JOB NO. : J-856

PROJECT : PROPOSED DEVELOPMENT ABOVE LIGHT RAIL TIN WING STOP TSWTL NO.23,AREA 33,TIN SHUI WAI, N.T.

TITLE : WINDOW SCHEDULE FOR TOWER 2 ALUM. WINDOW

DATE : 02-Aug-21 SCALE : 1:40

DRAWN BY : IYVN CHECKED BY :

美特鋁質有限公司
MIDI ALUMINUM FABRICATOR LTD.
Units 6-8, Sunray Industrial Centre, 1/F
610 Chee Kwo Ling Road, Kwai Tsan
Tel:23489211-4 Fax:(852)2727666
DWG NO. : JB56-SD-PW-5208 REV : G

LOCATION	OPENABLE AREA	GLAZING AREA	OPENABLE AREA	GLAZING AREA
B3-BR1	0.263	0.420	0.548	0.985

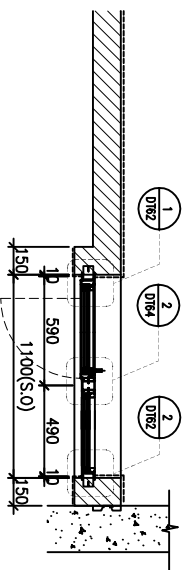
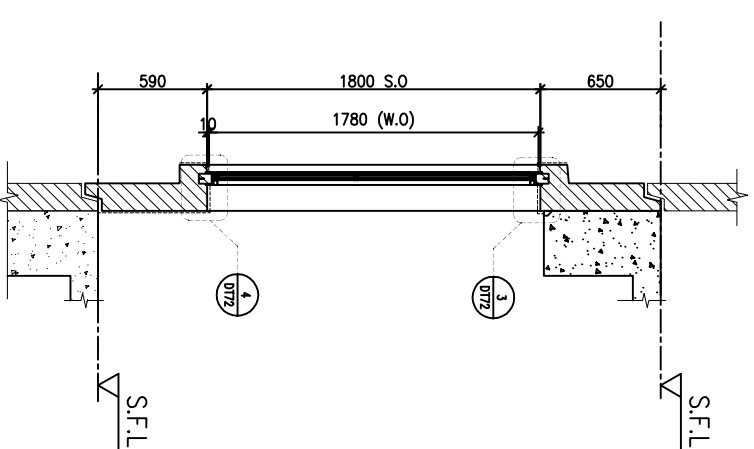
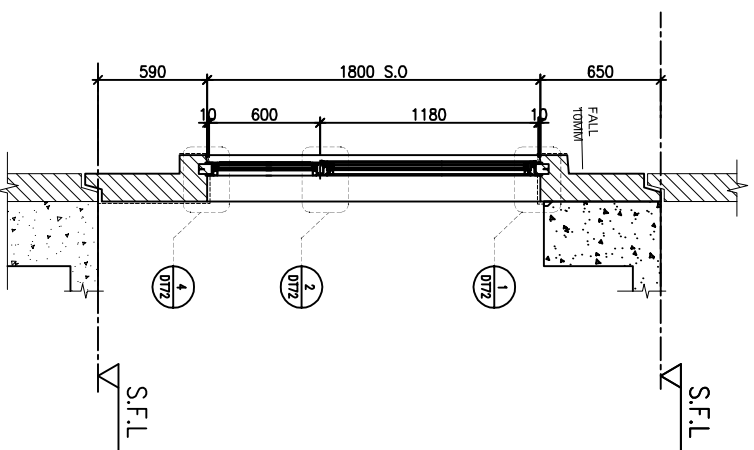
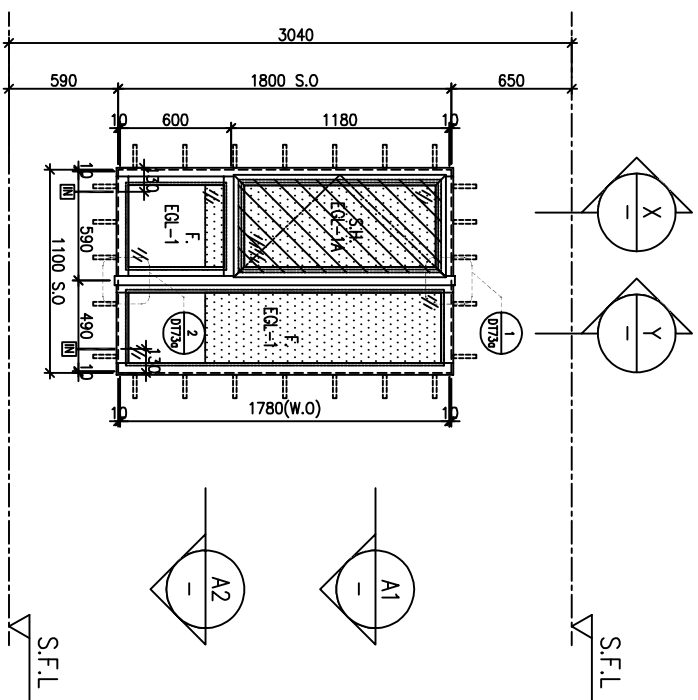

A1 PART PLAN

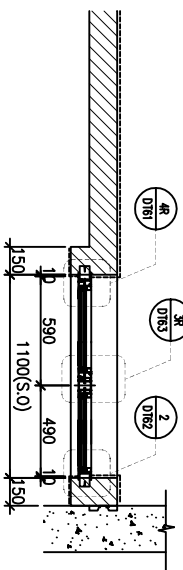

A2 PART PLAN

FACADE CODE		
LWK	鴻輝	UNIT
PF-19	T2PF-04	B3

WINDOW MARK	AW 02
LOCATION	3/F-42/F(4/F,13/F,14/F,24/F,34/F OMITTED) UNIT B3
SECTION	70mm ALUM. SECTION
GLAZING	EGL-1,EGL-1A
QUANTITY	35 Nos
REMARKS	FACADE(TYPE T1PF19 FOR 3/F-42/F) ,4 BAR HINGE-LIP HING (HHMS-N16)

BD. REF :

CLIENT :

SUN HUNG KAI
REAL ESTATE AGENCY LTD.
42/F SUN HUNG KAI CENTRE, WANCHOW, HONGKONG

ARCHITECT :

lwk&partners
a r c h i t e c t s

MAIN CONTRACTOR :

怡輝建築有限公司
Yee Fai Building Contractors Ltd.

STRUCTURAL ENGINEER :

ARUP
ALPHA CONSULTING LIMITED
Steel Structure & Façade Specialist

FACADE CONSULTANT:

ARUP
ALPHA CONSULTING LIMITED
Steel Structure & Façade Specialist

- NOTE:
1. ALL DIMENSIONS ARE IN mm.
 2. ALL ELEVATIONS ARE VIEWED FROM OUTSIDE.
 3. ALL DIMENSIONS TO BE VERIFIED ON SITE BEFORE FABRICATION.

LEGEND :

- (X1) --- DETAIL MARK NO.
(X001) --- REEFER SHEET NO.
1. F.F.L. --- FINISHED FLOOR LEVEL
 2. S.F.L. --- STRUCTURAL FLOOR LEVEL
 3. (R) --- REVERSED DETAIL

4. GLASS LEGEND

- EGL-1 --- 6mmHS+12mm AIR GAP+10mmTP THK. I.G.U.
EGL-2 --- 10mm THK. CLEAR TEMPERED GLASS
EGL-4 --- 10mm THK. TEMPERED ACID ETCHED GLASS
EGL-1A --- 6mmHS+12mm AIR GAP+8mmTP THK. I.G.U.
EGL-1B --- 6mmHS+12mm AIR GAP+10mmTP ACID-ETCHED THK. I.G.U.

NO.	DATE	REVISION	REVISION SUBJECT TO ARCH/COMMENT	BY
H	21/09/2022	REVISION SUBJECT TO ARCH/COMMENT	None	None
G	17/08/2022	REVISION SUBJECT TO ARCH/COMMENT	None	None
F	18/05/2022	REVISION SUBJECT TO ARCH/COMMENT	None	None
E	09/04/2022	REVISION SUBJECT TO ARCH/COMMENT	None	None
D	17/12/2021	REVISION SUBJECT TO ARCH/COMMENT	None	None
C	29/11/2021	REVISION SUBJECT TO ARCH/COMMENT	None	None

JOB NO. : J-856

PROJECT :

PROPOSED DEVELOPMENT ABOVE LIGHT RAIL TIN WING STOP TSWTL NO.23,AREA 33,TIN SHUI WAI, N.T.

TITLE :

WINDOW SCHEDULE FOR TOWER 2 ALUM. WINDOW

DATE : 02-Aug-21 SCALE : 1:40

DRAWN BY : IYON CHECKED BY :

美特鋁質有限公司
MIDI ALUMINUM FABRICATOR LTD.
Units 6-8, Sunray Industrial Centre, 1/F
610 Chee Kwo Ling Road, Kwai Tsing, New Territories, Hong Kong
Tel:23489211-4 Fax:(852)2727666

DWG NO. : JB56-SD-PW-5209 REV. : H

B.D. REF :

CLIENT :

SUN HUNG KAI
REAL ESTATE AGENCY LTD.
42/F SUN HUNG KAI CENTRE, WANCHOW, HONGKONG

ARCHITECT :

lwk&partners
A R C H I T E C T S

MAIN CONTRACTOR :

怡輝建築有限公司
Yee Fai Building Contractors Ltd.

STRUCTURAL ENGINEER :

ARUP

FAÇADE CONSULTANT:

ALPHA CONSULTING LIMITED
Steel Structure & Façade Specialist

ELEVATION

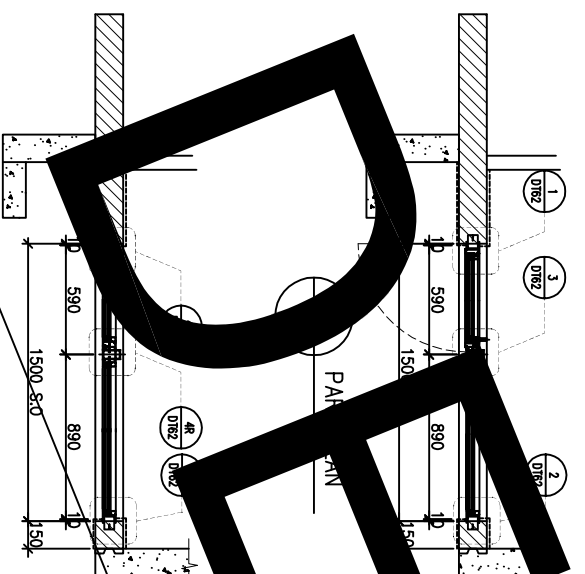
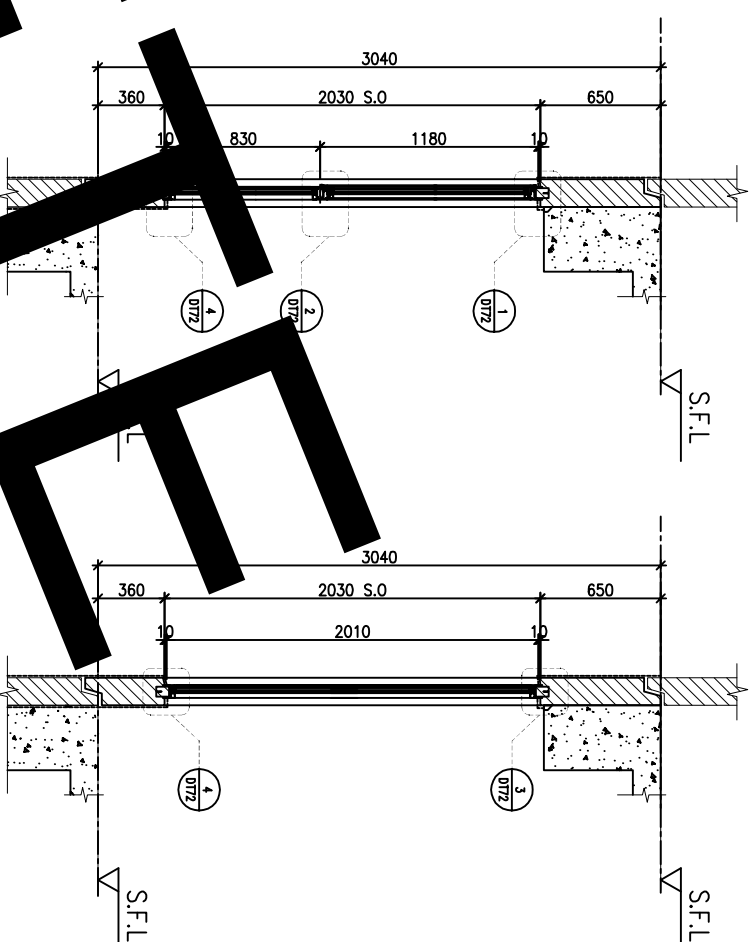
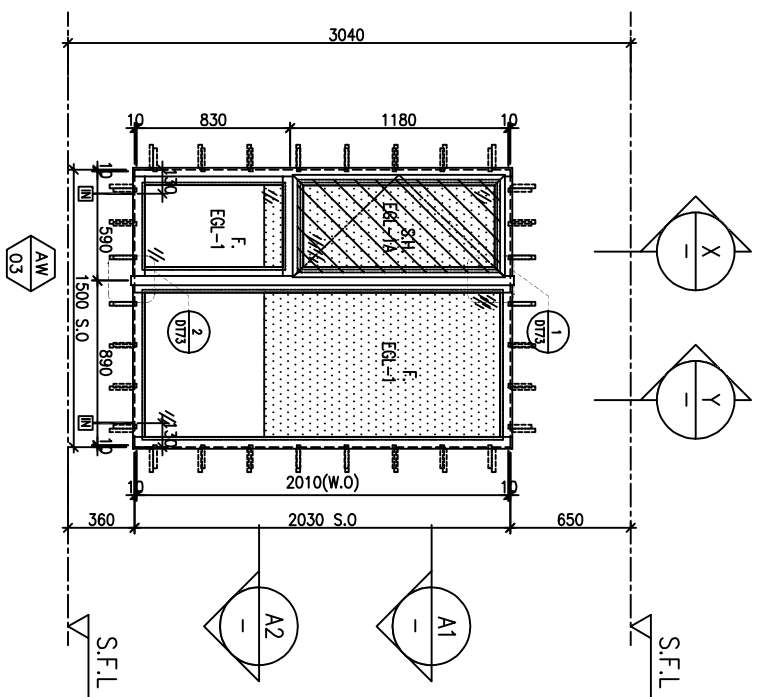

A2 PART PLAN

FAÇADE CODE		
LWK	鴻輝	UNIT
PF-11	T2PF-??	B5
CHANGE TO IN-SITU WINDOWS		

WINDOW MARK **AW 03**

LOCATION 3/F-42/F(4/F,13/F,14/F,24/F,34/F OMITTED) UNIT B5

SECTION 70mm ALUM. SECTION

GLAZING EGL-1,EGL-1A

QUANTITY 35 Nos

REMARKS FAÇADE(TYPE T2PF1) FOR 3/F-42/F)

X SECTION

Y PART SECTION

NOTE:

1. ALL DIMENSIONS ARE IN mm.
2. ALL ELEVATIONS ARE VIEWED FROM OUTSIDE.
3. ALL DIMENSIONS TO BE VERIFIED ON SITE BEFORE FABRICATION.

LEGEND:

- (X1) --- DETAIL MARK NO.
- (X001) --- REEFER SHEET NO.
- 1. F.F.L. --- FINISHED FLOOR LEVEL
- 2. S.F.L. --- STRUCTURAL FLOOR LEVEL
- 3. (R) --- REVERSED DETAIL

4. GLASS LEGEND

- EGL-1 --- 8mmHS+12mm AIR GAP+10mmTP THK. I.G.U.
- EGL-2 --- 10mm THK. CLEAR TEMPERED GLASS
- EGL-4 --- 10mm THK. TEMPERED ACID ETCHED GLASS
- EGL-1A --- 8mmHS+12mm AIR GAP+8mmTP THK. I.G.U.
- EGL-1B --- 8mmHS+12mm AIR GAP+10mmTP THK. I.G.U.
- EGL-1B --- 8mmHS+12mm AIR GAP+10mmTP THK. I.G.U.

NO.	DATE	REVISION	REVISION SUBJECT TO ARCH/COMMENT	BY
F	18/05/2022	REVISION SUBJECT TO ARCH/COMMENT	non	non
E	09/04/2022	REVISION SUBJECT TO ARCH/COMMENT	non	non
D	17/12/2021	REVISION SUBJECT TO ARCH/COMMENT	non	non
C	29/11/2021	REVISION SUBJECT TO ARCH/COMMENT	non	non
B	03/11/2021	REVISION SUBJECT TO ARCH/COMMENT	non	non
A	12/07/2021	REVISION SUBJECT TO ARCH/COMMENT	non	non

JOB NO. : J-856

PROJECT : PROPOSED DEVELOPMENT ABOVE LIGHT RAIL TIN WING STOP,T5WTL NO.23,AREA 33,TIN SHUI WAI, N.T.

TITLE : WINDOW SCHEDULE FOR TOWER 2 ALUM. WINDOW

DATE : 02-Aug-21 SCALE : 1:40

DRAWN BY : IYVN CHECKED BY :

美特鋁質有限公司
MIDI ALUMINUM FABRICATOR LTD.
Units 6-8, Sunray Industrial Centre, 1/F
610 Cho Kwai Ling Road, Kwailoon
Tel:23489211-4 Fax:(852)2727666
DWG NO. : JB56-SD-PW-5210 REV : F

LOCATION	OPENABLE AREA	GLAZING AREA	OPENABLE AREA	GLAZING AREA
B8-BR2	0.277	0.443	0.525	1.873

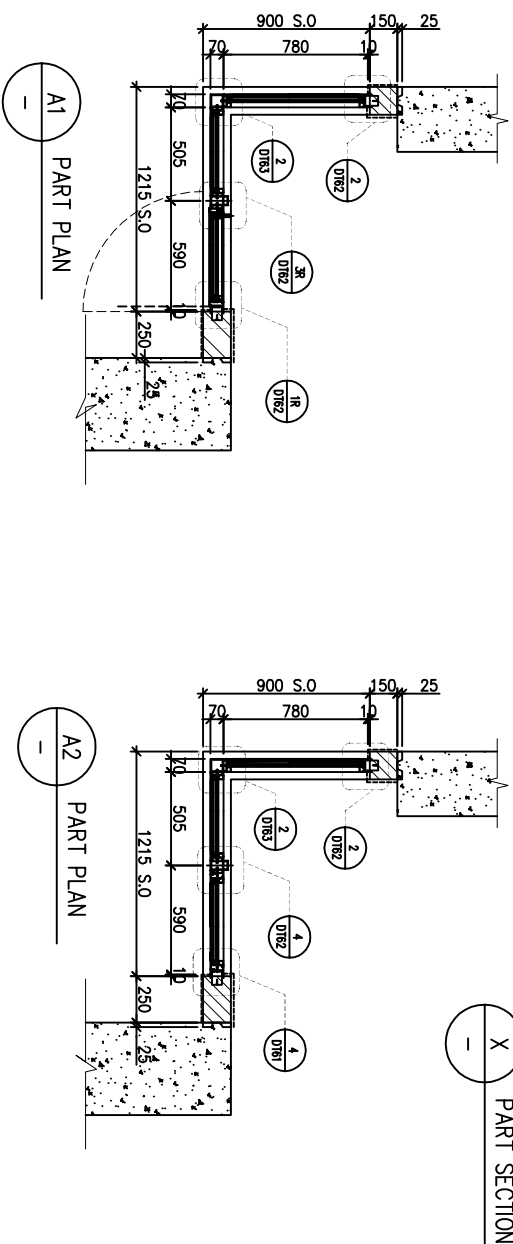
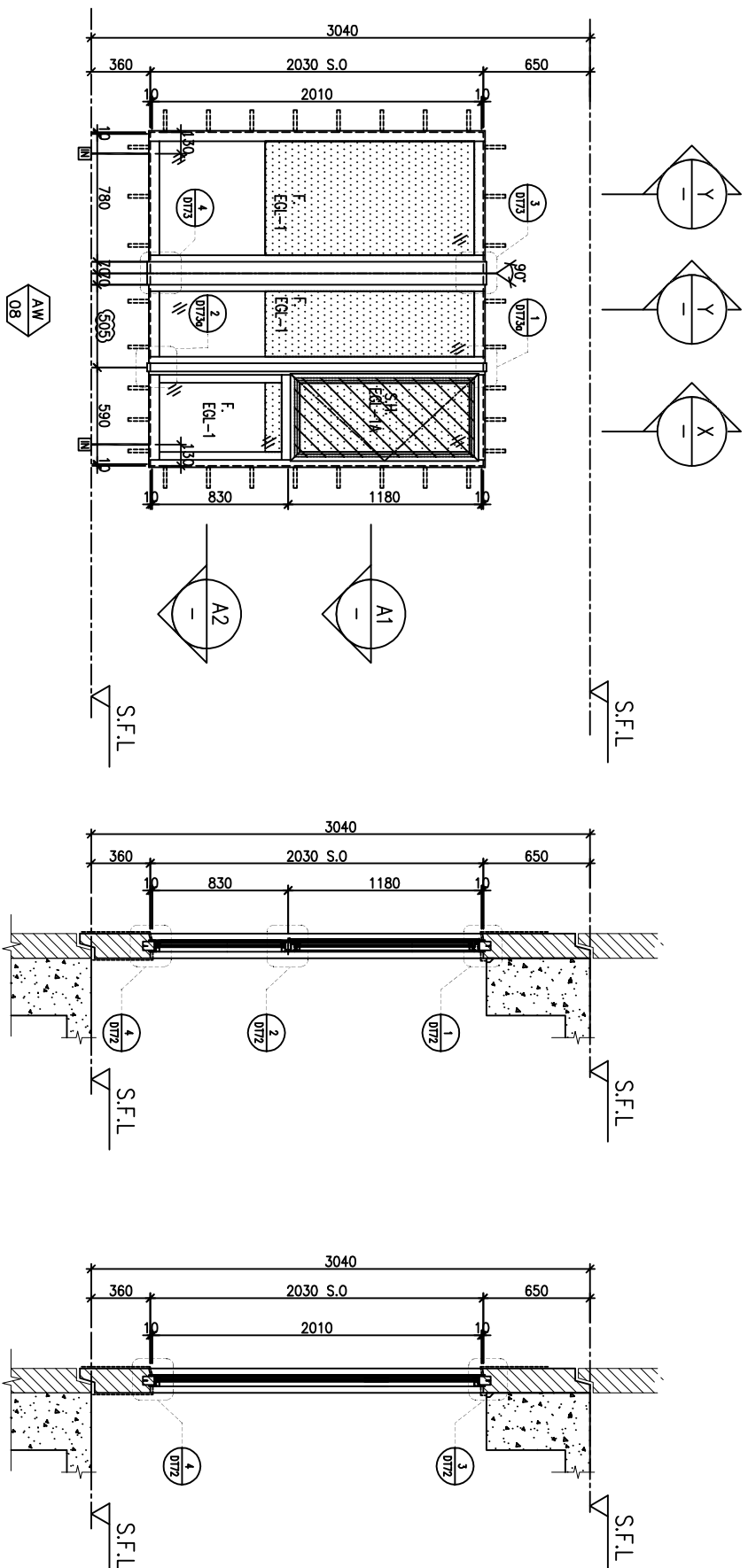

FACADE CODE		
LWK	鴻輝	UNIT
PF-13	T2PF-27	B8

WINDOW MARK	AW 08
LOCATION	3/F-42/F(4/F,13/F,14/F,24/F,34/F OMITTED) UNIT B8
SECTION	70mm ALUM. SECTION
GLAZING	EGL-1,EGL-1A
QUANTITY	35 Nos
REMARKS	FACADE(TYPE T2PF13 FOR 3/F-42/F) ,4 BAR HINGE-LIP HING (HHMS-N16)

BD. REF :

CLIENT :

SUN HUNG KAI
REAL ESTATE AGENCY LTD.
42/F SUN HUNG KAI CENTRE, WANCHAI, HONGKONG

ARCHITECT :

lwk&partners
A R C H I T E C T S

MAIN CONTRACTOR :

怡輝建築有限公司
Yee Fai Building Contractors Ltd.

STRUCTURAL ENGINEER :

ARUP
ALPHA CONSULTING LIMITED
Steel Structure & Façade Specialist

FACADE CONSULTANT:

ARUP
ALPHA CONSULTING LIMITED
Steel Structure & Façade Specialist

NOTE :

1. ALL DIMENSIONS ARE IN mm.
2. ALL ELEVATIONS ARE VIEWED FROM OUTSIDE.
3. ALL DIMENSIONS TO BE VERIFIED ON SITE BEFORE FABRICATION.

LEGEND :

- (X1) --- DETAIL MARK NO.
- (X001) --- REEFER SHEET NO.
- 1. F.F.L. --- FINISHED FLOOR LEVEL
- 2. S.F.L. --- STRUCTURAL FLOOR LEVEL
- 3. (R) --- REVERSED DETAIL
- 4. GLASS LEGEND

EGL-1 --- 8mmHS+12mm AIR GAP+10mmTP THK. I.G.U.
EGL-2 --- 10mm THK. CLEAR TEMPERED GLASS
EGL-4 --- 10mm THK. TEMPERED ACID ETCHED GLASS
EGL-1A --- 8mmHS+12mm AIR GAP+8mmTP THK. I.G.U.
EGL-1B --- 8mmHS+12mm AIR GAP+10mmTP ACID-ETCHED THK. I.G.U.

NO.	DATE	REVISION	REVISION SUBJECT TO ARCH/COMMENT	BY
H	17/08/2022	REVISION SUBJECT TO ARCH/COMMENT		HW
G	17/08/2022	REVISION SUBJECT TO ARCH/COMMENT		HW
F	18/05/2022	REVISION SUBJECT TO ARCH/COMMENT		HW
E	09/04/2022	REVISION SUBJECT TO ARCH/COMMENT		HW
D	17/12/2021	REVISION SUBJECT TO ARCH/COMMENT		HW
C	29/11/2021	REVISION SUBJECT TO ARCH/COMMENT		HW

JOB NO. : J-856

PROJECT : PROPOSED DEVELOPMENT ABOVE LIGHT RAIL TIN WING STOP,TSWTL NO.23,AREA 33,TIN SHUI WAI, N.T.

TITLE : WINDOW SCHEDULE FOR TOWER 2 ALUM. WINDOW

DATE : 02-Aug-21 SCALE : 1:40

DRAWN BY : IYVN CHECKED BY :

美特鋁質有限公司
MIDI ALUMINUM FABRICATOR LTD.
Units 6-8, Sunray Industrial Centre, 1/F
610 Chee Kwo Ling Road, Kwai Tsing
Tel:23489211-4 Fax:(852)2727666
DWG NO. : JB56-SD-PW-5211 REV. : H

LOCATION	OPENABLE AREA	GLAZING AREA	OPENABLE AREA	GLAZING AREA
B6-MBR	0.435	0.696	0.548	1.495

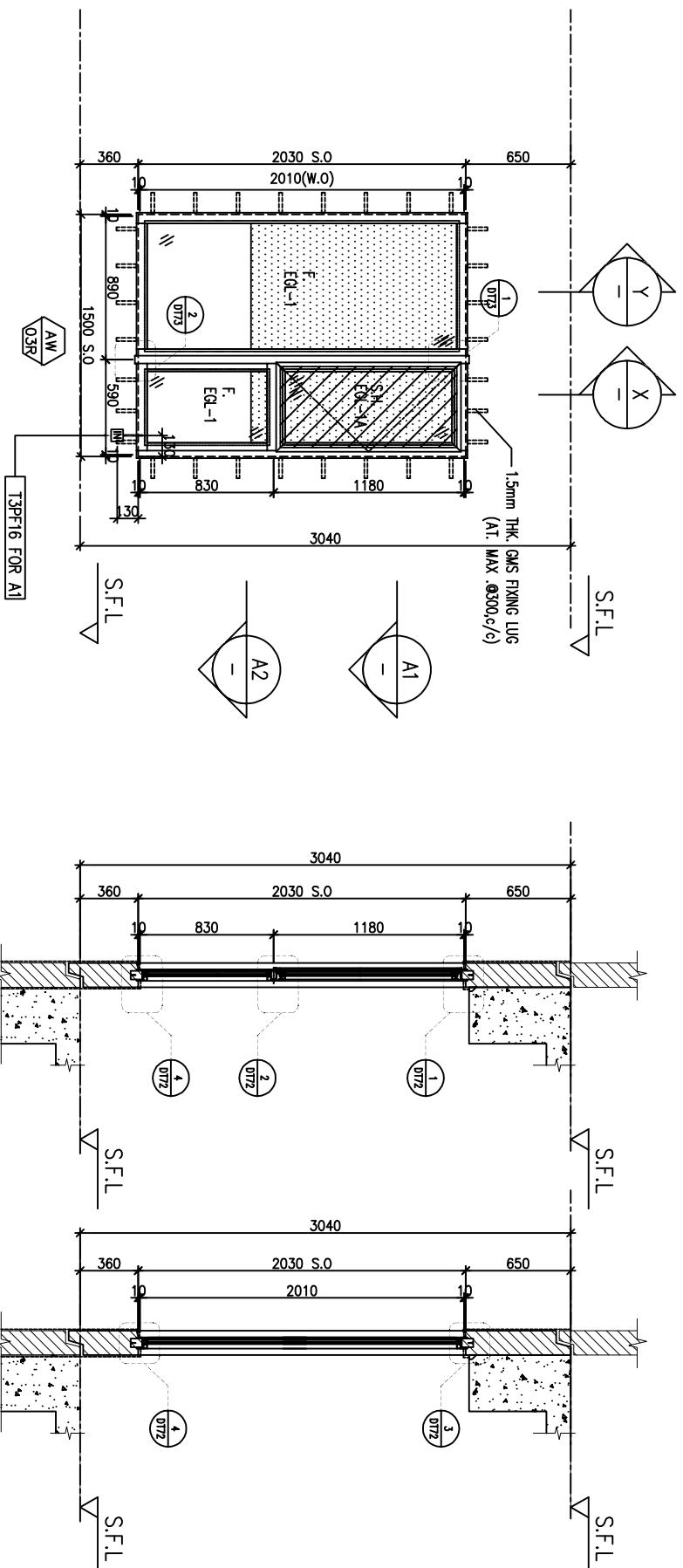

ELEVATION

FACADE CODE		
LWK	鴻輝	UNIT
PF-20R	T2PF-23	B6

WINDOW MARK	AW 03R
LOCATION	3/F-42/F(4/F,13/F,14/F,24/F,34/F OMITTED) UNIT B6
SECTION	70mm ALUM. SECTION
GLAZING	EGL-1, EGL-1A
QUANTITY	35 Nos
REMARKS	FACADE(TYPE T2PF20R FOR 3/F~42/F), 4 BAR HINGE-LIP HING (HHMS-N16)

B.D. REF :

CLIENT :

SUN HUNG KAI
REAL ESTATE AGENCY LTD.
42/F SUN HUNG KAI CENTRE, WANCHAI, HONGKONG

ARCHITECT :

lwk&partners
ARCHITECTS

MAIN CONTRACTOR :

怡輝建築有限公司
Yee Fai
Building Contractors Ltd.

STRUCTURAL ENGINEER :

ARUP
ALPHA CONSULTING LIMITED
Steel Structure & Façade Specialist

FACADE CONSULTANT :

ARUP
ALPHA CONSULTING LIMITED
Steel Structure & Façade Specialist

NOTE :

1. ALL DIMENSIONS ARE IN mm.
2. ALL ELEVATIONS ARE VIEWED FROM OUTSIDE.
3. ALL DIMENSIONS TO BE VERIFIED ON SITE BEFORE FABRICATION.

LEGEND :

(X1) --- DETAIL MARK NO.
(X001) --- REEFER SHEET NO.

1. F.F.L. --- FINISHED FLOOR LEVEL
2. S.F.L. --- STRUCTURAL FLOOR LEVEL
3. (R) --- REVERSED DETAIL

4. GLASS LEGEND

- EQ-1 --- 8mmHS+12mm AIR GAP+10mmTP THK. I.G.U.
- EQ-2 --- 10mm THK. CLEAR TEMPERED GLASS
- EQ-4 --- 10mm THK. TEMPERED ACID ETCHED GLASS
- EQ-1A --- 8mmHS+12mm AIR GAP+8mmTP THK. I.G.U.
- EQ-1B --- 8mmHS+12mm AIR GAP+10mmTP ACID-ETCHED THK. I.G.U.

NO.	DATE	REVISION	REVISION SUBJECT TO ARCH/COMMENT	BY
D	17/08/2022	REVISION SUBJECT TO ARCH/COMMENT		HW
C	17/08/2022	REVISION SUBJECT TO ARCH/COMMENT		HW
B	18/05/2022	REVISION SUBJECT TO ARCH/COMMENT		HW
A	17/12/2021	REVISION SUBJECT TO ARCH/COMMENT		HW

JOB NO. : J-856

PROJECT : PROPOSED DEVELOPMENT ABOVE LIGHT RAIL TIN WING STOP-TSWTL NO.23,AREA 33,TIN SHUI WAI, N.T.

TITLE : WINDOW SCHEDULE FOR TOWER 2 ALUM. WINDOW

DATE : 02-Aug-21 SCALE : 1:40

DRAWN BY : IYVN CHECKED BY :

美特鋁質有限公司
MIDI ALUMINUM FABRICATOR LTD.
Units 6-8, Sunray Industrial Centre, 1/F
610 Chee Kwo Ling Road, Kowloon
Tel:23489211-4 Fax:(852)2727666
DWG NO. : J856-SD-PW-5212 REV : D

LOCATION	OPENABLE AREA	GLAZING AREA	OPENABLE AREA	GLAZING AREA
B3-BR1	0.263	0.420	0.548	1.495

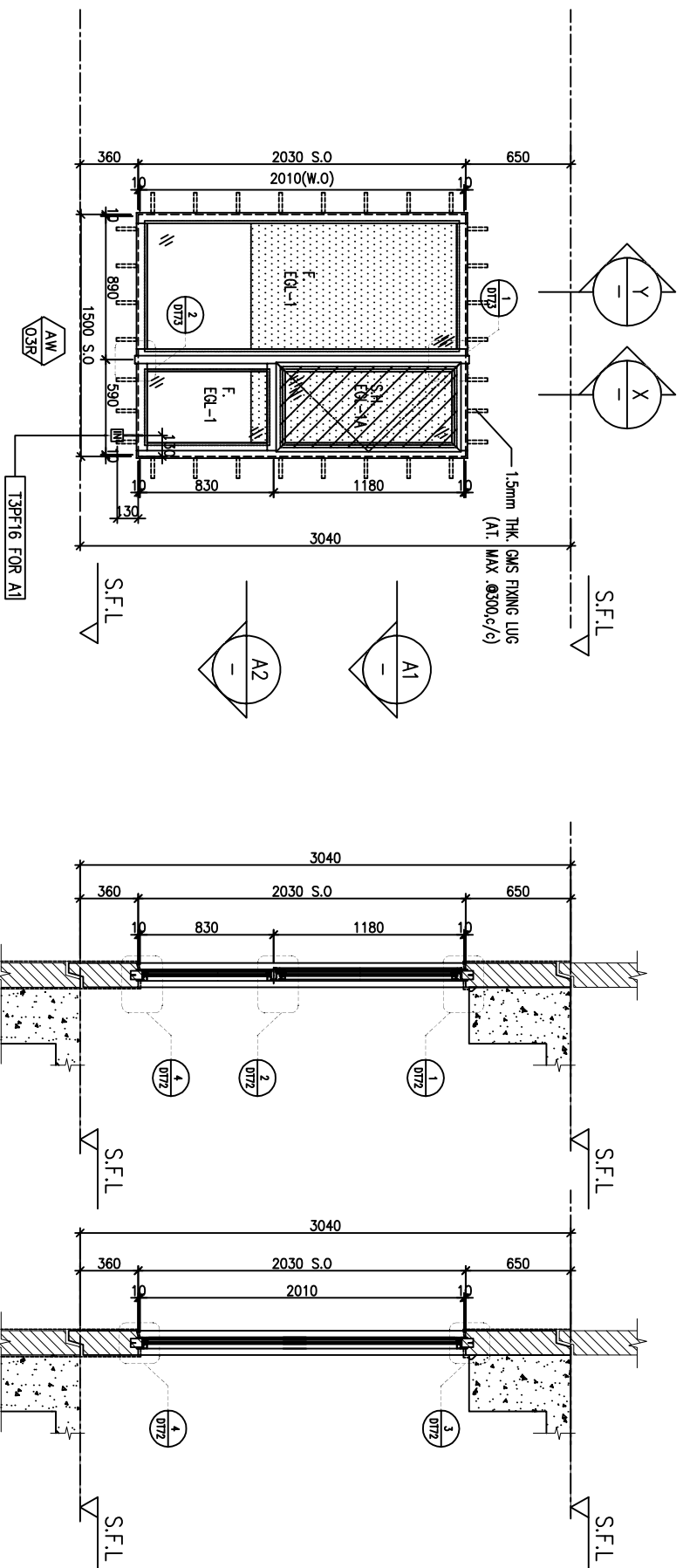

ELEVATION

FACADE CODE		
LWK	鴻輝	UNIT
PF-10	T2PF-03	B3



WINDOW MARK	3/F-42/F(4/F,13/F,14/F,24/F,34/F OMITTED) UNIT B3
LOCATION	70mm ALUM. SECTION
SECTION	EGL-1, EGL-1A
GLAZING	35 Nos
QUANTITY	FACADE(TYPE T2PF10R FOR 3/F~42/F) , 4 BAR HINGE-LIP HING (HHMS-N16)
REMARKS	

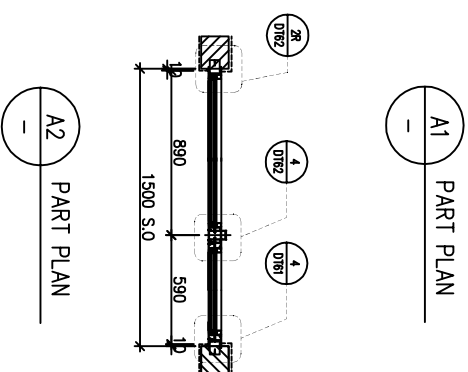

A1 PART PLAN

X PART SECTION

Y PART SECTION

NO.	DATE	REVISION	REVISION SUBJECT TO ARCH/COMMENT	BY
C	21/09/2022	REVISION SUBJECT TO ARCH/COMMENT		HW
B	17/09/2022	REVISION SUBJECT TO ARCH/COMMENT		HW
A	18/09/2022	REVISION SUBJECT TO ARCH/COMMENT		HW

JOB NO. : J-856

PROJECT :
PROPOSED DEVELOPMENT ABOVE
LIGHT RAIL TIN WING STOP-TSWTL
NO.23,AREA 33,TIN SHUI WAI, N.T.

TITLE :
WINDOW SCHEDULE FOR
TOWER 2 ALUM. WINDOW

DATE : 08-Apr-21 SCALE : 1:40
DRAWN BY : IYON CHECKED BY :

美特铝质有限公司
MIDI ALUMINUM FABRICATOR LTD.
Units 6-8, Sunray Industrial Centre, 1/F
610 Chee Kwo Ling Road, Kowloon
Tel:23489211-4 Fax:(852)2727666
DWG NO. : JB56-SD-PW-5213 REV : C

B.D. REF :

CLIENT :

SUN HUNG KAI
REAL ESTATE AGENCY LTD.
42/F SUN HUNG KAI CENTRE, WANCHAI, HONGKONG

ARCHITECT :

lwk&partners
A R C H I T E C T S

MAIN CONTRACTOR :

怡輝建築有限公司
Yee Fai Building Contractors Ltd.

STRUCTURAL ENGINEER :

ARUP
ALPHA CONSULTING LIMITED
Steel Structure & Façade Specialist

FACADE CONSULTANT:

ARUP
ALPHA CONSULTING LIMITED
Steel Structure & Façade Specialist

NOTE :

1. ALL DIMENSIONS ARE IN mm.
2. ALL ELEVATIONS ARE VIEWED FROM OUTSIDE.
3. ALL DIMENSIONS TO BE VERIFIED ON SITE BEFORE FABRICATION.

LEGEND :

Ø11 --- DETAIL MARK NO.
Ø1001 --- REEFER SHEET NO.

1. F.F.L. --- FINISHED FLOOR LEVEL
2. S.F.L. --- STRUCTURAL FLOOR LEVEL
3. (R) --- REVERSED DETAIL

4. GLASS LEGEND

EQ-1 --- 6mmHS+12mm AIR GAP+10mmTP THK. I.G.U.
EQ-2 --- 10mm THK. CLEAR TEMPERED GLASS
EQ-4 --- 10mm THK. TEMPERED ACID ETCHED GLASS
EQ-1A --- 6mmHS+12mm AIR GAP+8mmTP THK. I.G.U.
EQ-1B --- 6mmHS+12mm AIR GAP+10mmTP THK. I.G.U.
10mmTP ACID-ETCHED THK. I.G.U.

REQUIRE		PROVIDED	
LOCATION	OPENABLE AREA	GLAZING AREA	OPENABLE AREA
B2-MBR	0.435	0.696	0.548
			GLAZING AREA
			1.24

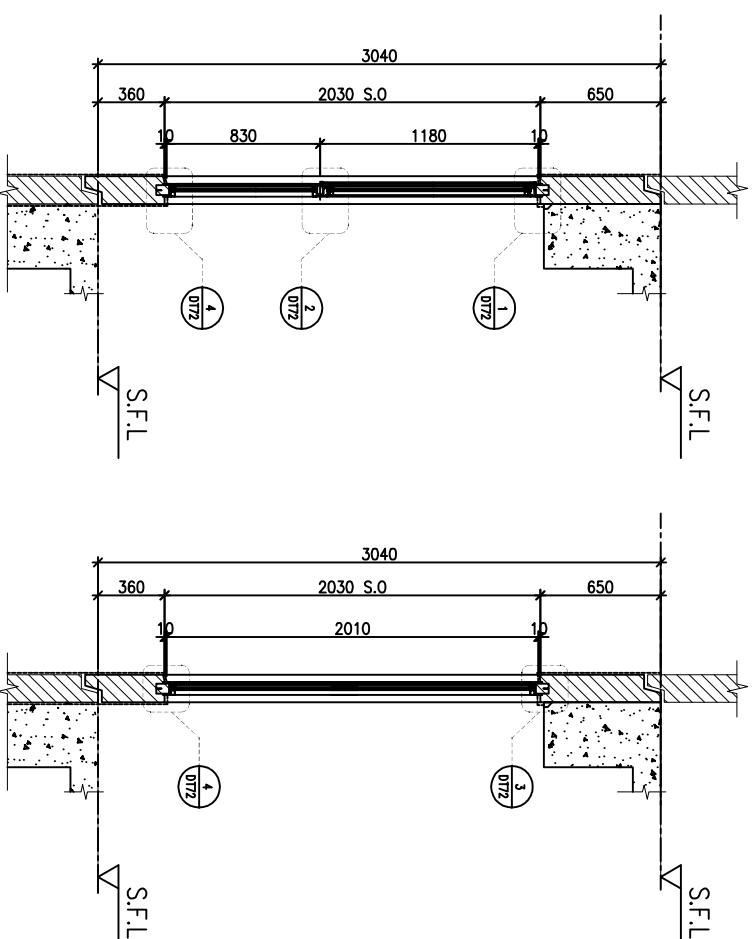
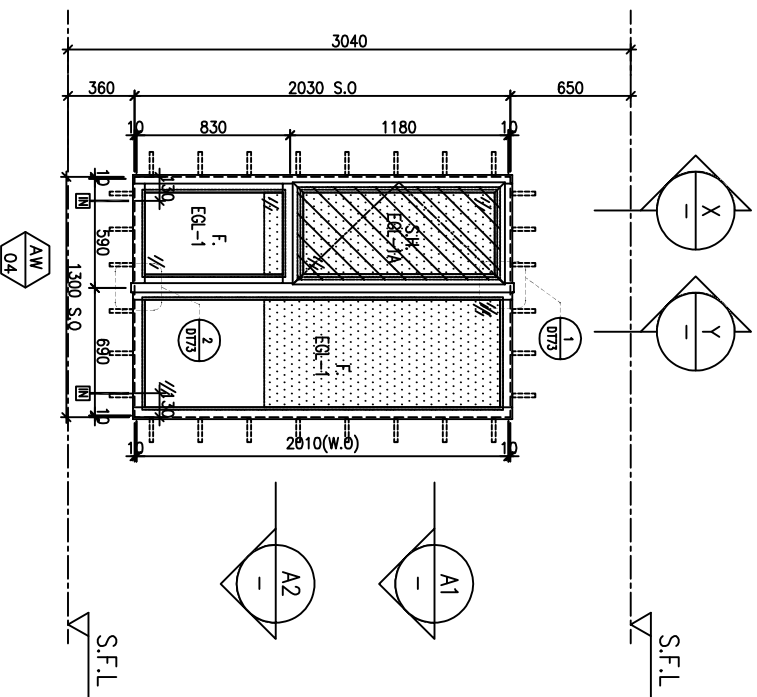

ELEVATION

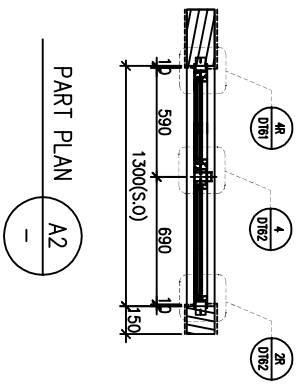
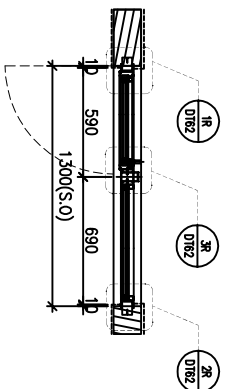

FACADE CODE		
LWK	鴻輝	UNIT
PF-??R	T2PF-02A	B2

WINDOW MARK	AW 04
LOCATION	3/F-42/F(4/F,13/F,14/F,24/F,34/F OMITTED) UNIT B2
SECTION	70mm ALUM. SECTION
GLAZING	EGL-1, EGL-1A
QUANTITY	35 Nos
REMARKS	FACADE(TYPE T2PF??R FOR 3/F~42/F) , 4 BAR HINGE-LIP HING (HHMS-N16)

BD. REF :

CLIENT :

SUN HUNG KAI
REAL ESTATE AGENCY LTD.
42/F SUN HUNG KAI CENTRE, WANCHAI, HONGKONG

ARCHITECT :

lwk&partners
ARCHITECTS

MAIN CONTRACTOR :

怡輝建築有限公司
Yee Fai Building Contractors Ltd.

STRUCTURAL ENGINEER :

ARUP
ALPHA CONSULTING LIMITED
Steel Structure & Façade Specialist

FACADE CONSULTANT:

ARUP
ALPHA CONSULTING LIMITED
Steel Structure & Façade Specialist

- NOTE :
1. ALL DIMENSIONS ARE IN mm.
 2. ALL ELEVATIONS ARE VIEWED FROM OUTSIDE.
 3. ALL DIMENSIONS TO BE VERIFIED ON SITE BEFORE FABRICATION.

LEGEND :

(X1) --- DETAIL MARK NO.
(X001) --- REEFER SHEET NO.

1. F.F.L. --- FINISHED FLOOR LEVEL
2. S.F.L. --- STRUCTURAL FLOOR LEVEL
3. (R) --- REVERSED DETAIL

4. GLASS LEGEND

- EGL-1 --- 8mmHS+12mm AIR GAP+10mmTP THK. I.G.U.
EGL-2 --- 10mm THK. CLEAR TEMPERED GLASS
EGL-4 --- 10mm THK. TEMPERED ACID ETCHED GLASS
EGL-1A --- 8mmHS+12mm AIR GAP+8mmTP THK. I.G.U.
EGL-1B --- 8mmHS+12mm AIR GAP+10mmTP ACID-ETCHED THK. I.G.U.

NO.	DATE	REVISION	REVISION SUBJECT TO ARCH/COMMENT	BY
D	21/09/2022	REVISION SUBJECT TO ARCH/COMMENT		ivan
C	17/09/2022	REVISION SUBJECT TO ARCH/COMMENT		ivan
B	18/05/2022	REVISION SUBJECT TO ARCH/COMMENT		ivan
A	17/12/2021	REVISION SUBJECT TO ARCH/COMMENT		ivan

JOB NO. : J-856

PROJECT :

PROPOSED DEVELOPMENT ABOVE LIGHT RAIL TIN WING STOP-TSWTL NO.23,AREA 33,TIN SHUI WAI, N.T.

TITLE :

WINDOW SCHEDULE FOR TOWER 2 ALUM. WINDOW

DATE : 08-Apr-21 SCALE : 1:40

DRAWN BY : ivan CHECKED BY :

美特鋁質有限公司
MIDI ALUMINUM FABRICATOR LTD.
Units 6-8, Sunray Industrial Centre, 1/F
610 Chee Kwo Ling Road, Kwai Tsoum
Tel:23489211-4 Fax:(852)2727666

DWG NO. : JB56-SD-PW-5214 REV. : D

REQUIRE		PROVIDED	
LOCATION	OPENABLE AREA	GLAZING AREA	GLAZING AREA
A2-BR1	0.263	0.420	0.548
A9-BR1	0.263	0.420	0.985
B7-BR1	0.263	0.420	
B8-BR1	0.263	0.420	

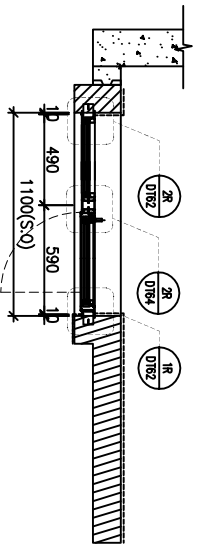
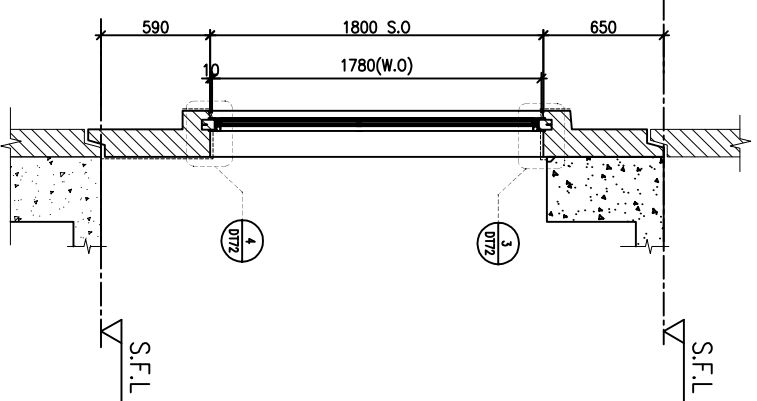
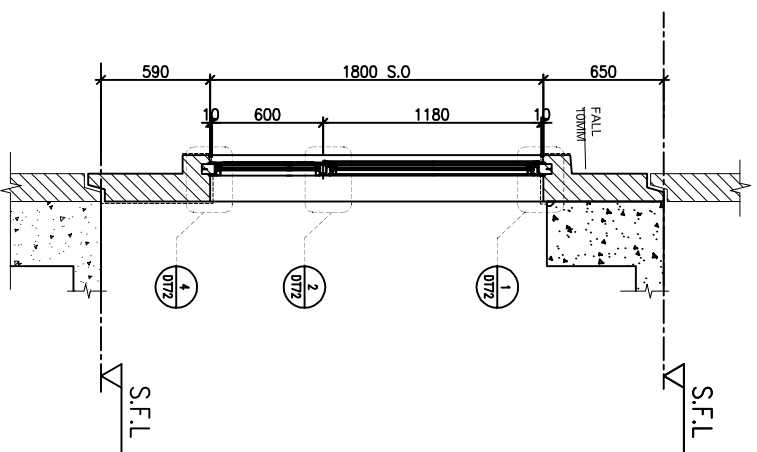
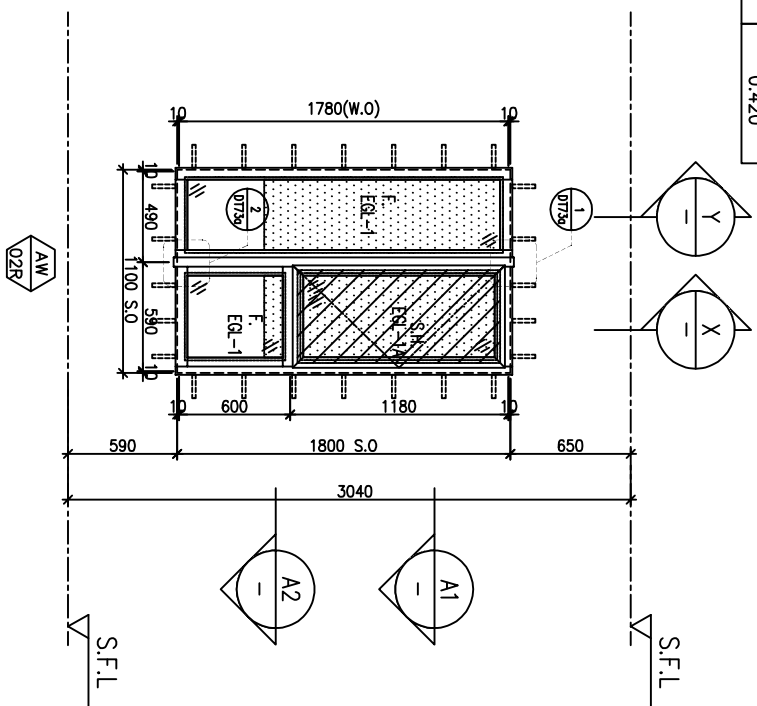

A1 PART PLAN

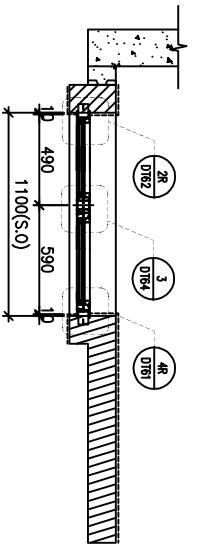

A2 PART PLAN

10/F, 16/F, 20/F, 25/F, 29/F, 33/F, 38/F, 42/F OMITTED, CHANGE TO IN-SITU WINDOW

FAÇADE CODE	UNIT
LWK	鴻輝
PF-02R	T3PF-05
PF-02R	T3PF-37
PF-02R	T3PF-31
PF-02R	T3PF-32

WINDOW MARK	UNIT
AW 02R	B6

LOCATION 3/F-42/F(4/F, 13/F, 14/F, 24/F, 34/F OMITTED) UNIT {A3, A10, B7, B6}

SECTION 70mm ALUM. SECTION

GLAZING EGL-1, EGL-1A

QUANTITY 27 Nos / 35 Nos / 35 Nos / 35 Nos

REMARKS FAÇADE(TYPE T3PF02R FOR 3/F-42/F), 4 BAR HINGE-LIP HING (HHMS-N16)

X PART SECTION

Y PART SECTION

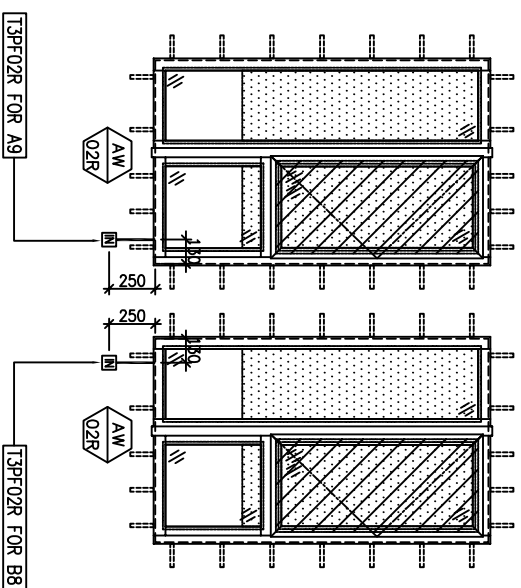

BD. REF : _____

CLIENT : **SUN HUNG KAI**
REAL ESTATE AGENCY LTD.
42/F SUN HUNG KAI CENTRE, WANCHAI, HONGKONG

ARCHITECT : **lwk&partners**
a r c h i t e c t s

MAIN CONTRACTOR : **怡輝建築有限公司**
Yee Fai Building Contractors Ltd.

STRUCTURAL ENGINEER : **ARUP**
ALPHA CONSULTING LIMITED
Steel Structure & Façade Specialist

FAÇADE CONSULTANT : **ARUP**

NOTE :

- ALL DIMENSIONS ARE IN mm.
- ALL ELEVATIONS ARE VIEWED FROM OUTSIDE.
- ALL DIMENSIONS TO BE VERIFIED ON SITE BEFORE FABRICATION.

LEGEND :

X1 --- DETAIL MARK NO.
X2001 --- REEFER SHEET NO.

- F.F.L. --- FINISHED FLOOR LEVEL
- S.F.L. --- STRUCTURAL FLOOR LEVEL
- R --- REVERSED DETAIL

4. GLASS LEGEND

EGL-1 --- 6mmHS+12mm AIR GAP+10mmTP THK. I.G.U.
EGL-2 --- 10mm THK. CLEAR TEMPERED GLASS
EGL-4 --- 10mm THK. TEMPERED ACID ETCHED GLASS
EGL-1A --- 6mmHS+12mm AIR GAP+8mmTP THK. I.G.U.
EGL-1B --- 6mmHS+12mm AIR GAP+10mmTP ACID-ETCHED THK. I.G.U.

NO.	DATE	REVISION	BY
J	26/10/2022	REVISION SUBJECT REFER TO SH-1324	hw
I	21/09/2022	REVISION SUBJECT TO ARCH/COMMENT	hw
H	17/08/2022	REVISION SUBJECT TO ARCH/COMMENT	hw
G	22/04/2022	REVISION SUBJECT TO ARCH/COMMENT	hw
F	09/04/2022	REVISION SUBJECT TO ARCH/COMMENT	hw
E	14/12/2021	REVISION SUBJECT TO ARCH/COMMENT	hw
D	29/11/2021	REVISION SUBJECT TO ARCH/COMMENT	hw

JOB NO. : J-856

PROJECT : PROPOSED DEVELOPMENT ABOVE LIGHT RAIL TIN WING STOP,T3WTL NO.23,AREA 33,TIN SHUI WAI, N.T.

TITLE : WINDOW SCHEDULE FOR TOWER 3 ALUM. WINDOW

DATE : 02-Aug-21 SCALE : 1:40

DRAWN BY : IYVN CHECKED BY :

UNITED STATES OF AMERICA

美特鋁質有限公司
MIDI ALUMINUM FABRICATOR LTD.
Units 6-8, Sunray Industrial Centre, 1/F
610 Chee Kwoi Ling Road, Kwai Tsoum
Tel:23489211-4 Fax:(852)2727666
DWG NO. : JB56-SD-PW-5301 REV : J

REQUIRED		PROVIDED	
LOCATION	OPENABLE AREA	GLAZING AREA	GLAZING AREA
A3-MBR	0.435	0.696	0.548
A6-MBR	0.435	0.696	
A10-MBR	0.435	0.696	
A12-MBR	0.388	0.620	
B5-MBR	0.435	0.696	
B9-MBR	0.388	0.620	
B11-MBR	0.435	0.696	

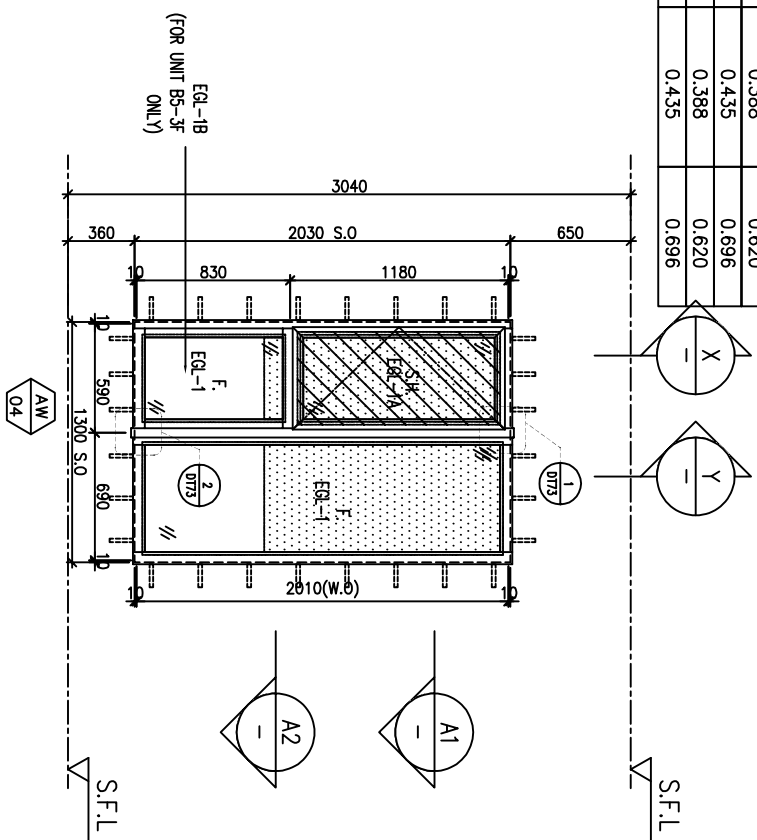

ELEVATION

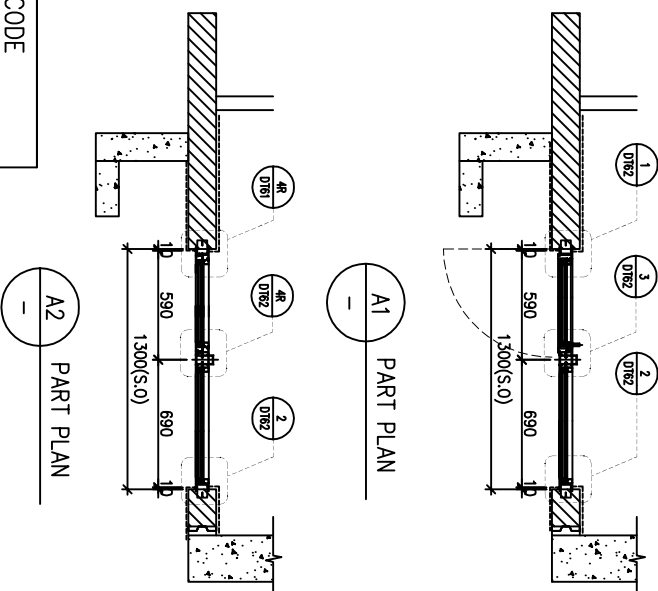

FACADE CODE		FACADE CODE	
LWK	UNIT	LWK	UNIT
PF-04	T3PF-08	PF-04	T3PF-26
PF-04	T3PF-12	PF-04	T3PF-33
PF-04	T3PF-39A	PF-04R	T3PF-19
PF-04	T3PF-42		

LOCATION	3/F-42/F(4/F,13/F,14/F,24/F,34/F OMITTED)	UNIT	A5, A7, A11, A13, B9, B5, B2
SECTION	70mm ALUM. SECTION		
GLAZING	EGL-1, EGL-1A		
QUANTITY	35 Nos / 35 Nos / 35 Nos / 35 Nos / 35 Nos / 35 Nos		
REMARKS	FACADE(TYPE T3PF04/04R FOR 3/F~42/F), 4 BAR HINGE-LIP HING (HHMS-N16)		

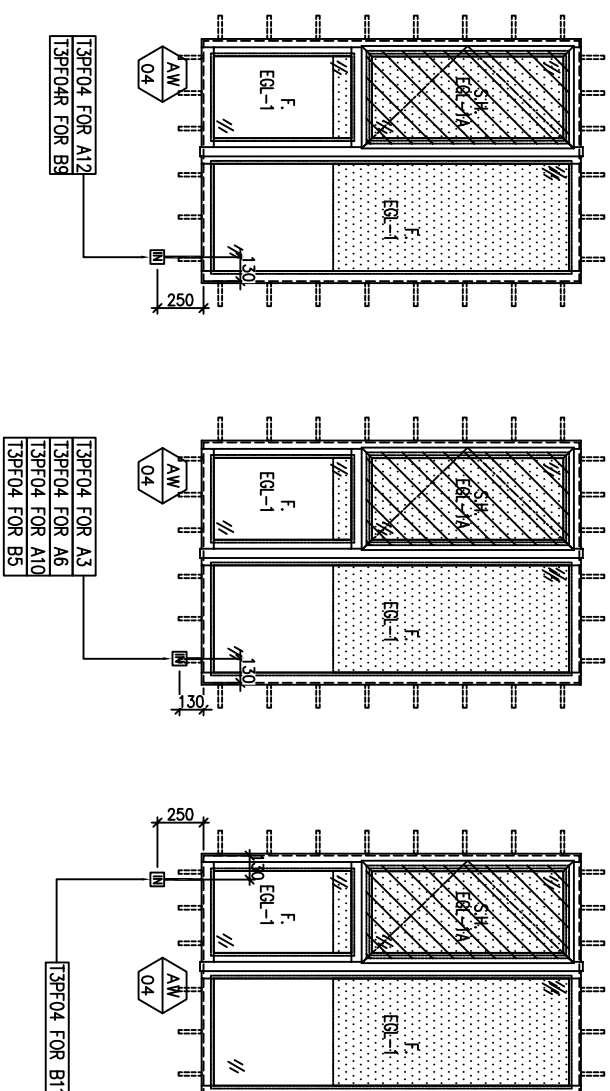
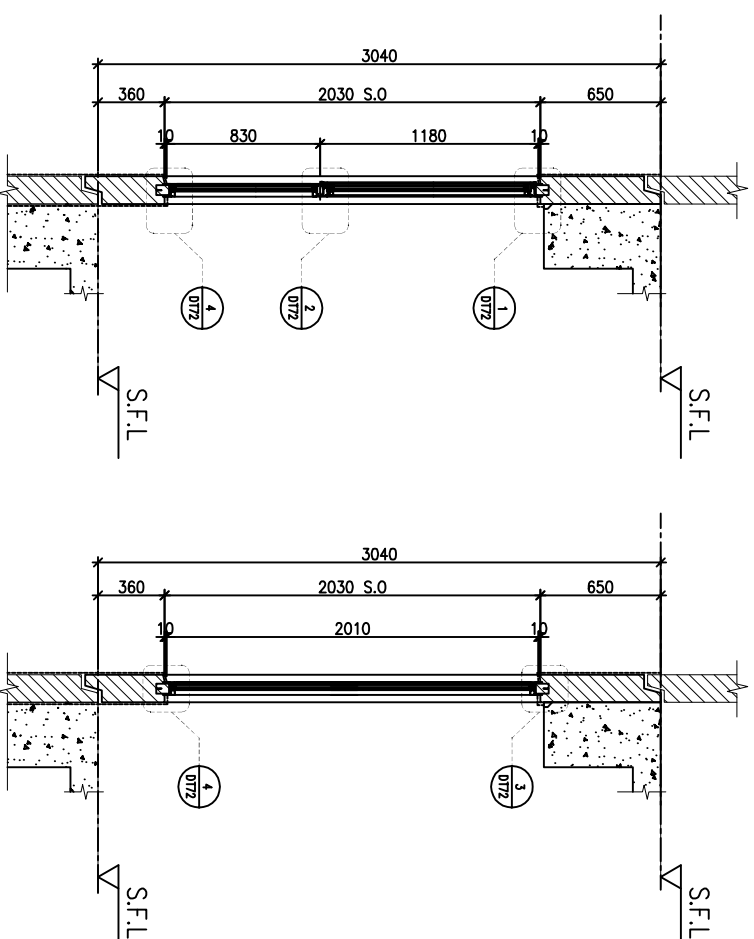

X PART SECTION

Y PART SECTION

BD. REF : _____

CLIENT : **SUN HUNG KAI**
REAL ESTATE AGENCY LTD.
42/F SUN HUNG KAI CENTRE, WANCHAI, HONGKONG

ARCHITECT : **lwk&partners**
a r c h i t e c t s

MAIN CONTRACTOR : **怡輝建築有限公司**
Yee Fai Building Contractors Ltd.

STRUCTURAL ENGINEER : **ARUP**
ALPHA CONSULTING LIMITED
Steel Structure & Façade Specialist

NOTE:
1. ALL DIMENSIONS ARE IN mm.
2. ALL ELEVATIONS ARE VIEWED FROM OUTSIDE.
3. ALL DIMENSIONS TO BE VERIFIED ON SITE BEFORE FABRICATION.

LEGEND:

X1 --- DETAIL MARK NO.
X2001 --- REER SHEET NO.

1. F.F.L. --- FINISHED FLOOR LEVEL
2. S.F.L. --- STRUCTURAL FLOOR LEVEL
3. (R) --- REVERSED DETAIL

4. GLASS LEGEND
EQ1-1 --- 8mmHS+12mm AIR GAP+10mmTP THK. I.G.U.
EQ1-2 --- 10mm THK. CLEAR TEMPERED GLASS
EQ1-4 --- 10mm THK. TEMPERED ACID ETCHED GLASS
EQ1-1A --- 8mmHS+12mm AIR GAP+8mmTP THK. I.G.U.
EQ1-1B --- 8mmHS+12mm AIR GAP+10mmTP ACID-ETCHED THK. I.G.U.

NO.	DATE	REVISION	BY
L	26/10/2022	REVISION SUBJECT TO GEP PLAN	h
K	21/09/2022	REVISION SUBJECT TO ARCH/COMMENT	h
J	17/08/2022	REVISION SUBJECT TO ARCH/COMMENT	h
I	27/06/2022	REVISION SUBJECT TO ARCH/COMMENT	h
H	22/04/2022	REVISION SUBJECT TO ARCH/COMMENT	h
G	09/04/2022	REVISION SUBJECT TO ARCH/COMMENT	h
F	14/2/2021	REVISION SUBJECT TO ARCH/COMMENT	h

JOB NO. : J-856
PROJECT : PROPOSED DEVELOPMENT ABOVE LIGHT RAIL TIN WING STOP TSWTL NO.23, AREA 33, TIN SHUI WAI, N.T.
TITLE : WINDOW SCHEDULE FOR TOWER 3 ALUM. WINDOW

DATE : 02-Aug-21
SCALE : 1:40
DRAWN BY : IYON
CHECKED BY :

美特鋁質有限公司
MIDI ALUMINIUM FABRICATOR LTD.
Units 6-8, Sunray Industrial Centre, 1/F
610 Chee Kwo Ling Road, Kwai Tsing
Tel: 23489211-4 Fax: (852) 2727666
DWG NO. : JB56-SD-PW-5302 REV : L

LOCATION	OPENABLE AREA	GLAZING AREA	OPENABLE AREA	GLAZING AREA
A1-S10	N/A	N/A	0.548	0.985
A6-BR1	0.263	0.420		
A10-BR1	0.263	0.420		
A11-BR1	0.263	0.420		
B5-BR1	0.263	0.420		
B9-BR1	0.263	0.420		
B11-BR1	0.263	0.420		

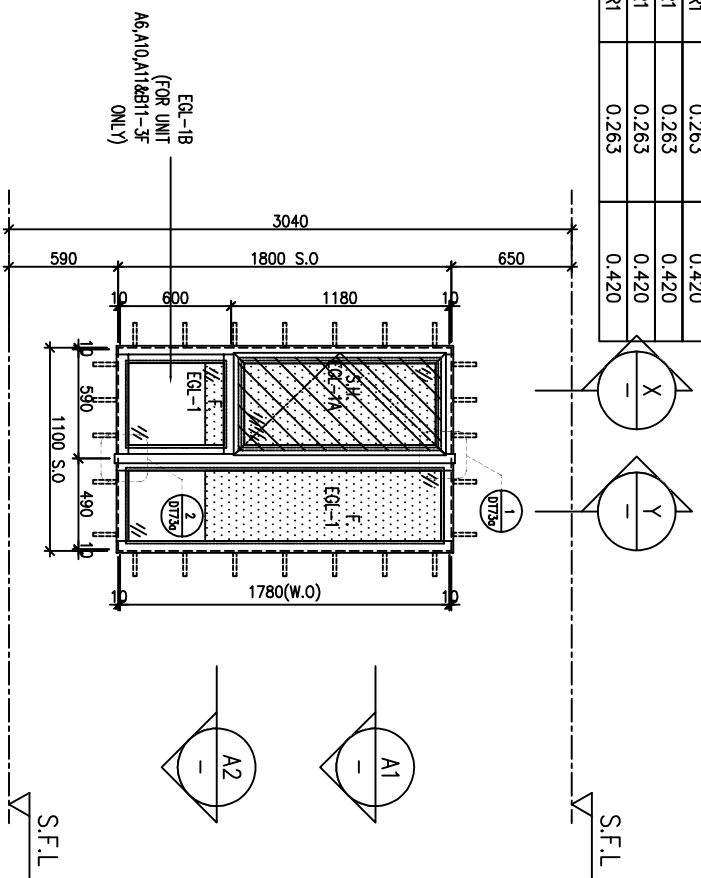

ELEVATION

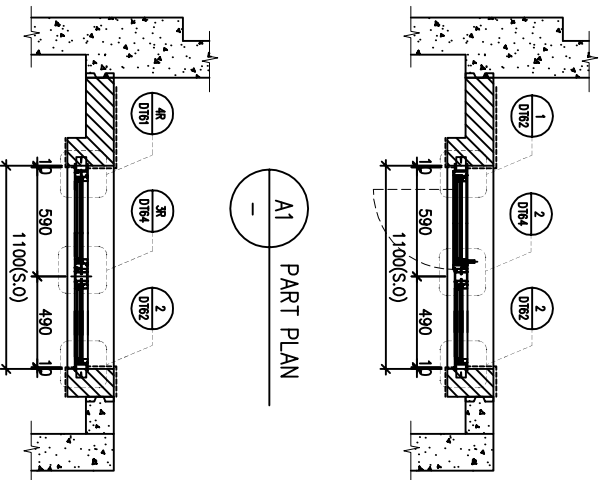

A2 PART PLAN

FAÇADE CODE	UNIT	FAÇADE CODE	UNIT
LWK 鴻輝	A2	LWK 鴻輝	A7
PF-05	T3PF-04	PF-05	T3PF-27
PF-05	T3PF-13	PF-05	T3PF-34
PF-05	T3PF-39	PF-05	T3PF-18
PF-05	T3PF-40		B2

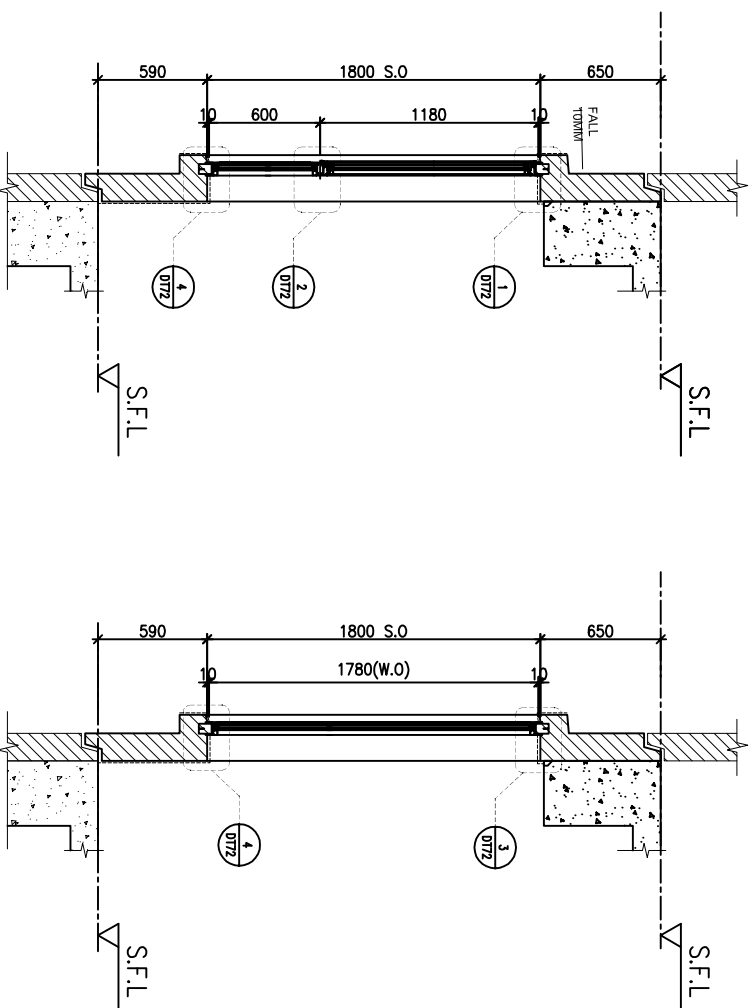

X PART SECTION

Y PART SECTION

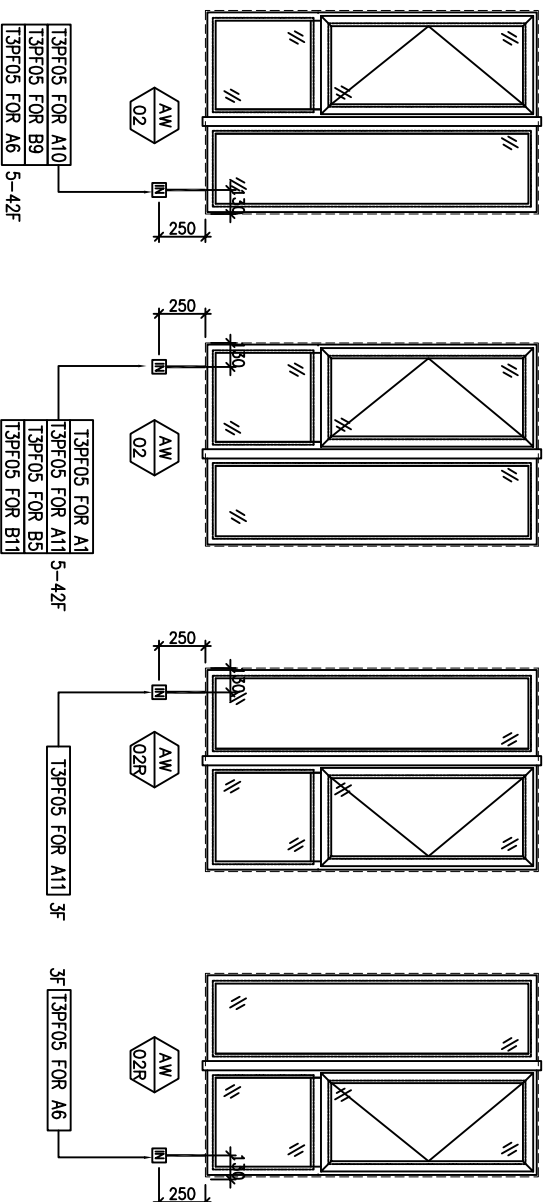

LOCATION	3/F~42/F(4/F,13/F,14/F,24/F,34/F OMITTED)	UNIT	A2, A7, A11, A12(5-42F), B9, B5, B2(5-42F)
SECTION	70mm ALUM. SECTION		
GLAZING	EGL-1, EGL-1A		
QUANTITY	35 Nos / 35 Nos / 35 Nos / 34 Nos / 35 Nos / 35 Nos / 34 Nos		
REMARKS	FAÇADE(TYPE T3PF05 FOR 3/F~42/F), 4 BAR HINGE-LIP HING (HHMS-N16)		

B.D. REF :

CLIENT : SUN HUNG KAI REAL ESTATE AGENCY LTD. 42/F SUN HUNG KAI CENTRE, WANCHAI, HONGKONG

ARCHITECT : **lwk&partners** ARCHITECTS

MAIN CONTRACTOR : 怡輝建築有限公司 Yee Fai Building Contractors Ltd.

STRUCTURAL ENGINEER : **ARUP** ALPHA CONSULTING LIMITED Steel Structure & Facade Specialist

FAÇADE CONSULTANT :

ARUP ALPHA CONSULTING LIMITED Steel Structure & Facade Specialist

- NOTE :
1. ALL DIMENSIONS ARE IN mm.
 2. ALL ELEVATIONS ARE VIEWED FROM OUTSIDE.
 3. ALL DIMENSIONS TO BE VERIFIED ON SITE BEFORE FABRICATION.

LEGEND :

- (X1) --- DETAIL MARK NO.
- (X001) --- REEFER SHEET NO.
- 1. F.F.L. --- FINISHED FLOOR LEVEL
- 2. S.F.L. --- STRUCTURAL FLOOR LEVEL
- 3. (R) --- REVERSED DETAIL

4. GLASS LEGEND

- EQ-1--8mmHS+12mm AIR GAP+10mmTP THK. I.G.U.
- EQ-2--10mm THK. CLEAR TEMPERED GLASS
- EQ-4--10mm THK. TEMPERED ACID ETCHED GLASS
- EQ-1A--8mmHS+12mm AIR GAP+8mmTP THK. I.G.U.
- EQ-1B--8mmHS+12mm AIR GAP+10mmTP ACID-ETCHED THK. I.G.U.

NO.	DATE	REVISION	BY
L	26/10/2022	REVISION SUBJECT TO GRP PLAN	h
K	21/09/2022	REVISION SUBJECT TO ARCH/COMMENT	h
J	17/08/2022	REVISION SUBJECT TO ARCH/COMMENT	h
I	27/06/2022	REVISION SUBJECT TO ARCH/COMMENT	h
H	22/04/2022	REVISION SUBJECT TO ARCH/COMMENT	h
G	08/04/2022	REVISION SUBJECT TO ARCH/COMMENT	h
F	14/12/2021	REVISION SUBJECT TO ARCH/COMMENT	h

JOB NO. : J-856

PROJECT : PROPOSED DEVELOPMENT ABOVE LIGHT RAIL TIN WING STOP,TSWTL NO.23,AREA 33,TIN SHUI WAI, N.T.

TITLE : WINDOW SCHEDULE FOR TOWER 3 ALUM. WINDOW

DATE : 02-Aug-21 SCALE : 1:40

DRAWN BY : Ivan CHECKED BY :

美特鋁質有限公司 MIDT ALUMINUM FABRICATOR LTD. Units 6-8, Sunray Industrial Centre, 1/F 610 Chee Kwo Ling Road, Kowloon Tel:23489211-4 Fax:6527272666 DWG NO. : 1856-SD-PW-5303 REV : L

REQUIRE		PROVIDED	
LOCATION	OPENABLE AREA	GLAZING AREA	OPENABLE AREA
B3-BR2	0.283	0.452	0.439
B1-BR2	0.283	0.452	1.19

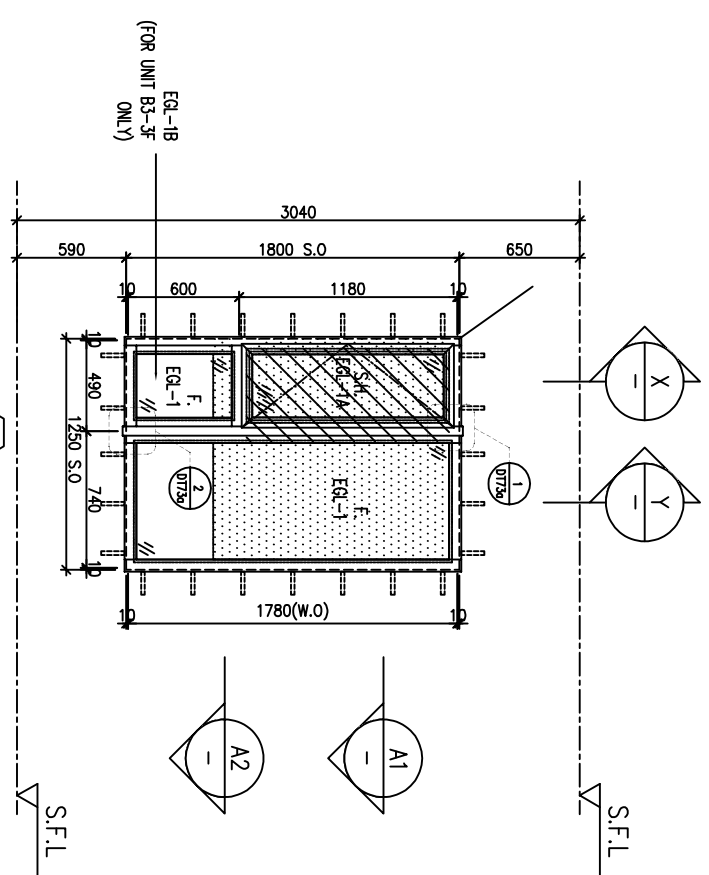

ELEVATION

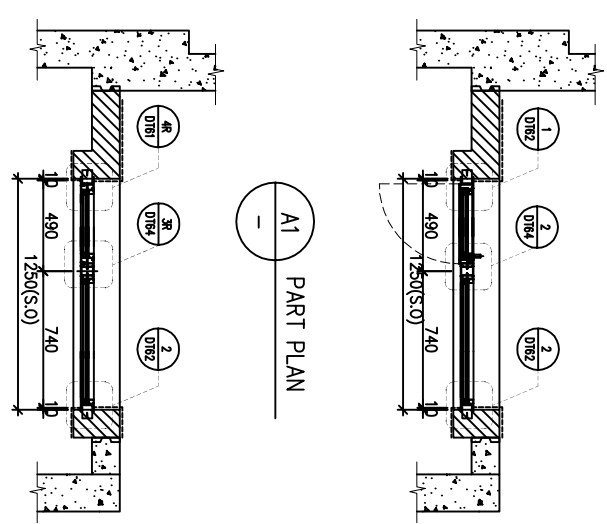
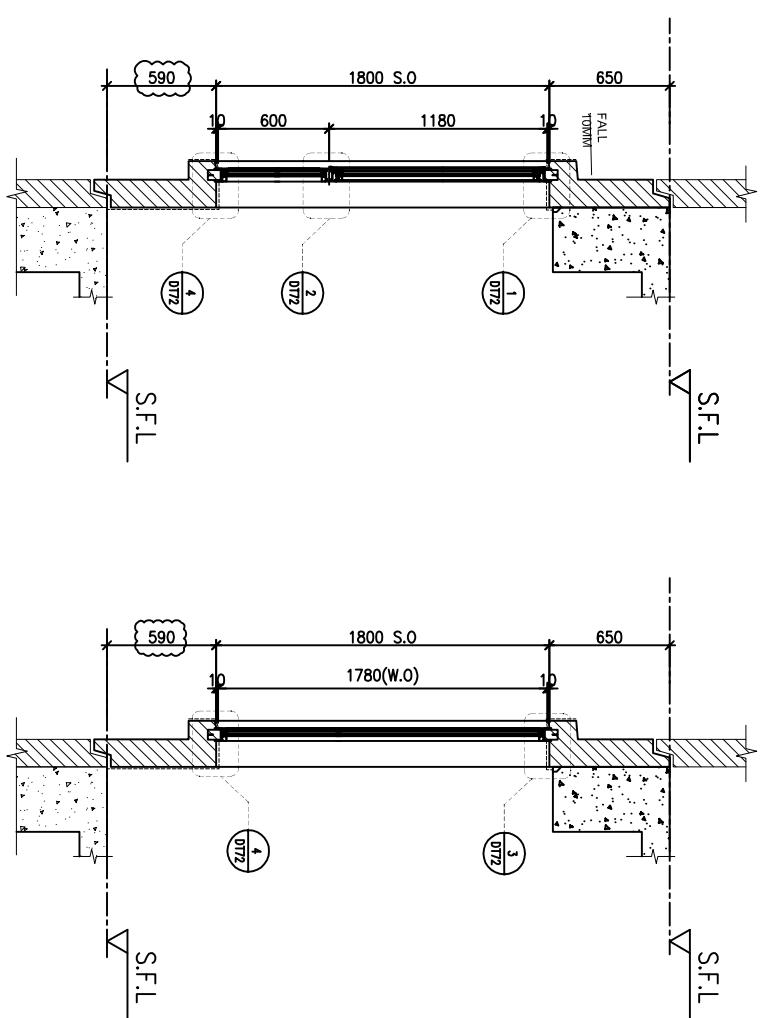

FACADE CODE		
LWK	鴻輝	UNIT
PF-05	T3PF-24	B10
PF-05R	T3PF-21	B1

WINDOW MARK	AM 02d	AM 02aB
LOCATION	3/F-42/F(4/F,13/F,14/F,24/F,34/F OMITTED) UNIT B10	3/F-42/F(4/F,13/F,14/F,24/F,34/F OMITTED) UNIT B1
SECTION	70mm ALUM. SECTION	70mm ALUM. SECTION
GLAZING	EGL-1,EGL-1A	EGL-1,EGL-1A
QUANTITY	35 Nos	35 Nos
REMARKS	FACADE(TYPE T3PF05 FOR 3/F~42/F) ,4 BAR HINGE-LIP HING (HHMS-N12	FACADE(TYPE T3PF05R FOR 3/F~42/F) ,4 BAR HINGE-LIP HING (HHMS-N12)

BD. REF :

CLIENT :

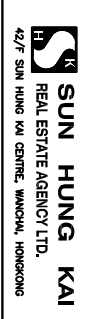

ARCHITECT :

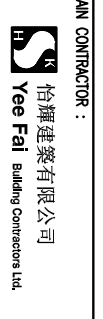

MANU CONTRACTOR :



STRUCTURAL ENGINEER :

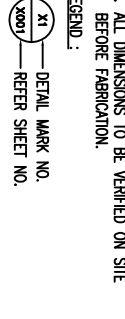

FACADE CONSULTANT :

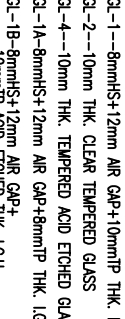

NOTE :

1. ALL DIMENSIONS ARE IN mm.
2. ALL ELEVATIONS ARE VIEWED FROM OUTSIDE.
3. ALL DIMENSIONS TO BE VERIFIED ON SITE BEFORE FABRICATION.

LEGEND :

X1	DETAIL MARK NO.
X001	REFER SHEET NO.

4. GLASS LEGEND

1. F.F.L. --- FINISHED FLOOR LEVEL
2. S.F.L. --- STRUCTURAL FLOOR LEVEL
3. (R) --- REVERSED DETAIL

5. GLASS LEGEND

- EQI-1 --- 8mmHS+12mm AIR GAP+10mmTP THK. I.G.U.
- EQI-2 --- 10mm THK. CLEAR TEMPERED GLASS
- EQI-4 --- 10mm THK. TEMPERED ACID ETCHED GLASS
- EQI-1A --- 8mmHS+12mm AIR GAP+8mmTP THK. I.G.U.
- EQI-1B --- 8mmHS+12mm AIR GAP+10mmTP ACID-ETCHED THK. I.G.U.

JOB NO. : J-856

PROJECT :

PROPOSED DEVELOPMENT ABOVE LIGHT RAIL TIN WING STOP,T5WTL NO.23,AREA 33,TIN SHUI WAI, N.T.

TITLE : WINDOW SCHEDULE FOR TOWER 3 ALUM. WINDOW

DATE : 22-Apr-22 SCALE : 1:40

DRAWN BY : IYON CHECKED BY :

UNIT 6-8, Sunray Industrial Centre, 1/F, 610 Chee Kwo Ling Road, Kowloon

TEL: 23489211-4 Fax: (852) 2727666

DWG NO. : 1856-SD-PW-5303d REV. : D

B.D. REF :

CLIENT :

SUN HUNG KAI
REAL ESTATE AGENCY LTD.
42/F SUN HUNG KAI CENTRE, WANCHAI, HONGKONG

ARCHITECT :

lwk&partners
a r c h i t e c t s

MAIN CONTRACTOR :

怡輝建築有限公司
Yee Fai
Building Contractors Ltd.

STRUCTURAL ENGINEER :

ARUP

FAÇADE CONSULTANT :

ALPHA CONSULTING LIMITED
Steel Structure & Façade Specialist

ELEVATION

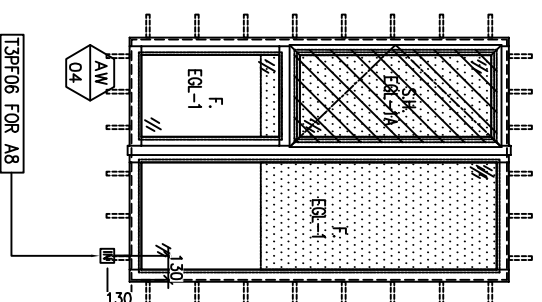
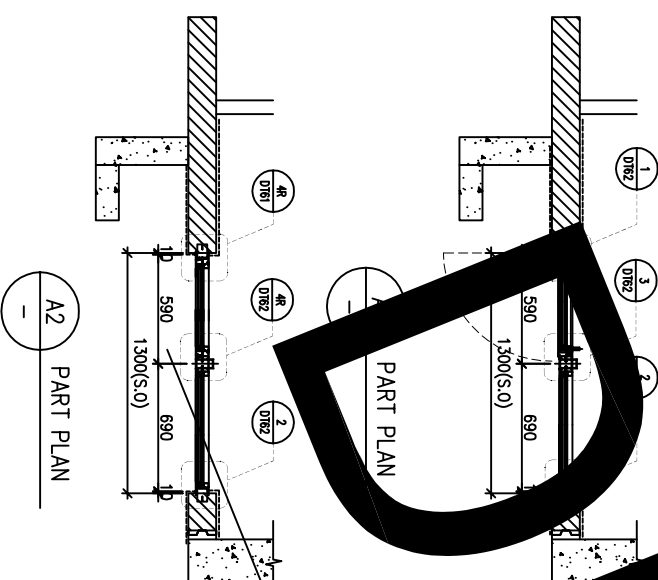
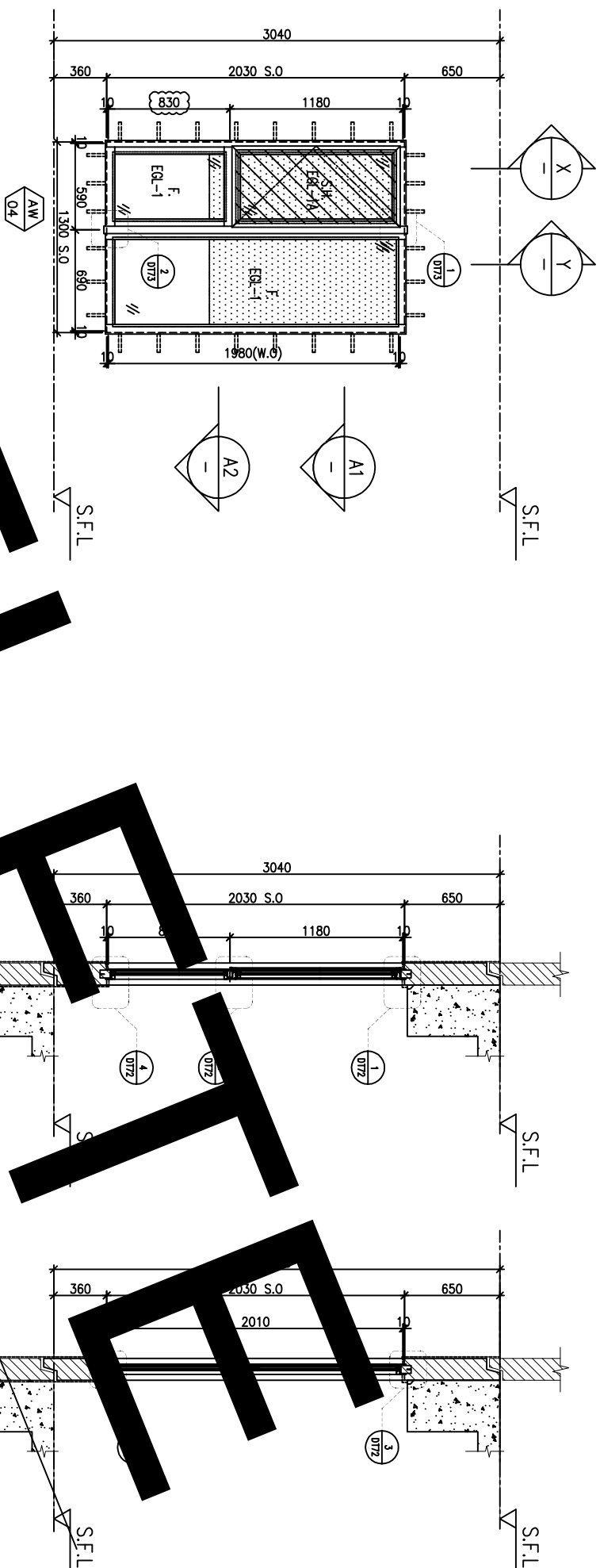

FAÇADE CODE		
LWK	錫輝	UNIT
PF-06	T3PF-36	A8

WINDOW MARK	AW 04
LOCATION	3/F-42/F(4/F,13/F,14/F,24/F,34/F OMITTED) UNIT A8
SECTION	70mm ALUM. SECTION
GLAZING	EGL-1,EGL-1A
QUANTITY	35 Nos
REMARKS	FAÇADE(TYPE T3PF06 FOR 3/F-42/F)

DRAFT

NOTE :
 1. ALL DIMENSIONS ARE IN mm.
 2. ALL ELEVATIONS ARE VIEWED FROM OUTSIDE.
 3. ALL DIMENSIONS TO BE VERIFIED ON SITE BEFORE FABRICATION.
LEGEND :
 (X1) --- DETAIL MARK NO.
 (X001) --- REEFER SHEET NO.
 1. F.F.L. --- FINISHED FLOOR LEVEL
 2. S.F.L. --- STRUCTURAL FLOOR LEVEL
 3. (R) --- REVERSED DETAIL
 4. GLASS LEGEND
 EGL-1 --- 6mmHS+12mm AIR GAP+10mmTP THK. I.G.U.
 EGL-2 --- 10mm THK. CLEAR TEMPERED GLASS
 EGL-4 --- 10mm THK. TEMPERED ACID ETCHED GLASS
 EGL-1A --- 6mmHS+12mm AIR GAP+8mmTP THK. I.G.U.
 EGL-1B --- 8mmHS+12mm AIR GAP+10mmTP ACID-ETCHED THK. I.G.U.

NO.	DATE	REVISION	REVISION SUBJECT TO ARCH/COMMENT	BY
1	27/06/2022	REVISION SUBJECT TO ARCH/COMMENT	HW	
2	22/04/2022	REVISION SUBJECT TO ARCH/COMMENT	HW	
3	09/04/2022	REVISION SUBJECT TO ARCH/COMMENT	HW	
4	14/12/2021	REVISION SUBJECT TO ARCH/COMMENT	HW	
5	29/11/2021	REVISION SUBJECT TO ARCH/COMMENT	HW	

JOB NO. : J-856
 PROJECT : PROPOSED DEVELOPMENT ABOVE LIGHT RAIL TIN WING STOP,T3WTL NO.23,AREA 33,TIN SHUI WAI, N.T.
 TITLE : WINDOW SCHEDULE FOR TOWER 3 ALUM. WINDOW

DATE : 02-Aug-21 SCALE : 1:40
 DRAWN BY : IYVN CHECKED BY :
美特鋁質有限公司
 MIDT ALUMINIUM FABRICATOR LTD.
 Units 6-8, Sunray Industrial Centre, 1/F
 610 Chee Kwo Ling Road, Kwai Tsing
 Tel:23489211-4 Fax:(852)2727666
 DWG NO. : JB56-SD-PW-5304 REV : 1

REQUIRED		PROVIDED	
LOCATION	OPENABLE AREA	GLAZING AREA	GLAZING AREA
A5-BR2	0.263	0.420	0.548
B1-BR1	0.263	0.420	0.985
B3-BR1	0.263	0.420	
B6-BR1	0.263	0.420	

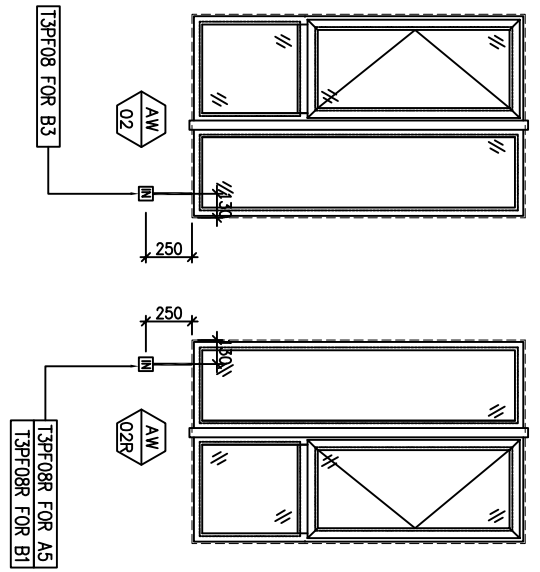
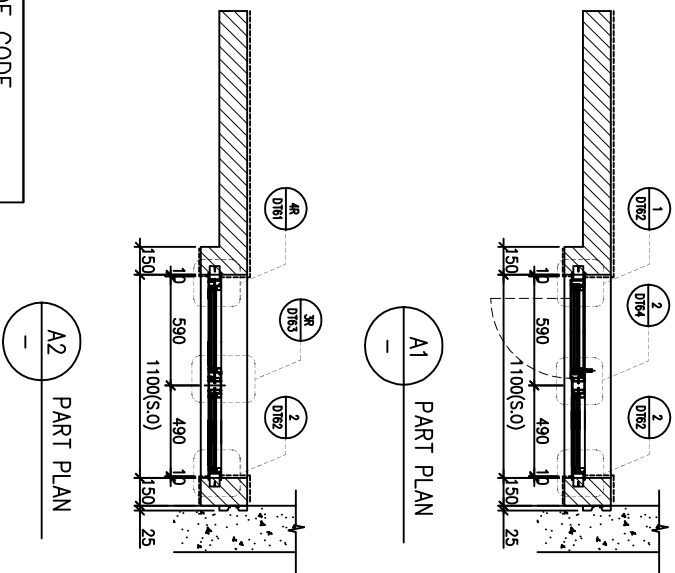
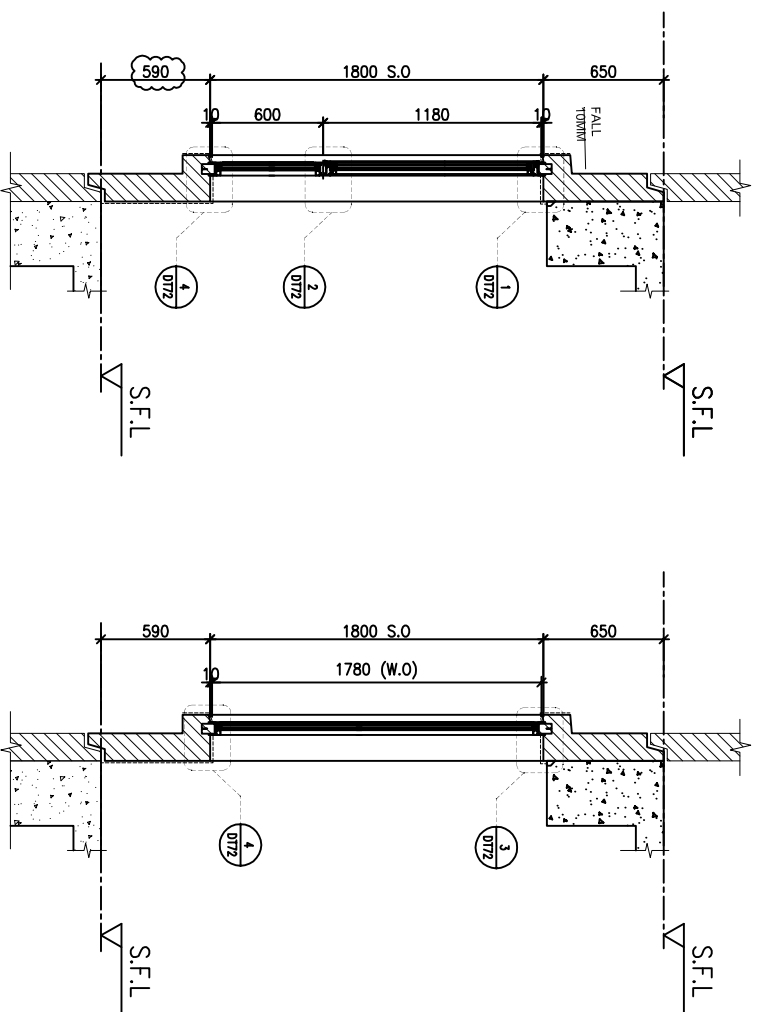
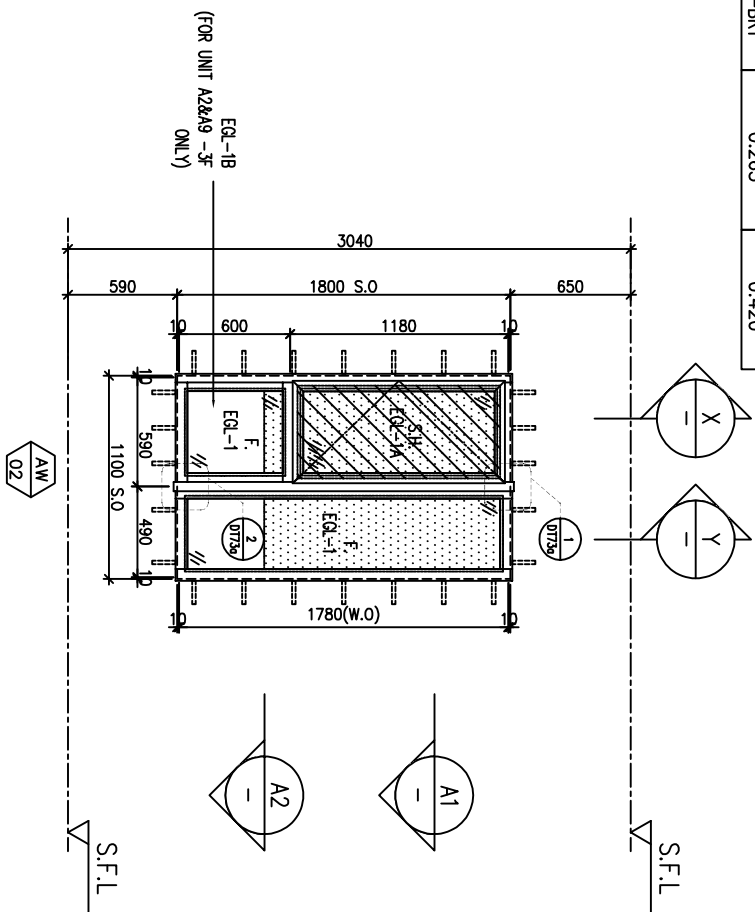

FACADE CODE		
LWK	鴻輝	UNIT
PF-08	T3PF-25	B10
PF-08R	T3PF-10	A6
PF-08R	T3PF-20	B1

WINDOW MARK	AW02	AW02R
LOCATION	3/F-42/F(4/F,13/F,14/F,24/F,34/F OMITTED) UNIT {B10}	3/F-42/F(4/F,13/F,14/F,24/F,34/F OMITTED) UNIT {A6}, B1
SECTION	70mm ALUM. SECTION	70mm ALUM. SECTION
GLAZING	EGL-1,EGL-1A	EGL-1,EGL-1A
QUANTITY	35 Nos	35 Nos / 35 Nos
REMARKS	FACADE(TYPE T3PF08 FOR 3/F~42/F) ,4 BAR HINGE-LIP HING (HHMS-N16)	FACADE(TYPE T3PF08R FOR 3/F~42/F) ,4 BAR HINGE-LIP HING (HHMS-N16)

BD. REF :

CLIENT :
SUN HUNG KAI
 REAL ESTATE AGENCY LTD.
 42/F SUN HUNG KAI CENTRE, WANCHAI, HONGKONG

ARCHITECT :
lwk&partners
 a r c h i t e c t s

MAIN CONTRACTOR :
怡輝建築有限公司
Yee Fai Building Contractors Ltd.

STRUCTURAL ENGINEER :
ARUP
 ALPHA CONSULTING LIMITED
 Steel Structure & Facade Specialist

NOTE :
 1. ALL DIMENSIONS ARE IN mm.
 2. ALL ELEVATIONS ARE VIEWED FROM OUTSIDE.
 3. ALL DIMENSIONS TO BE VERIFIED ON SITE BEFORE FABRICATION.

LEGEND :
 (X1) --- DETAIL MARK NO.
 (X001) --- REEFER SHEET NO.
 1. F.F.L. --- FINISHED FLOOR LEVEL
 2. S.F.L. --- STRUCTURAL FLOOR LEVEL
 3. (R) --- REVERSED DETAIL

4. GLASS LEGEND
 EQ1-1---8mmHS+12mm AIR GAP+10mmTP THK. I.G.U.
 EQ1-2---10mm THK. CLEAR TEMPERED GLASS
 EQ1-4---10mm THK. TEMPERED ACID ETCHED GLASS
 EQ1-1A---8mmHS+12mm AIR GAP+8mmTP THK. I.G.U.
 EQ1-1B---8mmHS+12mm AIR GAP+10mmTP THK. I.G.U.

NO.	DATE	REVISION	REVISION SUBJECT TO ARCH/COMMENT	BY
K	26/10/2022	REVISION SUBJECT TO GRP PLAN		h
J	21/09/2022	REVISION SUBJECT TO ARCH/COMMENT		h
I	17/08/2022	REVISION SUBJECT TO ARCH/COMMENT		h
H	22/04/2022	REVISION SUBJECT TO ARCH/COMMENT		h
G	09/04/2022	REVISION SUBJECT TO ARCH/COMMENT		h
F	14/12/2021	REVISION SUBJECT TO ARCH/COMMENT		h
E	29/11/2021	REVISION SUBJECT TO ARCH/COMMENT		h

JOB NO. : J-856
 PROJECT : PROPOSED DEVELOPMENT ABOVE LIGHT RAIL TIN WING STOP,TSWTL NO.23,AREA 33,TIN SHUI WAI, N.T.
 TITLE : WINDOW SCHEDULE FOR TOWER 3 ALUM. WINDOW

DATE : 02-Aug-21 SCALE : 1:40
 DRAWN BY : IYVN CHECKED BY :
美特鋁質有限公司
 MIDT ALUMINIUM FABRICATOR LTD.
 Units 6-8, Sunray Industrial Centre, 1/F
 610 Chee Kwo Ling Road, Kwai Tsoum
 Tel:23489211-4 Fax:(852)2727666
 DWG NO. : 0856-SD-PW-5305 REV : K

REQUIRED		PROVIDED	
LOCATION	OPENABLE AREA	GLAZING AREA	GLAZING AREA
A2-MBR	0.460	0.736	0.548
A5-MBR	0.473	0.757	1.495
A9-MBR	0.471	0.754	
A15-MBR	0.435	0.696	
B6-MBR	0.435	0.696	
B7-MBR	0.435	0.696	

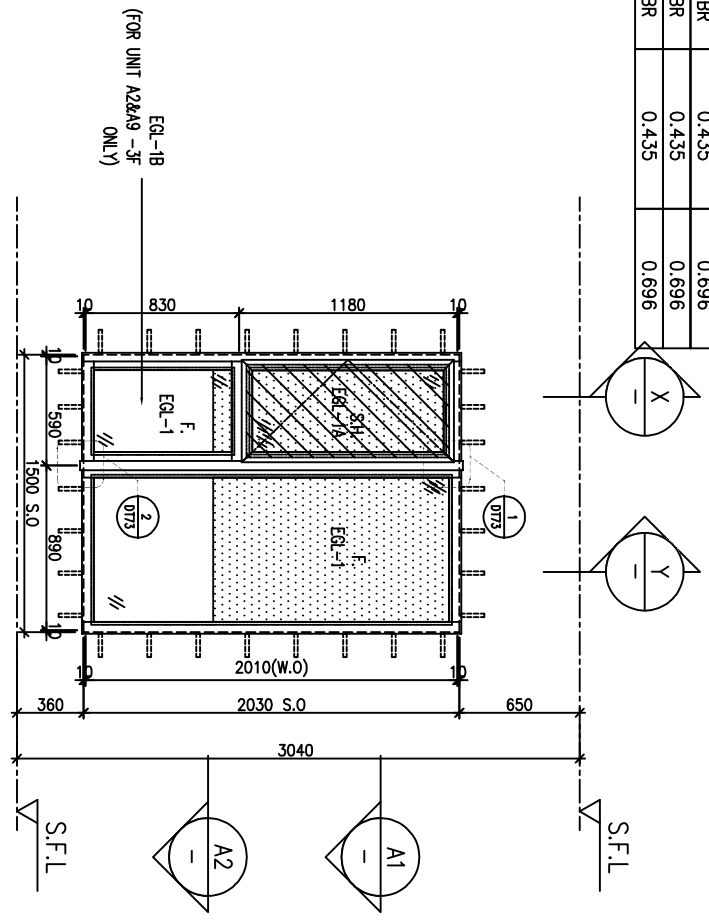

ELEVATION

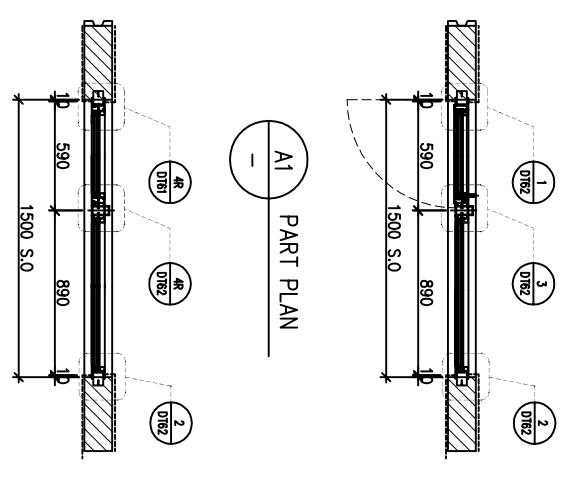
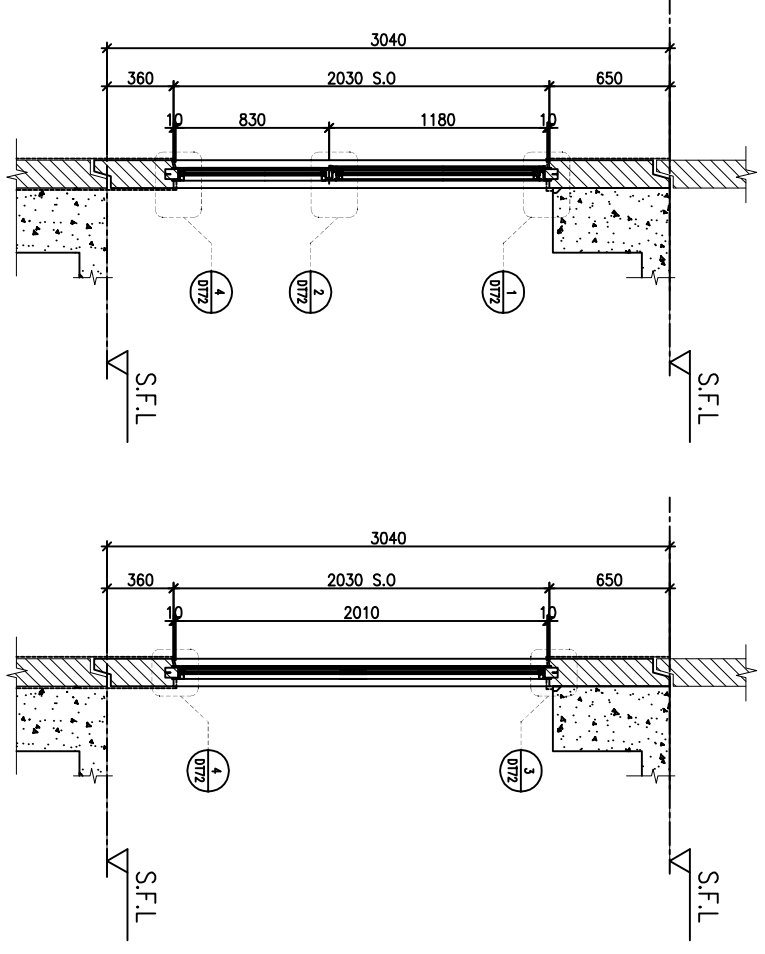

FACADE CODE		UNIT	
LWK	鴻輝	A3	
PF-10	T3PF-06	A6	
PF-10	T3PF-11	A10	
PF-10	T3PF-38	B7	

WINDOW MARK

LOCATION	SECTION	QUANTITY	REMARKS
3/F-42/F(4/F,13/F,14/F,24/F,34/F OMITTED) UNIT {A3, A6, A10}, B7	70mm ALUM. SECTION	35 Nos / 35 Nos / 35 Nos	FACADE(TYPE T3PF10 FOR 3/F~42/F), 4 BAR HINGE-LIP HING (HHMS-N16)

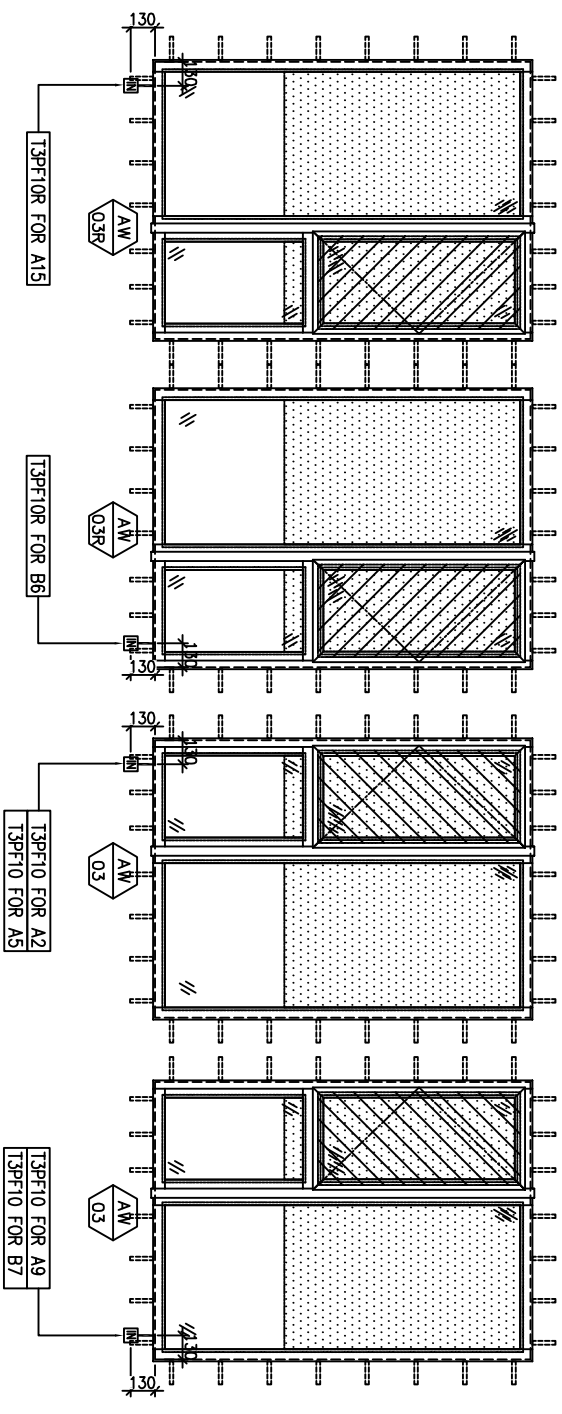

BD. REF :

CLIENT : **SUN HUNG KAI**
REAL ESTATE AGENCY LTD.
42/F SUN HUNG KAI CENTRE, WANCHAI, HONGKONG

ARCHITECT : **lwk&partners**
ARCHITECTS

MAIN CONTRACTOR : **怡輝建築有限公司**
Yee Fai Building Contractors Ltd.

STRUCTURAL ENGINEER : **ARUP**
ALPHA CONSULTING LIMITED
Steel Structure & Façade Specialist

FACADE CONSULTANT :

NOTE :

- ALL DIMENSIONS ARE IN mm.
- ALL ELEVATIONS ARE VIEWED FROM OUTSIDE.
- ALL DIMENSIONS TO BE VERIFIED ON SITE BEFORE FABRICATION.

LEGEND :

- X1 --- DETAIL MARK NO.
- X2001 --- REEFER SHEET NO.
- 1. F.F.L. --- FINISHED FLOOR LEVEL
- 2. S.F.L. --- STRUCTURAL FLOOR LEVEL
- 3. (R) --- REVERSED DETAIL

4. GLASS LEGEND

- EQ-1 --- 6mmHS+12mm AIR GAP+10mmTP THK. I.G.U.
- EQ-2 --- 10mm THK. CLEAR TEMPERED GLASS
- EQ-4 --- 10mm THK. TEMPERED ACID ETCHED GLASS
- EQ-1A --- 6mmHS+12mm AIR GAP+8mmTP THK. I.G.U.
- EQ-1B --- 6mmHS+12mm AIR GAP+10mmTP ACID-ETCHED THK. I.G.U.

JOB NO. : J-856

PROJECT : PROPOSED DEVELOPMENT ABOVE LIGHT RAIL TIN WING STOP-TSWTL NO.23,AREA 33,TIN SHUI WAI, N.T.

TITLE : WINDOW SCHEDULE FOR TOWER 3 ALUM. WINDOW

DATE : 02-Aug-21 SCALE : 1:40

DRAWN BY : IYVN CHECKED BY :

UNITED BUILDING RESEARCHERS LTD.
Units 6-8, Sunray Industrial Centre, 1/F
610 Cheong Kwo Ling Road, Kowloon
Tel:23489211-4 Fax:(852)27272666

DWG NO. : 1856-SD-PW-5306 REV. : K

B.D. REF :

CLIENT :

SUN HUNG KAI
REAL ESTATE AGENCY LTD.
42/F SUN HUNG KAI CENTRE, WANCHAI, HONGKONG

ARCHITECT :

lwk&partners
A R C H I T E C T S

MAIN CONTRACTOR :

怡輝建築有限公司
Yee Fai Building Contractors Ltd.

STRUCTURAL ENGINEER :

ARUP
ALPHA CONSULTING LIMITED
Steel Structure & Façade Specialist

FAÇADE CONSULTANT :

α ALPHA CONSULTING LIMITED
Steel Structure & Façade Specialist

ELEVATION

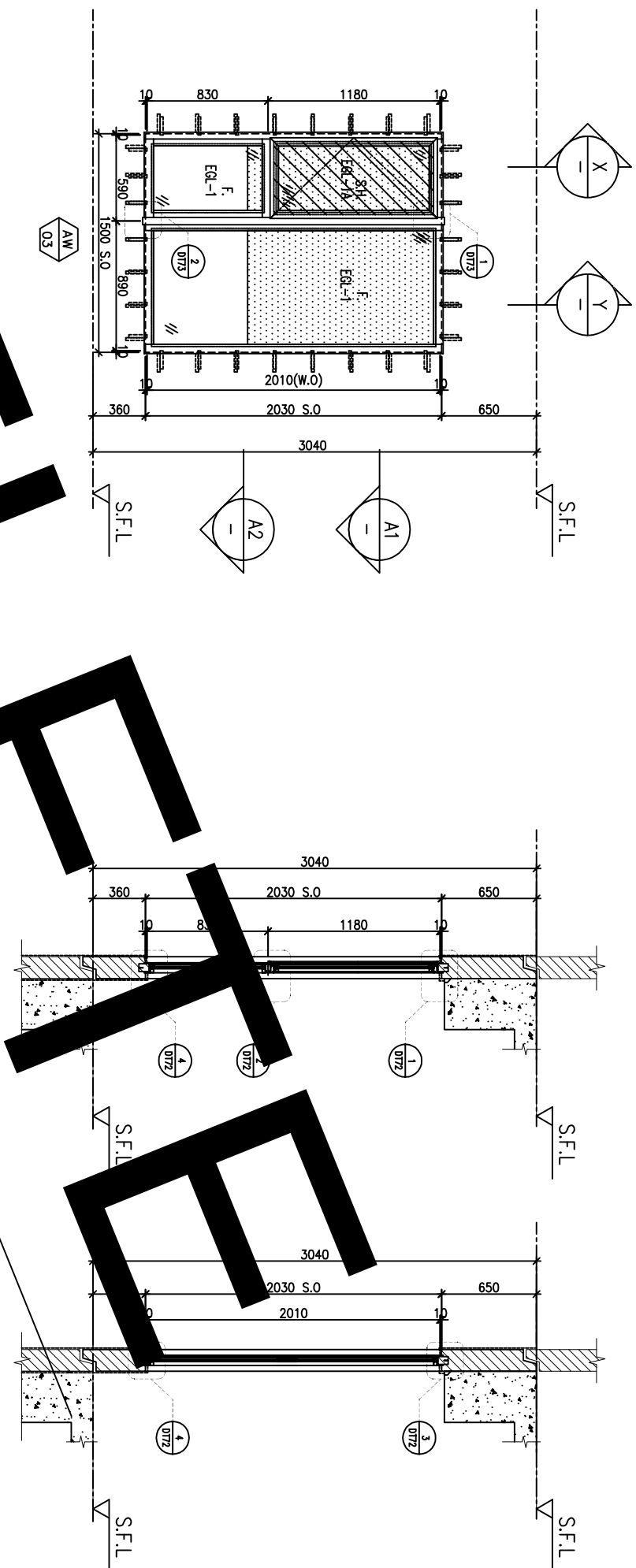

DEFERRED

T PLAN

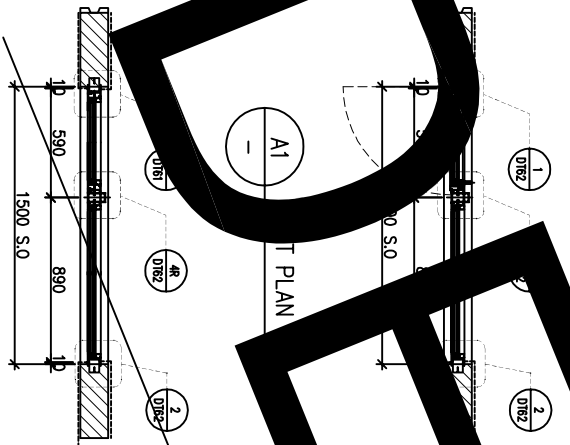

PART PLAN

FAÇADE CODE

LWK	鴻輝	UNIT
PF-11	±3PF-03	A1
PF-11	±3PF-17	B10

CHANGE TO IN-SITU WINDOWS?
CHANGE TO IN-SITU WINDOWS?

WINDOW MARK
AW
03

LOCATION 3/F-42/F(4/F,13/F,14/F,24/F,34/F OMITTED) UNIT A1, B10

SECTION 70mm ALUM. SECTION

GLAZING EGL-1,EGL-1A

QUANTITY 35 Nos / 35 Nos

REMARKS FAÇADE(TYPE T3PF11 FOR 3/F-42/F)

NOTE :

1. ALL DIMENSIONS ARE IN mm.
2. ALL ELEVATIONS ARE VIEWED FROM OUTSIDE.
3. ALL DIMENSIONS TO BE VERIFIED ON SITE BEFORE FABRICATION.

LEGEND :

X1 --- DETAIL MARK NO.
X2001 --- REEFER SHEET NO.

1. F.F.L. --- FINISHED FLOOR LEVEL
2. S.F.L. --- STRUCTURAL FLOOR LEVEL
3. (R) --- REVERSED DETAIL

4. GLASS LEGEND

EGL-1	---8mmHS+12mm AIR GAP+10mmTP THK. I.G.U.
EGL-2	---10mm THK. CLEAR TEMPERED GLASS
EGL-4	---10mm THK. TEMPERED ACID ETCHED GLASS
EGL-1A	---8mmHS+12mm AIR GAP+8mmTP THK. I.G.U.
EGL-1B	---8mmHS+12mm AIR GAP+10mmTP THK. I.G.U.
H	---10mmTP THK. I.G.U.
A	---10mmTP THK. I.G.U.
G	REVISION SUBJECT TO ARCH.COMMENT
F	REVISION SUBJECT TO ARCH.COMMENT
E	REVISION SUBJECT TO ARCH.COMMENT
D	REVISION SUBJECT TO ARCH.COMMENT
C	REVISION SUBJECT TO ARCH.COMMENT
B	REVISION SUBJECT TO ARCH.COMMENT
A	REVISION SUBJECT TO ARCH.COMMENT
DATE	REVISION

JOB NO. : J-856

PROJECT : PROPOSED DEVELOPMENT ABOVE LIGHT RAIL TIN WING STOP,T3WTL NO.23,AREA 33,TIN SHUI WAI, N.T.

TITLE : WINDOW SCHEDULE FOR TOWER 3 ALUM. WINDOW

DATE : 02-Aug-21 SCALE : 1:40

DRAWN BY : IYVN CHECKED BY :

美特鋁質有限公司
MIDI ALUMINIUM FABRICATOR LTD.
Units 6-8, Sunray Industrial Centre,
610 Chee Kwo Ling Road, Kowloon
Tel:23489211-4 Fax:(852)2727666

DWG NO. : JB56-SD-PW-5307 REV. : H

LOCATION	OPENABLE AREA	GLAZING AREA	OPENABLE AREA	GLAZING AREA
A7-MBR	0.388	0.620	0.548	1.495

LOCATION	OPENABLE AREA	GLAZING AREA	OPENABLE AREA	GLAZING AREA
A7-STO	N/A	N/A	N/A	N/A

LOCATION	OPENABLE AREA	GLAZING AREA	OPENABLE AREA	GLAZING AREA
A7-STO	N/A	N/A	N/A	N/A

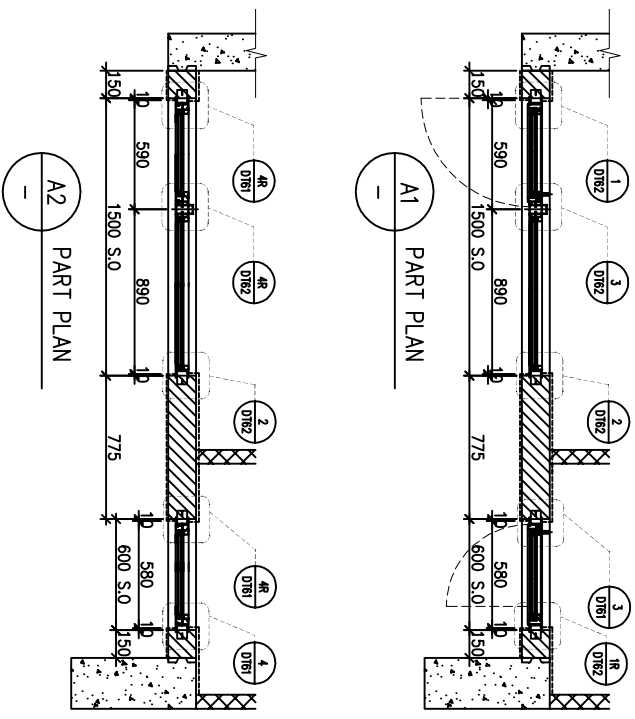
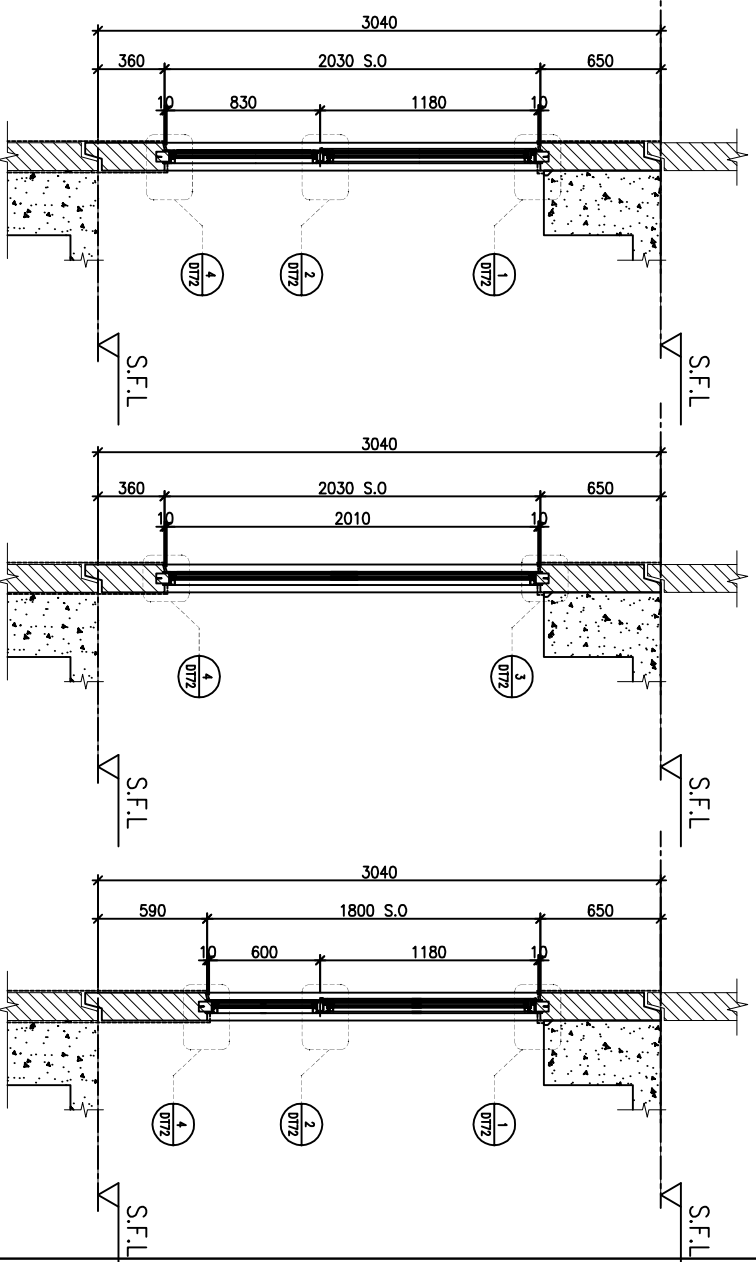
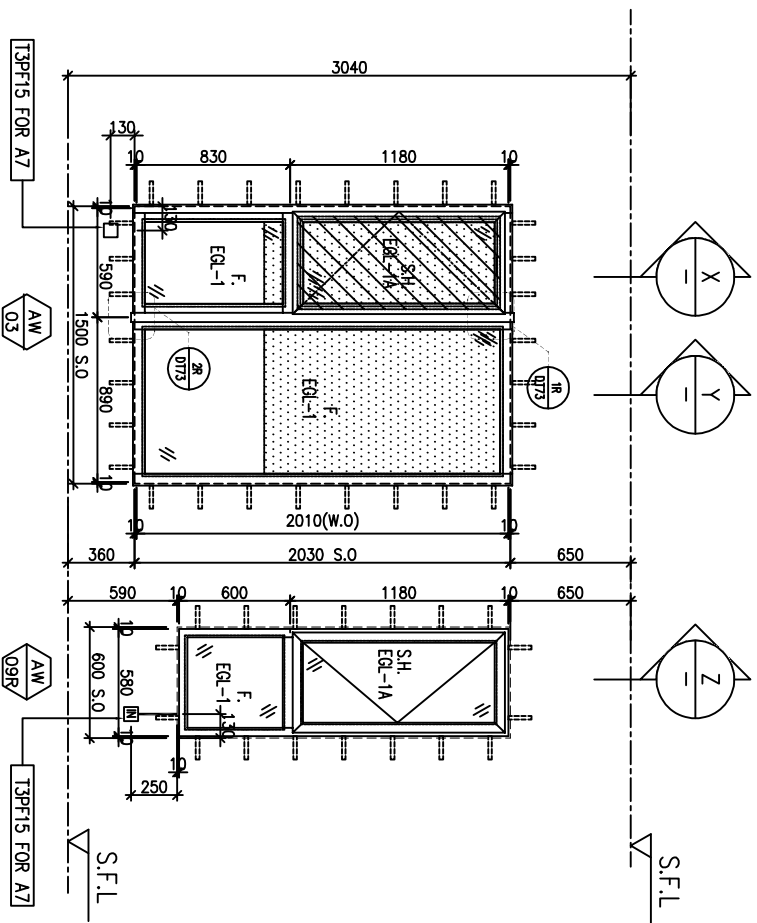

FACADE CODE		
LWK	鴻輝	UNIT
PF-15	T3PF-14	A8

WINDOW MARK	AW 03	AW 09R
LOCATION	3/F-42/F(4/F,13/F,14/F,24/F,34/F OMITTED) UNIT A8	
SECTION	70mm ALUM. SECTION	
GLAZING	EGL-1, EGL-1A	
QUANTITY	35 Nos	
REMARKS	FACADE(TYPE T3PF15 FOR 3/F-42/F), 4 BAR HINGE-LIP HING (HHMS-N16)	

BD. REF :

CLIENT :

SUN HUNG KAI
REAL ESTATE AGENCY LTD.
42/F SUN HUNG KAI CENTRE, WANCHAI, HONGKONG

ARCHITECT :

lwk&partners
ARCHITECTS

MAIN CONTRACTOR :

Yee Fai 怡輝建築有限公司
Building Contractors Ltd.

STRUCTURAL ENGINEER :

ARUP
ALPHA CONSULTING LIMITED
Steel Structure & Façade Specialist

FACADE CONSULTANT :

ARUP
ALPHA CONSULTING LIMITED
Steel Structure & Façade Specialist

- NOTE :
1. ALL DIMENSIONS ARE IN mm.
 2. ALL ELEVATIONS ARE VIEWED FROM OUTSIDE.
 3. ALL DIMENSIONS TO BE VERIFIED ON SITE BEFORE FABRICATION.

LEGEND :

- ①1 --- DETAIL MARK NO.
 - ①2001 --- REEFER SHEET NO.
 - 1. F.F.L. --- FINISHED FLOOR LEVEL
 - 2. S.F.L. --- STRUCTURAL FLOOR LEVEL
 - 3. (R) --- REVERSED DETAIL
4. GLASS LEGEND

- EGL-1 --- 8mmHS+12mm AIR GAP+10mmTP THK. I.G.U.
- EGL-2 --- 10mm THK. CLEAR TEMPERED GLASS
- EGL-4 --- 10mm THK. TEMPERED ACID ETCHED GLASS
- EGL-1A --- 8mmHS+12mm AIR GAP+8mmTP THK. I.G.U.
- EGL-1B --- 8mmHS+12mm AIR GAP+10mmTP ACID-ETCHED THK. I.G.U.

NO.	DATE	REVISION	SUBJECT TO ARCH/COMMENT	BY
L	26/10/2022	REVISION SUBJECT TO GRP PLAN		h
K	21/09/2022	REVISION SUBJECT TO ARCH/COMMENT		h
J	17/08/2022	REVISION SUBJECT TO ARCH/COMMENT		h
I	17/05/2022	REVISION SUBJECT TO ARCH/COMMENT		h
H	22/04/2022	REVISION SUBJECT TO ARCH/COMMENT		h
G	09/04/2022	REVISION SUBJECT TO ARCH/COMMENT		h
F	14/12/2021	REVISION SUBJECT TO ARCH/COMMENT		h

JOB NO. : J-856

PROJECT :

PROPOSED DEVELOPMENT ABOVE LIGHT RAIL TIN WING STOP TSWTL NO.23, AREA 33, TIN SHUI WAI, N.T.

TITLE :

WINDOW SCHEDULE FOR TOWER 3 ALUM. WINDOW

DATE : 02-Aug-21 SCALE : 1:40

DRAWN BY : IYVN

CHECKED BY :

美特铝质有限公司
MIDI ALUMINIUM FABRICATOR LTD.
Units 6-8, Sunray Industrial Centre, 1/F
610 Chee Kwo Ling Road, Kwai Tsing, N.T.
Tel: 23489211-4 Fax: (852) 2727666

DWG NO. : JB56-SD-PW-5308 REV. : L

REQUIRE		PROVIDED		REQUIRE		PROVIDED	
LOCATION	OPENABLE AREA	GLAZING AREA	OPENABLE AREA	GLAZING AREA	LOCATION	OPENABLE AREA	GLAZING AREA
A5-BR1	0.263	0.420	0.548	0.985	A3-BR1	0.263	0.420
A13-BR1	0.263	0.420			A12-BR1	0.263	0.420

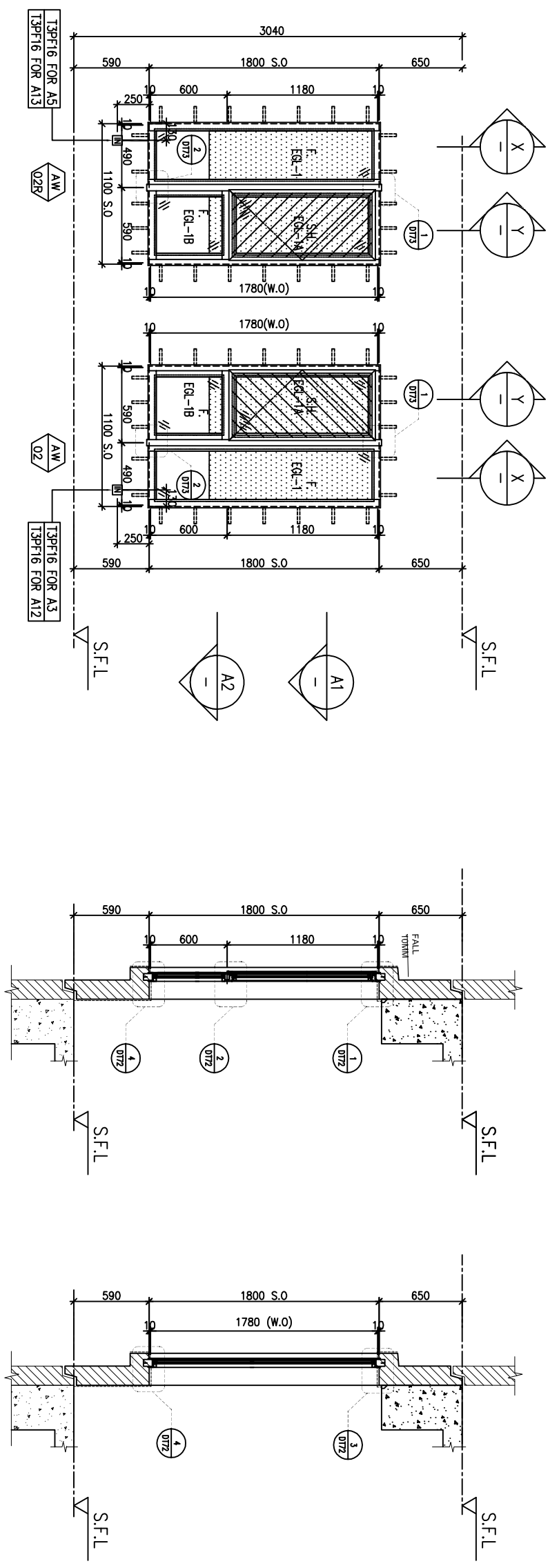

ELEVATION

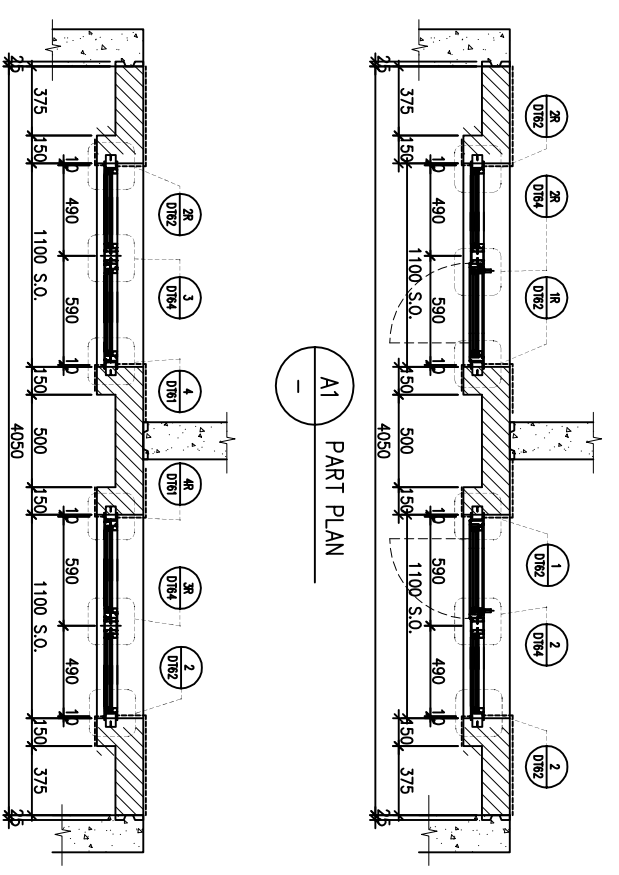

FACADE CODE		UNIT
LWK	鴻輝	A5
PF-16	T3PF-09	A6
PF-16	T3PF-43	A15
PF-16	T3PF-43	A13

A2 PART PLAN

A1 PART PLAN

X PART SECTION

Y PART SECTION

WINDOW MARK	AW 02	AW 02B
LOCATION	3/F UNIT A6&A5, A15&A13	
SECTION	70mm ALUM. SECTION	
GLAZING	EGL-1, EGL-1A	
QUANTITY	1 No	1 No
REMARKS	FACADE(TYPE T3PF16 FOR 3/F) 4 BAR HINGE-LIP HING (HHMS-N16)	

BD. REF :

CLIENT :
SUN HUNG KAI
 REAL ESTATE AGENCY LTD.
 42/F SUN HUNG KAI CENTRE, WANCHAI, HONGKONG

ARCHITECT :
lwk&partners
 A R C H I T E C T S

MAIN CONTRACTOR :
怡輝建築有限公司
 Yee Fai Building Contractors Ltd.

STRUCTURAL ENGINEER :
ARUP
 ALPHA CONSULTING LIMITED
 Steel Structure & Façade Specialist

FACADE CONSULTANT:

NOTE:
 1. ALL DIMENSIONS ARE IN mm.
 2. ALL ELEVATIONS ARE VIEWED FROM OUTSIDE.
 3. ALL DIMENSIONS TO BE VERIFIED ON SITE BEFORE FABRICATION.

LEGEND:
 X1 --- DETAIL MARK NO.
 X2001 --- REEFER SHEET NO.
 1. F.F.L. --- FINISHED FLOOR LEVEL
 2. S.F.L. --- STRUCTURAL FLOOR LEVEL
 3. (R) --- REVERSED DETAIL

4. GLASS LEGEND
 EGL-1 --- 8mmHS+12mm AIR GAP+10mmTP THK. I.G.U.
 EGL-2 --- 10mm THK. CLEAR TEMPERED GLASS
 EGL-4 --- 10mm THK. TEMPERED ACID ETCHED GLASS
 EGL-1A --- 8mmHS+12mm AIR GAP+8mmTP THK. I.G.U.
 EGL-1B --- 8mmHS+12mm AIR GAP+10mmTP THK. I.G.U.
 10mmTP ACID-ETCHED THK. I.G.U.

NO.	DATE	REVISION	BY
D	26/10/2022	REVISION SUBJECT TO GEP PLAN	YH
C	21/09/2022	REVISION SUBJECT TO ARCH.COMMENT	HW
B	17/09/2022	REVISION SUBJECT TO ARCH.COMMENT	HW
A	27/06/2022	REVISION SUBJECT TO ARCH.COMMENT	HW

JOB NO. : J-856
 PROJECT : PROPOSED DEVELOPMENT ABOVE LIGHT RAIL TIN WING STOP TSWTL NO.23, AREA 33, TIN SHUI WAI, N.T.
 TITLE : WINDOW SCHEDULE FOR TOWER 3 ALUM. WINDOW

DATE : 23-Apr-21
 SCALE : 1:40
 DRAWN BY : IYVN
 CHECKED BY :

UNITED STATES OF AMERICA
美特鋁質有限公司
 MIDT ALUMINUM FABRICATOR LTD.
 Units 6-8, Sunray Industrial Centre, 1/F
 610 Chee Kwo Ling Road, Kowloon
 Tel: 23489211-4 Fax: (852) 27272666
 DWG NO. : JB56-SD-PW-5309d REV : D

REQUIRE		PROVIDED		REQUIRE		PROVIDED	
LOCATION	OPENABLE AREA	GLAZING AREA	OPENABLE AREA	GLAZING AREA	LOCATION	OPENABLE AREA	GLAZING AREA
A5-BR1	0.263	0.420	0.548	0.985	A3-BR1	0.263	0.420
A13-BR1	0.263	0.420			A12-BR1	0.263	0.420

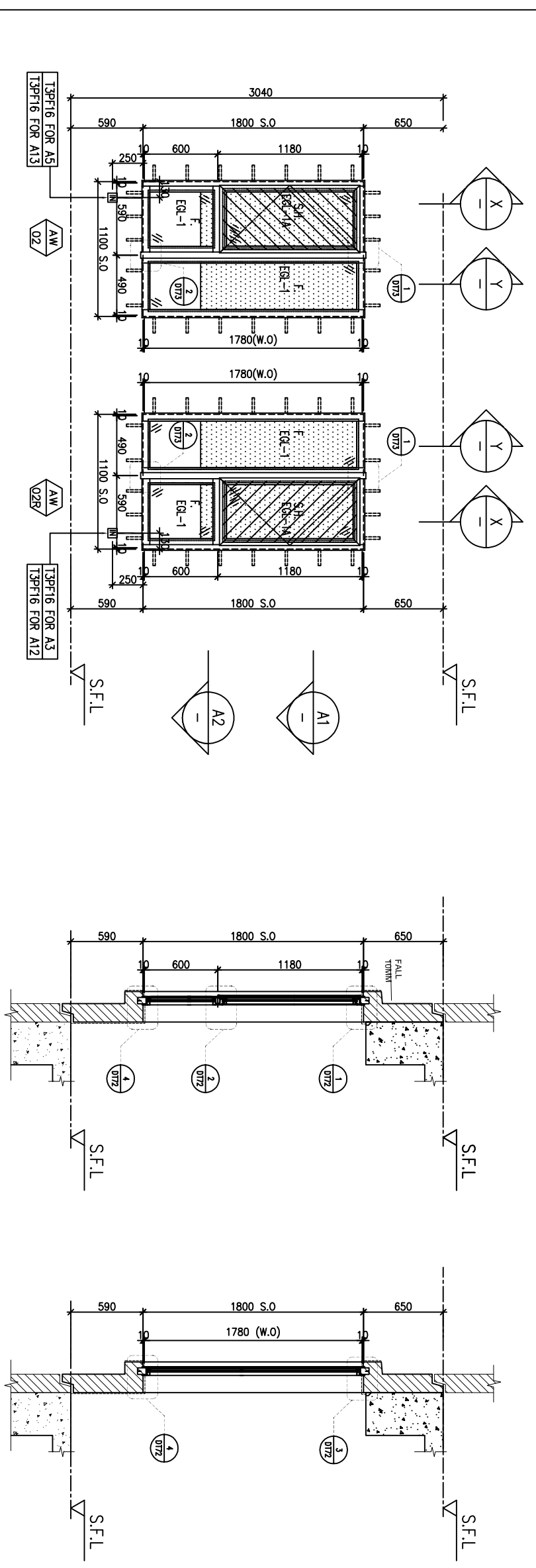

ELEVATION

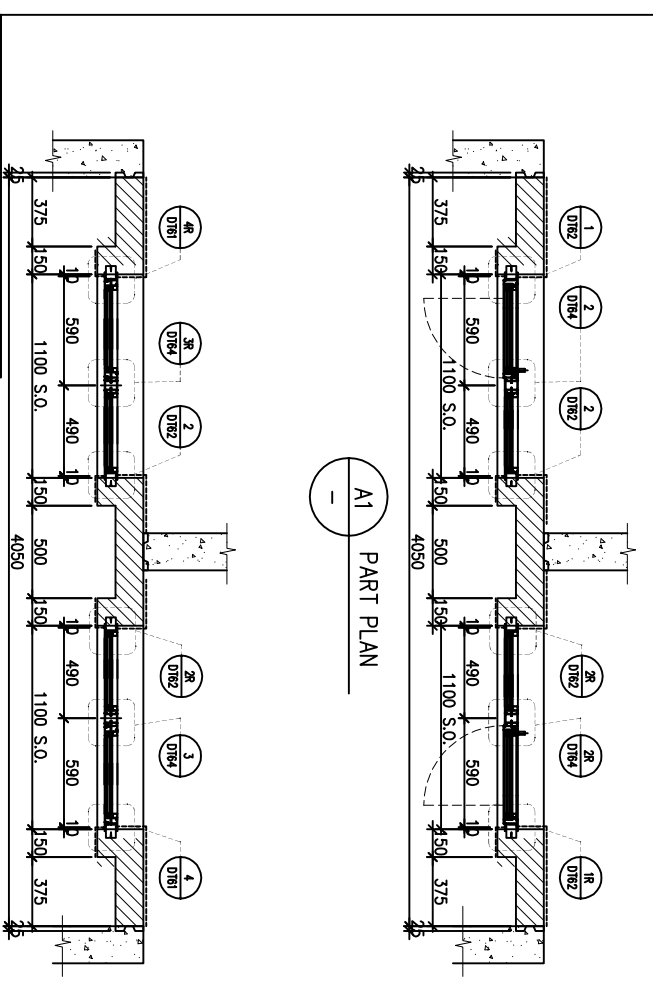

FAÇADE CODE

LWK	UNIT
PF-16	T3PF-09
PF-16	T3PF-09
PF-16	T3PF-43
PF-16	T3PF-43

A2 PART PLAN

A1 PART PLAN

WINDOW MARK	AW 02	AW 02R
LOCATION	5/F-42/F(4/F,13/F,14/F,24/F,34/F OMITTED) UNIT A6&A5, A15&A13	
SECTION	70mm ALUM. SECTION	
GLAZING	EGL-1, EGL-1A	
QUANTITY	34 Nos	34 Nos
REMARKS	FAÇADE(TYPE T3PF16 FOR 5/F-42/F), 4 BAR HINGE-LIP HING (HHMS-N16)	

BD. REF :

CLIENT :
SUN HUNG KAI
 REAL ESTATE AGENCY LTD.
 42/F SUN HUNG KAI CENTRE, WANCHAI, HONGKONG

ARCHITECT :
lwk&partners
 a r c h i t e c t s

MAIN CONTRACTOR :
 怡輝建築有限公司
Yee Fai
 Building Contractors Ltd.

STRUCTURAL ENGINEER :
ARUP
 ALPHA CONSULTING LIMITED
 Steel Structure & Façade Specialist

FAÇADE CONSULTANT:
ARUP
 ALPHA CONSULTING LIMITED
 Steel Structure & Façade Specialist

NOTE:

- ALL DIMENSIONS ARE IN mm.
- ALL ELEVATIONS ARE VIEWED FROM OUTSIDE.
- ALL DIMENSIONS TO BE VERIFIED ON SITE BEFORE FABRICATION.

LEGEND:

- (X1) --- DETAIL MARK NO.
- (X001) --- REEFER SHEET NO.
- 1. F.F.L. --- FINISHED FLOOR LEVEL
- 2. S.F.L. --- STRUCTURAL FLOOR LEVEL
- 3. (R) --- REVERSED DETAIL

4. GLASS LEGEND

- EGL-1 --- 8mmHS+12mm AIR GAP+10mmTP THK. IGLU.
- EGL-2 --- 10mm THK. CLEAR TEMPERED GLASS
- EGL-4 --- 10mm THK. TEMPERED ACID ETCHED GLASS
- EGL-1A --- 8mmHS+12mm AIR GAP+8mmTP THK. IGLU.
- EGL-1B --- 8mmHS+12mm AIR GAP+10mmTP ACID-ETCHED THK. IGLU.

NO.	DATE	REVISION	BY
K	26/10/2022	REVISION SUBJECT TO GRP PLAN	h
J	17/08/2022	REVISION SUBJECT TO ARCH/COMMENT	h
I	17/08/2022	REVISION SUBJECT TO ARCH/COMMENT	h
H	22/04/2022	REVISION SUBJECT TO ARCH/COMMENT	h
G	09/04/2022	REVISION SUBJECT TO ARCH/COMMENT	h
F	14/12/2021	REVISION SUBJECT TO ARCH/COMMENT	h
E	29/11/2021	REVISION SUBJECT TO ARCH/COMMENT	h

JOB NO. : J-856

PROJECT : PROPOSED DEVELOPMENT ABOVE LIGHT RAIL TIN WING STOP/TSWTL NO.23,AREA 33,TIN SHUI WAI, N.T.

TITLE : WINDOW SCHEDULE FOR TOWER 3 ALUM. WINDOW

DATE : 02-Aug-21 SCALE : 1:40

DRAWN BY : Ivan

CHECKED BY :

美特鋁質有限公司
 MIDT ALUMINUM FABRICATOR LTD.
 Units 6-8, Sunray Industrial Centre, 1/F
 610 Chee Kwo Ling Road, Kwai Tsoum
 Tel:23489211-4 Fax:(852)2727666
 DWG NO. : JB56-SD-PW-5309 REV : K

B.D. REF :

CLIENT :

SUN HUNG KAI
REAL ESTATE AGENCY LTD.
42/F SUN HUNG KAI CENTRE, WANCHAI, HONGKONG

ARCHITECT :

lwk&partners
a r c h i t e c t s

MAIN CONTRACTOR :

怡輝建築有限公司
Yee Fai
Building Contractors Ltd.

STRUCTURAL ENGINEER :

ARUP
ALPHA CONSULTING LIMITED
Steel Structure & Façade Specialist

FAÇADE CONSULTANT:

ARUP
ALPHA CONSULTING LIMITED
Steel Structure & Façade Specialist

NOTE:
1. ALL DIMENSIONS ARE IN mm.
2. ALL ELEVATIONS ARE VIEWED FROM OUTSIDE.
3. ALL DIMENSIONS TO BE VERIFIED ON SITE BEFORE FABRICATION.

LEGEND :

- (X1) --- DETAIL MARK NO.
- (X001) --- REFER SHEET NO.
- 1. F.F.L. --- FINISHED FLOOR LEVEL
- 2. S.F.L. --- STRUCTURAL FLOOR LEVEL
- 3. (R) --- REVERSED DETAIL
- 4. GLASS LEGEND

EG1-1	8mmHS+12mm AIR GAP+10mmTP THK. LGU.	18/10/2021	REVISION SUBJECT TO ARCH/COMMENT
EG1-2	10mm THK. CLEAR TEMPERED GLASS	18/10/2021	REVISION SUBJECT TO ARCH/COMMENT
EG1-4	10mm THK. TEMPERED ACID ETCHED GLASS	18/10/2021	REVISION SUBJECT TO ARCH/COMMENT
EG1-1A	8mmHS+12mm AIR GAP+8mmTP THK. LGU.	27/09/2021	REVISION SUBJECT TO ARCH/COMMENT
EG1-1B	8mmHS+12mm AIR GAP+10mmTP THK. LGU.	27/09/2021	REVISION SUBJECT TO ARCH/COMMENT
EG1-1C	8mmHS+12mm AIR GAP+10mmTP THK. LGU.	27/09/2021	REVISION SUBJECT TO ARCH/COMMENT
EG1-1D	8mmHS+12mm AIR GAP+10mmTP THK. LGU.	27/09/2021	REVISION SUBJECT TO ARCH/COMMENT
EG1-1E	8mmHS+12mm AIR GAP+10mmTP THK. LGU.	27/09/2021	REVISION SUBJECT TO ARCH/COMMENT
EG1-1F	8mmHS+12mm AIR GAP+10mmTP THK. LGU.	27/09/2021	REVISION SUBJECT TO ARCH/COMMENT
EG1-1G	8mmHS+12mm AIR GAP+10mmTP THK. LGU.	27/09/2021	REVISION SUBJECT TO ARCH/COMMENT
EG1-1H	8mmHS+12mm AIR GAP+10mmTP THK. LGU.	27/09/2021	REVISION SUBJECT TO ARCH/COMMENT
EG1-1I	8mmHS+12mm AIR GAP+10mmTP THK. LGU.	27/09/2021	REVISION SUBJECT TO ARCH/COMMENT
EG1-1J	8mmHS+12mm AIR GAP+10mmTP THK. LGU.	27/09/2021	REVISION SUBJECT TO ARCH/COMMENT
EG1-1K	8mmHS+12mm AIR GAP+10mmTP THK. LGU.	27/09/2021	REVISION SUBJECT TO ARCH/COMMENT
EG1-1L	8mmHS+12mm AIR GAP+10mmTP THK. LGU.	27/09/2021	REVISION SUBJECT TO ARCH/COMMENT
EG1-1M	8mmHS+12mm AIR GAP+10mmTP THK. LGU.	27/09/2021	REVISION SUBJECT TO ARCH/COMMENT
EG1-1N	8mmHS+12mm AIR GAP+10mmTP THK. LGU.	27/09/2021	REVISION SUBJECT TO ARCH/COMMENT
EG1-1O	8mmHS+12mm AIR GAP+10mmTP THK. LGU.	27/09/2021	REVISION SUBJECT TO ARCH/COMMENT
EG1-1P	8mmHS+12mm AIR GAP+10mmTP THK. LGU.	27/09/2021	REVISION SUBJECT TO ARCH/COMMENT
EG1-1Q	8mmHS+12mm AIR GAP+10mmTP THK. LGU.	27/09/2021	REVISION SUBJECT TO ARCH/COMMENT
EG1-1R	8mmHS+12mm AIR GAP+10mmTP THK. LGU.	27/09/2021	REVISION SUBJECT TO ARCH/COMMENT
EG1-1S	8mmHS+12mm AIR GAP+10mmTP THK. LGU.	27/09/2021	REVISION SUBJECT TO ARCH/COMMENT
EG1-1T	8mmHS+12mm AIR GAP+10mmTP THK. LGU.	27/09/2021	REVISION SUBJECT TO ARCH/COMMENT
EG1-1U	8mmHS+12mm AIR GAP+10mmTP THK. LGU.	27/09/2021	REVISION SUBJECT TO ARCH/COMMENT
EG1-1V	8mmHS+12mm AIR GAP+10mmTP THK. LGU.	27/09/2021	REVISION SUBJECT TO ARCH/COMMENT
EG1-1W	8mmHS+12mm AIR GAP+10mmTP THK. LGU.	27/09/2021	REVISION SUBJECT TO ARCH/COMMENT
EG1-1X	8mmHS+12mm AIR GAP+10mmTP THK. LGU.	27/09/2021	REVISION SUBJECT TO ARCH/COMMENT
EG1-1Y	8mmHS+12mm AIR GAP+10mmTP THK. LGU.	27/09/2021	REVISION SUBJECT TO ARCH/COMMENT
EG1-1Z	8mmHS+12mm AIR GAP+10mmTP THK. LGU.	27/09/2021	REVISION SUBJECT TO ARCH/COMMENT

JOB NO. : J-856

PROJECT : PROPOSED DEVELOPMENT ABOVE LIGHT RAIL TIN WING STOP TSWTL NO.23,AREA 33,TIN SHUI WAI, N.T.

TITLE : WINDOW SCHEDULE FOR TOWER 3 ALUM. WINDOW

DATE : 02-Aug-21 SCALE : 1:40

DRAWN BY : IYVN CHECKED BY :

美特鋁質有限公司
MIDI ALUMINUM FABRICATOR LTD.
Units 6-8, Sunray Industrial Centre, 1/F
610 Chee Kwo Ling Road, Kwai Tsan
Tel:23489211-4 Fax:(852)2727666
DWG NO. : J856-SD-PW-5310 REV. : 1

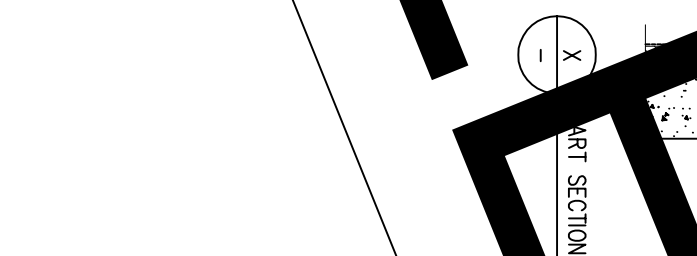
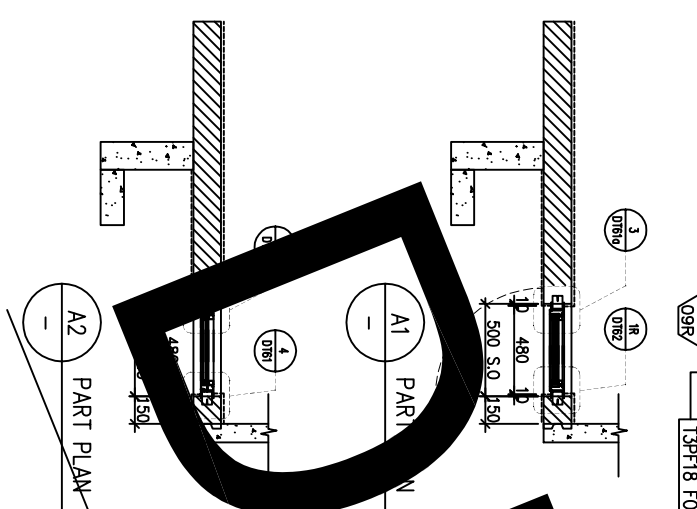
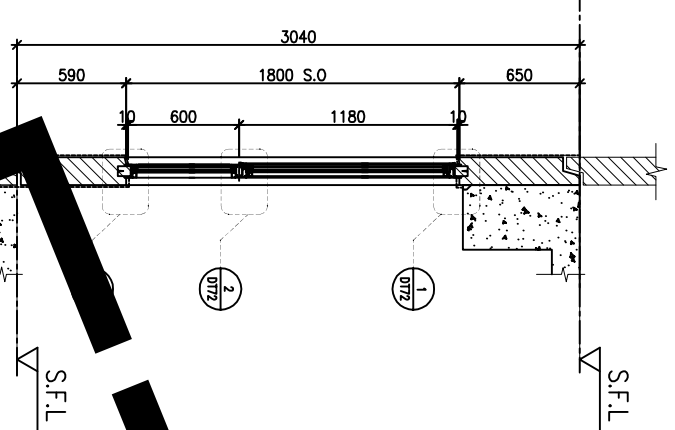
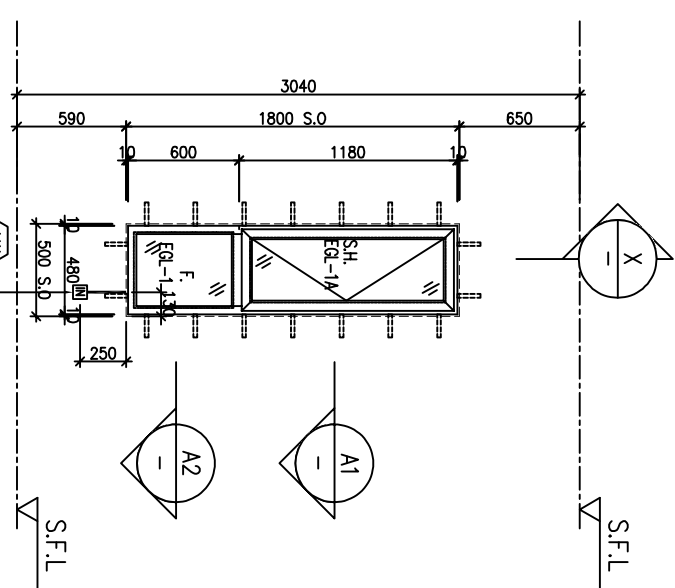

FAÇADE CODE	
LWK	鴻輝
PF-18	B2

CHANGE TO IN-SITU WINDOWS?

WINDOW MARK	AW 09R
LOCATION	3/F-42/F(4/F,13/F,14/F,24/F,34/F OMITTED) UNIT B2
SECTION	70mm ALUM. SECTION
GLAZING	EG1-1,EG1-1A
QUANTITY	35 Nos
REMARKS	FAÇADE(TYPE T3PF18 FOR 3/F-42/F)

DEFERRED

LOCATION	OPENABLE AREA	GLAZING AREA	OPENABLE AREA	GLAZING AREA
B6-BR1	0.263	0.420	0.548	0.985

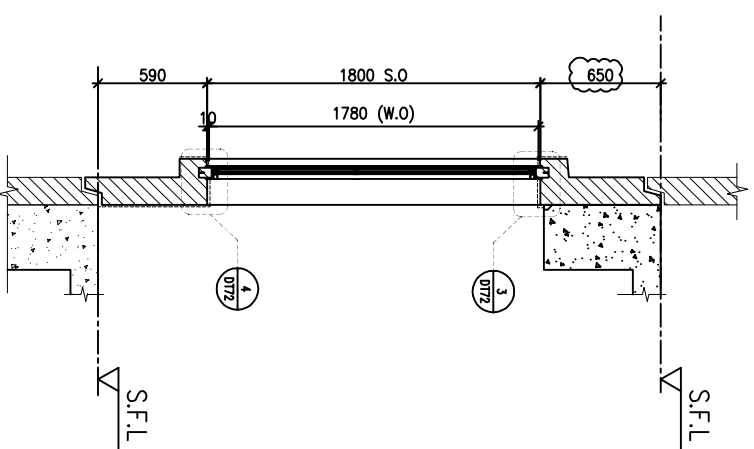
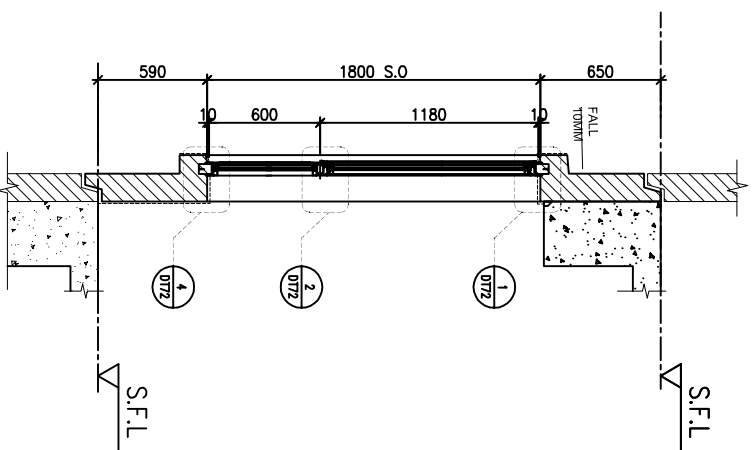
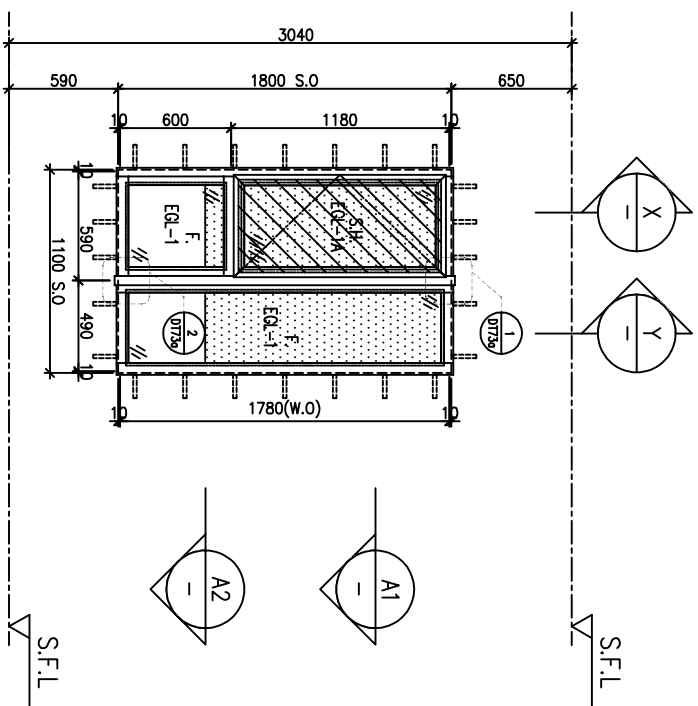

ELEVATION

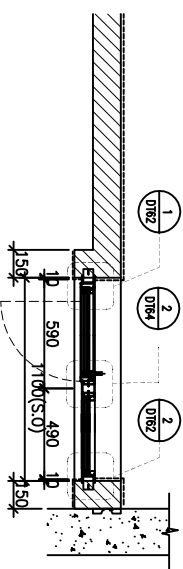

A1 PART PLAN

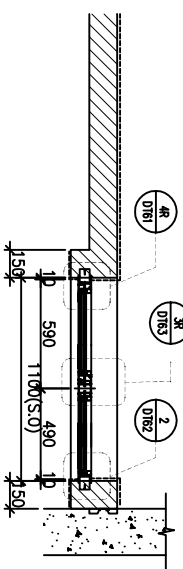

A2 PART PLAN

X PART SECTION

Y PART SECTION

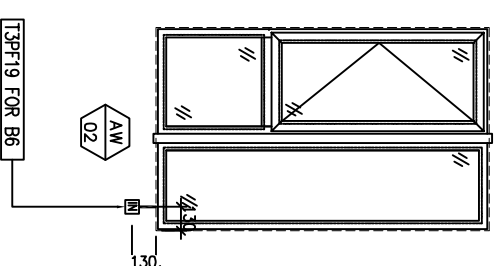

FAÇADE CODE

LWK 鴻輝 UNIT

PF-19 T3PF-28 B8

AW 02

WINDOW MARK	AW 02
LOCATION	3/F-42/F(4/F,13/F,14/F,24/F,34/F OMITTED) UNIT B8
SECTION	70mm ALUM. SECTION
GLAZING	EGL-1,EGL-1A
QUANTITY	35 Nos.
REMARKS	FAÇADE(TYPE T3PF19 FOR 3/F-42/F), 4 BAR HINGE-LIP HING (HHMS-N16)

BD. REF :

CLIENT :

SUN HUNG KAI
REAL ESTATE AGENCY LTD.
42/F SUN HUNG KAI CENTRE, WANCHAI, HONGKONG

ARCHITECT :

lwk&partners
ARCHITECTS

MAIN CONTRACTOR :

怡輝建築有限公司
Yee Fai Building Contractors Ltd.

STRUCTURAL ENGINEER :

ARUP
ALPHA CONSULTING LIMITED
Steel Structure & Façade Specialist

FAÇADE CONSULTANT :

ARUP
ALPHA CONSULTING LIMITED
Steel Structure & Façade Specialist

NOTE :

1. ALL DIMENSIONS ARE IN mm.
2. ALL ELEVATIONS ARE VIEWED FROM OUTSIDE.
3. ALL DIMENSIONS TO BE VERIFIED ON SITE BEFORE FABRICATION.

LEGEND :

- (X1) --- DETAIL MARK NO.
- (X001) --- REEFER SHEET NO.
- 1. F.F.L. --- FINISHED FLOOR LEVEL
- 2. S.F.L. --- STRUCTURAL FLOOR LEVEL
- 3. (R) --- REVERSED DETAIL

4. GLASS LEGEND

- EGL-1 --- 6mmHS+12mm AIR GAP+10mmTP THK. I.G.U.
- EGL-2 --- 10mm THK. CLEAR TEMPERED GLASS
- EGL-4 --- 10mm THK. TEMPERED ACID ETCHED GLASS
- EGL-1A --- 6mmHS+12mm AIR GAP+8mmTP THK. I.G.U.
- EGL-1B --- 8mmHS+12mm AIR GAP+10mmTP THK. I.G.U.

NO.	DATE	REVISION	REVISION SUBJECT TO ARCH/COMMENT	BY
H	28/10/2022	REVISION SUBJECT TO GEP PLAN		h1
G	21/09/2022	REVISION SUBJECT TO ARCH/COMMENT		h1
F	17/08/2022	REVISION SUBJECT TO ARCH/COMMENT		h1
E	22/04/2022	REVISION SUBJECT TO ARCH/COMMENT		h1
D	09/04/2022	REVISION SUBJECT TO ARCH/COMMENT		h1
C	14/12/2021	REVISION SUBJECT TO ARCH/COMMENT		h1
B	29/11/2021	REVISION SUBJECT TO ARCH/COMMENT		h1

JOB NO. : J-856

PROJECT : PROPOSED DEVELOPMENT ABOVE LIGHT RAIL TIN WING STOP,T3WTL NO.23,AREA 33,TIN SHUI WAI, N.T.

TITLE : WINDOW SCHEDULE FOR TOWER 3 ALUM. WINDOW

DATE : 02-Aug-21 SCALE : 1:40

DRAWN BY : Ivan CHECKED BY :

美特鋁質有限公司
MIDI ALUMINUM FABRICATOR LTD.
Units 6-8, Sunray Industrial Centre, 1/F
610 Chee Kwo Ling Road, Kwai Tsing
Tel:23489211-4 Fax:(852)2727666

DWG NO. : JB56-SD-PW-5311 REV. : H

REQUIRE		PROVIDED	
LOCATION	OPENABLE AREA	GLAZING AREA	OPENABLE AREA
A11-MBR	0.388	0.620	0.548
A13-MBR	0.388	0.620	1.495

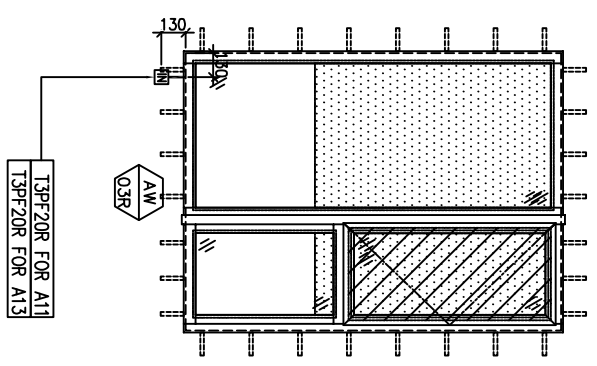
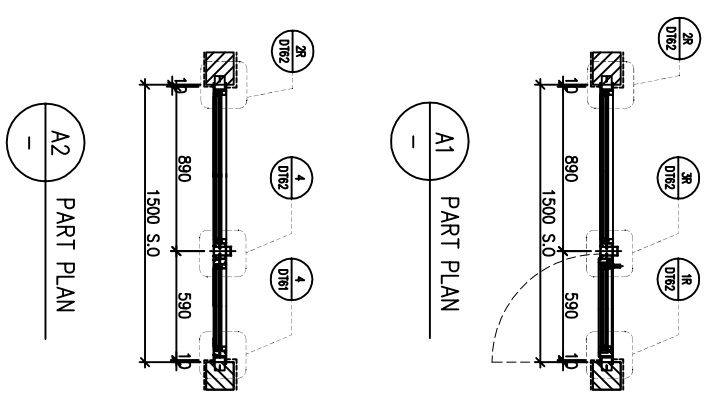
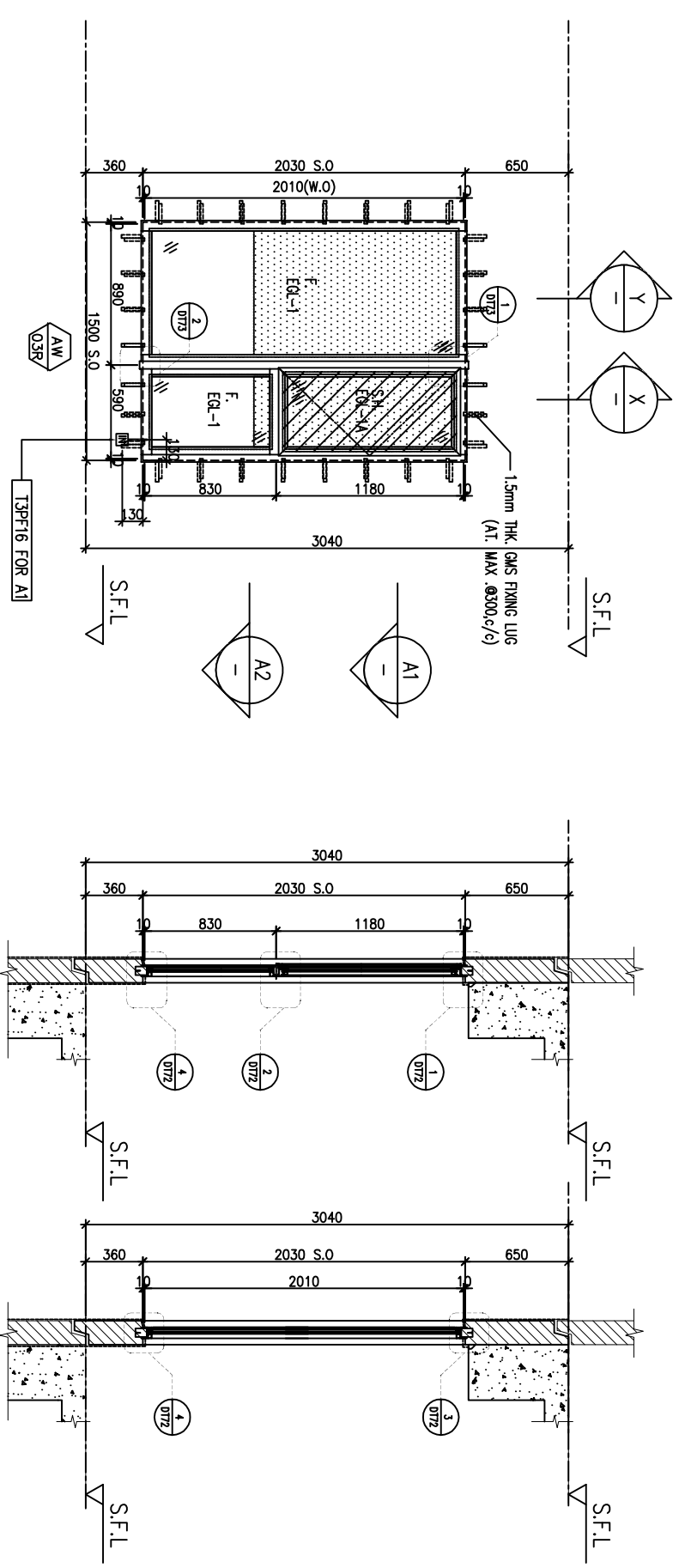

FACADE CODE		
LWK	鴻輝	UNIT
PF-20R	T3PF-41	A12
PF-20R	T3PF-44	A15

WINDOW MARK	AW Q3R
LOCATION	3/F-42/F(4/F,13/F,14/F,24/F,34/F OMITTED) UNIT {A12, A15}
SECTION	70mm ALUM. SECTION
GLAZING	EGL-1, EGL-1A
QUANTITY	35 Nos / 35 Nos
REMARKS	FACADE(TYPE T3PF20R FOR 3/F~42/F), 4 BAR HINGE-LIP HING (HHMS-N16)

BD. REF. :

CLIENT : **SUN HUNG KAI**
REAL ESTATE AGENCY LTD.
42/F SUN HUNG KAI CENTRE, WANCHAI, HONGKONG

ARCHITECT : **lwk&partners**
A R C H I T E C T S

MAIN CONTRACTOR : **怡輝建築有限公司**
Yee Fai Building Contractors Ltd.

STRUCTURAL ENGINEER : **ARUP**
ALPHA CONSULTING LIMITED
Steel Structure & Façade Specialist

FACADE CONSULTANT :

NOTE :

- ALL DIMENSIONS ARE IN mm.
- ALL ELEVATIONS ARE VIEWED FROM OUTSIDE.
- ALL DIMENSIONS TO BE VERIFIED ON SITE BEFORE FABRICATION.

LEGEND :

①1 --- DETAIL MARK NO.
①000 --- REEFER SHEET NO.

- F.F.L. --- FINISHED FLOOR LEVEL
- S.F.L. --- STRUCTURAL FLOOR LEVEL
- ② --- REVERSED DETAIL

4. GLASS LEGEND

EGL-1 --- 8mmHS+12mm AIR GAP+10mmTP THK. I.G.U.
EGL-2 --- 10mm THK. CLEAR TEMPERED GLASS
EGL-4 --- 10mm THK. TEMPERED ACID ETCHED GLASS
EGL-1A --- 8mmHS+12mm AIR GAP+8mmTP THK. I.G.U.
EGL-1B --- 8mmHS+12mm AIR GAP+10mmTP ACID-ETCHED THK. I.G.U.

NO.	DATE	REVISION	REVISION SUBJECT TO ARCH/COMMENT	BY
G	26/10/2022	REVISION SUBJECT TO GRP PLAN		h
F	21/09/2022	REVISION SUBJECT TO ARCH/COMMENT		h
E	17/08/2022	REVISION SUBJECT TO ARCH/COMMENT		h
D	22/04/2022	REVISION SUBJECT TO ARCH/COMMENT		h
C	09/04/2022	REVISION SUBJECT TO ARCH/COMMENT		h
B	14/12/2021	REVISION SUBJECT TO ARCH/COMMENT		h
A	18/10/2021	REVISION SUBJECT TO ARCH/COMMENT		h

JOB NO. : J-856

PROJECT : PROPOSED DEVELOPMENT ABOVE LIGHT RAIL TIN WING STOP-TSWTL NO.23,AREA 33,TIN SHUI WAI, N.T.

TITLE : WINDOW SCHEDULE FOR TOWER 3 ALUM. WINDOW

DATE : 02-Aug-21 SCALE : 1:40

DRAWN BY : IYVN CHECKED BY :

UNITED STATES OF AMERICA

美特鋁質有限公司
MIDI ALUMINUM FABRICATOR LTD.
Units 6-8, Sunray Industrial Centre, 1/F
610 Chee Kwo Ling Road, Kwai Tsoum
Tel:23489211-4 Fax:(852)2727666

DWG NO. : JB56-SD-PW-5312 REV : G

B.D. REF :

CLIENT :

SUN HUNG KAI
REAL ESTATE AGENCY LTD.
42/F SUN HUNG KAI CENTRE, WANCHAI, HONGKONG

ARCHITECT :

lwk&partners
a r c h i t e c t s

MAIN CONTRACTOR :

怡輝建築有限公司
Yee Fai
Building Contractors Ltd.

STRUCTURAL ENGINEER :

ARUP

FAÇADE CONSULTANT:

ALPHA CONSULTING LIMITED
Steel Structure & Façade Specialist

ELEVATION

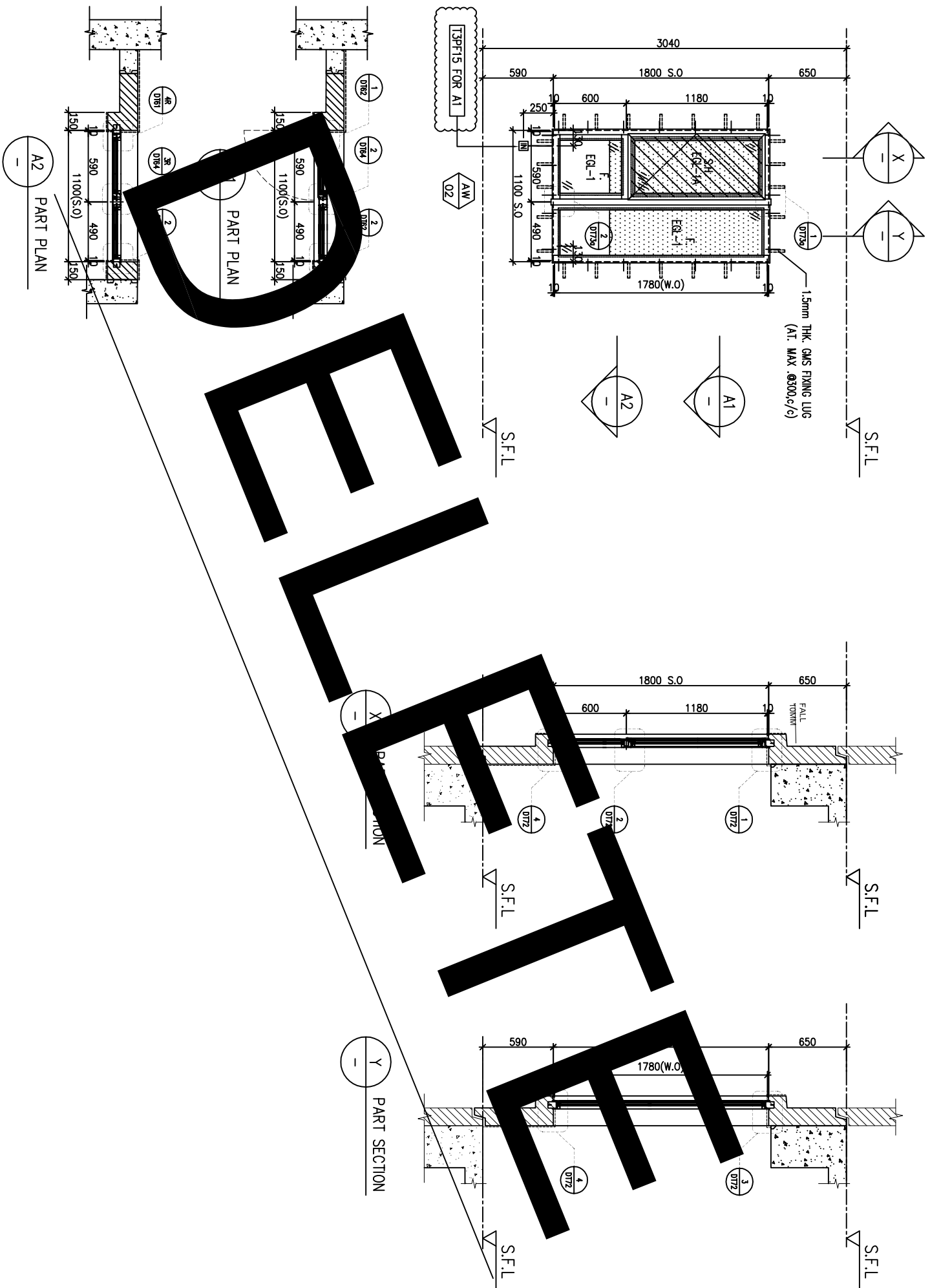

WINDOW MARK	AW 02
LOCATION	3/F-42/F(4/F,13/F,14/F,24/F,34/F OMITTED) UNIT A1
SECTION	70mm ALUM. SECTION
GLAZING	EGL-1, EGL-1A
QUANTITY	35 Nos.
REMARKS	FAÇADE(TYPE T3PF02 FOR 3/F-42/F)

NOTE :

1. ALL DIMENSIONS ARE IN mm.
2. ALL ELEVATIONS ARE VIEWED FROM OUTSIDE.
3. ALL DIMENSIONS TO BE VERIFIED ON SITE BEFORE FABRICATION.

LEGEND :

- (X1) --- DETAIL MARK NO.
- (X001) --- REFER SHEET NO.

1. F.F.L. --- FINISHED FLOOR LEVEL
2. S.F.L. --- STRUCTURAL FLOOR LEVEL
3. (R) --- REVERSED DETAIL

4. GLASS LEGEND

- EGL-1 --- 8mmHS+12mm AIR GAP+10mmTP THK. I.G.U.
- EGL-2 --- 10mm THK. CLEAR TEMPERED GLASS
- EGL-4 --- 10mm THK. TEMPERED ACID ETCHED GLASS
- EGL-1A --- 8mmHS+12mm AIR GAP+8mmTP THK. I.G.U.
- EGL-1B --- 8mmHS+12mm AIR GAP+10mmTP ACID-ETCHED THK. I.G.U.

NO.	DATE	REVISION	BY
D	08/04/2022	REVISION SUBJECT TO ARCH.COMMENT	hwn
C	21/12/2021	REVISION SUBJECT TO ARCH.COMMENT	hwn
B	18/10/2021	REVISION SUBJECT TO ARCH.COMMENT	hwn
A	12/10/2021	REVISION SUBJECT TO ARCH.COMMENT	hwn

JOB NO. : J-856

PROJECT : PROPOSED DEVELOPMENT ABOVE LIGHT RAIL TIN WING STOP-TSWTL NO.23,AREA 33,TIN SHUI WAI, N.T.

TITLE : WINDOW SCHEDULE FOR TOWER 3 ALUM. WINDOW

DATE : 02-Aug-21 SCALE : 1:40

DRAWN BY : hwn CHECKED BY :

美特铝质有限公司
MIDI ALUMINUM FABRICATOR LTD.
Units 6-8, Sunray Industrial Centre, 1/F
610 Chee Kwo Ling Road, Kwai Tsing
Tel:23489211-4 Fax:(852)2727666
DWG NO. : JB56-SD-PW-5313 REV : D

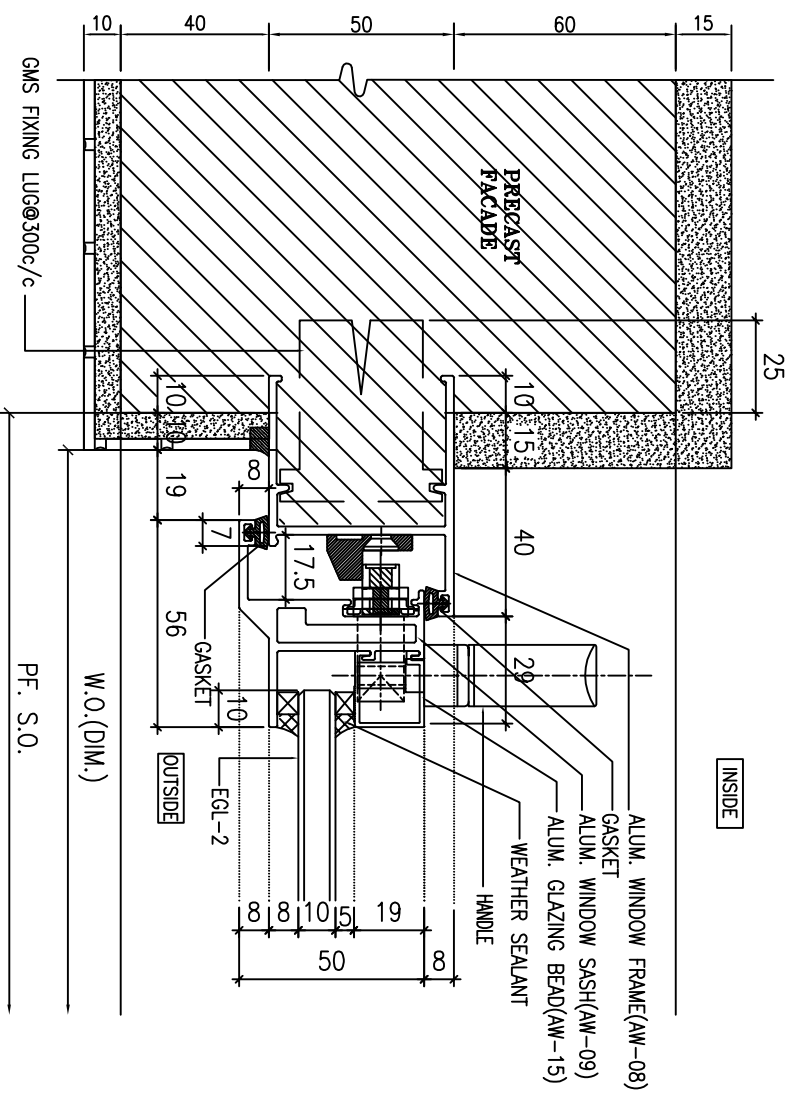

1 HORIZONTAL DETAIL
SCALE 1:2

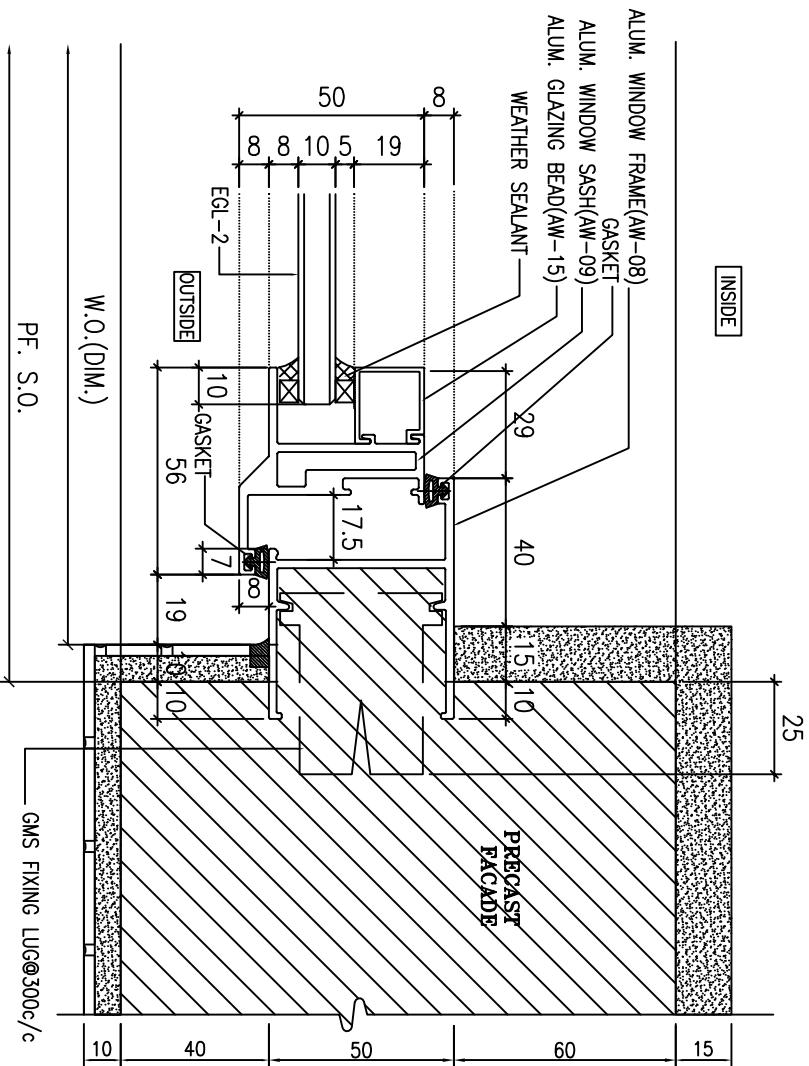

2 HORIZONTAL DETAIL
SCALE 1:2

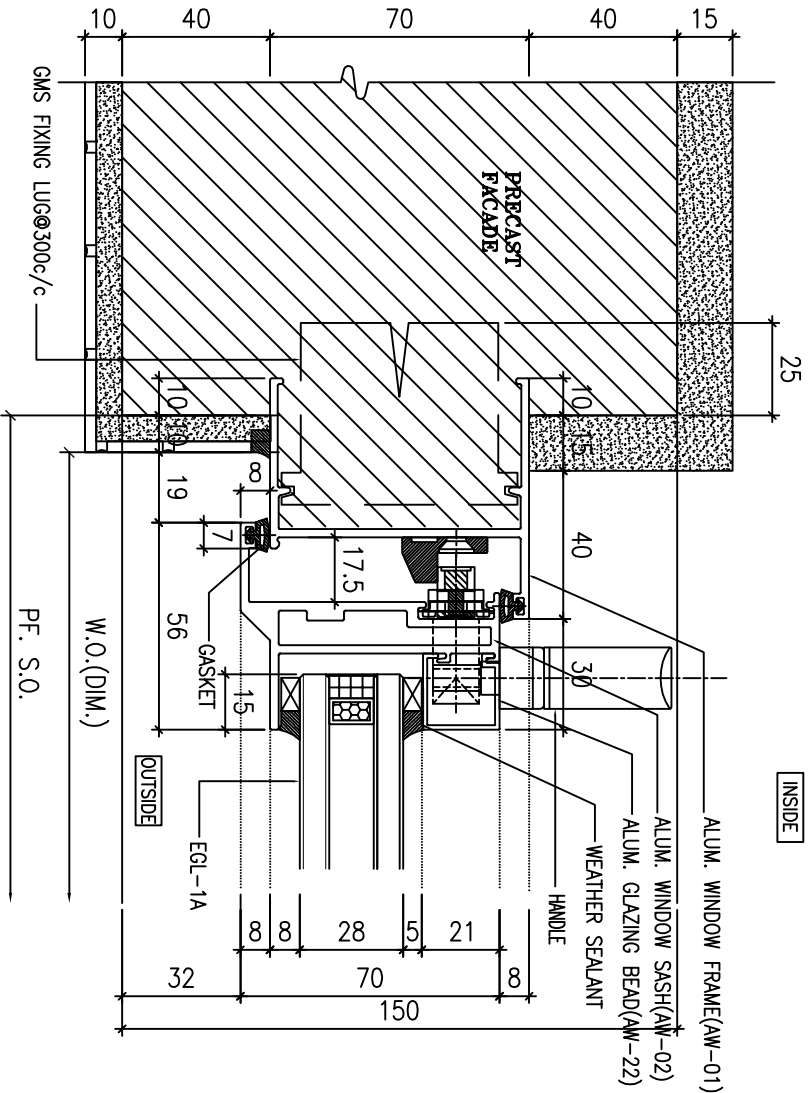

3 HORIZONTAL DETAIL
SCALE 1:2

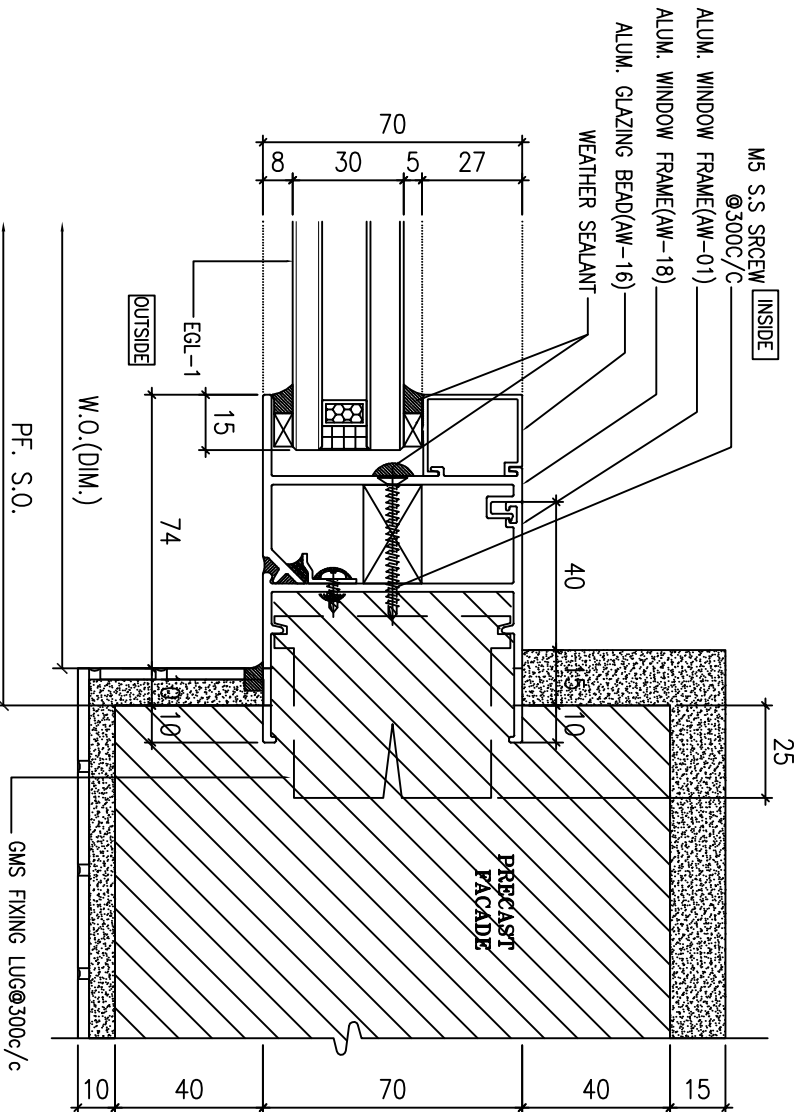

4 HORIZONTAL DETAIL
SCALE 1:2

B.D. REF :

CLIENT :

SUN HUNG KAI
REAL ESTATE AGENCY LTD.
42/F SUN HUNG KAI CENTRE, WANCHAI, HONGKONG

ARCHITECT :

lwk&partners
ARCHITECTS

MAIN CONTRACTOR :

Yee Fai
Building Contractors Ltd.

STRUCTURAL ENGINEER :

ARUP
ALPHA CONSULTING LIMITED
Steel Structure & Façade Specialist

FAÇADE CONSULTANT :

ARUP
ALPHA CONSULTING LIMITED
Steel Structure & Façade Specialist

NOTE :

1. ALL DIMENSIONS ARE IN mm.
2. ALL ELEVATIONS ARE VIEWED FROM OUTSIDE.
3. ALL DIMENSIONS TO BE VERIFIED ON SITE BEFORE FABRICATION.

LEGEND :

(X1)	DETAIL MARK NO.
(X001)	REFER SHEET NO.

REVISIONS :

NO.	DATE	REVISION	BY
C	25/08/2022	REVISION SUBJECT TO ARCH/COMMENT	HW
B	02/11/2021	REVISION SUBJECT TO ARCH/COMMENT	HW
A	30/10/2021	REVISION SUBJECT TO ARCH/COMMENT	HW

TITLE :

TYPICAL DETAILS FOR ALUM. WINDOW

DATE : 02-Aug-21 SCALE : 1:40
DRAWN BY : IYON CHECKED BY :

JOB NO. : J-856
PROJECT : PROPOSED DEVELOPMENT ABOVE LIGHT RAIL TIN WING STOP TSWLT NO.23, AREA 33, TIN SHUI WAI, N.T.
MIDI ALUMINUM FABRICATOR LTD.
Units 6-8, Sunny Industrial Centre, 1/F
610 Chee Kwo Ling Road, Kwai Tsoum
Tel:23499211-4 Fax:(852)27272666
DWG NO. : J856-SD-PW-DT61 REV. : C

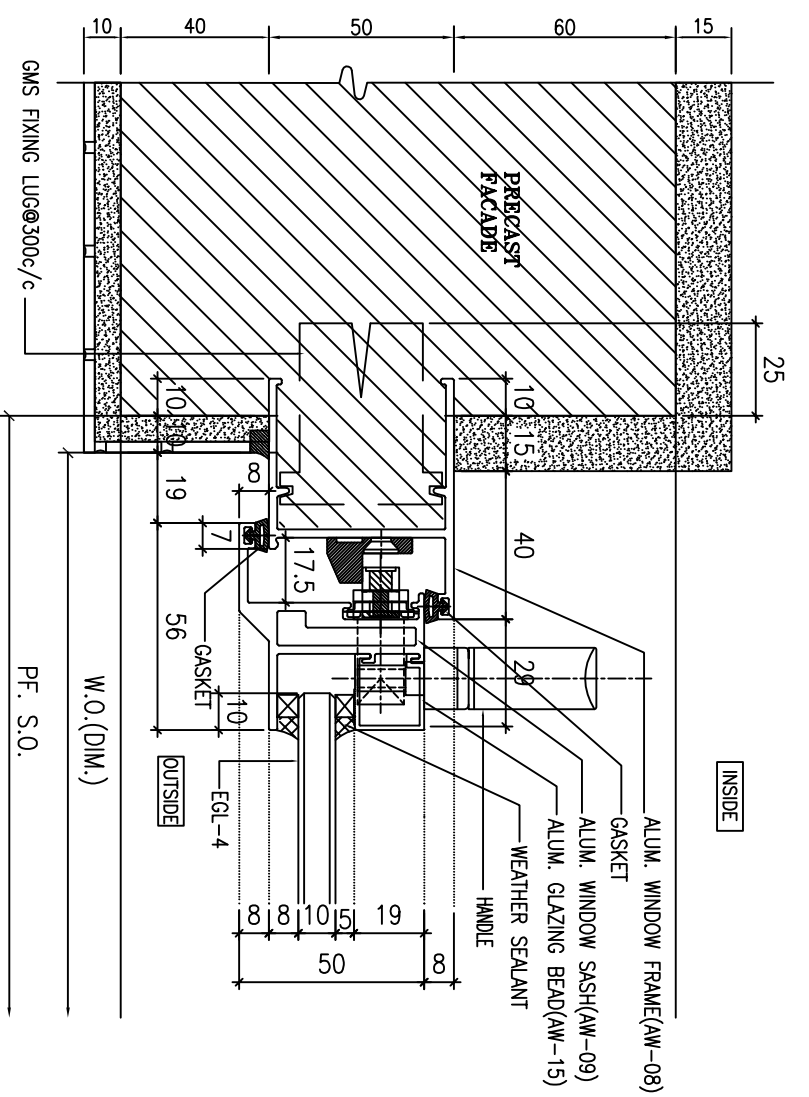

1 HORIZONTAL DETAIL
SCALE 1:2

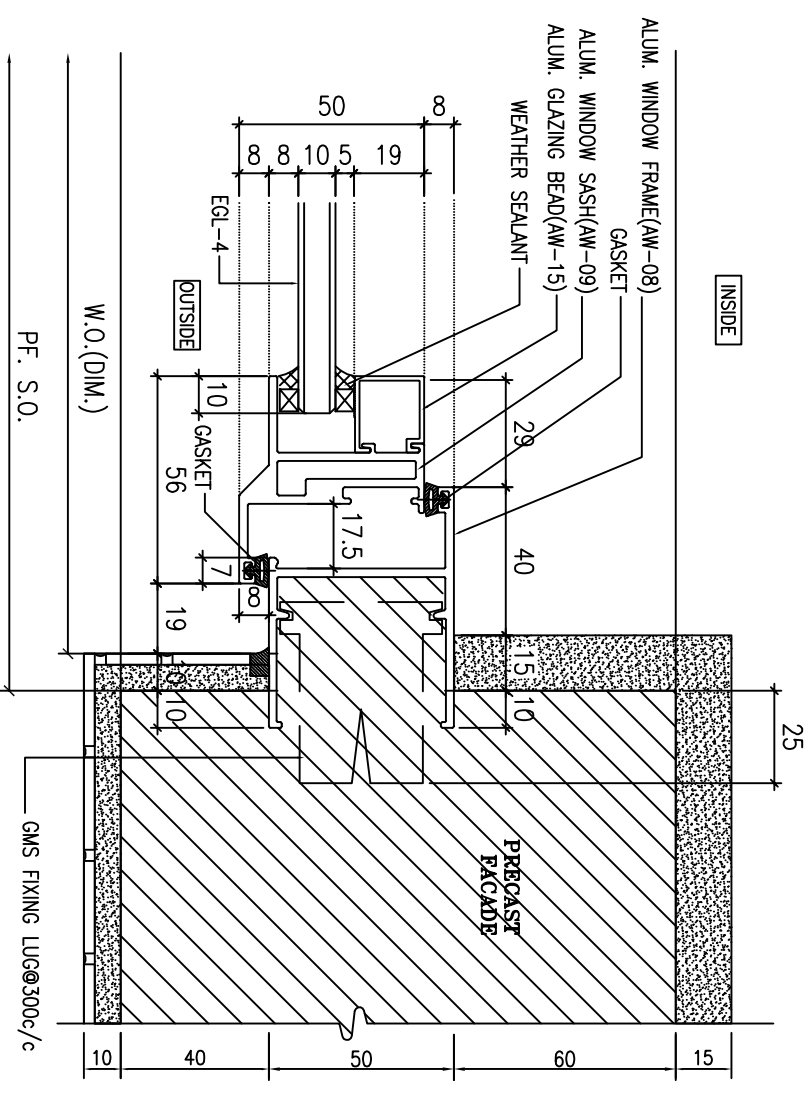

2 HORIZONTAL DETAIL
SCALE 1:2

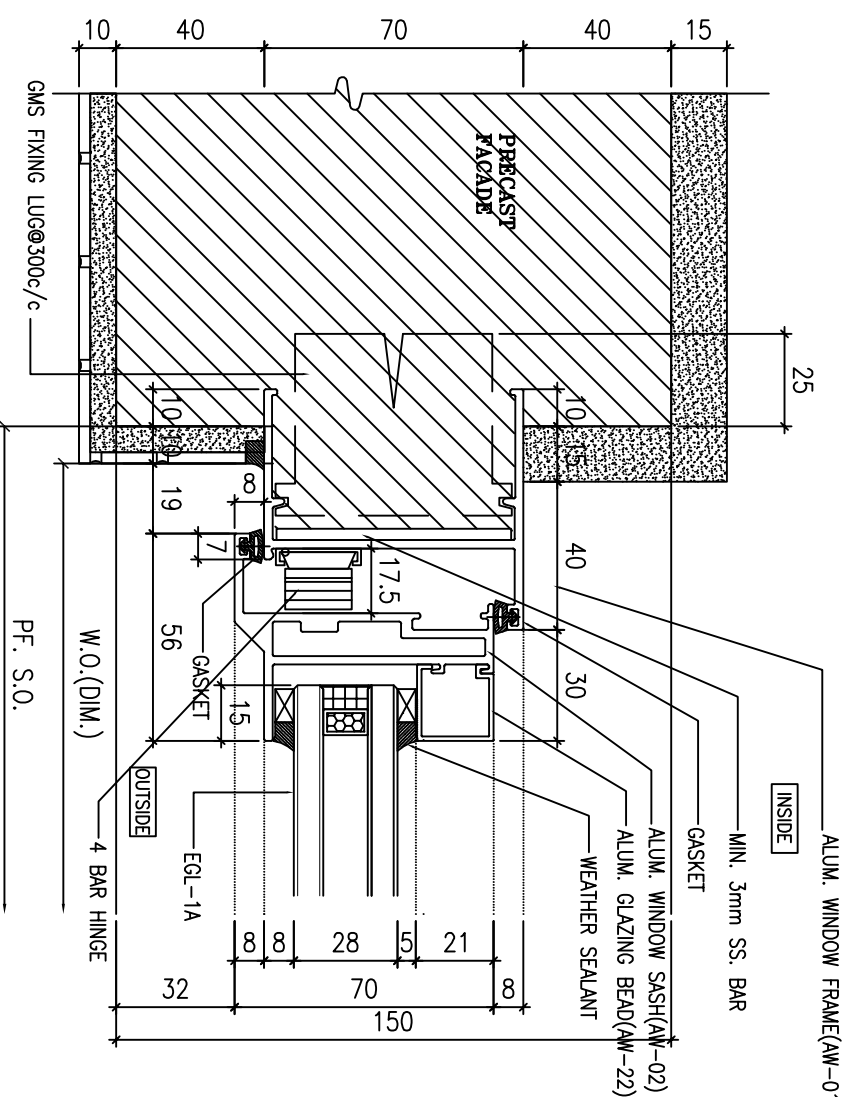

3 HORIZONTAL DETAIL
SCALE 1:2

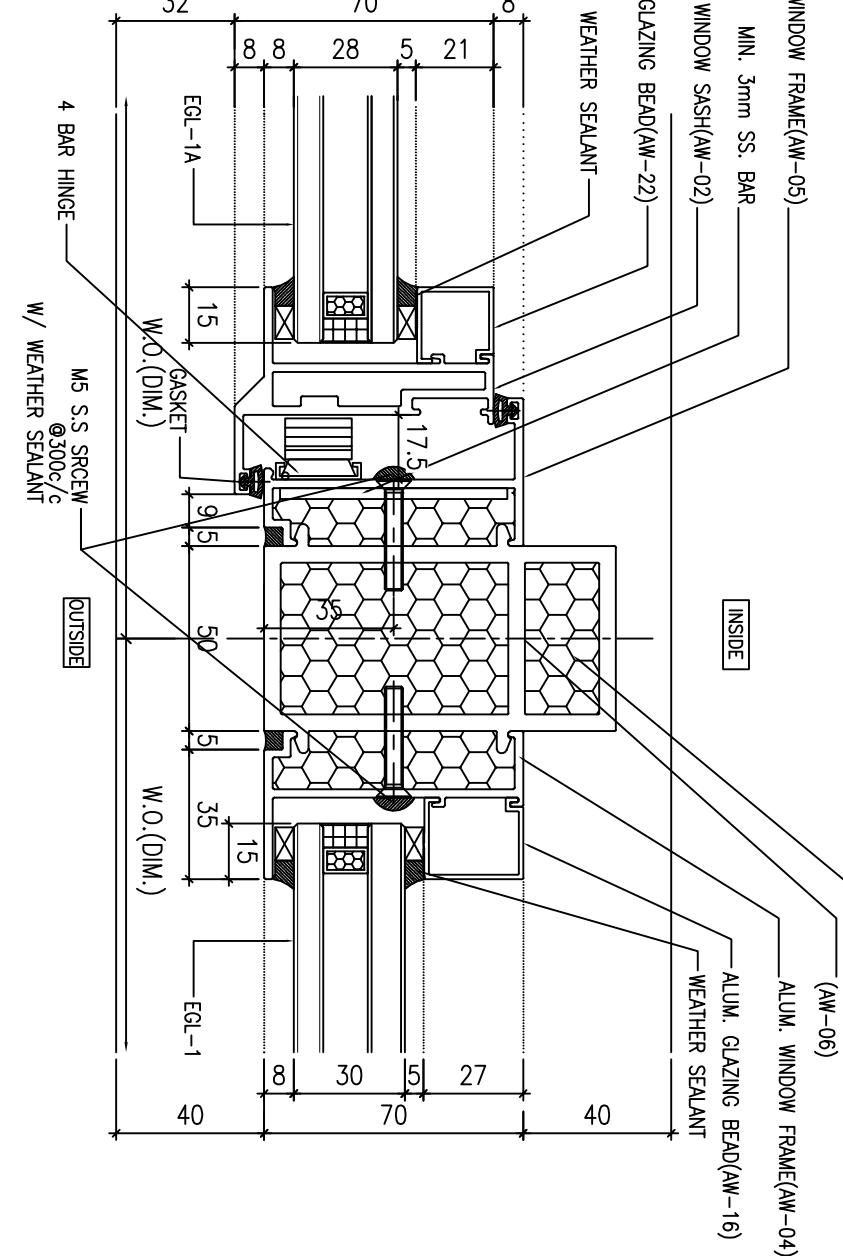

4 HORIZONTAL DETAIL
SCALE 1:2

B.D. REF :

CLIENT :

SUN HUNG KAI
REAL ESTATE AGENCY LTD.
42/F SUN HUNG KAI CENTRE, WANCHAI, HONGKONG

ARCHITECT :

IWK&partners
ARCHITECTS

MAIN CONTRACTOR :

Yee Fai
Building Contractors Ltd.

STRUCTURAL ENGINEER :

ARUP
ALPHA CONSULTING LIMITED
Steel Structure & Façade Specialist

FAÇADE CONSULTANT :

NOTE :

1. ALL DIMENSIONS ARE IN mm.
2. ALL ELEVATIONS ARE VIEWED FROM OUTSIDE.
3. ALL DIMENSIONS TO BE VERIFIED ON SITE BEFORE FABRICATION.

LEGEND :

X1	DETAIL MARK NO.
X001	REFER SHEET NO.
(F.L.)	FINISHED FLOOR LEVEL
(S.F.L.)	STRUCTURAL FLOOR LEVEL
(R)	REVERSED DETAIL
4.	GLASS LEGEND
EGL-1	8mmH5+12mm AIR GAP+10mmTP THK. I.G.U.
EGL-2	10mm THK. CLEAR TEMPERED GLASS
EGL-4	10mm THK. TEMPERED ACID ETCHED GLASS
EGL-1A	8mmH5+12mm AIR GAP+8mmTP THK. I.G.U.

JOB NO. : J-856

PROJECT : PROPOSED DEVELOPMENT ABOVE LIGHT RAIL TIN WING STOP TSWTL NO.23,AREA 33,TIN SHUI WAI, N.T.

TITLE : TYPICAL DETAILS FOR ALUM. WINDOW

DATE : 02-Aug-21 SCALE : 1:40

美特鋁質有限公司
MIDI ALUMINUM FABRICATOR LTD.
Units 6-8, Sunny Industrial Centre, Kwailoon
610 Cho Kwai Ling Road, Kwailoon
Tel:23489211-4 Fax:(852)27727666

DWG NO. : J856-SD-PW-DT61d REV. : C

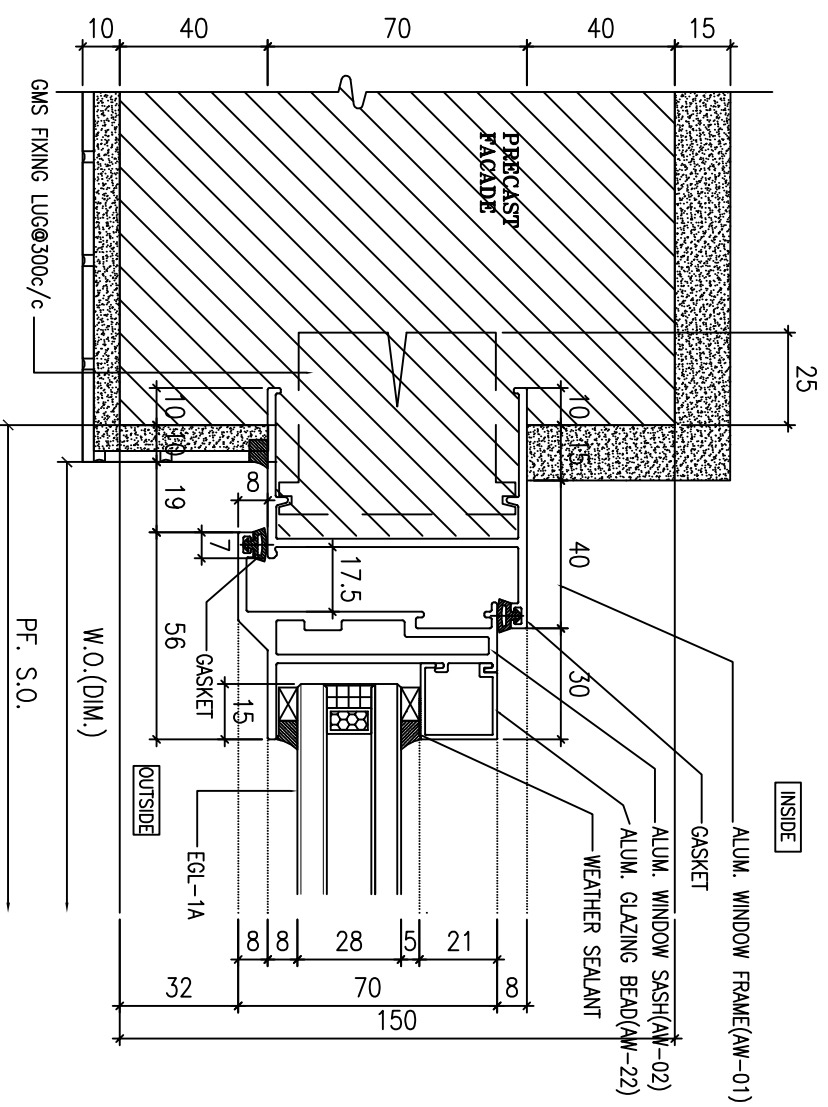

1 HORIZONTAL DETAIL
SCALE 1:2

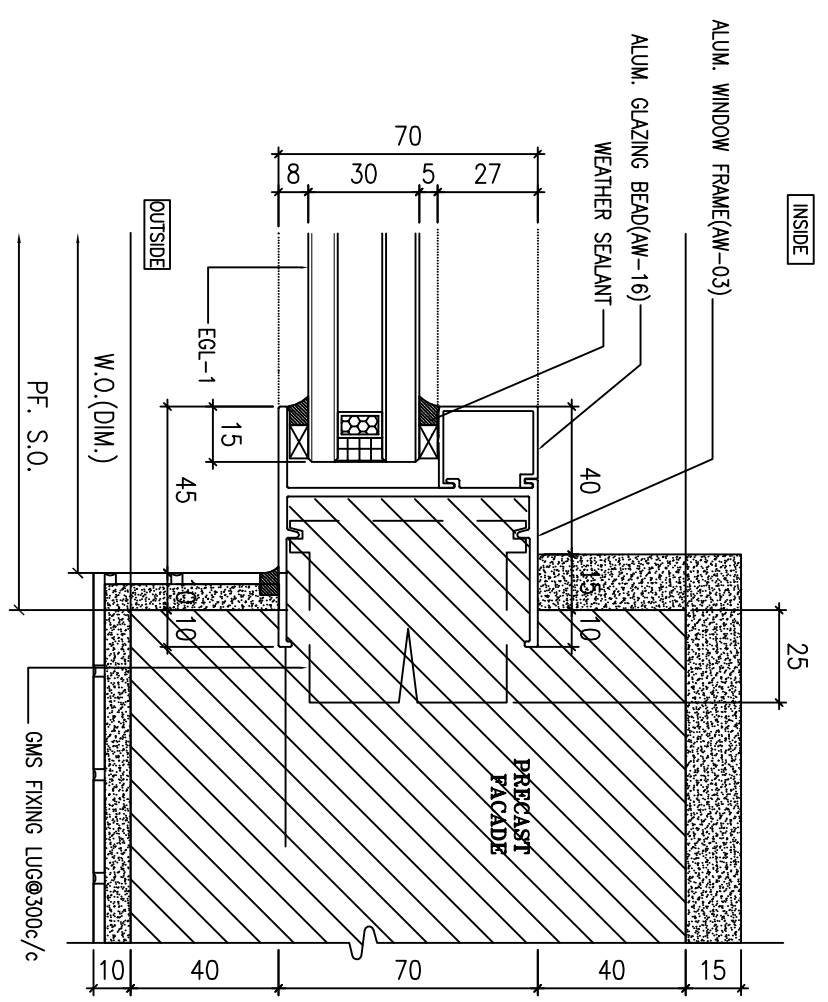

2 HORIZONTAL DETAIL
SCALE 1:2

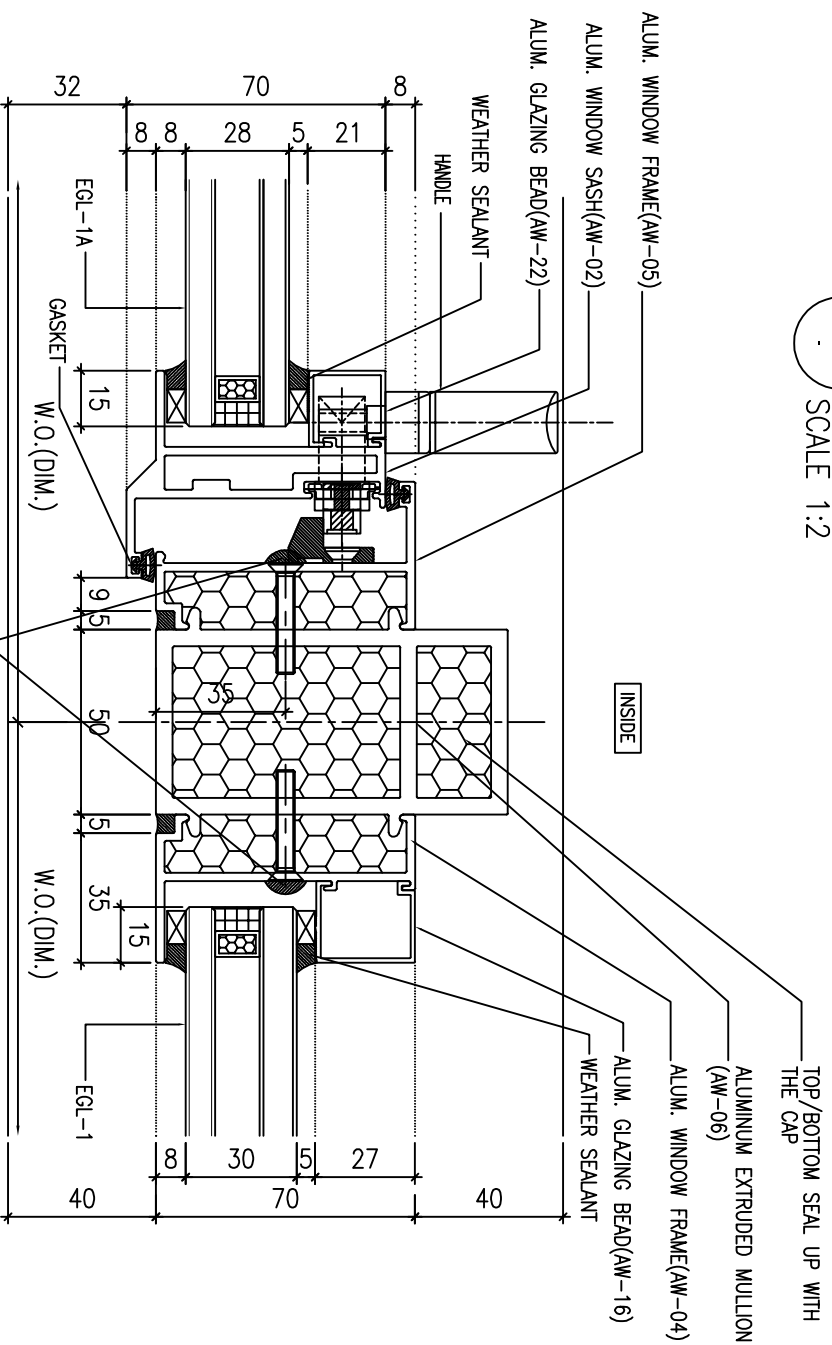

3 HORIZONTAL DETAIL
SCALE 1:2

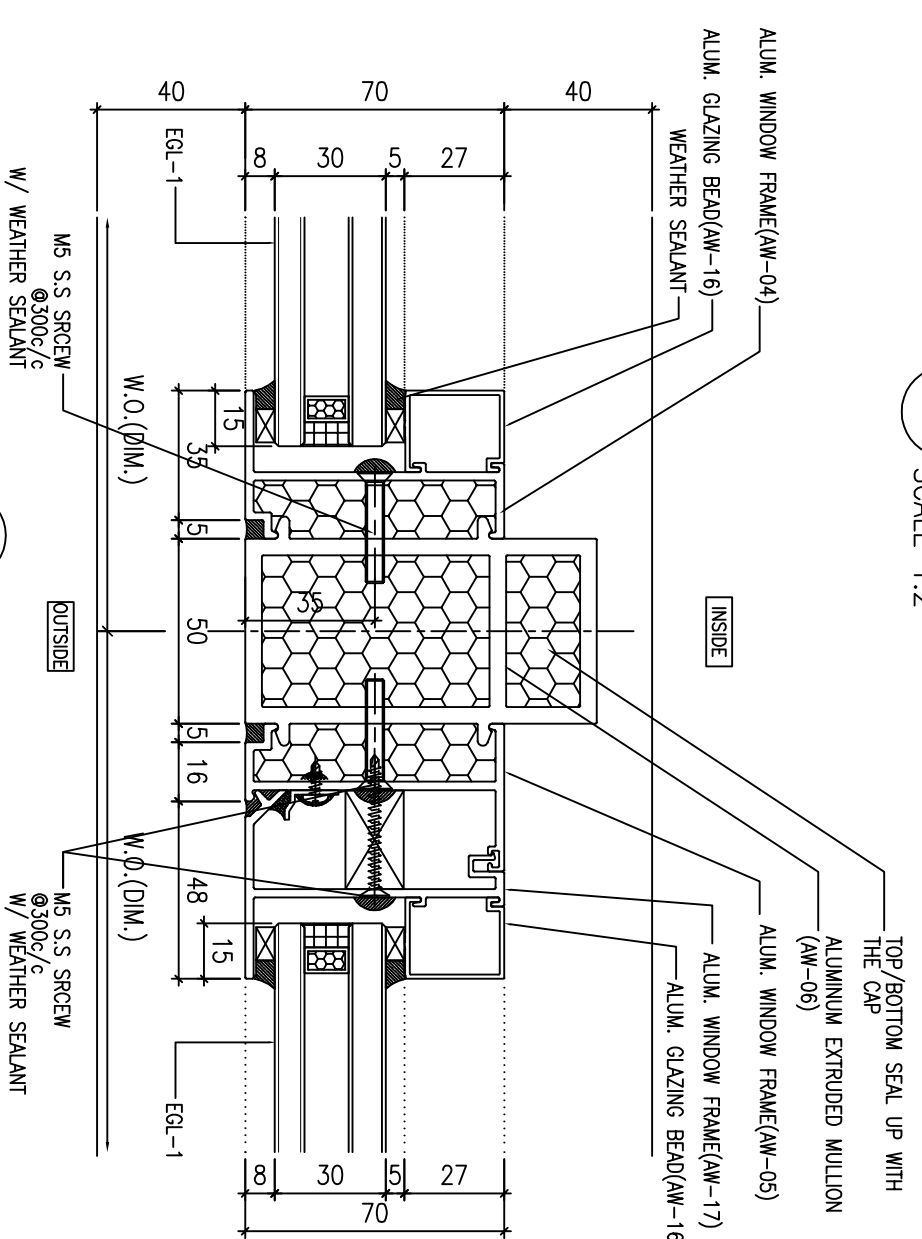

4 HORIZONTAL DETAIL
SCALE 1:2

B.D. REF :

CLIENT :

SUN HUNG KAI
REAL ESTATE AGENCY LTD.
42/F SUN HUNG KAI CENTRE, WANCHAI, HONGKONG

ARCHITECT :

lwk&partners
ARCHITECTS

MAIN CONTRACTOR :

怡輝建築有限公司
Yee Fai Building Contractors Ltd.

STRUCTURAL ENGINEER :

ARUP

FAÇADE CONSULTANT :

ALPHA CONSULTING LIMITED
Steel Structure & Façade Specialist

NOTE :

1. ALL DIMENSIONS ARE IN mm.
2. ALL ELEVATIONS ARE VIEWED FROM OUTSIDE.
3. ALL DIMENSIONS TO BE VERIFIED ON SITE BEFORE FABRICATION.

LEGEND :

- (X1) --- DETAIL MARK NO.
- (X001) --- REFER SHEET NO.

1. F.F.L. --- FINISHED FLOOR LEVEL
2. S.F.L. --- STRUCTURAL FLOOR LEVEL
3. (R) --- REVERSED DETAIL
4. GLASS LEGEND

- EGL-1 --- 8mmH+12mm AIR GAP+10mmTP THK. I.G.U.
- EGL-2 --- 10mm THK. CLEAR TEMPERED GLASS
- EGL-4 --- 10mm THK. TEMPERED ACID ETCHED GLASS
- EGL-1A --- 8mmH+12mm AIR GAP+8mmTP THK. I.G.U.

NO.	DATE	BY	REVISION
0	23/08/2022		REVISION SUBJECT TO ARCH/COMMENT
C	02/11/2021		REVISION SUBJECT TO ARCH/COMMENT
B	30/10/2021		REVISION SUBJECT TO ARCH/COMMENT
A	30/09/2021		REVISION SUBJECT TO ARCH/COMMENT

JOB NO. : J-856

PROJECT :

PROPOSED DEVELOPMENT ABOVE LIGHT RAIL TIN WING STOP-TS/WTL NO.23, AREA 33, TIN SHUI WAI, N.T.

TITLE :

TYPICAL DETAILS FOR ALUM. WINDOW

DATE : 02-Aug-21 SCALE : 1:40

DRAWN BY : IYON CHECKED BY :

美特鋁質有限公司
MIDI ALUMINUM FABRICATOR LTD.
Units 6-8, Sunny Industrial Centre, 1/F
610 Cho Kwo Ling Road, Kowloon
Tel:23489211-4 Fax:(852)27272666

DWG NO. : J856-SD-PW-DT62 REV. : D

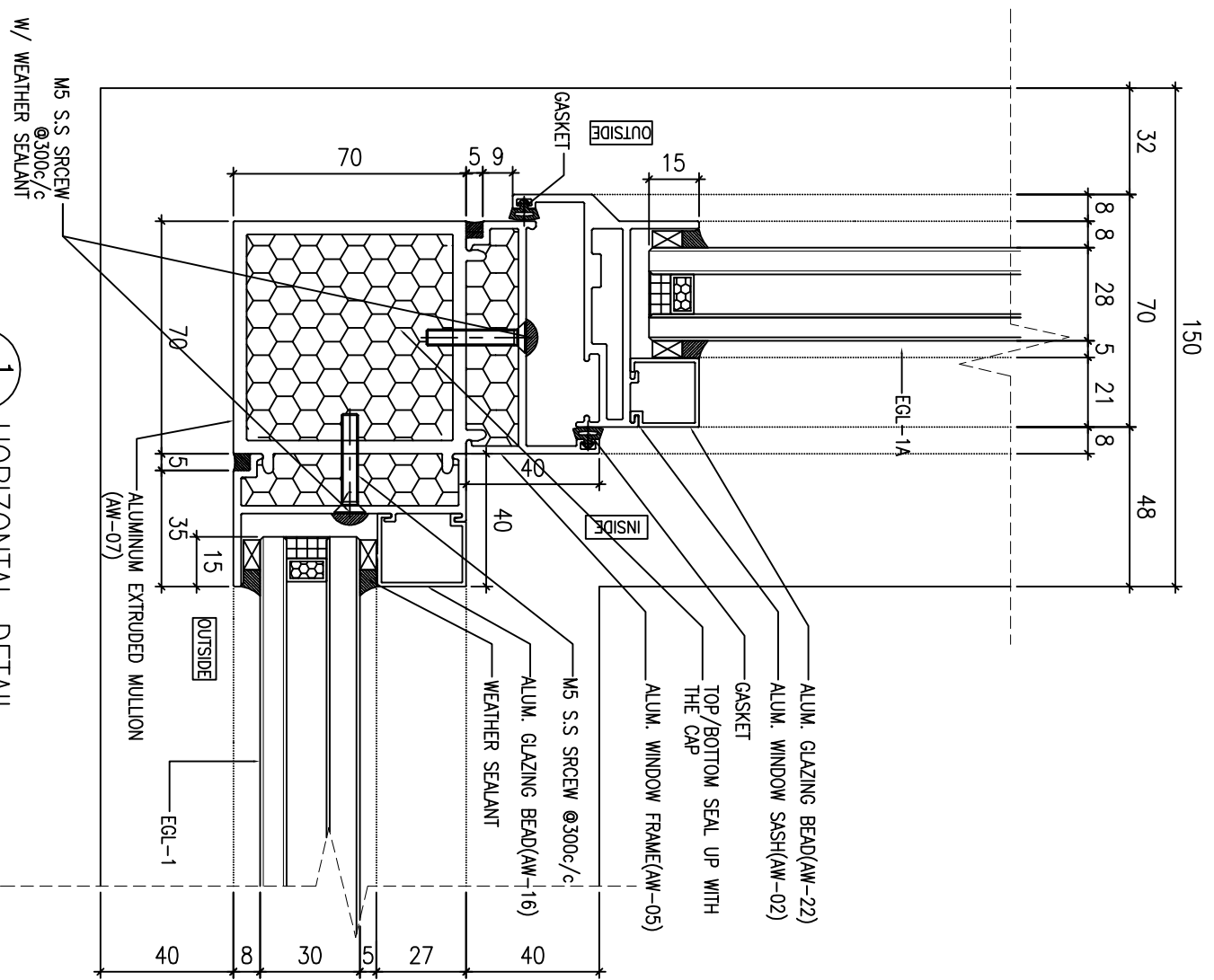

1 HORIZONTAL DETAIL
SCALE 1:2

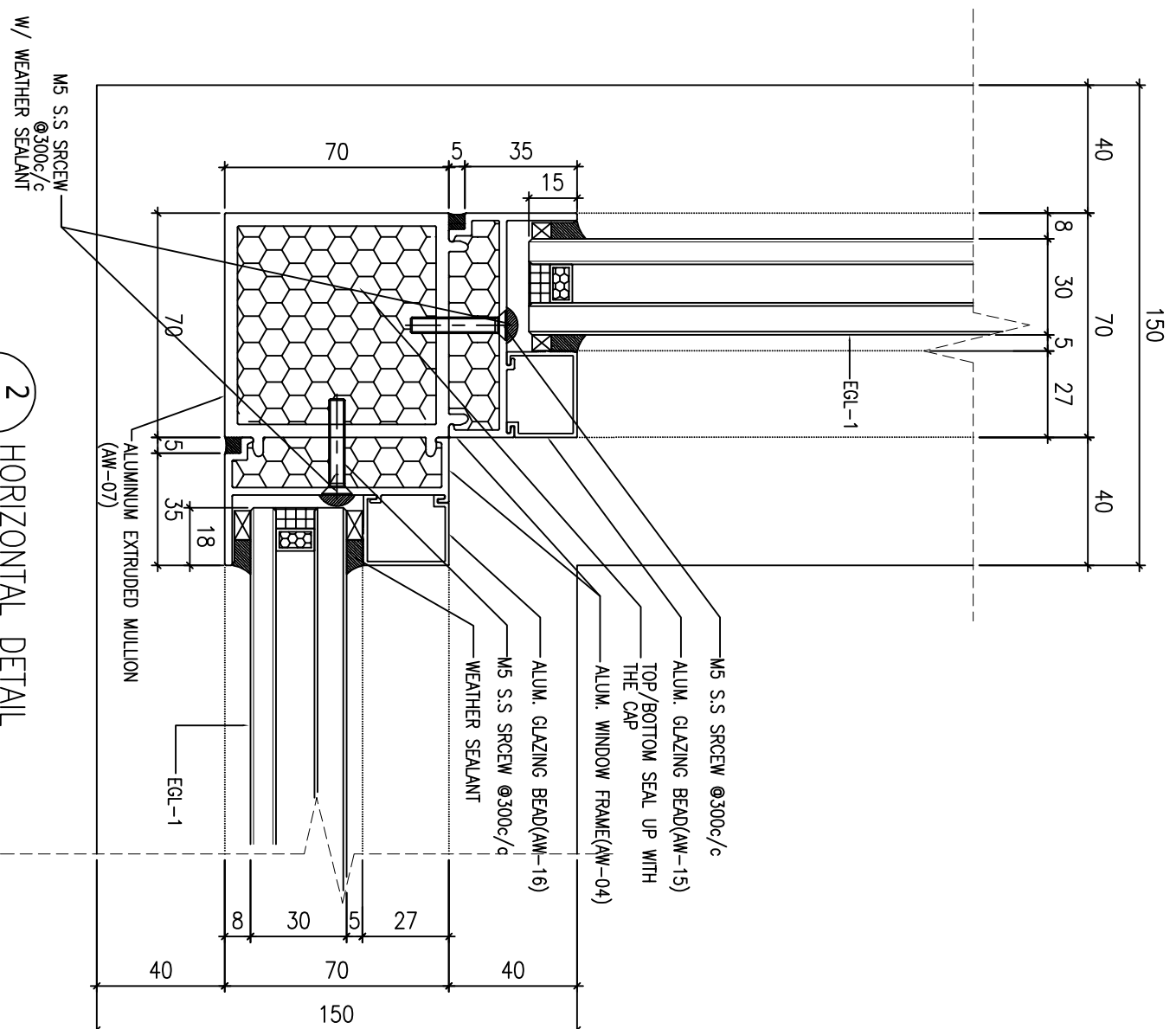

2 HORIZONTAL DETAIL
SCALE 1:2

B.D. REF :

CLIENT :

SUN HUNG KAI
REAL ESTATE AGENCY LTD.
42/F SUN HUNG KAI CENTRE, WANCHAI, HONGKONG

ARCHITECT :

lwk&partners
a r c h i t e c t s

MAIN CONTRACTOR :

Yee Fai 怡輝建築有限公司
Building Contractors Ltd.

STRUCTURAL ENGINEER :

ARUP

FAÇADE CONSULTANT :

ALPHA CONSULTING LIMITED
Steel Structure & Façade Specialist

- NOTE :
1. ALL DIMENSIONS ARE IN mm.
 2. ALL ELEVATIONS ARE VIEWED FROM OUTSIDE.
 3. ALL DIMENSIONS TO BE VERIFIED ON SITE BEFORE FABRICATION.

LEGEND :

(X1) --- DETAIL MARK NO.
(X001) --- REFER SHEET NO.

1. F.F.L. --- FINISHED FLOOR LEVEL
2. S.F.L. --- STRUCTURAL FLOOR LEVEL
3. (R) --- REVERSED DETAIL

4. GLASS LEGEND

- EQ-1-1 --- 8mmH5+12mm AIR GAP+10mmTP THK. I.G.U.
EQ-2-2 --- 10mm THK. CLEAR TEMPERED GLASS
EQ-4-4 --- 10mm THK. TEMPERED ACID ETCHED GLASS
EQ-11A-8mmH5+12mm AIR GAP+8mmTP THK. I.G.U.

NO.	DATE	REVISION	BY
D	23/08/2022	REVISION SUBJECT TO ARCH/COMMENT	ivan
C	02/11/2021	REVISION SUBJECT TO ARCH/COMMENT	ivan
B	30/10/2021	REVISION SUBJECT TO ARCH/COMMENT	ivan
A	30/09/2021	REVISION SUBJECT TO ARCH/COMMENT	ivan

JOB NO. : J-856

PROJECT :

PROPOSED DEVELOPMENT ABOVE
LIGHT RAIL TIN WING STOP/TSWTL
NO.23,AREA 33,TIN SHUI WAI, N.T.

TITLE :

TYPICAL DETAILS FOR
ALUM. WINDOW

DATE : 02-Aug-21 SCALE : 1:40

DRAWN BY : ivan CHECKED BY :

美特鋁質有限公司
MIDI ALUMINUM FABRICATOR LTD.
Units 6-8, Sunray Industrial Centre, 1/F
610 Cho Kwai Ling Road, Kowloon
Tel:23489211-4 Fax:(852)27727666

DWG NO. : J856-SD-PW-0163 REV. : D

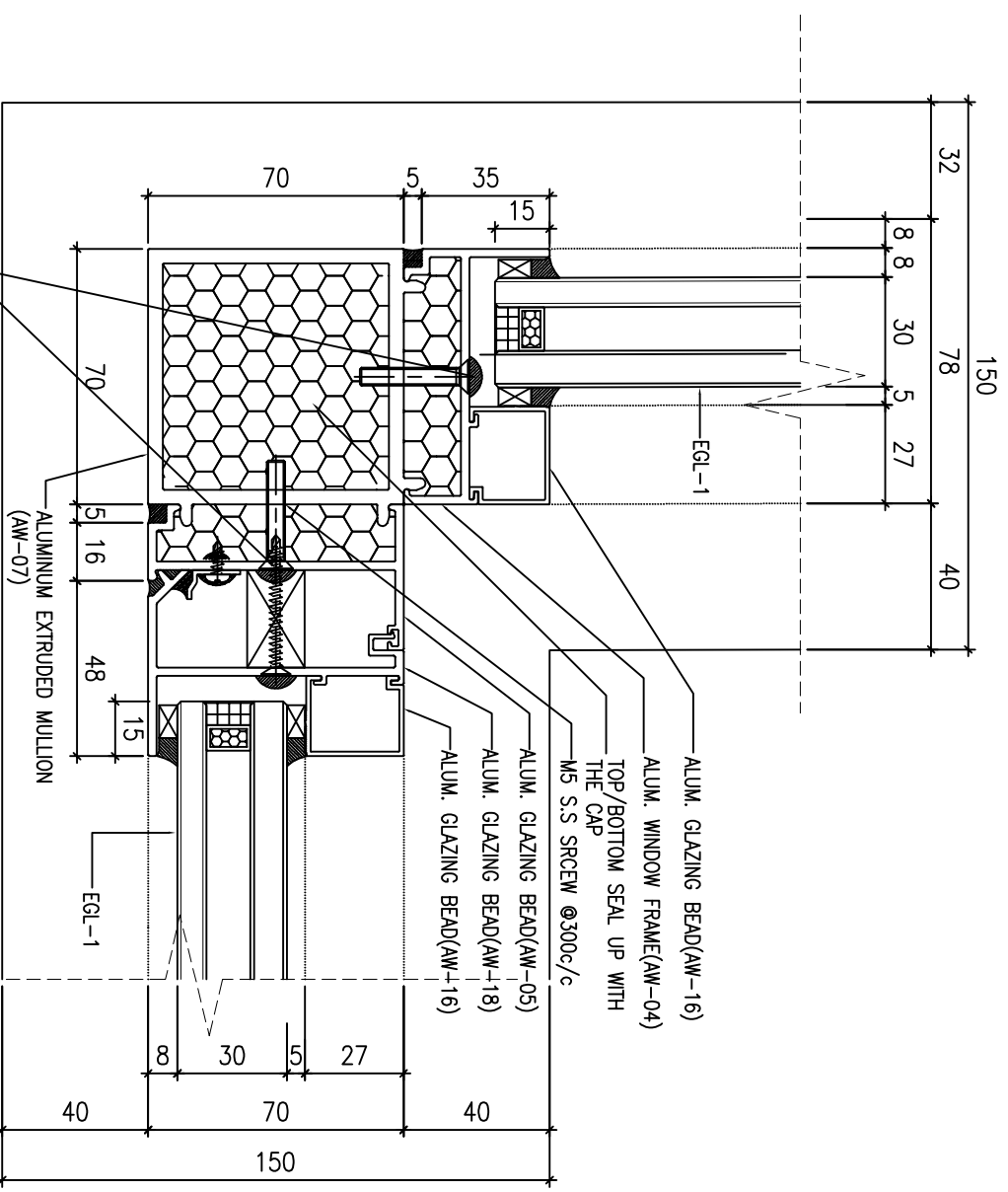

1 HORIZONTAL DETAIL
SCALE 1:2

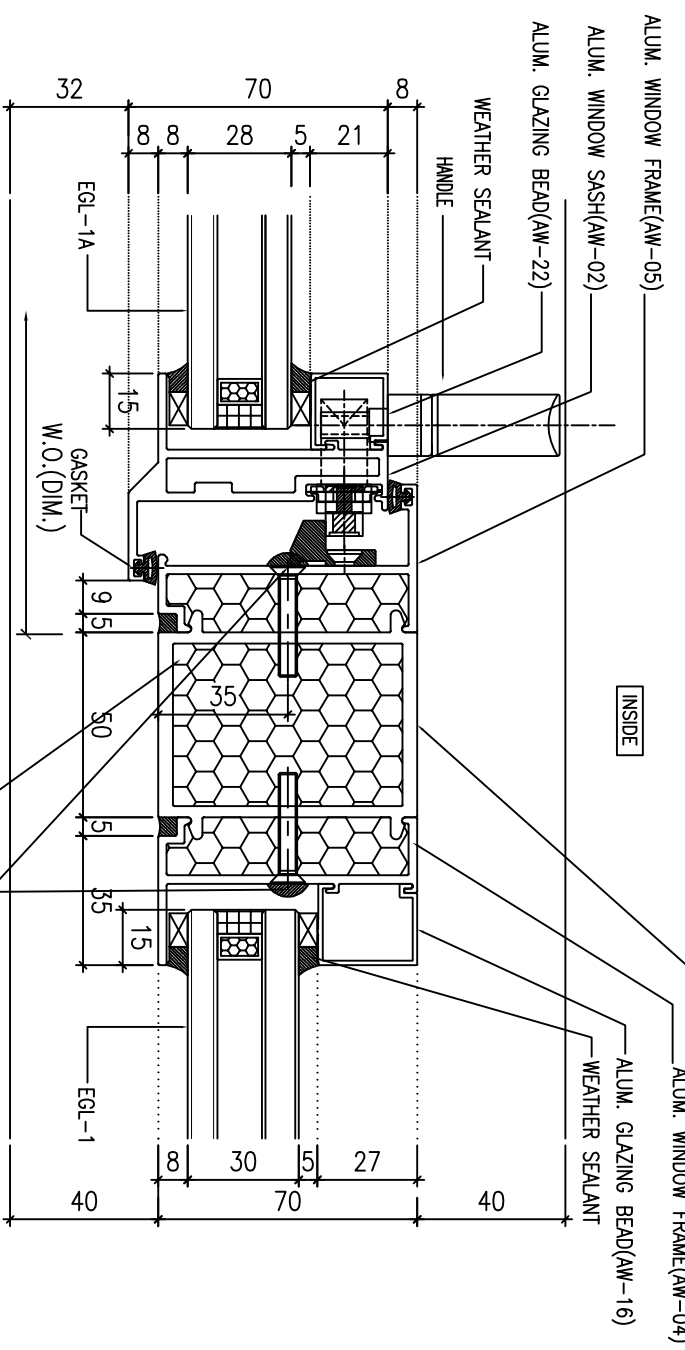

2 HORIZONTAL DETAIL
SCALE 1:2

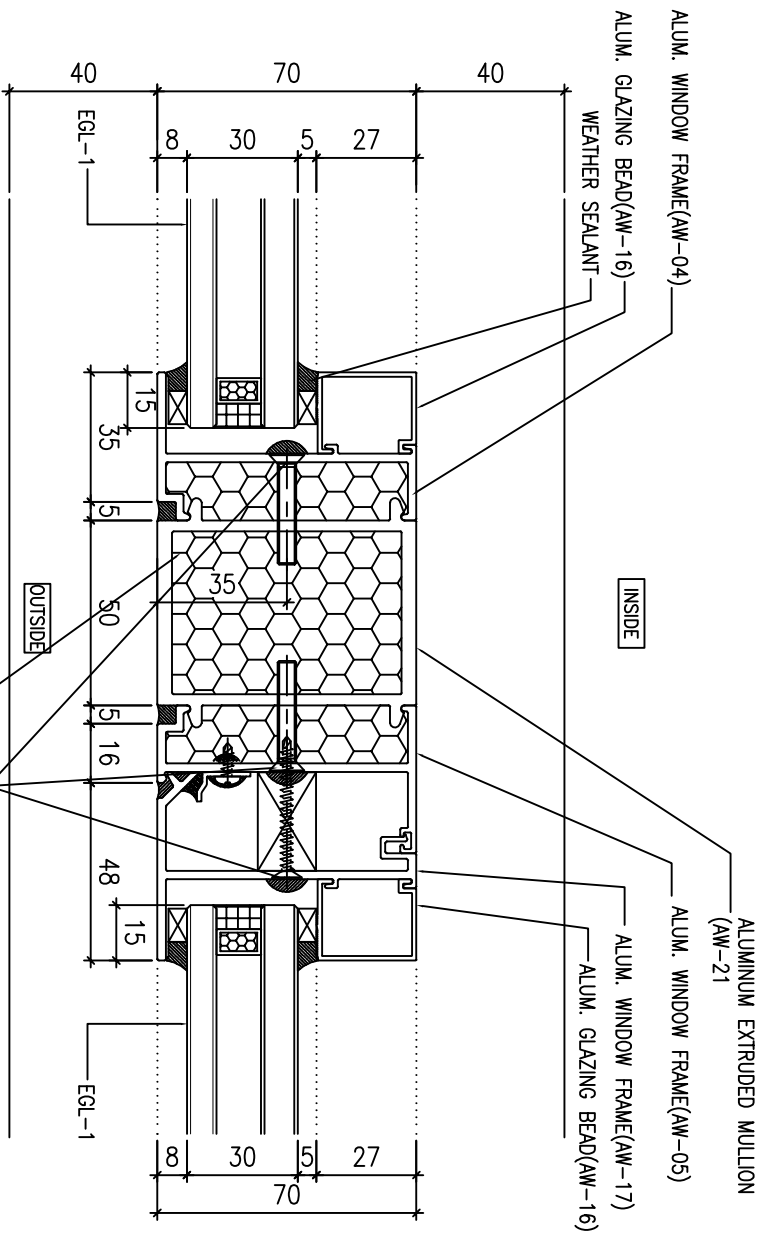

3 HORIZONTAL DETAIL
SCALE 1:2

B.D. REF :

CLIENT :

SUN HUNG KAI
REAL ESTATE AGENCY LTD.
42/F SUN HUNG KAI CENTRE, WANCHAI, HONGKONG

ARCHITECT :
lwk&partners
a r c h i t e c t s

MANU CONTRACTOR :
怡輝建築有限公司
Yee Fai Building Contractors Ltd.

STRUCTURAL ENGINEER :
ARUP
ALPHA CONSULTING LIMITED
Steel Structure & Facade Specialist

- NOTE:
1. ALL DIMENSIONS ARE IN mm.
2. ALL ELEVATIONS ARE VIEWED FROM OUTSIDE.
3. ALL DIMENSIONS TO BE VERIFIED ON SITE BEFORE FABRICATION.
- LEGEND:
X1 --- DETAIL MARK NO.
X001 --- REFER SHEET NO.

1. F.F.L. --- FINISHED FLOOR LEVEL
2. S.F.L. --- STRUCTURAL FLOOR LEVEL
3. (R) --- REVERSED DETAIL
4. GLASS LEGEND
EGL-1 --- 8mmH+12mm AIR GAP+10mmTP THK. I.G.U.
EGL-2 --- 10mm THK. CLEAR TEMPERED GLASS
EGL-4 --- 10mm THK. TEMPERED ACID ETCHED GLASS
EGL-1A --- 8mmH+12mm AIR GAP+8mmTP THK. I.G.U.

NO.	DATE	REVISION	BY
E	25/08/2022	REVISION SUBJECT TO ARCH/COMMENT	HW
D	02/11/2021	REVISION SUBJECT TO ARCH/COMMENT	HW
C	30/10/2021	REVISION SUBJECT TO ARCH/COMMENT	HW
B	18/10/2021	REVISION SUBJECT TO ARCH/COMMENT	HW
A	30/09/2021	REVISION SUBJECT TO ARCH/COMMENT	HW

JOB NO. : J-856
PROJECT : PROPOSED DEVELOPMENT ABOVE LIGHT RAIL TIN WING STOP TSMTL NO.23, AREA 33, TIN SHUI WAI, N.T.
TITLE : TYPICAL DETAILS FOR ALUM. WINDOW
DATE : 02-Aug-21 SCALE : 1:40
DRAWN BY : IYVN CHECKED BY :
REV. : E

美特鋁質有限公司
MIDI ALUMINUM FABRICATOR LTD.
Units 6-8, Sunny Industrial Centre, 1/F
610 Chee Kwo Ling Road, Kowloon
Tel: 23492111-4 Fax: (852) 27272666
DWG NO. : J856-SD-PW-DT64

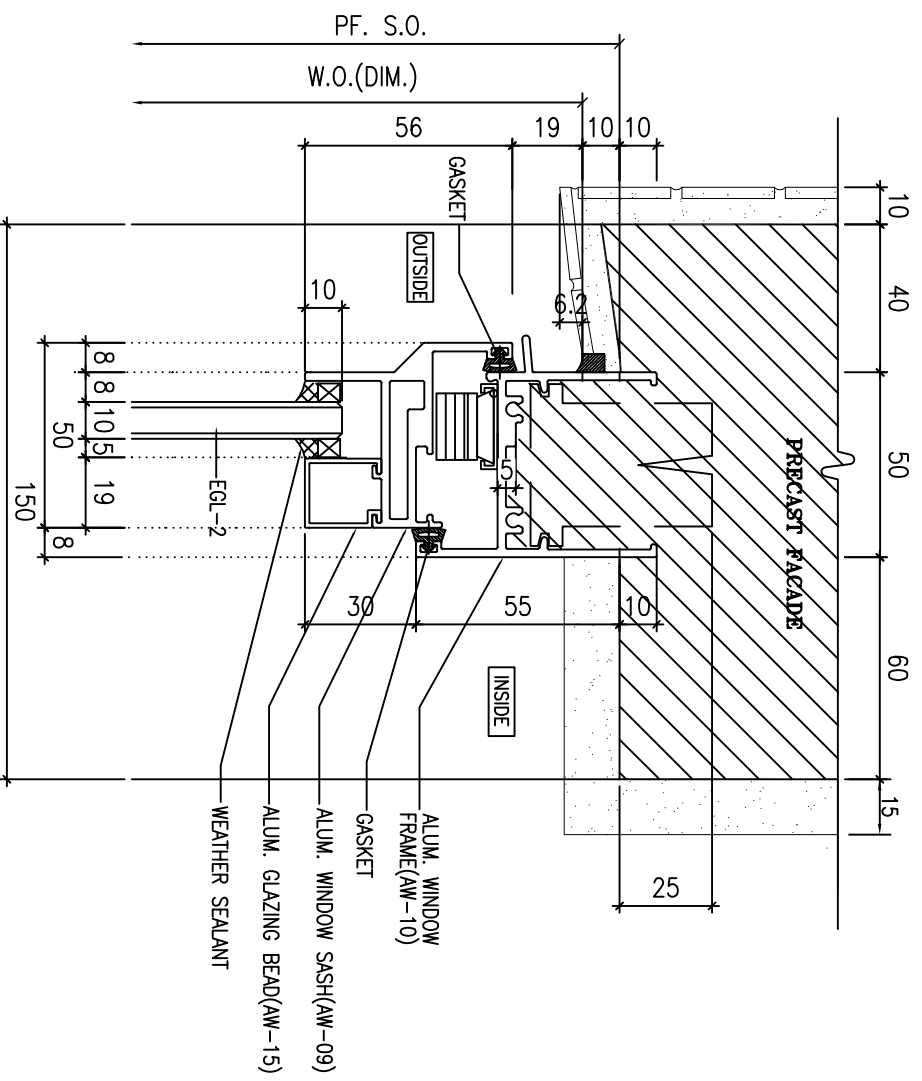

1 VERTICAL DETAIL
SCALE 1:2

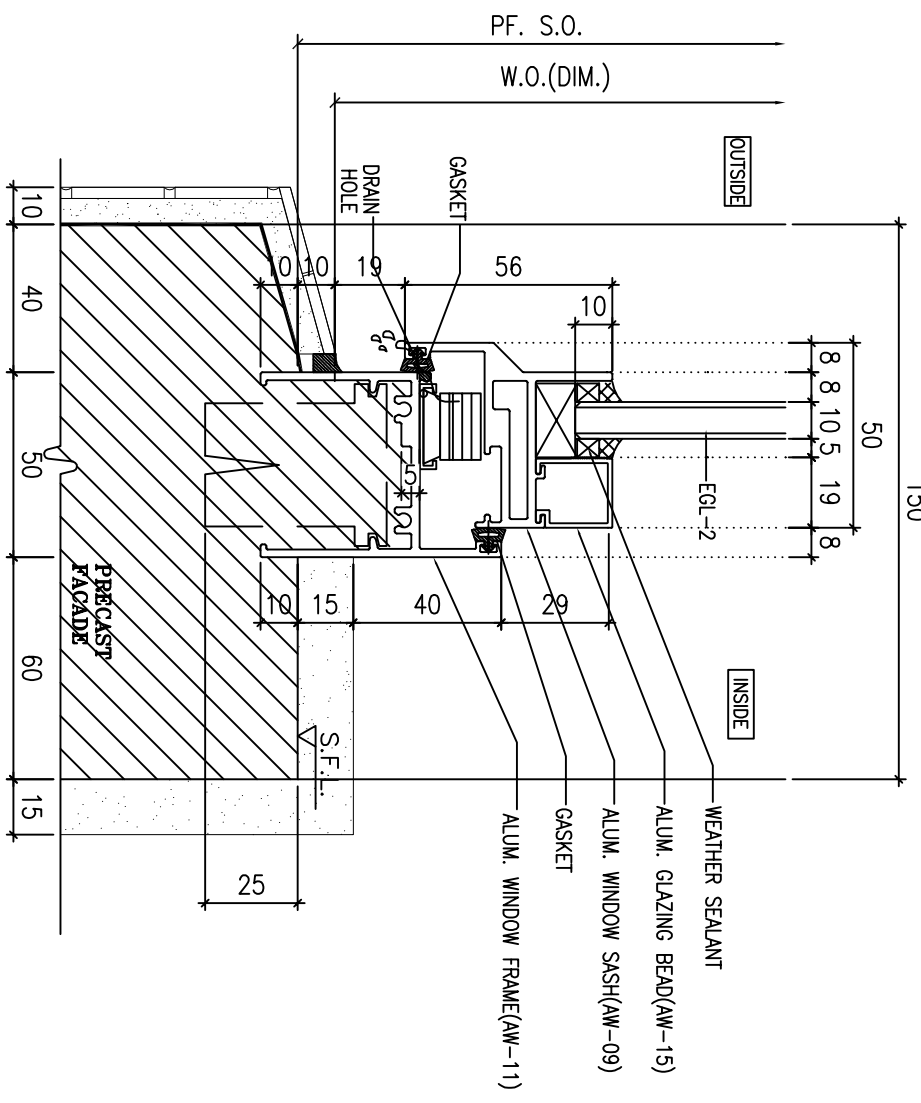

2 VERTICAL DETAIL
SCALE 1:2

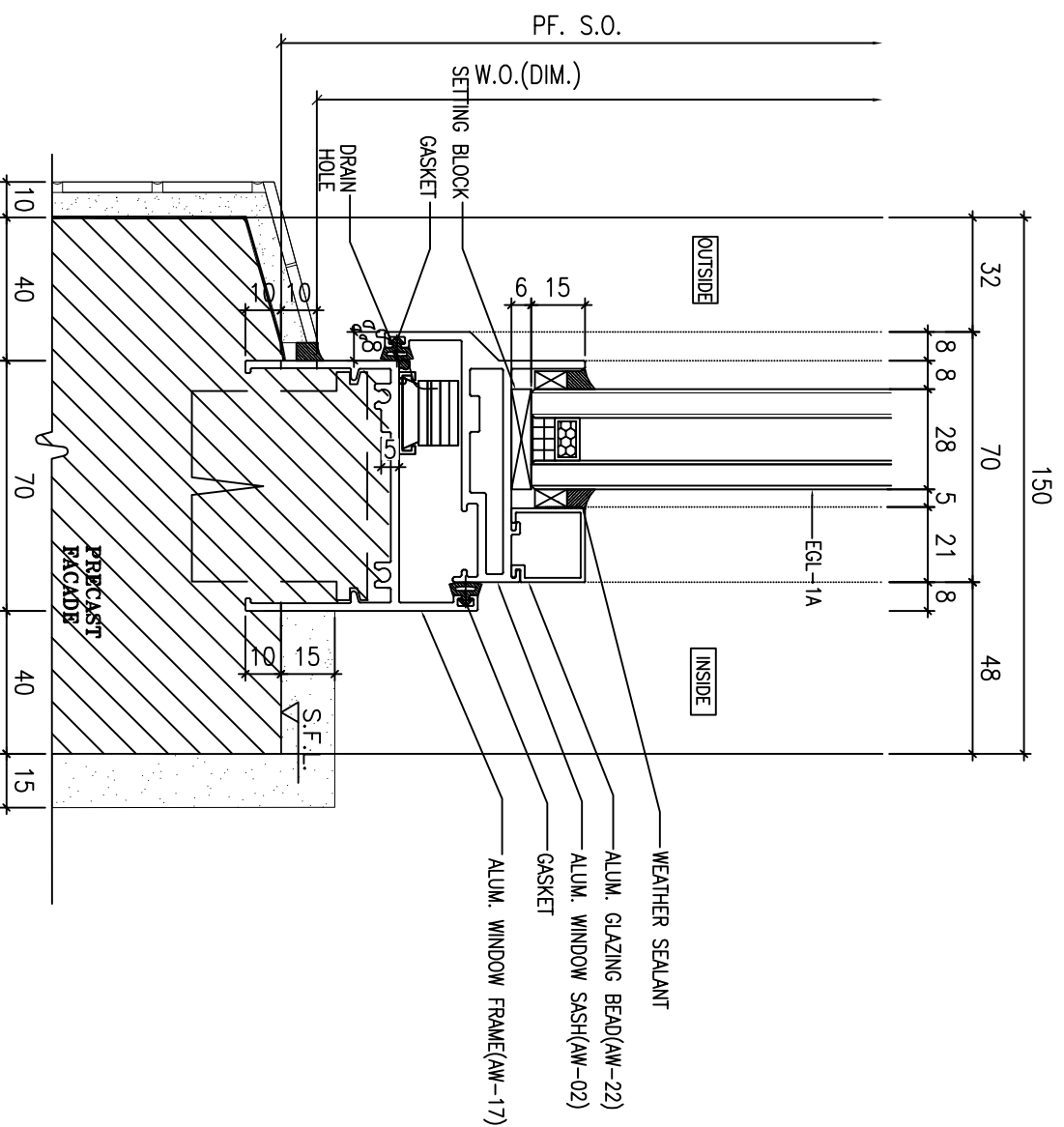

3 VERTICAL DETAIL
SCALE 1:2

B.D. REF :

CLIENT :

SUN HUNG KAI
REAL ESTATE AGENCY LTD.
42/F SUN HUNG KAI CENTRE, WANCHAI, HONGKONG

ARCHITECT :

lwk&partners
a r c h i t e c t s

MANU CONTRACTOR :

ARUP
ALPHA CONSULTING LIMITED
Steel Structure & Façade Specialist

STRUCTURAL ENGINEER :

NOTE :

1. ALL DIMENSIONS ARE IN mm.
2. ALL ELEVATIONS ARE VIEWED FROM OUTSIDE.
3. ALL DIMENSIONS TO BE VERIFIED ON SITE BEFORE FABRICATION.

LEGEND :

- (X1) DETAIL MARK NO.
- (X001) REFER SHEET NO.
- 1. F.F.L. --- FINISHED FLOOR LEVEL
- 2. S.F.L. --- STRUCTURAL FLOOR LEVEL
- 3. (R) --- REVERSED DETAIL
- 4. GLASS LEGEND

EQ-1--8mmH5+12mm AIR GAP+10mmTP THK. I.G.U.
EQ-2--10mm THK. CLEAR TEMPERED GLASS
EQ-4--10mm THK. TEMPERED ACID ETCHED GLASS
EQ-1A--8mmH5+12mm AIR GAP+8mmTP THK. I.G.U.

NO.	DATE	REVISION	BY
C	25/09/2022	REVISION SUBJECT TO ARCH/COMMENT	HW
B	02/11/2021	REVISION SUBJECT TO ARCH/COMMENT	HW
A	30/10/2021	REVISION SUBJECT TO ARCH/COMMENT	HW

JOB NO. : J-856
PROJECT : PROPOSED DEVELOPMENT ABOVE LIGHT RAIL TIN WING STOP-TSWTL NO.23, AREA 33, TIN SHUI WAI, N.T.

TITLE : TYPICAL DETAILS FOR ALUM. WINDOW

DATE : 02-Aug-21 SCALE : 1:40
DRAWN BY : IYVN CHECKED BY :

美特铝质有限公司
MIDI ALUMINUM FABRICATOR LTD.
Units 6-8, Sunny Industrial Centre, 1/F
610 Cho Kwong Road, Kowloon
Tel: 23489211-4 Fax: (852) 27272666
DWG NO. : J856-SD-PW-D171 REV. : C

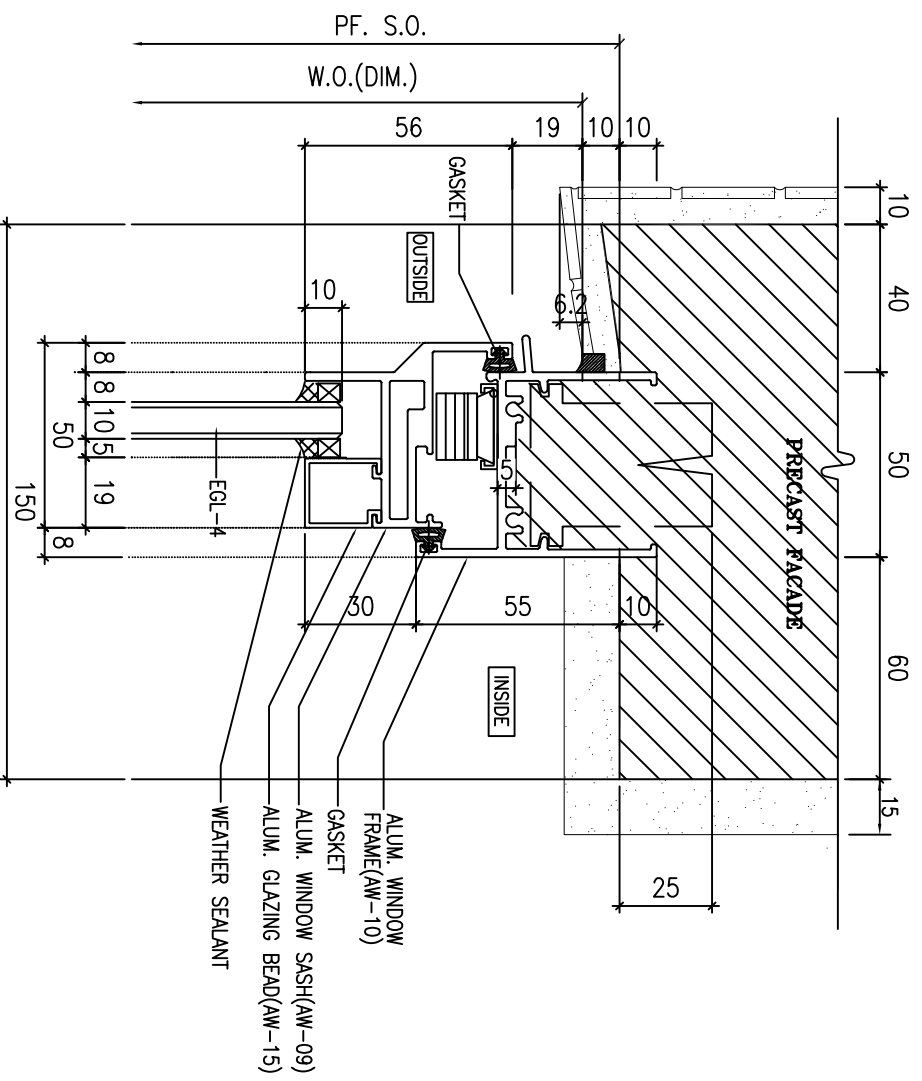

1 VERTICAL DETAIL
SCALE 1:2

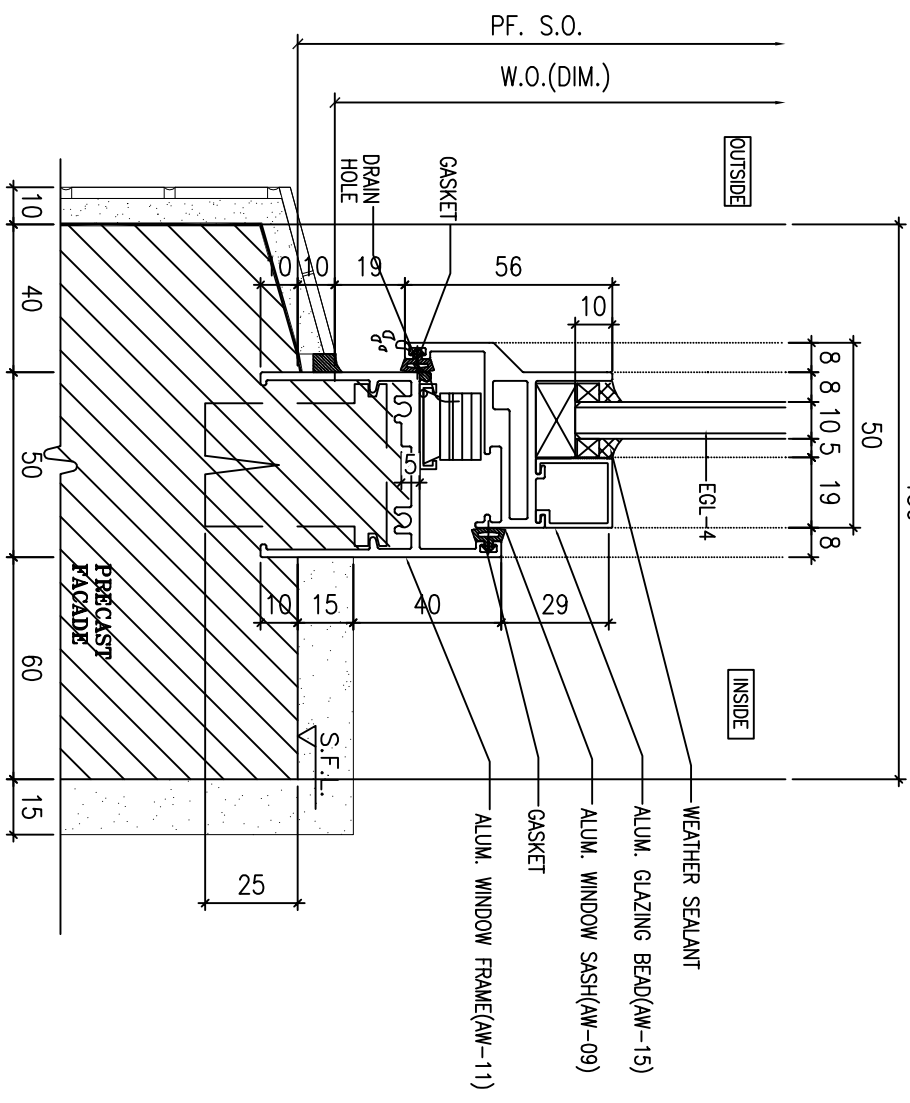

2 VERTICAL DETAIL
SCALE 1:2

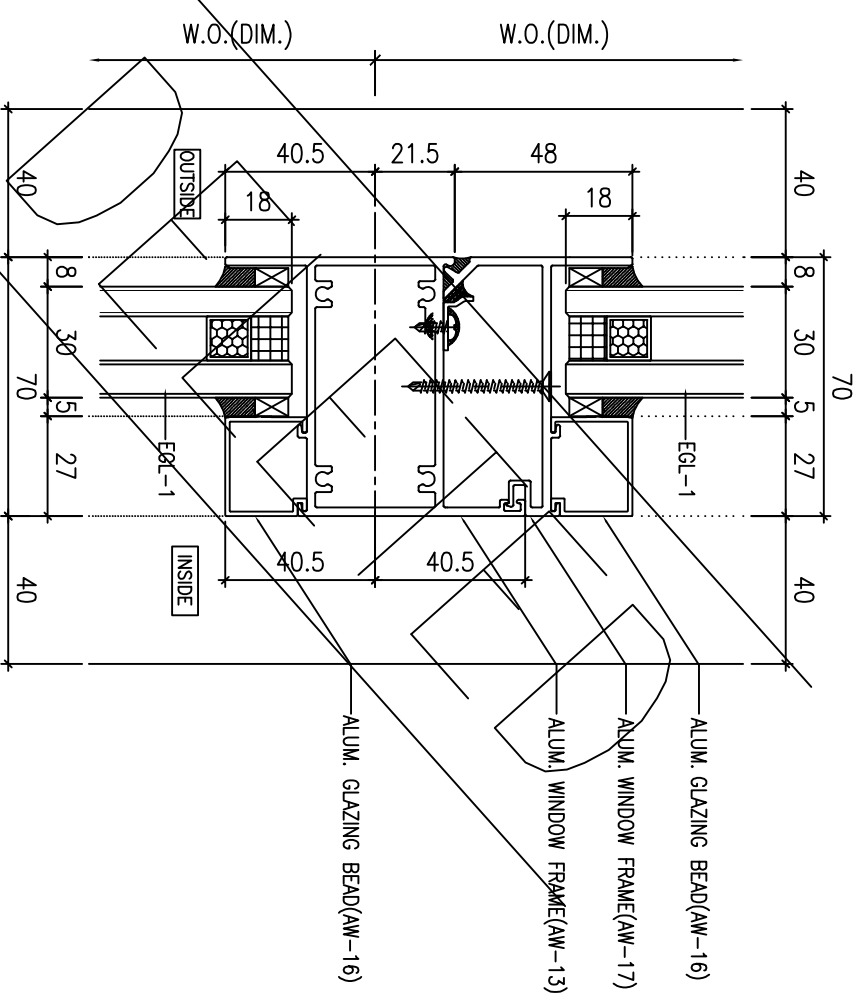

3 VERTICAL DETAIL
SCALE 1:2

B.D. REF :

CLIENT :

SUN HUNG KAI
REAL ESTATE AGENCY LTD.
42/F SUN HUNG KAI CENTRE, WANCHAI, HONGKONG

ARCHITECT :

lwk&partners
ARCHITECTS

MAIN CONTRACTOR :

ARUP
ALPHA CONSULTING LIMITED
Steel Structure & Façade Specialist

STRUCTURAL ENGINEER :

FAÇADE CONSULTANT :

NOTE :

1. ALL DIMENSIONS ARE IN mm.
2. ALL ELEVATIONS ARE VIEWED FROM OUTSIDE.
3. ALL DIMENSIONS TO BE VERIFIED ON SITE BEFORE FABRICATION.

LEGEND :

(X1)	DETAIL MARK NO.
(X001)	REFER SHEET NO.
1.	F.F.L. --- FINISHED FLOOR LEVEL
2.	S.F.L. --- STRUCTURAL FLOOR LEVEL
3.	(R) --- REVERSED DETAIL
4.	GLASS LEGEND
EQL-1	--8mmH+12mm AIR GAP+10mmTP THK. I.G.U.
EQL-2	--10mm THK. CLEAR TEMPERED GLASS
EQL-4	--10mm THK. TEMPERED ACID ETCHED GLASS
EQL-1A	--8mmH+12mm AIR GAP+8mmTP THK. I.G.U.

JOB NO. : J-856

PROJECT : PROPOSED DEVELOPMENT ABOVE LIGHT RAIL TIN WING STOP-TSWTL NO.23, AREA 33, TIN SHUI WAI, N.T.

TITLE : TYPICAL DETAILS FOR ALUM. WINDOW

DATE : 02-Aug-21 SCALE : 1:40

DRAWN BY : IYON CHECKED BY :

美特铝质有限公司
MIDI ALUMINUM FABRICATOR LTD.
Units 6-8, Sunny Industrial Centre, 1/F
610 Cho Kwong Road, Kwailoon
Tel: 23489211-4 Fax: (852) 27272666

DWG NO. : J856-SD-PW-DT71a REV. : C

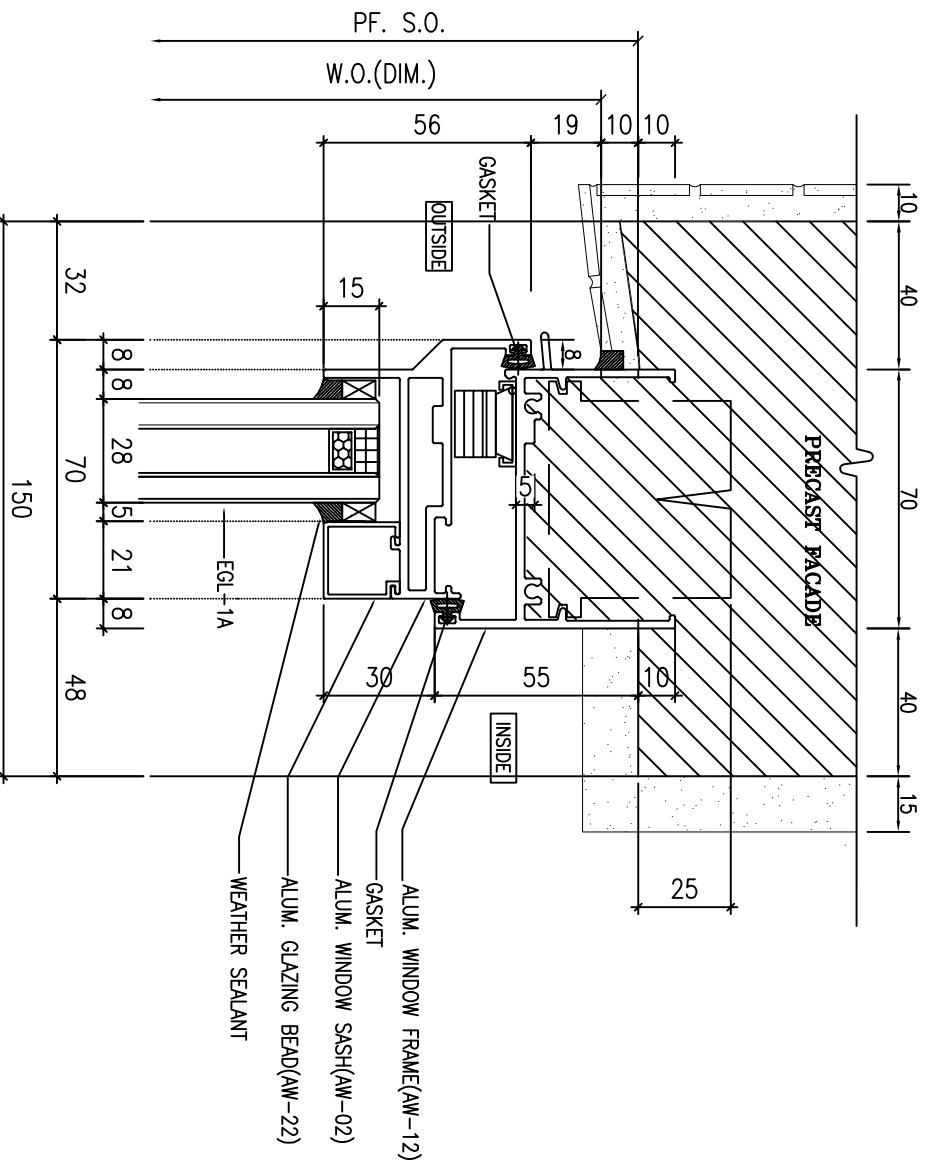

1 VERTICAL DETAIL
SCALE 1:2

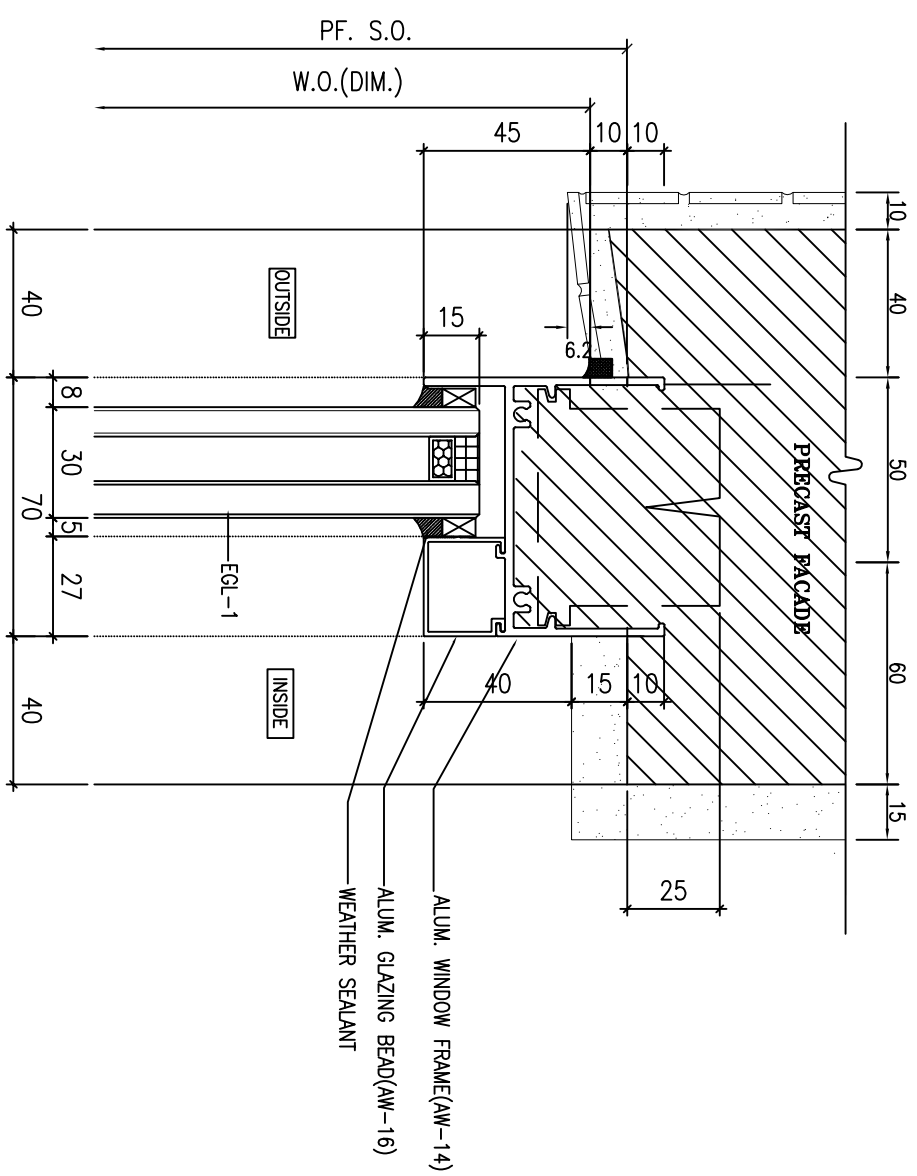

3 VERTICAL DETAIL
SCALE 1:2

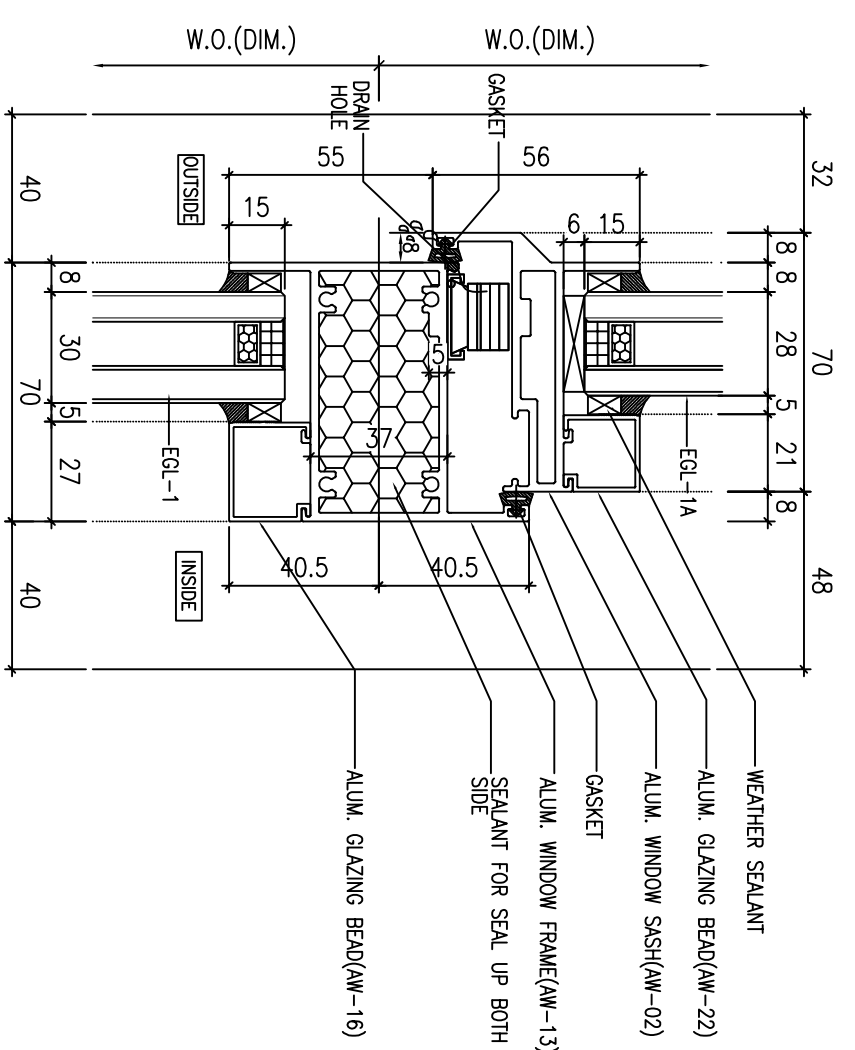

2 VERTICAL DETAIL
SCALE 1:2

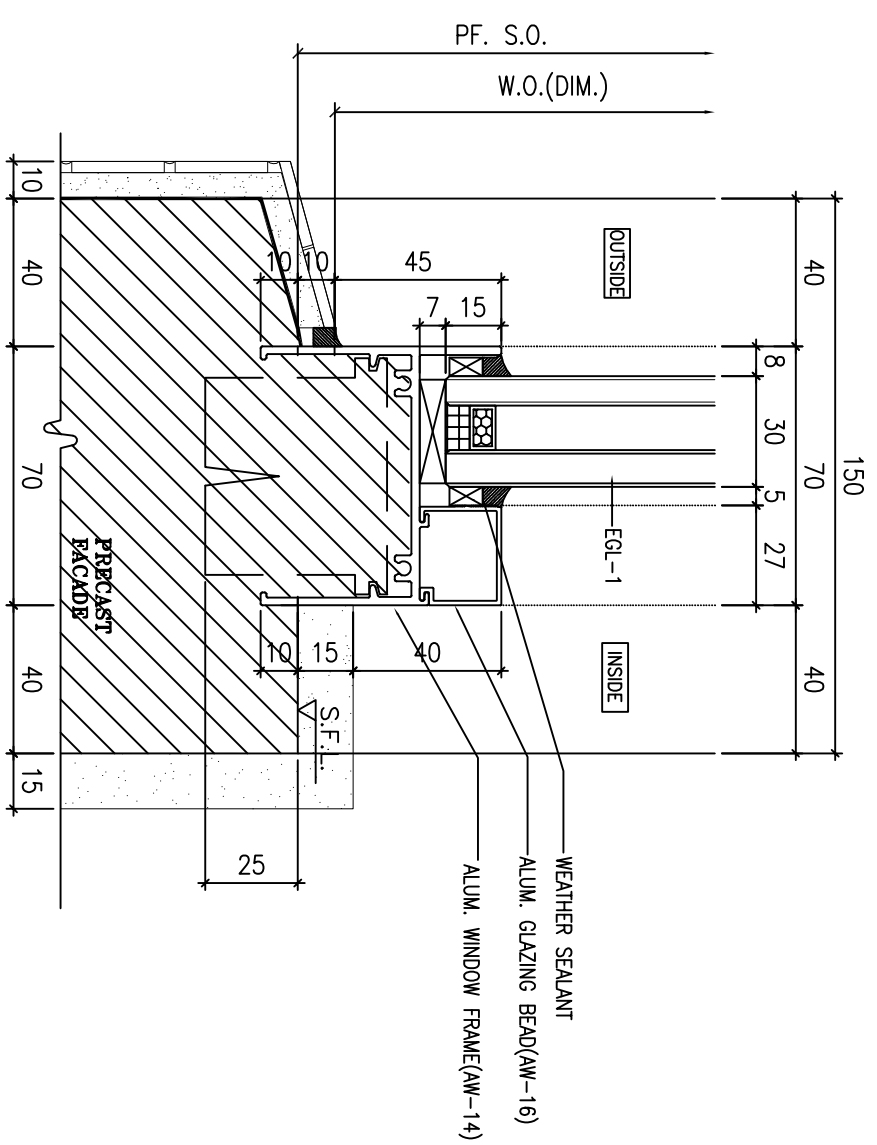

4 VERTICAL DETAIL
SCALE 1:2

B.D. REF :

CLIENT :

SUN HUNG KAI
REAL ESTATE AGENCY LTD.
42/F SUN HUNG KAI CENTRE, WANCHAI, HONGKONG

ARCHITECT :

lwk&partners
ARCHITECTS

MAIN CONTRACTOR :

ARUP
ALPHA CONSULTING LIMITED
Steel Structure & Façade Specialist

STRUCTURAL ENGINEER :

ARUP
ALPHA CONSULTING LIMITED
Steel Structure & Façade Specialist

NOTE :

1. ALL DIMENSIONS ARE IN mm.
2. ALL ELEVATIONS ARE VIEWED FROM OUTSIDE.
3. ALL DIMENSIONS TO BE VERIFIED ON SITE BEFORE FABRICATION.

LEGEND :

- (X1) --- DETAIL MARK NO.
- (X001) --- REFER SHEET NO.

PROJECT :

PROPOSED DEVELOPMENT ABOVE
LIGHT RAIL TIN WING STOP TSWTL
NO.23, AREA 33, TIN SHUI WAI, N.T.

TITLE :

TYPICAL DETAILS FOR
ALUM. WINDOW

DATE : 02-Aug-21 SCALE : 1:40

DRAWN BY : IYON CHECKED BY :

UNIT 6-8, SUNNY INDUSTRIAL CENTRE, 1/F
610 CHO KWO LING ROAD, KOWLOON
TEL: 23492111-4 FAX: (852) 27272666
DWG NO. : J856-SD-PW-D172 REV : C

美特铝质有限公司
MIDI ALUMINUM FABRICATOR LTD.
Units 6-8, Sunny Industrial Centre, 1/F
610 Cho Kwo Ling Road, Kowloon
Tel: 23492111-4 Fax: (852) 27272666

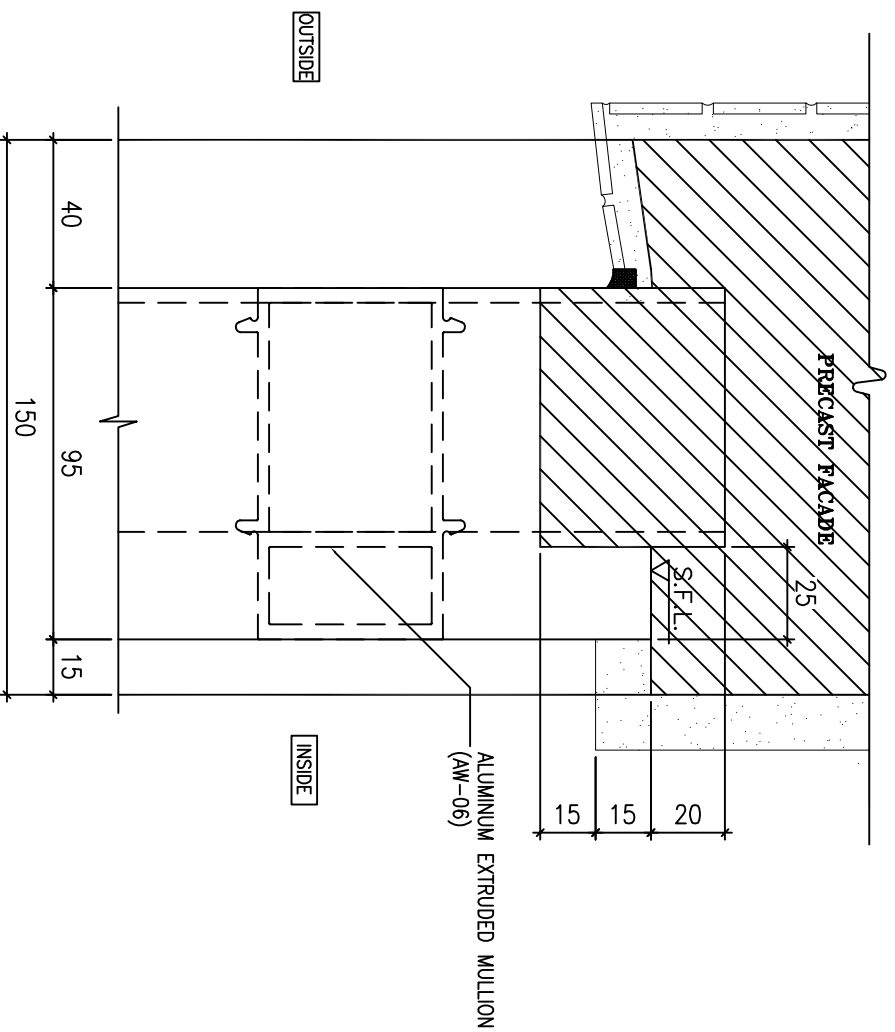

1 VERTICAL DETAIL
SCALE 1:2

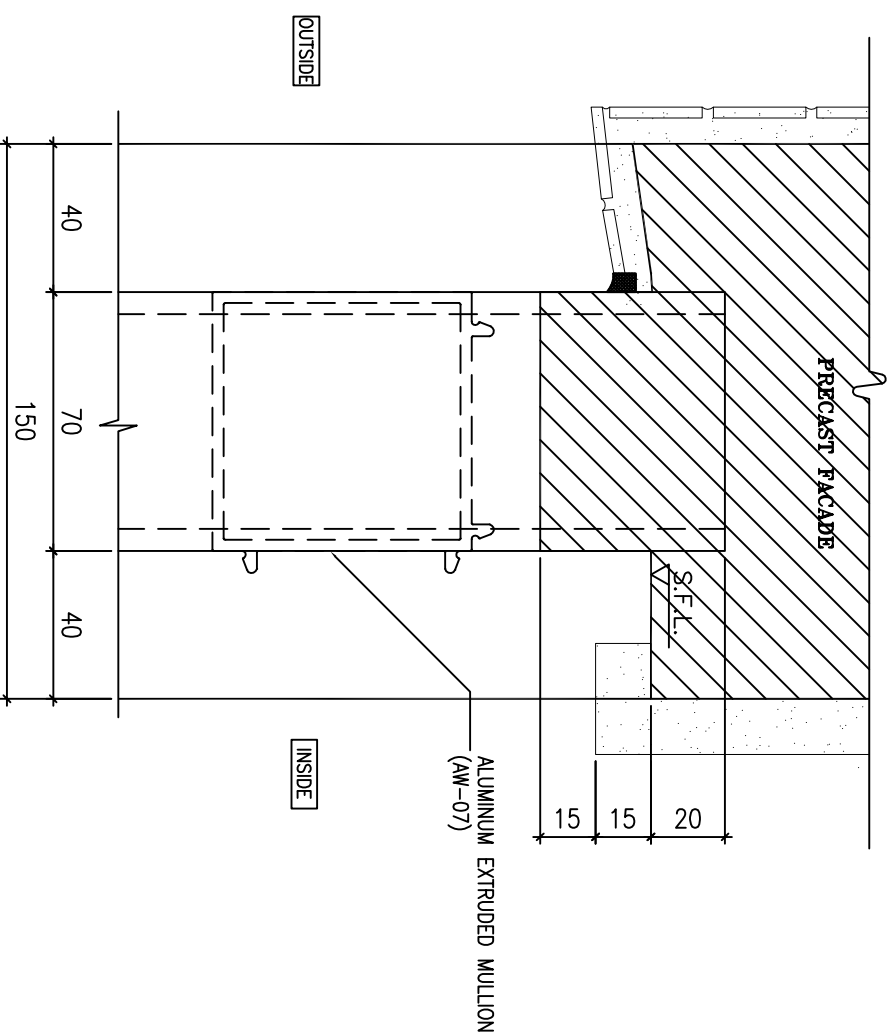

3 VERTICAL DETAIL
SCALE 1:2

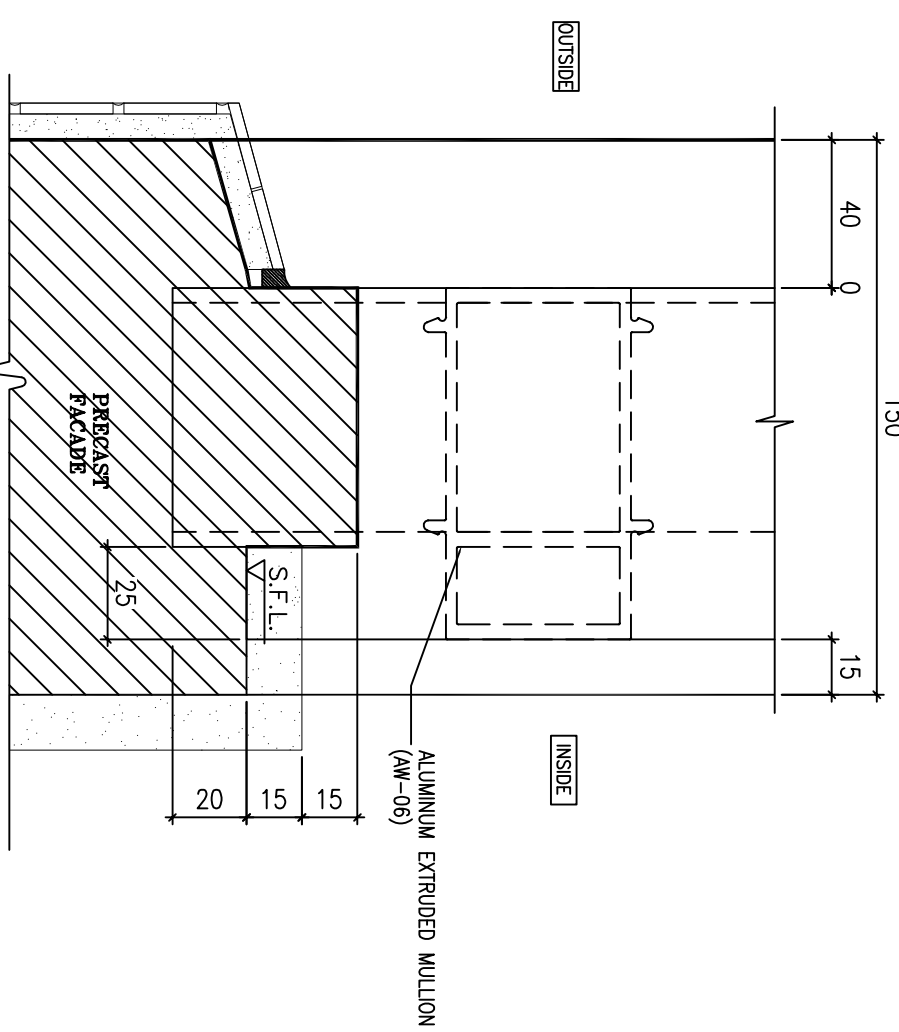

2 VERTICAL DETAIL
SCALE 1:2

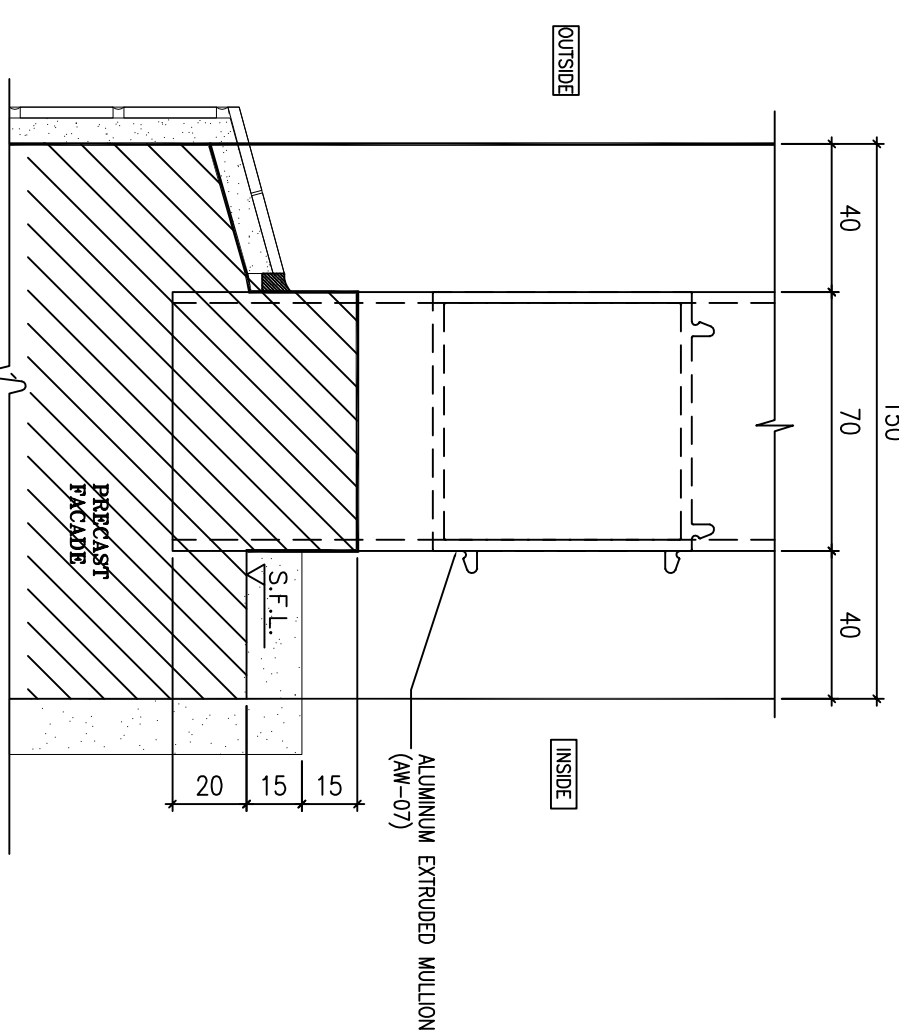

4 VERTICAL DETAIL
SCALE 1:2

B.D. REF :

CLIENT :

SUN HUNG KAI
REAL ESTATE AGENCY LTD.
42/F SUN HUNG KAI CENTRE, WANCHAI, HONGKONG

ARCHITECT :

lwk&partners
a r c h i t e c t s

MAIN CONTRACTOR :

怡輝建築有限公司
Yee Fai Building Contractors Ltd.

STRUCTURAL ENGINEER :

ARUP

FAÇADE CONSULTANT :

ALPHA CONSULTING LIMITED
Steel Structure & Façade Specialist

NOTE :

1. ALL DIMENSIONS ARE IN mm.
2. ALL ELEVATIONS ARE VIEWED FROM OUTSIDE.
3. ALL DIMENSIONS TO BE VERIFIED ON SITE BEFORE FABRICATION.

LEGEND :

- (X1) DETAIL MARK NO.
- (X001) REFER SHEET NO.

1. F.F.L. --- FINISHED FLOOR LEVEL
2. S.F.L. --- STRUCTURAL FLOOR LEVEL
3. (R) --- REVERSED DETAIL

4. GLASS LEGEND
- EQ.-1 --- 8mmH5+12mm AIR GAP+10mmTP THK. I.G.U.
- EQ.-2 --- 10mm THK. CLEAR TEMPERED GLASS
- EQ.-4 --- 10mm THK. TEMPERED ACID ETCHED GLASS
- EQ.-1A --- 8mmH5+12mm AIR GAP+8mmTP THK. I.G.U.

NO.	DATE	REVISION	BY
C	02/11/2021	REVISION SUBJECT TO ARCH/COMMENT	ivan
B	30/10/2021	REVISION SUBJECT TO ARCH/COMMENT	ivan
A	30/09/2021	REVISION SUBJECT TO ARCH/COMMENT	ivan

JOB NO. : J-856

PROJECT :
PROPOSED DEVELOPMENT ABOVE
LIGHT RAIL TIN WING STOP TSWTL
NO.23, AREA 33, TIN SHUI WAI, N.T.

TITLE :
TYPICAL DETAILS FOR
ALUM. WINDOW

DATE : 02-Aug-21 SCALE : 1:40

DRAWN BY : ivan CHECKED BY :

美特鋁質有限公司
MIDI ALUMINUM FABRICATOR LTD.
Units 6-8, Sunny Industrial Centre, 1/F
610 Cho Kwong Road, Kwailoon
Tel:23489211-4 Fax:(852)27272666

DWG NO. : J856-SD-PW-D173 REV. : C

CLIENT :

SUN HUNG KAI
 REAL ESTATE AGENCY LTD.
 42/F SUN HUNG KAI CENTRE, WANCHAI, HONGKONG

ARCHITECT :

lwk&partners
 a r c h i t e c t s

MAIN CONTRACTOR :

怡輝建築有限公司
Yee Fai Building Contractors Ltd.

STRUCTURAL ENGINEER :

ARUP

FAÇADE CONSULTANT:

ALPHA CONSULTING LIMITED
 Steel Structure & Façade Specialist

NOTE :

1. ALL DIMENSIONS ARE IN mm.
2. ALL ELEVATIONS ARE VIEWED FROM OUTSIDE.
3. ALL DIMENSIONS TO BE VERIFIED ON SITE BEFORE FABRICATION.

LEGEND :

- (X1) --- DETAIL MARK NO.
- (X001) --- REFER SHEET NO.

1. F.F.L. --- FINISHED FLOOR LEVEL
2. S.F.L. --- STRUCTURAL FLOOR LEVEL
3. (R) --- REVERSED DETAIL

4. GLASS LEGEND
- EQ-1 --- 8mmH5+12mm AIR GAP+10mmTP THK. I.G.U.
- EQ-2 --- 10mm THK. CLEAR TEMPERED GLASS
- EQ-4 --- 10mm THK. TEMPERED ACID ETCHED GLASS
- EQ-1A --- 8mmH5+12mm AIR GAP+8mmTP THK. I.G.U.

NO.	DATE	REVISION	BY

JOB NO. : J-856

PROJECT :
 PROPOSED DEVELOPMENT ABOVE
 LIGHT RAIL TIN WING STOP TSWTL
 NO.23, AREA 33, TIN SHUI WAI, N.T.

TITLE :
 ALUM. WINDOW SECTION
 TYPICAL LOCK & HINGERS DETAIL

DATE : 02-Aug-21 SCALE : 1:40

DRAWN BY : IYON CHECKED BY :

美特鋁質有限公司
MIDI ALUMINUM FABRICATOR LTD.
 Units 6-8, Sunray Industrial Centre, 1/F
 610 Cho Kwo Ling Road, Kowloon
 Tel:23489211-4 Fax:(852)2727666
 DWG NO. : J856-SD-PW-D174 REV. : -

70窗

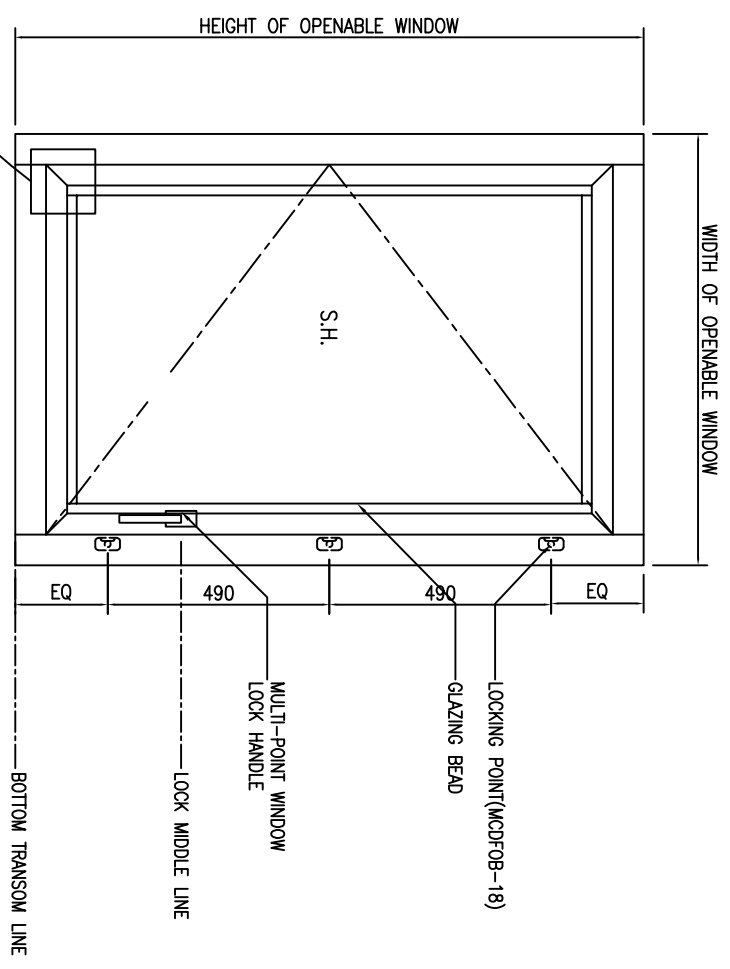
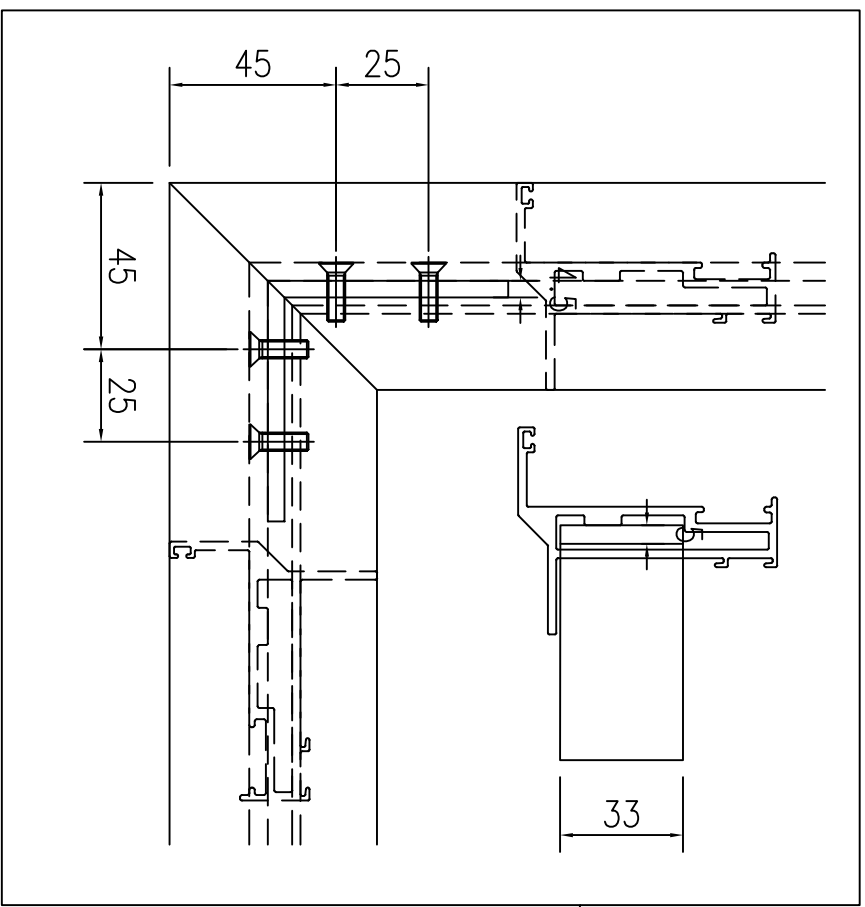

01 TYPICAL SECTION

S.F.L.

B.D. REF :

CLIENT :

SUN HUNG KAI
REAL ESTATE AGENCY LTD.
42/F SUN HUNG KAI CENTRE, WANCHAI, HONGKONG

ARCHITECT :

lwk&partners
a r c h i t e c t s

MAIN CONTRACTOR :

Yee Fai 怡輝建築有限公司
Building Contractors Ltd.

STRUCTURAL ENGINEER :

ARUP

FAÇADE CONSULTANT:

ALPHA CONSULTING LIMITED
Steel Structure & Façade Specialist

NOTE :

1. ALL DIMENSIONS ARE IN mm.
2. ALL ELEVATIONS ARE VIEWED FROM OUTSIDE.
3. ALL DIMENSIONS TO BE VERIFIED ON SITE BEFORE FABRICATION.

LEGEND :

X1 --- DETAIL MARK NO.
X001 --- REFER SHEET NO.

1. F.F.L. --- FINISHED FLOOR LEVEL
2. S.F.L. --- STRUCTURAL FLOOR LEVEL
3. (R) --- REVERSED DETAIL

4. GLASS LEGEND
EQ-1---8mmH5+12mm AIR GAP+10mmTP THK. I.G.U.
EQ-2---10mm THK. CLEAR TEMPERED GLASS
EQ-4---10mm THK. TEMPERED ACID ETCHED GLASS
EQ-1A---8mmH5+12mm AIR GAP+8mmTP THK. I.G.U.

NO.	DATE	REVISION	BY

JOB NO. : J-856

PROJECT :
PROPOSED DEVELOPMENT ABOVE
LIGHT RAIL TIN WING STOP TSWTL
NO.23,AREA 33,TIN SHUI WAI, N.T.

TITLE :
ALUM. WINDOW SECTION
TYPICAL LOCK & HINGERS DETAIL

DATE : 02-Aug-21 SCALE : 1:40

DRAWN BY : IYON CHECKED BY :

美特鋁質有限公司
MIDI ALUMINUM FABRICATOR LTD.
Units 6-8, Sunray Industrial Centre, 1/F
610 Cho Kwo Ling Road, Kowloon
Tel:23489211-4 Fax:(852)2727666

DWG NO. : J856-SD-PW-D174d REV. : -

50窗

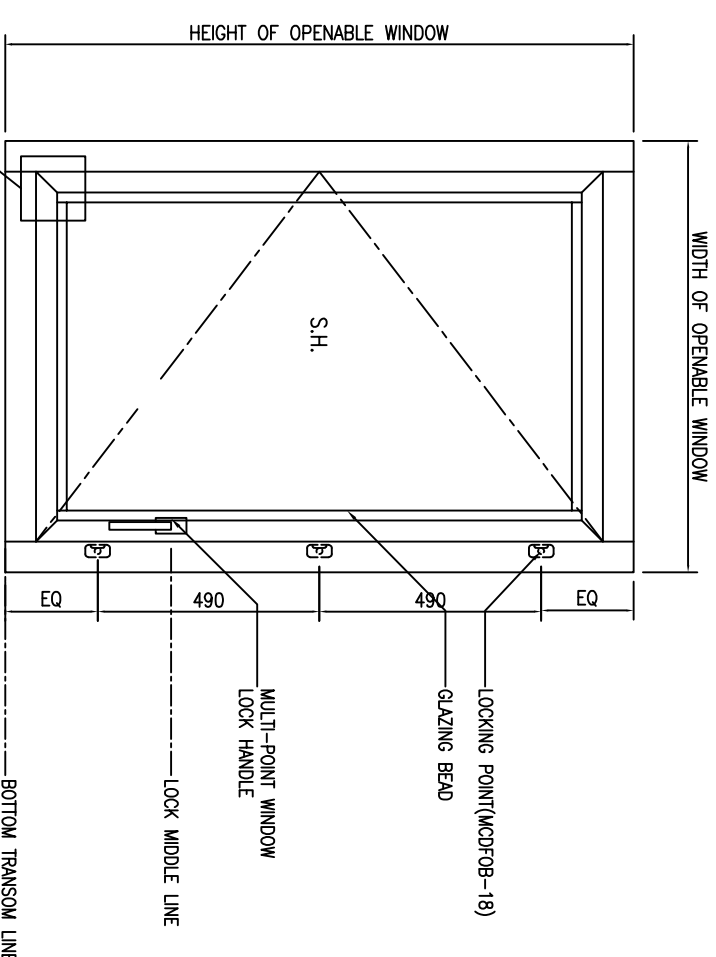
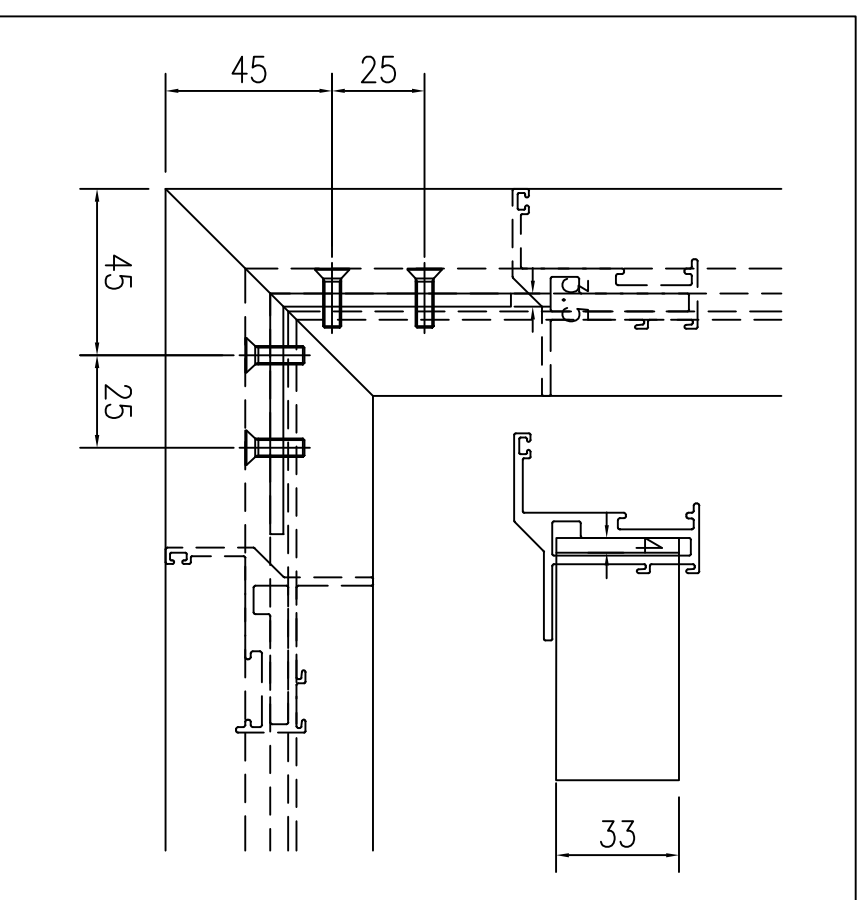

01 TYPICAL SECTION

S.F.L.

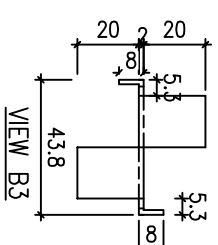
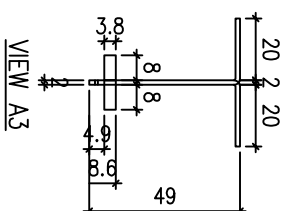
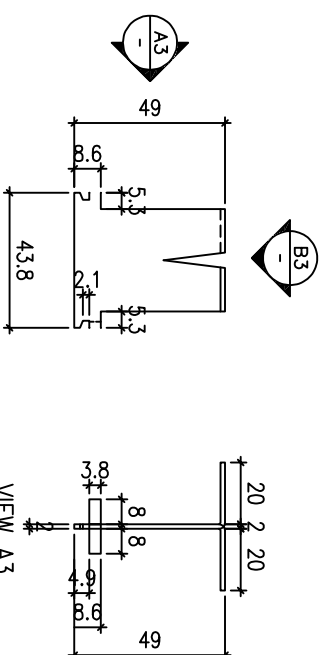
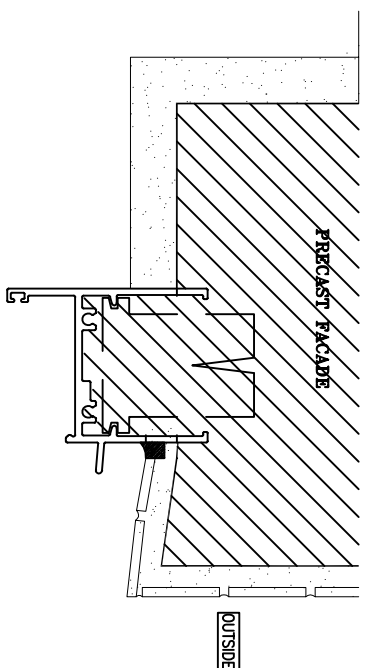
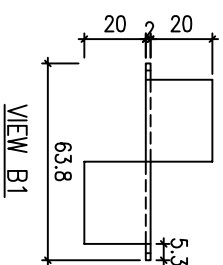
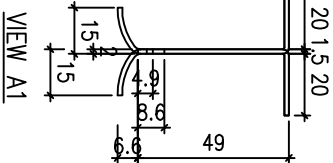
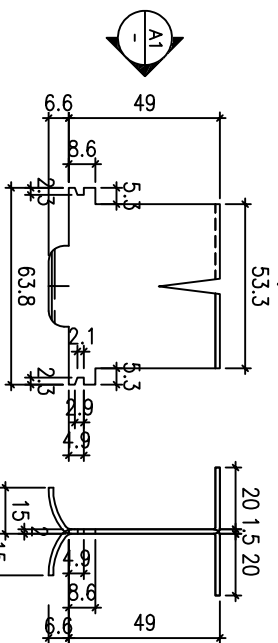
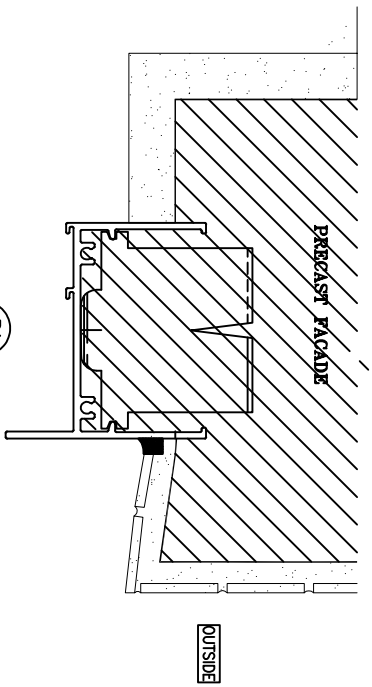

1 70 SECTION FIXING LUG
SCALE 1:2

3 50 SECTION FIXING LUG
SCALE 1:2

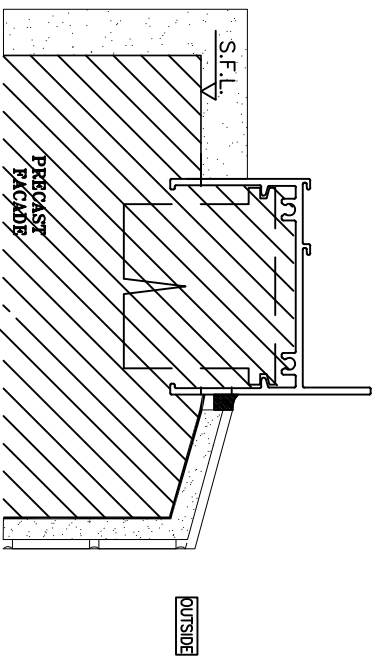
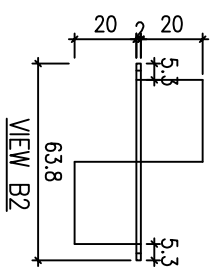
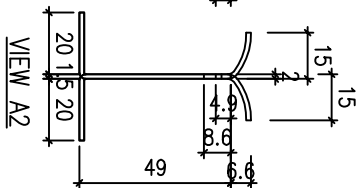
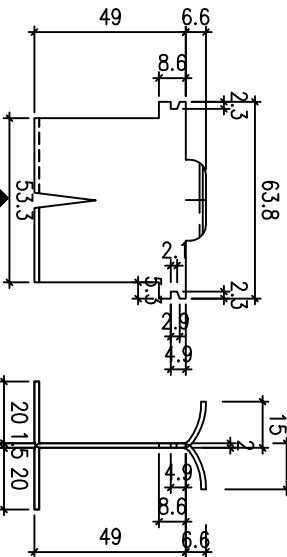
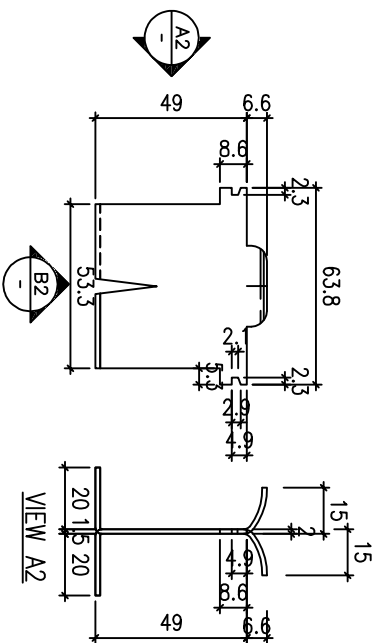

2 70 SECTION FIXING LUG
SCALE 1:2

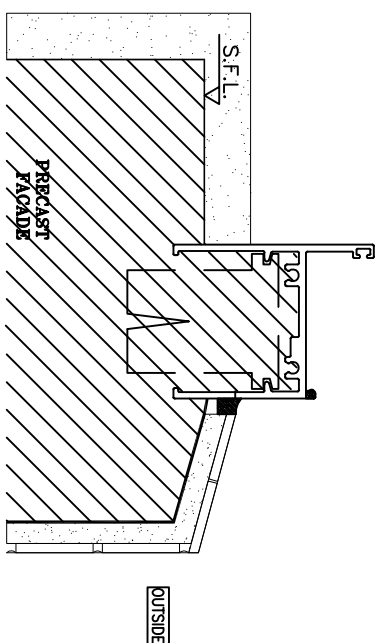

4 50 SECTION FIXING LUG
SCALE 1:2

B.D. REF :

CLIENT :

SUN HUNG KAI
REAL ESTATE AGENCY LTD.
42/F SUN HUNG KAI CENTRE, WANCHAI, HONGKONG

ARCHITECT :

lwk&partners
ARCHITECTS

MAIN CONTRACTOR :

Yee Fai 怡輝建築有限公司
Building Contractors Ltd.

STRUCTURAL ENGINEER :

ARUP

FAÇADE CONSULTANT :

α ALPHA CONSULTING LIMITED
Steel Structure & Façade Specialist

NOTE :

1. ALL DIMENSIONS ARE IN mm.
2. ALL ELEVATIONS ARE VIEWED FROM OUTSIDE.
3. ALL DIMENSIONS TO BE VERIFIED ON SITE BEFORE FABRICATION.

LEGEND :

(X1) --- DETAIL MARK NO.
(X001) --- REFER SHEET NO.

1. F.F.L. --- FINISHED FLOOR LEVEL
2. S.F.L. --- STRUCTURAL FLOOR LEVEL
3. (R) --- REVERSED DETAIL

4. GLASS LEGEND

- EQ-1 --- 8mmH+12mm AIR GAP+10mmTP THK. I.G.U.
- EQ-2 --- 10mm THK. CLEAR TEMPERED GLASS
- EQ-4 --- 10mm THK. TEMPERED ACID ETCHED GLASS
- EQ-1A --- 8mmH+12mm AIR GAP+8mmTP THK. I.G.U.

NO.	DATE	REVISION SUBJECT TO ARCH/COMMENT	BY
A	05/09/2022	REVISION SUBJECT TO ARCH/COMMENT	ivan

JOB NO. : J-856

PROJECT :
PROPOSED DEVELOPMENT ABOVE
LIGHT RAIL TIN WING STOP/TSWTL
NO.23,AREA 33,TIN SHUI WAI, N.T.

TITLE :
G.M.S FIXING LUG TYPICAL DETAIL
FOR ALUM. WINDOW

DATE : 02-Aug-21 SCALE : 1:60

DRAWN BY : ivan CHECKED BY :

美特鋁質有限公司
MIDI ALUMINUM FABRICATOR LTD.
Units 6-8, Sunray Industrial Centre, 1/F
610 Cho Kwo Ling Road, Kowloon
Tel:23489211-4 Fax:(852)2727666

DWG NO. : J856-SD-PW-D175 REV. : A

CLIENT :

SUN HUNG KAI
REAL ESTATE AGENCY LTD.
42/F SUN HUNG KAI CENTRE, WANCHAI, HONGKONG

ARCHITECT :

lwk&partners
a r c h i t e c t s

MAIN CONTRACTOR :

怡輝建築有限公司
Yee Fai Building Contractors Ltd.

STRUCTURAL ENGINEER :

ARUP

FAÇADE CONSULTANT:

ALPHA CONSULTING LIMITED
Steel Structure & Façade Specialist

NOTE:

1. ALL DIMENSIONS ARE IN mm.
2. ALL ELEVATIONS ARE VIEWED FROM OUTSIDE.
3. ALL DIMENSIONS TO BE VERIFIED ON SITE BEFORE FABRICATION.

LEGEND :

(X1) --- DETAIL MARK NO.
(X001) --- REFER SHEET NO.

1. F.F.L. --- FINISHED FLOOR LEVEL
2. S.F.L. --- STRUCTURAL FLOOR LEVEL
3. (R) --- REVERSED DETAIL
4. GLASS LEGEND

EQ-1 --- 8mmH5+12mm AIR GAP+10mmTP THK. I.G.U.
EQ-2 --- 10mm THK. CLEAR TEMPERED GLASS
EQ-4 --- 10mm THK. TEMPERED ACID ETCHED GLASS
EQ-1A --- 8mmH5+12mm AIR GAP+8mmTP THK. I.G.U.

NO.	DATE	REVISION	SUBJECT TO ARCH/COMMENT	BY
B	05/09/2022	REVISION SUBJECT TO ARCH/COMMENT		HW
A	03/07/2022	REVISION SUBJECT TO ARCH/COMMENT		HW

JOB NO. : J-856

PROJECT :

PROPOSED DEVELOPMENT ABOVE
LIGHT RAIL TIN WING STOP TSWTL
NO.23, AREA 33, TIN SHUI WAI, N.T.

TITLE :

TYPICAL EARTHING
BONDING DETAILS OF PRECAST

DATE : 02-Aug-21 SCALE : 1:40

DRAWN BY : IYON CHECKED BY :

美特鋁質有限公司
MIDI ALUMINUM FABRICATOR LTD.
Units 6-8, Sunray Industrial Centre, 1/F
610 Cho Kwo Ling Road, Kowloon
Tel: 23489211-4 Fax: (852) 27272666

DWG NO. : J856-SD-PW-D176 REV. : B

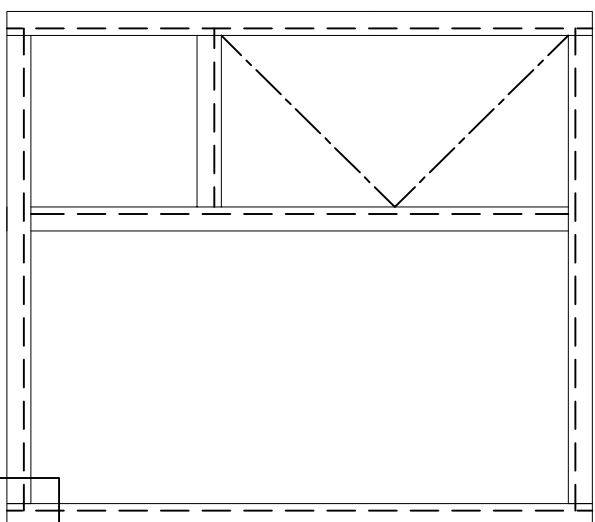

VIEW: C

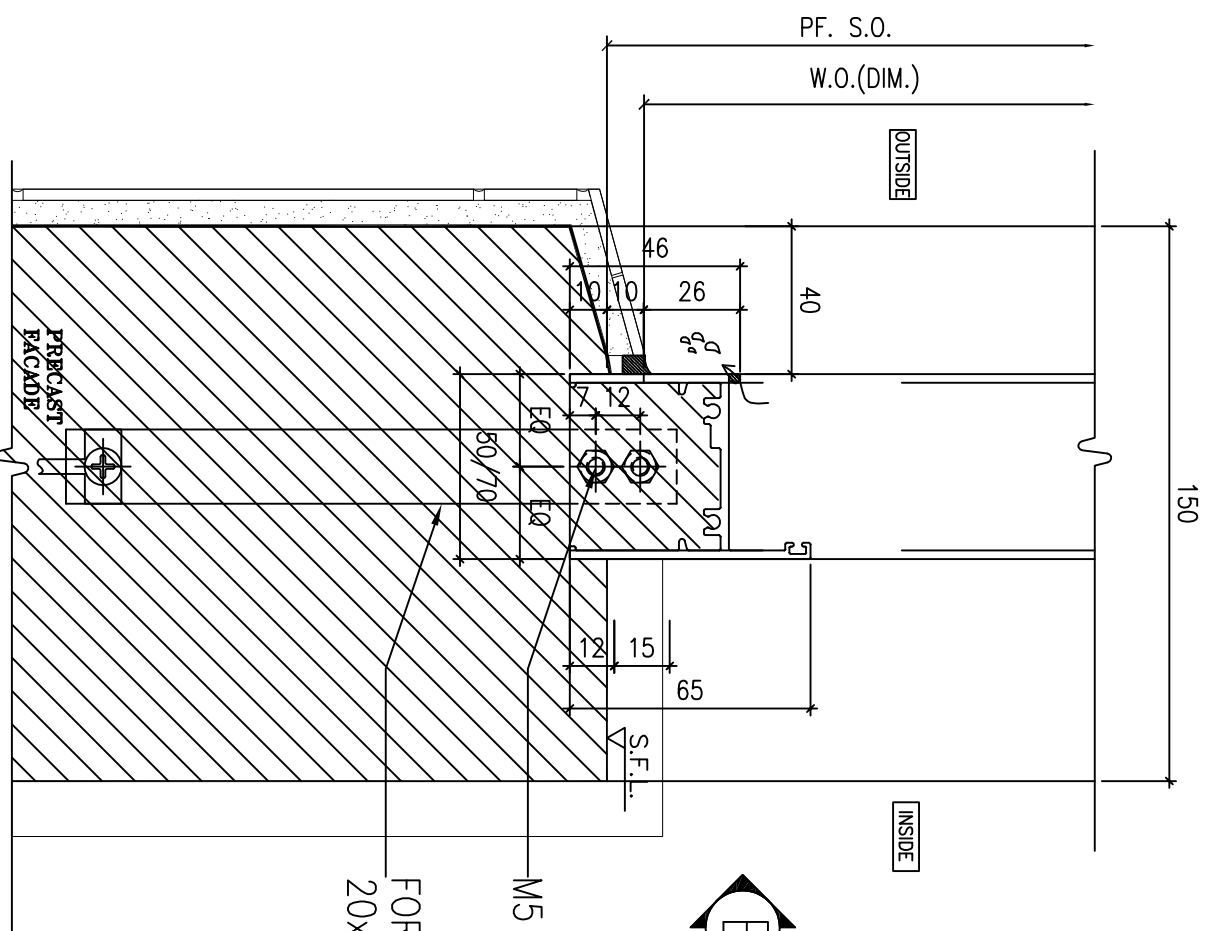

1 VERTICAL DETAIL

M5 S.S. SCREW
FOR EARTH BONDING
20x1.5mm THK. ALUM. BRACKET

M5 S.S. SCREW
FOR EARTH BONDING
20x1.5mm THK. ALUM. BRACKET

VIEW: C

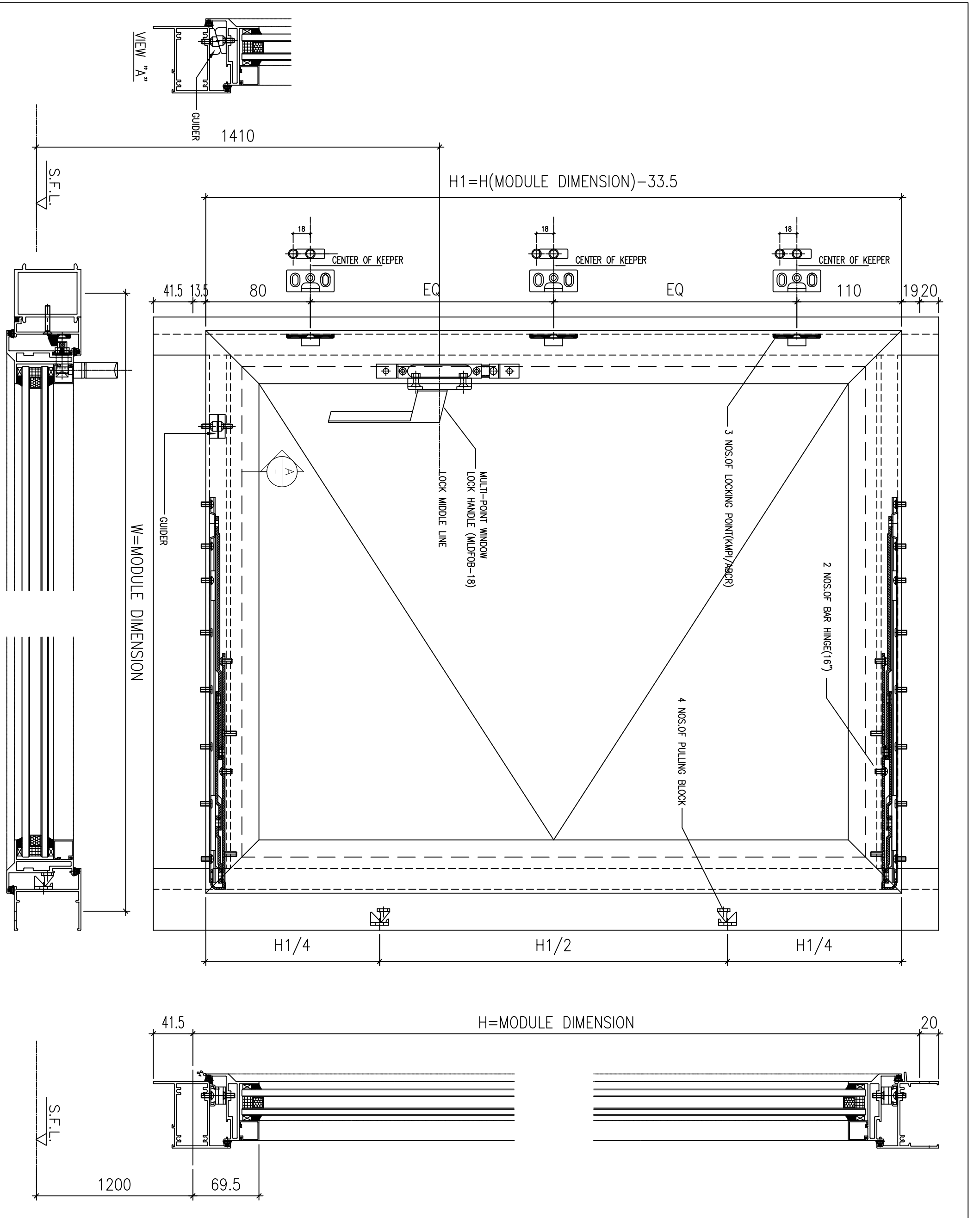

B.D. REF :

CLIENT :

SUN HUNG KAI
REAL ESTATE AGENCY LTD.
42/F SUN HUNG KAI CENTRE, WANCHAI, HONGKONG

ARCHITECT :

lwk&partners
a r c h i t e c t s

MAIN CONTRACTOR :

怡輝建築有限公司
Yee Fai
Building Contractors Ltd.

STRUCTURAL ENGINEER :

ARUP

FAÇADE CONSULTANT :

ALPHA CONSULTING LIMITED
Steel Structure & Façade Specialist

NOTE :

1. ALL DIMENSIONS ARE IN mm.
2. ALL ELEVATIONS ARE VIEWED FROM OUTSIDE.
3. ALL DIMENSIONS TO BE VERIFIED ON SITE BEFORE FABRICATION.

LEGEND :

- (X1) --- DETAIL MARK NO.
- (X001) --- REFER SHEET NO.

1. F.F.L. --- FINISHED FLOOR LEVEL
2. S.F.L. --- STRUCTURAL FLOOR LEVEL
3. (R) --- REVERSED DETAIL
4. GLASS LEGEND

EQ-1 --- 8mmH+12mm AIR GAP+10mmTP THK. I.G.U.
EQ-2 --- 10mm THK. CLEAR TEMPERED GLASS
EQ-4 --- 10mm THK. TEMPERED ACID ETCHED GLASS
EQ-1A --- 8mmH+12mm AIR GAP+8mmTP THK. I.G.U.

NO.	DATE	REVISION	BY
D	26/09/2022	REVISION SUBJECT TO ALPHA COMMENT	
C	05/09/2022	REVISION SUBJECT TO ALPHA COMMENT	
B	06/07/2022	REVISION SUBJECT TO ALPHA COMMENT	
A	03/07/2022	REVISION SUBJECT TO ARCH COMMENT	

JOB NO. : J-856

PROJECT :
PROPOSED DEVELOPMENT ABOVE
LIGHT RAIL TIN WING STOP TSWTL
NO.23, AREA 33, TIN SHUI WAI, N.T.

TITLE :

TYPICAL EARTHING
BONDING DETAILS OF PRECAST

DATE : 02-Aug-21 SCALE : 1:60

DRAWN BY : IYON CHECKED BY :

美特鋁質有限公司
MIDI ALUMINUM FABRICATOR LTD.
Units 6-8, Sunny Industrial Centre, 1/F
610 Cho Kwo Ling Road, Kowloon
Tel: 23489211-4 Fax: (852) 2727666
DWG NO. : J856-SD-PW-D177 REV. : D

B.D. REF :

W=MODULE DIMENSION

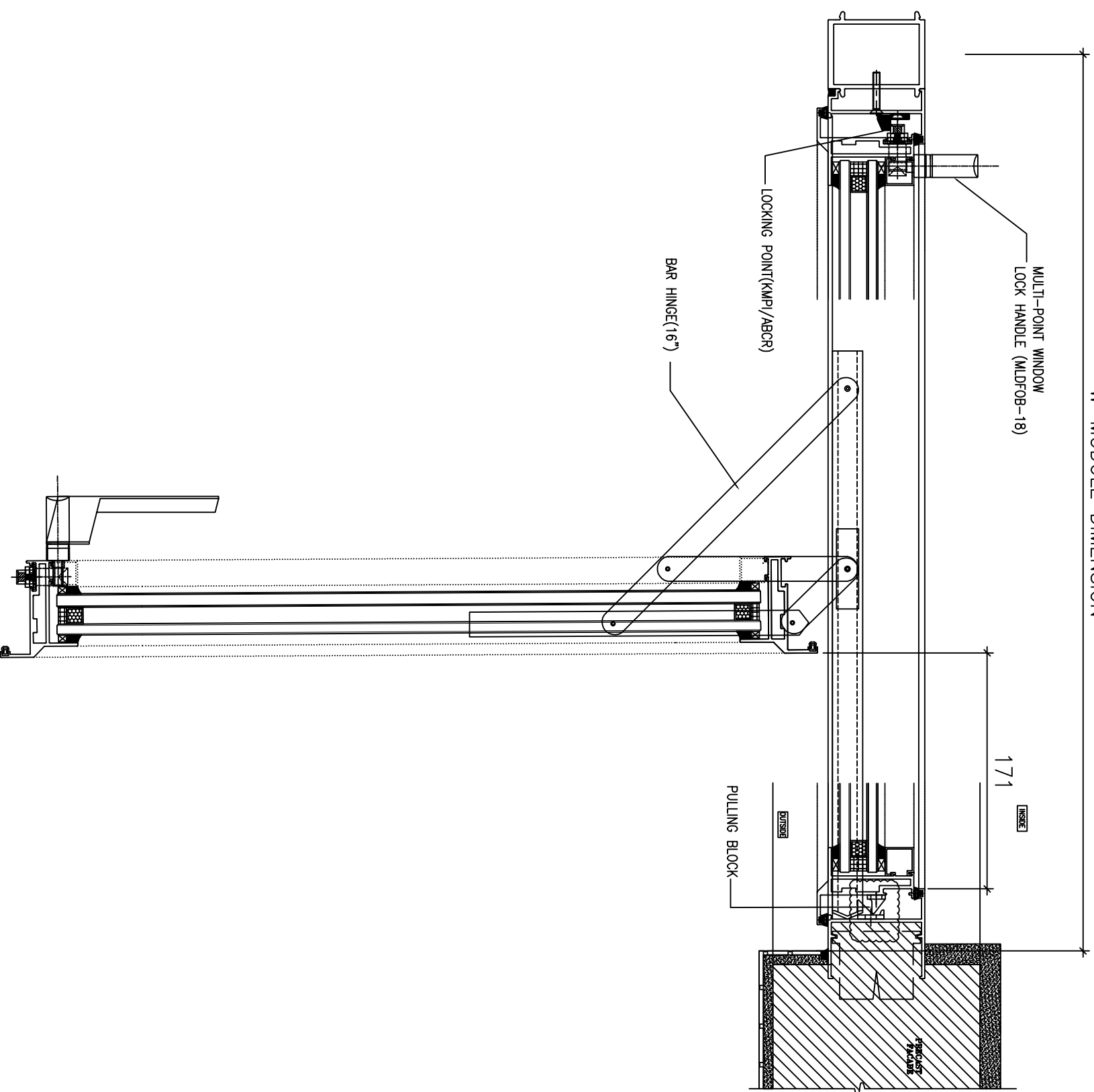

CLIENT :

SUN HUNG KAI
 REAL ESTATE AGENCY LTD.
 42/F SUN HUNG KAI CENTRE, WANCHAI, HONGKONG

ARCHITECT :

lwk&partners
 a r c h i t e c t s

MAIN CONTRACTOR :

怡輝建築有限公司
Yee Fai Building Contractors Ltd.

STRUCTURAL ENGINEER :

ARUP

FAÇADE CONSULTANT:

ALPHA CONSULTING LIMITED
 Steel Structure & Façade Specialist

NOTE :

1. ALL DIMENSIONS ARE IN mm.
2. ALL ELEVATIONS ARE VIEWED FROM OUTSIDE.
3. ALL DIMENSIONS TO BE VERIFIED ON SITE BEFORE FABRICATION.

LEGEND :

- (X1) — DETAIL MARK NO.
- (X001) — REFER SHEET NO.

1. F.F.L. --- FINISHED FLOOR LEVEL
2. S.F.L. --- STRUCTURAL FLOOR LEVEL
3. (R) --- REVERSED DETAIL

4. GLASS LEGEND
- EQ-1 --- 8mmH5+12mm AIR GAP+10mmTP THK. I.G.U.
- EQ-2 --- 10mm THK. CLEAR TEMPERED GLASS
- EQ-4 --- 10mm THK. TEMPERED ACID ETCHED GLASS
- EQ-1A --- 8mmH5+12mm AIR GAP+8mmTP THK. I.G.U.

NO.	DATE	REVISION SUBJECT TO ARCH/COMMENT	BY
A	03/01/2022		

JOB NO. : J-856

PROJECT :
 PROPOSED DEVELOPMENT ABOVE
 LIGHT RAIL TIN WING STOP TSWTL
 NO.23,AREA 33,TIN SHUI WAL, N.T.

TITLE :
 TYPICAL EARTHING
 BONDING DETAILS OF PRECAST

DATE : 02-Aug-21 SCALE : 1:60

DRAWN BY : IYON CHECKED BY :

美特鋁質有限公司
MIDI ALUMINUM FABRICATOR LTD.
 Units 6-8, Sunray Industrial Centre, 1/F
 610 Cho Kwo Ling Road, Kowloon
 Tel:23489211-4 Fax:(852)2727666

DWG NO. : J856-SD-PW-D178 REV. : A