

工程指示 / 要求簡箋 ENGINEER INSTRUCTIONS(E.I.)

工程指示編號:	EI- 4702	修改版本:	-
	HK- 830		
工程編號:	J 856	工程名稱:	TSWTL23
收件人:	生統 / 謝永林 / 王良	發件人:	Bear Lam
工程項目:	T2 佛沙窗大圖(11th Shop Darwing)	日期:	24/05/2022

<input type="checkbox"/> 原合約工程包	<input type="checkbox"/> 原合約工程加 / 減賬 QT-	<input type="checkbox"/> 新工程報價 QT-
---------------------------------	--	------------------------------------

信件批核號碼/圖紙參考編號:	批核模具圖紙編號:
客戶指示附件:	管理內部批簽署:

<input type="checkbox"/> 初步鋁料 B.M.	<input type="checkbox"/> 加工拆圖, 然後生產	<input type="checkbox"/> 尺寸表
<input type="checkbox"/> 正式鋁料 B.M.	<input type="checkbox"/> 技術上資料 / 指示	<input type="checkbox"/> 報價
<input type="checkbox"/> 配件 B.M.	<input type="checkbox"/> 樣辦或貨品說明書	<input type="checkbox"/> 分判合約
<input type="checkbox"/> 其他:		

內容: 現附上最新的圖紙, 請根據最新圖紙進行拆圖, 只需拆T2的圖紙:11th Shop Drawing

完成上列要求日期: 01/06/2022

國內

<input type="checkbox"/> 生產技術總監	<input type="checkbox"/> 連附件	<input type="checkbox"/> 技術部	<input type="checkbox"/> 連附件	<input type="checkbox"/> 生產部	<input type="checkbox"/> 連附件
<input type="checkbox"/> 採購部	<input type="checkbox"/> 連附件	<input checked="" type="checkbox"/> 生產統籌部	<input checked="" type="checkbox"/> 連附件	<input type="checkbox"/> 報關組	<input type="checkbox"/> 連附件
<input type="checkbox"/> 質檢部	<input type="checkbox"/> 連附件	<input type="checkbox"/> 會計部	<input type="checkbox"/> 連附件	<input type="checkbox"/> 機械設計部	<input type="checkbox"/> 連附件
<input checked="" type="checkbox"/> 香港辦	<input checked="" type="checkbox"/> 連附件	<input type="checkbox"/> 其他:			

<input type="checkbox"/> 行政部	<input type="checkbox"/> 連附件	<input type="checkbox"/> 會計部	<input type="checkbox"/> 連附件	<input type="checkbox"/> 統籌部	<input type="checkbox"/> 連附件	<input type="checkbox"/> 工程部	<input type="checkbox"/> 連附件
<input type="checkbox"/> 採購部	<input type="checkbox"/> 連附件	<input type="checkbox"/> QS部	<input type="checkbox"/> 連附件	<input type="checkbox"/> 地盤管理	<input type="checkbox"/> 連附件	<input type="checkbox"/> 維修部	<input type="checkbox"/> 連附件

*發件人簽署:	<i>Bear Lam</i>	*組別成員批核簽署:	<i>Wai</i>
傳遞編號:		項目經理簽署:	<i>Wai, 24/5/2022</i>

PROJECT :

PROPOSED DEVELOPMENT ABOVE
LIGHT RAIL TIN WING STOP, TSWTL
NO.23, AREA 33, TIN SHUI WAI, N.T.

11

SHOP DRAWING FOR ALUM. PRECAST WINDOW OF TOWER

DATE: 18-May-22



美特鋁質有限公司

MIDI ALUMINIUM FABRICATOR LTD.

Units 6-8, Sunray Industrial Centre, 1/F
610 Cha Kwo Ling Road, Kowloon
Tel:23489211-4 Fax:(852)27727666

DRAWING SUBMISSION REGISTER

PROJECT: PROPOSED DEVELOPMENT ABOVE LIGHT RAIL TIN WING STOP, TSWTL NO.23, AREA 33, TIN SHUI WAI, N.T.	DATE OF ISSUE										SUBMISSION STATE (FOR B.D / A.S.D)			SUBMISSION STATE (FOR CLIENT / CONSULTANT)			SUBMISSION STATE (FOR ARCHITECT)			FABRICATION / CONSTRUCTION STATE						
	ISSUE	1	2	3	4	5	6	7	8	9	AP - APPROVED			AP - APPROVED			AP - APPROVED			ISSUE TO CHINA OFFICE		ISSUE TO SITE		ISSUE TO SUB-CONTRACTOR		
	DAY	22	12	18	30	5	29	12	28	18	AC - APPROVED SUB. TO CONDITION			AC - APPROVED SUB. TO CONDITION			AC - APPROVED SUB. TO CONDITION									
	MONTH	9	10	10	10	11	11	1	04	05	NA - NOT APPROVED			NA - NOT APPROVED			NA - NOT APPROVED									
	YEAR	21	21	21	21	21	21	22	22	22																
DRAWING TITLE	DWG. NO.	REVISIONS										COMMENT DATE	REV.	STATE	COMMENT DATE	REV.	STATE	COMMENT DATE	REV.	STATE	REV.	DATE	REV.	DATE	REV.	DATE
COVER PAGE	J856-SD-PW-0000	-	A	B	C	D	E	F	G	H																
DRAWING REGISTER	J856-SD-PW-0001	-	A	A	A	B	C	D	E	F																
DRAWING REGISTER	J856-SD-PW-0002	-	A	A	A	B	C	D	E	F																
GENERAL NOTES FOR ALIM. WINDOW	J856-SD-PW-GN01	-	-																							
EXTRUSION LIST FOR ALIM. WINDOW	J856-SD-PW-1101	-	A	A	A	B	B	B	B	B																
EXTRUSION LIST FOR ALIM. WINDOW	J856-SD-PW-1102	-	-	A	A	A	A	A	A	A																
PLAN FOR ALIM. WINDOW AT TOWER 1(3/F)	J856-SD-PW-3101	-	-	-	-	-	A	B	B	B																
PLAN FOR ALIM. WINDOW AT TOWER 1(5/F-42/F)	J856-SD-PW-3102	-	A	A	A	B	C	D	D	D																
PLAN FOR ALIM. WINDOW AT TOWER 1(43/F)	J856-SD-PW-3103	-	-																							
PLAN FOR ALIM. WINDOW AT TOWER 1(45/F)	J856-SD-PW-3104	-	-																							
PLAN FOR ALIM. WINDOW AT TOWER 1(46/F)	J856-SD-PW-3105	-	-																							
PLAN FOR ALIM. WINDOW AT TOWER 2(3/F)	J856-SD-PW-3201	-	-	-	-	-	A	B	B	C																
PLAN FOR ALIM. WINDOW AT TOWER 2(5/F-42/F)	J856-SD-PW-3202	-	A	A	A	B	C	D	D	E																
PLAN FOR ALIM. WINDOW AT TOWER 2(43/F)	J856-SD-PW-3203	-	-																							
PLAN FOR ALIM. WINDOW AT TOWER 2(45/F)	J856-SD-PW-3204	-	-																							
PLAN FOR ALIM. WINDOW AT TOWER 2(46/F)	J856-SD-PW-3205	-	-																							
PLAN FOR ALIM. WINDOW AT TOWER 3(3/F)	J856-SD-PW-3301	-	-				A	B	C	D																
PLAN FOR ALIM. WINDOW AT TOWER 3(5/F-42/F)	J856-SD-PW-3302	-	A	B	C	D	E	F	H	I																
PLAN FOR ALIM. WINDOW AT TOWER 3(43/F)	J856-SD-PW-3303	-	-																							
PLAN FOR ALIM. WINDOW AT TOWER 3(45/F)	J856-SD-PW-3304	-	-																							
PLAN FOR ALIM. WINDOW AT TOWER 3(46/F)	J856-SD-PW-3305	-	-																							
WINDOW SCHEDULE FOR TOWER 1 ALUM. WINDOW	J856-SD-PW-5101	-	A	A	A	B	C	D	D	D																
WINDOW SCHEDULE FOR TOWER 1 ALUM. WINDOW	J856-SD-PW-5102	-	-	-	-	A	B	C	C	C																
WINDOW SCHEDULE FOR TOWER 1 ALUM. WINDOW	J856-SD-PW-5103	-	-	-	-	A	B	C	C	C																
WINDOW SCHEDULE FOR TOWER 1 ALUM. WINDOW	J856-SD-PW-5104	-	A	A	A	B	C	D	D	D																
WINDOW SCHEDULE FOR TOWER 1 ALUM. WINDOW	J856-SD-PW-5105	-	-	-	-	A	B	C	C	C																
WINDOW SCHEDULE FOR TOWER 1 ALUM. WINDOW	J856-SD-PW-5106	-	A	A	A	B	C	D	D	D																
WINDOW SCHEDULE FOR TOWER 1 ALUM. WINDOW	J856-SD-PW-5107	-	-	-	-	A	B	C	C	C																
WINDOW SCHEDULE FOR TOWER 1 ALUM. WINDOW	J856-SD-PW-5108	-	-	-	-	A	B	C	C	C																
WINDOW SCHEDULE FOR TOWER 1 ALUM. WINDOW	J856-SD-PW-5109	-	A	A	A	B	C	D	D	D																
WINDOW SCHEDULE FOR TOWER 1 ALUM. WINDOW	J856-SD-PW-5110	-	A	A	A	B	C	D	D	D																
WINDOW SCHEDULE FOR TOWER 1 ALUM. WINDOW	J856-SD-PW-5111	-	A	A	A	B	C	D	D	D																
WINDOW SCHEDULE FOR TOWER 1 ALUM. WINDOW	J856-SD-PW-5112	-	A	A	A	A	A	B	B	B																
WINDOW SCHEDULE FOR TOWER 2 ALUM. WINDOW	J856-SD-PW-5201	-	A	A	A	B	C	D	E	F																
WINDOW SCHEDULE FOR TOWER 2 ALUM. WINDOW	J856-SD-PW-5202	-	-	-	-	A	B	C	D	E																
WINDOW SCHEDULE FOR TOWER 2 ALUM. WINDOW	J856-SD-PW-5203	-	-	-	-	A	B	C	D	E																
WINDOW SCHEDULE FOR TOWER 2 ALUM. WINDOW	J856-SD-PW-5204	-	A	A	A	B	C	D	E	F																
WINDOW SCHEDULE FOR TOWER 2 ALUM. WINDOW	J856-SD-PW-5205	-	-	-	-	A	B	C	D	E																
WINDOW SCHEDULE FOR TOWER 2 ALUM. WINDOW	J856-SD-PW-5206	-	A	A	A	B	C	D	E	F																
WINDOW SCHEDULE FOR TOWER 2 ALUM. WINDOW	J856-SD-PW-5207	-	-	-	-	A	B	C	D	E																
WINDOW SCHEDULE FOR TOWER 2 ALUM. WINDOW	J856-SD-PW-5208	-	-	-	-	A	B	C	D	E																
WINDOW SCHEDULE FOR TOWER 2 ALUM. WINDOW	J856-SD-PW-5209	-	A	A	A	B	C	D	E	F																
WINDOW SCHEDULE FOR TOWER 2 ALUM. WINDOW	J856-SD-PW-5210	-	A	A	A	B	C	D	E	F																
WINDOW SCHEDULE FOR TOWER 2 ALUM. WINDOW	J856-SD-PW-5211	-	A	A	A	B	C	D	E	F																

IN-HOUSE DESIGN CHECKER

美特鋁質有限公司
MIDI ALUMINIUM FABRICATOR LTD.
 Units 6-8, Sunray Industrial Centre, 1/F
 610 Cha Kwo Ling Road, Kowloon
 Tel:23489211-4 Fax:(852)2727666

DWC NO. : J856-SD-PW-0001 REV. : F

DRAWING SUBMISSION REGISTER

PROJECT: PROPOSED DEVELOPMENT ABOVE LIGHT RAIL TIN WING STOP, TSWTL NO.23, AREA 33, TIN SHUI WAI, N.T.	DATE OF ISSUE										SUBMISSION STATE (FOR B.D / A.S.D)			SUBMISSION STATE (FOR CLIENT / CONSULTANT)			SUBMISSION STATE (FOR ARCHITECT)			FABRICATION / CONSTRUCTION STATE								
	ISSUE	1	2	3	4	5	6	7	8	9	AP - APPROVED			AP - APPROVED			AP - APPROVED			ISSUE TO CHINA OFFICE		ISSUE TO SITE		ISSUE TO SUB-CONTRACTOR				
	DAY	22	12	18	30	2	29	12	28	18	AC - APPROVED SUB. TO CONDITION			AC - APPROVED SUB. TO CONDITION			AC - APPROVED SUB. TO CONDITION											
	MONTH	9	10	10	10	11	11	1	04	05	NA - NOT APPROVED			NA - NOT APPROVED			NA - NOT APPROVED											
	YEAR	21	21	21	21	21	21	22	22	22																		
DRAWING TITLE	DWG. NO.	REVISIONS										COMMENT DATE	REV.	STATE	COMMENT DATE	REV.	STATE	COMMENT DATE	REV.	STATE	REV.	DATE	REV.	DATE	REV.	DATE		
WINDOW SCHEDULE FOR TOWER 2 ALUM. WINDOW	J856-SD-PW-5212	-	-										A	A	B													
WINDOW SCHEDULE FOR TOWER 2 ALUM. WINDOW	J856-SD-PW-5213	-	-																									
WINDOW SCHEDULE FOR TOWER 2 ALUM. WINDOW	J856-SD-PW-5214	-	A																									
WINDOW SCHEDULE FOR TOWER 3 ALUM. WINDOW	J856-SD-PW-5301	-	-	A	B	C	D	E	G	G																		
WINDOW SCHEDULE FOR TOWER 3 ALUM. WINDOW	J856-SD-PW-5302	-	A	B	C	D	E	F	H	H																		
WINDOW SCHEDULE FOR TOWER 3 ALUM. WINDOW	J856-SD-PW-5303	-	A	B	C	D	E	F	H	H																		
WINDOW SCHEDULE FOR TOWER 3 ALUM. WINDOW	J856-SD-PW-5303a																											
WINDOW SCHEDULE FOR TOWER 3 ALUM. WINDOW	J856-SD-PW-5304	-	A	B	C	D	E	F	H	H																		
WINDOW SCHEDULE FOR TOWER 3 ALUM. WINDOW	J856-SD-PW-5305	-	A	B	C	D	E	F	H	H																		
WINDOW SCHEDULE FOR TOWER 3 ALUM. WINDOW	J856-SD-PW-5306	-	-	A	B	C	D	E	G	G																		
WINDOW SCHEDULE FOR TOWER 3 ALUM. WINDOW	J856-SD-PW-5307	-	-	A	B	C	D	E	G	H																		
WINDOW SCHEDULE FOR TOWER 3 ALUM. WINDOW	J856-SD-PW-5308	-	A	B	C	D	E	F	H	I																		
WINDOW SCHEDULE FOR TOWER 3 ALUM. WINDOW	J856-SD-PW-5309	-	A	B	C	D	E	F	H	H																		
WINDOW SCHEDULE FOR TOWER 3 ALUM. WINDOW	J856-SD-PW-5309a																											
WINDOW SCHEDULE FOR TOWER 3 ALUM. WINDOW	J856-SD-PW-5310	-	A	B	B	B	C	D	H	I																		
WINDOW SCHEDULE FOR TOWER 3 ALUM. WINDOW	J856-SD-PW-5311	-	-	A	B	B	B	C	E	E																		
WINDOW SCHEDULE FOR TOWER 3 ALUM. WINDOW	J856-SD-PW-5312	-	-	A	A	A	A	B	D	D																		
WINDOW SCHEDULE FOR TOWER 3 ALUM. WINDOW	J856-SD-PW-5313	-	A	B	B	B	B	C	D	D																		
TYPICAL DETAILS FOR ALUM. WINDOW	J856-SD-PW-DT61	-	-	-	A	B	B	B	B	B																		
TYPICAL DETAILS FOR ALUM. WINDOW	J856-SD-PW-DT61a	-	-	-	A	B	B	B	B	B																		
TYPICAL DETAILS FOR ALUM. WINDOW	J856-SD-PW-DT62	-	A	A	B	C	C	C	C	C																		
TYPICAL DETAILS FOR ALUM. WINDOW	J856-SD-PW-DT63	-	A	A	B	C	C	C	C	C																		
TYPICAL DETAILS FOR ALUM. WINDOW	J856-SD-PW-DT64	-	A	B	C	D	D	D	D	D																		
TYPICAL DETAILS FOR ALUM. WINDOW	J856-SD-PW-DT71	-	-	-	A	B	B	B	B	B																		
TYPICAL DETAILS FOR ALUM. WINDOW	J856-SD-PW-DT71a	-	-	-	A	B	B	B	B	B																		
TYPICAL DETAILS FOR ALUM. WINDOW	J856-SD-PW-DT72	-	-	-	A	B	B	B	B	B																		
TYPICAL DETAILS FOR ALUM. WINDOW	J856-SD-PW-DT73	-	A	A	B	C	C	C	C	C																		
TYPICAL DETAILS FOR ALUM. WINDOW	J856-SD-PW-DT73a																											
ALUM. WINDOW SECTION TYPICAL LOCK & HINGES DETAIL	J856-SD-PW-DT74	-	-	-	-	-	-	-	-	-																		
G.M.S FIXING LUG TYPICAL DETAIL FOR ALUM. WINDOW	J856-SD-PW-DT74A	-	-	-	-	-	-	-	-	-																		
G.M.S FIXING LUG TYPICAL DETAIL FOR ALUM. WINDOW	J856-SD-PW-DT75	-	-	-	-	-	-	-	-	-																		
TYPICAL EARTHING BONDING DETAILS OF PRECAST	J856-SD-PW-DT76	-	-	-	-	-	-	-	-	-																		
TYPICAL EARTHING BONDING DETAILS OF PRECAST	J856-SD-PW-DT77	-	-	-	-	-	-	-	-	-																		
TYPICAL EARTHING BONDING DETAILS OF PRECAST	J856-SD-PW-DT78	-	-	-	-	-	-	-	-	-																		

IN-HOUSE DESIGN CHECKER



美特鋁質有限公司
MIDI ALUMINIUM FABRICATOR LTD.

Units 6-8, Sunray Industrial Centre, 1/F
610 Cha Kwo Ling Road, Kowloon
Tel: 23489211-4 Fax: (852) 27727666

DWG NO. : J856-SD-PW-0002 REV. : F

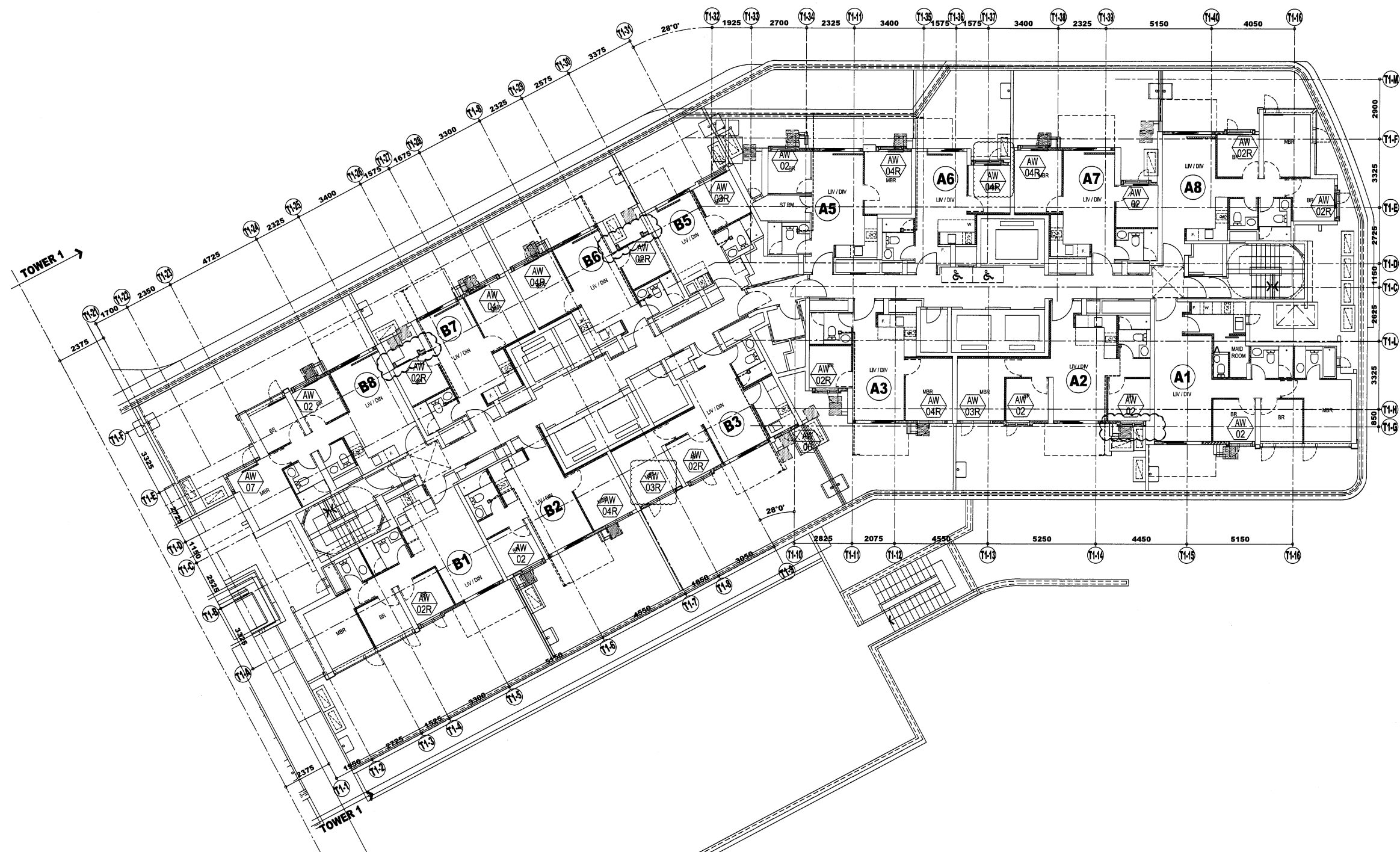

TOWER 1 3/F

B.D. REF :

CLIENT :

SUN HUNG KAI
REAL ESTATE AGENCY LTD.
42/F SUN HUNG KAI CENTRE, WANCHAI, HONGKONG

ARCHITECT :

lwk&partners
architects

MAIN CONTRACTOR :

Yee Fai Building Contractors Ltd.

STRUCTURAL ENGINEER :

ARUP

FAÇADE CONSULTANT:

ALPHA CONSULTING LIMITED
Steel Structure & Façade Specialist

NOTE :

1. ALL DIMENSIONS ARE IN mm.
2. ALL ELEVATIONS ARE VIEWED FROM OUTSIDE.
3. ALL DIMENSIONS TO BE VERIFIED ON SITE BEFORE FABRICATION.

LEGEND :

- X1 --- DETAIL MARK NO.
- X001 --- REFER SHEET NO.

1. F.F.L. --- FINISHED FLOOR LEVEL
2. S.F.L. --- STRUCTURAL FLOOR LEVEL
3. --- REVERSED DETAIL
4. GLASS LEGEND

EGL-1---8mmHS+12mm AIR GAP+8mmTP THK. I.G.U.
EGL-2---10mm THK. CLEAR TEMPERED GLASS
EGL-4---10mm THK. TEMPERED ACID ETCHED GLASS

B	21/12/2021	REVISION SUBJECT TO ARCH.COMMENT	ivan
A	29/10/2021	REVISION SUBJECT TO ARCH.COMMENT	ivan
NO.	DATE	REVISED	BY

JOB NO. : J-856

PROJECT :
PROPOSED DEVELOPMENT ABOVE
LIGHT RAIL TIN WING STOP, TSWTL
NO.23, AREA 33, TIN SHUI WAI, N.T.

TITLE :
PLAN FOR ALUM. WINDOW
AT TOWER 1

DATE : 02-Aug-21 SCALE : 1:40

DRAWN BY : ivan CHECKED BY :

美特鋁質有限公司
MIDI ALUMINIUM FABRICATOR LTD.
Units 6-8, Sunray Industrial Centre, 1/F
610 Cha Kwo Ling Road, Kowloon
Tel: 23489211-4 Fax: (852) 2727666

DWG NO. : JB56-SD-PW-3101 REV. : B

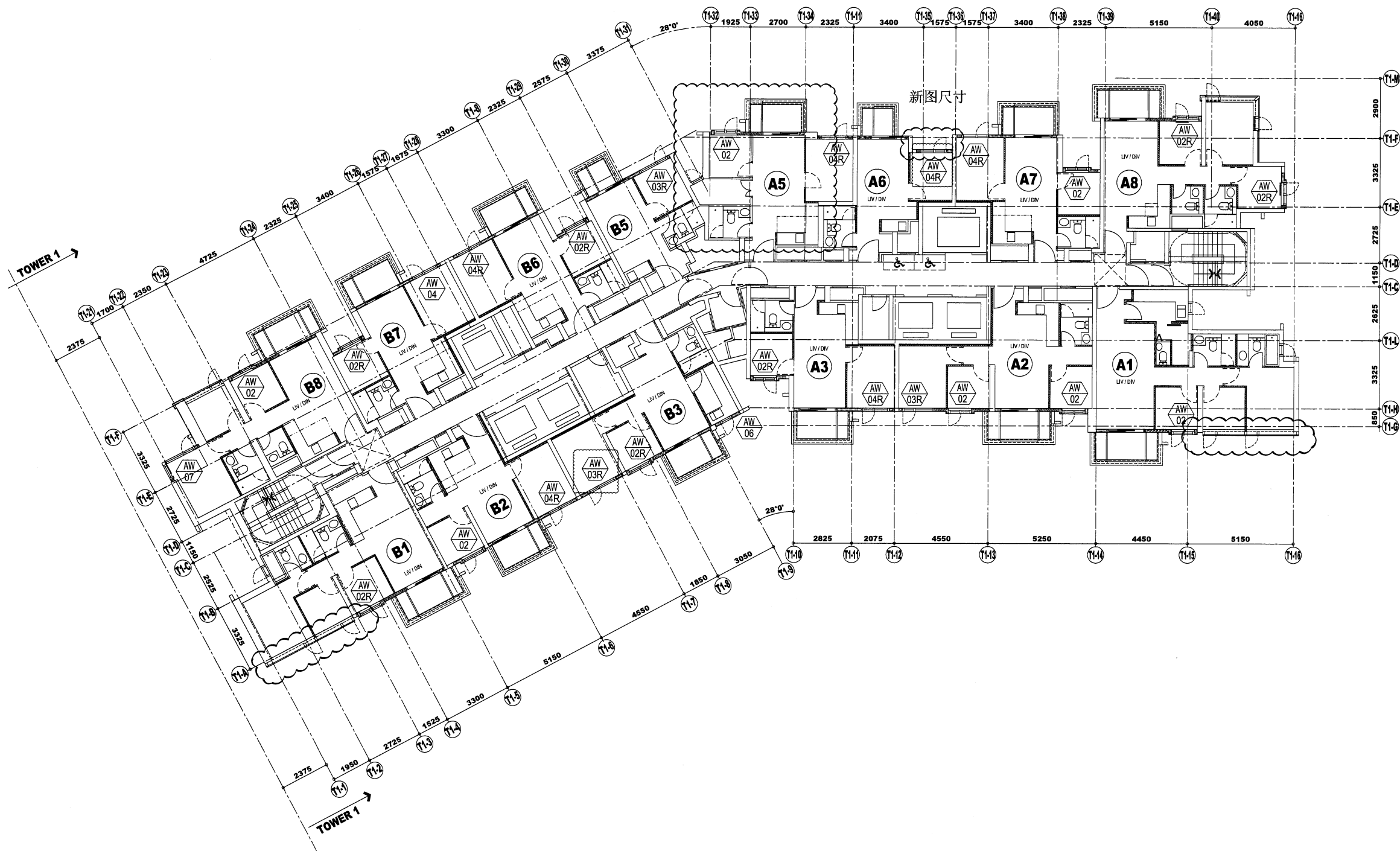

TOWER 1 5/F-42/F

B.D. REF :

CLIENT :
SUN HUNG KAI
 REAL ESTATE AGENCY LTD.
 42/F SUN HUNG KAI CENTRE, WANCHAI, HONGKONG

ARCHITECT :
lwk&partners
 architects

MAIN CONTRACTOR :
Yee Fai Building Contractors Ltd.

STRUCTURAL ENGINEER :
ARUP

FACADE CONSULTANT:
ALPHA CONSULTING LIMITED
 Steel Structure & Facade Specialist

NOTE :
 1. ALL DIMENSIONS ARE IN mm.
 2. ALL ELEVATIONS ARE VIEWED FROM OUTSIDE.
 3. ALL DIMENSIONS TO BE VERIFIED ON SITE BEFORE FABRICATION.

LEGEND :
 X1 --- DETAIL MARK NO.
 X001 --- REFER SHEET NO.
 1. F.F.L. --- FINISHED FLOOR LEVEL
 2. S.F.L. --- STRUCTURAL FLOOR LEVEL
 3. (B) --- REVERSED DETAIL
 4. GLASS LEGEND
 EGL-1--8mmHS+12mm AIR GAP+8mmTP THK. I.G.U.
 EGL-2--10mm THK. CLEAR TEMPERED GLASS
 EGL-4--10mm THK. TEMPERED ACID ETCHED GLASS

NO.	DATE	REVISION	BY
C	29/11/2021	REVISION SUBJECT TO ARCH.COMMENT	Ivan
B	03/11/2021	REVISION SUBJECT TO ARCH.COMMENT	Ivan
A	18/10/2021	REVISION SUBJECT TO ARCH.COMMENT	Ivan

JOB NO. : J-856
 PROJECT : PROPOSED DEVELOPMENT ABOVE LIGHT RAIL TIN WING STOP, TSWTL NO.23, AREA 33, TIN SHUI WAI, N.T.

TITLE : PLAN FOR IN-SITU WINDOW AT TOWER 1

DATE : 02-Aug-21 SCALE : 1:40
 DRAWN BY : Ivan CHECKED BY :

美特鋁質有限公司
MIDI ALUMINIUM FABRICATOR LTD.
 Units 6-8, Sunray Industrial Centre, 1/F
 610 Cha Kwo Ling Road, Kowloon
 Tel:23489211-4 Fax:(852)2727666

DWG NO. : J856-SD-IW-3102 REV. : C

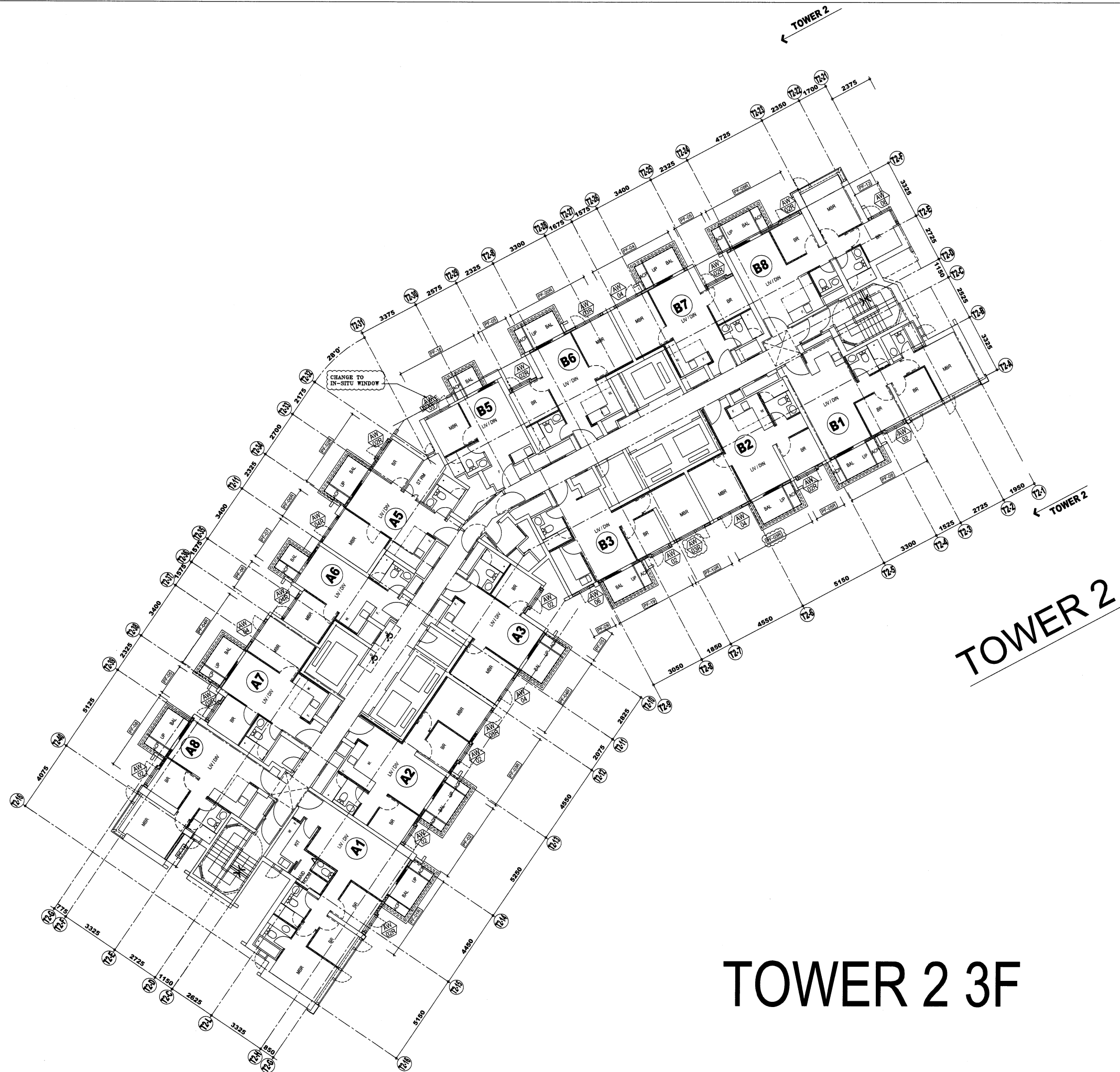

TOWER 2 3F

B.D. REF :

CLIENT :

SUN HUNG KAI
REAL ESTATE AGENCY LTD.
42/F SUN HUNG KAI CENTRE, WANCHAI, HONGKONG

ARCHITECT :

lwk&partners
architects

MAIN CONTRACTOR :

Yee Fai Building Contractors Ltd.

STRUCTURAL ENGINEER :

ARUP

FACADE CONSULTANT :

ALPHA CONSULTING LIMITED
Steel Structure & Facade Specialist

NOTE :

1. ALL DIMENSIONS ARE IN mm.
2. ALL ELEVATIONS ARE VIEWED FROM OUTSIDE.
3. ALL DIMENSIONS TO BE VERIFIED ON SITE BEFORE FABRICATION.

LEGEND :

- X1 --- DETAIL MARK NO.
- X001 --- REFER SHEET NO.

1. F.F.L. --- FINISHED FLOOR LEVEL
2. S.F.L. --- STRUCTURAL FLOOR LEVEL
3. /B --- REVERSED DETAIL
4. GLASS LEGEND

EGL-1---8mmHS+12mm AIR GAP+8mmTP THK. I.G.U.
EGL-2---10mm THK. CLEAR TEMPERED GLASS
EGL-4---10mm THK. TEMPERED ACID ETCHED GLASS

NO.	DATE	REVISED	BY
C	18/5/2022	REVISION SUBJECT TO ARCH.COMMENT	lvon
B	12/1/2022	REVISION SUBJECT TO ARCH.COMMENT	lvon
A	26/11/2021	REVISION SUBJECT TO ARCH.COMMENT	lvon

JOB NO. : J-856

PROJECT :
PROPOSED DEVELOPMENT ABOVE
LIGHT RAIL TIN WING STOP, TSWTL
NO.23, AREA 33, TIN SHUI WAI, N.T.

TITLE :
PLAN FOR PRECAST WINDOW
AT TOWER 2

DATE : 02-Aug-21 SCALE : 1:40

DRAWN BY : lvon CHECKED BY :

美特鋁質有限公司
MIDI ALUMINIUM FABRICATOR LTD.
Units 6-8, Sunray Industrial Centre, 1/F
610 Cha Kwo Ling Road, Kowloon
Tel: 23489211-4 Fax: (852) 2727666

DWG NO. : J856-SD-IW-3202 REV. : C

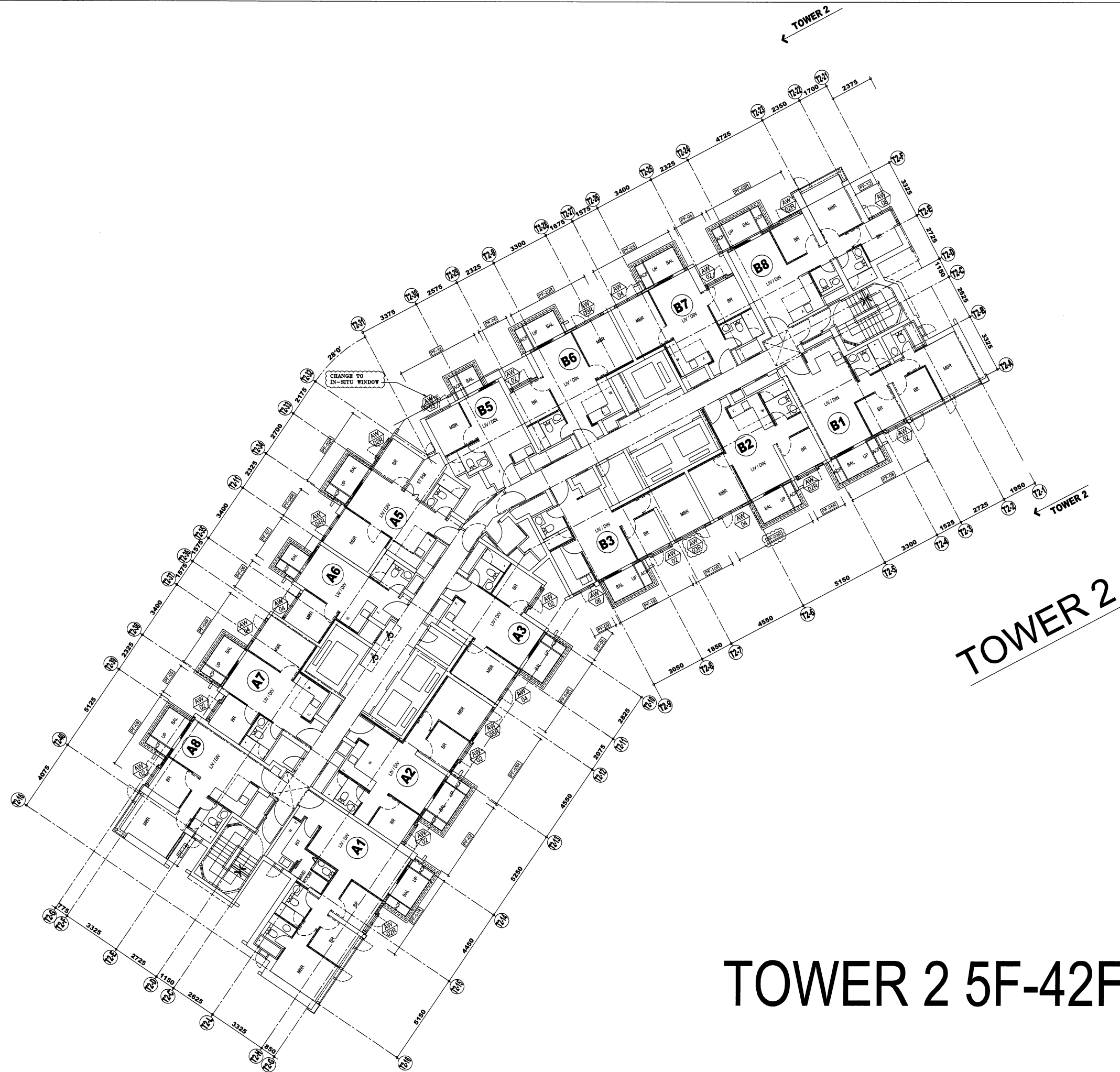

TOWER 2 5F-42F

B.D. REF :

CLIENT :
SUN HUNG KAI
 REAL ESTATE AGENCY LTD.
 42/F SUN HUNG KAI CENTRE, WANCHAI, HONGKONG

ARCHITECT :
lwk&partners
 architects

MAIN CONTRACTOR :
Yee Fai Building Contractors Ltd.

STRUCTURAL ENGINEER :
ARUP

FACADE CONSULTANT:
ALPHA CONSULTING LIMITED
 Steel Structure & Facade Specialist

NOTE :
 1. ALL DIMENSIONS ARE IN mm.
 2. ALL ELEVATIONS ARE VIEWED FROM OUTSIDE.
 3. ALL DIMENSIONS TO BE VERIFIED ON SITE BEFORE FABRICATION.

LEGEND :
 X1 --- DETAIL MARK NO.
 X001 --- REFER SHEET NO.
 1. F.F.L. --- FINISHED FLOOR LEVEL
 2. S.F.L. --- STRUCTURAL FLOOR LEVEL
 3. (Z) --- REVERSED DETAIL
 4. GLASS LEGEND
 EGL-1 --- 8mmHS+12mm AIR GAP+8mmTP THK. I.G.U.
 EGL-2 --- 10mm THK. CLEAR TEMPERED GLASS
 EGL-4 --- 10mm THK. TEMPERED ACID ETCHED GLASS

NO.	DATE	REVISED	BY
E	18/5/2022	REVISION SUBJECT TO ARCH.COMMENT	Ivan
D	12/1/2022	REVISION SUBJECT TO ARCH.COMMENT	Ivan
C	26/11/2021	REVISION SUBJECT TO ARCH.COMMENT	Ivan
B	03/11/2021	REVISION SUBJECT TO ARCH.COMMENT	Ivan
A	18/10/2021	REVISION SUBJECT TO ARCH.COMMENT	Ivan

JOB NO. : J-856
 PROJECT : PROPOSED DEVELOPMENT ABOVE LIGHT RAIL TIN WING STOP, TSWTL NO.23, AREA 33, TIN SHUI WAI, N.T.

TITLE : PLAN FOR PRECAST WINDOW AT TOWER 2

DATE : 02-Aug-21 SCALE : 1:40
 DRAWN BY : Ivan CHECKED BY :

美特鋁質有限公司
MIDI ALUMINIUM FABRICATOR LTD.
 Units 6-8, Sunray Industrial Centre, 1/F
 610 Cha Kwo Ling Road, Kowloon
 Tel: 23489211-4 Fax: (852) 2727666

DWG NO. : J856-SD-IW-3202 REV. : E

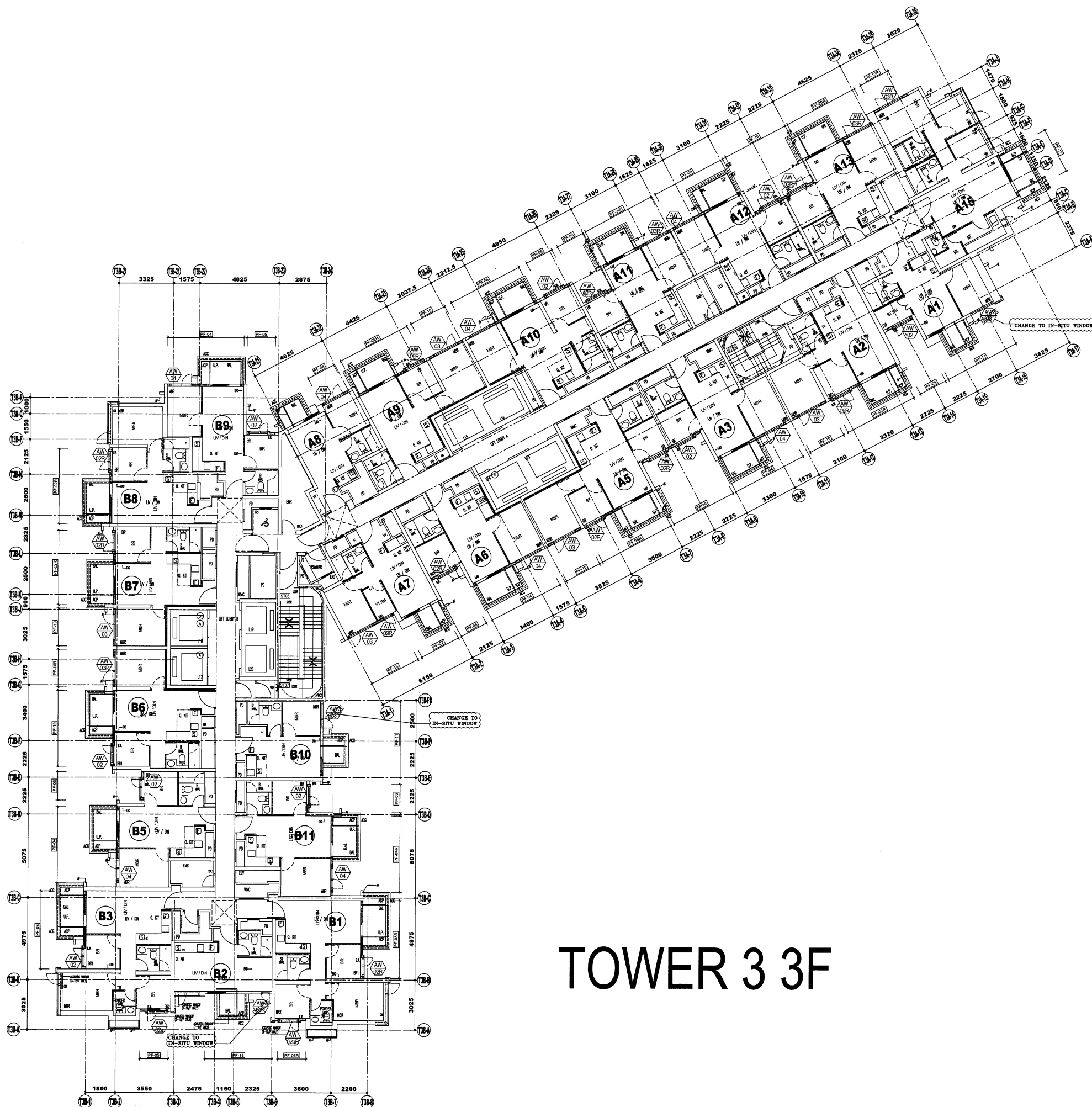

TOWER 3 3F

B.D. REF :

CLIENT :
SUN HUNG KAI
 REAL ESTATE AGENCY LTD.
 42/F SUN HUNG KAI CENTRE, WANCHAI, HONGKONG

ARCHITECT :
lwk&partners
 architects

MAIN CONTRACTOR :
Yee Fai Building Contractors Ltd.

STRUCTURAL ENGINEER :
ARUP

FACADE CONSULTANT:
ALPHA CONSULTING LIMITED
 Steel Structure & Facade Specialist

NOTE :
 1. ALL DIMENSIONS ARE IN mm.
 2. ALL ELEVATIONS ARE VIEWED FROM OUTSIDE.
 3. ALL DIMENSIONS TO BE VERIFIED ON SITE BEFORE FABRICATION.

LEGEND :
 X1 — DETAIL MARK NO.
 X001 — REFER SHEET NO.
 1. F.F.L. --- FINISHED FLOOR LEVEL
 2. S.F.L. --- STRUCTURAL FLOOR LEVEL
 3. (Z) --- REVERSED DETAIL
 4. GLASS LEGEND
 EGL-1 --- 8mmHS+12mm AIR GAP+8mmTP THK. I.G.U.
 EGL-2 --- 10mm THK. CLEAR TEMPERED GLASS
 EGL-4 --- 10mm THK. TEMPERED ACID ETCHED GLASS

NO.	DATE	REVISED	BY
D	18/05/2022	REVISION SUBJECT TO ARCH.COMMENT	lvon
C	22/04/2022	REVISION SUBJECT TO ARCH.COMMENT	lvon
B	21/12/2021	REVISION SUBJECT TO ARCH.COMMENT	lvon
A	29/11/2021	REVISION SUBJECT TO ARCH.COMMENT	lvon

JOB NO. : J-856
 PROJECT : PROPOSED DEVELOPMENT ABOVE LIGHT RAIL TIN WING STOP, TSWTL NO.23, AREA 33, TIN SHUI WAI, N.T.

TITLE : PLAN FOR PRECAST WINDOW AT TOWER 3

DATE : 02-Aug-21 SCALE : 1:40
 DRAWN BY : lvon CHECKED BY :

美特鋁質有限公司
 MIDI ALUMINIUM FABRICATOR LTD.
 Units 6-8, Sunray Industrial Centre, 1/F
 610 Cha Kwo Ling Road, Kowloon
 Tel: 23489211-4 Fax: (852) 2727666

DWG NO. : J856-SD-IW-3301 REV. : D

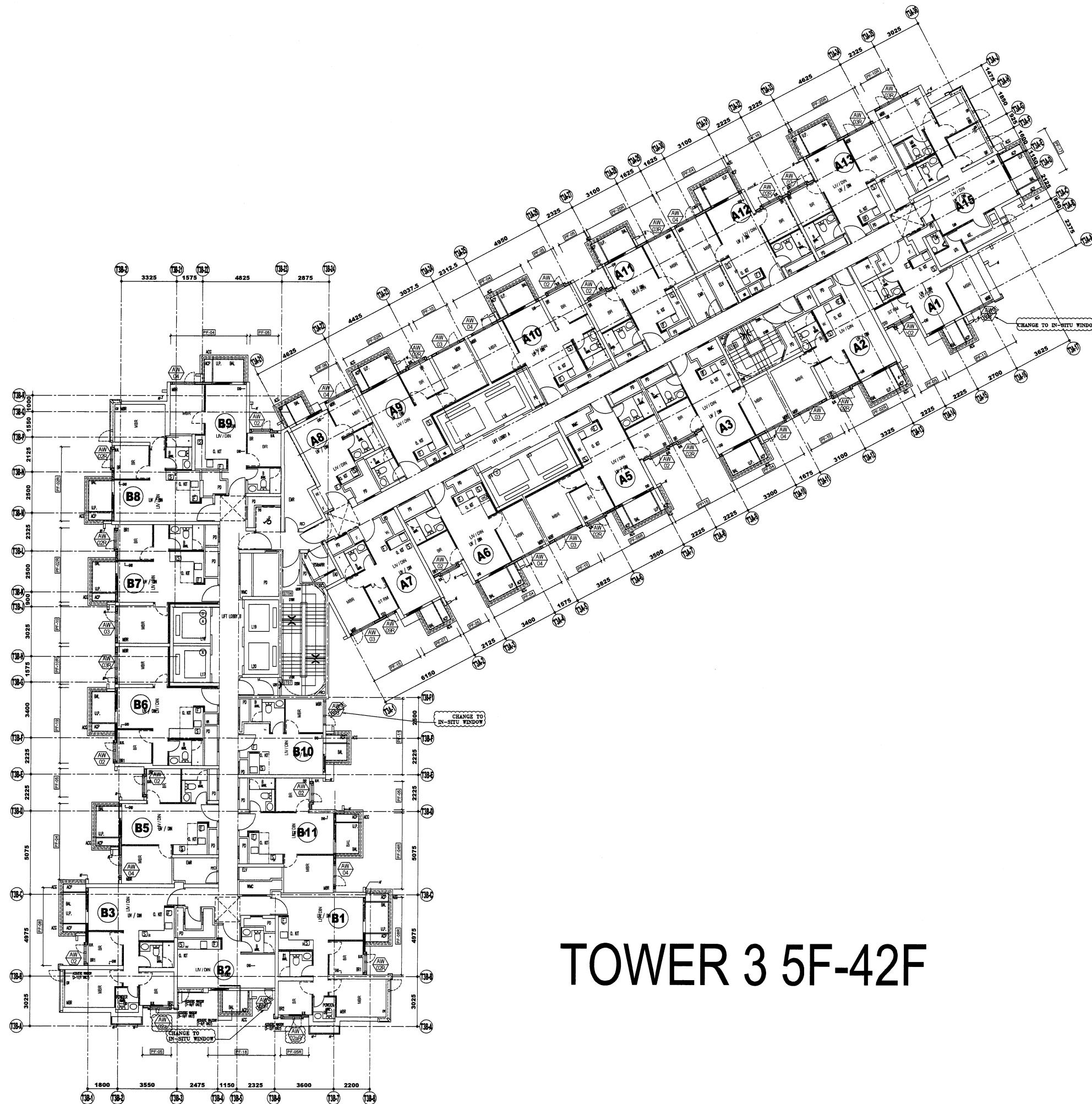

TOWER 3 5F-42F

B.D. REF :

CLIENT :

SUN HUNG KAI
REAL ESTATE AGENCY LTD.
42/F SUN HUNG KAI CENTRE, WANCHAI, HONGKONG

ARCHITECT :

lwk&partners
architects

MAIN CONTRACTOR :

Yee Fai Building Contractors Ltd.

STRUCTURAL ENGINEER :

ARUP

FACADE CONSULTANT:

ALPHA CONSULTING LIMITED
Steel Structure & Facade Specialist

NOTE :

1. ALL DIMENSIONS ARE IN mm.
2. ALL ELEVATIONS ARE VIEWED FROM OUTSIDE.
3. ALL DIMENSIONS TO BE VERIFIED ON SITE BEFORE FABRICATION.

LEGEND :

- X1 --- DETAIL MARK NO.
- X001 --- REFER SHEET NO.

1. F.F.L. --- FINISHED FLOOR LEVEL
2. S.F.L. --- STRUCTURAL FLOOR LEVEL
3. (R) --- REVERSED DETAIL
4. GLASS LEGEND

EGL-1--8mmHS+12mm AIR GAP+8mmTP THK. I.G.U.

EGL-2--10mm THK. CLEAR TEMPERED GLASS

EGL-4--10mm THK. TEMPERED ACID ETCHED GLASS

NO.	DATE	REVISED	BY
I	18/05/2022	REVISION SUBJECT TO ARCH.COMMENT	lvan
H	22/04/2022	REVISION SUBJECT TO ARCH.COMMENT	lvan
G	08/04/2022	REVISION SUBJECT TO ARCH.COMMENT	lvan
F	12/01/2022	REVISION SUBJECT TO ARCH.COMMENT	lvan
E	29/11/2021	REVISION SUBJECT TO ARCH.COMMENT	lvan
D	02/11/2021	REVISION SUBJECT TO ARCH.COMMENT	lvan
C	28/10/2021	REVISION SUBJECT TO ARCH.COMMENT	lvan
B	18/10/2021	REVISION SUBJECT TO ARCH.COMMENT	lvan
A	30/09/2021	REVISION SUBJECT TO ARCH.COMMENT	lvan

JOB NO. : J-856

PROJECT :
PROPOSED DEVELOPMENT ABOVE
LIGHT RAIL TIN WING STOP, TSWTL
NO.23, AREA 33, TIN SHUI WAI, N.T.

TITLE :
PLAN FOR PRECAST WINDOW
AT TOWER 3

DATE : 02-Aug-21 SCALE : 1:40

DRAWN BY : lvan CHECKED BY :

美特鋁質有限公司
MIDI ALUMINIUM FABRICATOR LTD.
Units 6-8, Sunray Industrial Centre, 1/F
610 Cha Kwo Ling Road, Kowloon
Tel: 23489211-4 Fax: (852) 2727666

DWG NO. : J856-SD-IW-3302 REV. : I

ELEVATION

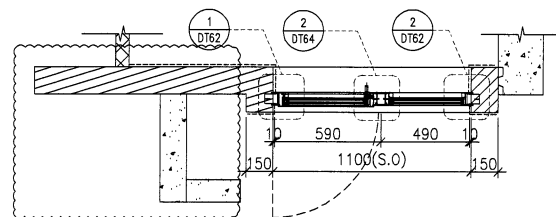
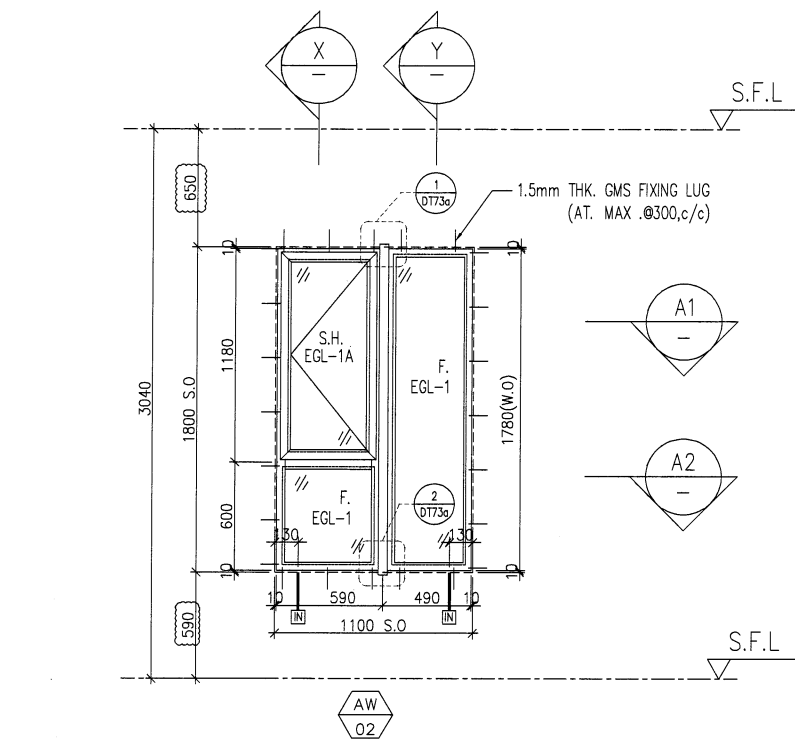

A1 PART PLAN

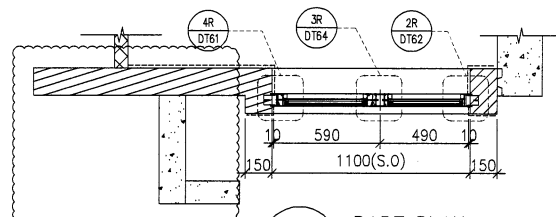

A2 PART PLAN

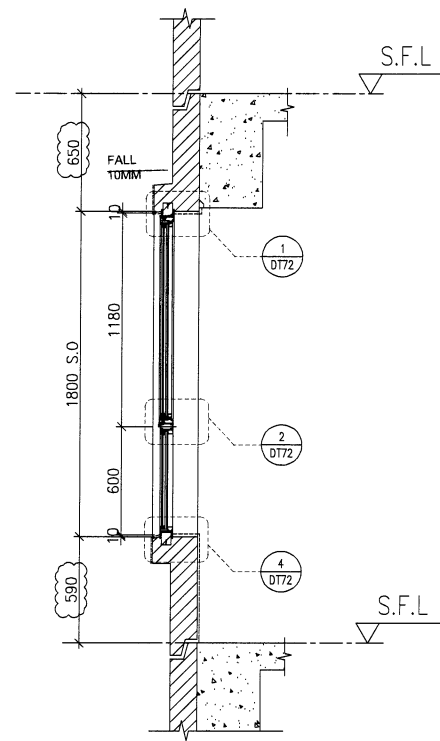

X PART SECTION

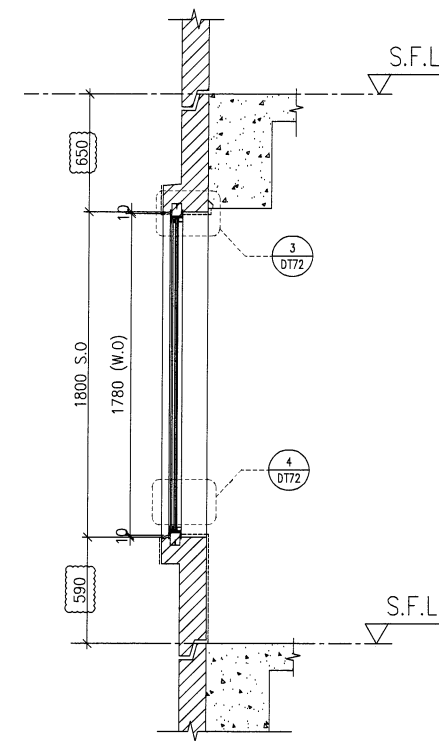

Y PART SECTION

B.D. REF :

CLIENT :
SUN HUNG KAI
 REAL ESTATE AGENCY LTD.
 42/F SUN HUNG KAI CENTRE, WANCHAI, HONGKONG

ARCHITECT :
lwk&partners
 architects

MAIN CONTRACTOR :
怡輝建築有限公司
Yee Fai Building Contractors Ltd.

STRUCTURAL ENGINEER :
ARUP

FACADE CONSULTANT:
ALPHA CONSULTING LIMITED
 Steel Structure & Facade Specialist

NOTE :
 1. ALL DIMENSIONS ARE IN mm.
 2. ALL ELEVATIONS ARE VIEWED FROM OUTSIDE.
 3. ALL DIMENSIONS TO BE VERIFIED ON SITE BEFORE FABRICATION.

LEGEND :
 X1 — DETAIL MARK NO.
 X001 — REFER SHEET NO.

1. F.F.L. --- FINISHED FLOOR LEVEL
 2. S.F.L. --- STRUCTURAL FLOOR LEVEL
 3. (R) --- REVERSED DETAIL
 4. GLASS LEGEND
 EGL-1--8mmHS+12mm AIR GAP+10mmTP THK. I.G.U.
 EGL-2--10mm THK. CLEAR TEMPERED GLASS
 EGL-4--10mm THK. TEMPERED ACID ETCHED GLASS
 EGL-1A--8mmHS+12mm AIR GAP+8mmTP THK. I.G.U.

NO.	DATE	REVISED	BY
D	17/12/2021	REVISION SUBJECT TO ARCH.COMMENT	ivan
C	29/11/2021	REVISION SUBJECT TO ARCH.COMMENT	ivan
B	03/11/2021	REVISION SUBJECT TO ARCH.COMMENT	ivan
A	12/10/2021	REVISION SUBJECT TO ARCH.COMMENT	ivan

JOB NO. : J-856
 PROJECT : PROPOSED DEVELOPMENT ABOVE LIGHT RAIL TIN WING STOP, TSWTL NO.23, AREA 33, TIN SHUI WAI, N.T.

TITLE : WINDOW SCHEDULE FOR TOWER 1 ALUM. WINDOW

DATE : 02-Aug-21 SCALE : 1:40
 DRAWN BY : Ivan CHECKED BY :

美特鋁質有限公司
MIDI ALUMINIUM FABRICATOR LTD.
 Units 6-8, Sunray Industrial Centre, 1/F
 610 Cha Kwo Ling Road, Kowloon
 Tel:23489211-4 Fax:(852)27727666

DWG NO. : J856-SD-PW-5101 REV. : D

WINDOW MARK	AW 02
LOCATION	3/F-42/F(4/F,13/F,14/F,24/F,34/F OMITTED) UNIT A1
SECTION	70mm ALUM. SECTION
GLAZING	EGL-1,EGL-1A
QUANTITY	35 Nos.
REMARKS	FACADE(TYPE T1PF01 FOR 3/F~42/F)

ELEVATION

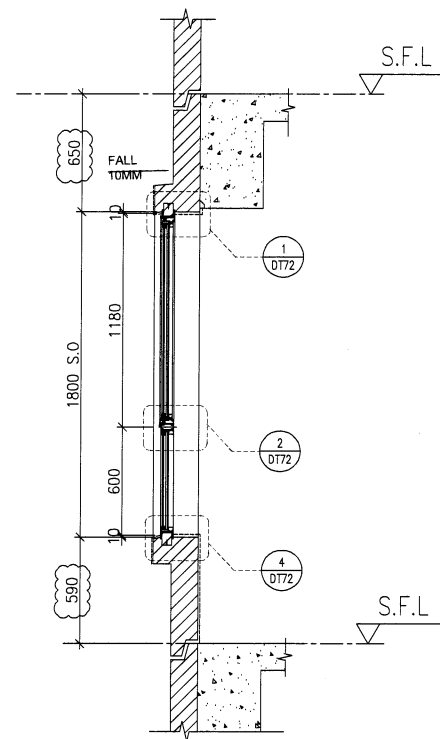
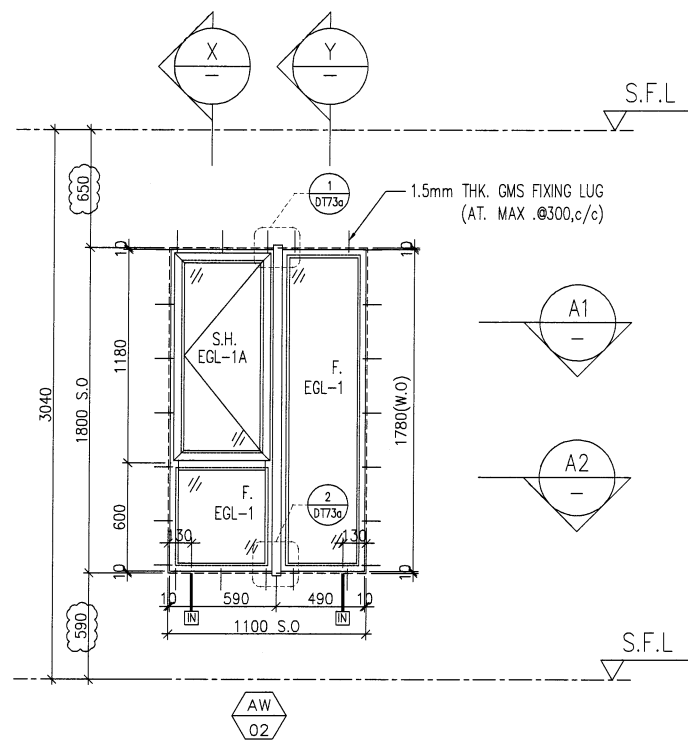

X PART SECTION

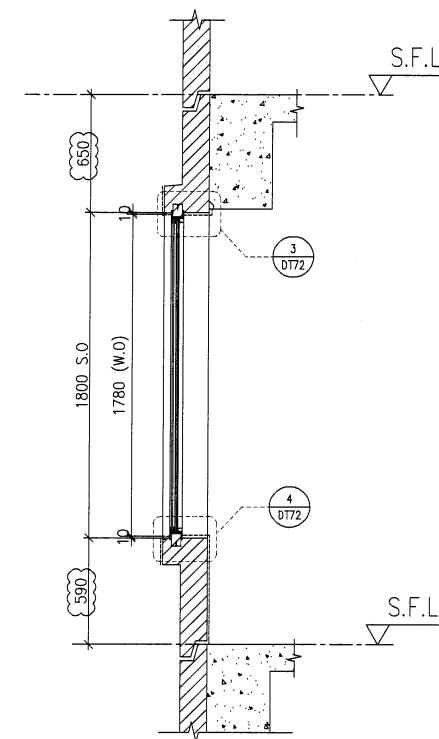

Y PART SECTION

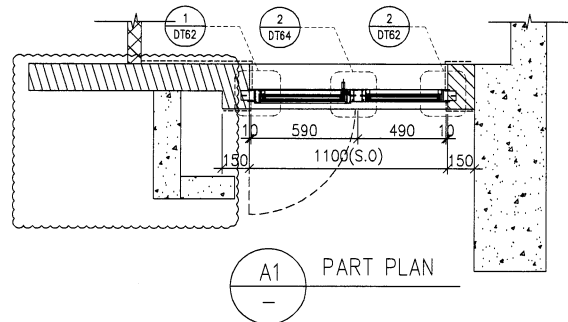

A1 PART PLAN

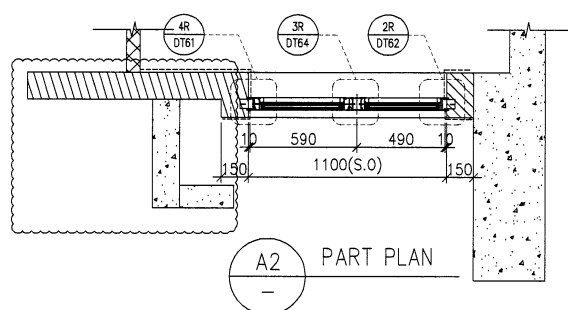

A2 PART PLAN

B.D. REF :

CLIENT :
SUN HUNG KAI
 REAL ESTATE AGENCY LTD.
 42/F SUN HUNG KAI CENTRE, WANCHAI, HONGKONG

ARCHITECT :
lwk&partners
 architects

MAIN CONTRACTOR :
怡輝建築有限公司
Yee Fai Building Contractors Ltd.

STRUCTURAL ENGINEER :
ARUP

FACADE CONSULTANT:
ALPHA CONSULTING LIMITED
 Steel Structure & Facade Specialist

NOTE :
 1. ALL DIMENSIONS ARE IN mm.
 2. ALL ELEVATIONS ARE VIEWED FROM OUTSIDE.
 3. ALL DIMENSIONS TO BE VERIFIED ON SITE BEFORE FABRICATION.

LEGEND :
 XI — DETAIL MARK NO.
 X001 — REFER SHEET NO.
 1. F.F.L. — FINISHED FLOOR LEVEL
 2. S.F.L. — STRUCTURAL FLOOR LEVEL
 3. (R) — REVERSED DETAIL
 4. GLASS LEGEND
 EGL-1 — 8mmHS+12mm AIR GAP+10mmTP THK. I.G.U.
 EGL-2 — 10mm THK. CLEAR TEMPERED GLASS
 EGL-4 — 10mm THK. TEMPERED ACID ETCHED GLASS
 EGL-1A — 8mmHS+12mm AIR GAP+8mmTP THK. I.G.U.

NO.	DATE	REVISION	BY
C	17/12/2021	REVISION SUBJECT TO ARCH.COMMENT	ivan
B	29/11/2021	REVISION SUBJECT TO ARCH.COMMENT	ivan
A	03/11/2021	REVISION SUBJECT TO ARCH.COMMENT	ivan

JOB NO. : J-856
 PROJECT : PROPOSED DEVELOPMENT ABOVE LIGHT RAIL TIN WING STOP, TSWTL NO.23, AREA 33, TIN SHUI WAI, N.T.

TITLE : WINDOW SCHEDULE FOR TOWER 1 ALUM. WINDOW

DATE : 02-Aug-21 SCALE : 1:40

DRAWN BY : lvan CHECKED BY :

美特鋁質有限公司
MIDI ALUMINIUM FABRICATOR LTD.
 Units 6-8, Sunray Industrial Centre, 1/F
 610 Cha Kwo Ling Road, Kowloon
 Tel:23489211-4 Fax:(852)2727666

DWG NO. : J856-SD-PW-5102 REV. : C

WINDOW MARK	AW 02
LOCATION	3/F-42/F(4/F,13/F,14/F,24/F,34/F OMITTED) UNIT A2,A5
SECTION	70mm ALUM. SECTION
GLAZING	EGL-1,EGL-1A
QUANTITY	35 Nos./35 Nos.
REMARKS	FACADE(TYPE T1PF02 FOR 3/F~42/F)

WINDOW MARK	AW 02R
LOCATION	3/F-42/F(4/F,13/F,14/F,24/F,34/F OMITTED) UNIT B3
SECTION	70mm ALUM. SECTION
GLAZING	EGL-1,EGL-1A
QUANTITY	35 Nos
REMARKS	FACADE(TYPE T1PF02R FOR 3/F~42/F)

ELEVATION

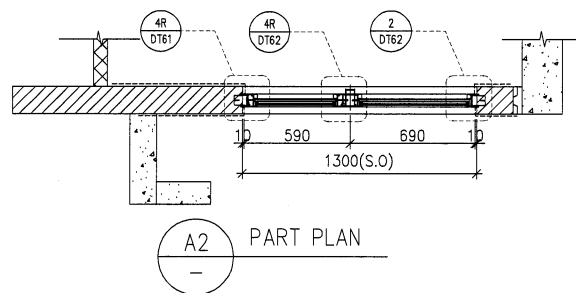
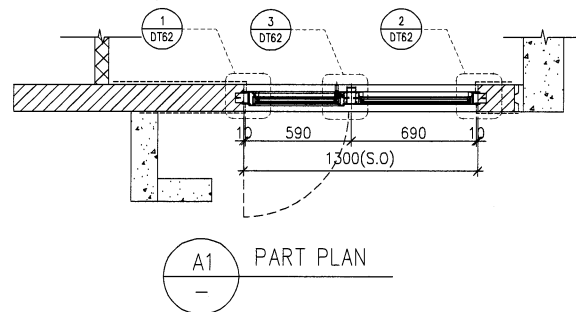
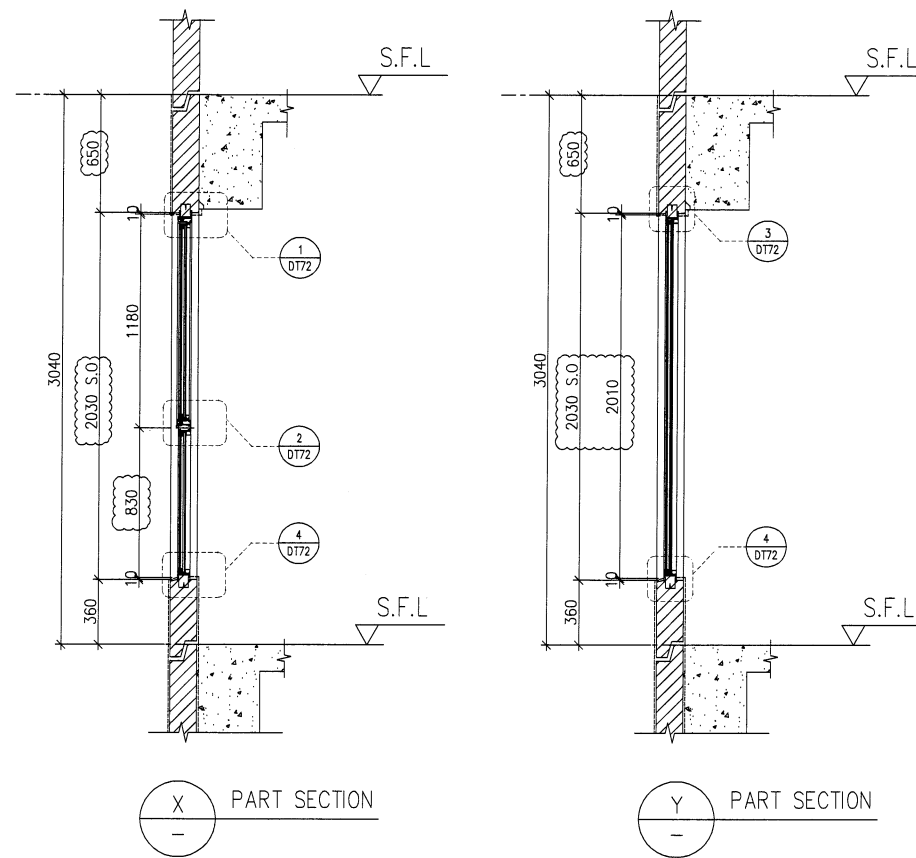
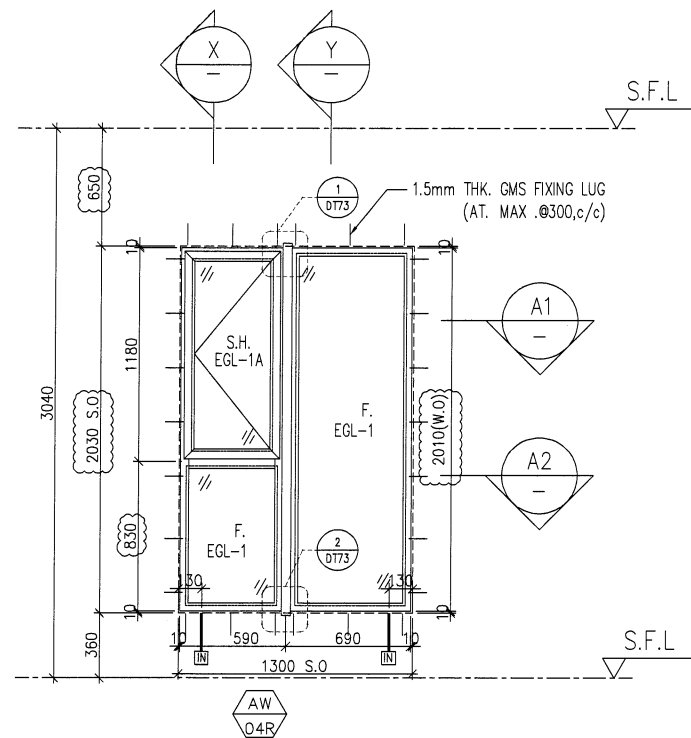

B.D. REF :

CLIENT :

SUN HUNG KAI
REAL ESTATE AGENCY LTD.
42/F SUN HUNG KAI CENTRE, WANCHAI, HONGKONG

ARCHITECT :

Iwk&partners
architects

MAIN CONTRACTOR :

Yee Fai Building Contractors Ltd.

STRUCTURAL ENGINEER :

ARUP

FACADE CONSULTANT:

ALPHA CONSULTING LIMITED
Steel Structure & Facade Specialist

NOTE :

1. ALL DIMENSIONS ARE IN mm.
2. ALL ELEVATIONS ARE VIEWED FROM OUTSIDE.
3. ALL DIMENSIONS TO BE VERIFIED ON SITE BEFORE FABRICATION.

LEGEND :

- (X1) — DETAIL MARK NO.
- (X001) — REFER SHEET NO.

1. F.F.L. — FINISHED FLOOR LEVEL
2. S.F.L. — STRUCTURAL FLOOR LEVEL
3. (R) — REVERSED DETAIL
4. GLASS LEGEND

- EGL-1 — 8mmHS+12mm AIR GAP+10mmTP THK. I.G.U.
- EGL-2 — 10mm THK. CLEAR TEMPERED GLASS
- EGL-4 — 10mm THK. TEMPERED ACID ETCHED GLASS
- EGL-1A — 8mmHS+12mm AIR GAP+8mmTP THK. I.G.U.

NO.	DATE	REVISED	BY
D	17/12/2021	REVISION SUBJECT TO ARCH.COMMENT	Ivan
C	29/11/2021	REVISION SUBJECT TO ARCH.COMMENT	Ivan
B	03/11/2021	REVISION SUBJECT TO ARCH.COMMENT	Ivan
A	12/10/2021	REVISION SUBJECT TO ARCH.COMMENT	Ivan

JOB NO. : J-856

PROJECT :
PROPOSED DEVELOPMENT ABOVE
LIGHT RAIL TIN WING STOP, TSWTL
NO.23, AREA 33, TIN SHUI WAI, N.T.

TITLE :
WINDOW SCHEDULE FOR
TOWER 1 ALUM. WINDOW

DATE : 02-Aug-21 SCALE : 1:40

DRAWN BY : Ivan CHECKED BY :

美特鋁質有限公司
MIDI ALUMINIUM FABRICATOR LTD.
Units 6-8, Sunray Industrial Centre, 1/F
610 Cha Kwo Ling Road, Kowloon
Tel: 23489211-4 Fax: (852) 27727666

DWG NO. : J856-SD-PW-5104 REV. : D

WINDOW MARK	AW D4R
LOCATION	3/F-42/F(4/F,13/F,14/F,24/F,34/F OMITTED) UNIT B2,B6,A3,A7
SECTION	70mm ALUM. SECTION
GLAZING	EGL-1,EGL-1A
QUANTITY	35 Nos / 35 Nos / 35 Nos / 35 Nos
REMARKS	FACADE(TYPE T1PF04R FOR 3/F~42/F)

WINDOW MARK	AW O4
LOCATION	3/F-42/F(4/F,13/F,14/F,24/F,34/F OMITTED) UNIT B7
SECTION	70mm ALUM. SECTION
GLAZING	EGL-1,EGL-1A
QUANTITY	35 Nos
REMARKS	FACADE(TYPE T1PF04 FOR 3/F~42/F)

ELEVATION

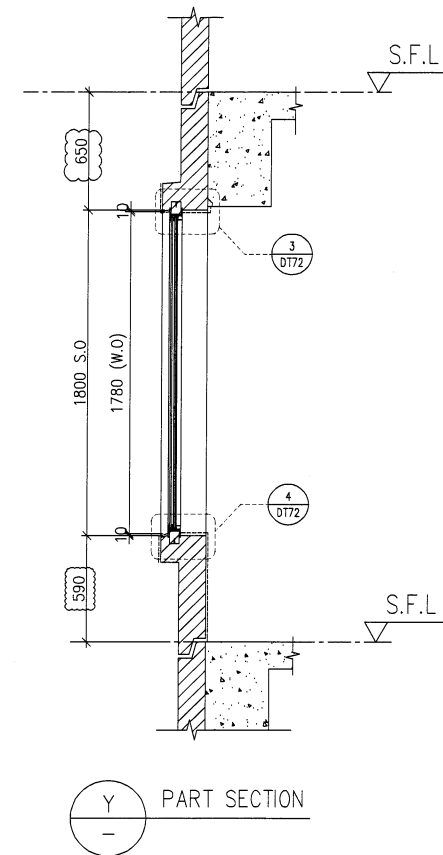
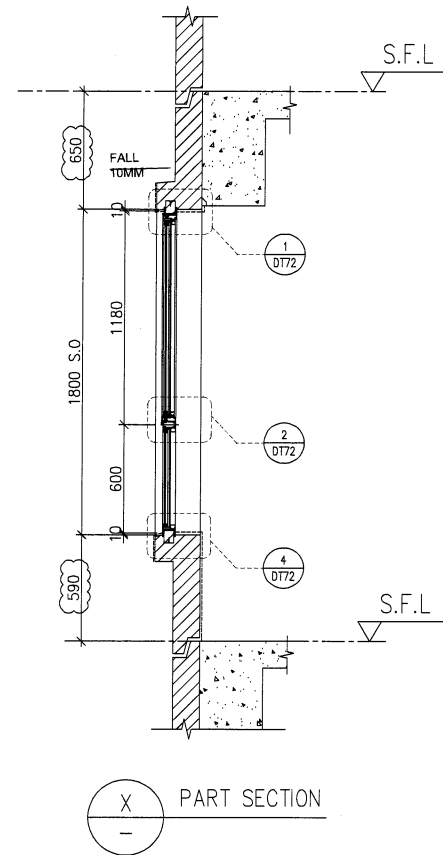
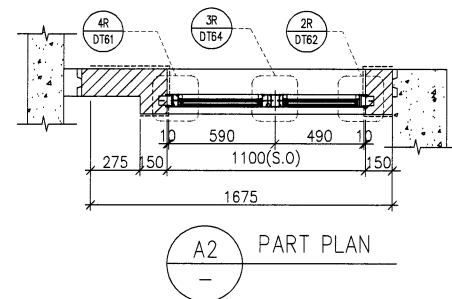
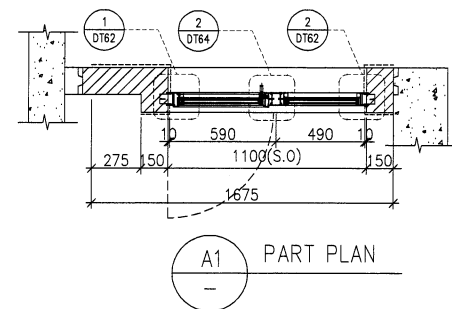
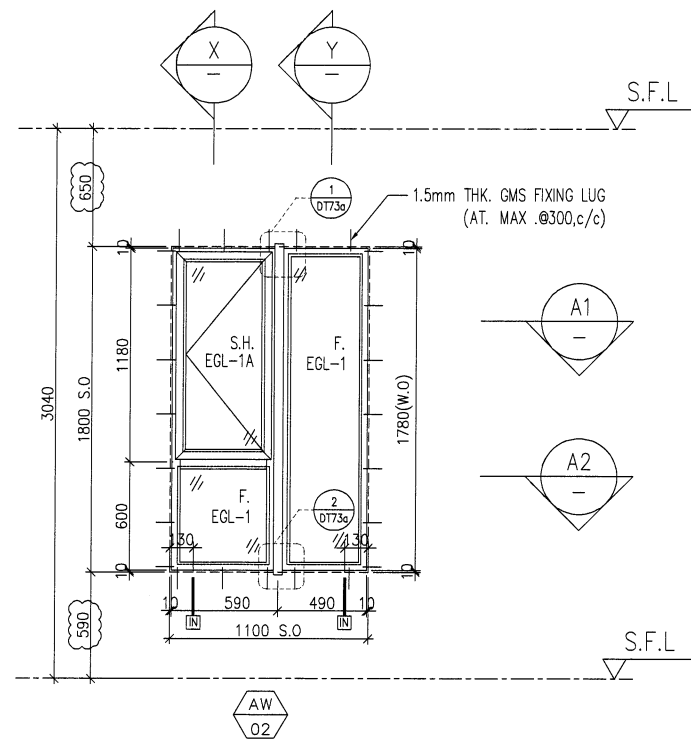

B.D. REF :

CLIENT :
SUN HUNG KAI
 REAL ESTATE AGENCY LTD.
 42/F SUN HUNG KAI CENTRE, WANCHAI, HONGKONG

ARCHITECT :
lwk&partners
 architects

MAIN CONTRACTOR :
Yee Fai Building Contractors Ltd.

STRUCTURAL ENGINEER :
ARUP

FACADE CONSULTANT:
ALPHA CONSULTING LIMITED
 Steel Structure & Facade Specialist

NOTE :
 1. ALL DIMENSIONS ARE IN mm.
 2. ALL ELEVATIONS ARE VIEWED FROM OUTSIDE.
 3. ALL DIMENSIONS TO BE VERIFIED ON SITE BEFORE FABRICATION.

LEGEND :
 X1 — DETAIL MARK NO.
 X001 — REFER SHEET NO.
 1. F.F.L. — FINISHED FLOOR LEVEL
 2. S.F.L. — STRUCTURAL FLOOR LEVEL
 3. (R) — REVERSED DETAIL
 4. GLASS LEGEND
 EGL-1 — 8mmHS+12mm AIR GAP+10mmTP THK. I.G.U.
 EGL-2 — 10mm THK. CLEAR TEMPERED GLASS
 EGL-4 — 10mm THK. TEMPERED ACID ETCHED GLASS
 EGL-1A — 8mmHS+12mm AIR GAP+8mmTP THK. I.G.U.

NO.	DATE	REVISED	BY
C	17/12/2021	REVISION SUBJECT TO ARCH.COMMENT	Ivan
B	29/11/2021	REVISION SUBJECT TO ARCH.COMMENT	Ivan
A	03/11/2021	REVISION SUBJECT TO ARCH.COMMENT	Ivan

JOB NO. : J-856
 PROJECT :
 PROPOSED DEVELOPMENT ABOVE
 LIGHT RAIL TIN WING STOP, TSWTL
 NO.23, AREA 33, TIN SHUI WAI, N.T.

TITLE :
 WINDOW SCHEDULE FOR
 TOWER 1 ALUM. WINDOW

DATE : 02-Aug-21 SCALE : 1:40
 DRAWN BY : Ivan CHECKED BY :
美特鋁質有限公司
MIDI ALUMINIUM FABRICATOR LTD.
 Units 6-8, Sunray Industrial Centre, 1/F
 610 Cha Kwo Ling Road, Kowloon
 Tel: 23489211-4 Fax: (852) 2727666
 DWG NO. : J856-SD-PW-5105 REV. : C

WINDOW MARK	AW 02
LOCATION	3/F-42/F(4/F,13/F,14/F,24/F,34/F OMITTED) UNIT A7,B2
SECTION	70mm ALUM. SECTION
GLAZING	EGL-1,EGL-1A
QUANTITY	35 Nos / 35 Nos
REMARKS	FACADE(TYPE T1PF05R FOR 3/F~42/F)

WINDOW MARK	AW 02R
LOCATION	3/F-42/F(4/F,13/F,14/F,24/F,34/F OMITTED) UNIT A3,A8,B6,B7
SECTION	70mm ALUM. SECTION
GLAZING	EGL-1,EGL-1A
QUANTITY	35 Nos / 35 Nos / 35 Nos / 35 Nos / 35 Nos
REMARKS	FACADE(TYPE T1PF05 FOR 3/F~42/F)

ELEVATION

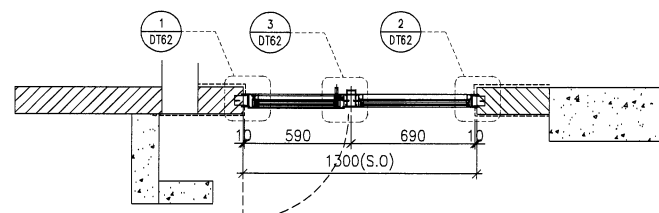
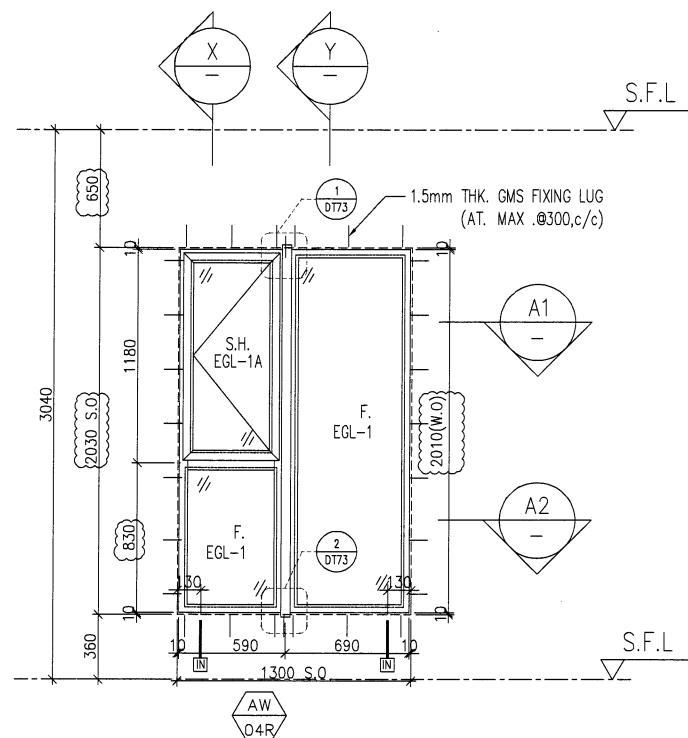

A1 PART PLAN

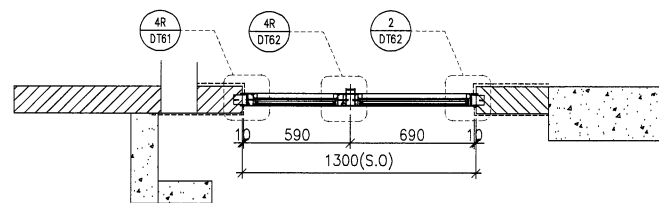

A2 PART PLAN

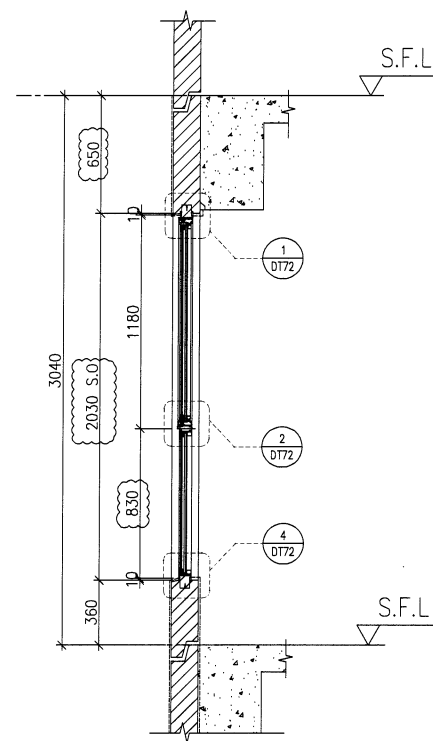

X PART SECTION

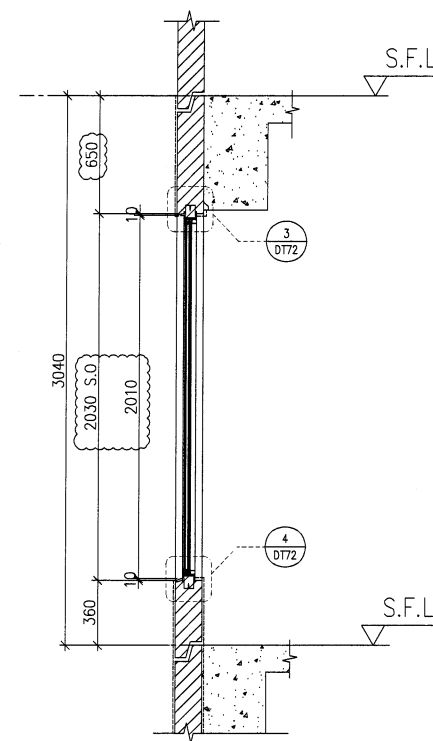

Y PART SECTION

B.D. REF :

CLIENT :
SUN HUNG KAI
 REAL ESTATE AGENCY LTD.
 42/F SUN HUNG KAI CENTRE, WANCHAI, HONGKONG

ARCHITECT :
lwk&partners
 architects

MAIN CONTRACTOR :
怡輝建築有限公司
Yee Fai Building Contractors Ltd.

STRUCTURAL ENGINEER :
ARUP

FACADE CONSULTANT:
ALPHA CONSULTING LIMITED
 Steel Structure & Facade Specialist

NOTE :
 1. ALL DIMENSIONS ARE IN mm.
 2. ALL ELEVATIONS ARE VIEWED FROM OUTSIDE.
 3. ALL DIMENSIONS TO BE VERIFIED ON SITE BEFORE FABRICATION.

LEGEND :
 (X1) — DETAIL MARK NO.
 (X001) — REFER SHEET NO.
 1. F.F.L. — FINISHED FLOOR LEVEL
 2. S.F.L. — STRUCTURAL FLOOR LEVEL
 3. (R) — REVERSED DETAIL
 4. GLASS LEGEND
 EGL-1 — 8mmHS+12mm AIR GAP+10mmTP THK. I.G.U.
 EGL-2 — 10mm THK. CLEAR TEMPERED GLASS
 EGL-4 — 10mm THK. TEMPERED ACID ETCHED GLASS
 EGL-1A — 8mmHS+12mm AIR GAP+8mmTP THK. I.G.U.

NO.	DATE	REVISED	BY
D	17/12/2021	REVISION SUBJECT TO ARCH.COMMENT	ivan
C	29/11/2021	REVISION SUBJECT TO ARCH.COMMENT	ivan
B	03/11/2021	REVISION SUBJECT TO ARCH.COMMENT	ivan
A	12/10/2021	REVISION SUBJECT TO ARCH.COMMENT	ivan

JOB NO. : J-856
 PROJECT :
 PROPOSED DEVELOPMENT ABOVE
 LIGHT RAIL TIN WING STOP, TSWTL
 NO.23, AREA 33, TIN SHUI WAI, N.T.

TITLE :
 WINDOW SCHEDULE FOR
 TOWER 1 ALUM. WINDOW

DATE : 02-Aug-21 SCALE : 1:40
 DRAWN BY : Ivan CHECKED BY :

美特鋁質有限公司
MIDI ALUMINIUM FABRICATOR LTD.
 Units 6-8, Sunray Industrial Centre, 1/F
 610 Cha Kwo Ling Road, Kowloon
 Tel: 23489211-4 Fax: (852) 2727666

DWG NO. : J856-SD-PW-5106 REV. : D

WINDOW MARK	AW 04R
LOCATION	3/F-42/F(4/F,13/F,14/F,24/F,34/F OMITTED) UNIT A5
SECTION	70mm ALUM. SECTION
GLAZING	EGL-1, EGL-1A
QUANTITY	35 Nos
REMARKS	FACADE(TYPE T1PF06R FOR 3/F~42/F)

ELEVATION

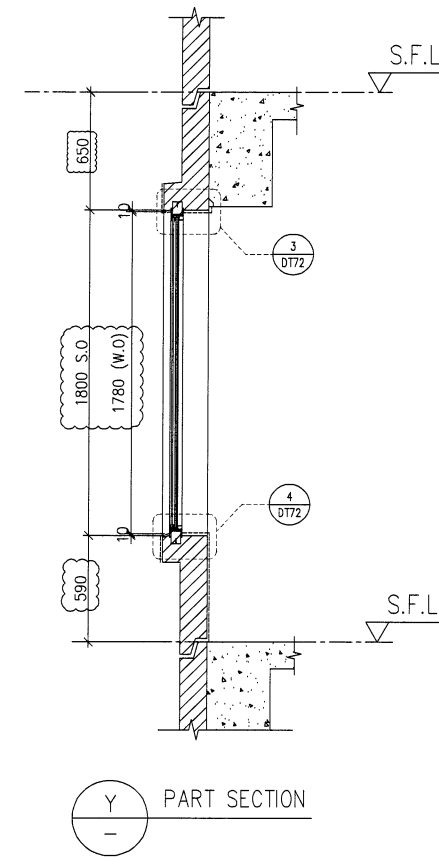
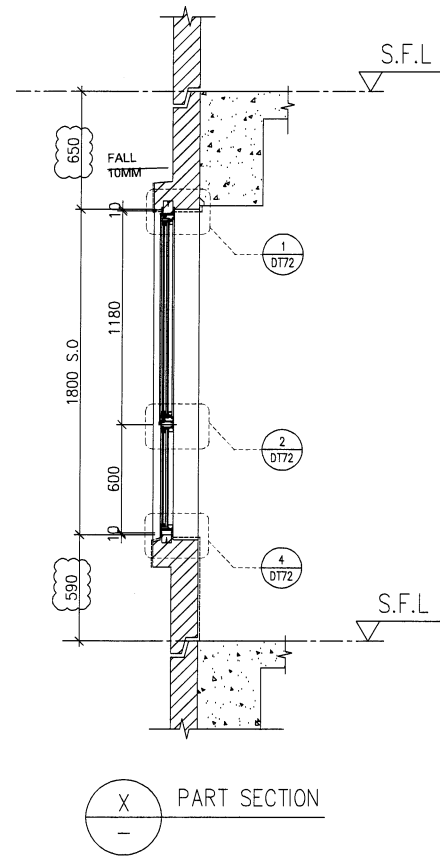
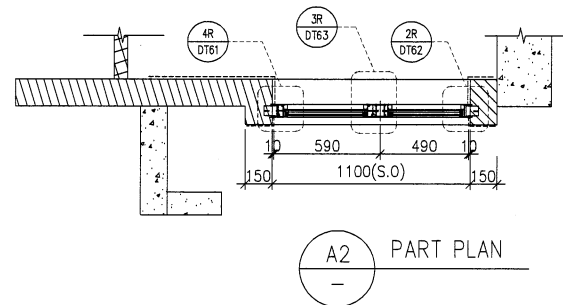
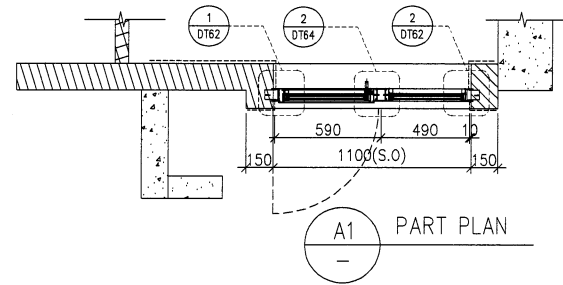
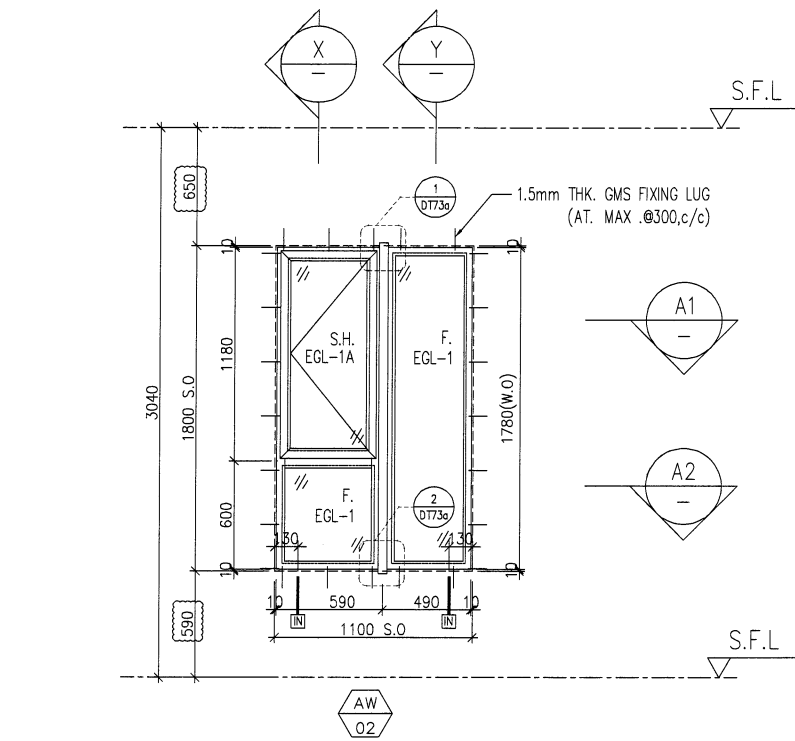

B.D. REF :

CLIENT :
SUN HUNG KAI
 REAL ESTATE AGENCY LTD.
 42/F SUN HUNG KAI CENTRE, WANCHAI, HONGKONG

ARCHITECT :
lwk&partners
 architects

MAIN CONTRACTOR :
怡輝建築有限公司
Yee Fai Building Contractors Ltd.

STRUCTURAL ENGINEER :
ARUP

FACADE CONSULTANT:
ALPHA CONSULTING LIMITED
 Steel Structure & Facade Specialist

NOTE :
 1. ALL DIMENSIONS ARE IN mm.
 2. ALL ELEVATIONS ARE VIEWED FROM OUTSIDE.
 3. ALL DIMENSIONS TO BE VERIFIED ON SITE BEFORE FABRICATION.

LEGEND :
 (X1) — DETAIL MARK NO.
 (X001) — REFER SHEET NO.
 1. F.F.L. — FINISHED FLOOR LEVEL
 2. S.F.L. — STRUCTURAL FLOOR LEVEL
 3. (R) — REVERSED DETAIL
 4. GLASS LEGEND
 EGL-1 — 8mmHS+12mm AIR GAP+10mmTP THK. I.G.U.
 EGL-2 — 10mm THK. CLEAR TEMPERED GLASS
 EGL-4 — 10mm THK. TEMPERED ACID ETCHED GLASS
 EGL-1A — 8mmHS+12mm AIR GAP+8mmTP THK. I.G.U.

NO.	DATE	REVISED	BY
C	17/12/2021	REVISION SUBJECT TO ARCH.COMMENT	ivan
B	29/11/2021	REVISION SUBJECT TO ARCH.COMMENT	ivan
A	03/11/2021	REVISION SUBJECT TO ARCH.COMMENT	ivan

JOB NO. : J-856
 PROJECT :
 PROPOSED DEVELOPMENT ABOVE
 LIGHT RAIL TIN WING STOP, TSWTL
 NO.23, AREA 33, TIN SHUI WAI, N.T.

TITLE :
 WINDOW SCHEDULE FOR
 TOWER 1 ALUM. WINDOW

DATE : 02-Aug-21 SCALE : 1:40

DRAWN BY : Ivan CHECKED BY :

美特鋁質有限公司
MIDI ALUMINIUM FABRICATOR LTD.
 Units 6-8, Sunray Industrial Centre, 1/F
 610 Cha Kwo Ling Road, Kowloon
 Tel: 23489211-4 Fax: (852) 27727666

DWG NO. : J856-SD-PW-5107 REV. : C

WINDOW MARK	AW 02
LOCATION	3/F-42/F(4/F,13/F,14/F,24/F,34/F OMITTED) UNIT B8
SECTION	70mm ALUM. SECTION
GLAZING	EGL-1, EGL-1A
QUANTITY	35 Nos
REMARKS	FACADE(TYPE T1PF08R FOR 3/F~42/F)

WINDOW MARK	AW 02R
LOCATION	3/F-42/F(4/F,13/F,14/F,24/F,34/F OMITTED) UNIT A8,B1
SECTION	70mm ALUM. SECTION
GLAZING	EGL-1, EGL-1A
QUANTITY	35 Nos / 35 Nos
REMARKS	FACADE(TYPE T1PF08 FOR 3/F~42/F)

ELEVATION

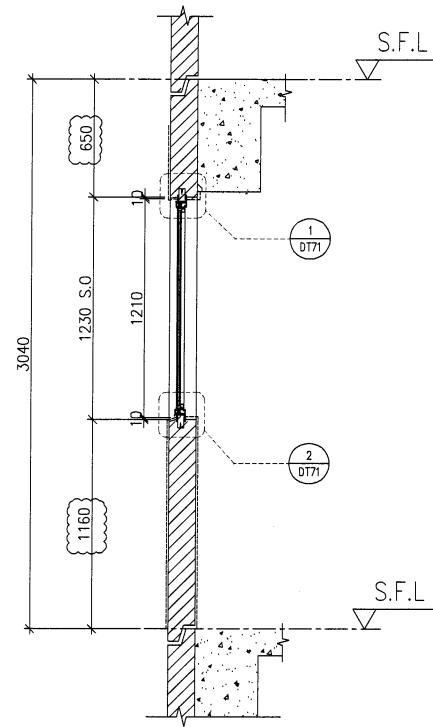
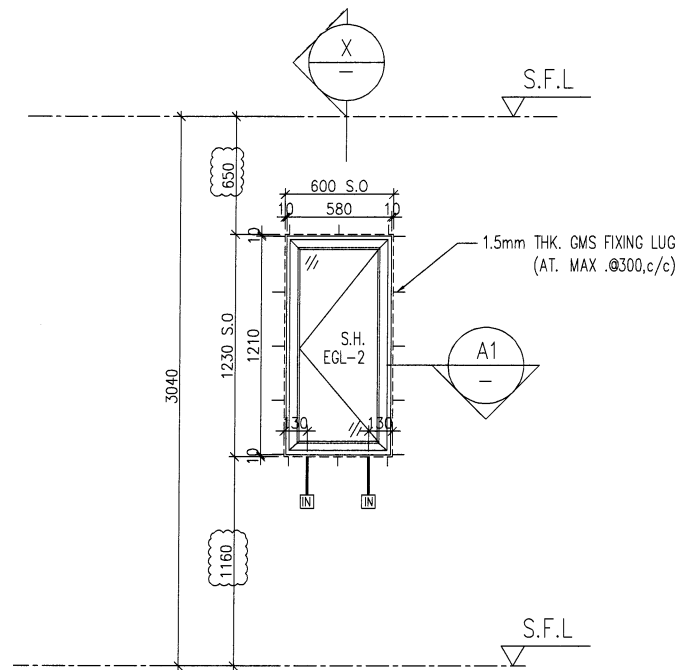

X
—
PART SECTION

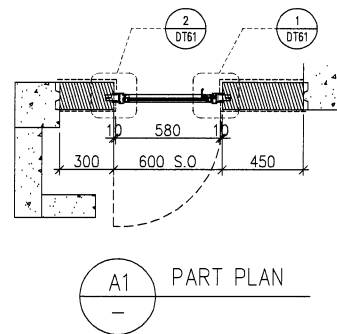

A1
—
PART PLAN

B.D. REF :

CLIENT :

SUN HUNG KAI
REAL ESTATE AGENCY LTD.
42/F SUN HUNG KAI CENTRE, WANCHAI, HONGKONG

ARCHITECT :

lwk&partners
architects

MAIN CONTRACTOR :

Yee Fai Building Contractors Ltd.

STRUCTURAL ENGINEER :

ARUP

FACADE CONSULTANT:

ALPHA CONSULTING LIMITED
Steel Structure & Facade Specialist

NOTE :

1. ALL DIMENSIONS ARE IN mm.
2. ALL ELEVATIONS ARE VIEWED FROM OUTSIDE.
3. ALL DIMENSIONS TO BE VERIFIED ON SITE BEFORE FABRICATION.

LEGEND :

- (X1) — DETAIL MARK NO.
- (X001) — REFER SHEET NO.

1. F.F.L. — FINISHED FLOOR LEVEL
2. S.F.L. — STRUCTURAL FLOOR LEVEL
3. (R) — REVERSED DETAIL
4. GLASS LEGEND

EGL-1—8mmHS+12mm AIR GAP+10mmTP THK. I.G.U.
EGL-2—10mm THK. CLEAR TEMPERED GLASS
EGL-4—10mm THK. TEMPERED ACID ETCHED GLASS
EGL-1A—8mmHS+12mm AIR GAP+8mmTP THK. I.G.U.

NO.	DATE	REVISION	REVISED	BY
C	17/12/2021	REVISION SUBJECT TO ARCH.COMMENT		Ivan
B	29/11/2021	REVISION SUBJECT TO ARCH.COMMENT		Ivan
A	03/11/2021	REVISION SUBJECT TO ARCH.COMMENT		Ivan

JOB NO. : J-856

PROJECT :
PROPOSED DEVELOPMENT ABOVE
LIGHT RAIL TIN WING STOP, TSWTL
NO.23, AREA 33, TIN SHUI WAI, N.T.

TITLE :
WINDOW SCHEDULE FOR
TOWER 1 ALUM. WINDOW

DATE : 02-Aug-21 SCALE : 1:40

DRAWN BY : Ivan CHECKED BY :

美特鋁質有限公司
MIDI ALUMINIUM FABRICATOR LTD.
Units 6-8, Sunray Industrial Centre, 1/F
610 Cha Kwo Ling Road, Kowloon
Tel:23489211-4 Fax:(852)27727666

DWG NO. : J856-SD-PW-5108 REV. : C

WINDOW MARK	AW 06
LOCATION	3/F-42/F(4/F,13/F,14/F,24/F,34/F OMITTED) UNIT B3
SECTION	50mm ALUM. SECTION
GLAZING	EGL-2
QUANTITY	35 Nos
REMARKS	FACADE(TYPE T1PF09 FOR 3/F~42/F)

ELEVATION

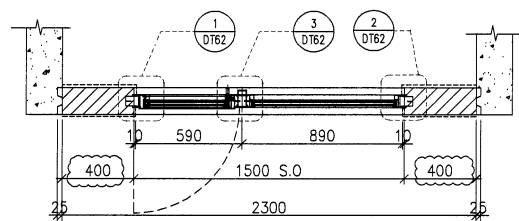
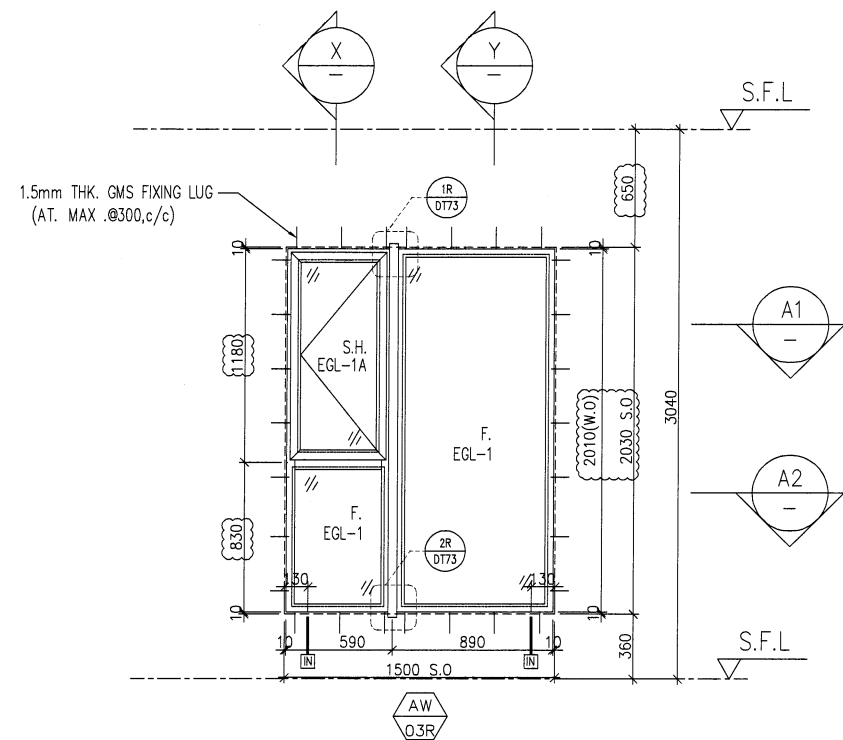

A1 PART PLAN

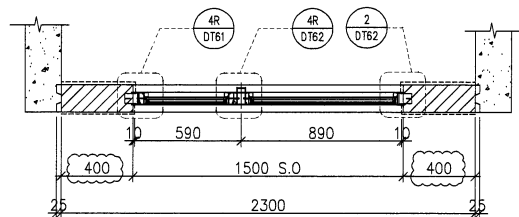

A2 PART PLAN

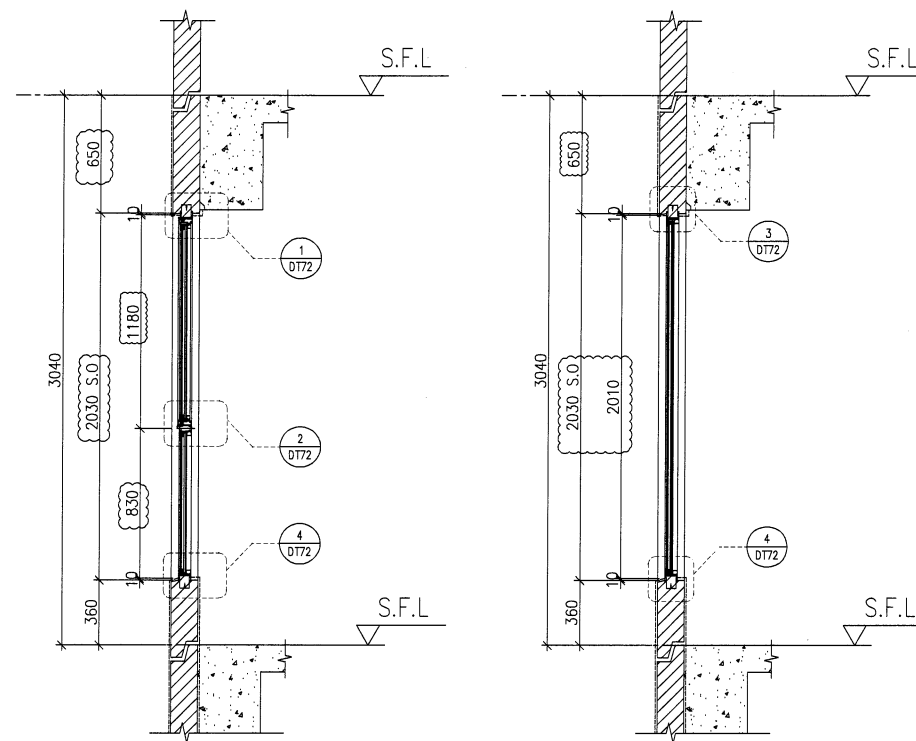

X PART SECTION

Y PART SECTION

B.D. REF :

CLIENT :
SUN HUNG KAI
 REAL ESTATE AGENCY LTD.
 42/F SUN HUNG KAI CENTRE, WANCHAI, HONGKONG

ARCHITECT :
lwk&partners
 architects

MAIN CONTRACTOR :
Yee Fai Building Contractors Ltd.

STRUCTURAL ENGINEER :
ARUP

FACADE CONSULTANT:
ALPHA CONSULTING LIMITED
 Steel Structure & Facade Specialist

NOTE :
 1. ALL DIMENSIONS ARE IN mm.
 2. ALL ELEVATIONS ARE VIEWED FROM OUTSIDE.
 3. ALL DIMENSIONS TO BE VERIFIED ON SITE BEFORE FABRICATION.

LEGEND :
 X1 --- DETAIL MARK NO.
 X001 --- REFER SHEET NO.

1. F.F.L. --- FINISHED FLOOR LEVEL
 2. S.F.L. --- STRUCTURAL FLOOR LEVEL
 3. (R) --- REVERSED DETAIL
 4. GLASS LEGEND
 EGL-1--8mmHS+12mm AIR GAP+10mmTP THK. I.G.U.
 EGL-2--10mm THK. CLEAR TEMPERED GLASS
 EGL-4--10mm THK. TEMPERED ACID ETCHED GLASS
 EGL-1A--8mmHS+12mm AIR GAP+8mmTP THK. I.G.U.

NO.	DATE	REVISED	BY
D	17/12/2021	REVISION SUBJECT TO ARCH.COMMENT	Ivan
C	29/11/2021	REVISION SUBJECT TO ARCH.COMMENT	Ivan
B	03/11/2021	REVISION SUBJECT TO ARCH.COMMENT	Ivan
A	12/10/2021	REVISION SUBJECT TO ARCH.COMMENT	Ivan

JOB NO. : J-856
 PROJECT : PROPOSED DEVELOPMENT ABOVE LIGHT RAIL TIN WING STOP, TSWTL NO.23, AREA 33, TIN SHUI WAI, N.T.

TITLE : WINDOW SCHEDULE FOR TOWER 1 ALUM. WINDOW

DATE : 02-Aug-21 SCALE : 1:40
 DRAWN BY : Ivan CHECKED BY :

美特鋁質有限公司
MIDI ALUMINIUM FABRICATOR LTD.
 Units 6-8, Sunray Industrial Centre, 1/F
 610 Cha Kwo Ling Road, Kowloon
 Tel:23489211-4 Fax:(852)27727666

DWG NO. : J856-SD-PW-5109 REV. : D

WINDOW MARK	AW 03R
LOCATION	3/F-42/F(4/F,13/F,14/F,24/F,34/F OMITTED) UNIT B3
SECTION	70mm ALUM. SECTION
GLAZING	EGL-1,EGL-1A
QUANTITY	35 Nos
REMARKS	FACADE(TYPE T1PF10 FOR 3/F~42/F)

ELEVATION

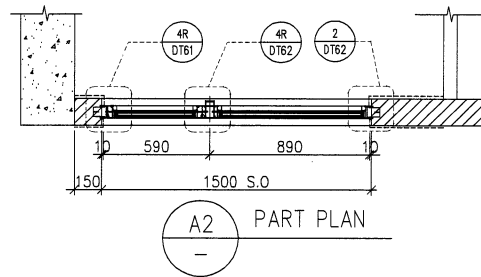
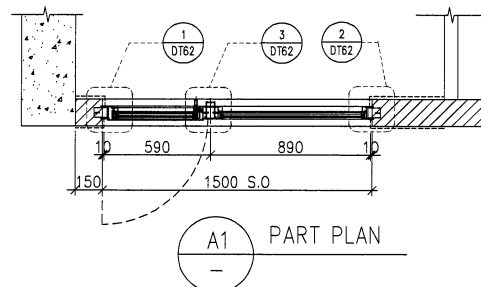
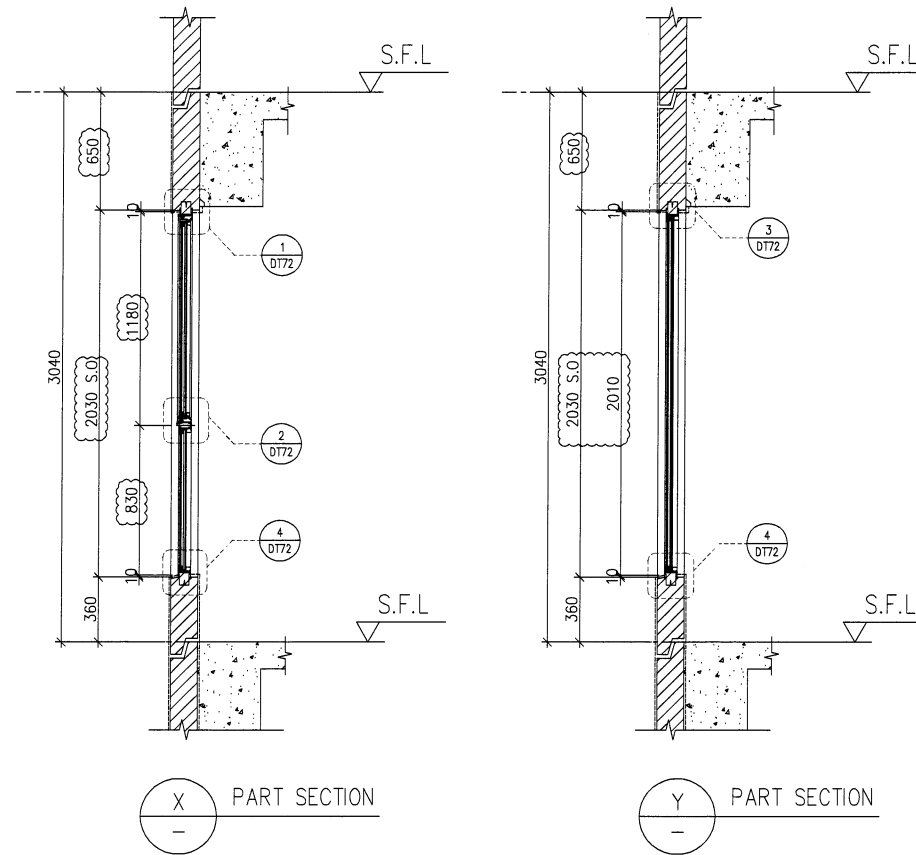
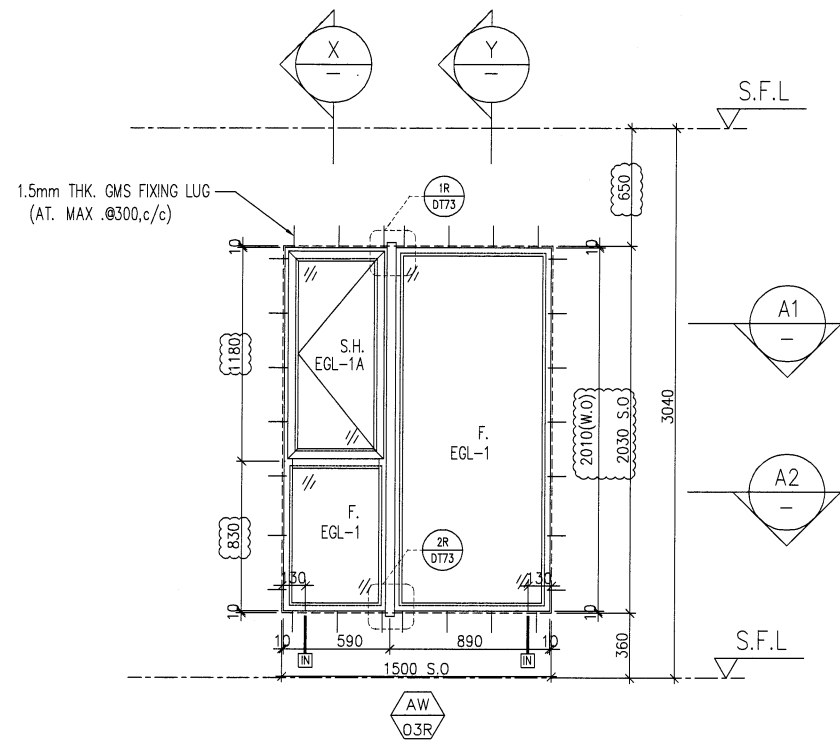

B.D. REF :

CLIENT :
SUN HUNG KAI
 REAL ESTATE AGENCY LTD.
 42/F SUN HUNG KAI CENTRE, WANCHAI, HONGKONG

ARCHITECT :
lwk&partners
 architects

MAIN CONTRACTOR :
Yee Fai Building Contractors Ltd.

STRUCTURAL ENGINEER :
ARUP

FACADE CONSULTANT:
ALPHA CONSULTING LIMITED
 Steel Structure & Facade Specialist

NOTE :
 1. ALL DIMENSIONS ARE IN mm.
 2. ALL ELEVATIONS ARE VIEWED FROM OUTSIDE.
 3. ALL DIMENSIONS TO BE VERIFIED ON SITE BEFORE FABRICATION.

LEGEND :
 X1 — DETAIL MARK NO.
 X001 — REFER SHEET NO.

1. F.F.L. — FINISHED FLOOR LEVEL
 2. S.F.L. — STRUCTURAL FLOOR LEVEL
 3. (R) — REVERSED DETAIL
 4. GLASS LEGEND
 EGL-1 — 8mmHS+12mm AIR GAP+10mmTP THK. I.G.U.
 EGL-2 — 10mm THK. CLEAR TEMPERED GLASS
 EGL-4 — 10mm THK. TEMPERED ACID ETCHED GLASS
 EGL-1A — 8mmHS+12mm AIR GAP+8mmTP THK. I.G.U.

D	17/12/2021	REVISION SUBJECT TO ARCH.COMMENT	ivan
C	29/11/2021	REVISION SUBJECT TO ARCH.COMMENT	ivan
B	03/11/2021	REVISION SUBJECT TO ARCH.COMMENT	ivan
A	12/10/2021	REVISION SUBJECT TO ARCH.COMMENT	ivan
NO.	DATE	REVISED	BY

JOB NO. : J-856
 PROJECT : PROPOSED DEVELOPMENT ABOVE LIGHT RAIL TIN WING STOP, TSWTL NO.23, AREA 33, TIN SHUI WAI, N.T.

TITLE : WINDOW SCHEDULE FOR TOWER 1 ALUM. WINDOW

DATE : 02-Aug-21 SCALE : 1:40
 DRAWN BY : Ivan CHECKED BY :

英特銘質有限公司
MIDI ALUMINIUM FABRICATOR LTD.
 Units 6-8, Sunray Industrial Centre, 1/F
 610 Cha Kwo Ling Road, Kowloon
 Tel: 23489211-4 Fax: (852) 2727666

DWG NO. : J856-SD-PW-5110 REV. : D

WINDOW MARK	AW 0.3R
LOCATION	3/F-42/F(4/F,13/F,14/F,24/F,34/F OMITTED) UNIT B5
SECTION	70mm ALUM. SECTION
GLAZING	EGL-1,EGL-1A
QUANTITY	35 Nos
REMARKS	FACADE(TYPE T1PF11R FOR 3/F~42/F)

ELEVATION

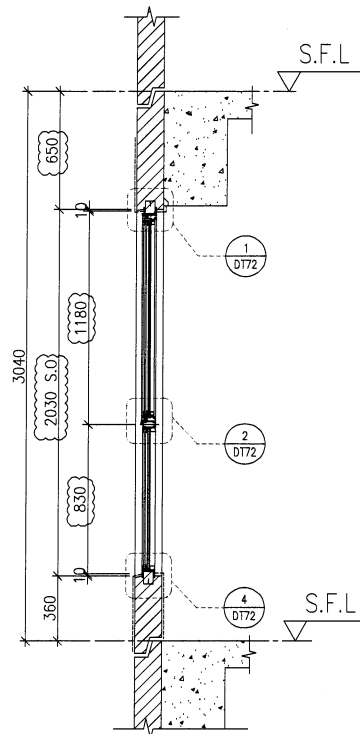
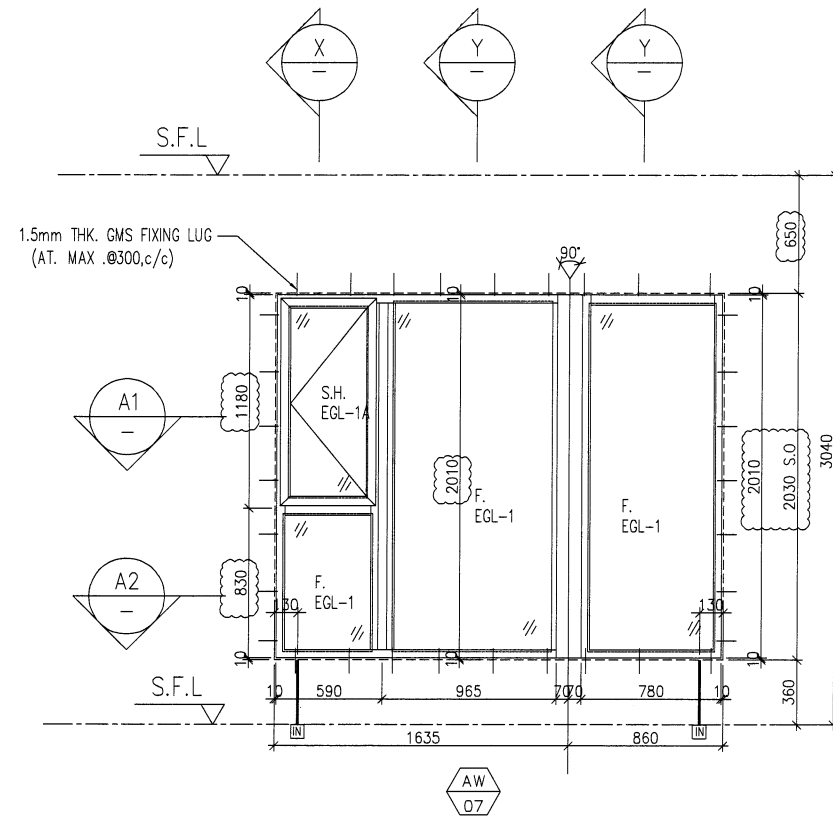

X PART SECTION

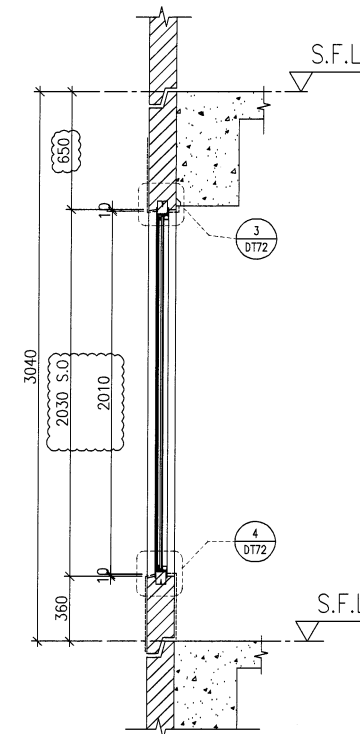

Y PART SECTION

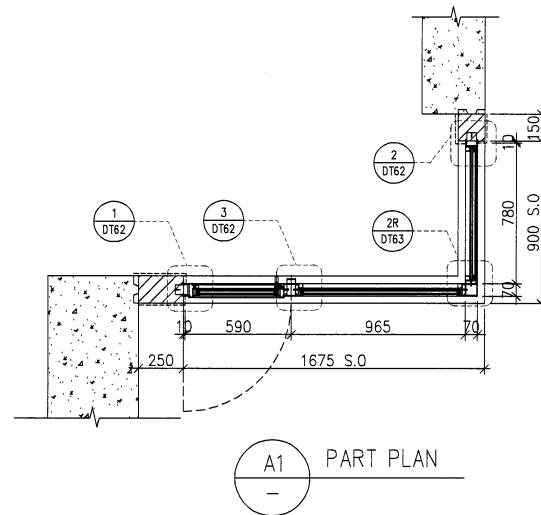

A1 PART PLAN

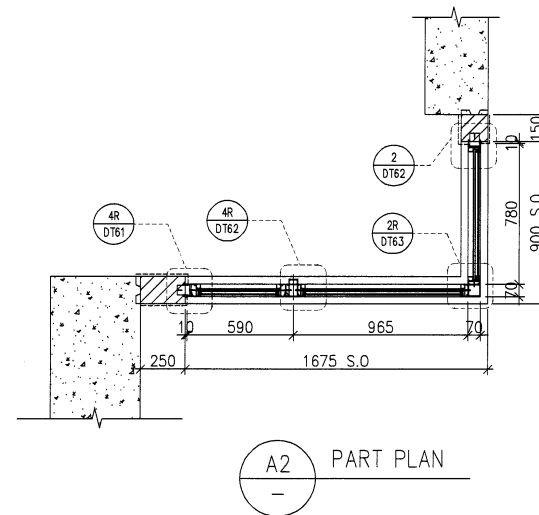

A2 PART PLAN

B.D. REF :

CLIENT :
SUN HUNG KAI
 REAL ESTATE AGENCY LTD.
 42/F SUN HUNG KAI CENTRE, WANCHAI, HONGKONG

ARCHITECT :
lwk&partners
 architects

MAIN CONTRACTOR :
Yee Fai Building Contractors Ltd.

STRUCTURAL ENGINEER :
ARUP

FACADE CONSULTANT:
ALPHA CONSULTING LIMITED
 Steel Structure & Facade Specialist

NOTE :
 1. ALL DIMENSIONS ARE IN mm.
 2. ALL ELEVATIONS ARE VIEWED FROM OUTSIDE.
 3. ALL DIMENSIONS TO BE VERIFIED ON SITE BEFORE FABRICATION.

LEGEND :
 X1 — DETAIL MARK NO.
 X001 — REFER SHEET NO.
 1. F.F.L. — FINISHED FLOOR LEVEL
 2. S.F.L. — STRUCTURAL FLOOR LEVEL
 3. (B) — REVERSED DETAIL
 4. GLASS LEGEND
 EGL-1 — 8mmHS+12mm AIR GAP+10mmTP THK. I.G.U.
 EGL-2 — 10mm THK. CLEAR TEMPERED GLASS
 EGL-4 — 10mm THK. TEMPERED ACID ETCHED GLASS
 EGL-1A — 8mmHS+12mm AIR GAP+8mmTP THK. I.G.U.

NO.	DATE	REVISION	BY
D	17/12/2021	REVISION SUBJECT TO ARCH.COMMENT	ivan
C	29/11/2021	REVISION SUBJECT TO ARCH.COMMENT	ivan
B	03/11/2021	REVISION SUBJECT TO ARCH.COMMENT	ivan
A	12/10/2021	REVISION SUBJECT TO ARCH.COMMENT	ivan

JOB NO. : J-856
 PROJECT : PROPOSED DEVELOPMENT ABOVE LIGHT RAIL TIN WING STOP, TSWTL NO.23, AREA 33, TIN SHUI WAI, N.T.

TITLE : WINDOW SCHEDULE FOR TOWER 1 ALUM. WINDOW

DATE : 02-Aug-21 SCALE : 1:40
 DRAWN BY : Ivan CHECKED BY :

美特鋁質有限公司
MIDI ALUMINIUM FABRICATOR LTD.
 Units 6-8, Sunray Industrial Centre, 1/F
 610 Cha Kwo Ling Road, Kowloon
 Tel:23489211-4 Fax:(852)2727666

WINDOW MARK	AW 07
LOCATION	3/F-42/F(4/F,13/F,14/F,24/F,34/F OMITTED) UNIT B8
SECTION	70mm ALUM. SECTION
GLAZING	EGL-1,EGL-1A
QUANTITY	35 Nos
REMARKS	FACADE(TYPE T1PF12 FOR 3/F~42/F)

DWG NO. : J856-SD-PW-5111 REV. : D

ELEVATION

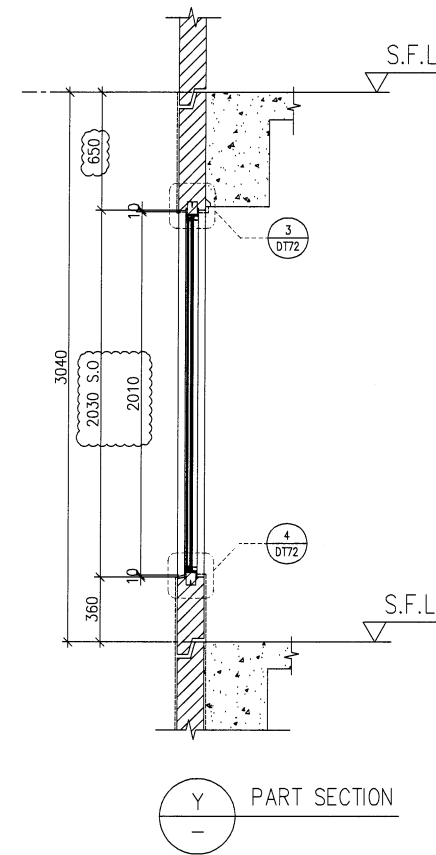
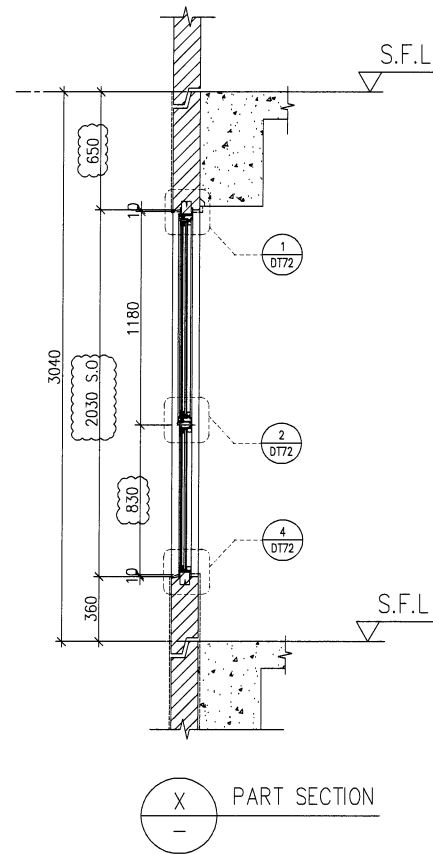
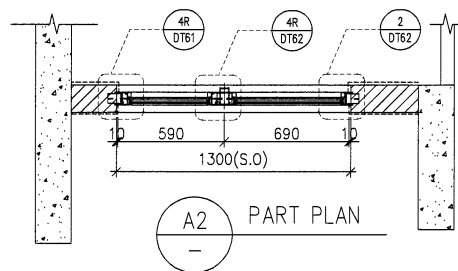
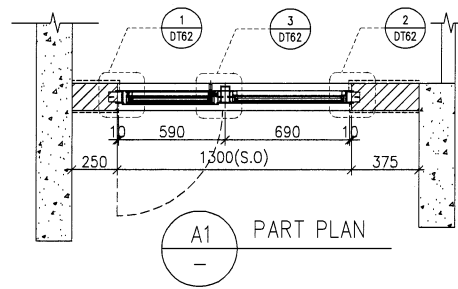
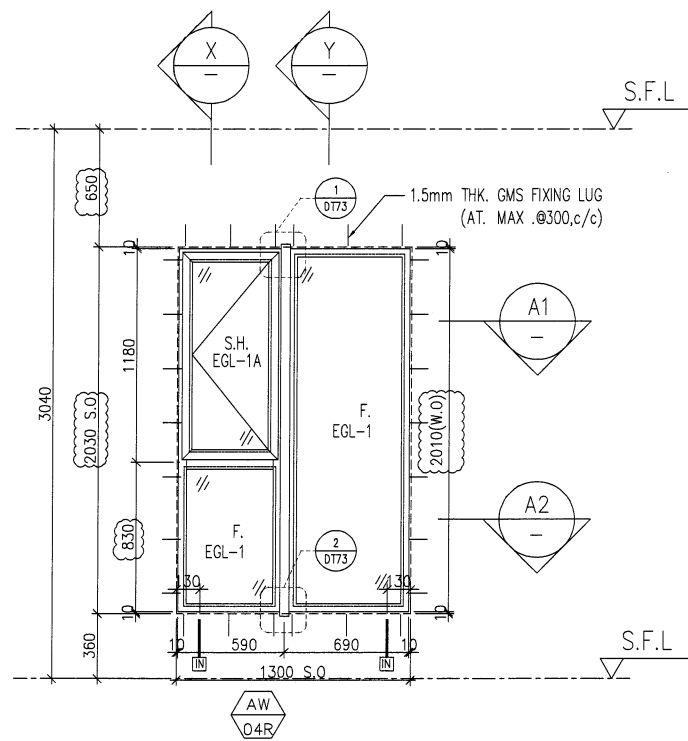

B.D. REF :

CLIENT :

SUN HUNG KAI
REAL ESTATE AGENCY LTD.
42/F SUN HUNG KAI CENTRE, WANCHAI, HONGKONG

ARCHITECT :

lwk&partners
architects

MAIN CONTRACTOR :

Yee Fal Building Contractors Ltd.

STRUCTURAL ENGINEER :

ARUP

FACADE CONSULTANT:

ALPHA CONSULTING LIMITED
Steel Structure & Facade Specialist

NOTE :

1. ALL DIMENSIONS ARE IN mm.
2. ALL ELEVATIONS ARE VIEWED FROM OUTSIDE.
3. ALL DIMENSIONS TO BE VERIFIED ON SITE BEFORE FABRICATION.

LEGEND :

- x1 — DETAIL MARK NO.
- x001 — REFER SHEET NO.

1. F.F.L. — FINISHED FLOOR LEVEL
2. S.F.L. — STRUCTURAL FLOOR LEVEL
3. (R) — REVERSED DETAIL
4. GLASS LEGEND

EGL-1—8mmHS+12mm AIR GAP+10mmTP THK. I.G.U.
EGL-2—10mm THK. CLEAR TEMPERED GLASS
EGL-4—10mm THK. TEMPERED ACID ETCHED GLASS
EGL-1A—8mmHS+12mm AIR GAP+8mmTP THK. I.G.U.

B	21/12/2021	REVISION SUBJECT TO ARCH.COMMENT	lvon
A	12/10/2021	REVISION SUBJECT TO ARCH.COMMENT	lvon
NO.	DATE	REVISED	BY

JOB NO. : J-856

PROJECT :
PROPOSED DEVELOPMENT ABOVE
LIGHT RAIL TIN WING STOP, TSWTL
NO.23, AREA 33, TIN SHUI WAI, N.T.

TITLE :
WINDOW SCHEDULE FOR
TOWER 1 ALUM. WINDOW

DATE : 02-Aug-21 SCALE : 1:40

DRAWN BY : lvon CHECKED BY :

美特铝质有限公司
MIDI ALUMINIUM FABRICATOR LTD.
Units 6-8, Sunray Industrial Centre, 1/F
610 Cho Kwo Ling Road, Kowloon
Tel: 23489211-4 Fax: (852) 27727666

DWG NO. : J856-SD-PW-5112 REV. : B

WINDOW MARK	AW 04R
LOCATION	3/F-42/F(4/F,13/F,14/F,24/F,34/F OMITTED) UNIT A6
SECTION	70mm ALUM. SECTION
GLAZING	EGL-1, EGL-1A
QUANTITY	35 Nos
REMARKS	FACADE(TYPE T1PF06R FOR 3/F~42/F)

ELEVATION

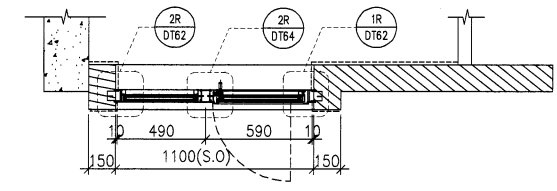
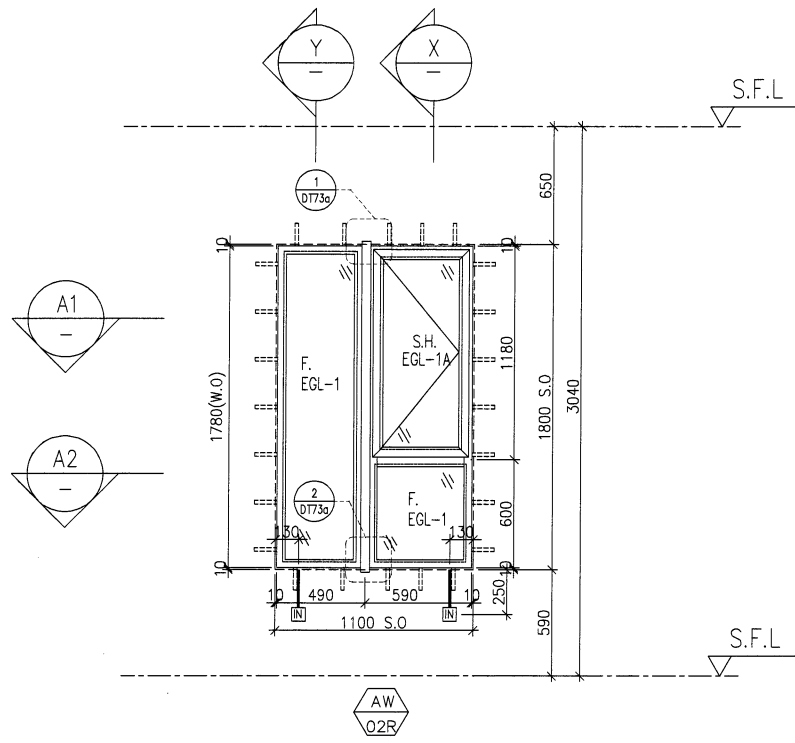

A1 PART PLAN

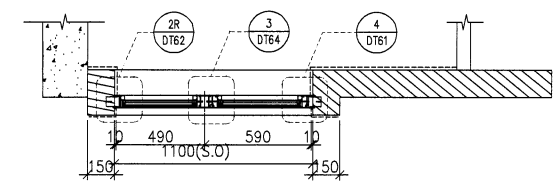

A2 PART PLAN

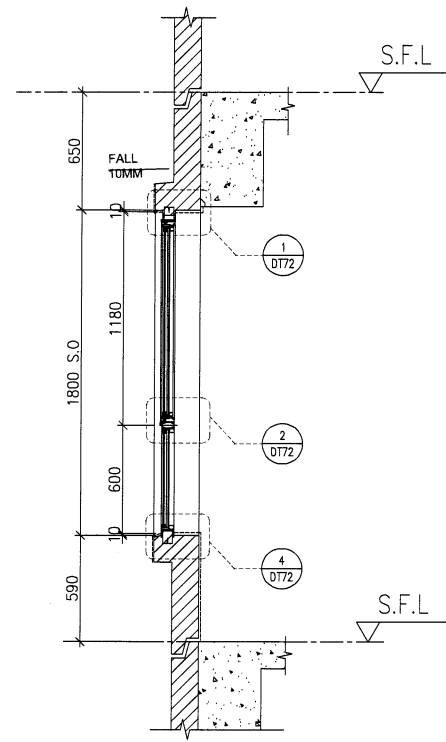

X PART SECTION

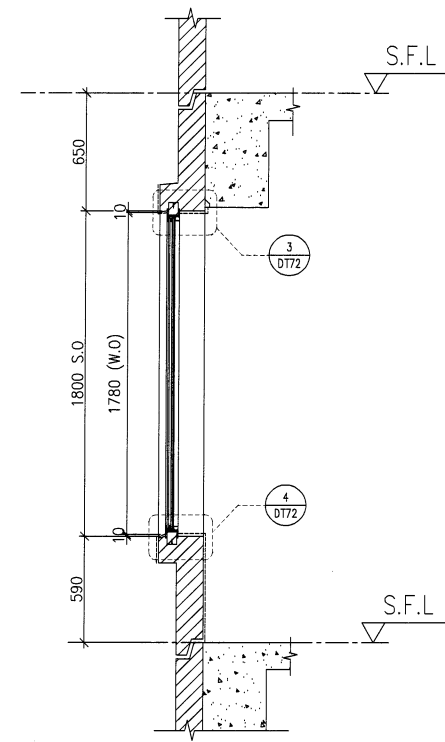

Y PART SECTION

FACADE CODE		
LWK	鴻輝	UNIT
PF-01R	T2PF-10	A1

WINDOW MARK	AW O2R
LOCATION	3/F-42/F(4/F,13/F,14/F,24/F,34/F OMITTED) UNIT A1
SECTION	70mm ALUM. SECTION
GLAZING	EGL-1,EGL-1A
QUANTITY	35 Nos.
REMARKS	FACADE(TYPE T2PF01R FOR 3/F~42/F)

B.D. REF :

CLIENT :
SUN HUNG KAI
 REAL ESTATE AGENCY LTD.
 42/F SUN HUNG KAI CENTRE, WANCHAI, HONGKONG

ARCHITECT :
lwk&partners
 architects

MAIN CONTRACTOR :
Yee Fal Building Contractors Ltd.

STRUCTURAL ENGINEER :
ARUP

FACADE CONSULTANT:
ALPHA CONSULTING LIMITED
 Steel Structure & Facade Specialist

NOTE :
 1. ALL DIMENSIONS ARE IN mm.
 2. ALL ELEVATIONS ARE VIEWED FROM OUTSIDE.
 3. ALL DIMENSIONS TO BE VERIFIED ON SITE BEFORE FABRICATION.

LEGEND :
 (X1) — DETAIL MARK NO.
 (X001) — REFER SHEET NO.
 1. F.F.L. — FINISHED FLOOR LEVEL
 2. S.F.L. — STRUCTURAL FLOOR LEVEL
 3. (R) — REVERSED DETAIL
 4. GLASS LEGEND
 EGL-1 — 8mmHS+12mm AIR GAP+10mmTP THK. I.G.U.
 EGL-2 — 10mm THK. CLEAR TEMPERED GLASS
 EGL-4 — 10mm THK. TEMPERED ACID ETCHED GLASS
 EGL-1A — 8mmHS+12mm AIR GAP+8mmTP THK. I.G.U.

NO.	DATE	REVISED	BY
F	18/05/2022	REVISION SUBJECT TO ARCH.COMMENT	Ivan
E	08/04/2022	REVISION SUBJECT TO ARCH.COMMENT	Ivan
D	17/12/2021	REVISION SUBJECT TO ARCH.COMMENT	Ivan
C	29/11/2021	REVISION SUBJECT TO ARCH.COMMENT	Ivan
B	03/11/2021	REVISION SUBJECT TO ARCH.COMMENT	Ivan
A	12/10/2021	REVISION SUBJECT TO ARCH.COMMENT	Ivan

JOB NO. : J-856
 PROJECT : PROPOSED DEVELOPMENT ABOVE LIGHT RAIL TIN WING STOP, TSWTL NO.23, AREA 33, TIN SHUI WAI, N.T.

TITLE : WINDOW SCHEDULE FOR TOWER 2 ALUM. WINDOW

DATE : 02-Aug-21 SCALE : 1:40
 DRAWN BY : Ivan CHECKED BY :

美特鋁質有限公司
MIDI ALUMINUM FABRICATOR LTD.
 Units 6-8, Sunray Industrial Centre, 1/F
 510 Cha Kwo Ling Road, Kowloon
 Tel:23489211-4 Fax:(852)27727666
 DWG NO. : J856-SD-PW-5201 REV. : F

ELEVATION

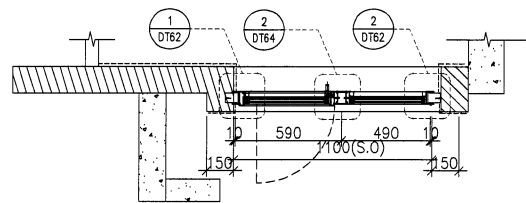
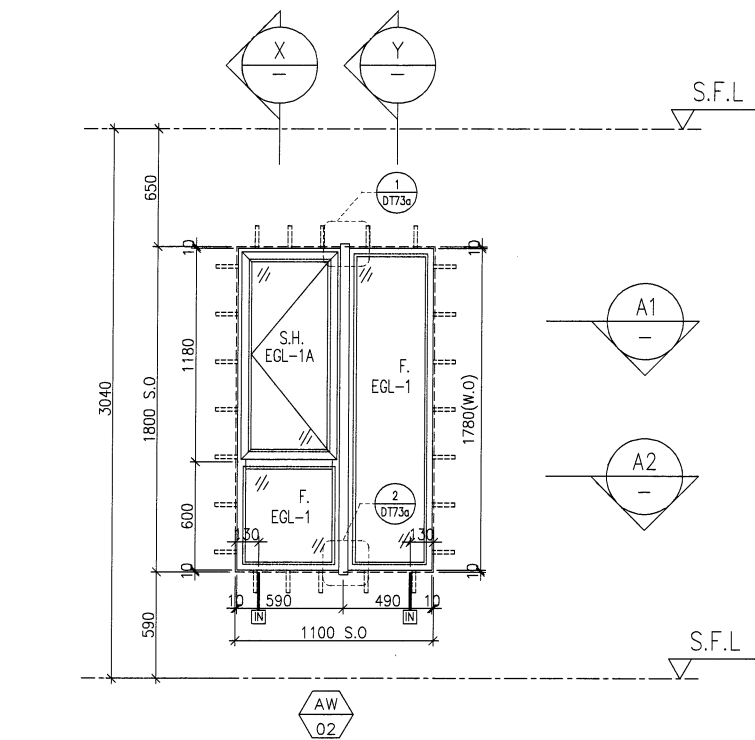

A1 PART PLAN

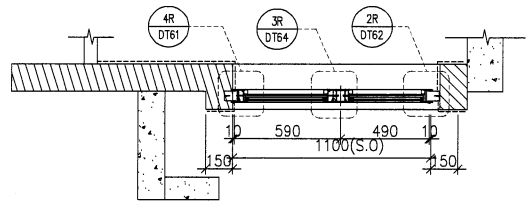

A2 PART PLAN

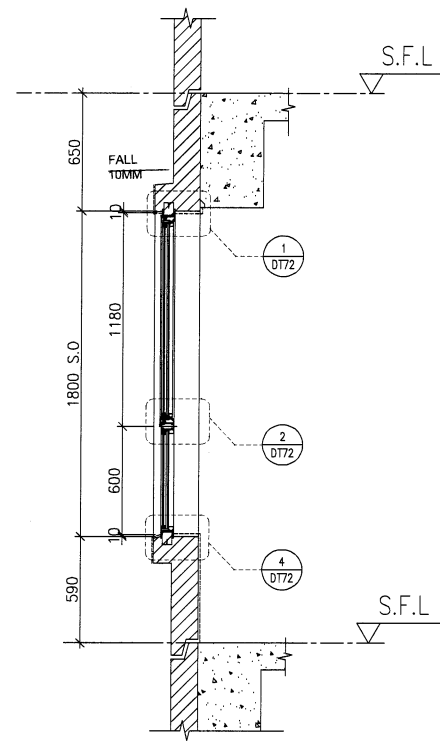

X PART SECTION

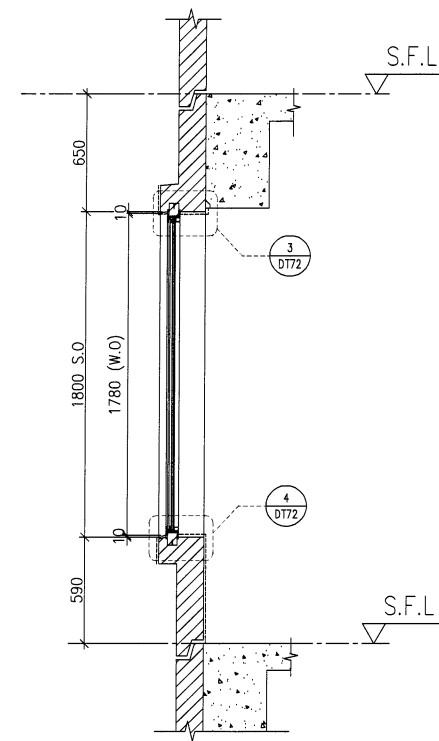

Y PART SECTION

FACADE CODE		
LWK	鴻輝	UNIT
PF-02	T2PF-09	A2
PF-02R	T2PF-18	A5

WINDOW MARK	AW 02	AW 02R
LOCATION	3/F-42/F(4/F,13/F,14/F,24/F,34/F OMITTED) UNIT A2	3/F-42/F(4/F,13/F,14/F,24/F,34/F OMITTED) UNIT A5
SECTION	70mm ALUM. SECTION	70mm ALUM. SECTION
GLAZING	EGL-1,EGL-1A	EGL-1,EGL-1A
QUANTITY	35 Nos.	35 Nos
REMARKS	FACADE(TYPE T2PF02 FOR 3/F~42/F)	FACADE(TYPE T2PF02R FOR 3/F~42/F)

B.D. REF :

CLIENT :
SUN HUNG KAI
 REAL ESTATE AGENCY LTD.
 42/F SUN HUNG KAI CENTRE, WANCHAI, HONGKONG

ARCHITECT :
lwk&partners
 architects

MAIN CONTRACTOR :
Yee Fal 怡輝建築有限公司
 Building Contractors Ltd.

STRUCTURAL ENGINEER :
ARUP

FACADE CONSULTANT:
ALPHA CONSULTING LIMITED
 Steel Structure & Facade Specialist

NOTE:
 1. ALL DIMENSIONS ARE IN mm.
 2. ALL ELEVATIONS ARE VIEWED FROM OUTSIDE.
 3. ALL DIMENSIONS TO BE VERIFIED ON SITE BEFORE FABRICATION.

LEGEND:
 X1 - DETAIL MARK NO.
 X001 - REFER SHEET NO.
 1. F.F.L. -- FINISHED FLOOR LEVEL
 2. S.F.L. -- STRUCTURAL FLOOR LEVEL
 3. (R) -- REVERSED DETAIL
 4. GLASS LEGEND
 EGL-1--8mmHS+12mm AIR GAP+10mmTP THK. I.G.U.
 EGL-2--10mm THK. CLEAR TEMPERED GLASS
 EGL-4--10mm THK. TEMPERED ACID ETCHED GLASS
 EGL-1A--8mmHS+12mm AIR GAP+8mmTP THK. I.G.U.

NO.	DATE	REVISED	BY
E	18/05/2022	REVISION SUBJECT TO ARCH.COMMENT	Ivan
D	08/04/2022	REVISION SUBJECT TO ARCH.COMMENT	Ivan
C	17/12/2021	REVISION SUBJECT TO ARCH.COMMENT	Ivan
B	29/11/2021	REVISION SUBJECT TO ARCH.COMMENT	Ivan
A	03/11/2021	REVISION SUBJECT TO ARCH.COMMENT	Ivan

JOB NO. : J-856
 PROJECT :
 PROPOSED DEVELOPMENT ABOVE
 LIGHT RAIL TIN WING STOP,TSWTL
 NO.23,AREA 33,TIN SHUI WAI, N.T.

TITLE :
 WINDOW SCHEDULE FOR
 TOWER 2 ALUM. WINDOW

DATE : 02-Aug-21 SCALE : 1:40
 DRAWN BY : Ivan CHECKED BY :

美特鋁質有限公司
MIDI ALUMINIUM FABRICATOR LTD.
 Units 6-8, Sunray Industrial Centre, 1/F
 610 Che Kwo Ling Road, Kowloon
 Tel:23489211-4 Fax:(852)2727666
 DWG NO. : J856-SD-PW-5202 REV. : E

ELEVATION

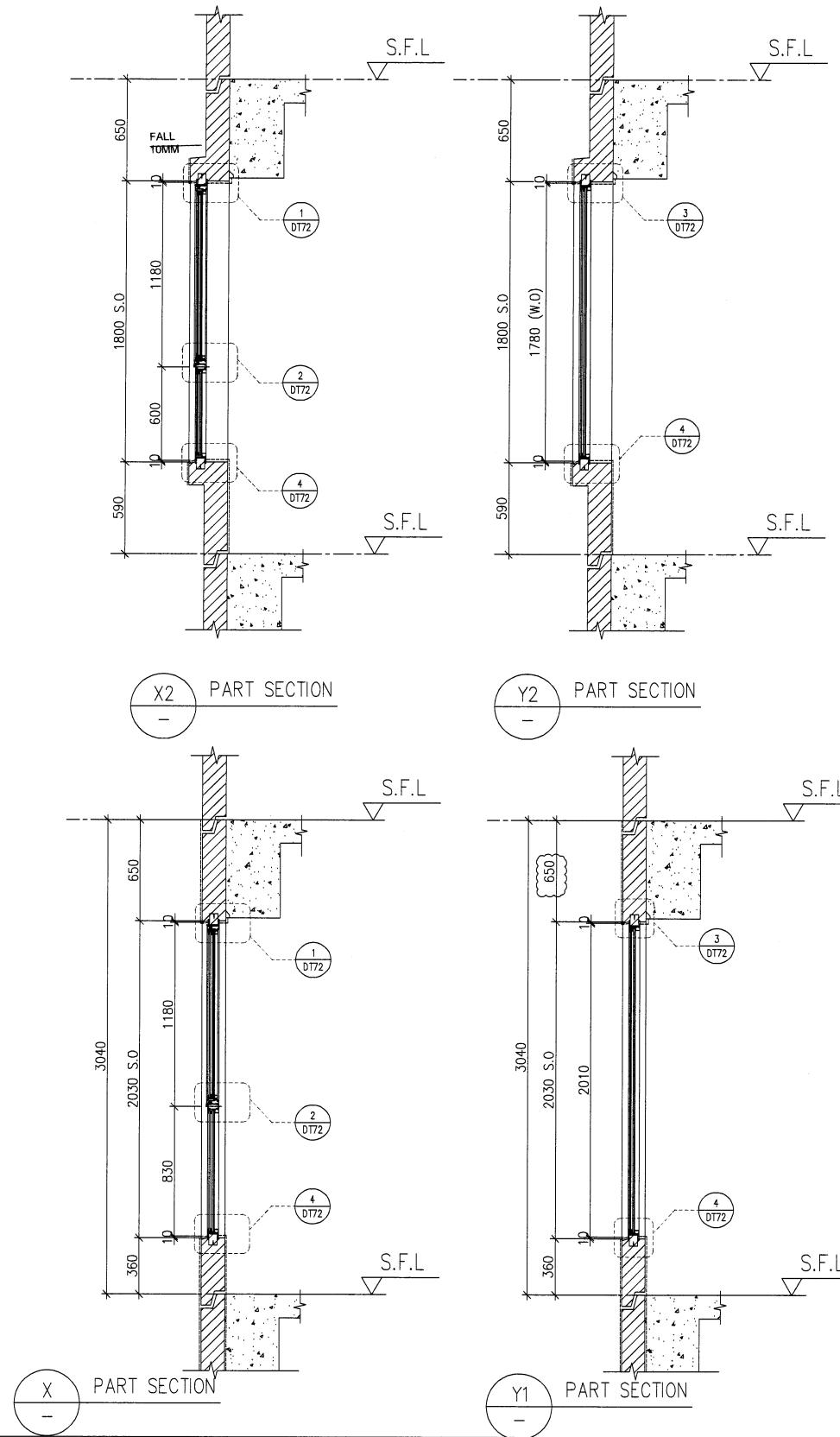
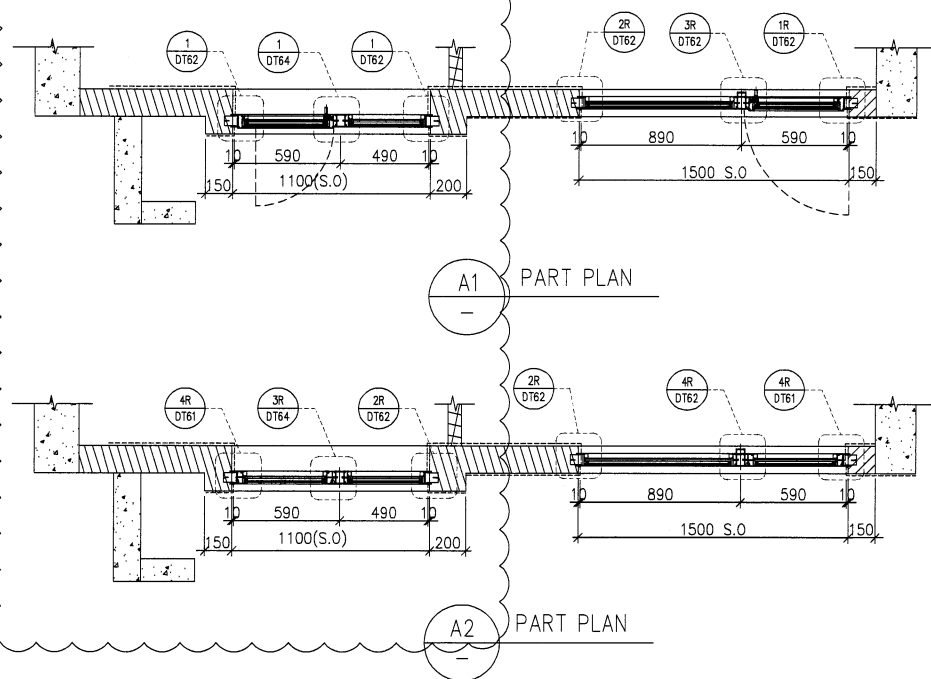
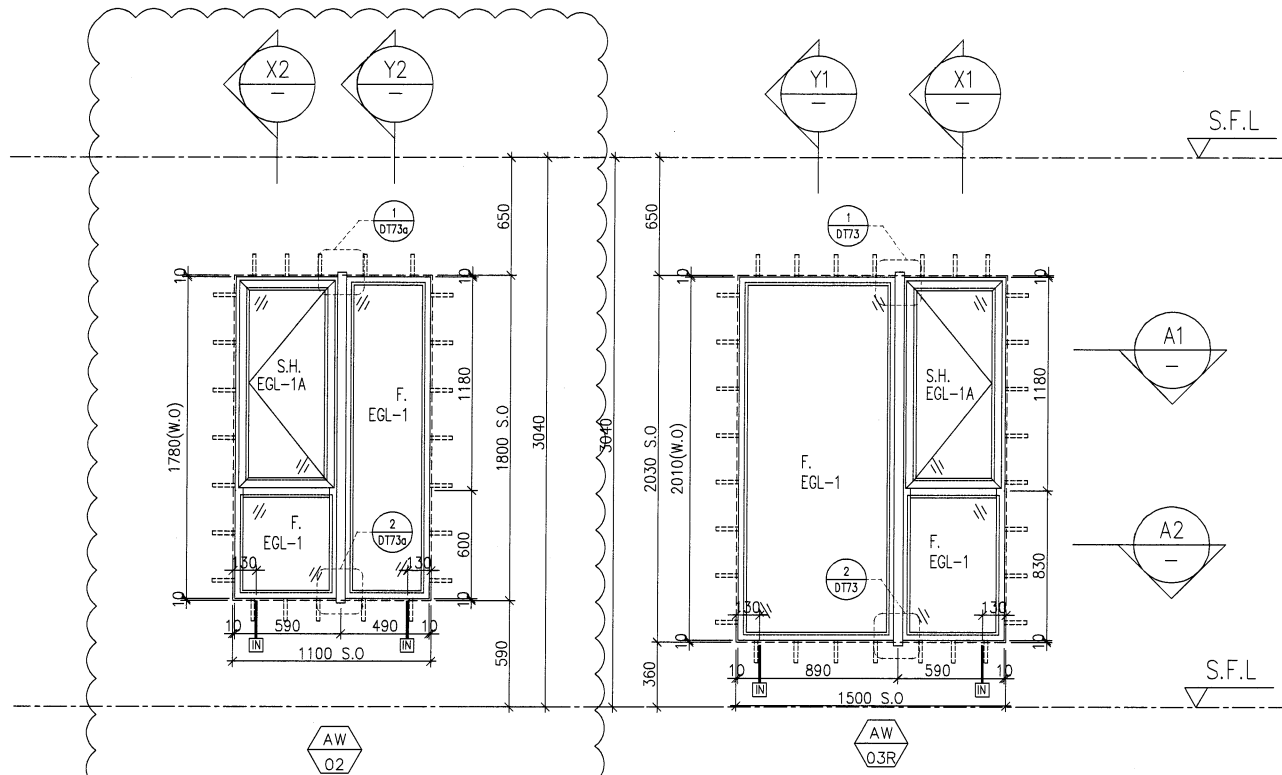

FACADE CODE		
LWK	鴻輝	UNIT
PF-03R	T2PF-08	A2

WINDOW MARK	AW 02	AW 03R
LOCATION	3/F-42/F(4/F,13/F,14/F,24/F,34/F OMITTED) UNIT A2	
SECTION	70mm ALUM. SECTION	
GLAZING	EGL-1,EGL-1A	
QUANTITY	35 Nos.	
REMARKS	FACADE(TYPE T2PF03R FOR 3/F~42/F)	

B.D. REF :

CLIENT :

SUN HUNG KAI
REAL ESTATE AGENCY LTD.
42/F SUN HUNG KAI CENTRE, WANCHAI, HONGKONG

ARCHITECT :

lwk&partners
architects

MAIN CONTRACTOR :

Yee Fai Building Contractors Ltd.

STRUCTURAL ENGINEER :

ARUP

FACADE CONSULTANT:

ALPHA CONSULTING LIMITED
Steel Structure & Facade Specialist

NOTE :

1. ALL DIMENSIONS ARE IN mm.
2. ALL ELEVATIONS ARE VIEWED FROM OUTSIDE.
3. ALL DIMENSIONS TO BE VERIFIED ON SITE BEFORE FABRICATION.

LEGEND :

- (X1) --- DETAIL MARK NO.
- (X001) --- REFER SHEET NO.

1. F.F.L. --- FINISHED FLOOR LEVEL
2. S.F.L. --- STRUCTURAL FLOOR LEVEL
3. (R) --- REVERSED DETAIL
4. GLASS LEGEND
EGL-1--8mmHS+12mm AIR GAP+10mmTP THK. I.G.U.
EGL-2--10mm THK. CLEAR TEMPERED GLASS
EGL-4--10mm THK. TEMPERED ACID ETCHED GLASS
EGL-1A-8mmHS+12mm AIR GAP+8mmTP THK. I.G.U.

NO.	DATE	REVISED	BY
E	17/05/2022	REVISION SUBJECT TO ARCH.COMMENT	ivan
D	08/04/2022	REVISION SUBJECT TO ARCH.COMMENT	ivan
C	17/12/2021	REVISION SUBJECT TO ARCH.COMMENT	ivan
B	29/11/2021	REVISION SUBJECT TO ARCH.COMMENT	ivan
A	03/11/2021	REVISION SUBJECT TO ARCH.COMMENT	ivan

JOB NO. : J-856

PROJECT :
PROPOSED DEVELOPMENT ABOVE
LIGHT RAIL TIN WING STOP,TSWTL
NO.23,AREA 33,TIN SHUI WAI, N.T.

TITLE :
WINDOW SCHEDULE FOR
TOWER 2 ALUM. WINDOW

DATE : 02-Aug-21

SCALE : 1:40

DRAWN BY : Ivan

CHECKED BY :

英特鋁質有限公司
MIDI ALUMINIUM FABRICATOR LTD.
Units 6-8, Sunray Industrial Centre, 1/F
610 Cha Kwo Ling Road, Kowloon
Tel:23489211-4 Fax:(852)2727666

DWG NO. : J856-SD-PW-5203

REV. : E

ELEVATION

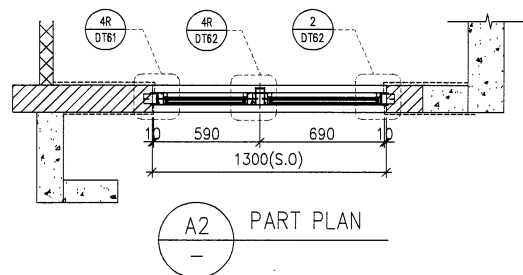
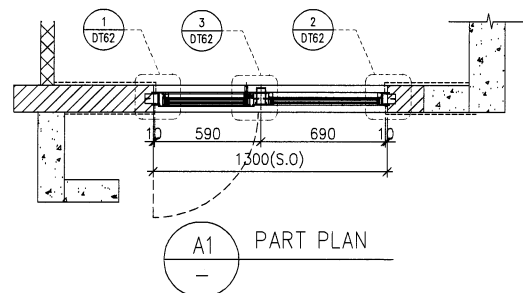
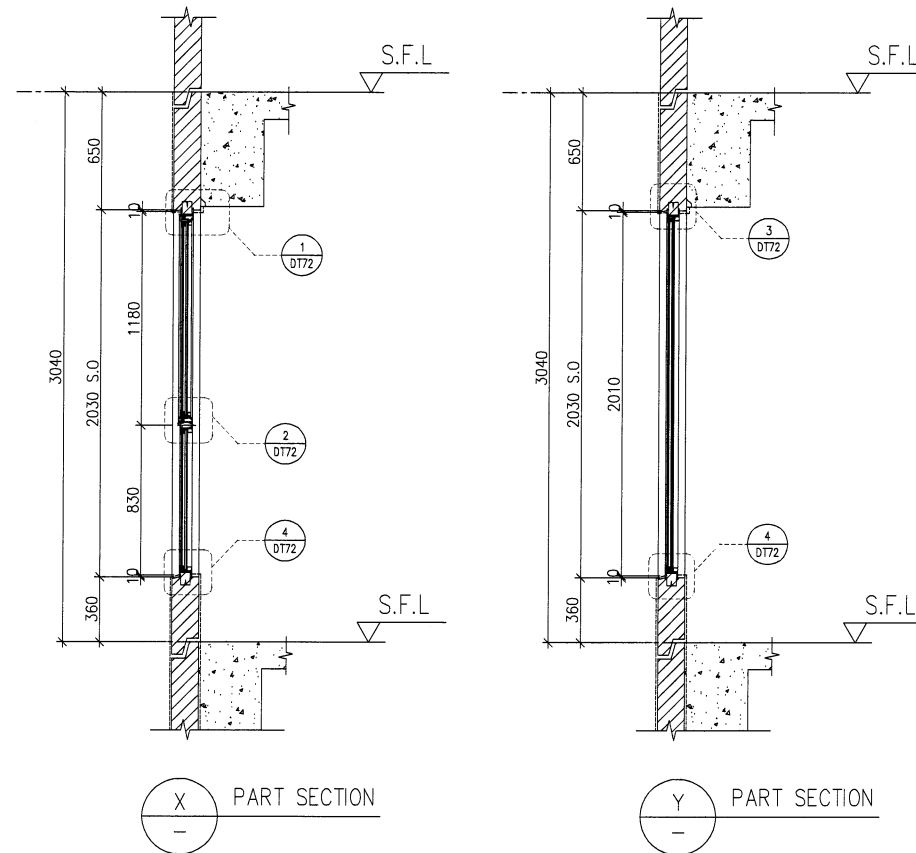
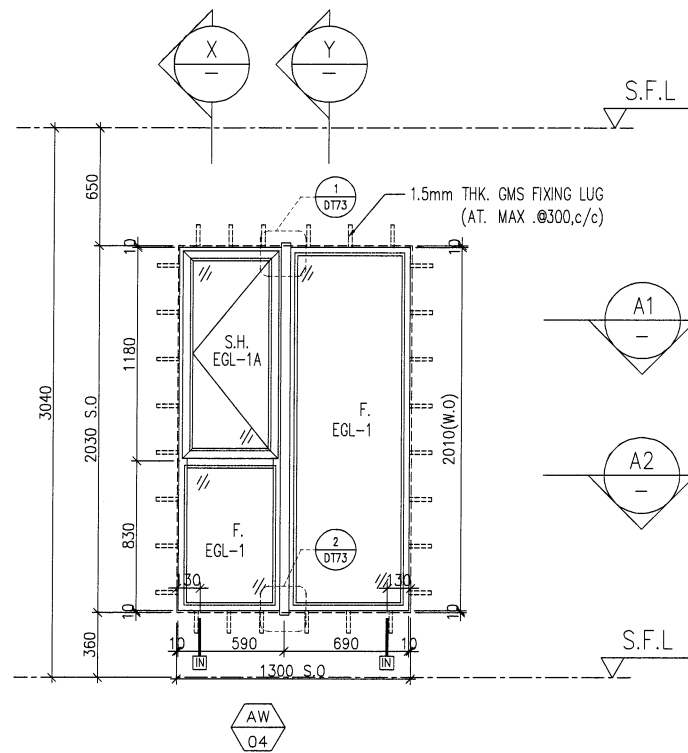

FACADE CODE		
LWK	鴻輝	UNIT
PF-04	T2PF-24	B7
PF-04R	T2PF-07	A3
PF-04R	T2PF-15	A7

WINDOW MARK	AW 04
LOCATION	3/F-42/F(4/F,13/F,14/F,24/F,34/F OMITTED) UNIT (A3, A7, B7)
SECTION	70mm ALUM. SECTION
GLAZING	EGL-1,EGL-1A
QUANTITY	35 Nos / 35 Nos / 35 Nos
REMARKS	FACADE(TYPE T2PF04/04R) FOR 3/F~42/F)

B.D. REF :

CLIENT :
SUN HUNG KAI
 REAL ESTATE AGENCY LTD.
 42/F SUN HUNG KAI CENTRE, WANCHAI, HONGKONG

ARCHITECT :
lwk&partners
 architects

MAIN CONTRACTOR :
Yee Fai Building Contractors Ltd.

STRUCTURAL ENGINEER :
ARUP

FACADE CONSULTANT:
ALPHA CONSULTING LIMITED
 Steel Structure & Facade Specialist

NOTE :
 1. ALL DIMENSIONS ARE IN mm.
 2. ALL ELEVATIONS ARE VIEWED FROM OUTSIDE.
 3. ALL DIMENSIONS TO BE VERIFIED ON SITE BEFORE FABRICATION.

LEGEND :
 X1 --- DETAIL MARK NO.
 X001 --- REFER SHEET NO.

1. F.F.L. --- FINISHED FLOOR LEVEL
 2. S.F.L. --- STRUCTURAL FLOOR LEVEL
 3. (R) --- REVERSED DETAIL
 4. GLASS LEGEND
 EGL-1--8mmHS+12mm AIR GAP+10mmTP THK. I.G.U.
 EGL-2--10mm THK. CLEAR TEMPERED GLASS
 EGL-4--10mm THK. TEMPERED ACID ETCHED GLASS
 EGL-1A--8mmHS+12mm AIR GAP+8mmTP THK. I.G.U.

NO.	DATE	REVISED	BY
F	17/05/2022	REVISION SUBJECT TO ARCH.COMMENT	Ivan
E	08/04/2022	REVISION SUBJECT TO ARCH.COMMENT	Ivan
D	17/12/2021	REVISION SUBJECT TO ARCH.COMMENT	Ivan
C	29/11/2021	REVISION SUBJECT TO ARCH.COMMENT	Ivan
B	03/11/2021	REVISION SUBJECT TO ARCH.COMMENT	Ivan
A	12/10/2021	REVISION SUBJECT TO ARCH.COMMENT	Ivan

JOB NO. : J-856
 PROJECT : PROPOSED DEVELOPMENT ABOVE LIGHT RAIL TIN WING STOP, TSWTL NO.23, AREA 33, TIN SHUI WAI, N.T.

TITLE : WINDOW SCHEDULE FOR TOWER 2 ALUM. WINDOW

DATE : 02-Aug-21 SCALE : 1:40
 DRAWN BY : Ivan CHECKED BY :

英特鋁質有限公司
MIDI ALUMINIUM FABRICATOR LTD.
 Units 6-8, Sunray Industrial Centre, 1/F
 610 Cha Kwo Ling Road, Kowloon
 Tel:23489211-4 Fax:(852)2727666
 DWG NO. : J856-SD-PW-5204 REV. : F

ELEVATION

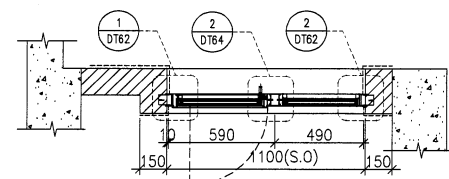
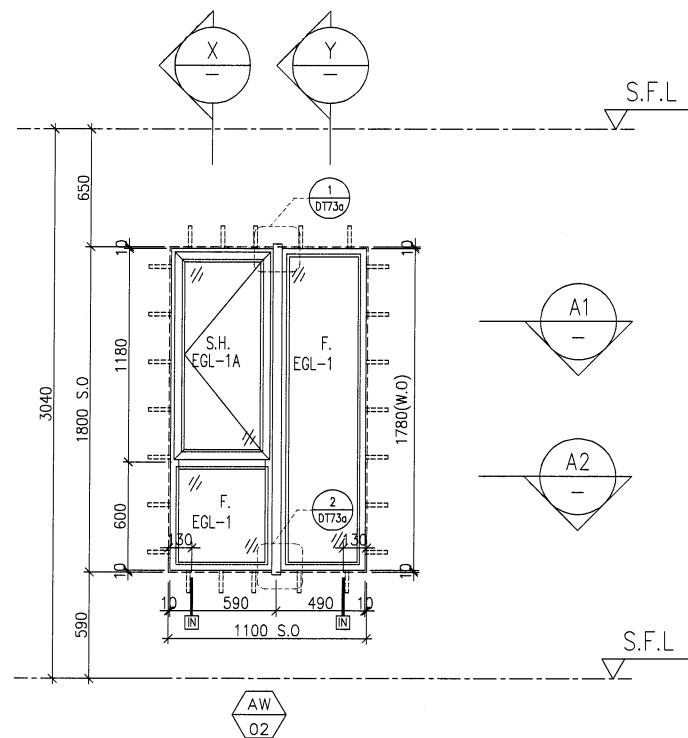

A1 PART PLAN

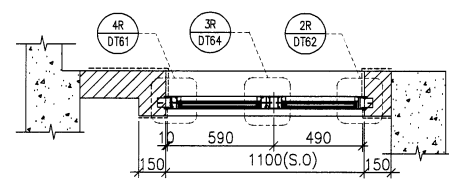

A2 PART PLAN

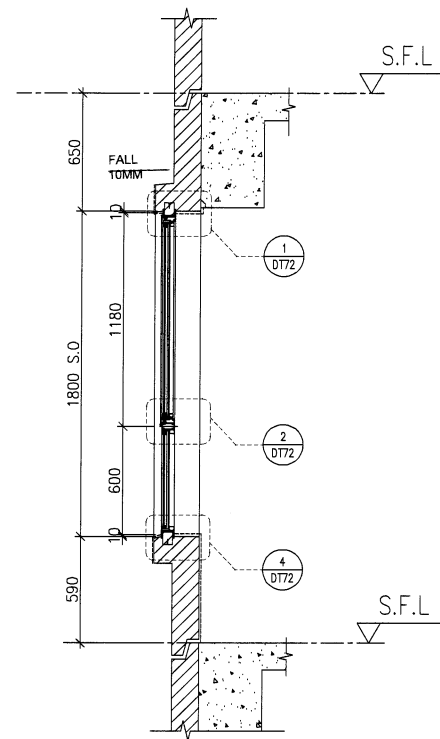

X PART SECTION

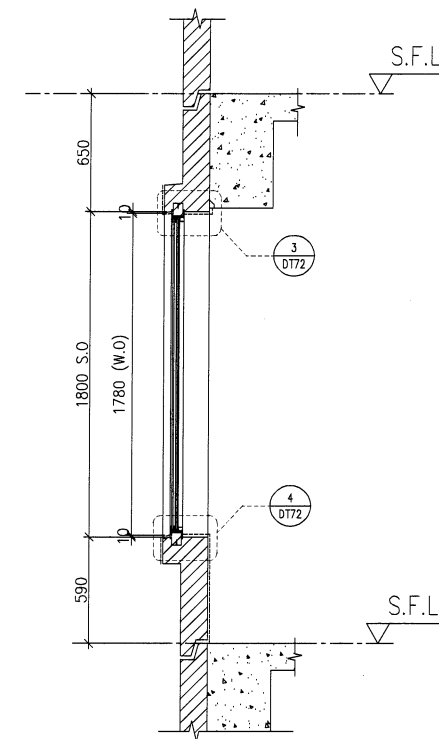

Y PART SECTION

FACADE CODE		
LWK	鴻輝	UNIT
PF-05	T2PF-06	A3
PF-05	T2PF-14	A7
PF-05	T2PF-22	B6
PF-05	T2PF-25	B7

FACADE CODE		
LWK	鴻輝	UNIT
PF-05R	T2PF-02	B2

WINDOW MARK	AW 02
LOCATION	3/F-42/F(4/F,13/F,14/F,24/F,34/F OMITTED) UNIT(A3, A7(5-42/F), B6(5-42/F), B7(5-42/F))
SECTION	70mm ALUM. SECTION
GLAZING	EGL-1,EGL-1A
QUANTITY	35 Nos / 34 Nos / 34 Nos / 34 Nos
REMARKS	FACADE(TYPE T2PF05 FOR 3/F~42/F)

WINDOW MARK	AW 02R
LOCATION	3/F-42/F(4/F,13/F,14/F,24/F,34/F OMITTED) UNIT(B2, A7(3/F), B6(3/F), B7(3/F))
SECTION	70mm ALUM. SECTION
GLAZING	EGL-1,EGL-1A
QUANTITY	35 Nos / 1 No / 1 No / 1 No
REMARKS	FACADE(TYPE T2PF05 FOR 3/F~42/F)

B.D. REF :

CLIENT :
SUN HUNG KAI
 REAL ESTATE AGENCY LTD.
 42/F SUN HUNG KAI CENTRE, WANCHAI, HONGKONG

ARCHITECT :
lwk&partners
 architects

MAIN CONTRACTOR :
怡輝建築有限公司
Yee Fai Building Contractors Ltd.

STRUCTURAL ENGINEER :
ARUP

FACADE CONSULTANT:
ALPHA CONSULTING LIMITED
 Steel Structure & Facade Specialist

NOTE:
 1. ALL DIMENSIONS ARE IN mm.
 2. ALL ELEVATIONS ARE VIEWED FROM OUTSIDE.
 3. ALL DIMENSIONS TO BE VERIFIED ON SITE BEFORE FABRICATION.

LEGEND:
 (X1) — DETAIL MARK NO.
 (X001) — REFER SHEET NO.
 1. F.F.L. — FINISHED FLOOR LEVEL
 2. S.F.L. — STRUCTURAL FLOOR LEVEL
 3. (R) — REVERSED DETAIL
 4. GLASS LEGEND
 EGL-1 — 8mmHS+12mm AIR GAP+10mmTP THK. I.G.U.
 EGL-2 — 10mm THK. CLEAR TEMPERED GLASS
 EGL-4 — 10mm THK. TEMPERED ACID ETCHED GLASS
 EGL-1A — 8mmHS+12mm AIR GAP+8mmTP THK. I.G.U.

E	17/05/2022	REVISION SUBJECT TO ARCH.COMMENT	ivan
D	08/04/2022	REVISION SUBJECT TO ARCH.COMMENT	ivan
C	17/12/2021	REVISION SUBJECT TO ARCH.COMMENT	ivan
B	29/11/2021	REVISION SUBJECT TO ARCH.COMMENT	ivan
A	03/11/2021	REVISION SUBJECT TO ARCH.COMMENT	ivan
NO.	DATE	REVISED	BY

JOB NO. : J-856
 PROJECT : PROPOSED DEVELOPMENT ABOVE LIGHT RAIL TIN WING STOP,TSWTL NO.23,AREA 33,TIN SHUI WAI, N.T.

TITLE : WINDOW SCHEDULE FOR TOWER 2 ALUM. WINDOW

DATE : 02-Aug-21 SCALE : 1:40
 DRAWN BY : Ivan CHECKED BY :
美特鋁質有限公司
MIDI ALUMINIUM FABRICATOR LTD.
 Units 6-8, Sunray Industrial Centre, 1/F
 610 Cha Kwo Ling Road, Kowloon
 Tel:23489211-4 Fax:(852)2727666
 DWG NO. : J856-SD-PW-5205 REV. : E

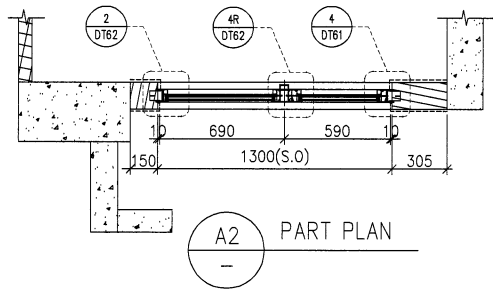
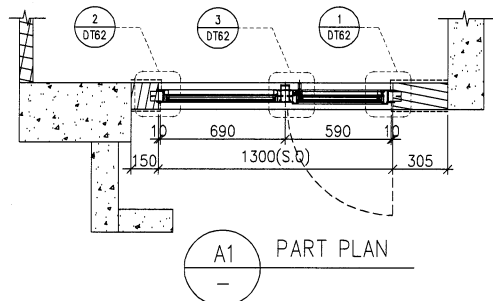
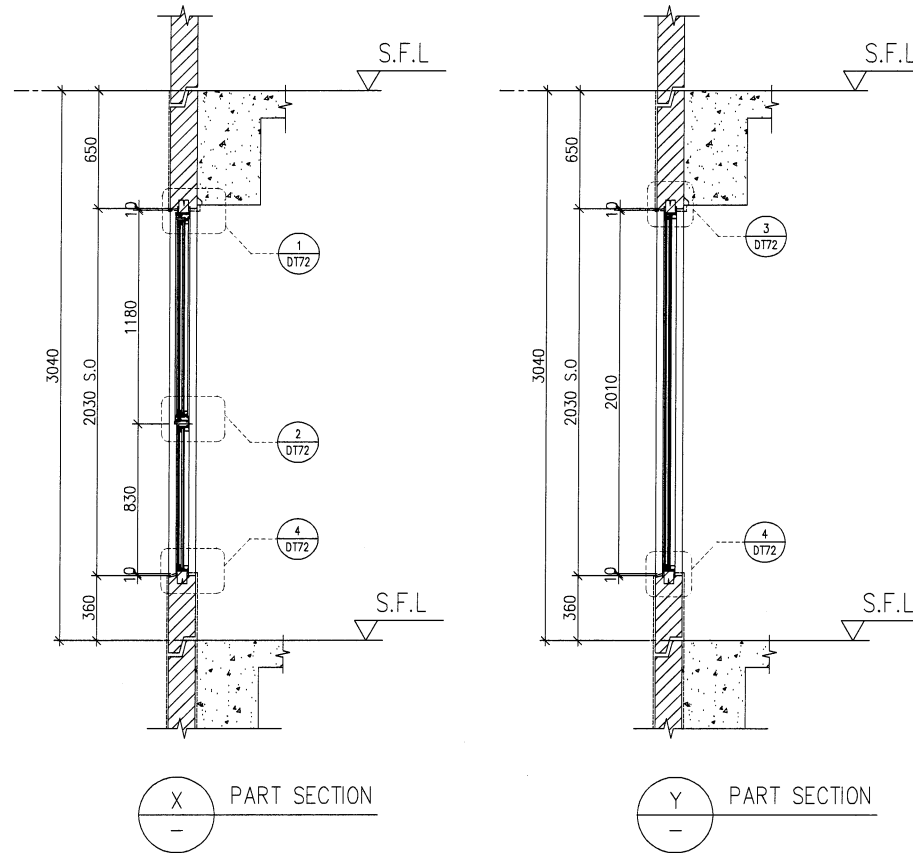
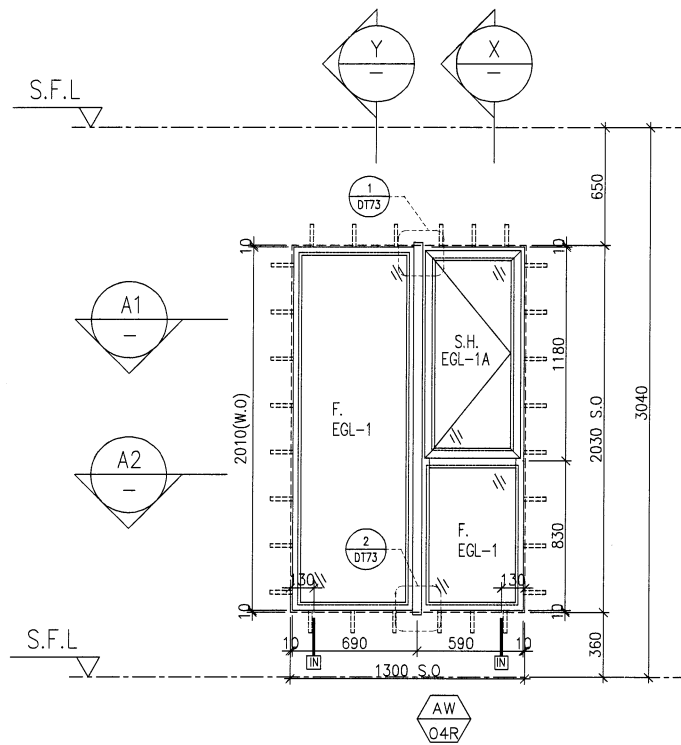

FACADE CODE		
LWK	鴻輝	UNIT
PF-06	T2PF-15A	A6
PF-06R	T2PF-17	A5

WINDOW MARK	AW 04R	AW 04
LOCATION	3/F-42/F(4/F,13/F,14/F,24/F,34/F OMITTED) UNIT A5	3/F-42/F(4/F,13/F,14/F,24/F,34/F OMITTED) UNIT A6
SECTION	70mm ALUM. SECTION	70mm ALUM. SECTION
GLAZING	EGL-1,EGL-1A	EGL-1,EGL-1A
QUANTITY	35 Nos	35 Nos
REMARKS	FACADE(TYPE T2PF06R FOR 3/F~42/F)	FACADE(TYPE T2PF06 FOR 3/F~42/F)

B.D. REF :

CLIENT :
SUN HUNG KAI
 REAL ESTATE AGENCY LTD.
 42/F SUN HUNG KAI CENTRE, WANCHAI, HONGKONG

ARCHITECT :
lwk&partners
 architects

MAIN CONTRACTOR :
Yee Fal Building Contractors Ltd.

STRUCTURAL ENGINEER :
ARUP

FACADE CONSULTANT:
ALPHA CONSULTING LIMITED
 Steel Structure & Facade Specialist

NOTE :
 1. ALL DIMENSIONS ARE IN mm.
 2. ALL ELEVATIONS ARE VIEWED FROM OUTSIDE.
 3. ALL DIMENSIONS TO BE VERIFIED ON SITE BEFORE FABRICATION.

LEGEND :
 X1 - DETAIL MARK NO.
 X001 - REFER SHEET NO.

1. F.F.L. -- FINISHED FLOOR LEVEL
 2. S.F.L. -- STRUCTURAL FLOOR LEVEL
 3. (B) -- REVERSED DETAIL
 4. GLASS LEGEND
 EGL-1--8mmHS+12mm AIR GAP+10mmTP THK. I.G.U.
 EGL-2--10mm THK. CLEAR TEMPERED GLASS
 EGL-4--10mm THK. TEMPERED ACID ETCHED GLASS
 EGL-1A-8mmHS+12mm AIR GAP+8mmTP THK. I.G.U.

NO.	DATE	REVISED	BY
F	17/05/2022	REVISION SUBJECT TO ARCH.COMMENT	ivan
E	08/04/2022	REVISION SUBJECT TO ARCH.COMMENT	ivan
D	17/12/2021	REVISION SUBJECT TO ARCH.COMMENT	ivan
C	29/11/2021	REVISION SUBJECT TO ARCH.COMMENT	ivan
B	03/11/2021	REVISION SUBJECT TO ARCH.COMMENT	ivan
A	12/10/2021	REVISION SUBJECT TO ARCH.COMMENT	ivan

JOB NO. : J-856
 PROJECT : PROPOSED DEVELOPMENT ABOVE LIGHT RAIL TIN WING STOP, TSWTL NO.23, AREA 33, TIN SHUI WAI, N.T.

TITLE : WINDOW SCHEDULE FOR TOWER 2 ALUM. WINDOW

DATE : 02-Aug-21 SCALE : 1:40
 DRAWN BY : ivan CHECKED BY :

英特鋁質有限公司
 MIDI ALUMINIUM FABRICATOR LTD.
 Units 6-8, Sunray Industrial Centre, 1/F
 610 Cha Kwo Ling Road, Kowloon
 Tel:23489211-4 Fax:(852)2727666
 DWG NO. : J856-SD-PW-5206 REV. : F

ELEVATION

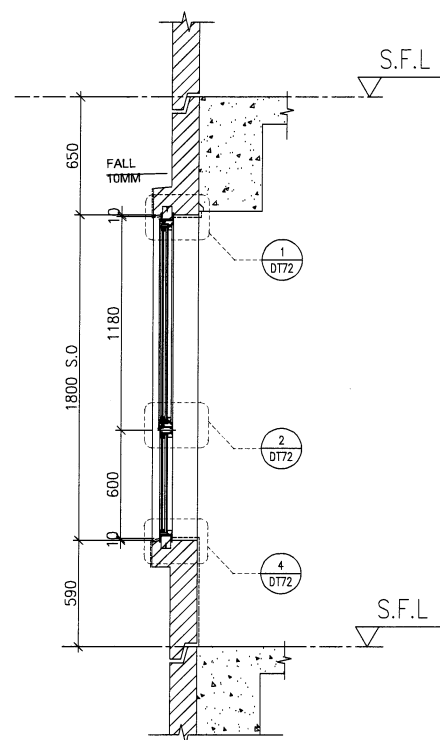
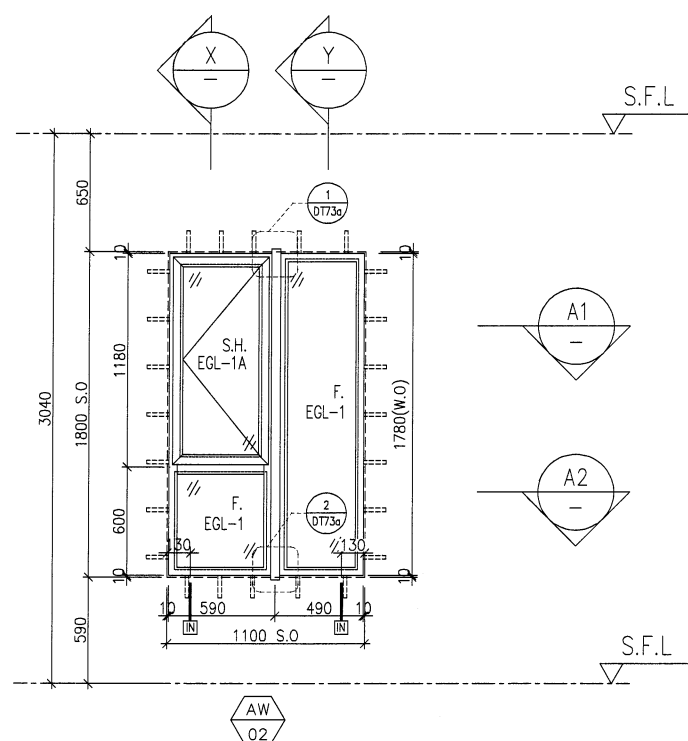

X PART SECTION

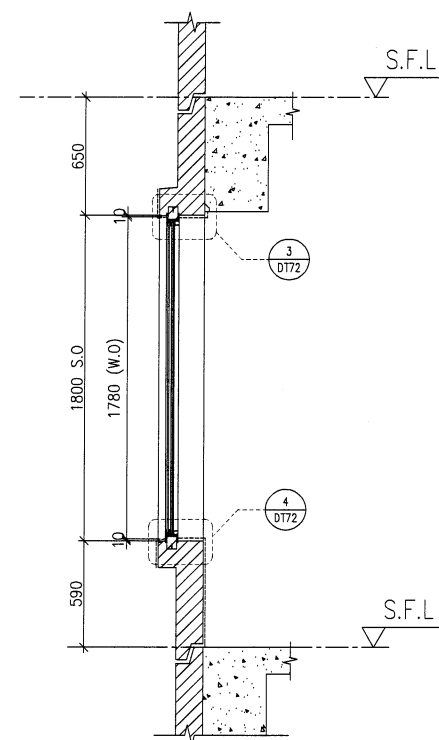

Y PART SECTION

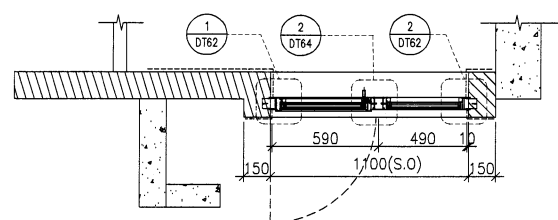

A1 PART PLAN

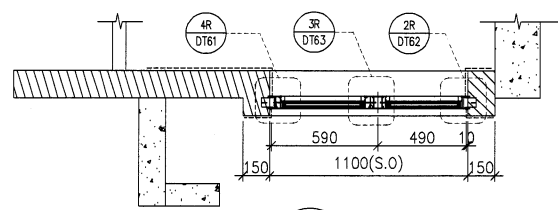

A2 PART PLAN

FACADE CODE		
LWK	鴻輝	UNIT
PF-08	T2PF-01	B1
PF-08	T2PF-13	A8
PF-08R	T2PF-26	B8

WINDOW MARK	AW 02
LOCATION	3/F-42/F(4/F,13/F,14/F,24/F,34/F OMITTED) UNIT B1 , A8
SECTION	70mm ALUM. SECTION
GLAZING	EGL-1,EGL-1A
QUANTITY	35 Nos/35 Nos
REMARKS	FACADE(TYPE T2PF08) FOR 3/F~42/F)

WINDOW MARK	AW 02R
LOCATION	3/F-42/F(4/F,13/F,14/F,24/F,34/F OMITTED) UNIT B8
SECTION	70mm ALUM. SECTION
GLAZING	EGL-1,EGL-1A
QUANTITY	35 Nos
REMARKS	FACADE(TYPE T2PF08R) FOR 3/F~42/F)

B.D. REF :

CLIENT :

SUN HUNG KAI
REAL ESTATE AGENCY LTD.
42/F SUN HUNG KAI CENTRE, WANCHAI, HONGKONG

ARCHITECT :

lwk&partners
architects

MAIN CONTRACTOR :

Yee Fai Building Contractors Ltd.

STRUCTURAL ENGINEER :

ARUP

FACADE CONSULTANT:

ALPHA CONSULTING LIMITED
Steel Structure & Facade Specialist

NOTE :

1. ALL DIMENSIONS ARE IN mm.
2. ALL ELEVATIONS ARE VIEWED FROM OUTSIDE.
3. ALL DIMENSIONS TO BE VERIFIED ON SITE BEFORE FABRICATION.

LEGEND :

- X1 — DETAIL MARK NO.
- X001 — REFER SHEET NO.

1. F.F.L. -- FINISHED FLOOR LEVEL
2. S.F.L. -- STRUCTURAL FLOOR LEVEL
3. (R) -- REVERSED DETAIL

4. GLASS LEGEND

- EGL-1--8mmHS+12mm AIR GAP+10mmTP THK. I.G.U.
- EGL-2--10mm THK. CLEAR TEMPERED GLASS
- EGL-4--10mm THK. TEMPERED ACID ETCHED GLASS
- EGL-1A--8mmHS+12mm AIR GAP+8mmTP THK. I.G.U.

NO.	DATE	REVISED	BY
E	18/05/2022	REVISION SUBJECT TO ARCH.COMMENT	Ivan
D	08/04/2022	REVISION SUBJECT TO ARCH.COMMENT	Ivan
C	17/12/2021	REVISION SUBJECT TO ARCH.COMMENT	Ivan
B	29/11/2021	REVISION SUBJECT TO ARCH.COMMENT	Ivan
A	03/11/2021	REVISION SUBJECT TO ARCH.COMMENT	Ivan

JOB NO. : J-856

PROJECT :
PROPOSED DEVELOPMENT ABOVE
LIGHT RAIL TIN WING STOP, TSWTL
NO.23, AREA 33, TIN SHUI WAI, N.T.

TITLE :
WINDOW SCHEDULE FOR
TOWER 2 ALUM. WINDOW

DATE : 02-Aug-21 SCALE : 1:40

DRAWN BY : Ivan CHECKED BY :

美特鋁質有限公司
MIDI ALUMINIUM FABRICATOR LTD.
Units 6-8, Sunray Industrial Centre, 1/F
610 Cha Kwo Ling Road, Kowloon
Tel:23489211-4 Fax:(852)2727666

DWG NO. : J856-SD-PW-5207 REV. : E

ELEVATION

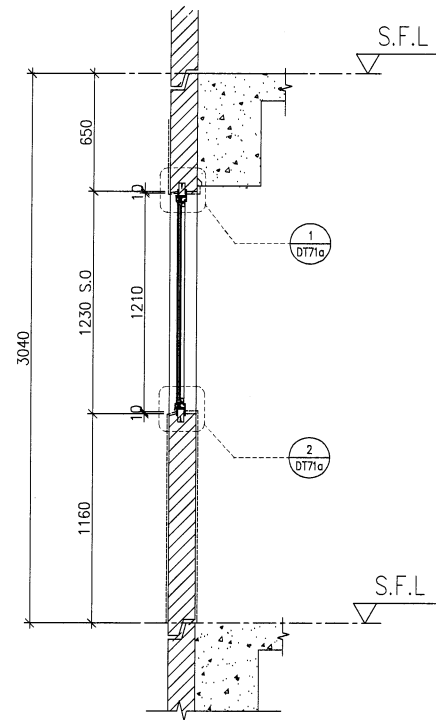
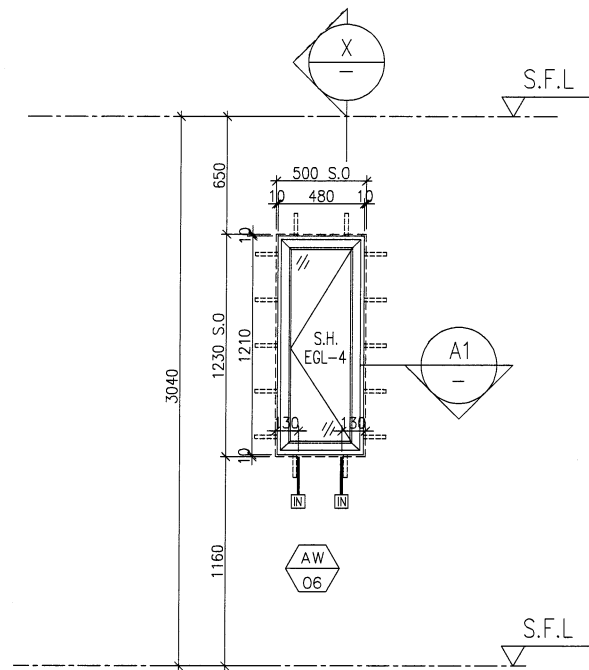

X
—
PART SECTION

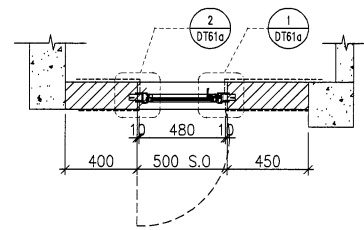

A1
—
PART PLAN

FACADE CODE		
LWK	鴻輝	UNIT
PF-09	T2PF-05	B3

WINDOW MARK	AW 06
LOCATION	3/F-42/F(4/F,13/F,14/F,24/F,34/F OMITTED) UNIT B3
SECTION	50mm ALUM. SECTION
GLAZING	EGL-4
QUANTITY	35 Nos
REMARKS	FACADE(TYPE T2PF09 FOR 3/F~42/F)

B.D. REF :

CLIENT :

SUN HUNG KAI
REAL ESTATE AGENCY LTD.
42/F SUN HUNG KAI CENTRE, WANCHAI, HONGKONG

ARCHITECT :

lwk&partners
architects

MAIN CONTRACTOR :

Yee Fai Building Contractors Ltd.

STRUCTURAL ENGINEER :

ARUP

FACADE CONSULTANT:

ALPHA CONSULTING LIMITED
Steel Structure & Facade Specialist

NOTE :

1. ALL DIMENSIONS ARE IN mm.
2. ALL ELEVATIONS ARE VIEWED FROM OUTSIDE.
3. ALL DIMENSIONS TO BE VERIFIED ON SITE BEFORE FABRICATION.

LEGEND :

- X1 — DETAIL MARK NO.
- X001 — REFER SHEET NO.

1. F.F.L. — FINISHED FLOOR LEVEL
2. S.F.L. — STRUCTURAL FLOOR LEVEL
3. (R) — REVERSED DETAIL

4. GLASS LEGEND :

- EGL-1 — 8mmHS+12mm AIR GAP+10mmTP THK. I.G.U.
- EGL-2 — 10mm THK. CLEAR TEMPERED GLASS
- EGL-4 — 10mm THK. TEMPERED ACID ETCHED GLASS
- EGL-1A — 8mmHS+12mm AIR GAP+8mmTP THK. I.G.U.

NO.	DATE	REVISED	BY
E	18/05/2022	REVISION SUBJECT TO ARCH.COMMENT	Ivan
D	08/04/2022	REVISION SUBJECT TO ARCH.COMMENT	Ivan
C	17/12/2021	REVISION SUBJECT TO ARCH.COMMENT	Ivan
B	29/11/2021	REVISION SUBJECT TO ARCH.COMMENT	Ivan
A	03/11/2021	REVISION SUBJECT TO ARCH.COMMENT	Ivan

JOB NO. : J-856

PROJECT :
PROPOSED DEVELOPMENT ABOVE
LIGHT RAIL TIN WING STOP, TSWTL
NO.23, AREA 33, TIN SHUI WAI, N.T.

TITLE :
WINDOW SCHEDULE FOR
TOWER 2 ALUM. WINDOW

DATE : 02-Aug-21 SCALE : 1:40

DRAWN BY : Ivan CHECKED BY :

英特鋁質有限公司
MIDI ALUMINIUM FABRICATOR LTD.
Units 6-8, Sunray Industrial Centre, 1/F
610 Cha Kwo Ling Road, Kowloon
Tel:23489211-4 Fax:(852)2727666

DWG NO. : J856-SD-PW-5208 REV. : E

ELEVATION

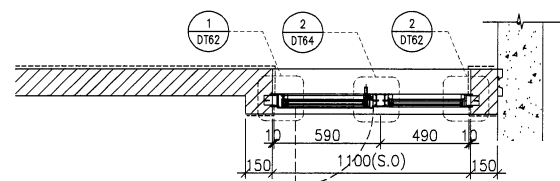
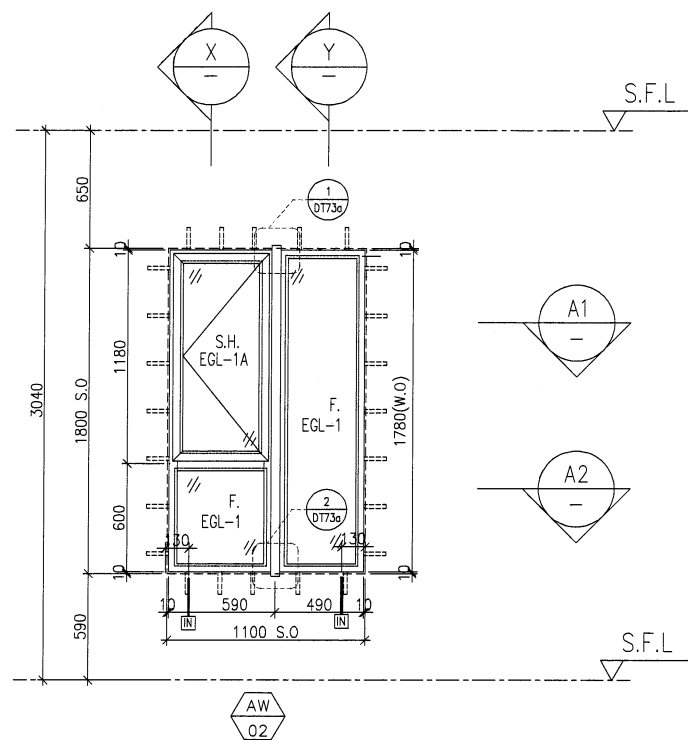

A1 PART PLAN

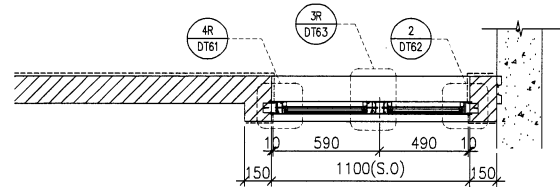

A2 PART PLAN

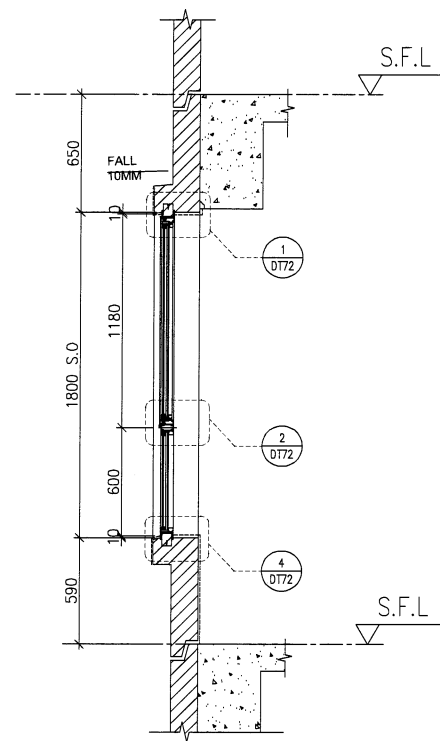

X PART SECTION

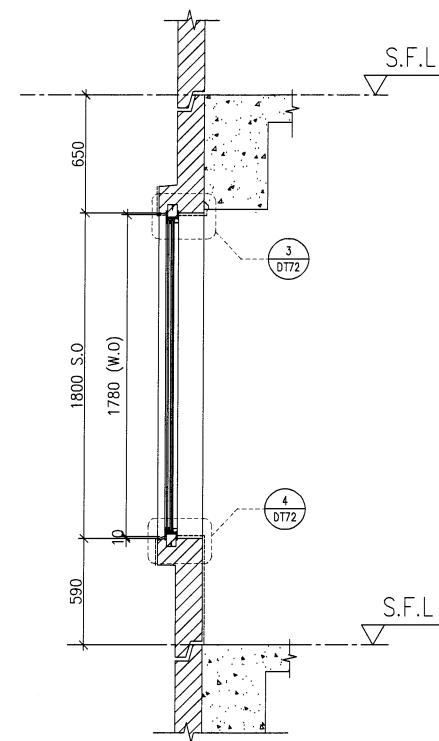

Y PART SECTION

FACADE CODE		
LWK	鴻輝	UNIT
PF-19	T2PF-04	B3

WINDOW MARK	AW 02
LOCATION	3/F-42/F(4/F,13/F,14/F,24/F,34/F OMITTED) UNIT B3
SECTION	70mm ALUM. SECTION
GLAZING	EGL-1,EGL-1A
QUANTITY	35 Nos
REMARKS	FACADE(TYPE T1PF19 FOR 3/F~42/F)

B.D. REF :

CLIENT :

SUN HUNG KAI
REAL ESTATE AGENCY LTD.
42/F SUN HUNG KAI CENTRE, WANCHAI, HONGKONG

ARCHITECT :

IWK&partners
architects

MAIN CONTRACTOR :

Yee Fai 怡輝建築有限公司
Building Contractors Ltd.

STRUCTURAL ENGINEER :

ARUP

FACADE CONSULTANT:

ALPHA CONSULTING LIMITED
Steel Structure & Facade Specialist

NOTE :

1. ALL DIMENSIONS ARE IN mm.
2. ALL ELEVATIONS ARE VIEWED FROM OUTSIDE.
3. ALL DIMENSIONS TO BE VERIFIED ON SITE BEFORE FABRICATION.

LEGEND :

- X1 — DETAIL MARK NO.
- X001 — REFER SHEET NO.

1. F.F.L. — FINISHED FLOOR LEVEL
2. S.F.L. — STRUCTURAL FLOOR LEVEL
3. (R) — REVERSED DETAIL
4. GLASS LEGEND

EGL-1—8mmHS+12mm AIR GAP+10mmTP THK. I.G.U.
EGL-2—10mm THK. CLEAR TEMPERED GLASS
EGL-4—10mm THK. TEMPERED ACID ETCHED GLASS
EGL-1A—8mmHS+12mm AIR GAP+8mmTP THK. I.G.U.

NO.	DATE	REVISION	BY
F	18/05/2022	REVISION SUBJECT TO ARCH.COMMENT	Ivan
E	08/04/2022	REVISION SUBJECT TO ARCH.COMMENT	Ivan
D	17/12/2021	REVISION SUBJECT TO ARCH.COMMENT	Ivan
C	29/11/2021	REVISION SUBJECT TO ARCH.COMMENT	Ivan
B	03/11/2021	REVISION SUBJECT TO ARCH.COMMENT	Ivan
A	12/10/2021	REVISION SUBJECT TO ARCH.COMMENT	Ivan

JOB NO. : J-856

PROJECT :
PROPOSED DEVELOPMENT ABOVE
LIGHT RAIL TIN WING STOP, TSWTL
NO.23, AREA 33, TIN SHUI WAI, N.T.

TITLE :
WINDOW SCHEDULE FOR
TOWER 2 ALUM. WINDOW

DATE : 02-Aug-21 SCALE : 1:40

DRAWN BY : Ivan CHECKED BY :

美特鋁質有限公司
MIDI ALUMINIUM FABRICATOR LTD.
Units 6-8, Sunray Industrial Centre, 1/F
610 Cha Kwo Ling Road, Kowloon
Tel:23489211-4 Fax:(852)27727666

DWG NO. : J856-SD-PW-5209 REV. : F

ELEVATION

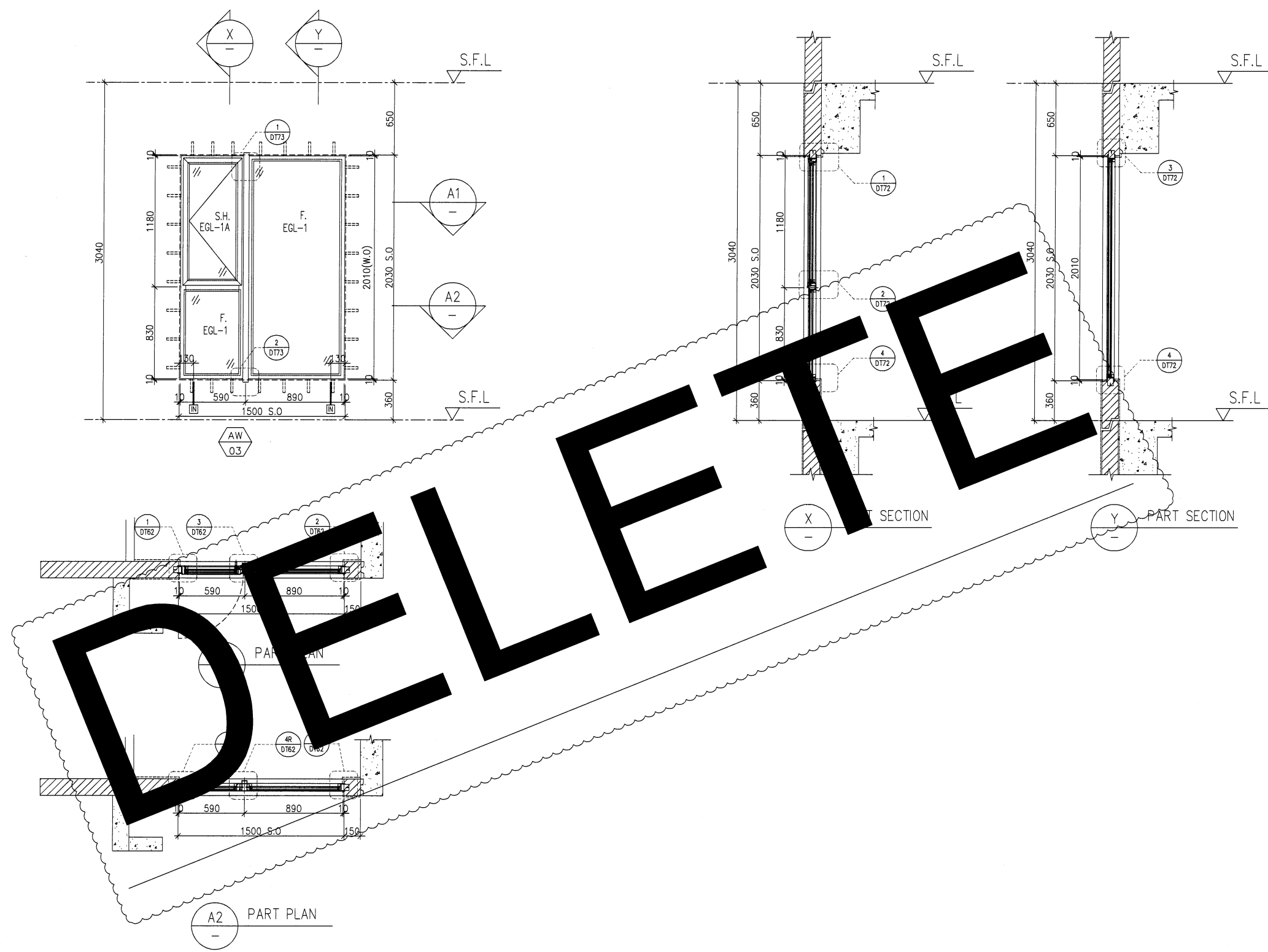

DELETE

FACADE CODE		
LWK	鴻輝	UNIT
PF-11	T2PF-??	B5

CHANGE TO IN-SITU WINDOWS

WINDOW MARK	AW 03
LOCATION	3/F-42/F(4/F,13/F,14/F,24/F,34/F OMITTED) UNIT B5
SECTION	70mm ALUM. SECTION
GLAZING	EGL-1,EGL-1A
QUANTITY	35 Nos
REMARKS	FACADE(TYPE T2PF11) FOR 3/F~42/F)

B.D. REF :

CLIENT :
SUN HUNG KAI
 REAL ESTATE AGENCY LTD.
 42/F SUN HUNG KAI CENTRE, WANCHAI, HONGKONG

ARCHITECT :
lwk&partners
 architects

MAIN CONTRACTOR :
怡輝建築有限公司
Yee Fal Building Contractors Ltd.

STRUCTURAL ENGINEER :
ARUP

FACADE CONSULTANT:
ALPHA CONSULTING LIMITED
 Steel Structure & Facade Specialist

NOTE :

- ALL DIMENSIONS ARE IN mm.
- ALL ELEVATIONS ARE VIEWED FROM OUTSIDE.
- ALL DIMENSIONS TO BE VERIFIED ON SITE BEFORE FABRICATION.

LEGEND :

(X1) — DETAIL MARK NO.
 (X001) — REFER SHEET NO.

- F.F.L. — FINISHED FLOOR LEVEL
- S.F.L. — STRUCTURAL FLOOR LEVEL
- (R) — REVERSED DETAIL
- GLASS LEGEND

EGL-1—8mmHS+12mm AIR GAP+10mmTP THK. I.G.U.
 EGL-2—10mm THK. CLEAR TEMPERED GLASS
 EGL-4—10mm THK. TEMPERED ACID ETCHED GLASS
 EGL-1A—8mmHS+12mm AIR GAP+8mmTP THK. I.G.U.

NO.	DATE	REVISION	BY
F	18/05/2022	REVISION SUBJECT TO ARCH.COMMENT	ivan
E	08/04/2022	REVISION SUBJECT TO ARCH.COMMENT	ivan
D	17/12/2021	REVISION SUBJECT TO ARCH.COMMENT	ivan
C	29/11/2021	REVISION SUBJECT TO ARCH.COMMENT	ivan
B	03/11/2021	REVISION SUBJECT TO ARCH.COMMENT	ivan
A	12/10/2021	REVISION SUBJECT TO ARCH.COMMENT	ivan

JOB NO. : J-856
 PROJECT :
 PROPOSED DEVELOPMENT ABOVE
 LIGHT RAIL TIN WING STOP,TSWTL
 NO.23,AREA 33,TIN SHUI WAI, N.T.

TITLE :
 WINDOW SCHEDULE FOR
 TOWER 2 ALUM. WINDOW

DATE : 02-Aug-21 SCALE : 1:40
 DRAWN BY : Ivan CHECKED BY :
美特鋁質有限公司
MIDI ALUMINIUM FABRICATOR LTD.
 Units 6-8, Sunray Industrial Centre, 1/F
 610 Cha Kwo Ling Road, Kowloon
 Tel:23489211-4 Fax:(852)2727666
 DWG NO. : J856-SD-PW-5210 REV. : F

ELEVATION

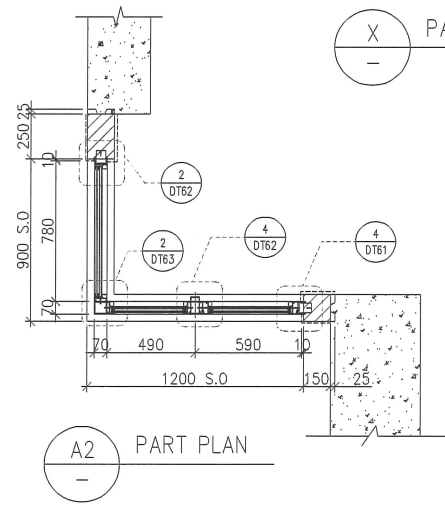
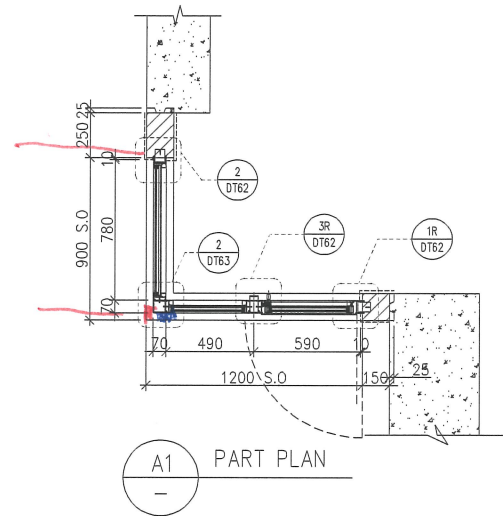
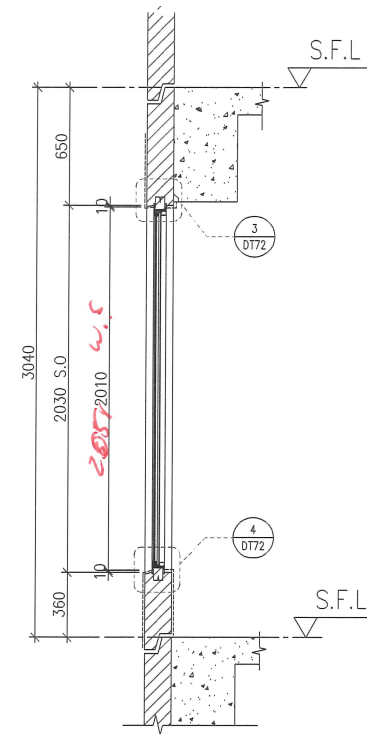
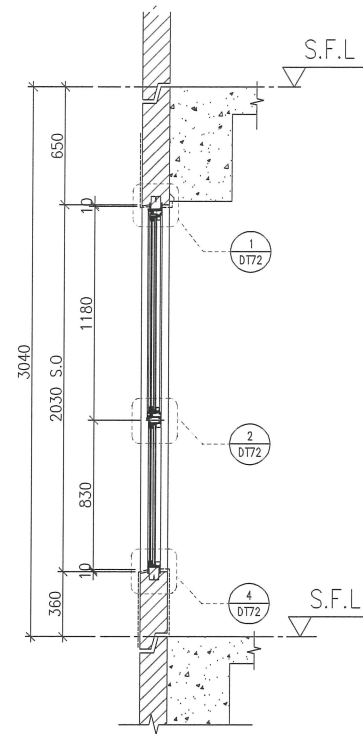
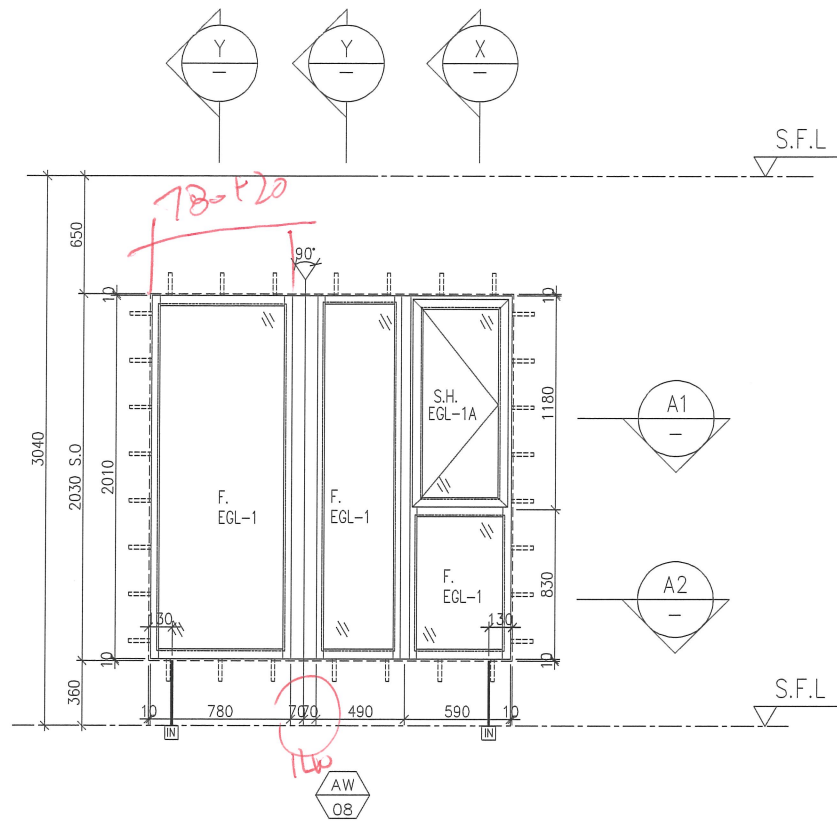

X PART SECTION

Y PART SECTION

A1 PART PLAN

A2 PART PLAN

FACADE CODE		
LWK	鴻輝	UNIT
PF-13	T2PF-27	B8

WINDOW MARK	AW 08
LOCATION	3/F-42/F(4/F,13/F,14/F,24/F,34/F OMITTED) UNIT B8
SECTION	70mm ALUM. SECTION
GLAZING	EGL-1,EGL-1A
QUANTITY	35 Nos
REMARKS	FACADE(TYPE T2PF13 FOR 3/F~42/F)

B.D. REF :

CLIENT :
SUN HUNG KAI
 REAL ESTATE AGENCY LTD.
 42/F SUN HUNG KAI CENTRE, WANCHAI, HONGKONG

ARCHITECT :
IWK&partners
 architects

MAIN CONTRACTOR :
Yee Fai Building Contractors Ltd.

STRUCTURAL ENGINEER :
ARUP

FACADE CONSULTANT:
ALPHA CONSULTING LIMITED
 Steel Structure & Facade Specialist

NOTE :
 1. ALL DIMENSIONS ARE IN mm.
 2. ALL ELEVATIONS ARE VIEWED FROM OUTSIDE.
 3. ALL DIMENSIONS TO BE VERIFIED ON SITE BEFORE FABRICATION.

LEGEND :
 (X1) --- DETAIL MARK NO.
 (X001) --- REFER SHEET NO.
 1. F.F.L. --- FINISHED FLOOR LEVEL
 2. S.F.L. --- STRUCTURAL FLOOR LEVEL
 3. (R) --- REVERSED DETAIL
 4. GLASS LEGEND
 EGL-1---8mmHS+12mm AIR GAP+10mmTP THK. I.G.U.
 EGL-2---10mm THK. CLEAR TEMPERED GLASS
 EGL-4---10mm THK. TEMPERED ACID ETCHED GLASS
 EGL-1A---8mmHS+12mm AIR GAP+8mmTP THK. I.G.U.

NO.	DATE	REVISED	BY
F	18/05/2022	REVISION SUBJECT TO ARCH.COMMENT	Ivan
E	08/04/2022	REVISION SUBJECT TO ARCH.COMMENT	Ivan
D	17/12/2021	REVISION SUBJECT TO ARCH.COMMENT	Ivan
C	29/11/2021	REVISION SUBJECT TO ARCH.COMMENT	Ivan
B	03/11/2021	REVISION SUBJECT TO ARCH.COMMENT	Ivan
A	12/10/2021	REVISION SUBJECT TO ARCH.COMMENT	Ivan

JOB NO. : J-856
 PROJECT :
 PROPOSED DEVELOPMENT ABOVE
 LIGHT RAIL TIN WING STOP, TSWTL
 NO.23, AREA 33, TIN SHUI WAI, N.T.

TITLE :
 WINDOW SCHEDULE FOR
 TOWER 2 ALUM. WINDOW

DATE : 02-Aug-21 SCALE : 1:40
 DRAWN BY : Ivan CHECKED BY :

英特鋁質有限公司
 MIDI ALUMINIUM FABRICATOR LTD.
 Units 6-8, Sunray Industrial Centre, 1/F
 610 Cha Kwo Ling Road, Kowloon
 Tel:23489211-4 Fax:(852)27727666

DWG NO. : J856-SD-PW-5211 REV. : F

ELEVATION

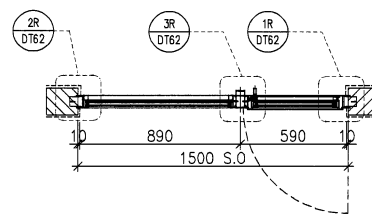
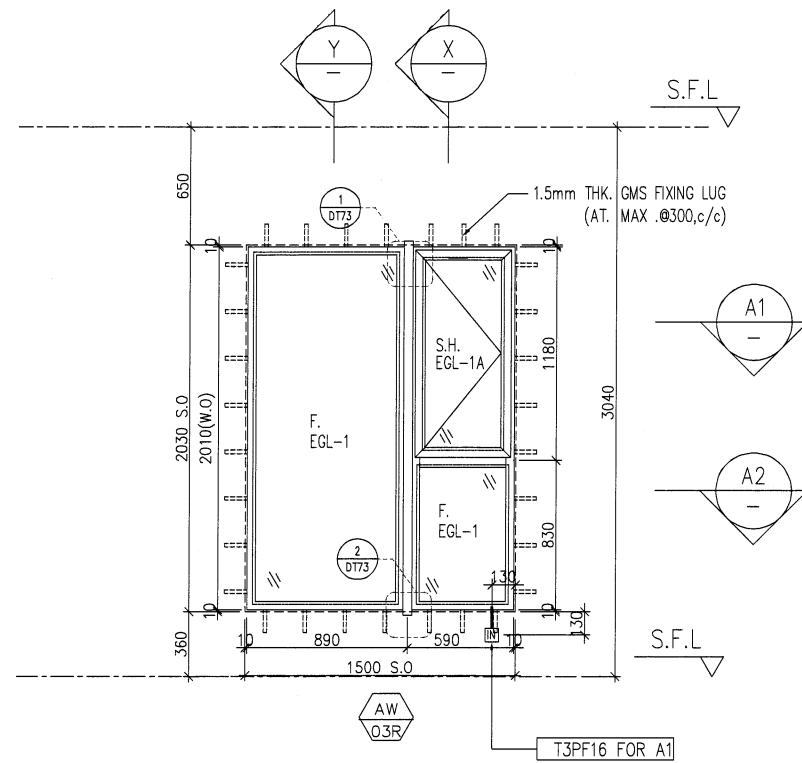

A1 PART PLAN

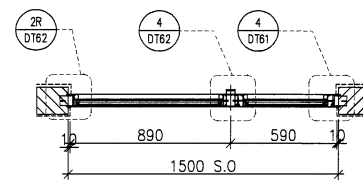

A2 PART PLAN

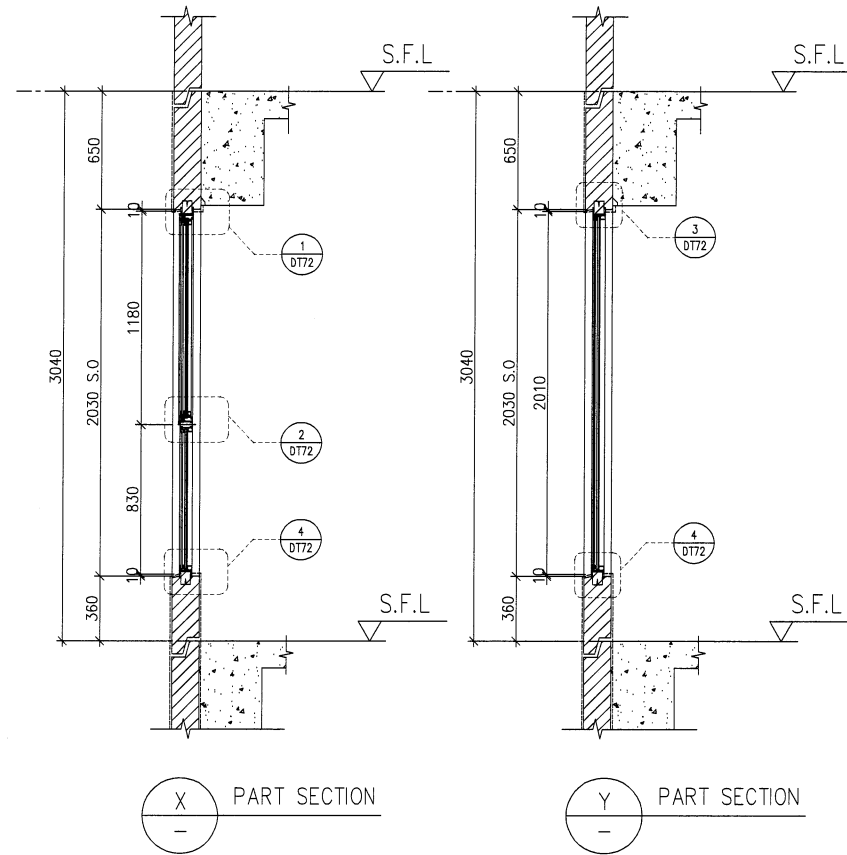

X PART SECTION

Y PART SECTION

FACADE CODE		
LWK	鴻輝	UNIT
PF-20R	T2PF-23	B6

WINDOW MARK	AW 03R
LOCATION	3/F-42/F(4/F,13/F,14/F,24/F,34/F OMITTED) UNIT B6
SECTION	70mm ALUM. SECTION
GLAZING	EGL-1,EGL-1A
QUANTITY	35 Nos
REMARKS	FACADE(TYPE T2PF20R FOR 3/F~42/F)

B.D. REF :

CLIENT :
SUN HUNG KAI
 REAL ESTATE AGENCY LTD.
 42/F SUN HUNG KAI CENTRE, WANCHAI, HONGKONG

ARCHITECT :
lwk&partners
 architects

MAIN CONTRACTOR :
怡輝建築有限公司
 Yee Fai Building Contractors Ltd.

STRUCTURAL ENGINEER :
ARUP

FACADE CONSULTANT:
ALPHA CONSULTING LIMITED
 Steel Structure & Facade Specialist

NOTE :
 1. ALL DIMENSIONS ARE IN mm.
 2. ALL ELEVATIONS ARE VIEWED FROM OUTSIDE.
 3. ALL DIMENSIONS TO BE VERIFIED ON SITE BEFORE FABRICATION.

LEGEND :
 X1 --- DETAIL MARK NO.
 X001 --- REFER SHEET NO.
 1. F.F.L. --- FINISHED FLOOR LEVEL
 2. S.F.L. --- STRUCTURAL FLOOR LEVEL
 3. (R) --- REVERSED DETAIL
 4. GLASS LEGEND
 EGL-1--8mmHS+12mm AIR GAP+10mmTP THK. I.G.U.
 EGL-2--10mm THK. CLEAR TEMPERED GLASS
 EGL-4--10mm THK. TEMPERED ACID ETCHED GLASS
 EGL-1A-8mmHS+12mm AIR GAP+8mmTP THK. I.G.U.

B	18/05/2022	REVISION SUBJECT TO ARCH.COMMENT	ivan
A	17/12/2021	REVISION SUBJECT TO ARCH.COMMENT	ivan
NO.	DATE	REVISED	BY

JOB NO. : J-856
 PROJECT : PROPOSED DEVELOPMENT ABOVE LIGHT RAIL TIN WING STOP,TSWTL NO.23,AREA 33,TIN SHUI WAI, N.T.

TITLE : WINDOW SCHEDULE FOR TOWER 2 ALUM. WINDOW

DATE : 02-Aug-21 SCALE : 1:40
 DRAWN BY : Ivan CHECKED BY :

美特鋁質有限公司
MIDI ALUMINIUM FABRICATOR LTD.
 Units 6-8, Sunray Industrial Centre, 1/F
 610 Cha Kwo Ling Road, Kowloon
 Tel:23489211-4 Fax:(852)2727666
 DWG NO. : J856-SD-PW-5212 REV. : B

ELEVATION

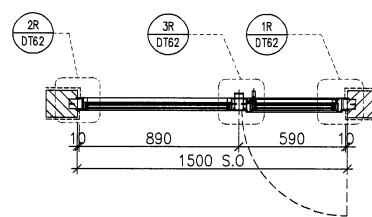
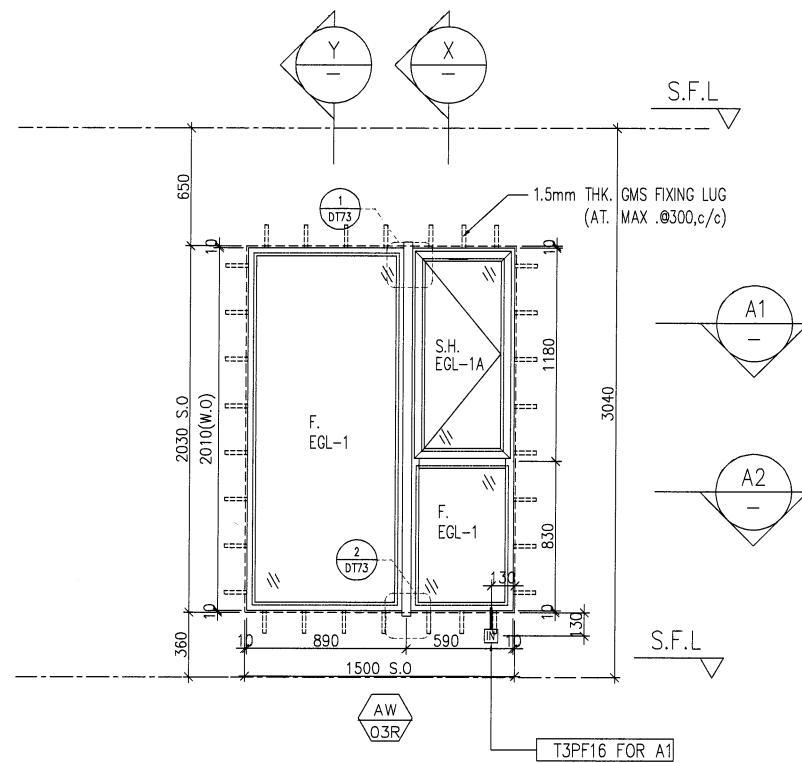

A1 PART PLAN

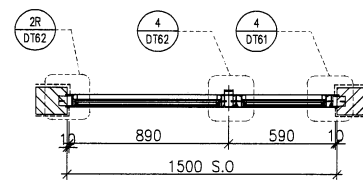

A2 PART PLAN

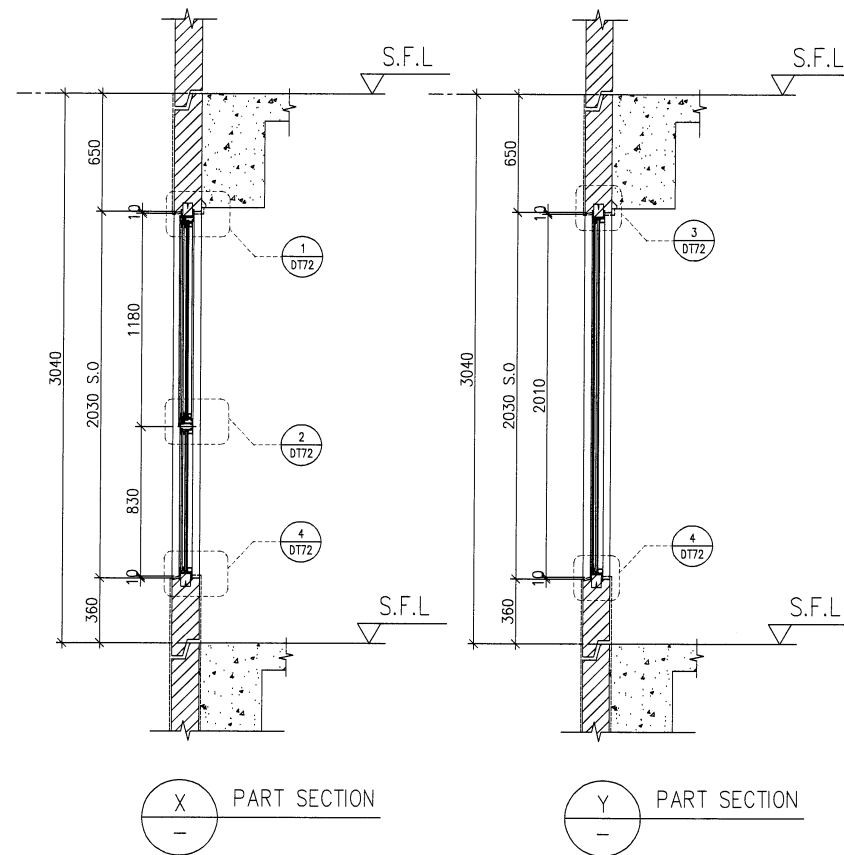

X PART SECTION

Y PART SECTION

FACADE CODE		
LWK	鴻輝	UNIT
PF-10	T2PF-03	B3

WINDOW MARK	AW 03R
LOCATION	3/F-42/F(4/F,13/F,14/F,24/F,34/F OMITTED) UNIT B3
SECTION	70mm ALUM. SECTION
GLAZING	EGL-1,EGL-1A
QUANTITY	35 Nos
REMARKS	FACADE(TYPE T2PF10R FOR 3/F~42/F)

B.D. REF :

CLIENT :
SUN HUNG KAI
 REAL ESTATE AGENCY LTD.
 42/F SUN HUNG KAI CENTRE, WANCHAI, HONGKONG

ARCHITECT :
lwk&partners
 architects

MAIN CONTRACTOR :
怡輝建築有限公司
Yee Fai Building Contractors Ltd.

STRUCTURAL ENGINEER :
ARUP

FACADE CONSULTANT :
ALPHA CONSULTING LIMITED
 Steel Structure & Facade Specialist

NOTE :
 1. ALL DIMENSIONS ARE IN mm.
 2. ALL ELEVATIONS ARE VIEWED FROM OUTSIDE.
 3. ALL DIMENSIONS TO BE VERIFIED ON SITE BEFORE FABRICATION.

LEGEND :
 X1 — DETAIL MARK NO.
 X001 — REFER SHEET NO.

1. F.F.L. — FINISHED FLOOR LEVEL
 2. S.F.L. — STRUCTURAL FLOOR LEVEL
 3. (R) — REVERSED DETAIL
 4. GLASS LEGEND
 EGL-1 — 8mmHS+12mm AIR GAP+10mmTP THK. I.G.U.
 EGL-2 — 10mm THK. CLEAR TEMPERED GLASS
 EGL-4 — 10mm THK. TEMPERED ACID ETCHED GLASS
 EGL-1A — 8mmHS+12mm AIR GAP+8mmTP THK. I.G.U.

NO.	DATE	REVISION	BY
A	18/05/2022	REVISION SUBJECT TO ARCH.COMMENT	Ivan

JOB NO. : J-856
 PROJECT : PROPOSED DEVELOPMENT ABOVE LIGHT RAIL TIN WING STOP, TSWTL NO.23, AREA 33, TIN SHUI WAI, N.T.

TITLE : WINDOW SCHEDULE FOR TOWER 2 ALUM. WINDOW

DATE : 08-Apr-21 SCALE : 1:40
 DRAWN BY : Ivan CHECKED BY :

美特鋁質有限公司
MIDI ALUMINIUM FABRICATOR LTD.
 Units 6-8, Sunray Industrial Centre, 1/F
 610 Cha Kwo Ling Road, Kowloon
 Tel:23489211-4 Fax:(852)27727666

DWG NO. : J856-SD-PW-5213 REV. : A

ELEVATION

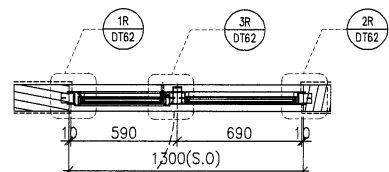
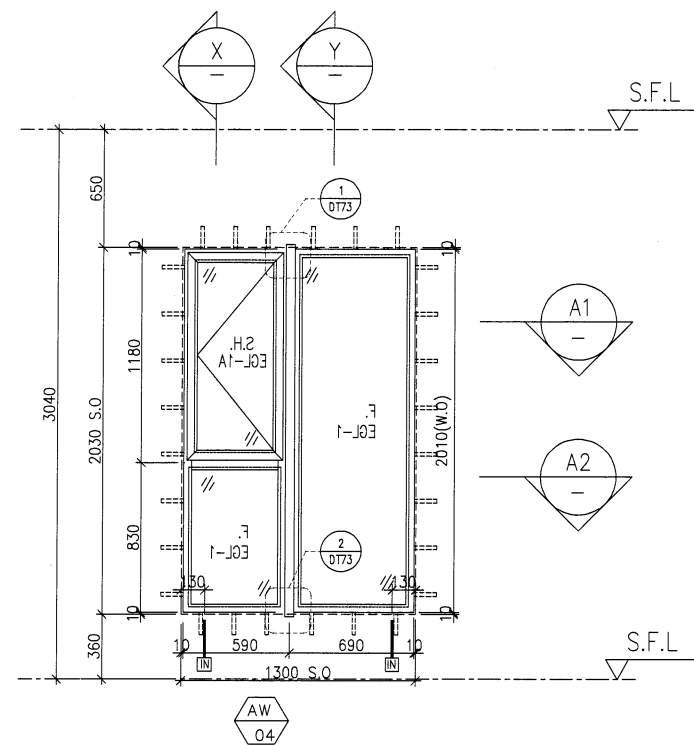

PART PLAN A1

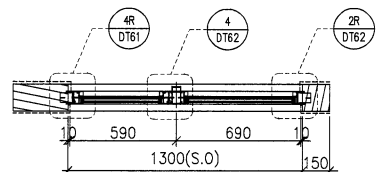

PART PLAN A2

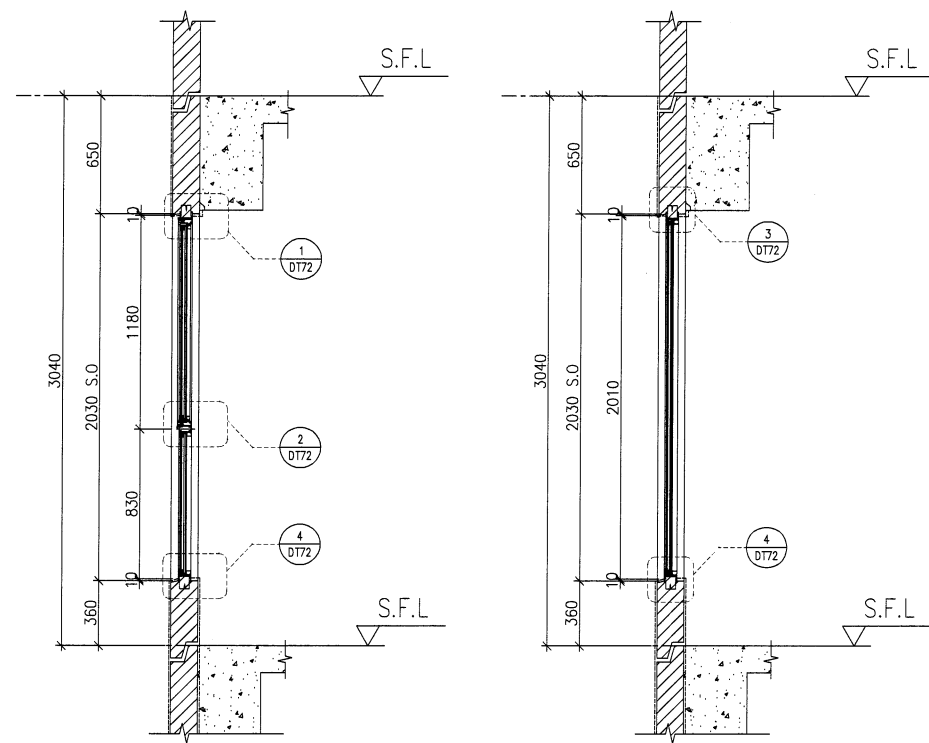

X PART SECTION

Y PART SECTION

FACADE CODE		
LWK	鴻輝	UNIT
PF-??R	T2PF-02A	B2

WINDOW MARK	AW 04
LOCATION	3/F-42/F(4/F,13/F,14/F,24/F,34/F OMITTED) UNIT B2
SECTION	70mm ALUM. SECTION
GLAZING	EGL-1,EGL-1A
QUANTITY	35 Nos
REMARKS	FACADE(TYPE T2PF??R FOR 3/F~42/F)

B.D. REF :

CLIENT :
SUN HUNG KAI
 REAL ESTATE AGENCY LTD.
 42/F SUN HUNG KAI CENTRE, WANCHAI, HONGKONG

ARCHITECT :
lwk&partners
 architects

MAIN CONTRACTOR :
Yee Fai Building Contractors Ltd.

STRUCTURAL ENGINEER :
ARUP

FACADE CONSULTANT:
ALPHA CONSULTING LIMITED
 Steel Structure & Facade Specialist

NOTE :
 1. ALL DIMENSIONS ARE IN mm.
 2. ALL ELEVATIONS ARE VIEWED FROM OUTSIDE.
 3. ALL DIMENSIONS TO BE VERIFIED ON SITE BEFORE FABRICATION.

LEGEND :
 x1 ————DETAIL MARK NO.
 x001 ———REFER SHEET NO.

1. F.F.L. --FINISHED FLOOR LEVEL
 2. S.F.L. --STRUCTURAL FLOOR LEVEL
 3. (R) --REVERSED DETAIL
 4. GLASS LEGEND
 EGL-1--8mmHS+12mm AIR GAP+10mmTP THK. I.G.U.
 EGL-2--10mm THK. CLEAR TEMPERED GLASS
 EGL-4--10mm THK. TEMPERED ACID ETCHED GLASS
 EGL-1A-8mmHS+12mm AIR GAP+8mmTP THK. I.G.U.

B	18/05/2022	REVISION SUBJECT TO ARCH.COMMENT	Ivan
A	17/12/2021	REVISION SUBJECT TO ARCH.COMMENT	Ivan
NO.	DATE	REVISED	BY

JOB NO. : J-856
 PROJECT :
 PROPOSED DEVELOPMENT ABOVE
 LIGHT RAIL TIN WING STOP,TSWTL
 NO.23,AREA 33,TIN SHUI WAI, N.T.

TITLE :
 WINDOW SCHEDULE FOR
 TOWER 2 ALUM. WINDOW

DATE : 08-Apr-21 SCALE : 1:40
 DRAWN BY : Ivan CHECKED BY :

英特鋁質有限公司
MIDI ALUMINIUM FABRICATOR LTD.
 Units 6-8, Sunray Industrial Centre, 1/F
 610 Cha Kwo Ling Road, Kowloon
 Tel:23489211-4 Fax:(852)27727666
 DWG NO. : J856-SD-PW-5214 REV. : B

ELEVATION

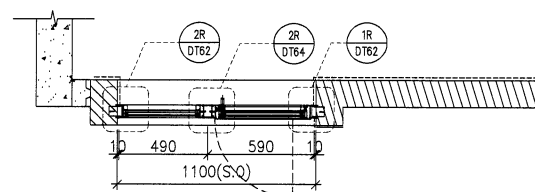
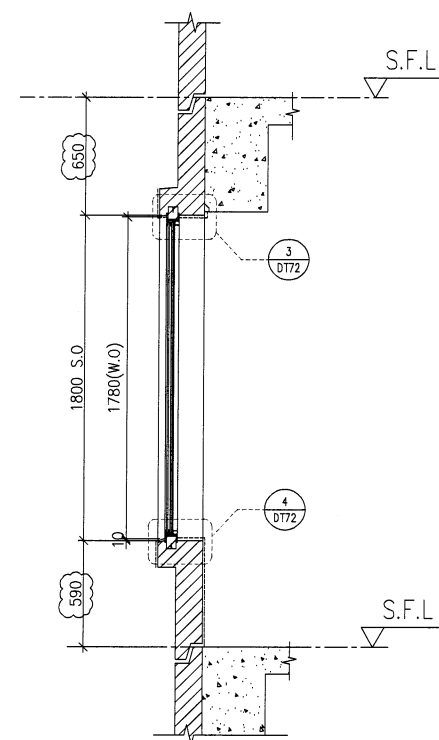
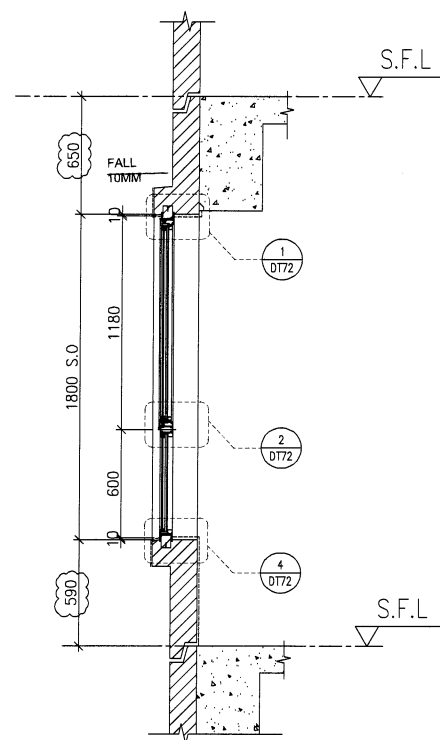
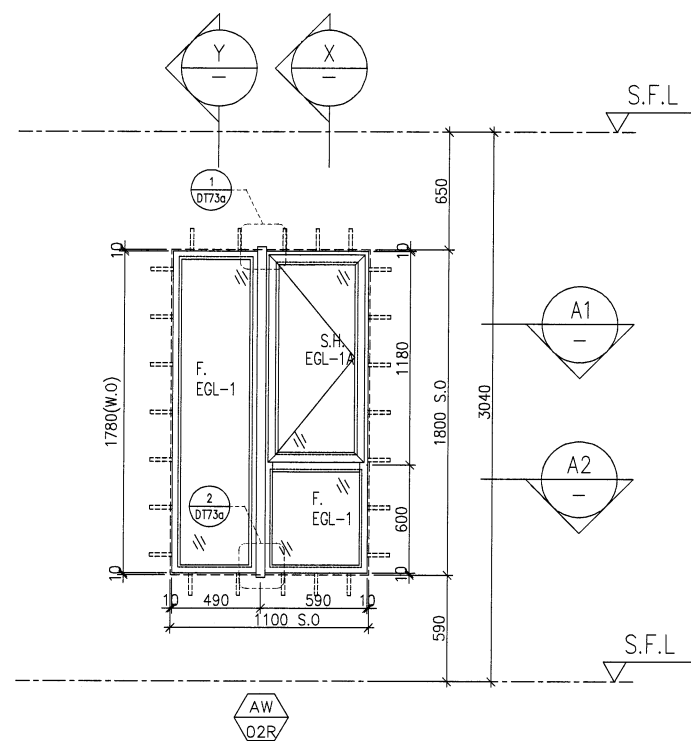

A1 PART PLAN

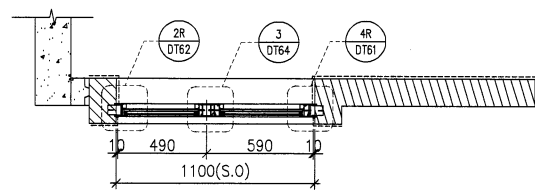

A2 PART PLAN

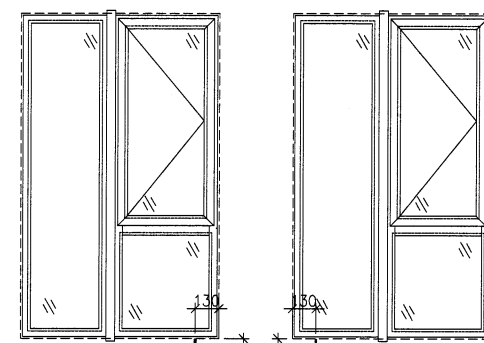

T3PF02R FOR A9
T3PF02R FOR B8
T3PF02R FOR B7
T3PF02R FOR A2

FACADE CODE		
LWK	鴻輝	UNIT
PF-02R	T3PF-05	A2
PF-02R	T3PF-37	A9
PF-02R	T3PF-31	B7
PF-02R	T3PF-32	B8

WINDOW MARK	AW 02R
LOCATION	3/F-42/F(4/F,13/F,14/F,24/F,34/F OMITTED) (UNIT A2,A9,B7,B8)
SECTION	70mm ALUM. SECTION
GLAZING	EGL-1,EGL-1A
QUANTITY	{35 Nos / 35 Nos / 35 Nos / 35 Nos}
REMARKS	FACADE(TYPE {T3PF02R} FOR 3/F~42/F)

B.D. REF :

CLIENT :

SUN HUNG KAI
REAL ESTATE AGENCY LTD.
42/F SUN HUNG KAI CENTRE, WANCHAI, HONGKONG

ARCHITECT :

lwk&partners
architects

MAIN CONTRACTOR :

Yee Fai Building Contractors Ltd.

STRUCTURAL ENGINEER :

ARUP

FACADE CONSULTANT:

ALPHA CONSULTING LIMITED
Steel Structure & Facade Specialist

NOTE :

1. ALL DIMENSIONS ARE IN mm.
2. ALL ELEVATIONS ARE VIEWED FROM OUTSIDE.
3. ALL DIMENSIONS TO BE VERIFIED ON SITE BEFORE FABRICATION.

LEGEND :

- X1 — DETAIL MARK NO.
- X001 — REFER SHEET NO.

1. F.F.L. -- FINISHED FLOOR LEVEL
2. S.F.L. -- STRUCTURAL FLOOR LEVEL
3. (R) -- REVERSED DETAIL
4. GLASS LEGEND

EGL-1--8mmHS+12mm AIR GAP+10mmTP THK. I.G.U.
EGL-2--10mm THK. CLEAR TEMPERED GLASS
EGL-4--10mm THK. TEMPERED ACID ETCHED GLASS
EGL-1A--8mmHS+12mm AIR GAP+8mmTP THK. I.G.U.

NO.	DATE	REVISION	BY
G	22/04/2022	REVISION SUBJECT TO ARCH.COMMENT	Ivan
F	08/04/2022	REVISION SUBJECT TO ARCH.COMMENT	Ivan
E	14/12/2021	REVISION SUBJECT TO ARCH.COMMENT	Ivan
D	29/11/2021	REVISION SUBJECT TO ARCH.COMMENT	Ivan
C	02/11/2021	REVISION SUBJECT TO ARCH.COMMENT	Ivan
B	28/10/2021	REVISION SUBJECT TO ARCH.COMMENT	Ivan
A	18/10/2021	REVISION SUBJECT TO ARCH.COMMENT	Ivan

JOB NO. : J-856

PROJECT :
PROPOSED DEVELOPMENT ABOVE
LIGHT RAIL TIN WING STOP,TSWTL
NO.23,AREA 33,TIN SHUI WAI, N.T.

TITLE :
WINDOW SCHEDULE FOR
TOWER 3 ALUM. WINDOW

DATE : 02-Aug-21 SCALE : 1:40

DRAWN BY : Ivan CHECKED BY :

英特鋁質有限公司
MIDI ALUMINIUM FABRICATOR LTD.
Units 6-8, Sunray Industrial Centre, 1/F
610 Cha Kwo Ling Road, Kowloon
Tel:23489211-4 Fax:(852)2727666

DWG NO. : J856-SD-PW-5301 REV. : G

ELEVATION

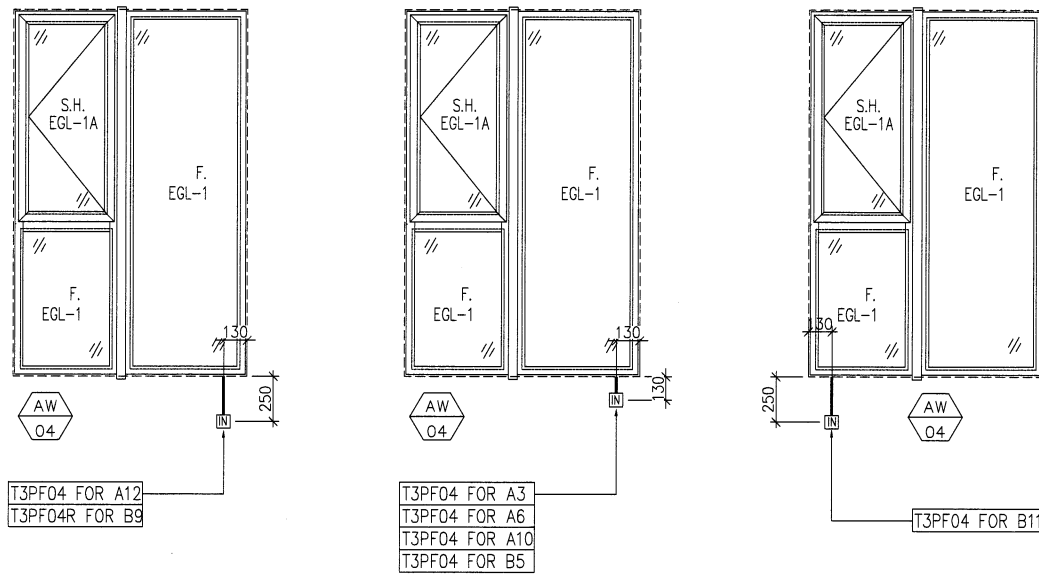
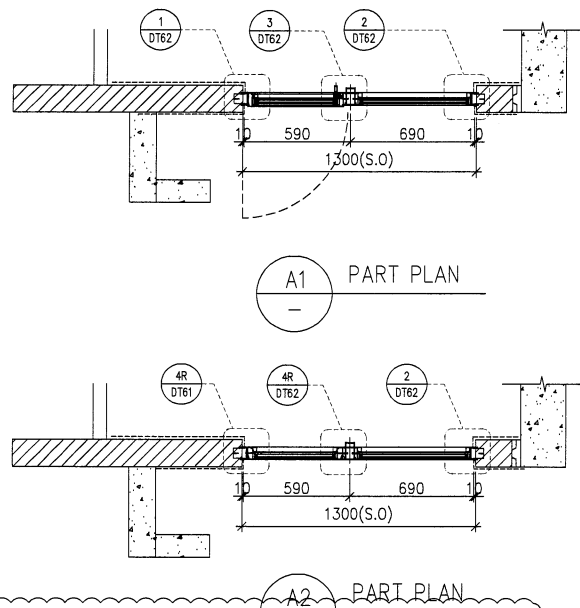
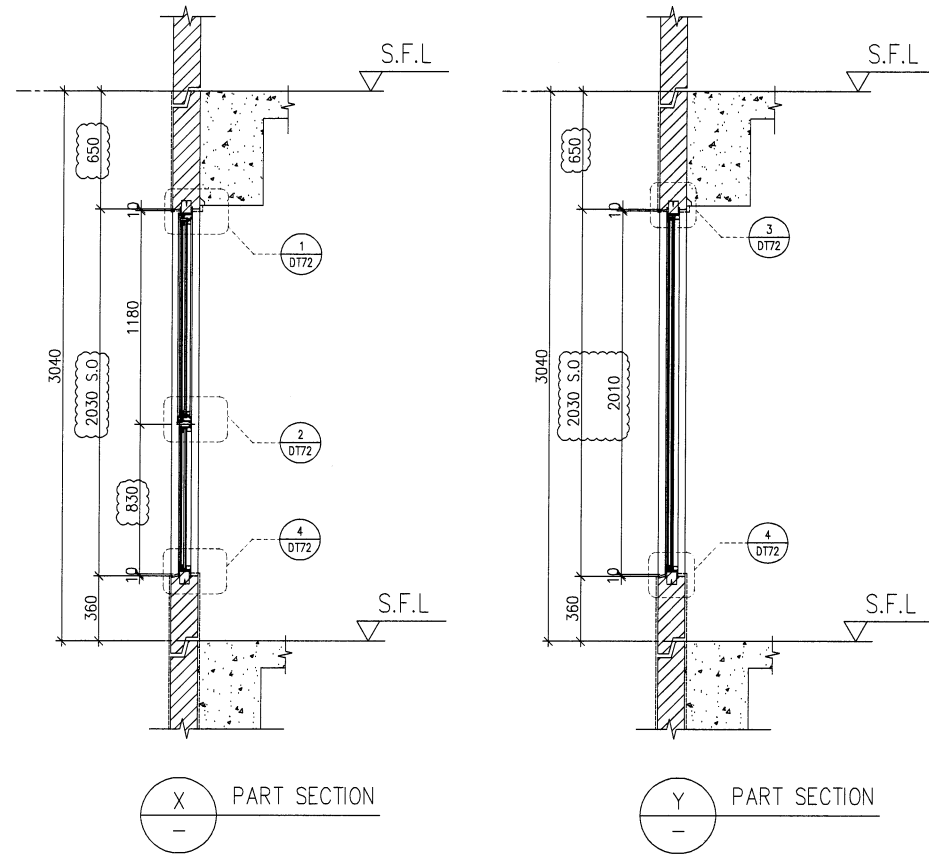
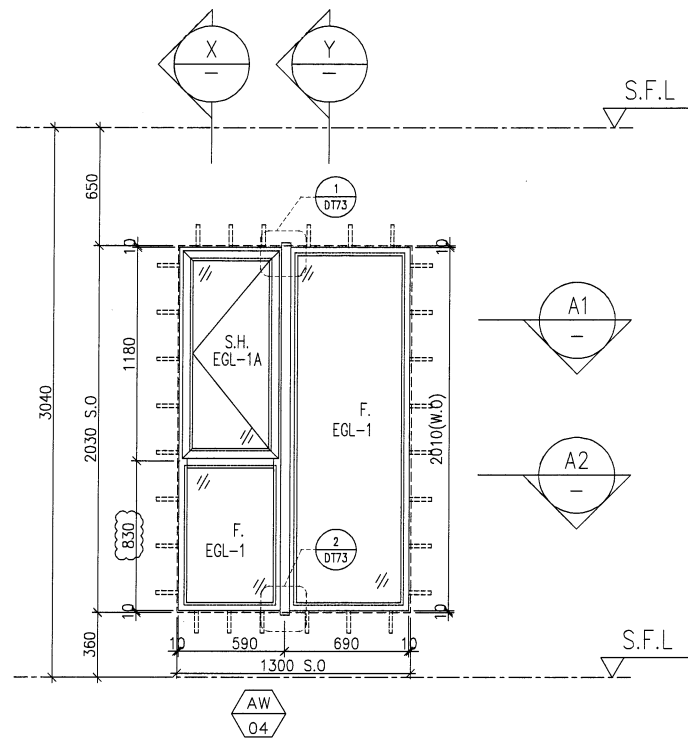

FACADE CODE			FACADE CODE		
LWK	鴻輝	UNIT	LWK	鴻輝	UNIT
PF-04	T3PF-08	A3	PF-04	T3PF-26	B5
PF-04	T3PF-12	A6	PF-04	T3PF-33	B9
PF-04	T3PF-39A	A10	PF-04R	T3PF-19	B11
PF-04	T3PF-42	A12			

WINDOW MARK	AW 04
LOCATION	3/F-42/F(4/F,13/F,14/F,24/F,34/F OMITTED) (UNIT A3, A6, A10, A12, B5, B9, B11)
SECTION	70mm ALUM. SECTION
GLAZING	EGL-1, EGL-1A
QUANTITY	35 Nos / 35 Nos / 35 Nos / 35 Nos / 35 Nos / 35 Nos / 35 Nos
REMARKS	FACADE(TYPE T3PF04/04R) FOR 3/F~42/F

B.D. REF :

CLIENT :
SUN HUNG KAI
 REAL ESTATE AGENCY LTD.
 42/F SUN HUNG KAI CENTRE, WANCHAI, HONGKONG

ARCHITECT :
IWK&partners
 architects

MAIN CONTRACTOR :
Yee Fal Building Contractors Ltd.

STRUCTURAL ENGINEER :
ARUP

FACADE CONSULTANT:
ALPHA CONSULTING LIMITED
 Steel Structure & Facade Specialist

NOTE :
 1. ALL DIMENSIONS ARE IN mm.
 2. ALL ELEVATIONS ARE VIEWED FROM OUTSIDE.
 3. ALL DIMENSIONS TO BE VERIFIED ON SITE BEFORE FABRICATION.

LEGEND :
 (X1) — DETAIL MARK NO.
 (X001) — REFER SHEET NO.
 1. F.F.L. — FINISHED FLOOR LEVEL
 2. S.F.L. — STRUCTURAL FLOOR LEVEL
 3. (R) — REVERSED DETAIL
 4. GLASS LEGEND
 EGL-1 — 8mmHS+12mm AIR GAP+10mmTP THK. I.G.U.
 EGL-2 — 10mm THK. CLEAR TEMPERED GLASS
 EGL-4 — 10mm THK. TEMPERED ACID ETCHED GLASS
 EGL-1A — 8mmHS+12mm AIR GAP+8mmTP THK. I.G.U.

NO.	DATE	REVISION	BY
H	22/04/2022	REVISION SUBJECT TO ARCH.COMMENT	Ivan
G	08/04/2022	REVISION SUBJECT TO ARCH.COMMENT	Ivan
F	14/12/2021	REVISION SUBJECT TO ARCH.COMMENT	Ivan
E	29/11/2021	REVISION SUBJECT TO ARCH.COMMENT	Ivan
D	02/11/2021	REVISION SUBJECT TO ARCH.COMMENT	Ivan
C	28/10/2021	REVISION SUBJECT TO ARCH.COMMENT	Ivan
B	18/10/2021	REVISION SUBJECT TO ARCH.COMMENT	Ivan
A	27/09/2021	REVISION SUBJECT TO ARCH.COMMENT	Ivan

JOB NO. : J-856
 PROJECT : PROPOSED DEVELOPMENT ABOVE LIGHT RAIL TIN WING STOP, TSWTL NO.23, AREA 33, TIN SHUI WAI, N.T.

TITLE : WINDOW SCHEDULE FOR TOWER 3 ALUM. WINDOW

DATE : 02-Aug-21 SCALE : 1:40
 DRAWN BY : Ivan CHECKED BY :

MIDI ALUMINIUM FABRICATOR LTD.
 Units 6-8, Sunray Industrial Centre, 1/F
 610 Cho Kwo Ling Road, Kowloon
 Tel: 23489211-4 Fax: (852) 27727666
 DWG NO. : J856-SD-PW-5302 REV. : H

ELEVATION

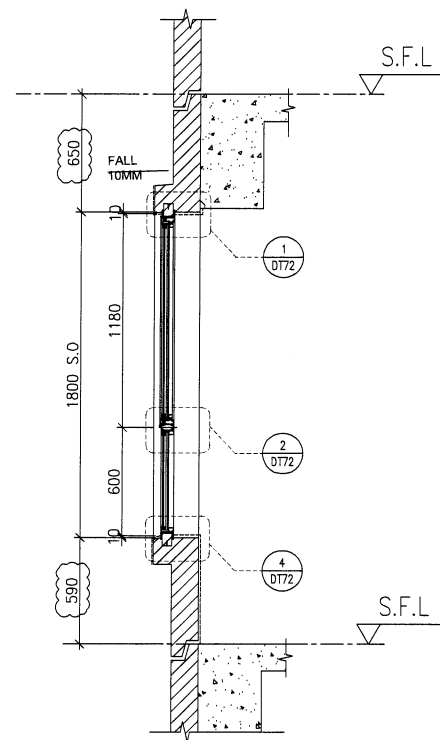
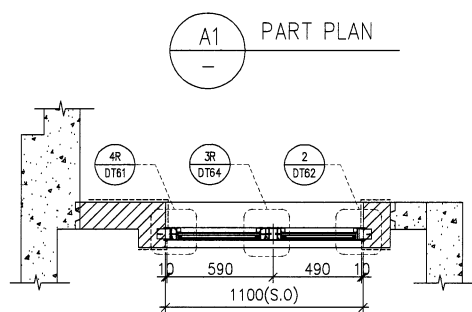
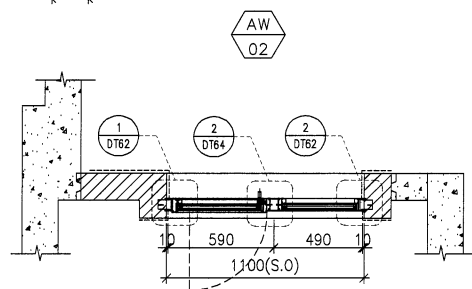
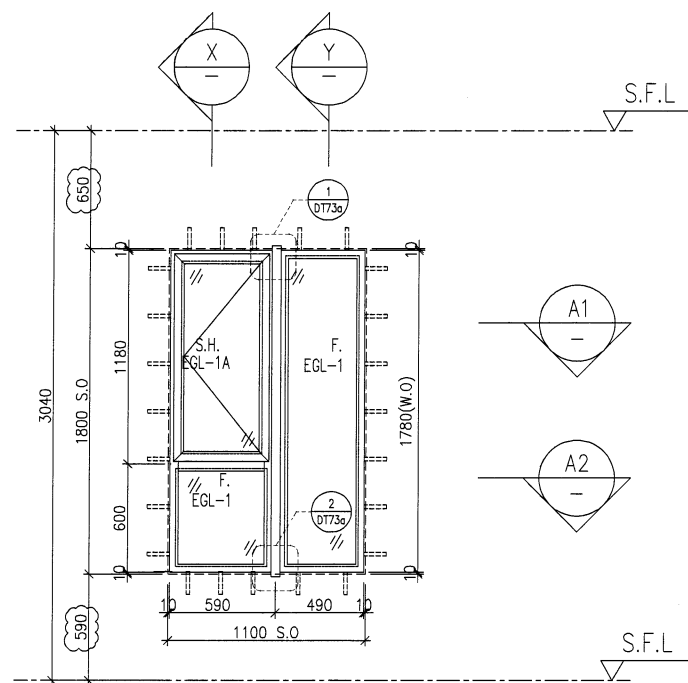

X PART SECTION

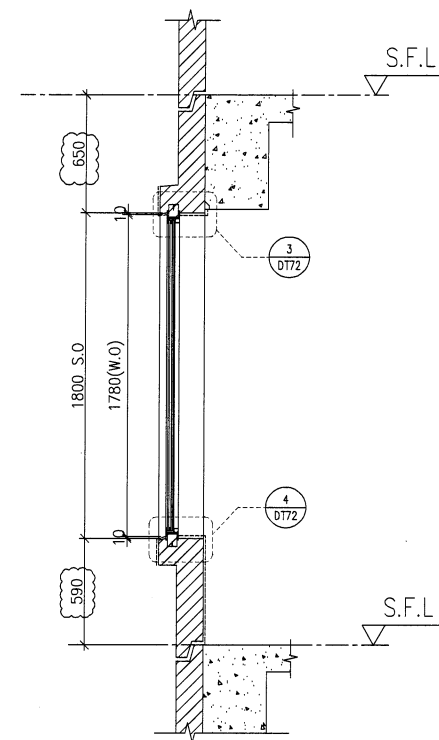

Y PART SECTION

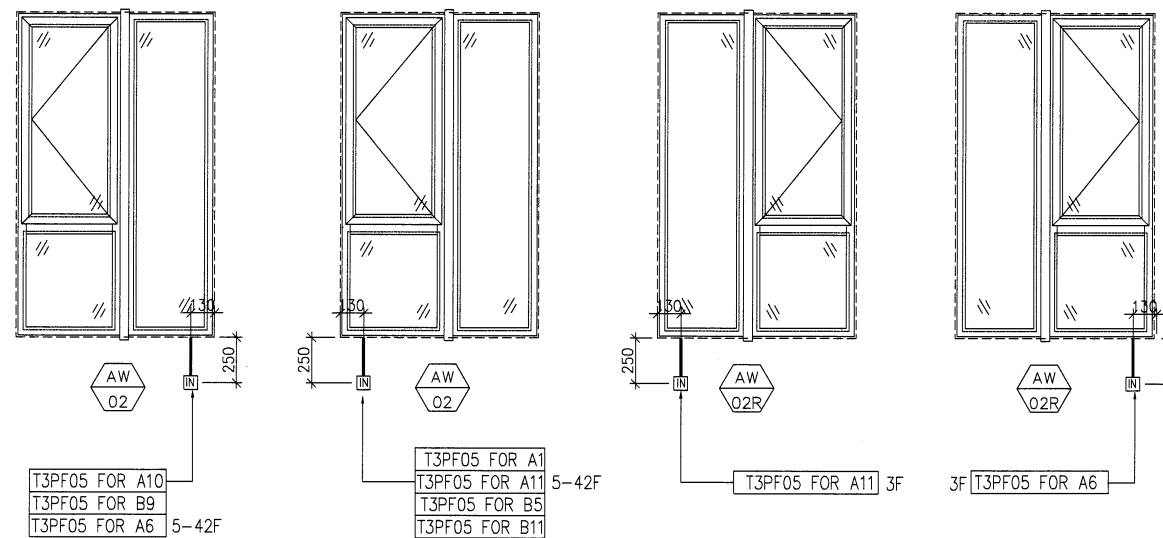

FACADE CODE			FACADE CODE		
LWK	鴻輝	UNIT	LWK	鴻輝	UNIT
PF-05	T3PF-04	A1	PF-05	T3PF-27	B5
PF-05	T3PF-13	A6	PF-05	T3PF-34	B9
PF-05	T3PF-39	A10	PF-05	T3PF-18	B11
PF-05	T3PF-40	A11			

WINDOW MARK



LOCATION 3/F-42/F(4/F,13/F,14/F,24/F,34/F OMITTED) UNIT A1, {A6(5-42F)}, A10, {A11(5-42F)}, B5, B9, B11

SECTION 70mm ALUM. SECTION

GLAZING EGL-1,EGL-1A

QUANTITY 35 Nos / {34 Nos} / 35 Nos / {34 Nos} / 35 Nos / 35 Nos / 35 Nos

REMARKS FACADE(TYPE {T3PF05}) FOR 3/F~42/F



3/F UNIT A6(3F), A11(3F)

70mm ALUM. SECTION

EGL-1,EGL-1A

1 No / 1 No

FACADE(TYPE T3PF05R FOR 3/F~42/F)

B.D. REF :

CLIENT :

SUN HUNG KAI
REAL ESTATE AGENCY LTD.
42/F SUN HUNG KAI CENTRE, WANCHAI, HONGKONG

ARCHITECT :

lwk&partners
architects

MAIN CONTRACTOR :

Yee Fai Building Contractors Ltd.

STRUCTURAL ENGINEER :

ARUP

FACADE CONSULTANT:

ALPHA CONSULTING LIMITED
Steel Structure & Facade Specialist

NOTE :

1. ALL DIMENSIONS ARE IN mm.
2. ALL ELEVATIONS ARE VIEWED FROM OUTSIDE.
3. ALL DIMENSIONS TO BE VERIFIED ON SITE BEFORE FABRICATION.

LEGEND :

- X1 — DETAIL MARK NO.
- X001 — REFER SHEET NO.

1. F.F.L. — FINISHED FLOOR LEVEL
2. S.F.L. — STRUCTURAL FLOOR LEVEL
3. (R) — REVERSED DETAIL
4. GLASS LEGEND

EGL-1—8mmHS+12mm AIR GAP+10mmTP THK. I.G.U.
EGL-2—10mm THK. CLEAR TEMPERED GLASS
EGL-4—10mm THK. TEMPERED ACID ETCHED GLASS
EGL-1A—8mmHS+12mm AIR GAP+8mmTP THK. I.G.U.

NO.	DATE	REVISION	BY
H	22/04/2022	REVISION SUBJECT TO ARCH.COMMENT	ivan
G	08/04/2022	REVISION SUBJECT TO ARCH.COMMENT	ivan
F	14/12/2021	REVISION SUBJECT TO ARCH.COMMENT	ivan
E	29/11/2021	REVISION SUBJECT TO ARCH.COMMENT	ivan
D	02/11/2021	REVISION SUBJECT TO ARCH.COMMENT	ivan
C	28/10/2021	REVISION SUBJECT TO ARCH.COMMENT	ivan
B	18/10/2021	REVISION SUBJECT TO ARCH.COMMENT	ivan
A	27/09/2021	REVISION SUBJECT TO ARCH.COMMENT	ivan

JOB NO. : J-856

PROJECT : PROPOSED DEVELOPMENT ABOVE LIGHT RAIL TIN WING STOP,TSWTL NO.23,AREA 33,TIN SHUI WAI, N.T.

TITLE : WINDOW SCHEDULE FOR TOWER 3 ALUM. WINDOW

DATE : 02-Aug-21 SCALE : 1:40

DRAWN BY : Ivan CHECKED BY :

美特鋁質有限公司
MIDI ALUMINIUM FABRICATOR LTD.
Units 6-8, Sunray Industrial Centre, 1/F
610 Cha Kwo Ling Road, Kowloon
Tel:23489211-4 Fax:(852)27272666

DWG NO. : J856-SD-PW-5303 REV. : H

ELEVATION

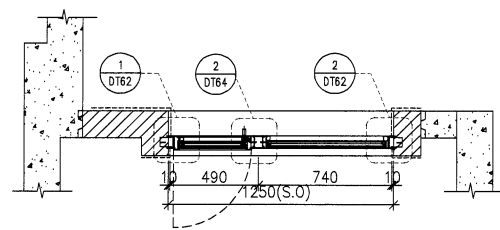
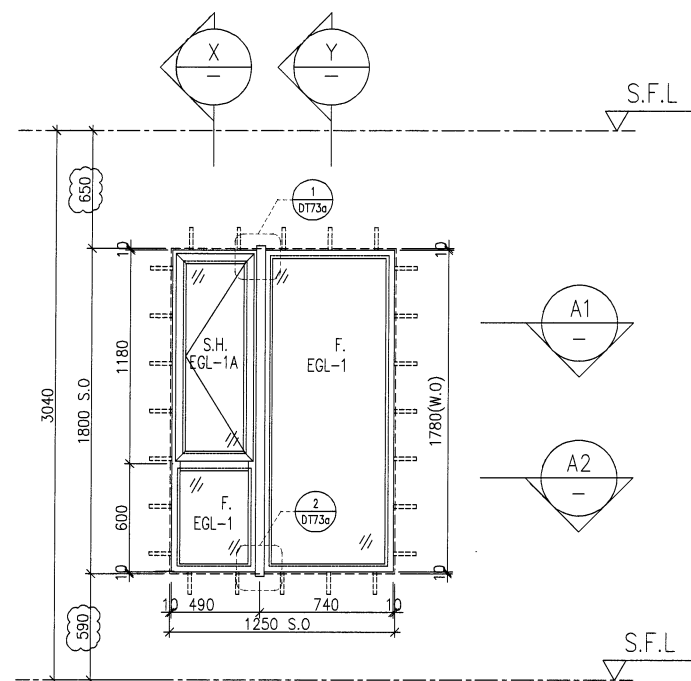

A1 PART PLAN

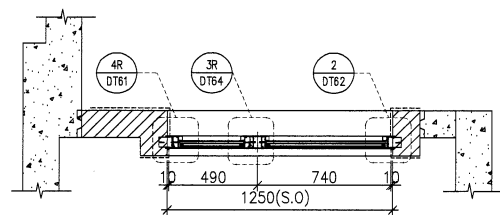

A2 PART PLAN

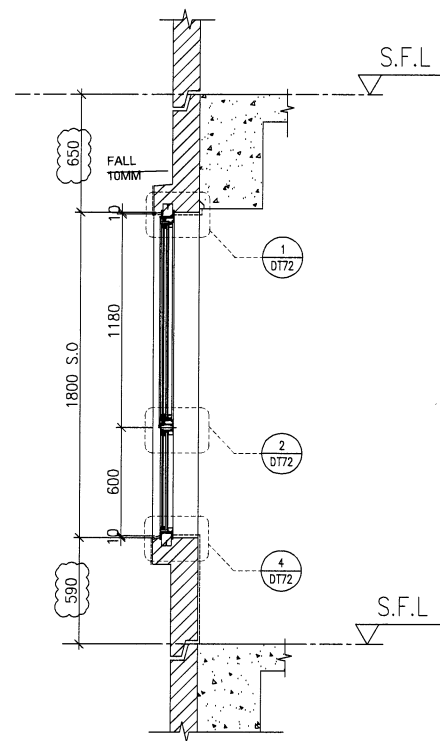

X PART SECTION

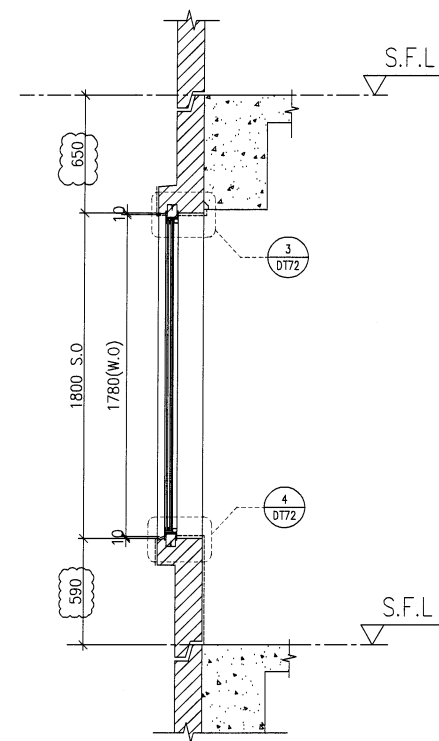

Y PART SECTION

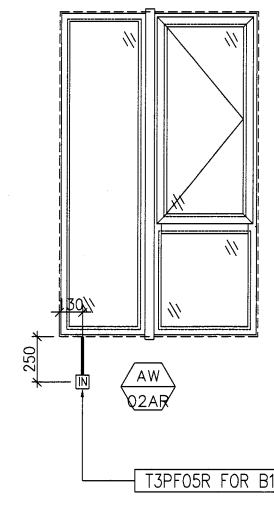
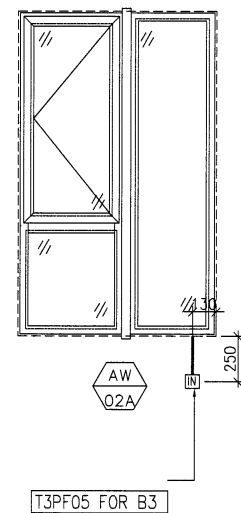

FACADE CODE		
LWK	鴻輝	UNIT
PF-05	T3PF-24	B3
PF-05R	T3PF-21	B1

WINDOW MARK	AW Q2a
LOCATION	3/F-42/F(4/F,13/F,14/F,24/F,34/F OMITTED) UNIT B3
SECTION	70mm ALUM. SECTION
GLAZING	EGL-1,EGL-1A
QUANTITY	35 Nos
REMARKS	FACADE(TYPE T3PF05 FOR 3/F~42/F)

WINDOW MARK	AW Q2aR
LOCATION	3/F-42/F(4/F,13/F,14/F,24/F,34/F OMITTED) UNIT B1
SECTION	70mm ALUM. SECTION
GLAZING	EGL-1,EGL-1A
QUANTITY	35 Nos
REMARKS	FACADE(TYPE T3PF05R FOR 3/F~42/F)

B.D. REF :

CLIENT :
SUN HUNG KAI
 REAL ESTATE AGENCY LTD.
 42/F SUN HUNG KAI CENTRE, WANCHAI, HONGKONG

ARCHITECT :
lwk&partners
 architects

MAIN CONTRACTOR :
Yee Fai Building Contractors Ltd.

STRUCTURAL ENGINEER :
ARUP

FACADE CONSULTANT:
ALPHA CONSULTING LIMITED
 Steel Structure & Facade Specialist

NOTE:
 1. ALL DIMENSIONS ARE IN mm.
 2. ALL ELEVATIONS ARE VIEWED FROM OUTSIDE.
 3. ALL DIMENSIONS TO BE VERIFIED ON SITE BEFORE FABRICATION.

LEGEND:
 x1 — DETAIL MARK NO.
 x001 — REFER SHEET NO.
 1. F.F.L. — FINISHED FLOOR LEVEL
 2. S.F.L. — STRUCTURAL FLOOR LEVEL
 3. (R) — REVERSED DETAIL
 4. GLASS LEGEND
 EGL-1—8mmHS+12mm AIR GAP+10mmTP THK. I.G.U.
 EGL-2—10mm THK. CLEAR TEMPERED GLASS
 EGL-4—10mm THK. TEMPERED ACID ETCHED GLASS
 EGL-1A—8mmHS+12mm AIR GAP+8mmTP THK. I.G.U.

NO.	DATE	REVISED	BY
-----	------	---------	----

JOB NO. : J-856
 PROJECT : PROPOSED DEVELOPMENT ABOVE LIGHT RAIL TIN WING STOP, TSWTL NO.23, AREA 33, TIN SHUI WAI, N.T.

TITLE : WINDOW SCHEDULE FOR TOWER 3 ALUM. WINDOW

DATE : 22-Apr-22 SCALE : 1:40
 DRAWN BY : Ivan CHECKED BY :

美特鋁質有限公司
MIDI ALUMINIUM FABRICATOR LTD.
 Units 6-8, Sunray Industrial Centre, 1/F
 610 Cha Kwo Ling Road, Kowloon
 Tel:23489211-4 Fax:(852)27727666
 DWG NO. : J856-SD-PW-5303a REV. : -

ELEVATION

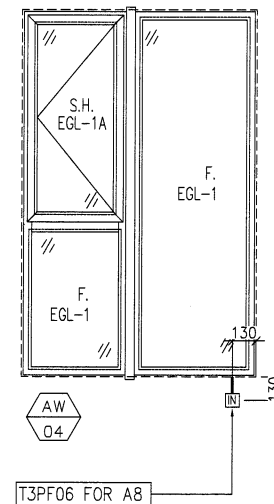
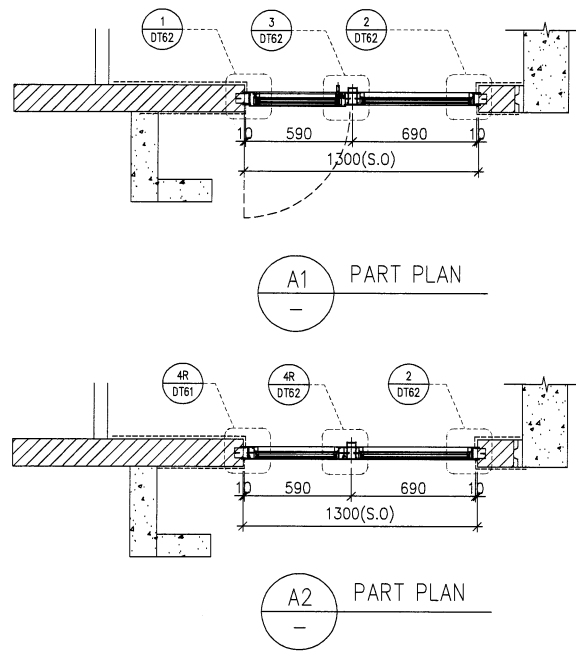
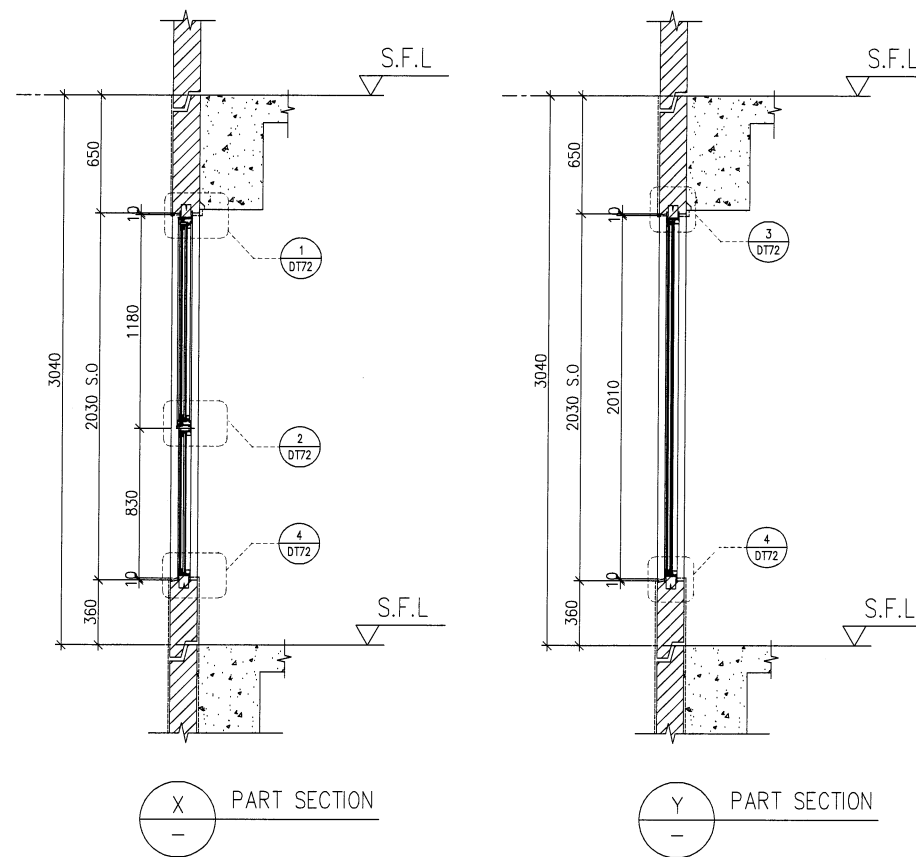
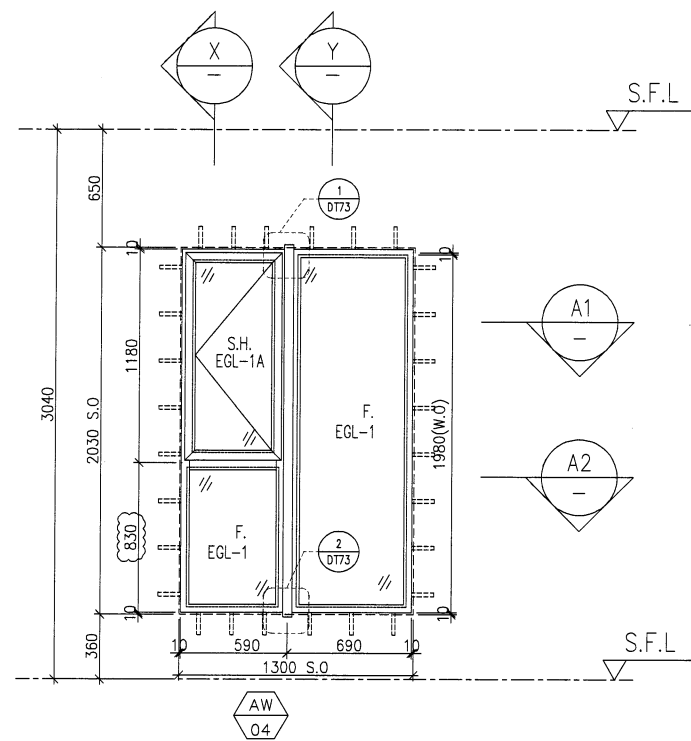

FACADE CODE		
LWK	鴻輝	UNIT
PF-06	T3PF-36	A8

WINDOW MARK	AW 04
LOCATION	3/F-42/F(4/F,13/F,14/F,24/F,34/F OMITTED) UNIT A8
SECTION	70mm ALUM. SECTION
GLAZING	EGL-1,EGL-1A
QUANTITY	35 Nos
REMARKS	FACADE(TYPE T3PF06 FOR 3/F~42/F)

B.D. REF :

CLIENT :
SUN HUNG KAI
 REAL ESTATE AGENCY LTD.
 42/F SUN HUNG KAI CENTRE, WANCHAI, HONGKONG

ARCHITECT :
lwk&partners
 architects

MAIN CONTRACTOR :
怡輝建築有限公司
 Yee Fai Building Contractors Ltd.

STRUCTURAL ENGINEER :
ARUP

FACADE CONSULTANT:
ALPHA CONSULTING LIMITED
 Steel Structure & Facade Specialist

NOTE :
 1. ALL DIMENSIONS ARE IN mm.
 2. ALL ELEVATIONS ARE VIEWED FROM OUTSIDE.
 3. ALL DIMENSIONS TO BE VERIFIED ON SITE BEFORE FABRICATION.

LEGEND :
 X1 — DETAIL MARK NO.
 X001 — REFER SHEET NO.
 1. F.F.L. — FINISHED FLOOR LEVEL
 2. S.F.L. — STRUCTURAL FLOOR LEVEL
 3. (R) — REVERSED DETAIL
 4. GLASS LEGEND
 EGL-1 — 8mmHS+12mm AIR GAP+10mmTP THK. I.G.U.
 EGL-2 — 10mm THK. CLEAR TEMPERED GLASS
 EGL-4 — 10mm THK. TEMPERED ACID ETCHED GLASS
 EGL-1A — 8mmHS+12mm AIR GAP+8mmTP THK. I.G.U.

NO.	DATE	REVISION	BY
H	22/04/2022	REVISION SUBJECT TO ARCH.COMMENT	Ivan
G	08/04/2022	REVISION SUBJECT TO ARCH.COMMENT	Ivan
F	14/12/2021	REVISION SUBJECT TO ARCH.COMMENT	Ivan
E	29/11/2021	REVISION SUBJECT TO ARCH.COMMENT	Ivan
D	02/11/2021	REVISION SUBJECT TO ARCH.COMMENT	Ivan
C	28/10/2021	REVISION SUBJECT TO ARCH.COMMENT	Ivan
B	18/10/2021	REVISION SUBJECT TO ARCH.COMMENT	Ivan
A	27/09/2021	REVISION SUBJECT TO ARCH.COMMENT	Ivan

JOB NO. : J-856
 PROJECT : PROPOSED DEVELOPMENT ABOVE LIGHT RAIL TIN WING STOP, TSWTL NO.23, AREA 33, TIN SHUI WAI, N.T.

TITLE : WINDOW SCHEDULE FOR TOWER 3 ALUM. WINDOW

DATE : 02-Aug-21 SCALE : 1:40
 DRAWN BY : Ivan CHECKED BY :

美特鋁質有限公司
 MIDI ALUMINIUM FABRICATOR LTD.
 Units 6-8, Sunray Industrial Centre, 1/F
 610 Cha Kwo Ling Road, Kowloon
 Tel:23489211-4 Fax:(852)2727666

DWG NO. : J856-SD-PW-5304 REV. : H

ELEVATION

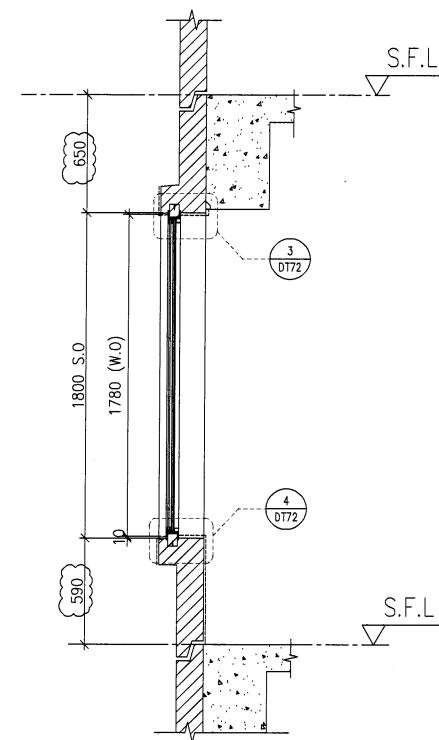
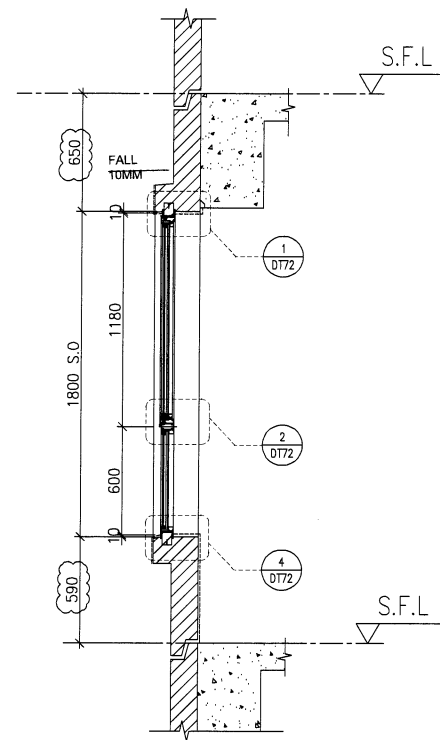
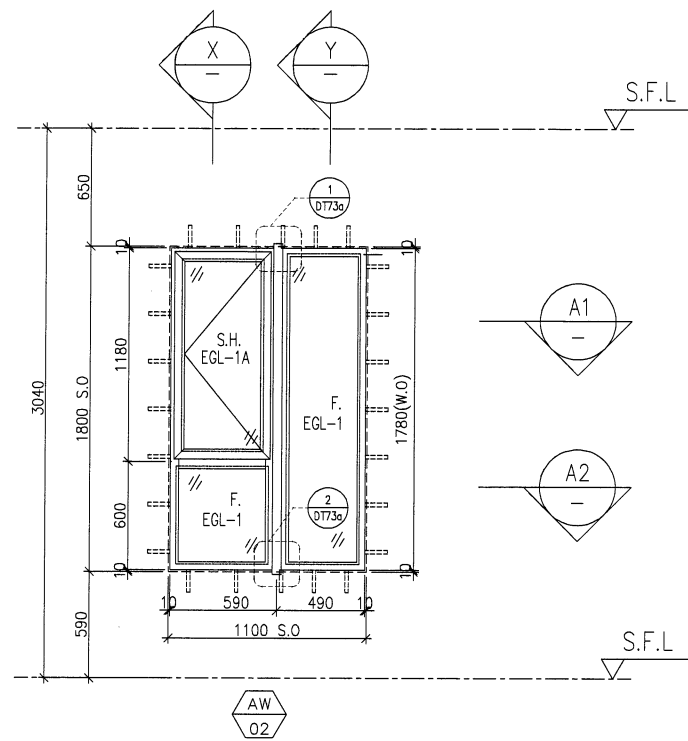

X PART SECTION

Y PART SECTION

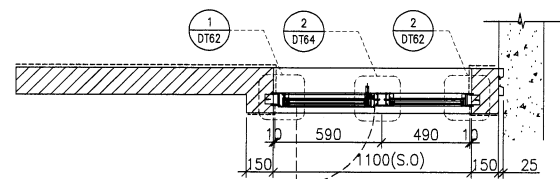

A1 PART PLAN

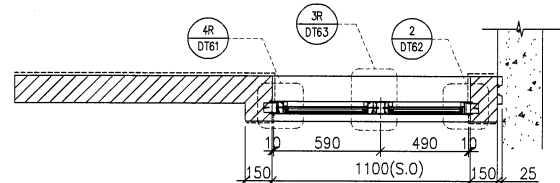

A2 PART PLAN

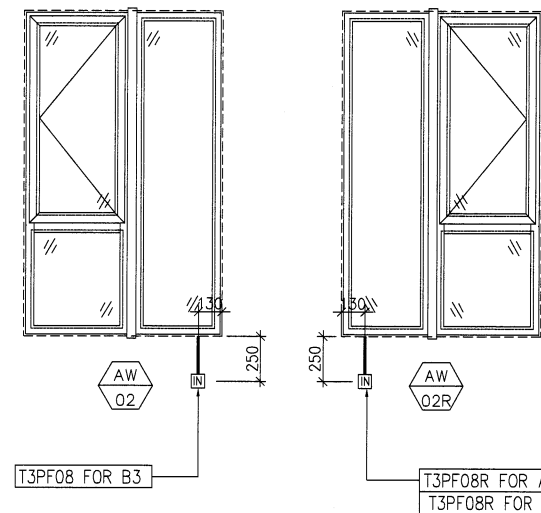

FACADE CODE		
LWK	鴻輝	UNIT
PF-08	T3PF-25	B3
PF-08R	T3PF-10	A5
PF-08R	T3PF-20	B1

WINDOW MARK	AW 02	AW 02R
LOCATION	3/F-42/F(4/F,13/F,14/F,24/F,34/F OMITTED) UNIT B6 & 5/F-42/F FOR (B3)	3/F-42/F(4/F,13/F,14/F,24/F,34/F OMITTED) UNIT (A5, B1)
SECTION	70mm ALUM. SECTION	70mm ALUM. SECTION
GLAZING	EGL-1,EGL-1A	EGL-1,EGL-1A
QUANTITY	35 Nos	35 Nos / 35 Nos
REMARKS	FACADE(TYPE T3PF08) FOR 3/F~42/F	FACADE(TYPE T3PF08R) FOR 3/F~42/F

WINDOW MARK	AW 02	AW 02R
LOCATION	3/F-42/F(4/F,13/F,14/F,24/F,34/F OMITTED) UNIT B6 & 5/F-42/F FOR (B3)	3/F-42/F(4/F,13/F,14/F,24/F,34/F OMITTED) UNIT (A5, B1)
SECTION	70mm ALUM. SECTION	70mm ALUM. SECTION
GLAZING	EGL-1,EGL-1A	EGL-1,EGL-1A
QUANTITY	35 Nos	35 Nos / 35 Nos
REMARKS	FACADE(TYPE T3PF08) FOR 3/F~42/F	FACADE(TYPE T3PF08R) FOR 3/F~42/F

B.D. REF :

CLIENT :
SUN HUNG KAI
 REAL ESTATE AGENCY LTD.
 42/F SUN HUNG KAI CENTRE, WANCHAI, HONGKONG

ARCHITECT :
IWK&partners
 architects

MAIN CONTRACTOR :
怡輝建築有限公司
 Yee Fai Building Contractors Ltd.

STRUCTURAL ENGINEER :
ARUP

FACADE CONSULTANT:
ALPHA CONSULTING LIMITED
 Steel Structure & Facade Specialist

NOTE :
 1. ALL DIMENSIONS ARE IN mm.
 2. ALL ELEVATIONS ARE VIEWED FROM OUTSIDE.
 3. ALL DIMENSIONS TO BE VERIFIED ON SITE BEFORE FABRICATION.

LEGEND :
 X1 --- DETAIL MARK NO.
 X001 --- REFER SHEET NO.

1. F.F.L. --- FINISHED FLOOR LEVEL
 2. S.F.L. --- STRUCTURAL FLOOR LEVEL
 3. (R) --- REVERSED DETAIL
 4. GLASS LEGEND
 EGL-1--8mmHS+12mm AIR GAP+10mmTP THK. I.G.U.
 EGL-2--10mm THK. CLEAR TEMPERED GLASS
 EGL-4--10mm THK. TEMPERED ACID ETCHED GLASS
 EGL-1A-8mmHS+12mm AIR GAP+8mmTP THK. I.G.U.

H	22/04/2022	REVISION SUBJECT TO ARCH.COMMENT	Ivan
G	08/04/2022	REVISION SUBJECT TO ARCH.COMMENT	Ivan
F	14/12/2021	REVISION SUBJECT TO ARCH.COMMENT	Ivan
E	29/11/2021	REVISION SUBJECT TO ARCH.COMMENT	Ivan
D	02/11/2021	REVISION SUBJECT TO ARCH.COMMENT	Ivan
C	28/10/2021	REVISION SUBJECT TO ARCH.COMMENT	Ivan
B	18/10/2021	REVISION SUBJECT TO ARCH.COMMENT	Ivan
A	27/09/2021	REVISION SUBJECT TO ARCH.COMMENT	Ivan
NO.	DATE	REVISED	BY

JOB NO. : J-856
 PROJECT : PROPOSED DEVELOPMENT ABOVE LIGHT RAIL TIN WING STOP,TSWTL NO.23,AREA 33,TIN SHUI WAI, N.T.

TITLE : WINDOW SCHEDULE FOR TOWER 3 ALUM. WINDOW

DATE : 02-Aug-21 SCALE : 1:40
 DRAWN BY : Ivan CHECKED BY :

美特鋁質有限公司
 MIDI ALUMINIUM FABRICATOR LTD.
 Units 6-8, Sunray Industrial Centre, 1/F
 610 Cha Kwo Ling Road, Kowloon
 Tel:23489211-4 Fax:(852)27727666

DWG NO. : J856-SD-PW-5305 REV. : H

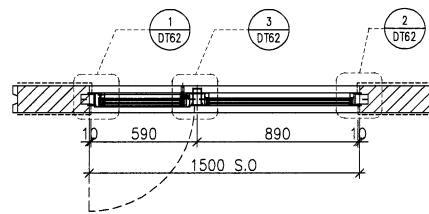
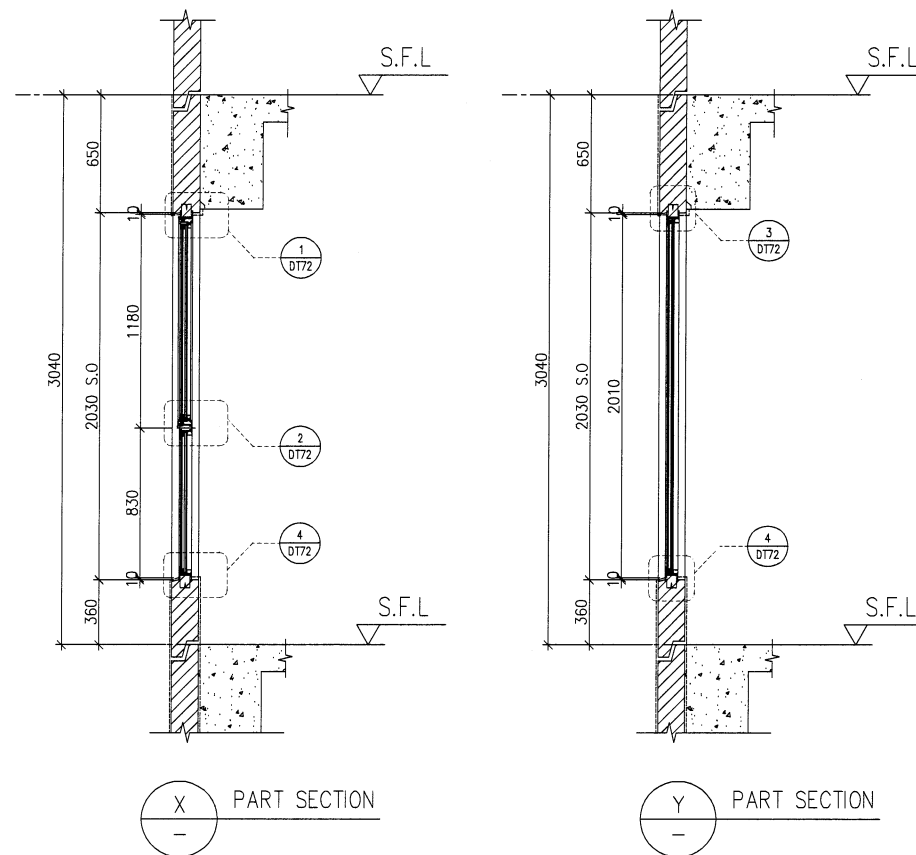
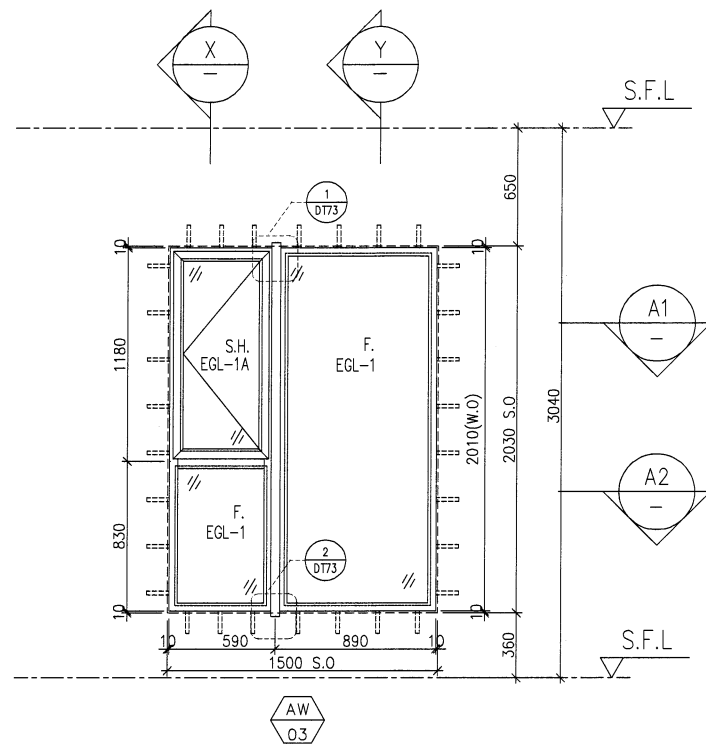

A1 PART PLAN

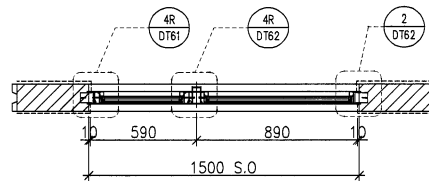

A2 PART PLAN

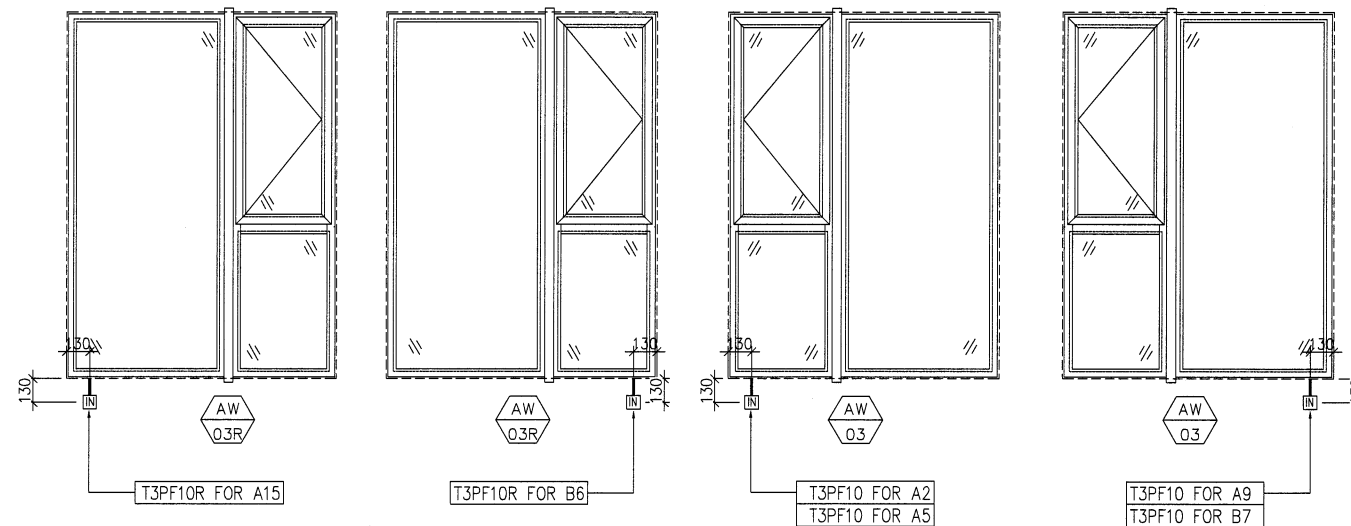

FACADE CODE		
LWK	鴻輝	UNIT
PF-10	T3PF-06	A2
PF-10	T3PF-11	A5
PF-10	T3PF-38	A9
PF-10	T3PF-31	B7

FACADE CODE		
LWK	鴻輝	UNIT
PF-10R	T3PF-45	A15
PF-10R	T3PF-29	B6

ELEVATION

B.D. REF :

CLIENT :
SUN HUNG KAI
 REAL ESTATE AGENCY LTD.
 42/F SUN HUNG KAI CENTRE, WANCHAI, HONGKONG

ARCHITECT :
lwk&partners
 architects

MAIN CONTRACTOR :
怡輝建築有限公司
Yee Fai Building Contractors Ltd.

STRUCTURAL ENGINEER :
ARUP

FACADE CONSULTANT :
ALPHA CONSULTING LIMITED
 Steel Structure & Facade Specialist

NOTE :
 1. ALL DIMENSIONS ARE IN mm.
 2. ALL ELEVATIONS ARE VIEWED FROM OUTSIDE.
 3. ALL DIMENSIONS TO BE VERIFIED ON SITE BEFORE FABRICATION.

LEGEND :
 (X1) — DETAIL MARK NO.
 (X001) — REFER SHEET NO.
 1. F.F.L. — FINISHED FLOOR LEVEL
 2. S.F.L. — STRUCTURAL FLOOR LEVEL
 3. (R) — REVERSED DETAIL
 4. GLASS LEGEND
 EGL-1 — 8mmHS+12mm AIR GAP+10mmTP THK. I.G.U.
 EGL-2 — 10mm THK. CLEAR TEMPERED GLASS
 EGL-4 — 10mm THK. TEMPERED ACID ETCHED GLASS
 EGL-1A — 8mmHS+12mm AIR GAP+8mmTP THK. I.G.U.

NO.	DATE	REVISED	BY
G	22/04/2022	REVISION SUBJECT TO ARCH.COMMENT	ivan
F	08/04/2022	REVISION SUBJECT TO ARCH.COMMENT	ivan
E	14/12/2021	REVISION SUBJECT TO ARCH.COMMENT	ivan
D	29/11/2021	REVISION SUBJECT TO ARCH.COMMENT	ivan
C	02/11/2021	REVISION SUBJECT TO ARCH.COMMENT	ivan
B	28/10/2021	REVISION SUBJECT TO ARCH.COMMENT	ivan
A	27/09/2021	REVISION SUBJECT TO ARCH.COMMENT	ivan

JOB NO. : J-856
 PROJECT : PROPOSED DEVELOPMENT ABOVE LIGHT RAIL TIN WING STOP, TSWTL NO.23, AREA 33, TIN SHUI WAI, N.T.

TITLE : WINDOW SCHEDULE FOR TOWER 3 ALUM. WINDOW

DATE : 02-Aug-21 SCALE : 1:40
 DRAWN BY : Ivan CHECKED BY :

美特鋁質有限公司
MIDI ALUMINIUM FABRICATOR LTD.
 Units 6-8, Sunray Industrial Centre, 1/F
 610 Cha Kwo Ling Road, Kowloon
 Tel: 23489211-4 Fax: (852) 27727666
 DWG NO. : J856-SD-PW-5306 REV. : G

WINDOW MARK	LOCATION	SECTION	GLAZING	QUANTITY	REMARKS
AW 03	3/F-42/F(4/F,13/F,14/F,24/F,34/F OMITTED) UNIT {A2, A5, A9, B7}	70mm ALUM. SECTION	EGL-1, EGL-1A	35 Nos / 35 Nos / 35 Nos / 35 Nos	FACADE(TYPE T3PF10) FOR 3/F~42/F
AW 03R	3/F-42/F(4/F,13/F,14/F,24/F,34/F OMITTED) UNIT {A15, B6}	70mm ALUM. SECTION	EGL-1, EGL-1A	35 Nos / 35 Nos	FACADE(TYPE T3PF10R) FOR 3/F~42/F

ELEVATION

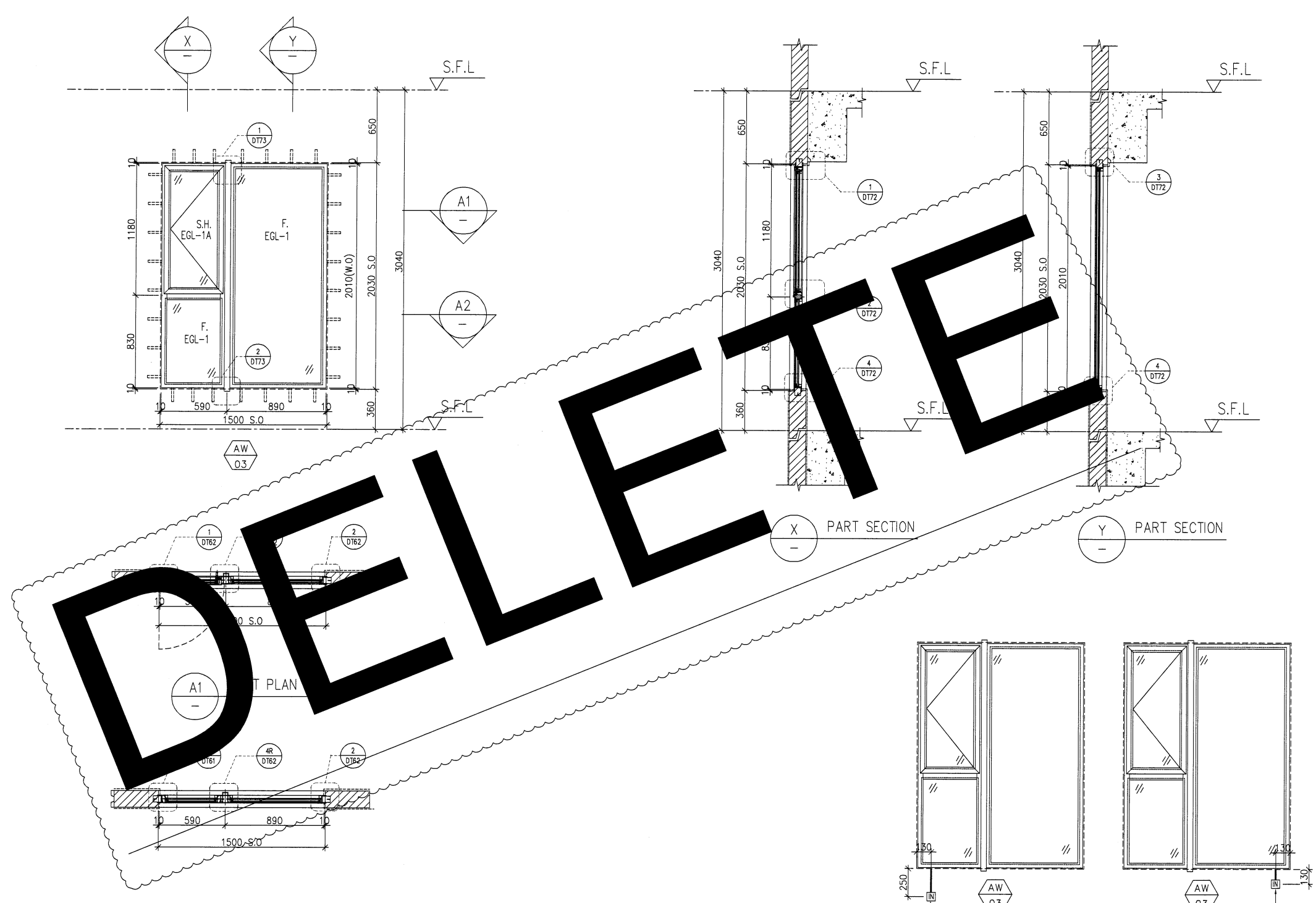

FACADE CODE		
LWK	鴻輝	UNIT
PF-11	T3PF-03	A1
PF-11	T3PF-17	B10

CHANGE TO IN-SITU WINDOWS?
CHANGE TO IN-SITU WINDOWS?

WINDOW MARK	AW 03
LOCATION	3/F-42/F(4/F,13/F,14/F,24/F,34/F OMITTED) UNIT {A1, B10}
SECTION	70mm ALUM. SECTION
GLAZING	EGL-1,EGL-1A
QUANTITY	35 Nos / 35 Nos
REMARKS	FACADE(TYPE T3PF11) FOR 3/F~42/F)

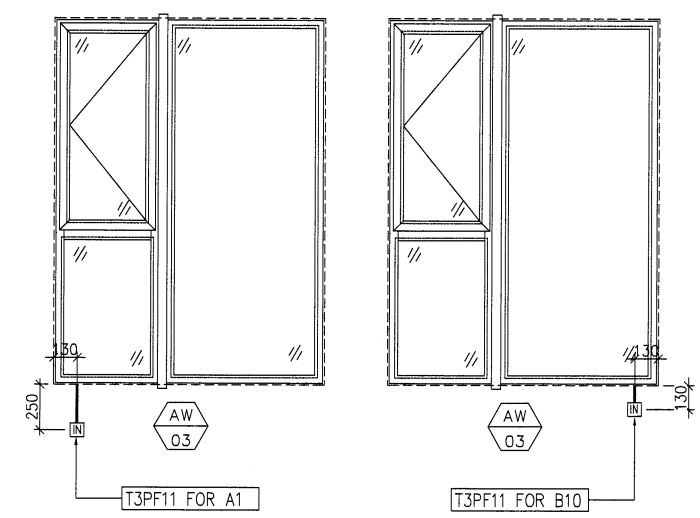

B.D. REF :

CLIENT :
SUN HUNG KAI
REAL ESTATE AGENCY LTD.
42/F SUN HUNG KAI CENTRE, WANCHAI, HONGKONG

ARCHITECT :
lwk&partners
architects

MAIN CONTRACTOR :
Yee Fai Building Contractors Ltd.

STRUCTURAL ENGINEER :
ARUP

FACADE CONSULTANT:
ALPHA CONSULTING LIMITED
Steel Structure & Facade Specialist

NOTE :
1. ALL DIMENSIONS ARE IN mm.
2. ALL ELEVATIONS ARE VIEWED FROM OUTSIDE.
3. ALL DIMENSIONS TO BE VERIFIED ON SITE BEFORE FABRICATION.

LEGEND :
X1 - DETAIL MARK NO.
X001 - REFER SHEET NO.
1. F.F.L. -- FINISHED FLOOR LEVEL
2. S.F.L. -- STRUCTURAL FLOOR LEVEL
3. (R) -- REVERSED DETAIL
4. GLASS LEGEND
EGL-1--8mmHS+12mm AIR GAP+10mmTP THK. I.G.U.
EGL-2--10mm THK. CLEAR TEMPERED GLASS
EGL-4--10mm THK. TEMPERED ACID ETCHED GLASS
EGL-1A--8mmHS+12mm AIR GAP+8mmTP THK. I.G.U.

NO.	DATE	REVISED	BY
H	18/05/2022	REVISION SUBJECT TO ARCH.COMMENT	Ivan
G	22/04/2022	REVISION SUBJECT TO ARCH.COMMENT	Ivan
F	08/04/2022	REVISION SUBJECT TO ARCH.COMMENT	Ivan
E	14/12/2021	REVISION SUBJECT TO ARCH.COMMENT	Ivan
D	29/11/2021	REVISION SUBJECT TO ARCH.COMMENT	Ivan
C	02/11/2021	REVISION SUBJECT TO ARCH.COMMENT	Ivan
B	28/10/2021	REVISION SUBJECT TO ARCH.COMMENT	Ivan
A	27/09/2021	REVISION SUBJECT TO ARCH.COMMENT	Ivan

JOB NO. : J-856
PROJECT : PROPOSED DEVELOPMENT ABOVE LIGHT RAIL TIN WING STOP, TSWTL NO.23, AREA 33, TIN SHUI WAI, N.T.

TITLE : WINDOW SCHEDULE FOR TOWER 3 ALUM. WINDOW

DATE : 02-Aug-21 SCALE : 1:40
DRAWN BY : Ivan CHECKED BY :

美特鋁質有限公司
MIDI ALUMINIUM FABRICATOR LTD.
Units 6-8, Sunray Industrial Centre, 1/F
610 Cha Kwo Ling Road, Kowloon
Tel:23489211-4 Fax:(852)27727666

DWG NO. : J856-SD-PW-5307 REV. : H

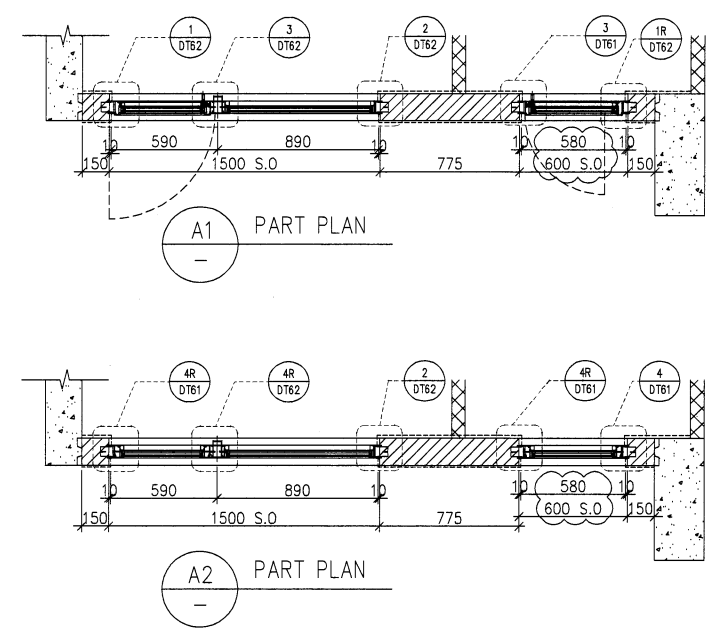
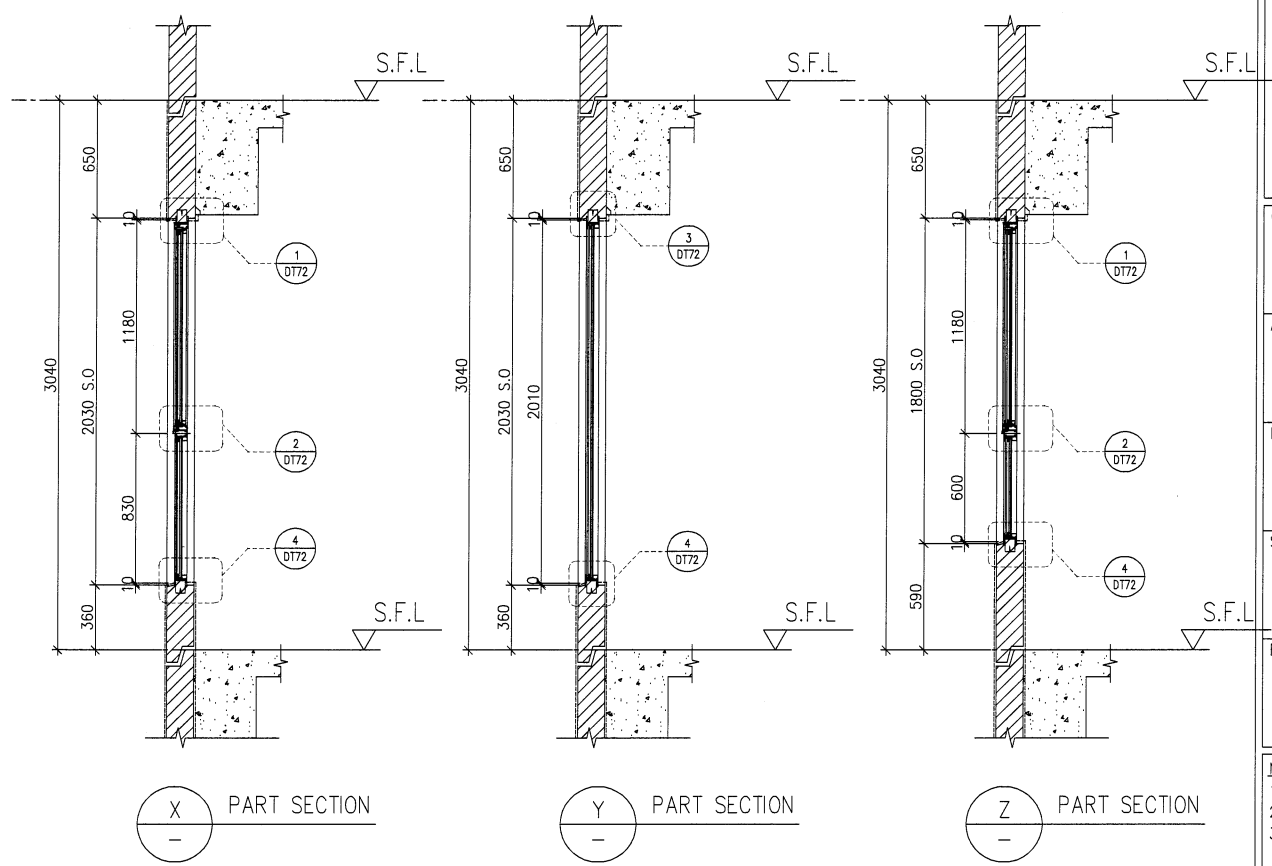
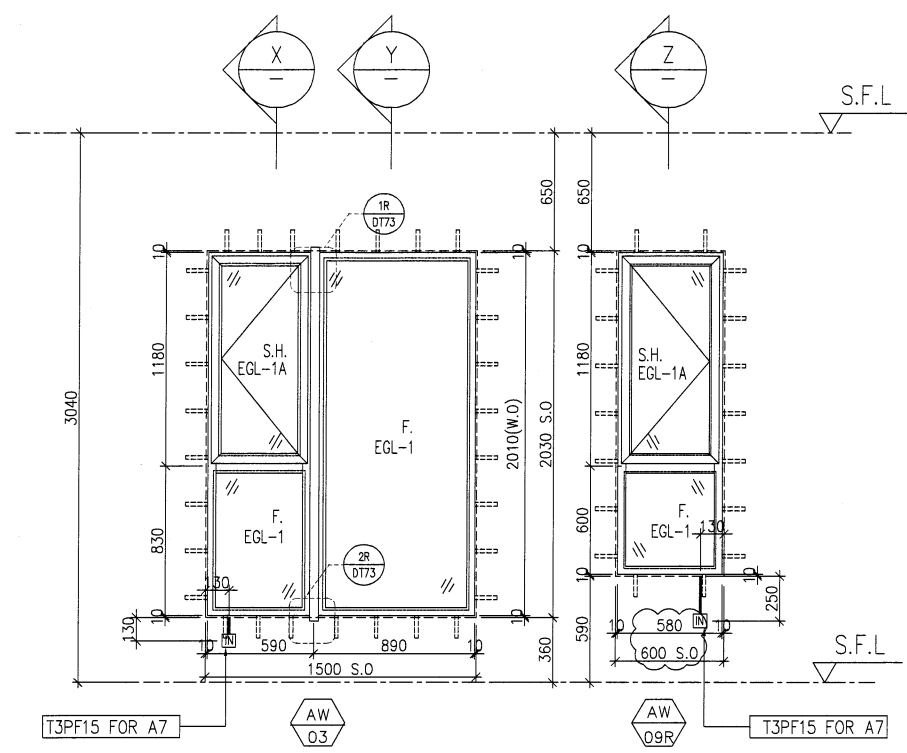

ELEVATION

FACADE CODE		
LWK	鴻輝	UNIT
PF-15	T3PF-14	A7

WINDOW MARK	AW O3R	AW O9R
LOCATION	3/F-42/F(4/F,13/F,14/F,24/F,34/F OMITTED) UNIT(A7)	
SECTION	70mm ALUM. SECTION	
GLAZING	EGL-1,EGL-1A	
QUANTITY	35 Nos	
REMARKS	FACADE(TYPE T3PF15 FOR 3/F~42/F)	

B.D. REF :

CLIENT :
 SUN HUNG KAI REAL ESTATE AGENCY LTD.
 42/F SUN HUNG KAI CENTRE, WANCHAI, HONGKONG

ARCHITECT :
lwk&partners
 architects

MAIN CONTRACTOR :
 怡輝建築有限公司
 Yee Fai Building Contractors Ltd.

STRUCTURAL ENGINEER :
ARUP

FACADE CONSULTANT:
 ALPHA CONSULTING LIMITED
 Steel Structure & Facade Specialist

NOTE :
 1. ALL DIMENSIONS ARE IN mm.
 2. ALL ELEVATIONS ARE VIEWED FROM OUTSIDE.
 3. ALL DIMENSIONS TO BE VERIFIED ON SITE BEFORE FABRICATION.

LEGEND :
 X1 — DETAIL MARK NO.
 X001 — REFER SHEET NO.

1. F.F.L. --- FINISHED FLOOR LEVEL
 2. S.F.L. --- STRUCTURAL FLOOR LEVEL
 3. (R) --- REVERSED DETAIL
 4. GLASS LEGEND
 EGL-1--8mmHS+12mm AIR GAP+10mmTP THK. I.G.U.
 EGL-2--10mm THK. CLEAR TEMPERED GLASS
 EGL-4--10mm THK. TEMPERED ACID ETCHED GLASS
 EGL-1A--8mmHS+12mm AIR GAP+8mmTP THK. I.G.U.

NO.	DATE	REVISION	BY
I	17/05/2022	REVISION SUBJECT TO ARCH.COMMENT	Ivan
H	22/04/2022	REVISION SUBJECT TO ARCH.COMMENT	Ivan
G	08/04/2022	REVISION SUBJECT TO ARCH.COMMENT	Ivan
F	14/12/2021	REVISION SUBJECT TO ARCH.COMMENT	Ivan
E	29/11/2021	REVISION SUBJECT TO ARCH.COMMENT	Ivan
D	02/11/2021	REVISION SUBJECT TO ARCH.COMMENT	Ivan
C	28/10/2021	REVISION SUBJECT TO ARCH.COMMENT	Ivan
B	18/10/2021	REVISION SUBJECT TO ARCH.COMMENT	Ivan
A	27/09/2021	REVISION SUBJECT TO ARCH.COMMENT	Ivan

JOB NO. : J-856

PROJECT :
 PROPOSED DEVELOPMENT ABOVE
 LIGHT RAIL TIN WING STOP,TSWTL
 NO.23,AREA 33,TIN SHUI WAI, N.T.

TITLE :
 WINDOW SCHEDULE FOR
 TOWER 3 ALUM. WINDOW

DATE : 02-Aug-21 SCALE : 1:40
 DRAWN BY : Ivan CHECKED BY :

美特鋁質有限公司
 MIDI ALUMINIUM FABRICATOR LTD.
 Units 6-8, Sunray Industrial Centre, 1/F
 610 Cha Kwo Ling Road, Kowloon
 Tel:23489211-4 Fax:(852)27727666

DWG NO. : J856-SD-PW-5308 REV. : 1

ELEVATION

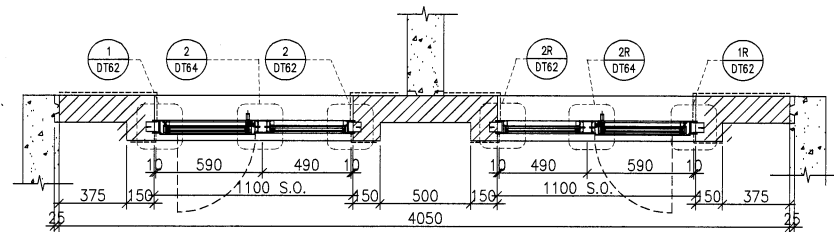
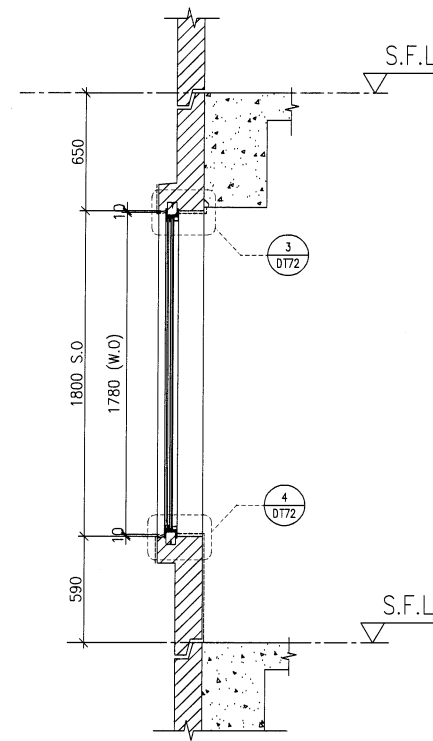
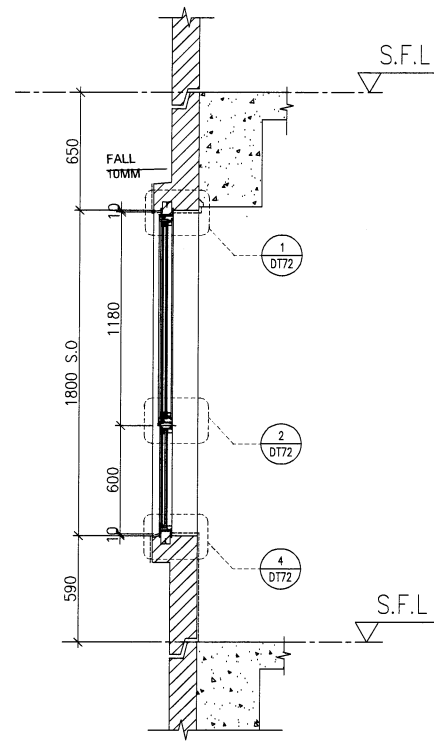
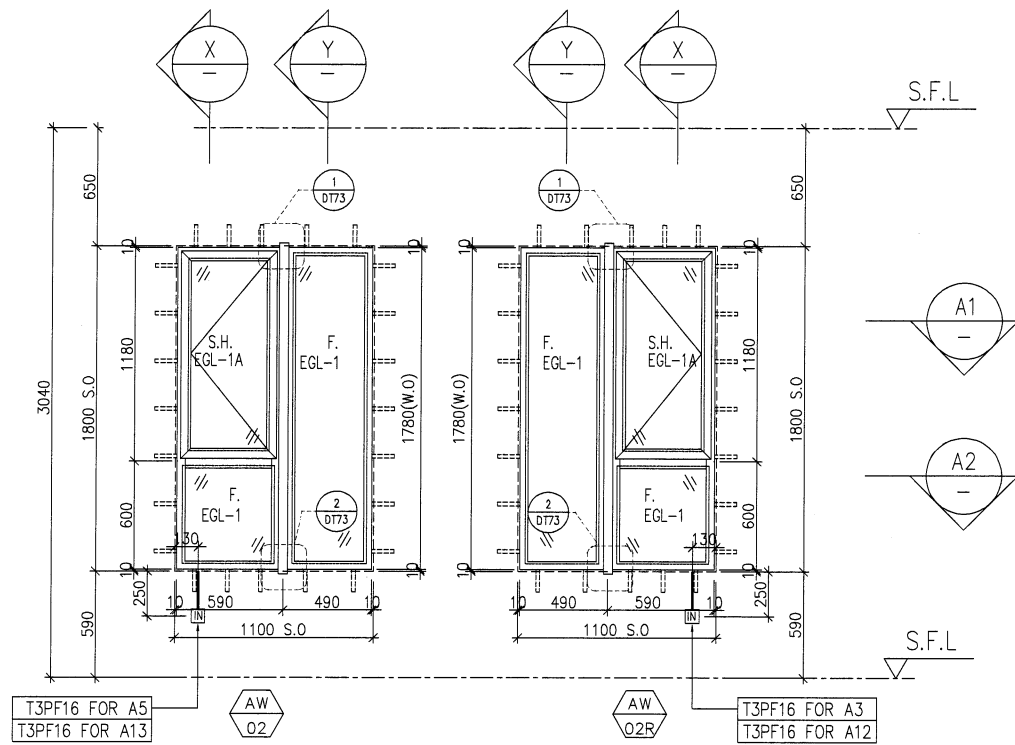

A1 PART PLAN

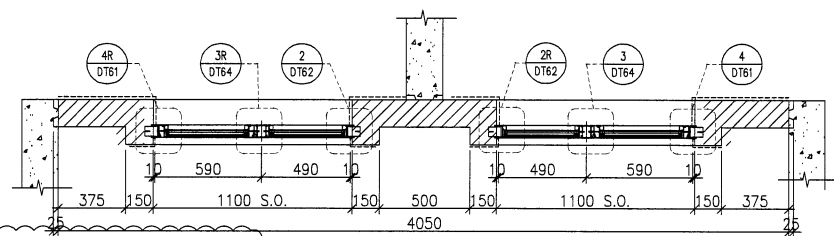

A2 PART PLAN

FACADE CODE		
LWK	鴻輝	UNIT
PF-16	T3PF-09	A3
PF-16	T3PF-09	A5
PF-16	T3PF-43	A13
PF-16	T3PF-43	A12

WINDOW MARK
AW Q2 AW Q2R

LOCATION	5/F-42/F(4/F,13/F,14/F,24/F,34/F OMITTED) UNIT (A5&A3, A13&A12)
SECTION	70mm ALUM. SECTION
GLAZING	EGL-1,EGL-1A
QUANTITY	{34 Nos } 34 Nos
REMARKS	FACADE(TYPE T3PF16 FOR 3/F~42/F)

B.D. REF :

CLIENT :
SUN HUNG KAI
REAL ESTATE AGENCY LTD.
42/F SUN HUNG KAI CENTRE, WANCHAI, HONGKONG

ARCHITECT :
lwk&partners
architects

MAIN CONTRACTOR :
Yee Fai 怡輝建築有限公司
Building Contractors Ltd.

STRUCTURAL ENGINEER :
ARUP

FACADE CONSULTANT:
ALPHA CONSULTING LIMITED
Steel Structure & Facade Specialist

NOTE :
1. ALL DIMENSIONS ARE IN mm.
2. ALL ELEVATIONS ARE VIEWED FROM OUTSIDE.
3. ALL DIMENSIONS TO BE VERIFIED ON SITE BEFORE FABRICATION.

LEGEND :
X1 - DETAIL MARK NO.
X001 - REFER SHEET NO.

1. F.F.L. --- FINISHED FLOOR LEVEL
2. S.F.L. --- STRUCTURAL FLOOR LEVEL
3. (R) --- REVERSED DETAIL
4. GLASS LEGEND
EGL-1--8mmHS+12mm AIR GAP+10mmTP THK. I.G.U.
EGL-2--10mm THK. CLEAR TEMPERED GLASS
EGL-4--10mm THK. TEMPERED ACID ETCHED GLASS
EGL-1A--8mmHS+12mm AIR GAP+8mmTP THK. I.G.U.

NO.	DATE	REVISION	BY
H	22/04/2022	REVISION SUBJECT TO ARCH.COMMENT	ivan
G	08/04/2022	REVISION SUBJECT TO ARCH.COMMENT	ivan
F	14/12/2021	REVISION SUBJECT TO ARCH.COMMENT	ivan
E	29/11/2021	REVISION SUBJECT TO ARCH.COMMENT	ivan
D	02/11/2021	REVISION SUBJECT TO ARCH.COMMENT	ivan
C	28/10/2021	REVISION SUBJECT TO ARCH.COMMENT	ivan
B	18/10/2021	REVISION SUBJECT TO ARCH.COMMENT	ivan
A	27/09/2021	REVISION SUBJECT TO ARCH.COMMENT	ivan

JOB NO. : J-856
PROJECT : PROPOSED DEVELOPMENT ABOVE LIGHT RAIL TIN WING STOP, TSWTL NO.23, AREA 33, TIN SHUI WAI, N.T.

TITLE : WINDOW SCHEDULE FOR TOWER 3 ALUM. WINDOW

DATE : 02-Aug-21 SCALE : 1:40
DRAWN BY : Ivan CHECKED BY :

美特鋁質有限公司
MIDI ALUMINIUM FABRICATOR LTD.
Units 6-8, Sunray Industrial Centre, 1/F
610 Cho Kwo Ling Road, Kowloon
Tel:23489211-4 Fax:(852)27727666
DWG NO. : J856-SD-PW-5309 REV. : H

ELEVATION

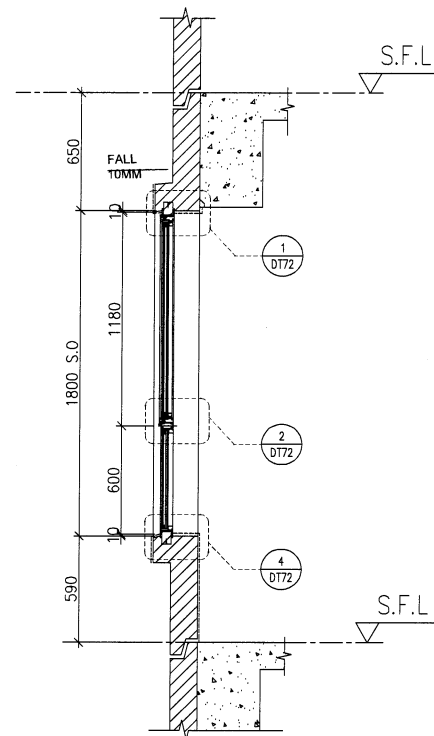
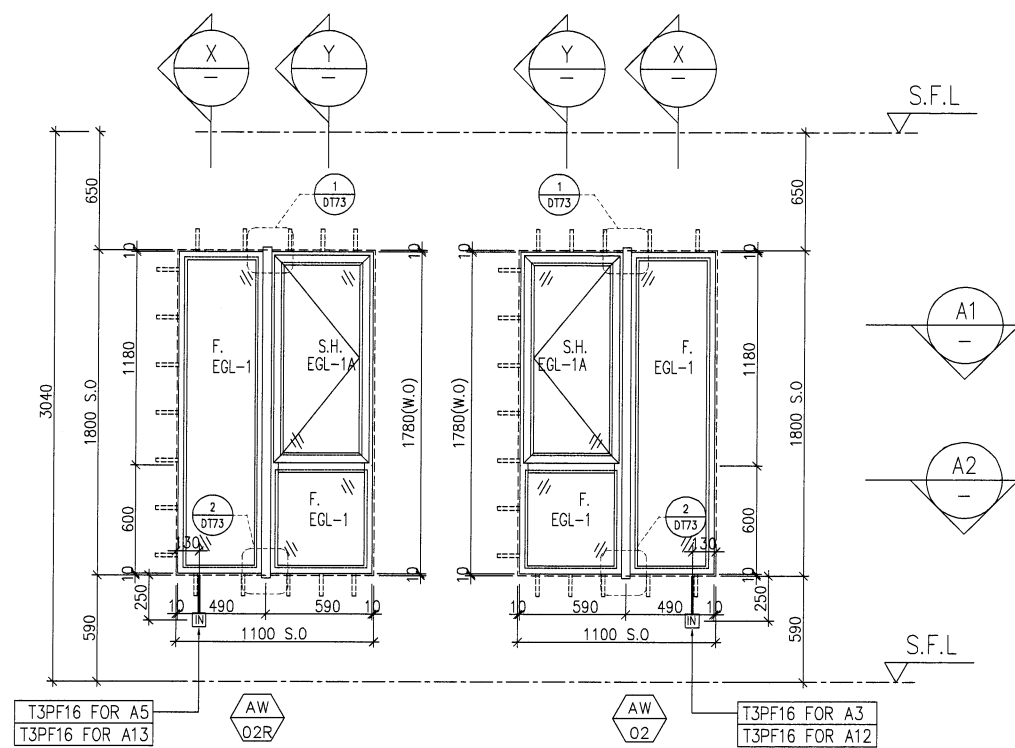

X PART SECTION

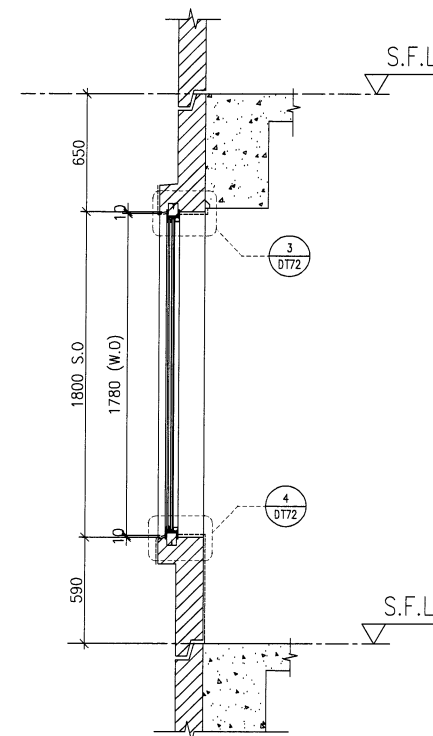

Y PART SECTION

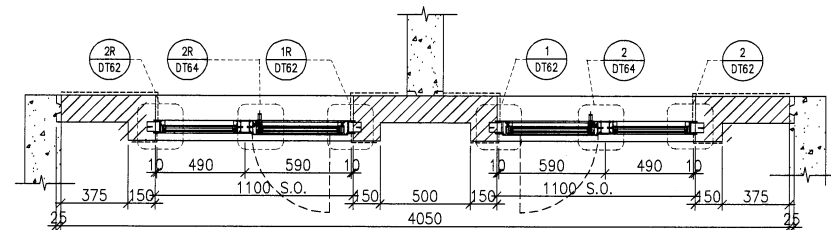

A1 PART PLAN

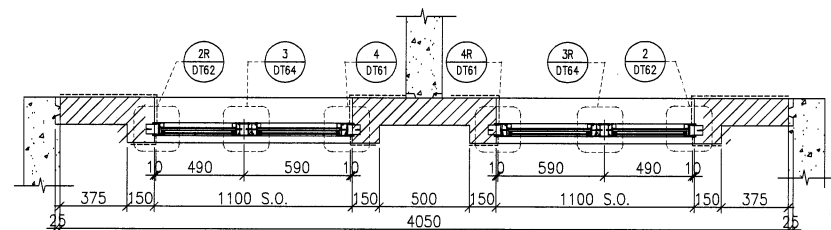

A2 PART PLAN

FACADE CODE		
LWK	鴻輝	UNIT
PF-16	T3PF-09	A3
PF-16	T3PF-09	A5
PF-16	T3PF-43	A13
PF-16	T3PF-43	A12

WINDOW MARK	AW Q2	AW Q2R
-------------	-------	--------

LOCATION	3/F UNIT A5&A3, A13&A12
SECTION	70mm ALUM. SECTION
GLAZING	EGL-1, EGL-1A
QUANTITY	1 No \ 1 No
REMARKS	FACADE(TYPE T3PF16 FOR 3/F~42/F)

B.D. REF :

CLIENT :

SUN HUNG KAI
REAL ESTATE AGENCY LTD.
42/F SUN HUNG KAI CENTRE, WANCHAI, HONGKONG

ARCHITECT :

lwk&partners
architects

MAIN CONTRACTOR :

Yee Fai Building Contractors Ltd.

STRUCTURAL ENGINEER :

ARUP

FACADE CONSULTANT:

ALPHA CONSULTING LIMITED
Steel Structure & Facade Specialist

NOTE :

1. ALL DIMENSIONS ARE IN mm.
2. ALL ELEVATIONS ARE VIEWED FROM OUTSIDE.
3. ALL DIMENSIONS TO BE VERIFIED ON SITE BEFORE FABRICATION.

LEGEND :

- X1 — DETAIL MARK NO.
- X001 — REFER SHEET NO.

1. F.F.L. — FINISHED FLOOR LEVEL
2. S.F.L. — STRUCTURAL FLOOR LEVEL
3. (R) — REVERSED DETAIL
4. GLASS LEGEND

EGL-1—8mmHS+12mm AIR GAP+10mmTP THK. I.G.U.
EGL-2—10mm THK. CLEAR TEMPERED GLASS
EGL-4—10mm THK. TEMPERED ACID ETCHED GLASS
EGL-1A—8mmHS+12mm AIR GAP+8mmTP THK. I.G.U.

NO.	DATE	REVISED	BY
-----	------	---------	----

JOB NO. : J-856

PROJECT :
PROPOSED DEVELOPMENT ABOVE
LIGHT RAIL TIN WING STOP, TSWTL
NO.23, AREA 33, TIN SHUI WAI, N.T.

TITLE :
WINDOW SCHEDULE FOR
TOWER 3 ALUM. WINDOW

DATE : 23-Apr-21 SCALE : 1:40

DRAWN BY : Ivan CHECKED BY :

英特鋁質有限公司
MIDI ALUMINIUM FABRICATOR LTD.
Units 6-8, Sunray Industrial Centre, 1/F
610 Cha Kwo Ling Road, Kowloon
Tel:23489211-4 Fax:(852)2727666

DWG NO. : J856-SD-PW-5309a REV. : -

ELEVATION

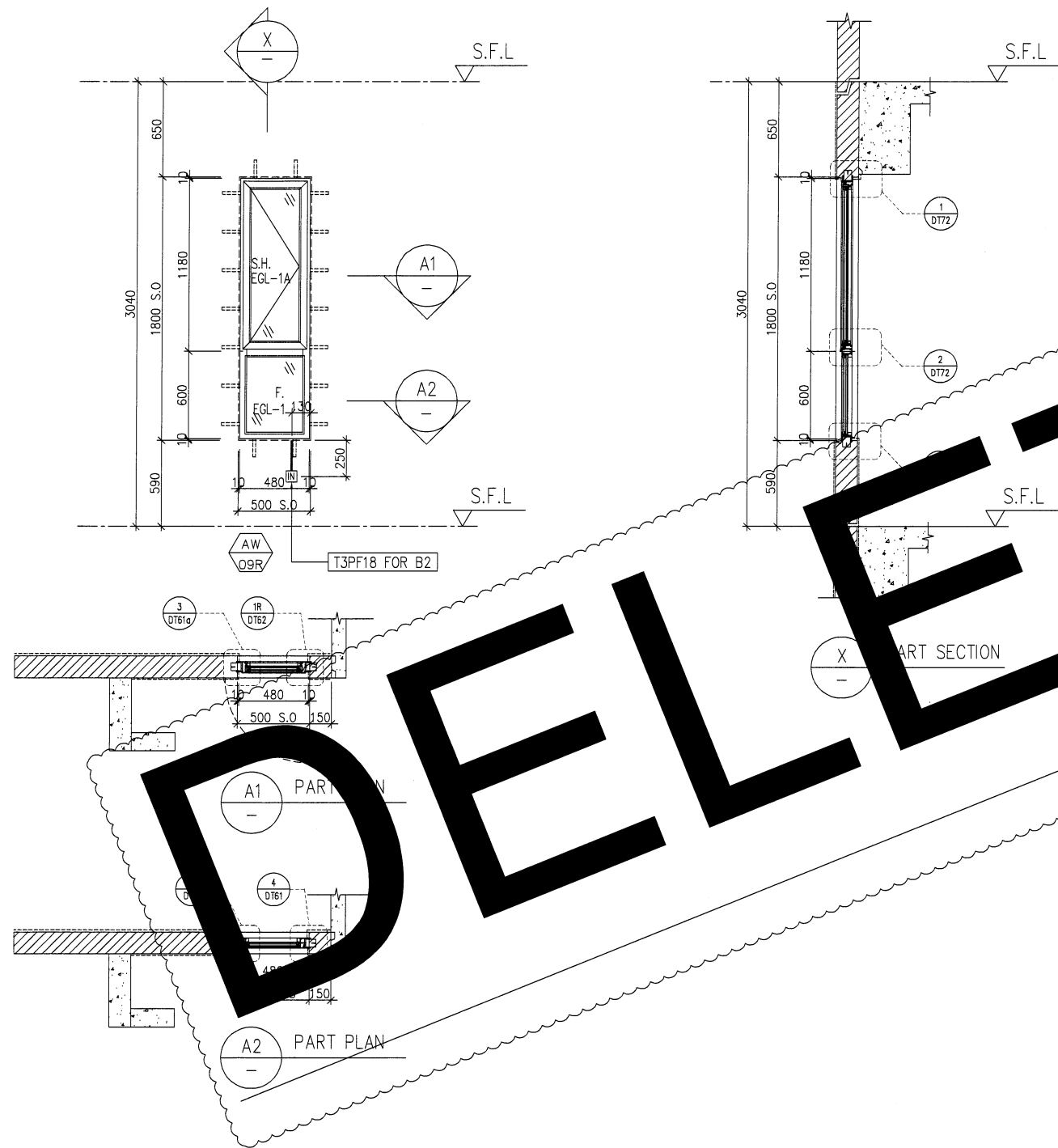

FACADE CODE		
LWK	鴻輝	UNIT
PF-18	T3PF=46	B2

CHANGE TO IN-SITU WINDOWS?

WINDOW MARK	AW 09R
LOCATION	3/F-42/F(4/F,13/F,14/F,24/F,34/F OMITTED) UNIT (B2)
SECTION	70mm ALUM. SECTION
GLAZING	EGL-1,EGL-1A
QUANTITY	35 Nos
REMARKS	FACADE(TYPE T3PF18) FOR 3/F~42/F)

B.D. REF :

CLIENT :
SUN HUNG KAI
 REAL ESTATE AGENCY LTD.
 42/F SUN HUNG KAI CENTRE, WANCHAI, HONGKONG

ARCHITECT :
Iwk&partners
 architects

MAIN CONTRACTOR :
怡輝建築有限公司
Yee Fai Building Contractors Ltd.

STRUCTURAL ENGINEER :
ARUP

FACADE CONSULTANT:
ALPHA CONSULTING LIMITED
 Steel Structure & Facade Specialist

NOTE :
 1. ALL DIMENSIONS ARE IN mm.
 2. ALL ELEVATIONS ARE VIEWED FROM OUTSIDE.
 3. ALL DIMENSIONS TO BE VERIFIED ON SITE BEFORE FABRICATION.

LEGEND :
 X1 --- DETAIL MARK NO.
 X001 --- REFER SHEET NO.

1. F.F.L. --- FINISHED FLOOR LEVEL
 2. S.F.L. --- STRUCTURAL FLOOR LEVEL
 3. (R) --- REVERSED DETAIL
 4. GLASS LEGEND
 EGL-1--8mmHS+12mm AIR GAP+10mmTP THK. I.G.U.
 EGL-2--10mm THK. CLEAR TEMPERED GLASS
 EGL-4--10mm THK. TEMPERED ACID ETCHED GLASS
 EGL-1A--8mmHS+12mm AIR GAP+8mmTP THK. I.G.U.

NO.	DATE	REVISION	BY
I	18/05/2022	REVISION SUBJECT TO ARCH.COMMENT	Ivan
H	22/04/2022	REVISION SUBJECT TO ARCH.COMMENT	Ivan
G	08/04/2022	REVISION SUBJECT TO ARCH.COMMENT	Ivan
F	14/12/2021	REVISION SUBJECT TO ARCH.COMMENT	Ivan
E	29/11/2021	REVISION SUBJECT TO ARCH.COMMENT	Ivan
D	02/11/2021	REVISION SUBJECT TO ARCH.COMMENT	Ivan
C	28/10/2021	REVISION SUBJECT TO ARCH.COMMENT	Ivan
B	18/10/2021	REVISION SUBJECT TO ARCH.COMMENT	Ivan
A	27/09/2021	REVISION SUBJECT TO ARCH.COMMENT	Ivan

JOB NO. : J-856
 PROJECT : PROPOSED DEVELOPMENT ABOVE LIGHT RAIL TIN WING STOP,TSWTL NO.23,AREA 33,TIN SHUI WAI, N.T.

TITLE : WINDOW SCHEDULE FOR TOWER 3 ALUM. WINDOW

DATE : 02-Aug-21 SCALE : 1:40
 DRAWN BY : Ivan CHECKED BY :

美特鋁質有限公司
MIDI ALUMINIUM FABRICATOR LTD.
 Units 6-8, Sunray Industrial Centre, 1/F
 610 Cho Kwo Ling Road, Kowloon
 Tel:23489211-4 Fax:(852)2727666

DWG NO. : J856-SD-PW-5310 REV. : I

ELEVATION

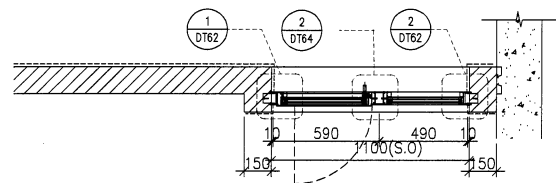
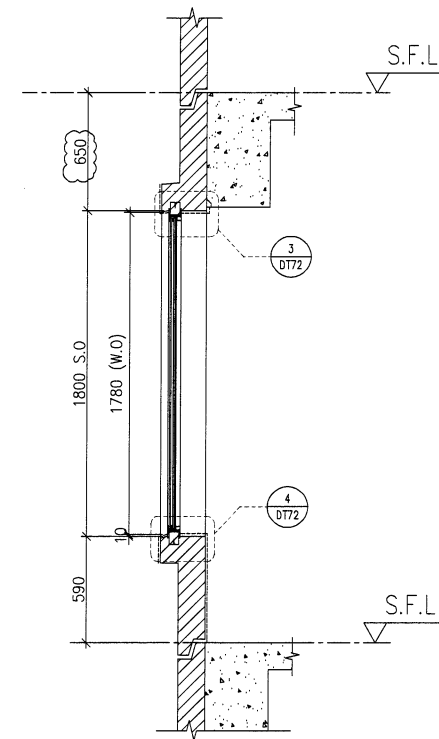
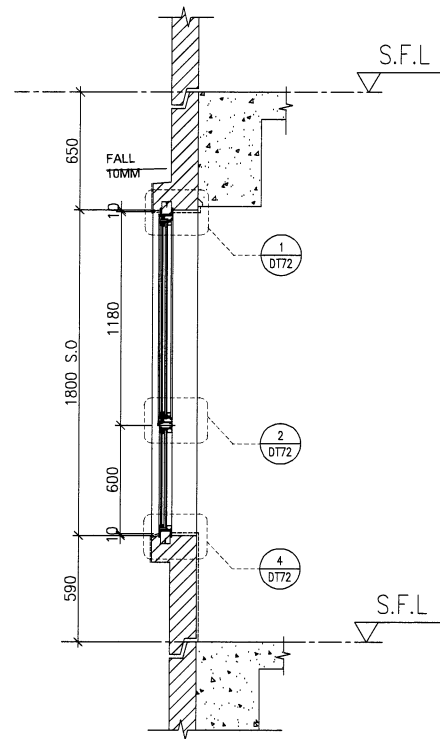
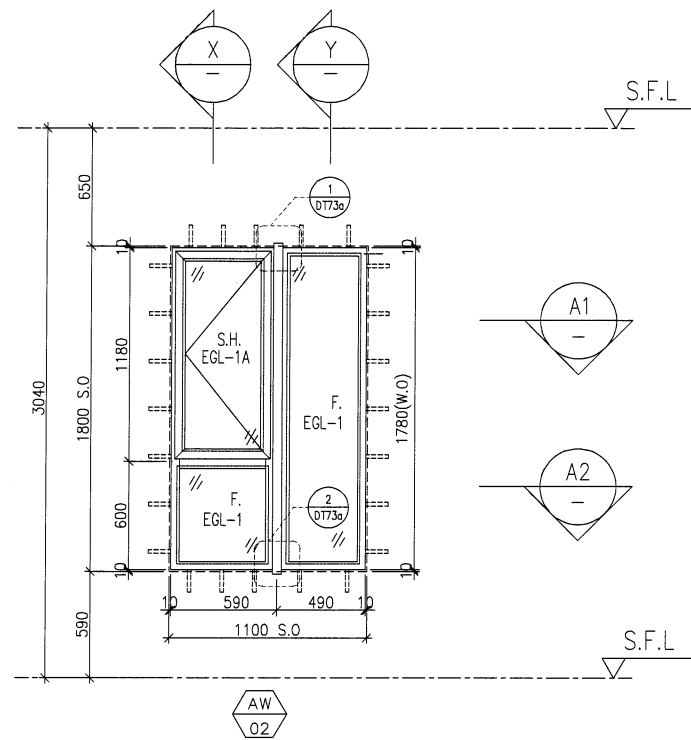

A1 PART PLAN

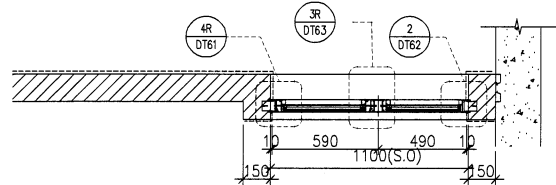

A2 PART PLAN

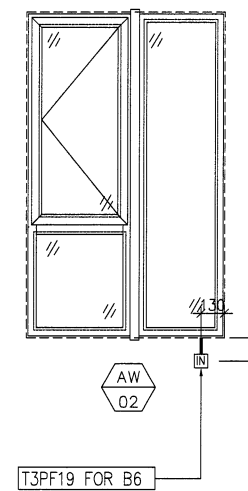

FACADE CODE		
LWK	鴻輝	UNIT
PF-19	T3PF-28	B6

WINDOW MARK	AW 02
LOCATION	3/F-42/F(4/F,13/F,14/F,24/F,34/F OMITTED) UNIT (B6)
SECTION	70mm ALUM. SECTION
GLAZING	EGL-1,EGL-1A
QUANTITY	35 Nos.
REMARKS	FACADE(TYPE T3PF19) FOR 3/F~42/F)

B.D. REF :

CLIENT :
SUN HUNG KAI
 REAL ESTATE AGENCY LTD.
 42/F SUN HUNG KAI CENTRE, WANCHAI, HONGKONG

ARCHITECT :
lwk&partners
 architects

MAIN CONTRACTOR :
怡輝建築有限公司
 Yee Fai Building Contractors Ltd.

STRUCTURAL ENGINEER :
ARUP

FACADE CONSULTANT:
ALPHA CONSULTING LIMITED
 Steel Structure & Facade Specialist

NOTE :
 1. ALL DIMENSIONS ARE IN mm.
 2. ALL ELEVATIONS ARE VIEWED FROM OUTSIDE.
 3. ALL DIMENSIONS TO BE VERIFIED ON SITE BEFORE FABRICATION.

LEGEND :
 X1 — DETAIL MARK NO.
 X001 — REFER SHEET NO.
 1. F.F.L. — FINISHED FLOOR LEVEL
 2. S.F.L. — STRUCTURAL FLOOR LEVEL
 3. (R) — REVERSED DETAIL
 4. GLASS LEGEND
 EGL-1 — 8mmHS+12mm AIR GAP+10mmTP THK. I.G.U.
 EGL-2 — 10mm THK. CLEAR TEMPERED GLASS
 EGL-4 — 10mm THK. TEMPERED ACID ETCHED GLASS
 EGL-1A — 8mmHS+12mm AIR GAP+8mmTP THK. I.G.U.

NO.	DATE	REVISD	BY
E	22/04/2022	REVISION SUBJECT TO ARCH.COMMENT	Ivan
D	08/04/2022	REVISION SUBJECT TO ARCH.COMMENT	Ivan
C	14/12/2021	REVISION SUBJECT TO ARCH.COMMENT	Ivan
B	29/11/2021	REVISION SUBJECT TO ARCH.COMMENT	Ivan
A	18/10/2021	REVISION SUBJECT TO ARCH.COMMENT	Ivan

JOB NO. : J-856
 PROJECT :
 PROPOSED DEVELOPMENT ABOVE
 LIGHT RAIL TIN WING STOP, TSWTL
 NO.23, AREA 33, TIN SHUI WAI, N.T.

TITLE :
 WINDOW SCHEDULE FOR
 TOWER 3 ALUM. WINDOW

DATE : 02-Aug-21 SCALE : 1:40
 DRAWN BY : Ivan CHECKED BY :

英特鋁質有限公司
 MIDI ALUMINIUM FABRICATOR LTD.
 Units 6-8, Sunray Industrial Centre, 1/F
 610 Cha Kwo Ling Road, Kowloon
 Tel:23489211-4 Fax:(852)2727666

DWG NO. : J856-SD-PW-5311 REV. : E

ELEVATION

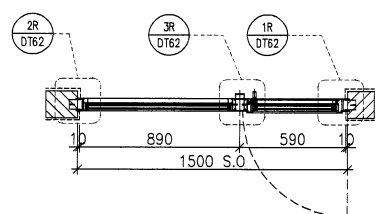
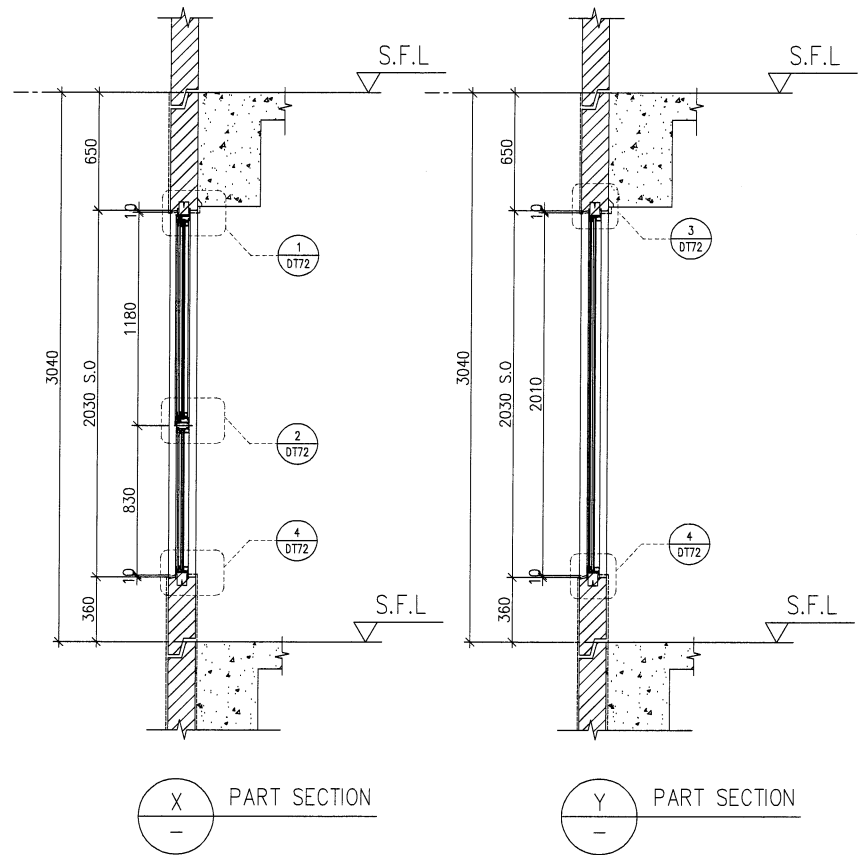
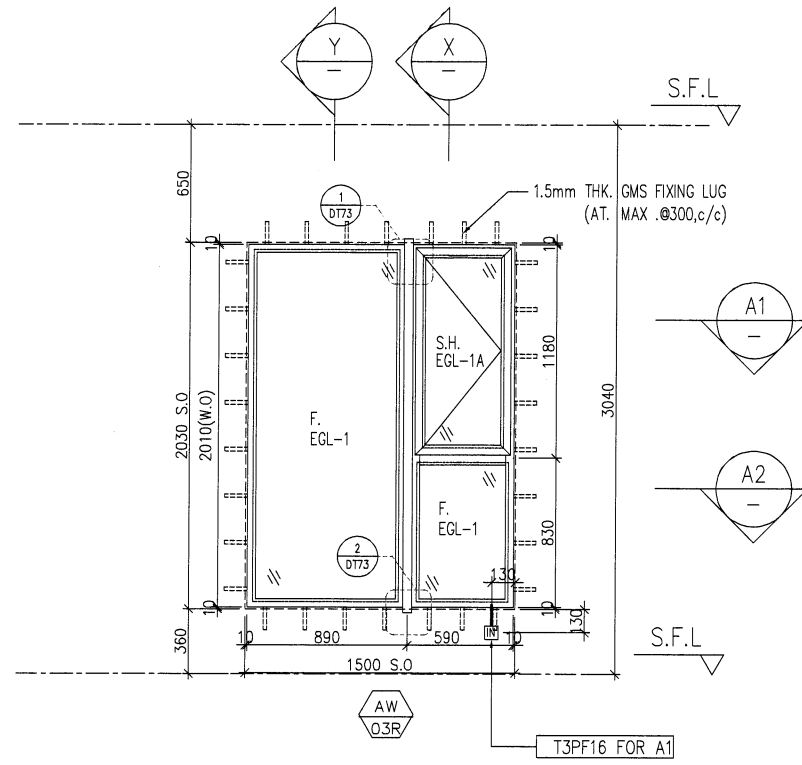

A1 PART PLAN

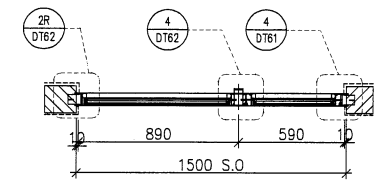

A2 PART PLAN

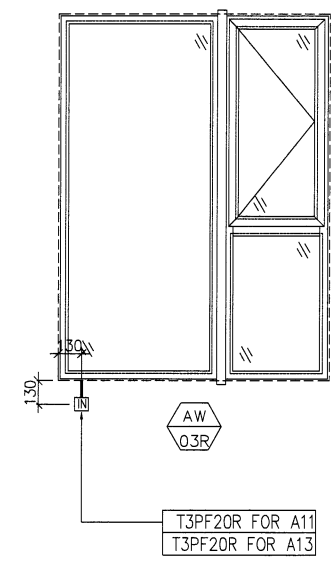

FACADE CODE		
LWK	鴻輝	UNIT
PF-20R	T3PF-41	A11
PF-20R	T3PF-44	A13

WINDOW MARK	AW 03R
LOCATION	3/F-42/F(4/F,13/F,14/F,24/F,34/F OMITTED) UNIT {A11, A13}
SECTION	70mm ALUM. SECTION
GLAZING	EGL-1,EGL-1A
QUANTITY	35 Nos \ 35 Nos
REMARKS	FACADE(TYPE {T3PF20R} FOR 3/F~42/F)

B.D. REF :

CLIENT :
SUN HUNG KAI
 REAL ESTATE AGENCY LTD.
 42/F SUN HUNG KAI CENTRE, WANCHAI, HONGKONG

ARCHITECT :
lwk&partners
 architects

MAIN CONTRACTOR :
Yee Fai Building Contractors Ltd.

STRUCTURAL ENGINEER :
ARUP

FACADE CONSULTANT :
ALPHA CONSULTING LIMITED
 Steel Structure & Facade Specialist

NOTE :
 1. ALL DIMENSIONS ARE IN mm.
 2. ALL ELEVATIONS ARE VIEWED FROM OUTSIDE.
 3. ALL DIMENSIONS TO BE VERIFIED ON SITE BEFORE FABRICATION.

LEGEND :
 X1 — DETAIL MARK NO.
 X001 — REFER SHEET NO.

1. F.F.L. — FINISHED FLOOR LEVEL
 2. S.F.L. — STRUCTURAL FLOOR LEVEL
 3. (R) — REVERSED DETAIL
 4. GLASS LEGEND
 EGL-1 — 8mmHS+12mm AIR GAP+10mmTP THK. I.G.U.
 EGL-2 — 10mm THK. CLEAR TEMPERED GLASS
 EGL-4 — 10mm THK. TEMPERED ACID ETCHED GLASS
 EGL-1A — 8mmHS+12mm AIR GAP+8mmTP THK. I.G.U.

D	22/04/2022	REVISION SUBJECT TO ARCH.COMMENT	Ivan
C	08/04/2022	REVISION SUBJECT TO ARCH.COMMENT	Ivan
B	14/12/2021	REVISION SUBJECT TO ARCH.COMMENT	Ivan
A	18/10/2021	REVISION SUBJECT TO ARCH.COMMENT	Ivan
NO.	DATE	REVISED	BY

JOB NO. : J-856
 PROJECT : PROPOSED DEVELOPMENT ABOVE LIGHT RAIL TIN WING STOP, TSWTL NO.23, AREA 33, TIN SHUI WAI, N.T.

TITLE : WINDOW SCHEDULE FOR TOWER 3 ALUM. WINDOW

DATE : 02-Aug-21 SCALE : 1:40
 DRAWN BY : Ivan CHECKED BY :

英特鋁質有限公司
 MIDI ALUMINIUM FABRICATOR LTD.
 Units 6-8, Sunray Industrial Centre, 1/F
 610 Cha Kwo Ling Road, Kowloon
 Tel:23489211-4 Fax:(852)27727666
 DWG NO. : J856-SD-PW-5312 REV. : D

ELEVATION

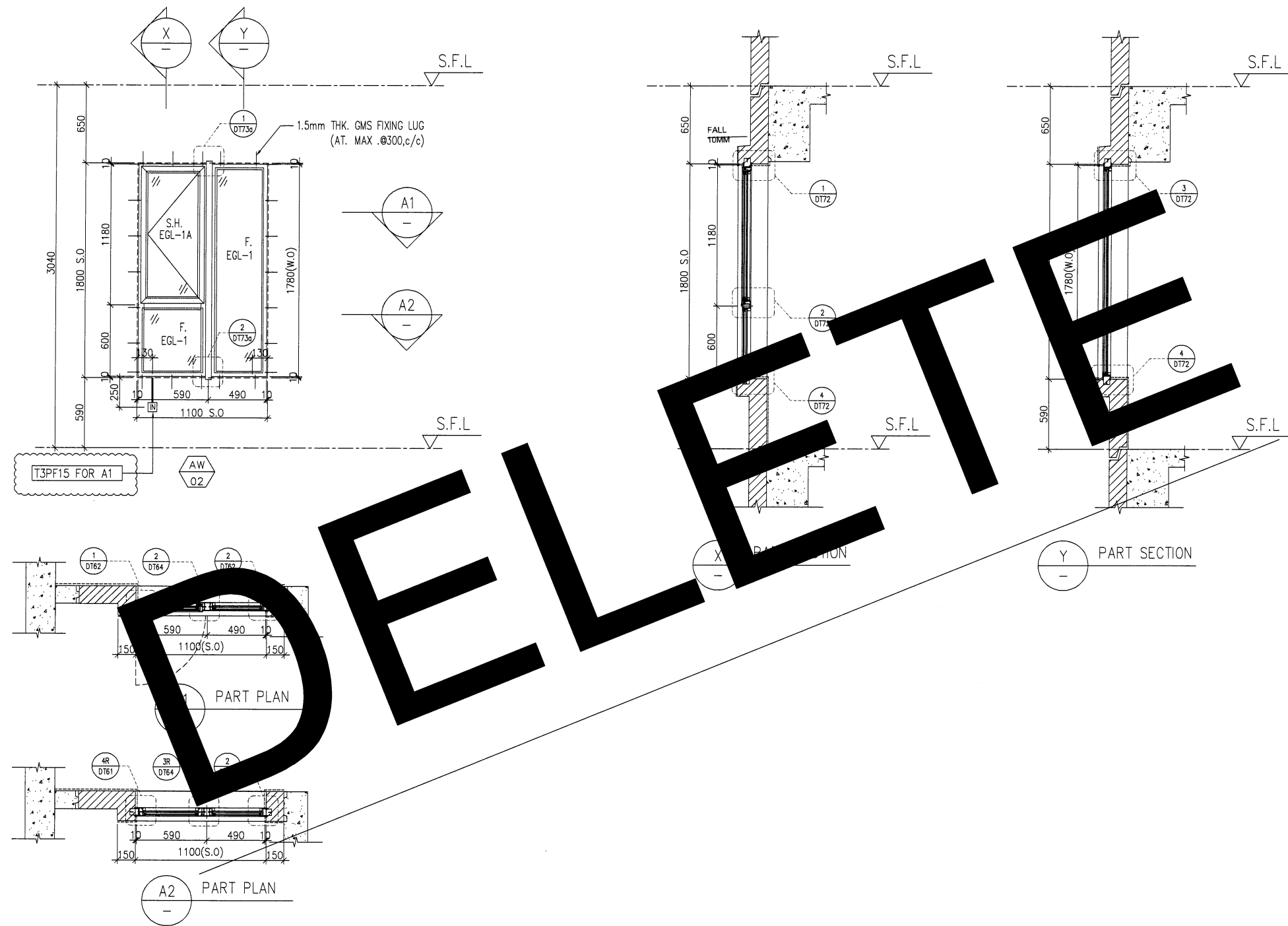

DELETED

B.D. REF :

CLIENT :
SUN HUNG KAI
 REAL ESTATE AGENCY LTD.
 42/F SUN HUNG KAI CENTRE, WANCHAI, HONGKONG

ARCHITECT :
lwk&partners
 architects

MAIN CONTRACTOR :
怡輝建築有限公司
Yee Fai Building Contractors Ltd.

STRUCTURAL ENGINEER :
ARUP

FAÇADE CONSULTANT:
ALPHA CONSULTING LIMITED
 Steel Structure & Façade Specialist

NOTE :
 1. ALL DIMENSIONS ARE IN mm.
 2. ALL ELEVATIONS ARE VIEWED FROM OUTSIDE.
 3. ALL DIMENSIONS TO BE VERIFIED ON SITE BEFORE FABRICATION.

LEGEND :
 (X1) — DETAIL MARK NO.
 (X001) — REFER SHEET NO.
 1. F.F.L. — FINISHED FLOOR LEVEL
 2. S.F.L. — STRUCTURAL FLOOR LEVEL
 3. (R) — REVERSED DETAIL
 4. GLASS LEGEND
 EGL-1 — 8mmHS+12mm AIR GAP+10mmTP THK. I.G.U.
 EGL-2 — 10mm THK. CLEAR TEMPERED GLASS
 EGL-4 — 10mm THK. TEMPERED ACID ETCHED GLASS
 EGL-1A — 8mmHS+12mm AIR GAP+8mmTP THK. I.G.U.

NO.	DATE	REVISED	BY
D	08/04/2022	REVISION SUBJECT TO ARCH.COMMENT	Ivan
C	21/12/2021	REVISION SUBJECT TO ARCH.COMMENT	Ivan
B	18/10/2021	REVISION SUBJECT TO ARCH.COMMENT	Ivan
A	12/10/2021	REVISION SUBJECT TO ARCH.COMMENT	Ivan

JOB NO. : J-856
 PROJECT : PROPOSED DEVELOPMENT ABOVE LIGHT RAIL TIN WING STOP, TSWTL NO.23, AREA 33, TIN SHUI WAI, N.T.

TITLE : WINDOW SCHEDULE FOR TOWER 3 ALUM. WINDOW

DATE : 02-Aug-21 SCALE : 1:40

DRAWN BY : Ivan CHECKED BY :

美特鋁質有限公司
MIDI ALUMINIUM FABRICATOR LTD.
 Units 6-8, Sunray Industrial Centre, 1/F
 610 Cha Kwo Ling Road, Kowloon
 Tel: 23489211-4 Fax: (852) 27727666

DWG NO. : J856-SD-PW-5313 REV. : D

WINDOW MARK	AW 02
LOCATION	3/F-42/F(4/F,13/F,14/F,24/F,34/F OMITTED) UNIT A1
SECTION	70mm ALUM. SECTION
GLAZING	EGL-1, EGL-1A
QUANTITY	35 Nos.
REMARKS	FAÇADE(TYPE T3PF02 FOR 3/F~42/F)

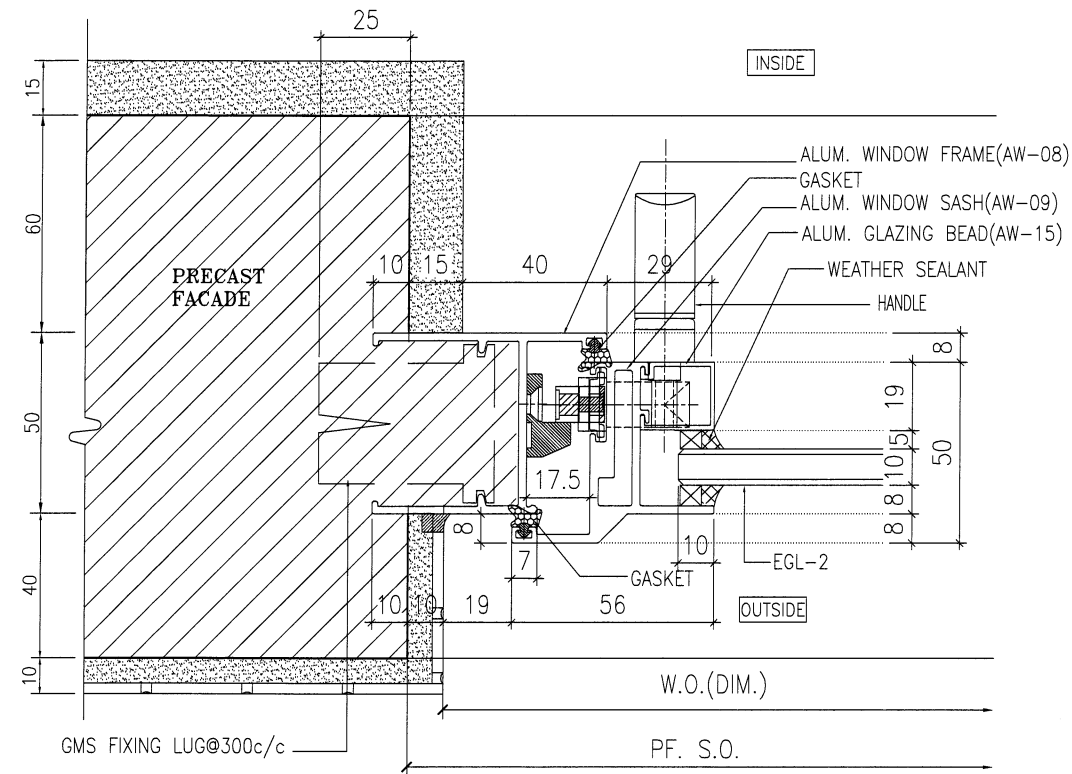

1 HORIZONTAL DETAIL
SCALE 1:2

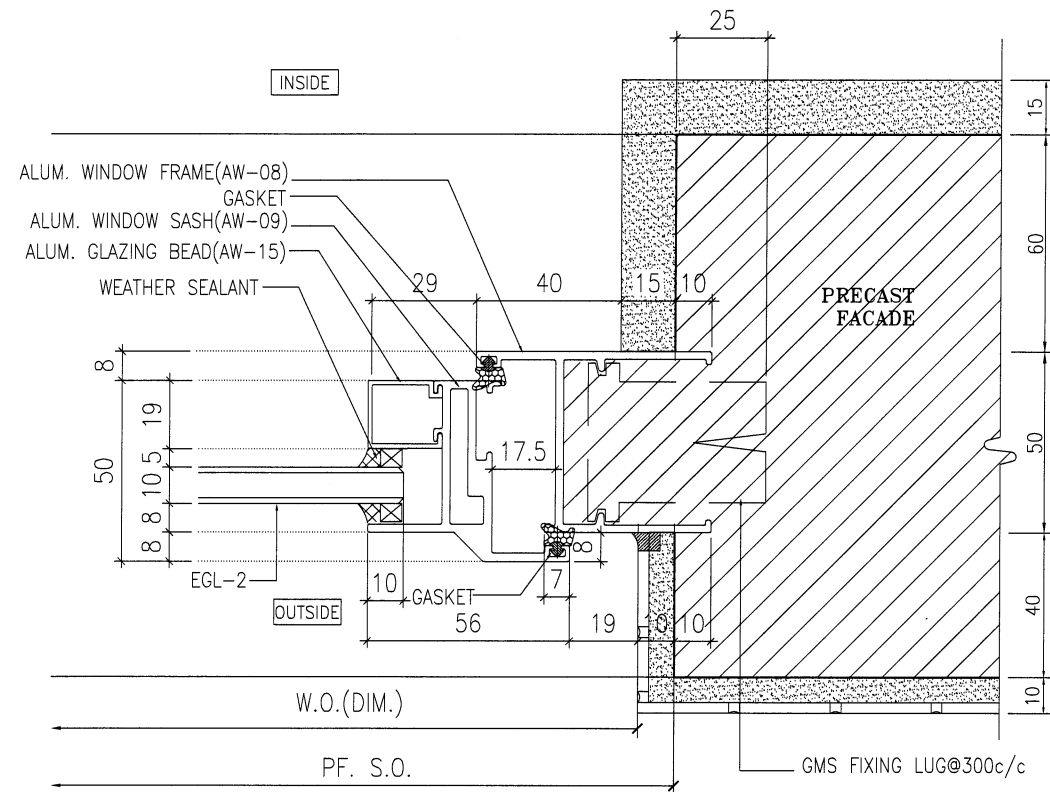

2 HORIZONTAL DETAIL
SCALE 1:2

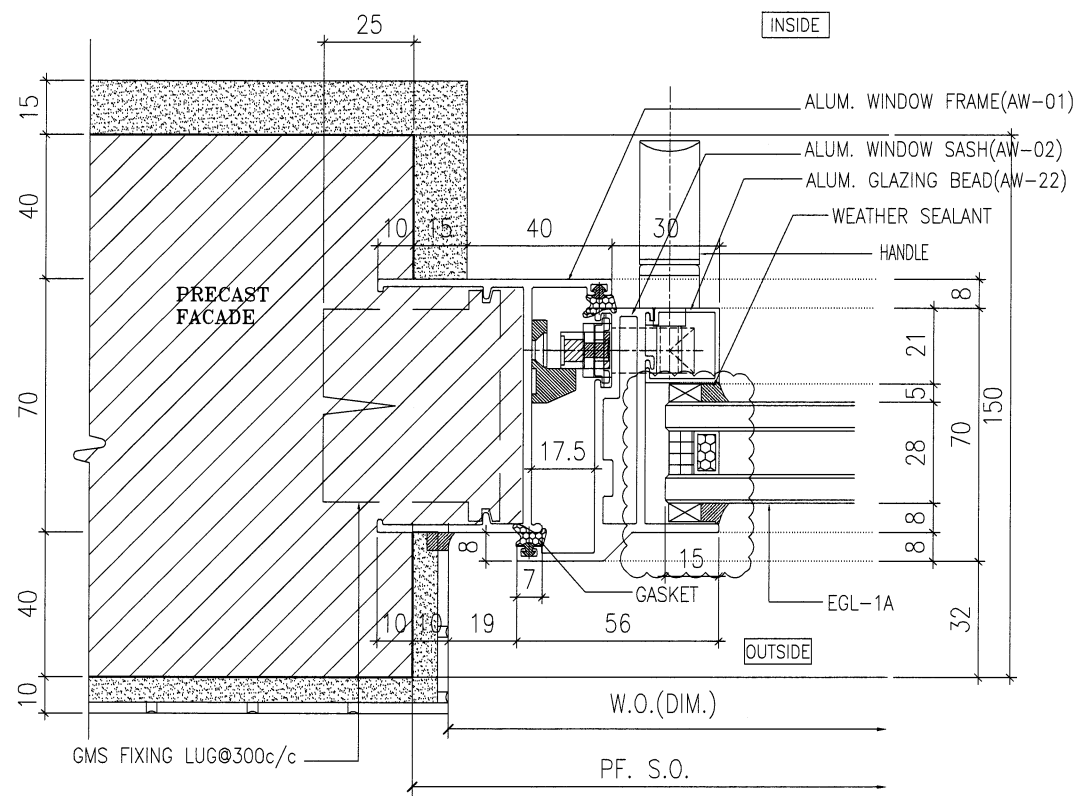

3 HORIZONTAL DETAIL
SCALE 1:2

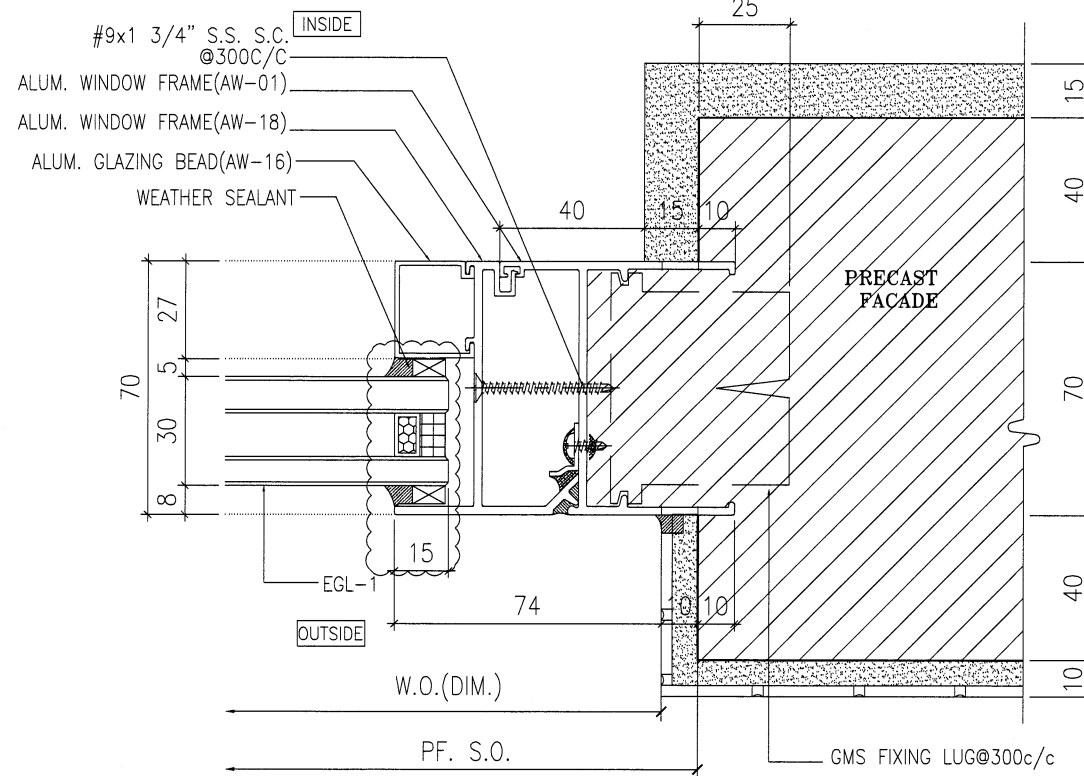

4 HORIZONTAL DETAIL
SCALE 1:2

B.D. REF :
.....

CLIENT :
SUN HUNG KAI
REAL ESTATE AGENCY LTD.
42/F SUN HUNG KAI CENTRE, WANCHAI, HONGKONG

ARCHITECT :
lwk&partners
architects

MAIN CONTRACTOR :
Yee Fai Building Contractors Ltd.

STRUCTURAL ENGINEER :
ARUP

FACADE CONSULTANT :
ALPHA CONSULTING LIMITED
Steel Structure & Facade Specialist

NOTE :
1. ALL DIMENSIONS ARE IN mm.
2. ALL ELEVATIONS ARE VIEWED FROM OUTSIDE.
3. ALL DIMENSIONS TO BE VERIFIED ON SITE BEFORE FABRICATION.

LEGEND :
X1 — DETAIL MARK NO.
X001 — REFER SHEET NO.
1. F.F.L. — FINISHED FLOOR LEVEL
2. S.F.L. — STRUCTURAL FLOOR LEVEL
3. (R) — REVERSED DETAIL
4. GLASS LEGEND
EGL-1—8mmHS+12mm AIR GAP+10mmTP THK. I.G.U.
EGL-2—10mm THK. CLEAR TEMPERED GLASS
EGL-4—10mm THK. TEMPERED ACID ETCHED GLASS
EGL-1A—8mmHS+12mm AIR GAP+8mmTP THK. I.G.U.

B	02/11/2021	REVISION SUBJECT TO ARCH.COMMENT	Ivan
A	30/10/2021	REVISION SUBJECT TO ARCH.COMMENT	Ivan
NO.	DATE	REVISED	BY

JOB NO. : J-856
PROJECT : PROPOSED DEVELOPMENT ABOVE LIGHT RAIL TIN WING STOP, TSWTL NO.23, AREA 33, TIN SHUI WAI, N.T.

TITLE : TYPICAL DETAILS FOR ALUM. WINDOW

DATE : 02-Aug-21 SCALE : 1:40
DRAWN BY : Ivan CHECKED BY :

美特鋁質有限公司
MIDI ALUMINIUM FABRICATOR LTD.
Units 6-8, Sunray Industrial Centre, 1/F
610 Cha Kwo Ling Road, Kowloon
Tel:23489211-4 Fax:(852)2727666

DWG NO. : J856-SD-PW-DT61 REV. : B

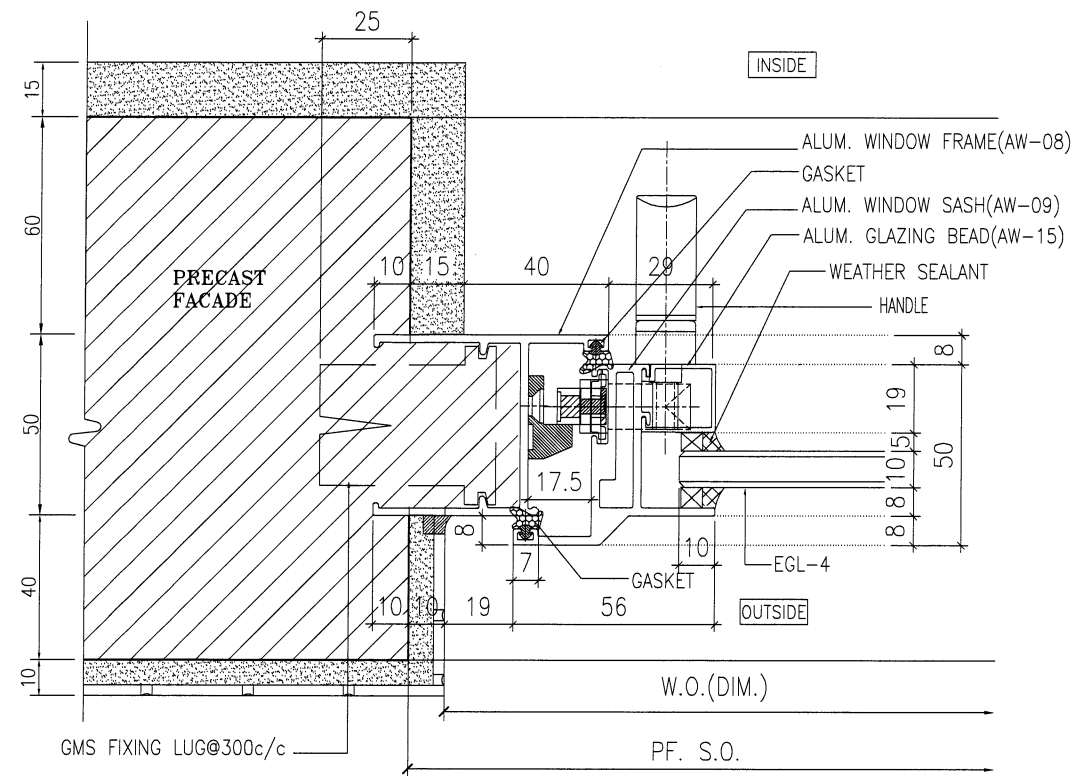

1 HORIZONTAL DETAIL
SCALE 1:2

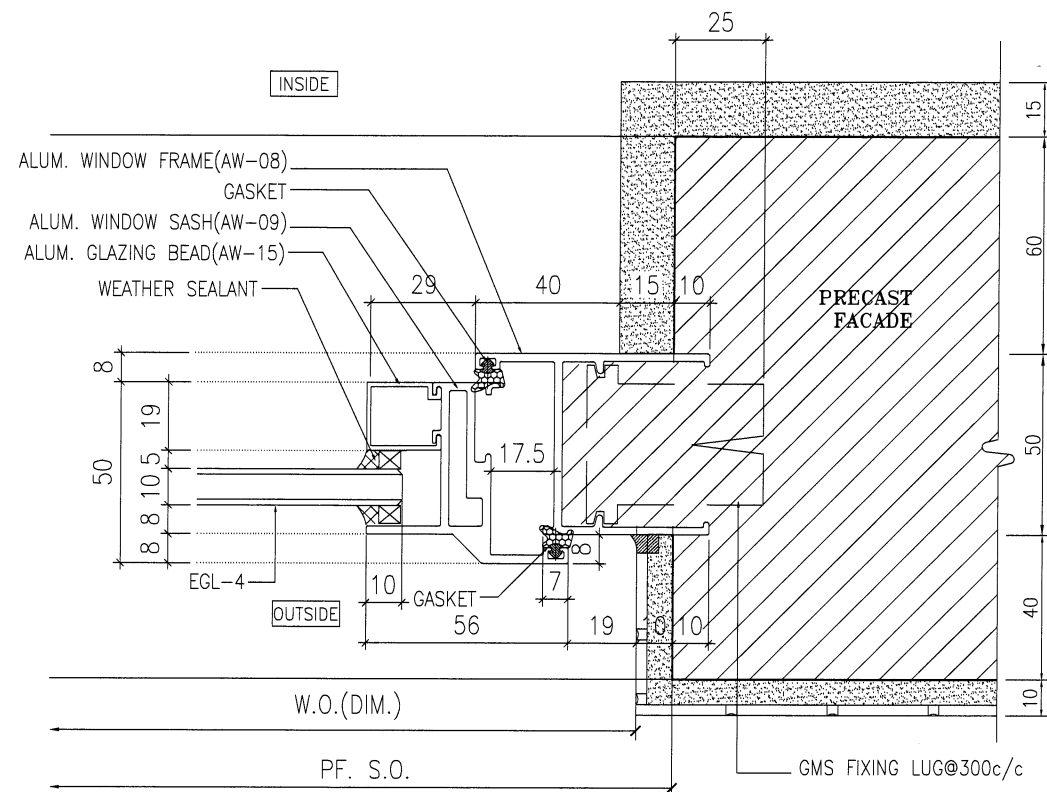

2 HORIZONTAL DETAIL
SCALE 1:2

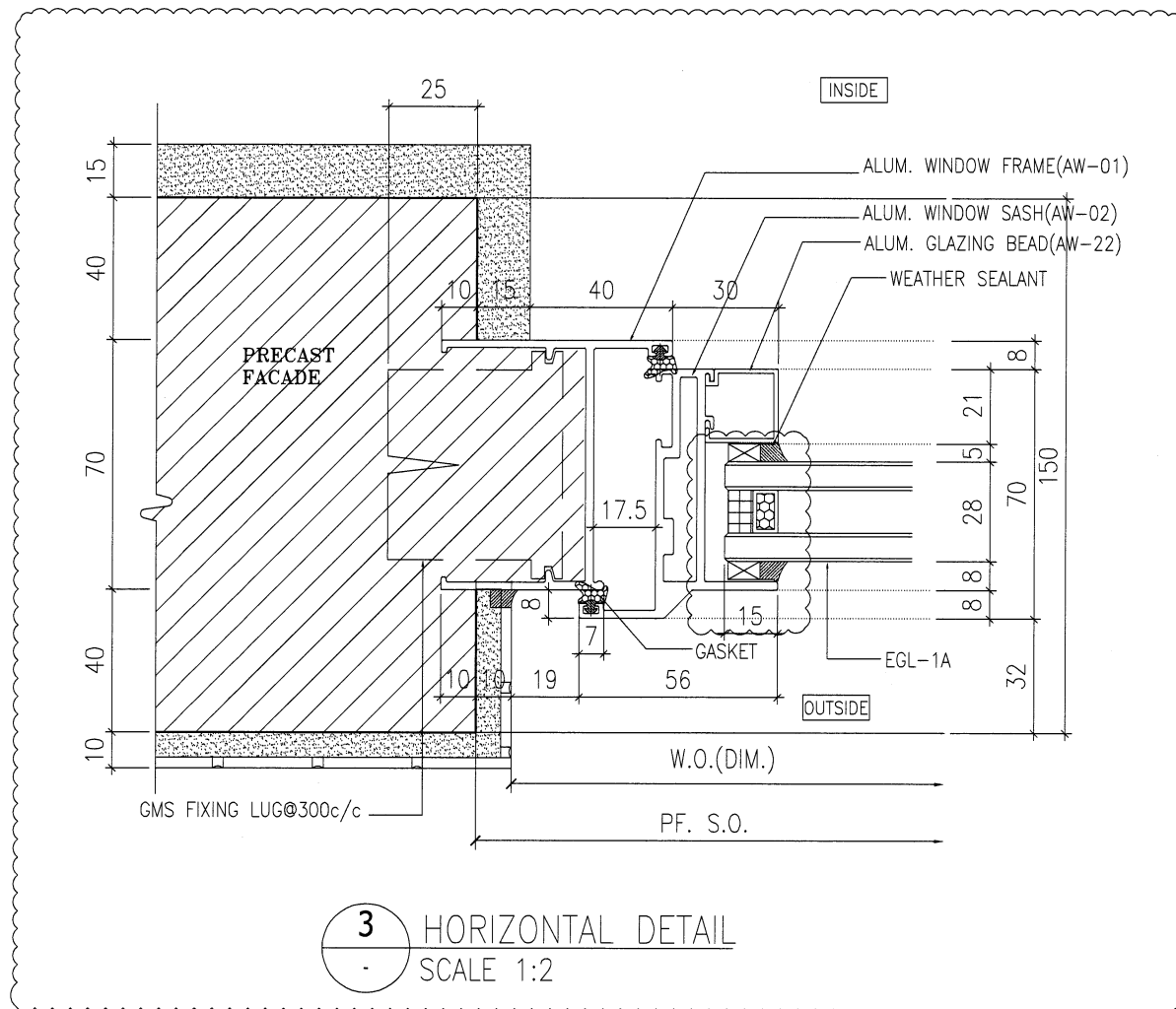

3 HORIZONTAL DETAIL
SCALE 1:2

B.D. REF :

CLIENT :
SUN HUNG KAI
REAL ESTATE AGENCY LTD.
42/F SUN HUNG KAI CENTRE, WANCHAI, HONGKONG

ARCHITECT :
lwk&partners
architects

MAIN CONTRACTOR :
Yee Fai Building Contractors Ltd.

STRUCTURAL ENGINEER :
ARUP

FACADE CONSULTANT:
ALPHA CONSULTING LIMITED
Steel Structure & Facade Specialist

NOTE:
1. ALL DIMENSIONS ARE IN mm.
2. ALL ELEVATIONS ARE VIEWED FROM OUTSIDE.
3. ALL DIMENSIONS TO BE VERIFIED ON SITE BEFORE FABRICATION.

LEGEND:
X1 - DETAIL MARK NO.
X001 - REFER SHEET NO.
1. F.F.L. -- FINISHED FLOOR LEVEL
2. S.F.L. -- STRUCTURAL FLOOR LEVEL
3. (R) -- REVERSED DETAIL
4. GLASS LEGEND
EGL-1 -- 8mmHS+12mm AIR GAP+10mmTP THK. I.G.U.
EGL-2 -- 10mm THK. CLEAR TEMPERED GLASS
EGL-4 -- 10mm THK. TEMPERED ACID ETCHED GLASS
EGL-1A -- 8mmHS+12mm AIR GAP+8mmTP THK. I.G.U.

B	02/11/2021	REVISION SUBJECT TO ARCH.COMMENT	Ivan
A	30/10/2021	REVISION SUBJECT TO ARCH.COMMENT	Ivan
No.	DATE	REVISED	BY

JOB NO. : J-856
PROJECT : PROPOSED DEVELOPMENT ABOVE LIGHT RAIL TIN WING STOP, TSWTL NO.23, AREA 33, TIN SHUI WAI, N.T.

TITLE : TYPICAL DETAILS FOR ALUM. WINDOW

DATE : 02-Aug-21 SCALE : 1:40
DRAWN BY : Ivan CHECKED BY :

英特鋁質有限公司
MIDI ALUMINIUM FABRICATOR LTD.
Units 6-8, Sunray Industrial Centre, 1/F
610 Cha Kwo Ling Road, Kowloon
Tel:23489211-4 Fax:(852)27727666

DWG NO. : J856-SD-PW-DT61a REV. : B

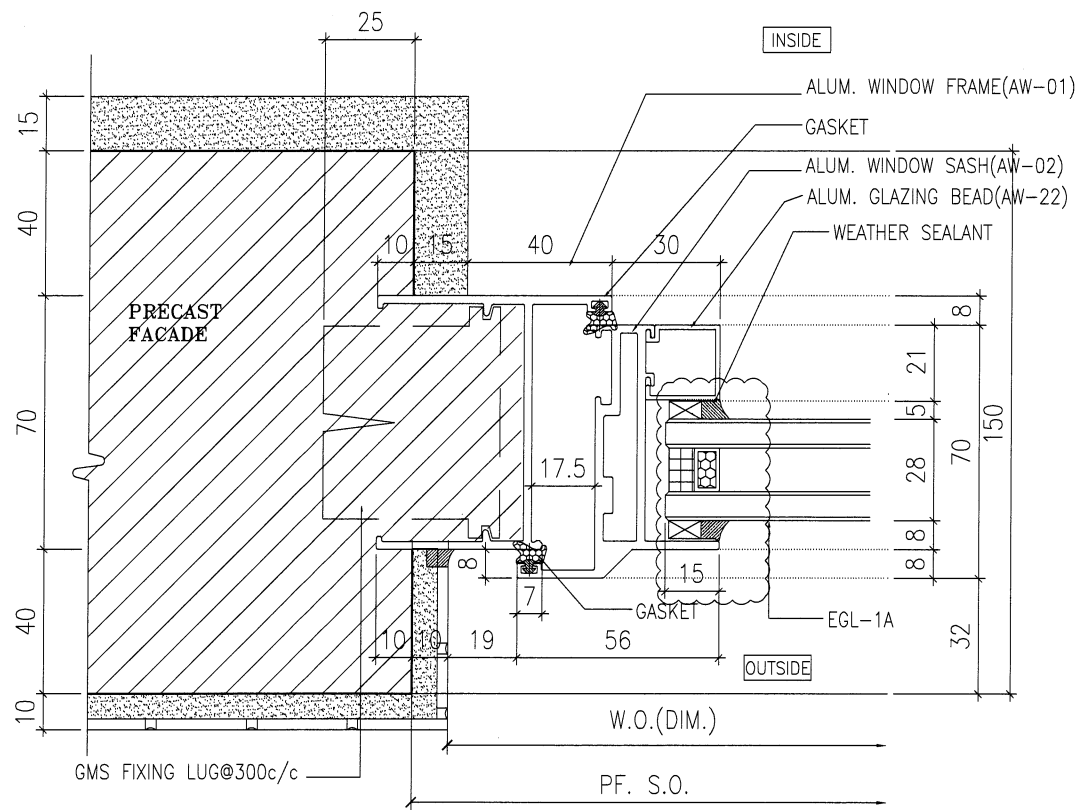

1 HORIZONTAL DETAIL
SCALE 1:2

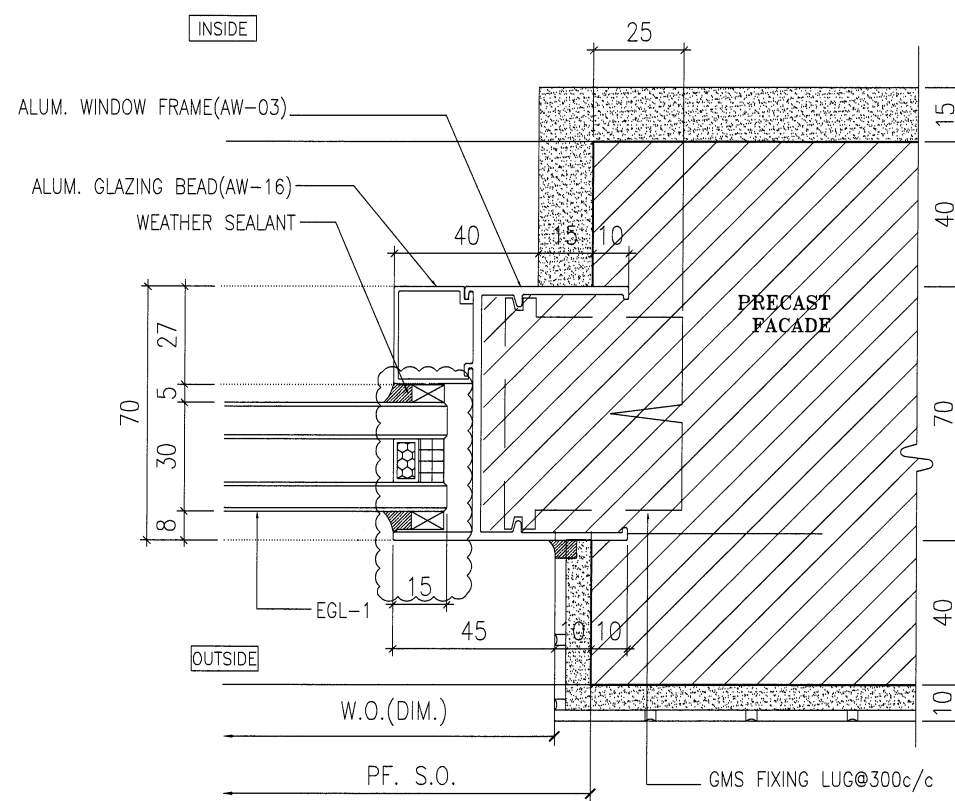

2 HORIZONTAL DETAIL
SCALE 1:2

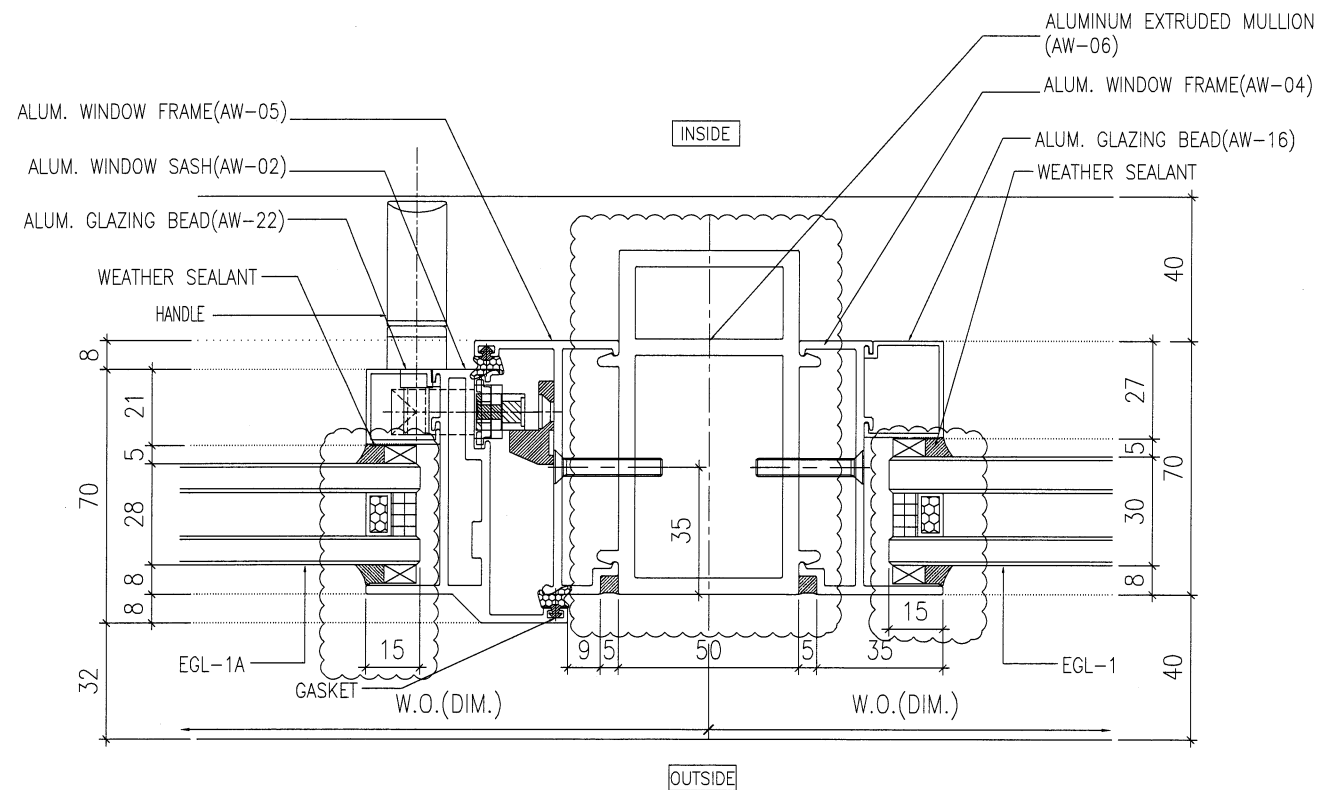

3 HORIZONTAL DETAIL
SCALE 1:2

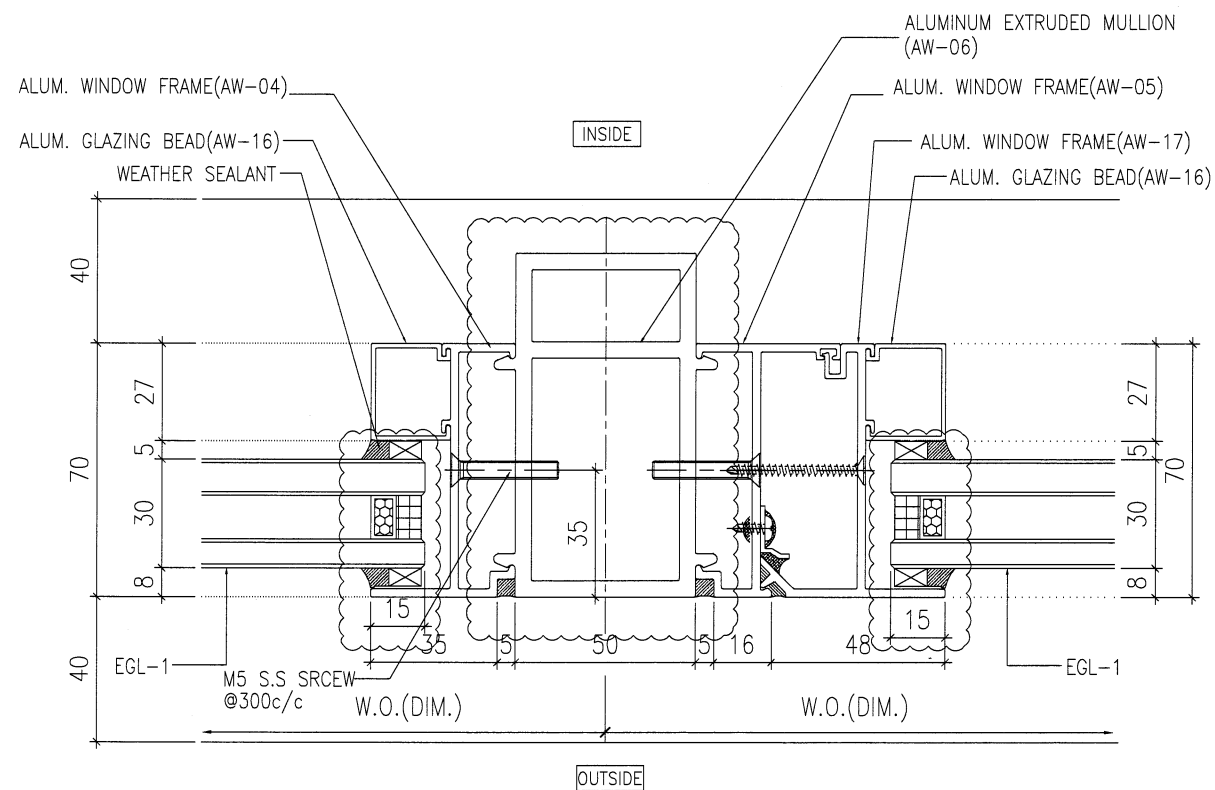

4 HORIZONTAL DETAIL
SCALE 1:2

B.D. REF :

CLIENT :
SUN HUNG KAI
REAL ESTATE AGENCY LTD.
42/F SUN HUNG KAI CENTRE, WANCHAI, HONGKONG

ARCHITECT :
lwk&partners
architects

MAIN CONTRACTOR :
Yee Fai Building Contractors Ltd.

STRUCTURAL ENGINEER :
ARUP

FACADE CONSULTANT:
ALPHA CONSULTING LIMITED
Steel Structure & Facade Specialist

NOTE :
1. ALL DIMENSIONS ARE IN mm.
2. ALL ELEVATIONS ARE VIEWED FROM OUTSIDE.
3. ALL DIMENSIONS TO BE VERIFIED ON SITE BEFORE FABRICATION.

LEGEND :
X1 - DETAIL MARK NO.
X001 - REFER SHEET NO.

1. F.F.L. --- FINISHED FLOOR LEVEL
2. S.F.L. --- STRUCTURAL FLOOR LEVEL
3. (R) --- REVERSED DETAIL
4. GLASS LEGEND
EGL-1--8mmHS+12mm AIR GAP+10mmTP THK. I.G.U.
EGL-2--10mm THK. CLEAR TEMPERED GLASS
EGL-4--10mm THK. TEMPERED ACID ETCHED GLASS
EGL-1A--8mmHS+12mm AIR GAP+8mmTP THK. I.G.U.

NO.	DATE	REVISED	BY
C	02/11/2021	REVISION SUBJECT TO ARCH.COMMENT	ivan
B	30/10/2021	REVISION SUBJECT TO ARCH.COMMENT	ivan
A	30/09/2021	REVISION SUBJECT TO ARCH.COMMENT	ivan

JOB NO. : J-856
PROJECT : PROPOSED DEVELOPMENT ABOVE LIGHT RAIL TIN WING STOP, TSWTL NO.23, AREA 33, TIN SHUI WAI, N.T.

TITLE : TYPICAL DETAILS FOR ALUM. WINDOW

DATE : 02-Aug-21 SCALE : 1:40
DRAWN BY : Ivan CHECKED BY :

美特鋁質有限公司
MIDI ALUMINIUM FABRICATOR LTD.
Units 6-8, Sunray Industrial Centre, 1/F
610 Cha Kwo Ling Road, Kowloon
Tel:23489211-4 Fax:(852)2727666
DWG NO. : J856-SD-PW-DT62 REV. : C

B.D. REF :

CLIENT :
SUN HUNG KAI
 REAL ESTATE AGENCY LTD.
 42/F SUN HUNG KAI CENTRE, WANCHAI, HONGKONG

ARCHITECT :
lwk&partners
 architects

MAIN CONTRACTOR :
怡輝建築有限公司
Yee Fai Building Contractors Ltd.

STRUCTURAL ENGINEER :
ARUP

FAÇADE CONSULTANT:
ALPHA CONSULTING LIMITED
 Steel Structure & Façade Specialist

NOTE:
 1. ALL DIMENSIONS ARE IN mm.
 2. ALL ELEVATIONS ARE VIEWED FROM OUTSIDE.
 3. ALL DIMENSIONS TO BE VERIFIED ON SITE BEFORE FABRICATION.

LEGEND:
 X1 - DETAIL MARK NO.
 X001 - REFER SHEET NO.

1. F.F.L. --- FINISHED FLOOR LEVEL
 2. S.F.L. --- STRUCTURAL FLOOR LEVEL
 3. (R) --- REVERSED DETAIL
 4. GLASS LEGEND
 EGL-1 -- 8mmHS+12mm AIR GAP+10mmTP THK. I.G.U.
 EGL-2 -- 10mm THK. CLEAR TEMPERED GLASS
 EGL-4 -- 10mm THK. TEMPERED ACID ETCHED GLASS
 EGL-1A -- 8mmHS+12mm AIR GAP+8mmTP THK. I.G.U.

NO.	DATE	REVISED	BY
C	02/11/2021	REVISION SUBJECT TO ARCH.COMMENT	Ivan
B	30/10/2021	REVISION SUBJECT TO ARCH.COMMENT	Ivan
A	30/09/2021	REVISION SUBJECT TO ARCH.COMMENT	Ivan

JOB NO. : J-856
 PROJECT :
 PROPOSED DEVELOPMENT ABOVE
 LIGHT RAIL TIN WING STOP, TSWTL
 NO.23, AREA 33, TIN SHUI WAI, N.T.

TITLE :
 TYPICAL DETAILS FOR
 ALUM. WINDOW

DATE : 02-Aug-21 SCALE : 1:40
 DRAWN BY : Ivan CHECKED BY :

美特鋁質有限公司
MIDI ALUMINIUM FABRICATOR LTD.
 Units 6-8, Sunray Industrial Centre, 1/F
 610 Cha Kwo Ling Road, Kowloon
 Tel:23489211-4 Fax:(852)27727666
 DWG NO. : J856-SD-PW-DT63 REV. : C

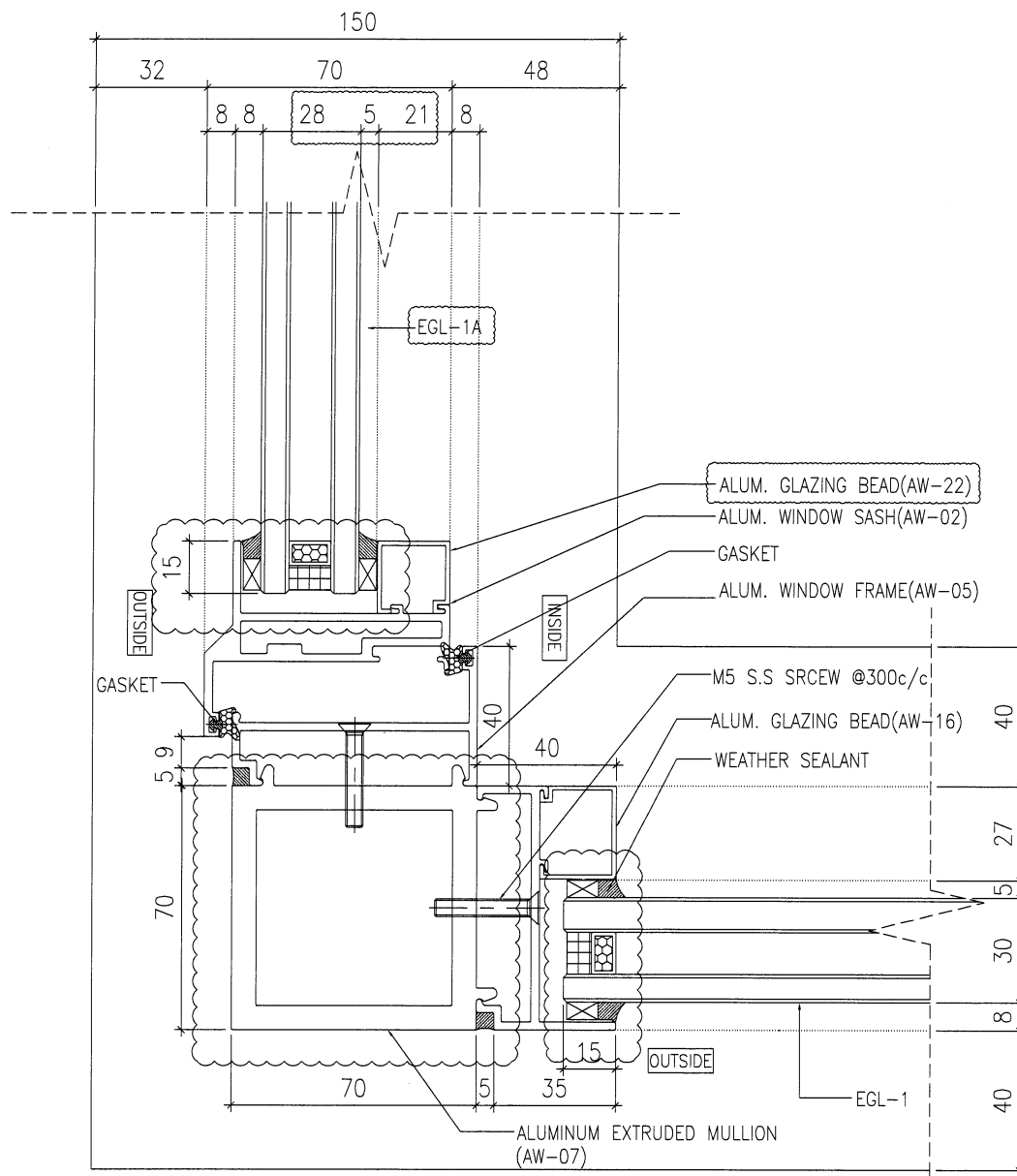

1 HORIZONTAL DETAIL
 SCALE 1:2

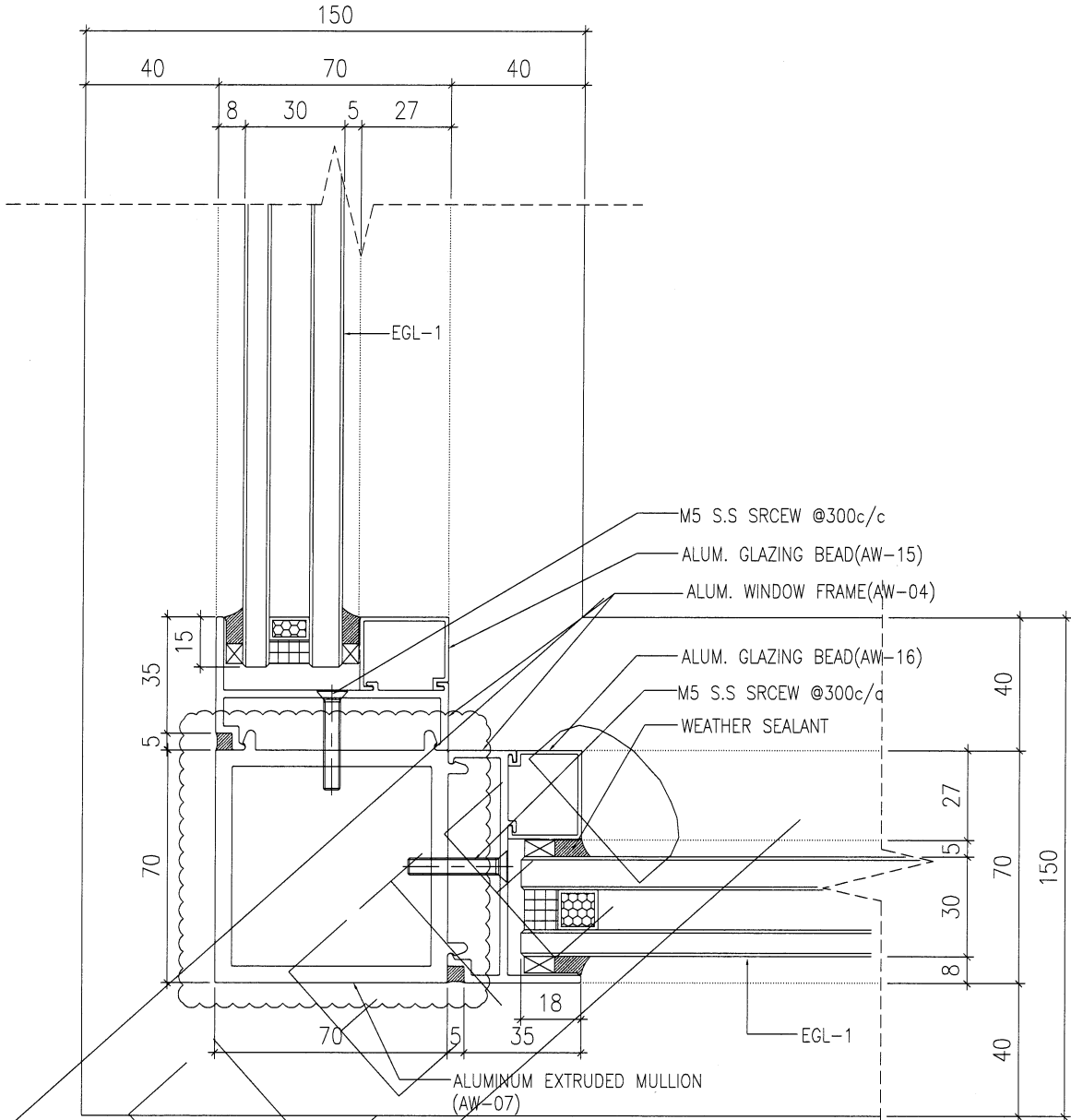

2 HORIZONTAL DETAIL
 SCALE 1:2

B.D. REF :

CLIENT :
SUN HUNG KAI
 REAL ESTATE AGENCY LTD.
 42/F SUN HUNG KAI CENTRE, WANCHAI, HONGKONG

ARCHITECT :
lwk&partners
 architects

MAIN CONTRACTOR :
Yee Fal Building Contractors Ltd.

STRUCTURAL ENGINEER :
ARUP

FACADE CONSULTANT:
ALPHA CONSULTING LIMITED
 Steel Structure & Facade Specialist

NOTE :
 1. ALL DIMENSIONS ARE IN mm.
 2. ALL ELEVATIONS ARE VIEWED FROM OUTSIDE.
 3. ALL DIMENSIONS TO BE VERIFIED ON SITE BEFORE FABRICATION.

LEGEND :
 X1 --- DETAIL MARK NO.
 X001 --- REFER SHEET NO.

1. F.F.L. --- FINISHED FLOOR LEVEL
 2. S.F.L. --- STRUCTURAL FLOOR LEVEL
 3. (R) --- REVERSED DETAIL
 4. GLASS LEGEND
 EGL-1 --- 8mmHS+12mm AIR GAP+10mmTP THK. I.G.U.
 EGL-2 --- 10mm THK. CLEAR TEMPERED GLASS
 EGL-4 --- 10mm THK. TEMPERED ACID ETCHED GLASS
 EGL-1A --- 8mmHS+12mm AIR GAP+8mmTP THK. I.G.U.

NO.	DATE	REVISION	REVISD	BY
D	02/11/2021	REVISION SUBJECT TO ARCH.COMMENT		ivan
C	30/10/2021	REVISION SUBJECT TO ARCH.COMMENT		ivan
B	18/10/2021	REVISION SUBJECT TO ARCH.COMMENT		ivan
A	30/09/2021	REVISION SUBJECT TO ARCH.COMMENT		ivan

JOB NO. : J-856
 PROJECT : PROPOSED DEVELOPMENT ABOVE LIGHT RAIL TIN WING STOP, TSWTL NO.23, AREA 33, TIN SHUI WAI, N.T.

TITLE : TYPICAL DETAILS FOR ALUM. WINDOW

DATE : 02-Aug-21 SCALE : 1:40

DRAWN BY : Ivan CHECKED BY :

美特鋁質有限公司
MIDI ALUMINIUM FABRICATOR LTD.
 Units 6-8, Sunray Industrial Centre, 1/F
 610 Cha Kwo Ling Road, Kowloon
 Tel: 23489211-4 Fax: (852) 27727666

DWG NO. : J856-SD-PW-DT64 REV. : D

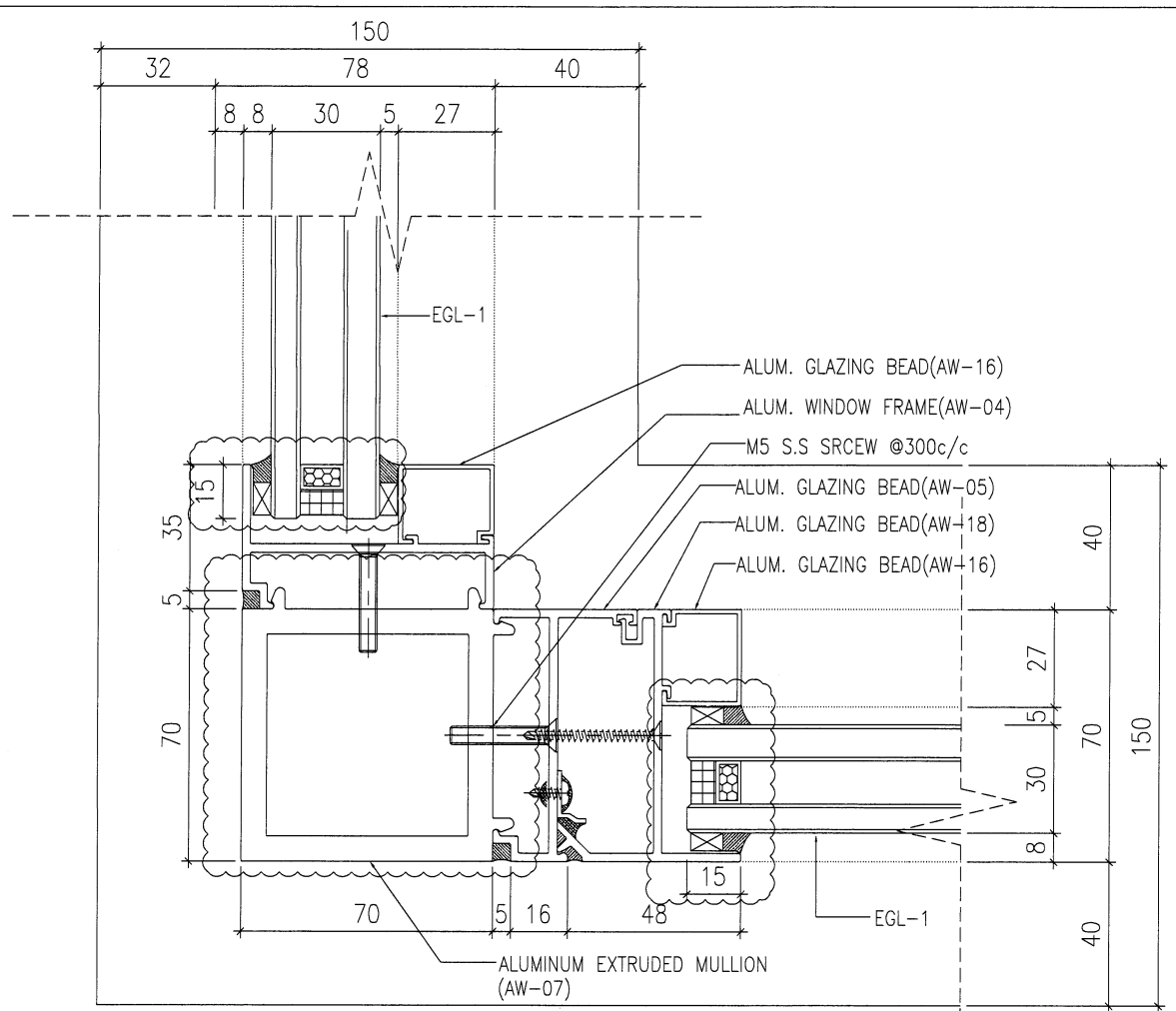

1 HORIZONTAL DETAIL
 SCALE 1:2

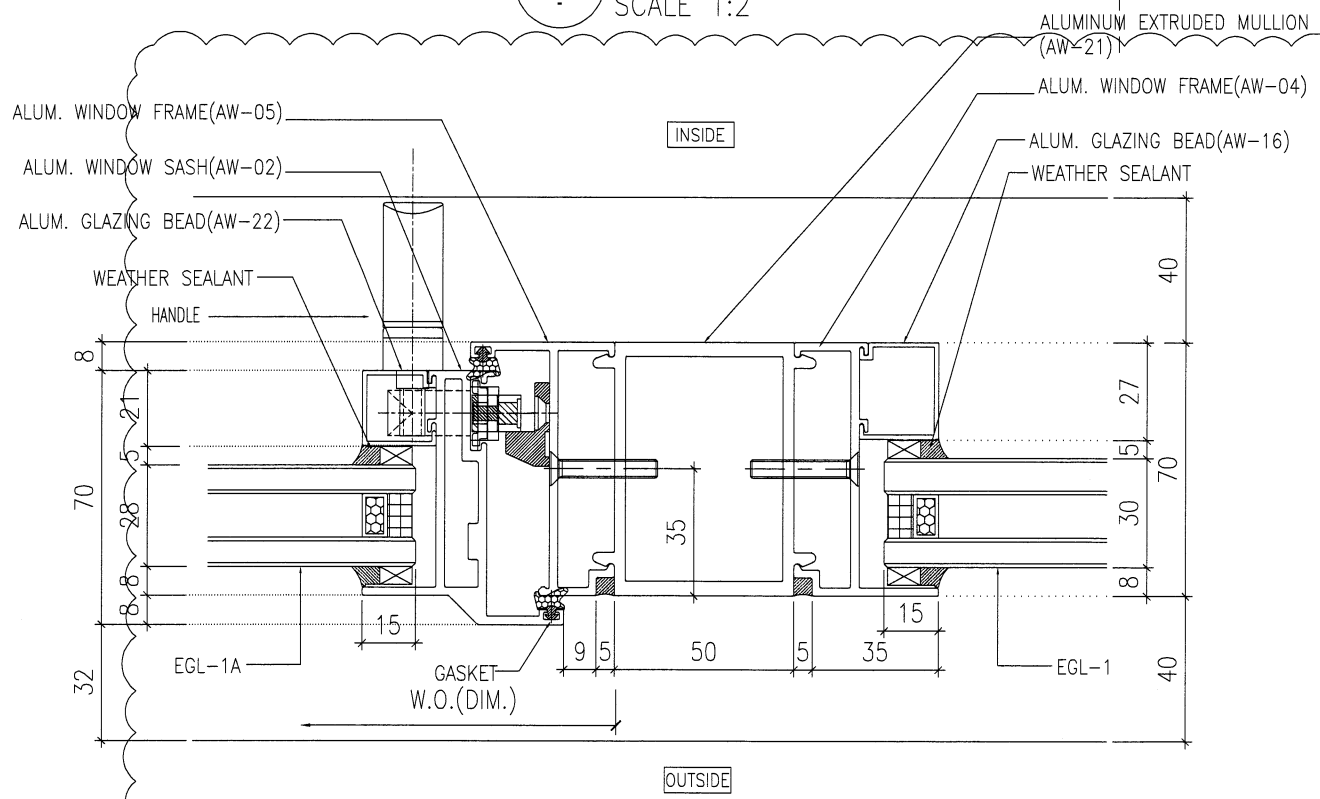

2 HORIZONTAL DETAIL
 SCALE 1:2

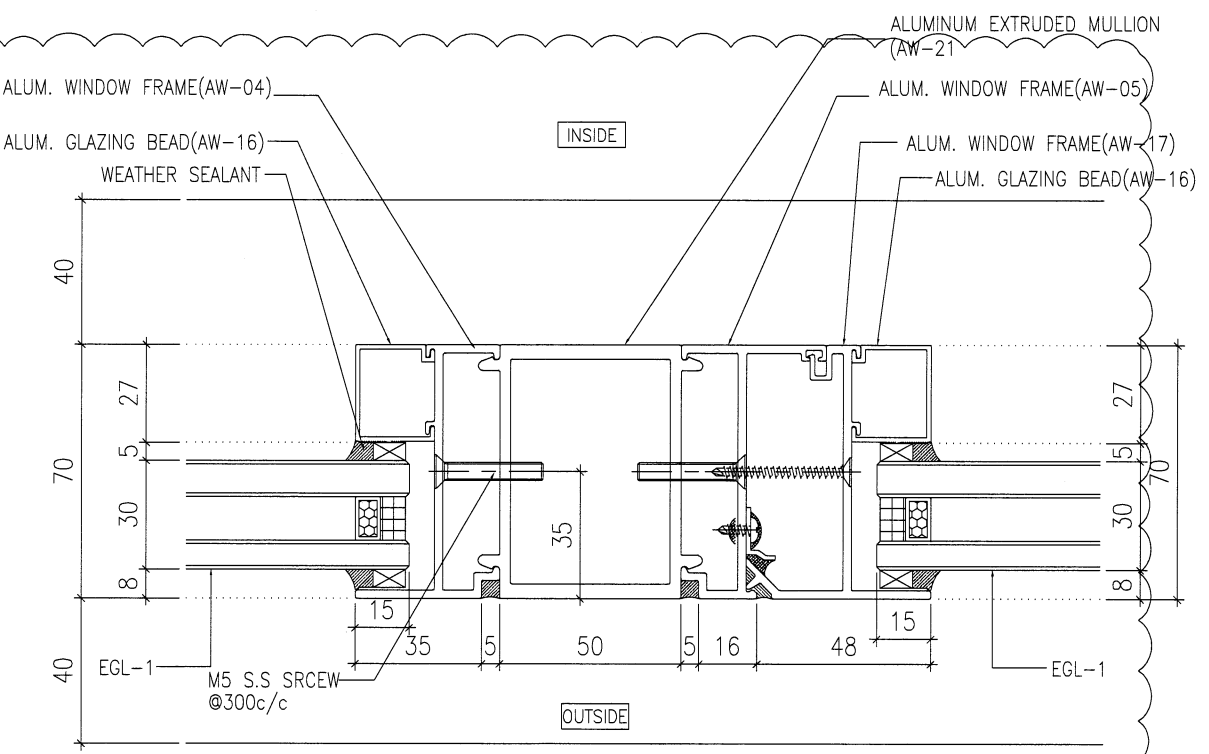

3 HORIZONTAL DETAIL
 SCALE 1:2

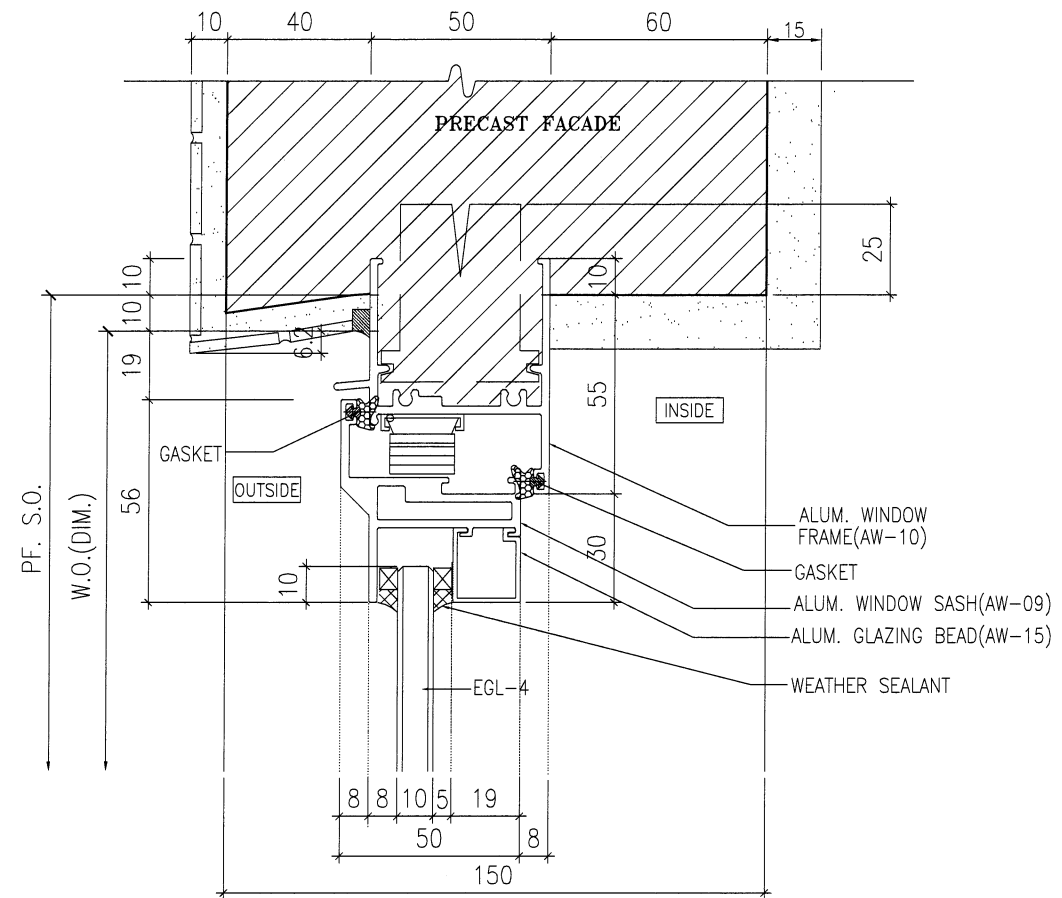

1 HORIZONTAL DETAIL
SCALE 1:2
150

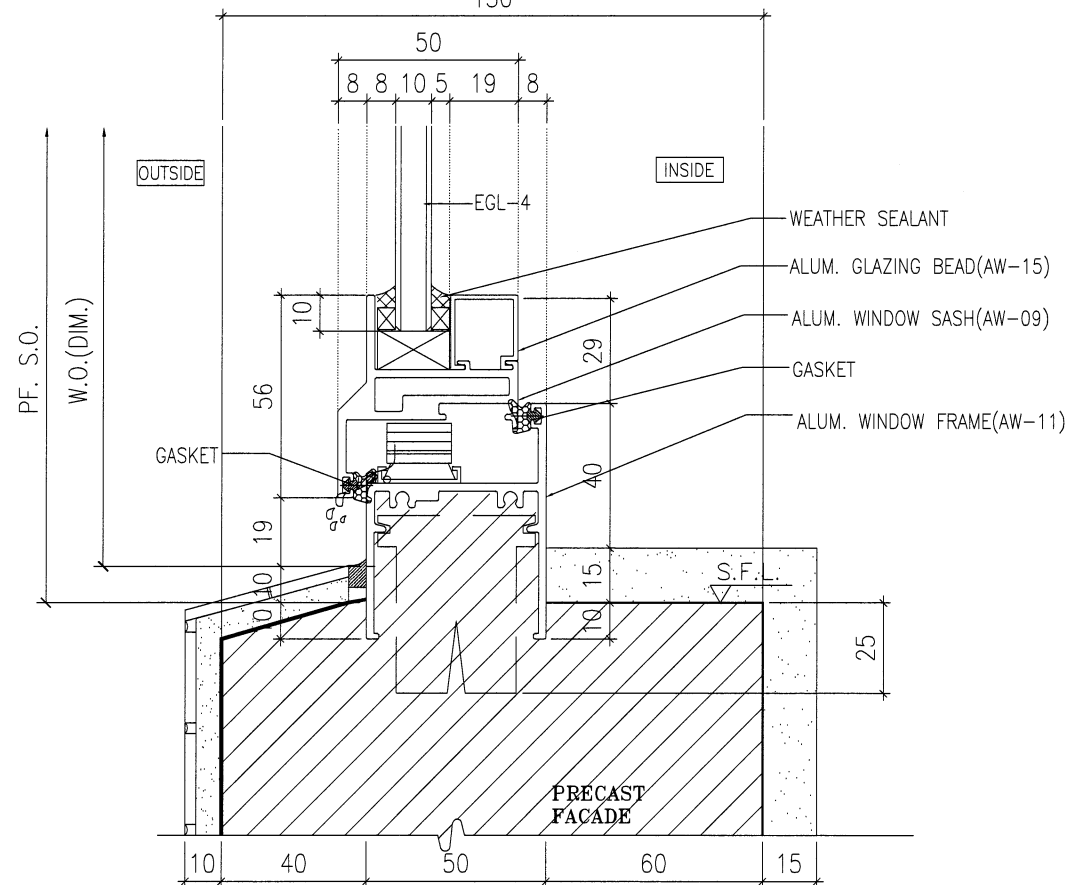

2 HORIZONTAL DETAIL
SCALE 1:2
150

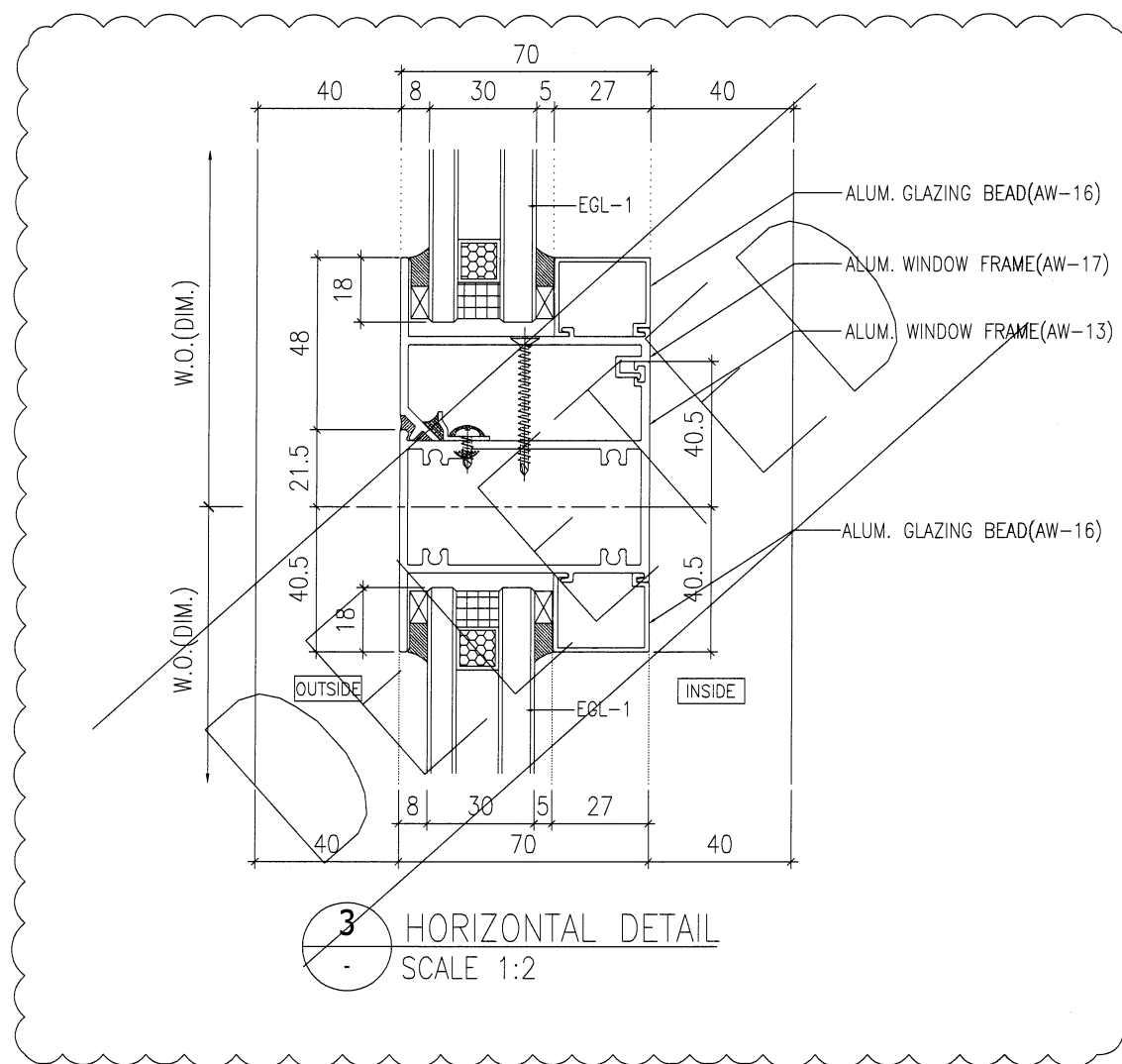

3 HORIZONTAL DETAIL
SCALE 1:2
150

B.D. REF :
CLIENT :
ARCHITECT :
MAIN CONTRACTOR :
STRUCTURAL ENGINEER :
FACADE CONSULTANT :

SUN HUNG KAI
REAL ESTATE AGENCY LTD.
42/F SUN HUNG KAI CENTRE, WANCHAI, HONGKONG

lwk&partners
architects

Yee Fai Building Contractors Ltd.

ARUP

ALPHA CONSULTING LIMITED
Steel Structure & Facade Specialist

NOTE:
1. ALL DIMENSIONS ARE IN mm.
2. ALL ELEVATIONS ARE VIEWED FROM OUTSIDE.
3. ALL DIMENSIONS TO BE VERIFIED ON SITE BEFORE FABRICATION.

LEGEND:
X1 - DETAIL MARK NO.
X001 - REFER SHEET NO.
1. F.F.L. --- FINISHED FLOOR LEVEL
2. S.F.L. --- STRUCTURAL FLOOR LEVEL
3. (R) --- REVERSED DETAIL
4. GLASS LEGEND
EGL-1--8mmHS+12mm AIR GAP+10mmTP THK. I.G.U.
EGL-2--10mm THK. CLEAR TEMPERED GLASS
EGL-4--10mm THK. TEMPERED ACID ETCHED GLASS
EGL-1A--8mmHS+12mm AIR GAP+8mmTP THK. I.G.U.

B	02/11/2021	REVISION SUBJECT TO ARCH.COMMENT	lvon
A	30/10/2021	REVISION SUBJECT TO ARCH.COMMENT	lvon
NO.	DATE	REVISED	BY

JOB NO. : J-856
PROJECT : PROPOSED DEVELOPMENT ABOVE LIGHT RAIL TIN WING STOP, TSWTL NO.23, AREA 33, TIN SHUI WAI, N.T.

TITLE : TYPICAL DETAILS FOR ALUM. WINDOW

DATE : 02-Aug-21 SCALE : 1:40

DRAWN BY : lvon CHECKED BY :

英特鋁質有限公司
MIDI ALUMINIUM FABRICATOR LTD.
Units 6-8, Sunray Industrial Centre, 1/F
610 Cho Kwo Ling Road, Kowloon
Tel:23489211-4 Fax:(852)2727666

DWG NO. : J856-SD-PW-DT71a REV. : B

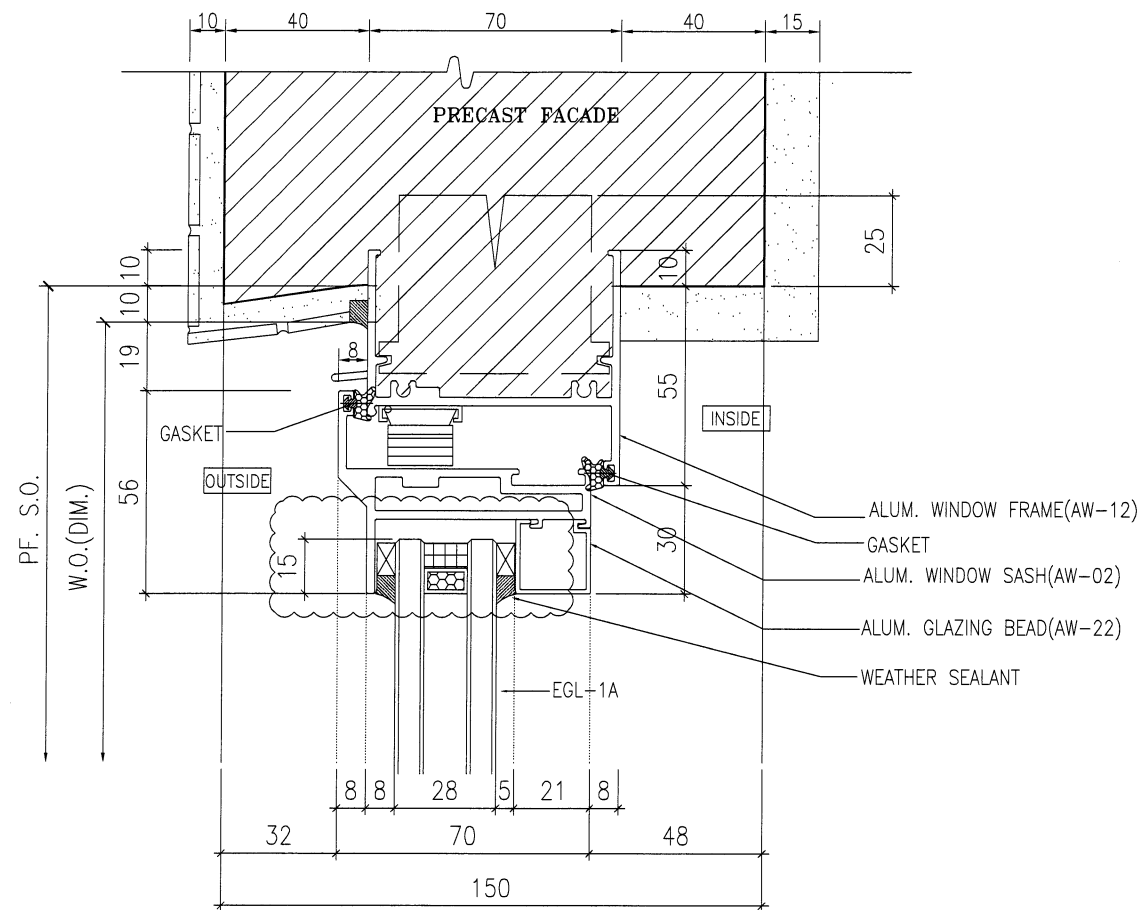

1 HORIZONTAL DETAIL
SCALE 1:2

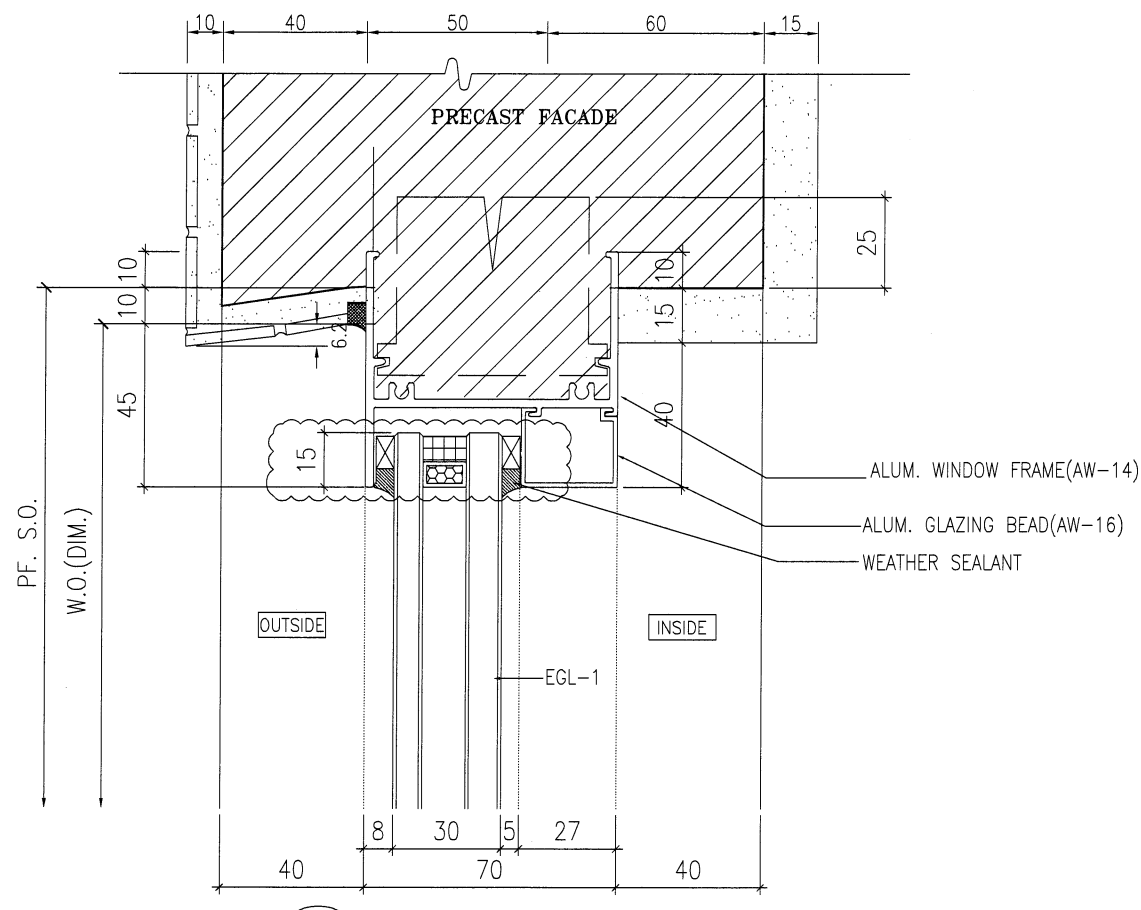

3 HORIZONTAL DETAIL
SCALE 1:2

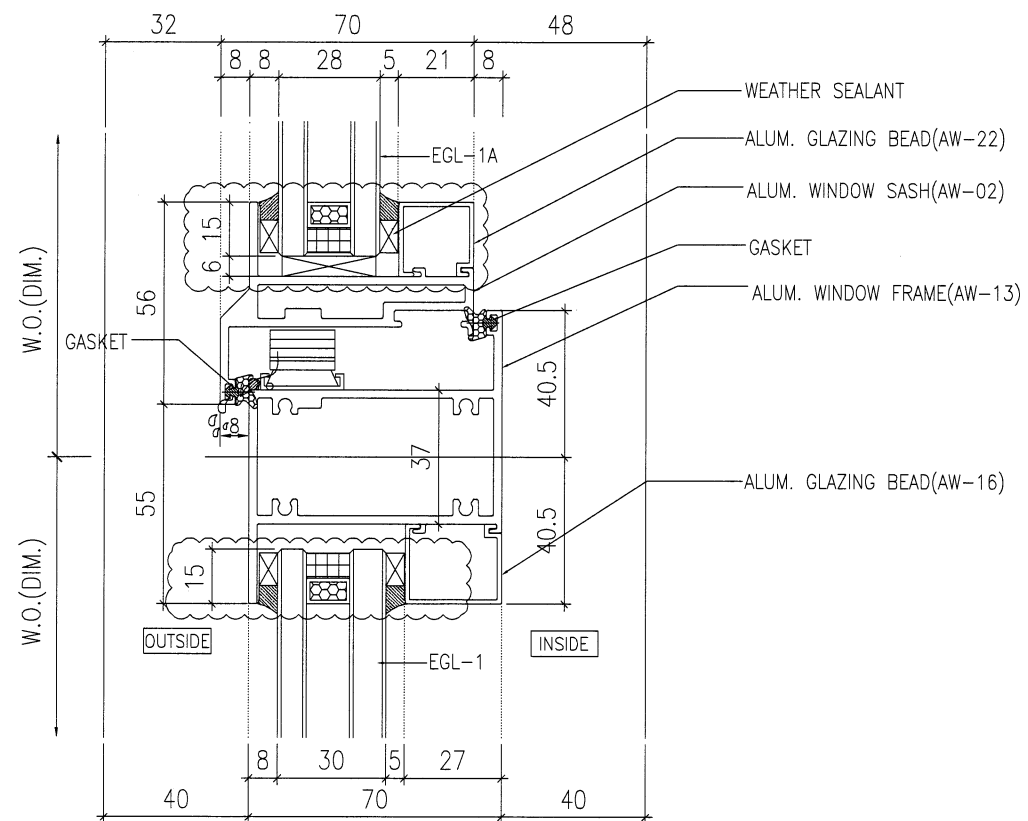

2 HORIZONTAL DETAIL
SCALE 1:2

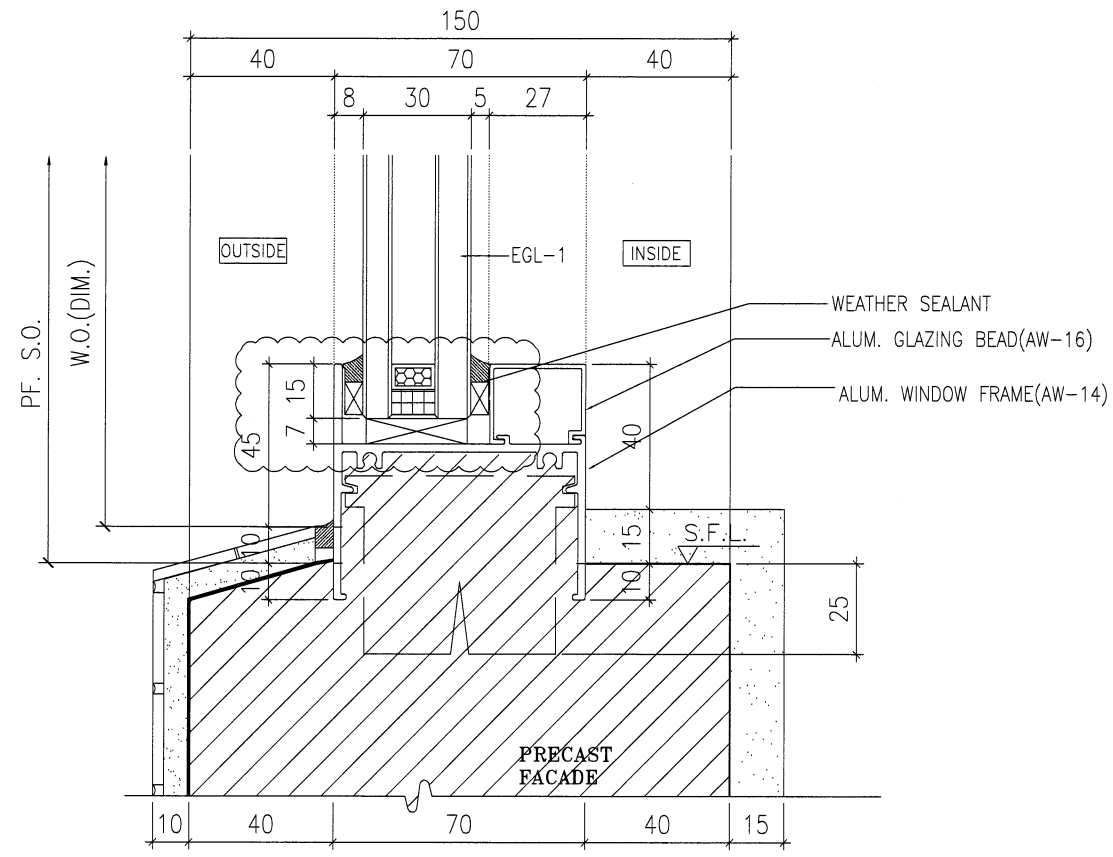

4 HORIZONTAL DETAIL
SCALE 1:2

B.D. REF :

CLIENT :

SUN HUNG KAI
REAL ESTATE AGENCY LTD.
42/F SUN HUNG KAI CENTRE, WANCHAI, HONGKONG

ARCHITECT :

lwk&partners
architects

MAIN CONTRACTOR :

怡輝建築有限公司
Yee Fai Building Contractors Ltd.

STRUCTURAL ENGINEER :

ARUP

FACADE CONSULTANT:

ALPHA CONSULTING LIMITED
Steel Structure & Facade Specialist

NOTE :

1. ALL DIMENSIONS ARE IN mm.
2. ALL ELEVATIONS ARE VIEWED FROM OUTSIDE.
3. ALL DIMENSIONS TO BE VERIFIED ON SITE BEFORE FABRICATION.

LEGEND :

- X1 - DETAIL MARK NO.
- X001 - REFER SHEET NO.

1. F.F.L. -- FINISHED FLOOR LEVEL
2. S.F.L. -- STRUCTURAL FLOOR LEVEL
3. (R) -- REVERSED DETAIL
4. GLASS LEGEND
EGL-1--8mmHS+12mm AIR GAP+10mmTP THK. I.G.U.
EGL-2--10mm THK. CLEAR TEMPERED GLASS
EGL-4--10mm THK. TEMPERED ACID ETCHED GLASS
EGL-1A--8mmHS+12mm AIR GAP+8mmTP THK. I.G.U.

B	02/11/2021	REVISION SUBJECT TO ARCH.COMMENT	Ivan
A	30/10/2021	REVISION SUBJECT TO ARCH.COMMENT	Ivan
NO.	DATE	REVISED	BY

JOB NO. : J-856
PROJECT : PROPOSED DEVELOPMENT ABOVE LIGHT RAIL TIN WING STOP, TSWTL NO.23, AREA 33, TIN SHUI WAI, N.T.

TITLE : TYPICAL DETAILS FOR ALUM. WINDOW

DATE : 02-Aug-21 SCALE : 1:40

DRAWN BY : Ivan CHECKED BY :

英特鋁質有限公司
MIDI ALUMINUM FABRICATOR LTD.
Units 6-8, Sunray Industrial Centre, 1/F
610 Cha Kwo Ling Road, Kowloon
Tel:23489211-4 Fax:(852)27727666

DWG NO. : J856-SD-PW-DT72 REV. : B

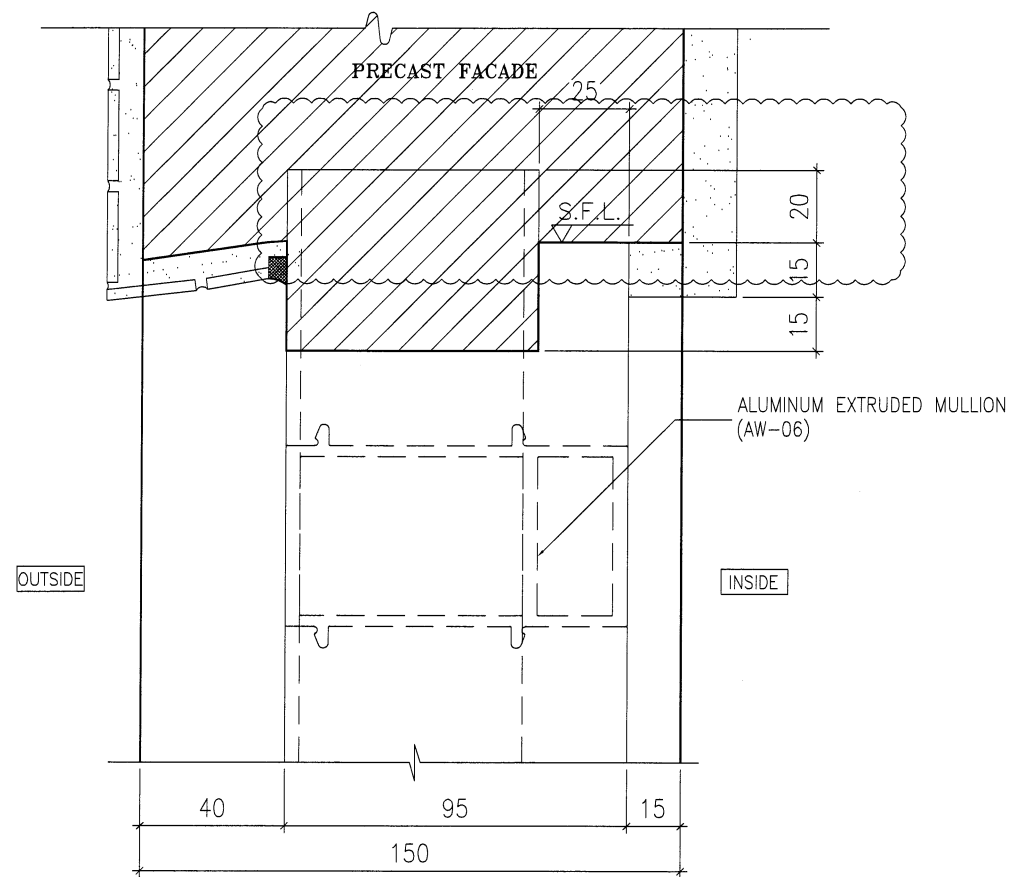

1 HORIZONTAL DETAIL
SCALE 1:2

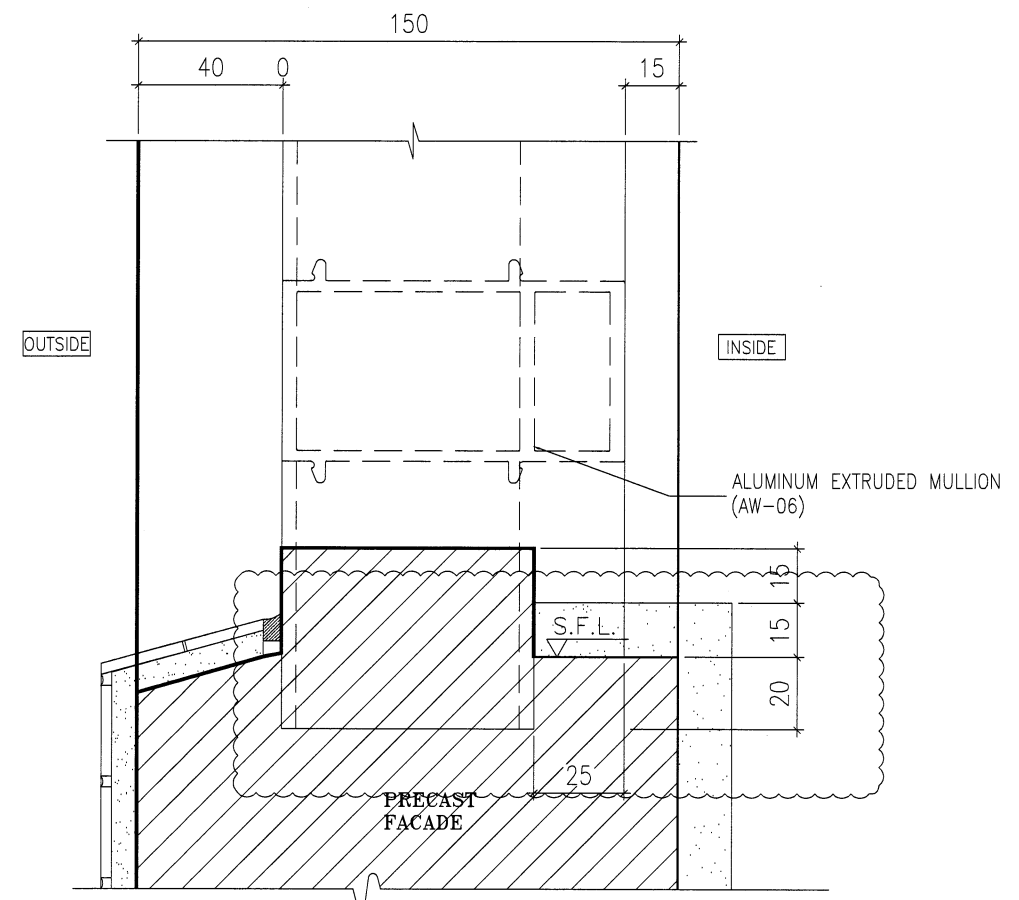

2 HORIZONTAL DETAIL
SCALE 1:2

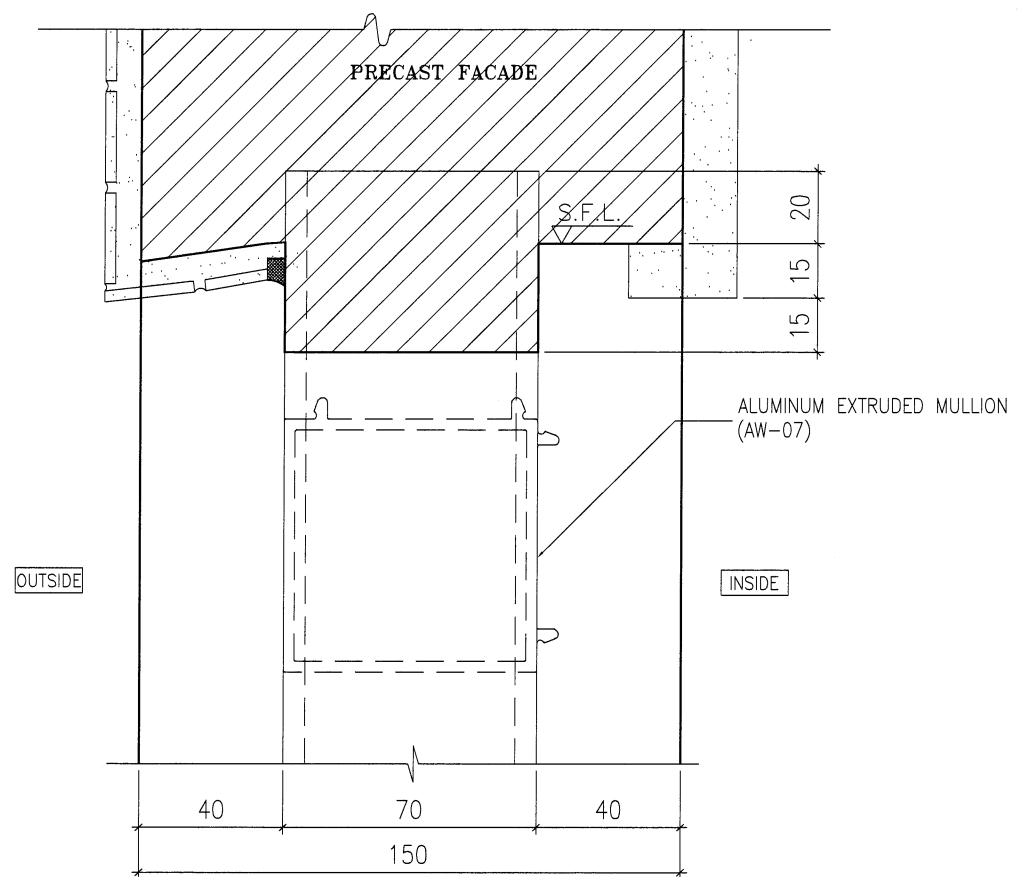

3 HORIZONTAL DETAIL
SCALE 1:2

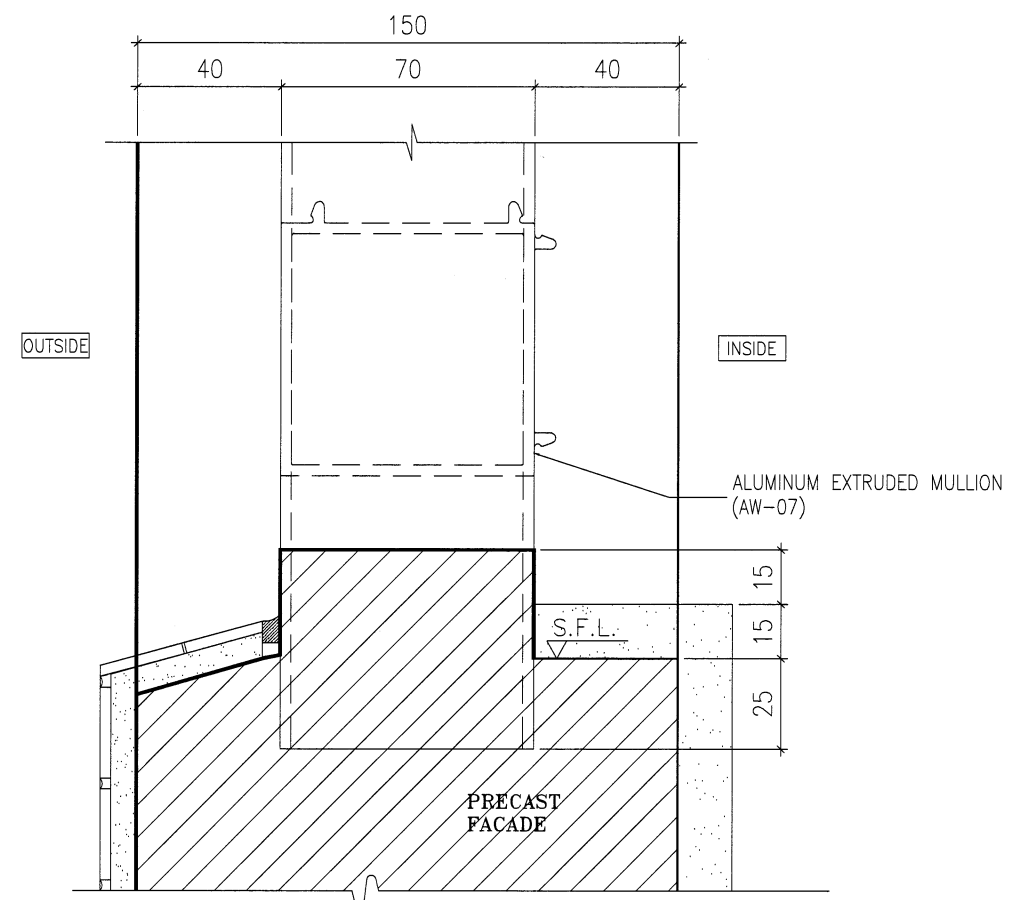

4 HORIZONTAL DETAIL
SCALE 1:2

B.D. REF :

CLIENT :
SUN HUNG KAI
REAL ESTATE AGENCY LTD.
42/F SUN HUNG KAI CENTRE, WANCHAI, HONGKONG

ARCHITECT :
lwk&partners
architects

MAIN CONTRACTOR :
Yee Fai Building Contractors Ltd.

STRUCTURAL ENGINEER :
ARUP

FACADE CONSULTANT:
ALPHA CONSULTING LIMITED
Steel Structure & Facade Specialist

NOTE :
1. ALL DIMENSIONS ARE IN mm.
2. ALL ELEVATIONS ARE VIEWED FROM OUTSIDE.
3. ALL DIMENSIONS TO BE VERIFIED ON SITE BEFORE FABRICATION.

LEGEND :
X1 - DETAIL MARK NO.
X001 - REFER SHEET NO.
1. F.F.L. -- FINISHED FLOOR LEVEL
2. S.F.L. -- STRUCTURAL FLOOR LEVEL
3. (R) -- REVERSED DETAIL
4. GLASS LEGEND
EGL-1--8mmHS+12mm AIR GAP+10mmTP THK. I.G.U.
EGL-2--10mm THK. CLEAR TEMPERED GLASS
EGL-4--10mm THK. TEMPERED ACID ETCHED GLASS
EGL-1A--8mmHS+12mm AIR GAP+8mmTP THK. I.G.U.

NO.	DATE	REVISED	BY
C	02/11/2021	REVISION SUBJECT TO ARCH.COMMENT	Ivan
B	30/10/2021	REVISION SUBJECT TO ARCH.COMMENT	Ivan
A	30/09/2021	REVISION SUBJECT TO ARCH.COMMENT	Ivan

JOB NO. : J-856
PROJECT : PROPOSED DEVELOPMENT ABOVE LIGHT RAIL TIN WING STOP, TSWTL NO.23, AREA 33, TIN SHUI WAI, N.T.

TITLE : TYPICAL DETAILS FOR ALUM. WINDOW

DATE : 02-Aug-21 SCALE : 1:40

DRAWN BY : Ivan CHECKED BY :

英特鋁質有限公司
MIDI ALUMINIUM FABRICATOR LTD.
Units 6-8, Sunray Industrial Centre, 1/F
610 Cha Kwo Ling Road, Kowloon
Tel:23489211-4 Fax:(852)27727666

DWG NO. : J856-SD-PW-DT73 REV. : C

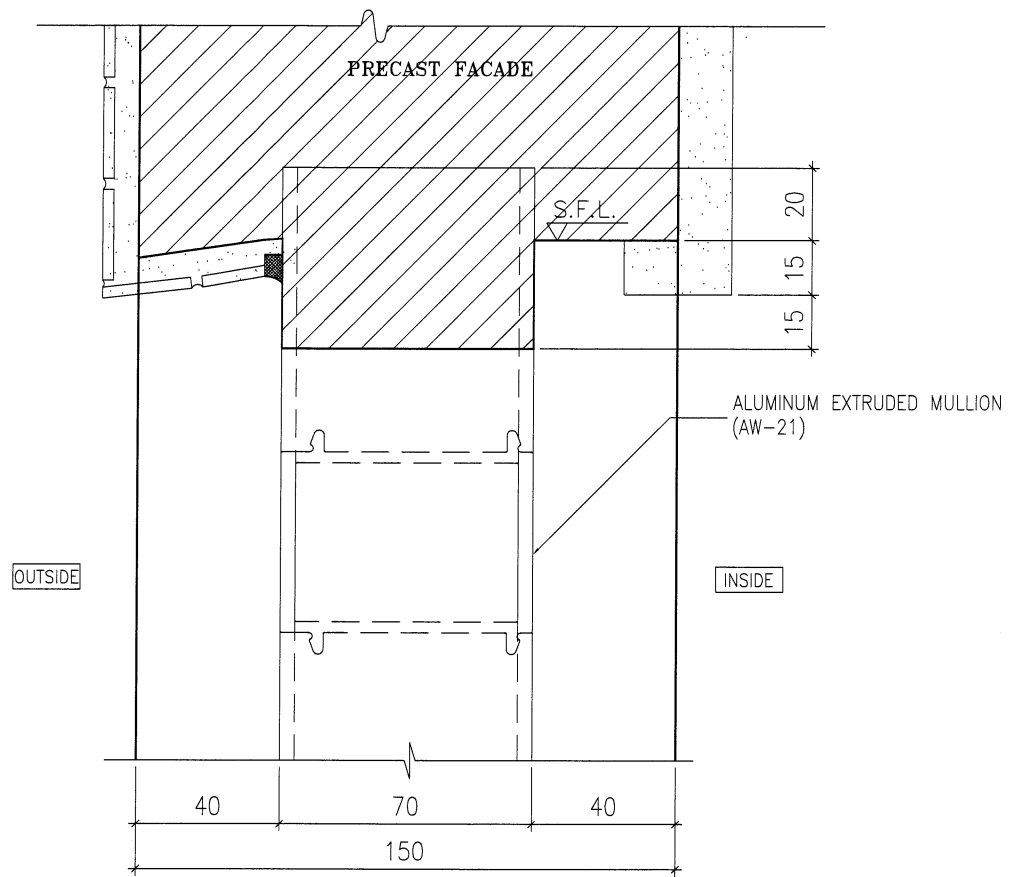

1 HORIZONTAL DETAIL
SCALE 1:2

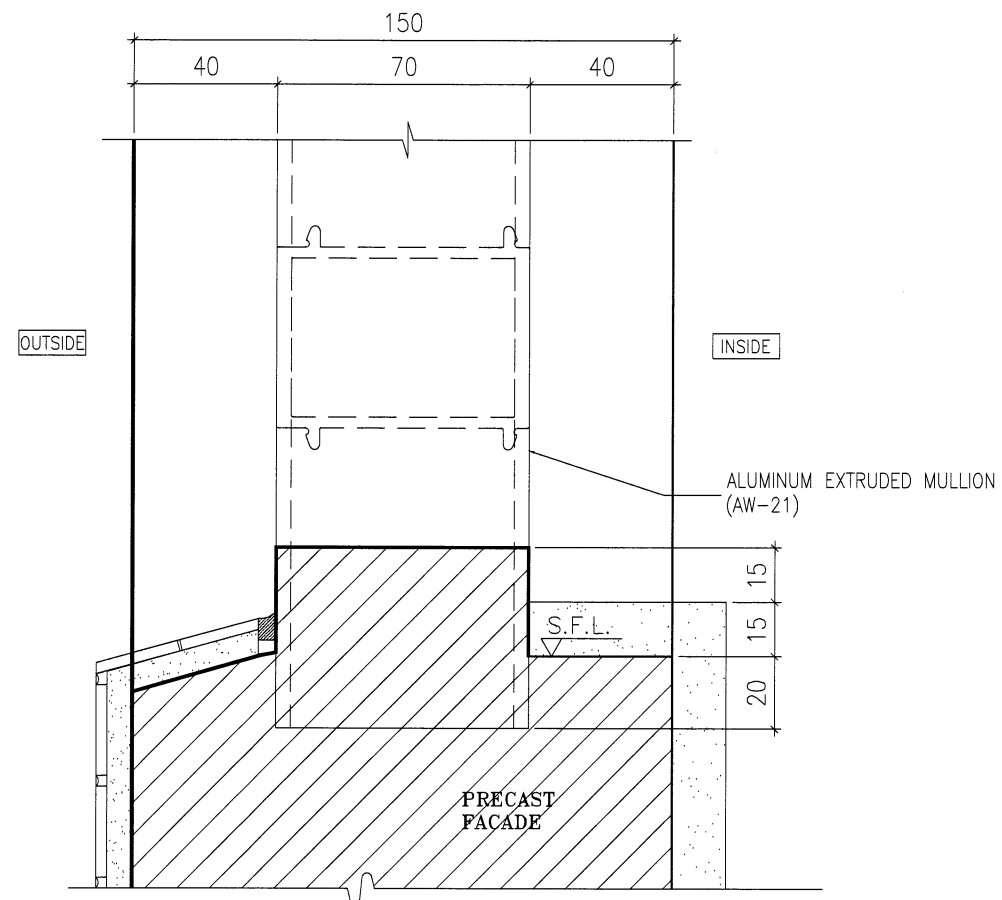

2 HORIZONTAL DETAIL
SCALE 1:2

B.D. REF :

CLIENT :
SUN HUNG KAI
 REAL ESTATE AGENCY LTD.
 42/F SUN HUNG KAI CENTRE, WANCHAI, HONGKONG

ARCHITECT :
Iwk&partners
 architects

MAIN CONTRACTOR :
Yee Fai Building Contractors Ltd.

STRUCTURAL ENGINEER :
ARUP

FACADE CONSULTANT:
ALPHA CONSULTING LIMITED
 Steel Structure & Facade Specialist

NOTE :
 1. ALL DIMENSIONS ARE IN mm.
 2. ALL ELEVATIONS ARE VIEWED FROM OUTSIDE.
 3. ALL DIMENSIONS TO BE VERIFIED ON SITE BEFORE FABRICATION.

LEGEND :
 (X1) --- DETAIL MARK NO.
 (X001) --- REFER SHEET NO.
 1. F.F.L. --- FINISHED FLOOR LEVEL
 2. S.F.L. --- STRUCTURAL FLOOR LEVEL
 3. (R) --- REVERSED DETAIL
 4. GLASS LEGEND
 EGL-1--8mmHS+12mm AIR GAP+10mmTP THK. I.G.U.
 EGL-2--10mm THK. CLEAR TEMPERED GLASS
 EGL-4--10mm THK. TEMPERED ACID ETCHED GLASS
 EGL-1A--8mmHS+12mm AIR GAP+8mmTP THK. I.G.U.

NO.	DATE	REVISED	BY

JOB NO. : J-856

PROJECT :
 PROPOSED DEVELOPMENT ABOVE
 LIGHT RAIL TIN WING STOP, TSWTL
 NO.23, AREA 33, TIN SHUI WAI, N.T.

TITLE :
 TYPICAL DETAILS FOR
 ALUM. WINDOW

DATE : 02-Aug-21 SCALE : 1:40

DRAWN BY : Ivan CHECKED BY :

美特鋁質有限公司
MIDI ALUMINIUM FABRICATOR LTD.
 Units 6-8, Sunray Industrial Centre, 1/F
 610 Cha Kwo Ling Road, Kowloon
 Tel:23489211-4 Fax:(852)27727666

DWG NO. : J856-SD-PW-DT73a REV. : -

70窗

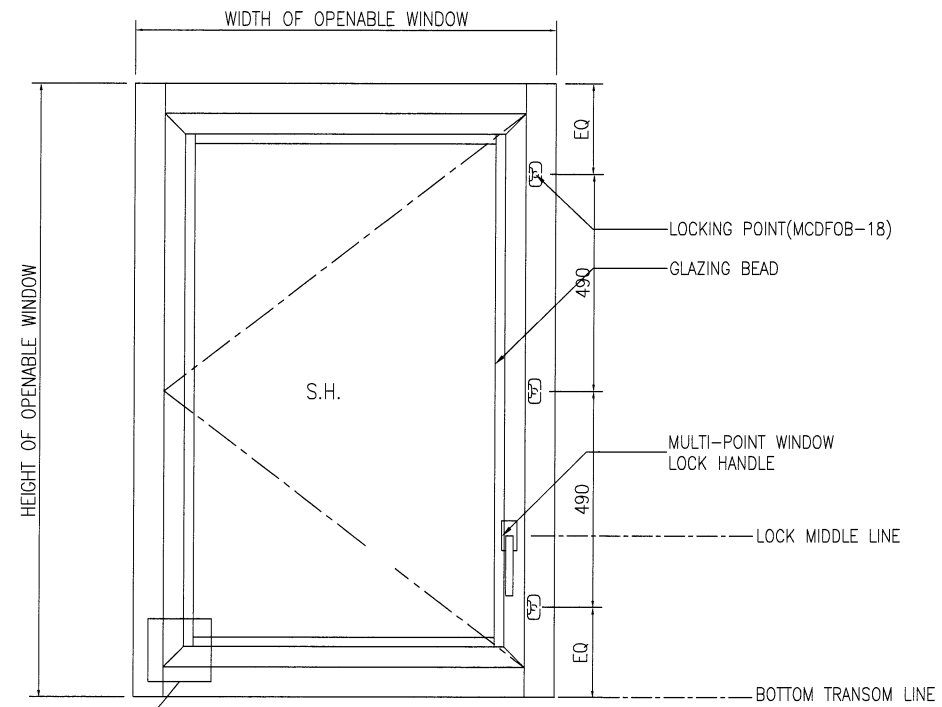
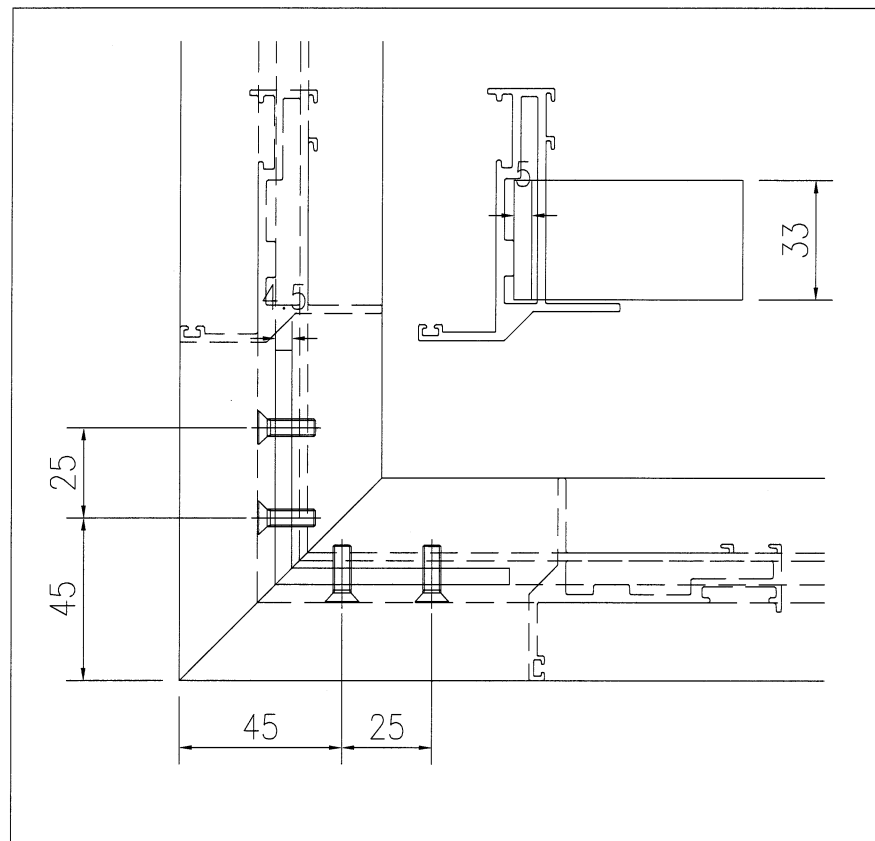

01 TYPICAL SECTION

S.F.L.

B.D. REF :

CLIENT :
SUN HUNG KAI
 REAL ESTATE AGENCY LTD.
 42/F SUN HUNG KAI CENTRE, WANCHAI, HONGKONG

ARCHITECT :
lwk&partners
 architects

MAIN CONTRACTOR :
Yee Fai Building Contractors Ltd.

STRUCTURAL ENGINEER :
ARUP

FACADE CONSULTANT:
ALPHA CONSULTING LIMITED
 Steel Structure & Facade Specialist

NOTE :
 1. ALL DIMENSIONS ARE IN mm.
 2. ALL ELEVATIONS ARE VIEWED FROM OUTSIDE.
 3. ALL DIMENSIONS TO BE VERIFIED ON SITE BEFORE FABRICATION.

LEGEND :
 (X1) — DETAIL MARK NO.
 (X001) — REFER SHEET NO.
 1. F.F.L. — FINISHED FLOOR LEVEL
 2. S.F.L. — STRUCTURAL FLOOR LEVEL
 3. (R) — REVERSED DETAIL
 4. GLASS LEGEND
 EGL-1 — 8mmHS+12mm AIR GAP+10mmTP THK. I.G.U.
 EGL-2 — 10mm THK. CLEAR TEMPERED GLASS
 EGL-4 — 10mm THK. TEMPERED ACID ETCHED GLASS
 EGL-1A — 8mmHS+12mm AIR GAP+8mmTP THK. I.G.U.

NO.	DATE	REVISED	BY

JOB NO. : J-856
 PROJECT : PROPOSED DEVELOPMENT ABOVE LIGHT RAIL TIN WING STOP, TSWTL NO.23, AREA 33, TIN SHUI WAI, N.T.

TITLE : ALUM. WINDOW SECTION
 TYPICAL LOCK & HINGES DETAIL

DATE : 02-Aug-21 SCALE : 1:40

DRAWN BY : Ivan CHECKED BY :

英特鋁質有限公司
MIDI ALUMINIUM FABRICATOR LTD.
 Units 6-8, Sunray Industrial Centre, 1/F
 610 Cha Kwo Ling Road, Kowloon
 Tel:23489211-4 Fax:(852)27727666

DWG NO. : J856-SD-PW-DT74 REV. : -

50窗

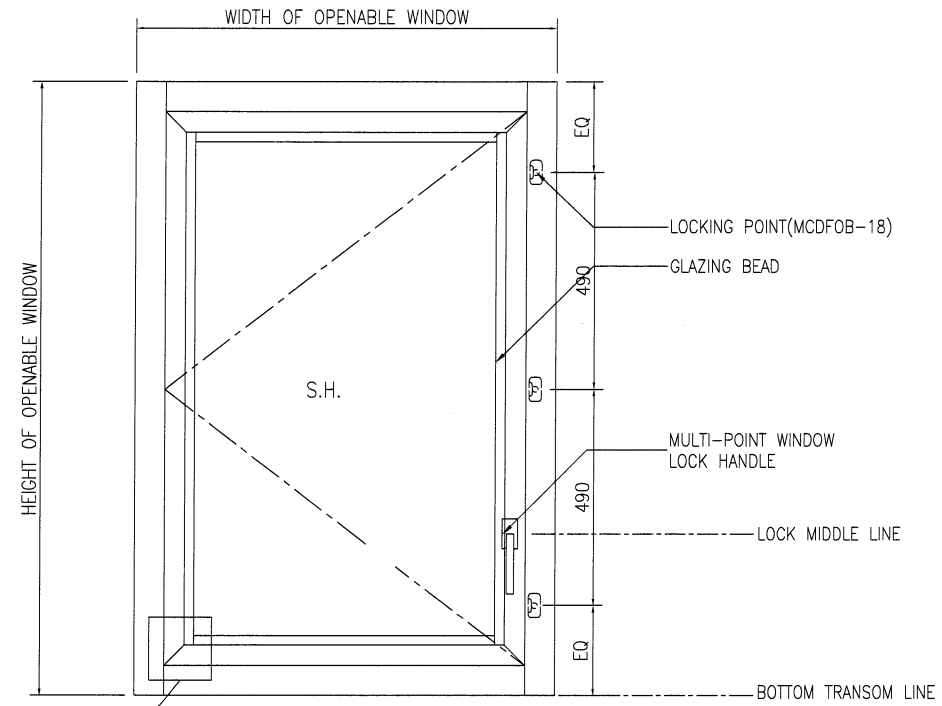
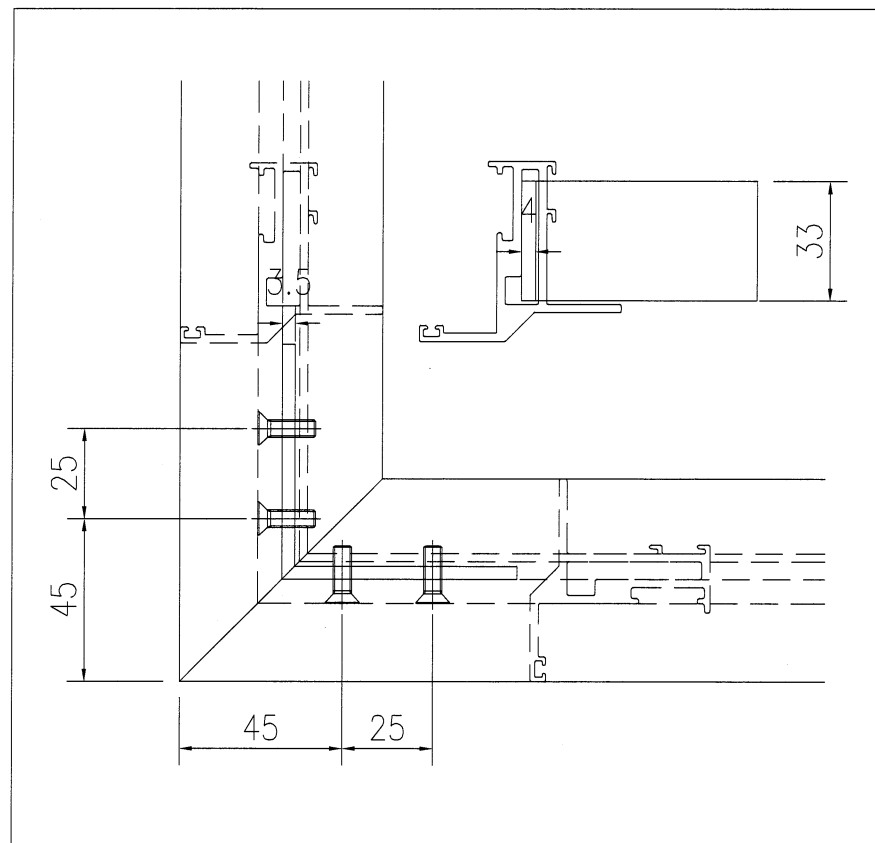

01 TYPICAL SECTION

S.F.L.

B.D. REF :

CLIENT :
SUN HUNG KAI
 REAL ESTATE AGENCY LTD.
 42/F SUN HUNG KAI CENTRE, WANCHAI, HONGKONG

ARCHITECT :
lwk&partners
 architects

MAIN CONTRACTOR :
Yee Fai Building Contractors Ltd.

STRUCTURAL ENGINEER :
ARUP

FACADE CONSULTANT:
ALPHA CONSULTING LIMITED
 Steel Structure & Facade Specialist

NOTE :
 1. ALL DIMENSIONS ARE IN mm.
 2. ALL ELEVATIONS ARE VIEWED FROM OUTSIDE.
 3. ALL DIMENSIONS TO BE VERIFIED ON SITE BEFORE FABRICATION.

LEGEND :
 X1 — DETAIL MARK NO.
 X001 — REFER SHEET NO.
 1. F.F.L. — FINISHED FLOOR LEVEL
 2. S.F.L. — STRUCTURAL FLOOR LEVEL
 3. (R) — REVERSED DETAIL
 4. GLASS LEGEND
 EGL-1 — 8mmHS+12mm AIR GAP+10mmTP THK. I.G.U.
 EGL-2 — 10mm THK. CLEAR TEMPERED GLASS
 EGL-4 — 10mm THK. TEMPERED ACID ETCHED GLASS
 EGL-1A — 8mmHS+12mm AIR GAP+8mmTP THK. I.G.U.

NO.	DATE	REVISED	BY

JOB NO. : J-856
 PROJECT : PROPOSED DEVELOPMENT ABOVE LIGHT RAIL TIN WING STOP, TSWTL NO.23, AREA 33, TIN SHUI WAI, N.T.

TITLE : ALUM. WINDOW SECTION
 TYPICAL LOCK & HINGES DETAIL

DATE : 02-Aug-21 SCALE : 1:40

DRAWN BY : Ivan CHECKED BY :

美特鋁質有限公司
MIDI ALUMINIUM FABRICATOR LTD.
 Units 6-8, Sunray Industrial Centre, 1/F
 610 Cha Kwo Ling Road, Kowloon
 Tel:23489211-4 Fax:(852)27727666

DWG NO. : J856-SD-PW-DT74d REV. : -

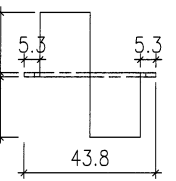
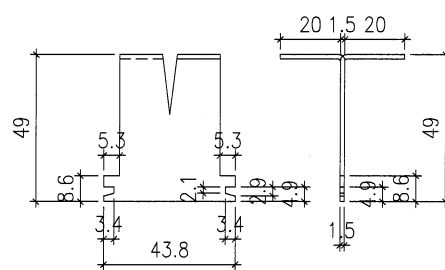
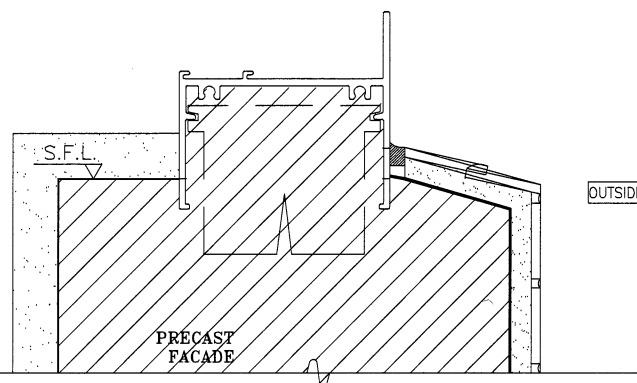
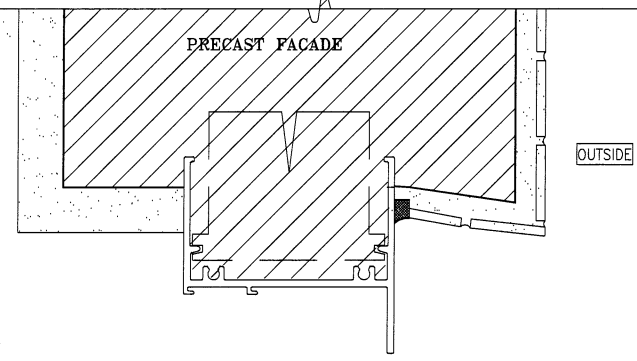
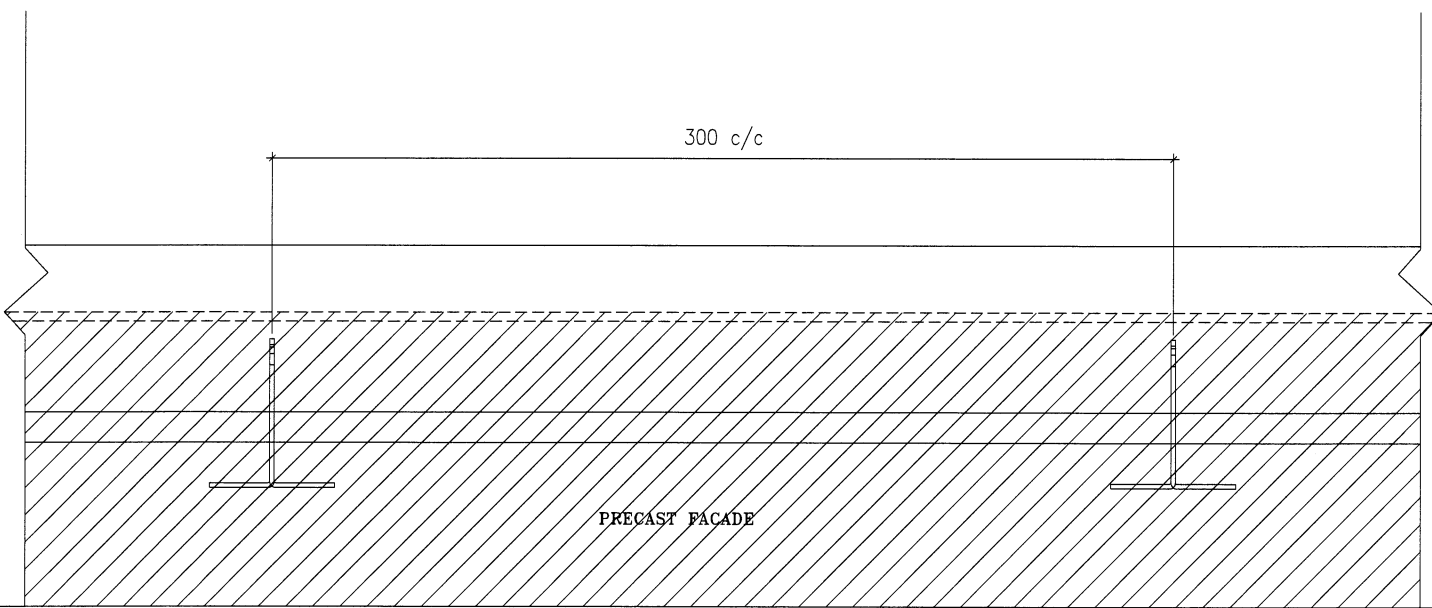
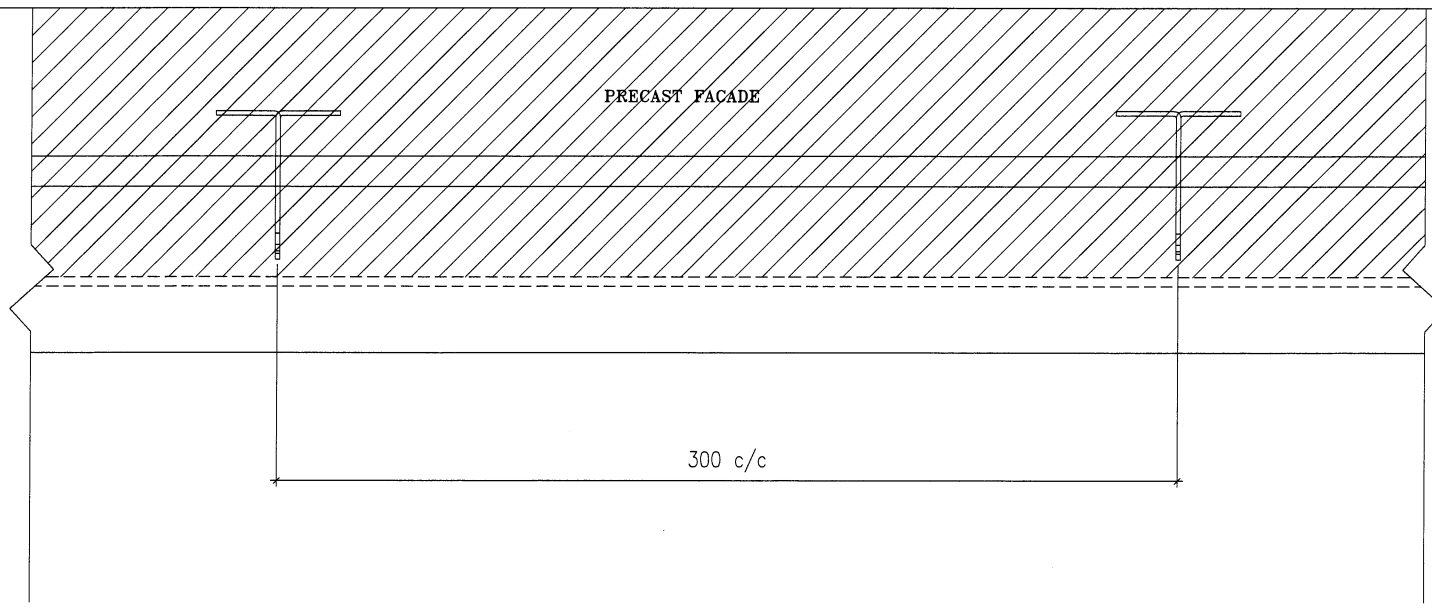

3 HORIZONTAL DETAIL
SCALE 1:2

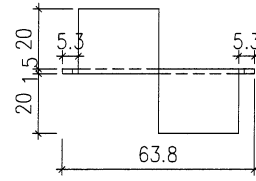
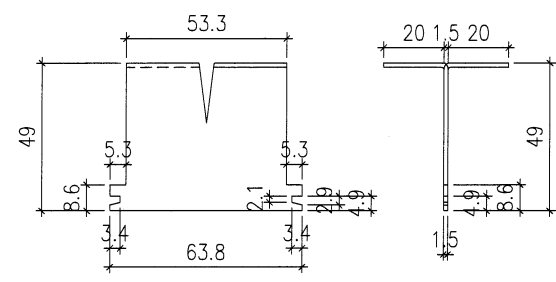

1 HORIZONTAL DETAIL
SCALE 1:2

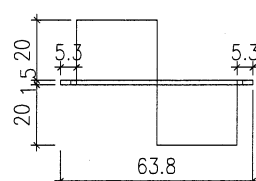
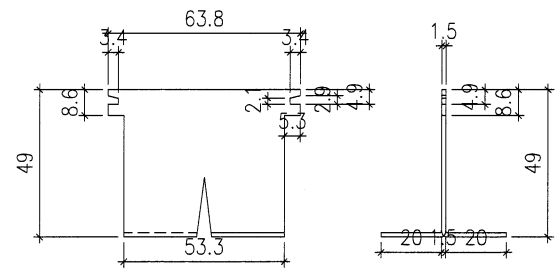

2 HORIZONTAL DETAIL
SCALE 1:2

B.D. REF :
.....

CLIENT :
SUN HUNG KAI
REAL ESTATE AGENCY LTD.
42/F SUN HUNG KAI CENTRE, WANCHAI, HONGKONG

ARCHITECT :
lwk&partners
architects

MAIN CONTRACTOR :
Yee Fai Building Contractors Ltd.

STRUCTURAL ENGINEER :
ARUP

FACADE CONSULTANT:
ALPHA CONSULTING LIMITED
Steel Structure & Facade Specialist

NOTE :
1. ALL DIMENSIONS ARE IN mm.
2. ALL ELEVATIONS ARE VIEWED FROM OUTSIDE.
3. ALL DIMENSIONS TO BE VERIFIED ON SITE BEFORE FABRICATION.

LEGEND :
X1 - DETAIL MARK NO.
X001 - REFER SHEET NO.
1. F.F.L. -- FINISHED FLOOR LEVEL
2. S.F.L. -- STRUCTURAL FLOOR LEVEL
3. (R) -- REVERSED DETAIL
4. GLASS LEGEND
EGL-1--8mmHS+12mm AIR GAP+10mmTP THK. I.G.U.
EGL-2--10mm THK. CLEAR TEMPERED GLASS
EGL-4--10mm THK. TEMPERED ACID ETCHED GLASS
EGL-1A--8mmHS+12mm AIR GAP+8mmTP THK. I.G.U.

NO.	DATE	REVISED	BY

JOB NO. : J-856
PROJECT : PROPOSED DEVELOPMENT ABOVE LIGHT RAIL TIN WING STOP, TSWTL NO.23, AREA 33, TIN SHUI WAI, N.T.

TITLE : G.M.S FIXING LUG TYPICAL DETAIL FOR ALUM. WINDOW

DATE : 02-Aug-21 SCALE : 1:60

DRAWN BY : Ivan CHECKED BY :

美特鋁質有限公司
MIDI ALUMINIUM FABRICATOR LTD.
Units 6-8, Sunray Industrial Centre, 1/F
610 Cha Kwo Ling Road, Kowloon
Tel: 23489211-4 Fax: (852) 2727666

DWG NO. : JB56-SD-PW-DT75 REV. : -

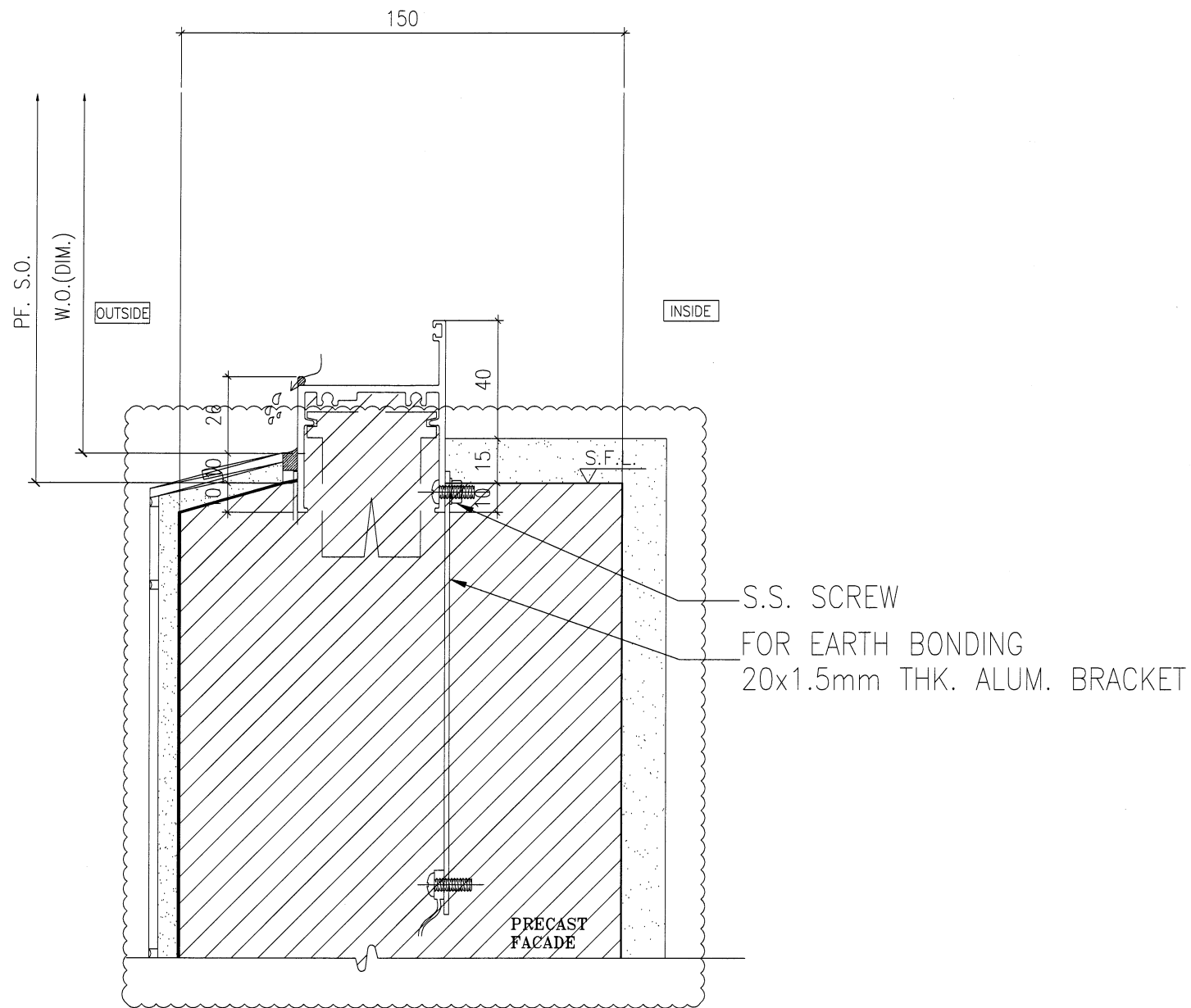

1 HORIZONTAL DETAIL
SCALE 1:2

B.D. REF :

CLIENT :
SUN HUNG KAI
 REAL ESTATE AGENCY LTD.
 42/F SUN HUNG KAI CENTRE, WANCHAI, HONGKONG

ARCHITECT :
lwk&partners
 architects

MAIN CONTRACTOR :
Yee Fai Building Contractors Ltd.

STRUCTURAL ENGINEER :
ARUP

FACADE CONSULTANT:
ALPHA CONSULTING LIMITED
 Steel Structure & Facade Specialist

NOTE :
 1. ALL DIMENSIONS ARE IN mm.
 2. ALL ELEVATIONS ARE VIEWED FROM OUTSIDE.
 3. ALL DIMENSIONS TO BE VERIFIED ON SITE BEFORE FABRICATION.

LEGEND :
 (X1) — DETAIL MARK NO.
 (X001) — REFER SHEET NO.
 1. F.F.L. — FINISHED FLOOR LEVEL
 2. S.F.L. — STRUCTURAL FLOOR LEVEL
 3. (R) — REVERSED DETAIL
 4. GLASS LEGEND
 EGL-1—8mmHS+12mm AIR GAP+10mmTP THK. I.G.U.
 EGL-2—10mm THK. CLEAR TEMPERED GLASS
 EGL-4—10mm THK. TEMPERED ACID ETCHED GLASS
 EGL-1A—8mmHS+12mm AIR GAP+8mmTP THK. I.G.U.

NO.	DATE	REVISION	BY
A	03/01/2022	REVISION SUBJECT TO ARCH.COMMENT	ivan

JOB NO. : J-856
 PROJECT : PROPOSED DEVELOPMENT ABOVE LIGHT RAIL TIN WING STOP, TSWTL NO.23, AREA 33, TIN SHUI WAI, N.T.

TITLE : TYPICAL EARTHING BONDING DETAILS OF PRECAST

DATE : 02-Aug-21 SCALE : 1:40

DRAWN BY : Ivan CHECKED BY :

美特鋁質有限公司
MIDI ALUMINIUM FABRICATOR LTD.
 Units 6-8, Sunray Industrial Centre, 1/F
 610 Cha Kwo Ling Road, Kowloon
 Tel:23489211-4 Fax:(852)27727666

DWG NO. : J856-SD-PW-DT76 REV. : A

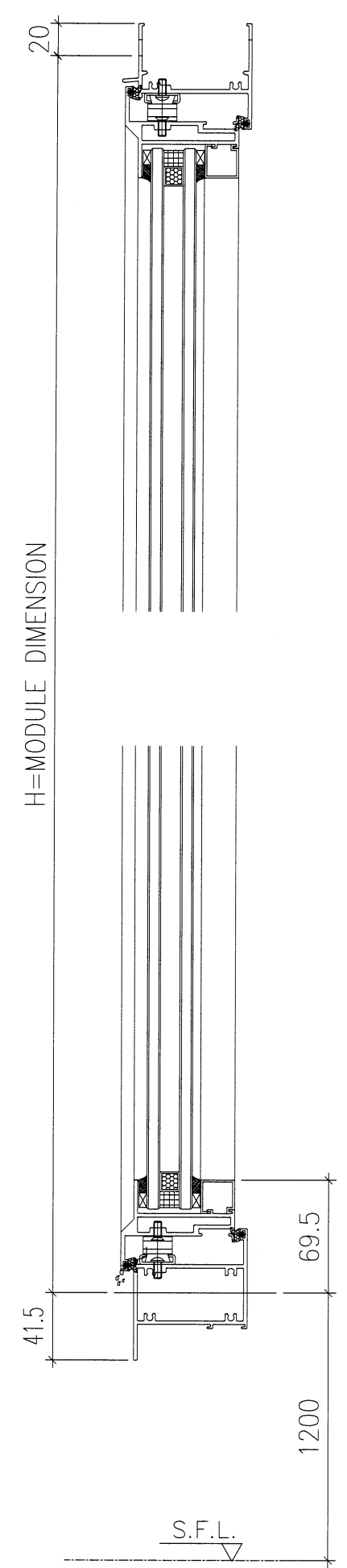
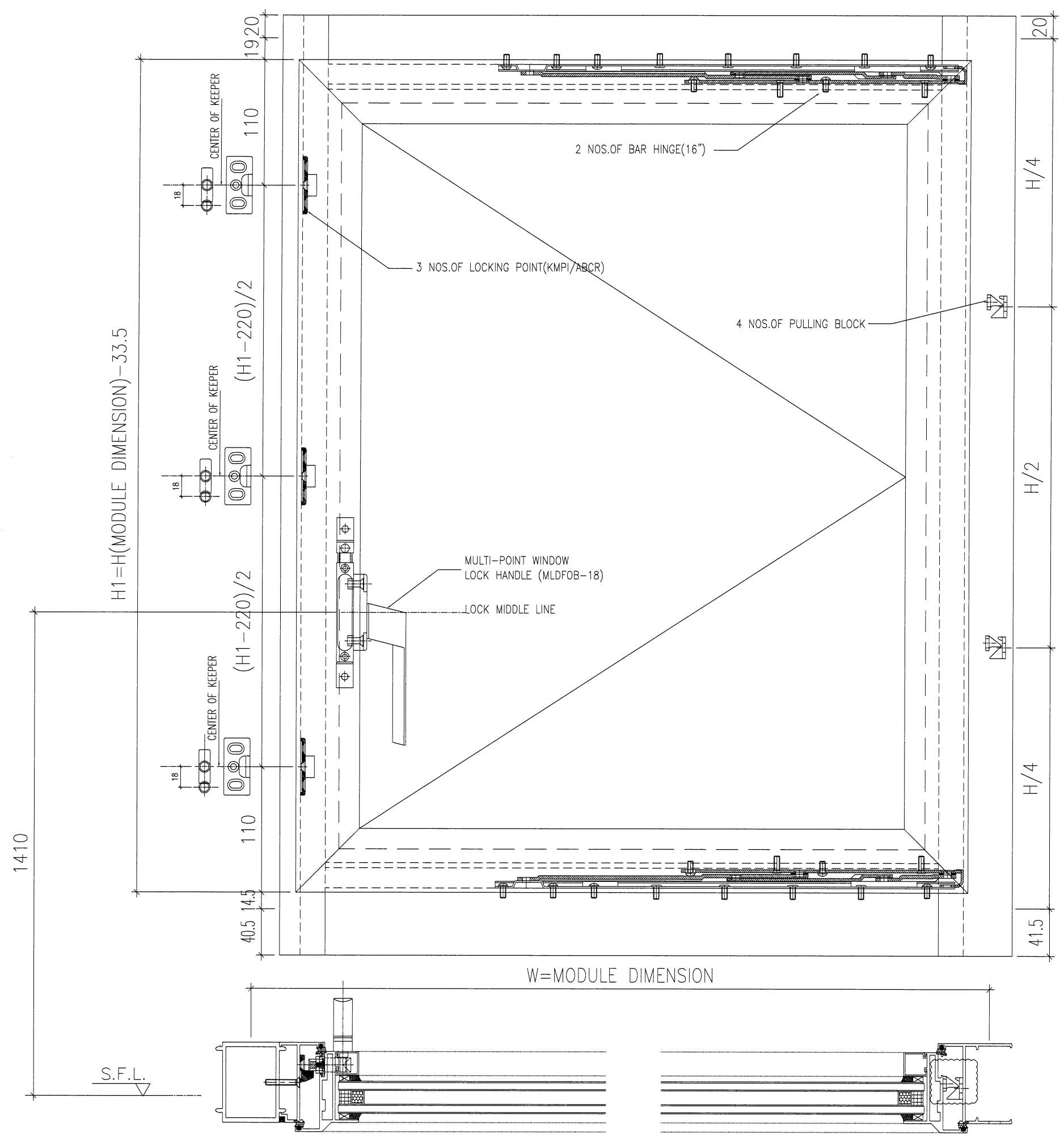

B.D. REF :
 CLIENT :

SUN HUNG KAI
 REAL ESTATE AGENCY LTD.
 42/F SUN HUNG KAI CENTRE, WANCHAI, HONGKONG

ARCHITECT :
lwk&partners
 architects

MAIN CONTRACTOR :
Yee Fai Building Contractors Ltd.

STRUCTURAL ENGINEER :
ARUP

FACADE CONSULTANT:
ALPHA CONSULTING LIMITED
 Steel Structure & Facade Specialist

NOTE :
 1. ALL DIMENSIONS ARE IN mm.
 2. ALL ELEVATIONS ARE VIEWED FROM OUTSIDE.
 3. ALL DIMENSIONS TO BE VERIFIED ON SITE BEFORE FABRICATION.

LEGEND :
 (X1) — DETAIL MARK NO.
 (X001) — REFER SHEET NO.
 1. F.F.L. — FINISHED FLOOR LEVEL
 2. S.F.L. — STRUCTURAL FLOOR LEVEL
 3. (R) — REVERSED DETAIL
 4. GLASS LEGEND
 EGL-1 — 8mmHS+12mm AIR GAP+10mmTP THK. I.G.U.
 EGL-2 — 10mm THK. CLEAR TEMPERED GLASS
 EGL-4 — 10mm THK. TEMPERED ACID ETCHED GLASS
 EGL-1A — 8mmHS+12mm AIR GAP+8mmTP THK. I.G.U.

NO.	DATE	REVISION	BY
A	03/01/2022	REVISION SUBJECT TO ARCH.COMMENT	Ivan

JOB NO. : J-856
 PROJECT :
 PROPOSED DEVELOPMENT ABOVE
 LIGHT RAIL TIN WING STOP, TSWTL
 NO.23, AREA 33, TIN SHUI WAI, N.T.

TITLE :
 TYPICAL EARTHING
 BONDING DETAILS OF PRECAST

DATE : 02-Aug-21 SCALE : 1:60

DRAWN BY : Ivan CHECKED BY :

美特鋁質有限公司
MIDI ALUMINUM FABRICATOR LTD.
 Units 6-8, Sunray Industrial Centre, 1/F
 610 Cha Kwo Ling Road, Kowloon
 Tel:23489211-4 Fax:(852)27727666

DWG NO. : J856-SD-PW-DT77 REV. : A

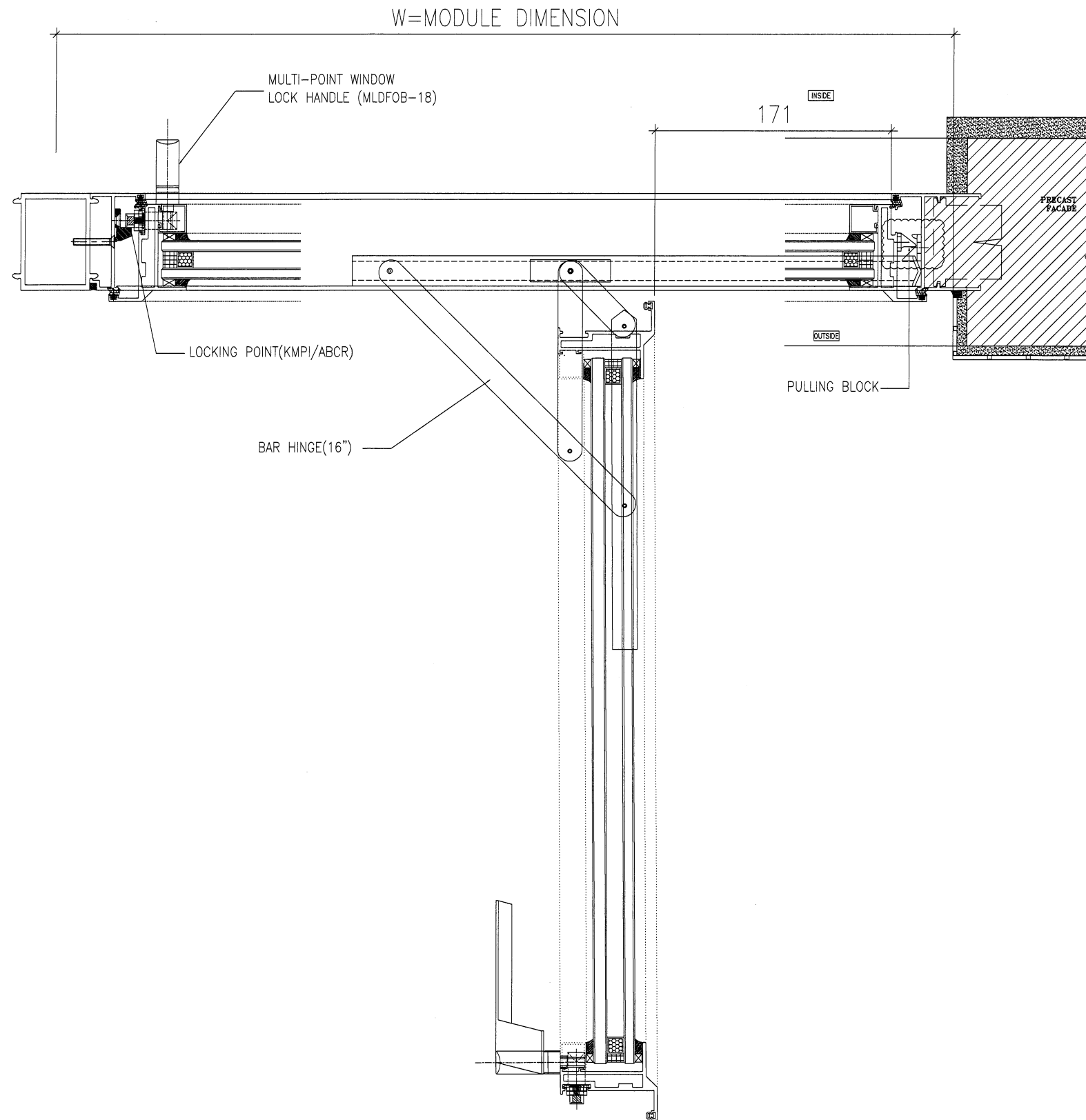

B.D. REF :

CLIENT :
SUN HUNG KAI
 REAL ESTATE AGENCY LTD.
 42/F SUN HUNG KAI CENTRE, WANCHAI, HONGKONG

ARCHITECT :
lwk&partners
 architects

MAIN CONTRACTOR :
Yee Fai Building Contractors Ltd.

STRUCTURAL ENGINEER :
ARUP

FACADE CONSULTANT:
ALPHA CONSULTING LIMITED
 Steel Structure & Facade Specialist

NOTE :
 1. ALL DIMENSIONS ARE IN mm.
 2. ALL ELEVATIONS ARE VIEWED FROM OUTSIDE.
 3. ALL DIMENSIONS TO BE VERIFIED ON SITE BEFORE FABRICATION.

LEGEND :
 X1 — DETAIL MARK NO.
 X001 — REFER SHEET NO.
 1. F.F.L. — FINISHED FLOOR LEVEL
 2. S.F.L. — STRUCTURAL FLOOR LEVEL
 3. (R) — REVERSED DETAIL
 4. GLASS LEGEND
 EGL-1 — 8mmHS+12mm AIR GAP+10mmTP THK. I.G.U.
 EGL-2 — 10mm THK. CLEAR TEMPERED GLASS
 EGL-4 — 10mm THK. TEMPERED ACID ETCHED GLASS
 EGL-1A — 8mmHS+12mm AIR GAP+8mmTP THK. I.G.U.

NO.	DATE	REVISION	REVISOR	BY
A	03/01/2022	REVISION SUBJECT TO ARCH.COMMENT		Ivan

JOB NO. : J-856
 PROJECT : PROPOSED DEVELOPMENT ABOVE LIGHT RAIL TIN WING STOP, TSWTL NO.23, AREA 33, TIN SHUI WAI, N.T.

TITLE : TYPICAL EARTHING BONDING DETAILS OF PRECAST

DATE : 02-Aug-21 SCALE : 1:60
 DRAWN BY : Ivan CHECKED BY :

英特鋁質有限公司
MIDI ALUMINIUM FABRICATOR LTD.
 Units 6-8, Sunray Industrial Centre, 1/F
 610 Cha Kwo Ling Road, Kowloon
 Tel:23489211-4 Fax:(852)2727666

DWG NO. : J856-SD-PW-DT78 REV. : A