

工程指示 / 要求簡箋(E.I.)

工程指示編號：EI/3986/21

修改版次：-

工程編號：J-856

工程名稱：天水圍天榮站

工程項目：佛沙窗 大圖(3rd submission)

收件人：生統 / 王良

發件人：Eric Liu

日期：03/11/2021

要求提供 / 確認 事項：

- |                                    |                                     |                               |
|------------------------------------|-------------------------------------|-------------------------------|
| <input type="checkbox"/> 初步鋁料 B.M. | <input type="checkbox"/> 加工拆圖，然後生產  | <input type="checkbox"/> 尺寸表  |
| <input type="checkbox"/> 正式鋁料 B.M. | <input type="checkbox"/> 技術上資料 / 指示 | <input type="checkbox"/> 報價   |
| <input type="checkbox"/> 配件 B.M.   | <input type="checkbox"/> 樣辦或貨品說明書   | <input type="checkbox"/> 分判合約 |

內容：

請查閱附件提供佛沙窗大圖 (3rd submission) 只有T3, T1及T2待修改

王良：請安排提供本項目使用的保護方案

謝謝

請在 2021.11.8 前完成上列要求。

附：34 頁 + CAD

以上項目為：

- 原合約工程包                       原合約工程加 / 減賬                       新工程報價

原因：-

分發東莞各部門：

- ( ) 生產技術總監  連附件    ( ) 技術部  連附件    ( ) 生產部  連附件    ( ) 機械設計部  連附件  
 ( ) 採購部  連附件    ( ) 生產統籌部  連附件    ( ) 小羅&清  連附件  
 ( ) 質檢部  連附件    ( ) 會計部  連附件    ( ) 報關組  連附件    ( ) 其他 \_\_\_\_\_  連附件  
 分發其他分判：張  
 (v) 水洪  連附件

分發香港各部門：

- ( ) 行政部  連附件    ( ) 會計部  連附件    ( ) 統籌部  連附件    ( ) 工程部地盤科文  連附件  
 ( ) 採購部  連附件    ( ) QS 部  連附件    ( ) 維修部  連附件    ( ) 其他 \_\_\_\_\_  連附件

傳遞編號：

HK2001/21

發件人簽署：

項目經理簽署：

PROJECT :

PROPOSED DEVELOPMENT ABOVE  
LIGHT RAIL TIN WING STOP, TSWTL  
NO.23, AREA 33, TIN SHUI WAI, N.T.

5

SHOP DRAWING FOR ALUM. PRECAST WINDOW OF TOWER

DATE: 02-Nov-21



Units 6-8, Sunray Industrial Centre, 1/F  
610 Cha Kwo Ling Road, Kowloon  
Tel:23489211-4 Fax:(852)27727666

# DRAWING SUBMISSION REGISTER

PROJECT: PROPOSED DEVELOPMENT ABOVE LIGHT RAIL TIN WING STOP TSWTL NO.23, AREA 33, TIN SHUI WAI, N.T. TITLE: ALUM. WINDOW OF TOWER SHOPDRAWING SUBMISSION		DATE OF ISSUE					SUBMISSION STATE (FOR B.D./A.S.D)			SUBMISSION STATE (FOR CLIENT / CONSULTANT)			SUBMISSION STATE (FOR ARCHITECT)			FABRICATION / CONSTRUCTION STATE				
		ISSUE	1	2	3	4	5	AP - APPROVED	AC - APPROVED SUB. TO CONDITION	NA - NOT APPROVED	AP - APPROVED	AC - APPROVED SUB. TO CONDITION	NA - NOT APPROVED	AP - APPROVED	AC - APPROVED SUB. TO CONDITION	NA - NOT APPROVED	ISSUE TO CHINA OFFICE	ISSUE TO SITE	ISSUE TO SUB-CONTRACTOR	
		DAY	22	12	18	30	2	MONTH	9	10	10	10	11	YEAR	21	21	21	21	21	21
DRAWING TITLE	DWG. NO.	REVISIONS																		
COVER PAGE	J856-SD-PW-0000	-	A	B	C	D														
DRAWING REGISTER	J856-SD-PW-0001	-	A			B														
DRAWING REGISTER	J856-SD-PW-0002	-	A																	
DRAWING REGISTER	J856-SD-PW-0003	-	A	B		C														
DRAWING REGISTER	J856-SD-PW-0004	-	A	B																
DRAWING REGISTER	J856-SD-PW-0005	-	A	B		C														
GENERAL NOTES FOR ALUM. WINDOW	J856-SD-PW-GN01	-	-																	
EXTRUSION LIST FOR ALUM. WINDOW	J856-SD-PW-1101	-	A	A	A	B														
EXTRUSION LIST FOR ALUM. WINDOW	J856-SD-PW-1102	-	-	A	B	C														
PLAN FOR ALUM. WINDOW AT TOWER 1(3/F)	J856-SD-PW-3101	-	-																	
PLAN FOR ALUM. WINDOW AT TOWER 1(5/F-4/2F)	J856-SD-PW-3102	-	A																	
PLAN FOR ALUM. WINDOW AT TOWER 1(4/3F)	J856-SD-PW-3103	-	-																	
PLAN FOR ALUM. WINDOW AT TOWER 1(4/5F)	J856-SD-PW-3104	-	-																	
PLAN FOR ALUM. WINDOW AT TOWER 1(4/6F)	J856-SD-PW-3105	-	-																	
PLAN FOR ALUM. WINDOW AT TOWER 2(3/F)	J856-SD-PW-3201	-	-																	
PLAN FOR ALUM. WINDOW AT TOWER 2(3/F-4/2F)	J856-SD-PW-3202	-	A																	
PLAN FOR ALUM. WINDOW AT TOWER 2(4/3F)	J856-SD-PW-3203	-	-																	
PLAN FOR ALUM. WINDOW AT TOWER 2(4/5F)	J856-SD-PW-3204	-	-																	
PLAN FOR ALUM. WINDOW AT TOWER 2(4/6F)	J856-SD-PW-3205	-	-																	
PLAN FOR ALUM. WINDOW AT TOWER 3(3/F)	J856-SD-PW-3301	-	-																	
PLAN FOR ALUM. WINDOW AT TOWER 3(3/F)	J856-SD-PW-3302	-	A	B	C	D														
PLAN FOR ALUM. WINDOW AT TOWER 3(4/3F)	J856-SD-PW-3303	-	-																	
PLAN FOR ALUM. WINDOW AT TOWER 3(4/5F)	J856-SD-PW-3304	-	-																	
PLAN FOR ALUM. WINDOW AT TOWER 3(4/6F)	J856-SD-PW-3305	-	-																	
WINDOW SCHEDULE FOR TOWER 1 ALUM. WINDOW	J856-SD-PW-5101	-	A																	
WINDOW SCHEDULE FOR TOWER 1 ALUM. WINDOW	J856-SD-PW-5102	-	-																	
WINDOW SCHEDULE FOR TOWER 1 ALUM. WINDOW	J856-SD-PW-5103	-	-																	
WINDOW SCHEDULE FOR TOWER 1 ALUM. WINDOW	J856-SD-PW-5104	-	A																	
WINDOW SCHEDULE FOR TOWER 1 ALUM. WINDOW	J856-SD-PW-5105	-	-																	
WINDOW SCHEDULE FOR TOWER 1 ALUM. WINDOW	J856-SD-PW-5106	-	A																	
WINDOW SCHEDULE FOR TOWER 1 ALUM. WINDOW	J856-SD-PW-5107	-	-																	
WINDOW SCHEDULE FOR TOWER 1 ALUM. WINDOW	J856-SD-PW-5108	-	-																	
WINDOW SCHEDULE FOR TOWER 1 ALUM. WINDOW	J856-SD-PW-5109	-	A																	
WINDOW SCHEDULE FOR TOWER 1 ALUM. WINDOW	J856-SD-PW-5110	-	A																	
WINDOW SCHEDULE FOR TOWER 1 ALUM. WINDOW	J856-SD-PW-5111	-	A																	
WINDOW SCHEDULE FOR TOWER 1 ALUM. WINDOW	J856-SD-PW-5112	-	A																	
WINDOW SCHEDULE FOR TOWER 1 ALUM. WINDOW	J856-SD-PW-5113	-	A																	
WINDOW SCHEDULE FOR TOWER 1 ALUM. WINDOW	J856-SD-PW-5114	-	A																	
WINDOW SCHEDULE FOR TOWER 1 ALUM. WINDOW	J856-SD-PW-5115	-	-																	
WINDOW SCHEDULE FOR TOWER 1 ALUM. WINDOW	J856-SD-PW-5116	-	-																	
WINDOW SCHEDULE FOR TOWER 1 ALUM. WINDOW	J856-SD-PW-5117	-	A																	
WINDOW SCHEDULE FOR TOWER 1 ALUM. WINDOW	J856-SD-PW-5118	-	A																	

IN-HOUSE DESIGN CHECKER

**美特鋁質有限公司**  
MIDI ALUMINIUM FABRICATOR LTD.  
Units 6-8, Sunny Industrial Centre, 1/F  
610 Cho Kwo Ling Road, Kowloon  
Tel: 23489211-4 Fax: (852) 27272666  
DWG NO. : J852-SD-PW-0001 REV. : B

# DRAWING SUBMISSION REGISTER

PROJECT: PROPOSED DEVELOPMENT ABOVE LIGHT RAIL TIN WING STOP, TSWTL NO.23, AREA 33, TIN SHUI WAI, N.T.  TITLE: ALUM. WINDOW OF TOWER SHOPDRAWING SUBMISSION	DATE OF ISSUE					SUBMISSION STATE (FOR B.D./A.S.D)			SUBMISSION STATE (FOR CLIENT / CONSULTANT)			SUBMISSION STATE (FOR ARCHITECT)			FABRICATION / CONSTRUCTION STATE										
	ISSUE	1	2	3	4	5	AP - APPROVED			AP - APPROVED			AP - APPROVED			ISSUE TO CHINA OFFICE		ISSUE TO SITE		ISSUE TO SUB-CONTRACTOR					
	DAY	22	12	18	30	2	AC - APPROVED SUB. TO CONDITION			AC - APPROVED SUB. TO CONDITION			AC - APPROVED SUB. TO CONDITION												
	MONTH	9	10	10	10	11	NA - NOT APPROVED			NA - NOT APPROVED			NA - NOT APPROVED												
YEAR	21	21	21	21	21	REVISIONS																			
DWG. NO.											COMMENT DATE	REV.	STATE	COMMENT DATE	REV.	STATE	COMMENT DATE	REV.	STATE	REV.	DATE	REV.	DATE	REV.	DATE
WINDOW SCHEDULE FOR TOWER 1 ALUM. WINDOW	J856-SD-PW-5119	-	A																						
WINDOW SCHEDULE FOR TOWER 1 ALUM. WINDOW	J856-SD-PW-5120	-	A																						
WINDOW SCHEDULE FOR TOWER 1 ALUM. WINDOW	J856-SD-PW-5121	-	A																						
WINDOW SCHEDULE FOR TOWER 1 ALUM. WINDOW	J856-SD-PW-5122	-	A																						
WINDOW SCHEDULE FOR TOWER 1 ALUM. WINDOW	J856-SD-PW-5123	-	-																						
WINDOW SCHEDULE FOR TOWER 1 ALUM. WINDOW	J856-SD-PW-5124	-	-																						
WINDOW SCHEDULE FOR TOWER 1 ALUM. WINDOW	J856-SD-PW-5125	-	A																						
WINDOW SCHEDULE FOR TOWER 1 ALUM. WINDOW	J856-SD-PW-5126	-	A																						
WINDOW SCHEDULE FOR TOWER 1 ALUM. WINDOW	J856-SD-PW-5127	-	-																						
WINDOW SCHEDULE FOR TOWER 1 ALUM. WINDOW	J856-SD-PW-5128	-	-																						
WINDOW SCHEDULE FOR TOWER 1 ALUM. WINDOW	J856-SD-PW-5129	-	-																						
WINDOW SCHEDULE FOR TOWER 1 ALUM. WINDOW	J856-SD-PW-5130	-	-																						
WINDOW SCHEDULE FOR TOWER 1 ALUM. WINDOW	J856-SD-PW-5131	-	-																						
WINDOW SCHEDULE FOR TOWER 1 ALUM. WINDOW	J856-SD-PW-5132	-	-																						
WINDOW SCHEDULE FOR TOWER 1 ALUM. WINDOW	J856-SD-PW-5133	-	-																						
WINDOW SCHEDULE FOR TOWER 1 ALUM. WINDOW	J856-SD-PW-5134	-	-																						
WINDOW SCHEDULE FOR TOWER 1 ALUM. WINDOW	J856-SD-PW-5135	-	-																						
WINDOW SCHEDULE FOR TOWER 1 ALUM. WINDOW	J856-SD-PW-5136	-	-																						
WINDOW SCHEDULE FOR TOWER 1 ALUM. WINDOW	J856-SD-PW-5137	-	-																						
WINDOW SCHEDULE FOR TOWER 1 ALUM. WINDOW	J856-SD-PW-5138	-	-																						
WINDOW SCHEDULE FOR TOWER 1 ALUM. WINDOW	J856-SD-PW-5139	-	-																						
WINDOW SCHEDULE FOR TOWER 1 ALUM. WINDOW	J856-SD-PW-5140	-	-																						
WINDOW SCHEDULE FOR TOWER 1 ALUM. WINDOW	J856-SD-PW-5141	-	-																						
WINDOW SCHEDULE FOR TOWER 1 ALUM. WINDOW	J856-SD-PW-5142	-	-																						
WINDOW SCHEDULE FOR TOWER 1 ALUM. WINDOW	J856-SD-PW-5143	-	-																						
WINDOW SCHEDULE FOR TOWER 1 ALUM. WINDOW	J856-SD-PW-5144	-	-																						
WINDOW SCHEDULE FOR TOWER 1 ALUM. WINDOW	J856-SD-PW-5145	-	-																						
WINDOW SCHEDULE FOR TOWER 2 ALUM. WINDOW	J856-SD-PW-5201	-	A																						
WINDOW SCHEDULE FOR TOWER 2 ALUM. WINDOW	J856-SD-PW-5202	-	-																						
WINDOW SCHEDULE FOR TOWER 2 ALUM. WINDOW	J856-SD-PW-5203	-	-																						
WINDOW SCHEDULE FOR TOWER 2 ALUM. WINDOW	J856-SD-PW-5204	-	A																						
WINDOW SCHEDULE FOR TOWER 2 ALUM. WINDOW	J856-SD-PW-5205	-	-																						
WINDOW SCHEDULE FOR TOWER 2 ALUM. WINDOW	J856-SD-PW-5206	-	A																						
WINDOW SCHEDULE FOR TOWER 2 ALUM. WINDOW	J856-SD-PW-5207	-	-																						
WINDOW SCHEDULE FOR TOWER 2 ALUM. WINDOW	J856-SD-PW-5208	-	-																						
WINDOW SCHEDULE FOR TOWER 2 ALUM. WINDOW	J856-SD-PW-5209	-	A																						
WINDOW SCHEDULE FOR TOWER 2 ALUM. WINDOW	J856-SD-PW-5210	-	A																						
WINDOW SCHEDULE FOR TOWER 2 ALUM. WINDOW	J856-SD-PW-5211	-	A																						
WINDOW SCHEDULE FOR TOWER 2 ALUM. WINDOW	J856-SD-PW-5211a	/	-																						
WINDOW SCHEDULE FOR TOWER 2 ALUM. WINDOW	J856-SD-PW-5212	-	-																						
WINDOW SCHEDULE FOR TOWER 2 ALUM. WINDOW	J856-SD-PW-5213	-	-																						
WINDOW SCHEDULE FOR TOWER 2 ALUM. WINDOW	J856-SD-PW-5214	-	A																						
WINDOW SCHEDULE FOR TOWER 2 ALUM. WINDOW	J856-SD-PW-5215	-	A																						

IN-HOUSE DESIGN CHECKER



# DRAWING SUBMISSION REGISTER

**PROJECT:**  
**PROPOSED DEVELOPMENT ABOVE**  
**LIGHT RAIL TIN WING STOP TSWTL**  
**NO.23, AREA 33, TIN SHUI WAI, N. T.**  
**TITLE:**  
**ALUM. WINDOW OF TOWER**  
**SHOPDRAWING SUBMISSION**

ISSUE	DATE OF ISSUE					SUBMISSION STATE (FOR B.D / A.S.D)	SUBMISSION STATE (FOR CLIENT / CONSULTANT)	SUBMISSION STATE (FOR ARCHITECT)	FABRICATION / CONSTRUCTION STATE					
	DAY	12	18	18	30				AC - APPROVED SUB. TO CONDITION NA - NOT APPROVED	AC - APPROVED SUB. TO CONDITION NA - NOT APPROVED	AC - APPROVED SUB. TO CONDITION NA - NOT APPROVED	ISSUE TO CHINA OFFICE	ISSUE TO SITE	ISSUE TO SUB-CONTRACTOR
	MONTH	9	10	10	10									
	YEAR	21	21	21	21									

DRAWING TITLE	DWG. NO.	REVISIONS					COMMENT DATE	REV.	STATE	COMMENT DATE	REV.	STATE	COMMENT DATE	REV.	STATE	REV.	DATE	REV.	DATE	REV.	DATE
		1	2	3	4	5															
WINDOW SCHEDULE FOR TOWER 3 ALUM. WINDOW	J856-SD-PW-5316	-	-	A																	
WINDOW SCHEDULE FOR TOWER 3 ALUM. WINDOW	J856-SD-PW-5317	-	A	B																	
WINDOW SCHEDULE FOR TOWER 3 ALUM. WINDOW	J856-SD-PW-5318	-	-	A																	
WINDOW SCHEDULE FOR TOWER 3 ALUM. WINDOW	J856-SD-PW-5319	-	-	A																	
WINDOW SCHEDULE FOR TOWER 3 ALUM. WINDOW	J856-SD-PW-5320	-	A	B																	
WINDOW SCHEDULE FOR TOWER 3 ALUM. WINDOW	J856-SD-PW-5321	-	A	B																	
WINDOW SCHEDULE FOR TOWER 3 ALUM. WINDOW	J856-SD-PW-5322	-	-	A																	
WINDOW SCHEDULE FOR TOWER 3 ALUM. WINDOW	J856-SD-PW-5323	-	-	A																	
WINDOW SCHEDULE FOR TOWER 3 ALUM. WINDOW	J856-SD-PW-5324	-	A	B																	
WINDOW SCHEDULE FOR TOWER 3 ALUM. WINDOW	J856-SD-PW-5325	-	-	A																	
WINDOW SCHEDULE FOR TOWER 3 ALUM. WINDOW	J856-SD-PW-5326	-	-	A																	
WINDOW SCHEDULE FOR TOWER 3 ALUM. WINDOW	J856-SD-PW-5327	-	A	B																	
WINDOW SCHEDULE FOR TOWER 3 ALUM. WINDOW	J856-SD-PW-5328	-	A	B																	
WINDOW SCHEDULE FOR TOWER 3 ALUM. WINDOW	J856-SD-PW-5329	-	-	A																	
WINDOW SCHEDULE FOR TOWER 3 ALUM. WINDOW	J856-SD-PW-5330	-	A	B																	
WINDOW SCHEDULE FOR TOWER 3 ALUM. WINDOW	J856-SD-PW-5331	-	A	B																	
WINDOW SCHEDULE FOR TOWER 3 ALUM. WINDOW	J856-SD-PW-5332	-	A	B																	
WINDOW SCHEDULE FOR TOWER 3 ALUM. WINDOW	J856-SD-PW-5333	-	A	B																	
WINDOW SCHEDULE FOR TOWER 3 ALUM. WINDOW	J856-SD-PW-5334	-	A	B																	
WINDOW SCHEDULE FOR TOWER 3 ALUM. WINDOW	J856-SD-PW-5335	-	A	B																	
WINDOW SCHEDULE FOR TOWER 3 ALUM. WINDOW	J856-SD-PW-5336	-	-	A																	
WINDOW SCHEDULE FOR TOWER 3 ALUM. WINDOW	J856-SD-PW-5337	-	-	A																	
WINDOW SCHEDULE FOR TOWER 3 ALUM. WINDOW	J856-SD-PW-5338	-	-	A																	
WINDOW SCHEDULE FOR TOWER 3 ALUM. WINDOW	J856-SD-PW-5339	-	-	A																	
WINDOW SCHEDULE FOR TOWER 3 ALUM. WINDOW	J856-SD-PW-5340	-	-	A																	
WINDOW SCHEDULE FOR TOWER 3 ALUM. WINDOW	J856-SD-PW-5341	-	-																		
WINDOW SCHEDULE FOR TOWER 3 ALUM. WINDOW	J856-SD-PW-5342	-	-																		
WINDOW SCHEDULE FOR TOWER 3 ALUM. WINDOW	J856-SD-PW-5343	-	-																		
WINDOW SCHEDULE FOR TOWER 3 ALUM. WINDOW	J856-SD-PW-5344	-	-																		
WINDOW SCHEDULE FOR TOWER 3 ALUM. WINDOW	J856-SD-PW-5345	-	-																		
WINDOW SCHEDULE FOR TOWER 3 ALUM. WINDOW	J856-SD-PW-5346	-	-																		
WINDOW SCHEDULE FOR TOWER 3 ALUM. WINDOW	J856-SD-PW-5347	-	-																		
WINDOW SCHEDULE FOR TOWER 3 ALUM. WINDOW	J856-SD-PW-5348	-	-																		
WINDOW SCHEDULE FOR TOWER 3 ALUM. WINDOW	J856-SD-PW-5349	-	-																		
WINDOW SCHEDULE FOR TOWER 3 ALUM. WINDOW	J856-SD-PW-5350	-	-																		
WINDOW SCHEDULE FOR TOWER 3 ALUM. WINDOW	J856-SD-PW-5351	-	-																		
WINDOW SCHEDULE FOR TOWER 3 ALUM. WINDOW	J856-SD-PW-5352	-	-																		
WINDOW SCHEDULE FOR TOWER 3 ALUM. WINDOW	J856-SD-PW-5353	-	-																		
WINDOW SCHEDULE FOR TOWER 3 ALUM. WINDOW	J856-SD-PW-5354	-	-																		
WINDOW SCHEDULE FOR TOWER 3 ALUM. WINDOW	J856-SD-PW-5355	-	-																		
WINDOW SCHEDULE FOR TOWER 3 ALUM. WINDOW	J856-SD-PW-5356	-	-																		
WINDOW SCHEDULE FOR TOWER 3 ALUM. WINDOW	J856-SD-PW-5357	-	-																		

IN-HOUSE DESIGN CHECKER





B.O. REF :

CLIENT : **SUN HUNG KAI REAL ESTATE AGENCY LTD.**  
42/F SUN HUNG KAI CENTRE, WINGHUA, HONGKONG

ARCHITECT : **IWK&partners**  
a t c h i t e c t s

MAIN CONTRACTOR : **怡輝建築有限公司 Yee Fai Building Contractors Ltd.**

STRUCTURAL ENGINEER : **ARUP**  
ALPHA CONSULTING LIMITED  
Steel Structure & Facade Specialist

NOTE :  
1. ALL DIMENSIONS ARE IN mm.  
2. ALL ELEVATIONS ARE VIEWED FROM OUTSIDE.  
3. ALL DIMENSIONS TO BE VERIFIED ON SITE BEFORE FABRICATION.

LEGEND :  
⊗1 --- DETAIL MARK NO.  
⊗001 --- REFER SHEET NO.  
1. F.F.L. --- FINISHED FLOOR LEVEL  
2. S.F.L. --- STRUCTURAL FLOOR LEVEL  
3. Ⓟ --- REVERSED DETAIL  
4. GLASS LEGEND  
EGL-1 --- 8mmHS+12mm AIR GAP+10mmTP THK. LG.U.  
EGL-2 --- 10mm THK. CLEAR TEMPERED GLASS  
EGL-4 --- 10mm THK. TEMPERED ACID ETCHED GLASS  
EGL-1A --- 8mmHS+12mm AIR GAP+8mmTP THK. LG.U.

Table with 2 columns: NO., DATE, REVISION SUBJECT TO AMENDMENT, REVISION

JOB NO. : J-856  
PROPOSED DEVELOPMENT ABOVE LIGHT RAIL TIN WING STOP-TSWTL NO.23, AREA 33, TIN SHUI WAI, N.T.

TITLE : DIE LIST FOR ALUM. WINDOW

DATE : 02-Aug-21 SCALE : 1:40  
DRAWN BY : Iwon CHECKED BY :  
**美特鋁質有限公司**  
Units 6-8, Sunray Industrial Centre, 1/F  
610 Chiu Kwo Ling Road, Kowloon  
Tel: 23489211-4 Fax: (852) 27277866  
DWG NO. : J856-SD-PW-1102 REV. : A

MEMBER : AW-17  
GRADE : 6063-T6  
FINISH : PVF2 3-COATING

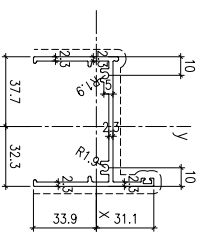

Table with 2 columns: MASS PROPERTIES (UNIT), VALUES

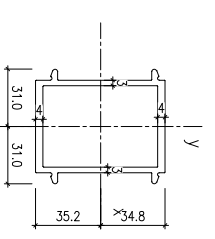

Table with 2 columns: MASS PROPERTIES (UNIT), VALUES

MEMBER : AW-18  
GRADE : 6063-T6  
FINISH : PVF2 3-COATING

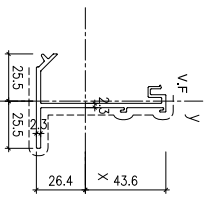

Table with 2 columns: MASS PROPERTIES (UNIT), VALUES

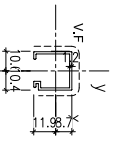

Table with 2 columns: MASS PROPERTIES (UNIT), VALUES

MEMBER : AW-19  
GRADE : 6061-T6  
FINISH : MILL

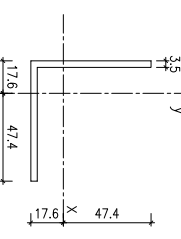

Table with 2 columns: MASS PROPERTIES (UNIT), VALUES

MEMBER : AW-20  
GRADE : 6061-T6  
FINISH : MILL

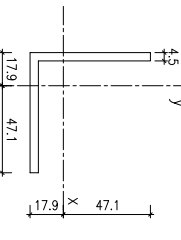

Table with 2 columns: MASS PROPERTIES (UNIT), VALUES

MEMBER : AW-21  
GRADE : 6063-T6  
FINISH : PVF2 3-COATING



Table with 2 columns: MASS PROPERTIES (UNIT), VALUES



Table with 2 columns: MASS PROPERTIES (UNIT), VALUES

MEMBER : AW-23  
GRADE : 6063-T6  
FINISH : PVF2 3-COATING

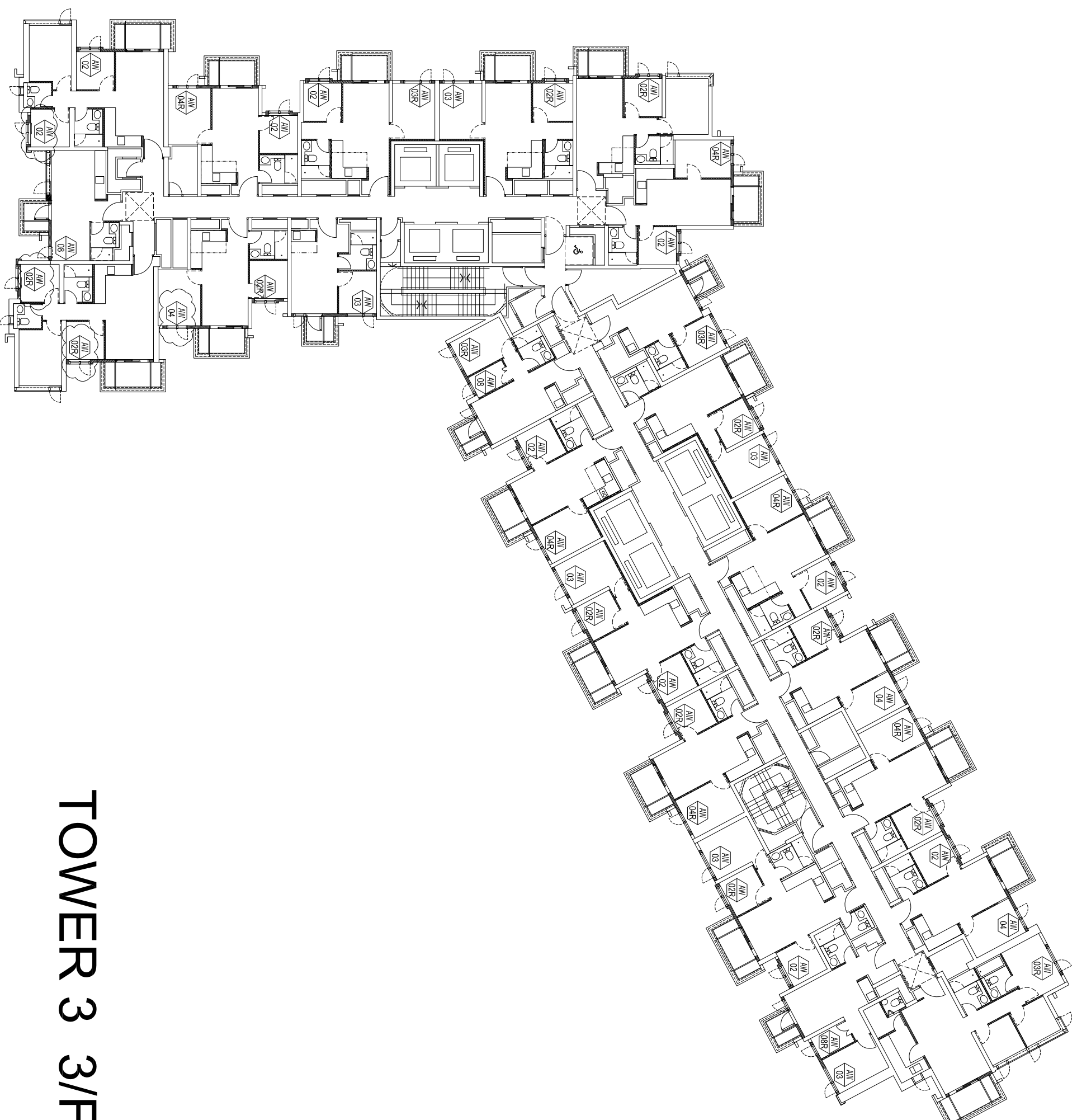

Table with 2 columns: MASS PROPERTIES (UNIT), VALUES

MEMBER : AW-24  
GRADE : 6063-T6  
FINISH : PVF2 3-COATING



Table with 2 columns: MASS PROPERTIES (UNIT), VALUES



# TOWER 3 3/F-42/F

CLIENT :

**SUN HUNG KAI**  
REAL ESTATE AGENCY LTD.

42/F SUN HUNG KAI CENTRE, WANGCHAI, HONGKONG

ARCHITECT :

**IWK&partners**  
A R C H I T E C T S

MAIN CONTRACTOR :

**怡輝建築有限公司**  
**Yee Fai** Building Contractors Ltd.

STRUCTURAL ENGINEER :

**ARUP**

FACADE CONSULTANT:

**ALPHA CONSULTING LIMITED**  
Steel Structure & Facade Specialist

NOTE :

1. ALL DIMENSIONS ARE IN mm.
2. ALL ELEVATIONS ARE VIEWED FROM OUTSIDE.
3. ALL DIMENSIONS TO BE VERIFIED ON SITE BEFORE FABRICATION.

LEGEND :

⊗1—DETAIL MARK NO.  
⊗001—REFER SHEET NO.

1. F.F.L.--FINISHED FLOOR LEVEL
2. S.F.L.--STRUCTURAL FLOOR LEVEL
3. Ⓟ--REVERSED DETAIL

4. GLASS LEGEND

EQ1-1--8mmHS+12mm AIR GAP+8mmTP THK. L.G.U.  
EQ2-2--10mm THK. CLEAR TEMPERED GLASS  
EQ4-4--10mm THK. TEMPERED ACID ETCHED GLASS

NO.	DATE	REVISION	REVISION SUBJECT TO ARCHITECTMENT
D	02/11/2021	REVISION SUBJECT TO ARCHITECTMENT	None
C	28/10/2021	REVISION SUBJECT TO ARCHITECTMENT	None
B	18/10/2021	REVISION SUBJECT TO ARCHITECTMENT	None
A	30/09/2021	REVISION SUBJECT TO ARCHITECTMENT	None

JOB NO. : J-856

PROJECT :

PROPOSED DEVELOPMENT ABOVE  
LIGHT RAIL TIN WING STOP TSWTL  
NO.23,AREA 33,TIN SHUI WAI, N.T.

TITLE :

PLAN FOR ALUM. WINDOW  
AT TOWER 3

DATE : 02-Aug-21 SCALE : 1:40

DRAWN BY : Iwon CHECKED BY :

**美特鋁寶有限公司**  
**MIDI ALUMINIUM FABRICATOR LTD.**  
Units 6-8, Sunray Industrial Centre, 1/F  
610 Cha Kwo Ling Road, Kowloon  
Tel:23489211-4 Fax:(852)27277866

DWG NO. : J856-SD-PW-3302 REV. : D

B.O. REF :

CLIENT :



42/F SUN HUNG KAI CENTRE, WINGHUA, HONGKONG

ARCHITECT :



MAIN CONTRACTOR :

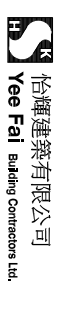

STRUCTURAL ENGINEER :



FAÇADE CONSULTANT:



NOTE :

1. ALL DIMENSIONS ARE IN mm.
2. ALL ELEVATIONS ARE VIEWED FROM OUTSIDE.
3. ALL DIMENSIONS TO BE VERIFIED ON SITE BEFORE FABRICATION.

LEGEND :

- ①② --- DETAIL MARK NO.
- ④⑤ --- REFER SHEET NO.
- 1. F.F.L. --- FINISHED FLOOR LEVEL
- 2. S.F.L. --- STRUCTURAL FLOOR LEVEL
- 3. Ⓜ --- REVERSED DETAIL
- 4. GLASS LEGEND

EGL-1--8mmHS+12mm AIR GAP+10mmTP THK. I.G.U.  
 EGL-2--10mm THK. CLEAR TEMPERED GLASS  
 EGL-4--10mm THK. TEMPERED ACID ETCHED GLASS  
 EGL-1A--8mmHS+12mm AIR GAP+8mmTP THK. I.G.U.

NO.	DATE	REVISION	SUBJECT TO AMENDMENT
C	02/11/2021	REVISION SUBJECT TO AMENDMENT	None
B	28/10/2021	REVISION SUBJECT TO AMENDMENT	None
A	18/10/2021	REVISION SUBJECT TO AMENDMENT	None

JOB NO. : J-856

PROJECT :

PROPOSED DEVELOPMENT ABOVE  
 LIGHT RAIL TIN WING STOP-TSWTL  
 NO.23,AREA 33,TIN SHUI WAI, N.T.

TITLE :

WINDOW SCHEDULE FOR  
 TOWER 3 ALUM. WINDOW

DATE : 02-Aug-21 SCALE : 1:40

DRAWN BY : von CHECKED BY :

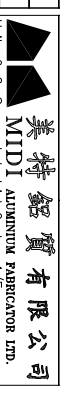

Units 6-8, Sunray Industrial Centre, 1/F  
 610 Ona Kwo Ling Road, Kowloon  
 Tel:23489211-4 Fax:(852)2727666

DWG NO. : J856-SD-PW-5301 REV. : C

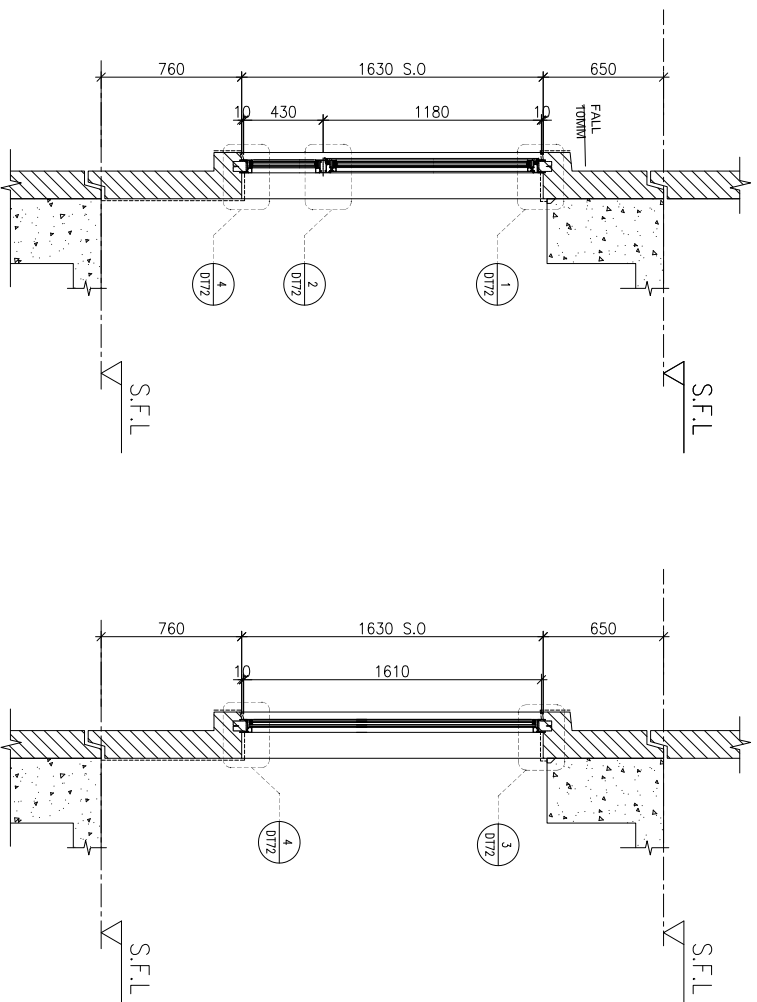
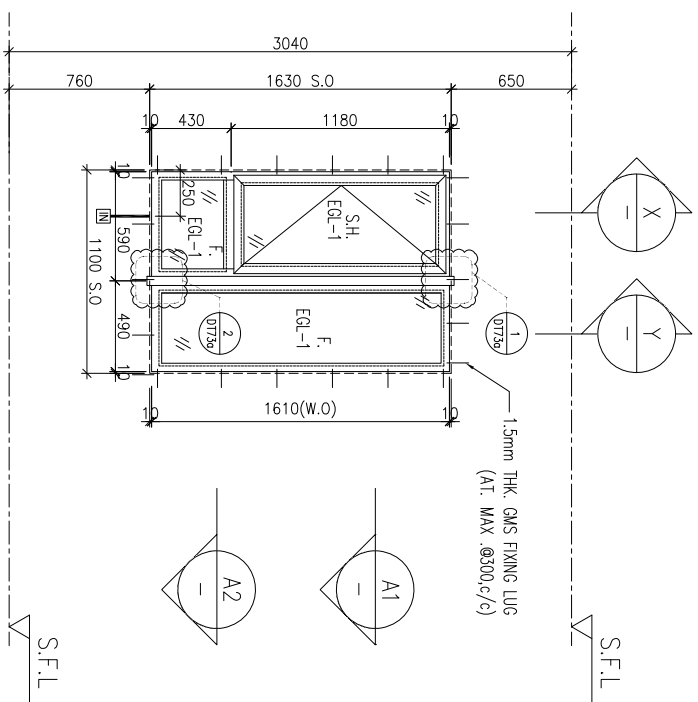

ELEVATION

A1 PART PLAN

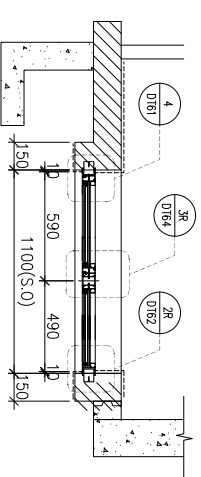
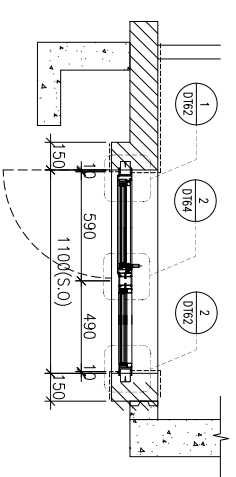

A2 PART PLAN

WINDOW MARK	SECTION	LOCATION	QUANTITY	REMARKS
AW 02	70mm ALUM. SECTION	3/F-42/F(4/F,13/F,14/F,24/F,34/F OMITTED) UNIT B6	35 Nos.	FAÇADE(TYPE T3PF02 FOR 3/F~42/F)
AW 02R	70mm ALUM. SECTION	3/F-42/F(4/F,13/F,14/F,24/F,34/F OMITTED) UNIT A9,B7,B8	35 Nos / 35 Nos / 35 Nos	FAÇADE(TYPE T3PF02R FOR 3/F~42/F)

B.O. REF :

CLIENT :

**SUN HUNG KAI**  
**REAL ESTATE AGENCY LTD.**  
 42/F SUN HUNG KAI CENTRE, WINGHUA, HONGKONG

ARCHITECT :

**IWK&partners**  
 a r c h i t e c t s

MAIN CONTRACTOR :

**怡輝建築有限公司**  
**Yee Fai Building Contractors Ltd.**

STRUCTURAL ENGINEER :

**ARUP**  
 ALPHA CONSULTING LIMITED  
 Steel Structure & Facade Specialist

FAÇADE CONSULTANT:

**ALPHA CONSULTING LIMITED**  
 Steel Structure & Facade Specialist

NOTE :

1. ALL DIMENSIONS ARE IN mm.
2. ALL ELEVATIONS ARE VIEWED FROM OUTSIDE.
3. ALL DIMENSIONS TO BE VERIFIED ON SITE BEFORE FABRICATION.

LEGEND :

- DETAIL MARK NO.
- REFER SHEET NO.
- 1. F.F.L.--FINISHED FLOOR LEVEL
- 2. S.F.L.--STRUCTURAL FLOOR LEVEL
- 3. --REVERSED DETAIL
- 4. GLASS LEGEND

EGL-1--8mmHS+12mm AIR GAP+10mmTP THK. I.G.U.  
 EGL-2--10mm THK. CLEAR TEMPERED GLASS  
 EGL-4--10mm THK. TEMPERED ACID ETCHED GLASS  
 EGL-1A--8mmHS+12mm AIR GAP+8mmTP THK. I.G.U.

NO.	DATE	REVISION	REVISION SUBJECT TO ARCHITECTMENT
D	02/11/2021	REVISION SUBJECT TO ARCHITECTMENT	None
C	26/10/2021	REVISION SUBJECT TO ARCHITECTMENT	None
B	18/10/2021	REVISION SUBJECT TO ARCHITECTMENT	None
A	27/09/2021	REVISION SUBJECT TO ARCHITECTMENT	None

JOB NO. : J-856

PROJECT :

PROPOSED DEVELOPMENT ABOVE  
 LIGHT RAIL TIN WING STOP-TSWTL  
 NO.23,AREA 33,TIN SHUI WAI, N.T.

TITLE :

WINDOW SCHEDULE FOR  
 TOWER 3 ALUM. WINDOW

DATE : 02-Aug-21 SCALE : 1:40

DRAWN BY : Non CHECKED BY :

**美特經貿有限公司**  
**MIDI Aluminium Fabricator Ltd.**  
 Units 6-8, Sunray Industrial Centre, 1/F  
 610 Ona Kwo Ling Road, Kowloon  
 Tel:23489211-4 Fax:(852)2727866  
 DWG NO. : J856-SD-PW-5302 REV. : D

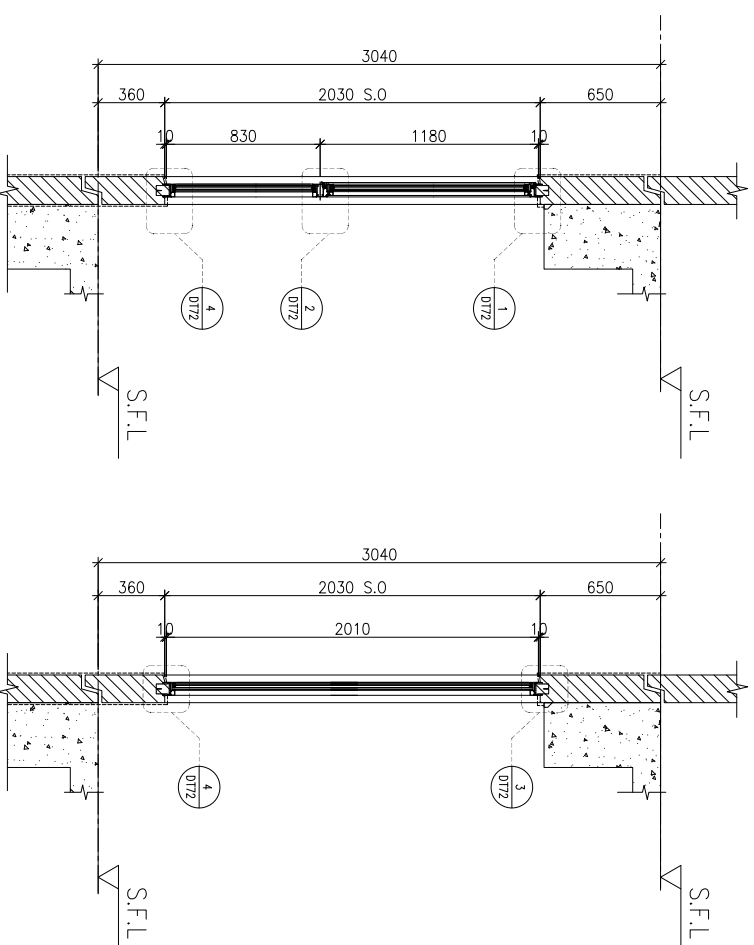
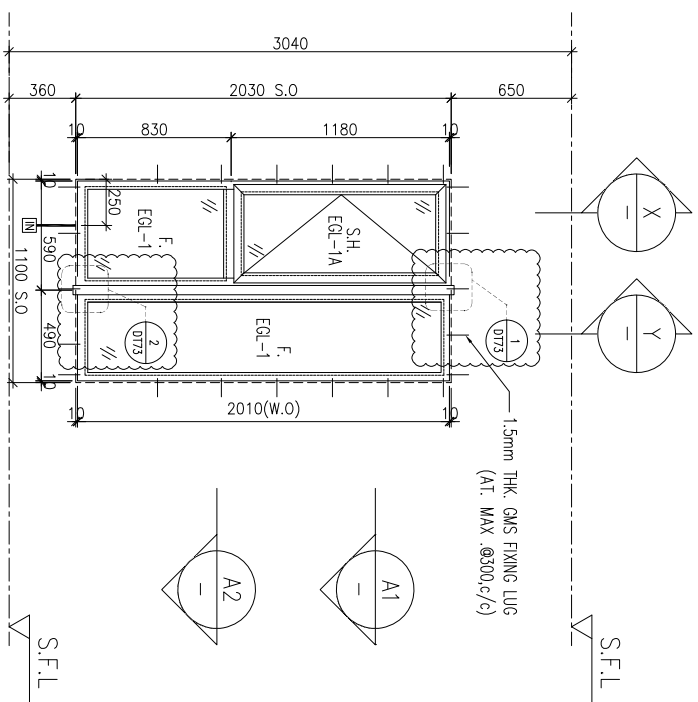

ELEVATION

A1 PART PLAN

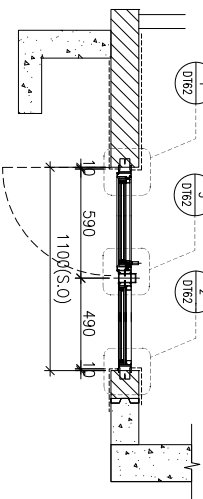

A2 PART PLAN

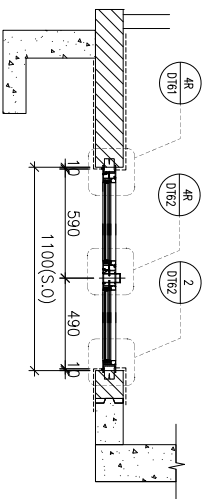

WINDOW MARK	
LOCATION	3/F-42/F(4/F,13/F,14/F,24/F,34/F OMITTED) UNIT A3,A6,A10,A12,B5,B9
SECTION	70mm ALUM. SECTION
GLAZING	EGL-1
QUANTITY	35 Nos / 35 Nos / 35 Nos / 35 Nos / 35 Nos
REMARKS	FAÇADE(TYPE T3PF04R FOR 3/F~42/F)

WINDOW MARK	
LOCATION	3/F-42/F(4/F,13/F,14/F,24/F,34/F OMITTED) UNIT A11,A13,B11
SECTION	70mm ALUM. SECTION
GLAZING	EGL-1
QUANTITY	35 Nos / 35 Nos / 35 Nos
REMARKS	FAÇADE(TYPE T3PF04R FOR 3/F~42/F)

B.O. REF :

CLIENT :

**SUN HUNG KAI**  
REAL ESTATE AGENCY LTD.  
42/F SUN HUNG KAI CENTRE, WINGHUA, HONGKONG

ARCHITECT :  
**lwk&partners**  
A R C H I T E C T S

MAIN CONTRACTOR :  
**怡輝建築有限公司**  
Yee Fai Building Contractors Ltd.

STRUCTURAL ENGINEER :

**ARUP**

FAÇADE CONSULTANT:  
**ALPHA CONSULTING LIMITED**  
Steel Structure & Façade Specialist

NOTE:  
1. ALL DIMENSIONS ARE IN mm.  
2. ALL ELEVATIONS ARE VIEWED FROM OUTSIDE.  
3. ALL DIMENSIONS TO BE VERIFIED ON SITE BEFORE FABRICATION.

LEGEND:

- DETAIL MARK NO.
- REFER SHEET NO.
- 1. F.F.L.--FINISHED FLOOR LEVEL
- 2. S.F.L.--STRUCTURAL FLOOR LEVEL
- 3. --REVERSED DETAIL
- 4. GLASS LEGEND

EGL-1--8mmHS+12mm AIR GAP+10mmTP THK. I.G.U.  
EGL-2--10mm THK. CLEAR TEMPERED GLASS  
EGL-4--10mm THK. TEMPERED ACID ETCHED GLASS  
EGL-1A--8mmHS+12mm AIR GAP+8mmTP THK. I.G.U.

NO.	DATE	REVISION	REVISION SUBJECT TO ARCHITECTMENT
D	02/11/2021	REVISION SUBJECT TO ARCHITECTMENT	None
C	26/10/2021	REVISION SUBJECT TO ARCHITECTMENT	None
B	18/10/2021	REVISION SUBJECT TO ARCHITECTMENT	None
A	27/09/2021	REVISION SUBJECT TO ARCHITECTMENT	None

JOB NO. : J-856

PROJECT :  
PROPOSED DEVELOPMENT ABOVE  
LIGHT RAIL TIN WING STOP TSWTL  
NO.23,AREA 33,TIN SHUI WAI, N.T.

TITLE :  
WINDOW SCHEDULE FOR  
TOWER 3 ALUM. WINDOW

DATE : 02-Aug-21 SCALE : 1:40

DRAWN BY : von CHECKED BY :

**美特經貿有限公司**  
MIDI Aluminium Fabricator Ltd.  
Units 6-8, Sunray Industrial Centre, 1/F  
610 Ona Kwo Ling Road, Kowloon  
Tel:23489211-4 Fax:(852)2727866  
DWG NO. : J856-SD-PW-5303 REV. : D

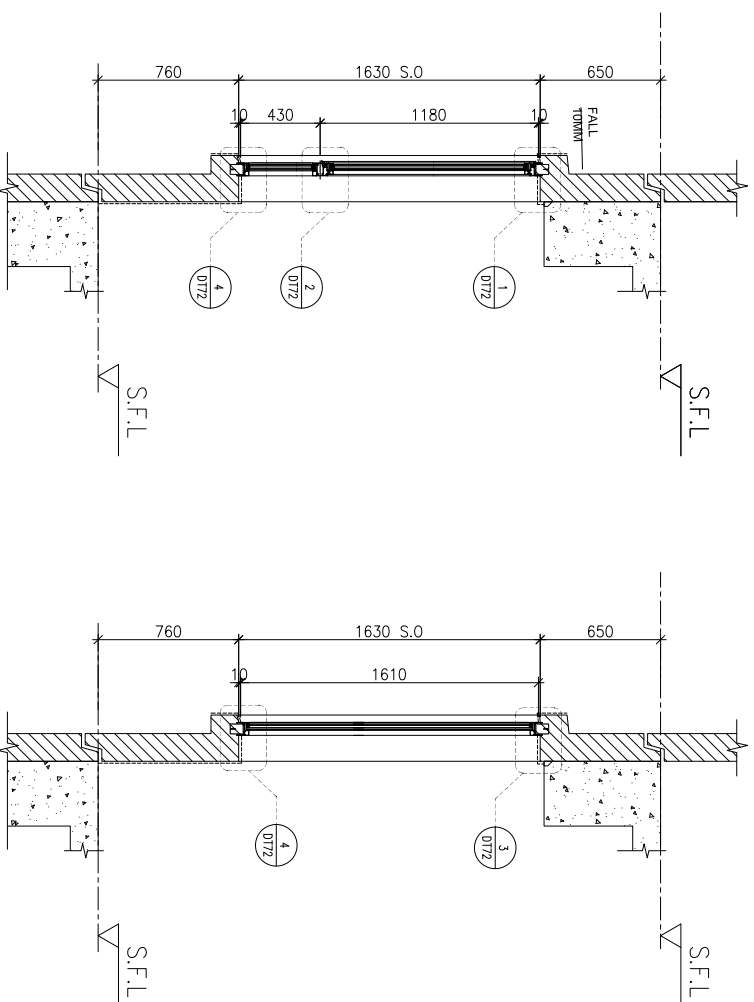
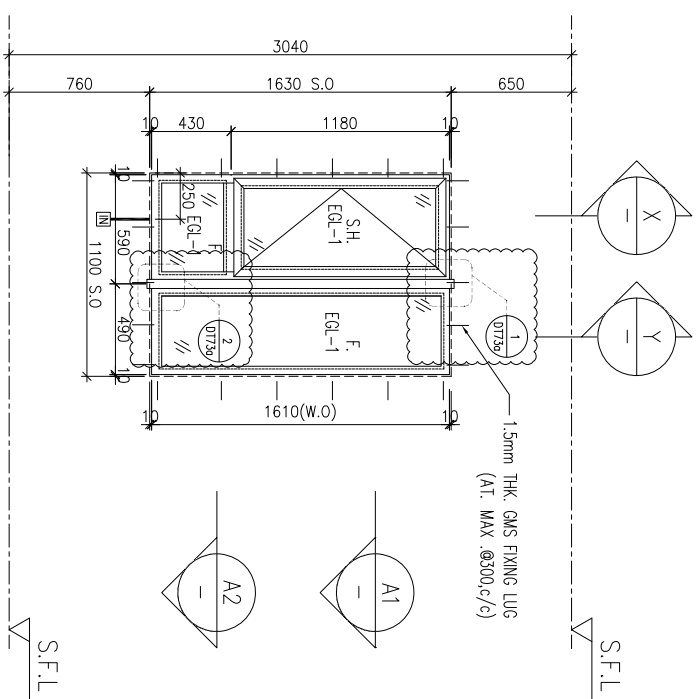

ELEVATION

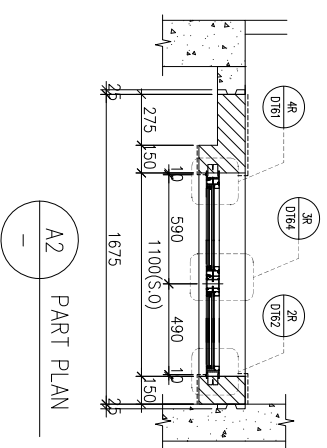
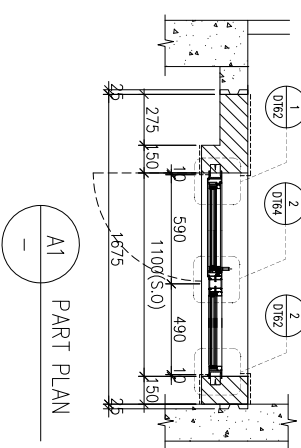

WINDOW MARK	
LOCATION	3/F-42/F(4/F,13/F,14/F,24/F,34/F OMITTED) UNIT A2,A10,A6,B3,B5,B9
SECTION	70mm ALUM. SECTION
GLAZING	EGL-1
QUANTITY	35 Nos / 35 Nos / 35 Nos / 35 Nos / 35 Nos / 35 Nos
REMARKS	FAÇADE(TYPE T3PF05R FOR 3/F~42/F)

WINDOW MARK	
LOCATION	3/F-42/F(4/F,13/F,14/F,24/F,34/F OMITTED) UNIT A11,B1,B11
SECTION	70mm ALUM. SECTION
GLAZING	EGL-1
QUANTITY	35 Nos / 35 Nos / 35 Nos / 35 Nos
REMARKS	FAÇADE(TYPE T3PF05 FOR 3/F~42/F)

B.O. REF :

CLIENT :



42/F SUN HUNG KAI CENTRE, WINGHAI, HONGKONG

ARCHITECT :



MAIN CONTRACTOR :

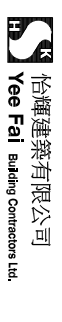

STRUCTURAL ENGINEER :



FAÇADE CONSULTANT:



Steel Structure & Façade Specialist

NOTE :

1. ALL DIMENSIONS ARE IN mm.
2. ALL ELEVATIONS ARE VIEWED FROM OUTSIDE.
3. ALL DIMENSIONS TO BE VERIFIED ON SITE BEFORE FABRICATION.

LEGEND :

- ①1— DETAIL MARK NO.
- ①001— REFER SHEET NO.

1. F.F.L.--FINISHED FLOOR LEVEL
2. S.F.L.--STRUCTURAL FLOOR LEVEL
3. Ⓜ--REVERSED DETAIL
4. GLASS LEGEND

EGL-1--8mmHS+12mm AIR GAP+10mmTP THK. I.G.U.  
 EGL-2--10mm THK. CLEAR TEMPERED GLASS  
 EGL-4--10mm THK. TEMPERED ACID ETCHED GLASS  
 EGL-1A--8mmHS+12mm AIR GAP+8mmTP THK. I.G.U.

NO.	DATE	REVISION
D	02/11/2021	REVISION SUBJECT TO ARCH/COMMITMENT
C	26/10/2021	REVISION SUBJECT TO ARCH/COMMITMENT
B	18/10/2021	REVISION SUBJECT TO ARCH/COMMITMENT
A	27/09/2021	REVISION SUBJECT TO ARCH/COMMITMENT

JOB NO. : J-856

PROJECT :

PROPOSED DEVELOPMENT ABOVE  
 LIGHT RAIL TIN WING STOP TSWTL  
 NO.23,AREA 33,TIN SHUI WAI, N.T.

TITLE :

WINDOW SCHEDULE FOR  
 TOWER 3 ALUM. WINDOW

DATE : 02-Aug-21 SCALE : 1:40

DRAWN BY : Ivon CHECKED BY :



Units 6-8, Sunray Industrial Centre, 1/F  
 610 Ona Kwo Ling Road, Kowloon  
 Tel:23489211-4 Fax:(852)27278666

DWG NO. : J856-SD-PW-5304 REV. : D

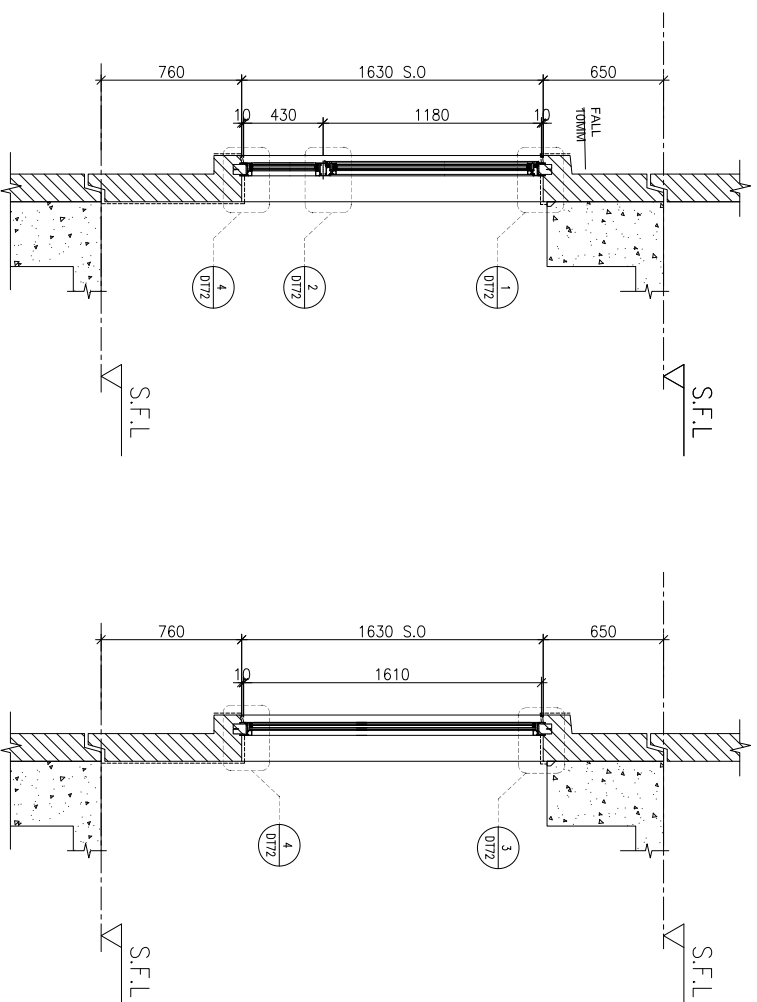
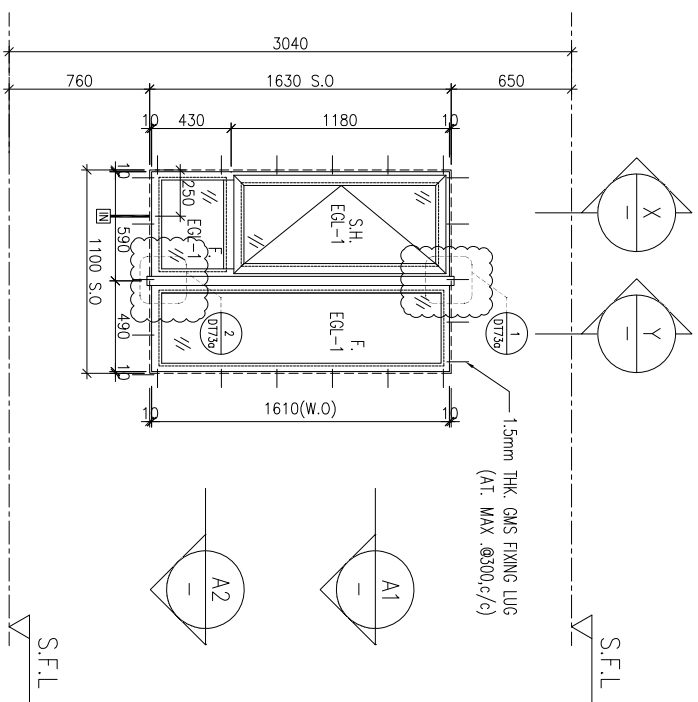

ELEVATION

A1 PART PLAN

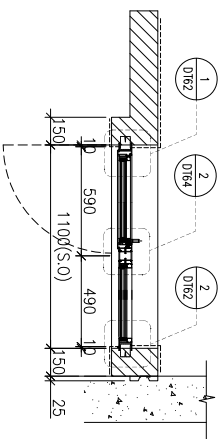

A2 PART PLAN

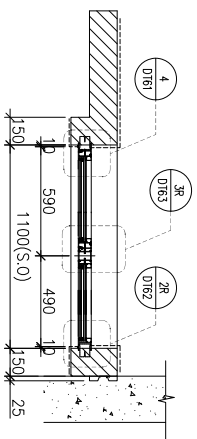

WINDOW MARK



LOCATION

3/F-42/F(4/F,13/F,14/F,24/F,34/F OMITTED) UNIT B3

SECTION

70mm ALUM. SECTION

GLAZING

EGL-1

QUANTITY

35 Nos

REMARKS

FAÇADE(TYPE T3PF08R FOR 3/F~42/F)

B.O. REF :

CLIENT :

**SUN HUNG KAI**  
REAL ESTATE AGENCY LTD.  
42/F SUN HUNG KAI CENTRE, WINGLOU, HONGKONG

ARCHITECT :

**lwk&partners**  
a r c h i t e c t s

MAIN CONTRACTOR :

**怡輝建築有限公司**  
**Yee Fai** Building Contractors Ltd.

STRUCTURAL ENGINEER :

**ARUP**  
ALPHA CONSULTING LIMITED  
Steel Structure & Facade Specialist

FAÇADE CONSULTANT:

**ALPHA CONSULTING LIMITED**  
Steel Structure & Facade Specialist

NOTE :

1. ALL DIMENSIONS ARE IN mm.
2. ALL ELEVATIONS ARE VIEWED FROM OUTSIDE.
3. ALL DIMENSIONS TO BE VERIFIED ON SITE BEFORE FABRICATION.

LEGEND :

- DETAIL MARK NO.
- REFER SHEET NO.
- 1. F.F.L.--FINISHED FLOOR LEVEL
- 2. S.F.L.--STRUCTURAL FLOOR LEVEL
- 3. --REVERSED DETAIL
- 4. GLASS LEGEND

EGL-1--8mmHS+12mm AIR GAP+10mmTP THK. I.G.U.  
EGL-2--10mm THK. CLEAR TEMPERED GLASS  
EGL-4--10mm THK. TEMPERED ACID ETCHED GLASS  
EGL-1A--8mmHS+12mm AIR GAP+8mmTP THK. I.G.U.

NO.	DATE	REVISION	REVISION SUBJECT TO ARCHITECTMENT
D	02/11/2021	REVISION SUBJECT TO ARCHITECTMENT	None
C	26/10/2021	REVISION SUBJECT TO ARCHITECTMENT	None
B	18/10/2021	REVISION SUBJECT TO ARCHITECTMENT	None
A	27/09/2021	REVISION SUBJECT TO ARCHITECTMENT	None

JOB NO. : J-856

PROJECT :

PROPOSED DEVELOPMENT ABOVE  
LIGHT RAIL TIN WING STOP-TSWTL  
NO.23,AREA 33,TIN SHUI WAI, N.T.

TITLE :

WINDOW SCHEDULE FOR  
TOWER 3 ALUM. WINDOW

DATE : 02-Aug-21 SCALE : 1:40

DRAWN BY : Iwon CHECKED BY :

**美特經貿有限公司**  
MIDI Aluminium Fabricator Ltd.  
Units 6-8, Sunray Industrial Centre, 1/F  
610 Ona Kwo Ling Road, Kowloon  
Tel:23489211-4 Fax:(852)2727866

DWG NO. : J856-SD-PW-5305 REV. : D

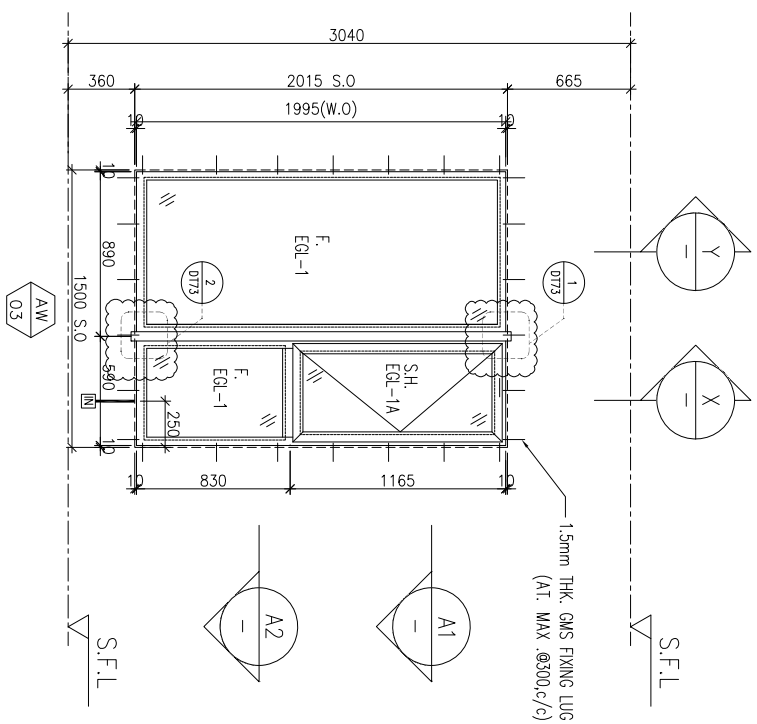

ELEVATION

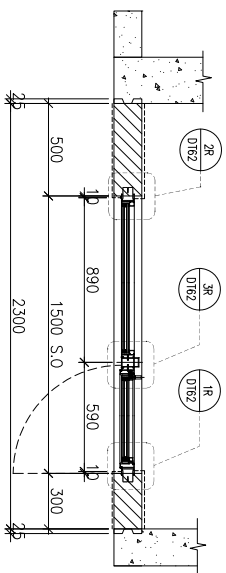
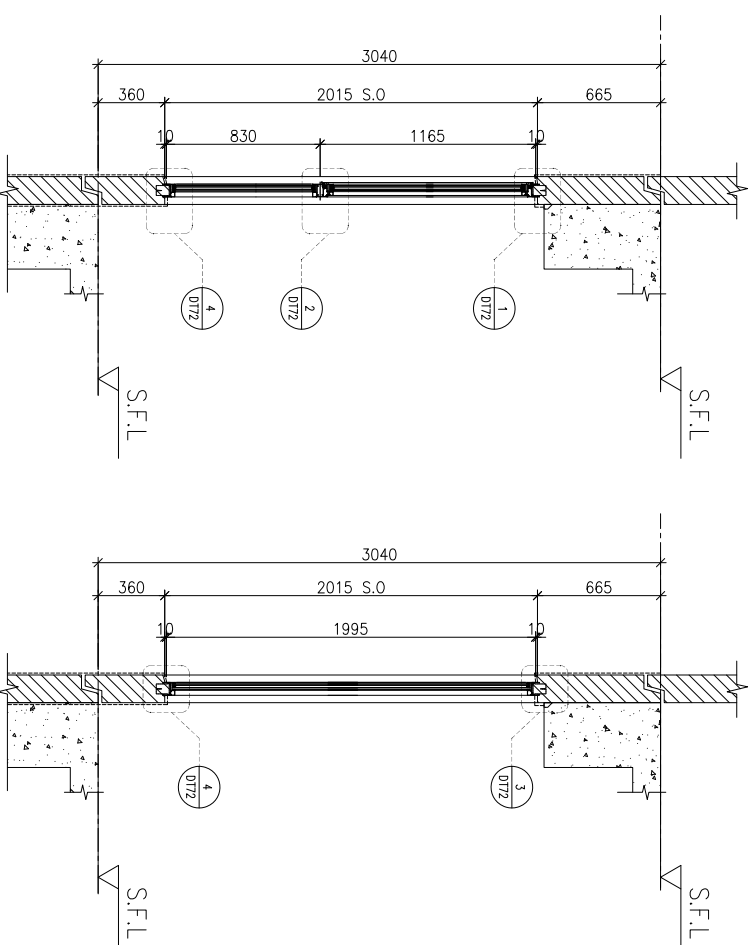

A1 PART PLAN

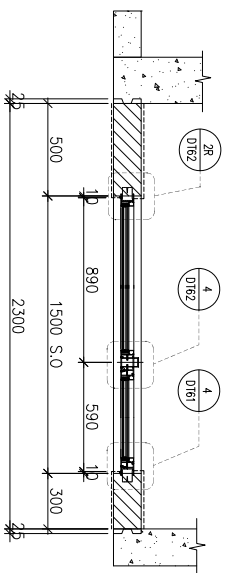

A2 PART PLAN

WINDOW MARK	LOCATION	SECTION	QUANTITY	REMARKS
	3/F-42/F(4/F,13/F,14/F,24/F,34/F OMITTED) UNIT A2,A5,A9,B7	70mm ALUM. SECTION	35 Nos / 35 Nos / 35 Nos	FAÇADE(TYPE T3PF10 FOR 3/F~42/F)
	3/F-42/F(4/F,13/F,14/F,24/F,34/F OMITTED) UNIT A8,A15,B6	70mm ALUM. SECTION	35 Nos / 35 Nos / 35 Nos	FAÇADE(TYPE T3PF10R FOR 3/F~42/F)

B.O. REF :

CLIENT :

**SUN HUNG KAI**  
REAL ESTATE AGENCY LTD.  
42/F SUN HUNG KAI CENTRE, WANGCHAI, HONGKONG

ARCHITECT :

**Iwk&partners**  
A R C H I T E C T S

MAIN CONTRACTOR :

**怡輝建築有限公司**  
Yee Fai Building Contractors Ltd.

STRUCTURAL ENGINEER :

**ARUP**

FAÇADE CONSULTANT:

**ALPHA CONSULTING LIMITED**  
Steel Structure & Façade Specialist

NOTE :

1. ALL DIMENSIONS ARE IN mm.
2. ALL ELEVATIONS ARE VIEWED FROM OUTSIDE.
3. ALL DIMENSIONS TO BE VERIFIED ON SITE BEFORE FABRICATION.

LEGEND :

⊗1 --- DETAIL MARK NO.  
X001 --- REFER SHEET NO.

1. F.F.L.--FINISHED FLOOR LEVEL
2. S.F.L.--STRUCTURAL FLOOR LEVEL
3. Ⓟ --- REVERSED DETAIL
4. GLASS LEGEND

EGL-1--8mmHS+12mm AIR GAP+10mmTP THK. I.G.U.  
 EGL-2--10mm THK. CLEAR TEMPERED GLASS  
 EGL-4--10mm THK. TEMPERED ACID ETCHED GLASS  
 EGL-1A--8mmHS+12mm AIR GAP+8mmTP THK. I.G.U.

NO.	DATE	REVISION	REVISION SUBJECT TO ARCHITECTMENT
C	02/11/2021	REVISION SUBJECT TO ARCHITECTMENT	None
B	28/10/2021	REVISION SUBJECT TO ARCHITECTMENT	None
A	27/09/2021	REVISION SUBJECT TO ARCHITECTMENT	None

JOB NO. : J-856

PROJECT :

PROPOSED DEVELOPMENT ABOVE  
LIGHT RAIL TIN WING STOP-TSWTL  
NO.23,AREA 33,TIN SHUI WAI, N.T.

TITLE :

WINDOW SCHEDULE FOR  
TOWER 3 ALUM. WINDOW

DATE : 02-Aug-21 SCALE : 1:40

DRAWN BY : Ivon CHECKED BY :

**美特鋁業有限公司**  
MIDI Aluminium Fabricator Ltd.  
Units 6-8, Sunray Industrial Centre, 1/F  
610 Ona Kwo Ling Road, Kowloon  
Tel:23489211-4 Fax:(852)2727666

DWG NO. : J856-SD-PW-5306 REV. : C

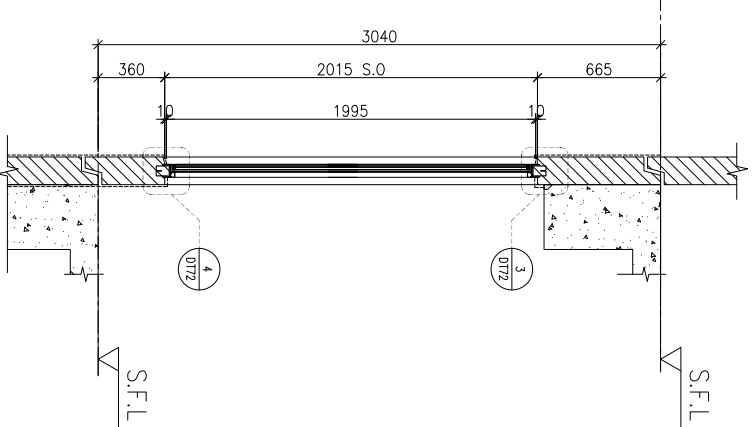
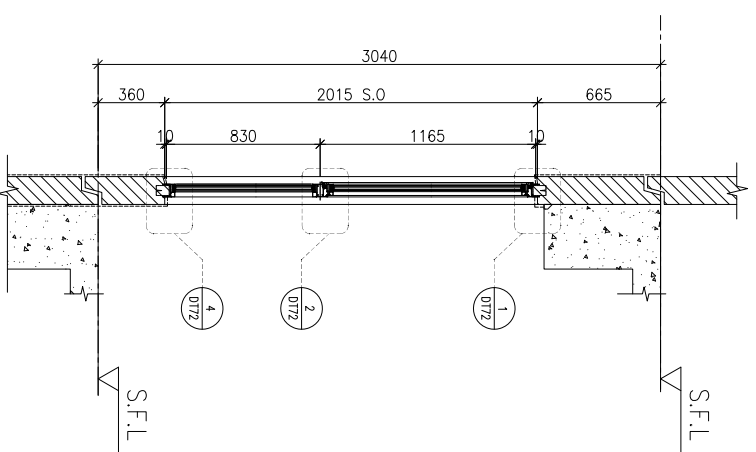
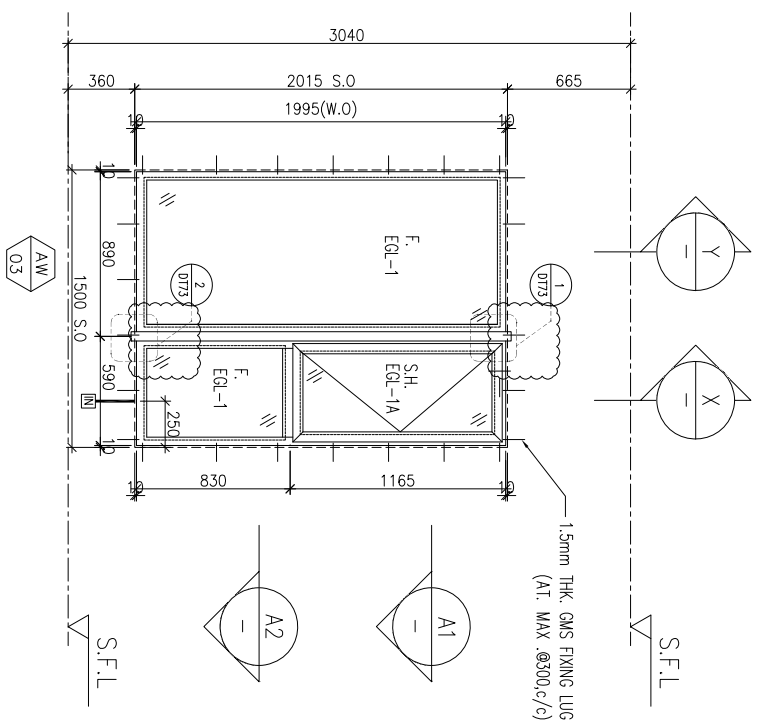

ELEVATION

A1 PART PLAN

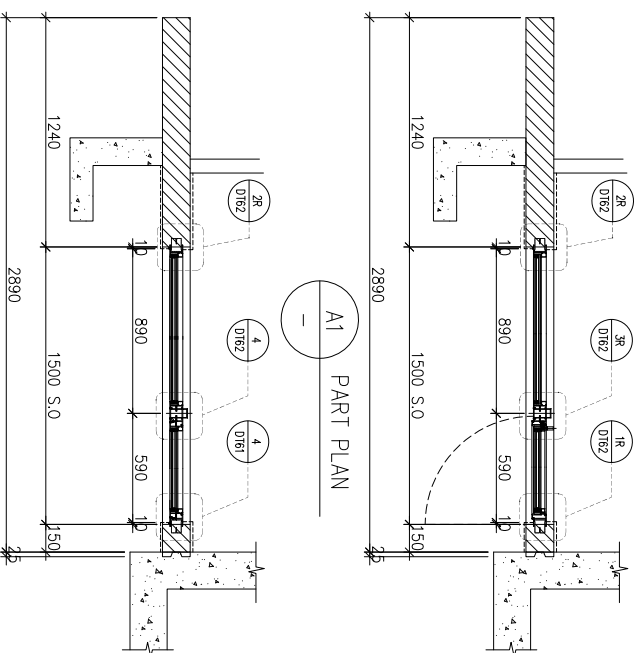

A2 PART PLAN

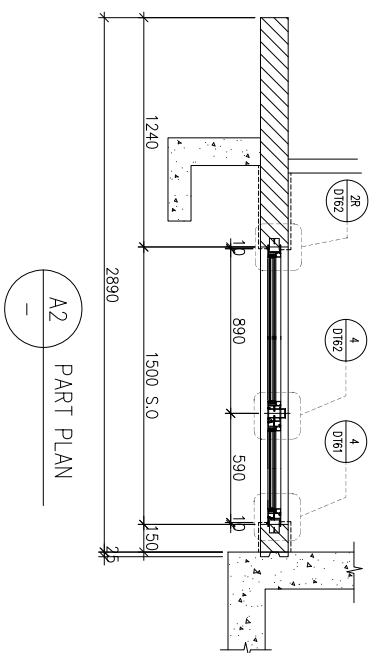

WINDOW MARK	AW 03
LOCATION	3/F-42/F(4/F,13/F,14/F,24/F,34/F OMITTED) UNIT B10
SECTION	70mm ALUM. SECTION
GLAZING	EGL-1
QUANTITY	35 Nos
REMARKS	FAÇADE TYPE T3PF11R FOR 3/F~42/F

B.O. REF :

CLIENT :

**SUN HUNG KAI**  
REAL ESTATE AGENCY LTD.  
42/F SUN HUNG KAI CENTRE, WINGLOH, HONGKONG

ARCHITECT :  
**Iwk&partners**  
A R C H I T E C T S

MAIN CONTRACTOR :  
**怡輝建築有限公司**  
Yee Fai Building Contractors Ltd.

STRUCTURAL ENGINEER :  
**ARUP**

FAÇADE CONSULTANT:  
**ALPHA CONSULTING LIMITED**  
Steel Structure & Façade Specialist

NOTE:  
1. ALL DIMENSIONS ARE IN mm.  
2. ALL ELEVATIONS ARE VIEWED FROM OUTSIDE.  
3. ALL DIMENSIONS TO BE VERIFIED ON SITE BEFORE FABRICATION.

LEGEND :

ⓧ1 --- DETAIL MARK NO.  
ⓧ001 --- REFER SHEET NO.

1. F.F.L. -- FINISHED FLOOR LEVEL  
2. S.F.L. -- STRUCTURAL FLOOR LEVEL  
3. Ⓡ --- REVERSED DETAIL

4. GLASS LEGEND  
EGL-1 -- 8mmHS+12mm AIR GAP+10mmTP THK. I.G.U.  
EGL-2 -- 10mm THK. CLEAR TEMPERED GLASS  
EGL-4 -- 10mm THK. TEMPERED ACID ETCHED GLASS  
EGL-1A -- 8mmHS+12mm AIR GAP+8mmTP THK. I.G.U.

NO.	DATE	REVISION
C	02/11/2021	REVISION SUBJECT TO ARCH/COMMITMENT
B	28/10/2021	REVISION SUBJECT TO ARCH/COMMITMENT
A	27/09/2021	REVISION SUBJECT TO ARCH/COMMITMENT

JOB NO. : J-856

PROJECT :  
PROPOSED DEVELOPMENT ABOVE  
LIGHT RAIL TIN WING STOP-TSWTL  
NO.23,AREA 33,TIN SHUI WAI, N.T.

TITLE :  
WINDOW SCHEDULE FOR  
TOWER 3 ALUM. WINDOW

DATE : 02-Aug-21 SCALE : 1:40

DRAWN BY : von CHECKED BY :

**美特經貿有限公司**  
MIDI Aluminium Fabricator Ltd.  
Units 6-8, Sunray Industrial Centre, 1/F  
610 Ona Kwo Ling Road, Kowloon  
Tel:23489211-4 Fax:(852)27277666  
DWG NO. : J856-SD-PW-5307 REV. : C

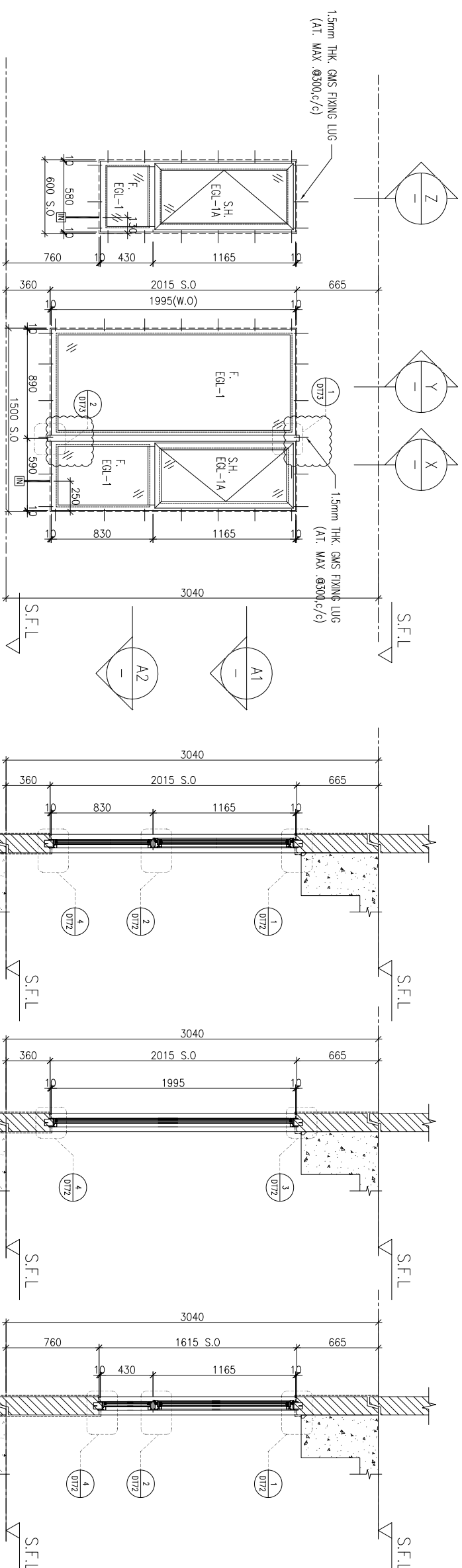

AW 08R

AW 03

X

Y

Z

S.F.L.

S.F.L.

S.F.L.

S.F.L.

S.F.L.

A1 PART PLAN

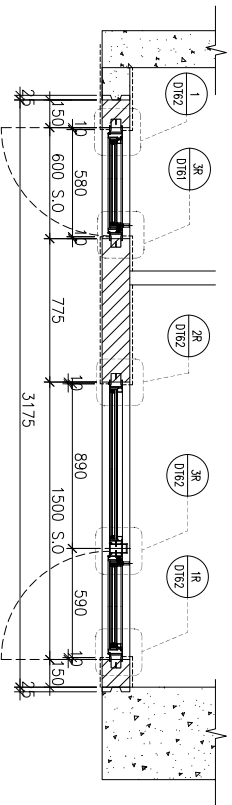

A2 PART PLAN

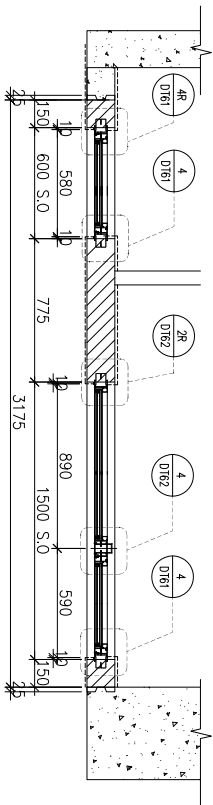

WINDOW MARK	AW 03	AW 08R
LOCATION	3/F-42/F(4/F,13/F,14/F,24/F,34/F OMITTED) UNIT A1	
SECTION	70mm ALUM. SECTION	
GLAZING	EGL-1	
QUANTITY	35 Nos	
REMARKS	FAÇADE(TYPE T3PF15 FOR 3/F~42/F)	

WINDOW MARK	AW 03R	AW 08
LOCATION	3/F-42/F(4/F,13/F,14/F,24/F,34/F OMITTED) UNIT A7	
SECTION	70mm ALUM. SECTION	
GLAZING	EGL-1	
QUANTITY	35 Nos	
REMARKS	FAÇADE(TYPE T3PF15R FOR 3/F~42/F)	

B.O. REF :

CLIENT :

**SUN HUNG KAI**  
REAL ESTATE AGENCY LTD.  
42/F SUN HUNG KAI CENTRE, WANGCHAI, HONGKONG

ARCHITECT :  
**lwk&partners**  
a r c h i t e c t s

MAIN CONTRACTOR :  
**怡輝建築有限公司**  
Yee Fai Building Contractors Ltd.

STRUCTURAL ENGINEER :  
**ARUP**

FAÇADE CONSULTANT:  
**ALPHA CONSULTING LIMITED**  
Steel Structure & Façade Specialist

NOTE:  
1. ALL DIMENSIONS ARE IN mm.  
2. ALL ELEVATIONS ARE VIEWED FROM OUTSIDE.  
3. ALL DIMENSIONS TO BE VERIFIED ON SITE BEFORE FABRICATION.

LEGEND :

- ⓧ1 DETAIL MARK NO.
- ⓧ001 REFER SHEET NO.
- 1. F.F.L.--FINISHED FLOOR LEVEL
- 2. S.F.L.--STRUCTURAL FLOOR LEVEL
- 3. ⓧR --REVERSED DETAIL
- 4. GLASS LEGEND

EGL-1--8mmHS+12mm AIR GAP+10mmTP THK. I.G.U.  
EGL-2--10mm THK. CLEAR TEMPERED GLASS  
EGL-4--10mm THK. TEMPERED ACID ETCHED GLASS  
EGL-1A--8mmHS+12mm AIR GAP+8mmTP THK. I.G.U.

NO.	DATE	REVISION
D	02/11/2021	REVISION SUBJECT TO ARCHITECTMENT
C	28/10/2021	REVISION SUBJECT TO ARCHITECTMENT
B	18/10/2021	REVISION SUBJECT TO ARCHITECTMENT
A	27/09/2021	REVISION SUBJECT TO ARCHITECTMENT

JOB NO. : J-856

PROJECT :  
PROPOSED DEVELOPMENT ABOVE  
LIGHT RAIL TIN WING STOP TSWTL  
NO.23,AREA 33,TIN SHUI WAI, N.T.

TITLE :  
WINDOW SCHEDULE FOR  
TOWER 3 ALUM. WINDOW

DATE : 02-Aug-21 SCALE : 1:40

DRAWN BY : Ivon CHECKED BY :

**美特經貿有限公司**  
MIDI Aluminium Fabricator Ltd.  
Units 6-8, Sunray Industrial Centre, 1/F  
610 Ona Kwo Ling Road, Kowloon  
Tel:23489211-4 Fax:(852)27277866

DWG NO. : J856-SD-PW-5308 REV. : D

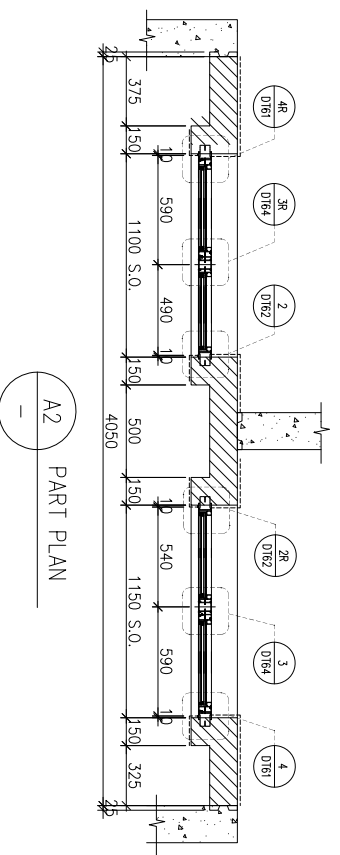
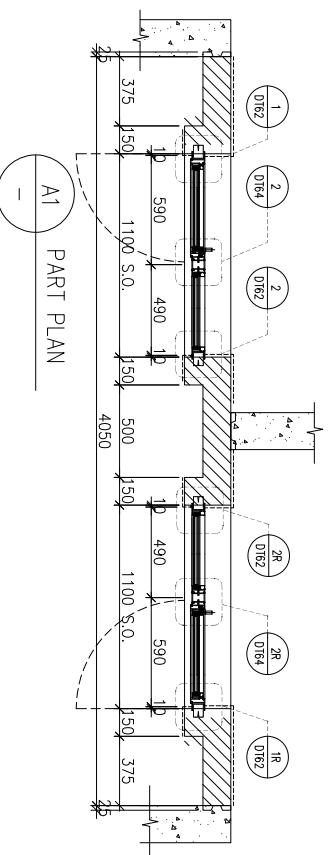
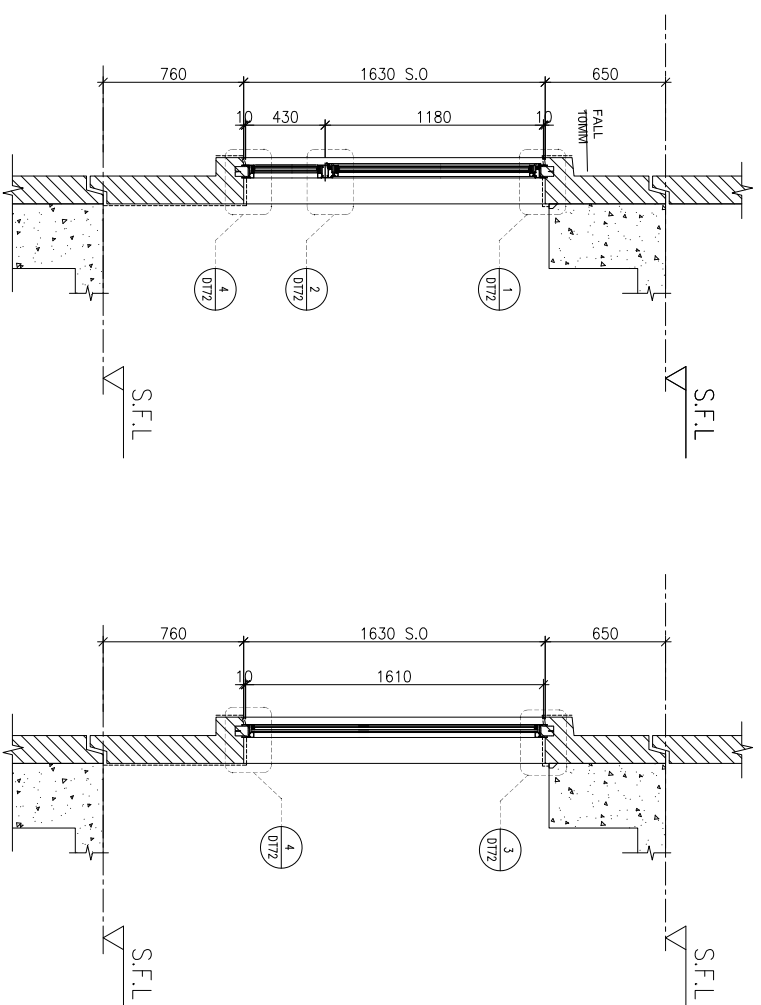
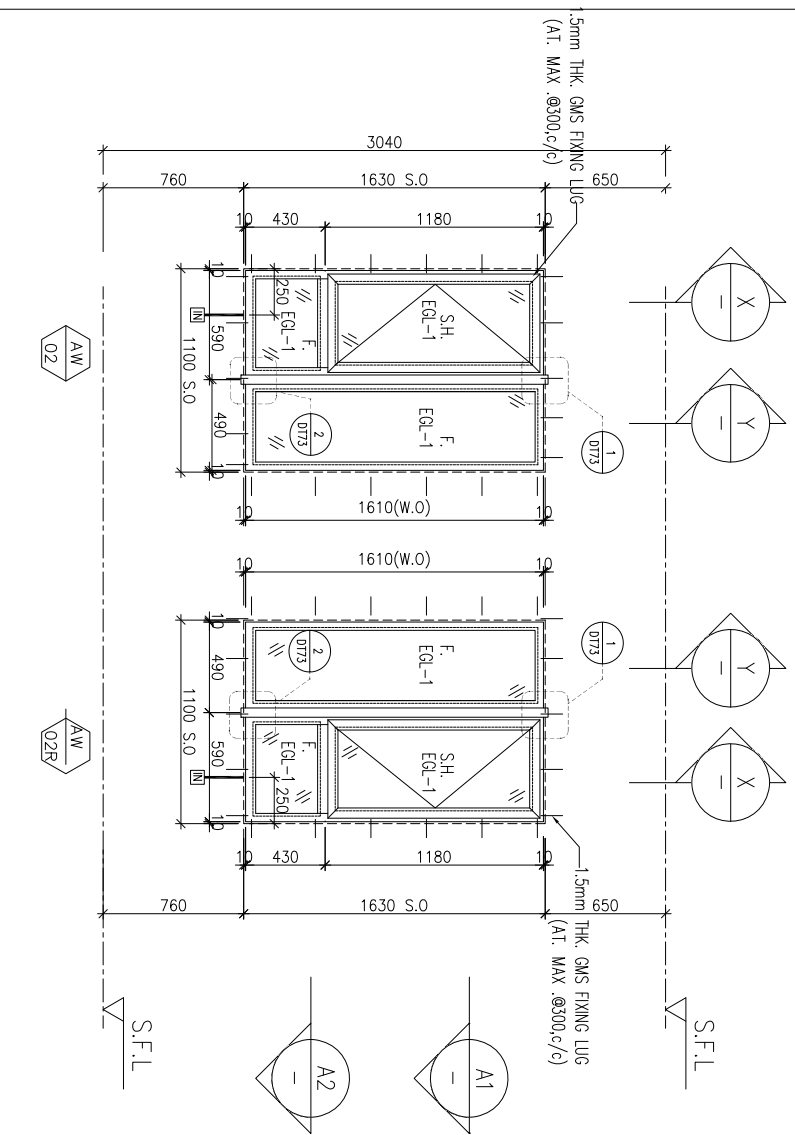

ELEVATION

WINDOW MARK	AW 02	AW 02R
LOCATION	3/F-42/F(4/F,13/F,14/F,24/F,34/F OMITTED) UNIT A3&A5, A12&A13	
SECTION	70mm ALUM. SECTION	
GLAZING	EGL-1	
QUANTITY	35 Nos	35 Nos
REMARKS	FAÇADE TYPE T3PF16 FOR 3/F~42/F	

B.O. REF :

CLIENT :

**SUN HUNG KAI**  
**REAL ESTATE AGENCY LTD.**  
42/F SUN HUNG KAI CENTRE, WANGCHAI, HONGKONG

ARCHITECT :

**lwk&partners**  
a r c h i t e c t s

MAIN CONTRACTOR :

**怡輝建築有限公司**  
**Yee Fai Building Contractors Ltd.**

STRUCTURAL ENGINEER :

**ARUP**  
ALPHA CONSULTING LIMITED  
Steel Structure & Facade Specialist

FAÇADE CONSULTANT:

**ALPHA CONSULTING LIMITED**  
Steel Structure & Facade Specialist

NOTE :

1. ALL DIMENSIONS ARE IN mm.
2. ALL ELEVATIONS ARE VIEWED FROM OUTSIDE.
3. ALL DIMENSIONS TO BE VERIFIED ON SITE BEFORE FABRICATION.

LEGEND :

⊗1—DETAIL MARK NO.  
⊗2001—REFER SHEET NO.

1. F.F.L.--FINISHED FLOOR LEVEL
2. S.F.L.--STRUCTURAL FLOOR LEVEL
3. Ⓡ --REVERSED DETAIL
4. GLASS LEGEND

EGL-1--8mmHS+12mm AIR GAP+10mmTP THK. I.G.U.  
EGL-2--10mm THK. CLEAR TEMPERED GLASS  
EGL-4--10mm THK. TEMPERED ACID ETCHED GLASS  
EGL-1A--8mmHS+12mm AIR GAP+8mmTP THK. I.G.U.

NO.	DATE	REVISION
D	02/11/2021	REVISION SUBJECT TO ARCHITECTMENT
C	26/10/2021	REVISION SUBJECT TO ARCHITECTMENT
B	18/10/2021	REVISION SUBJECT TO ARCHITECTMENT
A	27/09/2021	REVISION SUBJECT TO ARCHITECTMENT

JOB NO. : J-856

PROJECT :

PROPOSED DEVELOPMENT ABOVE  
LIGHT RAIL TIN WING STOP-TSWTL  
NO.23,AREA 33,TIN SHUI WAI, N.T.

TITLE :

WINDOW SCHEDULE FOR  
TOWER 3 ALUM. WINDOW

DATE : 02-Aug-21 SCALE : 1:40

DRAWN BY : Ivon CHECKED BY :

**美特經貿有限公司**  
**MIDI Aluminium Fabricator Ltd.**  
Units 6-8, Sunray Industrial Centre, 1/F  
610 Ona Kwo Ling Road, Kowloon  
Tel:23489211-4 Fax:(852)27277666

DWG NO. : J856-SD-PW-5309 REV. : D

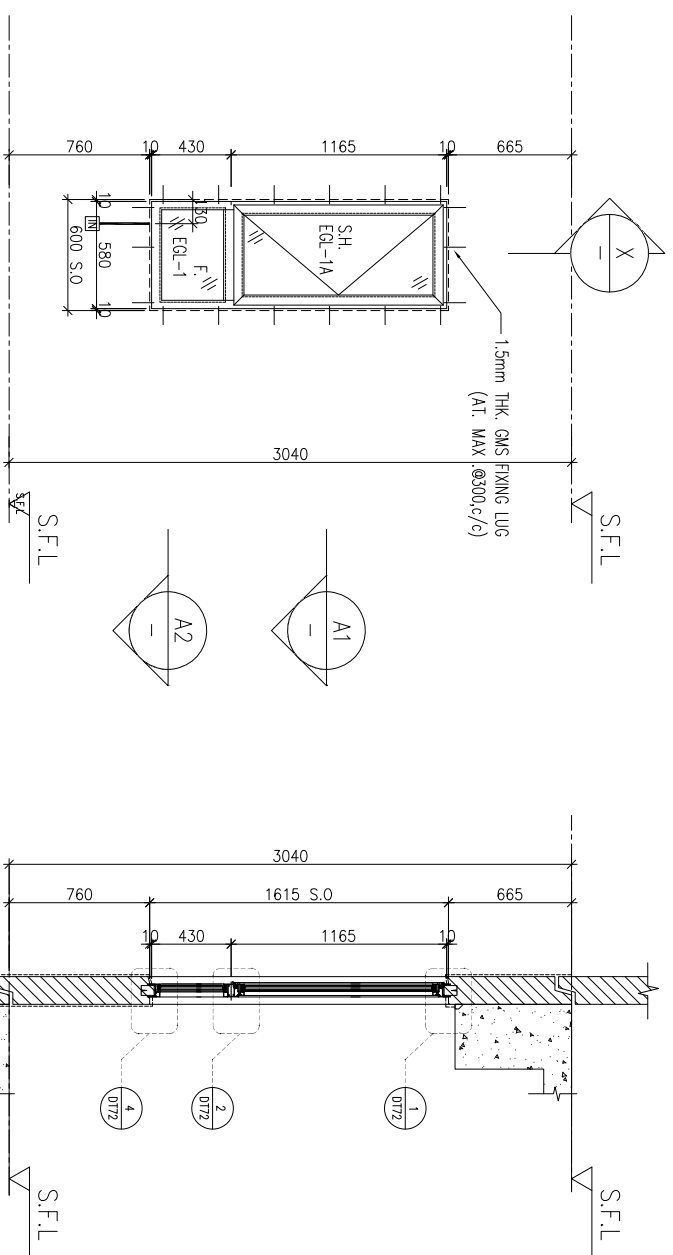

ELEVATION

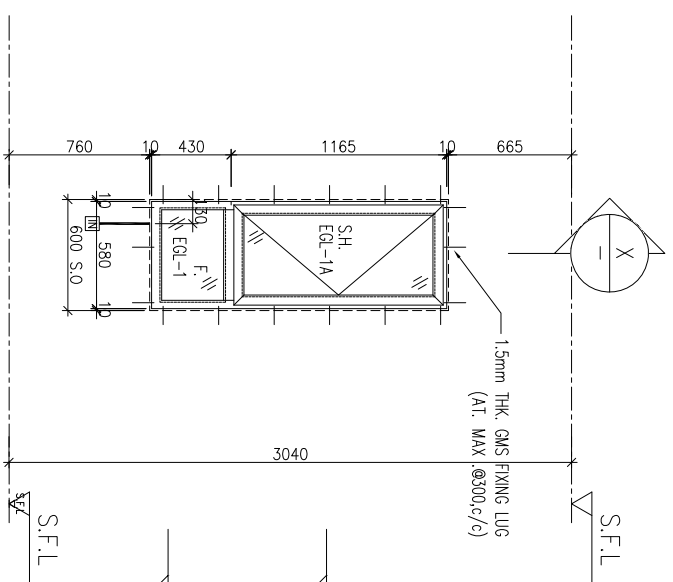

PART SECTION

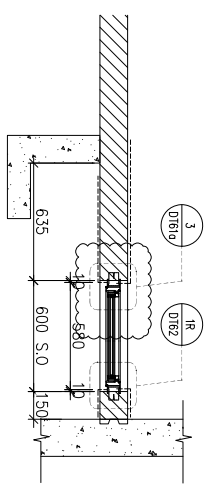

PART PLAN

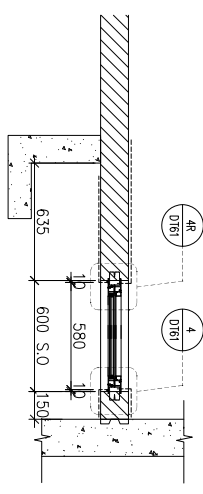

PART PLAN

WINDOW MARK	AW 08
LOCATION	3/F-42/F(4/F,13/F,14/F,24/F,34/F OMITTED) UNIT B2
SECTION	70mm ALUM. SECTION
GLAZING	EGL-1
QUANTITY	35 Nos
REMARKS	FAÇADE(TYPE T3PF18 FOR 3/F~42/F)



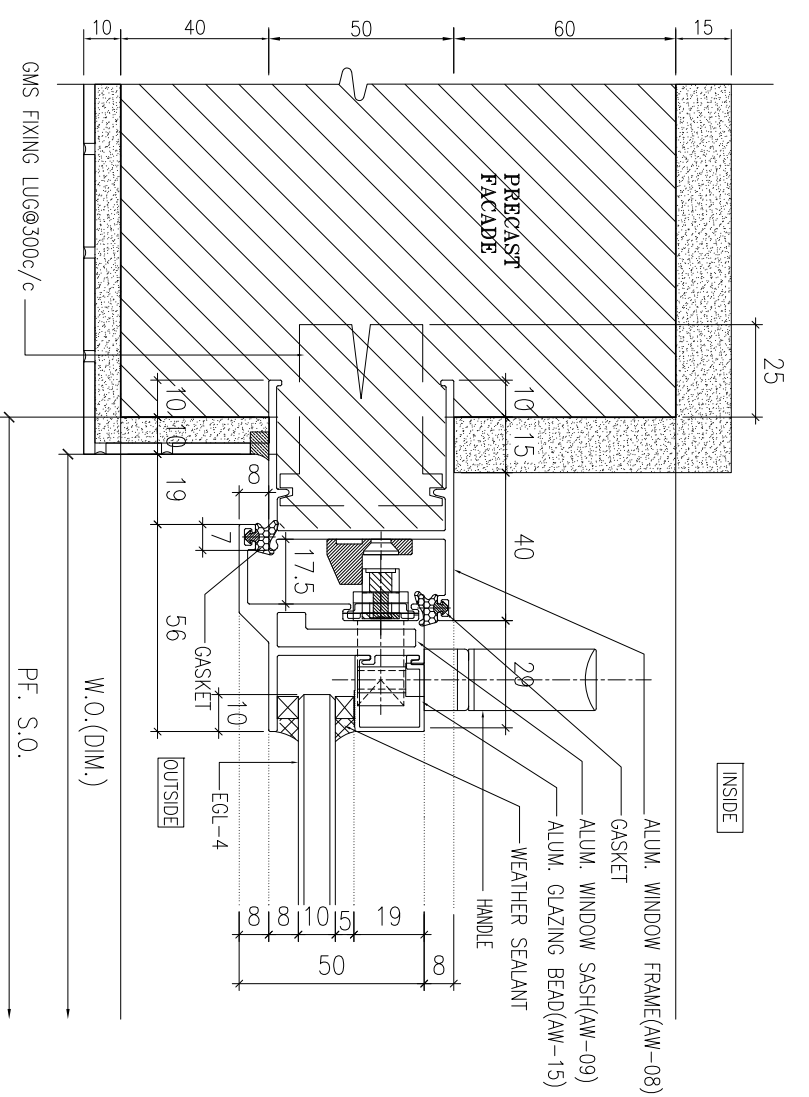

1 HORIZONTAL DETAIL  
SCALE 1:2

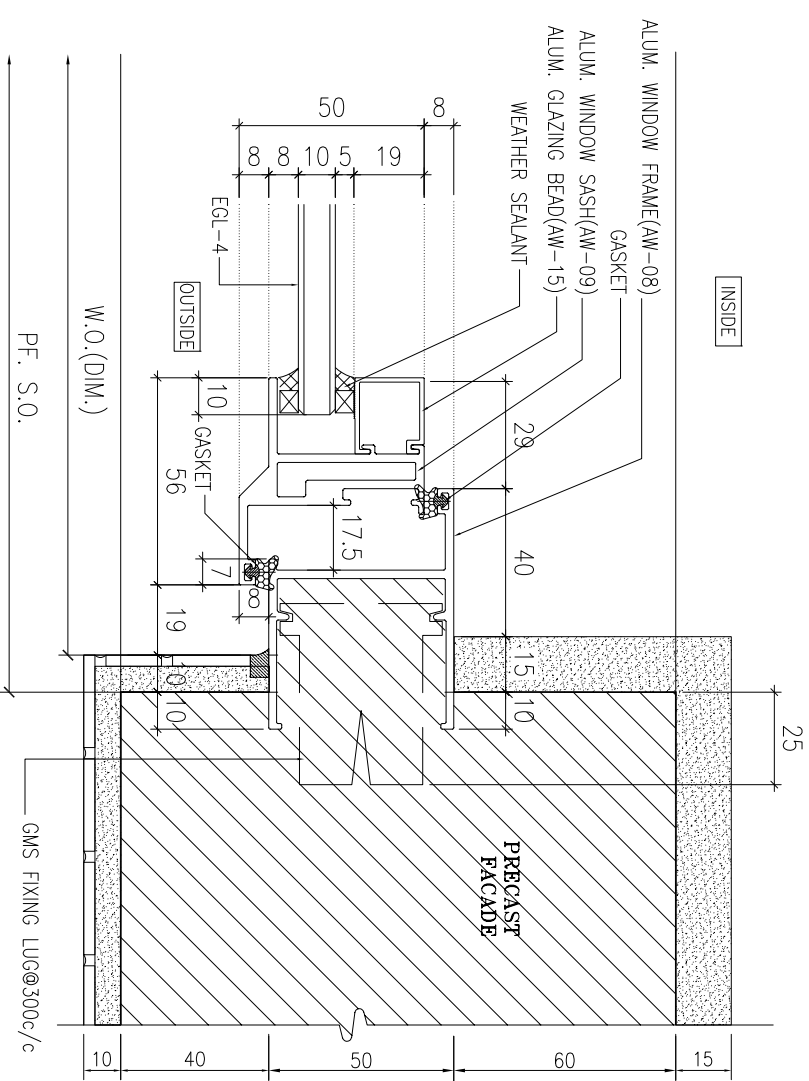

2 HORIZONTAL DETAIL  
SCALE 1:2

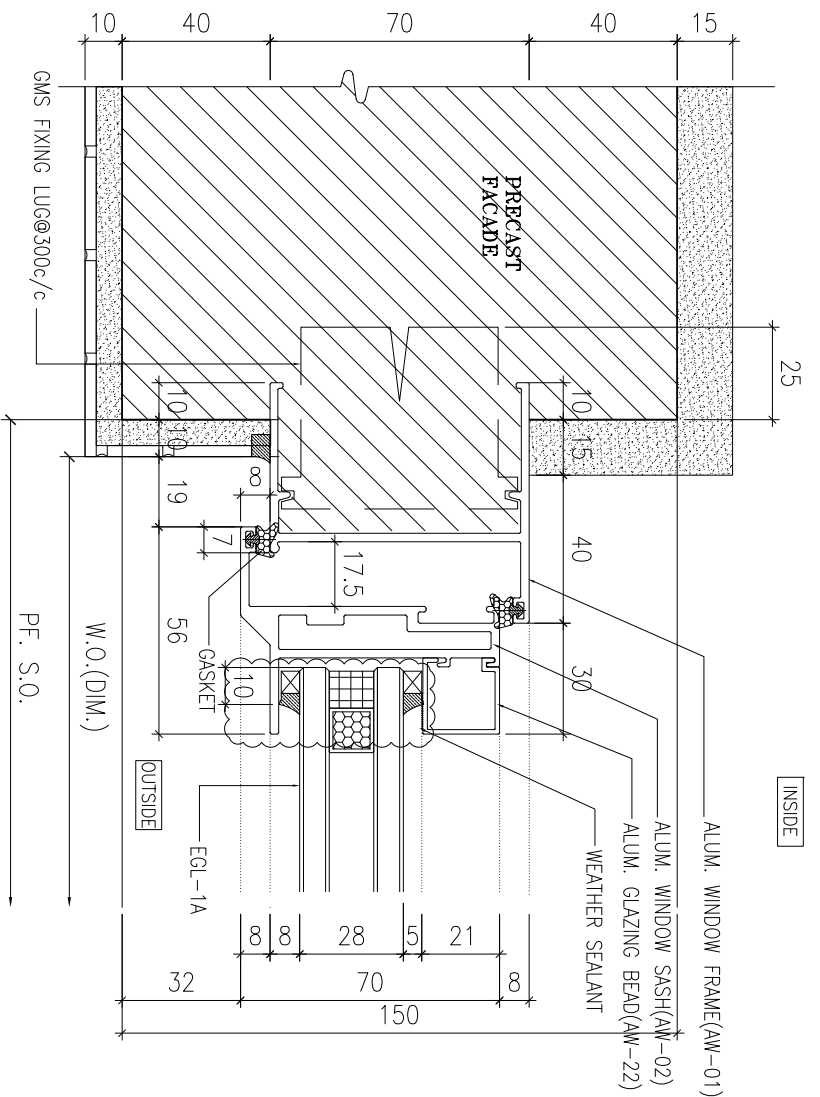

3 HORIZONTAL DETAIL  
SCALE 1:2

B.O. REF :

CLIENT :

**SUN HUNG KAI**  
REAL ESTATE AGENCY LTD.  
42/F SUN HUNG KAI CENTRE, WINGLOH, HONGKONG

ARCHITECT :

**lw&partners**  
A R C H I T E C T S

MAIN CONTRACTOR :

**怡輝建築有限公司**  
**Yee Fai** Building Contractors Ltd.

STRUCTURAL ENGINEER :

**ARUP**

FAÇADE CONSULTANT:

**ALPHA CONSULTING LIMITED**  
Steel Structure & Façade Specialist

NOTE :

1. ALL DIMENSIONS ARE IN mm.
2. ALL ELEVATIONS ARE VIEWED FROM OUTSIDE.
3. ALL DIMENSIONS TO BE VERIFIED ON SITE BEFORE FABRICATION.

LEGEND :

- ⊗1 --- DETAIL MARK NO.
- ⊗001 --- REFER SHEET NO.

1. F.F.L. --- FINISHED FLOOR LEVEL
2. S.F.L. --- STRUCTURAL FLOOR LEVEL
3. ⊗ --- REVERSED DETAIL

4. GLASS LEGEND

- EGL-1 --- 8mmHS+12mm AIR GAP+10mmTP THK. LG.U.
- EGL-2 --- 10mm THK. CLEAR TEMPERED GLASS
- EGL-4 --- 10mm THK. TEMPERED ACID ETCHED GLASS
- EGL-1A --- 8mmHS+12mm AIR GAP+8mmTP THK. LG.U.

NO.	DATE	REVISION	SUBJECT TO ARCHITECTMENT	BY
B	02/11/2021	REVISION SUBJECT TO ARCHITECTMENT		WON
A	30/10/2021	REVISION SUBJECT TO ARCHITECTMENT		WON

JOB NO. : J-856

PROJECT : PROPOSED DEVELOPMENT ABOVE LIGHT RAIL TIN WING STOP TSWTL NO.23, AREA 33, TIN SHUI WAI, N.T.

TITLE : TYPICAL DETAILS FOR ALUM. WINDOW

DATE : 02-Aug-21 SCALE : 1:40

DRAWN BY : Iwon CHECKED BY :

**美特鋁質有限公司**  
**MIDI ALUMINIUM FABRICATOR LTD.**  
Units 6-8, Sunray Industrial Centre, 1/F  
610 Ona Kwo Ling Road, Kowloon  
Tel:23489211-4 Fax:(852)2727866  
DWG NO. : J856-SD-PW-DT61a REV. : B

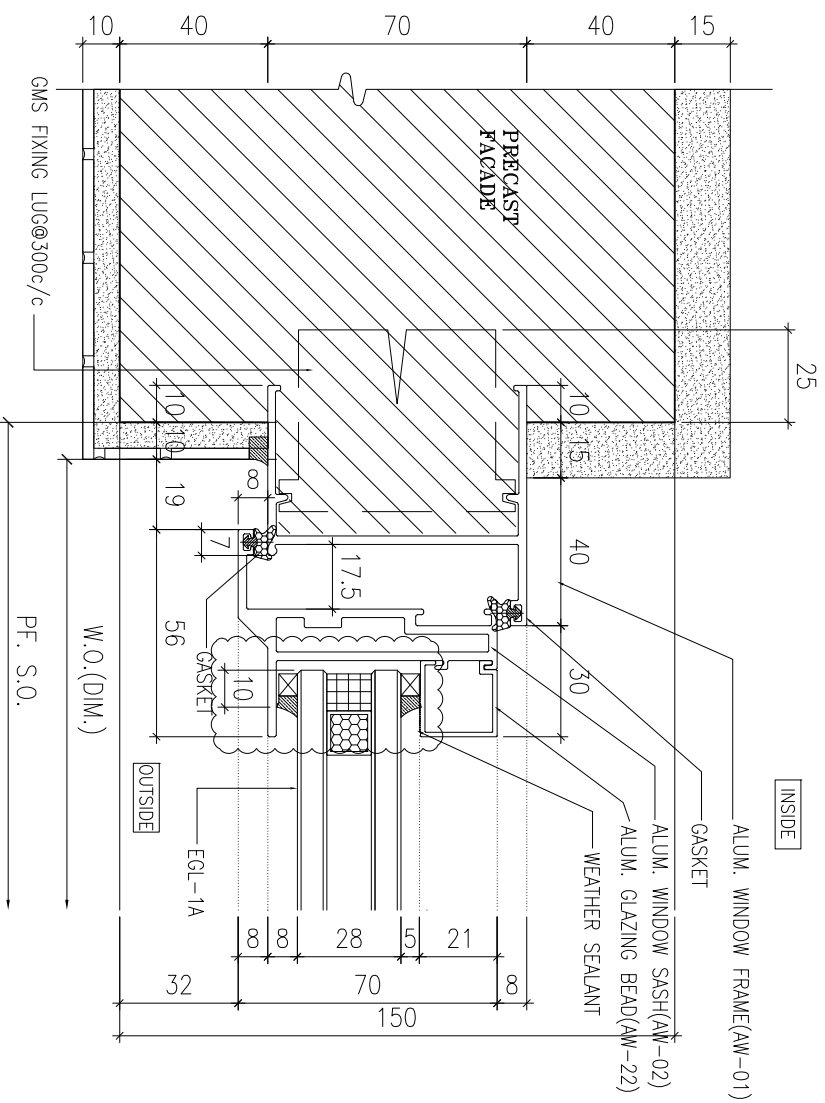

1 HORIZONTAL DETAIL  
SCALE 1:2

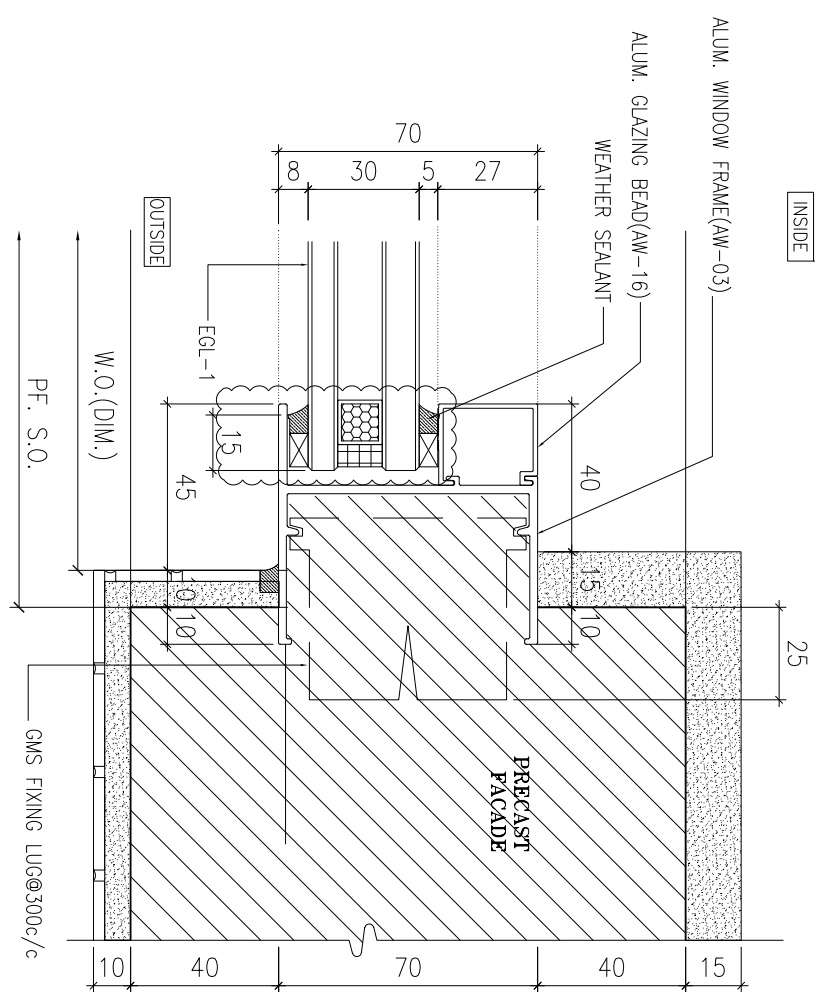

2 HORIZONTAL DETAIL  
SCALE 1:2

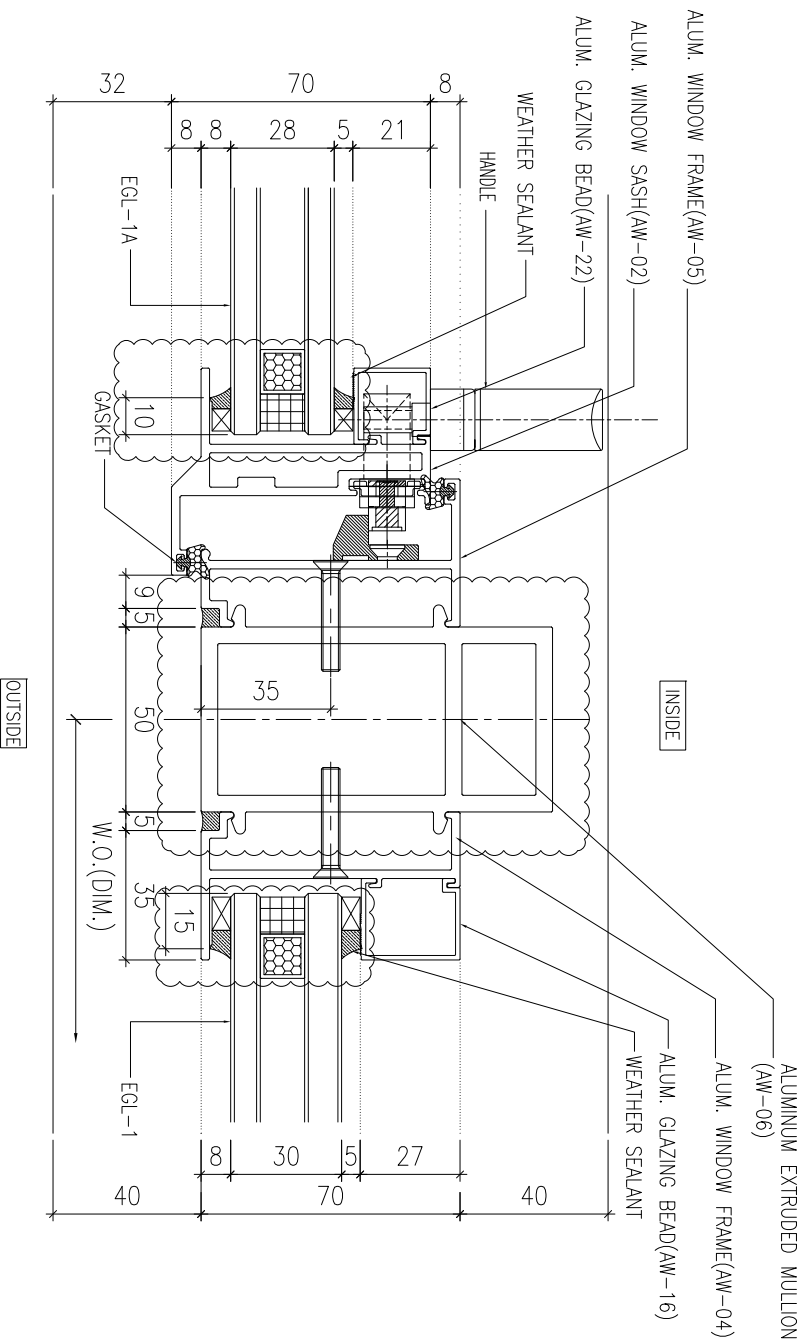

3 HORIZONTAL DETAIL  
SCALE 1:2

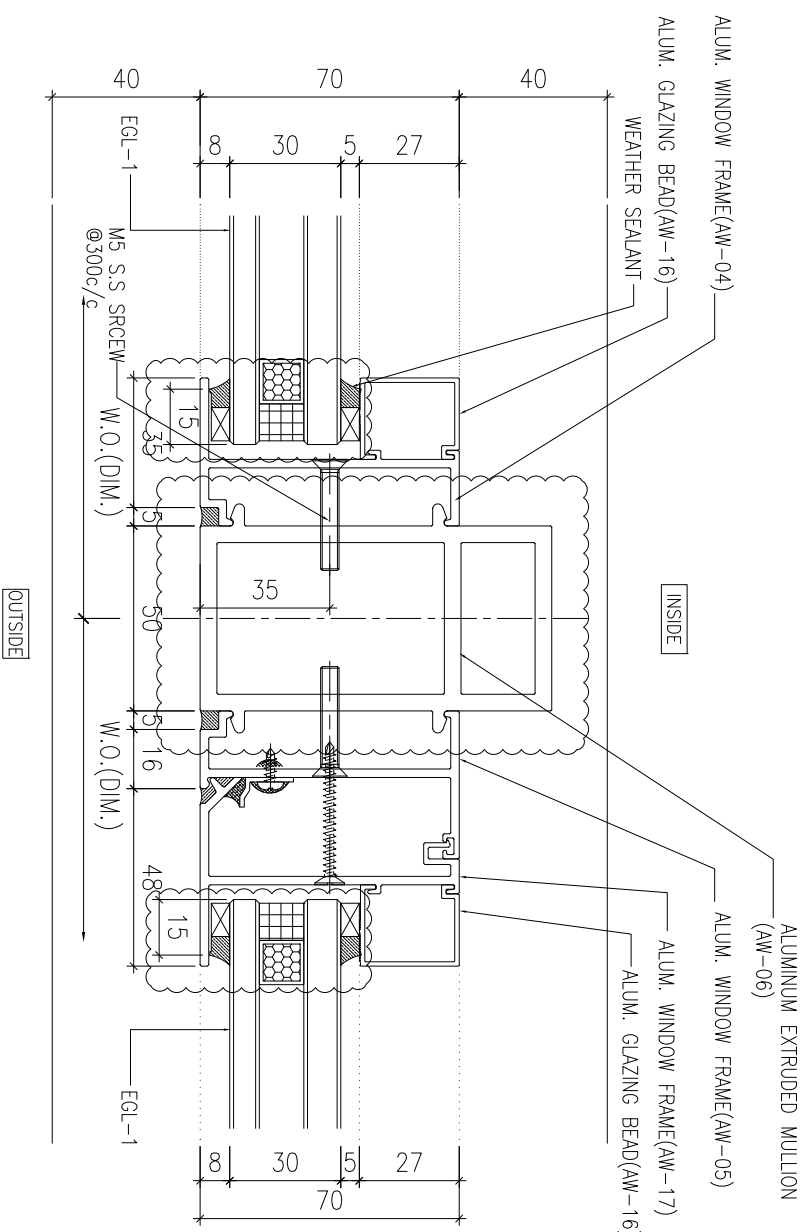

4 HORIZONTAL DETAIL  
SCALE 1:2

B.O. REF. :

CLIENT :

**SUN HUNG KAI**  
REAL ESTATE AGENCY LTD.  
42/F SUN HUNG KAI CENTRE, WINGHAI, HONGKONG

ARCHITECT :

**lw&partners**  
A R C H I T E C T S

MAIN CONTRACTOR :

**怡輝建築有限公司**  
**Yee Fai** Building Contractors Ltd.

STRUCTURAL ENGINEER :

**ARUP**  
FACADE CONSULTANT:

**ALPHA CONSULTING LIMITED**  
Steel Structure & Facade Specialist

NOTE :

1. ALL DIMENSIONS ARE IN mm.
2. ALL ELEVATIONS ARE VIEWED FROM OUTSIDE.
3. ALL DIMENSIONS TO BE VERIFIED ON SITE BEFORE FABRICATION.

LEGEND :

⊗1 --- DETAIL MARK NO.  
⊗200 --- REFER SHEET NO.

1. F.F.L. --- FINISHED FLOOR LEVEL
2. S.F.L. --- STRUCTURAL FLOOR LEVEL
3. ⊗ --- REVERSED DETAIL
4. GLASS LEGEND

EGL-1 --- 9mmH+12mm AIR GAP+10mmTP THK. LGU.  
EGL-2 --- 10mm THK. CLEAR TEMPERED GLASS  
EGL-4 --- 10mm THK. TEMPERED ACID ETCHED GLASS  
EGL-1A --- 9mmH+12mm AIR GAP+8mmTP THK. LGU.

NO.	DATE	REVISION	REVISION SUBJECT TO ARCHITECTMENT	BY
C	02/11/2021	REVISION SUBJECT TO ARCHITECTMENT		HW
B	30/10/2021	REVISION SUBJECT TO ARCHITECTMENT		HW
A	30/09/2021	REVISION SUBJECT TO ARCHITECTMENT		HW

JOB NO. : J-8556

PROJECT :

PROPOSED DEVELOPMENT ABOVE  
LIGHT RAIL TIN WING STOP TSWTL  
NO.23, AREA 33, TIN SHUI WAI, N.T.

TITLE :

TYPICAL DETAILS FOR  
ALUM. WINDOW

DATE : 02-Aug-21 SCALE : 1:40

DRAWN BY : Iwon CHECKED BY :

**美特鋁質有限公司**  
**MIDI ALUMINIUM FABRICATOR LTD.**  
Units 6-8, Sunray Industrial Centre, 1/F  
610 Cho Kwong Road, Kowloon  
Tel: 23489211-4 Fax: (852) 27277866  
DWG NO. : J856-SD-PW-DT62 REV. : C

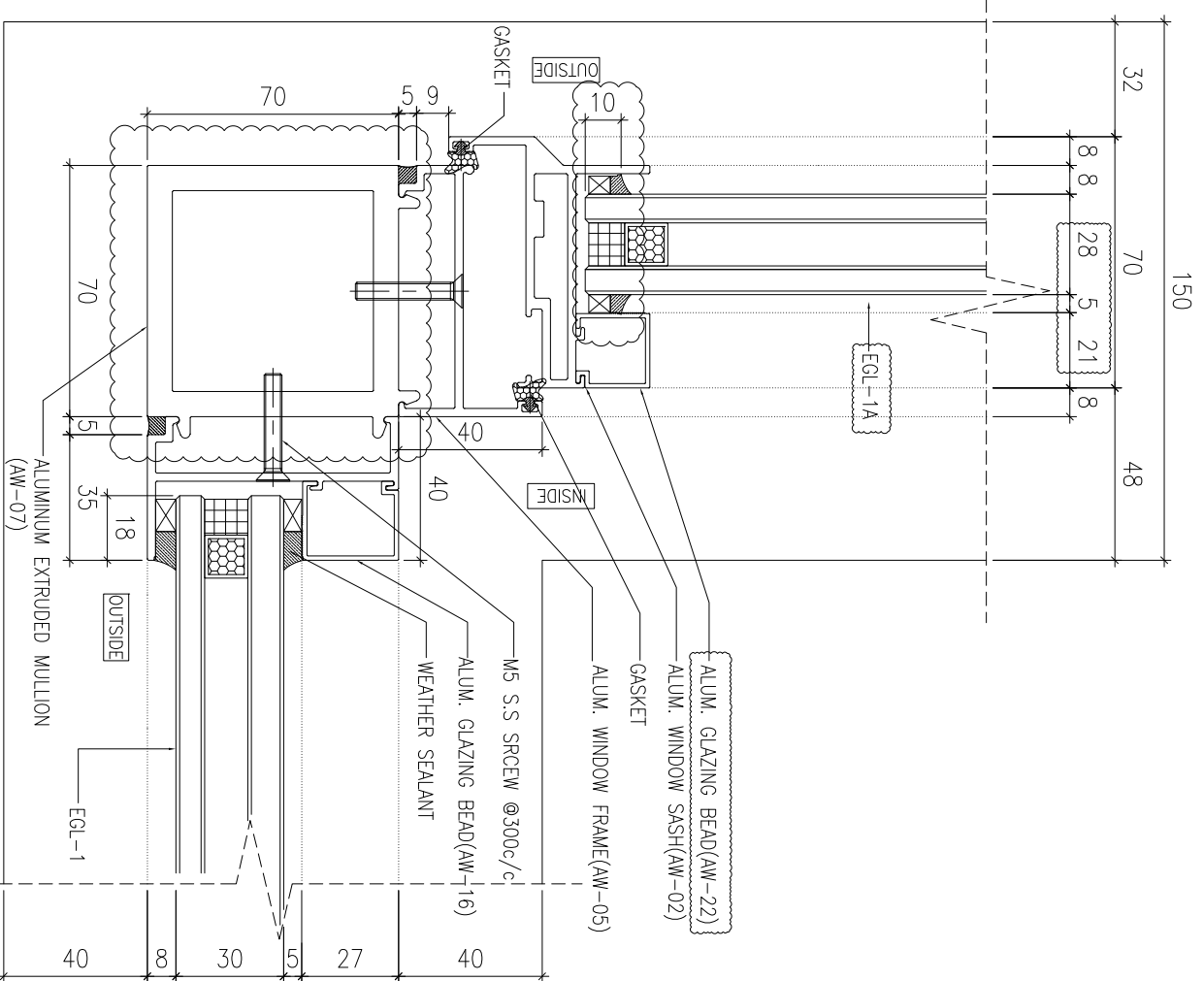

1 HORIZONTAL DETAIL  
SCALE 1:2

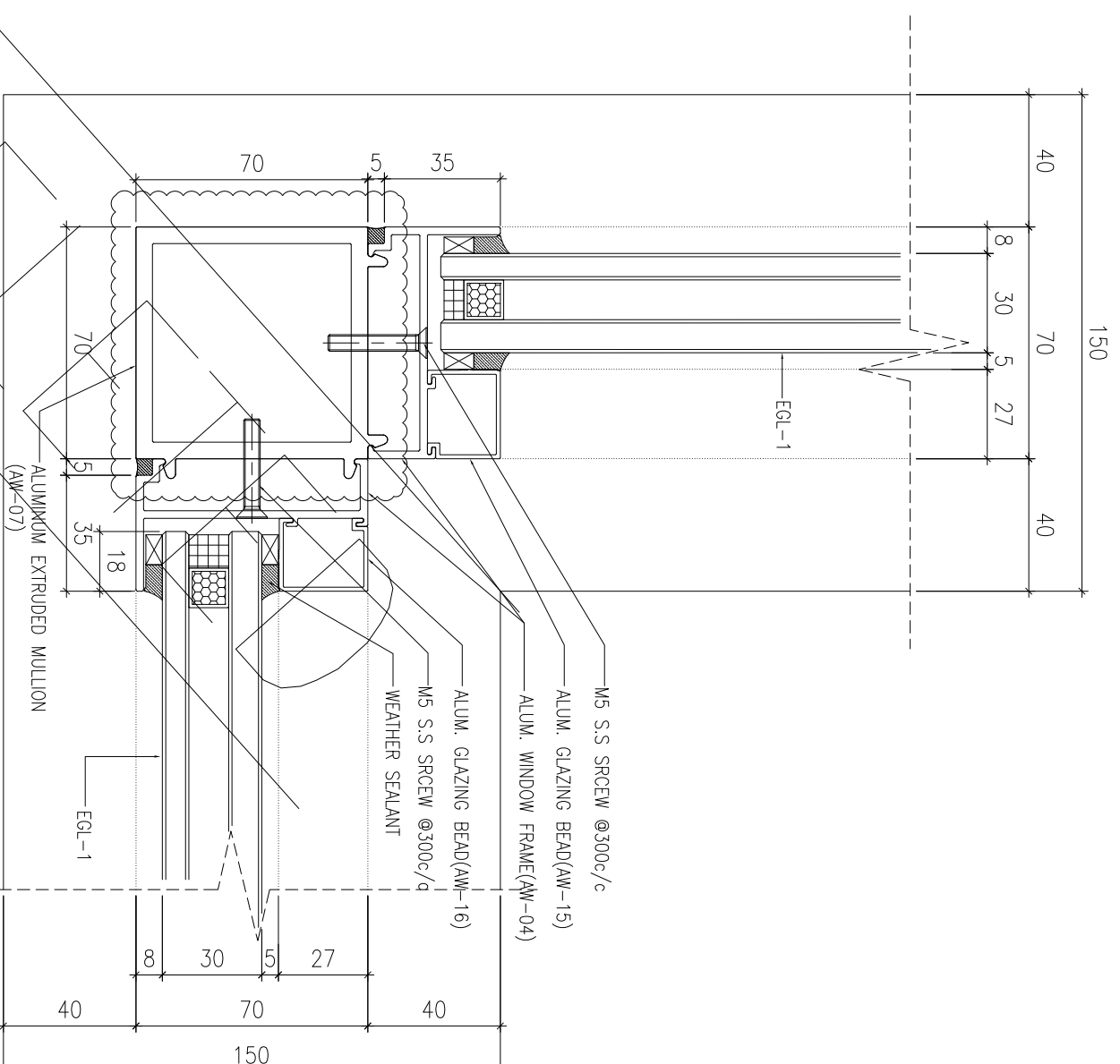

2 HORIZONTAL DETAIL  
SCALE 1:2

B.O. REF. :

CLIENT :

**SUN HUNG KAI**  
REAL ESTATE AGENCY LTD.  
42/F SUN HUNG KAI CENTRE, WANGCHAI, HONGKONG

ARCHITECT :

**lwk&partners**  
A R C H I T E C T S

MAIN CONTRACTOR :

**怡輝建築有限公司**  
**Yee Fai** Building Contractors Ltd.

STRUCTURAL ENGINEER :

**ARUP**

FAÇADE CONSULTANT :

**ALPHA CONSULTING LIMITED**  
Steel Structure & Façade Specialist

NOTE :

1. ALL DIMENSIONS ARE IN mm.
2. ALL ELEVATIONS ARE VIEWED FROM OUTSIDE.
3. ALL DIMENSIONS TO BE VERIFIED ON SITE BEFORE FABRICATION.

LEGEND :

⊗11 — DETAIL MARK NO.  
⊗001 — REFER SHEET NO.

1. F.F.L. — FINISHED FLOOR LEVEL
2. S.F.L. — STRUCTURAL FLOOR LEVEL
3. Ⓡ — REVERSED DETAIL
4. GLASS LEGEND

EGL-1 — 8mmHS+12mm AIR GAP+10mmTP THK. LG.U.  
EGL-2 — 10mm THK. CLEAR TEMPERED GLASS  
EGL-4 — 10mm THK. TEMPERED ACID ETCHED GLASS  
EGL-1A — 8mmHS+12mm AIR GAP+8mmTP THK. LG.U.

NO.	DATE	REVISION	REVISION SUBJECT TO ARCHITECTMENT	BY
C	02/11/2021	REVISION SUBJECT TO ARCHITECTMENT		WON
B	30/10/2021	REVISION SUBJECT TO ARCHITECTMENT		WON
A	30/09/2021	REVISION SUBJECT TO ARCHITECTMENT		WON

JOB NO. : J-856

PROJECT :

PROPOSED DEVELOPMENT ABOVE  
LIGHT RAIL TIN WING STOP-TSWTL  
NO.23,AREA 33,TIN SHUI WAI, N.T.

TITLE :

TYPICAL DETAILS FOR  
ALUM. WINDOW

DATE : 02-Aug-21 SCALE : 1:40

DRAWN BY : Iwon CHECKED BY :

**美特鋁質有限公司**  
**MIDI ALUMINIUM FABRICATOR LTD.**  
Units 6-8, Sunray Industrial Centre, 1/F  
610 Che Kwong Road, Kowloon  
Tel:23489211-4 Fax:(852)27277866  
DWG NO. : J856-SD-PW-DT63 REV. : C

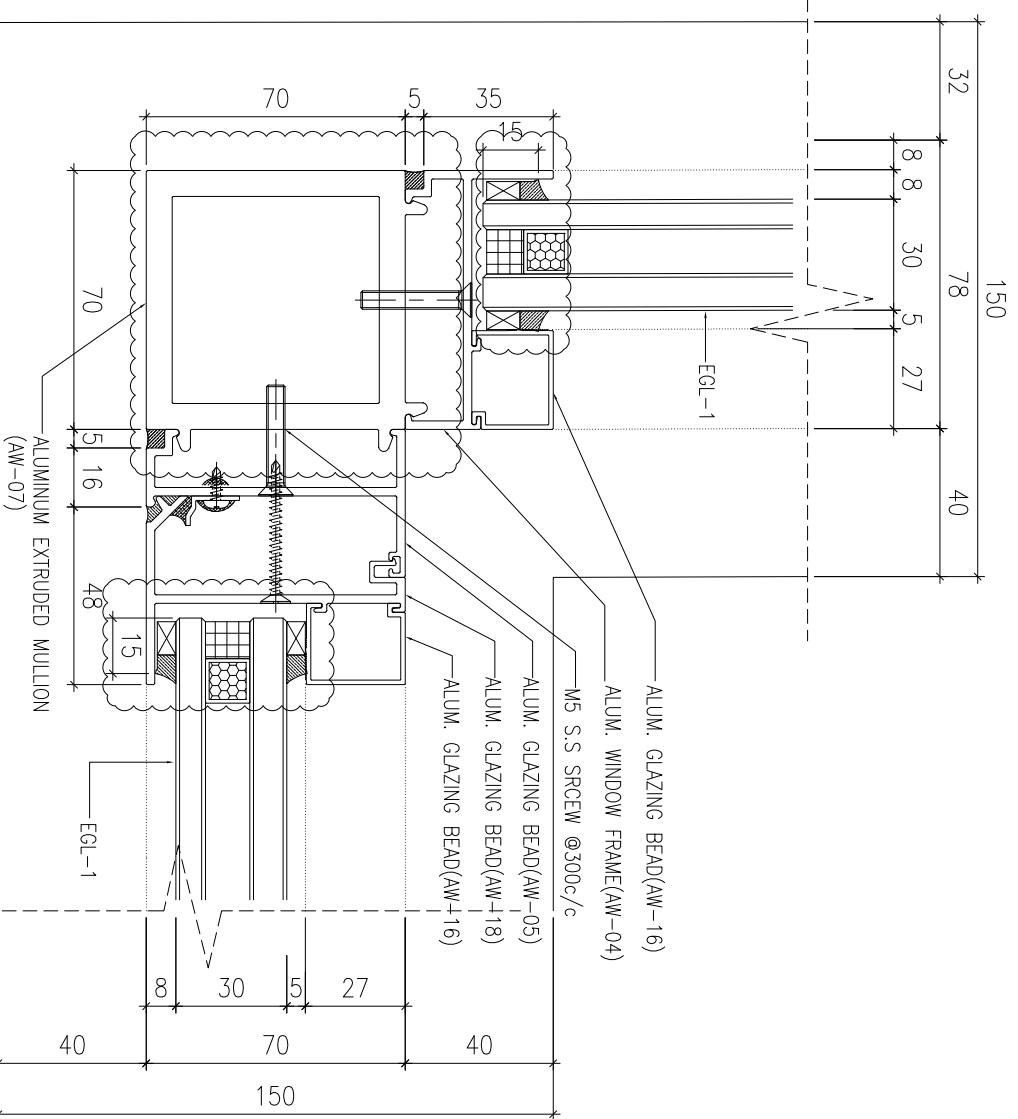

1 HORIZONTAL DETAIL  
SCALE 1:2

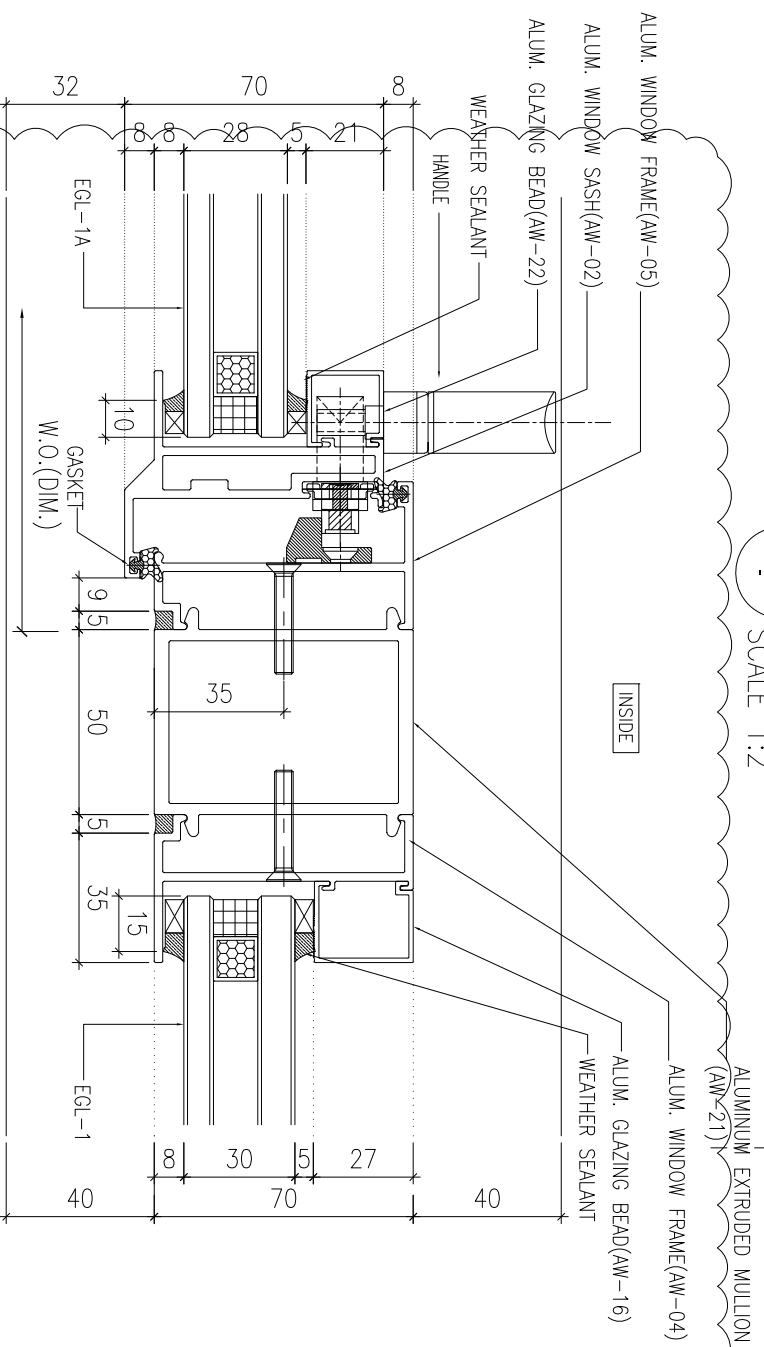

2 HORIZONTAL DETAIL  
SCALE 1:2

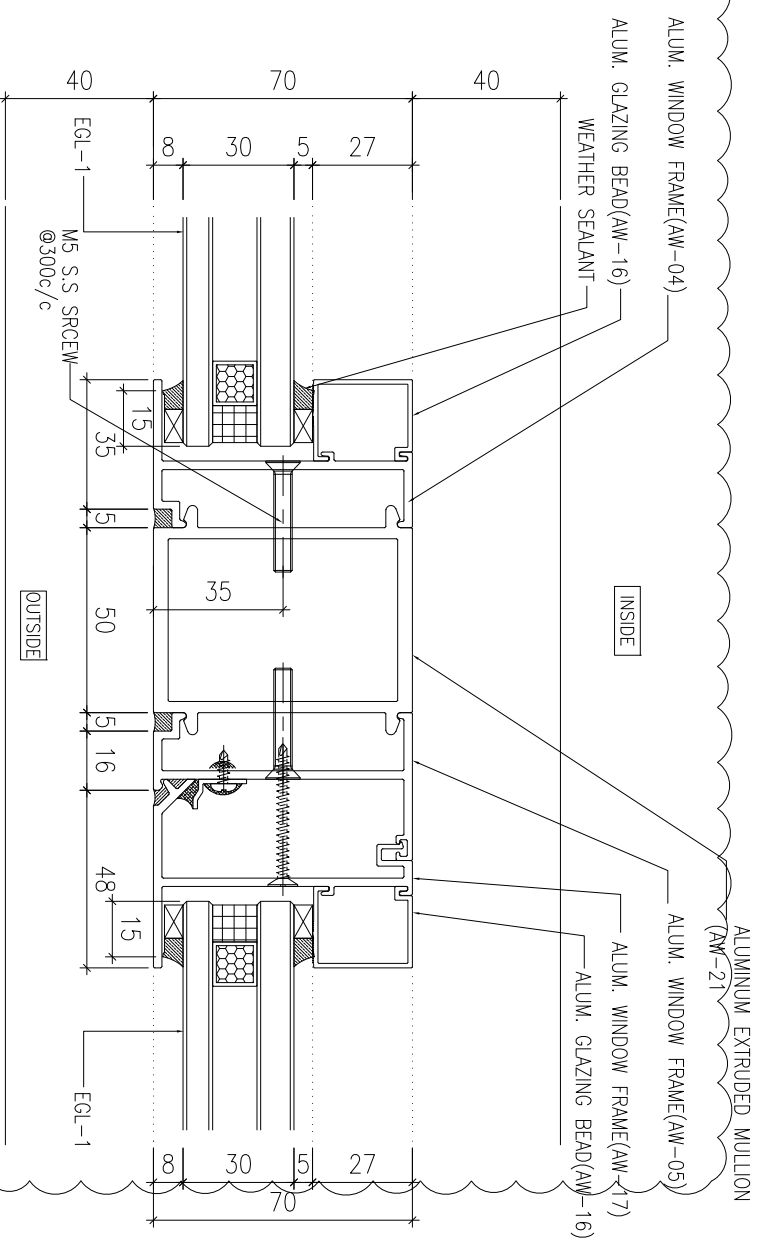

3 HORIZONTAL DETAIL  
SCALE 1:2

B.O. REF :

CLIENT :

**SUN HUNG KAI**  
REAL ESTATE AGENCY LTD.

42/F SUN HUNG KAI CENTRE, WINGHUA, HONGKONG

ARCHITECT :

**lwk&partners**  
A R C H I T E C T S

MAIN CONTRACTOR :

**怡輝建築有限公司**  
**Yee Fai** Building Contractors Ltd.

STRUCTURAL ENGINEER :

**ARUP**

FAÇADE CONSULTANT:

**ALPHA CONSULTING LIMITED**  
Steel Structure & Façade Specialist

NOTE :

1. ALL DIMENSIONS ARE IN mm.
2. ALL ELEVATIONS ARE VIEWED FROM OUTSIDE.
3. ALL DIMENSIONS TO BE VERIFIED ON SITE BEFORE FABRICATION.

LEGEND :

- ⊗11—DETAIL MARK NO.
- ⊗001—REFER SHEET NO.

1. F.F.L.--FINISHED FLOOR LEVEL
2. S.F.L.--STRUCTURAL FLOOR LEVEL
3. ⊗R--REVERSED DETAIL

4. GLASS LEGEND

- EGL-1--8mmHS+12mm AIR GAP+10mmTP THK. I.G.U.
- EGL-2--10mm THK. CLEAR TEMPERED GLASS
- EGL-4--10mm THK. TEMPERED ACID ETCHED GLASS
- EGL-1A-8mmHS+12mm AIR GAP+8mmTP THK. I.G.U.

NO.	DATE	REVISION	REVISION SUBJECT TO ARCHITECTMENT
0	02/11/2021	REVISION SUBJECT TO ARCHITECTMENT	None
C	30/10/2021	REVISION SUBJECT TO ARCHITECTMENT	None
B	18/10/2021	REVISION SUBJECT TO ARCHITECTMENT	None
A	30/09/2021	REVISION SUBJECT TO ARCHITECTMENT	None

JOB NO. : J-856

PROJECT :

PROPOSED DEVELOPMENT ABOVE  
LIGHT RAIL TIN WING STOP TSWTL  
NO.23,AREA 33,TIN SHUI WAI, N.T.

TITLE :

TYPICAL DETAILS FOR  
ALUM. WINDOW

DATE : 02-Aug-21 SCALE : 1:40

DRAWN BY : Ivon CHECKED BY :

**美特鋁業有限公司**  
**MIDI ALUMINIUM FABRICATOR LTD.**  
Units 6-8, Sunray Industrial Centre, 1/F  
610 Chee Kwong Road, Kowloon  
Tel:23489211-4 Fax:(852)27277866  
DWG NO. : J856-SD-PW-D164 REV. : D

CLIENT :

**SUN HUNG KAI**  
**REAL ESTATE AGENCY LTD.**  
 42/F SUN HUNG KAI CENTRE, WINGHUA, HONGKONG

ARCHITECT :

**lwk&partners**  
 a r c h i t e c t s

MAIN CONTRACTOR :

**怡輝建築有限公司**  
**Yee Fai Building Contractors Ltd.**

STRUCTURAL ENGINEER :

**ARUP**

FAÇADE CONSULTANT:

**ALPHA CONSULTING LIMITED**  
 Steel Structure & Façade Specialist

NOTE :

1. ALL DIMENSIONS ARE IN mm.
2. ALL ELEVATIONS ARE VIEWED FROM OUTSIDE.
3. ALL DIMENSIONS TO BE VERIFIED ON SITE BEFORE FABRICATION.

LEGEND :

- ⊗1--- DETAIL MARK NO.
- ⊗001--- REFER SHEET NO.

1. F.F.L.--FINISHED FLOOR LEVEL
2. S.F.L.--STRUCTURAL FLOOR LEVEL
3. ⊗R---REVERSED DETAIL

4. GLASS LEGEND

- EGL-1--8mmHS+12mm AIR GAP+10mmTP THK. I.G.U.
- EGL-2--10mm THK. CLEAR TEMPERED GLASS
- EGL-4--10mm THK. TEMPERED ACID ETCHED GLASS
- EGL-1A--8mmHS+12mm AIR GAP+8mmTP THK. I.G.U.

NO.	DATE	REVISION	REVISION SUBJECT TO ARCHITECTMENT	BY
B	02/11/2021	REVISION SUBJECT TO ARCHITECTMENT		HW
A	30/10/2021	REVISION SUBJECT TO ARCHITECTMENT		HW

JOB NO. : J-856

PROJECT :  
 PROPOSED DEVELOPMENT ABOVE  
 LIGHT RAIL TIN WING STOP TSWTL  
 NO.23,AREA 33,TIN SHUI WAI, N.T.

TITLE :  
 TYPICAL DETAILS FOR  
 ALUM. WINDOW

DATE : 02-Aug-21 SCALE : 1:40

DRAWN BY : Iwon CHECKED BY :

**美特鋁質有限公司**  
**MIDI ALUMINIUM FABRICATOR LTD.**  
 Units 6-8, Sunray Industrial Centre, 1/F  
 610 Ona Kwong Road, Kowloon  
 Tel:23489211-4 Fax:(852)27277866  
 DWG NO. : J856-SD-PW-D171 REV. : B

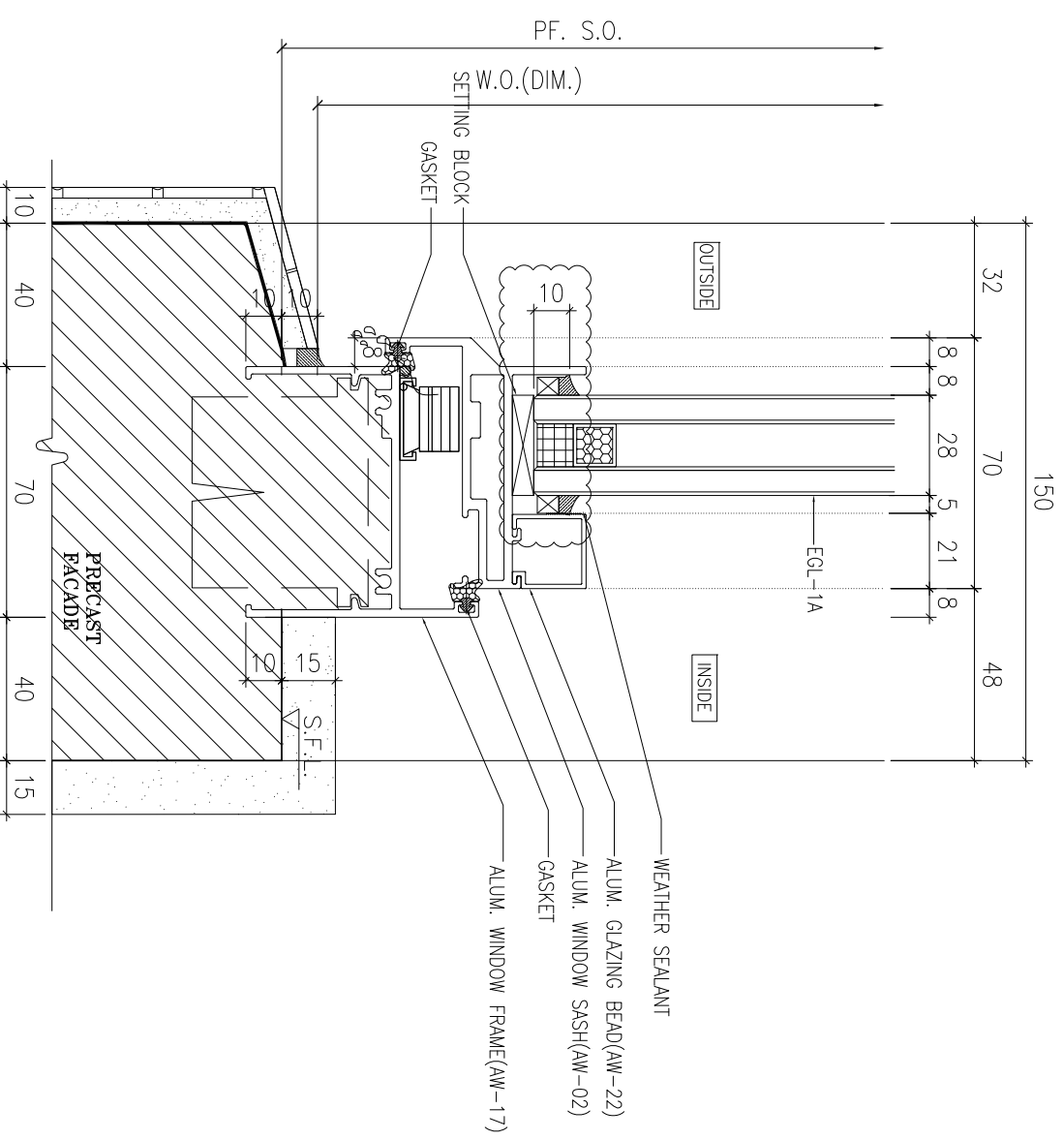
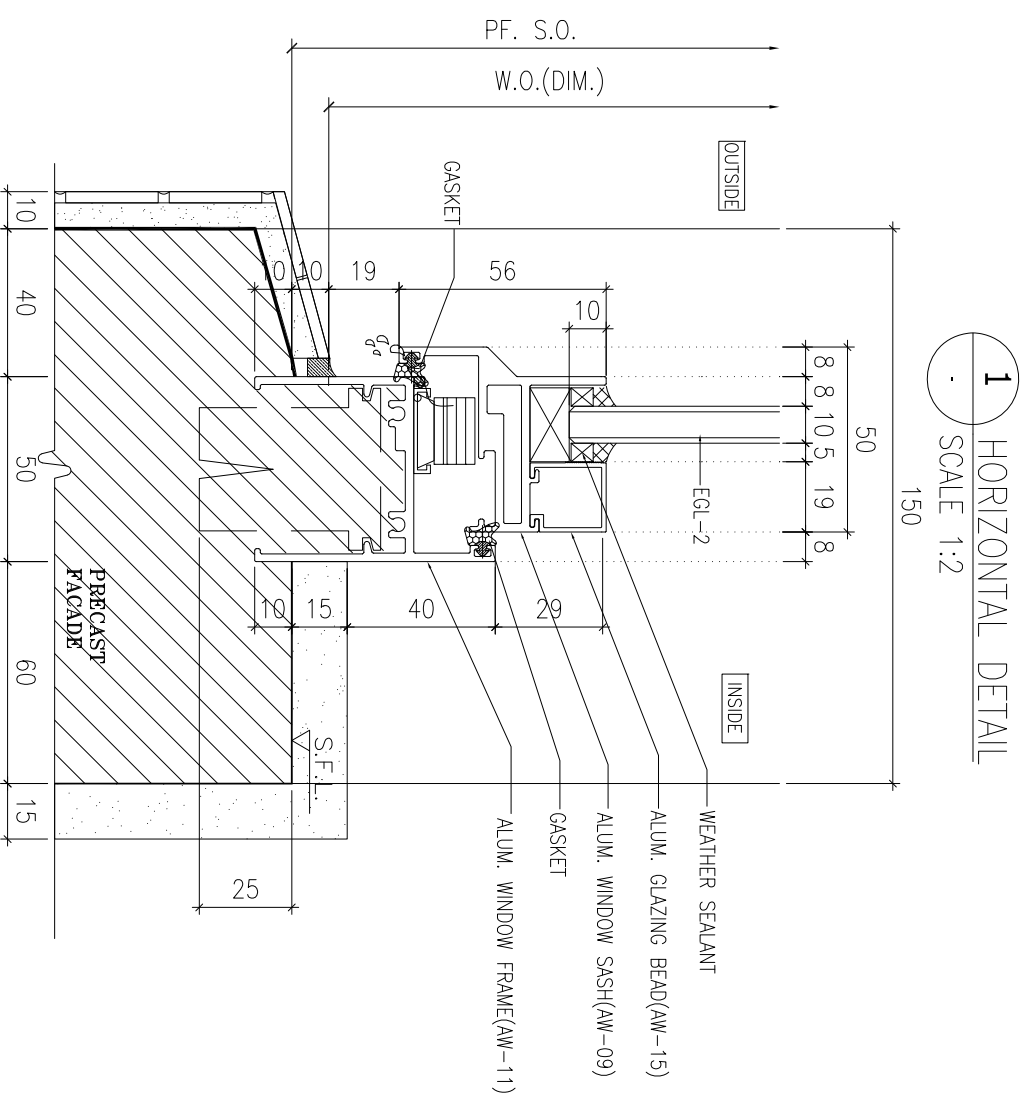
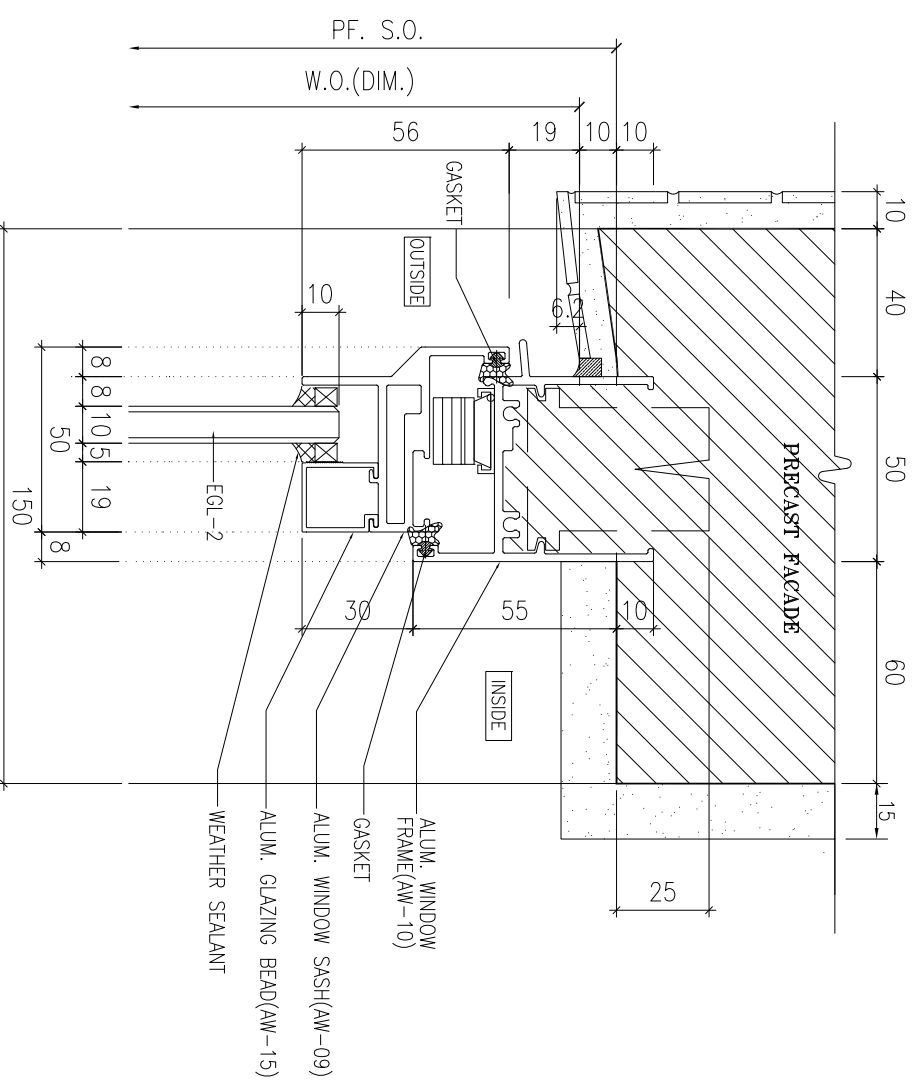



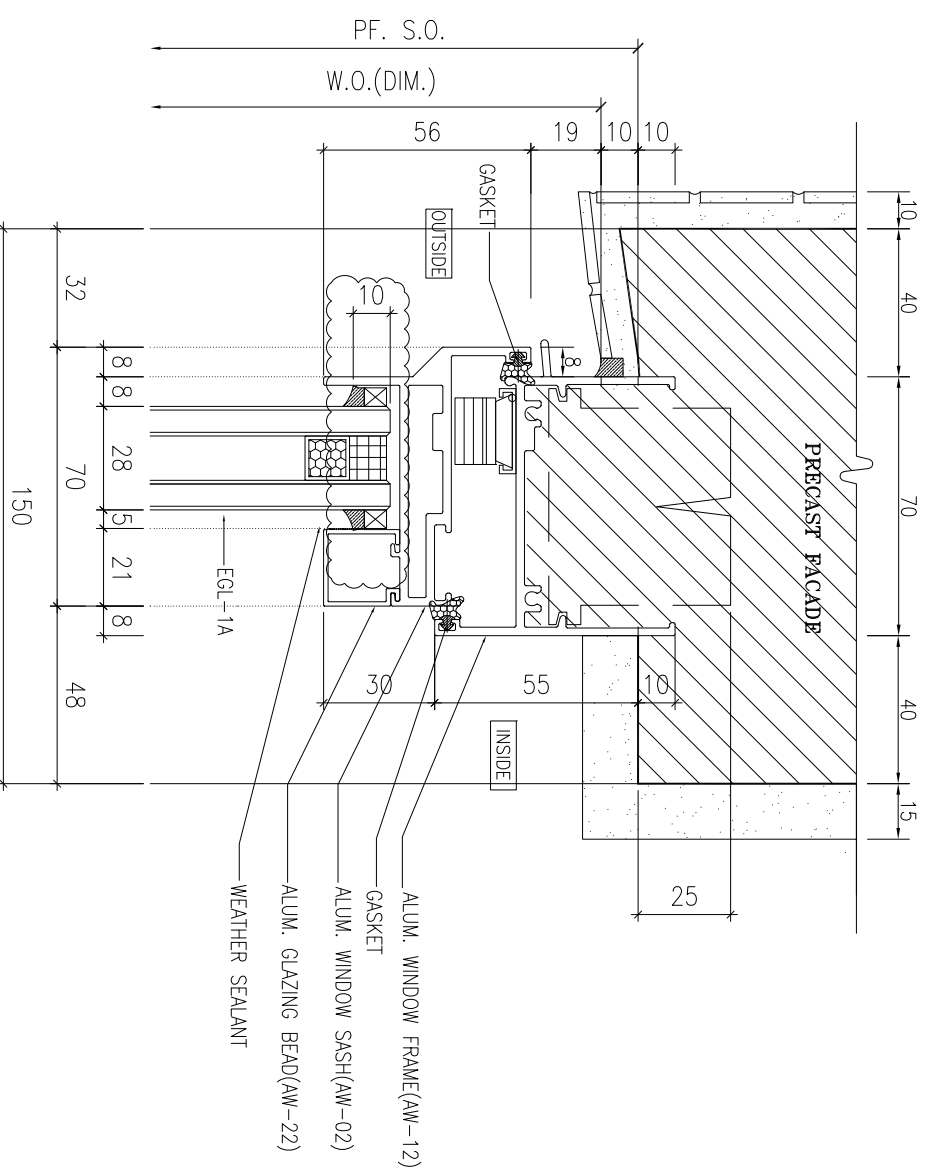

1 HORIZONTAL DETAIL  
SCALE 1:2

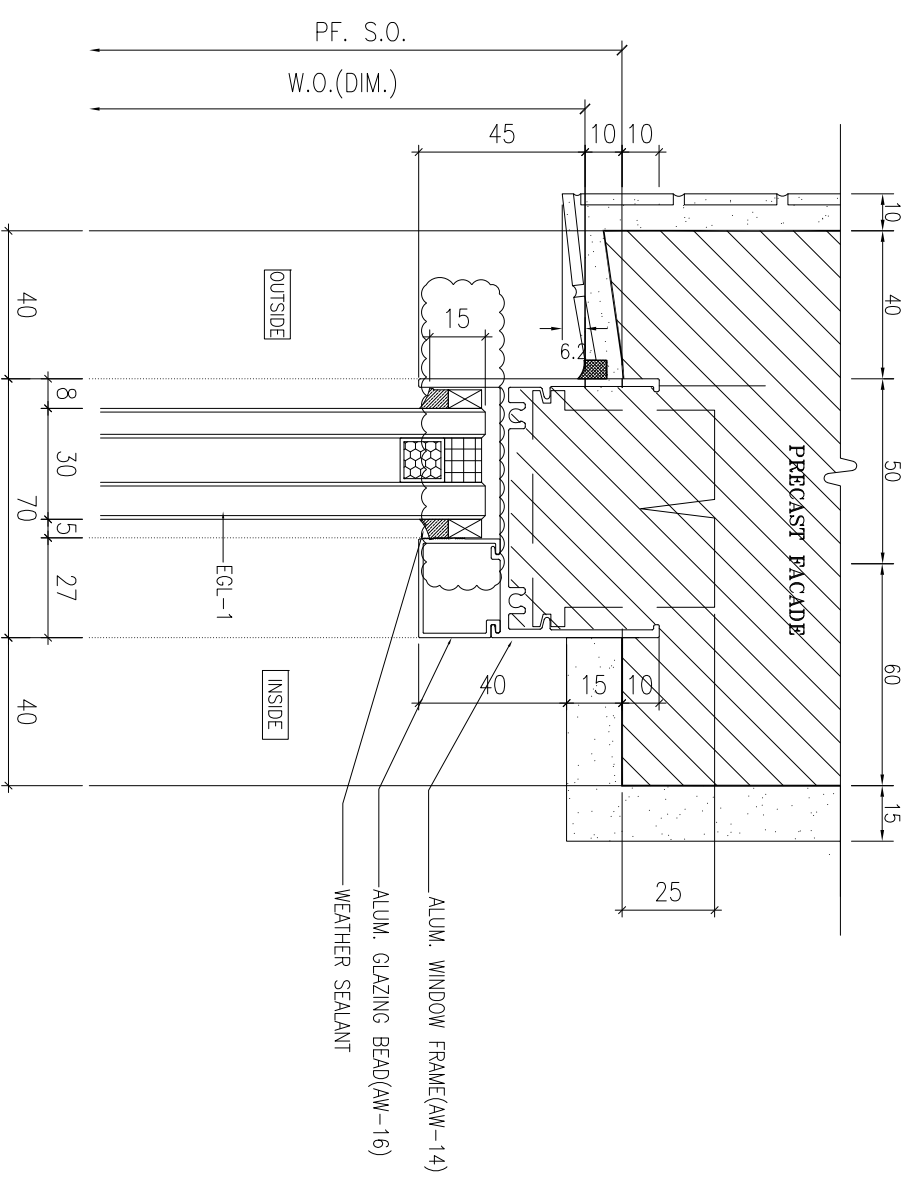

3 HORIZONTAL DETAIL  
SCALE 1:2

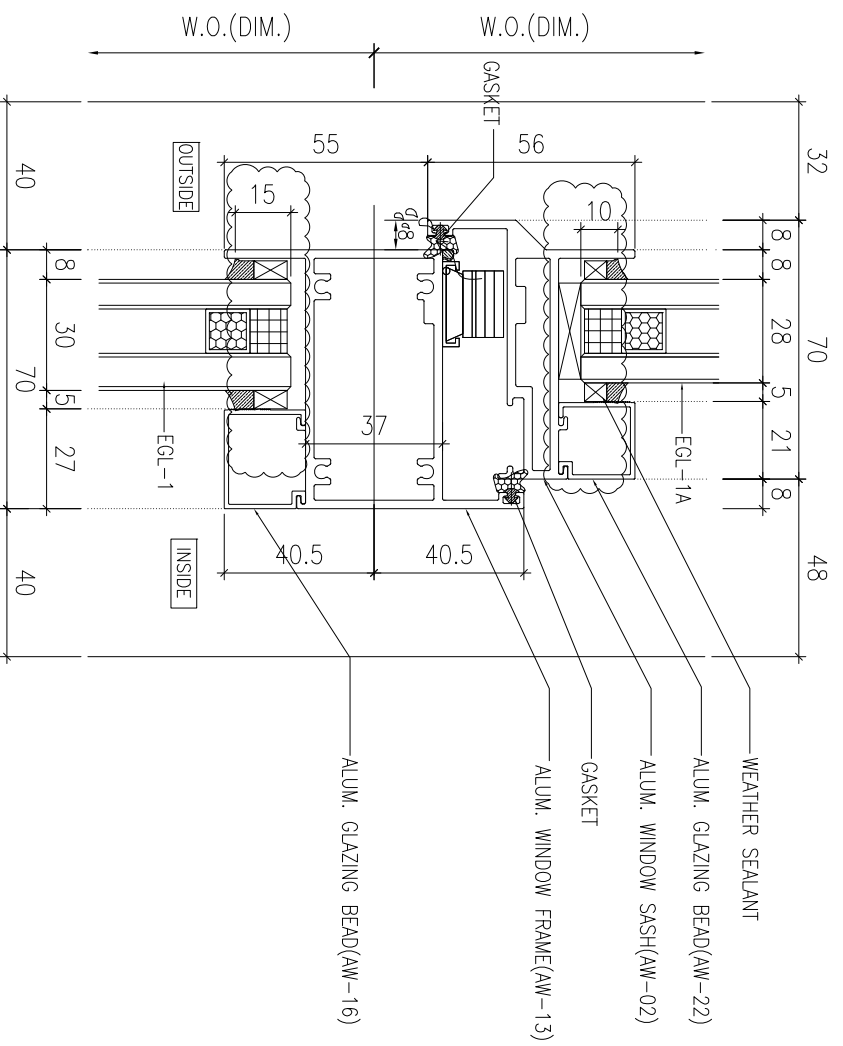

2 HORIZONTAL DETAIL  
SCALE 1:2

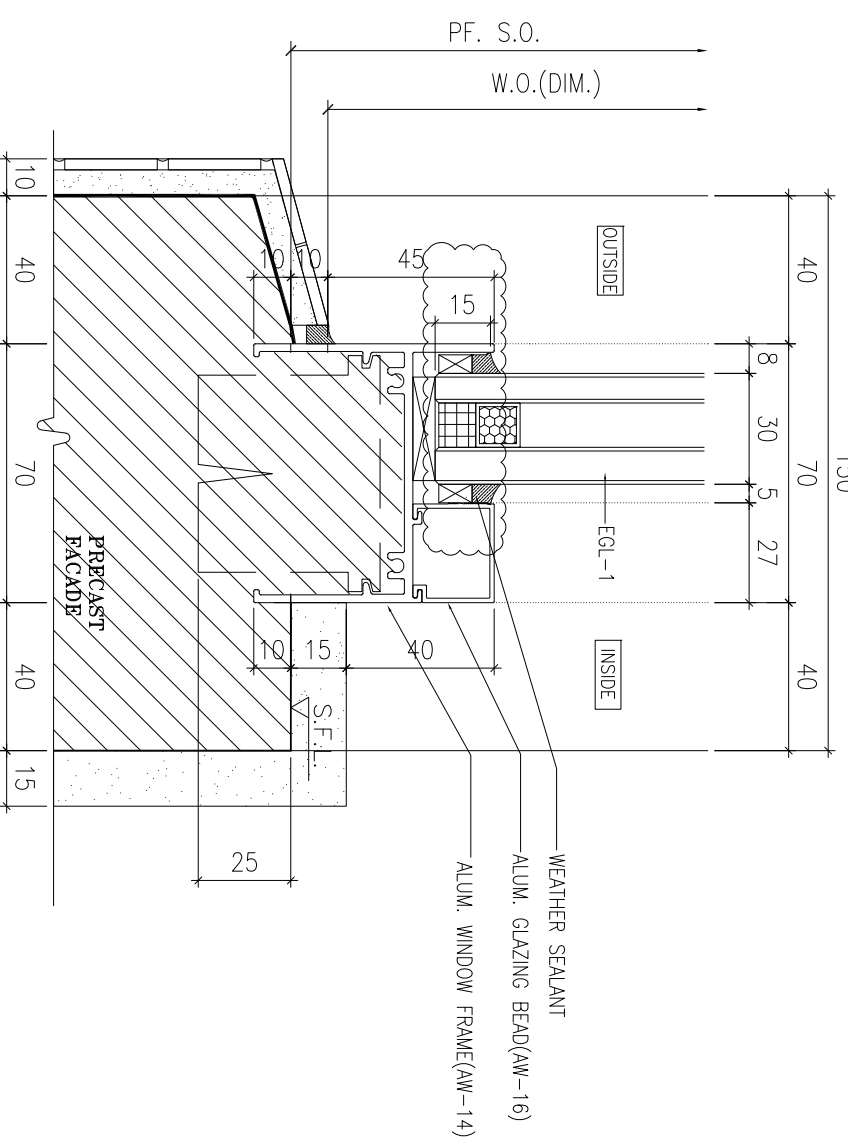

4 HORIZONTAL DETAIL  
SCALE 1:2

B.O. REF :

CLIENT :

**SUN HUNG KAI**  
REAL ESTATE AGENCY LTD.  
42/F SUN HUNG KAI CENTRE, WINGLOH, HONGKONG

ARCHITECT :

**IWK&partners**  
A R C H I T E C T S

MAIN CONTRACTOR :

**Yee Fai** 怡輝建築有限公司  
Building Contractors Ltd.

STRUCTURAL ENGINEER :

**ARUP**

FAÇADE CONSULTANT:

**ALPHA CONSULTING LIMITED**  
Steel Structure & Façade Specialist

NOTE :

1. ALL DIMENSIONS ARE IN mm.
2. ALL ELEVATIONS ARE VIEWED FROM OUTSIDE.
3. ALL DIMENSIONS TO BE VERIFIED ON SITE BEFORE FABRICATION.

LEGEND :

⊗11 — DETAIL MARK NO.  
X001 — REFER SHEET NO.

1. F.F.L. -- FINISHED FLOOR LEVEL
2. S.F.L. -- STRUCTURAL FLOOR LEVEL
3. Ⓡ -- REVERSED DETAIL
4. GLASS LEGEND

EGL-1 -- 8mmHS+12mm AIR GAP+10mmTP THK. I.G.U.  
EGL-2 -- 10mm THK. CLEAR TEMPERED GLASS  
EGL-4 -- 10mm THK. TEMPERED ACID ETCHED GLASS  
EGL-1A -- 8mmHS+12mm AIR GAP+8mmTP THK. I.G.U.

NO.	DATE	REVISION	SUBJECT TO ARCHITECTMENT	BY
B	02/11/2021	REVISION SUBJECT TO ARCHITECTMENT		
A	30/10/2021	REVISION SUBJECT TO ARCHITECTMENT		

JOB NO. : J-856

PROJECT : PROPOSED DEVELOPMENT ABOVE LIGHT RAIL TIN WING STOP TSWTL NO.23, AREA 33, TIN SHUI WAI, N.T.

TITLE : TYPICAL DETAILS FOR ALUM. WINDOW

DATE : 02-Aug-21 SCALE : 1:40

DRAWN BY : Ivon CHECKED BY :

**MIDI** 美特鋁質有限公司  
ALUMINIUM FABRICATOR LTD.  
Units 6-8, Sunray Industrial Centre, 1/F  
610 Ona Kwo Ling Road, Kowloon  
Tel:23489211-4 Fax:(852)27277866  
DWG NO. : J856-SD-PW-D172 REV. : B

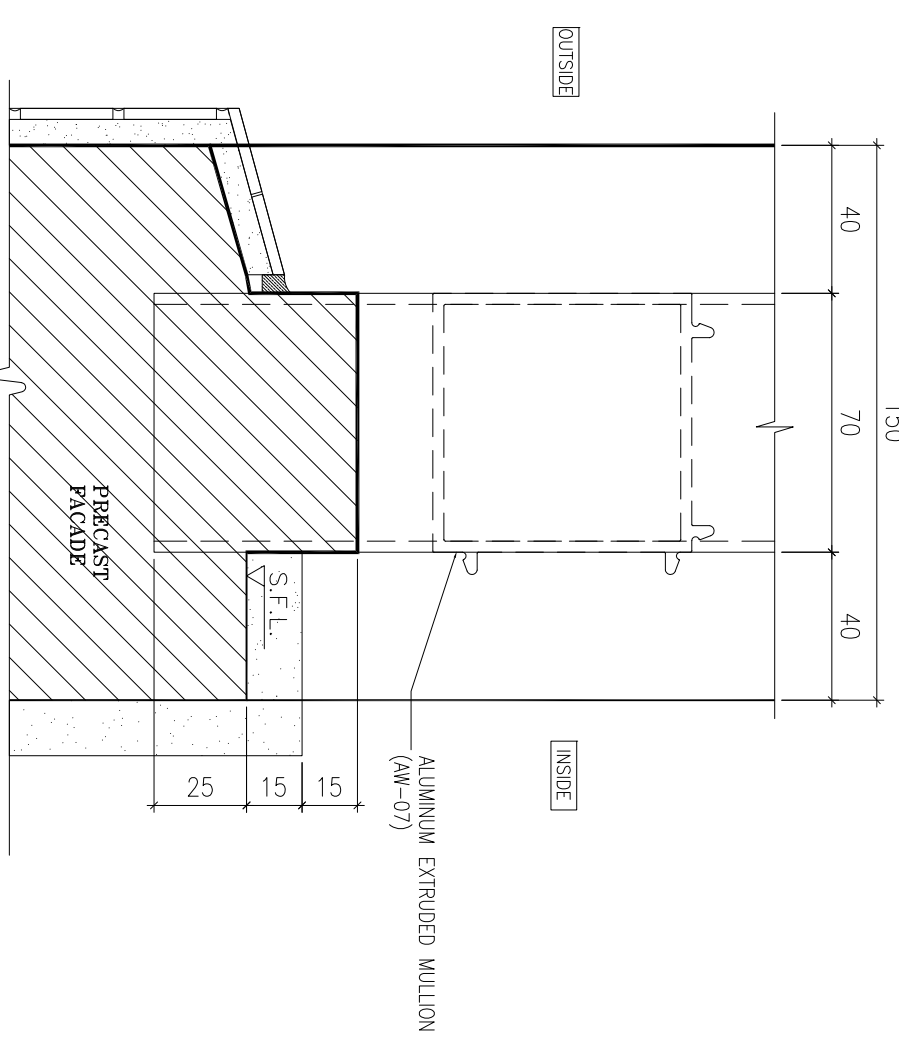
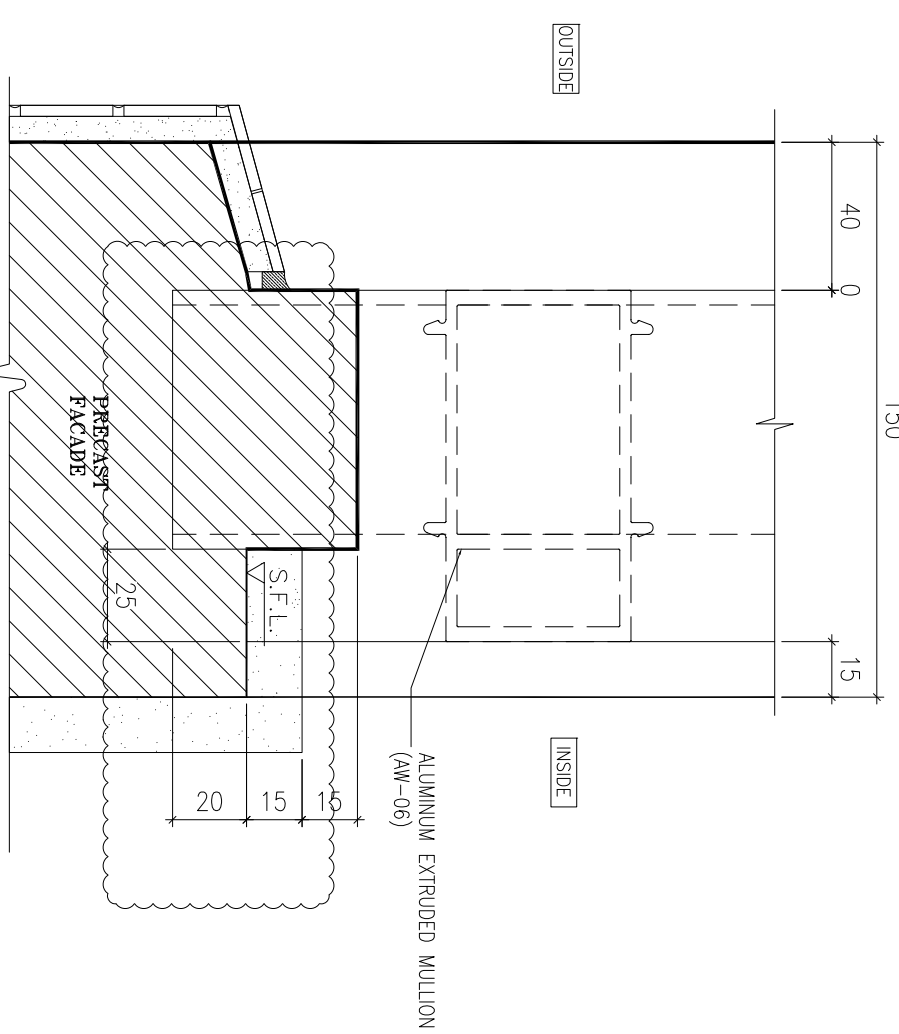
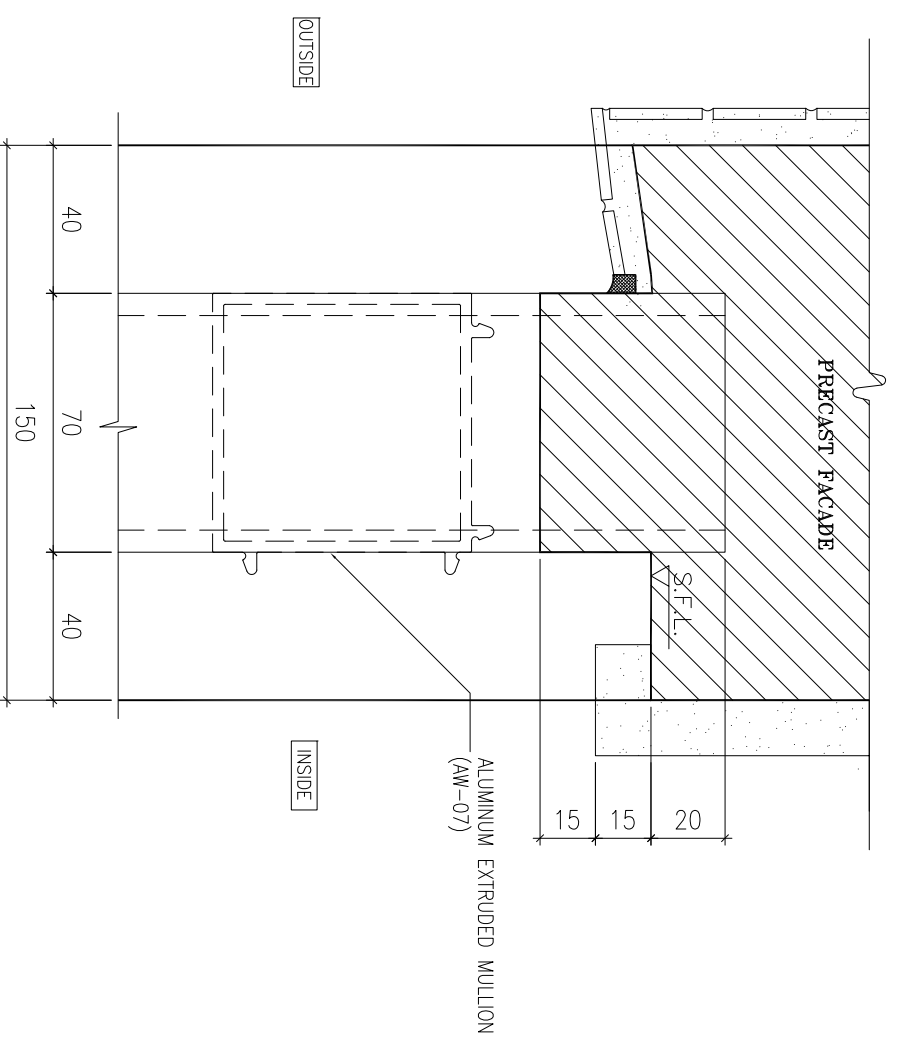
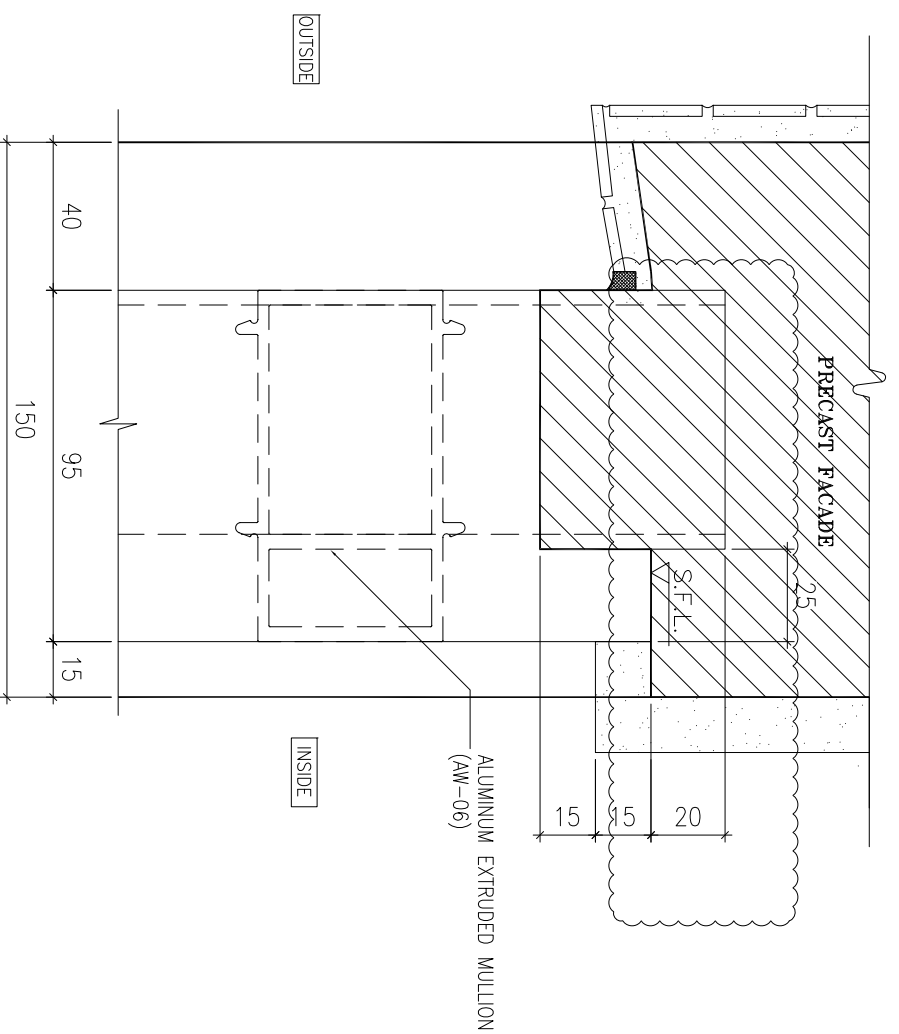

B.O. REF :

CLIENT :

**SUN HUNG KAI**  
REAL ESTATE AGENCY LTD.

42/F SUN HUNG KAI CENTRE, WINGHUA, HONGKONG

ARCHITECT :

**lwk&partners**  
A R C H I T E C T S

MAIN CONTRACTOR :

**怡輝建築有限公司**  
Yee Fai Building Contractors Ltd.

STRUCTURAL ENGINEER :

**ARUP**  
ALPHA CONSULTING LIMITED  
Steel Structure & Facade Specialist

FAÇADE CONSULTANT:

**α** ALPHA CONSULTING LIMITED  
Steel Structure & Facade Specialist

NOTE :

1. ALL DIMENSIONS ARE IN mm.
2. ALL ELEVATIONS ARE VIEWED FROM OUTSIDE.
3. ALL DIMENSIONS TO BE VERIFIED ON SITE BEFORE FABRICATION.

LEGEND :

⊗1—DETAIL MARK NO.  
⊗201—REFER SHEET NO.

1. F.F.L.--FINISHED FLOOR LEVEL
2. S.F.L.--STRUCTURAL FLOOR LEVEL
3. ⊗R--REVERSED DETAIL

4. GLASS LEGEND

EQ-1--8mmHS+12mm AIR GAP+10mmTP THK. I.G.U.  
EQ-2--10mm THK. CLEAR TEMPERED GLASS  
EQ-4--10mm THK. TEMPERED ACID ETCHED GLASS  
EQ-1A--8mmHS+12mm AIR GAP+8mmTP THK. I.G.U.

NO.	DATE	REVISION	REVISION SUBJECT TO ARCHITECTMENT	BY
C	02/11/2021	REVISION SUBJECT TO ARCHITECTMENT	None	
B	30/10/2021	REVISION SUBJECT TO ARCHITECTMENT	None	
A	30/09/2021	REVISION SUBJECT TO ARCHITECTMENT	None	

JOB NO. : J-856

PROJECT : PROPOSED DEVELOPMENT ABOVE LIGHT RAIL TIN WING STOP TSWTL NO.23,AREA 33,TIN SHUI WAI, N.T.

TITLE : TYPICAL DETAILS FOR ALUM. WINDOW

DATE : 02-Aug-21 SCALE : 1:40

DRAWN BY : Ivon CHECKED BY :

**美特鋁質有限公司**  
MIDI ALUMINIUM FABRICATOR LTD.  
Units 6-8, Sunray Industrial Centre, 1/F  
610 Ona Kwong Road, Kowloon  
Tel:23489211-4 Fax:(852)27277866  
DWG NO. : J856-SD-PW-D173 REV. : C

PRECAST FACADE

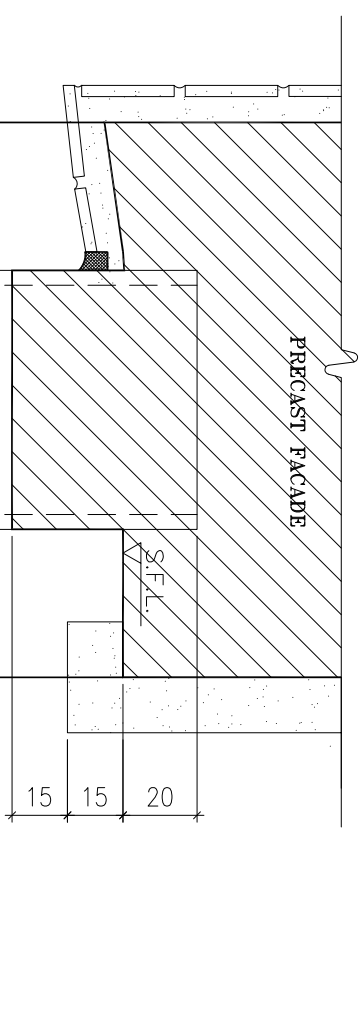
ALUMINUM EXTRUDED MULLION  
(AW-21)

OUTSIDE

INSIDE

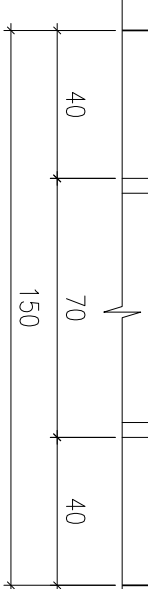
1 HORIZONTAL DETAIL  
SCALE 1:2

150

40

70

40

OUTSIDE

INSIDE

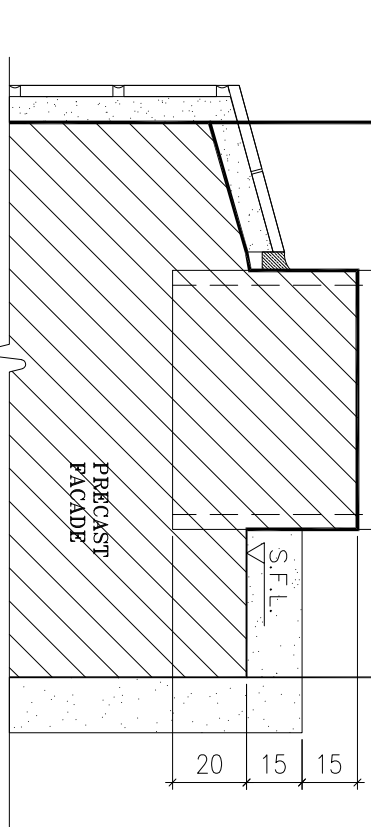
ALUMINUM EXTRUDED MULLION  
(AW-21)PRECAST  
FACADE

S.F.L.

20

15

15

2 HORIZONTAL DETAIL  
SCALE 1:2

CLIENT :

42/F SUN HUNG KAI CENTRE, WANGCHAI, HONGKONG

ARCHITECT :

MAIN CONTRACTOR :

STRUCTURAL ENGINEER :

FACADE CONSULTANT:

Steel Structure &amp; Facade Specialist

NOTE :

1. ALL DIMENSIONS ARE IN mm.
2. ALL ELEVATIONS ARE VIEWED FROM OUTSIDE.
3. ALL DIMENSIONS TO BE VERIFIED ON SITE BEFORE FABRICATION.

LEGEND :

DETAIL MARK NO.

REFER SHEET NO.

1. F.F.L.--FINISHED FLOOR LEVEL

2. S.F.L.--STRUCTURAL FLOOR LEVEL

3. --REVERSED DETAIL

4. GLASS LEGEND

EGL-1--8mmHS+12mm AIR GAP+10mmTP THK. LG.U.

EGL-2--10mm THK. CLEAR TEMPERED GLASS

EGL-4--10mm THK. TEMPERED ACID ETCHED GLASS

EGL-1A-8mmHS+12mm AIR GAP+8mmTP THK. LG.U.

NO.	DATE	REVISION	BY

JOB NO. : J-856

PROJECT :  
PROPOSED DEVELOPMENT ABOVE  
LIGHT RAIL TIN WING STOP TSWTL  
NO.23,AREA 33,TIN SHUI WAI, N.T.TITLE :  
TYPICAL DETAILS FOR

ALUM. WINDOW

DATE : 02-Aug-21 SCALE : 1:40

DRAWN BY : Iwon CHECKED BY :

Units 6-8, Sunray Industrial Centre, 1/F  
610 Chee Kwong Road, Kowloon  
Tel:23489211-4 Fax:(852)27277866

DWG NO. : J856-SD-PW-D173g REV. : -

CLIENT :

**SUN HUNG KAI**  
REAL ESTATE AGENCY LTD.

42/F SUN HUNG KAI CENTRE, WANGCHAI, HONGKONG

ARCHITECT :

**lwk&partners**  
a r c h i t e c t s

MAIN CONTRACTOR :

**怡輝建築有限公司**  
**Yee Fai** Building Contractors Ltd.

STRUCTURAL ENGINEER :

**ARUP**

FACADE CONSULTANT:

**ALPHA CONSULTING LIMITED**  
Steel Structure & Facade Specialist

NOTE:

1. ALL DIMENSIONS ARE IN mm.
2. ALL ELEVATIONS ARE VIEWED FROM OUTSIDE.
3. ALL DIMENSIONS TO BE VERIFIED ON SITE BEFORE FABRICATION.

LEGEND:

⊗11—DETAIL MARK NO.  
⊗001—REFER SHEET NO.

1. F.F.L.--FINISHED FLOOR LEVEL
2. S.F.L.--STRUCTURAL FLOOR LEVEL
3. Ⓡ--REVERSED DETAIL

4. GLASS LEGEND

EQ-1-1--8mmHS+12mm AIR GAP+10mmTP THK. LG.U.  
EQ-2-2--10mm THK. CLEAR TEMPERED GLASS  
EQ-4-4--10mm THK. TEMPERED ACID ETCHED GLASS  
EQ-1A-8mmHS+12mm AIR GAP+8mmTP THK. LG.U.

NO.	DATE	REVISION	BY

JOB NO. : J-856

PROJECT :

PROPOSED DEVELOPMENT ABOVE  
LIGHT RAIL TIN WING STOP TSWTL  
NO.23,AREA 33,TIN SHUI WAI, N.T.

TITLE :

ALUM. WINDOW SECTION  
TYPICAL LOCK & HINGES DETAIL

DATE : 02-Aug-21 SCALE : 1:40

DRAWN BY : Iwon CHECKED BY :

**美特鋁質有限公司**  
**MIDI ALUMINIUM FABRICATOR LTD.**  
Units 6-8, Sunray Industrial Centre, 1/F  
610 Ona Kwong Road, Kowloon  
Tel:23489211-4 Fax:(852)2727866

DWG NO. : J856-SD-PW-D174 REV. : -

# 70窗

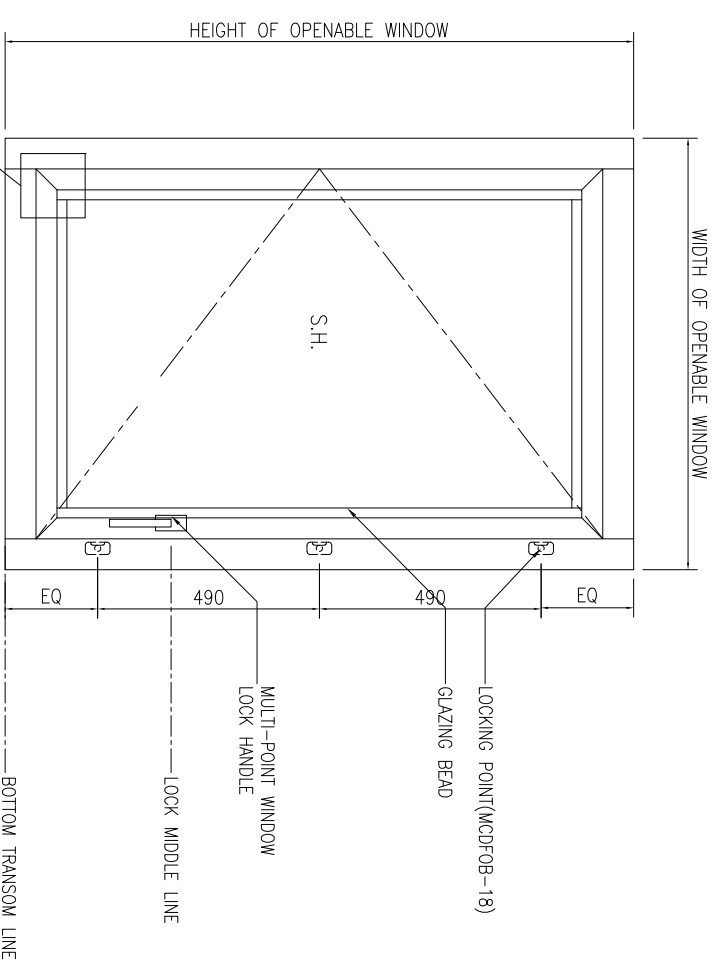
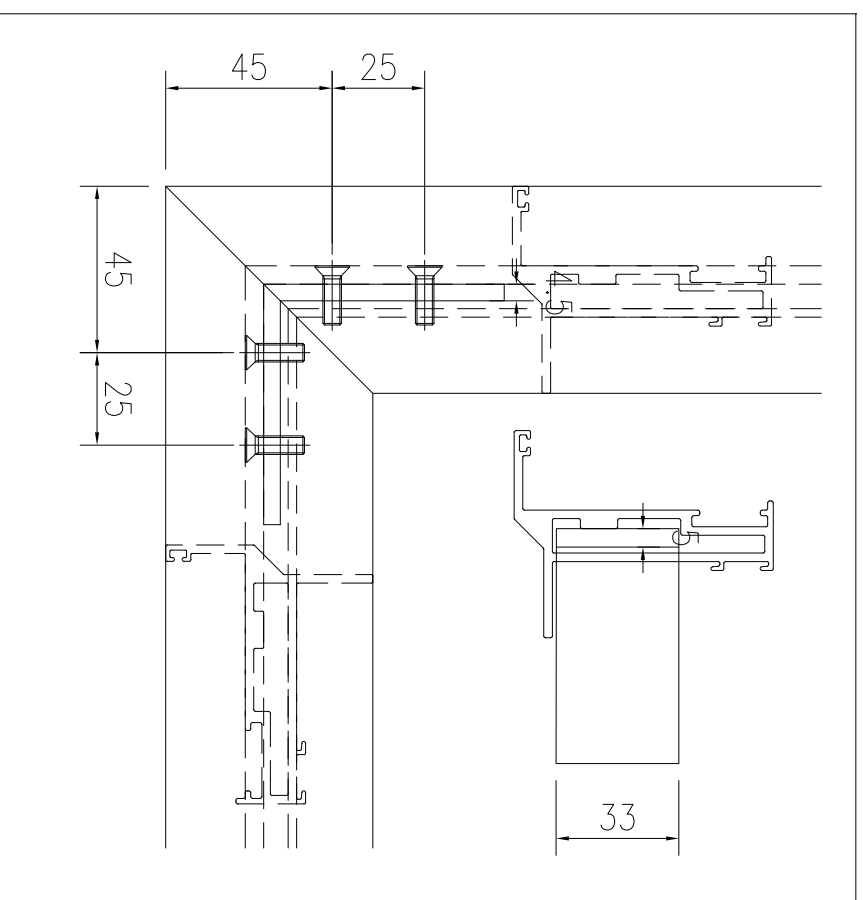

Ⓢ1  
TYPICAL SECTION

S.F.L.

B.O. REF :

CLIENT :

**SUN HUNG KAI**  
REAL ESTATE AGENCY LTD.

42/F SUN HUNG KAI CENTRE, WANGCHAI, HONGKONG

ARCHITECT :

**lwk&partners**  
a r c h i t e c t s

MAIN CONTRACTOR :

**怡輝建築有限公司**  
Yee Fai Building Contractors Ltd.

STRUCTURAL ENGINEER :

**ARUP**

FAÇADE CONSULTANT:

**ALPHA CONSULTING LIMITED**  
Steel Structure & Façade Specialist

NOTE:

1. ALL DIMENSIONS ARE IN mm.
2. ALL ELEVATIONS ARE VIEWED FROM OUTSIDE.
3. ALL DIMENSIONS TO BE VERIFIED ON SITE BEFORE FABRICATION.

LEGEND:

⊗11--- DETAIL MARK NO.  
⊗001--- REFER SHEET NO.

1. F.F.L.--FINISHED FLOOR LEVEL
2. S.F.L.--STRUCTURAL FLOOR LEVEL
3. Ⓢ---REVERSED DETAIL

4. GLASS LEGEND

EQ-1-1--8mmHS+12mm AIR GAP+10mmTP THK. LG.U.  
 EQ-2-2--10mm THK. CLEAR TEMPERED GLASS  
 EQ-4-4--10mm THK. TEMPERED ACID ETCHED GLASS  
 EQ-1A-8mmHS+12mm AIR GAP+8mmTP THK. LG.U.

NO.	DATE	REVISION	BY

JOB NO. : J-856

PROJECT :  
 PROPOSED DEVELOPMENT ABOVE  
 LIGHT RAIL TIN WING STOP-TSWTL  
 NO.23,AREA 33,TIN SHUI WAI, N.T.

TITLE :  
 ALUM. WINDOW SECTION  
 TYPICAL LOCK & HINGES DETAIL

DATE : 02-Aug-21 SCALE : 1:40  
 DRAWN BY : Iwon CHECKED BY :

**美特鋁質有限公司**  
**MIDI ALUMINIUM FABRICATOR LTD.**  
 Units 6-8, Sunray Industrial Centre, 1/F  
 610 Cho Kwong Road, Kowloon  
 Tel:23489211-4 Fax:(852)2727866  
 DWG NO. : J856-SD-PW-D174g REV. : -

# 50窗

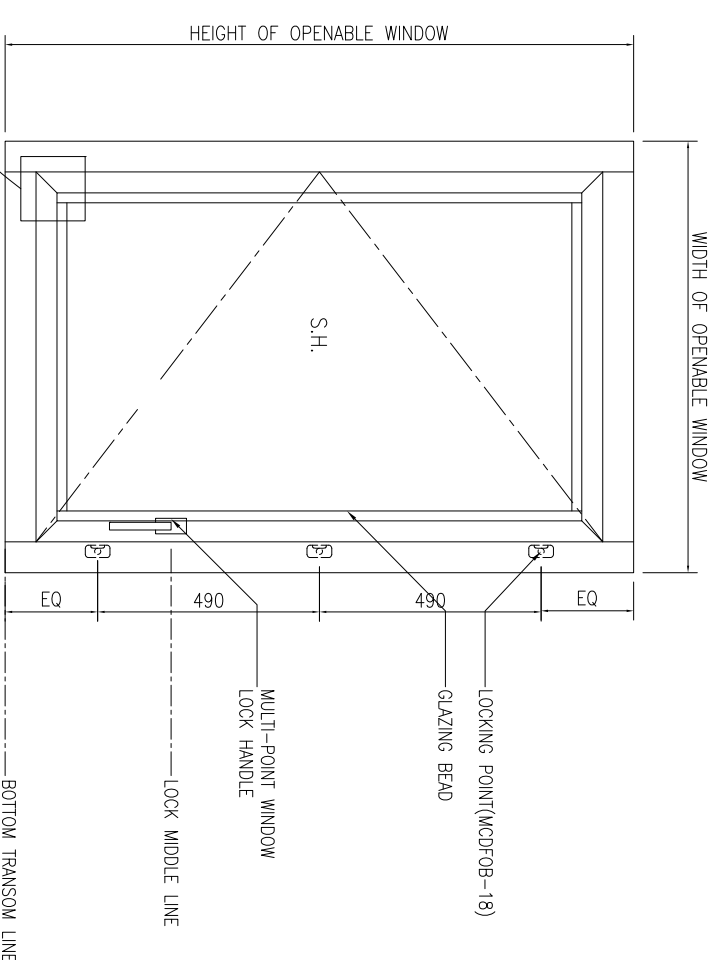
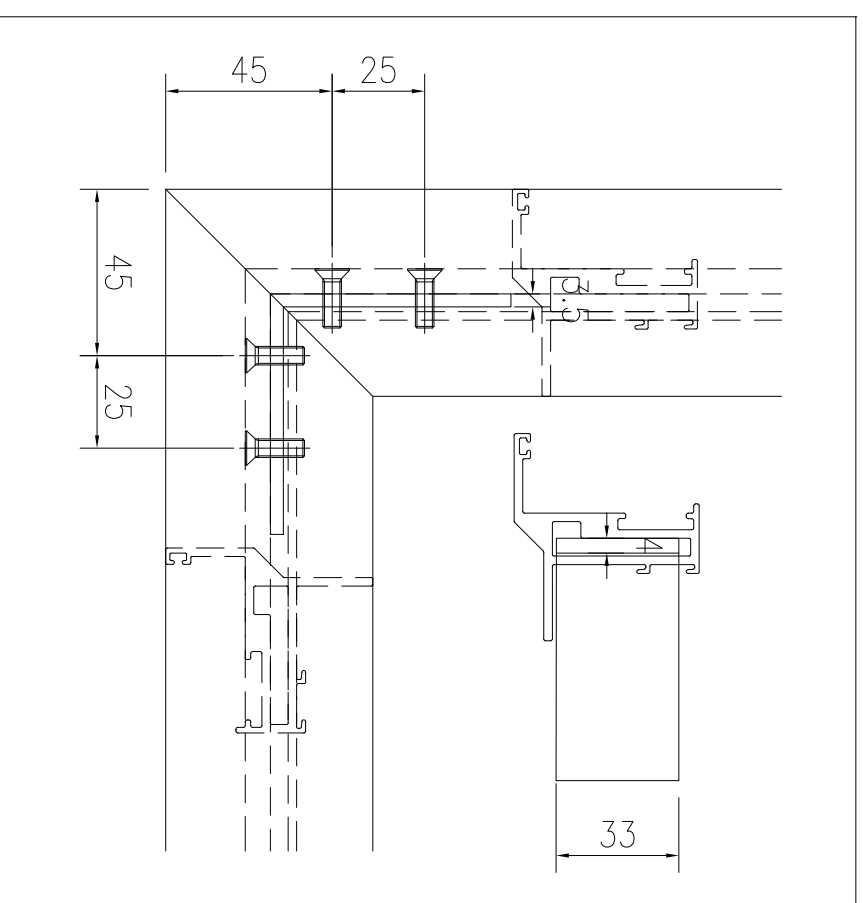

01 TYPICAL SECTION

S.F.L.

B.O. REF :

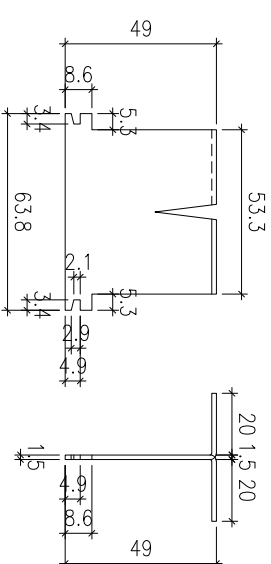
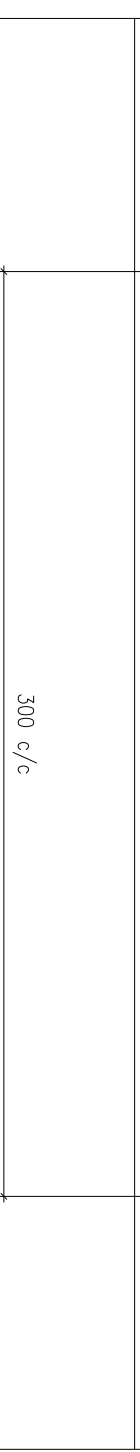

1 HORIZONTAL DETAIL  
SCALE 1:2

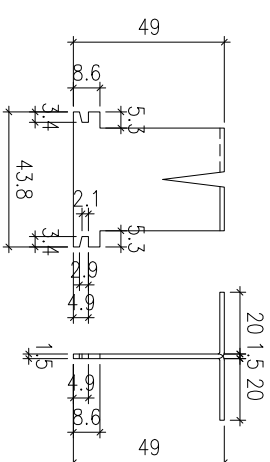

2 HORIZONTAL DETAIL  
SCALE 1:2

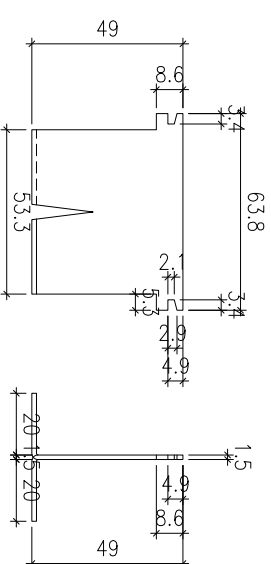

3 HORIZONTAL DETAIL  
SCALE 1:2

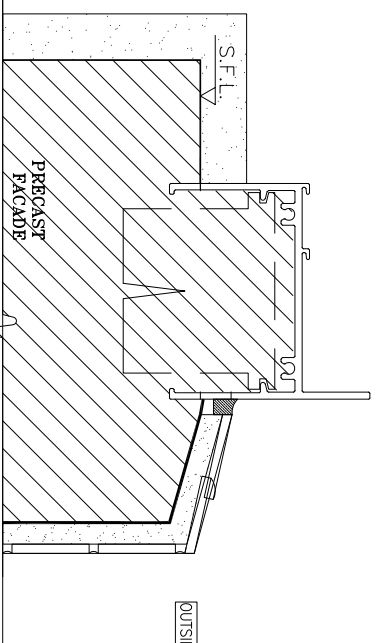
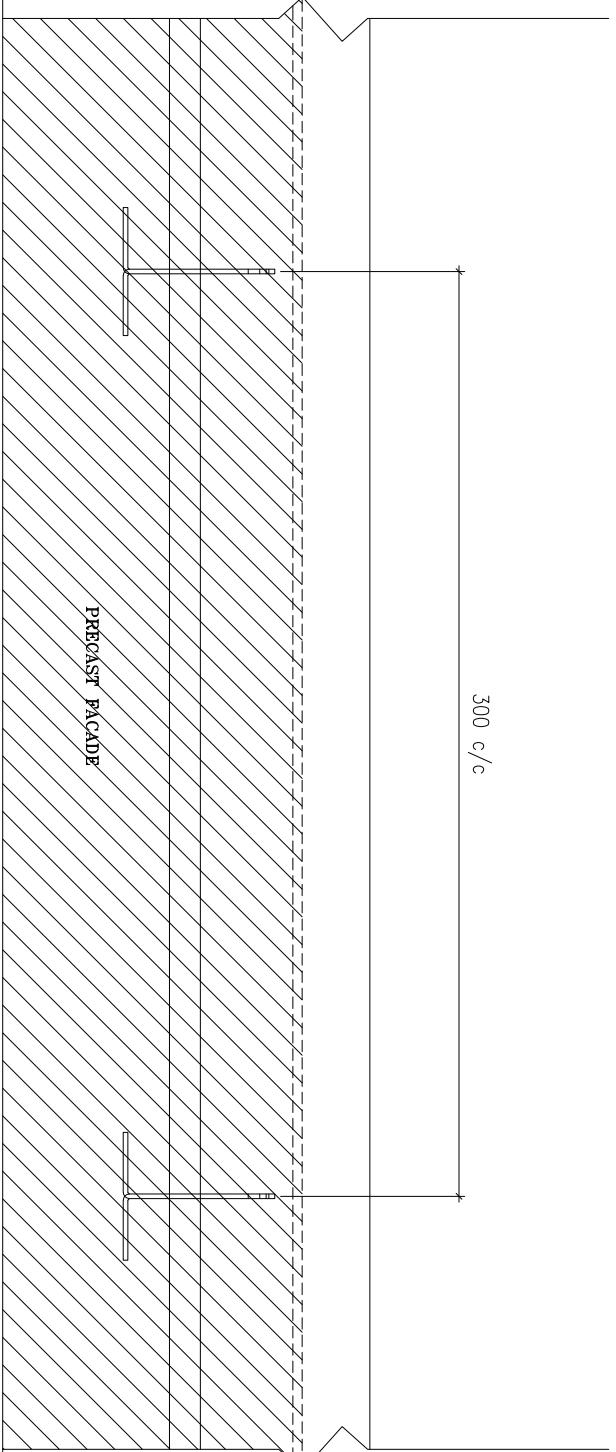

CLIENT :

**SUN HUNG KAI**  
REAL ESTATE AGENCY LTD.

42/F SUN HUNG KAI CENTRE, WANGCHAI, HONGKONG

ARCHITECT :

**lwk&partners**  
A R C H I T E C T S

MAIN CONTRACTOR :

**怡輝建築有限公司**  
**Yee Fai Building Contractors Ltd.**

STRUCTURAL ENGINEER :

**ARUP**

FAÇADE CONSULTANT:

**ALPHA CONSULTING LIMITED**  
Steel Structure & Façade Specialist

NOTE :

1. ALL DIMENSIONS ARE IN mm.
2. ALL ELEVATIONS ARE VIEWED FROM OUTSIDE.
3. ALL DIMENSIONS TO BE VERIFIED ON SITE BEFORE FABRICATION.

LEGEND :

⊗11—DETAIL MARK NO.  
X001—REFER SHEET NO.

1. F.F.L.--FINISHED FLOOR LEVEL
2. S.F.L.--STRUCTURAL FLOOR LEVEL
3. ⊗R--REVERSED DETAIL
4. GLASS LEGEND

EGL-1--8mmHS+12mm AIR GAP+10mmTP THK. I.G.U.  
EGL-2--10mm THK. CLEAR TEMPERED GLASS  
EGL-4--10mm THK. TEMPERED ACID ETCHED GLASS  
EGL-1A--8mmHS+12mm AIR GAP+8mmTP THK. I.G.U.

NO.	DATE	REVISION	BY

JOB NO. : J-8556

PROJECT :  
PROPOSED DEVELOPMENT ABOVE  
LIGHT RAIL TIN WING STOP TSWTL  
NO.23,AREA 33,TIN SHUI WAI, N.T.

TITLE :  
G.M.S FIXING LUG TYPICAL DETAIL  
FOR ALUM. WINDOW

DATE : 02-Aug-21 SCALE : 1:60

DRAWN BY : Ivon CHECKED BY :

**美特鋁質有限公司**  
**MIDI ALUMINIUM FABRICATOR LTD.**  
Units 6-8, Sunray Industrial Centre, 1/F  
610 Chee Kwong Road, Kowloon  
Tel:23489211-4 Fax:(852)2727866

DWG NO. : J856-SD-PW-D175 REV. : -

B.O. REF :

CLIENT :

**SUN HUNG KAI**  
REAL ESTATE AGENCY LTD.

42/F SUN HUNG KAI CENTRE, WANGCHAI, HONGKONG

ARCHITECT :

**IWK&partners**  
A R C H I T E C T S

MAIN CONTRACTOR :

**怡輝建築有限公司**  
Yee Fai Building Contractors Ltd.

STRUCTURAL ENGINEER :

**ARUP**

FAÇADE CONSULTANT:

**ALPHA CONSULTING LIMITED**  
Steel Structure & Façade Specialist

NOTE :

1. ALL DIMENSIONS ARE IN mm.
2. ALL ELEVATIONS ARE VIEWED FROM OUTSIDE.
3. ALL DIMENSIONS TO BE VERIFIED ON SITE BEFORE FABRICATION.

LEGEND :

⊗1—DETAIL MARK NO.  
X001—REFER SHEET NO.

1. F.F.L.--FINISHED FLOOR LEVEL
2. S.F.L.--STRUCTURAL FLOOR LEVEL
3. (R) --REVERSED DETAIL
4. GLASS LEGEND

EQ1-1--8mmHS+12mm AIR GAP+10mmTP THK. I.G.U.  
EQ1-2--10mm THK. CLEAR TEMPERED GLASS  
EQ1-4--10mm THK. TEMPERED ACID ETCHED GLASS  
EQ1-1A-8mmHS+12mm AIR GAP+8mmTP THK. I.G.U.

NO.	DATE	REVISION	BY

JOB NO. : J-856

PROJECT :  
PROPOSED DEVELOPMENT ABOVE  
LIGHT RAIL TIN WING STOP TSWTL  
NO.23,AREA 33,TIN SHUI WAI, N.T.

TITLE :

TYPICAL EARTHING  
BONDING DETAILS OF PRECAST

DATE : 02-Aug-21 SCALE : 1:40

DRAWN BY : Iwon CHECKED BY :

**美特鋁質有限公司**  
MIDI ALUMINIUM FABRICATOR LTD.  
Units 6-8, Sunray Industrial Centre, 1/F  
610 Chee Kwong Road, Kowloon  
Tel:23489211-4 Fax:(852)27277666

DWG NO. : J856-SD-PW-D176 REV. : -

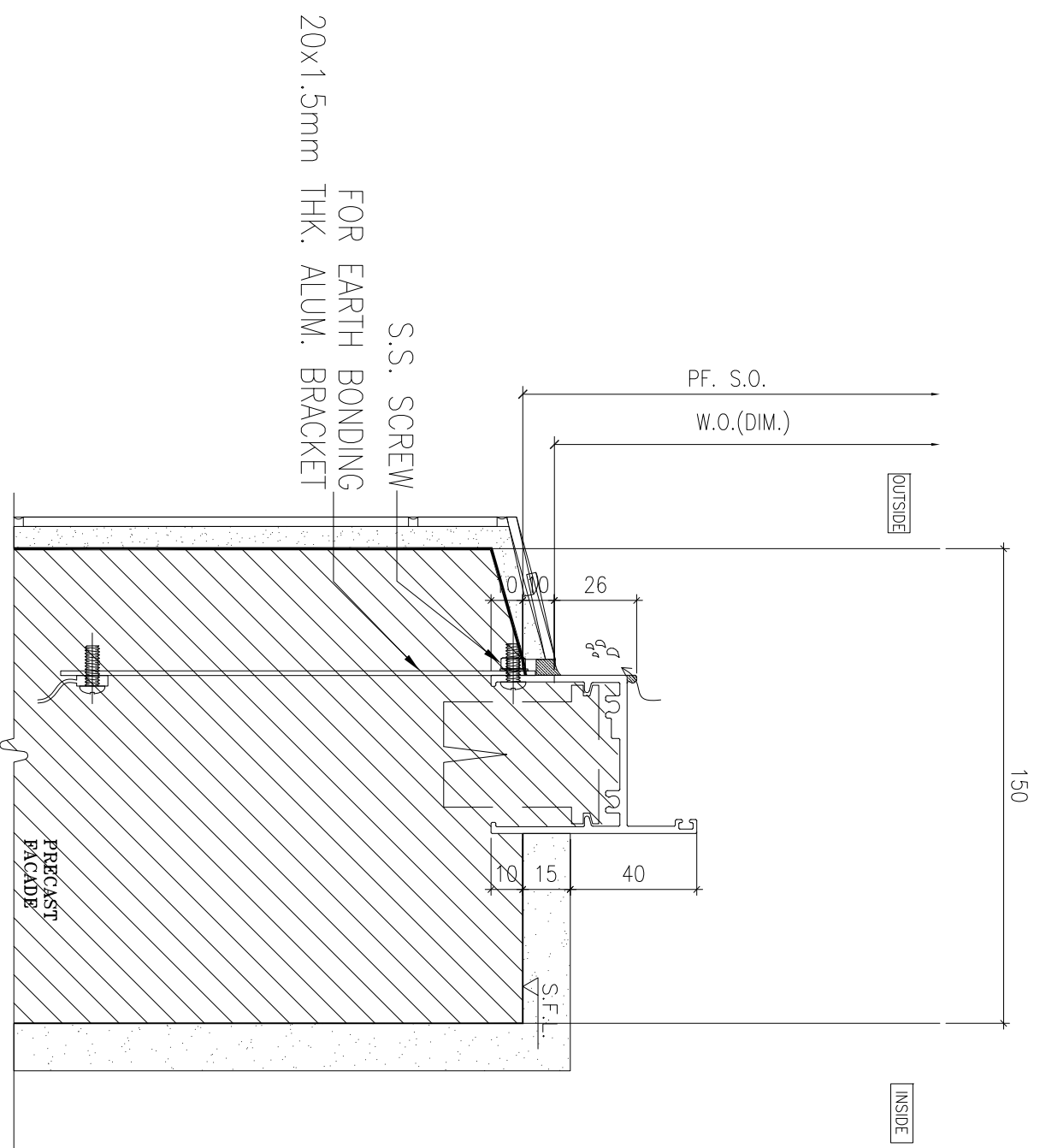

**1** HORIZONTAL DETAIL  
SCALE 1:2

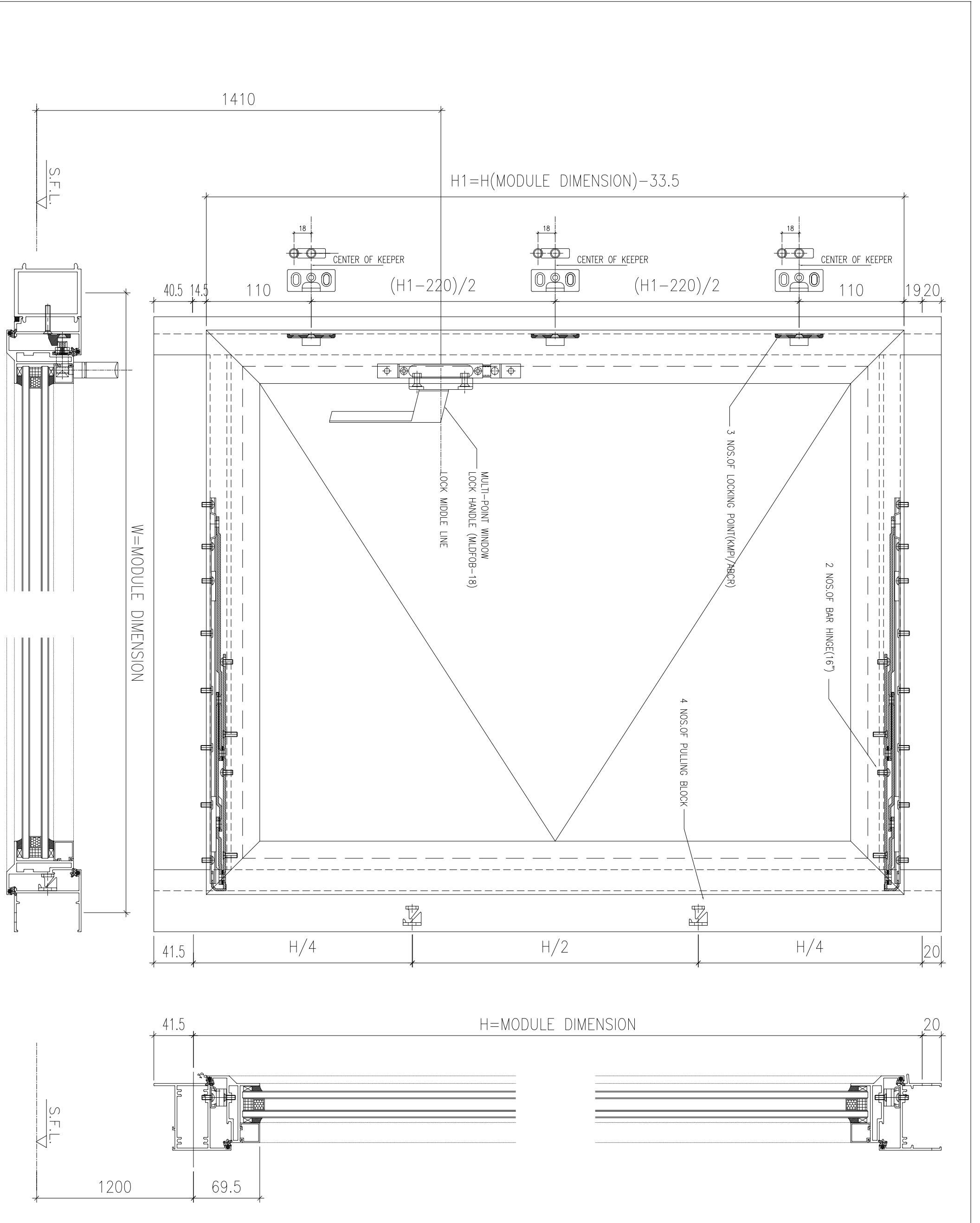

B.O. REF : . . . . .

CLIENT :



42/F SUN HUNG KAI CENTRE, WINGHUA, HONGKONG

ARCHITECT :



MAIN CONTRACTOR :



STRUCTURAL ENGINEER :



FAÇADE CONSULTANT :



Steel Structure & Façade Specialist

NOTE :

1. ALL DIMENSIONS ARE IN mm.
2. ALL ELEVATIONS ARE VIEWED FROM OUTSIDE.
3. ALL DIMENSIONS TO BE VERIFIED ON SITE BEFORE FABRICATION.

LEGEND :

- ⊗11 --- DETAIL MARK NO.
- ⊗001 --- REFER SHEET NO.

1. F.F.L. --- FINISHED FLOOR LEVEL
2. S.F.L. --- STRUCTURAL FLOOR LEVEL
3. ⊗ --- REVERSED DETAIL

4. GLASS LEGEND
- EGL-1 --- 8mmHS+12mm AIR GAP+10mmTP THK. LG.U.
- EGL-2 --- 10mm THK. CLEAR TEMPERED GLASS
- EGL-4 --- 10mm THK. TEMPERED ACID ETCHED GLASS
- EGL-1A --- 8mmHS+12mm AIR GAP+8mmTP THK. LG.U.

NO.	DATE	REVISION	BY

JOB NO. : J-856

PROJECT : PROPOSED DEVELOPMENT ABOVE LIGHT RAIL TIN WING STOP-TSWTL NO.23,AREA 33,TIN SHUI WAI, N.T.

TITLE : TYPICAL EARTHING BONDING DETAILS OF PRECAST

DATE : 02-Aug-21 SCALE : 1:60

DRAWN BY : Iwon CHECKED BY :

**美特铝业有限公司**  
 MIDT ALUMINUM FABRICATOR LTD.  
 Units 6-8, Sunray Industrial Centre, 1/F  
 610 Ona Kwong Road, Kowloon  
 Tel:23489211-4 Fax:(852)2727866  
 DWG NO. : J856-SD-PW-D177 REV. : -

W=MODULE DIMENSION

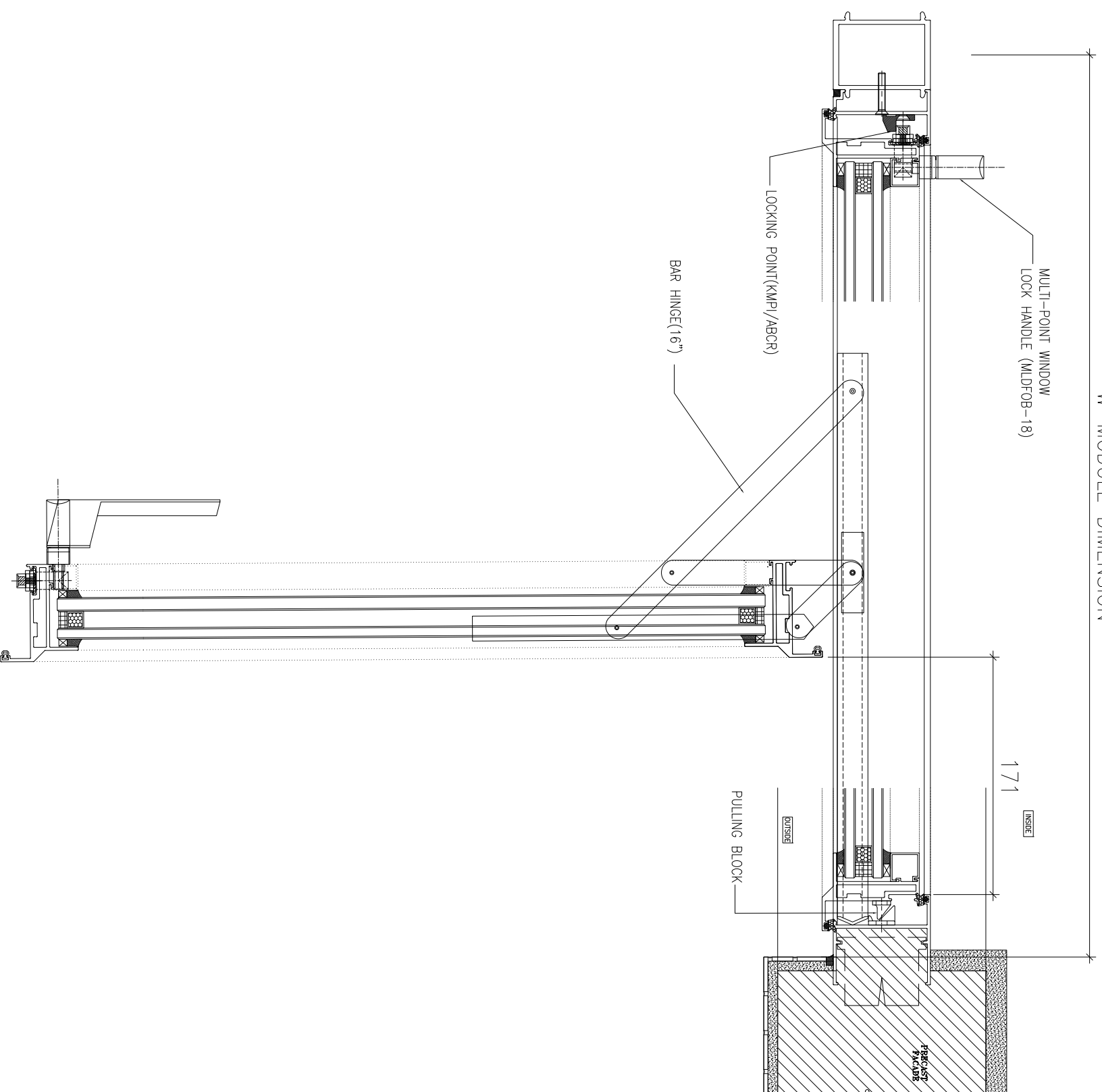

CLIENT :

**SUN HUNG KAI**  
REAL ESTATE AGENCY LTD.

42/F SUN HUNG KAI CENTRE, WANGCHAI, HONGKONG

ARCHITECT :

**lwk&partners**  
a r c h i t e c t s

MAIN CONTRACTOR :

**怡輝建築有限公司**  
**Yee Fai** Building Contractors Ltd.

STRUCTURAL ENGINEER :

**ARUP**

FACADE CONSULTANT:

**ALPHA CONSULTING LIMITED**  
Steel Structure & Facade Specialist

NOTE :

1. ALL DIMENSIONS ARE IN mm.
2. ALL ELEVATIONS ARE VIEWED FROM OUTSIDE.
3. ALL DIMENSIONS TO BE VERIFIED ON SITE BEFORE FABRICATION.

LEGEND :

⊗11—DETAIL MARK NO.  
X001—REFER SHEET NO.

1. F.F.L.--FINISHED FLOOR LEVEL
2. S.F.L.--STRUCTURAL FLOOR LEVEL
3. Ⓡ --REVERSED DETAIL
4. GLASS LEGEND

EGL-1--8mmHS+12mm AIR GAP+10mmTP THK. LG.U.  
EGL-2--10mm THK. CLEAR TEMPERED GLASS  
EGL-4--10mm THK. TEMPERED ACID ETCHED GLASS  
EGL-1A-8mmHS+12mm AIR GAP+8mmTP THK. LG.U.

NO.	DATE	REVISION	BY

JOB NO. : J-856

PROJECT :  
PROPOSED DEVELOPMENT ABOVE  
LIGHT RAIL TIN WING STOP TSWTL  
NO.23,AREA 33,TIN SHUI WAI, N.T.

TITLE :

TYPICAL EARTHING  
BONDING DETAILS OF PRECAST

DATE : 02-Aug-21 SCALE : 1:60

DRAWN BY : Iwon CHECKED BY :

**美特鋁質有限公司**  
**MIDI ALUMINIUM FABRICATOR LTD.**  
Units 6-8, Sunray Industrial Centre, 1/F  
610 Ona Kwo Ling Road, Kowloon  
Tel:23489211-4 Fax:(852)2727866

DWG NO. : J856-SD-PW-D178 REV. : -