

工程指示 / 要求簡箋(E.I.)

工程指示編號：EI / 3986 / 21

修改版次：F

工程編號：J - 856

工程名稱：天水圍天榮站

工程項目：佛沙窗 大圖(T3 修改大圖)

收件人：生統 / 謝永林 / 王良 發件人：Eric Liu

日期：04/01/2022

要求提供 / 確認 事項：

- | | | |
|------------------------------------|-------------------------------------|-------------------------------|
| <input type="checkbox"/> 初步鋁料 B.M. | <input type="checkbox"/> 加工拆圖，然後生產 | <input type="checkbox"/> 尺寸表 |
| <input type="checkbox"/> 正式鋁料 B.M. | <input type="checkbox"/> 技術上資料 / 指示 | <input type="checkbox"/> 報價 |
| <input type="checkbox"/> 配件 B.M. | <input type="checkbox"/> 樣辦或貨品說明書 | <input type="checkbox"/> 分判合約 |

內容：

F 版：附上修改 T3 大圖，請按此圖拆圖，試模窗優先

E 版：附上 8th 大圖(只有 T3)，請按此圖拆圖，T3 試模窗優先提供，另請提供保護方案

D 版：附上 7th 大圖，請按此圖拆圖，另請提供保護方案

C 版：附上 6TH 大圖，請按此圖拆圖，另請提供保護方案

B 版：附上確認修改基仔做 560 高資料

A 版：請查閱附件提供佛沙窗大圖 (5th submission)

優先計算鋁料 BM

王良：請安排提供本項目使用的保護方案

謝謝

請在 2022.01.05 前完成上列要求。

附：

以上項目為：

- 原合約工程包 原合約工程加 / 減賬 新工程報價

原因：-

分發東莞各部門：

- () 生產技術總監 連附件 () 技術部 連附件 () 生產部 連附件 () 機械設計部 連附件
 () 採購部 連附件 () 生產統籌部 連附件 () 小羅&清 連附件
 () 質檢部 連附件 () 會計部 連附件 () 報關組 連附件 () 其他 _____ 連附件

分發其他分判：

- (v) 水洪 連附件

分發香港各部門：

- () 行政部 連附件 () 會計部 連附件 () 統籌部 連附件 () 工程部地盤科文 連附件
 () 採購部 連附件 () QS 部 連附件 () 維修部 連附件 () 其他 _____ 連附件

傳遞編號：

HK 0016 / 22

發件人簽署：

項目經理簽署：

PROJECT :

7

PROPOSED DEVELOPMENT ABOVE
LIGHT RAIL TIN WING STOP, TSWTL
NO.23, AREA 33, TIN SHUI WAI, N.T.

SHOP DRAWING FOR ALUM. PRECAST WINDOW OF TOWER

DATE: 04-Jan-22

 美特鋁質有限公司
MIDI ALUMINIUM FABRICATOR LTD.

Units 6-8, Sunray Industrial Centre, 1/F
610 Cha Kwo Ling Road, Kowloon
Tel:23489211-4 Fax:(852)27727666

DRAWING SUBMISSION REGISTER

PROJECT: PROPOSED DEVELOPMENT ABOVE LIGHT RAIL TIN WING STOP, TSWTL NO.23, AREA 33, TIN SHUI WAI, N. T.		TITLE: ALUM. WINDOW OF TOWER SHOPDRAWING SUBMISSION		DATE OF ISSUE							SUBMISSION STATE (FOR B.D / A.S.D)		SUBMISSION STATE (FOR CLIENT / CONSULTANT)		SUBMISSION STATE (FOR ARCHITECT)		FABRICATION / CONSTRUCTION STATE					
DRAWING TITLE	DWG. NO.	REVISIONS							COMMENT DATE	REV.	STATE	COMMENT DATE	REV.	STATE	COMMENT DATE	REV.	STATE	DATE	REV.	DATE	REV.	DATE
		1	2	3	4	5	6	7														
COVER PAGE	J856-SD-PW-0000	-	A	B	C	D	E	F														
DRAWING REGISTER	J856-SD-PW-0001	-	A	A	A	B	C	D														
DRAWING REGISTER	J856-SD-PW-0002	-	A	A	A	B	C	D														
DRAWING REGISTER	J856-SD-PW-0003	-	A	B	B	C	D	E														
DRAWING REGISTER	J856-SD-PW-0004	-	A	B	B	B	B	C														
DRAWING REGISTER	J856-SD-PW-0005	-	A	B	B	C	C	D														
GENERAL NOTES FOR ALUM. WINDOW	J856-SD-PW-GN01	-	-	-	-	-	-	-														
EXTRUSION LIST FOR ALUM. WINDOW	J856-SD-PW-1101	-	A	A	A	B	B															
EXTRUSION LIST FOR ALUM. WINDOW	J856-SD-PW-1102	-	-	A	A	A	A															
PLAN FOR ALUM. WINDOW AT TOWER 1(3/F)	J856-SD-PW-3101	-	-	-	-	-	-	A	B													
PLAN FOR ALUM. WINDOW AT TOWER 1(6/F-22/F)	J856-SD-PW-3102	-	A	A	A	B	C	D														
PLAN FOR ALUM. WINDOW AT TOWER 1(43/F)	J856-SD-PW-3103	-	-	-	-	-	-	-														
PLAN FOR ALUM. WINDOW AT TOWER 1(45/F)	J856-SD-PW-3104	-	-	-	-	-	-	-														
PLAN FOR ALUM. WINDOW AT TOWER 1(46/F)	J856-SD-PW-3105	-	-	-	-	-	-	A	B													
PLAN FOR ALUM. WINDOW AT TOWER 2(3/F)	J856-SD-PW-3201	-	-	-	-	-	-	A	B													
PLAN FOR ALUM. WINDOW AT TOWER 2(6/F-42/F)	J856-SD-PW-3202	-	A	A	A	B	C	D														
PLAN FOR ALUM. WINDOW AT TOWER 2(43/F)	J856-SD-PW-3203	-	-	-	-	-	-	-														
PLAN FOR ALUM. WINDOW AT TOWER 2(45/F)	J856-SD-PW-3204	-	-	-	-	-	-	-														
PLAN FOR ALUM. WINDOW AT TOWER 2(46/F)	J856-SD-PW-3205	-	-	-	-	-	-	A	B													
PLAN FOR ALUM. WINDOW AT TOWER 3(3/F)	J856-SD-PW-3301	-	-	-	-	-	-	A	B													
PLAN FOR ALUM. WINDOW AT TOWER 3(6/F-42/F)	J856-SD-PW-3302	-	A	B	C	D	E	F														
PLAN FOR ALUM. WINDOW AT TOWER 3(43/F)	J856-SD-PW-3303	-	-	-	-	-	-	-														
PLAN FOR ALUM. WINDOW AT TOWER 3(45/F)	J856-SD-PW-3304	-	-	-	-	-	-	-														
PLAN FOR ALUM. WINDOW AT TOWER 3(46/F)	J856-SD-PW-3305	-	-	-	-	-	-	-														
WINDOW SCHEDULE FOR TOWER 1 ALUM. WINDOW	J856-SD-PW-5101	-	A	A	A	B	C	D														
WINDOW SCHEDULE FOR TOWER 1 ALUM. WINDOW	J856-SD-PW-5102	-	-	-	-	A	B	C														
WINDOW SCHEDULE FOR TOWER 1 ALUM. WINDOW	J856-SD-PW-5103	-	-	-	-	A	B	C														
WINDOW SCHEDULE FOR TOWER 1 ALUM. WINDOW	J856-SD-PW-5104	-	A	A	A	B	C	D														
WINDOW SCHEDULE FOR TOWER 1 ALUM. WINDOW	J856-SD-PW-5105	-	-	-	-	A	B	C														
WINDOW SCHEDULE FOR TOWER 1 ALUM. WINDOW	J856-SD-PW-5106	-	A	A	A	B	C	D														
WINDOW SCHEDULE FOR TOWER 1 ALUM. WINDOW	J856-SD-PW-5107	-	-	-	-	A	B	C														
WINDOW SCHEDULE FOR TOWER 1 ALUM. WINDOW	J856-SD-PW-5108	-	-	-	-	A	B	C														
WINDOW SCHEDULE FOR TOWER 1 ALUM. WINDOW	J856-SD-PW-5109	-	A	A	A	B	C	D														
WINDOW SCHEDULE FOR TOWER 1 ALUM. WINDOW	J856-SD-PW-5110	-	A	A	A	B	C	D														
WINDOW SCHEDULE FOR TOWER 1 ALUM. WINDOW	J856-SD-PW-5111	-	A	A	A	B	C	D														
WINDOW SCHEDULE FOR TOWER 1 ALUM. WINDOW	J856-SD-PW-5112	-	A	A	A	B	B															
WINDOW SCHEDULE FOR TOWER 1 ALUM. WINDOW	J856-SD-PW-5113	-	A																			
WINDOW SCHEDULE FOR TOWER 1 ALUM. WINDOW	J856-SD-PW-5114	-	A																			
WINDOW SCHEDULE FOR TOWER 1 ALUM. WINDOW	J856-SD-PW-5115	-	-	-	-																	
WINDOW SCHEDULE FOR TOWER 1 ALUM. WINDOW	J856-SD-PW-5116	-	-	-	-																	
WINDOW SCHEDULE FOR TOWER 1 ALUM. WINDOW	J856-SD-PW-5117	-	A																			
WINDOW SCHEDULE FOR TOWER 1 ALUM. WINDOW	J856-SD-PW-5118	-	A																			

IN-HOUSE DESIGN CHECKER

DRAWING SUBMISSION REGISTER

PROJECT:
PROPOSED DEVELOPMENT ABOVE
LIGHT RAIL TIN WING STOP, TSWTL
NO.23, AREA 33, TIN SHUI WAI, N.T.
TITLE:
ALUM. WINDOW OF TOWER
SHOPDRAWING SUBMISSION

DRAWING TITLE	DWG. NO.	DATE OF ISSUE							SUBMISSION STATE (FOR B.D / A.S.D)			SUBMISSION STATE (FOR CLIENT / CONSULTANT)			SUBMISSION STATE (FOR ARCHITECT)			FABRICATION / CONSTRUCTION STATE				
		ISSUE	1	2	3	4	5	6	7	AP - APPROVED	AC - APPROVED SUB. TO CONDITION	NA - NOT APPROVED	AP - APPROVED	AC - APPROVED SUB. TO CONDITION	NA - NOT APPROVED	AP - APPROVED	AC - APPROVED SUB. TO CONDITION	NA - NOT APPROVED	ISSUE TO CHINA OFFICE	ISSUE TO SITE	ISSUE TO SUB-CONTRACTOR	
		DAY	22	12	18	30	2	29	21													
WINDOW SCHEDULE FOR TOWER 1 ALUM. WINDOW	J856-SD-PW-5119	-	A																			
WINDOW SCHEDULE FOR TOWER 1 ALUM. WINDOW	J856-SD-PW-5120	-	A																			
WINDOW SCHEDULE FOR TOWER 1 ALUM. WINDOW	J856-SD-PW-5121	-	A																			
WINDOW SCHEDULE FOR TOWER 1 ALUM. WINDOW	J856-SD-PW-5122	-	A																			
WINDOW SCHEDULE FOR TOWER 1 ALUM. WINDOW	J856-SD-PW-5123	-																				
WINDOW SCHEDULE FOR TOWER 1 ALUM. WINDOW	J856-SD-PW-5124	-																				
WINDOW SCHEDULE FOR TOWER 1 ALUM. WINDOW	J856-SD-PW-5125	-	A																			
WINDOW SCHEDULE FOR TOWER 1 ALUM. WINDOW	J856-SD-PW-5126	-	A																			
WINDOW SCHEDULE FOR TOWER 1 ALUM. WINDOW	J856-SD-PW-5127	-																				
WINDOW SCHEDULE FOR TOWER 1 ALUM. WINDOW	J856-SD-PW-5128	-																				
WINDOW SCHEDULE FOR TOWER 1 ALUM. WINDOW	J856-SD-PW-5129	-																				
WINDOW SCHEDULE FOR TOWER 1 ALUM. WINDOW	J856-SD-PW-5130	-																				
WINDOW SCHEDULE FOR TOWER 1 ALUM. WINDOW	J856-SD-PW-5131	-																				
WINDOW SCHEDULE FOR TOWER 1 ALUM. WINDOW	J856-SD-PW-5132	-																				
WINDOW SCHEDULE FOR TOWER 1 ALUM. WINDOW	J856-SD-PW-5133	-																				
WINDOW SCHEDULE FOR TOWER 1 ALUM. WINDOW	J856-SD-PW-5134	-																				
WINDOW SCHEDULE FOR TOWER 1 ALUM. WINDOW	J856-SD-PW-5135	-																				
WINDOW SCHEDULE FOR TOWER 1 ALUM. WINDOW	J856-SD-PW-5136	-																				
WINDOW SCHEDULE FOR TOWER 1 ALUM. WINDOW	J856-SD-PW-5137	-																				
WINDOW SCHEDULE FOR TOWER 1 ALUM. WINDOW	J856-SD-PW-5138	-																				
WINDOW SCHEDULE FOR TOWER 1 ALUM. WINDOW	J856-SD-PW-5139	-																				
WINDOW SCHEDULE FOR TOWER 1 ALUM. WINDOW	J856-SD-PW-5140	-																				
WINDOW SCHEDULE FOR TOWER 1 ALUM. WINDOW	J856-SD-PW-5141	-																				
WINDOW SCHEDULE FOR TOWER 1 ALUM. WINDOW	J856-SD-PW-5142	-																				
WINDOW SCHEDULE FOR TOWER 1 ALUM. WINDOW	J856-SD-PW-5143	-																				
WINDOW SCHEDULE FOR TOWER 1 ALUM. WINDOW	J856-SD-PW-5144	-																				
WINDOW SCHEDULE FOR TOWER 1 ALUM. WINDOW	J856-SD-PW-5145	-																				
WINDOW SCHEDULE FOR TOWER 2 ALUM. WINDOW	J856-SD-PW-5201	-	A	A	A	B	C	D														
WINDOW SCHEDULE FOR TOWER 2 ALUM. WINDOW	J856-SD-PW-5202	-				A	B	C														
WINDOW SCHEDULE FOR TOWER 2 ALUM. WINDOW	J856-SD-PW-5203	-				A	B	C														
WINDOW SCHEDULE FOR TOWER 2 ALUM. WINDOW	J856-SD-PW-5204	-	A	A	A	B	C	D														
WINDOW SCHEDULE FOR TOWER 2 ALUM. WINDOW	J856-SD-PW-5205	-				A	B	C														
WINDOW SCHEDULE FOR TOWER 2 ALUM. WINDOW	J856-SD-PW-5206	-	A	A	A	B	C	D														
WINDOW SCHEDULE FOR TOWER 2 ALUM. WINDOW	J856-SD-PW-5207	-				A	B	C														
WINDOW SCHEDULE FOR TOWER 2 ALUM. WINDOW	J856-SD-PW-5208	-				A	B	C														
WINDOW SCHEDULE FOR TOWER 2 ALUM. WINDOW	J856-SD-PW-5209	-	A	A	A	B	C	D														
WINDOW SCHEDULE FOR TOWER 2 ALUM. WINDOW	J856-SD-PW-5210	-	A	A	A	B	C	D														
WINDOW SCHEDULE FOR TOWER 2 ALUM. WINDOW	J856-SD-PW-5211	-	A	A	A	B	C	D														
WINDOW SCHEDULE FOR TOWER 2 ALUM. WINDOW	J856-SD-PW-5211a	/																				
WINDOW SCHEDULE FOR TOWER 2 ALUM. WINDOW	J856-SD-PW-5212	-																				
WINDOW SCHEDULE FOR TOWER 2 ALUM. WINDOW	J856-SD-PW-5213	-																				
WINDOW SCHEDULE FOR TOWER 2 ALUM. WINDOW	J856-SD-PW-5214	-	A																			
WINDOW SCHEDULE FOR TOWER 2 ALUM. WINDOW	J856-SD-PW-5215	-	A																			

IN-HOUSE DESIGN CHECKER



業特鋁質有限公司
MIDI ALUMINIUM FABRICATOR LTD.
 Units 6-8, Sunray Industrial Centre, 1/F,
 610 Chee Kwo Ling Road, Kowloon
 Tel: 23489211-4 Fax: (852) 27727666
 DWG NO. : J856-SD-PW-0002 REV. : D

DRAWING SUBMISSION REGISTER

PROJECT: PROPOSED DEVELOPMENT ABOVE LIGHT RAIL TIN WING STOP, TSWTL NO.23, AREA 33, TIN SHUI WAI, N.T.		DATE OF ISSUE							SUBMISSION STATE (FOR B.D / A.S.D)		SUBMISSION STATE (FOR CLIENT / CONSULTANT)		SUBMISSION STATE (FOR ARCHITECT)		FABRICATION / CONSTRUCTION STATE								
TITLE: ALUM. WINDOW OF TOWER SHOPDRAWING SUBMISSION		ISSUE	1	2	3	4	5	6	7	AP - APPROVED	AP - APPROVED	AP - APPROVED	ISSUE TO CHINA OFFICE	ISSUE TO SITE	ISSUE TO SUB-CONTRACTOR								
		DAY	22	12	18	30	5	29	21	AC - APPROVED SUB. TO CONDITION	AC - APPROVED SUB. TO CONDITION	AC - APPROVED SUB. TO CONDITION											
		MONTH	9	10	10	10	11	11	12	NA - NOT APPROVED	NA - NOT APPROVED	NA - NOT APPROVED											
		YEAR	21	21	21	21	21	21	21														
DRAWING TITLE		DWG. NO.	REVISIONS							COMMENT DATE	REV.	STATE	COMMENT DATE	REV.	STATE	COMMENT DATE	REV.	STATE	REV.	DATE	REV.	DATE	
WINDOW SCHEDULE FOR TOWER 2 ALUM. WINDOW	J856-SD-PW-5216	-	A																				
WINDOW SCHEDULE FOR TOWER 2 ALUM. WINDOW	J856-SD-PW-5217	-	A																				
WINDOW SCHEDULE FOR TOWER 2 ALUM. WINDOW	J856-SD-PW-5218	-	A																				
WINDOW SCHEDULE FOR TOWER 2 ALUM. WINDOW	J856-SD-PW-5219	-	A																				
WINDOW SCHEDULE FOR TOWER 2 ALUM. WINDOW	J856-SD-PW-5220	-	-																				
WINDOW SCHEDULE FOR TOWER 2 ALUM. WINDOW	J856-SD-PW-5221	-	-																				
WINDOW SCHEDULE FOR TOWER 2 ALUM. WINDOW	J856-SD-PW-5222	-	A																				
WINDOW SCHEDULE FOR TOWER 2 ALUM. WINDOW	J856-SD-PW-5223	-	A																				
WINDOW SCHEDULE FOR TOWER 2 ALUM. WINDOW	J856-SD-PW-5224	-	-																				
WINDOW SCHEDULE FOR TOWER 2 ALUM. WINDOW	J856-SD-PW-5225	-	-																				
WINDOW SCHEDULE FOR TOWER 2 ALUM. WINDOW	J856-SD-PW-5226	-	-																				
WINDOW SCHEDULE FOR TOWER 2 ALUM. WINDOW	J856-SD-PW-5227	-	-																				
WINDOW SCHEDULE FOR TOWER 2 ALUM. WINDOW	J856-SD-PW-5228	-	-																				
WINDOW SCHEDULE FOR TOWER 2 ALUM. WINDOW	J856-SD-PW-5229	-	-																				
WINDOW SCHEDULE FOR TOWER 2 ALUM. WINDOW	J856-SD-PW-5230	-	-																				
WINDOW SCHEDULE FOR TOWER 2 ALUM. WINDOW	J856-SD-PW-5231	-	-																				
WINDOW SCHEDULE FOR TOWER 2 ALUM. WINDOW	J856-SD-PW-5232	-	-																				
WINDOW SCHEDULE FOR TOWER 2 ALUM. WINDOW	J856-SD-PW-5233	-	-																				
WINDOW SCHEDULE FOR TOWER 2 ALUM. WINDOW	J856-SD-PW-5234	-	-																				
WINDOW SCHEDULE FOR TOWER 2 ALUM. WINDOW	J856-SD-PW-5235	-	-																				
WINDOW SCHEDULE FOR TOWER 2 ALUM. WINDOW	J856-SD-PW-5236	-	-																				
WINDOW SCHEDULE FOR TOWER 2 ALUM. WINDOW	J856-SD-PW-5237	-	-																				
WINDOW SCHEDULE FOR TOWER 2 ALUM. WINDOW	J856-SD-PW-5238	-	-																				
WINDOW SCHEDULE FOR TOWER 2 ALUM. WINDOW	J856-SD-PW-5239	-	-																				
WINDOW SCHEDULE FOR TOWER 2 ALUM. WINDOW	J856-SD-PW-5240	-	-																				
WINDOW SCHEDULE FOR TOWER 2 ALUM. WINDOW	J856-SD-PW-5241	-	-																				
WINDOW SCHEDULE FOR TOWER 3 ALUM. WINDOW	J856-SD-PW-5301	-	-	A	B	C	D	E															
WINDOW SCHEDULE FOR TOWER 3 ALUM. WINDOW	J856-SD-PW-5302	-	-	-																			
WINDOW SCHEDULE FOR TOWER 3 ALUM. WINDOW	J856-SD-PW-5303	-	A	B	C	D	E	F															
WINDOW SCHEDULE FOR TOWER 3 ALUM. WINDOW	J856-SD-PW-5304	-	A	B	C	D	E	F															
WINDOW SCHEDULE FOR TOWER 3 ALUM. WINDOW	J856-SD-PW-5305	-	A	B	C	D	E	F															
WINDOW SCHEDULE FOR TOWER 3 ALUM. WINDOW	J856-SD-PW-5306	-	-	A	B	C	D	E															
WINDOW SCHEDULE FOR TOWER 3 ALUM. WINDOW	J856-SD-PW-5307	-	-	A	B	C	D	E															
WINDOW SCHEDULE FOR TOWER 3 ALUM. WINDOW	J856-SD-PW-5308	-	A	B	C	D	E	F															
WINDOW SCHEDULE FOR TOWER 3 ALUM. WINDOW	J856-SD-PW-5309	-	A	B	C	D	E	F															
WINDOW SCHEDULE FOR TOWER 3 ALUM. WINDOW	J856-SD-PW-5310	-	A	B	B	B	C	D															
WINDOW SCHEDULE FOR TOWER 3 ALUM. WINDOW	J856-SD-PW-5311	-	-	A	B	B	B	C															
WINDOW SCHEDULE FOR TOWER 3 ALUM. WINDOW	J856-SD-PW-5312	-	-	A	A	A	A	B															
WINDOW SCHEDULE FOR TOWER 3 ALUM. WINDOW	J856-SD-PW-5312a	-	A	B																			
WINDOW SCHEDULE FOR TOWER 3 ALUM. WINDOW	J856-SD-PW-5313	-	A	B	B	B	B	C															
WINDOW SCHEDULE FOR TOWER 3 ALUM. WINDOW	J856-SD-PW-5314	-	A	B																			
WINDOW SCHEDULE FOR TOWER 3 ALUM. WINDOW	J856-SD-PW-5315	-	-	A																			

IN-HOUSE DESIGN CHECKER

DRAWING SUBMISSION REGISTER

PROJECT: PROPOSED DEVELOPMENT ABOVE LIGHT RAIL TIN WING STOP, TSWTL NO.23, AREA 33, TIN SHUI WAI, N. T. TITLE: ALUM. WINDOW OF TOWER SHOPDRAWING SUBMISSION		DATE OF ISSUE							SUBMISSION STATE (FOR B.D / A.S.D)		SUBMISSION STATE (FOR CLIENT / CONSULTANT)		SUBMISSION STATE (FOR ARCHITECT)		FABRICATION / CONSTRUCTION STATE						
		ISSUE DAY	1	2	3	4	5	6	7	AP - APPROVED AC - APPROVED SUB. TO CONDITION NA - NOT APPROVED	AP - APPROVED AC - APPROVED SUB. TO CONDITION NA - NOT APPROVED	AP - APPROVED AC - APPROVED SUB. TO CONDITION NA - NOT APPROVED	ISSUE TO CHINA OFFICE	ISSUE TO SITE	ISSUE TO SUB-CONTRACTOR						
DRAWING TITLE	DWG. NO.	REVISIONS							COMMENT DATE	REV.	STATE	COMMENT DATE	REV.	STATE	COMMENT DATE	REV.	STATE	REV.	DATE	REV.	DATE
WINDOW SCHEDULE FOR TOWER 3 ALUM. WINDOW	J856-SD-PW-5316	-	-	A																	
WINDOW SCHEDULE FOR TOWER 3 ALUM. WINDOW	J856-SD-PW-5317	-	-	A	B																
WINDOW SCHEDULE FOR TOWER 3 ALUM. WINDOW	J856-SD-PW-5318	-	-	A																	
WINDOW SCHEDULE FOR TOWER 3 ALUM. WINDOW	J856-SD-PW-5319	-	-	A																	
WINDOW SCHEDULE FOR TOWER 3 ALUM. WINDOW	J856-SD-PW-5320	-	-	A	B																
WINDOW SCHEDULE FOR TOWER 3 ALUM. WINDOW	J856-SD-PW-5321	-	-	A	B																
WINDOW SCHEDULE FOR TOWER 3 ALUM. WINDOW	J856-SD-PW-5322	-	-	A																	
WINDOW SCHEDULE FOR TOWER 3 ALUM. WINDOW	J856-SD-PW-5323	-	-	A																	
WINDOW SCHEDULE FOR TOWER 3 ALUM. WINDOW	J856-SD-PW-5324	-	-	A	B																
WINDOW SCHEDULE FOR TOWER 3 ALUM. WINDOW	J856-SD-PW-5325	-	-	A																	
WINDOW SCHEDULE FOR TOWER 3 ALUM. WINDOW	J856-SD-PW-5326	-	-	A																	
WINDOW SCHEDULE FOR TOWER 3 ALUM. WINDOW	J856-SD-PW-5327	-	-	A	B																
WINDOW SCHEDULE FOR TOWER 3 ALUM. WINDOW	J856-SD-PW-5328	-	-	A	B																
WINDOW SCHEDULE FOR TOWER 3 ALUM. WINDOW	J856-SD-PW-5329	-	-	A																	
WINDOW SCHEDULE FOR TOWER 3 ALUM. WINDOW	J856-SD-PW-5330	-	-	A	B																
WINDOW SCHEDULE FOR TOWER 3 ALUM. WINDOW	J856-SD-PW-5331	-	-	A	B																
WINDOW SCHEDULE FOR TOWER 3 ALUM. WINDOW	J856-SD-PW-5332	-	-	A	B																
WINDOW SCHEDULE FOR TOWER 3 ALUM. WINDOW	J856-SD-PW-5333	-	-	A	B																
WINDOW SCHEDULE FOR TOWER 3 ALUM. WINDOW	J856-SD-PW-5334	-	-	A	B																
WINDOW SCHEDULE FOR TOWER 3 ALUM. WINDOW	J856-SD-PW-5335	-	-	A	B																
WINDOW SCHEDULE FOR TOWER 3 ALUM. WINDOW	J856-SD-PW-5336	-	-	A																	
WINDOW SCHEDULE FOR TOWER 3 ALUM. WINDOW	J856-SD-PW-5337	-	-	A																	
WINDOW SCHEDULE FOR TOWER 3 ALUM. WINDOW	J856-SD-PW-5338	-	-	A																	
WINDOW SCHEDULE FOR TOWER 3 ALUM. WINDOW	J856-SD-PW-5339	-	-	A																	
WINDOW SCHEDULE FOR TOWER 3 ALUM. WINDOW	J856-SD-PW-5340	-	-	A																	
WINDOW SCHEDULE FOR TOWER 3 ALUM. WINDOW	J856-SD-PW-5341	-	-																		
WINDOW SCHEDULE FOR TOWER 3 ALUM. WINDOW	J856-SD-PW-5342	-	-																		
WINDOW SCHEDULE FOR TOWER 3 ALUM. WINDOW	J856-SD-PW-5343	-	-																		
WINDOW SCHEDULE FOR TOWER 3 ALUM. WINDOW	J856-SD-PW-5344	-	-																		
WINDOW SCHEDULE FOR TOWER 3 ALUM. WINDOW	J856-SD-PW-5345	-	-																		
WINDOW SCHEDULE FOR TOWER 3 ALUM. WINDOW	J856-SD-PW-5346	-	-																		
WINDOW SCHEDULE FOR TOWER 3 ALUM. WINDOW	J856-SD-PW-5347	-	-																		
WINDOW SCHEDULE FOR TOWER 3 ALUM. WINDOW	J856-SD-PW-5348	-	-																		
WINDOW SCHEDULE FOR TOWER 3 ALUM. WINDOW	J856-SD-PW-5349	-	-																		
WINDOW SCHEDULE FOR TOWER 3 ALUM. WINDOW	J856-SD-PW-5350	-	-																		
WINDOW SCHEDULE FOR TOWER 3 ALUM. WINDOW	J856-SD-PW-5351	-	-																		
WINDOW SCHEDULE FOR TOWER 3 ALUM. WINDOW	J856-SD-PW-5352	-	-																		
WINDOW SCHEDULE FOR TOWER 3 ALUM. WINDOW	J856-SD-PW-5353	-	-																		
WINDOW SCHEDULE FOR TOWER 3 ALUM. WINDOW	J856-SD-PW-5354	-	-																		
WINDOW SCHEDULE FOR TOWER 3 ALUM. WINDOW	J856-SD-PW-5355	-	-																		
WINDOW SCHEDULE FOR TOWER 3 ALUM. WINDOW	J856-SD-PW-5356	-	-																		
WINDOW SCHEDULE FOR TOWER 3 ALUM. WINDOW	J856-SD-PW-5357	-	-																		

IN-HOUSE DESIGN CHECKER

B.O. REF :

CLIENT :

SUN HUNG KAI
REAL ESTATE AGENCY LTD.
42/F, SUN HUNG KAI CENTRE, WANCHAI, HONGKONG

ARCHITECT :

IWK&partners
a r c h i t e c t s

MAIN CONTRACTOR :

怡輝建築有限公司
Yee Fai Building Contractors Ltd.

STRUCTURAL ENGINEER :

ARUP

FAÇADE CONSULTANT :

ALPHA CONSULTING LIMITED
Steel Structure & Façade Specialist

NOTE :

1. ALL DIMENSIONS ARE IN mm.
2. ALL ELEVATIONS ARE VIEWED FROM OUTSIDE.
3. ALL DIMENSIONS TO BE VERIFIED ON SITE BEFORE FABRICATION.

LEGEND :

X1 — DETAIL MARK NO.
X001 — REFER SHEET NO.

1. F.F.L. -- FINISHED FLOOR LEVEL
2. S.F.L. -- STRUCTURAL FLOOR LEVEL
3. (R) -- REVERSED DETAIL

4. GLASS LEGEND

EGL-1 -- 9mmHS+12mm AIR GAP+8mmTP THK. I.G.U.
EGL-2 -- 10mm THK. CLEAR TEMPERED GLASS
EGL-4 -- 10mm THK. TEMPERED ACID ETCHED GLASS

NO.	DATE	REVISION SUBJECT TO ARCH COMMENT	BY
B	21/12/2021	REVISION SUBJECT TO ARCH COMMENT	lvon
A	29/11/2021	REVISION SUBJECT TO ARCH COMMENT	lvon

JOB NO. : J-856

PROJECT :

PROPOSED DEVELOPMENT ABOVE
LIGHT RAIL TIN WING STOP TSWTL
NO.23, AREA 33, TIN SHUI WAI, N.T.

TITLE : PLAN FOR ALUM. WINDOW
AT TOWER 3

DATE : 02-Aug-21 SCALE : 1:40

DRAWN BY : lvon CHECKED BY :

美特鋁質有限公司
MIDI ALUMINIUM FABRICATOR LTD.
Units 6-8, Sunny Industrial Centre, 1/F
610 Che Kwo Ling Road, Kowloon
Tel:23489211-4 Fax:85227272666

DWG NO. : JB56-SD-PW-3301

REV. : B

11000 3580 2475 1150 2325 3800 2200

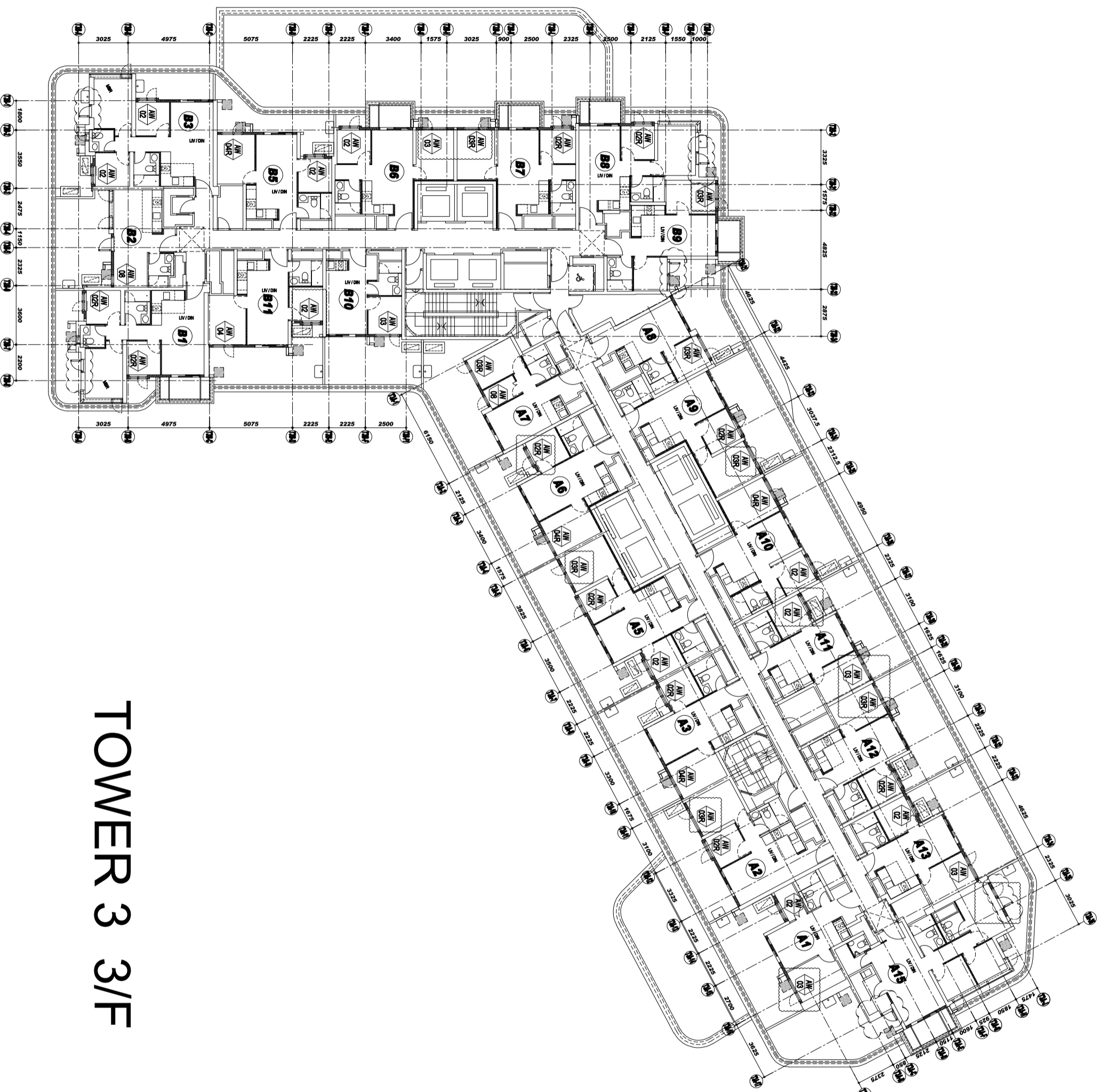

TOWER 3 3/F

B.O. REF :

CLIENT :

SUN HUNG KAI
REAL ESTATE AGENCY LTD.
42/F SUN HUNG KAI CENTRE, WANCHAI, HONGKONG

ARCHITECT :

IWK&partners
a r c h i t e c t s

MAIN CONTRACTOR :

怡輝建築有限公司
Yee Fai Building Contractors Ltd.

STRUCTURAL ENGINEER :

ARUP

FAÇADE CONSULTANT :

ALPHA CONSULTING LIMITED
Steel Structure & Façade Specialist

NOTE :

1. ALL DIMENSIONS ARE IN mm.
2. ALL ELEVATIONS ARE VIEWED FROM OUTSIDE.
3. ALL DIMENSIONS TO BE VERIFIED ON SITE BEFORE FABRICATION.

LEGEND :

- X1 --- DETAIL MARK NO.
- X001 --- REFER SHEET NO.

1. F.F.L. -- FINISHED FLOOR LEVEL
2. S.F.L. -- STRUCTURAL FLOOR LEVEL
3. (R) -- REVERSED DETAIL

4. GLASS LEGEND

- EG1-1 -- 6mmHS+12mm AIR GAP+8mmTP THK. I.G.U.
- EG1-2 -- 10mm THK. CLEAR TEMPERED GLASS
- EG1-4 -- 10mm THK. TEMPERED ACID ETCHED GLASS

NO.	DATE	REVISION SUBJECT TO ARCH COMMENT	BY
E	29/11/2021	REVISION SUBJECT TO ARCH COMMENT	Wen
D	02/11/2021	REVISION SUBJECT TO ARCH COMMENT	Wen
C	28/10/2021	REVISION SUBJECT TO ARCH COMMENT	Wen
B	18/10/2021	REVISION SUBJECT TO ARCH COMMENT	Wen
A	30/09/2021	REVISION SUBJECT TO ARCH COMMENT	Wen

JOB NO. : J-856

PROJECT :

PROPOSED DEVELOPMENT ABOVE
LIGHT RAIL TIN WING STOP TSWTL
NO.23, AREA 33, TIN SHUI WAI, N.T.

TITLE : PLAN FOR IN-SITU WINDOW
AT TOWER 3

DATE : 02-Aug-21 SCALE : 1:40

DRAWN BY : IvoM CHECKED BY :

美特鋁質有限公司
MIDI ALUMINIUM FABRICATOR LTD.
Units 6-8, Sunny Industrial Centre, 1/F
610 Che Kwo Ling Road, Kowloon
Tel:23489211-4 Fax:8522727666

DWG NO. : JB56-SD-IW-3302

REV. : E

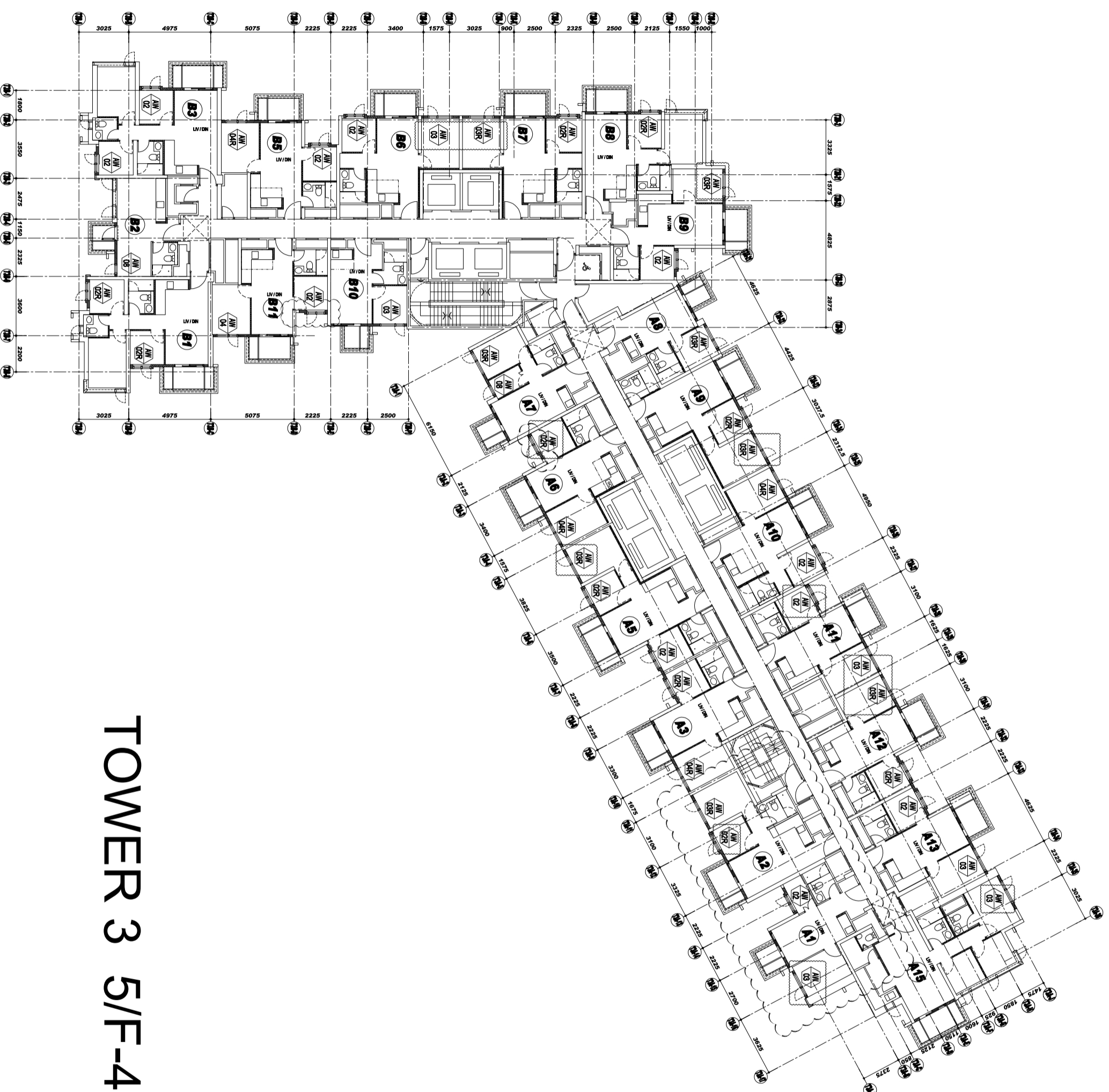

TOWER 3 5/F-42/F

B.O. REF :

CLIENT :

SUN HUNG KAI
REAL ESTATE AGENCY LTD.
42/F SUN HUNG KAI CENTRE, WANGCHAI, HONGKONG

ARCHITECT :
IWK&partners
a r c h i t e c t s

MAIN CONTRACTOR :
怡輝建築有限公司
Yee Fai Building Contractors Ltd.

STRUCTURAL ENGINEER :
ARUP

FAÇADE CONSULTANT:
ALPHA CONSULTING LIMITED
Steel Structure & Façade Specialist

NOTE :
1. ALL DIMENSIONS ARE IN mm.
2. ALL ELEVATIONS ARE VIEWED FROM OUTSIDE.
3. ALL DIMENSIONS TO BE VERIFIED ON SITE BEFORE FABRICATION.

LEGEND :
X1 --- DETAIL MARK NO.
X001 --- REFER SHEET NO.

1. F.F.L.--FINISHED FLOOR LEVEL
2. S.F.L.--STRUCTURAL FLOOR LEVEL
3. (R) --REVERSED DETAIL
4. GLASS LEGEND
EGL-1--8mmHS+12mm AIR GAP+10mmTP THK. I.G.U.
EGL-2--10mm THK. CLEAR TEMPERED GLASS
EGL-4--10mm THK. TEMPERED ACID ETCHED GLASS
EGL-1A-8mmHS+12mm AIR GAP+8mmTP THK. I.G.U.

NO.	DATE	REVISION SUBJECT TO ARCH/COMMENT	BY
E	14/12/2021	REVISION SUBJECT TO ARCH/COMMENT	hvn
D	29/11/2021	REVISION SUBJECT TO ARCH/COMMENT	hvn
C	02/11/2021	REVISION SUBJECT TO ARCH/COMMENT	hvn
B	29/10/2021	REVISION SUBJECT TO ARCH/COMMENT	hvn
A	18/10/2021	REVISION SUBJECT TO ARCH/COMMENT	hvn

JOB NO. : J-856
PROJECT : PROPOSED DEVELOPMENT ABOVE LIGHT RAIL TIN WING STOP TSWTL NO.23,AREA 33,TIN SHUI WAI, N.T.
TITLE : WINDOW SCHEDULE FOR TOWER 3 ALUM. WINDOW

DATE : 02-Aug-21 SCALE : 1:40
DRAWN BY : ivon CHECKED BY :

美特鋁質有限公司
MIDI ALUMINIUM FABRICATOR LTD.
Units 6-8, Sunny Industrial Centre, 1/F
610 Che Kwo Ling Road, Kowloon
Tel:23489211-4 Fax:85227272666
DWG NO. : 856-SD-PW-5301 REV. : E

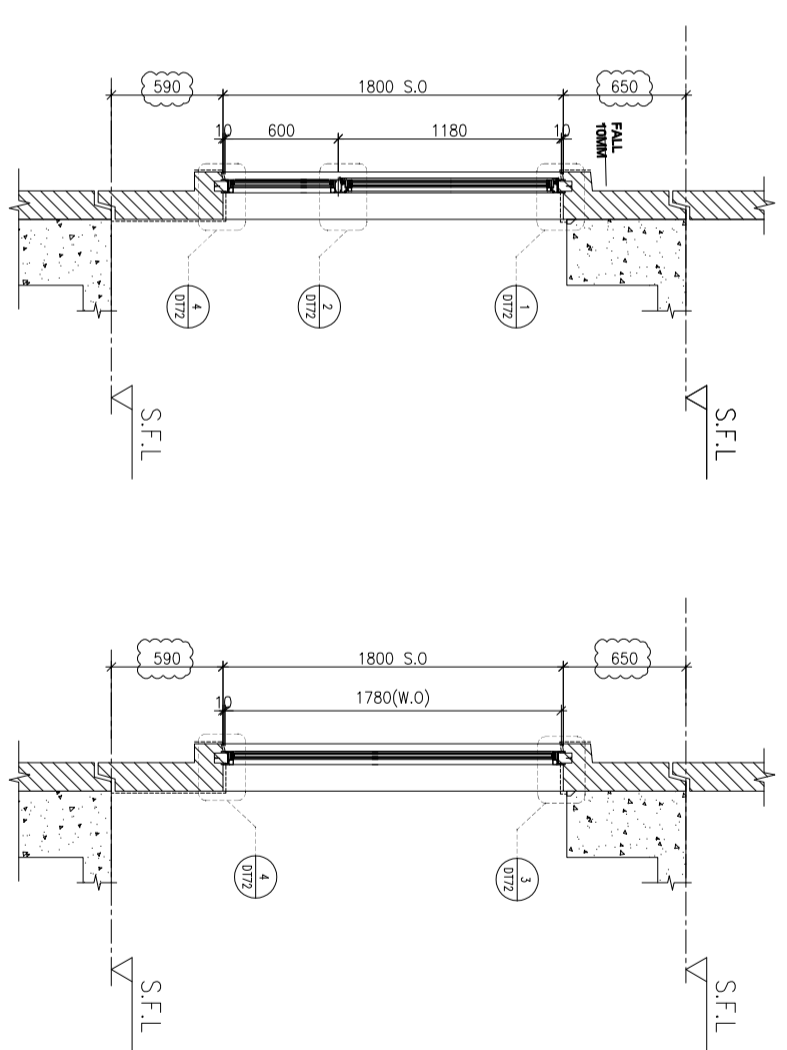
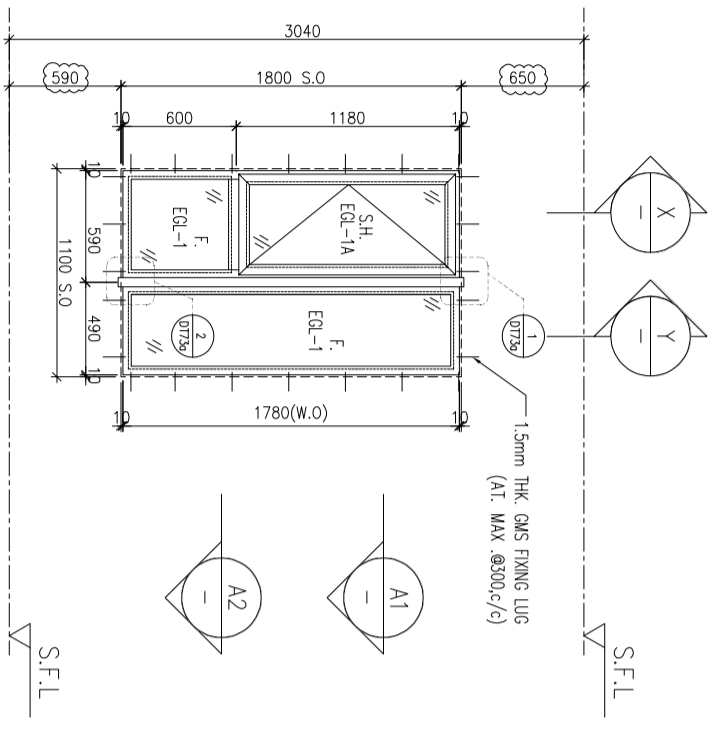

ELEVATION

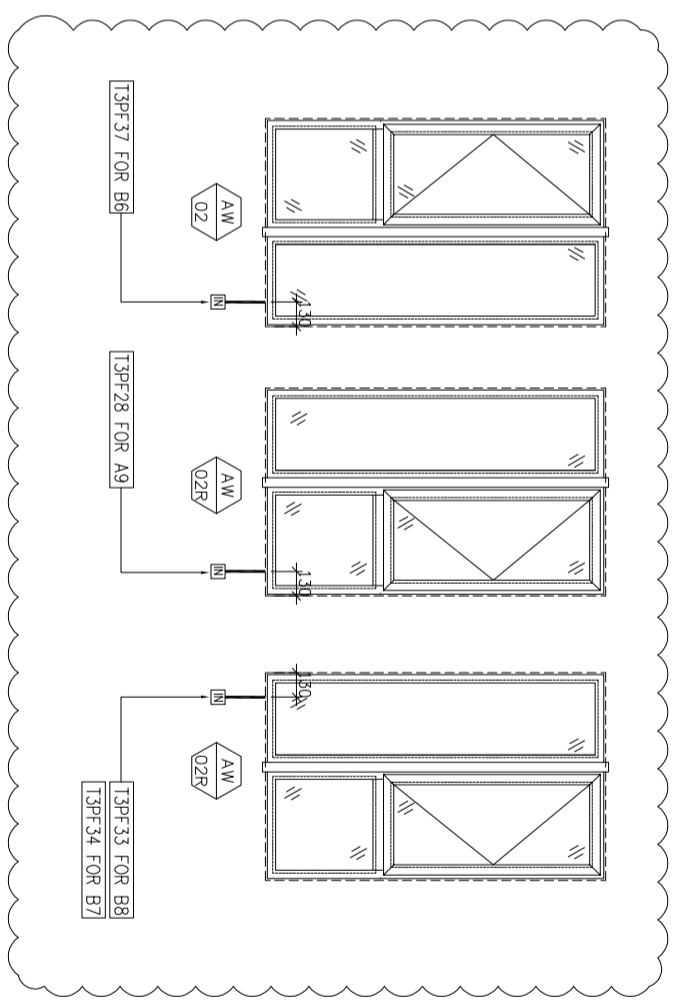
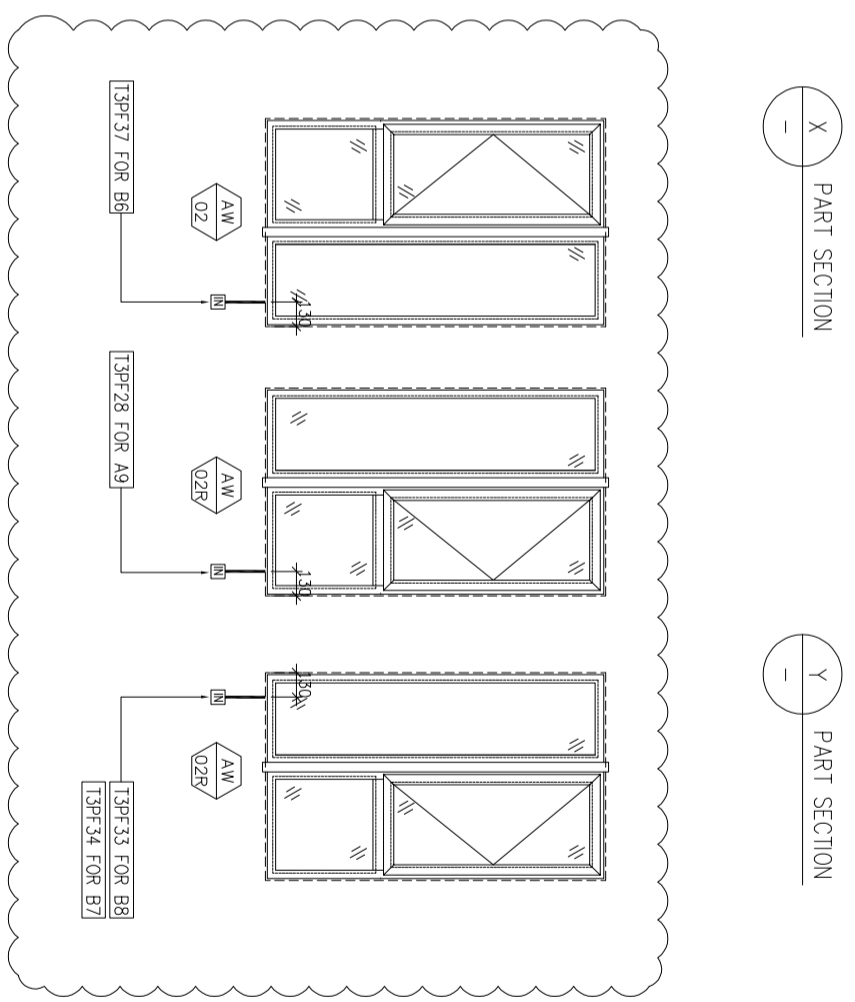
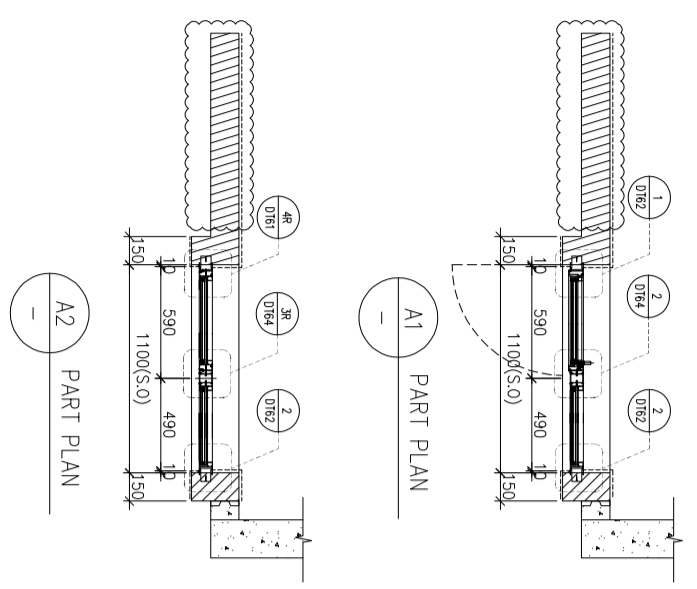

WINDOW MARK	AW 02	AW 02R
LOCATION	3/F~42/F(4/F,13/F,14/F,24/F,34/F OMITTED) UNIT B6	3/F~42/F(4/F,13/F,14/F,24/F,34/F OMITTED) UNIT A9,B7,B8
SECTION	70mm ALUM. SECTION	70mm ALUM. SECTION
GLAZING	EGL-1,EGL-1A	EGL-1,EGL-1A
QUANTITY	35 Nos.	35 Nos / 35 Nos / 35 Nos
REMARKS	FAÇADE(TYPE T3PF02 FOR 3/F~42/F)	FAÇADE(TYPE T3PF02R FOR 3/F~42/F)

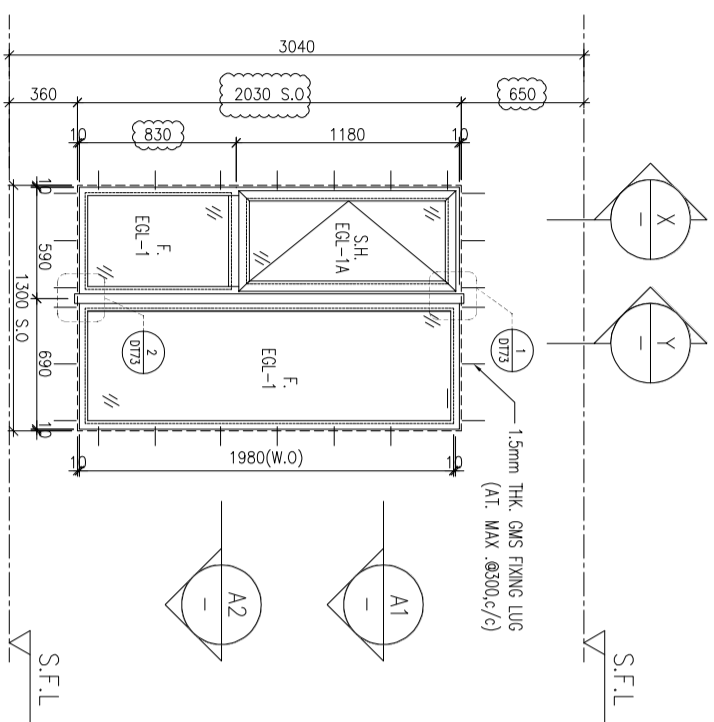

ELEVATION

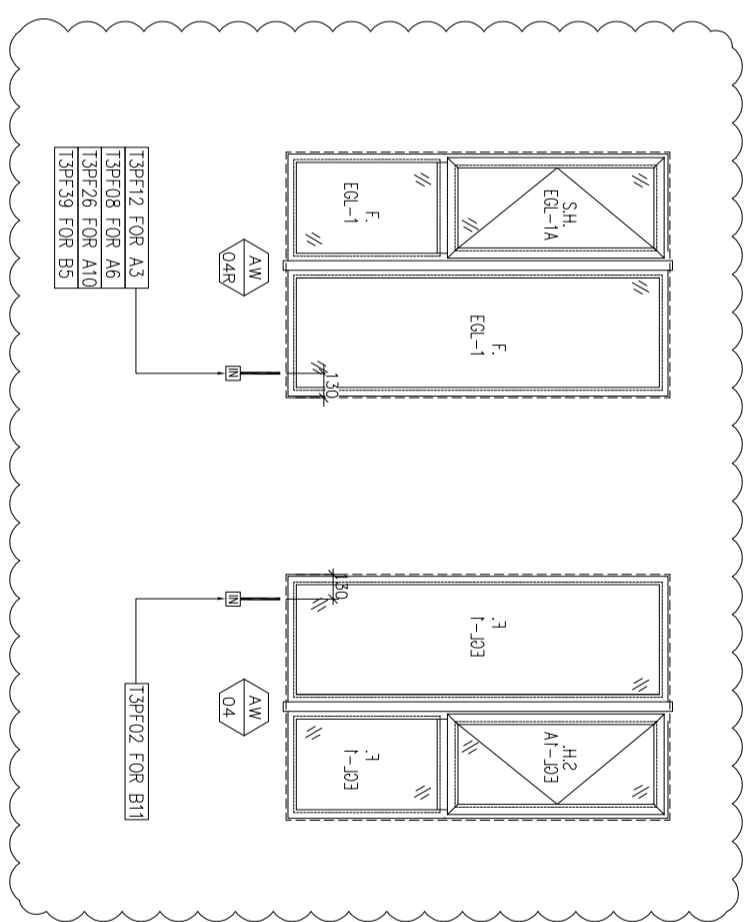
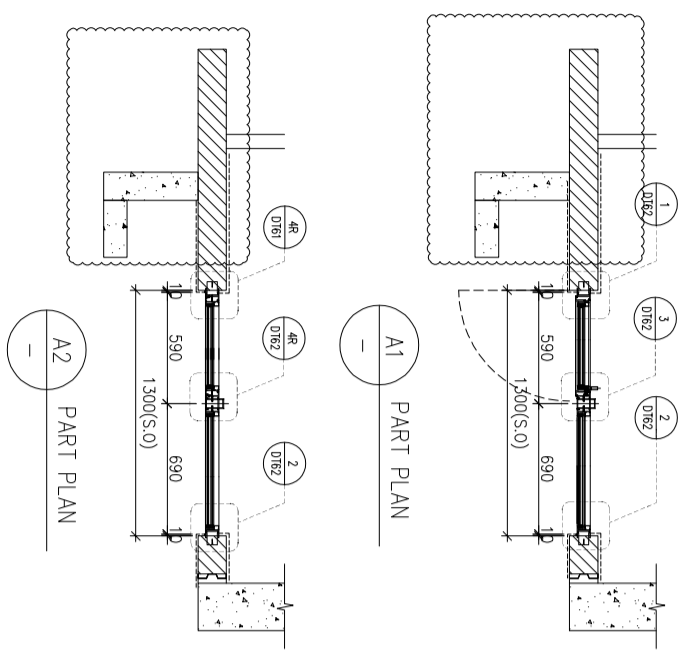
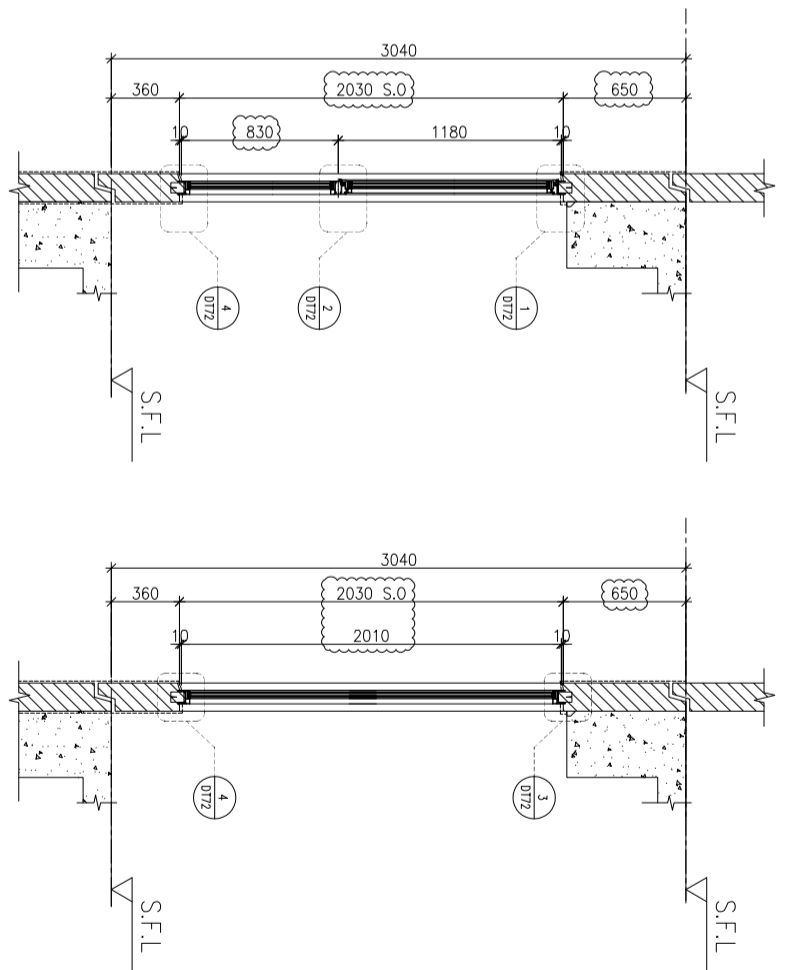

WINDOW MARK	AW 04/R	AW 04
LOCATION	3/F~42/F(4/F,13/F,14/F,24/F,34/F OMITTED) UNIT A3,A6,A10,B5	3/F~42/F(4/F,13/F,14/F,24/F,34/F OMITTED) UNIT B11
SECTION	70mm ALUM. SECTION	70mm ALUM. SECTION
GLAZING	EGL-1,EGL-1A	EGL-1,EGL-1A
QUANTITY	35 Nos / 35 Nos / 35 Nos / 35 Nos	35 Nos
REMARKS	FACADETYPE T3PF04 FOR 3/F~42/F)	FACADETYPE T3PF04R FOR 3/F~42/F)

B.O. REF :

CLIENT :
SUN HUNG KAI
 REAL ESTATE AGENCY LTD.
 42/F SUN HUNG KAI CENTRE, WANGCHAI, HONGKONG

ARCHITECT :
IWK&partners
 a r c h i t e c t s

MAIN CONTRACTOR :
怡輝建築有限公司
Yee Fai Building Contractors Ltd.

STRUCTURAL ENGINEER :
ARUP

FACADE CONSULTANT:
ALPHA CONSULTING LIMITED
 Steel Structure & Facade Specialist

NOTE :
 1. ALL DIMENSIONS ARE IN mm.
 2. ALL ELEVATIONS ARE VIEWED FROM OUTSIDE.
 3. ALL DIMENSIONS TO BE VERIFIED ON SITE BEFORE FABRICATION.
 LEGEND :
 X1 -- DETAIL MARK NO.
 X001 -- REFER SHEET NO.

1. F.F.L.--FINISHED FLOOR LEVEL
 2. S.F.L.--STRUCTURAL FLOOR LEVEL
 3. (R) --REVERSED DETAIL
 4. GLASS LEGEND
 EGL-1--8mmHS+12mm AIR GAP+10mmTP THK. I.G.U.
 EGL-2--10mm THK. CLEAR TEMPERED GLASS
 EGL-4--10mm THK. TEMPERED ACID ETCHED GLASS
 EGL-1A-8mmHS+12mm AIR GAP+8mmTP THK. I.G.U.

NO.	DATE	REVISION	REVISION SUBJECT TO ARCH COMMENT	BY
F	14/12/2021		REVISION SUBJECT TO ARCH COMMENT	Wen
E	29/11/2021		REVISION SUBJECT TO ARCH COMMENT	Wen
D	02/11/2021		REVISION SUBJECT TO ARCH COMMENT	Wen
C	28/10/2021		REVISION SUBJECT TO ARCH COMMENT	Wen
B	18/10/2021		REVISION SUBJECT TO ARCH COMMENT	Wen
A	27/09/2021		REVISION SUBJECT TO ARCH COMMENT	Wen

JOB NO. : J-856
 PROJECT : PROPOSED DEVELOPMENT ABOVE LIGHT RAIL TIN WING STOP TSWTL NO.23,AREA 33,TIN SHUI WAI, N.T.
 TITLE : WINDOW SCHEDULE FOR TOWER 3 ALUM. WINDOW

DATE : 02-Aug-21 SCALE : 1:40
 DRAWN BY : Ivon CHECKED BY :

美特鋁質有限公司
 MIDI ALUMINIUM FABRICATOR LTD.
 Units 6-8, Sunny Industrial Centre, 1/F
 610 Che Kwo Ling Road, Kowloon
 Tel:23489211-4 Fax:85227272666
 DWG NO. : 856-SD-PW-5302 REV. : F

B.O. REF :

CLIENT :

SUN HUNG KAI
REAL ESTATE AGENCY LTD.
42/F SUN HUNG KAI CENTRE, WANGCHAI, HONGKONG

ARCHITECT :

IWK&partners
ARCHITECTS

MAIN CONTRACTOR :

怡輝建築有限公司
Yee Fai Building Contractors Ltd.

STRUCTURAL ENGINEER :

ARUP

FAÇADE CONSULTANT :

ALPHA CONSULTING LIMITED
Steel Structure & Façade Specialist

NOTE :

1. ALL DIMENSIONS ARE IN mm.
2. ALL ELEVATIONS ARE VIEWED FROM OUTSIDE.
3. ALL DIMENSIONS TO BE VERIFIED ON SITE BEFORE FABRICATION.

LEGEND :

- (X1) --- DETAIL MARK NO.
- (X001) --- REFER SHEET NO.

1. F.F.L. --- FINISHED FLOOR LEVEL
2. S.F.L. --- STRUCTURAL FLOOR LEVEL
3. (R) --- REVERSED DETAIL

4. GLASS LEGEND

EQI-1 --- 8mmHS+12mm AIR GAP+10mmTP THK. I.G.U.
 EQI-2 --- 10mm THK. CLEAR TEMPERED GLASS
 EQI-4 --- 10mm THK. CLEAR TEMPERED ACID ETCHED GLASS
 EQI-1A --- 8mmHS+12mm AIR GAP+8mmTP THK. I.G.U.

NO.	DATE	REVISION SUBJECT TO ARCH COMMENT	BY
A	27/09/2021	REVISION SUBJECT TO ARCH COMMENT	NON
B	18/10/2021	REVISION SUBJECT TO ARCH COMMENT	NON
C	28/10/2021	REVISION SUBJECT TO ARCH COMMENT	NON
D	02/11/2021	REVISION SUBJECT TO ARCH COMMENT	NON
E	29/11/2021	REVISION SUBJECT TO ARCH COMMENT	NON
F	14/12/2021	REVISION SUBJECT TO ARCH COMMENT	NON

JOB NO. : J-856

PROJECT :

PROPOSED DEVELOPMENT ABOVE LIGHT RAIL TIN WING STOP TSWTL NO.23, AREA 33, TIN SHUI WAI, N.T.

TITLE :

WINDOW SCHEDULE FOR TOWER 3 ALUM. WINDOW

DATE : 02-Aug-21 SCALE : 1:40

DRAWN BY : IYVN CHECKED BY :

美特鋁質有限公司
MIDI ALUMINIUM FABRICATOR LTD.
Units 6-8, Sunny Industrial Centre, 1/F
610 Che Kwo Ling Road, Kowloon
Tel: 23489211-4 Fax: (852) 27272666
DWG NO. : 856-SD-PW-5303 REV. : F

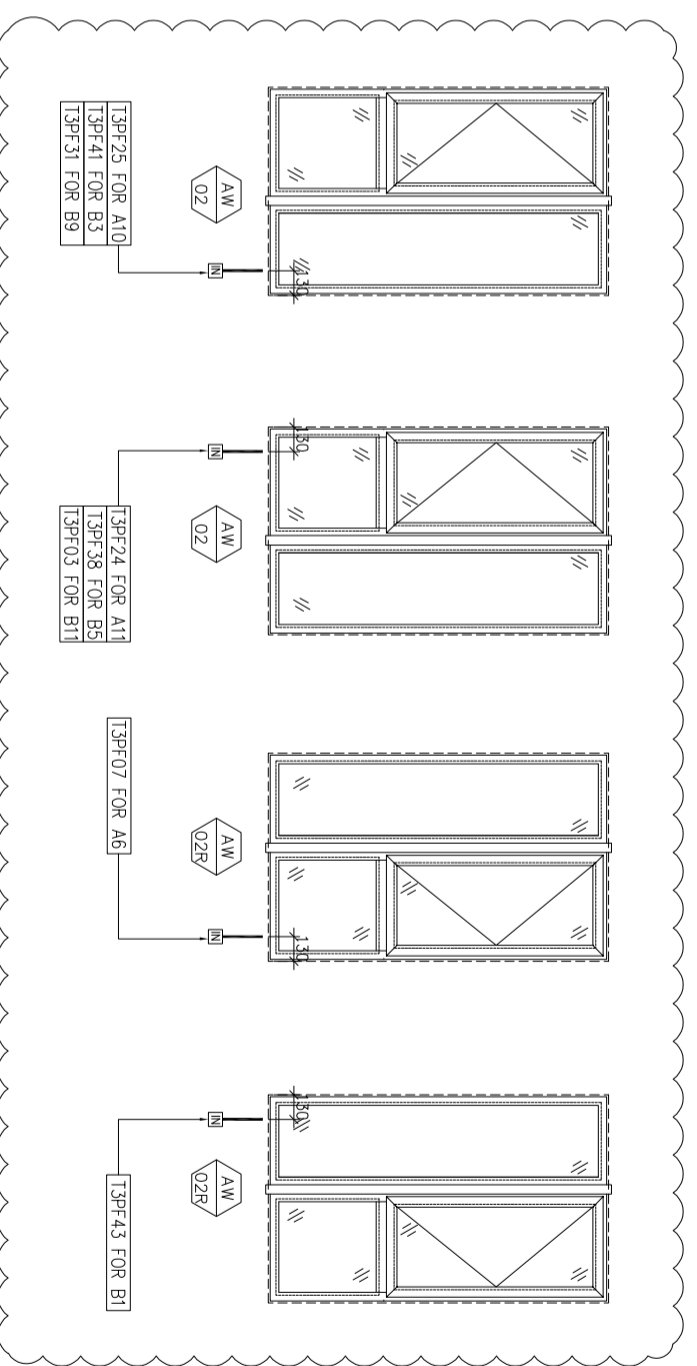
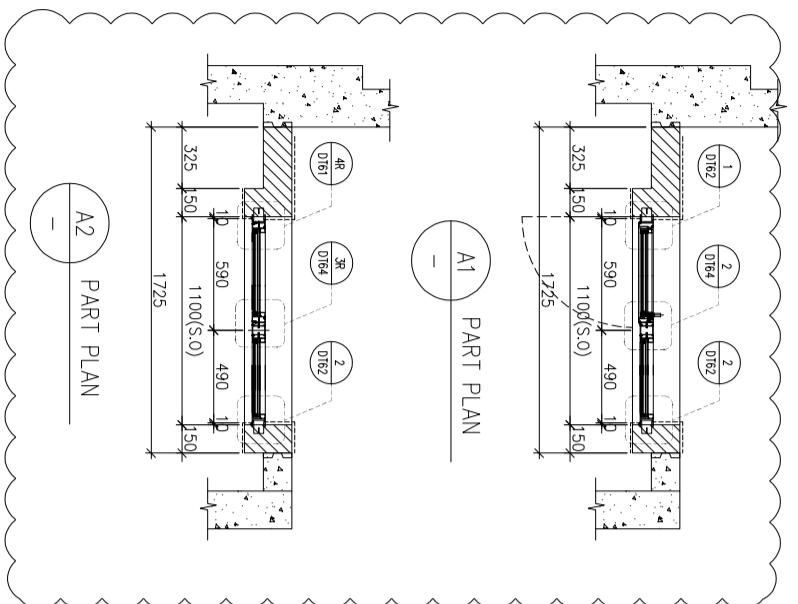
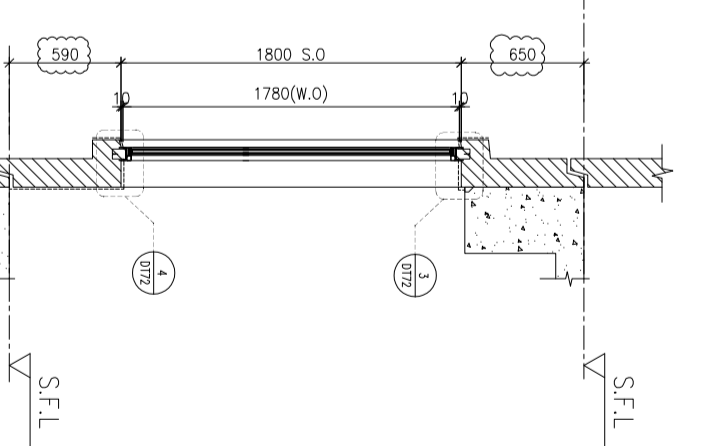
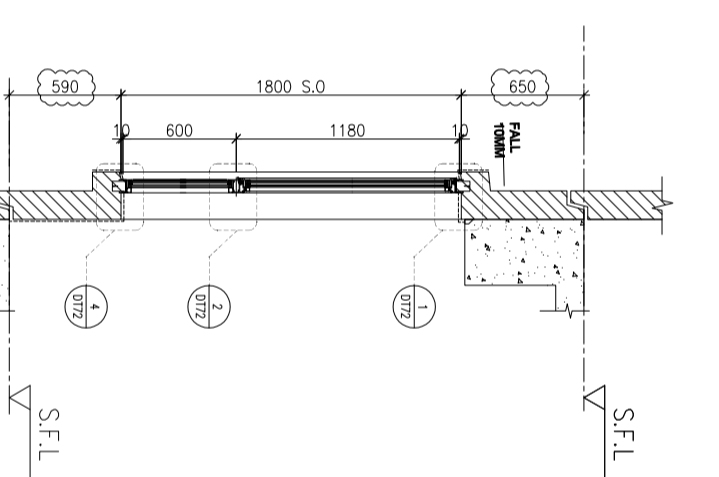
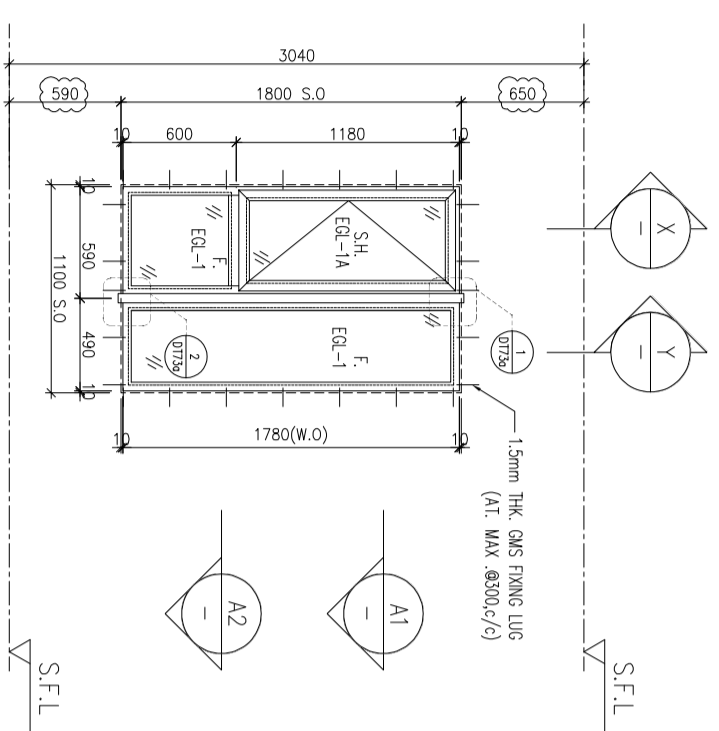

ELEVATION

WINDOW MARK	AW 02
LOCATION	3/F~42/F(4/F,13/F,14/F,24/F,34/F OMITTED) UNIT A10,A11,B3,B5,B11&5/F~42/F FOR B9
SECTION	70mm ALUM. SECTION
GLAZING	EGL-1,EGL-1A
QUANTITY	35 Nos / 35 Nos / 35 Nos / 35 Nos / 35 Nos / 34 Nos
REMARKS	FAÇADE(TYPE T3PF05R FOR 3/F~42/F)

WINDOW MARK	AW 02R
LOCATION	3/F~42/F(4/F,13/F,14/F,24/F,34/F OMITTED) UNIT A6,B1
SECTION	70mm ALUM. SECTION
GLAZING	EGL-1,EGL-1A
QUANTITY	35 Nos / 35 Nos
REMARKS	FAÇADE(TYPE T3PF05 FOR 3/F~42/F)

B.O. REF :

CLIENT :

SUN HUNG KAI
REAL ESTATE AGENCY LTD.
42/F SUN HUNG KAI CENTRE, WANGCHAI, HONGKONG

ARCHITECT :
IWK&partners
a r c h i t e c t s

MAIN CONTRACTOR :
怡輝建築有限公司
Yee Fai Building Contractors Ltd.

STRUCTURAL ENGINEER :
ARUP

FAÇADE CONSULTANT:
ALPHA CONSULTING LIMITED
Steel Structure & Façade Specialist

NOTE :
1. ALL DIMENSIONS ARE IN mm.
2. ALL ELEVATIONS ARE VIEWED FROM OUTSIDE.
3. ALL DIMENSIONS TO BE VERIFIED ON SITE BEFORE FABRICATION.

LEGEND :
X1 --- DETAIL MARK NO.
X001 --- REFER SHEET NO.

1. F.F.L.--FINISHED FLOOR LEVEL
2. S.F.L.--STRUCTURAL FLOOR LEVEL
3. (R) --REVERSED DETAIL
4. GLASS LEGEND
EGL-1--8mmHS+12mm AIR GAP+10mmTP THK. I.G.U.
EGL-2--10mm THK. CLEAR TEMPERED GLASS
EGL-4--10mm THK. TEMPERED ACID ETCHED GLASS
EGL-1A-8mmHS+12mm AIR GAP+8mmTP THK. I.G.U.

NO.	DATE	REVISION SUBJECT TO ARCH/COMMENT	BY
F	14/12/2021	REVISION SUBJECT TO ARCH/COMMENT	NON
E	29/11/2021	REVISION SUBJECT TO ARCH/COMMENT	NON
D	02/11/2021	REVISION SUBJECT TO ARCH/COMMENT	NON
C	28/10/2021	REVISION SUBJECT TO ARCH/COMMENT	NON
B	18/10/2021	REVISION SUBJECT TO ARCH/COMMENT	NON
A	27/09/2021	REVISION SUBJECT TO ARCH/COMMENT	NON

JOB NO. : J-856
PROJECT : PROPOSED DEVELOPMENT ABOVE LIGHT RAIL TIN WING STOP TSWTL NO.23,AREA 33,TIN SHUI WAI, N.T.
TITLE : WINDOW SCHEDULE FOR TOWER 3 ALUM. WINDOW

DATE : 02-Aug-21 SCALE : 1:40
DRAWN BY : IYON CHECKED BY :

美特鋁質有限公司
MIDI ALUMINIUM FABRICATOR LTD.
Units 6-8, Sunny Industrial Centre, 1/F
610 Che Kwo Ling Road, Kowloon
Tel:23489211-4 Fax:95212727666
DWG NO. : 856-SD-PW-5304 REV. : F

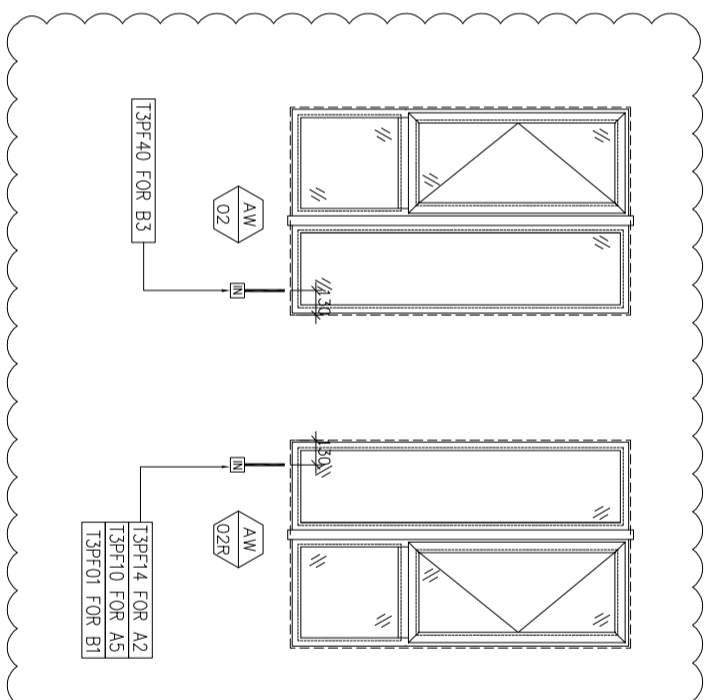
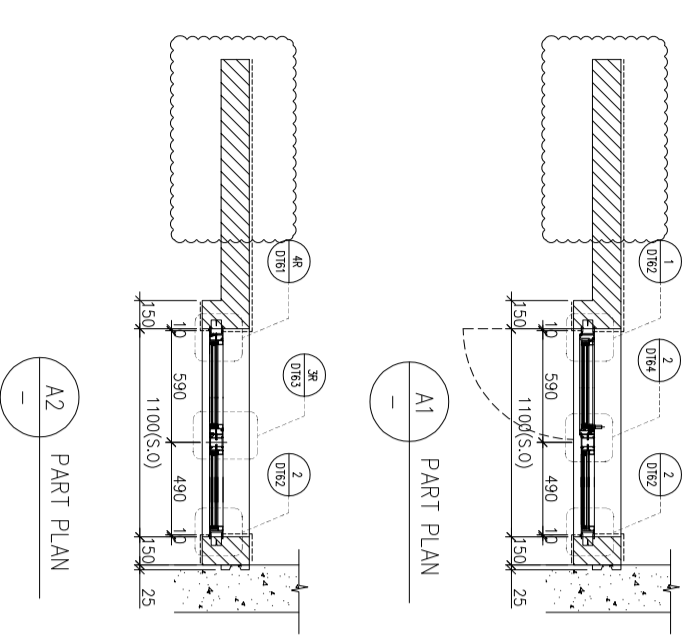
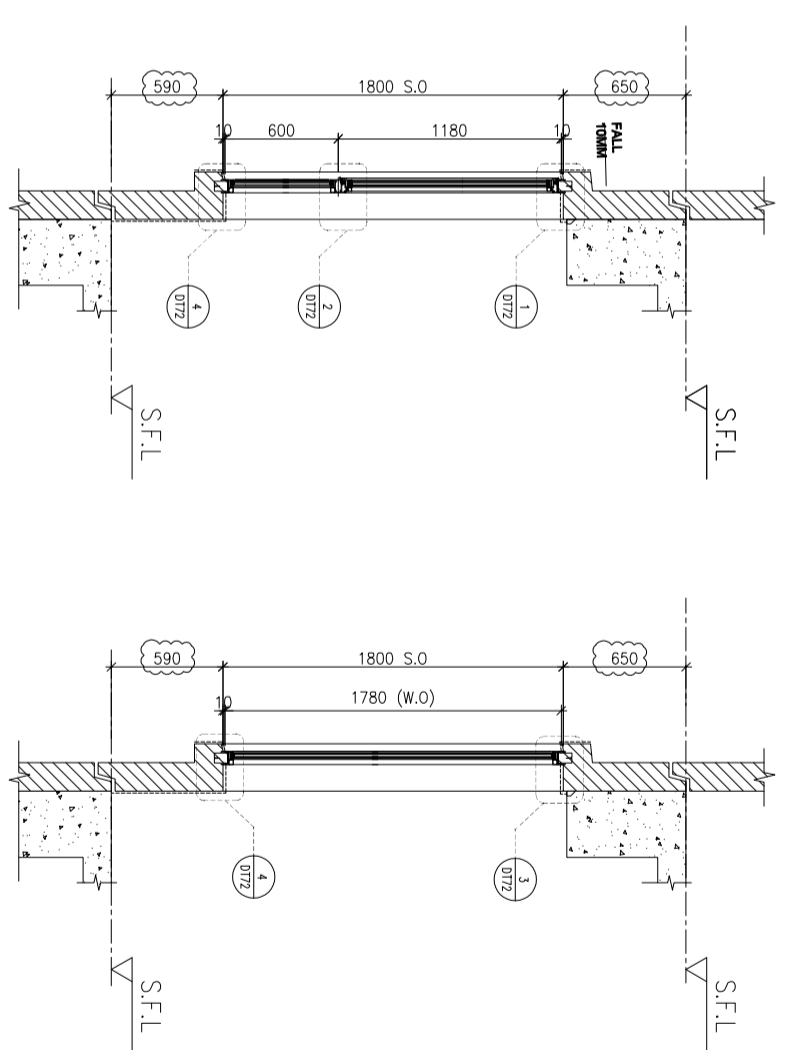
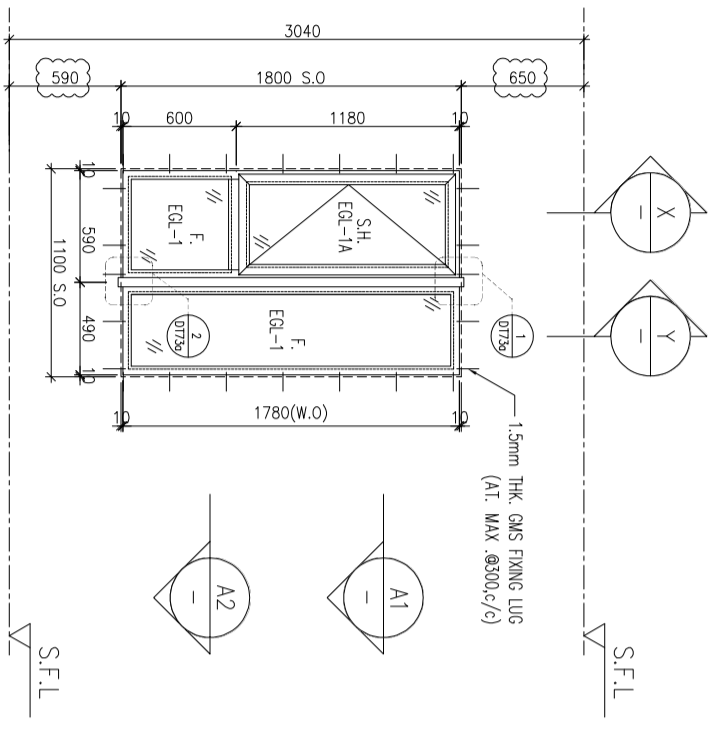

WINDOW MARK	AW 02R	AW 02R
LOCATION	3/F~42/F(4/F,13/F,14/F,24/F,34/F OMITTED) UNIT B3	3/F~42/F(4/F,13/F,14/F,24/F,34/F OMITTED) UNIT A2,A5,B1
SECTION	70mm ALUM. SECTION	70mm ALUM. SECTION
GLAZING	EGL-1,EGL-1A	EGL-1,EGL-1A
QUANTITY	35 Nos	35 Nos / 35 Nos / 35 Nos
REMARKS	FAÇADE(TYPE T3PF08R FOR 3/F~42/F)	FAÇADE(TYPE T3PF08 FOR 3/F~42/F)

ELEVATION

B.O. REF. :

CLIENT :

SUN HUNG KAI
REAL ESTATE AGENCY LTD.
42/F SUN HUNG KAI CENTRE, WANGCHAI, HONGKONG

ARCHITECT :

IWK&partners
a r c h i t e c t s

MAIN CONTRACTOR :

怡輝建築有限公司
Yee Fai Building Contractors Ltd.

STRUCTURAL ENGINEER :

ARUP

FAÇADE CONSULTANT:

ALPHA CONSULTING LIMITED
Steel Structure & Façade Specialist

NOTE :

1. ALL DIMENSIONS ARE IN mm.
2. ALL ELEVATIONS ARE VIEWED FROM OUTSIDE.
3. ALL DIMENSIONS TO BE VERIFIED ON SITE BEFORE FABRICATION.

LEGEND :

(X1) — DETAIL MARK NO.
(X001) — REFER SHEET NO.

1. F.F.L. -- FINISHED FLOOR LEVEL
2. S.F.L. -- STRUCTURAL FLOOR LEVEL
3. (R) -- REVERSED DETAIL

4. GLASS LEGEND

EQ1-1 -- 8mmHS+12mm AIR GAP+10mmTP THK. I.G.U.
 EQ1-2 -- 10mm THK. CLEAR TEMPERED GLASS
 EQ1-4 -- 10mm THK. TEMPERED ACID ETCHED GLASS
 EQ1-1A -- 8mmHS+12mm AIR GAP+8mmTP THK. I.G.U.

NO.	DATE	REVISION SUBJECT TO ARCH COMMENT	BY
F	14/12/2021	REVISION SUBJECT TO ARCH COMMENT	WPN
E	29/11/2021	REVISION SUBJECT TO ARCH COMMENT	WPN
D	02/11/2021	REVISION SUBJECT TO ARCH COMMENT	WPN
C	28/10/2021	REVISION SUBJECT TO ARCH COMMENT	WPN
B	18/10/2021	REVISION SUBJECT TO ARCH COMMENT	WPN
A	27/09/2021	REVISION SUBJECT TO ARCH COMMENT	WPN

JOB NO. : J-856

PROJECT :

PROPOSED DEVELOPMENT ABOVE
LIGHT RAIL TIN WING STOP TSWTL
NO.23, AREA 33, TIN SHUI WAI, N.T.

TITLE :

WINDOW SCHEDULE FOR
TOWER 3 ALUM. WINDOW

DATE : 02-Aug-21 SCALE : 1:40

DRAWN BY : IYON

CHECKED BY :

美特鋁質有限公司
MIDI ALUMINIUM FABRICATOR LTD.
Units 6-8, Sunny Industrial Centre, 1/F
610 Che Kwo Ling Road, Kowloon
Tel: 23489211-4 Fax: (852) 27272666
DWG NO. : 856-SD-PW-5305 REV. : F

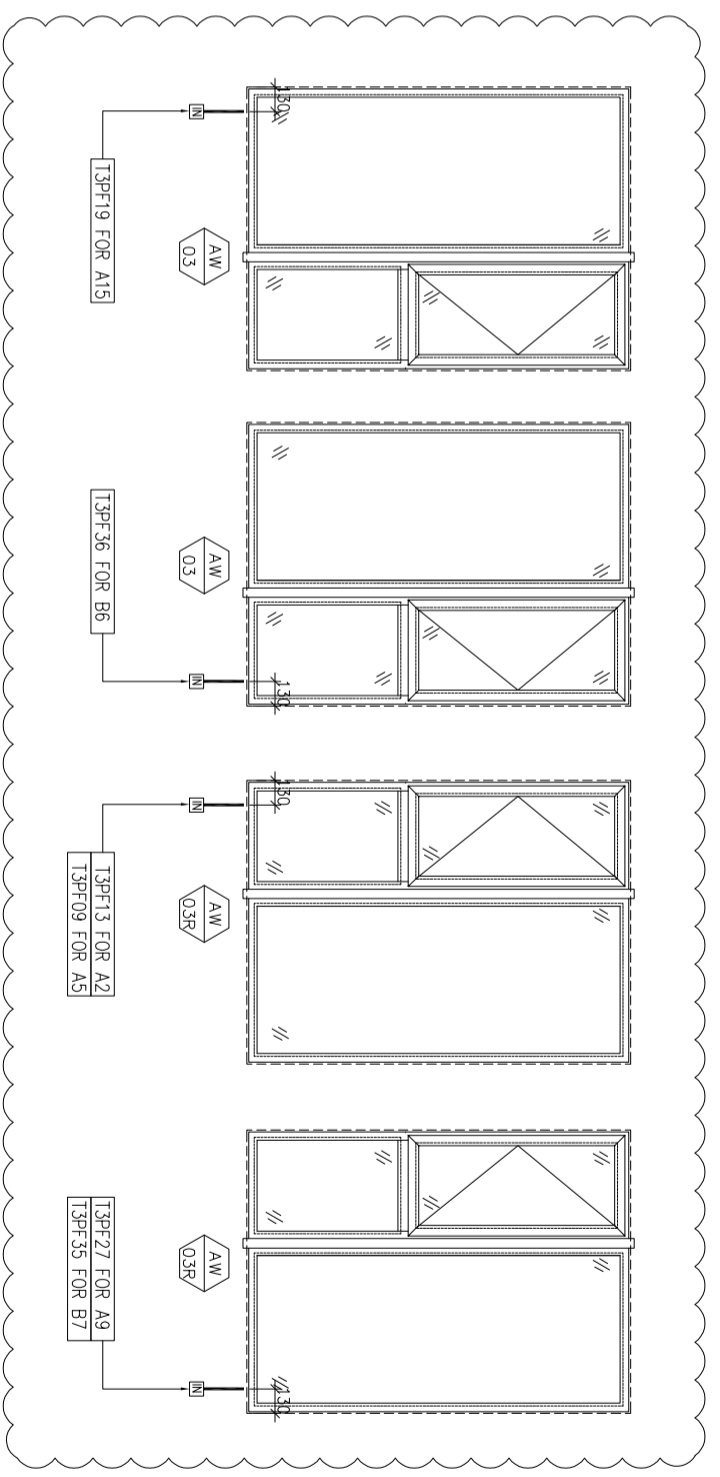
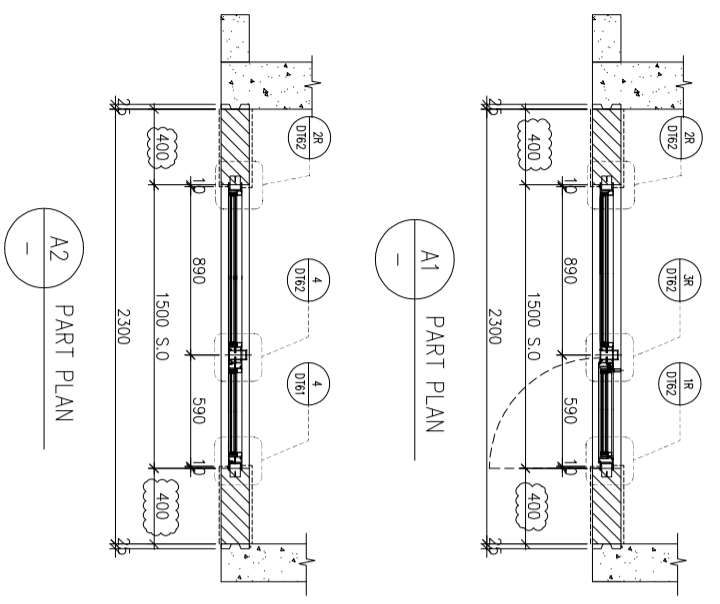
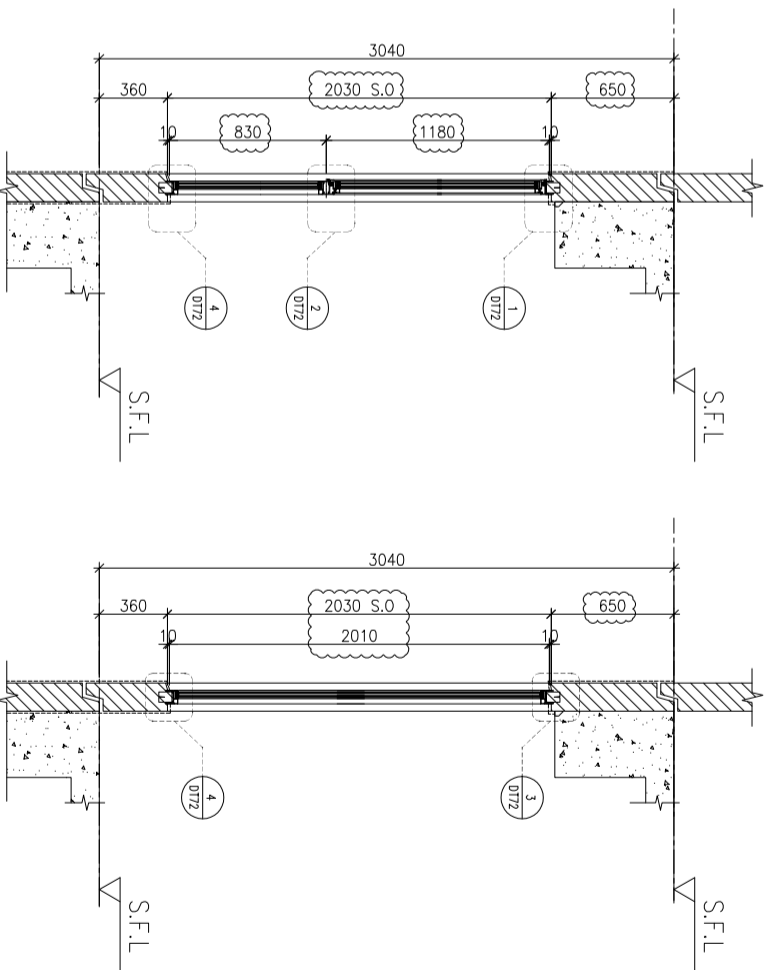
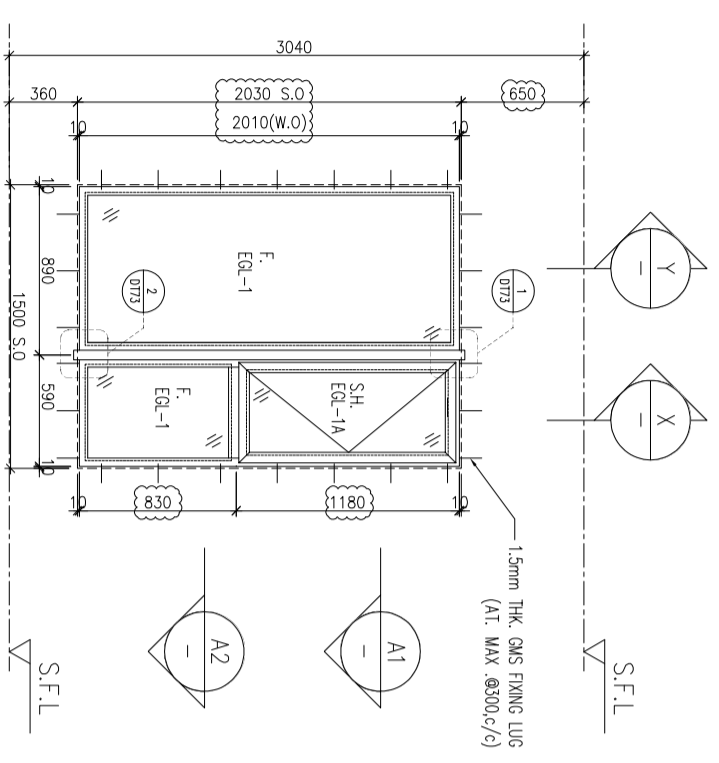

WINDOW MARK	AW 03	AW 03R
LOCATION	3/F~42/F(4/F,13/F,14/F,24/F,34/F OMITTED) UNIT B6 & 5/F~42/F FOR A15	
SECTION	70mm ALUM. SECTION	
GLAZING	EGL-1, EGL-1A	
QUANTITY	35 Nos / 34 Nos	
REMARKS	FAÇADE TYPE T3PF10 FOR 3/F~42/F	

ELEVATION

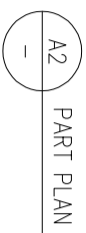
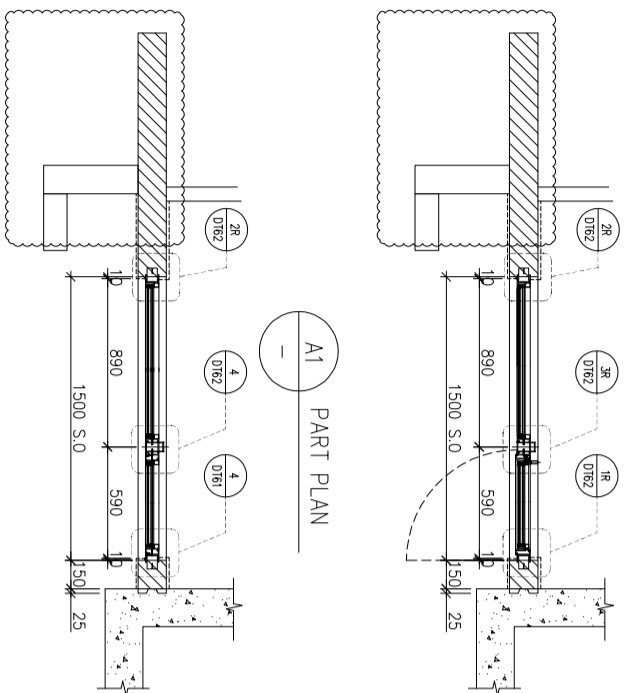
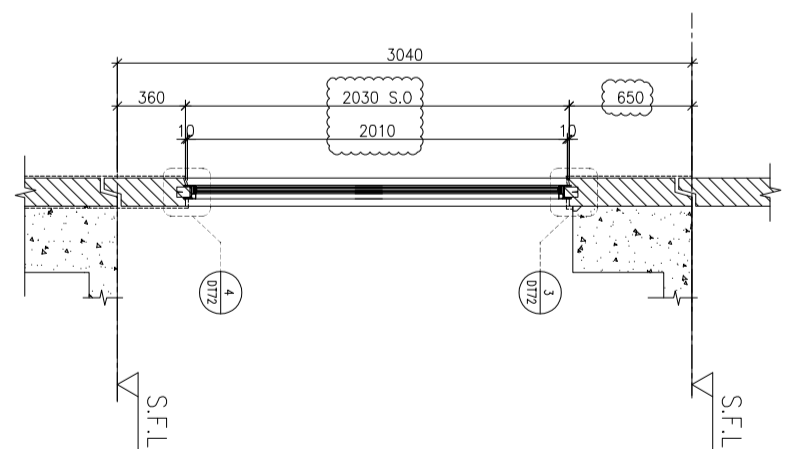
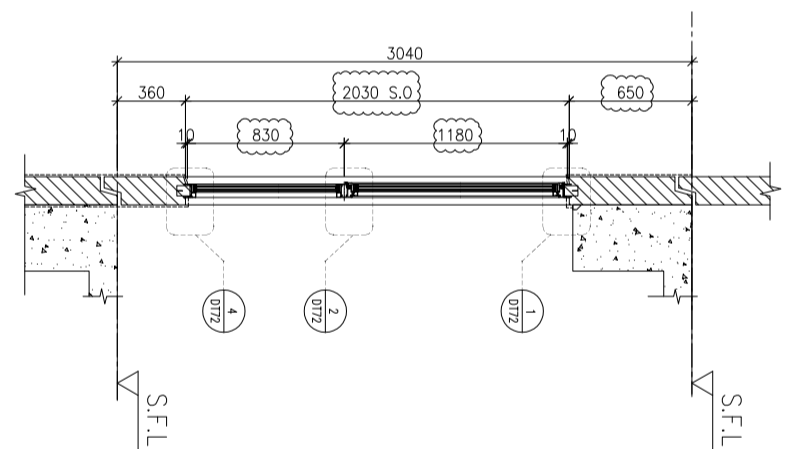
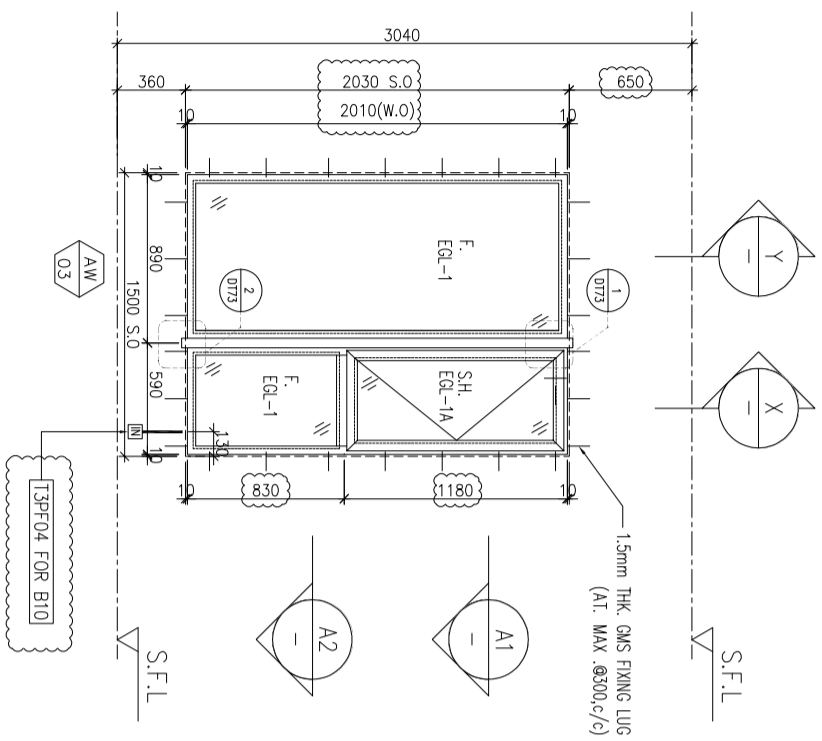

B.O. REF : _____

CLIENT : **SUN HUNG KAI REAL ESTATE AGENCY LTD.**
42/F SUN HUNG KAI CENTRE, WANGCHAI, HONGKONG

ARCHITECT : **IWK&partners**
a r c h i t e c t s

MAIN CONTRACTOR : **怡輝建築有限公司**
Yee Fai Building Contractors Ltd.

STRUCTURAL ENGINEER : **ARUP**

FAÇADE CONSULTANT : **ALPHA CONSULTING LIMITED**
Steel Structure & Façade Specialist

NOTE :
1. ALL DIMENSIONS ARE IN mm.
2. ALL ELEVATIONS ARE VIEWED FROM OUTSIDE.
3. ALL DIMENSIONS TO BE VERIFIED ON SITE BEFORE FABRICATION.

LEGEND :
X1 --- DETAIL MARK NO.
X001 --- REFER SHEET NO.

1. F.F.L.--FINISHED FLOOR LEVEL
2. S.F.L.--STRUCTURAL FLOOR LEVEL
3. (R) --REVERSED DETAIL

4. GLASS LEGEND
EQL-1--8mmHS+12mm AIR GAP+10mmTP THK. I.G.U.
EQL-2--10mm THK. CLEAR TEMPERED GLASS
EQL-4--10mm THK. TEMPERED ACID ETCHED GLASS
EQL-1A-8mmHS+12mm AIR GAP+8mmTP THK. I.G.U.

NO.	DATE	REVISION	REVISION SUBJECT TO ARCH COMMENT
E	14/12/2021	REVISION SUBJECT TO ARCH COMMENT	None
D	29/11/2021	REVISION SUBJECT TO ARCH COMMENT	None
C	02/11/2021	REVISION SUBJECT TO ARCH COMMENT	None
B	29/10/2021	REVISION SUBJECT TO ARCH COMMENT	None
A	27/09/2021	REVISION SUBJECT TO ARCH COMMENT	None

JOB NO. : J-856

PROJECT : PROPOSED DEVELOPMENT ABOVE LIGHT RAIL TIN WING STOP TSWTL NO.23,AREA 33,TIN SHUI WAI, N.T.

TITLE : WINDOW SCHEDULE FOR TOWER 3 ALUM. WINDOW

DATE : 02-Aug-21 SCALE : 1:40

DRAWN BY : Ivorn CHECKED BY :

WINDOW MARK	AW 03
LOCATION	3/F~42/F,4/F,13/F,14/F,24/F,34/F OMITTED) UNIT B10
SECTION	70mm ALUM. SECTION
GLAZING	EGL-1,EGL-1A
QUANTITY	35 Nos
REMARKS	FAÇADE TYPE T3PF11R FOR 3/F~42/F

UNITED BUILDING SERVICES LIMITED
MIDI ALUMINIUM FABRICATOR LTD.
Units 6-8, Sunny Industrial Centre, 1/F
610 Che Kwo Ling Road, Kowloon
Tel:23489211-4 Fax:85227272666

DWG NO. : 856-SD-PW-5306 REV. : E

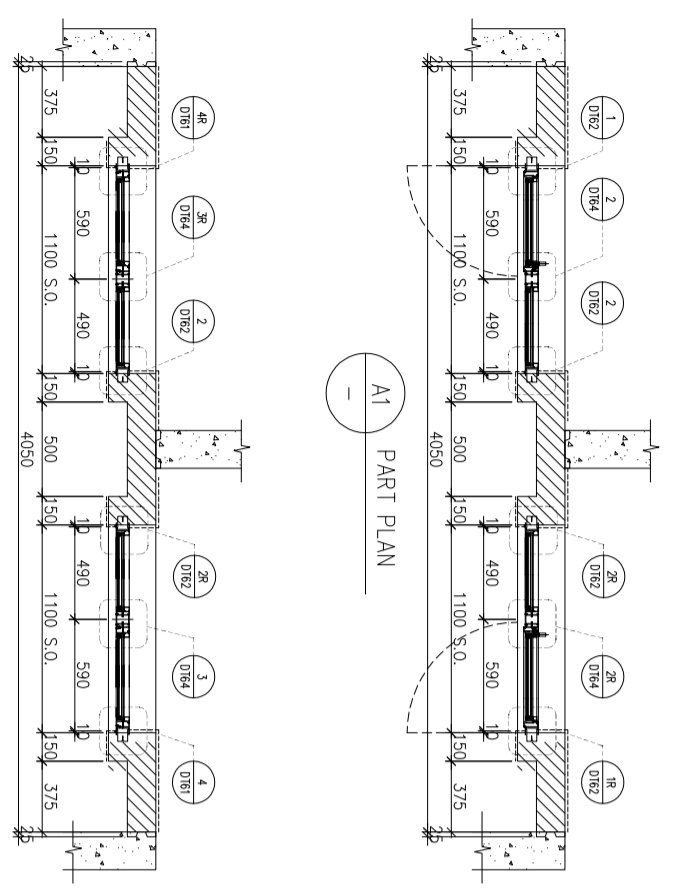
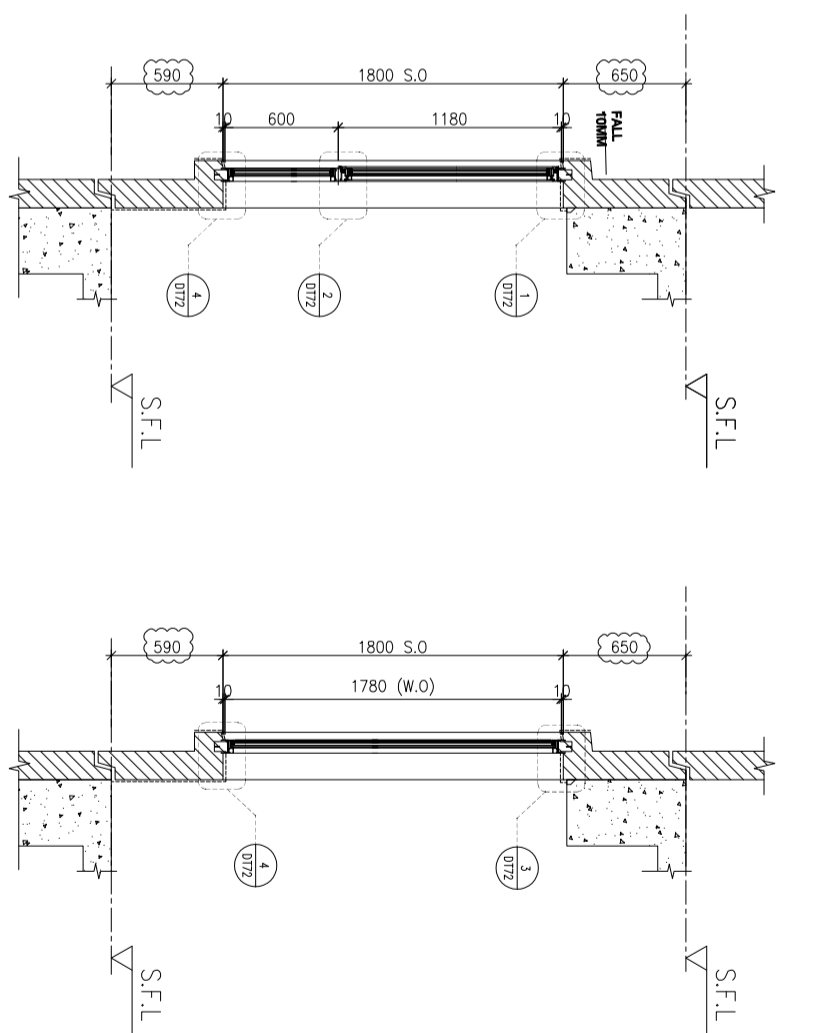
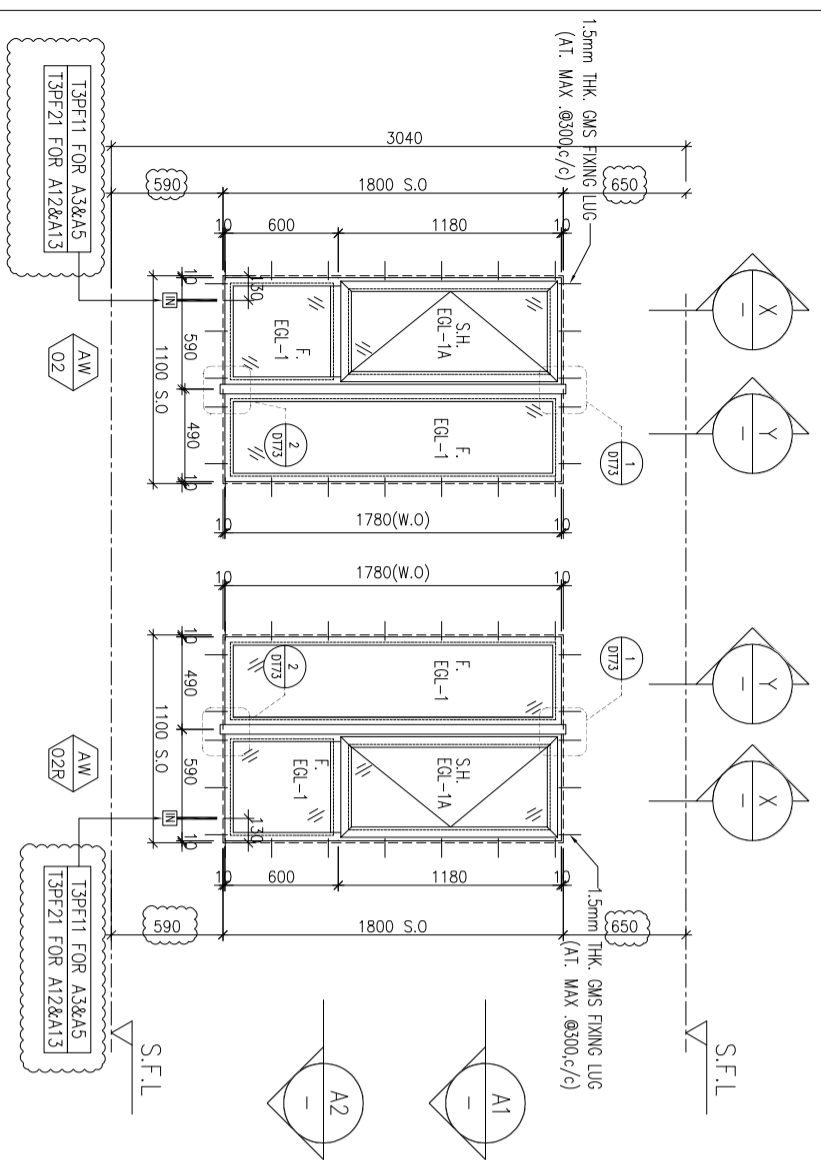

WINDOW MARK	AW 02	AW 02R
LOCATION	3/F~42/F/4/F.13/F.14/F.24/F.34/F OMITTED) UNIT A3&A5, A12&A13	
SECTION	70mm ALUM. SECTION	
GLAZING	EGL-1, EGL-1A	
QUANTITY	35 Nos / 35 Nos	
REMARKS	FACADETYPE T3PF16 FOR 3/F~42/F)	

B.O. REF : _____

CLIENT : **SUN HUNG KAI REAL ESTATE AGENCY LTD.**
42/F SUN HUNG KAI CENTRE, WANGCHAI, HONGKONG

ARCHITECT : **IWK&partners**
a r c h i t e c t s

MAIN CONTRACTOR : **怡輝建築有限公司**
Yee Fai Building Contractors Ltd.

STRUCTURAL ENGINEER : **ARUP**

FACADE CONSULTANT : **ALPHA CONSULTING LIMITED**
Steel Structure & Facade Specialist

NOTE :
1. ALL DIMENSIONS ARE IN mm.
2. ALL ELEVATIONS ARE VIEWED FROM OUTSIDE.
3. ALL DIMENSIONS TO BE VERIFIED ON SITE BEFORE FABRICATION.

LEGEND :
X1 --- DETAIL MARK NO.
X001 --- REFER SHEET NO.

1. F.F.L.--FINISHED FLOOR LEVEL
2. S.F.L.--STRUCTURAL FLOOR LEVEL
3. (R) --REVERSED DETAIL
4. GLASS LEGEND
EGL-1--8mmHS+12mm AIR GAP+10mmTP THK. I.G.U.
EGL-2--10mm THK. CLEAR TEMPERED GLASS
EGL-4--10mm THK. TEMPERED ACID ETCHED GLASS
EGL-1A-8mmHS+12mm AIR GAP+8mmTP THK. I.G.U.

NO.	DATE	REVISION SUBJECT TO ARCH COMMENT	BY	REMSD
F	14/12/2021	REVISION SUBJECT TO ARCH COMMENT	lvan	
E	29/11/2021	REVISION SUBJECT TO ARCH COMMENT	lvan	
D	02/11/2021	REVISION SUBJECT TO ARCH COMMENT	lvan	
C	28/10/2021	REVISION SUBJECT TO ARCH COMMENT	lvan	
B	18/10/2021	REVISION SUBJECT TO ARCH COMMENT	lvan	
A	27/09/2021	REVISION SUBJECT TO ARCH COMMENT	lvan	

JOB NO. : J-856

PROJECT : PROPOSED DEVELOPMENT ABOVE LIGHT RAIL TIN WING STOP TSWTL NO.23,AREA 33,TIN SHUI WAI, N.T.

TITLE : WINDOW SCHEDULE FOR TOWER 3 ALUM. WINDOW

DATE : 02-Aug-21 SCALE : 1:40

DRAWN BY : lvan CHECKED BY : _____

Units 6-8, Sunny Industrial Centre, 1/F
610 Che Kwo Ling Road, Kowloon
Tel:23489211-4 Fax:85227272666

美特鋁質有限公司
MIDI ALUMINIUM FABRICATOR LTD.

DWG NO. : 0856-SD-PW-5308 REV. : F

B.O. REF :

CLIENT :

SUN HUNG KAI
REAL ESTATE AGENCY LTD.
42/F SUN HUNG KAI CENTRE, WANGCHAI, HONGKONG

ARCHITECT :

IWK&partners
a r c h i t e c t s

MAIN CONTRACTOR :

怡輝建築有限公司
Yee Fai Building Contractors Ltd.

STRUCTURAL ENGINEER :

ARUP

FAÇADE CONSULTANT:

ALPHA CONSULTING LIMITED
Steel Structure & Façade Specialist

NOTE :

1. ALL DIMENSIONS ARE IN mm.
2. ALL ELEVATIONS ARE VIEWED FROM OUTSIDE.
3. ALL DIMENSIONS TO BE VERIFIED ON SITE BEFORE FABRICATION.

LEGEND :

- (X1) --- DETAIL MARK NO.
- (X001) --- REFER SHEET NO.

1. F.F.L.--FINISHED FLOOR LEVEL
2. S.F.L.--STRUCTURAL FLOOR LEVEL
3. (R) --REVERSED DETAIL

4. GLASS LEGEND

EQ1-1--8mmHS+12mm AIR GAP+10mmTP THK. I.G.U.
 EQ1-2--10mm THK. CLEAR TEMPERED GLASS
 EQ1-4--10mm THK. TEMPERED ACID ETCHED GLASS
 EQ1-1A-8mmHS+12mm AIR GAP+8mmTP THK. I.G.U.

NO.	DATE	REVISION SUBJECT TO ARCH COMMENT	BY
F	14/12/2021	REVISION SUBJECT TO ARCH COMMENT	hvn
E	29/11/2021	REVISION SUBJECT TO ARCH COMMENT	hvn
D	02/11/2021	REVISION SUBJECT TO ARCH COMMENT	hvn
C	28/10/2021	REVISION SUBJECT TO ARCH COMMENT	hvn
B	18/10/2021	REVISION SUBJECT TO ARCH COMMENT	hvn
A	27/09/2021	REVISION SUBJECT TO ARCH COMMENT	hvn

JOB NO. : J-856

PROJECT :

PROPOSED DEVELOPMENT ABOVE
LIGHT RAIL TIN WING STOP TSWTL
NO.23,AREA 33,TIN SHUI WAI, N.T.

TITLE :

WINDOW SCHEDULE FOR
TOWER 3 ALUM. WINDOW

DATE : 02-Aug-21 SCALE : 1:40

DRAWN BY : lvon CHECKED BY :

美特鋁質有限公司
MIDI ALUMINIUM FABRICATOR LTD.
Units 6-8, Sunny Industrial Centre, 1/F
610 Che Kwo Ling Road, Kowloon
Tel:23489211-4 Fax:95212727666

DWG NO. : 856-SD-PW-5309 REV. : F

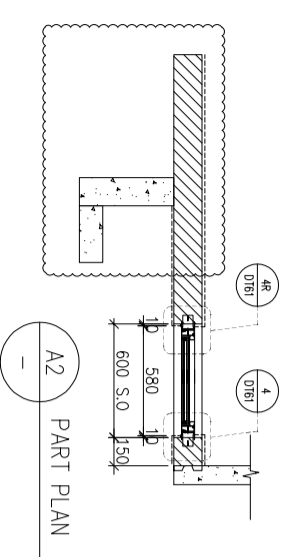
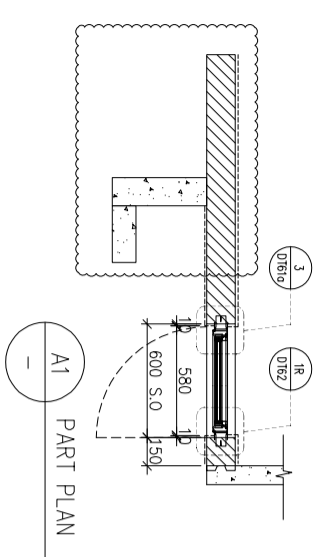
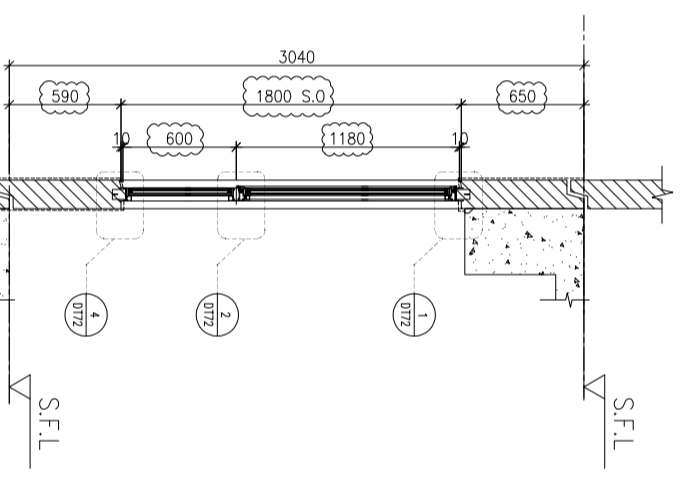
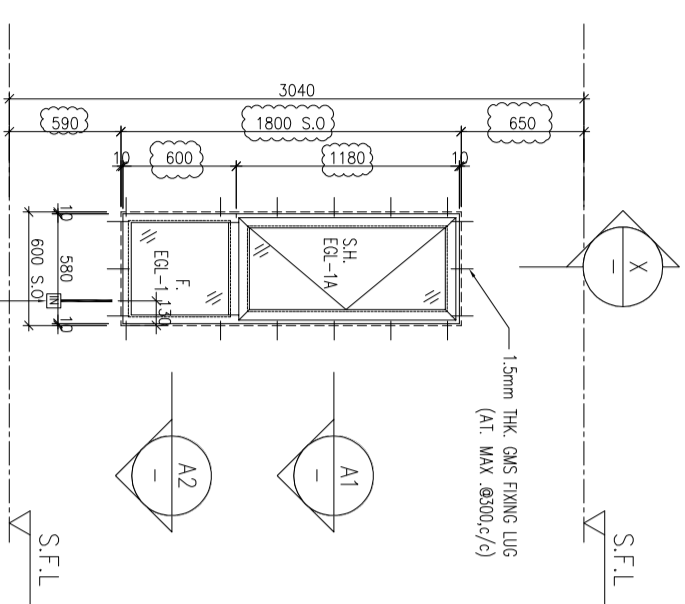

ELEVATION

WINDOW MARK



LOCATION

3/F~42/F/4/F.13/F.14/F.24/F.34/F OMITTED) UNIT B2

SECTION

70mm ALUM. SECTION

GLAZING

EGL-1,EGL-1A

QUANTITY

35 Nos

REMARKS

FAÇADE TYPE TSPF18 FOR 3/F~42/F)

B.O. REF :

CLIENT :

SUN HUNG KAI
REAL ESTATE AGENCY LTD.
42/F SUN HUNG KAI CENTRE, WANCHAI, HONGKONG

ARCHITECT :

Iwk&partners
a r c h i t e c t s

MAIN CONTRACTOR :

怡輝建築有限公司
Yee Fai Building Contractors Ltd.

STRUCTURAL ENGINEER :

ARUP

FAÇADE CONSULTANT:

ALPHA CONSULTING LIMITED
Steel Structure & Façade Specialist

NOTE :

1. ALL DIMENSIONS ARE IN mm.
2. ALL ELEVATIONS ARE VIEWED FROM OUTSIDE.
3. ALL DIMENSIONS TO BE VERIFIED ON SITE BEFORE FABRICATION.

LEGEND :

- (X1) --- DETAIL MARK NO.
- (X001) --- REFER SHEET NO.

1. F.F.L. --- FINISHED FLOOR LEVEL
2. S.F.L. --- STRUCTURAL FLOOR LEVEL
3. (R) --- REVERSED DETAIL

4. GLASS LEGEND

- EG1-1 --- 8mmHS+12mm AIR GAP+10mmTP THK. I.G.U.
- EG1-2 --- 10mm THK. CLEAR TEMPERED GLASS
- EG1-4 --- 10mm THK. TEMPERED ACID ETCHED GLASS
- EG1-1A --- 8mmHS+12mm AIR GAP+8mmTP THK. I.G.U.

NO.	DATE	REVISION SUBJECT TO ARCH COMMENT	BY
D	14/12/2021	REVISION SUBJECT TO ARCH COMMENT	lvm
C	29/11/2021	REVISION SUBJECT TO ARCH COMMENT	lvm
B	18/10/2021	REVISION SUBJECT TO ARCH COMMENT	lvm
A	12/10/2021	REVISION SUBJECT TO ARCH COMMENT	lvm

JOB NO. : J-856

PROJECT :

PROPOSED DEVELOPMENT ABOVE LIGHT RAIL TIN WING STOP TSWTL NO.23, AREA 33, TIN SHUI WAI, N.T.

TITLE : WINDOW SCHEDULE FOR TOWER 3 ALUM. WINDOW

DATE : 02-Aug-21 SCALE : 1:40

DRAWN BY : lvm CHECKED BY :

美特鋁質有限公司
MIDI ALUMINIUM FABRICATOR LTD.
Units 6-8, Sunny Industrial Centre, 1/F
610 Che Kwo Ling Road, Kowloon
Tel:23489211-4 Fax:85227272666
DWG NO. : 856-SD-PW-5310 REV. : D

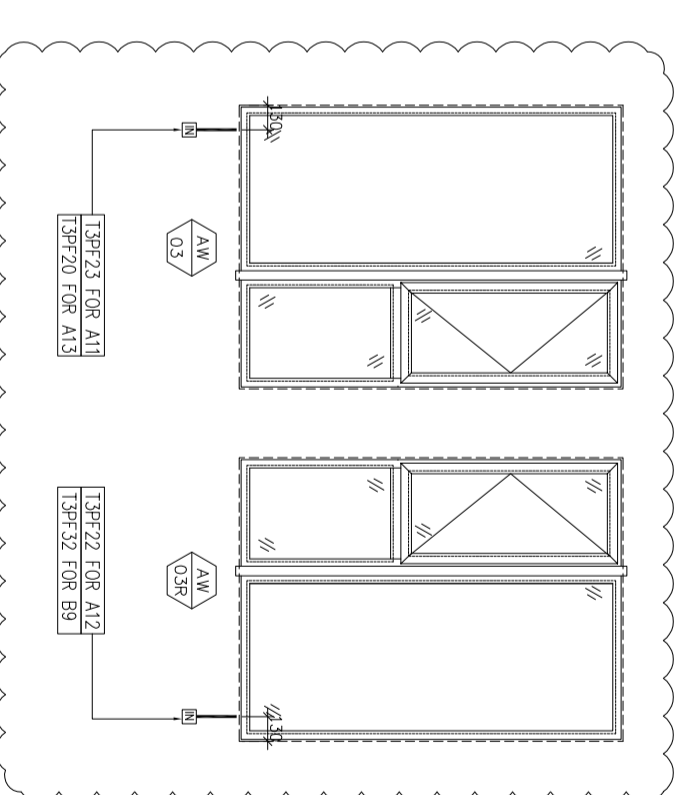
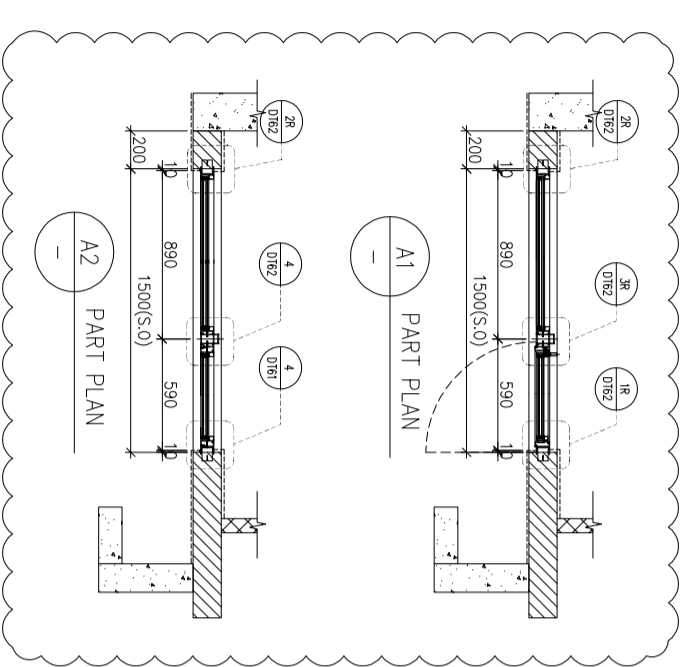
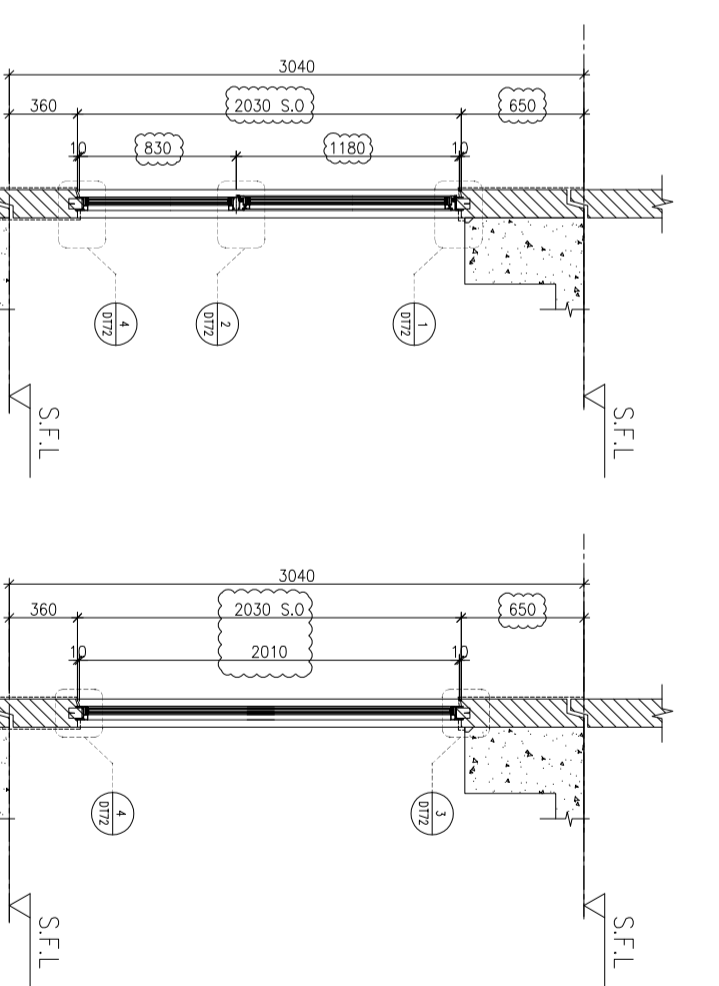
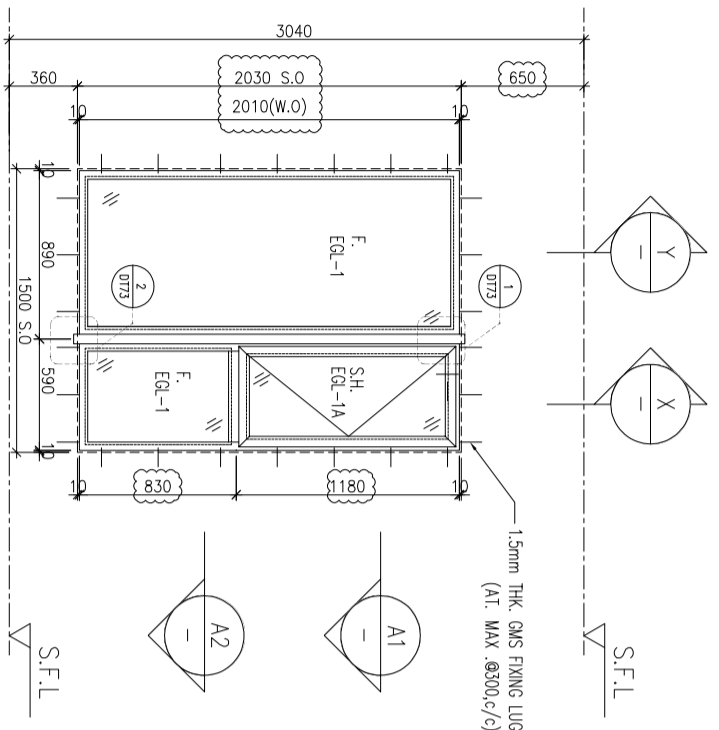

ELEVATION

WINDOW MARK	AW 03
LOCATION	3/F~42/F(4/F,13/F,14/F,24/F,34/F OMITTED) UNIT A11,A13
SECTION	70mm ALUM. SECTION
GLAZING	EGL-1,EGL-1A
QUANTITY	35 Nos
REMARKS	FAÇADE(TYPE T3PF04 FOR 3/F~42/F)

WINDOW MARK	AW 03R
LOCATION	3/F~42/F(4/F,13/F,14/F,24/F,34/F OMITTED) UNIT A12 ,B9
SECTION	70mm ALUM. SECTION
GLAZING	EGL-1,EGL-1A
QUANTITY	35 Nos/35 Nos
REMARKS	FAÇADE(TYPE T3PF04R FOR 3/F~42/F)

B.O. REF :

CLIENT :

SUN HUNG KAI
REAL ESTATE AGENCY LTD.
42/F SUN HUNG KAI CENTRE, WANGCHAI, HONGKONG

ARCHITECT :

IWK&partners
a r c h i t e c t s

MAIN CONTRACTOR :

怡輝建築有限公司
Yee Fai Building Contractors Ltd.

STRUCTURAL ENGINEER :

ARUP

FAÇADE CONSULTANT:

ALPHA CONSULTING LIMITED
Steel Structure & Façade Specialist

NOTE :

1. ALL DIMENSIONS ARE IN mm.
2. ALL ELEVATIONS ARE VIEWED FROM OUTSIDE.
3. ALL DIMENSIONS TO BE VERIFIED ON SITE BEFORE FABRICATION.

LEGEND :

- X1 --- DETAIL MARK NO.
- X001 --- REFER SHEET NO.

1. F.F.L.--FINISHED FLOOR LEVEL
2. S.F.L.--STRUCTURAL FLOOR LEVEL
3. (R) --REVERSED DETAIL

4. GLASS LEGEND

- EQI-1--8mmHS+12mm AIR GAP+10mmTP THK. I.G.U.
- EQI-2--10mm THK. CLEAR TEMPERED GLASS
- EQI-4--10mm THK. TEMPERED ACID ETCHED GLASS
- EQI-1A-8mmHS+12mm AIR GAP+8mmTP THK. I.G.U.

NO.	DATE	REVISION
C	14/12/2021	REVISION SUBJECT TO ARCH.COMMENT
B	29/11/2021	REVISION SUBJECT TO ARCH.COMMENT
A	18/10/2021	REVISION SUBJECT TO ARCH.COMMENT

JOB NO. : J-856

PROJECT :

PROPOSED DEVELOPMENT ABOVE
LIGHT RAIL TIN WING STOP TSWTL
NO.23,AREA 33,TIN SHUI WAI, N.T.

TITLE :

WINDOW SCHEDULE FOR
TOWER 3 ALUM. WINDOW

DATE : 02-Aug-21 SCALE : 1:40

DRAWN BY : Ivon CHECKED BY :

美特鋁質有限公司
MIDI ALUMINIUM FABRICATOR LTD.
Units 6-8, Sunny Industrial Centre, 1/F
610 Che Kwo Ling Road, Kowloon
Tel:23489211-4 Fax:95212727666

DWG NO. : 856-SD-PW-5311 REV. : C

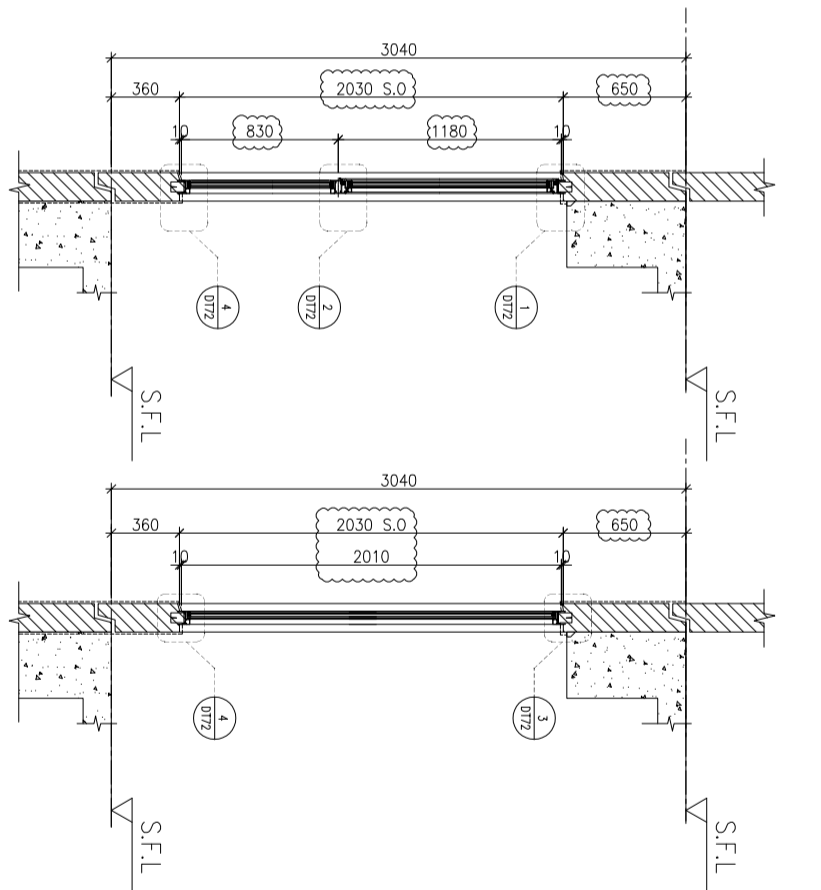
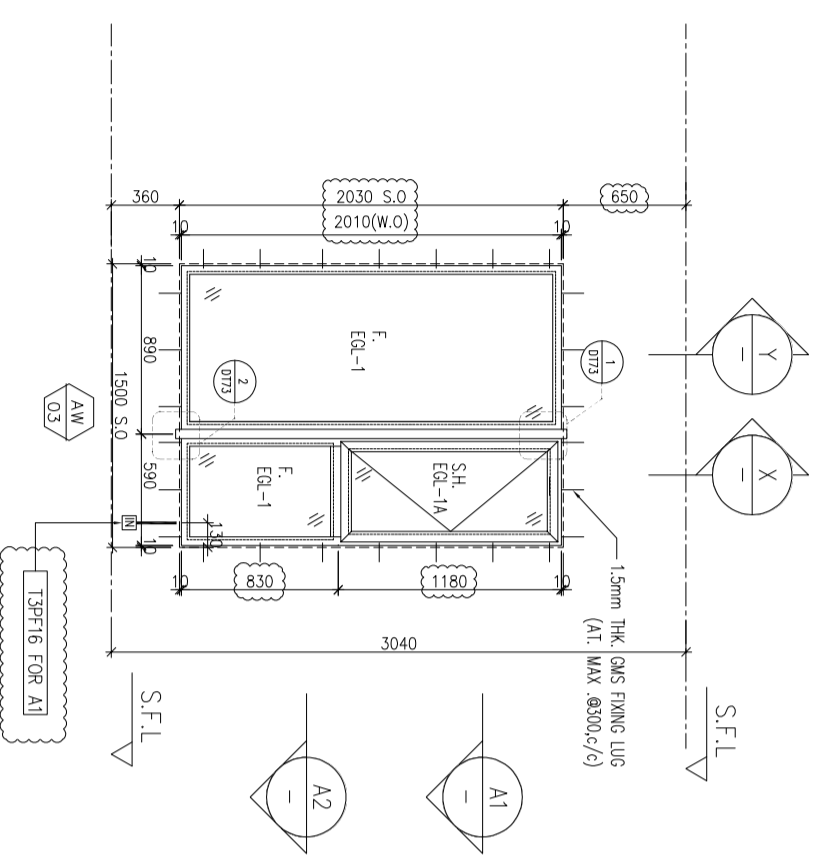

A1 PART PLAN

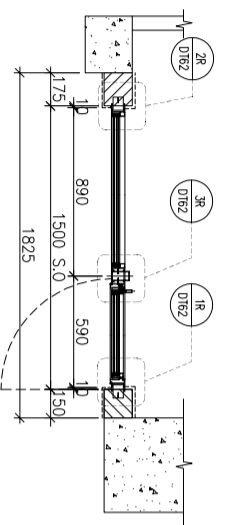

A2 PART PLAN

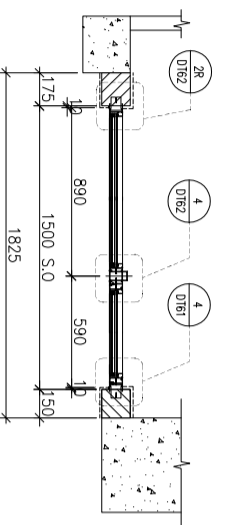

ELEVATION

WINDOW MARK	AW 03
LOCATION	3/F~42/F, 4/F, 13/F, 14/F, 24/F, 34/F OMITTED) UNIT A1
SECTION	70mm ALUM. SECTION
GLAZING	EQI-1, EQI-1A
QUANTITY	35 Nos
REMARKS	FAÇADE TYPE T3PF15 FOR 3/F~42/F)

B.O. REF :

CLIENT :

SUN HUNG KAI
REAL ESTATE AGENCY LTD.
42/F SUN HUNG KAI CENTRE, WANGCHAI, HONGKONG

ARCHITECT :

IWK&partners
a r c h i t e c t s

MAIN CONTRACTOR :

怡輝建築有限公司
Yee Fai Building Contractors Ltd.

STRUCTURAL ENGINEER :

ARUP

FAÇADE CONSULTANT:

ALPHA CONSULTING LIMITED
Steel Structure & Façade Specialist

NOTE :

1. ALL DIMENSIONS ARE IN mm.
2. ALL ELEVATIONS ARE VIEWED FROM OUTSIDE.
3. ALL DIMENSIONS TO BE VERIFIED ON SITE BEFORE FABRICATION.

LEGEND :

- X1 --- DETAIL MARK NO.
- X001 --- REFER SHEET NO.
- 1. F.F.L.--FINISHED FLOOR LEVEL
- 2. S.F.L.--STRUCTURAL FLOOR LEVEL
- 3. (R) ---REVERSED DETAIL
- 4. GLASS LEGEND

EQI-1--8mmHS+12mm AIR GAP+10mmTP THK. I.G.U.
 EQI-2--10mm THK. CLEAR TEMPERED GLASS
 EQI-4--10mm THK. TEMPERED ACID ETCHED GLASS
 EQI-1A-8mmHS+12mm AIR GAP+8mmTP THK. I.G.U.

NO.	DATE	REVISION SUBJECT TO ARCH COMMENT	BY
B	14/12/2021	REVISION SUBJECT TO ARCH COMMENT	hvn
A	18/10/2021	REVISION SUBJECT TO ARCH COMMENT	hvn

JOB NO. : J-856

PROJECT :

PROPOSED DEVELOPMENT ABOVE
LIGHT RAIL TIN WING STOP TSWTL
NO.23,AREA 33,TIN SHUI WAI, N.T.

TITLE :

WINDOW SCHEDULE FOR
TOWER 3 ALUM. WINDOW

DATE : 02-Aug-21 SCALE : 1:40

DRAWN BY : Ivorn CHECKED BY :

美特鋁質有限公司
MIDI ALUMINIUM FABRICATOR LTD.
Units 6-8, Sunny Industrial Centre, 1/F
610 Che Kwo Ling Road, Kowloon
Tel:23489211-4 Fax:9527272666

DWG NO. : 856-SD-PW-5312 REV. : B

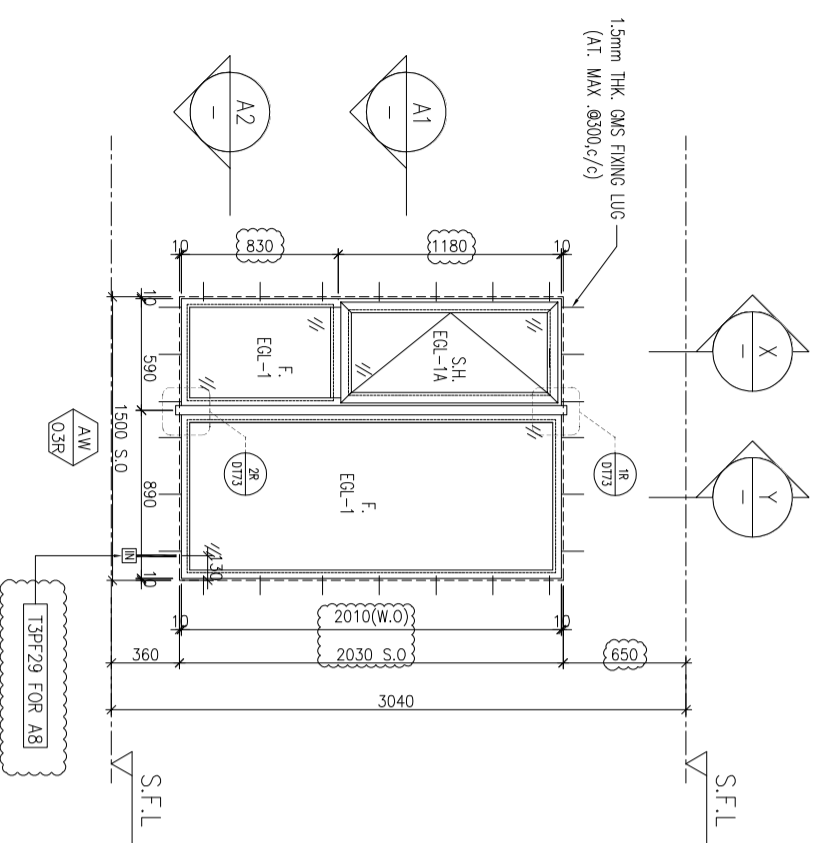

X PART SECTION

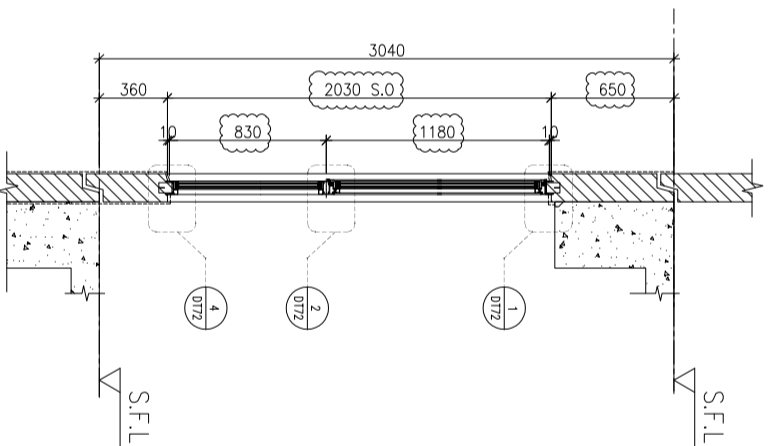

Y PART SECTION

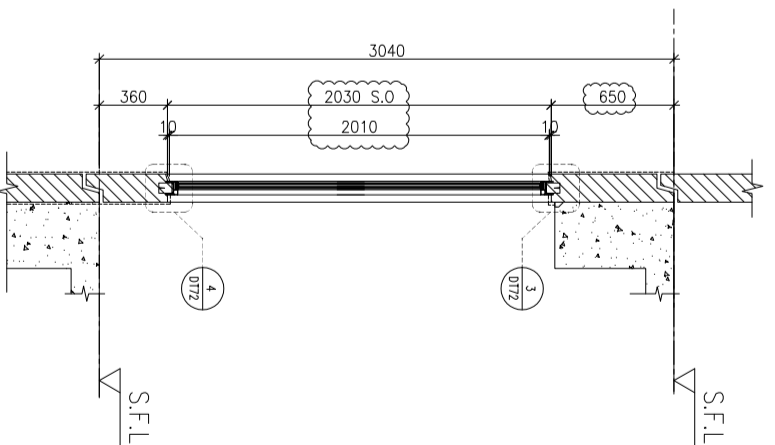

A1 PART PLAN

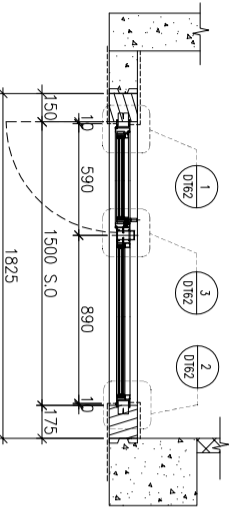

A2 PART PLAN

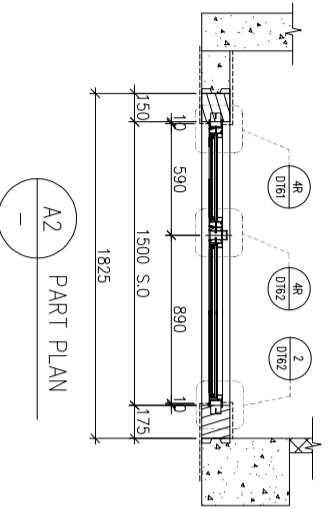

ELEVATION

WINDOW MARK	AW 035F
LOCATION	3/F~42/F/4/F.13/F.14/F.24/F.34/F OMITTED) UNIT A8
SECTION	70mm ALUM. SECTION
GLAZING	EGL-1,EGL-1A
QUANTITY	35 Nos
REMARKS	FAÇADE(TYPE T3PF10 FOR 3/F~42/F)

B.O. REF :

CLIENT :

SUN HUNG KAI
REAL ESTATE AGENCY LTD.
42/F SUN HUNG KAI CENTRE, WANGCHAI, HONGKONG

ARCHITECT :

IWK&partners
a r c h i t e c t s

MAIN CONTRACTOR :

怡輝建築有限公司
Yee Fai Building Contractors Ltd.

STRUCTURAL ENGINEER :

ARUP

FAÇADE CONSULTANT:

ALPHA CONSULTING LIMITED
Steel Structure & Façade Specialist

NOTE :

1. ALL DIMENSIONS ARE IN mm.
2. ALL ELEVATIONS ARE VIEWED FROM OUTSIDE.
3. ALL DIMENSIONS TO BE VERIFIED ON SITE BEFORE FABRICATION.

LEGEND :

(X1) --- DETAIL MARK NO.
(X001) --- REFER SHEET NO.

1. F.F.L. -- FINISHED FLOOR LEVEL
2. S.F.L. -- STRUCTURAL FLOOR LEVEL
3. (R) -- REVERSED DETAIL
4. GLASS LEGEND

EQ1-1 -- 8mmHS+12mm AIR GAP+10mmTP THK. I.G.U.
 EQ1-2 -- 10mm THK. CLEAR TEMPERED GLASS
 EQ1-4 -- 10mm THK. CLEAR TEMPERED GLASS
 EQ1-1A -- 8mmHS+12mm AIR GAP+8mmTP THK. I.G.U.

NO.	DATE	REVISION
C	21/12/2021	REVISION SUBJECT TO ARCH.COMMENT
B	18/10/2021	REVISION SUBJECT TO ARCH.COMMENT
A	12/10/2021	REVISION SUBJECT TO ARCH.COMMENT

JOB NO. : J-856

PROJECT :

PROPOSED DEVELOPMENT ABOVE
LIGHT RAIL TIN WING STOP TSWTL
NO.23,AREA 33,TIN SHUI WAI, N.T.

TITLE :

WINDOW SCHEDULE FOR
TOWER 3 ALUM. WINDOW

DATE : 02-Aug-21 SCALE : 1:40

DRAWN BY : Ivon CHECKED BY :

美特鋁質有限公司
MIDI ALUMINIUM FABRICATOR LTD.
Units 6-8, Sunny Industrial Centre, 1/F
610 Che Kwo Ling Road, Kowloon
Tel:23489211-4 Fax:85227272666

DWG NO. : 856-SD-PW-5313 REV. : C

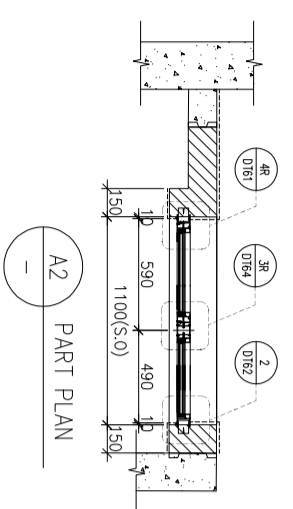
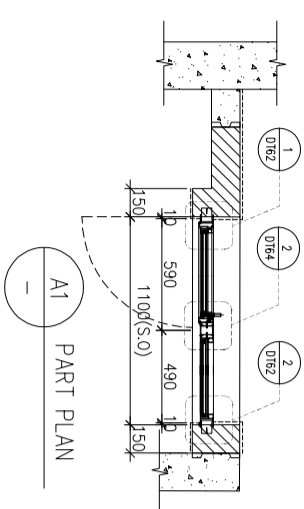
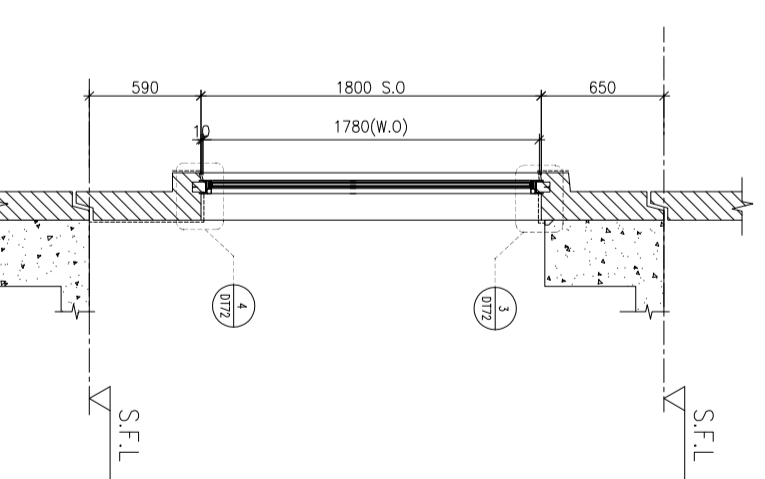
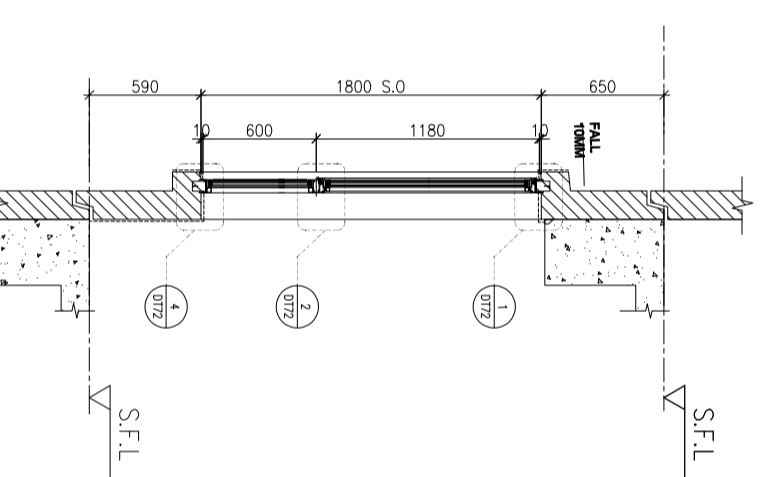
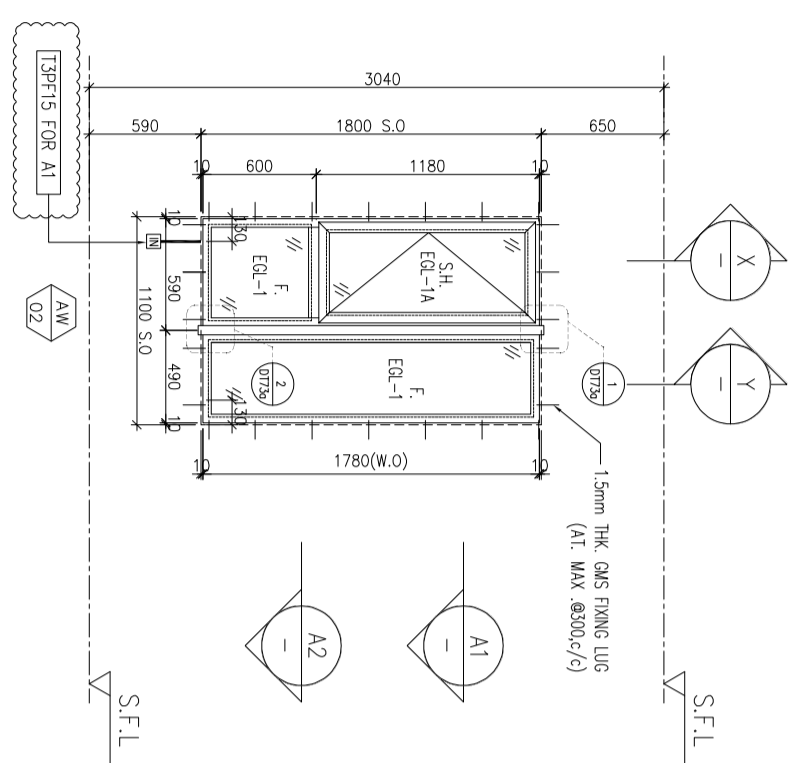

ELEVATION

WINDOW MARK

LOCATION

SECTION

GLAZING

QUANTITY

REMARKS

AW 02

3/F~42/F(4/F,13/F,14/F,24/F,34/F OMITTED) UNIT A1

70mm ALUM. SECTION

EGL-1,EGL-1A

35 Nos.

FAÇADE/TYPE 13PF02 FOR 3/F~42/F)

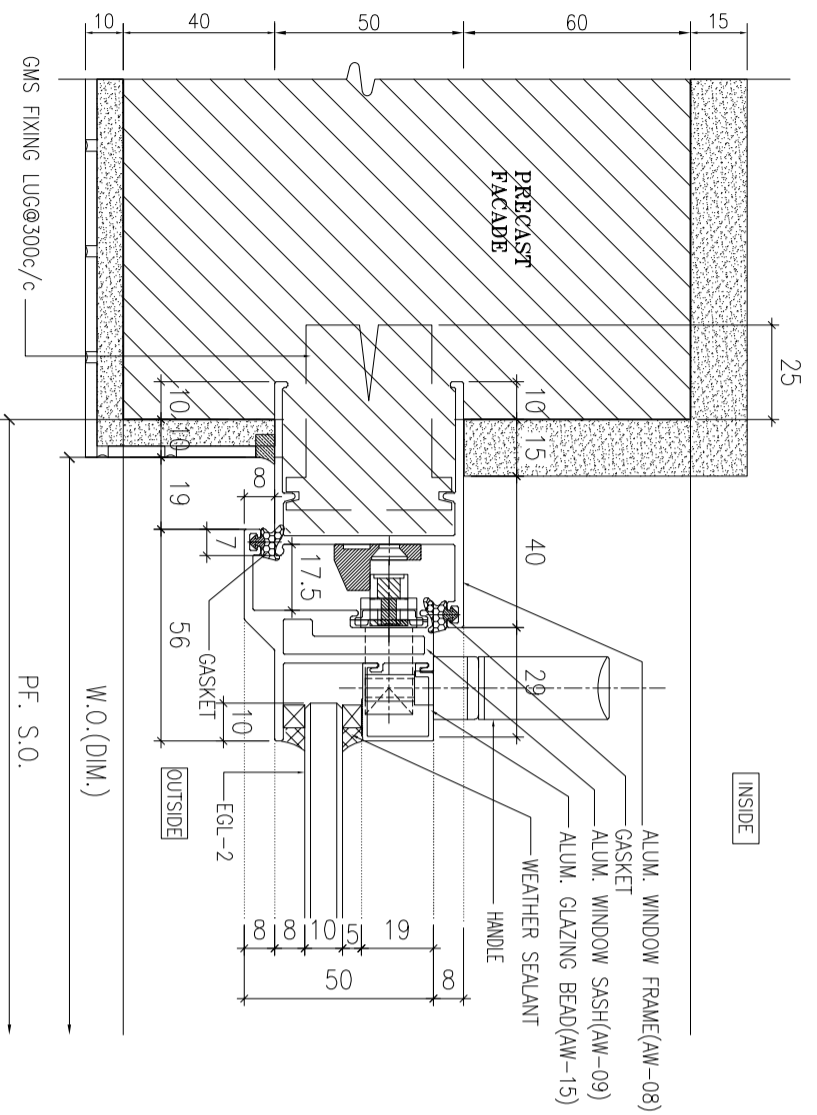

1 HORIZONTAL DETAIL
SCALE 1:2

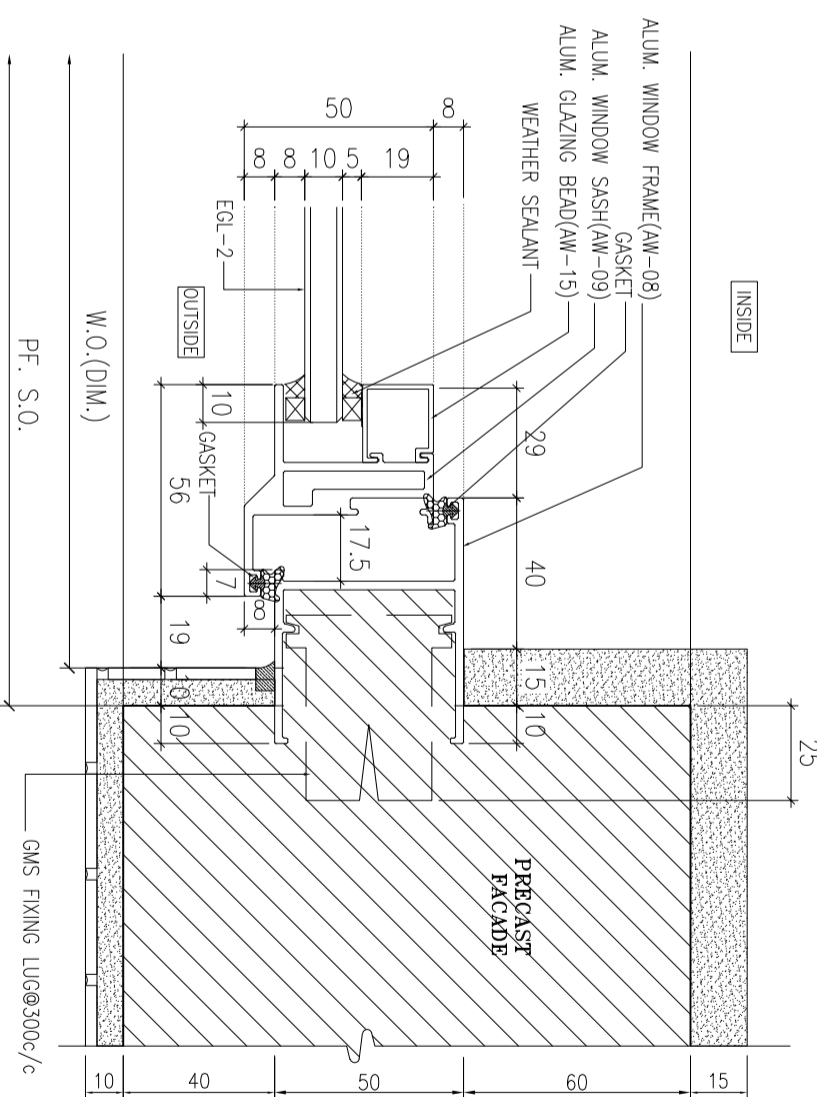

2 HORIZONTAL DETAIL
SCALE 1:2

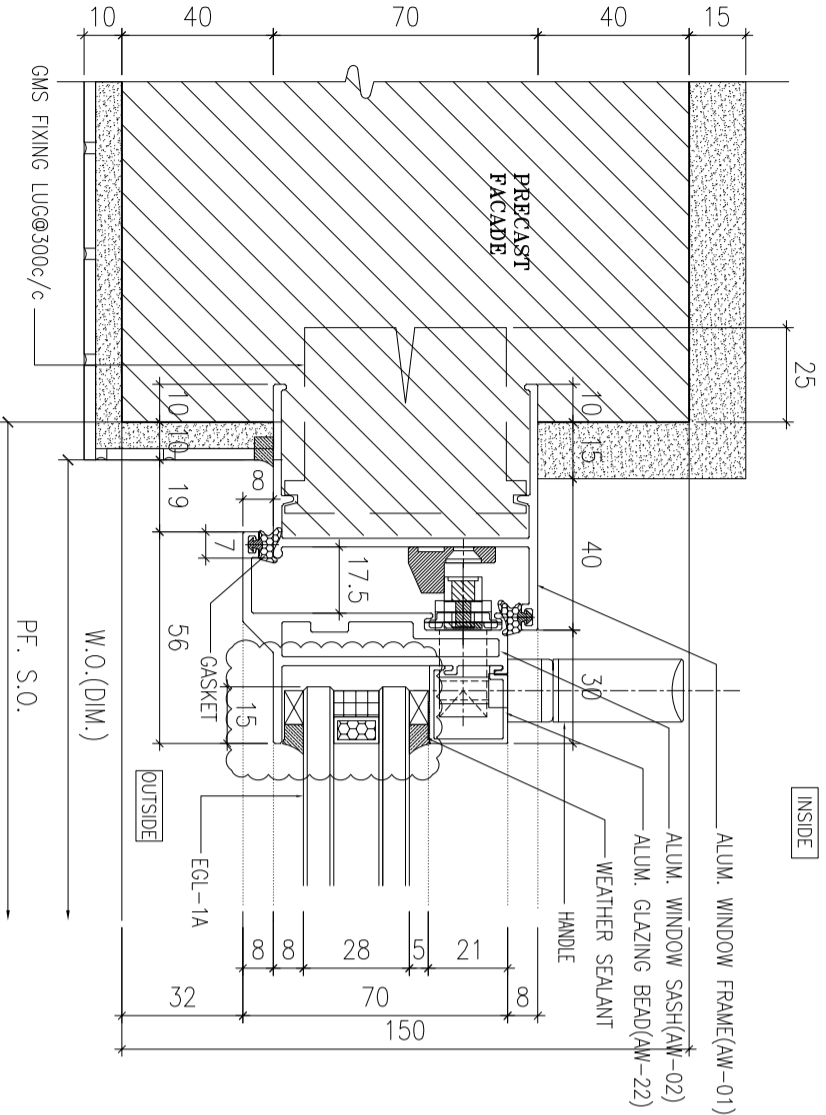

3 HORIZONTAL DETAIL
SCALE 1:2

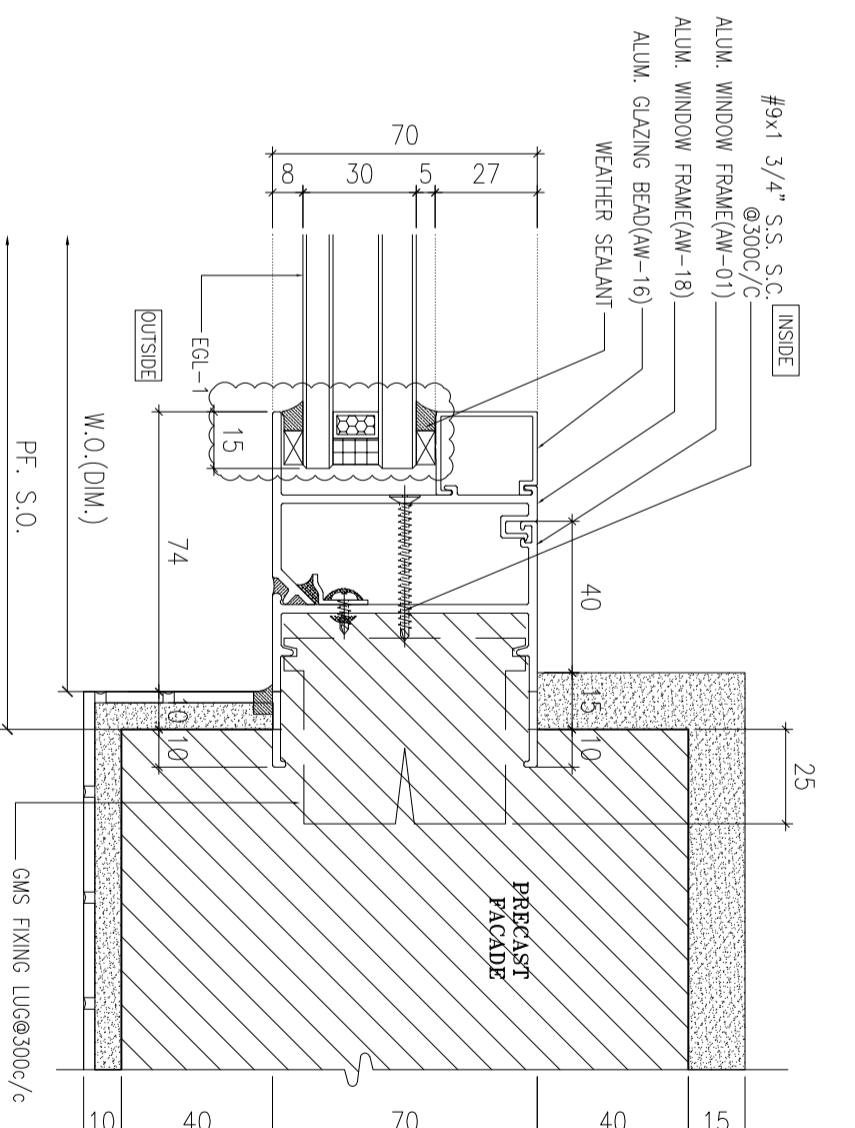

4 HORIZONTAL DETAIL
SCALE 1:2

B.O. REF :

CLIENT :

SUN HUNG KAI
REAL ESTATE AGENCY LTD.
42/F SUN HUNG KAI CENTRE, WANCHAI, HONGKONG

ARCHITECT :

IWK&partners
a r c h i t e c t s

MAIN CONTRACTOR :

怡輝建築有限公司
Yee Fai Building Contractors Ltd.

STRUCTURAL ENGINEER :

ARUP

FAÇADE CONSULTANT:

ALPHA CONSULTING LIMITED
Steel Structure & Façade Specialist

NOTE :

1. ALL DIMENSIONS ARE IN mm.
2. ALL ELEVATIONS ARE VIEWED FROM OUTSIDE.
3. ALL DIMENSIONS TO BE VERIFIED ON SITE BEFORE FABRICATION.

LEGEND :

- X1 DETAIL MARK NO.
- X001 REFER SHEET NO.

1. F.F.L.--FINISHED FLOOR LEVEL
 2. S.F.L.--STRUCTURAL FLOOR LEVEL
 3. (R) --REVERSED DETAIL
 4. GLASS LEGEND
- EGL-1--9mmHS+12mm AIR GAP+10mmTP THK. I.G.U.
EGL-2--10mm THK. CLEAR TEMPERED GLASS
EGL-4--10mm THK. TEMPERED ACID ETCHED GLASS
EGL-1A--8mmHS+12mm AIR GAP+8mmTP THK. I.G.U.

NO.	DATE	REVISION SUBJECT TO ARCH/COMMENT	BY
A	30/10/2021	REVISION SUBJECT TO ARCH/COMMENT	IVGN

JOB NO. : J-856

PROJECT : PROPOSED DEVELOPMENT ABOVE LIGHT RAIL TIN WING STOP TSWTL NO.23,AREA 33,TIN SHUI WAI, N.T.

TITLE : TYPICAL DETAILS FOR ALUM. WINDOW

DATE : 02-Aug-21 SCALE : 1:40

DRAWN BY : IVGN CHECKED BY :

美特鋁質有限公司
MIDI ALUMINIUM FABRICATOR LTD.
Units 6-8, Sunny Industrial Centre, 1/F
610 Che Kwo Ling Road, Kowloon
Tel:23489211-4 Fax:8522727666
DWG NO. : J856-SD-PW-DT61 REV. : B

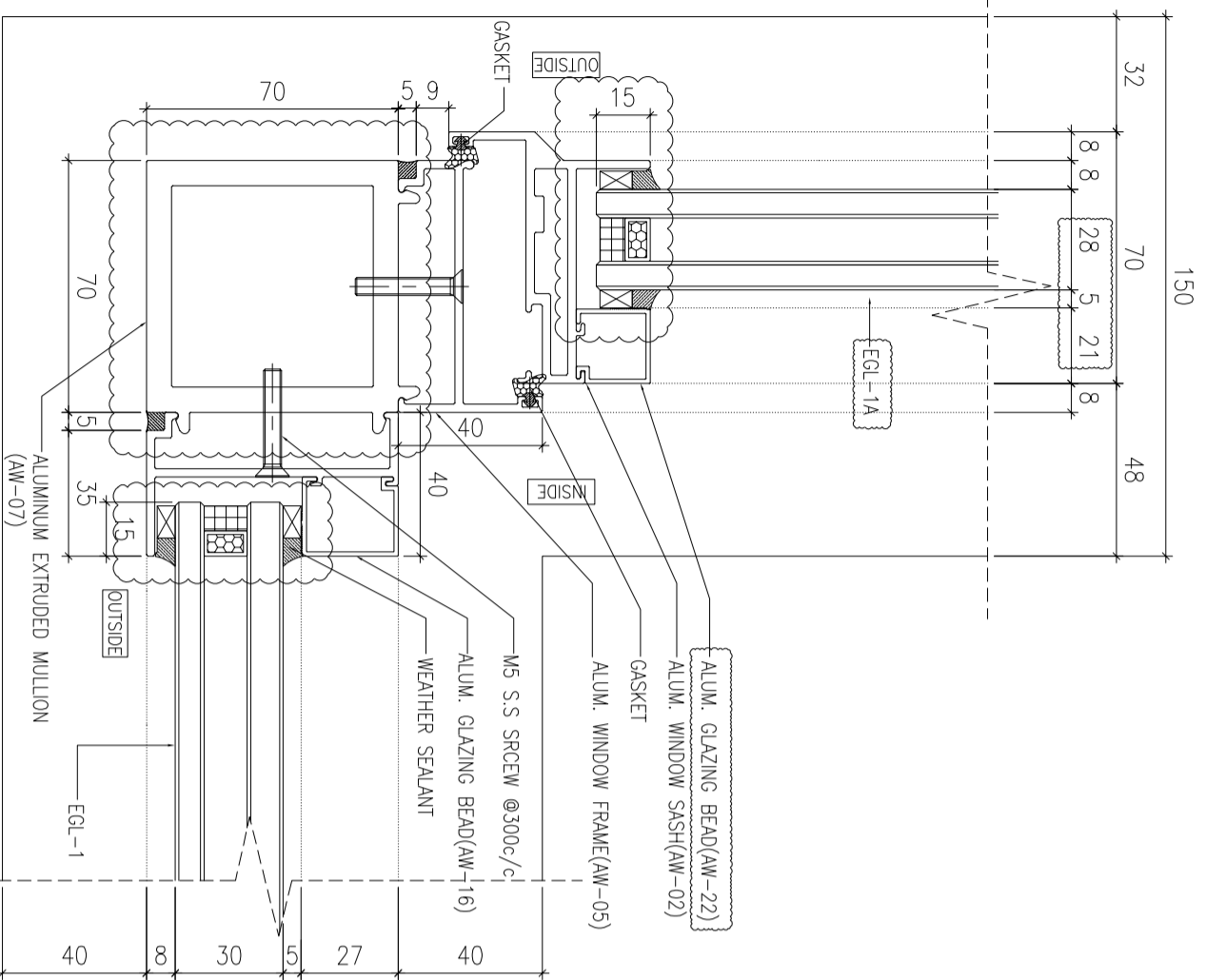

1 HORIZONTAL DETAIL
SCALE 1:2

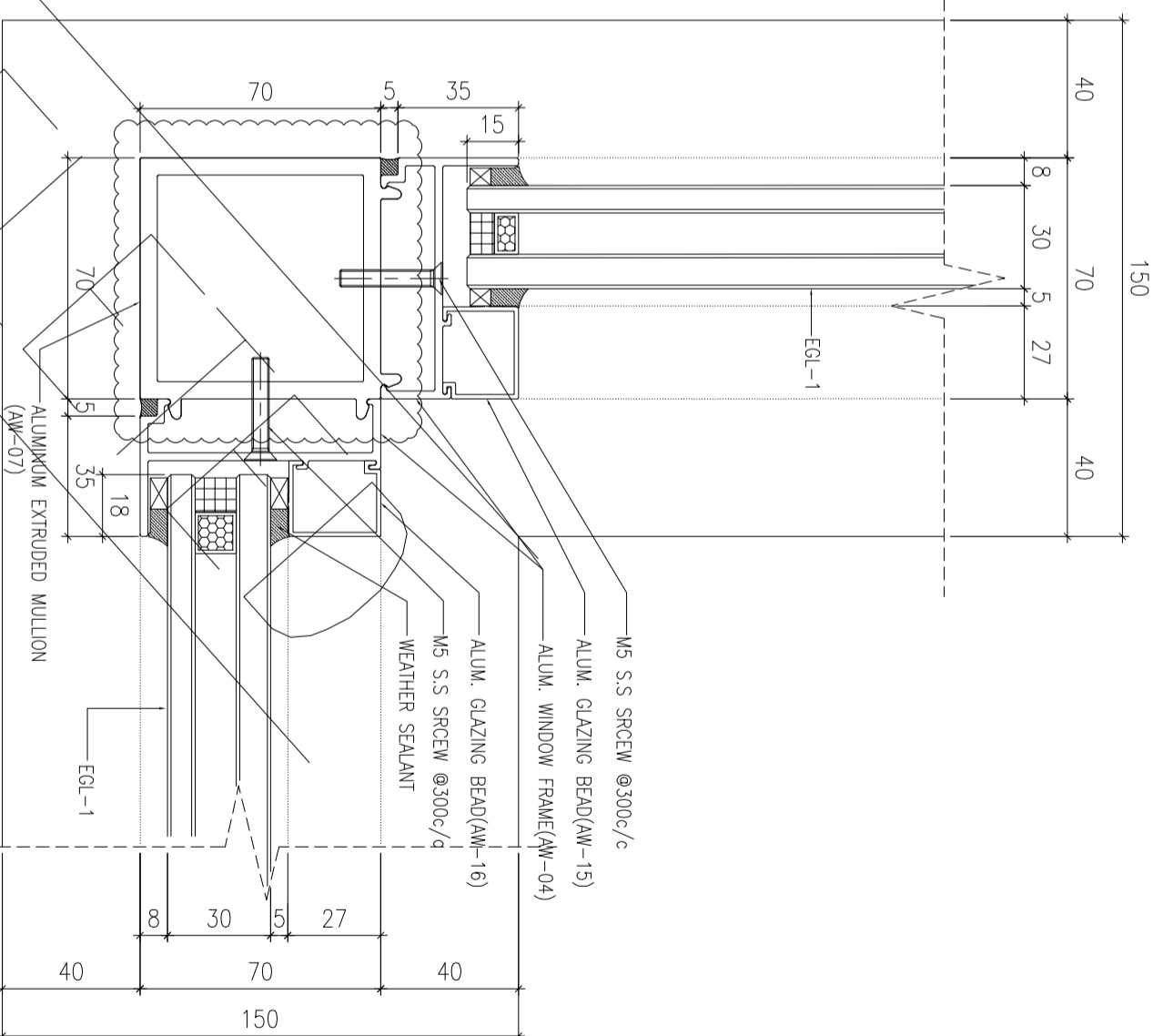

2 HORIZONTAL DETAIL
SCALE 1:2

B.O. REF :

CLIENT :

SUN HUNG KAI
REAL ESTATE AGENCY LTD.
42/F SUN HUNG KAI CENTRE, WANGCHAI, HONGKONG

ARCHITECT :

IWK&partners
a r c h i t e c t s

MAIN CONTRACTOR :

怡輝建築有限公司
Yee Fai Building Contractors Ltd.

STRUCTURAL ENGINEER :

ARUP
Steel Structure & Facade Specialist

FAÇADE CONSULTANT:

ALPHA CONSULTING LIMITED
Steel Structure & Facade Specialist

NOTE :

1. ALL DIMENSIONS ARE IN mm.
2. ALL ELEVATIONS ARE VIEWED FROM OUTSIDE.
3. ALL DIMENSIONS TO BE VERIFIED ON SITE BEFORE FABRICATION.

LEGEND :

X1 - DETAIL MARK NO.
X001 - REFER SHEET NO.

1. F.F.L.--FINISHED FLOOR LEVEL
2. S.F.L.--STRUCTURAL FLOOR LEVEL
3. (R) --REVERSED DETAIL

4. GLASS LEGEND

- EGL-1--9mmHS+12mm AIR GAP+10mmTP THK. I.G.U.
EGL-2--10mm THK. CLEAR TEMPERED GLASS
EGL-4--10mm THK. TEMPERED ACID ETCHED GLASS
EGL-1A--8mmHS+12mm AIR GAP+8mmTP THK. I.G.U.

NO.	DATE	REVISION	BY
C	02/11/2021	REVISION SUBJECT TO ARCH.COMMENT	ivan
B	30/09/2021	REVISION SUBJECT TO ARCH.COMMENT	ivan
A	30/09/2021	REVISION SUBJECT TO ARCH.COMMENT	ivan

JOB NO. : J-856

PROJECT :

PROPOSED DEVELOPMENT ABOVE
LIGHT RAIL TIN WING STOP TSWTL
NO.23,AREA 33,TIN SHUI WAI, N.T.

TITLE :

TYPICAL DETAILS FOR
ALUM. WINDOW

DATE : 02-Aug-21 SCALE : 1:40

DRAWN BY : ivan CHECKED BY :

MIDI ALUMINIUM FABRICATOR LTD.
Units 6-8, Sunny Industrial Centre, 1/F
610 Che Kwo Ling Road, Kowloon
Tel:23489211-4 Fax:8522727666

DWG NO. : JB56-SD-PW-DT63 REV. : C

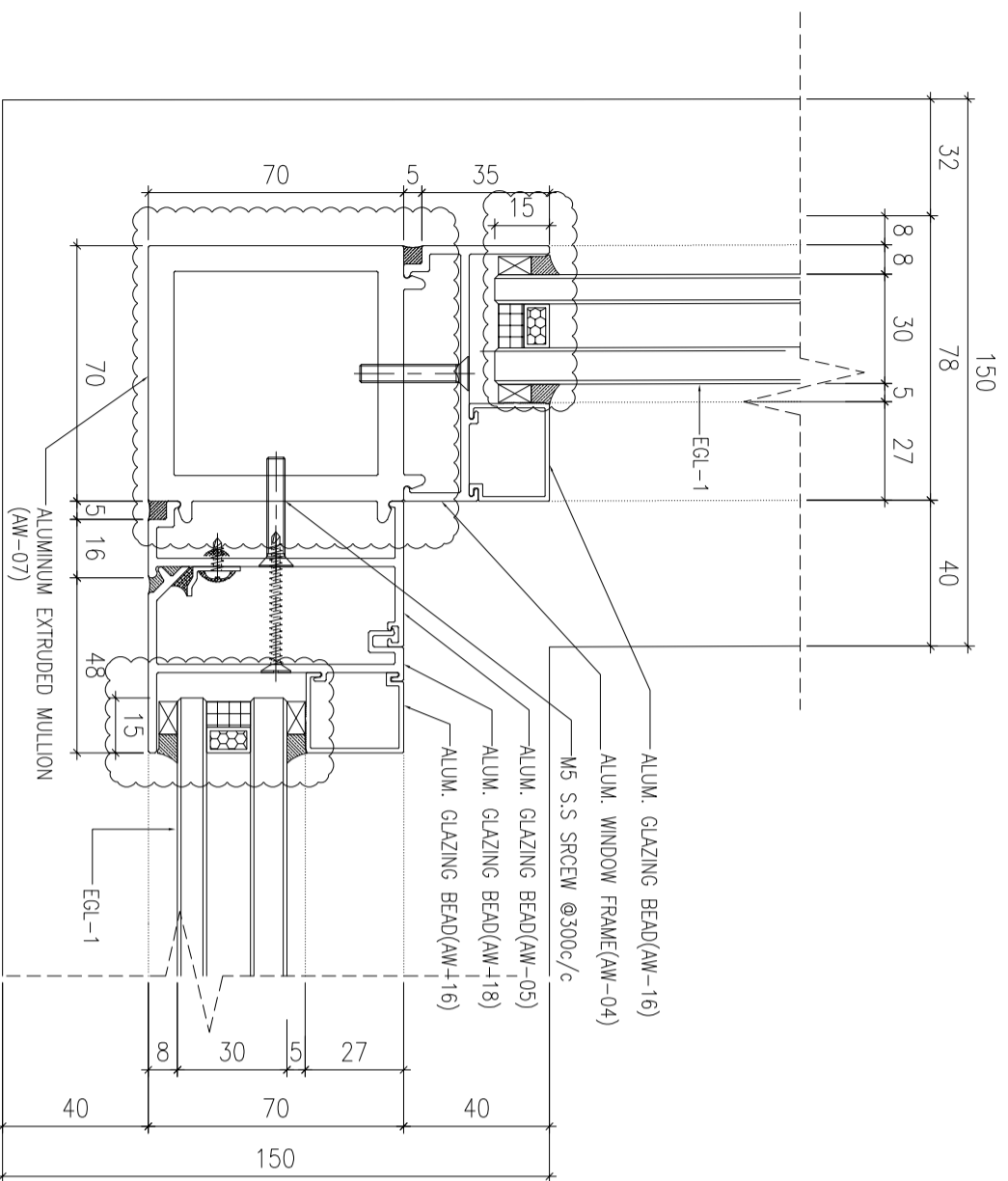

1 HORIZONTAL DETAIL
SCALE 1:2

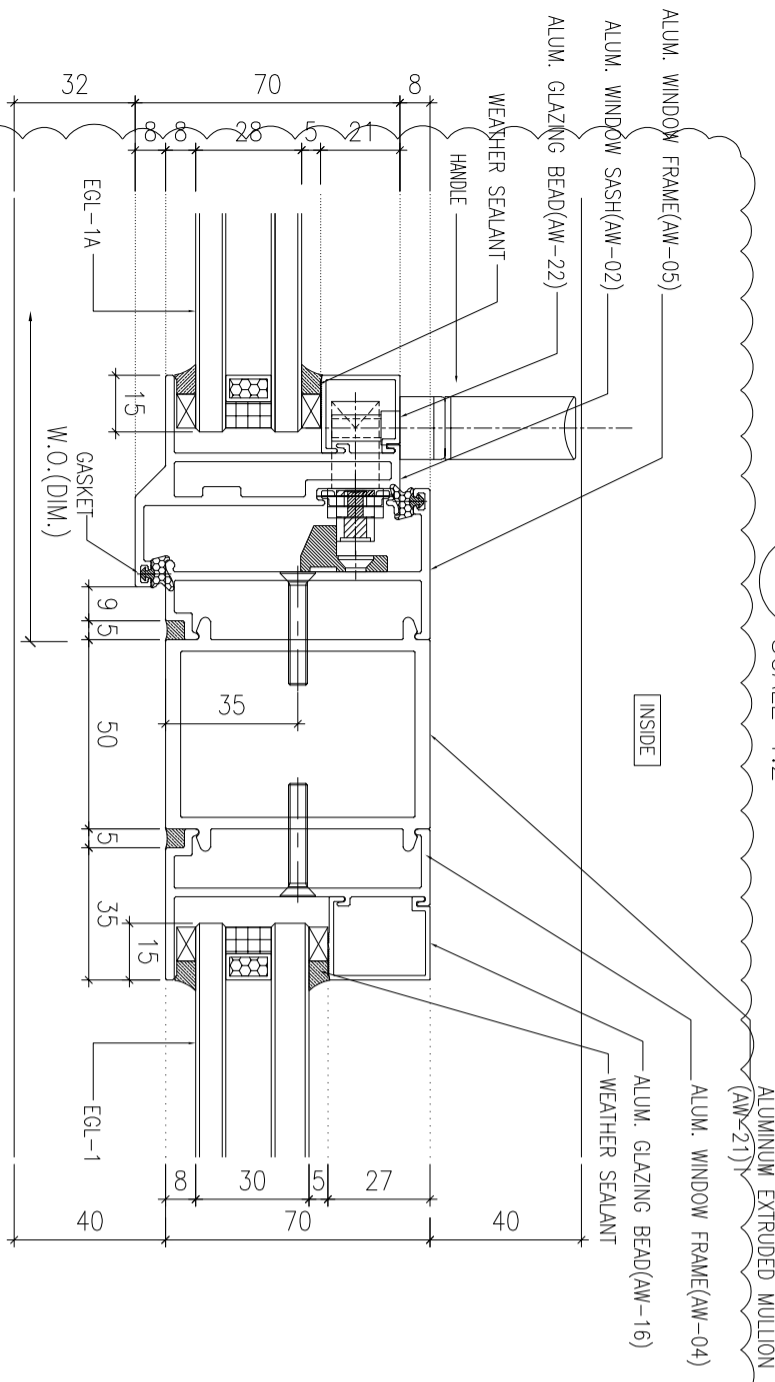

2 HORIZONTAL DETAIL
SCALE 1:2

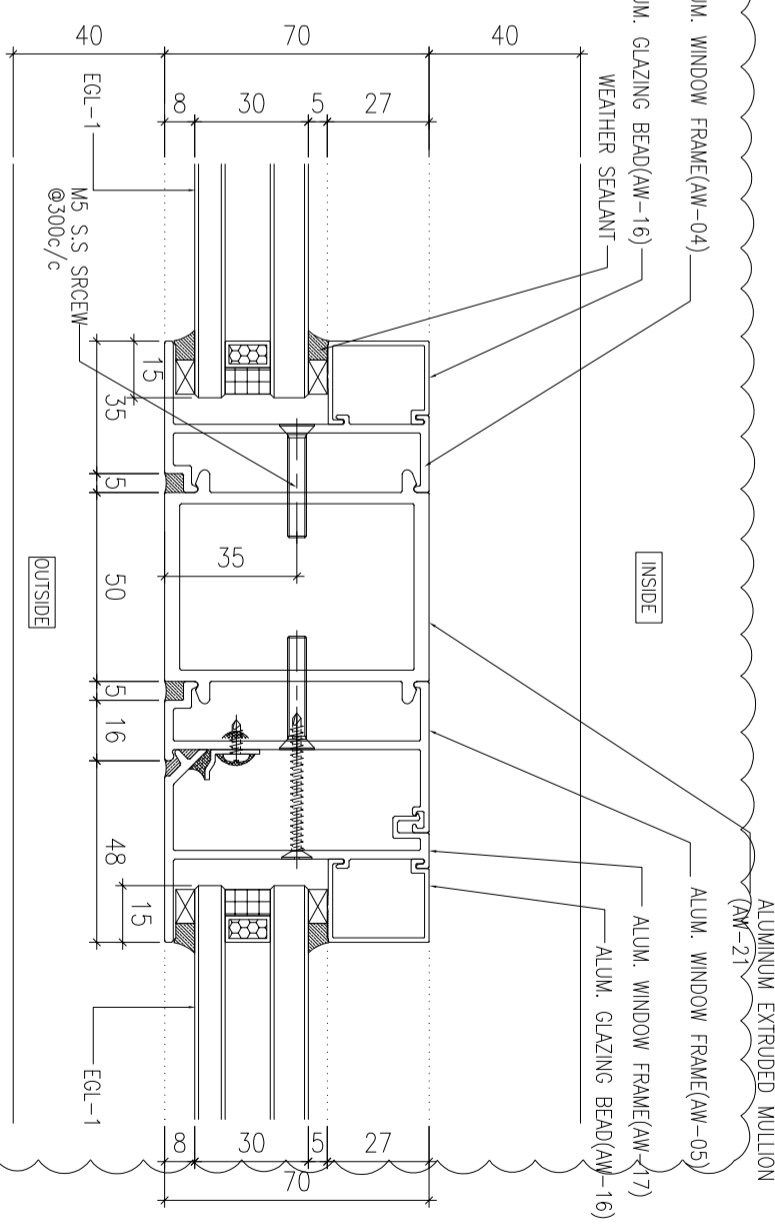

3 HORIZONTAL DETAIL
SCALE 1:2

B.O. REF :

CLIENT :

SUN HUNG KAI
REAL ESTATE AGENCY LTD.
42/F SUN HUNG KAI CENTRE, WANCHAI, HONGKONG

ARCHITECT :

IWK&partners
a r c h i t e c t s

MAIN CONTRACTOR :

怡輝建築有限公司
Yee Fai Building Contractors Ltd.

STRUCTURAL ENGINEER :

ARUP

FAÇADE CONSULTANT :

ALPHA CONSULTING LIMITED
Steel Structure & Façade Specialist

NOTE :

1. ALL DIMENSIONS ARE IN mm.
2. ALL ELEVATIONS ARE VIEWED FROM OUTSIDE.
3. ALL DIMENSIONS TO BE VERIFIED ON SITE BEFORE FABRICATION.

LEGEND :

- X1 --- DETAIL MARK NO.
- X001 --- REFER SHEET NO.

1. F.F.L.--FINISHED FLOOR LEVEL
2. S.F.L.--STRUCTURAL FLOOR LEVEL
3. (R) --REVERSED DETAIL

4. GLASS LEGEND

- EGL-1--9mmHS+12mm AIR GAP+10mmTP THK. I.G.U.
- EGL-2--10mm THK. CLEAR TEMPERED GLASS
- EGL-4--10mm THK. TEMPERED ACID ETCHED GLASS
- EGL-1A--9mmHS+12mm AIR GAP+9mmTP THK. I.G.U.

NO.	DATE	REVISION
D	02/11/2021	REVISION SUBJECT TO ARCH.COMMENT I/IV
C	30/10/2021	REVISION SUBJECT TO ARCH.COMMENT I/IV
B	18/10/2021	REVISION SUBJECT TO ARCH.COMMENT I/IV
A	30/09/2021	REVISION SUBJECT TO ARCH.COMMENT I/IV

JOB NO. : J-856

PROJECT :
PROPOSED DEVELOPMENT ABOVE
LIGHT RAIL TIN WING STOP TSWTL
NO.23,AREA 33,TIN SHUI WAI, N.T.

TITLE :
TYPICAL DETAILS FOR
ALUM. WINDOW

DATE : 02-Aug-21 SCALE : 1:40

DRAWN BY : I/IVN CHECKED BY :

美特鋁質有限公司
MIDI ALUMINIUM FABRICATOR LTD.
Units 6-8, Sunny Industrial Centre, 1/F
610 Che Kwo Ling Road, Kowloon
Tel:23489211-4 Fax:(852)27270666
DWG NO. : J856-SD-PW-DT64 REV. : D

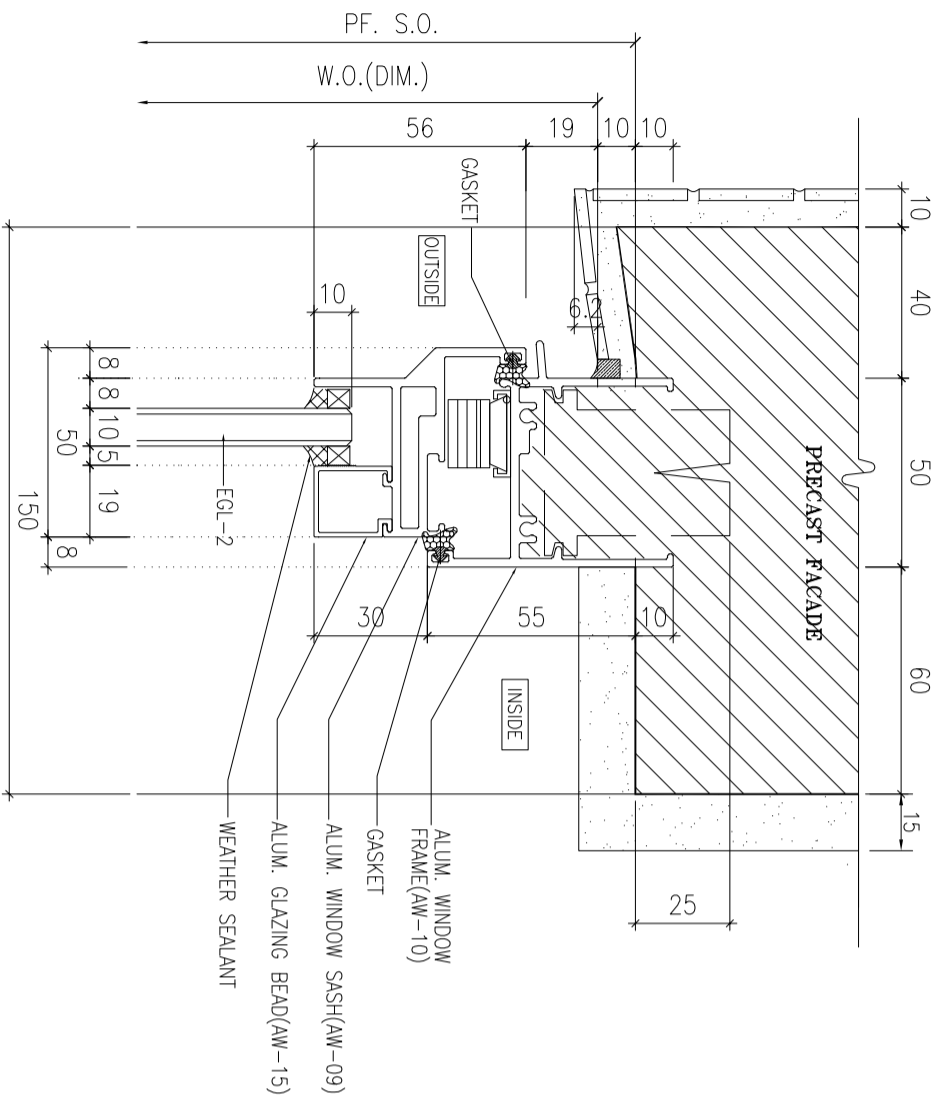

1 HORIZONTAL DETAIL
SCALE 1:2
150

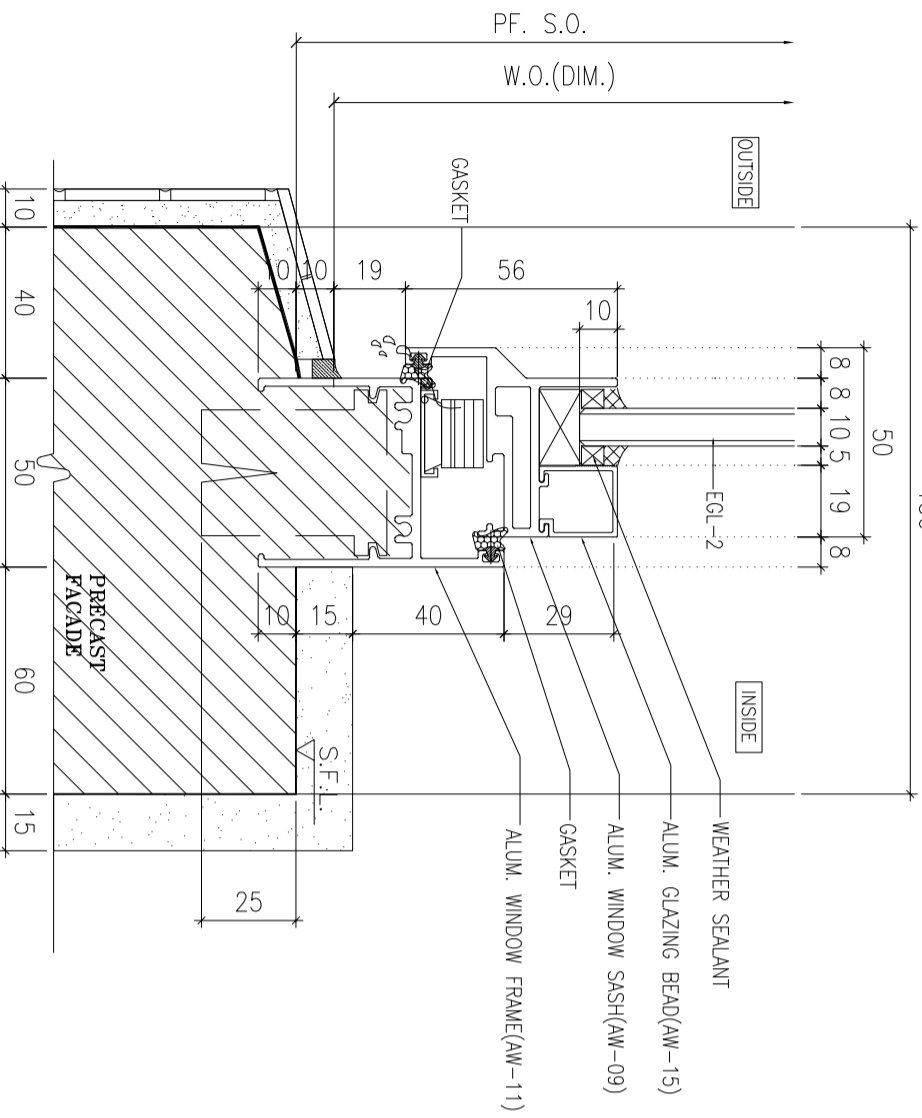

2 HORIZONTAL DETAIL
SCALE 1:2

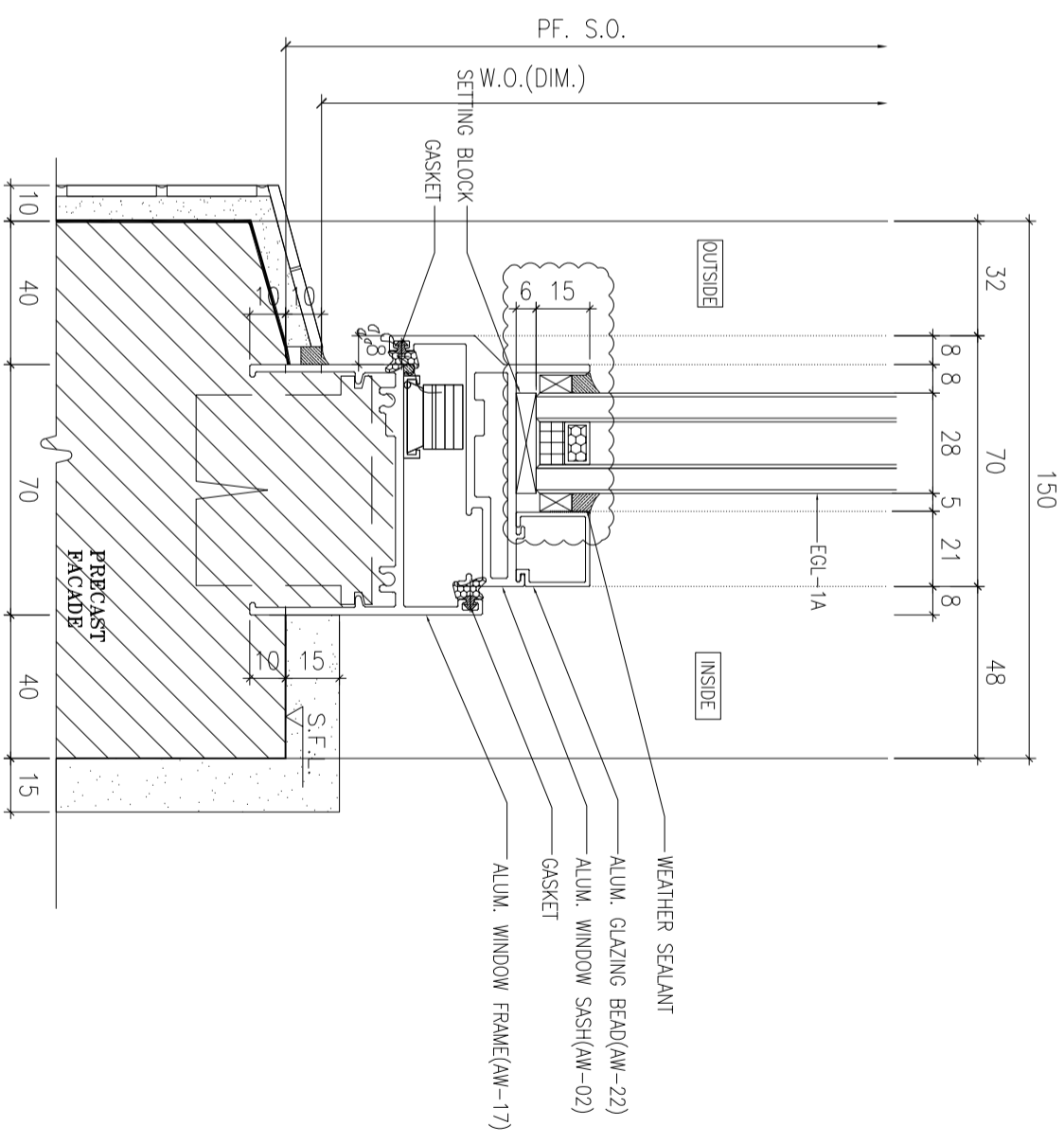

3 HORIZONTAL DETAIL
SCALE 1:2

B.O. REF :

CLIENT :
SUN HUNG KAI
REAL ESTATE AGENCY LTD.
42/F SUN HUNG KAI CENTRE, WANGCHAI, HONGKONG

ARCHITECT :
IWK&partners
a r c h i t e c t s

MAIN CONTRACTOR :
怡輝建築有限公司
Yee Fai Building Contractors Ltd.

STRUCTURAL ENGINEER :
ARUP

FAÇADE CONSULTANT:
ALPHA CONSULTING LIMITED
Steel Structure & Façade Specialist

NOTE :
1. ALL DIMENSIONS ARE IN mm.
2. ALL ELEVATIONS ARE VIEWED FROM OUTSIDE.
3. ALL DIMENSIONS TO BE VERIFIED ON SITE BEFORE FABRICATION.

LEGEND :
X1 --- DETAIL MARK NO.
X001 --- REFER SHEET NO.

1. F.F.L.--FINISHED FLOOR LEVEL
2. S.F.L.--STRUCTURAL FLOOR LEVEL
3. (R) ---REVERSED DETAIL
4. GLASS LEGEND
EGL-1--8mmHS+12mm AIR GAP+10mmTP THK. I.G.U.
EGL-2--10mm THK. CLEAR TEMPERED GLASS
EGL-4--10mm THK. TEMPERED ACID ETCHED GLASS
EGL-1A--8mmHS+12mm AIR GAP+8mmTP THK. I.G.U.

NO.	DATE	REVISION SUBJECT TO ARCH/COMMENT	BY
A	30/10/2021	REVISION SUBJECT TO ARCH/COMMENT	WYH
B	02/11/2021	REVISION SUBJECT TO ARCH/COMMENT	WYH

JOB NO. : J-856
PROJECT : PROPOSED DEVELOPMENT ABOVE LIGHT RAIL TIN WING STOP TSWTL NO.23,AREA 33,TIN SHUI WAI, N.T.
TITLE : TYPICAL DETAILS FOR ALUM. WINDOW

DATE : 02-Aug-21 SCALE : 1:40
DRAWN BY : IYVH CHECKED BY :

美特鋁質有限公司
MIDI ALUMINIUM FABRICATOR LTD.
Units 6-8, Sunny Industrial Centre, 1/F
610 Che Kwo Ling Road, Kowloon
Tel:23489211-4 Fax:(852)27272666
DWG NO. : JB56-SD-PW-DT71 REV. : B

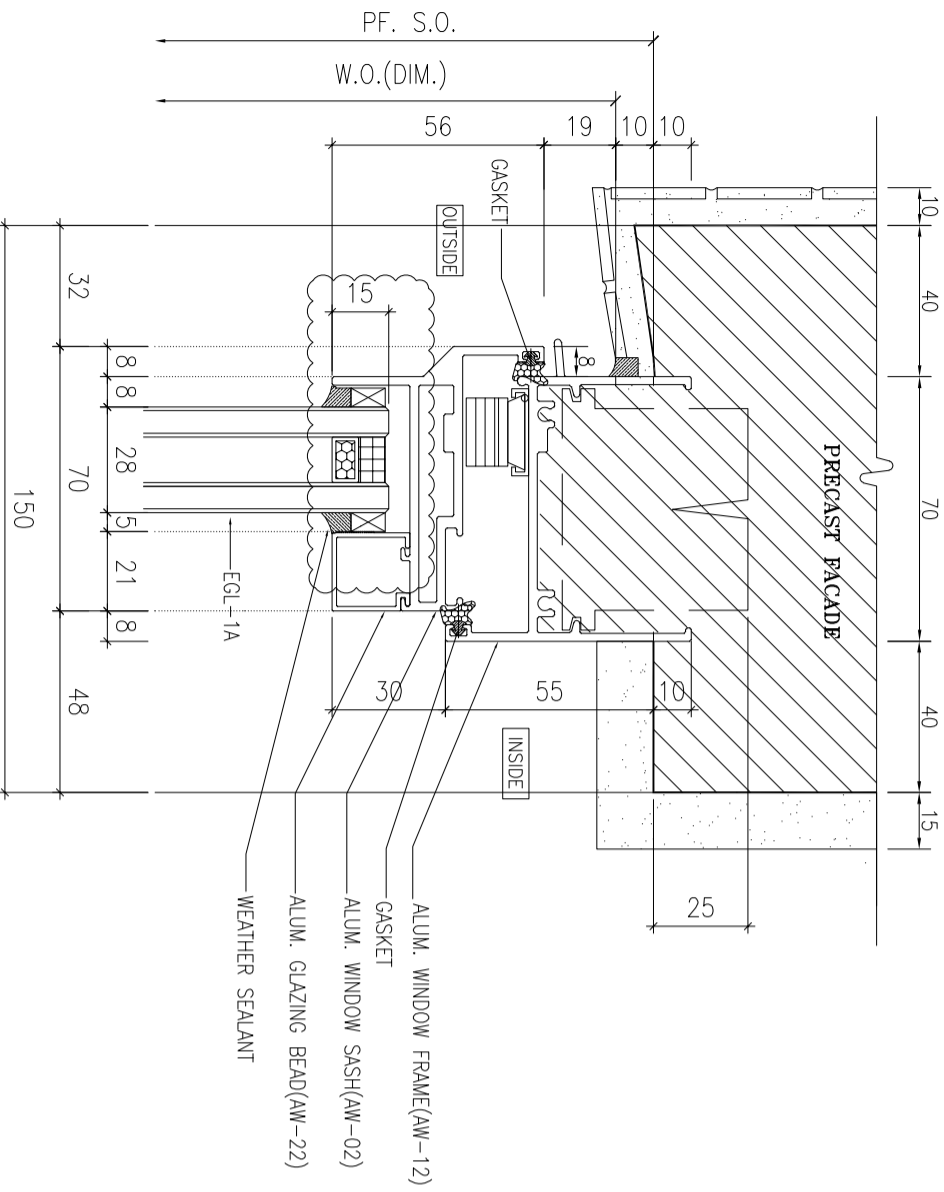

1 HORIZONTAL DETAIL
SCALE 1:2

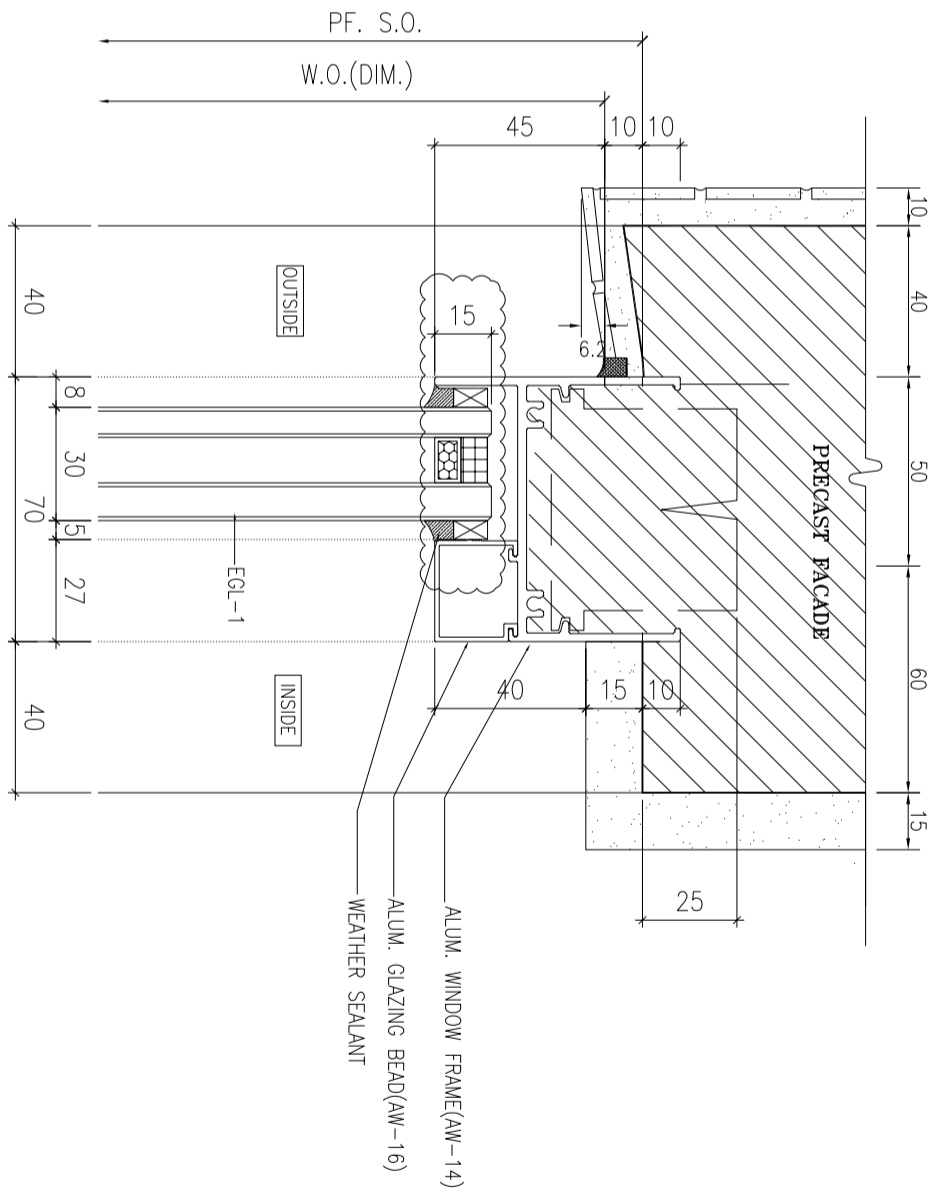

3 HORIZONTAL DETAIL
SCALE 1:2

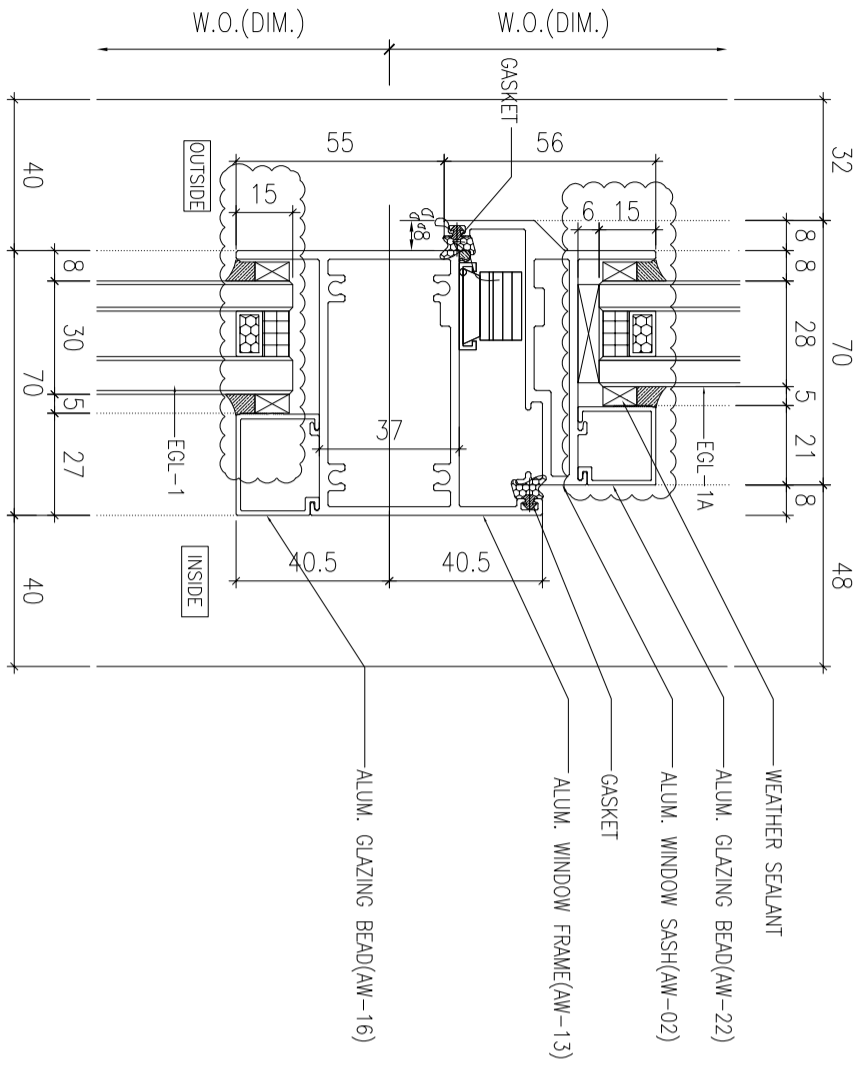

2 HORIZONTAL DETAIL
SCALE 1:2

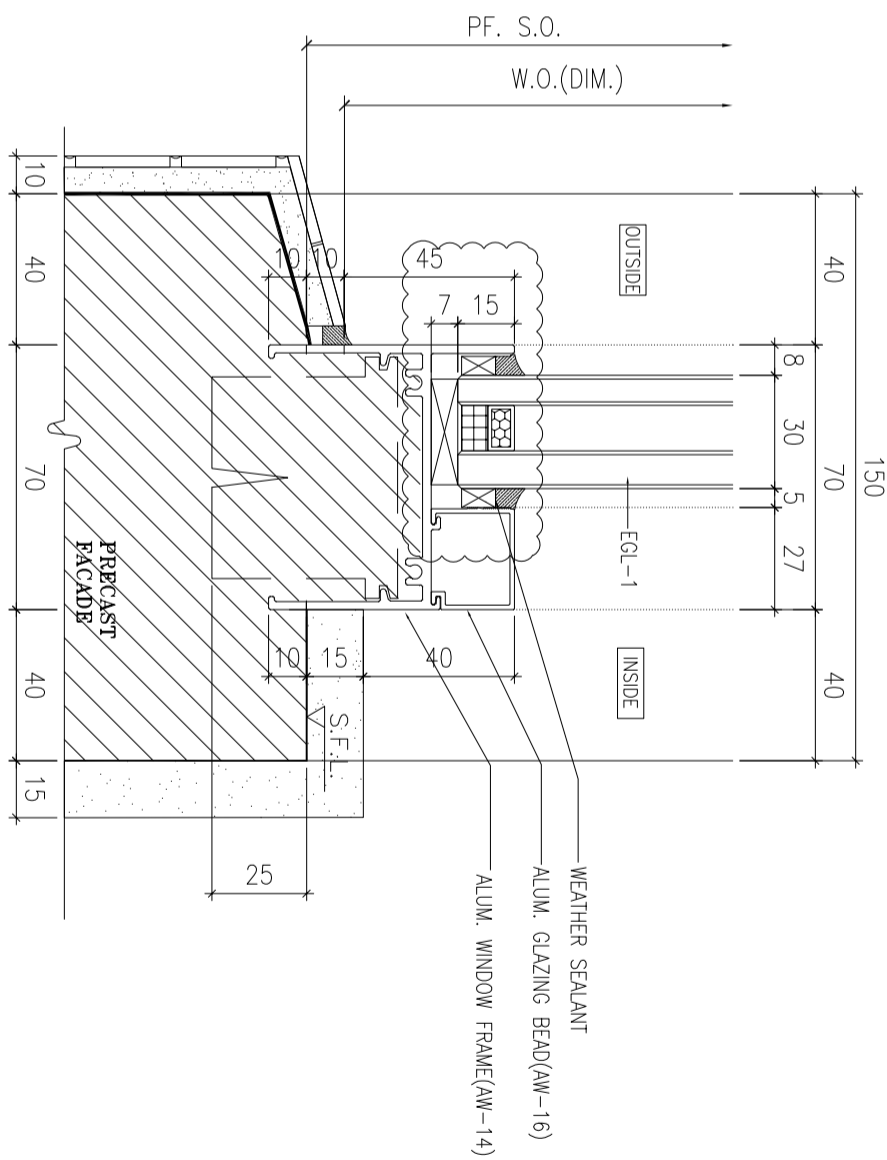

4 HORIZONTAL DETAIL
SCALE 1:2

B.O. REF :

CLIENT :
SUN HUNG KAI
REAL ESTATE AGENCY LTD.
42/F SUN HUNG KAI CENTRE, WANGCHAI, HONGKONG

ARCHITECT :
IWK&partners
a r c h i t e c t s

MAIN CONTRACTOR :
怡輝建築有限公司
Yee Fai Building Contractors Ltd.

STRUCTURAL ENGINEER :
ARUP

FAÇADE CONSULTANT:
ALPHA CONSULTING LIMITED
Steel Structure & Façade Specialist

NOTE :
1. ALL DIMENSIONS ARE IN mm.
2. ALL ELEVATIONS ARE VIEWED FROM OUTSIDE.
3. ALL DIMENSIONS TO BE VERIFIED ON SITE BEFORE FABRICATION.
LEGEND :

- X1 DETAIL MARK NO.
- X001 REFER SHEET NO.
- 1. F.F.L.--FINISHED FLOOR LEVEL
- 2. S.F.L.--STRUCTURAL FLOOR LEVEL
- 3. (R) --REVERSED DETAIL
- 4. GLASS LEGEND
- EGL-1--8mmHS+12mm AIR GAP+10mmTP THK. I.G.U.
- EGL-2--10mm THK. CLEAR TEMPERED GLASS
- EGL-4--10mm THK. TEMPERED ACID ETCHED GLASS
- EGL-1A--8mmHS+12mm AIR GAP+8mmTP THK. I.G.U.

NO.	DATE	REVISION SUBJECT TO ARCH/COMMENT	BY
A	30/10/2021	REVISION SUBJECT TO ARCH/COMMENT	YH
B	02/11/2021	REVISION SUBJECT TO ARCH/COMMENT	YH

JOB NO. : J-856
PROJECT : PROPOSED DEVELOPMENT ABOVE LIGHT RAIL TIN WING STOP TSWTL NO.23,AREA 33,TIN SHUI WAI, N.T.
TITLE : TYPICAL DETAILS FOR ALUM. WINDOW

DATE : 02-Aug-21 SCALE : 1:40
DRAWN BY : IYon CHECKED BY :

美特鋁質有限公司
MIDI ALUMINIUM FABRICATOR LTD.
Units 6-8, Sunny Industrial Centre, 1/F
610 Che Kwo Ling Road, Kowloon
Tel:23489211-4 Fax:185217272666
DWG NO. : J856-SD-PW-DT72 REV. : B

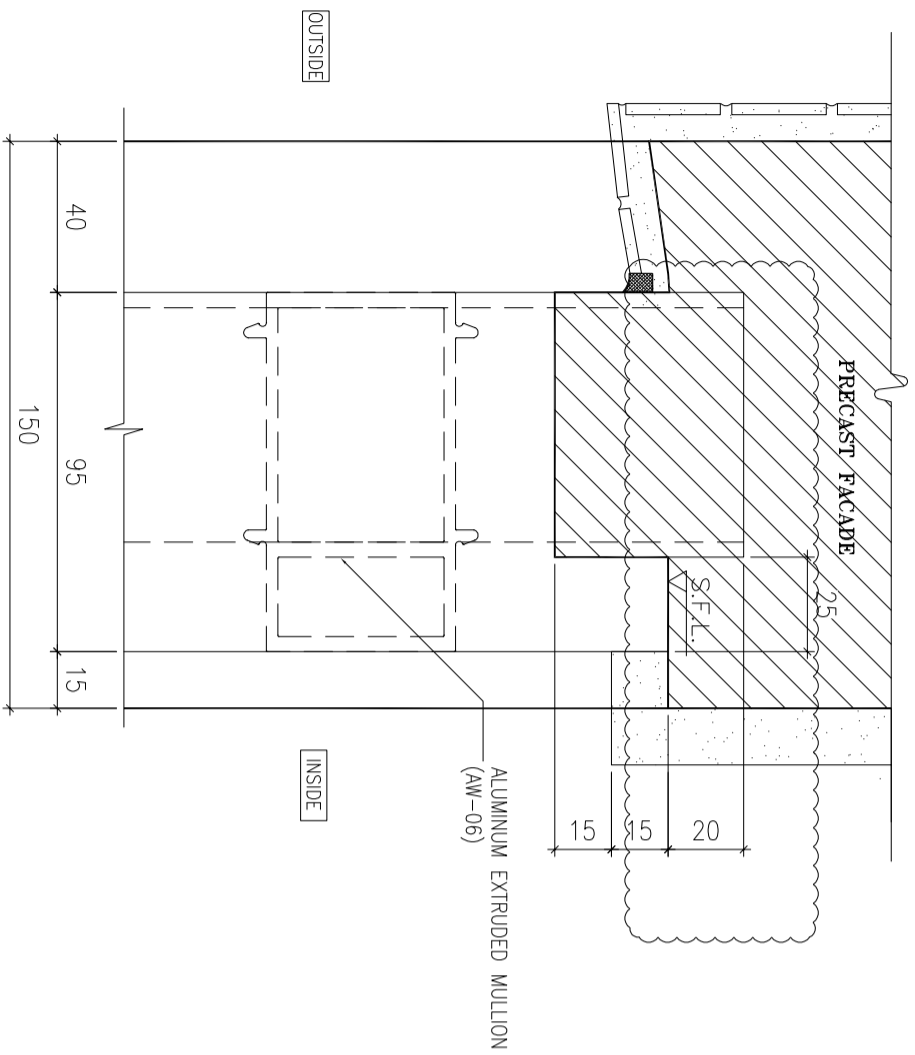

1 HORIZONTAL DETAIL
SCALE 1:2

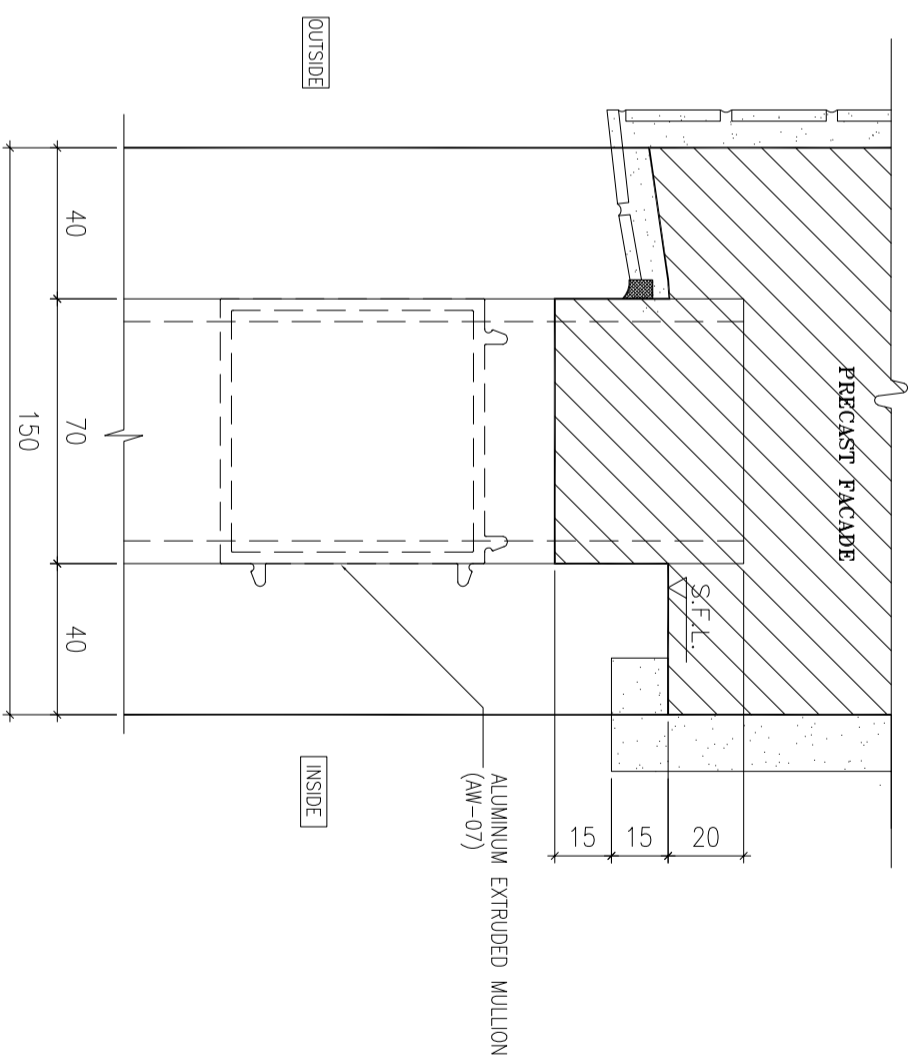

3 HORIZONTAL DETAIL
SCALE 1:2

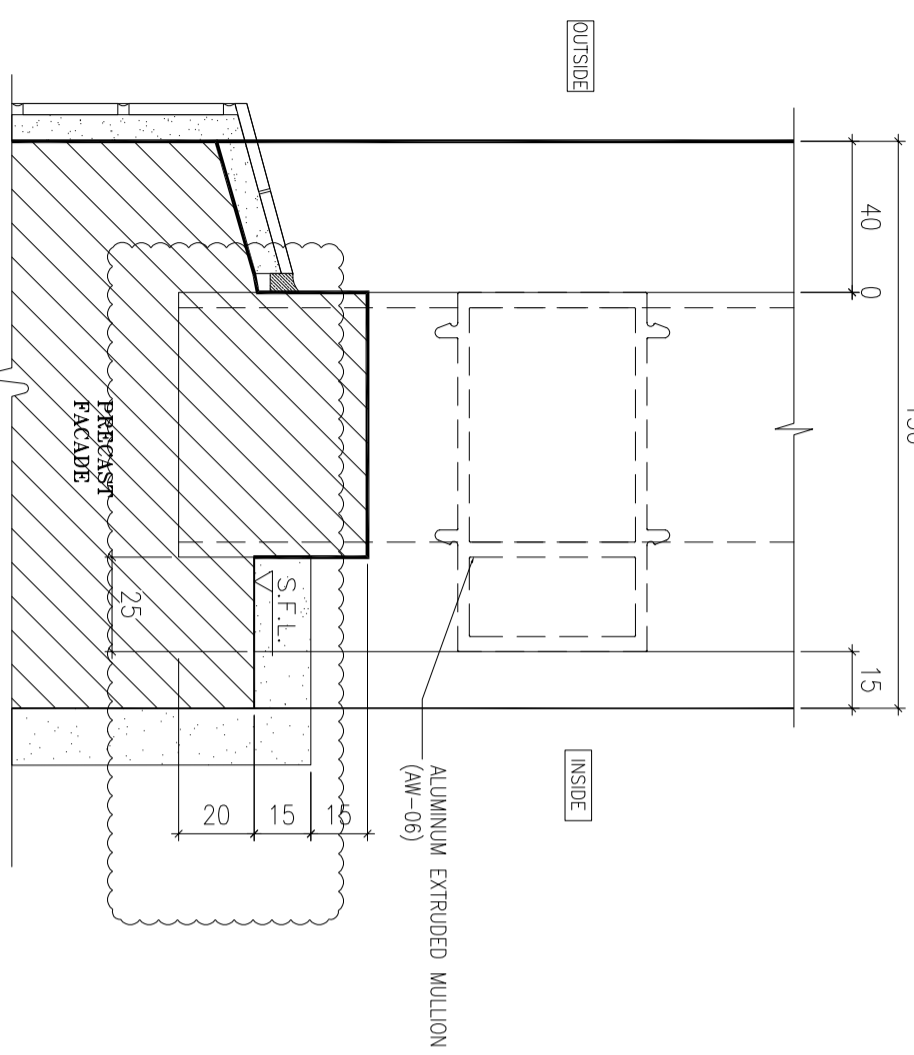

2 HORIZONTAL DETAIL
SCALE 1:2

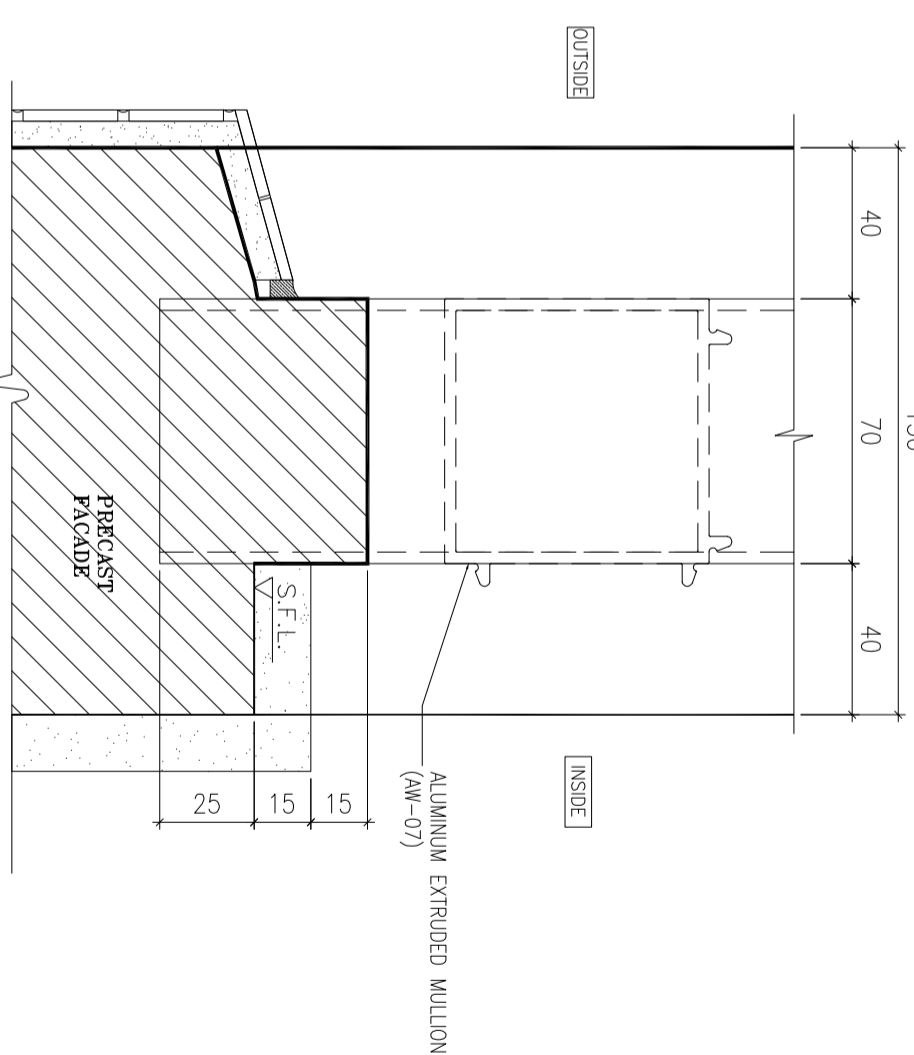

4 HORIZONTAL DETAIL
SCALE 1:2

B.O. REF :

CLIENT :

SUN HUNG KAI
REAL ESTATE AGENCY LTD.
42/F SUN HUNG KAI CENTRE, WANGCHAI, HONGKONG

ARCHITECT :

IWK&partners
a r c h i t e c t s

MAIN CONTRACTOR :

怡輝建築有限公司
Yee Fai Building Contractors Ltd.

STRUCTURAL ENGINEER :

ARUP

FAÇADE CONSULTANT:

ALPHA CONSULTING LIMITED
Steel Structure & Façade Specialist

NOTE :

1. ALL DIMENSIONS ARE IN mm.
2. ALL ELEVATIONS ARE VIEWED FROM OUTSIDE.
3. ALL DIMENSIONS TO BE VERIFIED ON SITE BEFORE FABRICATION.

LEGEND :

X1 DETAIL MARK NO.
X001 REFER SHEET NO.

1. F.F.L.--FINISHED FLOOR LEVEL
2. S.F.L.--STRUCTURAL FLOOR LEVEL
3. (R) --REVERSED DETAIL

4. GLASS LEGEND

- EQ1-1--8mmHS+12mm AIR GAP+10mmTP THK. I.G.U.
- EQ1-2--10mm THK. CLEAR TEMPERED GLASS
- EQ1-4--10mm THK. TEMPERED ACID ETCHED GLASS
- EQ1-1A--8mmHS+12mm AIR GAP+8mmTP THK. I.G.U.

NO.	DATE	REVISION	REVISION SUBJECT TO ARCH/COMMENT	BY
C	02/11/2021	REVISION SUBJECT TO ARCH/COMMENT		ivan
B	30/09/2021	REVISION SUBJECT TO ARCH/COMMENT		ivan
A	30/09/2021	REVISION SUBJECT TO ARCH/COMMENT		ivan

JOB NO. : J-856

PROJECT :

PROPOSED DEVELOPMENT ABOVE
LIGHT RAIL TIN WING STOP TSWTL
NO.23,AREA 33,TIN SHUI WAI, N.T.

TITLE :

TYPICAL DETAILS FOR
ALUM. WINDOW

DATE : 02-Aug-21 SCALE : 1:40

DRAWN BY : ivan CHECKED BY :

美特鋁質有限公司
MIDI ALUMINIUM FABRICATOR LTD.
Units 6-8, Sunny Industrial Centre, 1/F
610 Che Kwo Ling Road, Kowloon
Tel:23489211-4 Fax:8522727666

DWG NO. : J856-SD-PW-DT73 REV. : C

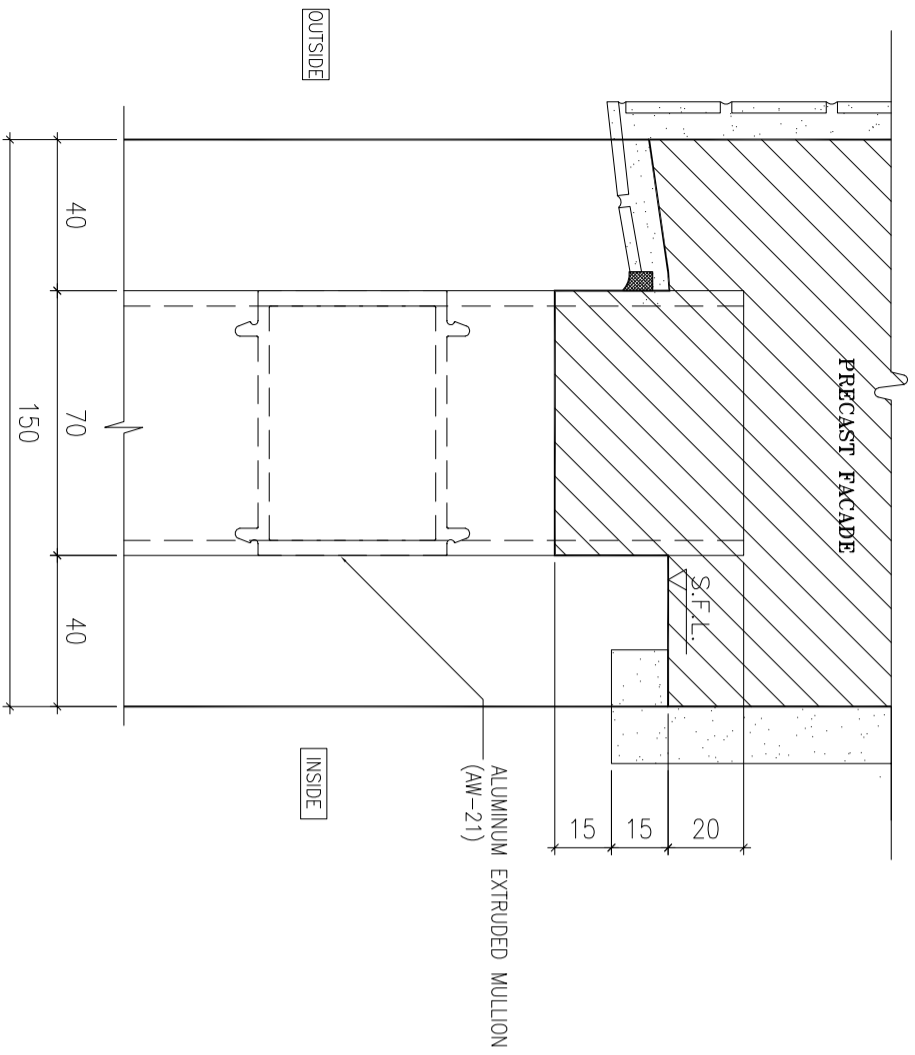

1 HORIZONTAL DETAIL
SCALE 1:2

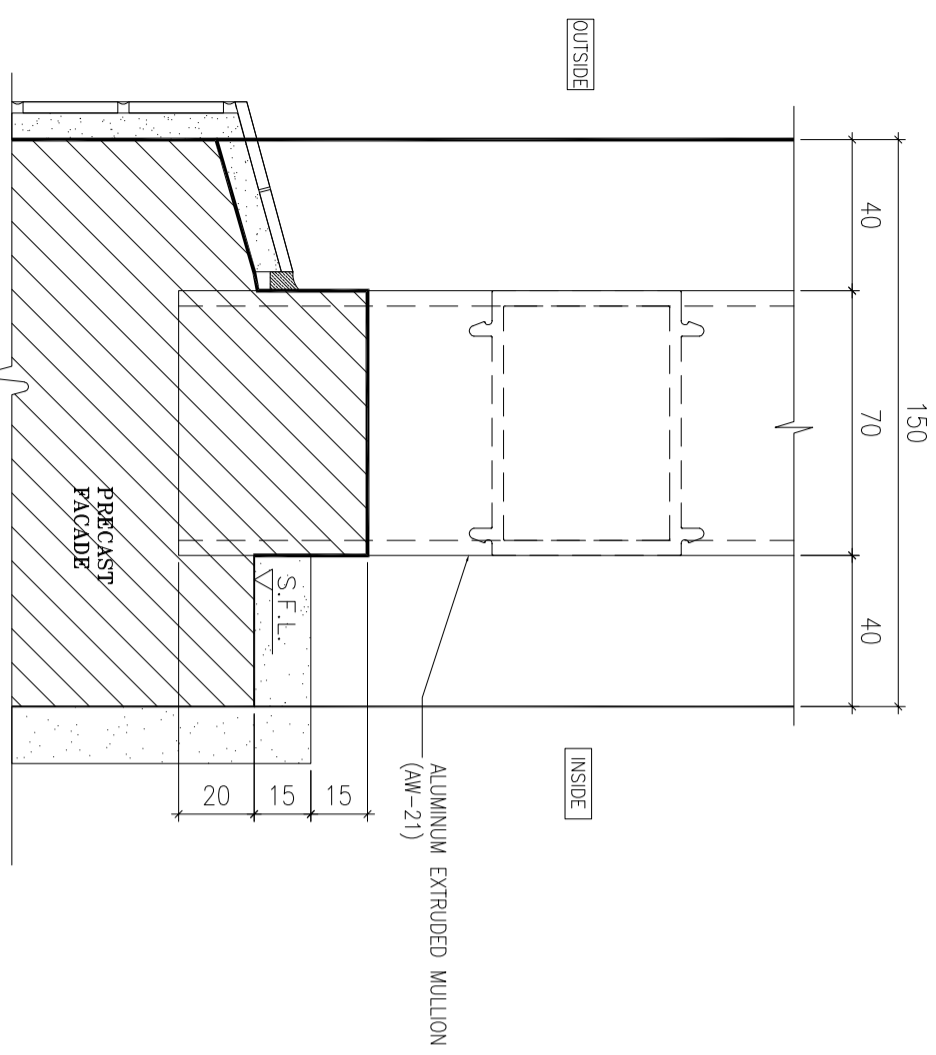

2 HORIZONTAL DETAIL
SCALE 1:2

B.O. REF :

CLIENT :

SUN HUNG KAI
REAL ESTATE AGENCY LTD.
42/F SUN HUNG KAI CENTRE, WANGHAI, HONGKONG

ARCHITECT :

lwk&partners
a r c h i t e c t s

MAIN CONTRACTOR :

怡輝建築有限公司
Yee Fai Building Contractors Ltd.

STRUCTURAL ENGINEER :

ARUP
FAÇADE CONSULTANT:

ALPHA CONSULTING LIMITED
Steel Structure & Façade Specialist

NOTE :

1. ALL DIMENSIONS ARE IN mm.
2. ALL ELEVATIONS ARE VIEWED FROM OUTSIDE.
3. ALL DIMENSIONS TO BE VERIFIED ON SITE BEFORE FABRICATION.

LEGEND :

X1 DETAIL MARK NO.
X001 REFER SHEET NO.

1. F.F.L.--FINISHED FLOOR LEVEL
2. S.F.L.--STRUCTURAL FLOOR LEVEL
3. (R) --REVERSED DETAIL

4. GLASS LEGEND

- EGL-1--8mmHS+12mm AIR GAP+10mmTP THK. I.G.U.
EGL-2--10mm THK. CLEAR TEMPERED GLASS
EGL-4--10mm THK. TEMPERED ACID ETCHED GLASS
EGL-1A--8mmHS+12mm AIR GAP+8mmTP THK. I.G.U.

NO.	DATE	REVISION	BY

JOB NO. : J-856

PROJECT :
PROPOSED DEVELOPMENT ABOVE
LIGHT RAIL TIN WING STOP TSWTL
NO.23,AREA 33,TIN SHUI WAI, N.T.

TITLE :
TYPICAL DETAILS FOR
ALUM. WINDOW

DATE : 02-Aug-21 SCALE : 1:40

DRAWN BY : Ivorn CHECKED BY :

美特鋁質有限公司
MIDI ALUMINIUM FABRICATOR LTD.
Units 6-8, Sunny Industrial Centre, 1/F
610 Che Kwo Ling Road, Kowloon
Tel:23489211-4 Fax:8522727666

DWG NO. : JB56-SD-PW-DT73a REV. : -

B.O. REF :

CLIENT :

SUN HUNG KAI
REAL ESTATE AGENCY LTD.
42/F SUN HUNG KAI CENTRE, WANGCHAI, HONGKONG

ARCHITECT :

lwk&partners
a r c h i t e c t s

MAIN CONTRACTOR :

怡輝建築有限公司
Yee Fai Building Contractors Ltd.

STRUCTURAL ENGINEER :

ARUP

FAÇADE CONSULTANT:

ALPHA CONSULTING LIMITED
Steel Structure & Façade Specialist

NOTE :

1. ALL DIMENSIONS ARE IN mm.
2. ALL ELEVATIONS ARE VIEWED FROM OUTSIDE.
3. ALL DIMENSIONS TO BE VERIFIED ON SITE BEFORE FABRICATION.

LEGEND :

X1 --- DETAIL MARK NO.
X001 --- REFER SHEET NO.

1. F.F.L. --- FINISHED FLOOR LEVEL
2. S.F.L. --- STRUCTURAL FLOOR LEVEL
3. (R) --- REVERSED DETAIL

4. GLASS LEGEND

- EQ1-1 --- 6mmHS+12mm AIR GAP+10mmTP THK. I.G.U.
- EQ1-2 --- 10mm THK. CLEAR TEMPERED GLASS
- EQ1-4 --- 10mm THK. TEMPERED ACID ETCHED GLASS
- EQ1-1A --- 6mmHS+12mm AIR GAP+8mmTP THK. I.G.U.

NO.	DATE	REVISION	BY

JOB NO. : J-856

PROJECT :

PROPOSED DEVELOPMENT ABOVE
LIGHT RAIL TIN WING STOP TSWTL
NO.23,AREA 33,TIN SHUI WAI, N.T.

TITLE :

ALUM. WINDOW SECTION
TYPICAL LOCK & HINGES DETAIL

DATE : 02-Aug-21 SCALE : 1:40

DRAWN BY : Ivorn CHECKED BY :

美特鋁質有限公司
MIDI ALUMINIUM FABRICATOR LTD.
Units 6-8, Sunny Industrial Centre, 1/F
610 Che Kwo Ling Road, Kowloon
Tel:23489211-4 Fax:8522727666

DWG NO. : JB56-SD-PW-DT74 REV. : -

70窗

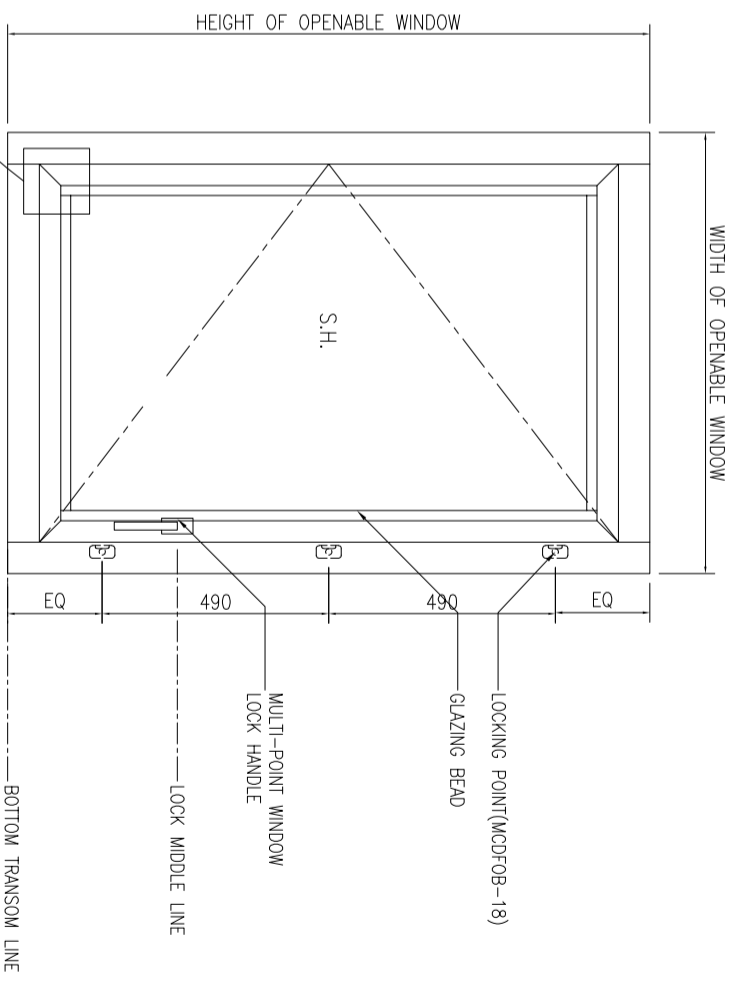
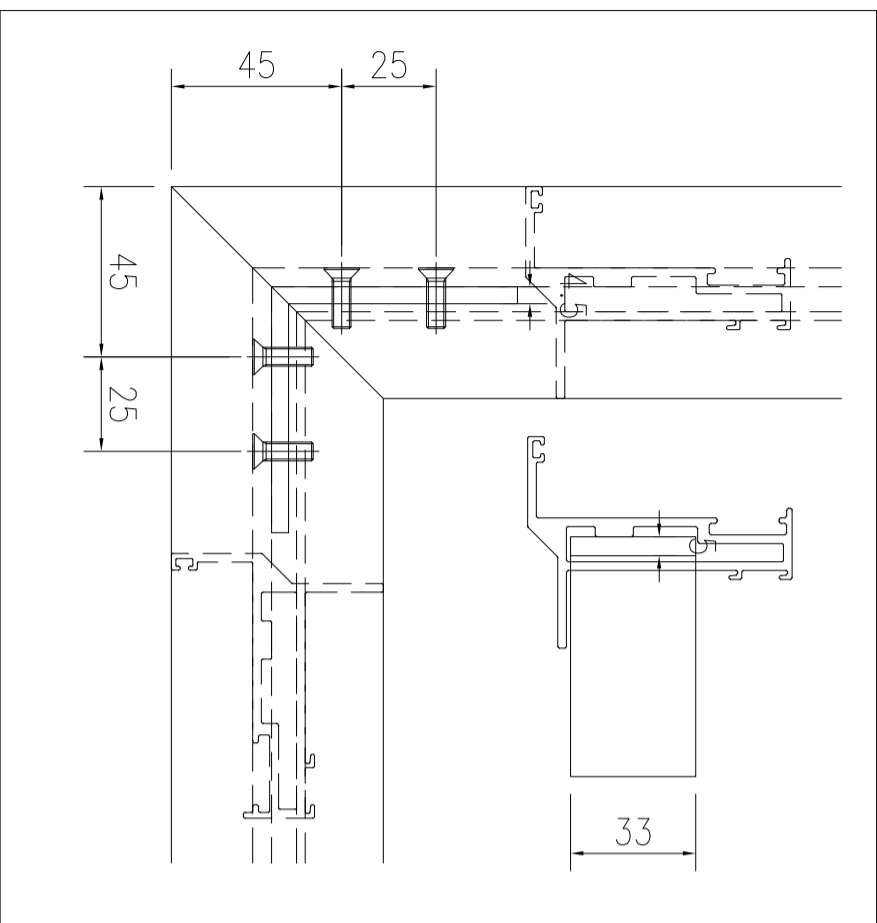

S.F.L.

B.O. REF :

CLIENT :

SUN HUNG KAI
REAL ESTATE AGENCY LTD.
42/F SUN HUNG KAI CENTRE, WANGCHAI, HONGKONG

ARCHITECT :

lwk&partners
a r c h i t e c t s

MAIN CONTRACTOR :

怡輝建築有限公司
Yee Fai Building Contractors Ltd.

STRUCTURAL ENGINEER :

ARUP

FAÇADE CONSULTANT:

ALPHA CONSULTING LIMITED
Steel Structure & Façade Specialist

NOTE :

1. ALL DIMENSIONS ARE IN mm.
2. ALL ELEVATIONS ARE VIEWED FROM OUTSIDE.
3. ALL DIMENSIONS TO BE VERIFIED ON SITE BEFORE FABRICATION.

LEGEND :

X1 --- DETAIL MARK NO.
X001 --- REFER SHEET NO.

1. F.F.L. --- FINISHED FLOOR LEVEL
2. S.F.L. --- STRUCTURAL FLOOR LEVEL
3. (R) --- REVERSED DETAIL

4. GLASS LEGEND

- EQ1-1 --- 6mmHS+12mm AIR GAP+10mmTP THK. I.G.U.
EQ1-2 --- 10mm THK. CLEAR TEMPERED GLASS
EQ1-4 --- 10mm THK. TEMPERED ACID ETCHED GLASS
EQ1-1A --- 6mmHS+12mm AIR GAP+8mmTP THK. I.G.U.

NO.	DATE	REVISION	BY

JOB NO. : J-856

PROJECT :
PROPOSED DEVELOPMENT ABOVE
LIGHT RAIL TIN WING STOP TSWTL
NO.23,AREA 33,TIN SHUI WAI, N.T.

TITLE :

ALUM. WINDOW SECTION
TYPICAL LOCK & HINGES DETAIL

DATE : 02-Aug-21 SCALE : 1:40

DRAWN BY : Ivorn CHECKED BY :

美特鋁質有限公司
MIDI ALUMINIUM FABRICATOR LTD.
Units 6-8, Sunny Industrial Centre, 1/F
610 Che Kwo Ling Road, Kowloon
Tel:23489211-4 Fax:8522727666

DWG NO. : JB56-SD-PW-DT74d REV. : -

50窗

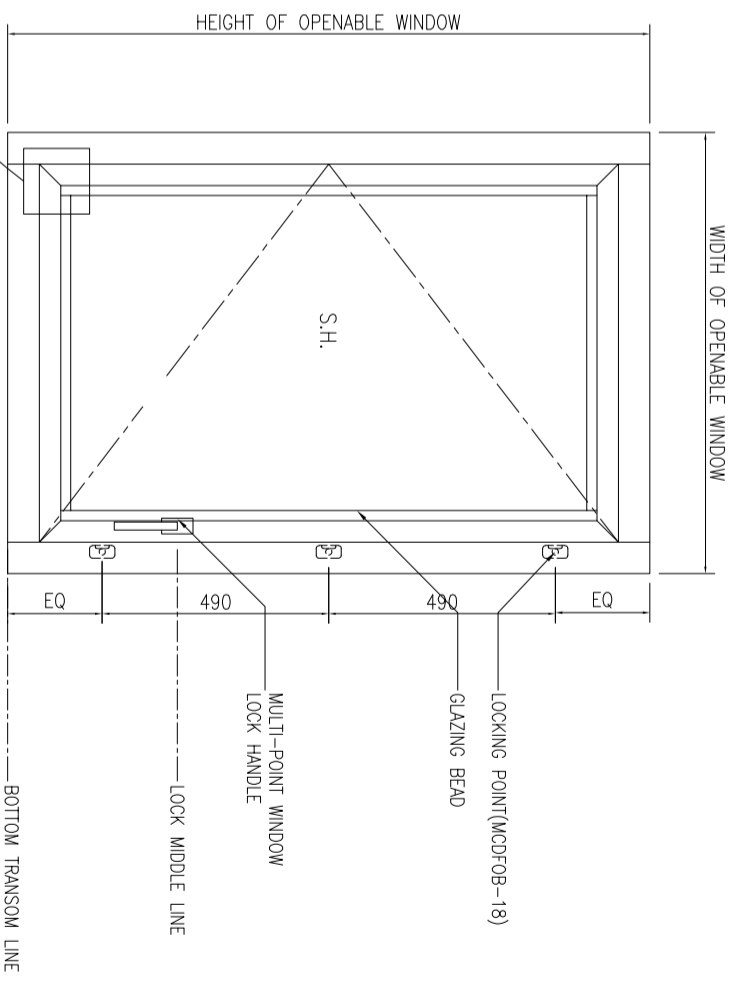
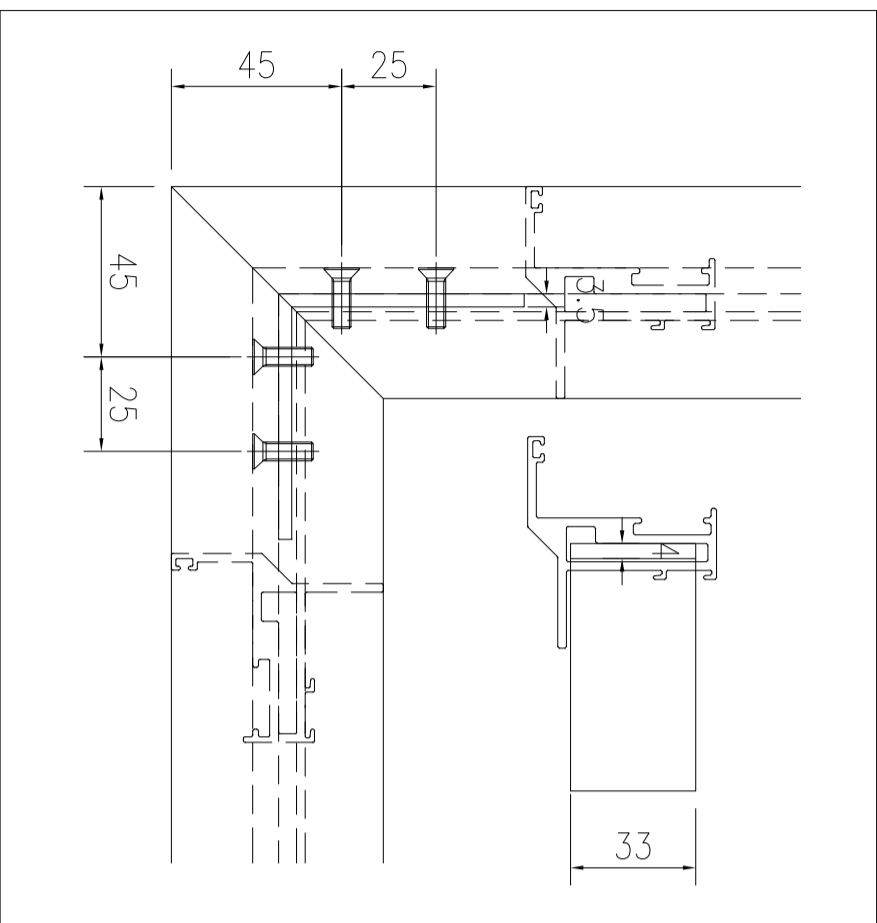

01 TYPICAL SECTION

S.F.L.

B.O. REF :

CLIENT :

SUN HUNG KAI
REAL ESTATE AGENCY LTD.
42/F SUN HUNG KAI CENTRE, WANGCHAI, HONGKONG

ARCHITECT :

IWK&partners
a r c h i t e c t s

MAIN CONTRACTOR :

怡輝建築有限公司
Yee Fai Building Contractors Ltd.

STRUCTURAL ENGINEER :

ARUP

FAÇADE CONSULTANT:

ALPHA CONSULTING LIMITED
Steel Structure & Façade Specialist

NOTE :

1. ALL DIMENSIONS ARE IN mm.
2. ALL ELEVATIONS ARE VIEWED FROM OUTSIDE.
3. ALL DIMENSIONS TO BE VERIFIED ON SITE BEFORE FABRICATION.

LEGEND :

X1 ——— DETAIL MARK NO.
X001 ——— REFER SHEET NO.

1. F.F.L. -- FINISHED FLOOR LEVEL
2. S.F.L. -- STRUCTURAL FLOOR LEVEL
3. (R) -- REVERSED DETAIL
4. GLASS LEGEND

EGL-1 -- 6mmHS+12mm AIR GAP+10mmTP THK. I.G.U.
 EGL-2 -- 10mm THK. CLEAR TEMPERED GLASS
 EGL-4 -- 10mm THK. TEMPERED ACID ETCHED GLASS
 EGL-1A -- 8mmHS+12mm AIR GAP+8mmTP THK. I.G.U.

NO.	DATE	REVISION	BY

JOB NO. : J-856

PROJECT :
 PROPOSED DEVELOPMENT ABOVE
 LIGHT RAIL TIN WING STOP TSWTL
 NO.23, AREA 33, TIN SHUI WAI, N.T.

TITLE :
 G.M.S FIXING LUG TYPICAL DETAIL
 FOR ALUM. WINDOW

DATE : 02-Aug-21 SCALE : 1:60
 DRAWN BY : ivon CHECKED BY :

美特鋁質有限公司
 MIDI ALUMINIUM FABRICATOR LTD.
 Units 6-8, Sunny Industrial Centre, 1/F
 610 Che Kwo Ling Road, Kowloon
 Tel:23489211-4 Fax:8522727666
 DWG NO. : J856-SD-PW-DT75 REV. : -

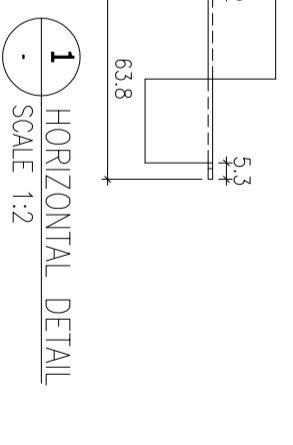
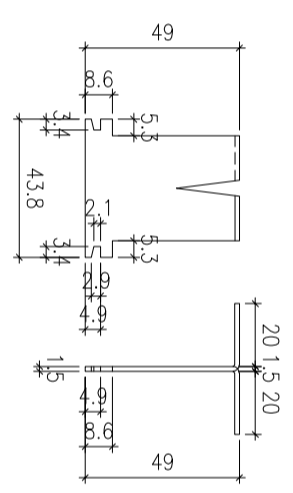
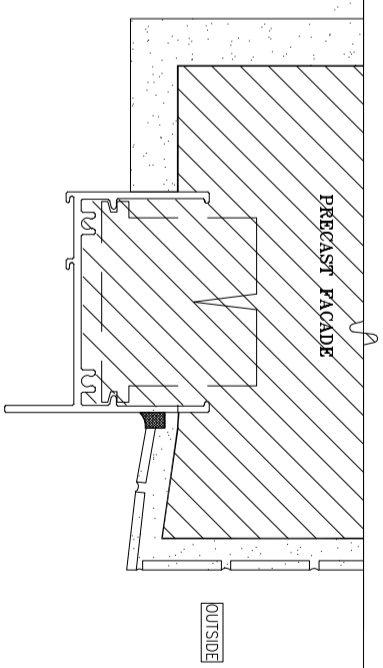
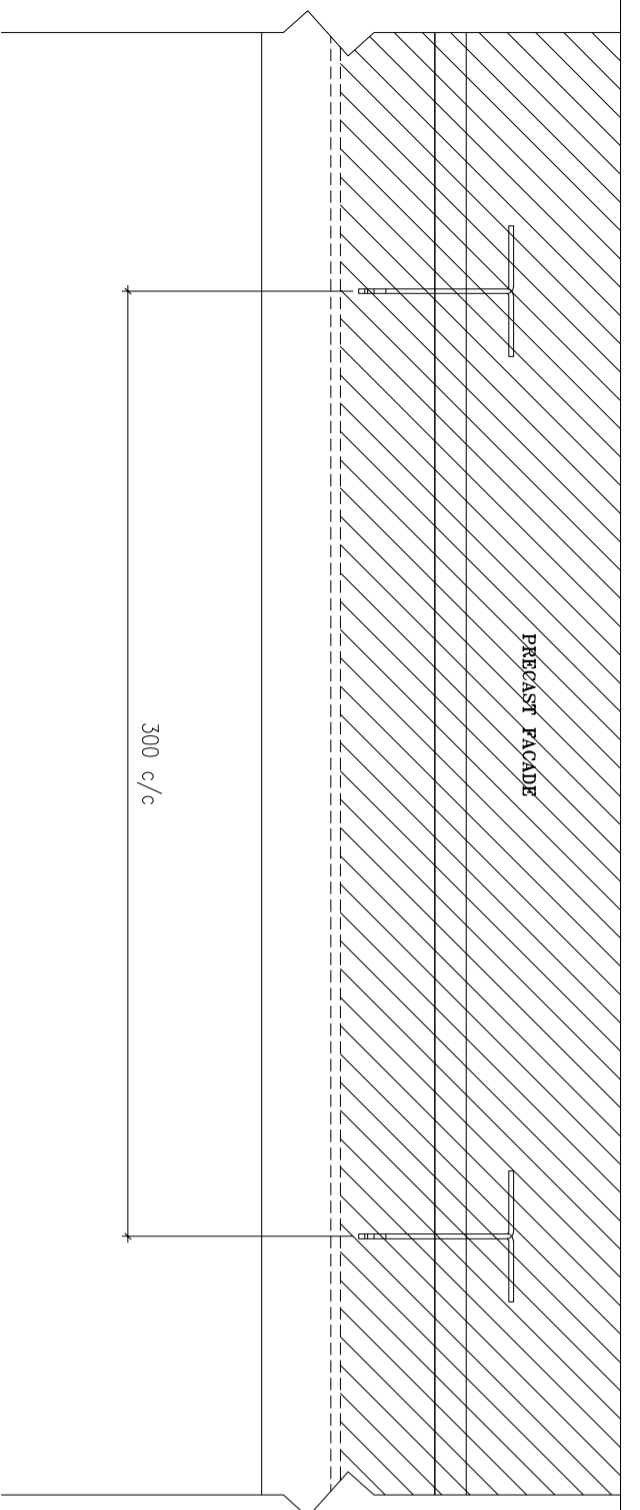

3 HORIZONTAL DETAIL SCALE 1:2

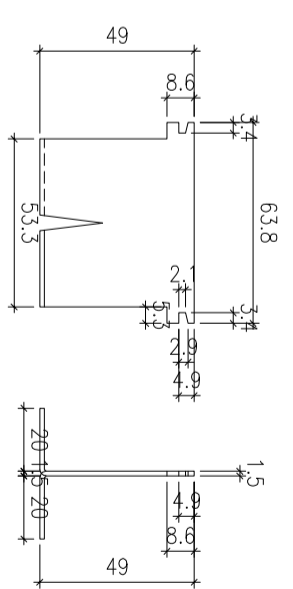

2 HORIZONTAL DETAIL SCALE 1:2

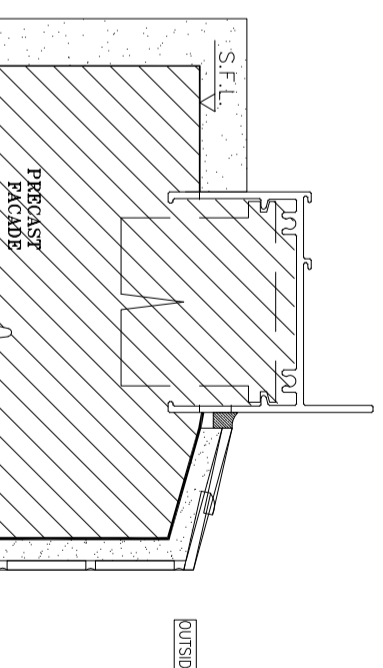
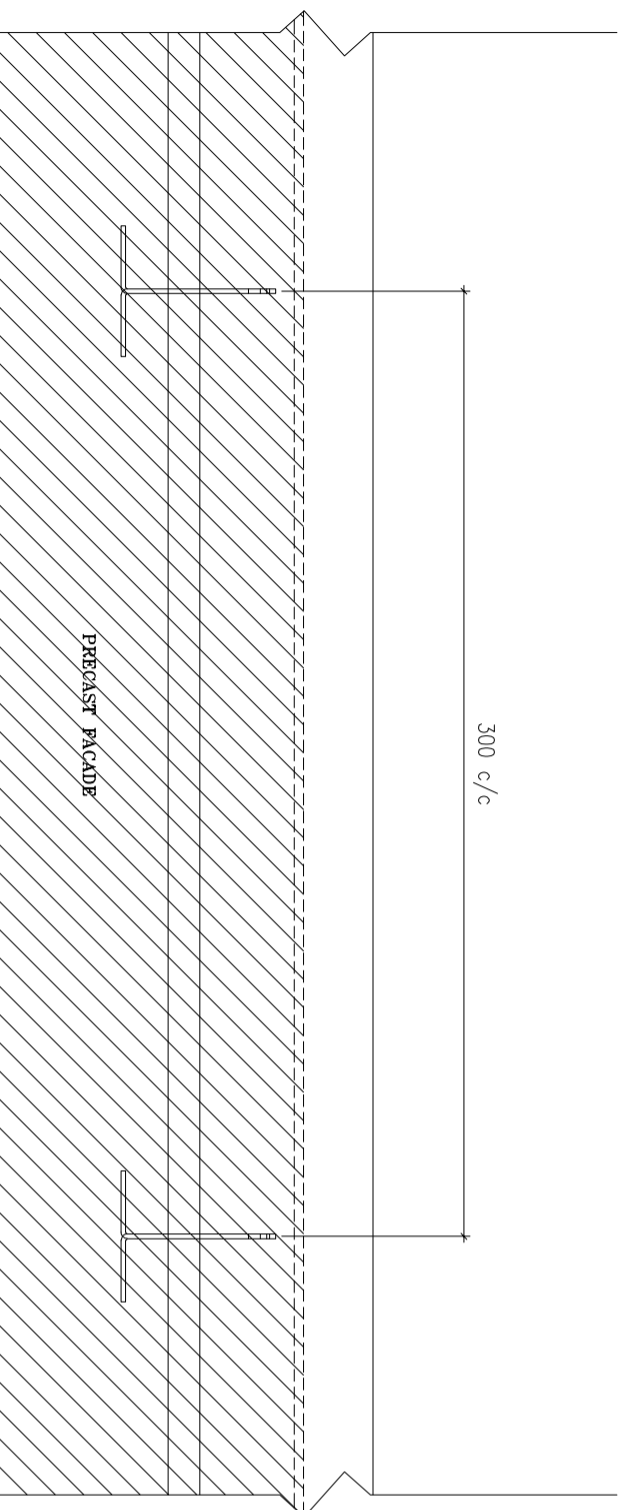
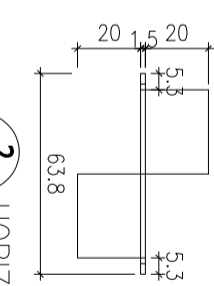

B.O. REF :

CLIENT :

SUN HUNG KAI
REAL ESTATE AGENCY LTD.
42/F SUN HUNG KAI CENTRE, WANGCHAI, HONGKONG

ARCHITECT :

IWK&partners
a r c h i t e c t s

MAIN CONTRACTOR :

怡輝建築有限公司
Yee Fai Building Contractors Ltd.

STRUCTURAL ENGINEER :

ARUP
FAÇADE CONSULTANT:

ALPHA CONSULTING LIMITED
Steel Structure & Façade Specialist

NOTE :

1. ALL DIMENSIONS ARE IN mm.
2. ALL ELEVATIONS ARE VIEWED FROM OUTSIDE.
3. ALL DIMENSIONS TO BE VERIFIED ON SITE BEFORE FABRICATION.

LEGEND :

X1 — DETAIL MARK NO.
X001 — REFER SHEET NO.

1. F.F.L.--FINISHED FLOOR LEVEL
2. S.F.L.--STRUCTURAL FLOOR LEVEL
3. (R) --REVERSED DETAIL

4. GLASS LEGEND

EG1-1--8mmHS+12mm AIR GAP+10mmTP THK. I.G.U.
EG1-2--10mm THK. CLEAR TEMPERED GLASS
EG1-4--10mm THK. TEMPERED ACID ETCHED GLASS
EG1-1A--8mmHS+12mm AIR GAP+8mmTP THK. I.G.U.

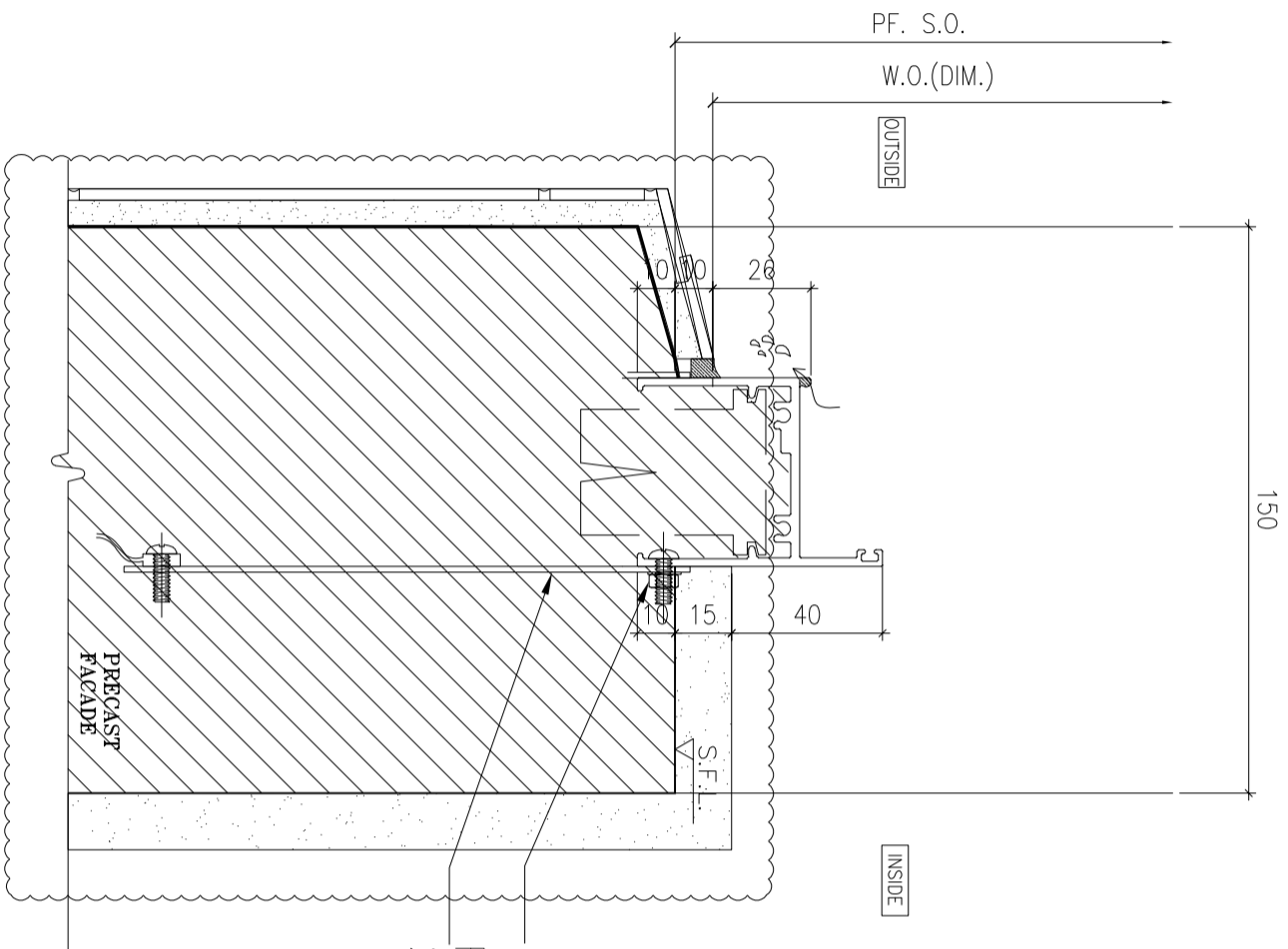

1 HORIZONTAL DETAIL
SCALE 1:2

TITLE : TYPICAL EARTHING

BONDING DETAILS OF PRECAST

DATE : 02-Aug-21 SCALE : 1:40

DRAWN BY : Ivorn CHECKED BY :

美特鋁質有限公司
MIDI ALUMINIUM FABRICATOR LTD.
Units 6-8, Sunny Industrial Centre, 1/F
610 Che Kwo Ling Road, Kowloon
Tel:23489211-4 Fax:8522727666
DWG NO. : JB56-SD-PW-DT76 REV. : A

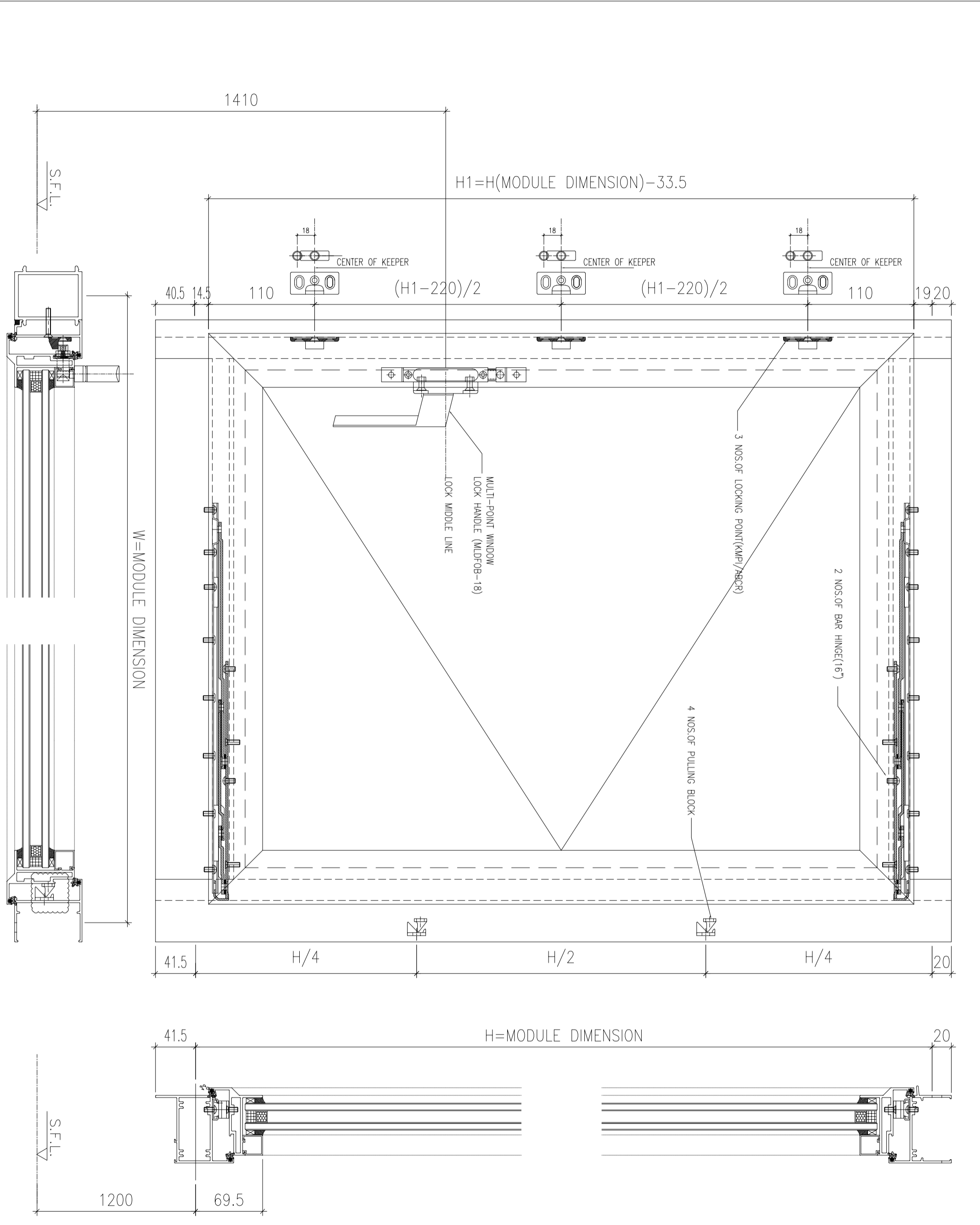

B.O. REF. :

CLIENT : **SUN HUNG KAI REAL ESTATE AGENCY LTD.**
42/F SUN HUNG KAI CENTRE, WANGCHAI, HONGKONG

ARCHITECT : **IWK&partners**
a r c h i t e c t s

MAIN CONTRACTOR : **怡輝建築有限公司**
Yee Fai Building Contractors Ltd.

STRUCTURAL ENGINEER : **ARUP**

FAÇADE CONSULTANT : **ALPHA CONSULTING LIMITED**
Steel Structure & Façade Specialist

NOTE :
1. ALL DIMENSIONS ARE IN mm.
2. ALL ELEVATIONS ARE VIEWED FROM OUTSIDE.
3. ALL DIMENSIONS TO BE VERIFIED ON SITE BEFORE FABRICATION.

LEGEND :
X1 --- DETAIL MARK NO.
X001 --- REFER SHEET NO.

1. F.F.L. -- FINISHED FLOOR LEVEL
2. S.F.L. -- STRUCTURAL FLOOR LEVEL
3. (R) -- REVERSED DETAIL
4. GLASS LEGEND
EG1-1 -- 8mmHS+12mm AIR GAP+10mmTP THK. I.G.U.
EG1-2 -- 10mm THK. CLEAR TEMPERED GLASS
EG1-4 -- 10mm THK. TEMPERED ACID ETCHED GLASS
EG1-1A -- 8mmHS+12mm AIR GAP+8mmTP THK. I.G.U.

NO.	DATE	REVISION SUBJECT TO ARCH/COMMENT	BY
A	03/01/2022	REVISION SUBJECT TO ARCH/COMMENT	WVN
NO.	DATE	REVISION	BY

JOB NO. : J-856

PROJECT : PROPOSED DEVELOPMENT ABOVE LIGHT RAIL TIN WING STOP TSWTL NO.23, AREA 33, TIN SHUI WAI, N.T.

TITLE : TYPICAL EARTHING BONDING DETAILS OF PRECAST

DATE : 02-Aug-21 SCALE : 1:60

DRAWN BY : I/von CHECKED BY :

美特鋁質有限公司
MIDI ALUMINIUM FABRICATOR LTD.
Units 6-8, Sunny Industrial Centre, 1/F
610 Che Kwo Ling Road, Kowloon
Tel:23489211-4 Fax:8522727666

DWG NO. : JB56-SD-PW-D1777 REV. : A

B.O. REF :

W=MODULE DIMENSION

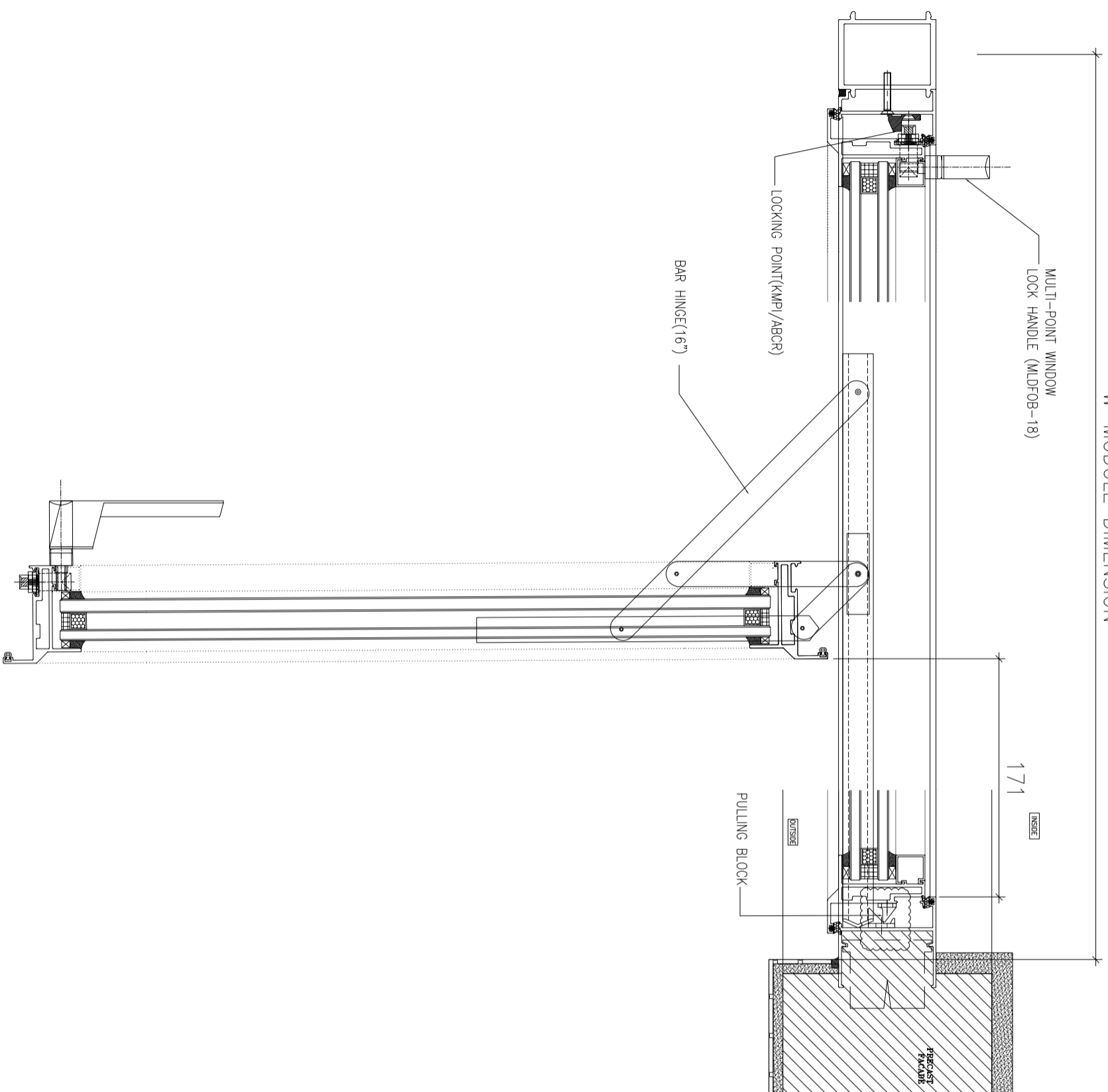

171 INSIDE

PULLING BLOCK OUTSIDE

CLIENT :
SUN HUNG KAI
 REAL ESTATE AGENCY LTD.
 42/F SUN HUNG KAI CENTRE, WANGCHAI, HONGKONG

ARCHITECT :
lwk&partners
 a r c h i t e c t s

MAIN CONTRACTOR :
怡輝建築有限公司
Yee Fai Building Contractors Ltd.

STRUCTURAL ENGINEER :
ARUP

FAÇADE CONSULTANT:
ALPHA CONSULTING LIMITED
 Steel Structure & Façade Specialist

NOTE :
 1. ALL DIMENSIONS ARE IN mm.
 2. ALL ELEVATIONS ARE VIEWED FROM OUTSIDE.
 3. ALL DIMENSIONS TO BE VERIFIED ON SITE BEFORE FABRICATION.

LEGEND :
 X1 --- DETAIL MARK NO.
 X001 --- REFER SHEET NO.

1. F.F.L.--FINISHED FLOOR LEVEL
2. S.F.L.--STRUCTURAL FLOOR LEVEL
3. (R) --REVERSED DETAIL
4. GLASS LEGEND
 EQL-1--8mmHS+12mm AIR GAP+10mmTP THK. I.G.U.
 EQL-2--10mm THK. CLEAR TEMPERED GLASS
 EQL-4--10mm THK. TEMPERED ACID ETCHED GLASS
 EQL-1A--8mmHS+12mm AIR GAP+8mmTP THK. I.G.U.

NO.	DATE	REVISION SUBJECT TO ARCH/COMMENT	BY
A	03/01/2022		

JOB NO. : J-856

PROJECT :
 PROPOSED DEVELOPMENT ABOVE
 LIGHT RAIL TIN WING STOP TSWTL
 NO.23,AREA 33,TIN SHUI WAI, N.T.

TITLE :
 TYPICAL EARTHING
 BONDING DETAILS OF PRECAST

DATE : 02-Aug-21 SCALE : 1:60

DRAWN BY : Ivorn CHECKED BY :

美特鋁質有限公司
MIDI ALUMINIUM FABRICATOR LTD.
 Units 6-8, Sunny Industrial Centre, 1/F
 610 Che Kwo Ling Road, Kowloon
 Tel:23489211-4 Fax:85212727666
 DWG NO. : J856-SD-PW-DT78 REV. : A