

工程指示 / 要求簡箋(E.I.)

工程指示編號：EI / 3986 / 21

修改版次：E

工程編號：J - 856

工程名稱：天水圍天榮站

工程項目：佛沙窗 大圖( 8th 大圖, T3)

收件人：生統 / 謝永林 / 王良 發件人：Eric Liu

日期：15/12/2021

要求提供 / 確認 事項：

- |                                    |                                     |                               |
|------------------------------------|-------------------------------------|-------------------------------|
| <input type="checkbox"/> 初步鋁料 B.M. | <input type="checkbox"/> 加工拆圖，然後生產  | <input type="checkbox"/> 尺寸表  |
| <input type="checkbox"/> 正式鋁料 B.M. | <input type="checkbox"/> 技術上資料 / 指示 | <input type="checkbox"/> 報價   |
| <input type="checkbox"/> 配件 B.M.   | <input type="checkbox"/> 樣辦或貨品說明書   | <input type="checkbox"/> 分判合約 |

內容：

E 版: 附上 8th 大圖(只有 T3)，請按此圖拆圖，T3 試模窗優先提供，另請提供保護方案

D 版: 附上 7th 大圖，請按此圖拆圖，另請提供保護方案

C 版: 附上 6TH 大圖，請按此圖拆圖，另請提供保護方案

B 版: 附上確認修改基仔做 560 高資料

A 版: 請查閱附件提供佛沙窗大圖 (5th submission)

優先計算鋁料 BM

王良: 請安排提供本項目使用的保護方案

謝謝

請在 2021.12.20 前完成上列要求。

附：

以上項目為：

- 原合約工程包                       原合約工程加 / 減賬                       新工程報價

原因：-

分發東莞各部門：

- ( ) 生產技術總監  連附件    ( ) 技術部  連附件 *王良*    ( ) 生產部  連附件    ( ) 機械設計部  連附件  
 ( ) 採購部  連附件    ( ) 生產統籌部  連附件 *王良*    ( ) 小羅 & 清  連附件  
 ( ) 質檢部  連附件    ( ) 會計部  連附件    ( ) 報關組  連附件    ( ) 其他 \_\_\_\_\_  連附件

分發其他分判：*王良*

- (v) 水洪  連附件

分發香港各部門：

- ( ) 行政部  連附件    ( ) 會計部  連附件    ( ) 統籌部  連附件    ( ) 工程部地盤科文  連附件  
 ( ) 採購部  連附件    ( ) QS 部  連附件    ( ) 維修部  連附件    ( ) 其他 \_\_\_\_\_  連附件

傳遞編號：

HK2287 / 21

發件人簽署：*Eric Liu*

項目經理簽署：*王良*

PROJECT :

7

PROPOSED DEVELOPMENT ABOVE  
LIGHT RAIL TIN WING STOP, TSWTL  
NO.23, AREA 33, TIN SHUI WAI, N.T.

SHOP DRAWING FOR ALUM. PRECAST WINDOW OF TOWER

DATE: 14-Dec-21

 美特鋁質有限公司  
MIDI ALUMINIUM FABRICATOR LTD.

Units 6-8, Sunray Industrial Centre, 1/F  
610 Cha Kwo Ling Road, Kowloon  
Tel:23489211-4 Fax:(852)27727666

# DRAWING SUBMISSION REGISTER

PROJECT: PROPOSED DEVELOPMENT ABOVE LIGHT RAIL TIN WING STOP, TSWTL NO.23, AREA 33, TIN SHUI WAI, N.T.		TITLE: ALUM. WINDOW OF TOWER SHOPDRAWING SUBMISSION		DATE OF ISSUE							SUBMISSION STATE (FOR B.D / A.S.D)		SUBMISSION STATE (FOR CLIENT / CONSULTANT)		SUBMISSION STATE (FOR ARCHITECT)		FABRICATION / CONSTRUCTION STATE							
DRAWING TITLE	DWG. NO.	ISSUE	1	2	3	4	5	6	7	COMMENT DATE	REV.	STATE	COMMENT DATE	REV.	STATE	COMMENT DATE	REV.	STATE	DATE	REV.	DATE	REV.	DATE	
		DAY	22	12	18	30	5	29	14															
		MONTH	9	10	10	10	11	11	12															
YEAR	21	21	21	21	21	21	21	21	21	AP - APPROVED AC - APPROVED SUB. TO CONDITION NA - NOT APPROVED		AP - APPROVED AC - APPROVED SUB. TO CONDITION NA - NOT APPROVED		AP - APPROVED AC - APPROVED SUB. TO CONDITION NA - NOT APPROVED		ISSUE TO CHINA OFFICE	ISSUE TO SITE	ISSUE TO SUB-CONTRACTOR						
COVER PAGE	J856-SD-PW-0000	-	A	B	C	D	E	F																
DRAWING REGISTER	J856-SD-PW-0001	-	A	A	A	B	C	D																
DRAWING REGISTER	J856-SD-PW-0002	-	A	A	A	B	C	D																
DRAWING REGISTER	J856-SD-PW-0003	-	A	B	B	C	D	E																
DRAWING REGISTER	J856-SD-PW-0004	-	A	B	B	B	B	C																
DRAWING REGISTER	J856-SD-PW-0005	-	A	B	B	C	C	D																
GENERAL NOTES FOR ALUM. WINDOW	J856-SD-PW-GN01	-	-	-	-	-	-	-																
EXTRUSION LIST FOR ALUM. WINDOW	J856-SD-PW-1101	-	A	A	A	A	B	B																
EXTRUSION LIST FOR ALUM. WINDOW	J856-SD-PW-1102	-	-	-	A	A	A	A																
PLAN FOR ALUM. WINDOW AT TOWER 1(3/F)	J856-SD-PW-3101	-	-	-	-	-	-	-	A															
PLAN FOR ALUM. WINDOW AT TOWER 1(6/F-22/F)	J856-SD-PW-3102	-	A	A	A	B	C																	
PLAN FOR ALUM. WINDOW AT TOWER 1(43/F)	J856-SD-PW-3103	-	-	-	-	-	-	-																
PLAN FOR ALUM. WINDOW AT TOWER 1(45/F)	J856-SD-PW-3104	-	-	-	-	-	-	-																
PLAN FOR ALUM. WINDOW AT TOWER 1(46/F)	J856-SD-PW-3105	-	-	-	-	-	-	-																
PLAN FOR ALUM. WINDOW AT TOWER 2(3/F)	J856-SD-PW-3201	-	-	-	-	-	-	-	A															
PLAN FOR ALUM. WINDOW AT TOWER 2(6/F-42/F)	J856-SD-PW-3202	-	A	A	A	B	C																	
PLAN FOR ALUM. WINDOW AT TOWER 2(43/F)	J856-SD-PW-3203	-	-	-	-	-	-	-																
PLAN FOR ALUM. WINDOW AT TOWER 2(45/F)	J856-SD-PW-3204	-	-	-	-	-	-	-																
PLAN FOR ALUM. WINDOW AT TOWER 2(46/F)	J856-SD-PW-3205	-	-	-	-	-	-	-	A															
PLAN FOR ALUM. WINDOW AT TOWER 3(3/F)	J856-SD-PW-3301	-	-	-	-	-	-	-																
PLAN FOR ALUM. WINDOW AT TOWER 3(6/F-42/F)	J856-SD-PW-3302	-	A	B	C	D	E																	
PLAN FOR ALUM. WINDOW AT TOWER 3(43/F)	J856-SD-PW-3303	-	-	-	-	-	-	-																
PLAN FOR ALUM. WINDOW AT TOWER 3(45/F)	J856-SD-PW-3304	-	-	-	-	-	-	-																
PLAN FOR ALUM. WINDOW AT TOWER 3(46/F)	J856-SD-PW-3305	-	-	-	-	-	-	-																
WINDOW SCHEDULE FOR TOWER 1 ALUM. WINDOW	J856-SD-PW-5101	-	A	A	A	B	C																	
WINDOW SCHEDULE FOR TOWER 1 ALUM. WINDOW	J856-SD-PW-5102	-	-	-	-	A	B																	
WINDOW SCHEDULE FOR TOWER 1 ALUM. WINDOW	J856-SD-PW-5103	-	-	-	-	A	B																	
WINDOW SCHEDULE FOR TOWER 1 ALUM. WINDOW	J856-SD-PW-5104	-	A	A	A	B	C																	
WINDOW SCHEDULE FOR TOWER 1 ALUM. WINDOW	J856-SD-PW-5105	-	-	-	-	A	B																	
WINDOW SCHEDULE FOR TOWER 1 ALUM. WINDOW	J856-SD-PW-5106	-	A	A	A	B	C																	
WINDOW SCHEDULE FOR TOWER 1 ALUM. WINDOW	J856-SD-PW-5107	-	-	-	-	A	B																	
WINDOW SCHEDULE FOR TOWER 1 ALUM. WINDOW	J856-SD-PW-5108	-	-	-	-	A	B																	
WINDOW SCHEDULE FOR TOWER 1 ALUM. WINDOW	J856-SD-PW-5109	-	A	A	A	B	C																	
WINDOW SCHEDULE FOR TOWER 1 ALUM. WINDOW	J856-SD-PW-5110	-	A	A	A	B	C																	
WINDOW SCHEDULE FOR TOWER 1 ALUM. WINDOW	J856-SD-PW-5111	-	A	A	A	B	C																	
WINDOW SCHEDULE FOR TOWER 1 ALUM. WINDOW	J856-SD-PW-5112	-	A																					
WINDOW SCHEDULE FOR TOWER 1 ALUM. WINDOW	J856-SD-PW-5113	-	A																					
WINDOW SCHEDULE FOR TOWER 1 ALUM. WINDOW	J856-SD-PW-5114	-	A																					
WINDOW SCHEDULE FOR TOWER 1 ALUM. WINDOW	J856-SD-PW-5115	-	-	-	-	-	-	-																
WINDOW SCHEDULE FOR TOWER 1 ALUM. WINDOW	J856-SD-PW-5116	-	-	-	-	-	-	-																
WINDOW SCHEDULE FOR TOWER 1 ALUM. WINDOW	J856-SD-PW-5117	-	A																					
WINDOW SCHEDULE FOR TOWER 1 ALUM. WINDOW	J856-SD-PW-5118	-	A																					

IN-HOUSE DESIGN CHECKER

# DRAWING SUBMISSION REGISTER

**PROJECT:**  
**PROPOSED DEVELOPMENT ABOVE**  
**LIGHT RAIL TIN WING STOP, TSWTL**  
**NO.23, AREA 33, TIN SHUI WAI, N.T.**  
**TITLE:**  
**ALUM. WINDOW OF TOWER**  
**SHOPDRAWING SUBMISSION**

DRAWING TITLE	DWG. NO.	DATE OF ISSUE							SUBMISSION STATE (FOR B.D / A.S.D)			SUBMISSION STATE (FOR CLIENT / CONSULTANT)			SUBMISSION STATE (FOR ARCHITECT)			FABRICATION / CONSTRUCTION STATE				
		ISSUE	1	2	3	4	5	6	7	AP - APPROVED	AC - APPROVED SUB. TO CONDITION	NA - NOT APPROVED	AP - APPROVED	AC - APPROVED SUB. TO CONDITION	NA - NOT APPROVED	AP - APPROVED	AC - APPROVED SUB. TO CONDITION	NA - NOT APPROVED	ISSUE TO CHINA OFFICE	ISSUE TO SITE	ISSUE TO SUB-CONTRACTOR	
		DAY	22	12	18	30	2	29	14													
WINDOW SCHEDULE FOR TOWER 1 ALUM. WINDOW	J856-SD-PW-5119	-	A																			
WINDOW SCHEDULE FOR TOWER 1 ALUM. WINDOW	J856-SD-PW-5120	-	A																			
WINDOW SCHEDULE FOR TOWER 1 ALUM. WINDOW	J856-SD-PW-5121	-	A																			
WINDOW SCHEDULE FOR TOWER 1 ALUM. WINDOW	J856-SD-PW-5122	-	A																			
WINDOW SCHEDULE FOR TOWER 1 ALUM. WINDOW	J856-SD-PW-5123	-	-																			
WINDOW SCHEDULE FOR TOWER 1 ALUM. WINDOW	J856-SD-PW-5124	-	-																			
WINDOW SCHEDULE FOR TOWER 1 ALUM. WINDOW	J856-SD-PW-5125	-	A																			
WINDOW SCHEDULE FOR TOWER 1 ALUM. WINDOW	J856-SD-PW-5126	-	A																			
WINDOW SCHEDULE FOR TOWER 1 ALUM. WINDOW	J856-SD-PW-5127	-	-																			
WINDOW SCHEDULE FOR TOWER 1 ALUM. WINDOW	J856-SD-PW-5128	-	-																			
WINDOW SCHEDULE FOR TOWER 1 ALUM. WINDOW	J856-SD-PW-5129	-	-																			
WINDOW SCHEDULE FOR TOWER 1 ALUM. WINDOW	J856-SD-PW-5130	-	-																			
WINDOW SCHEDULE FOR TOWER 1 ALUM. WINDOW	J856-SD-PW-5131	-	-																			
WINDOW SCHEDULE FOR TOWER 1 ALUM. WINDOW	J856-SD-PW-5132	-	-																			
WINDOW SCHEDULE FOR TOWER 1 ALUM. WINDOW	J856-SD-PW-5133	-	-																			
WINDOW SCHEDULE FOR TOWER 1 ALUM. WINDOW	J856-SD-PW-5134	-	-																			
WINDOW SCHEDULE FOR TOWER 1 ALUM. WINDOW	J856-SD-PW-5135	-	-																			
WINDOW SCHEDULE FOR TOWER 1 ALUM. WINDOW	J856-SD-PW-5136	-	-																			
WINDOW SCHEDULE FOR TOWER 1 ALUM. WINDOW	J856-SD-PW-5137	-	-																			
WINDOW SCHEDULE FOR TOWER 1 ALUM. WINDOW	J856-SD-PW-5138	-	-																			
WINDOW SCHEDULE FOR TOWER 1 ALUM. WINDOW	J856-SD-PW-5139	-	-																			
WINDOW SCHEDULE FOR TOWER 1 ALUM. WINDOW	J856-SD-PW-5140	-	-																			
WINDOW SCHEDULE FOR TOWER 1 ALUM. WINDOW	J856-SD-PW-5141	-	-																			
WINDOW SCHEDULE FOR TOWER 1 ALUM. WINDOW	J856-SD-PW-5142	-	-																			
WINDOW SCHEDULE FOR TOWER 1 ALUM. WINDOW	J856-SD-PW-5143	-	-																			
WINDOW SCHEDULE FOR TOWER 1 ALUM. WINDOW	J856-SD-PW-5144	-	-																			
WINDOW SCHEDULE FOR TOWER 1 ALUM. WINDOW	J856-SD-PW-5145	-	-																			
WINDOW SCHEDULE FOR TOWER 2 ALUM. WINDOW	J856-SD-PW-5201	-	A	A	A	B	C															
WINDOW SCHEDULE FOR TOWER 2 ALUM. WINDOW	J856-SD-PW-5202	-	-	-	-	A	B															
WINDOW SCHEDULE FOR TOWER 2 ALUM. WINDOW	J856-SD-PW-5203	-	-	-	-	A	B															
WINDOW SCHEDULE FOR TOWER 2 ALUM. WINDOW	J856-SD-PW-5204	-	A	A	A	B	C															
WINDOW SCHEDULE FOR TOWER 2 ALUM. WINDOW	J856-SD-PW-5205	-	-	-	-	A	B															
WINDOW SCHEDULE FOR TOWER 2 ALUM. WINDOW	J856-SD-PW-5206	-	A	A	A	B	C															
WINDOW SCHEDULE FOR TOWER 2 ALUM. WINDOW	J856-SD-PW-5207	-	-	-	-	A	B															
WINDOW SCHEDULE FOR TOWER 2 ALUM. WINDOW	J856-SD-PW-5208	-	-	-	-	A	B															
WINDOW SCHEDULE FOR TOWER 2 ALUM. WINDOW	J856-SD-PW-5209	-	A	A	A	B	C															
WINDOW SCHEDULE FOR TOWER 2 ALUM. WINDOW	J856-SD-PW-5210	-	A	A	A	B	C															
WINDOW SCHEDULE FOR TOWER 2 ALUM. WINDOW	J856-SD-PW-5211	-	A	A	A	B	C															
WINDOW SCHEDULE FOR TOWER 2 ALUM. WINDOW	J856-SD-PW-5211a	/	-	-	-																	
WINDOW SCHEDULE FOR TOWER 2 ALUM. WINDOW	J856-SD-PW-5212	-	-	-	-																	
WINDOW SCHEDULE FOR TOWER 2 ALUM. WINDOW	J856-SD-PW-5213	-	-	-	-																	
WINDOW SCHEDULE FOR TOWER 2 ALUM. WINDOW	J856-SD-PW-5214	-	A																			
WINDOW SCHEDULE FOR TOWER 2 ALUM. WINDOW	J856-SD-PW-5215	-	A																			

IN-HOUSE DESIGN CHECKER



**業特鋁質有限公司**  
**MIDI ALUMINIUM FABRICATOR LTD.**  
 Units 6-8, Sunray Industrial Centre, 1/F,  
 610 Chee Kwo Ling Road, Kowloon  
 Tel: 23489211-4 Fax: (852) 27727666  
 DWG NO. : J856-SD-PW-0002 REV. : D



# DRAWING SUBMISSION REGISTER

PROJECT: PROPOSED DEVELOPMENT ABOVE LIGHT RAIL TIN WING STOP, TSWTL NO.23, AREA 33, TIN SHUI WAI, N. T. TITLE: ALUM. WINDOW OF TOWER SHOPDRAWING SUBMISSION		DATE OF ISSUE						SUBMISSION STATE (FOR B.D / A.S.D)		SUBMISSION STATE (FOR CLIENT / CONSULTANT)		SUBMISSION STATE (FOR ARCHITECT)		FABRICATION / CONSTRUCTION STATE						
		ISSUE DAY	1	2	3	4	5	6	AP - APPROVED AC - APPROVED SUB. TO CONDITION NA - NOT APPROVED	AP - APPROVED AC - APPROVED SUB. TO CONDITION NA - NOT APPROVED	AP - APPROVED AC - APPROVED SUB. TO CONDITION NA - NOT APPROVED	ISSUE TO CHINA OFFICE	ISSUE TO SITE	ISSUE TO SUB-CONTRACTOR	REV.	DATE	REV.	DATE		
DRAWING TITLE	DWG. NO.	REVISIONS						COMMENT DATE	REV.	STATE	COMMENT DATE	REV.	STATE	COMMENT DATE	REV.	STATE	REV.	DATE	REV.	DATE
WINDOW SCHEDULE FOR TOWER 3 ALUM. WINDOW	J856-SD-PW-5316	-	-	A																
WINDOW SCHEDULE FOR TOWER 3 ALUM. WINDOW	J856-SD-PW-5317	-	-	A	B															
WINDOW SCHEDULE FOR TOWER 3 ALUM. WINDOW	J856-SD-PW-5318	-	-	A																
WINDOW SCHEDULE FOR TOWER 3 ALUM. WINDOW	J856-SD-PW-5319	-	-	A																
WINDOW SCHEDULE FOR TOWER 3 ALUM. WINDOW	J856-SD-PW-5320	-	-	A	B															
WINDOW SCHEDULE FOR TOWER 3 ALUM. WINDOW	J856-SD-PW-5321	-	-	A	B															
WINDOW SCHEDULE FOR TOWER 3 ALUM. WINDOW	J856-SD-PW-5322	-	-	A																
WINDOW SCHEDULE FOR TOWER 3 ALUM. WINDOW	J856-SD-PW-5323	-	-	A																
WINDOW SCHEDULE FOR TOWER 3 ALUM. WINDOW	J856-SD-PW-5324	-	-	A	B															
WINDOW SCHEDULE FOR TOWER 3 ALUM. WINDOW	J856-SD-PW-5325	-	-	A																
WINDOW SCHEDULE FOR TOWER 3 ALUM. WINDOW	J856-SD-PW-5326	-	-	A																
WINDOW SCHEDULE FOR TOWER 3 ALUM. WINDOW	J856-SD-PW-5327	-	-	A	B															
WINDOW SCHEDULE FOR TOWER 3 ALUM. WINDOW	J856-SD-PW-5328	-	-	A	B															
WINDOW SCHEDULE FOR TOWER 3 ALUM. WINDOW	J856-SD-PW-5329	-	-	A																
WINDOW SCHEDULE FOR TOWER 3 ALUM. WINDOW	J856-SD-PW-5330	-	-	A	B															
WINDOW SCHEDULE FOR TOWER 3 ALUM. WINDOW	J856-SD-PW-5331	-	-	A	B															
WINDOW SCHEDULE FOR TOWER 3 ALUM. WINDOW	J856-SD-PW-5332	-	-	A	B															
WINDOW SCHEDULE FOR TOWER 3 ALUM. WINDOW	J856-SD-PW-5333	-	-	A	B															
WINDOW SCHEDULE FOR TOWER 3 ALUM. WINDOW	J856-SD-PW-5334	-	-	A	B															
WINDOW SCHEDULE FOR TOWER 3 ALUM. WINDOW	J856-SD-PW-5335	-	-	A	B															
WINDOW SCHEDULE FOR TOWER 3 ALUM. WINDOW	J856-SD-PW-5336	-	-	A																
WINDOW SCHEDULE FOR TOWER 3 ALUM. WINDOW	J856-SD-PW-5337	-	-	A																
WINDOW SCHEDULE FOR TOWER 3 ALUM. WINDOW	J856-SD-PW-5338	-	-	A																
WINDOW SCHEDULE FOR TOWER 3 ALUM. WINDOW	J856-SD-PW-5339	-	-	A																
WINDOW SCHEDULE FOR TOWER 3 ALUM. WINDOW	J856-SD-PW-5340	-	-	A																
WINDOW SCHEDULE FOR TOWER 3 ALUM. WINDOW	J856-SD-PW-5341	-	-																	
WINDOW SCHEDULE FOR TOWER 3 ALUM. WINDOW	J856-SD-PW-5342	-	-																	
WINDOW SCHEDULE FOR TOWER 3 ALUM. WINDOW	J856-SD-PW-5343	-	-																	
WINDOW SCHEDULE FOR TOWER 3 ALUM. WINDOW	J856-SD-PW-5344	-	-																	
WINDOW SCHEDULE FOR TOWER 3 ALUM. WINDOW	J856-SD-PW-5345	-	-																	
WINDOW SCHEDULE FOR TOWER 3 ALUM. WINDOW	J856-SD-PW-5346	-	-																	
WINDOW SCHEDULE FOR TOWER 3 ALUM. WINDOW	J856-SD-PW-5347	-	-																	
WINDOW SCHEDULE FOR TOWER 3 ALUM. WINDOW	J856-SD-PW-5348	-	-																	
WINDOW SCHEDULE FOR TOWER 3 ALUM. WINDOW	J856-SD-PW-5349	-	-																	
WINDOW SCHEDULE FOR TOWER 3 ALUM. WINDOW	J856-SD-PW-5350	-	-																	
WINDOW SCHEDULE FOR TOWER 3 ALUM. WINDOW	J856-SD-PW-5351	-	-																	
WINDOW SCHEDULE FOR TOWER 3 ALUM. WINDOW	J856-SD-PW-5352	-	-																	
WINDOW SCHEDULE FOR TOWER 3 ALUM. WINDOW	J856-SD-PW-5353	-	-																	
WINDOW SCHEDULE FOR TOWER 3 ALUM. WINDOW	J856-SD-PW-5354	-	-																	
WINDOW SCHEDULE FOR TOWER 3 ALUM. WINDOW	J856-SD-PW-5355	-	-																	
WINDOW SCHEDULE FOR TOWER 3 ALUM. WINDOW	J856-SD-PW-5356	-	-																	
WINDOW SCHEDULE FOR TOWER 3 ALUM. WINDOW	J856-SD-PW-5357	-	-																	

IN-HOUSE DESIGN CHECKER







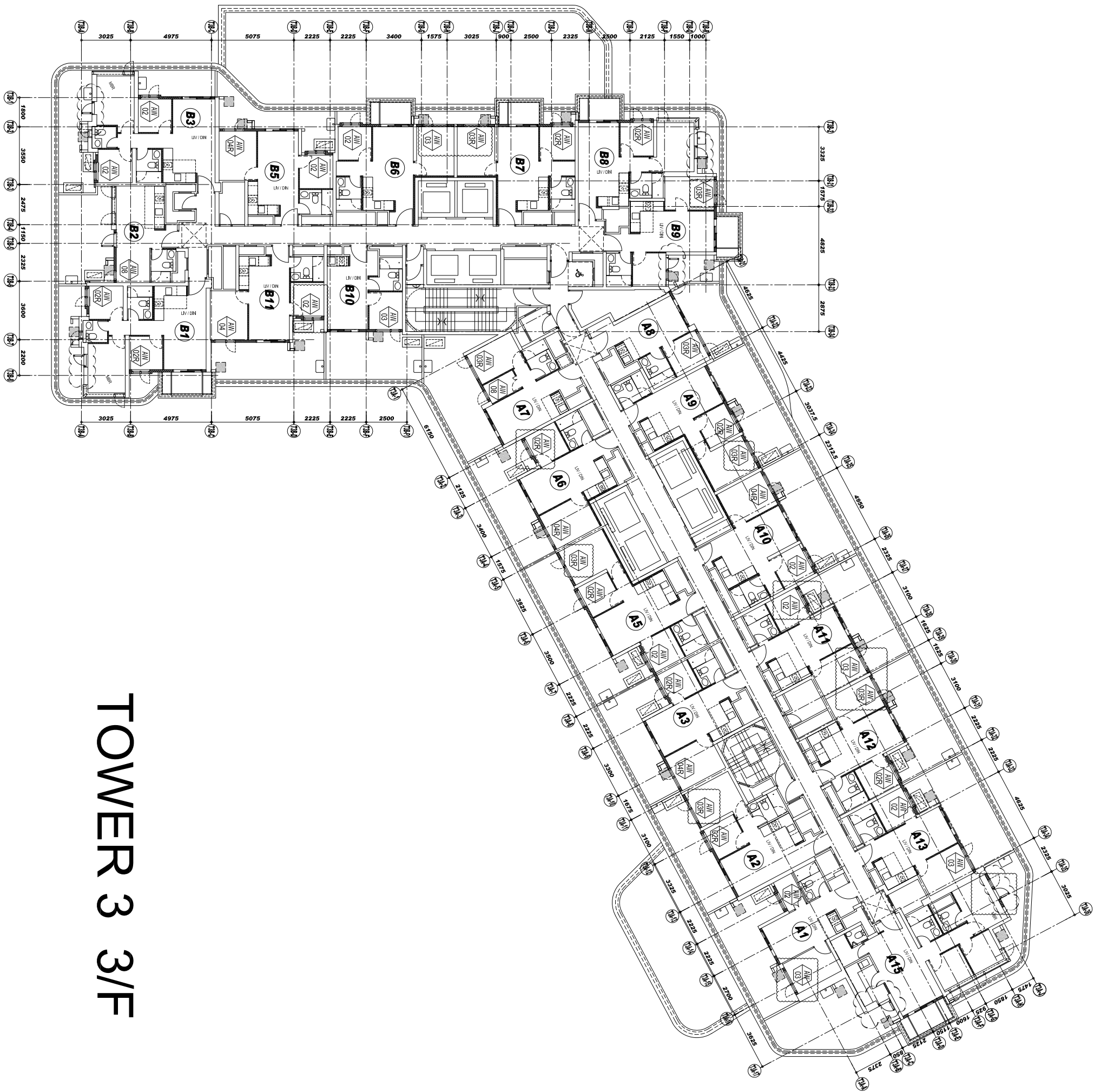

# TOWER 3 3/F

CLIENT :



ARCHITECT :



MAIN CONTRACTOR :



STRUCTURAL ENGINEER :



FAÇADE CONSULTANT:



NOTE :

1. ALL DIMENSIONS ARE IN mm.
2. ALL ELEVATIONS ARE VIEWED FROM OUTSIDE.
3. ALL DIMENSIONS TO BE VERIFIED ON SITE BEFORE FABRICATION.

LEGEND :

- ⊗11— DETAIL MARK NO.
- ⊗001— REFER SHEET NO.

1. F.F.L.--FINISHED FLOOR LEVEL
2. S.F.L.--STRUCTURAL FLOOR LEVEL
3. Ⓡ --REVERSED DETAIL
4. GLASS LEGEND

EQ.1--8mmHS+12mm AIR GAP+8mmTP THK. L.G.U.  
 EQ.2--10mm THK. CLEAR TEMPERED GLASS  
 EQ.4--10mm THK. TEMPERED ACID ETCHED GLASS

NO.	DATE	REVISION SUBJECT TO ADOPTMENT	BY
A.	29/11/2021	REVISION SUBJECT TO ADOPTMENT	WON

JOB NO. : J-856

PROJECT : PROPOSED DEVELOPMENT ABOVE LIGHT RAIL TIN WING STOP TSWTL NO.23,AREA 33,TIN SHUI WAI, N.T.

TITLE : PLAN FOR ALUM. WINDOW AT TOWER 3

DATE : 02-Aug-21 SCALE : 1:40

DRAWN BY : Iwon CHECKED BY :

**美特铝业有限公司**  
**MIDI ALUMINIUM FABRICATOR LTD.**  
 Units 6-8, Sunray Industrial Centre, 1/F  
 610 Chee Kwong Road, Kowloon  
 Tel:23489211-4 Fax:(852)2727866  
 DWG NO. : J856-SD-PW-3301 REV. : A

B.O. REF :

CLIENT :

**SUN HUNG KAI**  
REAL ESTATE AGENCY LTD.

42/F SUN HUNG KAI CENTRE, WINGHUA, HONGKONG

ARCHITECT :

**IWK&partners**  
A R C H I T E C T S

MAIN CONTRACTOR :

**怡輝建築有限公司**  
**Yee Fai** Building Contractors Ltd.

STRUCTURAL ENGINEER :

**ARUP**

FAÇADE CONSULTANT:

**ALPHA CONSULTING LIMITED**  
Steel Structure & Façade Specialist

NOTE :

1. ALL DIMENSIONS ARE IN mm.
2. ALL ELEVATIONS ARE VIEWED FROM OUTSIDE.
3. ALL DIMENSIONS TO BE VERIFIED ON SITE BEFORE FABRICATION.

LEGEND :

(X1) — DETAIL MARK NO.  
(X001) — REFER SHEET NO.

1. F.F.L. — FINISHED FLOOR LEVEL
2. S.F.L. — STRUCTURAL FLOOR LEVEL
3. (R) — REVERSED DETAIL
4. GLASS LEGEND

EGL-1 — 8mmHS+12mm AIR GAP+8mmTP THK. L.G.U.  
EGL-2 — 10mm THK. CLEAR TEMPERED GLASS  
EGL-4 — 10mm THK. TEMPERED ACID ETCHED GLASS

NO.	DATE	REVISION	REVISION SUBJECT TO ARCHITECTMENT
E	29/11/2021		REVISION SUBJECT TO ARCHITECTMENT
D	02/11/2021		REVISION SUBJECT TO ARCHITECTMENT
C	26/10/2021		REVISION SUBJECT TO ARCHITECTMENT
B	18/10/2021		REVISION SUBJECT TO ARCHITECTMENT
A	30/09/2021		REVISION SUBJECT TO ARCHITECTMENT

JOB NO. : J-856

PROJECT :

PROPOSED DEVELOPMENT ABOVE  
LIGHT RAIL TIN WING STOP TSWTL  
NO.23,AREA 33,TIN SHUI WAI, N.T.

TITLE :

PLAN FOR IN-SITU WINDOW  
AT TOWER 3

DATE : 02-Aug-21 SCALE : 1:40

DRAWN BY : Iwon CHECKED BY :

**美特鋁質有限公司**  
**MIDI ALUMINIUM FABRICATOR LTD.**

Units 6-8, Sunray Industrial Centre, 1/F  
610 Cho Kwong Road, Kowloon  
Tel:23489211-4 Fax:(852)27277866

DWG NO. : J856-SD-IW-3302 REV. : E

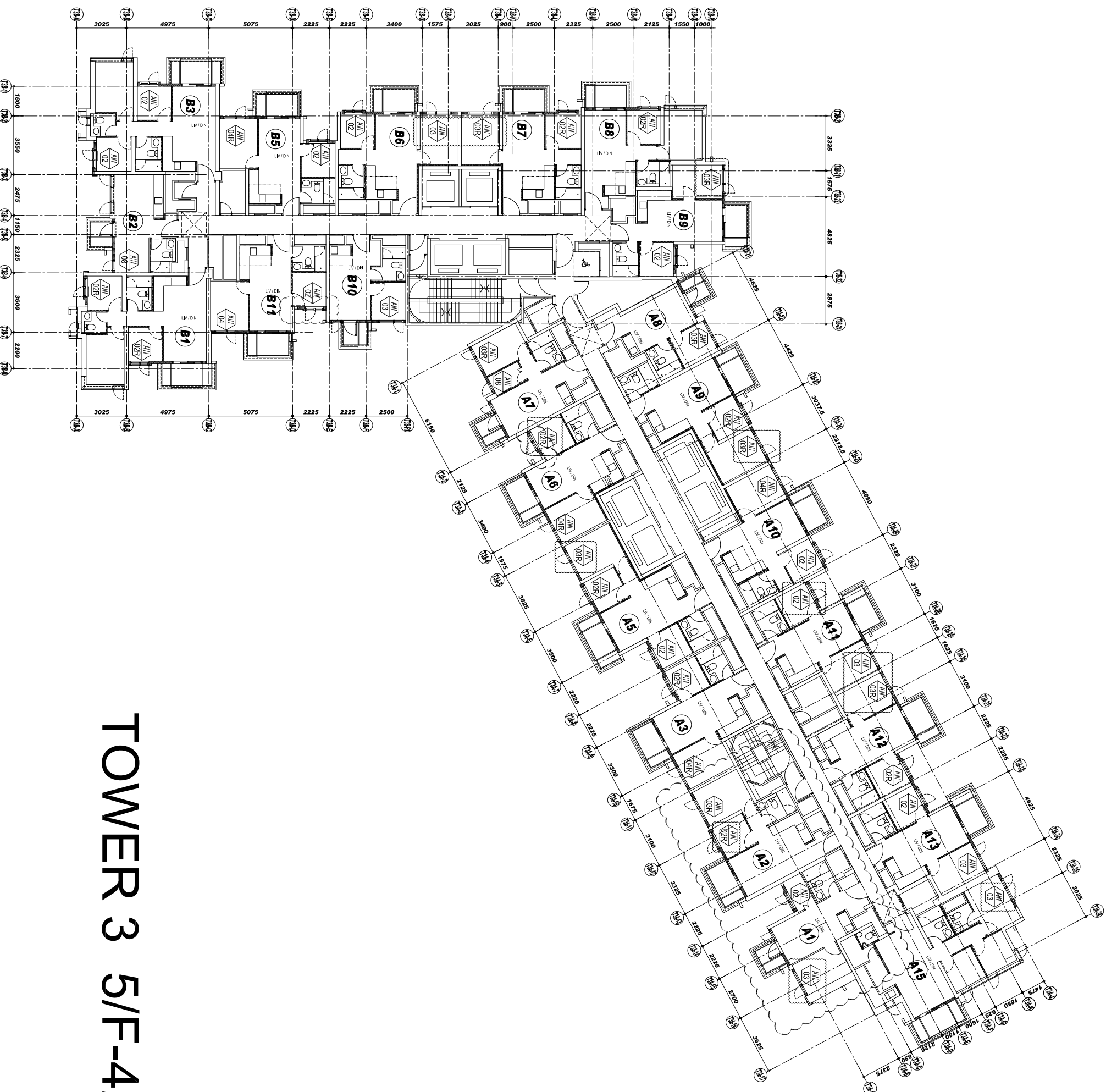

# TOWER 3 5/F-42/F

B.O. REF :

CLIENT :

**SUN HUNG KAI**  
REAL ESTATE AGENCY LTD.  
42/F SUN HUNG KAI CENTRE, WANGCHAI, HONGKONG

ARCHITECT :

**Iwk&partners**  
a r c h i t e c t s

MAIN CONTRACTOR :

**怡輝建築有限公司**  
Yee Fai Building Contractors Ltd.

STRUCTURAL ENGINEER :

**ARUP**

FAÇADE CONSULTANT:

**ALPHA CONSULTING LIMITED**  
Steel Structure & Façade Specialist

NOTE :

1. ALL DIMENSIONS ARE IN mm.
2. ALL ELEVATIONS ARE VIEWED FROM OUTSIDE.
3. ALL DIMENSIONS TO BE VERIFIED ON SITE BEFORE FABRICATION.

LEGEND :

- X1 --- DETAIL MARK NO.
- X001 --- REFER SHEET NO.

1. F.F.L.--FINISHED FLOOR LEVEL
2. S.F.L.--STRUCTURAL FLOOR LEVEL
3. (R) --REVERSED DETAIL

4. GLASS LEGEND

- EGL-1--8mmHS+12mm AIR GAP+10mmTP THK. I.G.U.
- EGL-2--10mm THK. CLEAR TEMPERED GLASS
- EGL-4--10mm THK. TEMPERED ACID ETCHED GLASS
- EGL-1A-8mmHS+12mm AIR GAP+8mmTP THK. I.G.U.

NO.	DATE	REVISION SUBJECT TO ARCH COMMENT	BY
E	14/12/2021	REVISION SUBJECT TO ARCH COMMENT	hvm
D	29/11/2021	REVISION SUBJECT TO ARCH COMMENT	hvm
C	02/11/2021	REVISION SUBJECT TO ARCH COMMENT	hvm
B	29/10/2021	REVISION SUBJECT TO ARCH COMMENT	hvm
A	18/10/2021	REVISION SUBJECT TO ARCH COMMENT	hvm

JOB NO. : J-856

PROJECT :

PROPOSED DEVELOPMENT ABOVE  
LIGHT RAIL TIN WING STOP TSWTL  
NO.23,AREA 33,TIN SHUI WAI, N.T.

TITLE :

WINDOW SCHEDULE FOR  
TOWER 3 ALUM. WINDOW

DATE : 02-Aug-21 SCALE : 1:40

DRAWN BY : ivon CHECKED BY :

**美特鋁質有限公司**  
MIDI ALUMINIUM FABRICATOR LTD.  
Units 6-8, Sunny Industrial Centre, 1/F  
610 Che Kwo Ling Road, Kowloon  
Tel:23489211-4 Fax:85227272666

DWG NO. : 856-SD-PW-5301 REV. : E

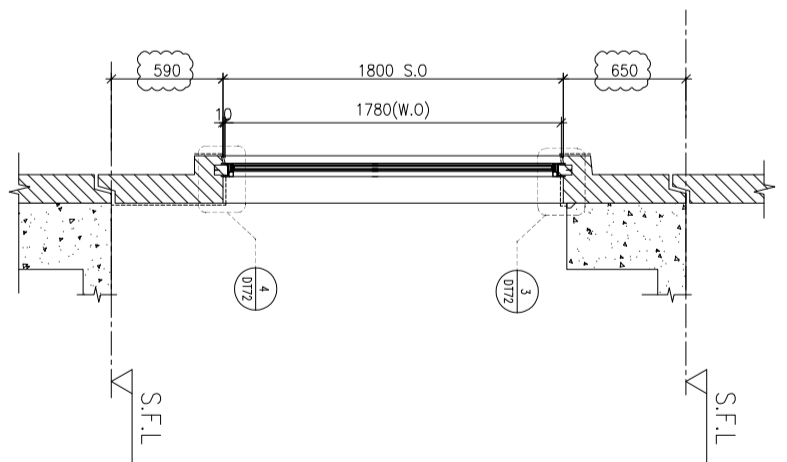
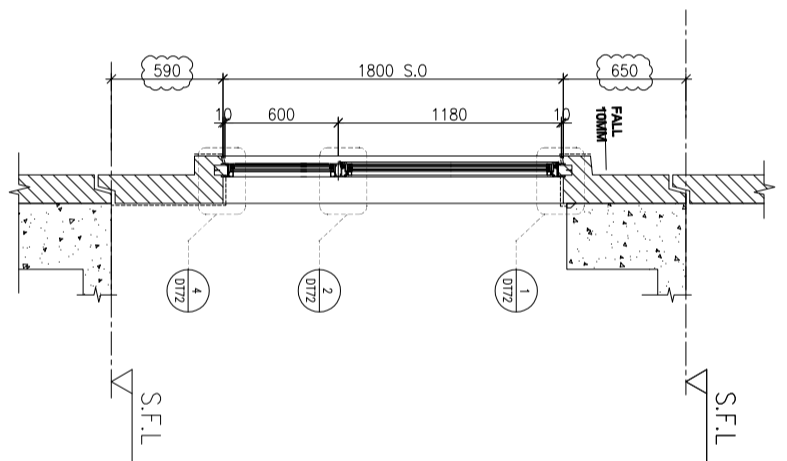
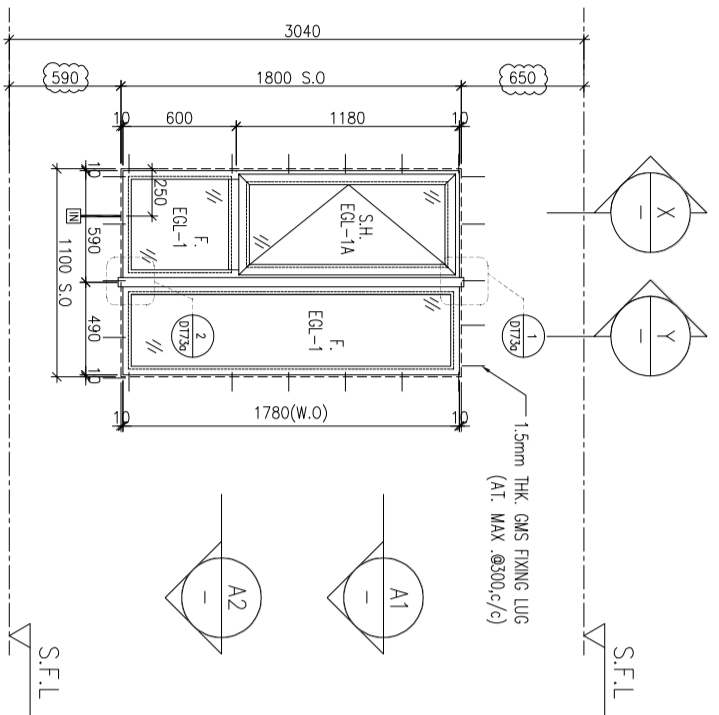

ELEVATION

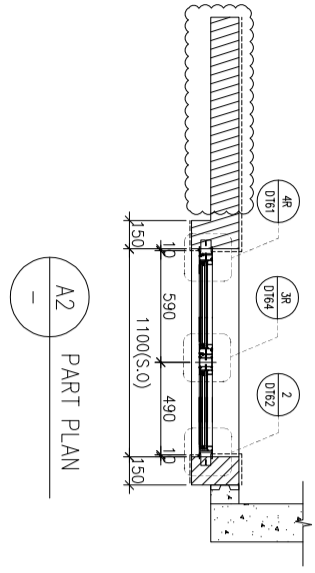
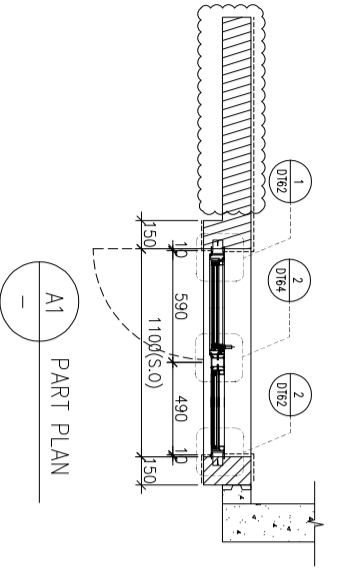

WINDOW MARK	AW 02
LOCATION	3/F~42/F(4/F,13/F,14/F,24/F,34/F OMITTED) UNIT B6
SECTION	70mm ALUM. SECTION
GLAZING	EGL-1,EGL-1A
QUANTITY	35 Nos.
REMARKS	FAÇADE(TYPE T3PF02 FOR 3/F~42/F)

WINDOW MARK	AW 02R
LOCATION	3/F~42/F(4/F,13/F,14/F,24/F,34/F OMITTED) UNIT A9,B7,B8
SECTION	70mm ALUM. SECTION
GLAZING	EGL-1,EGL-1A
QUANTITY	35 Nos / 35 Nos / 35 Nos
REMARKS	FAÇADE(TYPE T3PF02R FOR 3/F~42/F)

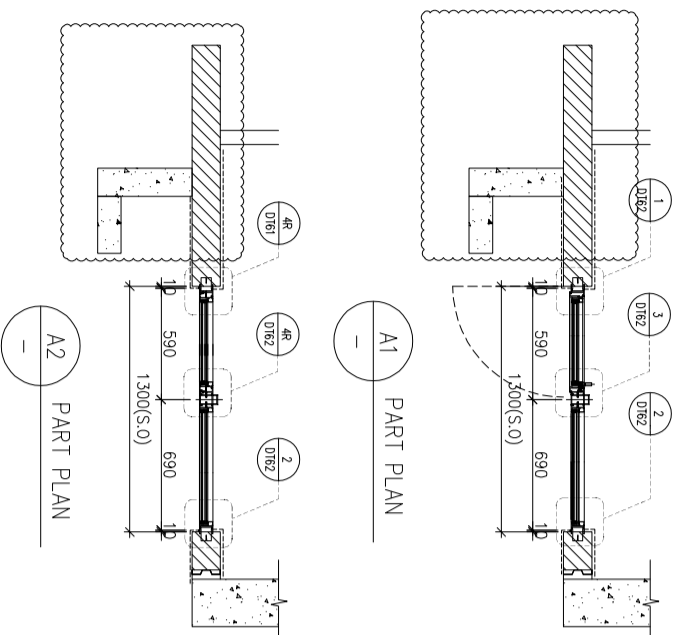
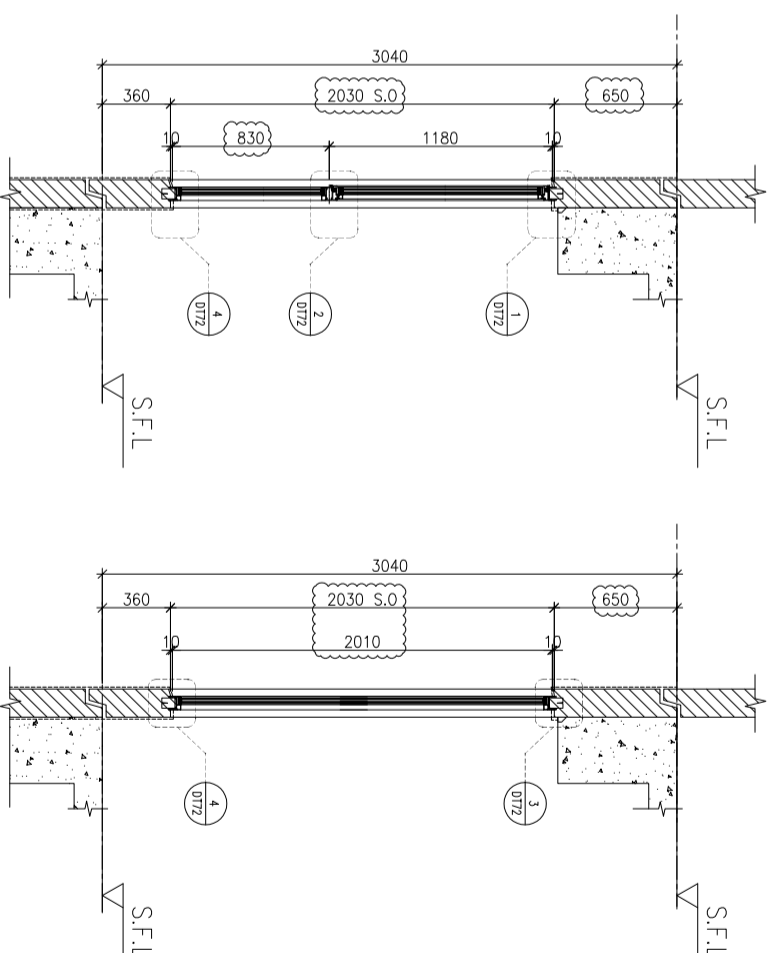
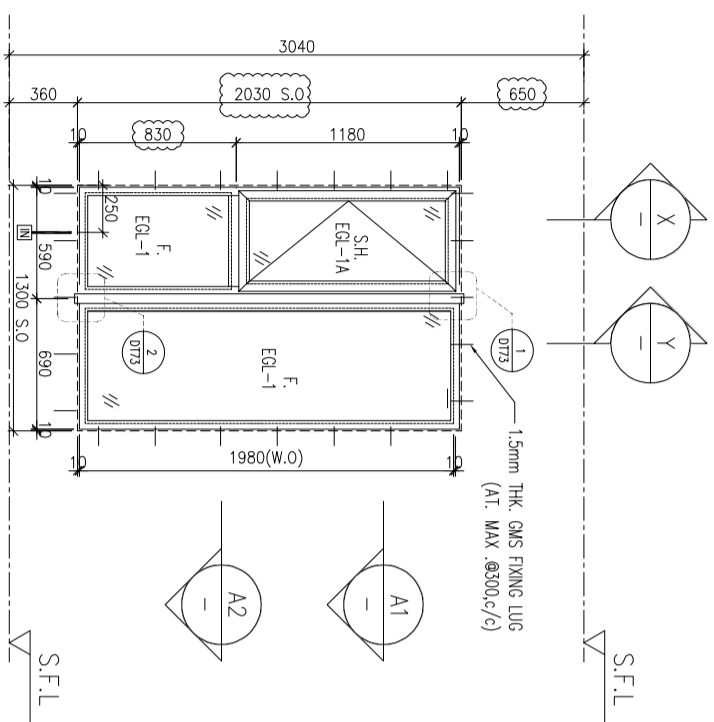

ELEVATION

WINDOW MARK	AW O4R
LOCATION	3/F~42/F(4/F,13/F,14/F,24/F,34/F OMITTED) UNIT A3,A6,A10,B5
SECTION	70mm ALUM. SECTION
GLAZING	EGL-1,EGL-1A
QUANTITY	35 Nos / 35 Nos / 35 Nos / 35 Nos
REMARKS	FACADE(TYPE T3PF04 FOR 3/F~42/F)

WINDOW MARK	AW O4
LOCATION	3/F~42/F(4/F,13/F,14/F,24/F,34/F OMITTED) UNIT B11
SECTION	70mm ALUM. SECTION
GLAZING	EGL-1,EGL-1A
QUANTITY	35 Nos
REMARKS	FACADE(TYPE T3PF04R FOR 3/F~42/F)

B.O. REF :

CLIENT :  
**SUN HUNG KAI**  
**REAL ESTATE AGENCY LTD.**  
 42/F SUN HUNG KAI CENTRE, WANCHAI, HONGKONG

ARCHITECT :  
**IWK&partners**  
 a r c h i t e c t s

MAIN CONTRACTOR :  
**怡輝建築有限公司**  
**Yee Fai Building Contractors Ltd.**

STRUCTURAL ENGINEER :  
**ARUP**

FACADE CONSULTANT:  
**ALPHA CONSULTING LIMITED**  
 Steel Structure & Facade Specialist

NOTE :  
 1. ALL DIMENSIONS ARE IN mm.  
 2. ALL ELEVATIONS ARE VIEWED FROM OUTSIDE.  
 3. ALL DIMENSIONS TO BE VERIFIED ON SITE BEFORE FABRICATION.

LEGEND :  
 X1 --- DETAIL MARK NO.  
 X001 --- REFER SHEET NO.

1. F.F.L.--FINISHED FLOOR LEVEL  
 2. S.F.L.--STRUCTURAL FLOOR LEVEL  
 3. (R) --REVERSED DETAIL

4. GLASS LEGEND  
 EGL-1--8mmHS+12mm AIR GAP+10mmTP THK. LG.U.  
 EGL-2--10mm THK. CLEAR TEMPERED GLASS  
 EGL-4--10mm THK. TEMPERED ACID ETCHED GLASS  
 EGL-1A-8mmHS+12mm AIR GAP+8mmTP THK. LG.U.

NO.	DATE	REVISION SUBJECT TO ARCH COMMENT	BY
F	14/12/2021	REVISION SUBJECT TO ARCH COMMENT	Wen
E	29/11/2021	REVISION SUBJECT TO ARCH COMMENT	Wen
D	02/11/2021	REVISION SUBJECT TO ARCH COMMENT	Wen
C	28/10/2021	REVISION SUBJECT TO ARCH COMMENT	Wen
B	18/10/2021	REVISION SUBJECT TO ARCH COMMENT	Wen
A	27/09/2021	REVISION SUBJECT TO ARCH COMMENT	Wen

JOB NO. : J-856

PROJECT :  
 PROPOSED DEVELOPMENT ABOVE  
 LIGHT RAIL TIN WING STOP TSWTL  
 NO.23,AREA 33,TIN SHUI WAI, N.T.

TITLE :  
 WINDOW SCHEDULE FOR  
 TOWER 3 ALUM. WINDOW

DATE : 02-Aug-21 SCALE : 1:40

DRAWN BY : Ivojn CHECKED BY :

**美特鋁質有限公司**  
**MIDI ALUMINIUM FABRICATOR LTD.**  
 Units 6-8, Sunny Industrial Centre, 1/F  
 610 Che Kwo Ling Road, Kowloon  
 Tel:23489211-4 Fax:85227272666

DWG NO. : 856-SD-PW-5302 REV. : F

B.O. REF :

CLIENT :

**SUN HUNG KAI**  
REAL ESTATE AGENCY LTD.  
42/F SUN HUNG KAI CENTRE, WANCHAI, HONGKONG

ARCHITECT :

**Iwk&partners**  
a r c h i t e c t s

MAIN CONTRACTOR :

**怡輝建築有限公司**  
Yee Fai Building Contractors Ltd.

STRUCTURAL ENGINEER :

**ARUP**

FAÇADE CONSULTANT:

**ALPHA CONSULTING LIMITED**  
Steel Structure & Façade Specialist

NOTE :

1. ALL DIMENSIONS ARE IN mm.
2. ALL ELEVATIONS ARE VIEWED FROM OUTSIDE.
3. ALL DIMENSIONS TO BE VERIFIED ON SITE BEFORE FABRICATION.

LEGEND :

X1 --- DETAIL MARK NO.  
X001 --- REFER SHEET NO.

1. F.F.L.--FINISHED FLOOR LEVEL
2. S.F.L.--STRUCTURAL FLOOR LEVEL
3. (R) --REVERSED DETAIL

4. GLASS LEGEND

EQ1-1--8mmHS+12mm AIR GAP+10mmTP THK. I.G.U.  
 EQ1-2--10mm THK. CLEAR TEMPERED GLASS  
 EQ1-4--10mm THK. TEMPERED ACID ETCHED GLASS  
 EQ1-1A-8mmHS+12mm AIR GAP+8mmTP THK. I.G.U.

NO.	DATE	REVISION SUBJECT TO ARCH COMMENT	BY
F	14/12/2021	REVISION SUBJECT TO ARCH COMMENT	NON
E	29/11/2021	REVISION SUBJECT TO ARCH COMMENT	NON
D	02/11/2021	REVISION SUBJECT TO ARCH COMMENT	NON
C	28/10/2021	REVISION SUBJECT TO ARCH COMMENT	NON
B	18/10/2021	REVISION SUBJECT TO ARCH COMMENT	NON
A	27/09/2021	REVISION SUBJECT TO ARCH COMMENT	NON

JOB NO. : J-856

PROJECT :

PROPOSED DEVELOPMENT ABOVE  
LIGHT RAIL TIN WING STOP TSWTL  
NO.23,AREA 33,TIN SHUI WAI, N.T.

TITLE :

WINDOW SCHEDULE FOR  
TOWER 3 ALUM. WINDOW

DATE : 02-Aug-21 SCALE : 1:40

DRAWN BY : Ivojn CHECKED BY :

**美特鋁質有限公司**  
MIDI ALUMINIUM FABRICATOR LTD.  
Units 6-8, Sunny Industrial Centre, 1/F  
610 Che Kwo Ling Road, Kowloon  
Tel:23489211-4 Fax:85227272666  
DWG NO. : 856-S0-PW-5303 REV. : F

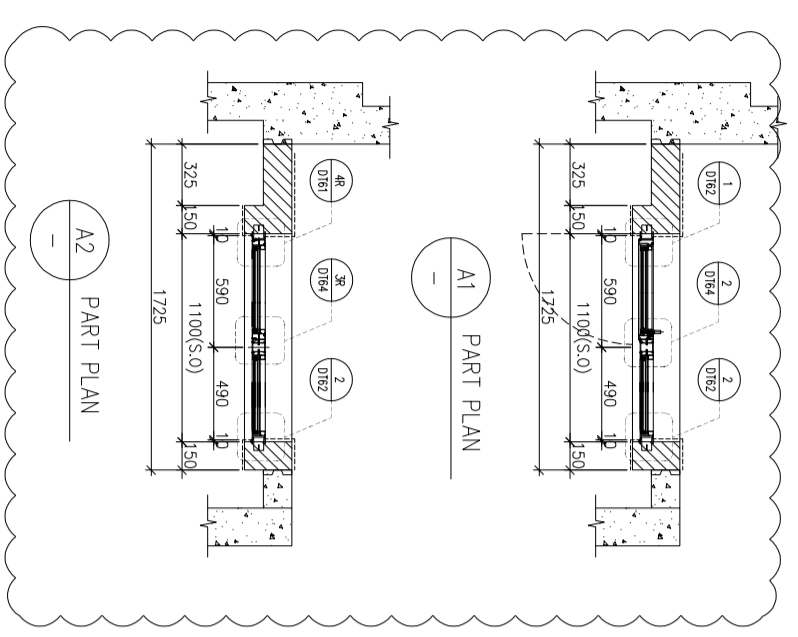
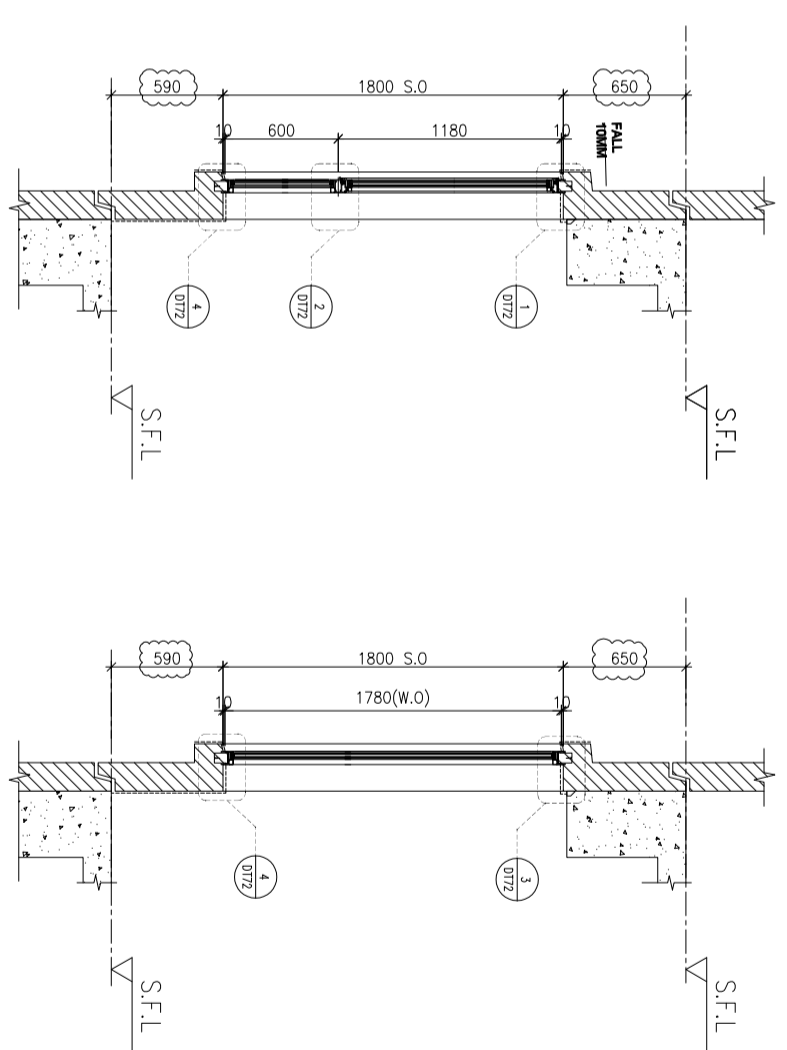
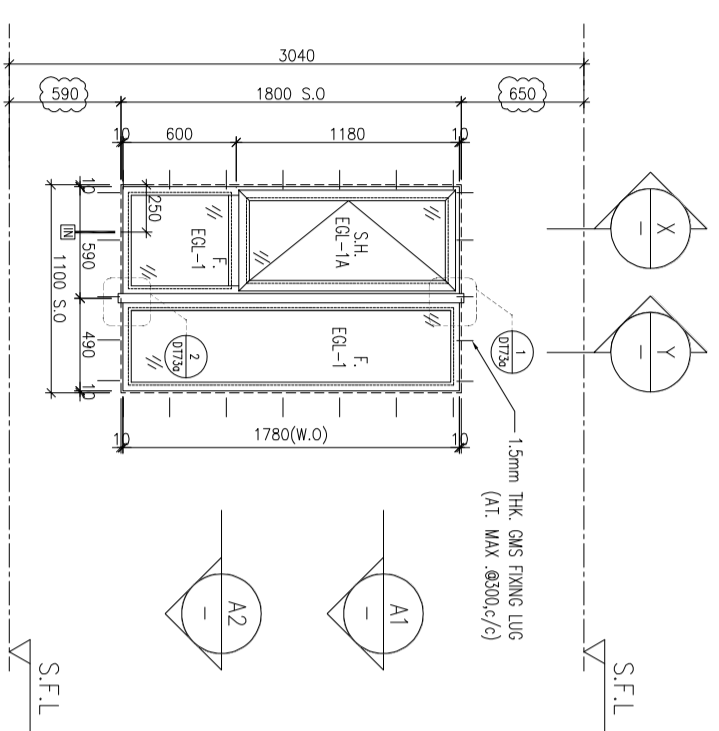

ELEVATION

WINDOW MARK	AW 02	AW 02R
LOCATION	3/F~42/F(4/F,13/F,14/F,24/F,34/F OMITTED) UNIT A10,A11,B3,B5,B9	3/F~42/F(4/F,13/F,14/F,24/F,34/F OMITTED) UNIT A6,B1,B11
SECTION	70mm ALUM. SECTION	70mm ALUM. SECTION
GLAZING	EGL-1,EGL-1A	EGL-1,EGL-1A
QUANTITY	35 Nos / 35 Nos / 35 Nos / 35 Nos / 35 Nos	35 Nos / 35 Nos / 35 Nos
REMARKS	FAÇADE(TYPE T3PF05R FOR 3/F~42/F)	FAÇADE(TYPE T3PF05 FOR 3/F~42/F)

B.O. REF :

CLIENT :

**SUN HUNG KAI**  
REAL ESTATE AGENCY LTD.  
42/F SUN HUNG KAI CENTRE, WANGCHAI, HONGKONG

ARCHITECT :

**IWK&partners**  
a r c h i t e c t s

MAIN CONTRACTOR :

**怡輝建築有限公司**  
Yee Fai Building Contractors Ltd.

STRUCTURAL ENGINEER :

**ARUP**

FAÇADE CONSULTANT:

**ALPHA CONSULTING LIMITED**  
Steel Structure & Façade Specialist

NOTE :

1. ALL DIMENSIONS ARE IN mm.
2. ALL ELEVATIONS ARE VIEWED FROM OUTSIDE.
3. ALL DIMENSIONS TO BE VERIFIED ON SITE BEFORE FABRICATION.

LEGEND :

X1 --- DETAIL MARK NO.  
X001 --- REFER SHEET NO.

1. F.F.L.--FINISHED FLOOR LEVEL
2. S.F.L.--STRUCTURAL FLOOR LEVEL
3. (R) --REVERSED DETAIL

4. GLASS LEGEND

EG1-1--8mmHS+12mm AIR GAP+10mmTP THK. I.G.U.  
 EG1-2--10mm THK. CLEAR TEMPERED GLASS  
 EG1-4--10mm THK. TEMPERED ACID ETCHED GLASS  
 EG1-1A-8mmHS+12mm AIR GAP+8mmTP THK. I.G.U.

NO.	DATE	REVISION SUBJECT TO ARCH COMMENT	BY
F	14/12/2021	REVISION SUBJECT TO ARCH COMMENT	hvn
E	29/11/2021	REVISION SUBJECT TO ARCH COMMENT	hvn
D	02/11/2021	REVISION SUBJECT TO ARCH COMMENT	hvn
C	28/10/2021	REVISION SUBJECT TO ARCH COMMENT	hvn
B	18/10/2021	REVISION SUBJECT TO ARCH COMMENT	hvn
A	27/09/2021	REVISION SUBJECT TO ARCH COMMENT	hvn

JOB NO. : J-856

PROJECT :

PROPOSED DEVELOPMENT ABOVE  
LIGHT RAIL TIN WING STOP TSWTL  
NO.23,AREA 33,TIN SHUI WAI, N.T.

TITLE :

WINDOW SCHEDULE FOR  
TOWER 3 ALUM. WINDOW

DATE : 02-Aug-21 SCALE : 1:40

DRAWN BY : ivon CHECKED BY :

**美特鋁質有限公司**  
MIDI ALUMINIUM FABRICATOR LTD.  
Units 6-8, Sunny Industrial Centre, 1/F  
610 Che Kwo Ling Road, Kowloon  
Tel:23489211-4 Fax:85227272666

DWG NO. : 856-S0-PW-5304 REV. : F

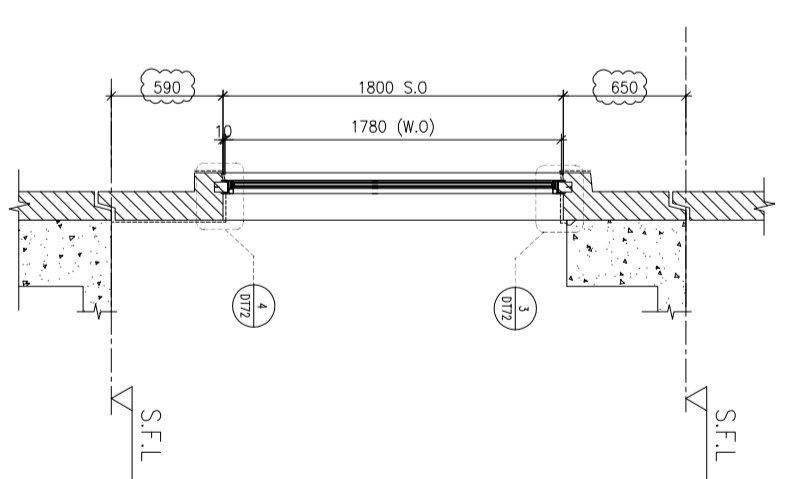
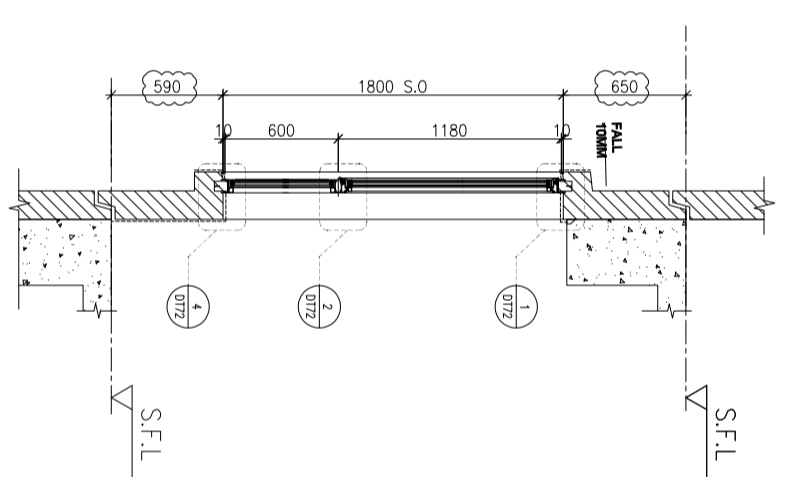
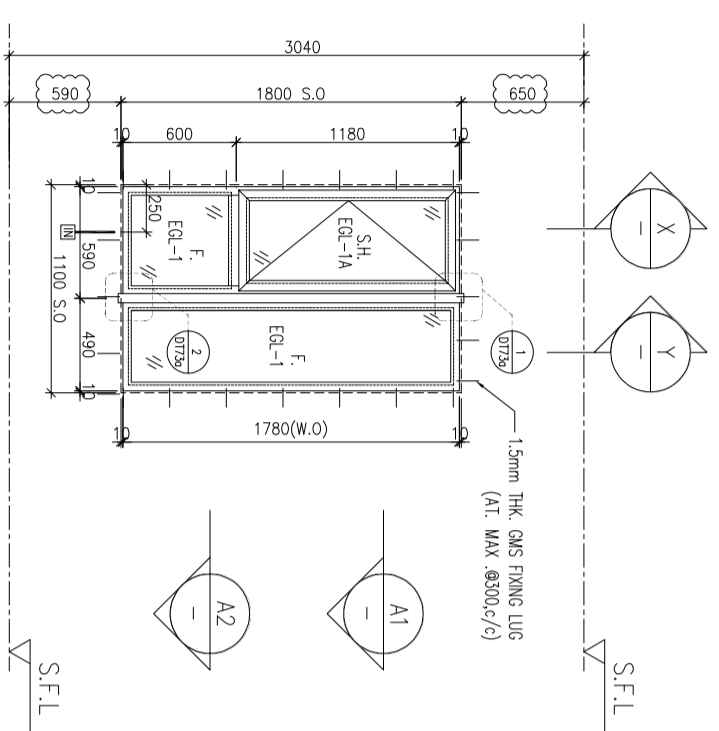

ELEVATION

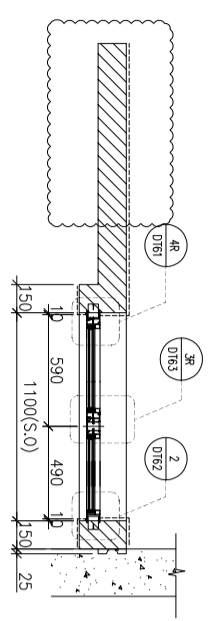
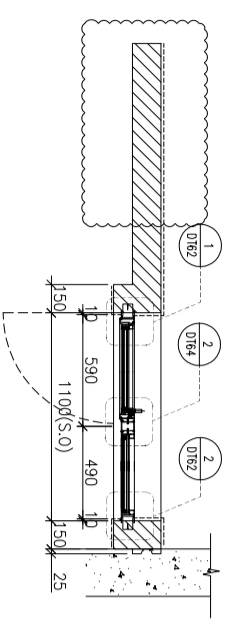

WINDOW MARK	AW 02
LOCATION	3/F~42/F(4/F,13/F,14/F,24/F,34/F OMITTED) UNIT B3
SECTION	70mm ALUM. SECTION
GLAZING	EGL-1,EGL-1A
QUANTITY	35 Nos
REMARKS	FAÇADE(TYPE T3PF08R FOR 3/F~42/F)

WINDOW MARK	AW 02R
LOCATION	3/F~42/F(4/F,13/F,14/F,24/F,34/F OMITTED) UNIT A2,A5,B1
SECTION	70mm ALUM. SECTION
GLAZING	EGL-1,EGL-1A
QUANTITY	35 Nos / 35 Nos / 35 Nos
REMARKS	FAÇADE(TYPE T3PF08R FOR 3/F~42/F)

B.O. REF :

CLIENT :

**SUN HUNG KAI**  
REAL ESTATE AGENCY LTD.  
42/F SUN HUNG KAI CENTRE, WANGCHAI, HONGKONG

ARCHITECT :

**Iwk&partners**  
a r c h i t e c t s

MAIN CONTRACTOR :

**怡輝建築有限公司**  
Yee Fai Building Contractors Ltd.

STRUCTURAL ENGINEER :

**ARUP**

FAÇADE CONSULTANT:

**ALPHA CONSULTING LIMITED**  
Steel Structure & Façade Specialist

NOTE :

1. ALL DIMENSIONS ARE IN mm.
2. ALL ELEVATIONS ARE VIEWED FROM OUTSIDE.
3. ALL DIMENSIONS TO BE VERIFIED ON SITE BEFORE FABRICATION.

LEGEND :

- (X1) --- DETAIL MARK NO.
- (X001) --- REFER SHEET NO.
- 1. F.F.L. -- FINISHED FLOOR LEVEL
- 2. S.F.L. -- STRUCTURAL FLOOR LEVEL
- 3. (R) -- REVERSED DETAIL
- 4. GLASS LEGEND

EG1-1 -- 8mmHS+12mm AIR GAP+10mmTP THK. I.G.U.  
 EG1-2 -- 10mm THK. CLEAR TEMPERED GLASS  
 EG1-4 -- 10mm THK. TEMPERED ACID ETCHED GLASS  
 EG1-1A -- 8mmHS+12mm AIR GAP+8mmTP THK. I.G.U.

NO.	DATE	REVISION SUBJECT TO ARCH COMMENT	BY
F	14/12/2021	REVISION SUBJECT TO ARCH COMMENT	Wen
E	29/11/2021	REVISION SUBJECT TO ARCH COMMENT	Wen
D	02/11/2021	REVISION SUBJECT TO ARCH COMMENT	Wen
C	28/10/2021	REVISION SUBJECT TO ARCH COMMENT	Wen
B	18/10/2021	REVISION SUBJECT TO ARCH COMMENT	Wen
A	27/09/2021	REVISION SUBJECT TO ARCH COMMENT	Wen

JOB NO. : J-856

PROJECT :

PROPOSED DEVELOPMENT ABOVE  
LIGHT RAIL TIN WING STOP TSWTL  
NO.23,AREA 33, TIN SHUI WAI, N.T.

TITLE : WINDOW SCHEDULE FOR  
TOWER 3 ALUM. WINDOW

DATE : 02-Aug-21 SCALE : 1:40  
DRAWN BY : IvoM CHECKED BY :

**美特鋁質有限公司**  
MIDI ALUMINIUM FABRICATOR LTD.  
Units 6-8, Sunny Industrial Centre, 1/F  
610 Che Kwo Ling Road, Kowloon  
Tel:23489211-4 Fax:85227272666  
DWG NO. : 856-SD-PW-5305 REV. : F

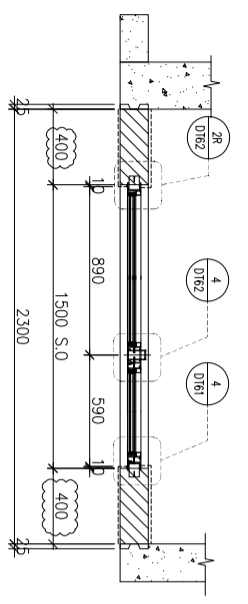
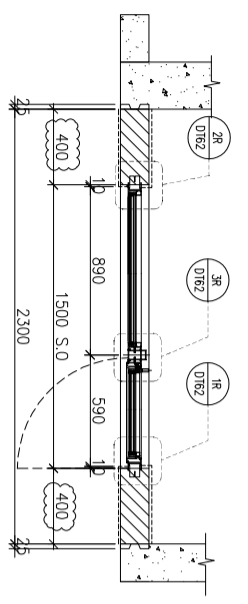
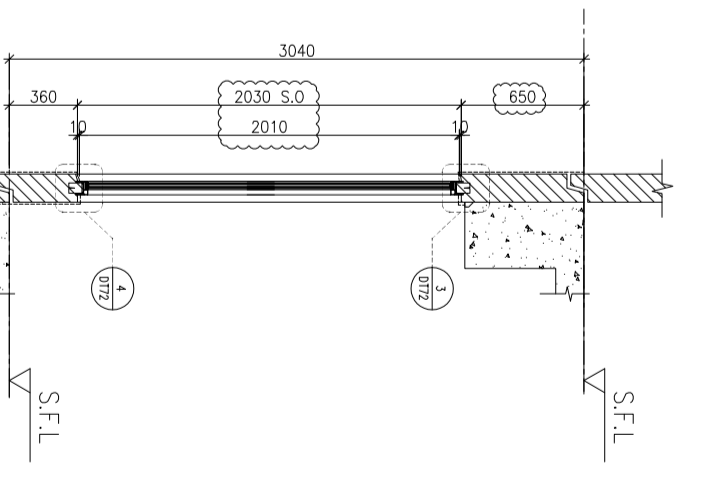
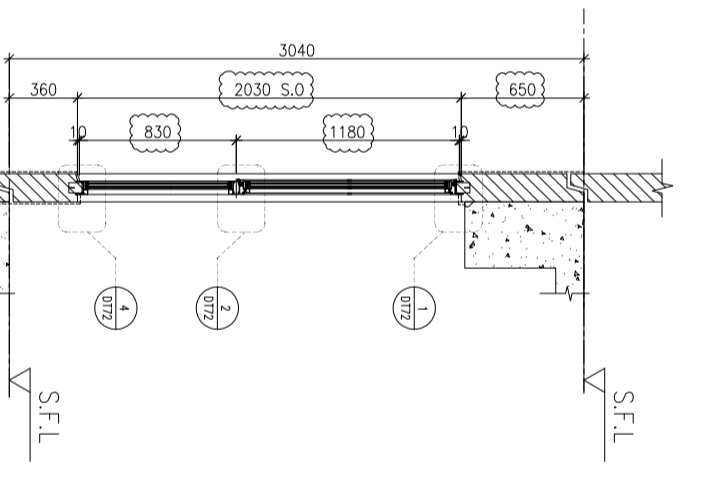
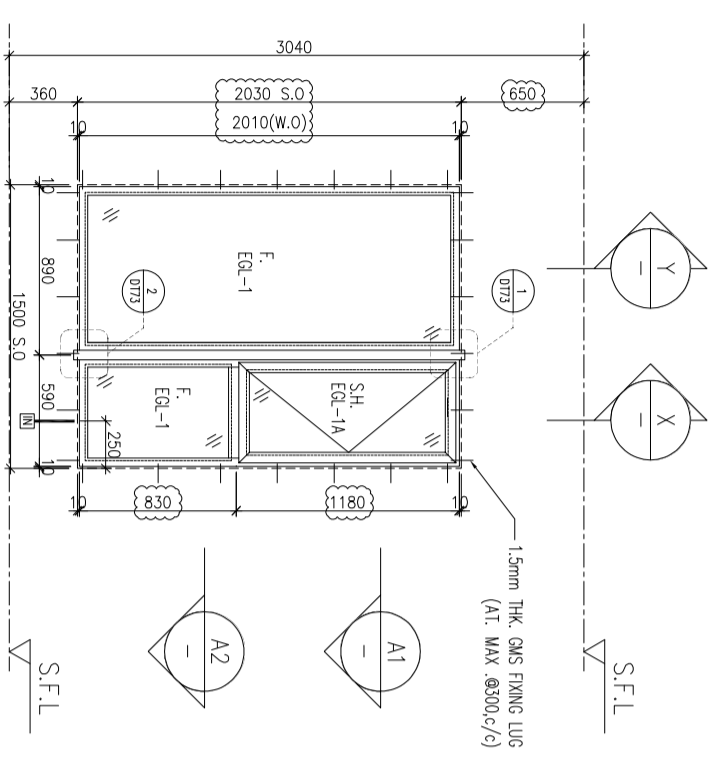

ELEVATION

WINDOW MARK	AW 03
LOCATION	3/F-42/F(4/F,13/F,14/F,24/F,34/F OMITTED) UNIT B6 & 5/F-42/F FOR A15
SECTION	70mm ALUM. SECTION
GLAZING	EGL-1,EGL-1A
QUANTITY	35 Nos / 34 Nos
REMARKS	FAÇADE(TYPE T3PF10 FOR 3/F~42/F)

WINDOW MARK	AW 03B
LOCATION	3/F-42/F(4/F,13/F,14/F,24/F,34/F OMITTED) UNIT A2,A5,A9,B7
SECTION	70mm ALUM. SECTION
GLAZING	EGL-1,EGL-1A
QUANTITY	35 Nos / 35 Nos / 35 Nos / 35 Nos
REMARKS	FAÇADE(TYPE T3PF10R FOR 3/F~42/F)

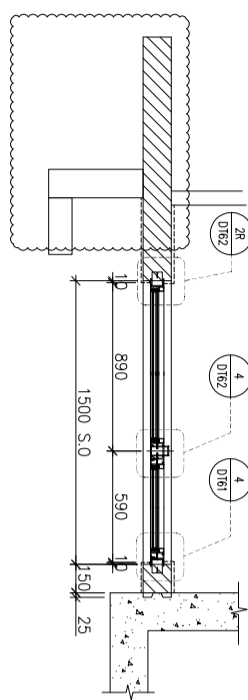
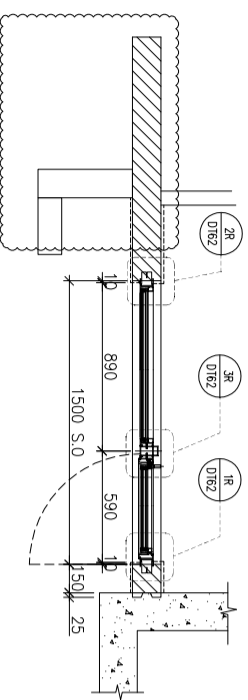
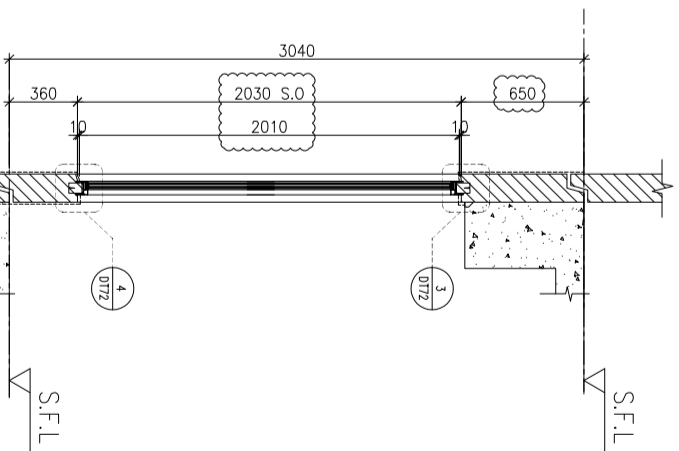
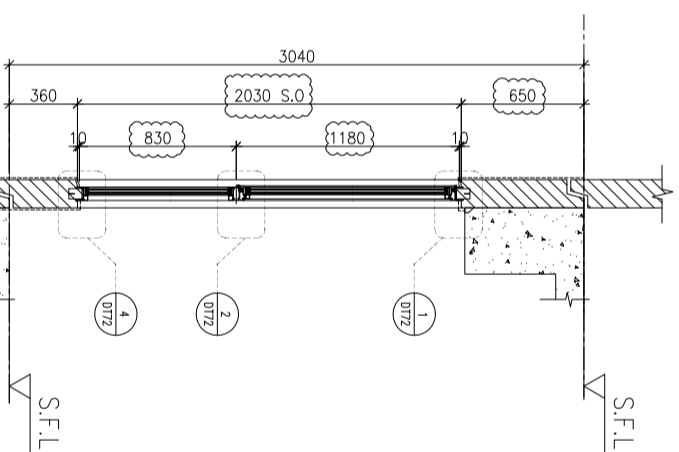
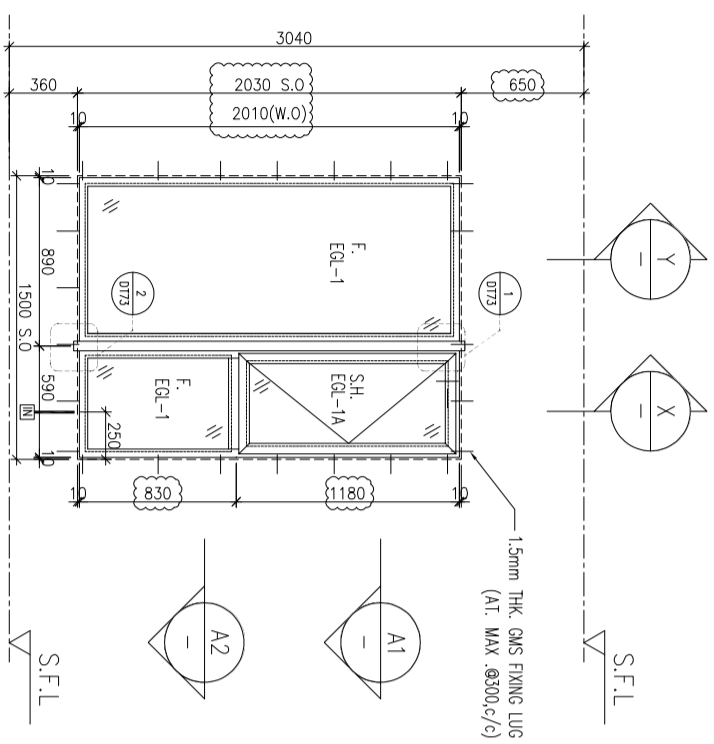

B.O. REF : \_\_\_\_\_

CLIENT : **SUN HUNG KAI**  
REAL ESTATE AGENCY LTD.  
42/F SUN HUNG KAI CENTRE, WANGCHAI, HONGKONG

ARCHITECT : **IWK&partners**  
a r c h i t e c t s

MAIN CONTRACTOR : **怡輝建築有限公司**  
Yee Fai Building Contractors Ltd.

STRUCTURAL ENGINEER : **ARUP**

FAÇADE CONSULTANT: **ALPHA CONSULTING LIMITED**  
Steel Structure & Façade Specialist

NOTE :  
1. ALL DIMENSIONS ARE IN mm.  
2. ALL ELEVATIONS ARE VIEWED FROM OUTSIDE.  
3. ALL DIMENSIONS TO BE VERIFIED ON SITE BEFORE FABRICATION.

LEGEND :  
X1 --- DETAIL MARK NO.  
X001 --- REFER SHEET NO.

1. F.F.L.--FINISHED FLOOR LEVEL  
2. S.F.L.--STRUCTURAL FLOOR LEVEL  
3. (R) --REVERSED DETAIL

4. GLASS LEGEND  
EQL-1--8mmHS+12mm AIR GAP+10mmTP THK. I.G.U.  
EQL-2--10mm THK. CLEAR TEMPERED GLASS  
EQL-4--10mm THK. TEMPERED ACID ETCHED GLASS  
EQL-1A-8mmHS+12mm AIR GAP+8mmTP THK. I.G.U.

NO.	DATE	REVISION	REVISION SUBJECT TO ARCH COMMENT
E	14/12/2021	REVISION SUBJECT TO ARCH COMMENT	None
D	29/11/2021	REVISION SUBJECT TO ARCH COMMENT	None
C	02/11/2021	REVISION SUBJECT TO ARCH COMMENT	None
B	29/10/2021	REVISION SUBJECT TO ARCH COMMENT	None
A	27/09/2021	REVISION SUBJECT TO ARCH COMMENT	None

JOB NO. : J-856

PROJECT : PROPOSED DEVELOPMENT ABOVE LIGHT RAIL TIN WING STOP TSWTL NO.23,AREA 33,TIN SHUI WAI, N.T.

TITLE : WINDOW SCHEDULE FOR TOWER 3 ALUM. WINDOW

DATE : 02-Aug-21 SCALE : 1:40

DRAWN BY : Ivorn CHECKED BY :

WINDOW MARK	AW 03
LOCATION	3/F~42/F(4/F,13/F,14/F,24/F,34/F OMITTED) UNIT B10
SECTION	70mm ALUM. SECTION
GLAZING	EGL-1,EGL-1A
QUANTITY	35 Nos
REMARKS	FAÇADE TYPE T3PF11R FOR 3/F~42/F

UNITED BUILDING SERVICES LIMITED  
MIDI ALUMINIUM FABRICATOR LTD.  
Units 6-8, Sunny Industrial Centre, 1/F  
610 Che Kwo Ling Road, Kowloon  
Tel:23489211-4 Fax:85227272666

DWG NO. : 856-SD-PW-5306 REV. : E

B.O. REF :

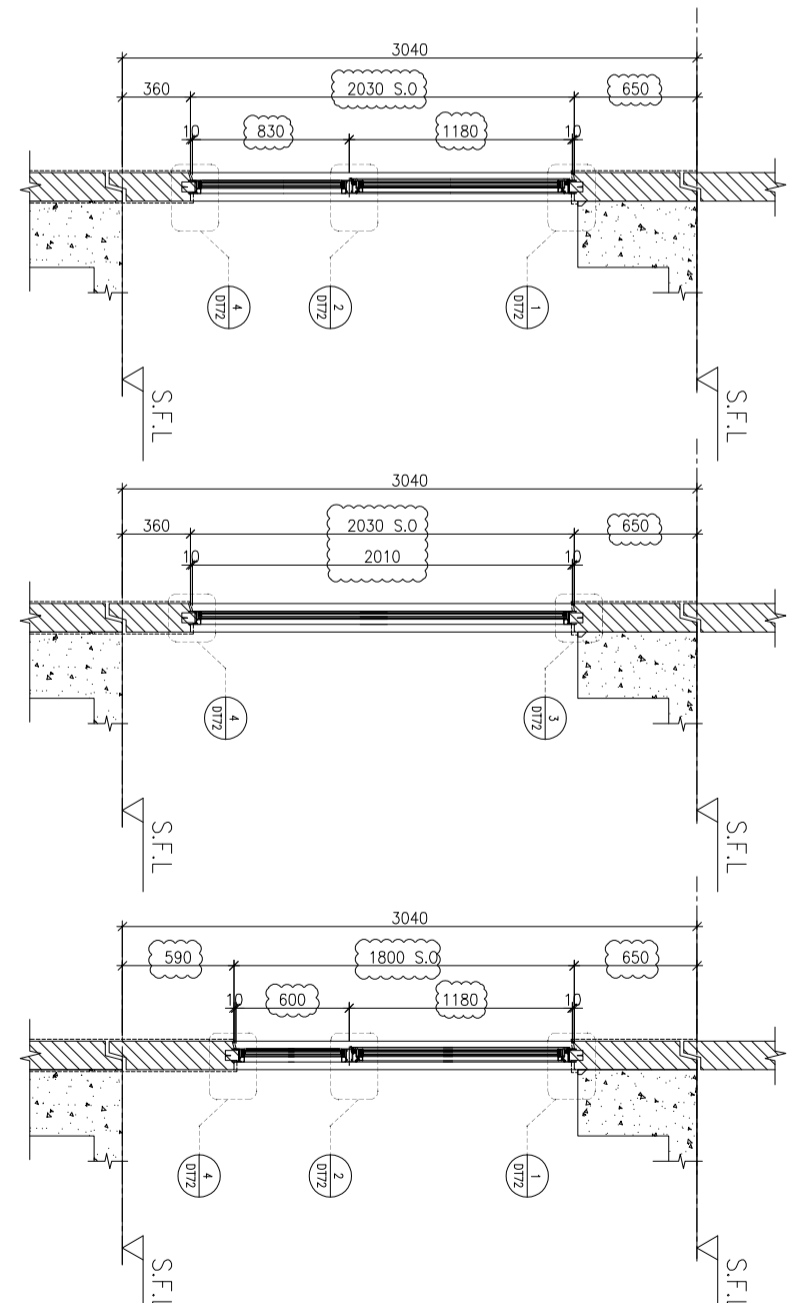
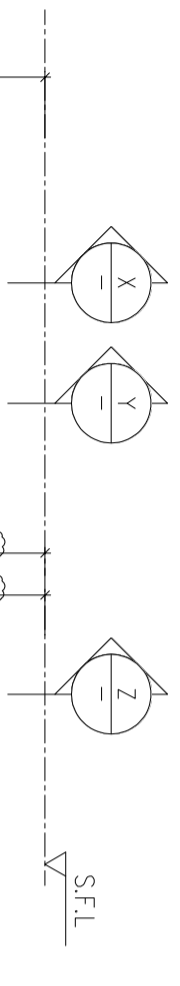

ELEVATION

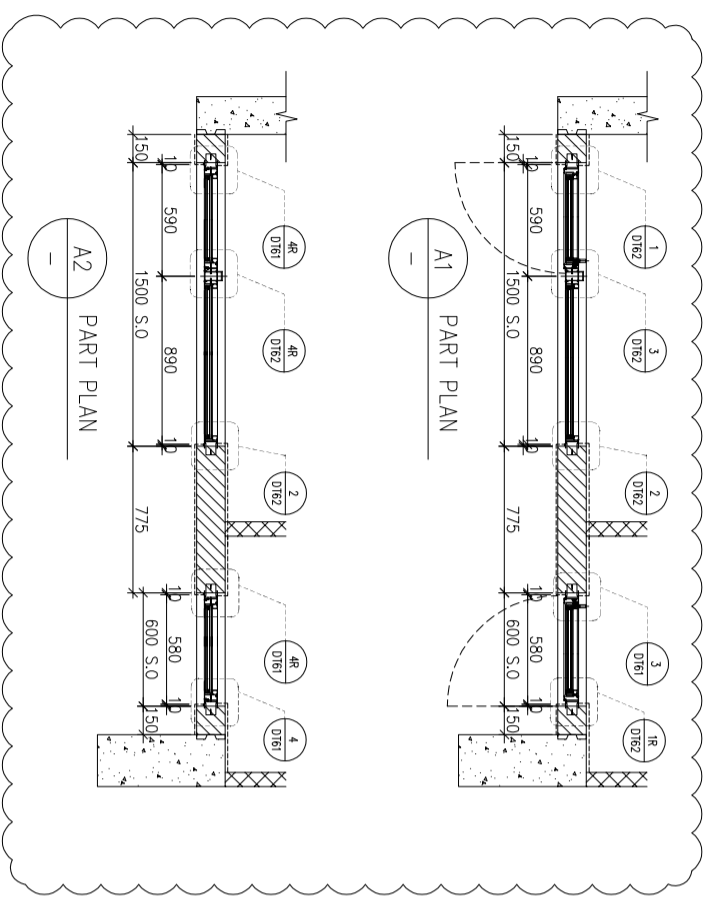

X PART SECTION

Y PART SECTION

Z PART SECTION

CLIENT : **SUN HUNG KAI**  
**REAL ESTATE AGENCY LTD.**  
 42/F SUN HUNG KAI CENTRE, WANCHAI, HONGKONG

ARCHITECT : **IWK&partners**  
 a r c h i t e c t s

MAIN CONTRACTOR : **怡輝建築有限公司**  
**Yee Fai Building Contractors Ltd.**

STRUCTURAL ENGINEER : **ARUP**

FAÇADE CONSULTANT : **ALPHA CONSULTING LIMITED**  
 Steel Structure & Façade Specialist

NOTE :

1. ALL DIMENSIONS ARE IN mm.
2. ALL ELEVATIONS ARE VIEWED FROM OUTSIDE.
3. ALL DIMENSIONS TO BE VERIFIED ON SITE BEFORE FABRICATION.

LEGEND :

X1 --- DETAIL MARK NO.  
 X001 --- REFER SHEET NO.

1. F.F.L.--FINISHED FLOOR LEVEL  
 2. S.F.L.--STRUCTURAL FLOOR LEVEL  
 3. (R) --REVERSED DETAIL

4. GLASS LEGEND

EQ1-1--8mmHS+12mm AIR GAP+10mmTP THK. I.G.U.  
 EQ1-2--10mm THK. CLEAR TEMPERED GLASS  
 EQ1-4--10mm THK. TEMPERED ACID ETCHED GLASS  
 EQ1-1A-8mmHS+12mm AIR GAP+8mmTP THK. I.G.U.

NO.	DATE	REVISION SUBJECT TO ARCH/COMMENT	BY
E	14/12/2021	REVISION SUBJECT TO ARCH/COMMENT	NON
D	29/11/2021	REVISION SUBJECT TO ARCH/COMMENT	NON
C	02/11/2021	REVISION SUBJECT TO ARCH/COMMENT	NON
B	28/10/2021	REVISION SUBJECT TO ARCH/COMMENT	NON
A	27/09/2021	REVISION SUBJECT TO ARCH/COMMENT	NON

JOB NO. :	J-856
PROJECT :	PROPOSED DEVELOPMENT ABOVE LIGHT RAIL TIN WING STOP TSWTL NO.23,AREA 33,TIN SHUI WAI, N.T.
TITLE :	WINDOW SCHEDULE FOR TOWER 3 ALUM. WINDOW
DATE :	02-Aug-21
SCALE :	1:40
DRAWN BY :	Ivorn
CHECKED BY :	
WINDOW MARK	AW 03R, AW 08
LOCATION	3/F-42/F,4/F,13/F,14/F,24/F,34/F OMITTED) UNIT A7
SECTION	70mm ALUM. SECTION
GLAZING	EGL-1,EGL-1A
QUANTITY	35 Nos
REMARKS	FAÇADE TYPE T3PF15 FOR 3/F~42/F)

**美特鋁質有限公司**  
**MIDI ALUMINIUM FABRICATOR LTD.**  
 Units 6-8, Sunny Industrial Centre, 1/F  
 610 Che Kwo Ling Road, Kowloon  
 Tel:23489211-4 Fax:85227272666  
 DWG NO. : 856-SD-PW-5307 REV. : E

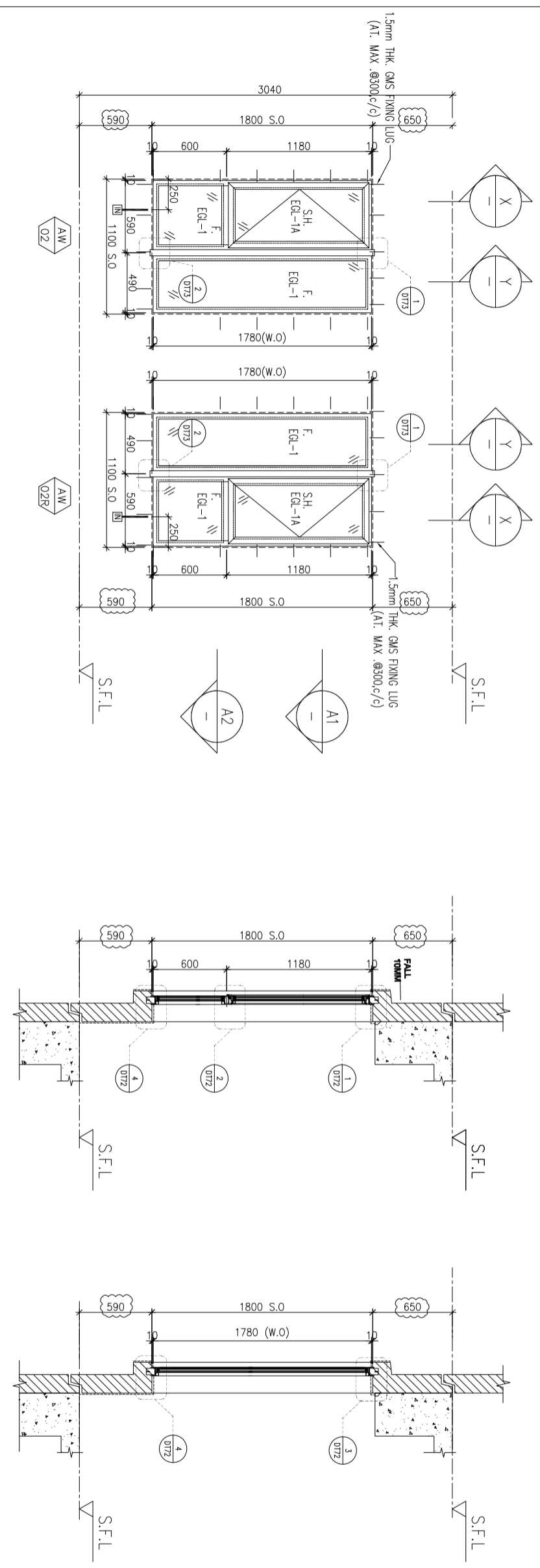

B.O. REF : \_\_\_\_\_

CLIENT : **SUN HUNG KAI**  
**REAL ESTATE AGENCY LTD.**  
 42/F SUN HUNG KAI CENTRE, WANGCHAI, HONGKONG

ARCHITECT : **IWK&partners**  
 a r c h i t e c t s

MAIN CONTRACTOR : **怡輝建築有限公司**  
**Yee Fai Building Contractors Ltd.**

STRUCTURAL ENGINEER : **ARUP**

FAÇADE CONSULTANT : **ALPHA CONSULTING LIMITED**  
 Steel Structure & Façade Specialist

NOTE :  
 1. ALL DIMENSIONS ARE IN mm.  
 2. ALL ELEVATIONS ARE VIEWED FROM OUTSIDE.  
 3. ALL DIMENSIONS TO BE VERIFIED ON SITE BEFORE FABRICATION.

LEGEND :  
 X1 --- DETAIL MARK NO.  
 X001 --- REFER SHEET NO.

1. F.F.L.--FINISHED FLOOR LEVEL  
 2. S.F.L.--STRUCTURAL FLOOR LEVEL  
 3. (R) --REVERSED DETAIL

4. GLASS LEGEND  
 EGL-1--8mmHS+12mm AIR GAP+10mmTP THK. I.G.U.  
 EGL-2--10mm THK. CLEAR TEMPERED GLASS  
 EGL-4--10mm THK. TEMPERED ACID ETCHED GLASS  
 EGL-1A-8mmHS+12mm AIR GAP+8mmTP THK. I.G.U.

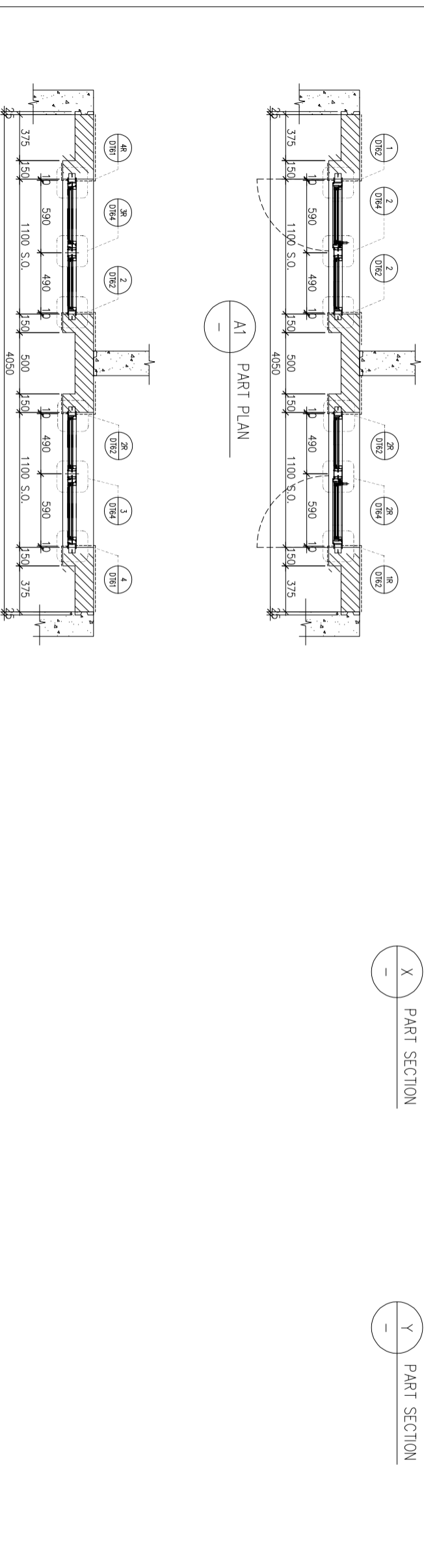

JOB NO. : J-856

PROJECT : PROPOSED DEVELOPMENT ABOVE LIGHT RAIL TIN WING STOP TSWTL NO.23,AREA 33,TIN SHUI WAI, N.T.

TITLE : WINDOW SCHEDULE FOR TOWER 3 ALUM. WINDOW

DATE : 02-Aug-21 SCALE : 1:40

DRAWN BY : IvoM CHECKED BY :

NO.	DATE	REVISION	REVISION SUBJECT TO ARCH COMMENT
F	14/12/2021	REVISION SUBJECT TO ARCH COMMENT	NON
E	29/11/2021	REVISION SUBJECT TO ARCH COMMENT	NON
D	02/11/2021	REVISION SUBJECT TO ARCH COMMENT	NON
C	28/10/2021	REVISION SUBJECT TO ARCH COMMENT	NON
B	18/10/2021	REVISION SUBJECT TO ARCH COMMENT	NON
A	27/09/2021	REVISION SUBJECT TO ARCH COMMENT	NON

WINDOW MARK	AW 02	AW 02R
LOCATION	3/F~42/F/4/F.13/F.14/F.24/F.34/F OMITTED) UNIT A3&A5, A12&A13	
SECTION	70mm ALUM. SECTION	
GLAZING	EGL-1,EGL-1A	
QUANTITY	35 Nos / 35 Nos	
REMARKS	FAÇADETYPE T3PF16 FOR 3/F~42/F)	

DRWING NO. : 0856-SD-PW-5308 REV. : F

DATE : 02-Aug-21 SCALE : 1:40

DRAWN BY : IvoM CHECKED BY :

PROJECT : PROPOSED DEVELOPMENT ABOVE LIGHT RAIL TIN WING STOP TSWTL NO.23,AREA 33,TIN SHUI WAI, N.T.

TITLE : WINDOW SCHEDULE FOR TOWER 3 ALUM. WINDOW

JOB NO. : J-856

ARCHITECT : **IWK&partners**  
 a r c h i t e c t s

MAIN CONTRACTOR : **怡輝建築有限公司**  
**Yee Fai Building Contractors Ltd.**

STRUCTURAL ENGINEER : **ARUP**

FAÇADE CONSULTANT : **ALPHA CONSULTING LIMITED**  
 Steel Structure & Façade Specialist

NOTE :  
 1. ALL DIMENSIONS ARE IN mm.  
 2. ALL ELEVATIONS ARE VIEWED FROM OUTSIDE.  
 3. ALL DIMENSIONS TO BE VERIFIED ON SITE BEFORE FABRICATION.

LEGEND :  
 X1 --- DETAIL MARK NO.  
 X001 --- REFER SHEET NO.

1. F.F.L.--FINISHED FLOOR LEVEL  
 2. S.F.L.--STRUCTURAL FLOOR LEVEL  
 3. (R) --REVERSED DETAIL

4. GLASS LEGEND  
 EGL-1--8mmHS+12mm AIR GAP+10mmTP THK. I.G.U.  
 EGL-2--10mm THK. CLEAR TEMPERED GLASS  
 EGL-4--10mm THK. TEMPERED ACID ETCHED GLASS  
 EGL-1A-8mmHS+12mm AIR GAP+8mmTP THK. I.G.U.

B.O. REF :

CLIENT :

**SUN HUNG KAI**  
REAL ESTATE AGENCY LTD.  
42/F SUN HUNG KAI CENTRE, WANCHAI, HONGKONG

ARCHITECT :

**IWK&partners**  
a r c h i t e c t s

MAIN CONTRACTOR :

怡輝建築有限公司  
**Yee Fai Building Contractors Ltd.**

STRUCTURAL ENGINEER :

**ARUP**

FAÇADE CONSULTANT:

**ALPHA CONSULTING LIMITED**  
Steel Structure & Façade Specialist

NOTE :

1. ALL DIMENSIONS ARE IN mm.
2. ALL ELEVATIONS ARE VIEWED FROM OUTSIDE.
3. ALL DIMENSIONS TO BE VERIFIED ON SITE BEFORE FABRICATION.

LEGEND :

(X1) --- DETAIL MARK NO.  
(X001) --- REFER SHEET NO.

1. F.F.L.--FINISHED FLOOR LEVEL
2. S.F.L.--STRUCTURAL FLOOR LEVEL
3. (R) --REVERSED DETAIL

4. GLASS LEGEND

EQI-1--8mmHS+12mm AIR GAP+10mmTP THK. I.G.U.  
EQI-2--10mm THK. CLEAR TEMPERED GLASS  
EQI-4--10mm THK. TEMPERED ACID ETCHED GLASS  
EQI-1A-8mmHS+12mm AIR GAP+8mmTP THK. I.G.U.

NO.	DATE	REVISION SUBJECT TO ARCH COMMENT	BY
F	14/12/2021	REVISION SUBJECT TO ARCH COMMENT	hvn
E	29/11/2021	REVISION SUBJECT TO ARCH COMMENT	hvn
D	02/11/2021	REVISION SUBJECT TO ARCH COMMENT	hvn
C	28/10/2021	REVISION SUBJECT TO ARCH COMMENT	hvn
B	18/10/2021	REVISION SUBJECT TO ARCH COMMENT	hvn
A	27/09/2021	REVISION SUBJECT TO ARCH COMMENT	hvn

JOB NO. : J-856

PROJECT :

PROPOSED DEVELOPMENT ABOVE  
LIGHT RAIL TIN WING STOP TSWTL  
NO.23,AREA 33,TIN SHUI WAI, N.T.

TITLE :

WINDOW SCHEDULE FOR  
TOWER 3 ALUM. WINDOW

DATE : 02-Aug-21 SCALE : 1:40

DRAWN BY : lvon CHECKED BY :

**美特鋁質有限公司**  
MIDI ALUMINIUM FABRICATOR LTD.  
Units 6-8, Sunny Industrial Centre, 1/F  
610 Che Kwo Ling Road, Kowloon  
Tel:23489211-4 Fax:95212727666

DWG NO. : 856-SD-PW-5309 REV. : F

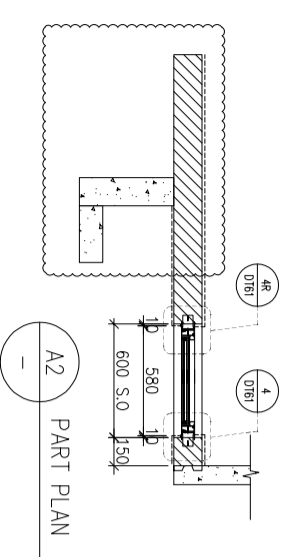
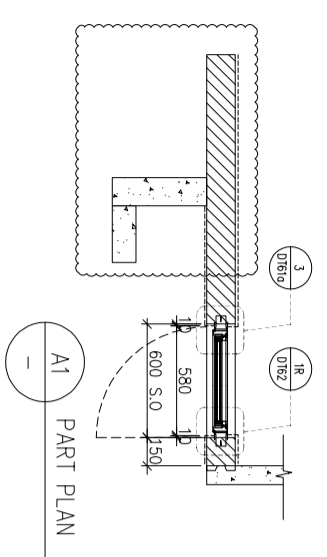
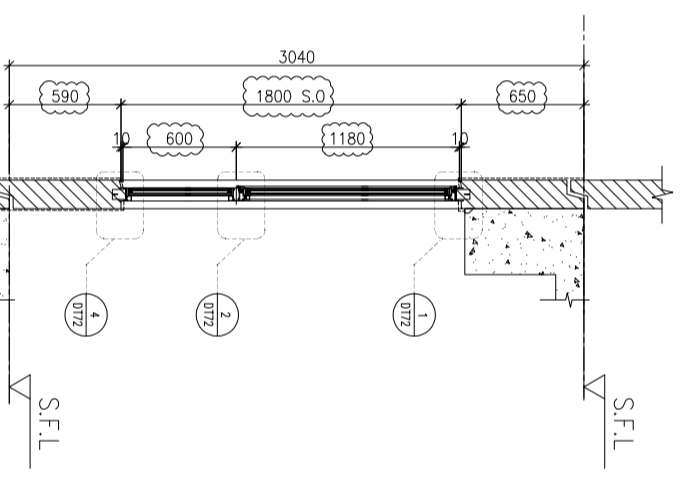
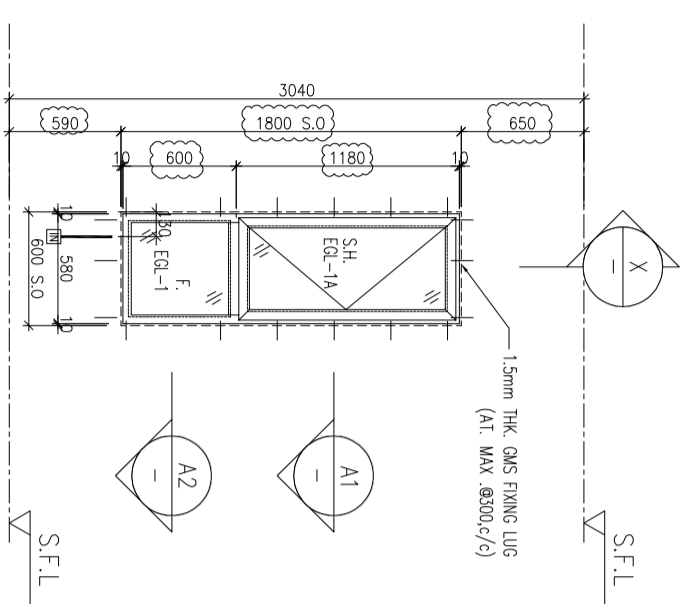

ELEVATION

WINDOW MARK



LOCATION

3/F~42/F/4/F.13/F.14/F.24/F.34/F OMITTED) UNIT B2

SECTION

70mm ALUM. SECTION

GLAZING

EGL-1,EGL-1A

QUANTITY

35 Nos

REMARKS

FAÇADE TYPE T3PF18 FOR 3/F~42/F)

B.O. REF :

CLIENT :

**SUN HUNG KAI**  
REAL ESTATE AGENCY LTD.  
42/F SUN HUNG KAI CENTRE, WANCHAI, HONGKONG

ARCHITECT :

**IWK&partners**  
a r c h i t e c t s

MAIN CONTRACTOR :

**怡輝建築有限公司**  
Yee Fai Building Contractors Ltd.

STRUCTURAL ENGINEER :

**ARUP**

FAÇADE CONSULTANT:

**ALPHA CONSULTING LIMITED**  
Steel Structure & Façade Specialist

NOTE :

1. ALL DIMENSIONS ARE IN mm.
2. ALL ELEVATIONS ARE VIEWED FROM OUTSIDE.
3. ALL DIMENSIONS TO BE VERIFIED ON SITE BEFORE FABRICATION.

LEGEND :

- X1 --- DETAIL MARK NO.
- X001 --- REFER SHEET NO.
- 1. F.F.L. -- FINISHED FLOOR LEVEL
- 2. S.F.L. -- STRUCTURAL FLOOR LEVEL
- 3. (R) -- REVERSED DETAIL
- 4. GLASS LEGEND

EGL-1 -- 8mmHS+12mm AIR GAP+10mmTP THK. I.G.U.  
 EGL-2 -- 10mm THK. CLEAR TEMPERED GLASS  
 EGL-4 -- 10mm THK. TEMPERED ACID ETCHED GLASS  
 EGL-1A -- 8mmHS+12mm AIR GAP+8mmTP THK. I.G.U.

NO.	DATE	REVISION
D	14/12/2021	REVISION SUBJECT TO ARCH COMMENT Ivm
C	29/11/2021	REVISION SUBJECT TO ARCH COMMENT Ivm
B	18/10/2021	REVISION SUBJECT TO ARCH COMMENT Ivm
A	12/10/2021	REVISION SUBJECT TO ARCH COMMENT Ivm

JOB NO. : J-856

PROJECT :

PROPOSED DEVELOPMENT ABOVE  
LIGHT RAIL TIN WING STOP TSWTL  
NO.23, AREA 33, TIN SHUI WAI, N.T.

TITLE :

WINDOW SCHEDULE FOR  
TOWER 3 ALUM. WINDOW

DATE : 02-Aug-21 SCALE : 1:40

DRAWN BY : Ivmn CHECKED BY :

**美特鋁質有限公司**  
MIDI ALUMINIUM FABRICATOR LTD.  
Units 6-8, Sunny Industrial Centre, 1/F  
610 Che Kwo Ling Road, Kowloon  
Tel: 23489211-4 Fax: (852) 27272666

DWG NO. : 856-SD-PW-5310 REV. : D

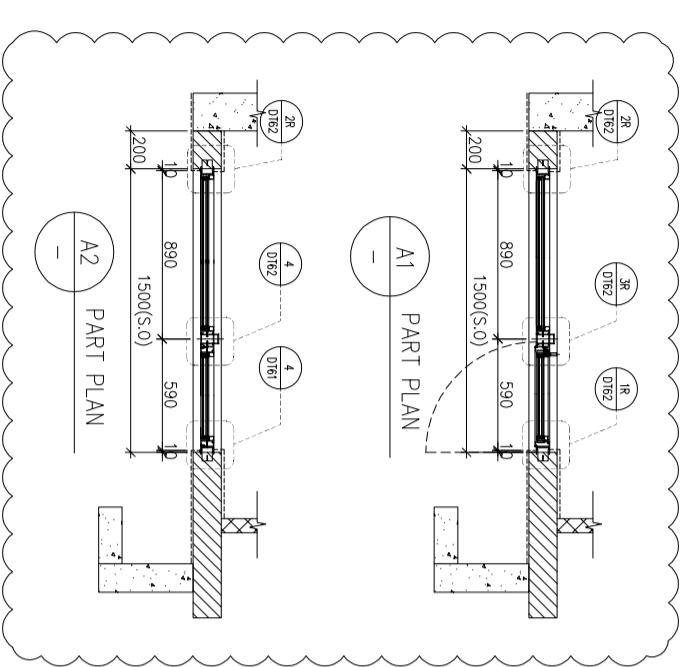
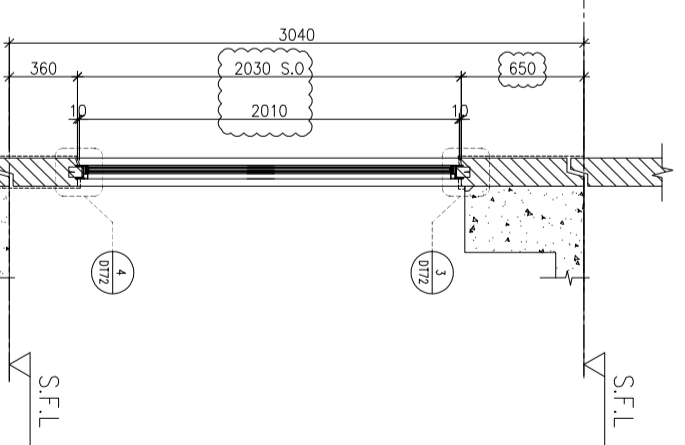
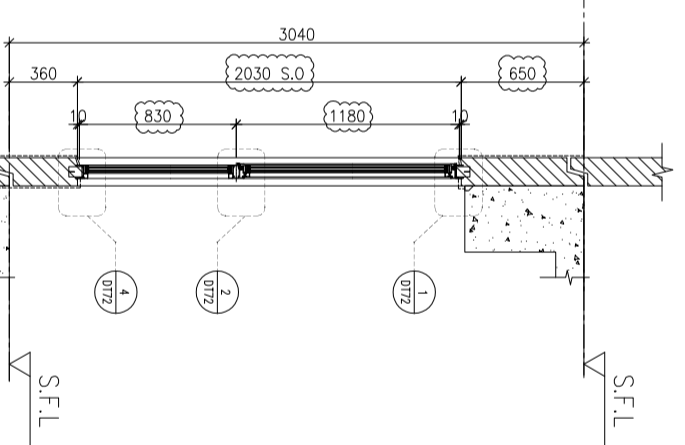
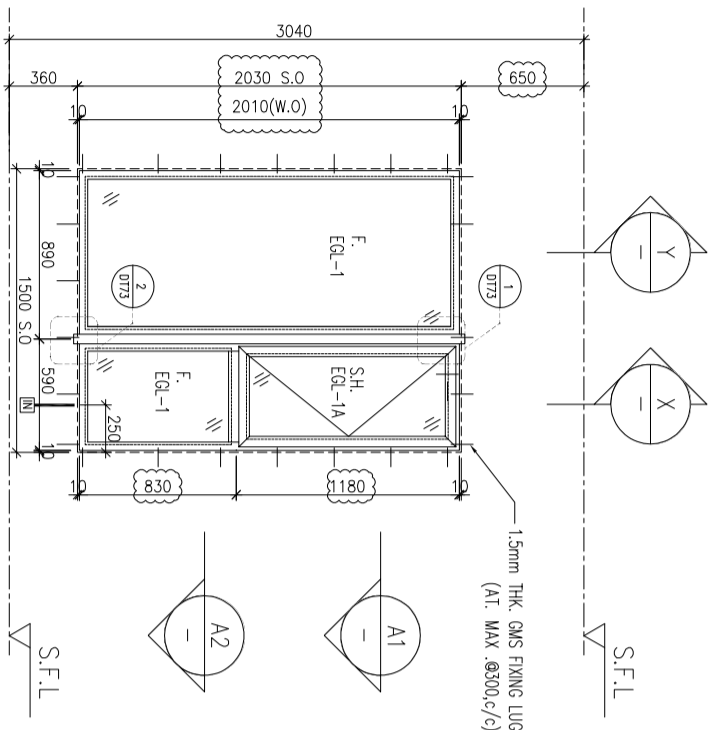

ELEVATION

WINDOW MARK	AW 03
LOCATION	3/F~42/F(4/F,13/F,14/F,24/F,34/F OMITTED) UNIT A11,A13
SECTION	70mm ALUM. SECTION
GLAZING	EGL-1,EGL-1A
QUANTITY	35 Nos
REMARKS	FAÇADE(TYPE T3PF04 FOR 3/F~42/F)

WINDOW MARK	AW 03B
LOCATION	3/F~42/F(4/F,13/F,14/F,24/F,34/F OMITTED) UNIT A12 ,B9
SECTION	70mm ALUM. SECTION
GLAZING	EGL-1,EGL-1A
QUANTITY	35 Nos/35 Nos
REMARKS	FAÇADE(TYPE T3PF04R FOR 3/F~42/F)

B.O. REF :

CLIENT :

**SUN HUNG KAI**  
REAL ESTATE AGENCY LTD.  
42/F SUN HUNG KAI CENTRE, WANGCHAI, HONGKONG

ARCHITECT :

**IWK&partners**  
a r c h i t e c t s

MAIN CONTRACTOR :

**怡輝建築有限公司**  
Yee Fai Building Contractors Ltd.

STRUCTURAL ENGINEER :

**ARUP**

FAÇADE CONSULTANT:

**ALPHA CONSULTING LIMITED**  
Steel Structure & Façade Specialist

NOTE :

1. ALL DIMENSIONS ARE IN mm.
2. ALL ELEVATIONS ARE VIEWED FROM OUTSIDE.
3. ALL DIMENSIONS TO BE VERIFIED ON SITE BEFORE FABRICATION.

LEGEND :

- X1 --- DETAIL MARK NO.
- X001 --- REFER SHEET NO.

1. F.F.L. -- FINISHED FLOOR LEVEL
2. S.F.L. -- STRUCTURAL FLOOR LEVEL
3. (R) -- REVERSED DETAIL

4. GLASS LEGEND

- EQI-1 -- 8mmHS+12mm AIR GAP+10mmTP THK. I.G.U.
- EQI-2 -- 10mm THK. CLEAR TEMPERED GLASS
- EQI-4 -- 10mm THK. TEMPERED ACID ETCHED GLASS
- EQI-1A -- 8mmHS+12mm AIR GAP+8mmTP THK. I.G.U.

NO.	DATE	REVISION
C	14/12/2021	REVISION SUBJECT TO ARCH.COMMENT
B	29/11/2021	REVISION SUBJECT TO ARCH.COMMENT
A	18/10/2021	REVISION SUBJECT TO ARCH.COMMENT

JOB NO. : J-856

PROJECT :

PROPOSED DEVELOPMENT ABOVE  
LIGHT RAIL TIN WING STOP TSWTL  
NO.23,AREA 33,TIN SHUI WAI, N.T.

TITLE :

WINDOW SCHEDULE FOR  
TOWER 3 ALUM. WINDOW

DATE : 02-Aug-21 SCALE : 1:40

DRAWN BY : Ivon CHECKED BY :

**美特鋁質有限公司**  
MIDI ALUMINIUM FABRICATOR LTD.  
Units 6-8, Sunny Industrial Centre, 1/F  
610 Che Kwo Ling Road, Kowloon  
Tel:23489211-4 Fax:95227272666

DWG NO. : 856-SD-PW-5311 REV. : C

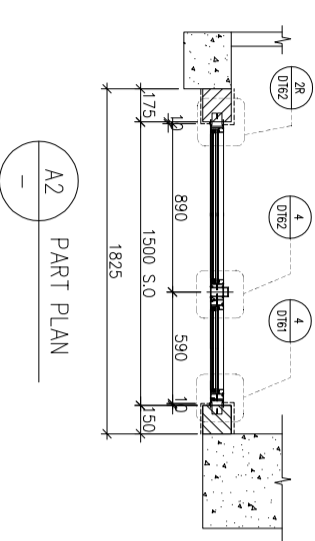
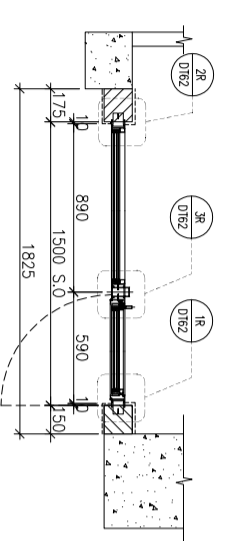
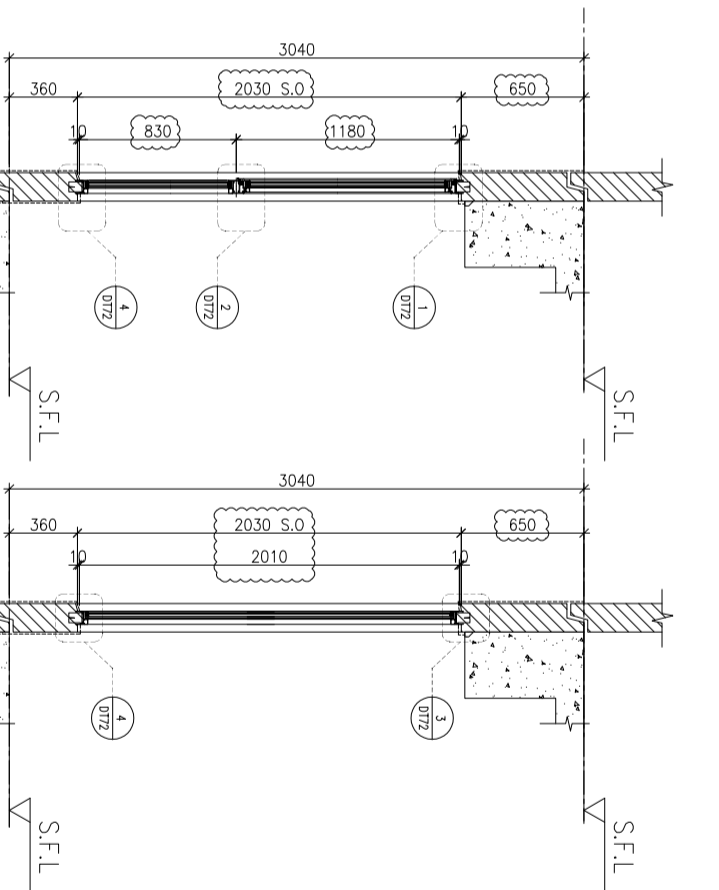
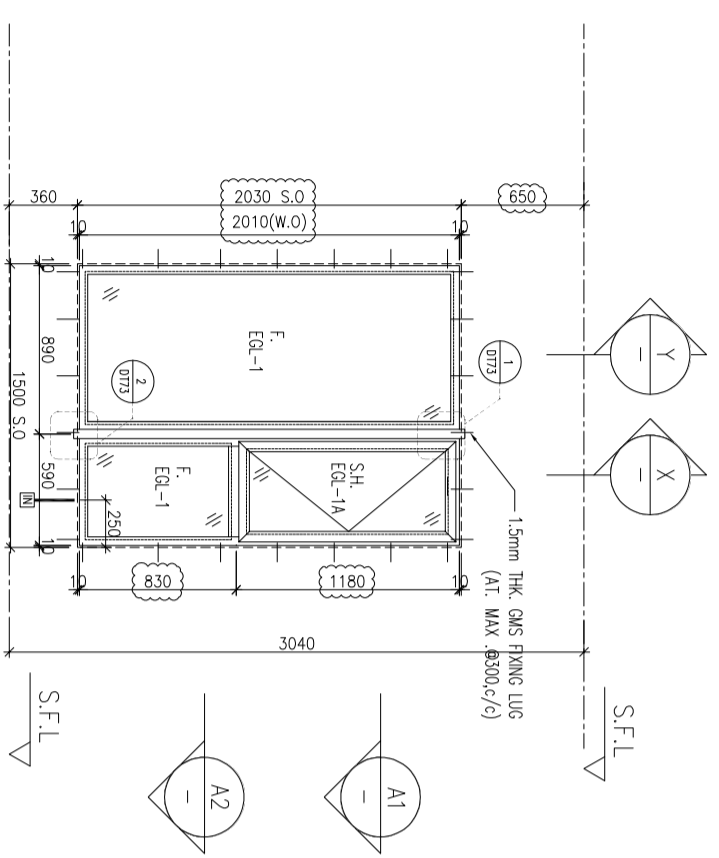

ELEVATION

WINDOW MARK	AW 03
LOCATION	3/F~42/F/4/F.13/F.14/F.24/F.34/F OMITTED) UNIT A1
SECTION	70mm ALUM. SECTION
GLAZING	EGL-1,EGL-1A
QUANTITY	35 Nos
REMARKS	FAÇADE(TYPE T3PF15 FOR 3/F~42/F)

B.O. REF :

CLIENT :

**SUN HUNG KAI**  
REAL ESTATE AGENCY LTD.  
42/F SUN HUNG KAI CENTRE, WANGCHAI, HONGKONG

ARCHITECT :

**IWK&partners**  
a r c h i t e c t s

MAIN CONTRACTOR :

**怡輝建築有限公司**  
Yee Fai Building Contractors Ltd.

STRUCTURAL ENGINEER :

**ARUP**

FAÇADE CONSULTANT:

**ALPHA CONSULTING LIMITED**  
Steel Structure & Façade Specialist

NOTE :

1. ALL DIMENSIONS ARE IN mm.
2. ALL ELEVATIONS ARE VIEWED FROM OUTSIDE.
3. ALL DIMENSIONS TO BE VERIFIED ON SITE BEFORE FABRICATION.

LEGEND :

- (X1) --- DETAIL MARK NO.
- (X001) --- REFER SHEET NO.
- 1. F.F.L. -- FINISHED FLOOR LEVEL
- 2. S.F.L. -- STRUCTURAL FLOOR LEVEL
- 3. (R) -- REVERSED DETAIL
- 4. GLASS LEGEND

EQ1-1 -- 8mmHS+12mm AIR GAP+10mmTP THK. I.G.U.  
 EQ1-2 -- 10mm THK. CLEAR TEMPERED GLASS  
 EQ1-4 -- 10mm THK. TEMPERED ACID ETCHED GLASS  
 EQ1-1A -- 8mmHS+12mm AIR GAP+8mmTP THK. I.G.U.

NO.	DATE	REVISION SUBJECT TO ARCH COMMENT	BY
B	14/12/2021	REVISION SUBJECT TO ARCH COMMENT	hvn
A	18/10/2021	REVISION SUBJECT TO ARCH COMMENT	hvn

JOB NO. : J-856

PROJECT :

PROPOSED DEVELOPMENT ABOVE  
LIGHT RAIL TIN WING STOP TSWTL  
NO.23, AREA 33, TIN SHUI WAI, N.T.

TITLE :

WINDOW SCHEDULE FOR  
TOWER 3 ALUM. WINDOW

DATE : 02-Aug-21 SCALE : 1:40

DRAWN BY : Ivorn CHECKED BY :

**美特鋁質有限公司**  
MIDI ALUMINIUM FABRICATOR LTD.  
Units 6-8, Sunny Industrial Centre, 1/F  
610 Che Kwo Ling Road, Kowloon  
Tel: 23489211-4 Fax: (852) 27272666

DWG NO. : 856-SD-PW-5312 REV. : B

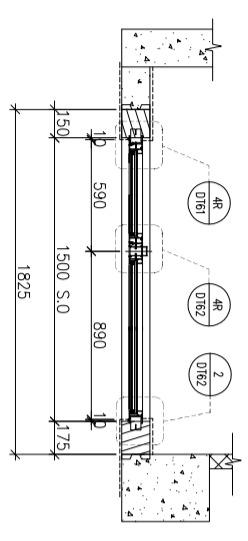
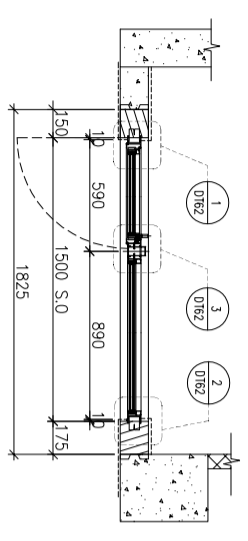
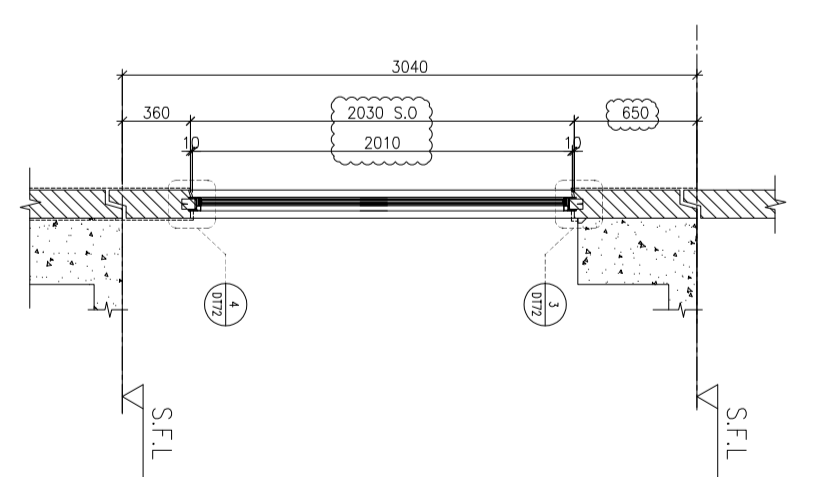
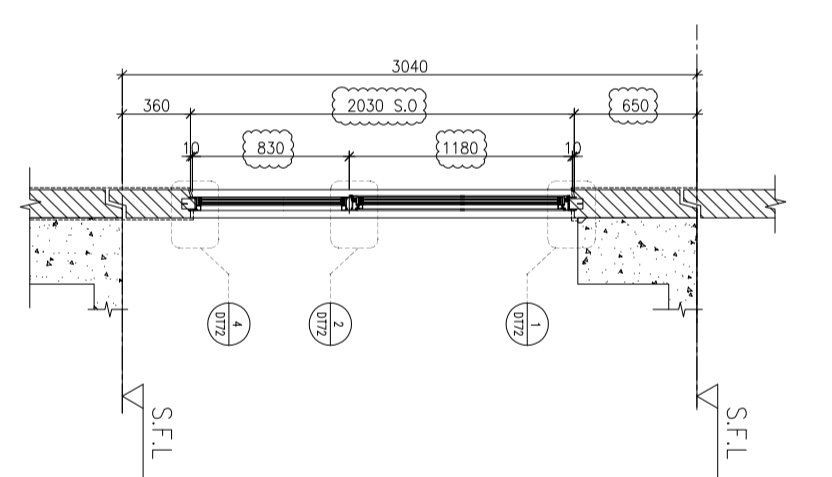
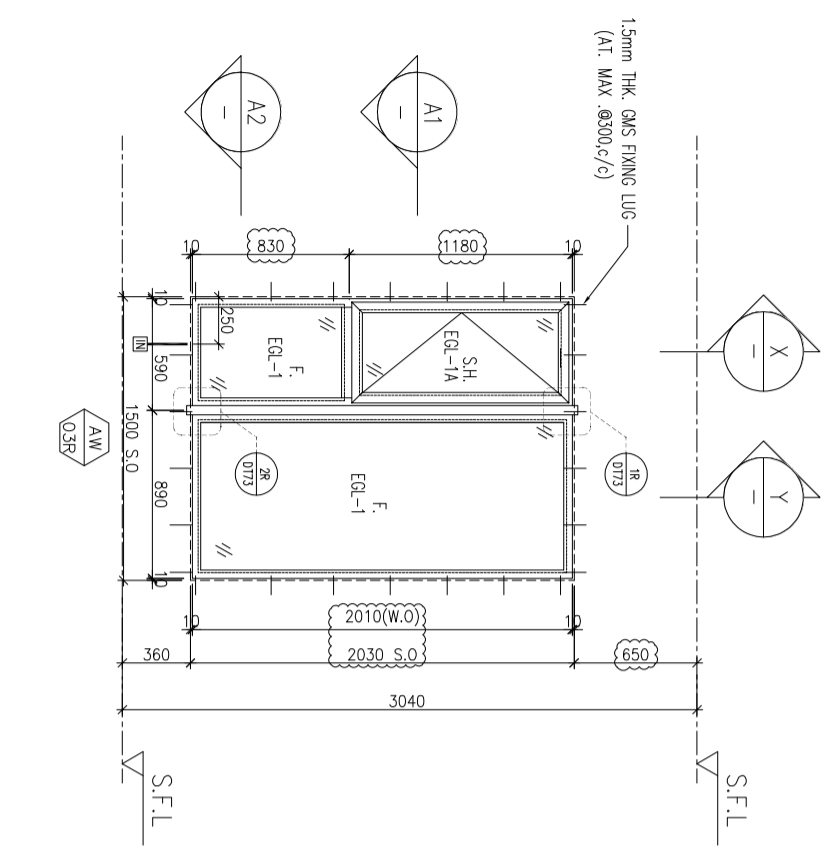

ELEVATION

WINDOW MARK	AW 035F
LOCATION	3/F~42/F/4/F.13/F.14/F.24/F.34/F OMITTED) UNIT A8
SECTION	70mm ALUM. SECTION
GLAZING	EGL-1, EGL-1A
QUANTITY	35 Nos
REMARKS	FAÇADE TYPE T3PF10 FOR 3/F~42/F)

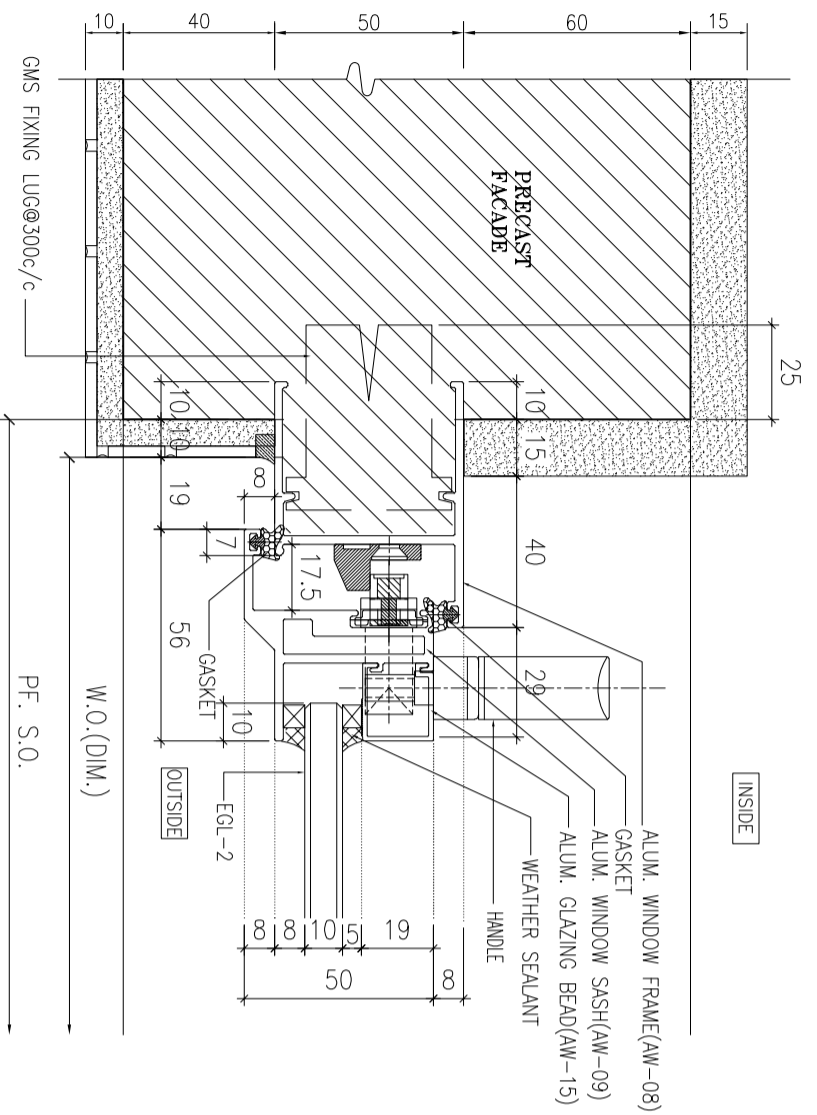

1 HORIZONTAL DETAIL  
SCALE 1:2

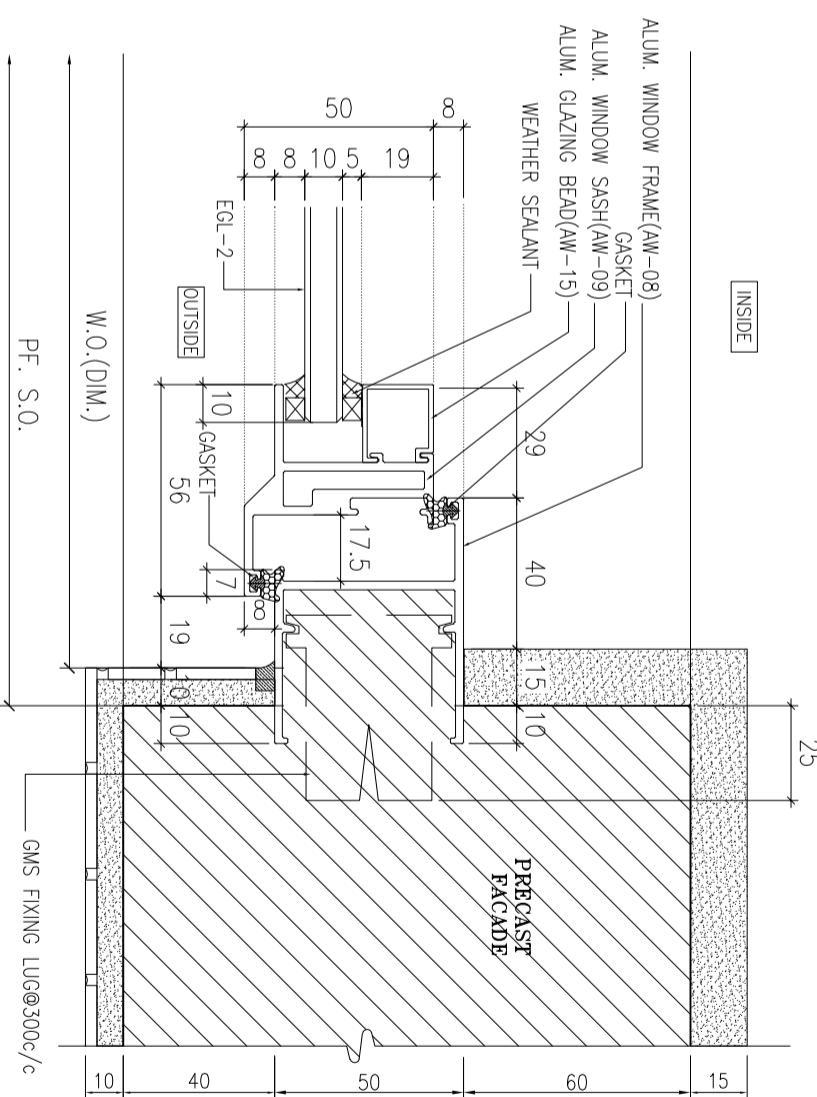

2 HORIZONTAL DETAIL  
SCALE 1:2

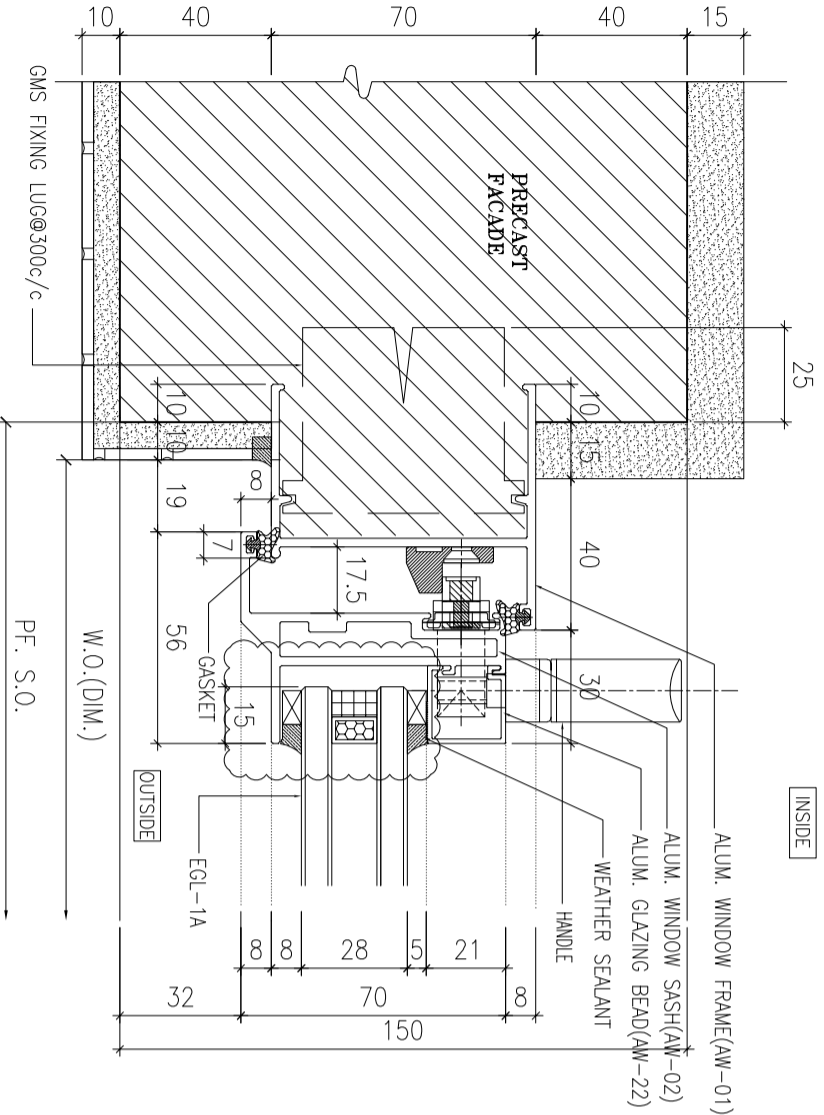

3 HORIZONTAL DETAIL  
SCALE 1:2

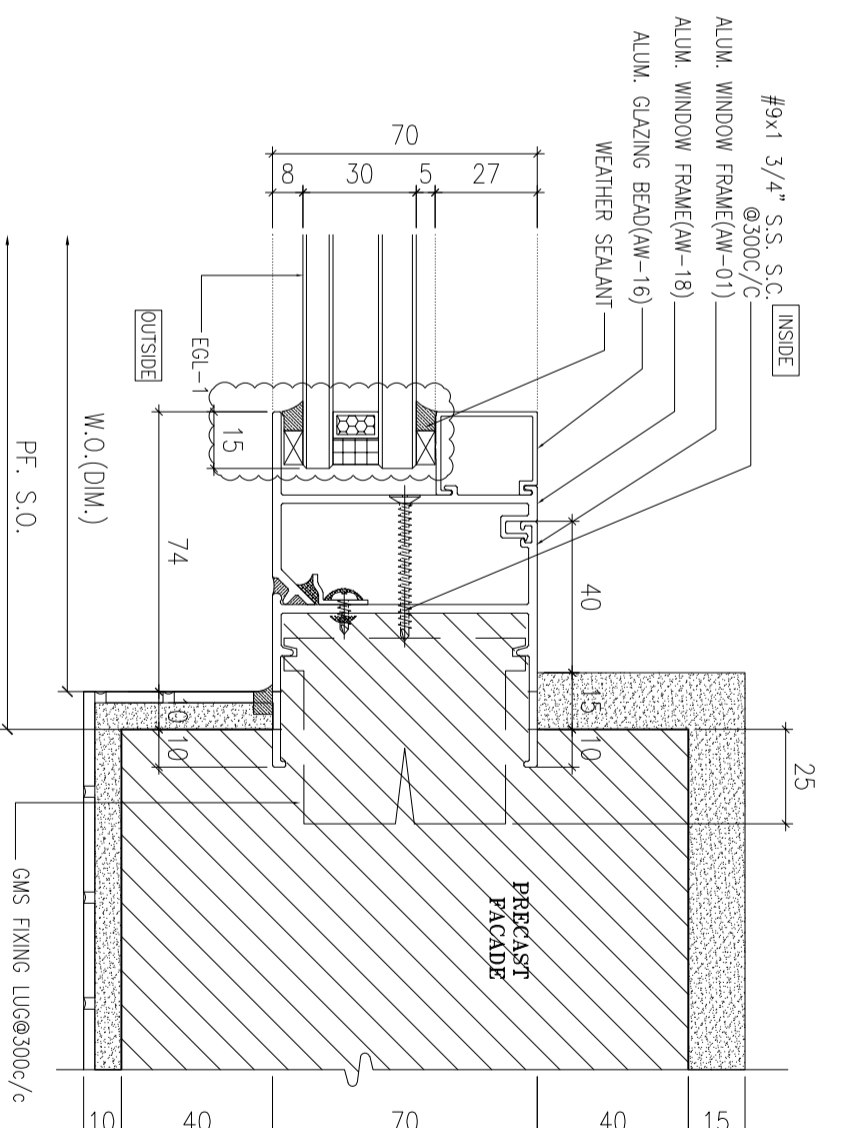

4 HORIZONTAL DETAIL  
SCALE 1:2

B.O. REF :

CLIENT :  
**SUN HUNG KAI**  
REAL ESTATE AGENCY LTD.  
42/F SUN HUNG KAI CENTRE, WANCHAI, HONGKONG

ARCHITECT :  
**IWK&partners**  
a r c h i t e c t s

MAIN CONTRACTOR :  
**怡輝建築有限公司**  
Yee Fai Building Contractors Ltd.

STRUCTURAL ENGINEER :  
**ARUP**

FAÇADE CONSULTANT:  
**ALPHA CONSULTING LIMITED**  
Steel Structure & Façade Specialist

NOTE :  
1. ALL DIMENSIONS ARE IN mm.  
2. ALL ELEVATIONS ARE VIEWED FROM OUTSIDE.  
3. ALL DIMENSIONS TO BE VERIFIED ON SITE BEFORE FABRICATION.

LEGEND :  
X1 --- DETAIL MARK NO.  
X001 --- REFER SHEET NO.

1. F.F.L.--FINISHED FLOOR LEVEL  
2. S.F.L.--STRUCTURAL FLOOR LEVEL  
3. (R) ---REVERSED DETAIL  
4. GLASS LEGEND  
EGL-1--9mmHS+12mm AIR GAP+10mmTP THK. I.G.U.  
EGL-2--10mm THK. CLEAR TEMPERED GLASS  
EGL-4--10mm THK. TEMPERED ACID ETCHED GLASS  
EGL-1A--8mmHS+12mm AIR GAP+8mmTP THK. I.G.U.

NO.	DATE	REVISION SUBJECT TO ARCH/COMMENT	BY
A	30/10/2021	REVISION SUBJECT TO ARCH/COMMENT	IVON

JOB NO. : J-856  
PROJECT : PROPOSED DEVELOPMENT ABOVE LIGHT RAIL TIN WING STOP TSWTL NO.23,AREA 33,TIN SHUI WAI, N.T.  
TITLE : TYPICAL DETAILS FOR ALUM. WINDOW

DATE : 02-Aug-21 SCALE : 1:40  
DRAWN BY : IVON CHECKED BY :

**美特鋁質有限公司**  
MIDI ALUMINIUM FABRICATOR LTD.  
Units 6-8, Sunny Industrial Centre, 1/F  
610 Che Kwo Ling Road, Kowloon  
Tel:23489211-4 Fax:8522727666  
DWG NO. : J856-SD-PW-DT61 REV. : B

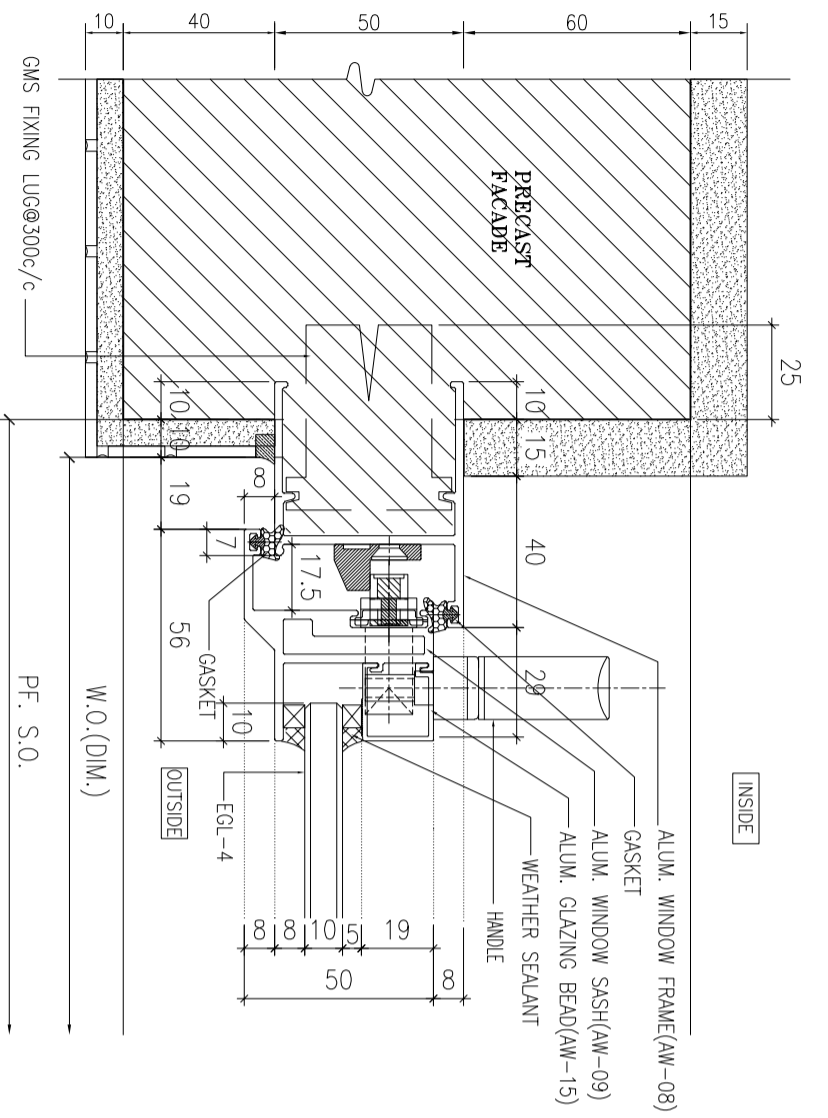

1 HORIZONTAL DETAIL  
SCALE 1:2

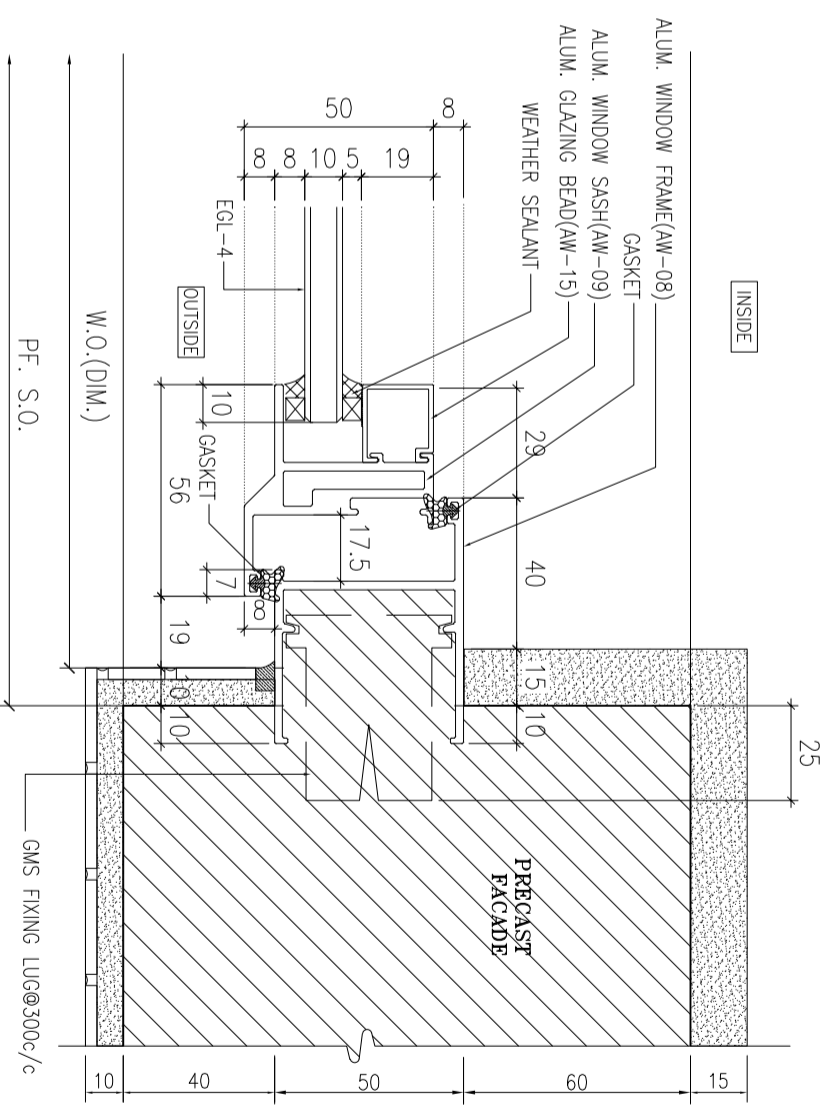

2 HORIZONTAL DETAIL  
SCALE 1:2

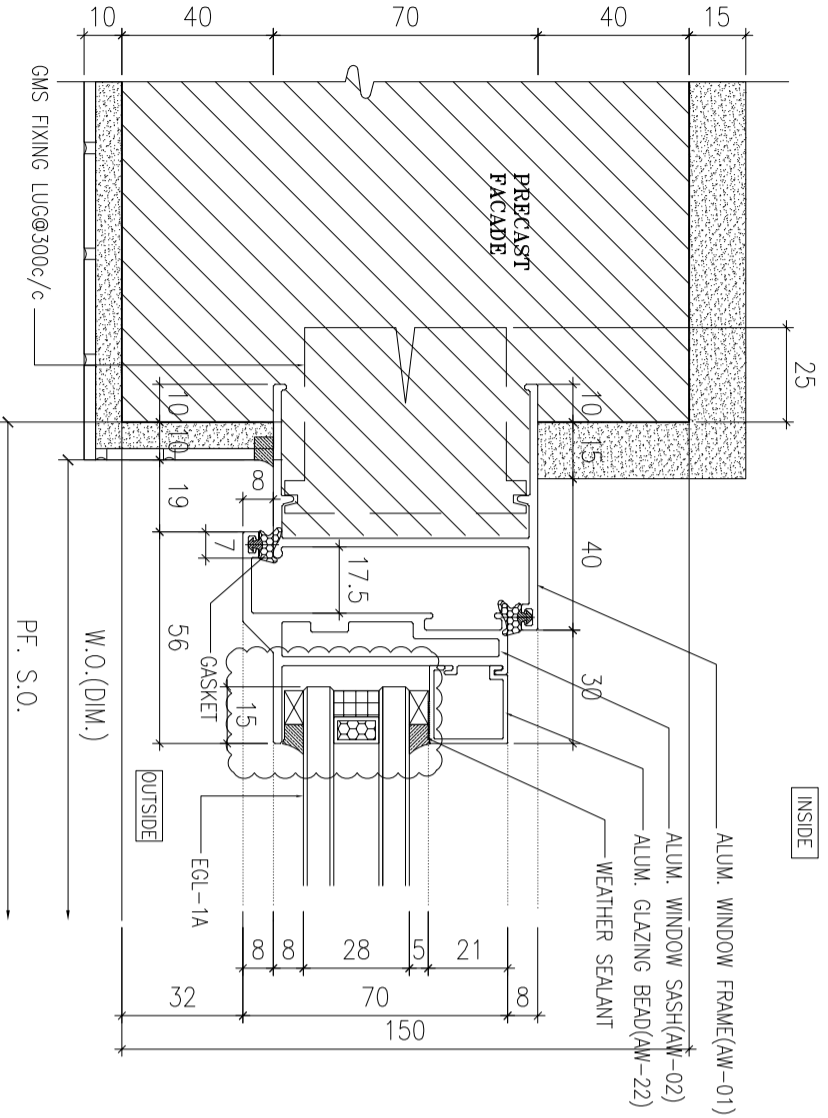

3 HORIZONTAL DETAIL  
SCALE 1:2

B.O. REF :

CLIENT :  
**SUN HUNG KAI**  
REAL ESTATE AGENCY LTD.  
42/F SUN HUNG KAI CENTRE, WANCHAI, HONGKONG

ARCHITECT :  
**IWK&partners**  
a r c h i t e c t s

MAIN CONTRACTOR :  
**怡耀建築有限公司**  
Yee Fai Building Contractors Ltd.

STRUCTURAL ENGINEER :  
**ARUP**

FAÇADE CONSULTANT:  
**ALPHA CONSULTING LIMITED**  
Steel Structure & Façade Specialist

NOTE :  
1. ALL DIMENSIONS ARE IN mm.  
2. ALL ELEVATIONS ARE VIEWED FROM OUTSIDE.  
3. ALL DIMENSIONS TO BE VERIFIED ON SITE BEFORE FABRICATION.

LEGEND :  
X1 — DETAIL MARK NO.  
X001 — REFER SHEET NO.

1. F.F.L.--FINISHED FLOOR LEVEL
2. S.F.L.--STRUCTURAL FLOOR LEVEL
3. (R) --REVERSED DETAIL
4. GLASS LEGEND  
EGL-1--8mmHS+12mm AIR GAP+10mmTP THK. I.G.U.  
EGL-2--10mm THK. CLEAR TEMPERED GLASS  
EGL-4--10mm THK. TEMPERED ACID ETCHED GLASS  
EGL-1A--8mmHS+12mm AIR GAP+8mmTP THK. I.G.U.

NO.	DATE	REVISION SUBJECT TO ARCH/COMMENT	BY
B	02/11/2021	REVISION SUBJECT TO ARCH/COMMENT	lvan
A	30/10/2021	REVISION SUBJECT TO ARCH/COMMENT	lvan

JOB NO. : J-856

PROJECT :  
PROPOSED DEVELOPMENT ABOVE  
LIGHT RAIL TIN WING STOP TSWTL  
NO.23,AREA 33,TIN SHUI WAI, N.T.

TITLE :  
TYPICAL DETAILS FOR  
ALUM. WINDOW

DATE : 02-Aug-21 SCALE : 1:40  
DRAWN BY : lvan CHECKED BY :

**美特鋁質有限公司**  
MIDI ALUMINIUM FABRICATOR LTD.  
Units 6-8, Sunny Industrial Centre, 1/F  
610 Che Kwo Ling Road, Kowloon  
Tel:23489211-4 Fax:8522727666  
DWG NO. : JB56-SD-PW-DT610 REV. : B



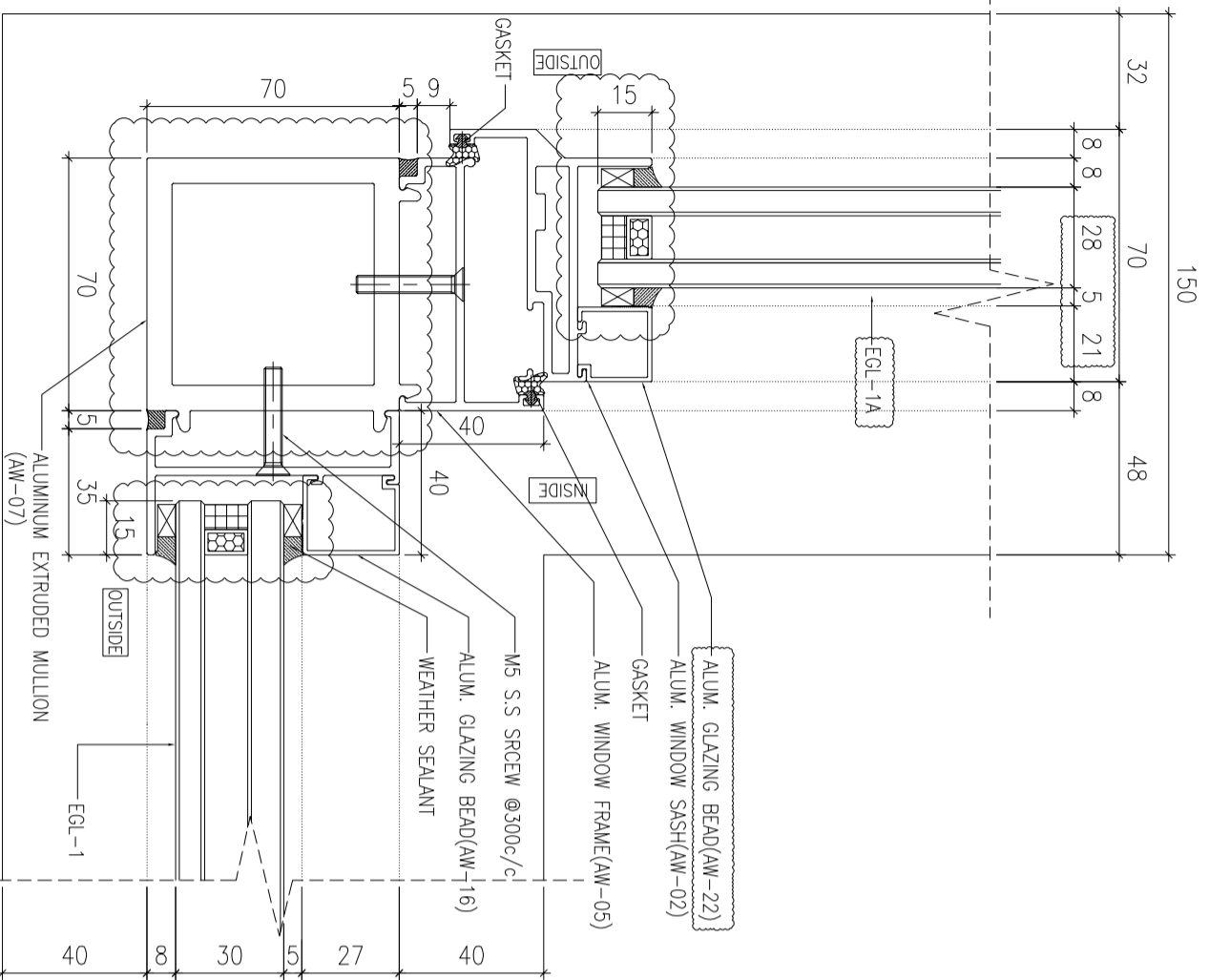

1 HORIZONTAL DETAIL  
SCALE 1:2

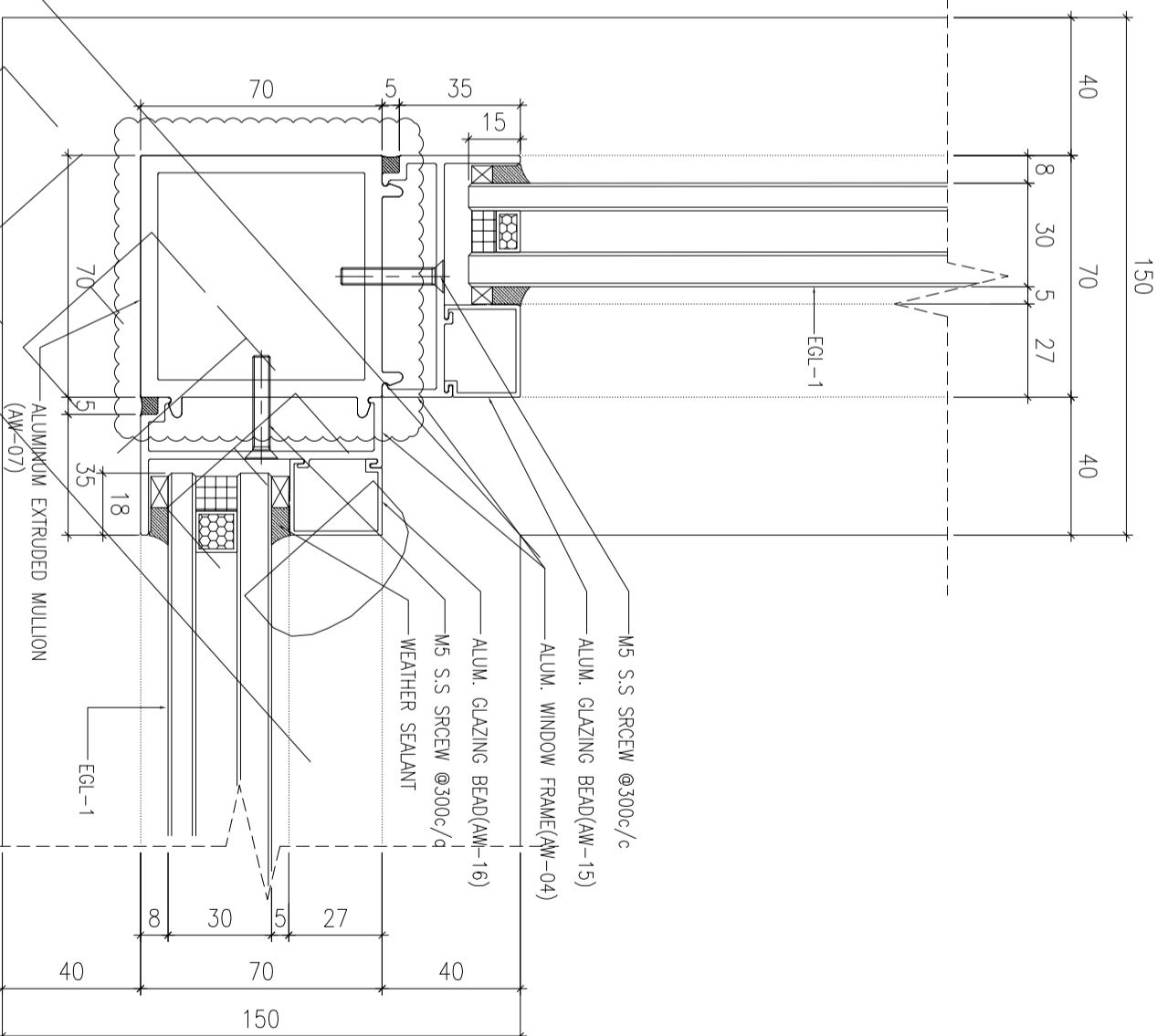

2 HORIZONTAL DETAIL  
SCALE 1:2

B.O. REF :

CLIENT :

**SUN HUNG KAI**  
REAL ESTATE AGENCY LTD.  
42/F SUN HUNG KAI CENTRE, WANGCHAI, HONGKONG

ARCHITECT :

**IWK&partners**  
a r c h i t e c t s

MAIN CONTRACTOR :

**怡輝建築有限公司**  
Yee Fai Building Contractors Ltd.

STRUCTURAL ENGINEER :

**ARUP**  
Steel Structure & Facade Specialist

FAÇADE CONSULTANT:

**ALPHA CONSULTING LIMITED**  
Steel Structure & Facade Specialist

NOTE :

1. ALL DIMENSIONS ARE IN mm.
2. ALL ELEVATIONS ARE VIEWED FROM OUTSIDE.
3. ALL DIMENSIONS TO BE VERIFIED ON SITE BEFORE FABRICATION.

LEGEND :

X1 - DETAIL MARK NO.  
X001 - REFER SHEET NO.

1. F.F.L. -- FINISHED FLOOR LEVEL
2. S.F.L. -- STRUCTURAL FLOOR LEVEL
3. (R) -- REVERSED DETAIL

4. GLASS LEGEND

- EGL-1 -- 9mmHS+12mm AIR GAP+10mmTP THK. I.G.U.
- EGL-2 -- 10mm THK. CLEAR TEMPERED GLASS
- EGL-4 -- 10mm THK. TEMPERED ACID ETCHED GLASS
- EGL-1A -- 8mmHS+12mm AIR GAP+8mmTP THK. I.G.U.

NO.	DATE	REVISION
C	02/11/2021	REVISION SUBJECT TO ARCH.COMMENT
B	30/09/2021	REVISION SUBJECT TO ARCH.COMMENT
A	30/09/2021	REVISION SUBJECT TO ARCH.COMMENT

JOB NO. : J-856

PROJECT :  
PROPOSED DEVELOPMENT ABOVE  
LIGHT RAIL TIN WING STOP TSWTL  
NO.23,AREA 33,TIN SHUI WAI, N.T.

TITLE :  
TYPICAL DETAILS FOR  
ALUM. WINDOW

DATE : 02-Aug-21 SCALE : 1:40

DRAWN BY : Ivorn CHECKED BY :

**MIDI ALUMINIUM FABRICATOR LTD.**  
Units 6-8, Sunny Industrial Centre, 1/F  
610 Che Kwo Ling Road, Kowloon  
Tel:23489211-4 Fax:8522727666  
DWG NO. : JB56-SD-PW-DT63 REV. : C

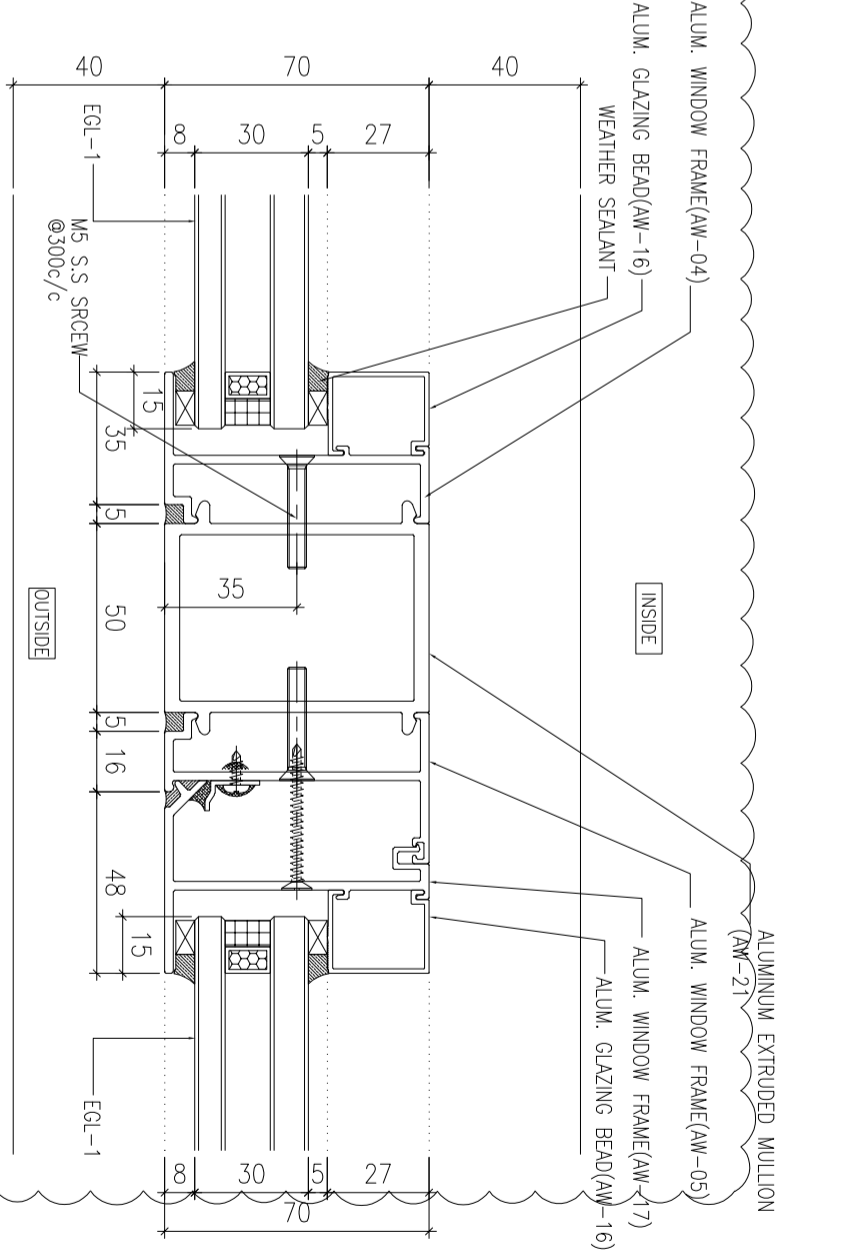
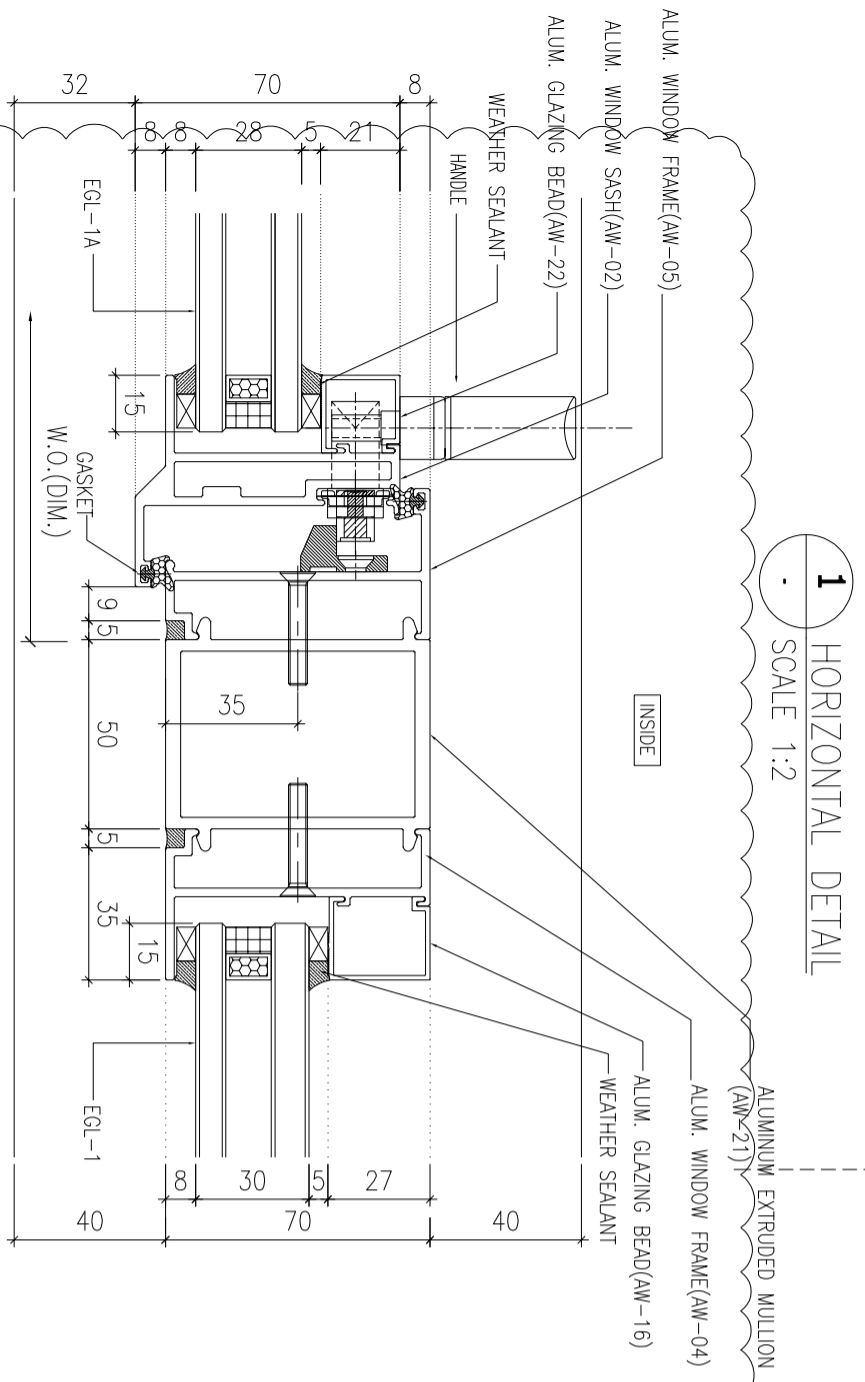
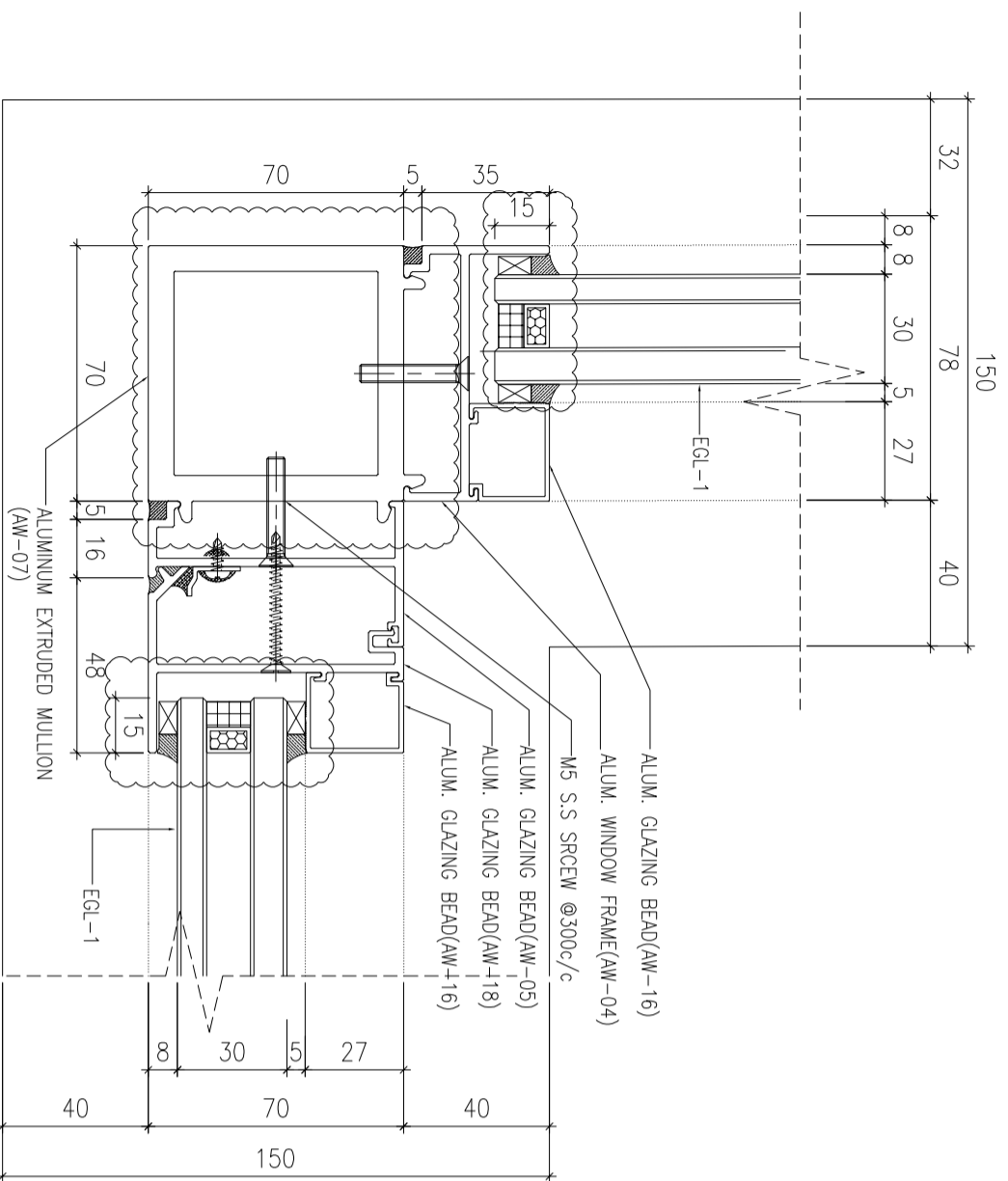

B.O. REF :

CLIENT :  
SUN HUNG KAI  
REAL ESTATE AGENCY LTD.  
42/F SUN HUNG KAI CENTRE, WANCHAI, HONGKONG

ARCHITECT :  
IWK&partners  
a r c h i t e c t s

MAIN CONTRACTOR :  
怡輝建築有限公司  
Yee Fai Building Contractors Ltd.

STRUCTURAL ENGINEER :  
ARUP

FAÇADE CONSULTANT:  
ALPHA CONSULTING LIMITED  
Steel Structure & Façade Specialist

NOTE :  
1. ALL DIMENSIONS ARE IN mm.  
2. ALL ELEVATIONS ARE VIEWED FROM OUTSIDE.  
3. ALL DIMENSIONS TO BE VERIFIED ON SITE BEFORE FABRICATION.

LEGEND :  
X1 --- DETAIL MARK NO.  
X001 --- REFER SHEET NO.

1. F.F.L.--FINISHED FLOOR LEVEL  
2. S.F.L.--STRUCTURAL FLOOR LEVEL  
3. (R) --REVERSED DETAIL  
4. GLASS LEGEND  
EGL-1--9mmHS+12mm AIR GAP+10mmTP THK. I.G.U.  
EGL-2--10mm THK. CLEAR TEMPERED GLASS  
EGL-4--10mm THK. TEMPERED ACID ETCHED GLASS  
EGL-1A--9mmHS+12mm AIR GAP+9mmTP THK. I.G.U.

NO.	DATE	REVISION
D	02/11/2021	REVISION SUBJECT TO ARCH.COMMENT I/IV
C	30/10/2021	REVISION SUBJECT TO ARCH.COMMENT I/IV
B	18/10/2021	REVISION SUBJECT TO ARCH.COMMENT I/IV
A	30/09/2021	REVISION SUBJECT TO ARCH.COMMENT I/IV

JOB NO. : J-856  
PROJECT : PROPOSED DEVELOPMENT ABOVE LIGHT RAIL TIN WING STOP TSWTL NO.23,AREA 33,TIN SHUI WAI, N.T.  
TITLE : TYPICAL DETAILS FOR ALUM. WINDOW  
DATE : 02-Aug-21 SCALE : 1:40  
DRAWN BY : I/IVN CHECKED BY :  
UNITS 6-8, SUMYO INDUSTRIAL CENTRE, 1/F, 610 Che Kwo Ling Road, Kowloon  
Tel:23489211-4 Fax:(852)27270666  
DWG NO. : J856-SD-PW-DT64 REV. : D

MIDI ALUMINIUM FABRICATOR LTD.  
Units 6-8, Sumyo Industrial Centre, 1/F, 610 Che Kwo Ling Road, Kowloon  
Tel:23489211-4 Fax:(852)27270666  
Dwg No. : J856-SD-PW-DT64 Rev. : D

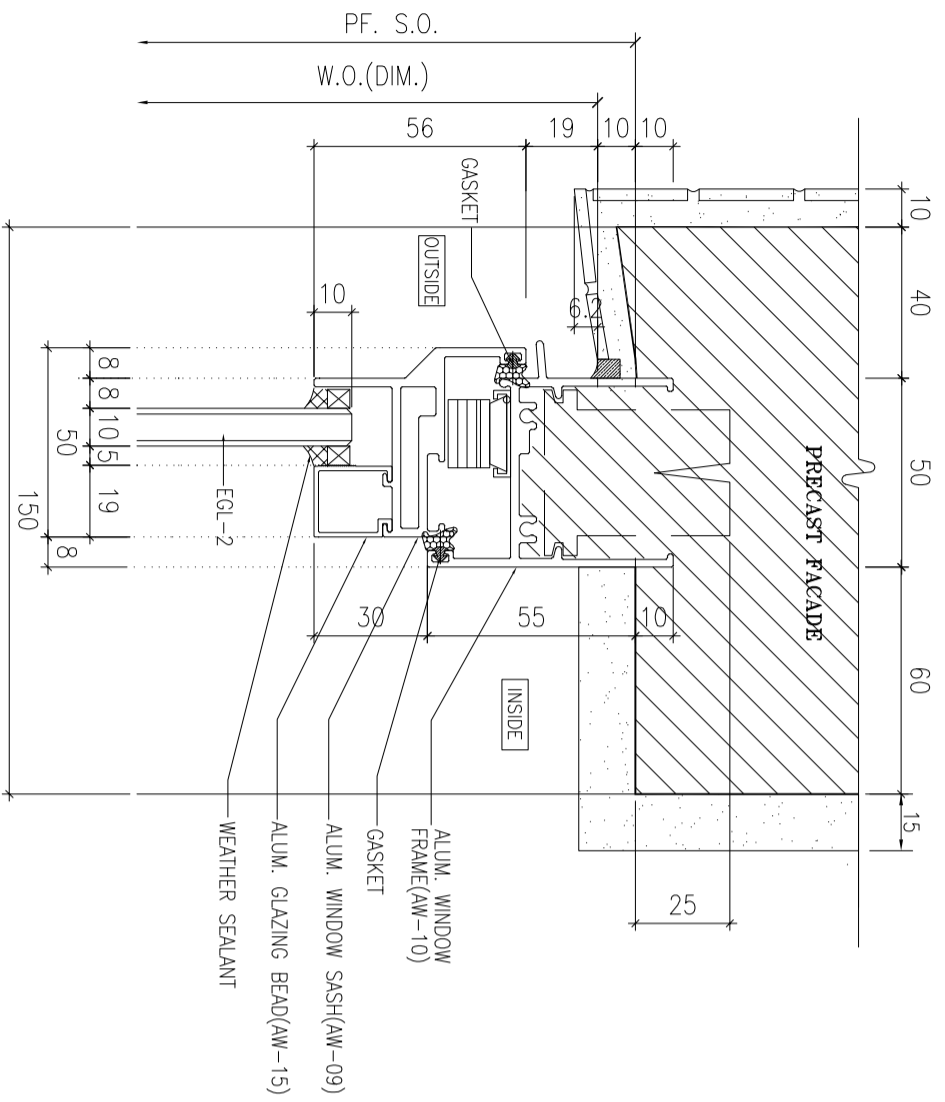

1 HORIZONTAL DETAIL  
SCALE 1:2  
150

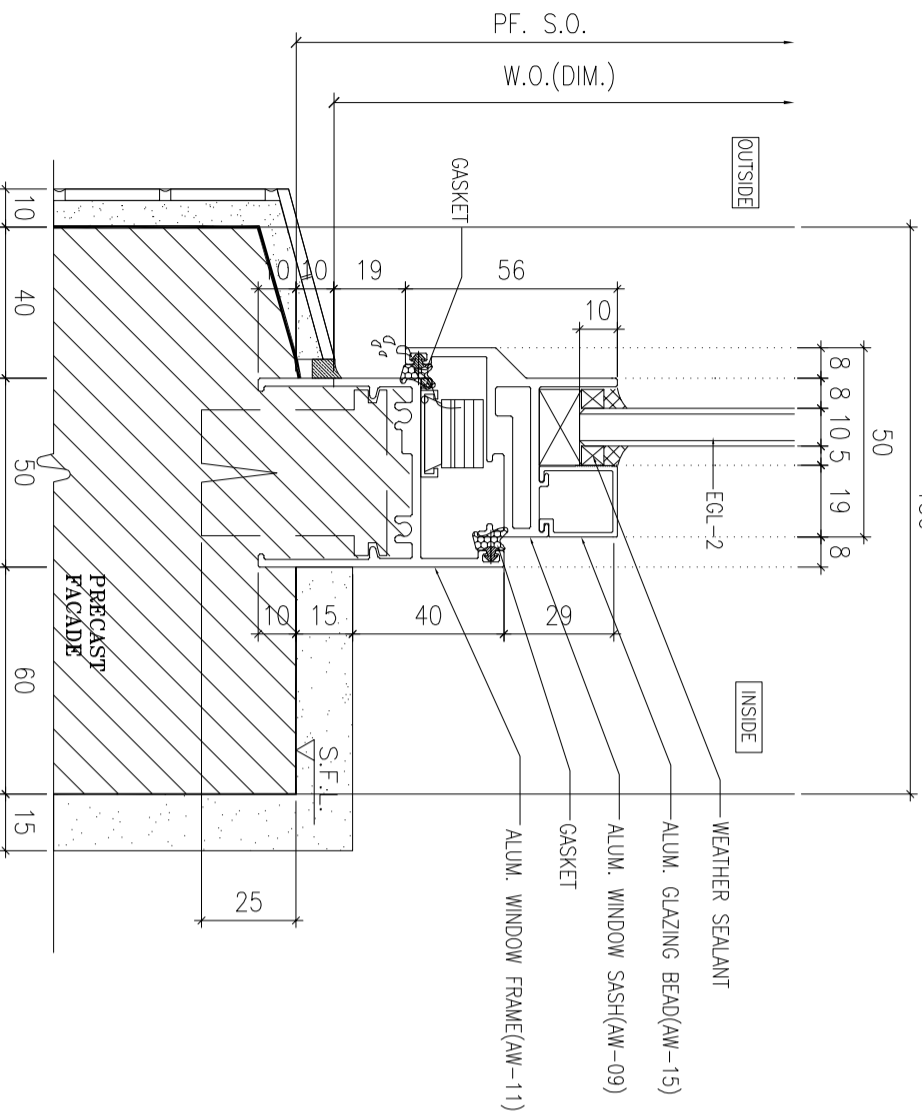

2 HORIZONTAL DETAIL  
SCALE 1:2

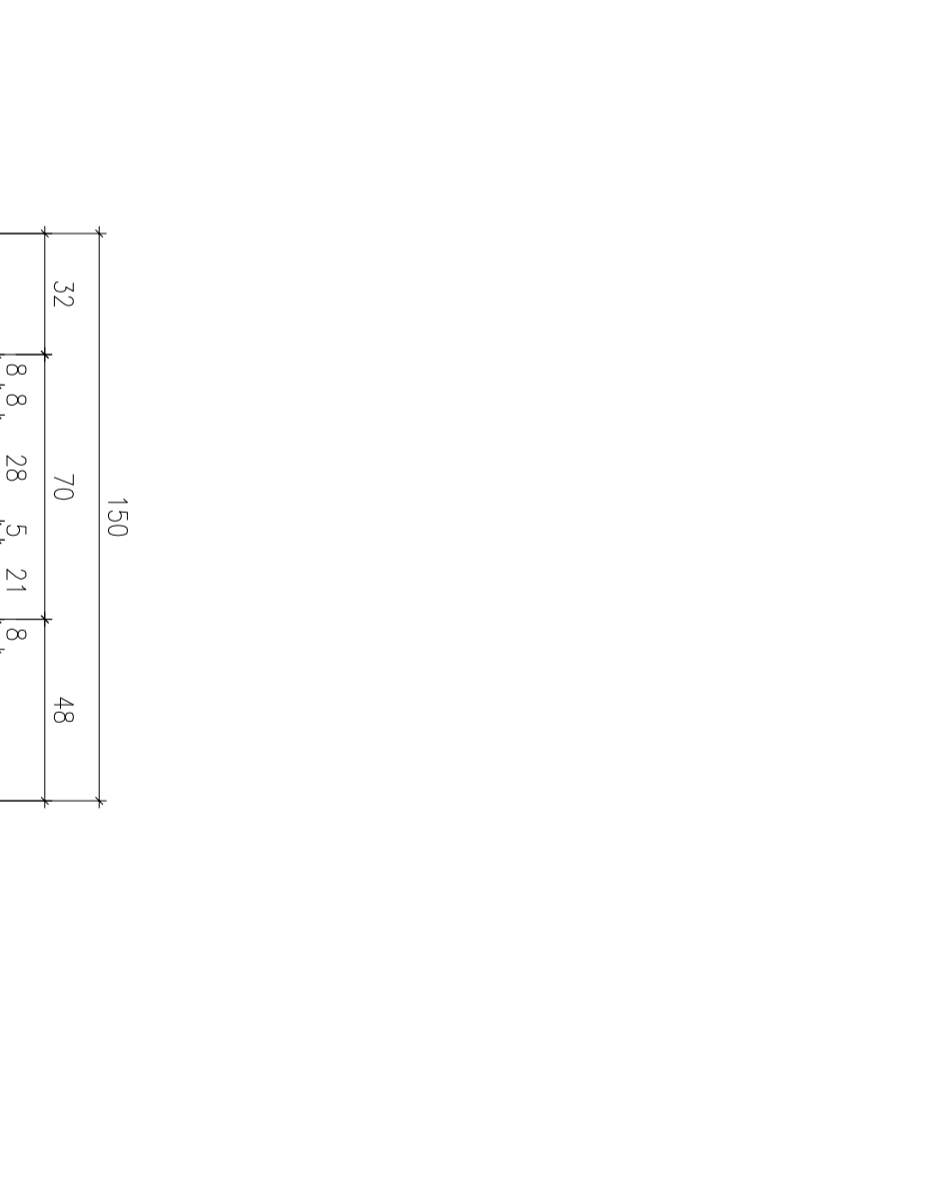

3 HORIZONTAL DETAIL  
SCALE 1:2

B.O. REF :

CLIENT :  
**SUN HUNG KAI**  
REAL ESTATE AGENCY LTD.  
42/F SUN HUNG KAI CENTRE, WANGCHAI, HONGKONG

ARCHITECT :  
**IWK&partners**  
a r c h i t e c t s

MAIN CONTRACTOR :  
**怡輝建築有限公司**  
Yee Fai Building Contractors Ltd.

STRUCTURAL ENGINEER :  
**ARUP**

FAÇADE CONSULTANT:  
**ALPHA CONSULTING LIMITED**  
Steel Structure & Façade Specialist

NOTE :  
1. ALL DIMENSIONS ARE IN mm.  
2. ALL ELEVATIONS ARE VIEWED FROM OUTSIDE.  
3. ALL DIMENSIONS TO BE VERIFIED ON SITE BEFORE FABRICATION.  
LEGEND :

X1 DETAIL MARK NO.  
X001 REFER SHEET NO.  
1. F.F.L.--FINISHED FLOOR LEVEL  
2. S.F.L.--STRUCTURAL FLOOR LEVEL  
3. (R) --REVERSED DETAIL  
4. GLASS LEGEND  
EGL-1--8mmHS+12mm AIR GAP+10mmTP THK. I.G.U.  
EGL-2--10mm THK. CLEAR TEMPERED GLASS  
EGL-4--10mm THK. TEMPERED ACID ETCHED GLASS  
EGL-1A--8mmHS+12mm AIR GAP+8mmTP THK. I.G.U.

NO.	DATE	REVISION SUBJECT TO ARCH/COMMENT	BY
A	30/10/2021	REVISION SUBJECT TO ARCH/COMMENT	WYH
B	02/11/2021	REVISION SUBJECT TO ARCH/COMMENT	WYH

JOB NO. : J-856  
PROJECT : PROPOSED DEVELOPMENT ABOVE LIGHT RAIL TIN WING STOP TSWTL NO.23,AREA 33,TIN SHUI WAI, N.T.  
TITLE : TYPICAL DETAILS FOR ALUM. WINDOW  
DATE : 02-Aug-21 SCALE : 1:40  
DRAWN BY : IYon CHECKED BY :

**美特鋁質有限公司**  
MIDI ALUMINIUM FABRICATOR LTD.  
Units 6-8, Sunny Industrial Centre, 1/F  
610 Che Kwo Ling Road, Kowloon  
Tel:23489211-4 Fax:(852)27272666  
DWG NO. : J856-SD-PW-DT71 REV. : B

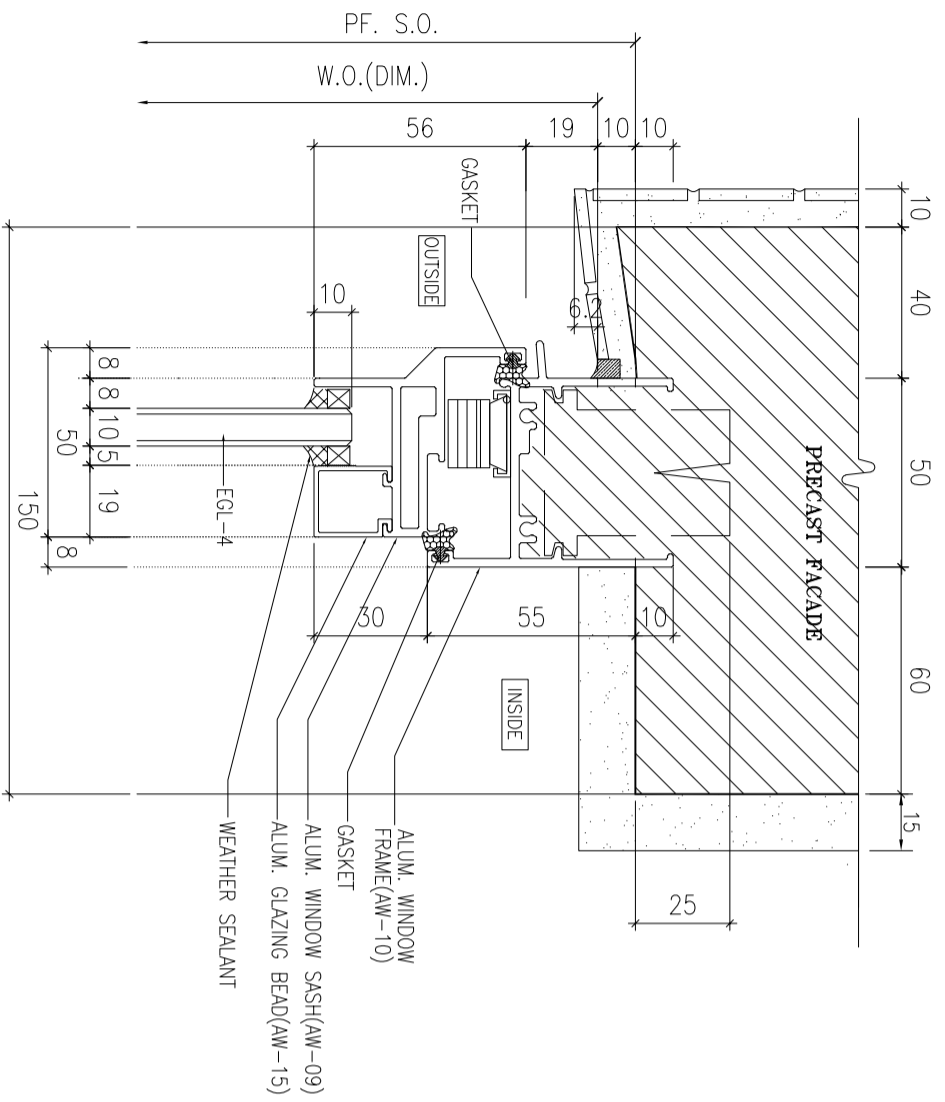

1 HORIZONTAL DETAIL  
SCALE 1:2  
150

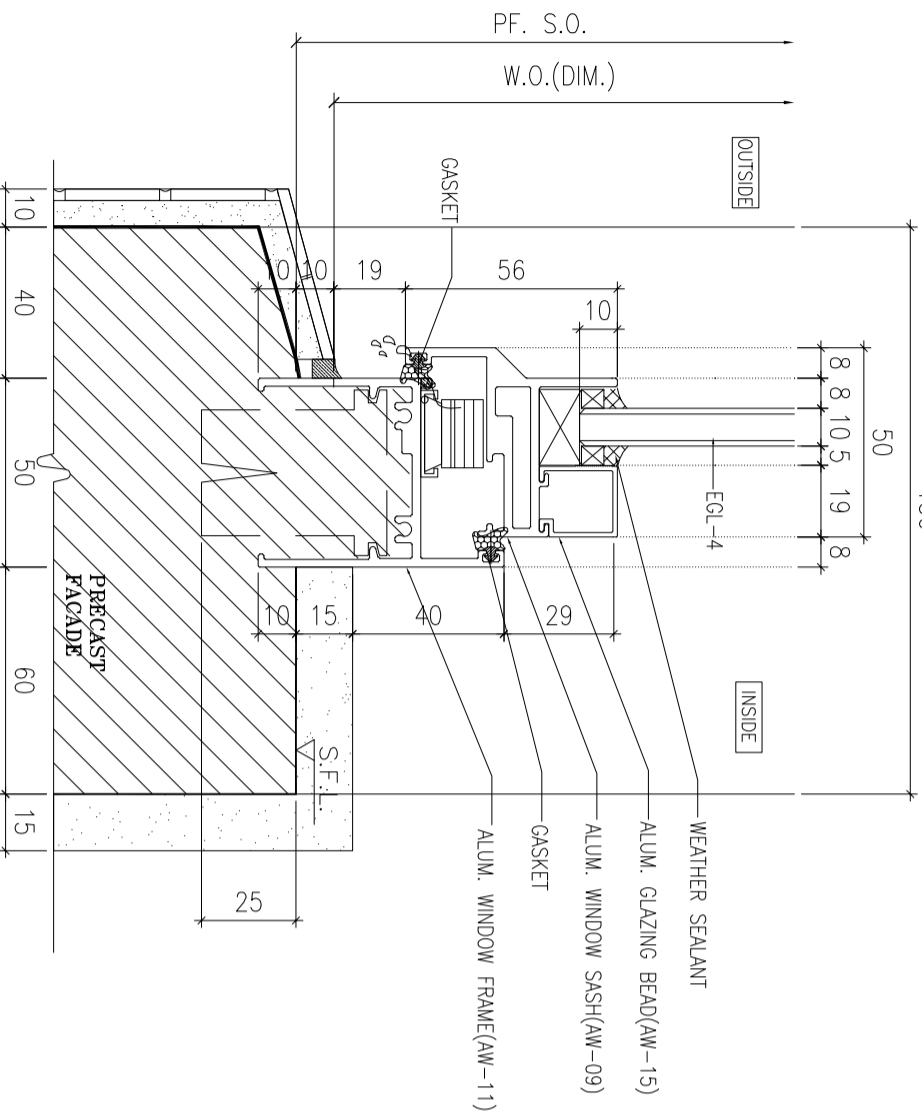

2 HORIZONTAL DETAIL  
SCALE 1:2

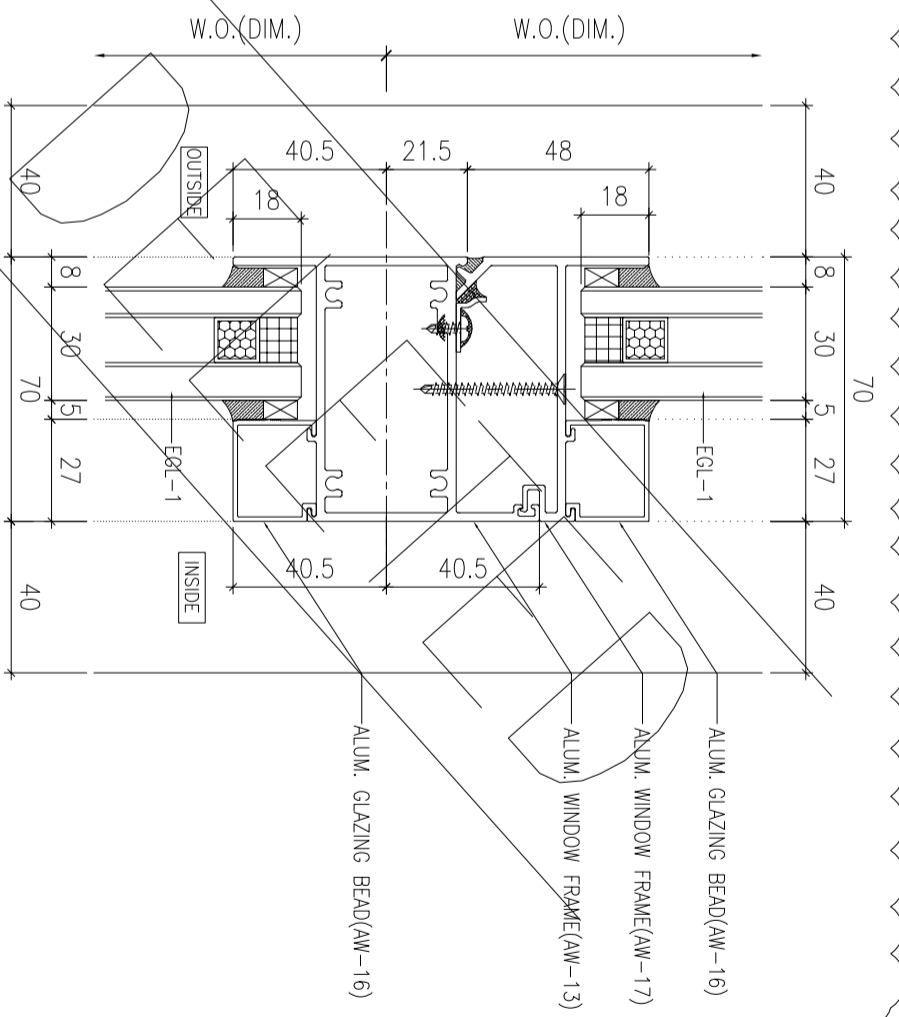

3 HORIZONTAL DETAIL  
SCALE 1:2

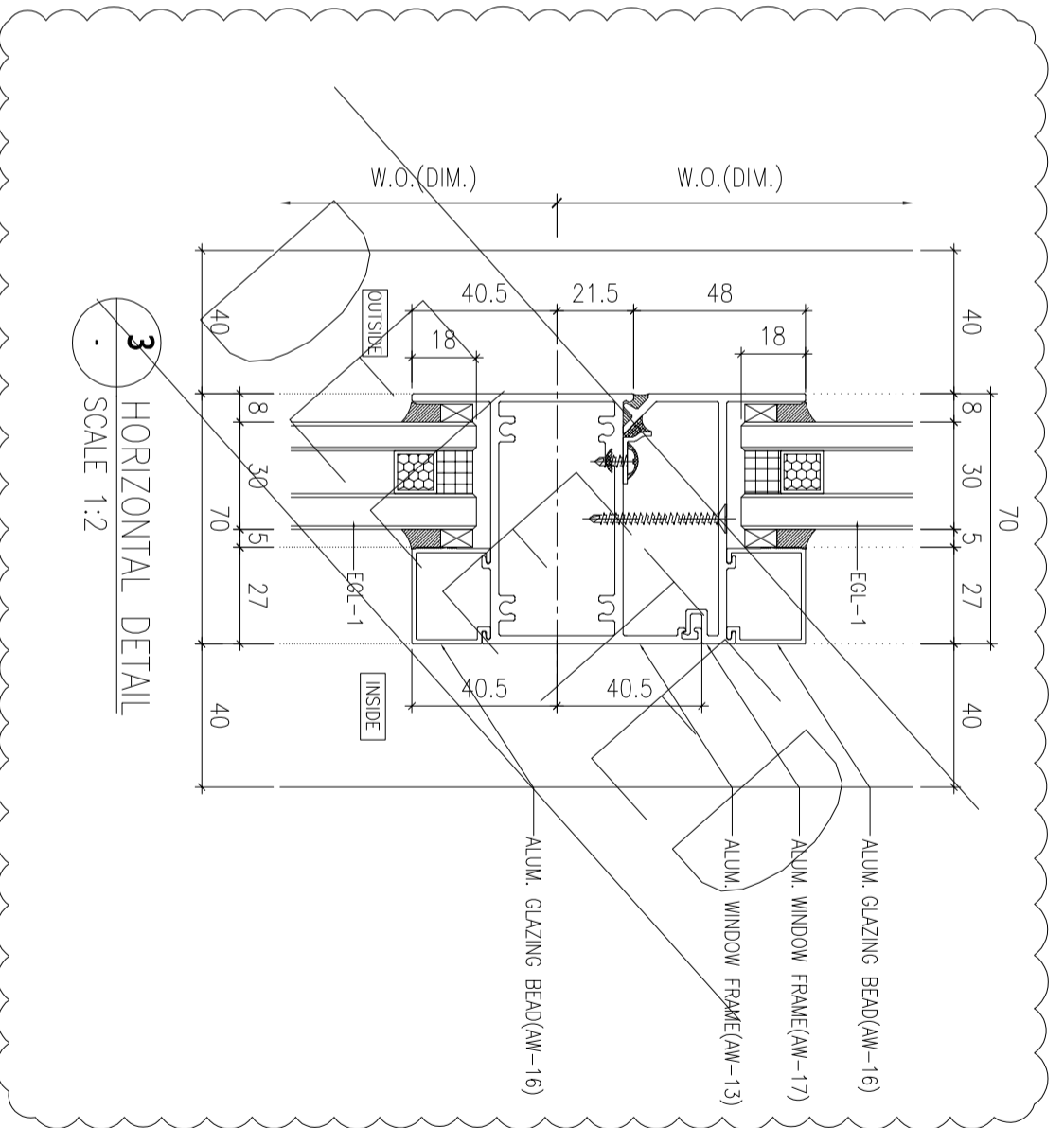

B.O. REF :

CLIENT :  
**SUN HUNG KAI**  
REAL ESTATE AGENCY LTD.  
42/F SUN HUNG KAI CENTRE, WANGCHAI, HONGKONG

ARCHITECT :  
**IWK&partners**  
a r c h i t e c t s

MAIN CONTRACTOR :  
**怡和建築有限公司**  
Yee Fai Building Contractors Ltd.

STRUCTURAL ENGINEER :  
**ARUP**

FAÇADE CONSULTANT:  
**ALPHA CONSULTING LIMITED**  
Steel Structure & Façade Specialist

NOTE :  
1. ALL DIMENSIONS ARE IN mm.  
2. ALL ELEVATIONS ARE VIEWED FROM OUTSIDE.  
3. ALL DIMENSIONS TO BE VERIFIED ON SITE BEFORE FABRICATION.

LEGEND :  
X1 --- DETAIL MARK NO.  
X001 --- REFER SHEET NO.

1. F.F.L.--FINISHED FLOOR LEVEL
2. S.F.L.--STRUCTURAL FLOOR LEVEL
3. (R) --REVERSED DETAIL
4. GLASS LEGEND  
EGL-1--8mmHS+12mm AIR GAP+10mmTP THK. I.G.U.  
EGL-2--10mm THK. CLEAR TEMPERED GLASS  
EGL-4--10mm THK. TEMPERED ACID ETCHED GLASS  
EGL-1A--8mmHS+12mm AIR GAP+8mmTP THK. I.G.U.

NO.	DATE	REVISION SUBJECT TO ARCH COMMENT	BY
B	02/11/2021	REVISION SUBJECT TO ARCH COMMENT	lvn
A	30/10/2021	REVISION SUBJECT TO ARCH COMMENT	lvn

JOB NO. : J-856  
PROJECT : PROPOSED DEVELOPMENT ABOVE LIGHT RAIL TIN WING STOP TSWTL NO.23,AREA 33,TIN SHUI WAI, N.T.  
TITLE : TYPICAL DETAILS FOR ALUM. WINDOW

DATE : 02-Aug-21 SCALE : 1:40  
DRAWN BY : lvon CHECKED BY :

**美特鋁質有限公司**  
MIDI ALUMINIUM FABRICATOR LTD.  
Units 6-8, Sunny Industrial Centre, 1/F  
610 Che Kwo Ling Road, Kowloon  
Tel:23489211-4 Fax:8522727666  
DWG NO. : JB56-SD-PW-DT71a REV. : B

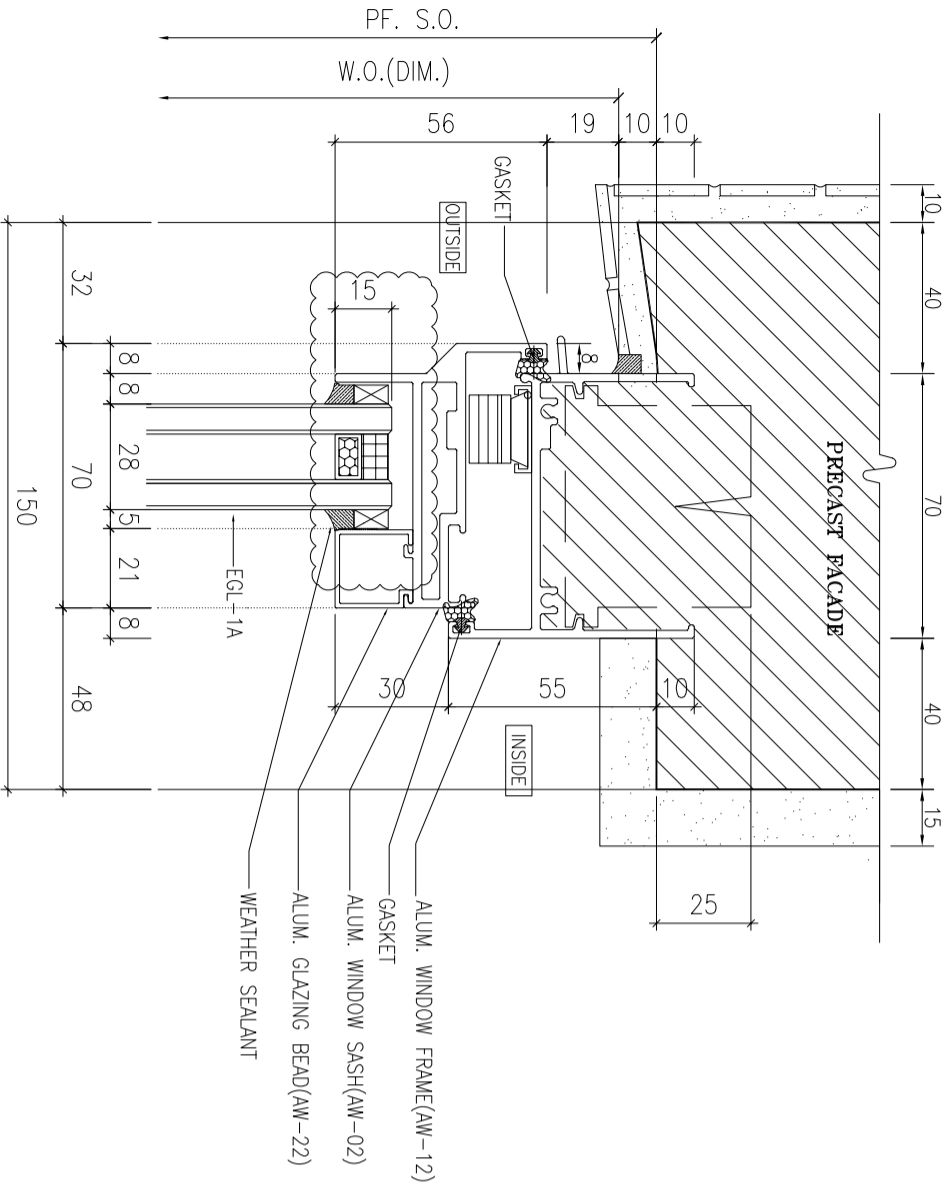

1 HORIZONTAL DETAIL  
SCALE 1:2

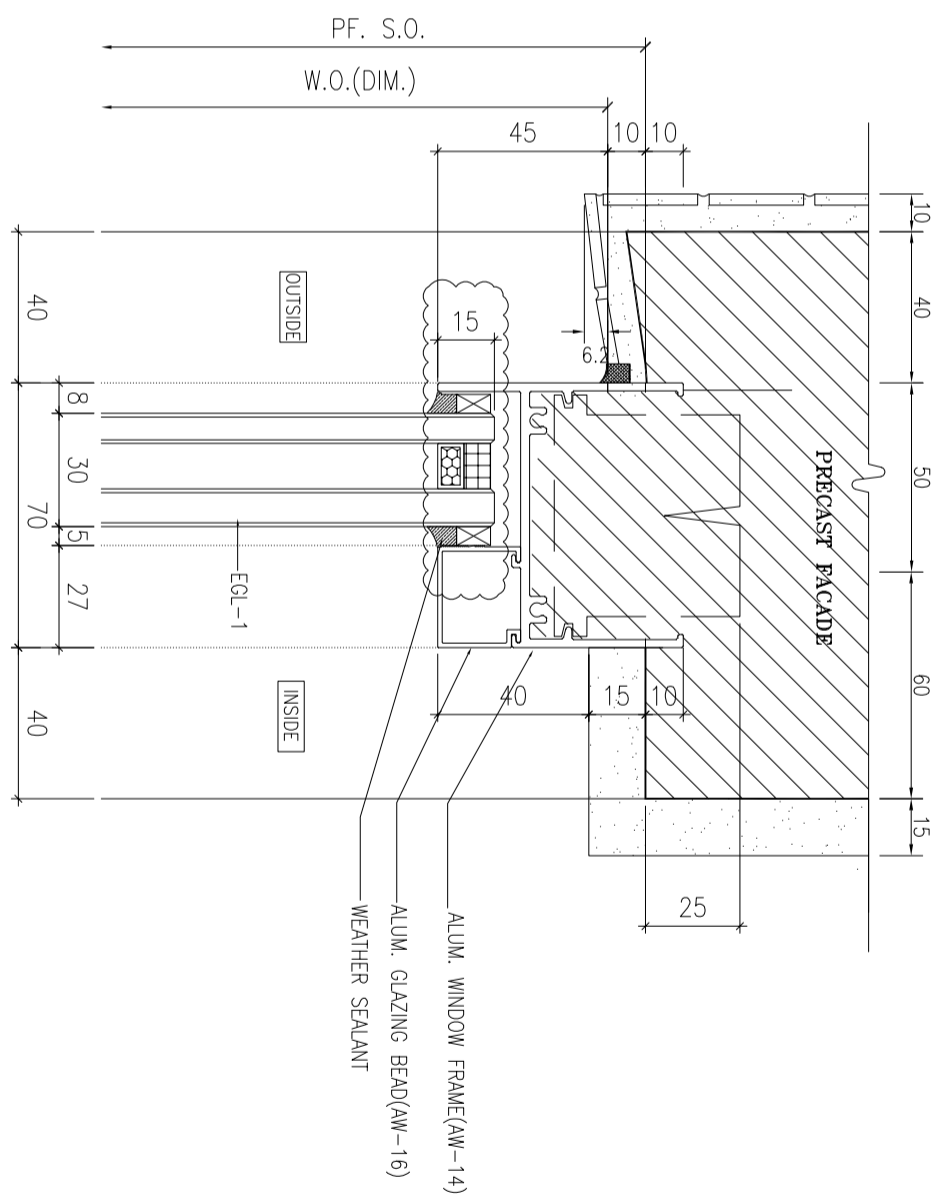

3 HORIZONTAL DETAIL  
SCALE 1:2

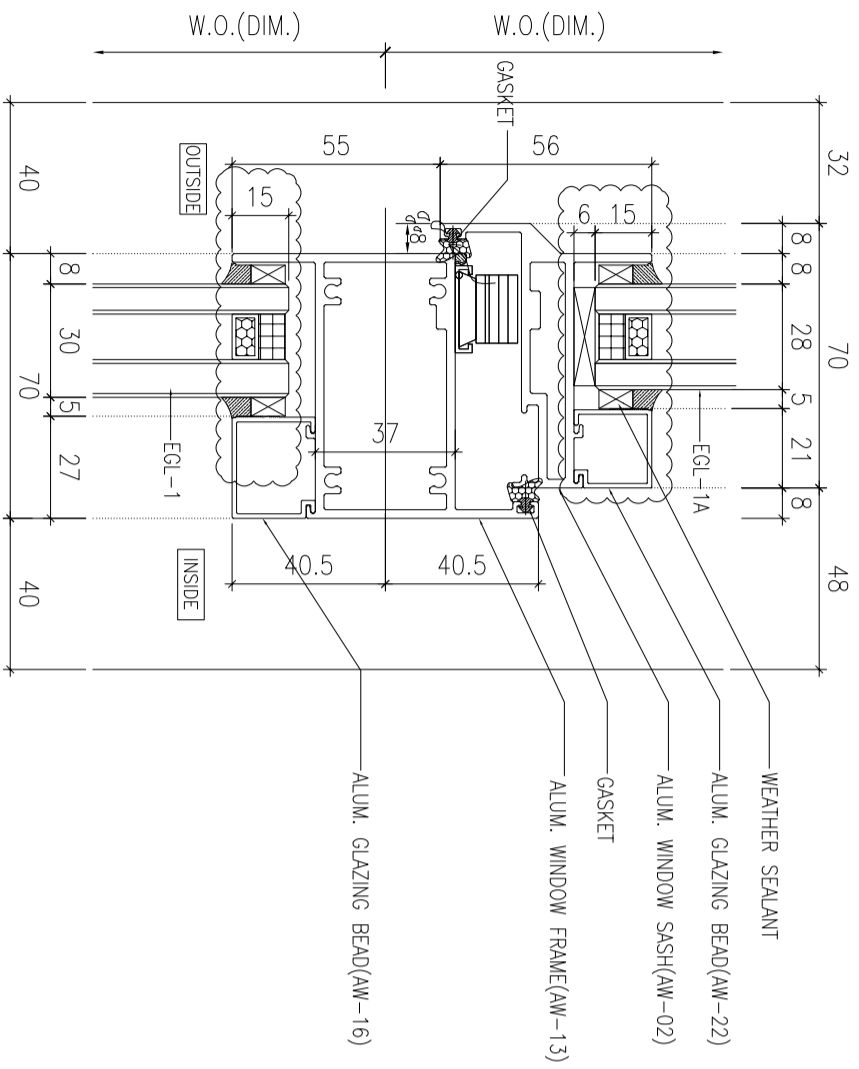

2 HORIZONTAL DETAIL  
SCALE 1:2

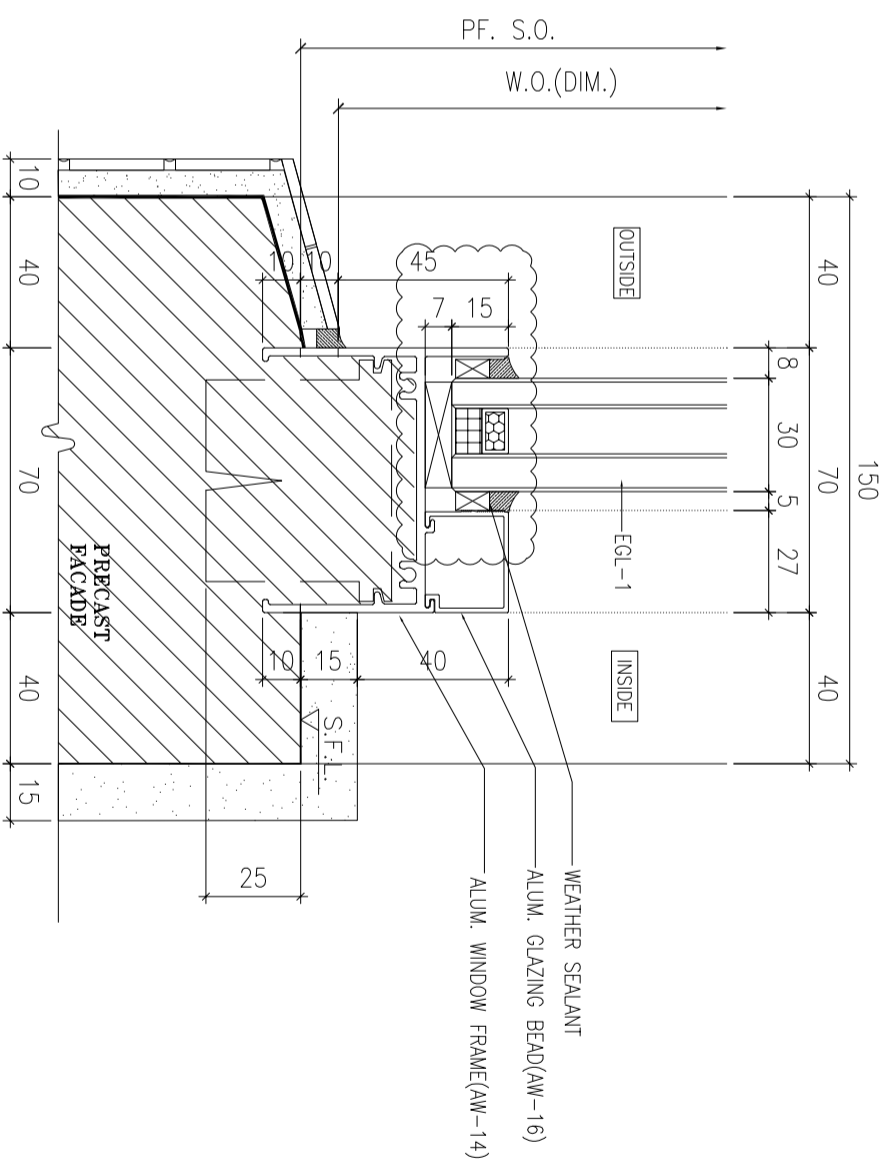

4 HORIZONTAL DETAIL  
SCALE 1:2

B.O. REF :

CLIENT :  
**SUN HUNG KAI**  
REAL ESTATE AGENCY LTD.  
42/F SUN HUNG KAI CENTRE, WANGCHAI, HONGKONG

ARCHITECT :  
**IWK&partners**  
a r c h i t e c t s

MAIN CONTRACTOR :  
**怡輝建築有限公司**  
Yee Fai Building Contractors Ltd.

STRUCTURAL ENGINEER :  
**ARUP**

FAÇADE CONSULTANT:  
**ALPHA CONSULTING LIMITED**  
Steel Structure & Façade Specialist

NOTE :  
1. ALL DIMENSIONS ARE IN mm.  
2. ALL ELEVATIONS ARE VIEWED FROM OUTSIDE.  
3. ALL DIMENSIONS TO BE VERIFIED ON SITE BEFORE FABRICATION.

LEGEND :  
X1 DETAIL MARK NO.  
X001 REFER SHEET NO.

1. F.F.L.--FINISHED FLOOR LEVEL
2. S.F.L.--STRUCTURAL FLOOR LEVEL
3. (R) --REVERSED DETAIL
4. GLASS LEGEND  
EQL-1--8mmHS+12mm AIR GAP+10mmTP THK. I.G.U.  
EQL-2--10mm THK. CLEAR TEMPERED GLASS  
EQL-4--10mm THK. TEMPERED ACID ETCHED GLASS  
EQL-1A--8mmHS+12mm AIR GAP+8mmTP THK. I.G.U.

NO.	DATE	REVISION SUBJECT TO ARCH/COMMENT	BY
A	30/10/2021	REVISION SUBJECT TO ARCH/COMMENT	YH
B	02/11/2021	REVISION SUBJECT TO ARCH/COMMENT	YH

JOB NO. : J-856

PROJECT :  
PROPOSED DEVELOPMENT ABOVE  
LIGHT RAIL TIN WING STOP TSWTL  
NO.23,AREA 33,TIN SHUI WAI, N.T.

TITLE :  
TYPICAL DETAILS FOR  
ALUM. WINDOW

DATE : 02-Aug-21 SCALE : 1:40

DRAWN BY : ivorn CHECKED BY :

**MIDI** ALUMINIUM FABRICATOR LTD.  
Units 6-8, Sunny Industrial Centre, 1/F  
610 Che Kwo Ling Road, Kowloon  
Tel:23489211-4 Fax:8522727666  
DWG NO. : J856-SD-PW-DT72 REV. : B

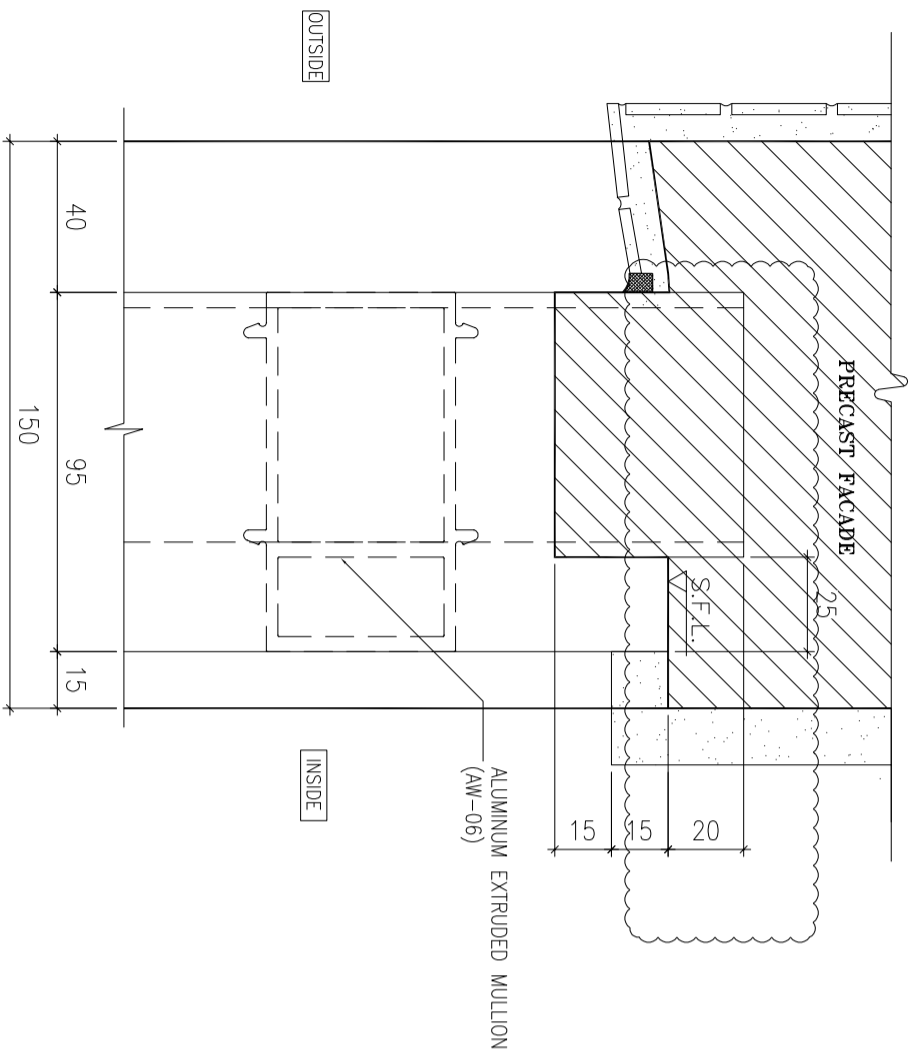

1 HORIZONTAL DETAIL  
SCALE 1:2

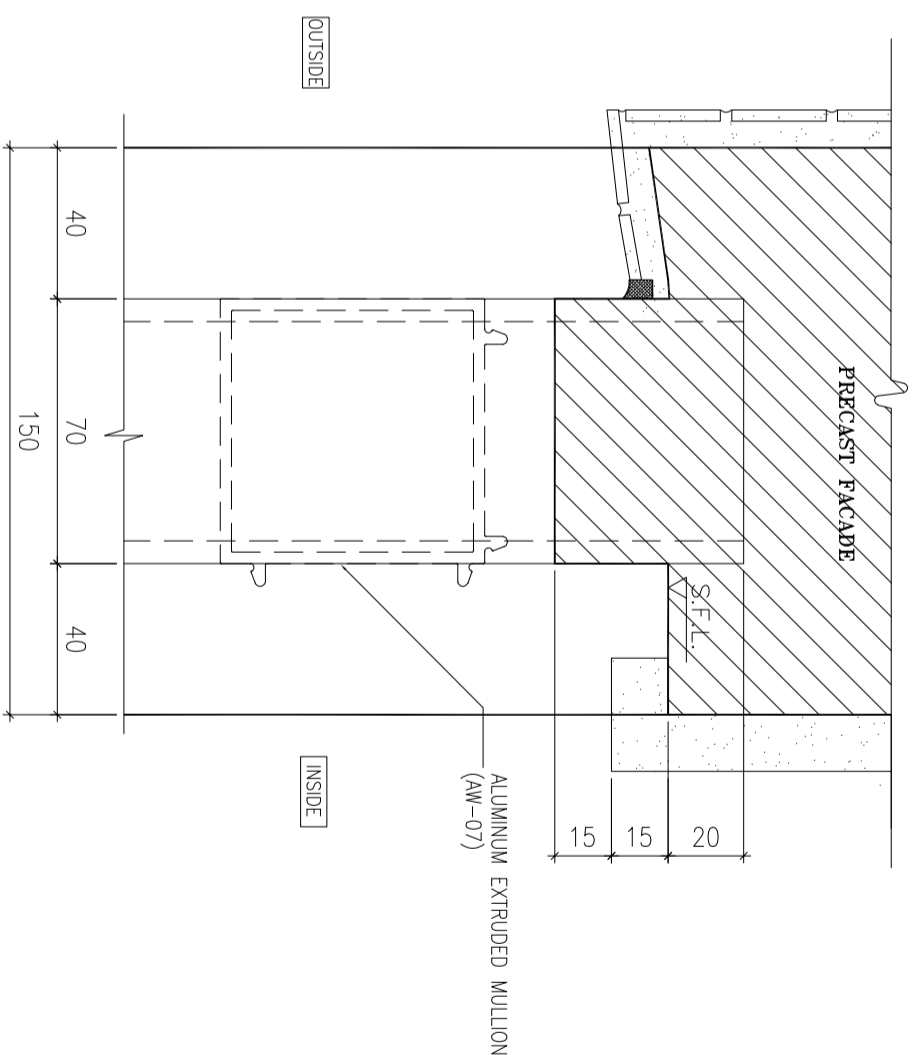

3 HORIZONTAL DETAIL  
SCALE 1:2

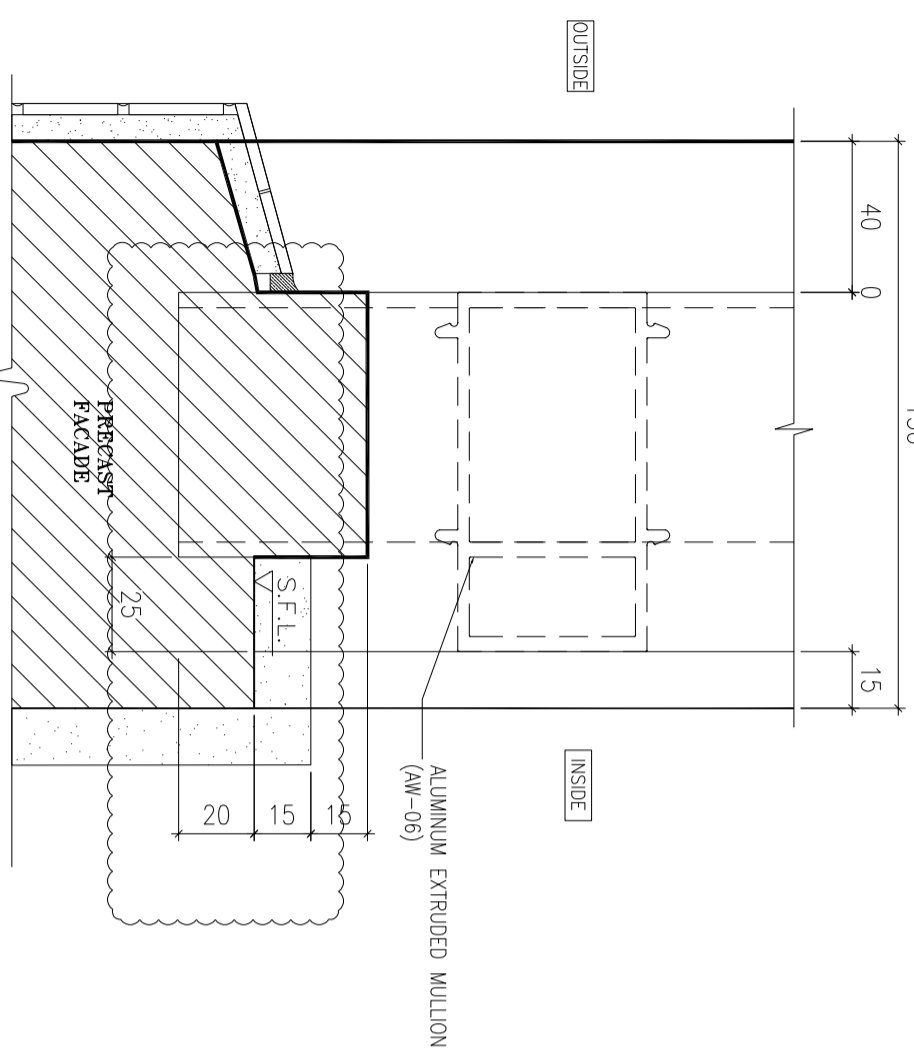

2 HORIZONTAL DETAIL  
SCALE 1:2

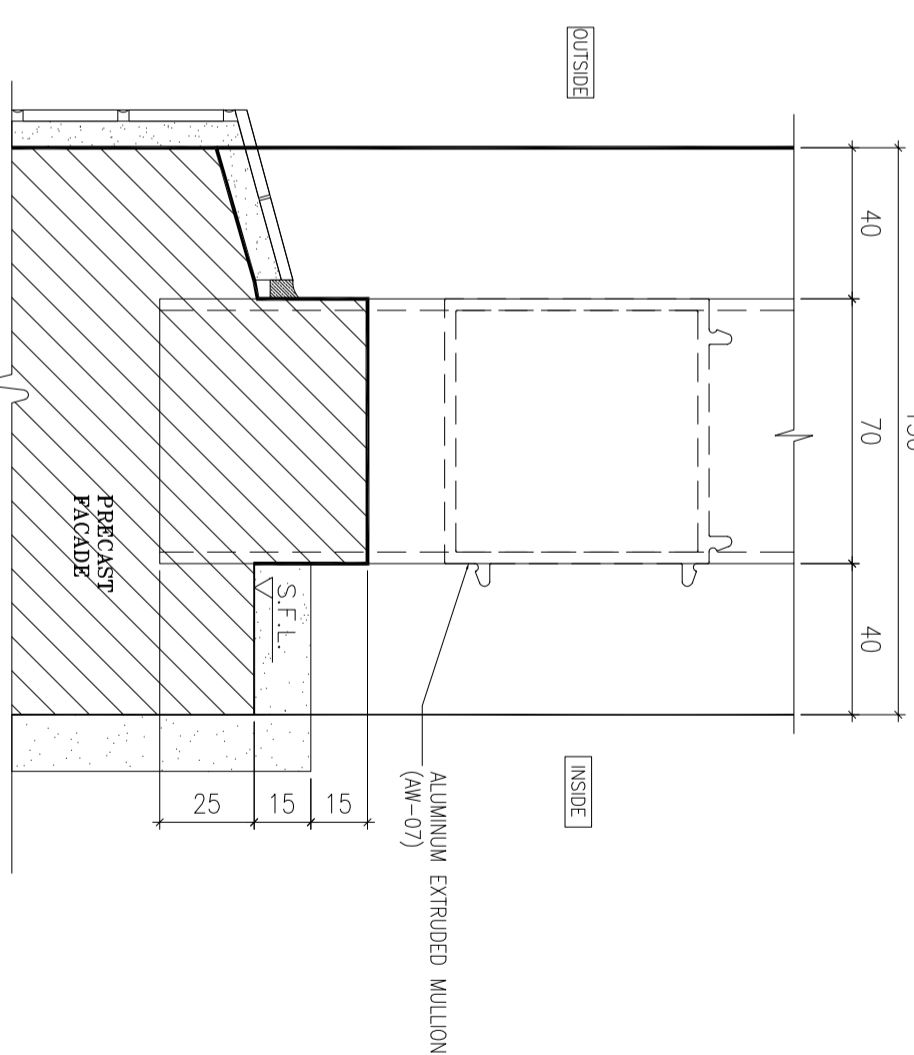

4 HORIZONTAL DETAIL  
SCALE 1:2

B.O. REF :

CLIENT :

**SUN HUNG KAI**  
REAL ESTATE AGENCY LTD.  
42/F SUN HUNG KAI CENTRE, WANGCHAI, HONGKONG

ARCHITECT :

**IWK&partners**  
a r c h i t e c t s

MAIN CONTRACTOR :

**怡輝建築有限公司**  
**Yee Fai Building Contractors Ltd.**

STRUCTURAL ENGINEER :

**ARUP**

FAÇADE CONSULTANT:

**ALPHA CONSULTING LIMITED**  
Steel Structure & Façade Specialist

NOTE :

1. ALL DIMENSIONS ARE IN mm.
2. ALL ELEVATIONS ARE VIEWED FROM OUTSIDE.
3. ALL DIMENSIONS TO BE VERIFIED ON SITE BEFORE FABRICATION.

LEGEND :

X1 DETAIL MARK NO.  
X001 REFER SHEET NO.

1. F.F.L.--FINISHED FLOOR LEVEL
2. S.F.L.--STRUCTURAL FLOOR LEVEL
3. (R) --REVERSED DETAIL

4. GLASS LEGEND

- EQ1-1--8mmHS+12mm AIR GAP+10mmTP THK. I.G.U.
- EQ1-2--10mm THK. CLEAR TEMPERED GLASS
- EQ1-4--10mm THK. TEMPERED ACID ETCHED GLASS
- EQ1-1A--8mmHS+12mm AIR GAP+8mmTP THK. I.G.U.

NO.	DATE	REVISION	REVISION SUBJECT TO ARCH/COMMENT	BY
C	02/11/2021	REVISION SUBJECT TO ARCH/COMMENT		ivan
B	30/09/2021	REVISION SUBJECT TO ARCH/COMMENT		ivan
A	30/09/2021	REVISION SUBJECT TO ARCH/COMMENT		ivan

JOB NO. : J-856

PROJECT : PROPOSED DEVELOPMENT ABOVE LIGHT RAIL TIN WING STOP TSWTL NO.23,AREA 33,TIN SHUI WAI, N.T.

TITLE : TYPICAL DETAILS FOR ALUM. WINDOW

DATE : 02-Aug-21 SCALE : 1:40  
DRAWN BY : ivan CHECKED BY :

**美特鋁質有限公司**  
**MIDI ALUMINIUM FABRICATOR LTD.**  
Units 6-8, Sunny Industrial Centre, 1/F  
610 Che Kwo Ling Road, Kowloon  
Tel:23489211-4 Fax:8522727666  
DWG NO. : J856-SD-PW-DT73 REV. : C

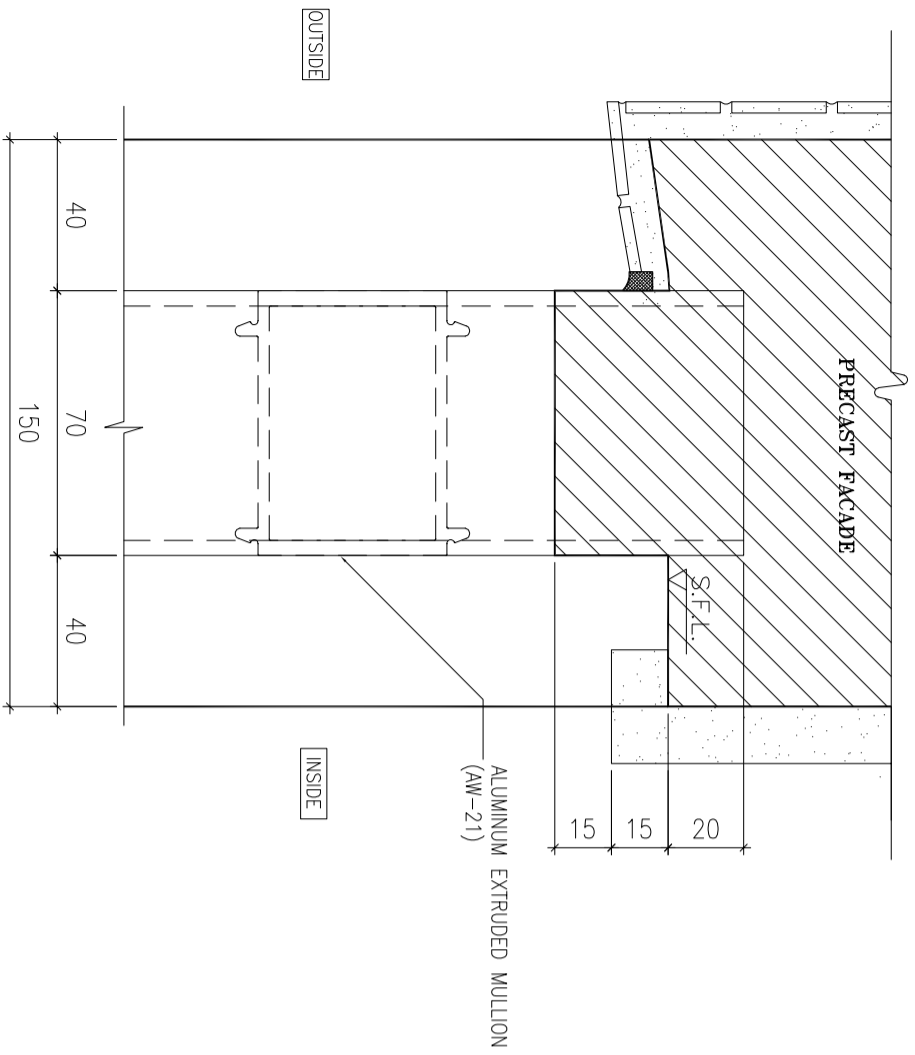

**1** HORIZONTAL DETAIL  
SCALE 1:2

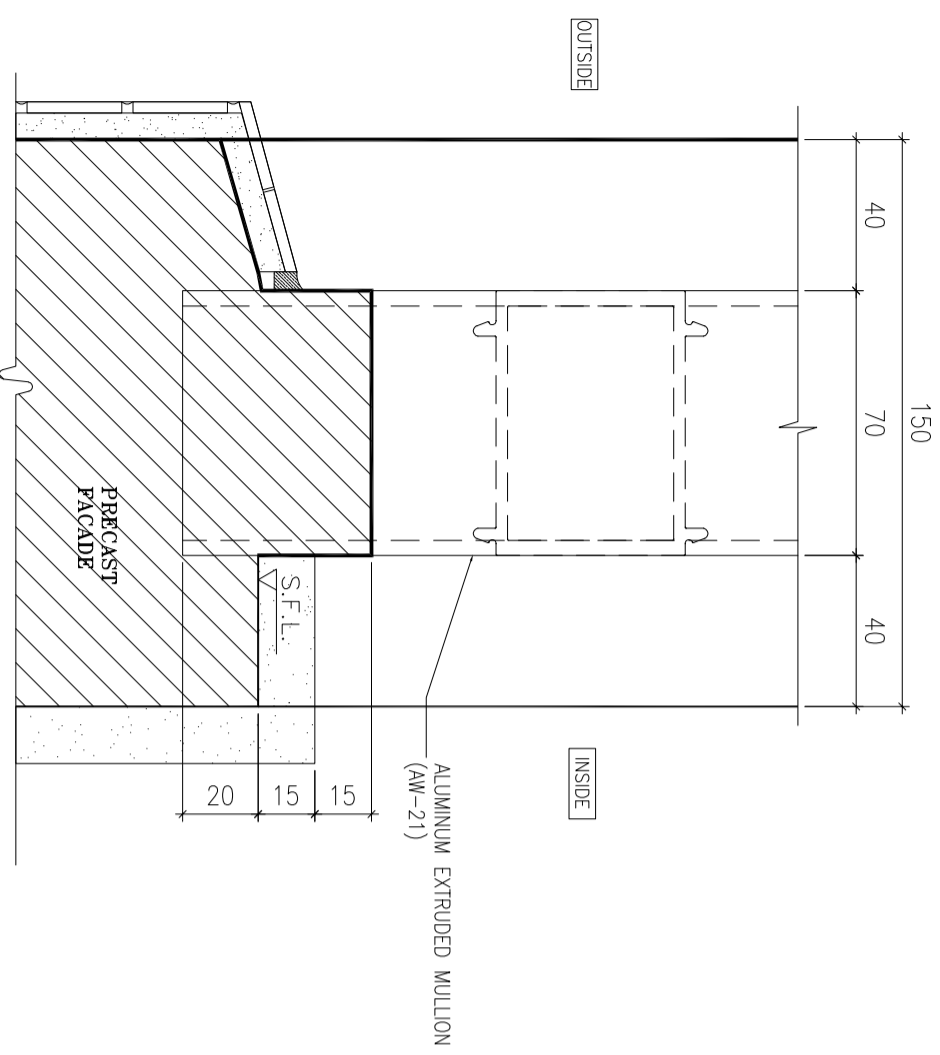

**2** HORIZONTAL DETAIL  
SCALE 1:2

B.O. REF :

CLIENT :

**SUN HUNG KAI**  
REAL ESTATE AGENCY LTD.  
42/F SUN HUNG KAI CENTRE, WANGCHAI, HONGKONG

ARCHITECT :

**lwk&partners**  
a r c h i t e c t s

MAIN CONTRACTOR :

**怡輝建築有限公司**  
**Yee Fai Building Contractors Ltd.**

STRUCTURAL ENGINEER :

**ARUP**  
FAÇADE CONSULTANT:

**ALPHA CONSULTING LIMITED**  
Steel Structure & Façade Specialist

NOTE :

1. ALL DIMENSIONS ARE IN mm.
2. ALL ELEVATIONS ARE VIEWED FROM OUTSIDE.
3. ALL DIMENSIONS TO BE VERIFIED ON SITE BEFORE FABRICATION.

LEGEND :

- (X1) DETAIL MARK NO.  
(X001) REFER SHEET NO.

1. F.F.L.--FINISHED FLOOR LEVEL
2. S.F.L.--STRUCTURAL FLOOR LEVEL
3. (R) --REVERSED DETAIL

4. GLASS LEGEND

- EQ1-1--8mmHS+12mm AIR GAP+10mmTP THK. I.G.U.  
EQ1-2--10mm THK. CLEAR TEMPERED GLASS  
EQ1-4--10mm THK. TEMPERED ACID ETCHED GLASS  
EQ1-1A--8mmHS+12mm AIR GAP+8mmTP THK. I.G.U.

NO.	DATE	REVISION	BY

JOB NO. : J-856

PROJECT :  
PROPOSED DEVELOPMENT ABOVE  
LIGHT RAIL TIN WING STOP TSWTL  
NO.23,AREA 33,TIN SHUI WAI, N.T.

TITLE :  
TYPICAL DETAILS FOR  
ALUM. WINDOW

DATE : 02-Aug-21 SCALE : 1:40

DRAWN BY : Ivorn CHECKED BY :

**美特鋁質有限公司**  
MIDI ALUMINIUM FABRICATOR LTD.  
Units 6-8, Sunny Industrial Centre, 1/F  
610 Che Kwo Ling Road, Kowloon  
Tel:23489211-4 Fax:8522727666  
DWG NO. : JB56-SD-PW-DT73a REV. : -

B.O. REF :

CLIENT :

**SUN HUNG KAI**  
REAL ESTATE AGENCY LTD.  
42/F SUN HUNG KAI CENTRE, WANGCHAI, HONGKONG

ARCHITECT :

**lwk&partners**  
a r c h i t e c t s

MAIN CONTRACTOR :

**怡輝建築有限公司**  
Yee Fai Building Contractors Ltd.

STRUCTURAL ENGINEER :

**ARUP**

FAÇADE CONSULTANT:

**ALPHA CONSULTING LIMITED**  
Steel Structure & Façade Specialist

NOTE :

1. ALL DIMENSIONS ARE IN mm.
2. ALL ELEVATIONS ARE VIEWED FROM OUTSIDE.
3. ALL DIMENSIONS TO BE VERIFIED ON SITE BEFORE FABRICATION.

LEGEND :

X1 --- DETAIL MARK NO.  
X001 --- REFER SHEET NO.

1. F.F.L. --- FINISHED FLOOR LEVEL
2. S.F.L. --- STRUCTURAL FLOOR LEVEL
3. (R) --- REVERSED DETAIL

4. GLASS LEGEND

EQ1-1 --- 6mmHS+12mm AIR GAP+10mmTP THK. I.G.U.  
 EQ1-2 --- 10mm THK. CLEAR TEMPERED GLASS  
 EQ1-4 --- 10mm THK. TEMPERED ACID ETCHED GLASS  
 EQ1-1A --- 6mmHS+12mm AIR GAP+8mmTP THK. I.G.U.

NO.	DATE	REVISION	BY

JOB NO. : J-856

PROJECT : PROPOSED DEVELOPMENT ABOVE LIGHT RAIL TIN WING STOP TSWTL NO.23,AREA 33,TIN SHUI WAI, N.T.

TITLE : ALUM. WINDOW SECTION TYPICAL LOCK & HINGES DETAIL

DATE : 02-Aug-21 SCALE : 1:40

DRAWN BY : Ivorn CHECKED BY :

**美特鋁質有限公司**  
MIDI ALUMINIUM FABRICATOR LTD.  
Units 6-8, Sunny Industrial Centre, 1/F  
610 Che Kwo Ling Road, Kowloon  
Tel:23489211-4 Fax:8522727666

DWG NO. : J856-SD-PW-DT74

REV. : -

# 70窗

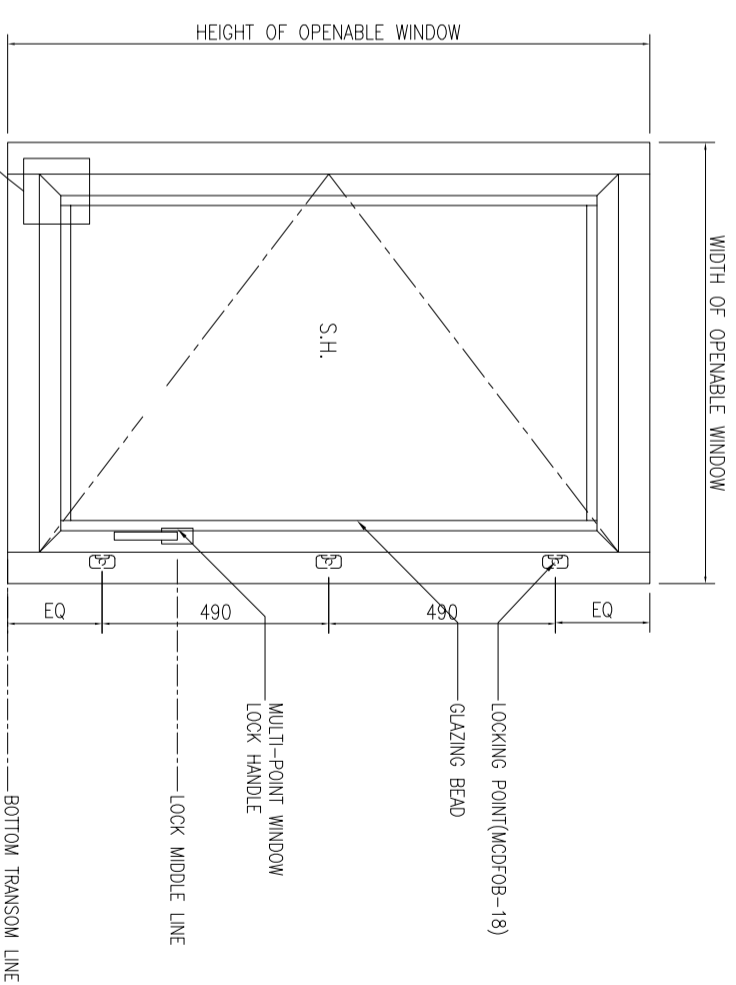
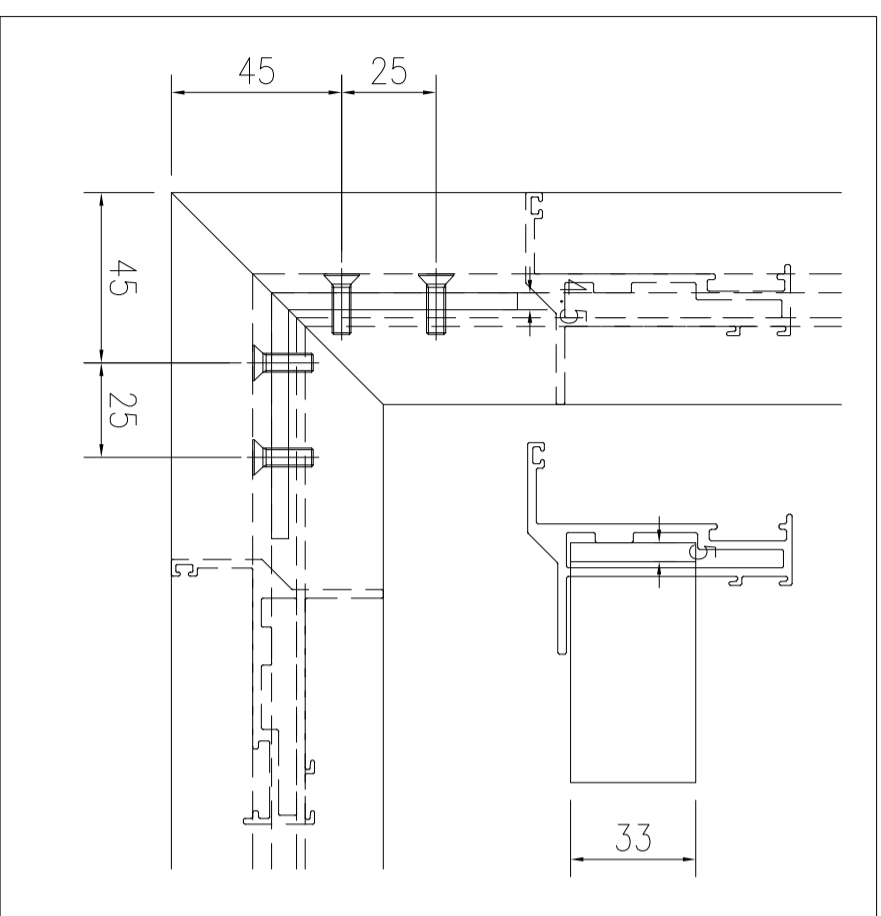

01 TYPICAL SECTION

S.F.L.

B.O. REF :

CLIENT :

**SUN HUNG KAI**  
REAL ESTATE AGENCY LTD.  
42/F SUN HUNG KAI CENTRE, WANGCHAI, HONGKONG

ARCHITECT :

**lwk&partners**  
a r c h i t e c t s

MAIN CONTRACTOR :

**怡輝建築有限公司**  
Yee Fai Building Contractors Ltd.

STRUCTURAL ENGINEER :

**ARUP**

FAÇADE CONSULTANT:

**ALPHA CONSULTING LIMITED**  
Steel Structure & Façade Specialist

NOTE :

1. ALL DIMENSIONS ARE IN mm.
2. ALL ELEVATIONS ARE VIEWED FROM OUTSIDE.
3. ALL DIMENSIONS TO BE VERIFIED ON SITE BEFORE FABRICATION.

LEGEND :

X1 --- DETAIL MARK NO.  
X001 --- REFER SHEET NO.

1. F.F.L. --- FINISHED FLOOR LEVEL
2. S.F.L. --- STRUCTURAL FLOOR LEVEL
3. (R) --- REVERSED DETAIL

4. GLASS LEGEND

- EQ1-1 --- 8mmHS+12mm AIR GAP+10mmTP THK. I.G.U.  
EQ1-2 --- 10mm THK. CLEAR TEMPERED GLASS  
EQ1-4 --- 10mm THK. TEMPERED ACID ETCHED GLASS  
EQ1-1A --- 8mmHS+12mm AIR GAP+8mmTP THK. I.G.U.

NO.	DATE	REVISION	BY

JOB NO. : J-856

PROJECT :  
PROPOSED DEVELOPMENT ABOVE  
LIGHT RAIL TIN WING STOP TSWTL  
NO.23,AREA 33,TIN SHUI WAI, N.T.

TITLE :

ALUM. WINDOW SECTION  
TYPICAL LOCK & HINGES DETAIL

DATE : 02-Aug-21 SCALE : 1:40

DRAWN BY : Ivorn CHECKED BY :

**美特鋁質有限公司**  
MIDI ALUMINIUM FABRICATOR LTD.  
Units 6-8, Sunny Industrial Centre, 1/F  
610 Che Kwo Ling Road, Kowloon  
Tel:23489211-4 Fax:8522727666

DWG NO. : J856-SD-PW-DT74d REV. : -

# 50窗

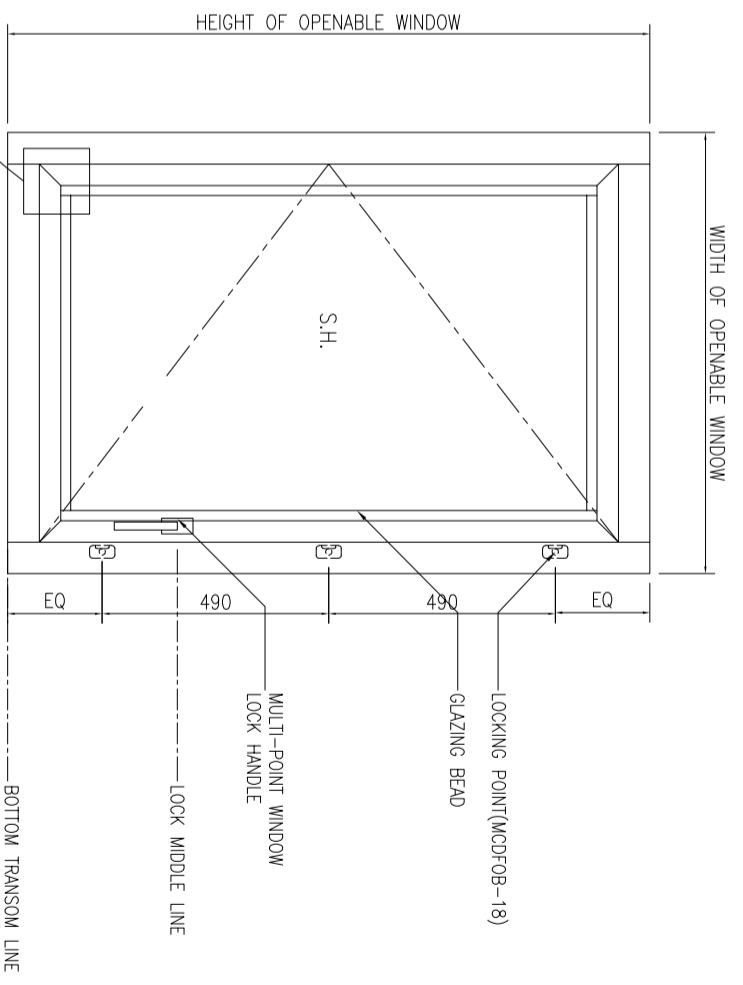
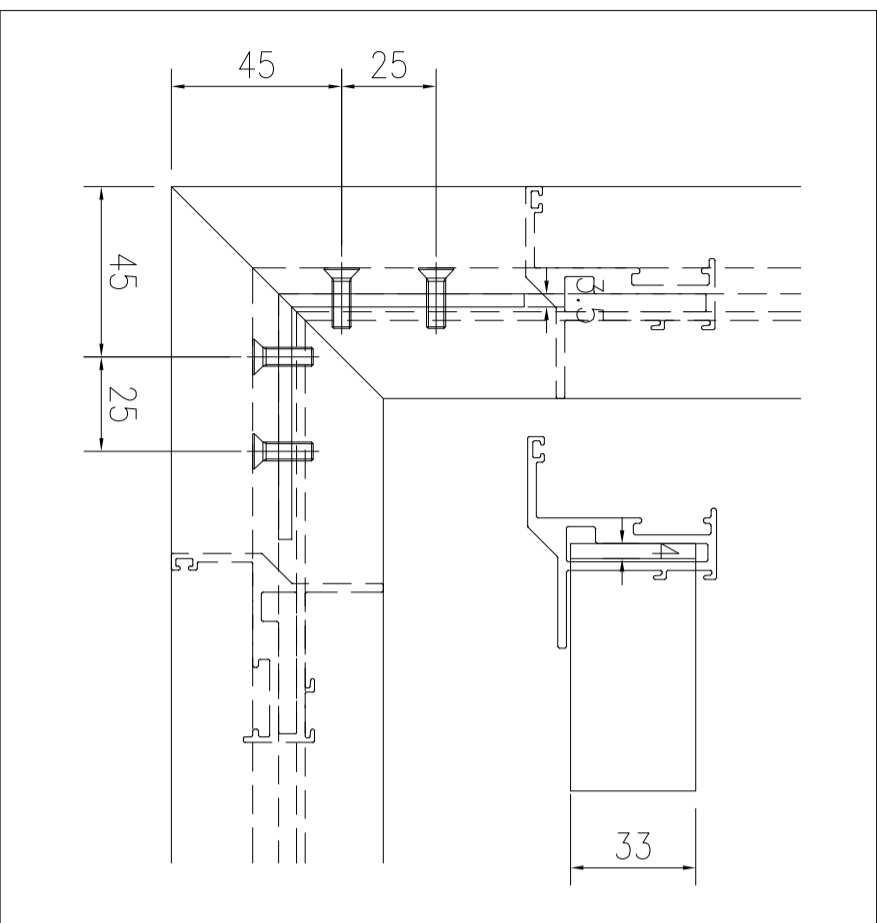

01 TYPICAL SECTION

S.F.L.

B.O. REF :

CLIENT :

**SUN HUNG KAI**  
REAL ESTATE AGENCY LTD.  
42/F SUN HUNG KAI CENTRE, WANGCHAI, HONGKONG

ARCHITECT :

**IWK&partners**  
a r c h i t e c t s

MAIN CONTRACTOR :

**怡輝建築有限公司**  
Yee Fai Building Contractors Ltd.

STRUCTURAL ENGINEER :

**ARUP**

FAÇADE CONSULTANT:

**ALPHA CONSULTING LIMITED**  
Steel Structure & Façade Specialist

NOTE :

1. ALL DIMENSIONS ARE IN mm.
2. ALL ELEVATIONS ARE VIEWED FROM OUTSIDE.
3. ALL DIMENSIONS TO BE VERIFIED ON SITE BEFORE FABRICATION.

LEGEND :

X1 ——— DETAIL MARK NO.  
X001 ——— REFER SHEET NO.

1. F.F.L. -- FINISHED FLOOR LEVEL
2. S.F.L. -- STRUCTURAL FLOOR LEVEL
3. (R) -- REVERSED DETAIL
4. GLASS LEGEND

EGL-1 -- 6mmHS+12mm AIR GAP+10mmTP THK. I.G.U.  
 EGL-2 -- 10mm THK. CLEAR TEMPERED GLASS  
 EGL-4 -- 10mm THK. TEMPERED ACID ETCHED GLASS  
 EGL-1A -- 8mmHS+12mm AIR GAP+8mmTP THK. I.G.U.

NO.	DATE	REVISION	BY

JOB NO. : J-856

PROJECT :  
 PROPOSED DEVELOPMENT ABOVE  
 LIGHT RAIL TIN WING STOP TSWTL  
 NO.23, AREA 33, TIN SHUI WAI, N.T.

TITLE :  
 G.M.S FIXING LUG TYPICAL DETAIL  
 FOR ALUM. WINDOW

DATE : 02-Aug-21 SCALE : 1:60  
 DRAWN BY : ivon CHECKED BY :

**美特鋁質有限公司**  
 MIDI ALUMINIUM FABRICATOR LTD.  
 Units 6-8, Sunny Industrial Centre, 1/F  
 610 Che Kwo Ling Road, Kowloon  
 Tel:23489211-4 Fax:8522727666  
 DWG NO. : J856-SD-PW-DT75 REV. : -

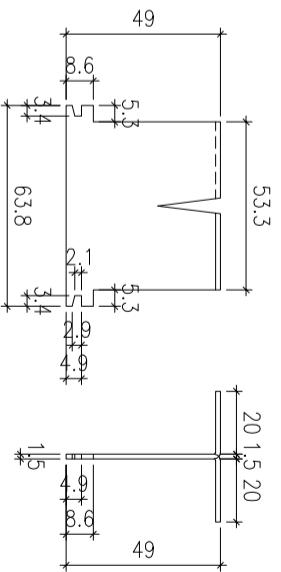
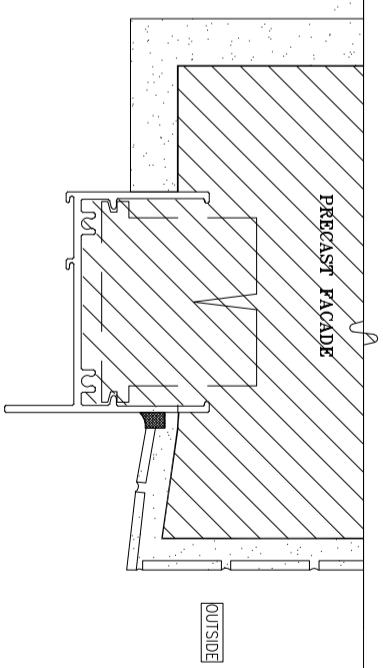
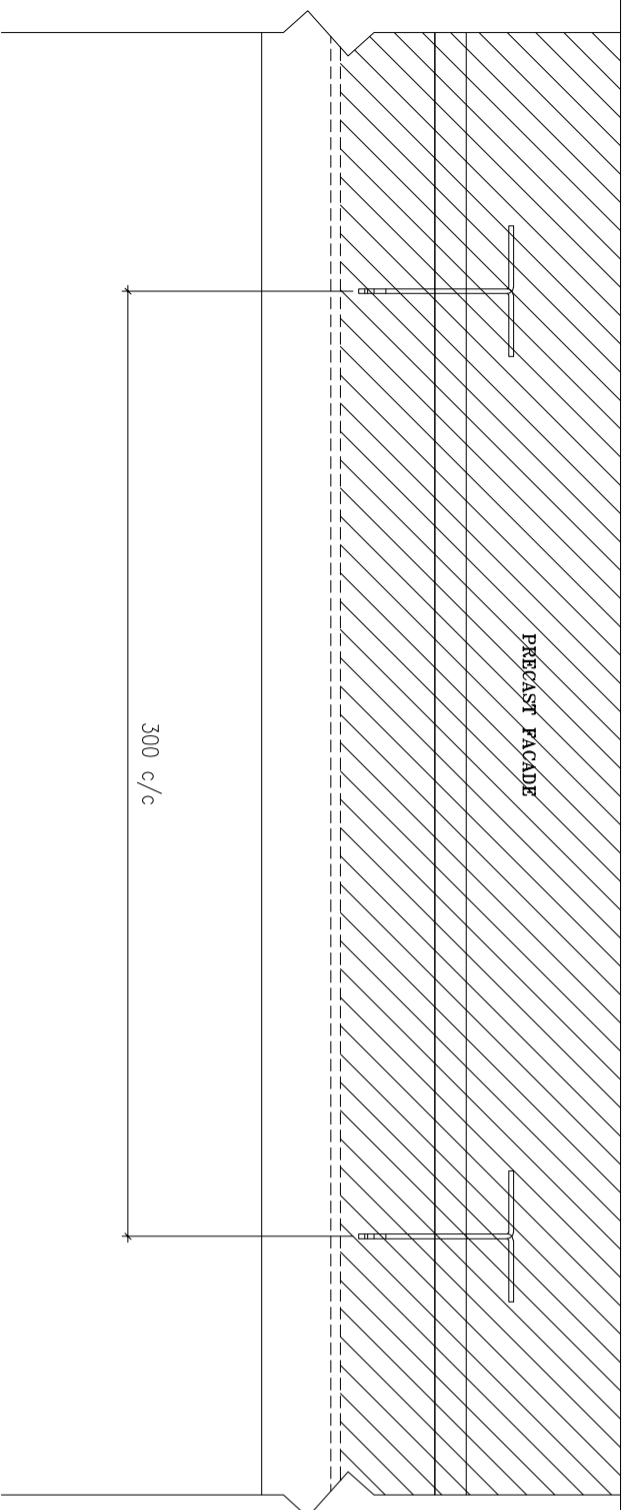

1 HORIZONTAL DETAIL  
SCALE 1:2

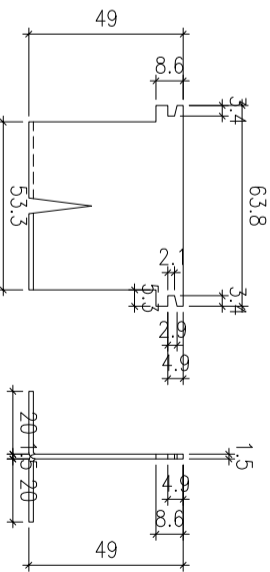

2 HORIZONTAL DETAIL  
SCALE 1:2

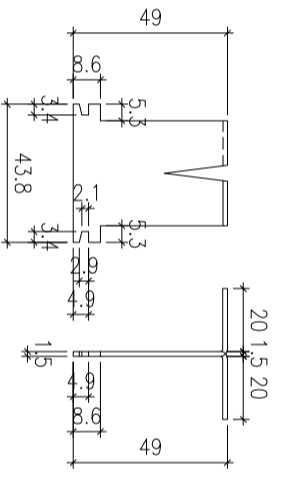

3 HORIZONTAL DETAIL  
SCALE 1:2

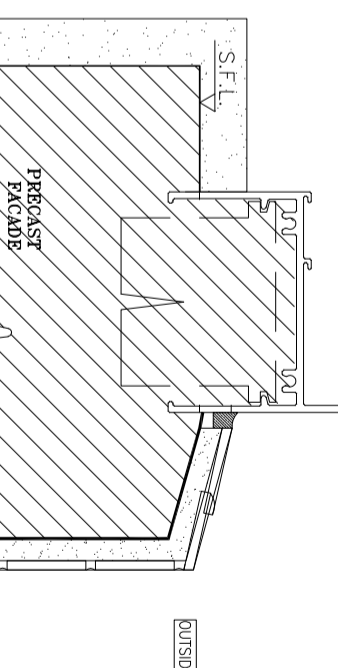
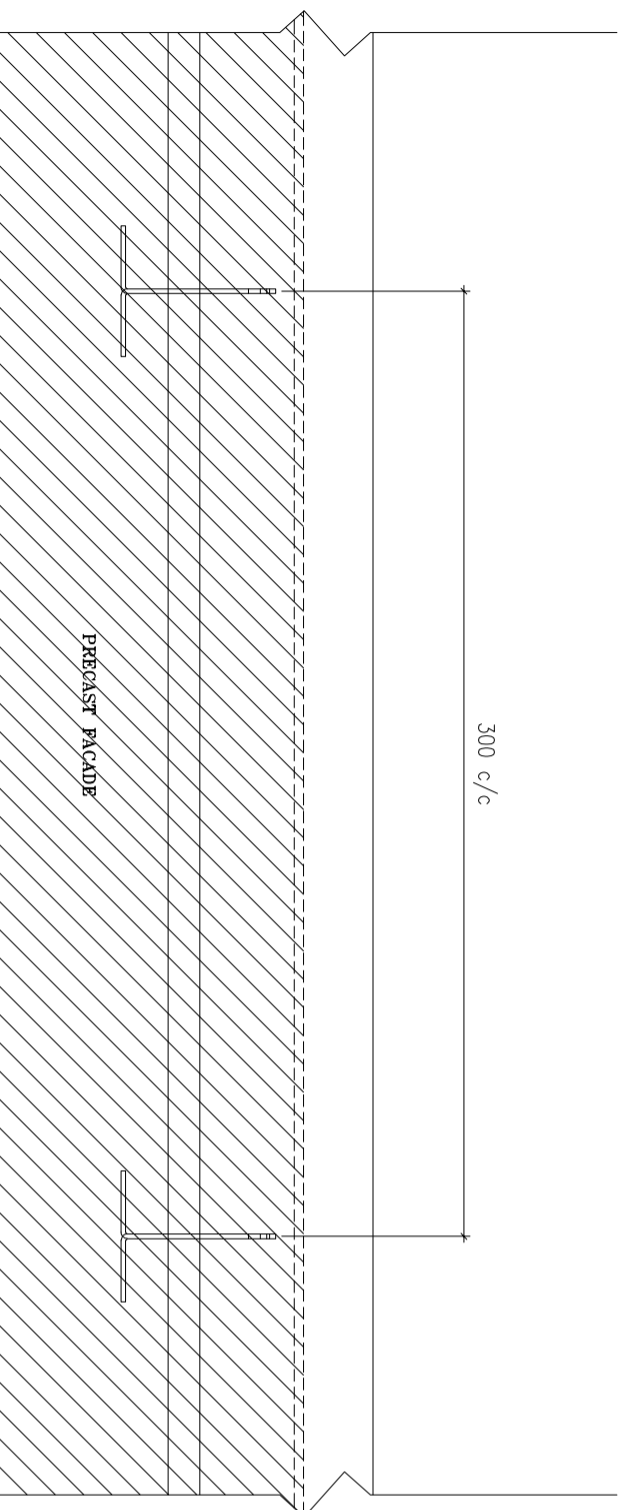

B.O. REF :

CLIENT :

**SUN HUNG KAI**  
REAL ESTATE AGENCY LTD.  
42/F SUN HUNG KAI CENTRE, WANGCHAI, HONGKONG

ARCHITECT :

**lwk&partners**  
a r c h i t e c t s

MAIN CONTRACTOR :

**怡輝建築有限公司**  
Yee Fai Building Contractors Ltd.

STRUCTURAL ENGINEER :

**ARUP**  
FAÇADE CONSULTANT:

**ALPHA CONSULTING LIMITED**  
Steel Structure & Façade Specialist

NOTE :

1. ALL DIMENSIONS ARE IN mm.
2. ALL ELEVATIONS ARE VIEWED FROM OUTSIDE.
3. ALL DIMENSIONS TO BE VERIFIED ON SITE BEFORE FABRICATION.

LEGEND :

X1 --- DETAIL MARK NO.  
X001 --- REFER SHEET NO.

1. F.F.L.--FINISHED FLOOR LEVEL
2. S.F.L.--STRUCTURAL FLOOR LEVEL
3. (R) --REVERSED DETAIL

4. GLASS LEGEND

EQ1-1--8mmHS+12mm AIR GAP+10mmTP THK. I.G.U.  
EQ1-2--10mm THK. CLEAR TEMPERED GLASS  
EQ1-4--10mm THK. TEMPERED ACID ETCHED GLASS  
EQ1-1A--8mmHS+12mm AIR GAP+8mmTP THK. I.G.U.

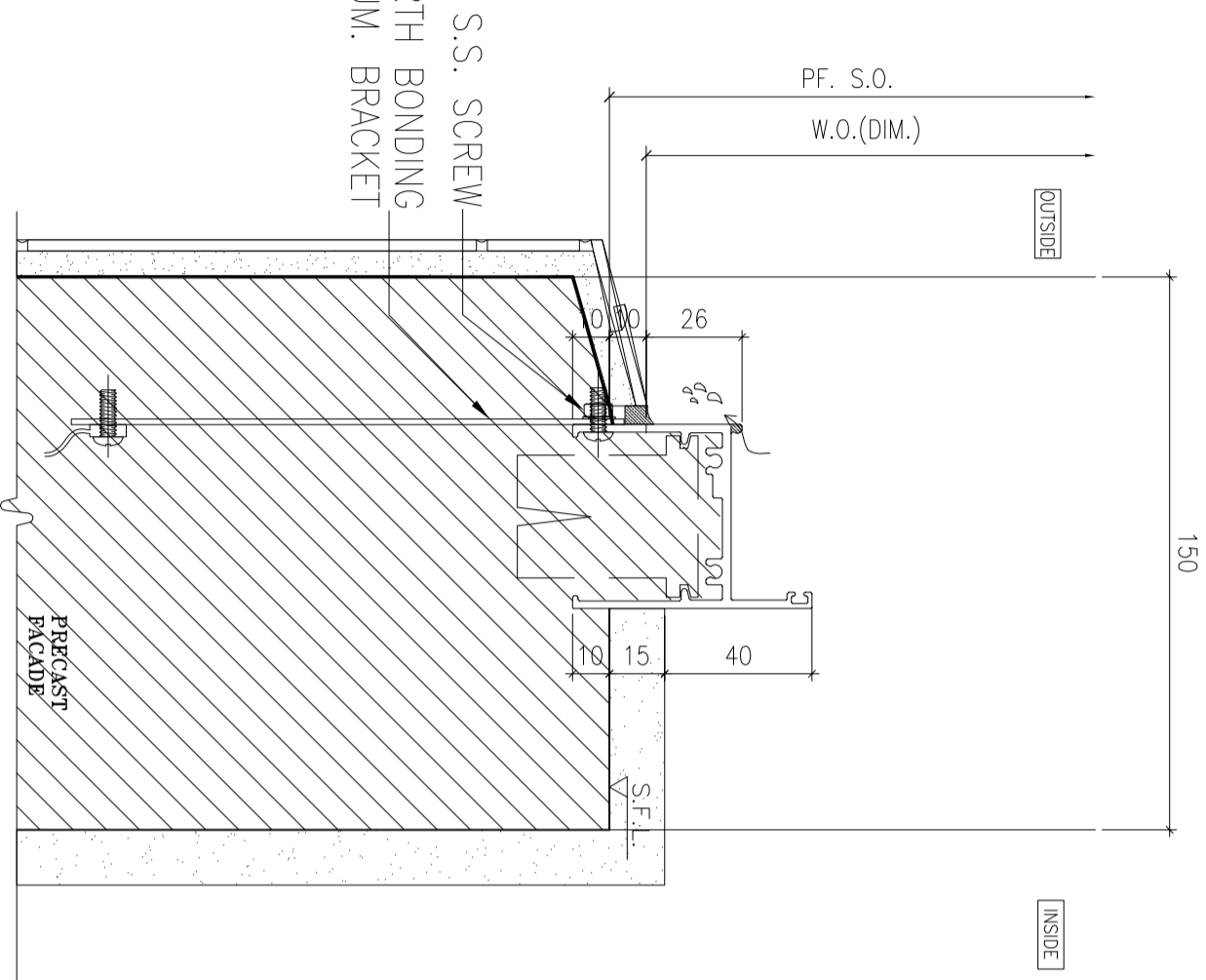

**1** HORIZONTAL DETAIL  
SCALE 1:2

TITLE :  
TYPICAL EARTHING  
BONDING DETAILS OF PRECAST

DATE : 02-Aug-21 SCALE : 1:40

DRAWN BY : Ivorn CHECKED BY :

**美特鋁質有限公司**  
MIDI ALUMINIUM FABRICATOR LTD.  
Units 6-8, Sunny Industrial Centre, 1/F  
610 Che Kwo Ling Road, Kowloon  
Tel:23489211-4 Fax:8522727666  
DWG NO. : JB56-SD-PW-DT76 REV. : -

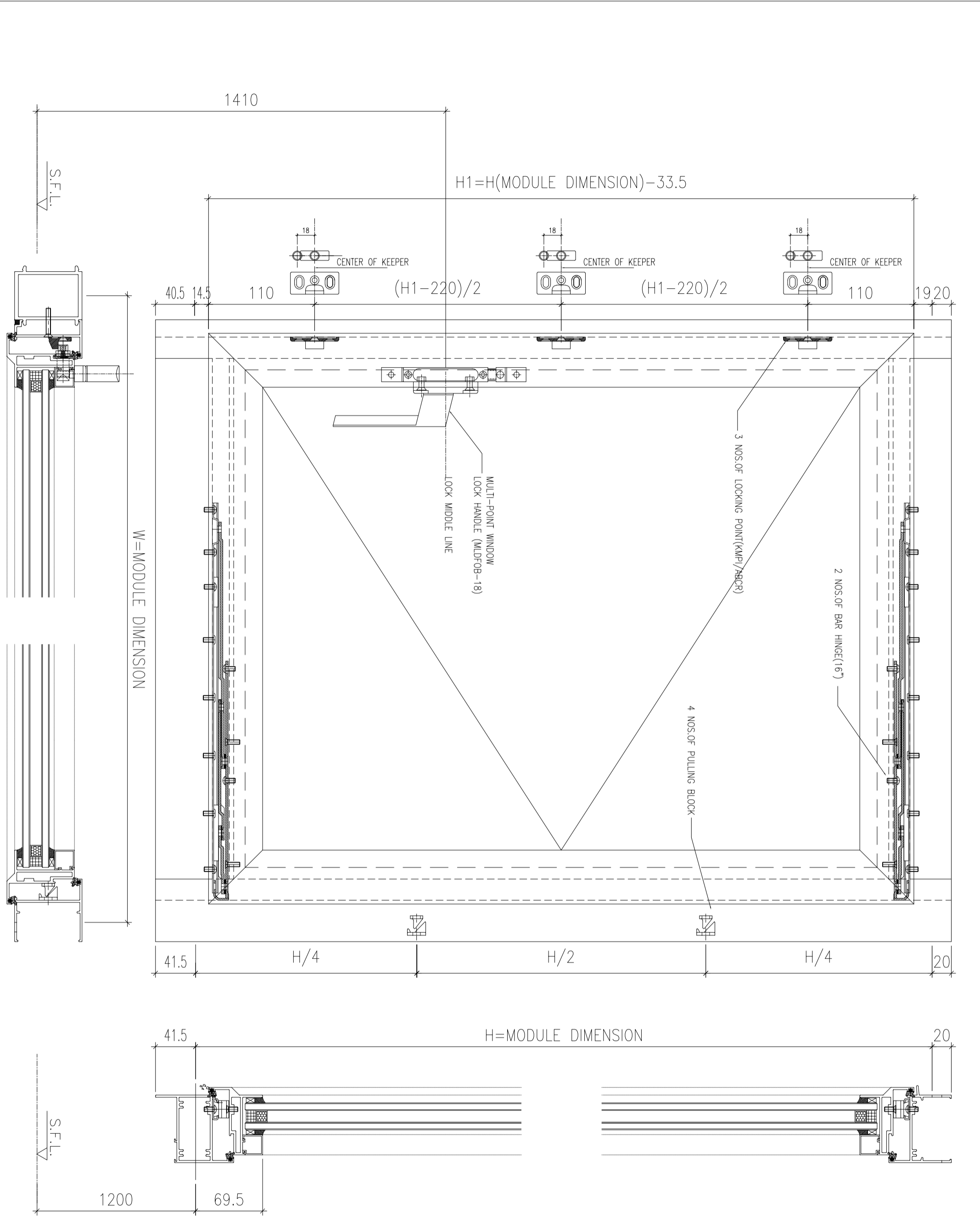

B.O. REF. : . . . . .

CLIENT :  
**SUN HUNG KAI**  
**REAL ESTATE AGENCY LTD.**  
 42/F SUN HUNG KAI CENTRE, WANGCHAI, HONGKONG

ARCHITECT :  
**lwk&partners**  
 a r c h i t e c t s

MAIN CONTRACTOR :  
**怡輝建築有限公司**  
**Yee Fai Building Contractors Ltd.**

STRUCTURAL ENGINEER :  
**ARUP**

FAÇADE CONSULTANT:  
**ALPHA CONSULTING LIMITED**  
 Steel Structure & Façade Specialist

NOTE :  
 1. ALL DIMENSIONS ARE IN mm.  
 2. ALL ELEVATIONS ARE VIEWED FROM OUTSIDE.  
 3. ALL DIMENSIONS TO BE VERIFIED ON SITE BEFORE FABRICATION.

LEGEND :  
 X1 --- DETAIL MARK NO.  
 X001 --- REFER SHEET NO.

1. F.F.L. -- FINISHED FLOOR LEVEL
2. S.F.L. -- STRUCTURAL FLOOR LEVEL
3. (R) -- REVERSED DETAIL
4. GLASS LEGEND  
 EG1-1 -- 8mmHS+12mm AIR GAP+10mmTP THK. I.G.U.  
 EG1-2 -- 10mm THK. CLEAR TEMPERED GLASS  
 EG1-4 -- 10mm THK. TEMPERED ACID ETCHED GLASS  
 EG1-1A -- 8mmHS+12mm AIR GAP+8mmTP THK. I.G.U.

NO.	DATE	REVISION	BY
JOB NO. :	J-856		

PROJECT :  
 PROPOSED DEVELOPMENT ABOVE  
 LIGHT RAIL TIN WING STOP TSWTL  
 NO.23, AREA 33, TIN SHUI WAI, N.T.

TITLE :  
 TYPICAL EARTHING  
 BONDING DETAILS OF PRECAST

DATE : 02-Aug-21 SCALE : 1:60  
 DRAWN BY : Ivorn CHECKED BY :

**美特鋁質有限公司**  
**MIDI ALUMINIUM FABRICATOR LTD.**  
 Units 6-8, Sunny Industrial Centre, 1/F  
 610 Che Kwo Ling Road, Kowloon  
 Tel:23489211-4 Fax:8522727666  
 DWG NO. : JB56-SD-PW-D1777 REV. : -

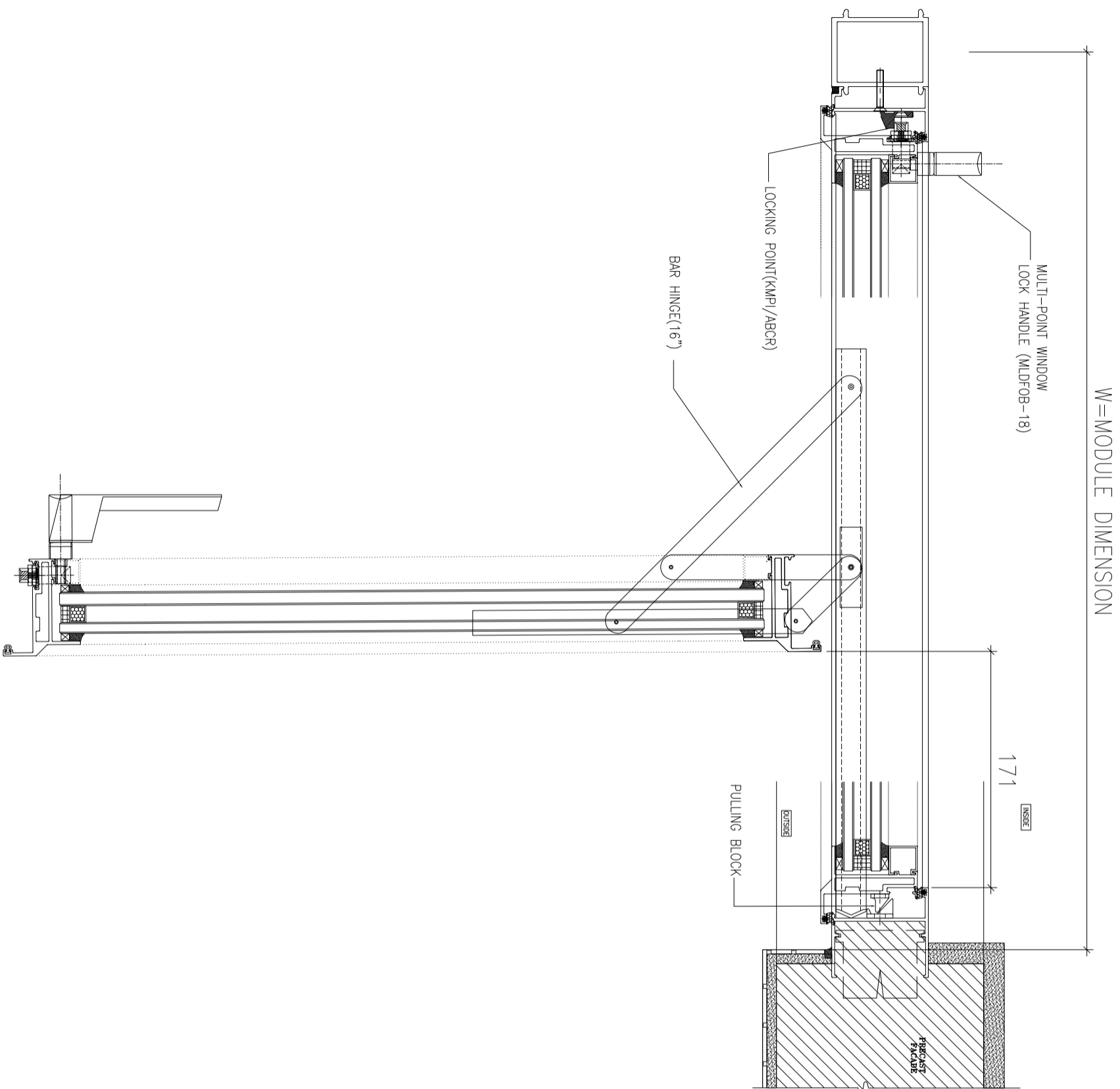

W=MODULE DIMENSION

MULTI-POINT WINDOW  
LOCK HANDLE (MLDFOB-18)

LOCKING POINT(KMP/ABCR)

BAR HINGE(16")

171

INSIDE

OUTSIDE

PULLING BLOCK

PRECAST  
CONCRETE

B.O. REF :

CLIENT :

**SUN HUNG KAI**  
REAL ESTATE AGENCY LTD.  
42/F SUN HUNG KAI CENTRE, WANCHAI, HONGKONG

ARCHITECT :

**lwk&partners**  
a r c h i t e c t s

MAIN CONTRACTOR :

**怡輝建築有限公司**  
**Yee Fai Building Contractors Ltd.**

STRUCTURAL ENGINEER :

**ARUP**

FAÇADE CONSULTANT:

**ALPHA CONSULTING LIMITED**  
Steel Structure & Façade Specialist

NOTE :

1. ALL DIMENSIONS ARE IN mm.
2. ALL ELEVATIONS ARE VIEWED FROM OUTSIDE.
3. ALL DIMENSIONS TO BE VERIFIED ON SITE BEFORE FABRICATION.

LEGEND :

X1 ——— DETAIL MARK NO.  
X001 ——— REFER SHEET NO.

1. F.F.L.--FINISHED FLOOR LEVEL
2. S.F.L.--STRUCTURAL FLOOR LEVEL
3. (R) --REVERSED DETAIL

4. GLASS LEGEND

- EGL-1--8mmHS+12mm AIR GAP+10mmTP THK. I.G.U.  
EGL-2--10mm THK. CLEAR TEMPERED GLASS  
EGL-4--10mm THK. TEMPERED ACID ETCHED GLASS  
EGL-1A--8mmHS+12mm AIR GAP+8mmTP THK. I.G.U.

NO.	DATE	REVISION	BY

JOB NO. : J-856

PROJECT :  
PROPOSED DEVELOPMENT ABOVE  
LIGHT RAIL TIN WING STOP TSWTL  
NO.23,AREA 33,TIN SHUI WAI, N.T.

TITLE :  
TYPICAL EARTHING  
BONDING DETAILS OF PRECAST

DATE : 02-Aug-21 SCALE : 1:60

DRAWN BY : Ivorn CHECKED BY :

**美特鋁質有限公司**  
MIDI ALUMINIUM FABRICATOR LTD.  
Units 6-8, Sunny Industrial Centre, 1/F  
610 Cho Kwo Ling Road, Kowloon  
Tel:23489211-4 Fax:85272727666

DWG NO. : J856-SD-PW-DT78

REV. : -