

工程指示 / 要求簡箋(E.I.)

工程指示編號：EI / 3986 / 21

修改版次：C

工程編號：J - 856

工程名稱：天水圍天榮站

工程項目：佛沙窗 大圖( 6th 大圖 )

收件人：生統 / 謝永林 / 王良 發件人：Eric Liu

日期：01/12/2021

要求提供 / 確認 事項：

- |                                    |                                     |                               |
|------------------------------------|-------------------------------------|-------------------------------|
| <input type="checkbox"/> 初步鋁料 B.M. | <input type="checkbox"/> 加工拆圖，然後生產  | <input type="checkbox"/> 尺寸表  |
| <input type="checkbox"/> 正式鋁料 B.M. | <input type="checkbox"/> 技術上資料 / 指示 | <input type="checkbox"/> 報價   |
| <input type="checkbox"/> 配件 B.M.   | <input type="checkbox"/> 樣辦或貨品說明書   | <input type="checkbox"/> 分判合約 |

內容：

C 版: 附上 6TH 大圖，請按此圖拆圖，另請提供保護方案

B 版: 附上確認修改基仔做 560 高資料

A 版: 請查閱附件提供佛沙窗大圖 (5th submission)

優先計算鋁料 BM

王良: 請安排提供本項目使用的保護方案

謝謝

請在 2021. 12 前完成上列要求。

附：

以上項目為：

- 原合約工程包                       原合約工程加 / 減賬                       新工程報價

原因：-

分發東莞各部門：

- ( ) 生產技術總監  連附件 ( ) 技術部  連附件 ( ) 生產部  連附件 ( ) 機械設計部  連附件  
 ( ) 採購部  連附件 ( ) 生產統籌部  連附件 ( ) 小羅 & 清  連附件  
 ( ) 質檢部  連附件 ( ) 會計部  連附件 ( ) 報關組  連附件 ( ) 其他 \_\_\_\_\_  連附件

分發其他分判：

- ( ) 水洪  連附件

分發香港各部門：

- ( ) 行政部  連附件 ( ) 會計部  連附件 ( ) 統籌部  連附件 ( ) 工程部地盤科文  連附件  
 ( ) 採購部  連附件 ( ) QS 部  連附件 ( ) 維修部  連附件 ( ) 其他 \_\_\_\_\_  連附件

傳遞編號：

HK 2189 / 21

發件人簽署：

項目經理簽署：

PROJECT :

6

PROPOSED DEVELOPMENT ABOVE  
LIGHT RAIL TIN WING STOP, TSWTL  
NO.23, AREA 33, TIN SHUI WAI, N.T.

SHOP DRAWING FOR ALUM. PRECAST WINDOW OF TOWER

DATE: 29-Nov-21

 美特鋁質有限公司  
MIDI ALUMINIUM FABRICATOR LTD.

Units 6-8, Sunray Industrial Centre, 1/F  
610 Cha Kwo Ling Road, Kowloon  
Tel:23489211-4 Fax:(852)27727666

# DRAWING SUBMISSION REGISTER

DRAWING TITLE	DWG. NO.	DATE OF ISSUE						SUBMISSION STATE (FOR B.D./A.S.D)			SUBMISSION STATE (FOR CLIENT / CONSULTANT)			SUBMISSION STATE (FOR ARCHITECT)			FABRICATION / CONSTRUCTION STATE							
		REVISIONS						COMMENT DATE	REV.	STATE	COMMENT DATE	REV.	STATE	COMMENT DATE	REV.	STATE	REV.	DATE	REV.	DATE	REV.	DATE		
		ISSUE	1	2	3	4	5																6	DAY
COVER PAGE	J856-SD-PW-0000	-	A	B	C	D	E																	
DRAWING REGISTER	J856-SD-PW-0001	-	A	A	A	B	C																	
DRAWING REGISTER	J856-SD-PW-0002	-	A	A	A	B	C																	
DRAWING REGISTER	J856-SD-PW-0003	-	A	B	B	C	D																	
DRAWING REGISTER	J856-SD-PW-0004	-	A	B	B	B	B																	
DRAWING REGISTER	J856-SD-PW-0005	-	A	B	B	C	C																	
GENERAL NOTES FOR ALUM. WINDOW	J856-SD-PW-GN01	-	-	-	-	-	-																	
EXTRUSION LIST FOR ALUM. WINDOW	J856-SD-PW-1101	-	A	A	A	B	B																	
EXTRUSION LIST FOR ALUM. WINDOW	J856-SD-PW-1102	-	-	A	A	A	A																	
PLAN FOR ALUM. WINDOW AT TOWER 1(3/F)	J856-SD-PW-3101	-	-	-	-	-	A																	
PLAN FOR ALUM. WINDOW AT TOWER 1(5/F-42/F)	J856-SD-PW-3102	-	A	A	A	B	C																	
PLAN FOR ALUM. WINDOW AT TOWER 1(43/F)	J856-SD-PW-3103	-	-	-	-	-	-																	
PLAN FOR ALUM. WINDOW AT TOWER 1(45/F)	J856-SD-PW-3104	-	-	-	-	-	-																	
PLAN FOR ALUM. WINDOW AT TOWER 1(46/F)	J856-SD-PW-3105	-	-	-	-	-	-																	
PLAN FOR ALUM. WINDOW AT TOWER 2(3/F)	J856-SD-PW-3201	-	-	-	-	-	A																	
PLAN FOR ALUM. WINDOW AT TOWER 2(3/F-42/F)	J856-SD-PW-3202	-	A	A	A	B	C																	
PLAN FOR ALUM. WINDOW AT TOWER 2(43/F)	J856-SD-PW-3203	-	-	-	-	-	-																	
PLAN FOR ALUM. WINDOW AT TOWER 2(45/F)	J856-SD-PW-3204	-	-	-	-	-	-																	
PLAN FOR ALUM. WINDOW AT TOWER 2(46/F)	J856-SD-PW-3205	-	-	-	-	-	-																	
PLAN FOR ALUM. WINDOW AT TOWER 3(3/F)	J856-SD-PW-3301	-	-	-	-	-	A																	
PLAN FOR ALUM. WINDOW AT TOWER 3(3/F)	J856-SD-PW-3302	-	A	B	C	D	E																	
PLAN FOR ALUM. WINDOW AT TOWER 3(43/F)	J856-SD-PW-3303	-	-	-	-	-	-																	
PLAN FOR ALUM. WINDOW AT TOWER 3(45/F)	J856-SD-PW-3304	-	-	-	-	-	-																	
PLAN FOR ALUM. WINDOW AT TOWER 3(46/F)	J856-SD-PW-3305	-	-	-	-	-	-																	
WINDOW SCHEDULE FOR TOWER 1 ALUM. WINDOW	J856-SD-PW-5101	-	A	A	A	B	C																	
WINDOW SCHEDULE FOR TOWER 1 ALUM. WINDOW	J856-SD-PW-5102	-	-	-	-	A	B																	
WINDOW SCHEDULE FOR TOWER 1 ALUM. WINDOW	J856-SD-PW-5103	-	-	-	-	A	B																	
WINDOW SCHEDULE FOR TOWER 1 ALUM. WINDOW	J856-SD-PW-5104	-	A	A	A	B	C																	
WINDOW SCHEDULE FOR TOWER 1 ALUM. WINDOW	J856-SD-PW-5105	-	-	-	-	A	B																	
WINDOW SCHEDULE FOR TOWER 1 ALUM. WINDOW	J856-SD-PW-5106	-	A	A	A	B	C																	
WINDOW SCHEDULE FOR TOWER 1 ALUM. WINDOW	J856-SD-PW-5107	-	-	-	-	A	B																	
WINDOW SCHEDULE FOR TOWER 1 ALUM. WINDOW	J856-SD-PW-5108	-	-	-	-	A	B																	
WINDOW SCHEDULE FOR TOWER 1 ALUM. WINDOW	J856-SD-PW-5109	-	A	A	A	B	C																	
WINDOW SCHEDULE FOR TOWER 1 ALUM. WINDOW	J856-SD-PW-5110	-	A	A	A	B	C																	
WINDOW SCHEDULE FOR TOWER 1 ALUM. WINDOW	J856-SD-PW-5111	-	A	A	A	B	C																	
WINDOW SCHEDULE FOR TOWER 1 ALUM. WINDOW	J856-SD-PW-5112	-	A																					
WINDOW SCHEDULE FOR TOWER 1 ALUM. WINDOW	J856-SD-PW-5113	-	A																					
WINDOW SCHEDULE FOR TOWER 1 ALUM. WINDOW	J856-SD-PW-5114	-	A																					
WINDOW SCHEDULE FOR TOWER 1 ALUM. WINDOW	J856-SD-PW-5115	-	-																					
WINDOW SCHEDULE FOR TOWER 1 ALUM. WINDOW	J856-SD-PW-5116	-	-																					
WINDOW SCHEDULE FOR TOWER 1 ALUM. WINDOW	J856-SD-PW-5117	-	A																					
WINDOW SCHEDULE FOR TOWER 1 ALUM. WINDOW	J856-SD-PW-5118	-	A																					

IN-HOUSE DESIGN CHECKER

**美特鋁質有限公司**  
**MIDI ALUMINIUM FABRICATOR LTD.**  
 Units 6-8, Sunray Industrial Centre, 1/F  
 610 Cho Kwo Ling Road, Kowloon  
 Tel: 23489211-4 Fax: (852) 27272666  
 DWG NO. : J852-SD-PW-0001 REV. : C

# DRAWING SUBMISSION REGISTER

PROJECT: PROPOSED DEVELOPMENT ABOVE LIGHT RAIL TIN WING STOP, TSWTL NO.23, AREA 33, TIN SHUI WAI, N.T. TITLE: ALUM. WINDOW OF TOWER SHOPDRAWING SUBMISSION		DATE OF ISSUE						SUBMISSION STATE (FOR B.D / A.S.D)			SUBMISSION STATE (FOR CLIENT / CONSULTANT)			SUBMISSION STATE (FOR ARCHITECT)			FABRICATION / CONSTRUCTION STATE																								
DRAWING TITLE	DWG. NO.	ISSUE	1	2	3	4	5	6	COMMENT DATE	REV.	STATE	COMMENT DATE	REV.	STATE	COMMENT DATE	REV.	STATE	REV.	DATE	REV.	DATE	REV.	DATE																		
		DAY	22	12	18	30	2	29																																	
		MONTH	9	10	10	10	11	11																																	
		YEAR	21	21	21	21	21	21																																	
REVISIONS																																									
WINDOW SCHEDULE FOR TOWER 1 ALUM. WINDOW	J856-SD-PW-5119	-	A																																						
WINDOW SCHEDULE FOR TOWER 1 ALUM. WINDOW	J856-SD-PW-5120	-	A																																						
WINDOW SCHEDULE FOR TOWER 1 ALUM. WINDOW	J856-SD-PW-5121	-	A																																						
WINDOW SCHEDULE FOR TOWER 1 ALUM. WINDOW	J856-SD-PW-5122	-	A																																						
WINDOW SCHEDULE FOR TOWER 1 ALUM. WINDOW	J856-SD-PW-5123	-	-																																						
WINDOW SCHEDULE FOR TOWER 1 ALUM. WINDOW	J856-SD-PW-5124	-	-																																						
WINDOW SCHEDULE FOR TOWER 1 ALUM. WINDOW	J856-SD-PW-5125	-	A																																						
WINDOW SCHEDULE FOR TOWER 1 ALUM. WINDOW	J856-SD-PW-5126	-	A																																						
WINDOW SCHEDULE FOR TOWER 1 ALUM. WINDOW	J856-SD-PW-5127	-	-																																						
WINDOW SCHEDULE FOR TOWER 1 ALUM. WINDOW	J856-SD-PW-5128	-	-																																						
WINDOW SCHEDULE FOR TOWER 1 ALUM. WINDOW	J856-SD-PW-5129	-	-																																						
WINDOW SCHEDULE FOR TOWER 1 ALUM. WINDOW	J856-SD-PW-5130	-	-																																						
WINDOW SCHEDULE FOR TOWER 1 ALUM. WINDOW	J856-SD-PW-5131	-	-																																						
WINDOW SCHEDULE FOR TOWER 1 ALUM. WINDOW	J856-SD-PW-5132	-	-																																						
WINDOW SCHEDULE FOR TOWER 1 ALUM. WINDOW	J856-SD-PW-5133	-	-																																						
WINDOW SCHEDULE FOR TOWER 1 ALUM. WINDOW	J856-SD-PW-5134	-	-																																						
WINDOW SCHEDULE FOR TOWER 1 ALUM. WINDOW	J856-SD-PW-5135	-	-																																						
WINDOW SCHEDULE FOR TOWER 1 ALUM. WINDOW	J856-SD-PW-5136	-	-																																						
WINDOW SCHEDULE FOR TOWER 1 ALUM. WINDOW	J856-SD-PW-5137	-	-																																						
WINDOW SCHEDULE FOR TOWER 1 ALUM. WINDOW	J856-SD-PW-5138	-	-																																						
WINDOW SCHEDULE FOR TOWER 1 ALUM. WINDOW	J856-SD-PW-5139	-	-																																						
WINDOW SCHEDULE FOR TOWER 1 ALUM. WINDOW	J856-SD-PW-5140	-	-																																						
WINDOW SCHEDULE FOR TOWER 1 ALUM. WINDOW	J856-SD-PW-5141	-	-																																						
WINDOW SCHEDULE FOR TOWER 1 ALUM. WINDOW	J856-SD-PW-5142	-	-																																						
WINDOW SCHEDULE FOR TOWER 1 ALUM. WINDOW	J856-SD-PW-5143	-	-																																						
WINDOW SCHEDULE FOR TOWER 1 ALUM. WINDOW	J856-SD-PW-5144	-	-																																						
WINDOW SCHEDULE FOR TOWER 1 ALUM. WINDOW	J856-SD-PW-5145	-	-																																						
WINDOW SCHEDULE FOR TOWER 2 ALUM. WINDOW	J856-SD-PW-5201	-	A	A	A	B	C																																		
WINDOW SCHEDULE FOR TOWER 2 ALUM. WINDOW	J856-SD-PW-5202	-	-	-	-	A	B																																		
WINDOW SCHEDULE FOR TOWER 2 ALUM. WINDOW	J856-SD-PW-5203	-	-	-	-	A	B																																		
WINDOW SCHEDULE FOR TOWER 2 ALUM. WINDOW	J856-SD-PW-5204	-	A	A	A	B	C																																		
WINDOW SCHEDULE FOR TOWER 2 ALUM. WINDOW	J856-SD-PW-5205	-	-	-	-	A	B																																		
WINDOW SCHEDULE FOR TOWER 2 ALUM. WINDOW	J856-SD-PW-5206	-	A	A	A	B	C																																		
WINDOW SCHEDULE FOR TOWER 2 ALUM. WINDOW	J856-SD-PW-5207	-	-	-	-	A	B																																		
WINDOW SCHEDULE FOR TOWER 2 ALUM. WINDOW	J856-SD-PW-5208	-	-	-	-	A	B																																		
WINDOW SCHEDULE FOR TOWER 2 ALUM. WINDOW	J856-SD-PW-5209	-	A	A	A	B	C																																		
WINDOW SCHEDULE FOR TOWER 2 ALUM. WINDOW	J856-SD-PW-5210	-	A	A	A	B	C																																		
WINDOW SCHEDULE FOR TOWER 2 ALUM. WINDOW	J856-SD-PW-5211	-	A	A	A	B	C																																		
WINDOW SCHEDULE FOR TOWER 2 ALUM. WINDOW	J856-SD-PW-5211a	/	-	-	-																																				
WINDOW SCHEDULE FOR TOWER 2 ALUM. WINDOW	J856-SD-PW-5212	-	-	-	-																																				
WINDOW SCHEDULE FOR TOWER 2 ALUM. WINDOW	J856-SD-PW-5213	-	-	-	-																																				
WINDOW SCHEDULE FOR TOWER 2 ALUM. WINDOW	J856-SD-PW-5214	-	A																																						
WINDOW SCHEDULE FOR TOWER 2 ALUM. WINDOW	J856-SD-PW-5215	-	A																																						

IN-HOUSE DESIGN CHECKER



**美特铝有限公司**  
**MIDI ALUMINIUM FABRICATOR LTD.**  
 Units 6-8, Sunny Industrial Centre, 1/F  
 610 Cho Kwo Ling Road, Kowloon  
 Tel: 23489211-4 Fax: (852) 27272666  
 DWG NO. : J852-SD-PW-0002 REV. : C

# DRAWING SUBMISSION REGISTER

**PROJECT:**  
**PROPOSED DEVELOPMENT ABOVE**  
**LIGHT RAIL TIN WING STOP TSWTL**  
**NO.23,AREA 33, TIN SHUI WAI, N.T.**  
**TITLE:**  
**ALUM. WINDOW OF TOWER**  
**SHOPDRAWING SUBMISSION**

ISSUE	DATE OF ISSUE					
	1	2	3	4	5	6
	DAY	22	12	18	30	5
MONTH	9	10	10	10	11	11
YEAR	21	21	21	21	21	21

DRAWING TITLE	DWG. NO.	REVISIONS						SUBMISSION STATE (FOR B.D./A.S.D)			SUBMISSION STATE (FOR CLIENT / CONSULTANT)			SUBMISSION STATE (FOR ARCHITECT)			FABRICATION / CONSTRUCTION STATE						
		1	2	3	4	5	6	COMMENT DATE	REV.	STATE	COMMENT DATE	REV.	STATE	COMMENT DATE	REV.	STATE	REV.	DATE	REV.	DATE	REV.	DATE	
WINDOW SCHEDULE FOR TOWER 2 ALUM. WINDOW	J856-SD-PW-5216	-	A																				
WINDOW SCHEDULE FOR TOWER 2 ALUM. WINDOW	J856-SD-PW-5217	-	A																				
WINDOW SCHEDULE FOR TOWER 2 ALUM. WINDOW	J856-SD-PW-5218	-	A																				
WINDOW SCHEDULE FOR TOWER 2 ALUM. WINDOW	J856-SD-PW-5219	-	A																				
WINDOW SCHEDULE FOR TOWER 2 ALUM. WINDOW	J856-SD-PW-5220	-	-																				
WINDOW SCHEDULE FOR TOWER 2 ALUM. WINDOW	J856-SD-PW-5221	-	-																				
WINDOW SCHEDULE FOR TOWER 2 ALUM. WINDOW	J856-SD-PW-5222	-	A																				
WINDOW SCHEDULE FOR TOWER 2 ALUM. WINDOW	J856-SD-PW-5223	-	A																				
WINDOW SCHEDULE FOR TOWER 2 ALUM. WINDOW	J856-SD-PW-5224	-	-																				
WINDOW SCHEDULE FOR TOWER 2 ALUM. WINDOW	J856-SD-PW-5225	-	-																				
WINDOW SCHEDULE FOR TOWER 2 ALUM. WINDOW	J856-SD-PW-5226	-	-																				
WINDOW SCHEDULE FOR TOWER 2 ALUM. WINDOW	J856-SD-PW-5227	-	-																				
WINDOW SCHEDULE FOR TOWER 2 ALUM. WINDOW	J856-SD-PW-5228	-	-																				
WINDOW SCHEDULE FOR TOWER 2 ALUM. WINDOW	J856-SD-PW-5229	-	-																				
WINDOW SCHEDULE FOR TOWER 2 ALUM. WINDOW	J856-SD-PW-5230	-	-																				
WINDOW SCHEDULE FOR TOWER 2 ALUM. WINDOW	J856-SD-PW-5231	-	-																				
WINDOW SCHEDULE FOR TOWER 2 ALUM. WINDOW	J856-SD-PW-5232	-	-																				
WINDOW SCHEDULE FOR TOWER 2 ALUM. WINDOW	J856-SD-PW-5233	-	-																				
WINDOW SCHEDULE FOR TOWER 2 ALUM. WINDOW	J856-SD-PW-5234	-	-																				
WINDOW SCHEDULE FOR TOWER 2 ALUM. WINDOW	J856-SD-PW-5235	-	-																				
WINDOW SCHEDULE FOR TOWER 2 ALUM. WINDOW	J856-SD-PW-5236	-	-																				
WINDOW SCHEDULE FOR TOWER 2 ALUM. WINDOW	J856-SD-PW-5237	-	-																				
WINDOW SCHEDULE FOR TOWER 2 ALUM. WINDOW	J856-SD-PW-5238	-	-																				
WINDOW SCHEDULE FOR TOWER 2 ALUM. WINDOW	J856-SD-PW-5239	-	-																				
WINDOW SCHEDULE FOR TOWER 2 ALUM. WINDOW	J856-SD-PW-5240	-	-																				
WINDOW SCHEDULE FOR TOWER 2 ALUM. WINDOW	J856-SD-PW-5241	-	-																				
WINDOW SCHEDULE FOR TOWER 2 ALUM. WINDOW	J856-SD-PW-5301	-	-	A	B	C	D																
WINDOW SCHEDULE FOR TOWER 3 ALUM. WINDOW	J856-SD-PW-5302	-	-	-	-																		
WINDOW SCHEDULE FOR TOWER 3 ALUM. WINDOW	J856-SD-PW-5303	-	-	-	-																		
WINDOW SCHEDULE FOR TOWER 3 ALUM. WINDOW	J856-SD-PW-5304	-	-	A	B	C	D	E															
WINDOW SCHEDULE FOR TOWER 3 ALUM. WINDOW	J856-SD-PW-5305	-	-	A	B	C	D	E															
WINDOW SCHEDULE FOR TOWER 3 ALUM. WINDOW	J856-SD-PW-5306	-	-	A	B	C	D																
WINDOW SCHEDULE FOR TOWER 3 ALUM. WINDOW	J856-SD-PW-5307	-	-	A	B	C	D																
WINDOW SCHEDULE FOR TOWER 3 ALUM. WINDOW	J856-SD-PW-5308	-	-	A	B	C	D	E															
WINDOW SCHEDULE FOR TOWER 3 ALUM. WINDOW	J856-SD-PW-5309	-	-	A	B	C	D	E															
WINDOW SCHEDULE FOR TOWER 3 ALUM. WINDOW	J856-SD-PW-5310	-	-	A	B	B	B	C															
WINDOW SCHEDULE FOR TOWER 3 ALUM. WINDOW	J856-SD-PW-5311	-	-	A	B	B	B	B															
WINDOW SCHEDULE FOR TOWER 3 ALUM. WINDOW	J856-SD-PW-5312	-	-	A																			
WINDOW SCHEDULE FOR TOWER 3 ALUM. WINDOW	J856-SD-PW-5312a	-	-	A	B																		
WINDOW SCHEDULE FOR TOWER 3 ALUM. WINDOW	J856-SD-PW-5313	-	-	A	B																		
WINDOW SCHEDULE FOR TOWER 3 ALUM. WINDOW	J856-SD-PW-5314	-	-	A	B																		
WINDOW SCHEDULE FOR TOWER 3 ALUM. WINDOW	J856-SD-PW-5315	-	-	A																			

IN-HOUSE DESIGN CHECKER

# DRAWING SUBMISSION REGISTER

PROJECT: PROPOSED DEVELOPMENT ABOVE LIGHT RAIL TIN WING STOP TSWTL NO.23, AREA 33, TIN SHUI WAI, N. T. TITLE: ALUM. WINDOW OF TOWER SHOPDRAWING SUBMISSION		DATE OF ISSUE						SUBMISSION STATE (FOR B.D / A.S.D)			SUBMISSION STATE (FOR CLIENT / CONSULTANT)			SUBMISSION STATE (FOR ARCHITECT)			FABRICATION / CONSTRUCTION STATE					
		ISSUE	1	2	3	4	5	6	AP - APPROVED	AC - APPROVED SUB. TO CONDITION	NA - NOT APPROVED	AP - APPROVED	AC - APPROVED SUB. TO CONDITION	NA - NOT APPROVED	AP - APPROVED	AC - APPROVED SUB. TO CONDITION	NA - NOT APPROVED	ISSUE TO CHINA OFFICE	ISSUE TO SITE	ISSUE TO SUB-CONTRACTOR		
DRAWING TITLE		DWG. NO.		REVISIONS						COMMENT DATE	REV.	STATE	COMMENT DATE	REV.	STATE	COMMENT DATE	REV.	STATE	REV.	DATE	REV.	DATE
		DAY	MONTH	YEAR	21	21	21	21	21	21	21	21	21	21	21	21	21	21	21	21	21	21
WINDOW SCHEDULE FOR TOWER 3 ALUM. WINDOW	J856-SD-PW-5316	-	-	A																		
WINDOW SCHEDULE FOR TOWER 3 ALUM. WINDOW	J856-SD-PW-5317	-	A	B																		
WINDOW SCHEDULE FOR TOWER 3 ALUM. WINDOW	J856-SD-PW-5318	-	-	A																		
WINDOW SCHEDULE FOR TOWER 3 ALUM. WINDOW	J856-SD-PW-5319	-	-	A																		
WINDOW SCHEDULE FOR TOWER 3 ALUM. WINDOW	J856-SD-PW-5320	-	A	B																		
WINDOW SCHEDULE FOR TOWER 3 ALUM. WINDOW	J856-SD-PW-5321	-	A	B																		
WINDOW SCHEDULE FOR TOWER 3 ALUM. WINDOW	J856-SD-PW-5322	-	-	A																		
WINDOW SCHEDULE FOR TOWER 3 ALUM. WINDOW	J856-SD-PW-5323	-	-	A																		
WINDOW SCHEDULE FOR TOWER 3 ALUM. WINDOW	J856-SD-PW-5324	-	A	B																		
WINDOW SCHEDULE FOR TOWER 3 ALUM. WINDOW	J856-SD-PW-5325	-	-	A																		
WINDOW SCHEDULE FOR TOWER 3 ALUM. WINDOW	J856-SD-PW-5326	-	-	A																		
WINDOW SCHEDULE FOR TOWER 3 ALUM. WINDOW	J856-SD-PW-5327	-	A	B																		
WINDOW SCHEDULE FOR TOWER 3 ALUM. WINDOW	J856-SD-PW-5328	-	A	B																		
WINDOW SCHEDULE FOR TOWER 3 ALUM. WINDOW	J856-SD-PW-5329	-	-	A																		
WINDOW SCHEDULE FOR TOWER 3 ALUM. WINDOW	J856-SD-PW-5330	-	A	B																		
WINDOW SCHEDULE FOR TOWER 3 ALUM. WINDOW	J856-SD-PW-5331	-	A	B																		
WINDOW SCHEDULE FOR TOWER 3 ALUM. WINDOW	J856-SD-PW-5332	-	A	B																		
WINDOW SCHEDULE FOR TOWER 3 ALUM. WINDOW	J856-SD-PW-5333	-	A	B																		
WINDOW SCHEDULE FOR TOWER 3 ALUM. WINDOW	J856-SD-PW-5334	-	A	B																		
WINDOW SCHEDULE FOR TOWER 3 ALUM. WINDOW	J856-SD-PW-5335	-	A	B																		
WINDOW SCHEDULE FOR TOWER 3 ALUM. WINDOW	J856-SD-PW-5336	-	-	A																		
WINDOW SCHEDULE FOR TOWER 3 ALUM. WINDOW	J856-SD-PW-5337	-	-	A																		
WINDOW SCHEDULE FOR TOWER 3 ALUM. WINDOW	J856-SD-PW-5338	-	-	A																		
WINDOW SCHEDULE FOR TOWER 3 ALUM. WINDOW	J856-SD-PW-5339	-	-	A																		
WINDOW SCHEDULE FOR TOWER 3 ALUM. WINDOW	J856-SD-PW-5340	-	-	A																		
WINDOW SCHEDULE FOR TOWER 3 ALUM. WINDOW	J856-SD-PW-5341	-	-																			
WINDOW SCHEDULE FOR TOWER 3 ALUM. WINDOW	J856-SD-PW-5342	-	-																			
WINDOW SCHEDULE FOR TOWER 3 ALUM. WINDOW	J856-SD-PW-5343	-	-																			
WINDOW SCHEDULE FOR TOWER 3 ALUM. WINDOW	J856-SD-PW-5344	-	-																			
WINDOW SCHEDULE FOR TOWER 3 ALUM. WINDOW	J856-SD-PW-5345	-	-																			
WINDOW SCHEDULE FOR TOWER 3 ALUM. WINDOW	J856-SD-PW-5346	-	-																			
WINDOW SCHEDULE FOR TOWER 3 ALUM. WINDOW	J856-SD-PW-5347	-	-																			
WINDOW SCHEDULE FOR TOWER 3 ALUM. WINDOW	J856-SD-PW-5348	-	-																			
WINDOW SCHEDULE FOR TOWER 3 ALUM. WINDOW	J856-SD-PW-5349	-	-																			
WINDOW SCHEDULE FOR TOWER 3 ALUM. WINDOW	J856-SD-PW-5350	-	-																			
WINDOW SCHEDULE FOR TOWER 3 ALUM. WINDOW	J856-SD-PW-5351	-	-																			
WINDOW SCHEDULE FOR TOWER 3 ALUM. WINDOW	J856-SD-PW-5352	-	-																			
WINDOW SCHEDULE FOR TOWER 3 ALUM. WINDOW	J856-SD-PW-5353	-	-																			
WINDOW SCHEDULE FOR TOWER 3 ALUM. WINDOW	J856-SD-PW-5354	-	-																			
WINDOW SCHEDULE FOR TOWER 3 ALUM. WINDOW	J856-SD-PW-5355	-	-																			
WINDOW SCHEDULE FOR TOWER 3 ALUM. WINDOW	J856-SD-PW-5356	-	-																			
WINDOW SCHEDULE FOR TOWER 3 ALUM. WINDOW	J856-SD-PW-5357	-	-																			

IN-HOUSE DESIGN CHECKER

**美特铝有限公司**  
MIDI ALUMINIUM FABRICATOR LTD.

Units 6-8, Sunny Industrial Centre, 1/F  
610 Cho Kwo Ling Road, Kowloon  
Tel: 23489211-4 Fax: (852) 2727666

DWG NO. : J856-SD-PW-0004 REV. : B

# DRAWING SUBMISSION REGISTER

PROJECT: PROPOSED DEVELOPMENT ABOVE LIGHT RAIL TIN WING STOP, TSWTL NO.23, AREA 33, TIN SHUI WAI, N.T.	DATE OF ISSUE						SUBMISSION STATE (FOR B.D / A.S.D)			SUBMISSION STATE (FOR CLIENT / CONSULTANT)			SUBMISSION STATE (FOR ARCHITECT)			FABRICATION / CONSTRUCTION STATE													
	TITLE: ALUM. WINDOW OF TOWER SHOPDRAWING SUBMISSION						ISSUE	1	2	3	4	5	6	AP - APPROVED	AC - APPROVED SUB. TO CONDITION	NA - NOT APPROVED	AP - APPROVED	AC - APPROVED SUB. TO CONDITION	NA - NOT APPROVED	ISSUE TO CHINA OFFICE	ISSUE TO SITE	ISSUE TO SUB-CONTRACTOR							
	DAY	22	12	18	30	5	29	MONTH	9	10	10	10	11	11	YEAR	21	21	21	21	21	21	21	21						
DRAWING TITLE	DWG. NO.	REVISIONS												COMMENT DATE	REV.	STATE	COMMENT DATE	REV.	STATE	COMMENT DATE	REV.	STATE	REV.	DATE	REV.	DATE	REV.	DATE	
		1	2	3	4	5	6	7	8	9	10	11	12																
WINDOW SCHEDULE FOR TOWER 3 ALUM. WINDOW	J856-SD-PW-5386	-	-	-	-	-	-	-	-	-	-	-	-	-	-	-	-	-	-	-	-	-	-	-	-	-	-	-	-
WINDOW SCHEDULE FOR TOWER 3 ALUM. WINDOW	J856-SD-PW-5389	-	-	-	-	-	-	-	-	-	-	-	-	-	-	-	-	-	-	-	-	-	-	-	-	-	-	-	-
WINDOW SCHEDULE FOR TOWER 3 ALUM. WINDOW	J856-SD-PW-5390	-	-	-	-	-	-	-	-	-	-	-	-	-	-	-	-	-	-	-	-	-	-	-	-	-	-	-	-
WINDOW SCHEDULE FOR TOWER 3 ALUM. WINDOW	J856-SD-PW-5361	-	-	-	-	-	-	-	-	-	-	-	-	-	-	-	-	-	-	-	-	-	-	-	-	-	-	-	-
TYPICAL DETAILS FOR ALUM. WINDOW	J856-SD-PW-DT61	-	-	-	-	-	-	-	-	-	-	-	-	-	-	-	-	-	-	-	-	-	-	-	-	-	-	-	-
TYPICAL DETAILS FOR ALUM. WINDOW	J856-SD-PW-DT61a	-	-	-	-	-	-	-	-	-	-	-	-	-	-	-	-	-	-	-	-	-	-	-	-	-	-	-	-
TYPICAL DETAILS FOR ALUM. WINDOW	J856-SD-PW-DT62	-	-	-	-	-	-	-	-	-	-	-	-	-	-	-	-	-	-	-	-	-	-	-	-	-	-	-	-
TYPICAL DETAILS FOR ALUM. WINDOW	J856-SD-PW-DT63	-	-	-	-	-	-	-	-	-	-	-	-	-	-	-	-	-	-	-	-	-	-	-	-	-	-	-	-
TYPICAL DETAILS FOR ALUM. WINDOW	J856-SD-PW-DT64	-	-	-	-	-	-	-	-	-	-	-	-	-	-	-	-	-	-	-	-	-	-	-	-	-	-	-	-
TYPICAL DETAILS FOR ALUM. WINDOW	J856-SD-PW-DT71	-	-	-	-	-	-	-	-	-	-	-	-	-	-	-	-	-	-	-	-	-	-	-	-	-	-	-	-
TYPICAL DETAILS FOR ALUM. WINDOW	J856-SD-PW-DT71a	-	-	-	-	-	-	-	-	-	-	-	-	-	-	-	-	-	-	-	-	-	-	-	-	-	-	-	-
TYPICAL DETAILS FOR ALUM. WINDOW	J856-SD-PW-DT72	-	-	-	-	-	-	-	-	-	-	-	-	-	-	-	-	-	-	-	-	-	-	-	-	-	-	-	-
TYPICAL DETAILS FOR ALUM. WINDOW	J856-SD-PW-DT73	-	-	-	-	-	-	-	-	-	-	-	-	-	-	-	-	-	-	-	-	-	-	-	-	-	-	-	-
TYPICAL DETAILS FOR ALUM. WINDOW	J856-SD-PW-DT73a	-	-	-	-	-	-	-	-	-	-	-	-	-	-	-	-	-	-	-	-	-	-	-	-	-	-	-	-
ALUM. WINDOW SECTION TYPICAL LOCK & HINGES DETAIL	J856-SD-PW-DT74	-	-	-	-	-	-	-	-	-	-	-	-	-	-	-	-	-	-	-	-	-	-	-	-	-	-	-	-
G.M.S FIXING LUG TYPICAL DETAIL FOR ALUM. WINDOW	J856-SD-PW-DT74A	-	-	-	-	-	-	-	-	-	-	-	-	-	-	-	-	-	-	-	-	-	-	-	-	-	-	-	-
G.M.S FIXING LUG TYPICAL DETAIL FOR ALUM. WINDOW	J856-SD-PW-DT75	-	-	-	-	-	-	-	-	-	-	-	-	-	-	-	-	-	-	-	-	-	-	-	-	-	-	-	-
TYPICAL EARTHING BONDING DETAILS OF PRECAST	J856-SD-PW-DT76	-	-	-	-	-	-	-	-	-	-	-	-	-	-	-	-	-	-	-	-	-	-	-	-	-	-	-	-
TYPICAL EARTHING BONDING DETAILS OF PRECAST	J856-SD-PW-DT77	-	-	-	-	-	-	-	-	-	-	-	-	-	-	-	-	-	-	-	-	-	-	-	-	-	-	-	-
TYPICAL EARTHING BONDING DETAILS OF PRECAST	J856-SD-PW-DT78	-	-	-	-	-	-	-	-	-	-	-	-	-	-	-	-	-	-	-	-	-	-	-	-	-	-	-	-

IN-HOUSE DESIGN CHECKER

**美特鋁質有限公司**  
MIDI ALUMINUM FABRICATOR LTD.

Units 6-8, Sunny Industrial Centre, 1/F  
610 Cho Kwo Ling Road, Kowloon  
Tel: 23489211-4 Fax: (852) 2727666

DWG NO. : J856-SD-PW-0005      REV. : C



PROPERTIES

MEMBER : IW-17  
GRADE : 6063-T6  
FINISH : PVF2  
3-COATING

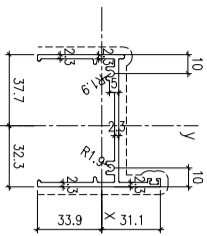

MASS PROPERTIES (MM)  
MASS (kg/m<sup>3</sup>): 2780  
Perimeter (mm): 413.7  
...  
Principal moments of inertia I<sub>x</sub> (mm<sup>4</sup>): 209843.0  
I<sub>y</sub> (mm<sup>4</sup>): 209843.0  
I<sub>xy</sub> (mm<sup>4</sup>): 0.0

PROPERTIES

MEMBER : AW-21  
GRADE : 6063-T6  
FINISH : PVF2 3-COATING

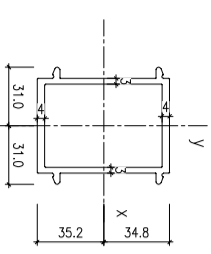

MASS PROPERTIES (MM)  
MASS (kg/m<sup>3</sup>): 2780  
Perimeter (mm): 413.7  
...  
Principal moments of inertia I<sub>x</sub> (mm<sup>4</sup>): 209843.0  
I<sub>y</sub> (mm<sup>4</sup>): 209843.0  
I<sub>xy</sub> (mm<sup>4</sup>): 0.0

PROPERTIES

MEMBER : AW-25  
GRADE : 6063-T6  
FINISH : PVF2 3-COATING

REGIONS

PROPERTIES

MEMBER : AW-29  
GRADE : 6063-T6  
FINISH : PVF2 3-COATING

REGIONS

PROPERTIES

MEMBER : AW-18  
GRADE : 6063-T6  
FINISH : PVF2 3-COATING

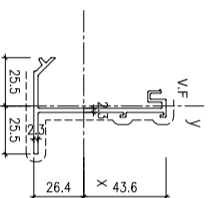

MASS PROPERTIES (MM)  
MASS (kg/m<sup>3</sup>): 2780  
Perimeter (mm): 354.4  
...  
Principal moments of inertia I<sub>x</sub> (mm<sup>4</sup>): 156473.2  
I<sub>y</sub> (mm<sup>4</sup>): 156473.2  
I<sub>xy</sub> (mm<sup>4</sup>): 0.0

PROPERTIES

MEMBER : AW-22  
GRADE : 6063-T6  
FINISH : PVF2 3-COATING

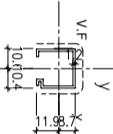

MASS PROPERTIES (MM)  
MASS (kg/m<sup>3</sup>): 2780  
Perimeter (mm): 324.0  
...  
Principal moments of inertia I<sub>x</sub> (mm<sup>4</sup>): 118800.0  
I<sub>y</sub> (mm<sup>4</sup>): 118800.0  
I<sub>xy</sub> (mm<sup>4</sup>): 0.0

PROPERTIES

MEMBER : AW-28  
GRADE : 6063-T6  
FINISH : PVF2 3-COATING

REGIONS

PROPERTIES

MEMBER : AW-30  
GRADE : 6063-T6  
FINISH : PVF2 3-COATING

REGIONS

PROPERTIES

MEMBER : AW-19  
GRADE : 6061-T6  
FINISH : MILL

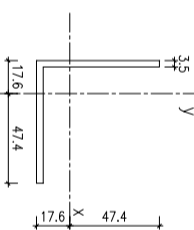

MASS PROPERTIES (MM)  
MASS (kg/m<sup>3</sup>): 2780  
Perimeter (mm): 262.0  
...  
Principal moments of inertia I<sub>x</sub> (mm<sup>4</sup>): 209843.0  
I<sub>y</sub> (mm<sup>4</sup>): 209843.0  
I<sub>xy</sub> (mm<sup>4</sup>): 0.0

PROPERTIES

MEMBER : AW-23  
GRADE : 6063-T6  
FINISH : PVF2 3-COATING

REGIONS

PROPERTIES

MEMBER : AW-27  
GRADE : 6063-T6  
FINISH : PVF2 3-COATING

REGIONS

PROPERTIES

MEMBER : AW-31  
GRADE : 6063-T6  
FINISH : PVF2 3-COATING

REGIONS

PROPERTIES

MEMBER : AW-20  
GRADE : 6061-T6  
FINISH : MILL

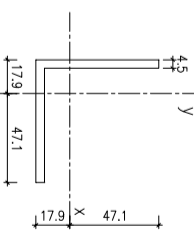

MASS PROPERTIES (MM)  
MASS (kg/m<sup>3</sup>): 2780  
Perimeter (mm): 262.0  
...  
Principal moments of inertia I<sub>x</sub> (mm<sup>4</sup>): 209843.0  
I<sub>y</sub> (mm<sup>4</sup>): 209843.0  
I<sub>xy</sub> (mm<sup>4</sup>): 0.0

PROPERTIES

MEMBER : AW-24  
GRADE : 6063-T6  
FINISH : PVF2 3-COATING

REGIONS

PROPERTIES

MEMBER : AW-28  
GRADE : 6063-T6  
FINISH : PVF2 3-COATING

REGIONS

PROPERTIES

MEMBER : AW-32  
GRADE : 6063-T6  
FINISH :

REGIONS

B.O. REF :

CLIENT :  
SUN HUNG KAI  
REAL ESTATE AGENCY LTD.  
42/F SUN HUNG KAI CENTRE, WANCHAI, HONGKONG

ARCHITECT :  
IWK&partners  
a r c h i t e c t s

MAIN CONTRACTOR :  
怡輝建築有限公司  
Yee Fai Building Contractors Ltd.

STRUCTURAL ENGINEER :  
ARUP

FAÇADE CONSULTANT :  
ALPHA CONSULTING LIMITED  
Steel Structure & Façade Specialist

NOTE :  
1. ALL DIMENSIONS ARE IN mm.  
2. ALL ELEVATIONS ARE VIEWED FROM OUTSIDE.  
3. ALL DIMENSIONS TO BE VERIFIED ON SITE BEFORE FABRICATION.

LEGEND :  
X1 - DETAIL MARK NO.  
X001 - REFER SHEET NO.  
1. F.F.L. -- FINISHED FLOOR LEVEL  
2. S.F.L. -- STRUCTURAL FLOOR LEVEL  
3. (R) -- REVERSED DETAIL  
4. GLASS LEGEND  
EGL-1 -- 6mmHS+12mm AIR GAP+10mmTP THK. I.G.U.  
EGL-2 -- 10mm THK. CLEAR TEMPERED GLASS  
EGL-4 -- 10mm THK. TEMPERED ACID ETCHED GLASS  
EGL-1A -- 8mmHS+12mm AIR GAP+8mmTP THK. I.G.U.

REVISION SUBJECT TO ARCH/COMMENT  
NO. DATE REVISION  
A 02/11/2020

JOB NO. : J-856  
PROJECT : PROPOSED DEVELOPMENT ABOVE LIGHT RAIL TIN WING STOP TSWTL NO.23,AREA 33,TIN SHUI WAI, N.T.  
TITLE : DIE LIST FOR ALUM. WINDOW  
DATE : 02-Aug-21 SCALE : 1:40  
DRAWN BY : Ivorn CHECKED BY :

MIDI ALUMINIUM FABRICATOR LTD.  
Units 6-8, Sunny Industrial Centre, 1/F  
610 Cho Kwo Ling Road, Kowloon  
Tel:23489211-4 Fax:8522727666  
DWG NO. : JB56-SD-PW-1102 REV. : A



# TOWER 1 3/F

B.O. REF : . . . . .

CLIENT :



SUN HUNG KAI  
REAL ESTATE AGENCY LTD.

42/F SUN HUNG KAI CENTRE, WINGHAI, HONGKONG

ARCHITECT :



IWK&partners  
ARCHITECTS

MAIN CONTRACTOR :



怡輝建築有限公司  
Yee Fai Building Contractors Ltd.

STRUCTURAL ENGINEER :



ARUP

FAÇADE CONSULTANT:



ALPHA CONSULTING LIMITED  
Steel Structure & Façade Specialist

NOTE :

1. ALL DIMENSIONS ARE IN mm.
2. ALL ELEVATIONS ARE VIEWED FROM OUTSIDE.
3. ALL DIMENSIONS TO BE VERIFIED ON SITE BEFORE FABRICATION.

LEGEND :

- ⊗11 --- DETAIL MARK NO.
- ⊗001 --- REFER SHEET NO.

1. F.F.L. --- FINISHED FLOOR LEVEL
2. S.F.L. --- STRUCTURAL FLOOR LEVEL
3. Ⓟ --- REVERSED DETAIL
4. GLASS LEGEND

EQ.1-1---8mmHS+12mm AIR GAP+8mmTP THK. 1G.U.  
EQ.2---10mm THK. CLEAR TEMPERED GLASS  
EQ.4---10mm THK. TEMPERED ACID ETCHED GLASS

NO.	DATE	REVISION SUBJECT TO ADOPTMENT	BY
A.	29/10/2021	REVISION SUBJECT TO ADOPTMENT	WON

JOB NO. : J-856

PROJECT :  
PROPOSED DEVELOPMENT ABOVE  
LIGHT RAIL TIN WING STOP-TSWTL  
NO.23.AREA 33.TIN SHUI WAI, N.T.

TITLE :  
PLAN FOR ALUM. WINDOW  
AT TOWER 1

DATE : 02-Aug-21 SCALE : 1:40

DRAWN BY : Iwon CHECKED BY :

美特鋁質有限公司  
MIDI ALUMINIUM FABRICATOR LTD.  
Units 6-8, Sunray Industrial Centre, 1/F  
610 Ona Kwo Ling Road, Kowloon  
Tel:23489211-4 Fax:(852)2727866  
DWG NO. : J856-SD-PW-3101 REV. : A

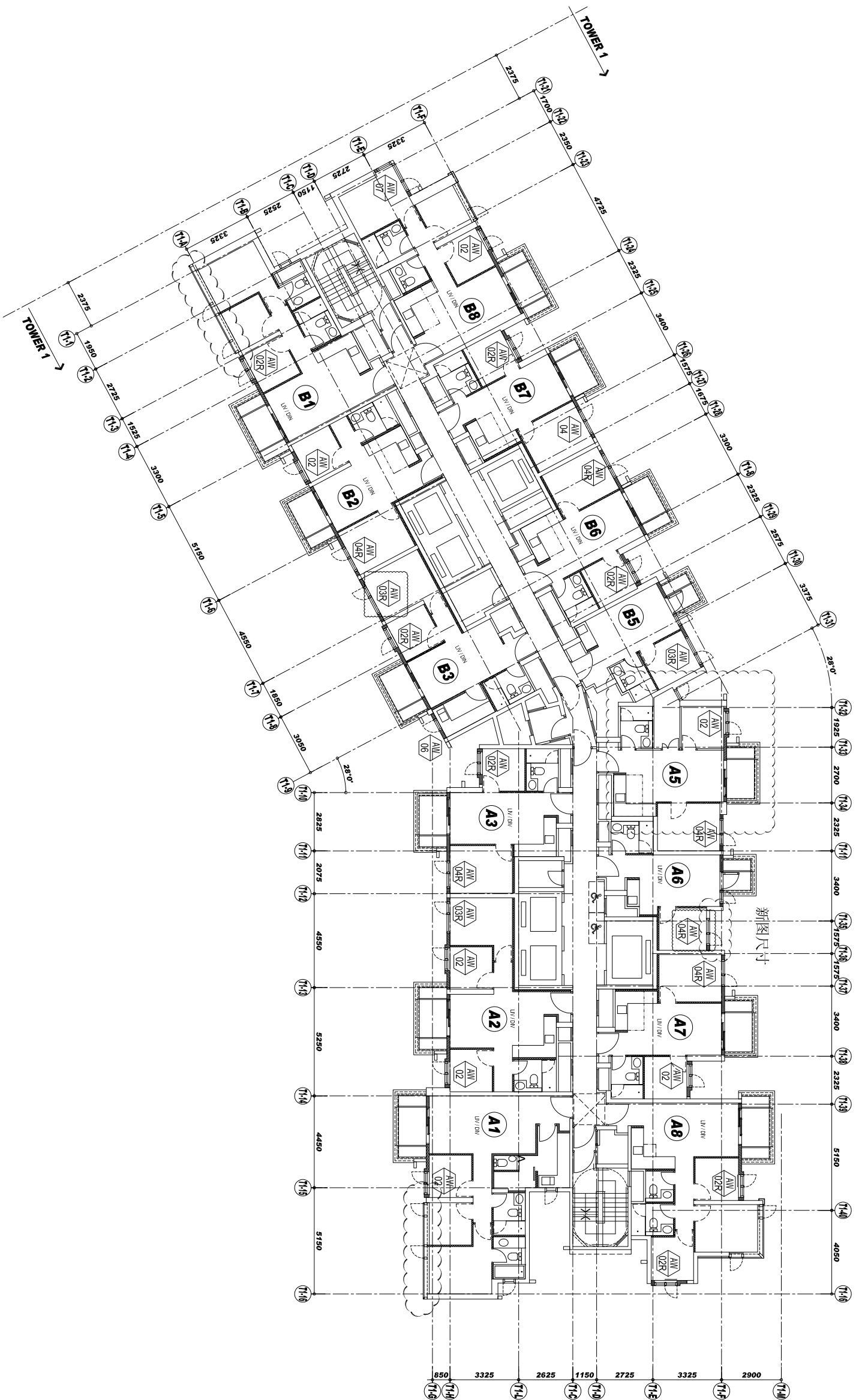

# TOWER 1 5/F-42/F

B.O. REF :

CLIENT :

**SUN HUNG KAI**  
REAL ESTATE AGENCY LTD.  
42/F SUN HUNG KAI CENTRE, WANGCHAI, HONGKONG

ARCHITECT :

**Iwk&partners**  
A R C H I T E C T S

MAIN CONTRACTOR :

**怡輝建築有限公司**  
**Yee Fai** Building Contractors Ltd.

STRUCTURAL ENGINEER :

**ARUP**

FAÇADE CONSULTANT :

**ALPHA CONSULTING LIMITED**  
Steel Structure & Façade Specialist

NOTE :

1. ALL DIMENSIONS ARE IN mm.
2. ALL ELEVATIONS ARE VIEWED FROM OUTSIDE.
3. ALL DIMENSIONS TO BE VERIFIED ON SITE BEFORE FABRICATION.

LEGEND :

- ⊗11 — DETAIL MARK NO.
- ⊗001 — REFER SHEET NO.

1. F.F.L. -- FINISHED FLOOR LEVEL
2. S.F.L. -- STRUCTURAL FLOOR LEVEL
3. Ⓡ -- REVERSED DETAIL
4. GLASS LEGEND

EGL-1--8mmHS+12mm AIR GAP+6mmTP THK. I.G.U.  
EGL-2--10mm THK. CLEAR TEMPERED GLASS  
EGL-4--10mm THK. TEMPERED ACID ETCHED GLASS

NO.	DATE	REVISION	REVISION SUBJECT TO ARCHITECTMENT
C	29/11/2021		REVISION SUBJECT TO ARCHITECTMENT
B	03/11/2021		REVISION SUBJECT TO ARCHITECTMENT
A	18/10/2021		REVISION SUBJECT TO ARCHITECTMENT

JOB NO. : J-856

PROJECT :

PROPOSED DEVELOPMENT ABOVE  
LIGHT RAIL TIN WING STOP-TSWTL  
NO.23,AREA 33,TIN SHUI WAI, N.T.

TITLE :

PLAN FOR IN-SITU WINDOW  
AT TOWER 1

DATE : 02-Aug-21 SCALE : 1:40

DRAWN BY : Iwon CHECKED BY :

**美特鋁質有限公司**  
**MIDI ALUMINIUM FABRICATOR LTD.**  
Units 6-8, Sunray Industrial Centre, 1/F  
610 Cha Kwo Ling Road, Kowloon  
Tel:23489211-4 Fax:(852)27277866

DWG NO. : J856-SD-IW-3102 REV. : C

B.O. REF :

CLIENT :

**SUN HUNG KAI**  
REAL ESTATE AGENCY LTD.

42/F SUN HUNG KAI CENTRE, WANGCHAI, HONGKONG

ARCHITECT :

**lwk&partners**  
A R C H I T E C T S

MAIN CONTRACTOR :

**怡輝建築有限公司**  
Yee Fai Building Contractors Ltd.

STRUCTURAL ENGINEER :

**ARUP**

FAÇADE CONSULTANT:

**ALPHA CONSULTING LIMITED**  
Steel Structure & Façade Specialist

NOTE:

1. ALL DIMENSIONS ARE IN mm.
2. ALL ELEVATIONS ARE VIEWED FROM OUTSIDE.
3. ALL DIMENSIONS TO BE VERIFIED ON SITE BEFORE FABRICATION.

LEGEND:

- ⊗11—DETAIL MARK NO.
- ⊗001—REFER SHEET NO.

1. F.F.L.--FINISHED FLOOR LEVEL
2. S.F.L.--STRUCTURAL FLOOR LEVEL
3. Ⓡ--REVERSED DETAIL

4. GLASS LEGEND

EGL-1--8mmHS+12mm AIR GAP+6mmTP THK. L.G.U.  
 EGL-2--10mm THK. CLEAR TEMPERED GLASS  
 EGL-4--10mm THK. TEMPERED ACID ETCHED GLASS

NO.	DATE	REVISION SUBJECT TO ARCH/COMPONENT	BY
A	29/10/2021	REVISION SUBJECT TO ARCH/COMPONENT	NON

JOB NO. : J-856

PROJECT : PROPOSED DEVELOPMENT ABOVE LIGHT RAIL TIN WING STOP TSWTL NO.23,AREA 33,TIN SHUI WAI, N.T.

TITLE : PLAN FOR ALUM. WINDOW AT TOWER 2

DATE : 02-Aug-21 SCALE : 1:40

DRAWN BY : Iwon CHECKED BY :

**美特鋁質有限公司**  
MIDI ALUMINIUM FABRICATOR LTD.  
Units 6-8, Sunray Industrial Centre, 1/F  
610 Cho Kwong Road, Kowloon  
Tel:23489211-4 Fax:(852)27277666

DWG NO. : J856-SD-PW-3201 REV. : A

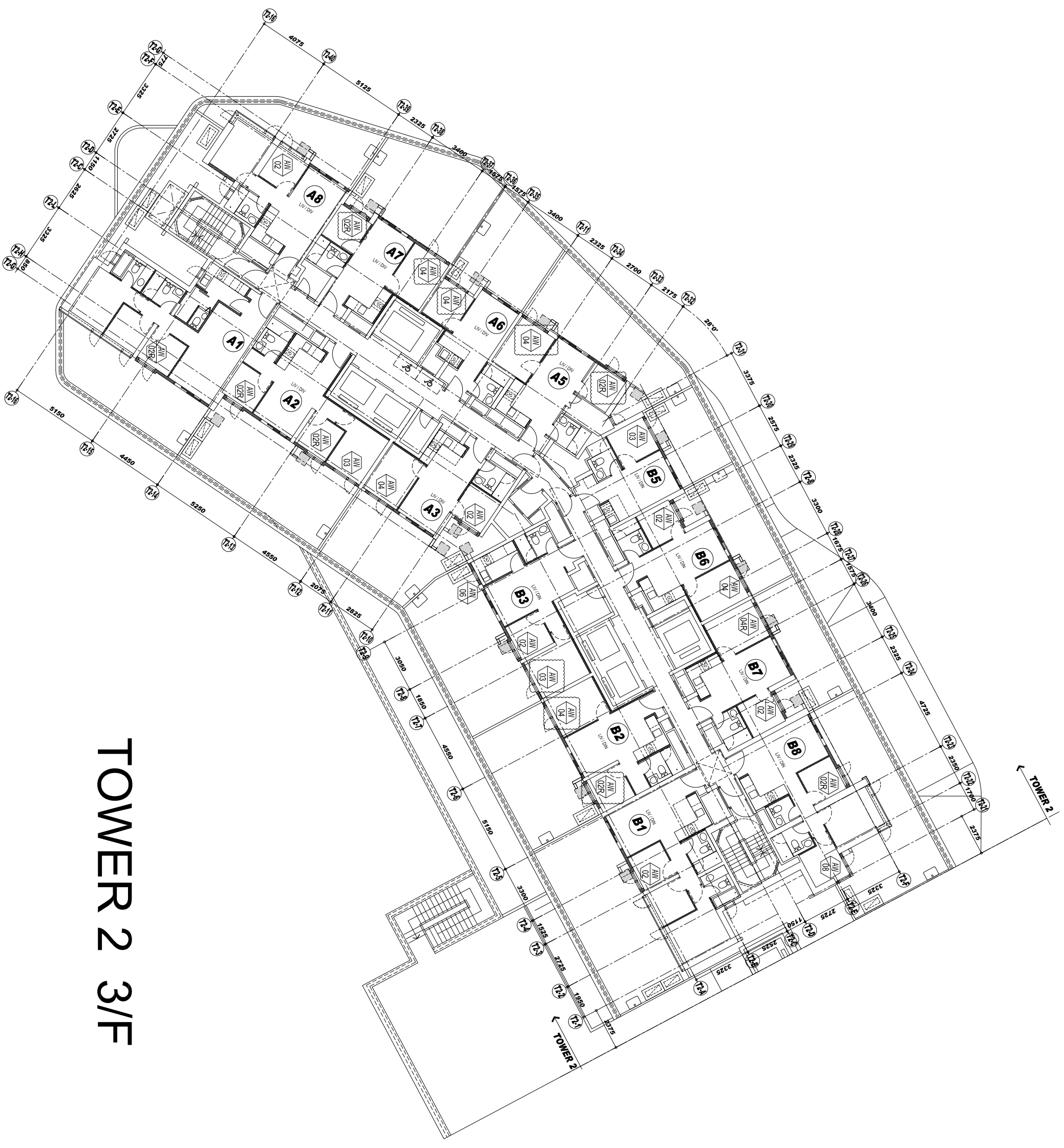

# TOWER 2 3/F

B.O. REF :

CLIENT :

**SUN HUNG KAI**  
REAL ESTATE AGENCY LTD.

42/F, SUN HUNG KAI CENTRE, WANGCHAI, HONGKONG

ARCHITECT :

**lwk&partners**  
A R C H I T E C T S

MAIN CONTRACTOR :

**怡輝建築有限公司**  
**Yee Fai** Building Contractors Ltd.

STRUCTURAL ENGINEER :

**ARUP**

FAÇADE CONSULTANT:

**ALPHA CONSULTING LIMITED**  
Steel Structure & Façade Specialist

NOTE :

1. ALL DIMENSIONS ARE IN mm.
2. ALL ELEVATIONS ARE VIEWED FROM OUTSIDE.
3. ALL DIMENSIONS TO BE VERIFIED ON SITE BEFORE FABRICATION.

LEGEND :

⊗11—DETAIL MARK NO.  
⊗001—REFER SHEET NO.

1. F.F.L.--FINISHED FLOOR LEVEL
2. S.F.L.--STRUCTURAL FLOOR LEVEL
3. Ⓡ--REVERSED DETAIL
4. GLASS LEGEND

EGL-1--8mmHS+12mm AIR GAP+8mmTP THK. I.G.U.  
EGL-2--10mm THK. CLEAR TEMPERED GLASS  
EGL-4--10mm THK. TEMPERED ACID ETCHED GLASS

NO.	DATE	REVISION	REVISION SUBJECT TO ARCH/COMPONENT
C	26/11/2021	REVISION SUBJECT TO ARCH/COMPONENT	None
B	03/11/2021	REVISION SUBJECT TO ARCH/COMPONENT	None
A	18/10/2021	REVISION SUBJECT TO ARCH/COMPONENT	None

JOB NO. : J-856

PROJECT :

PROPOSED DEVELOPMENT ABOVE  
LIGHT RAIL TIN WING STOP-TSWTL  
NO.23,AREA 33,TIN SHUI WAI, N.T.

TITLE :

PLAN FOR IN-SITU WINDOW  
AT TOWER 2

DATE : 02-Aug-21 SCALE : 1:40

DRAWN BY : Ivon CHECKED BY :

**美特鋁質有限公司**  
MIDI ALUMINIUM FABRICATOR LTD.  
Units 6-8, Sunray Industrial Centre, 1/F  
610 Cho Kwong Road, Kowloon  
Tel:23489211-4 Fax:(852)27277866

DWG NO. : J856-SD-IW-3202

REV. : C



# TOWER 2 5/F-42/F

CLIENT :

**SUN HUNG KAI**  
**REAL ESTATE AGENCY LTD.**  
 42/F SUN HUNG KAI CENTRE, WINGHUA, HONGKONG

ARCHITECT :  
**lwk&partners**  
 a r c h i t e c t s

MAIN CONTRACTOR :  
**怡輝建築有限公司**  
**Yee Fai Building Contractors Ltd.**

STRUCTURAL ENGINEER :  
**ARUP**

FAÇADE CONSULTANT:  
**ALPHA CONSULTING LIMITED**  
 Steel Structure & Façade Specialist

NOTE:  
 1. ALL DIMENSIONS ARE IN mm.  
 2. ALL ELEVATIONS ARE VIEWED FROM OUTSIDE.  
 3. ALL DIMENSIONS TO BE VERIFIED ON SITE BEFORE FABRICATION.

LEGEND:

⊗11—DETAIL MARK NO.  
 ⊗001—REFER SHEET NO.

1. F.F.L.—FINISHED FLOOR LEVEL  
 2. S.F.L.—STRUCTURAL FLOOR LEVEL  
 3. Ⓡ—REVERSED DETAIL  
 4. GLASS LEGEND

EQ-1—8mmHS+12mm AIR GAP+8mmTP THK. L.G.U.  
 EQ-2—10mm THK. CLEAR TEMPERED GLASS  
 EQ-4—10mm THK. TEMPERED ACID ETCHED GLASS

NO.	DATE	REVISION SUBJECT TO ADOPTMENT	BY
A	29/11/2021	REVISION SUBJECT TO ADOPTMENT	NON

JOB NO. : J-856

PROJECT :  
 PROPOSED DEVELOPMENT ABOVE  
 LIGHT RAIL TIN WING STOP-TSWTL  
 NO.23,AREA 33,TIN SHUI WAI, N.T.

TITLE :  
 PLAN FOR ALUM. WINDOW  
 AT TOWER 3

DATE : 02-Aug-21 SCALE : 1:40

DRAWN BY : Ivon CHECKED BY :

**美特鋁質有限公司**  
**MIDI ALUMINIUM FABRICATOR LTD.**  
 Units 6-8, Sunray Industrial Centre, 1/F  
 610 Chee Kwong Road, Kowloon  
 Tel:23489211-4 Fax:(852)2727866  
 DWG NO. : J856-SD-PW-3301 REV. : A

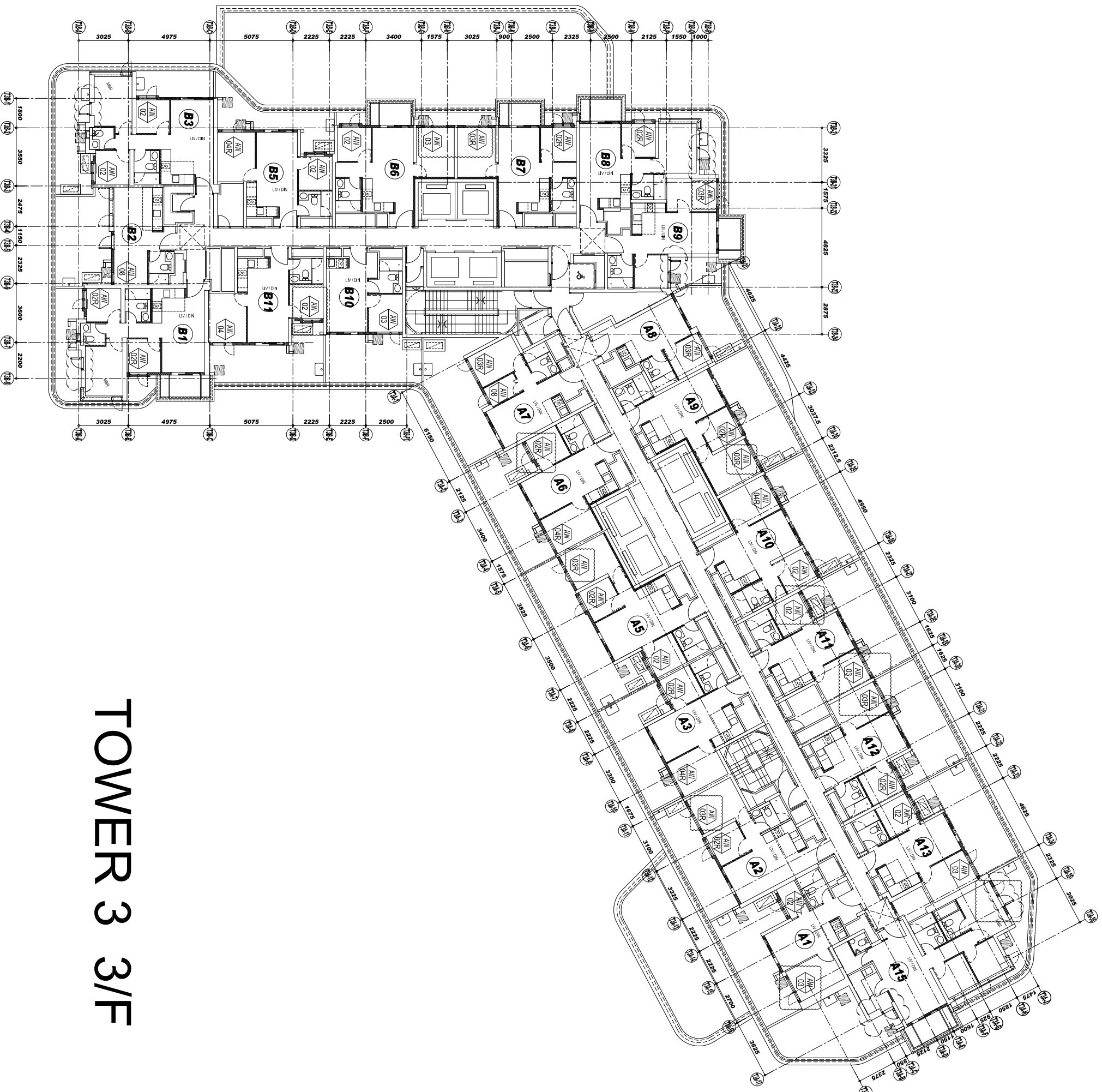

# TOWER 3 3/F

B.O. REF :

CLIENT :

**SUN HUNG KAI**  
REAL ESTATE AGENCY LTD.

42/F SUN HUNG KAI CENTRE, WINGHUA, HONGKONG

ARCHITECT :

**IWK&partners**  
A R C H I T E C T S

MAIN CONTRACTOR :

**怡輝建築有限公司**  
**Yee Fai** Building Contractors Ltd.

STRUCTURAL ENGINEER :

**ARUP**

FAÇADE CONSULTANT:

**ALPHA CONSULTING LIMITED**  
Steel Structure & Façade Specialist

NOTE :

1. ALL DIMENSIONS ARE IN mm.
2. ALL ELEVATIONS ARE VIEWED FROM OUTSIDE.
3. ALL DIMENSIONS TO BE VERIFIED ON SITE BEFORE FABRICATION.

LEGEND :

**X1** — DETAIL MARK NO.  
**X001** — REFER SHEET NO.

1. F.F.L. — FINISHED FLOOR LEVEL
2. S.F.L. — STRUCTURAL FLOOR LEVEL
3. **R** — REVERSED DETAIL
4. GLASS LEGEND

EQ1-1—8mmHS+12mm AIR GAP+8mmTP THK. LG.U.  
EQ1-2—10mm THK. CLEAR TEMPERED GLASS  
EQ1-4—10mm THK. TEMPERED ACID ETCHED GLASS

NO.	DATE	REVISION
E	29/11/2021	REVISION SUBJECT TO ARCH/COMMITMENT
D	02/11/2021	REVISION SUBJECT TO ARCH/COMMITMENT
C	28/10/2021	REVISION SUBJECT TO ARCH/COMMITMENT
B	18/10/2021	REVISION SUBJECT TO ARCH/COMMITMENT
A	30/09/2021	REVISION SUBJECT TO ARCH/COMMITMENT

JOB NO. : J-856

PROJECT :

PROPOSED DEVELOPMENT ABOVE  
LIGHT RAIL TIN WING STOP-TSWTL  
NO.23,AREA 33,TIN SHUI WAI, N.T.

TITLE :

PLAN FOR IN-SITU WINDOW  
AT TOWER 3

DATE : 02-Aug-21 SCALE : 1:40

DRAWN BY : Iwon CHECKED BY :

**美特鋁質有限公司**  
**MIDI ALUMINIUM FABRICATOR LTD.**  
Units 6-8, Sunray Industrial Centre, 1/F  
610 Cho Kwong Road, Kowloon  
Tel:23489211-4 Fax:(852)27277866

DWG NO. : J856-SD-IW-3302 REV. : E

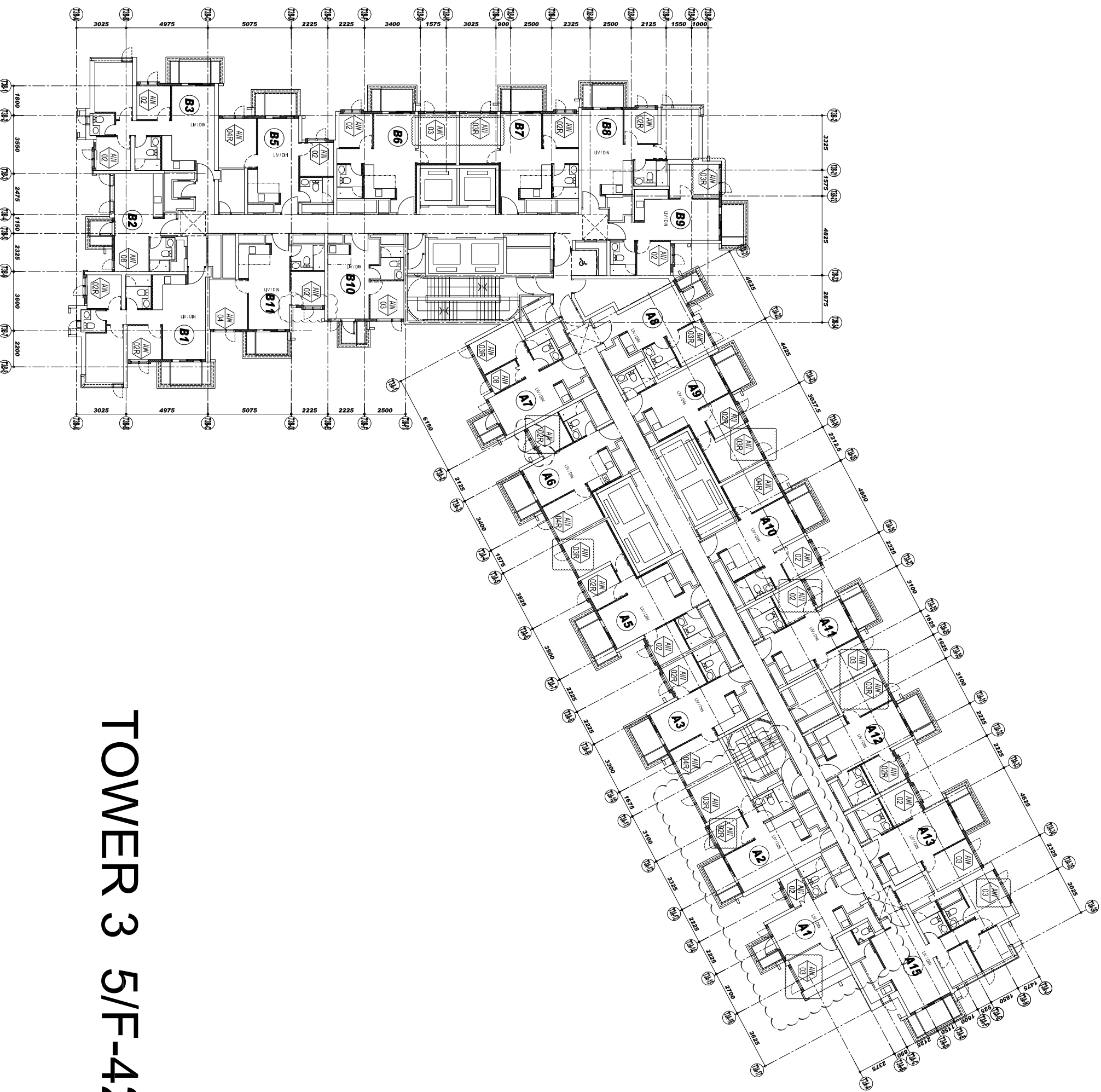

# TOWER 3 5/F-42/F

B.O. REF :

CLIENT :

**SUN HUNG KAI**  
REAL ESTATE AGENCY LTD.  
42/F SUN HUNG KAI CENTRE, WINGHUA, HONGKONG

ARCHITECT :

**IWK&partners**  
A R C H I T E C T S

MAIN CONTRACTOR :

**怡輝建築有限公司**  
Yee Fai Building Contractors Ltd.

STRUCTURAL ENGINEER :

**ARUP**

FAÇADE CONSULTANT:

**ALPHA CONSULTING LIMITED**  
Steel Structure & Façade Specialist

NOTE:

1. ALL DIMENSIONS ARE IN mm.
2. ALL ELEVATIONS ARE VIEWED FROM OUTSIDE.
3. ALL DIMENSIONS TO BE VERIFIED ON SITE BEFORE FABRICATION.

LEGEND:

⊗1 — DETAIL MARK NO.  
X001 — REFER SHEET NO.

1. F.F.L. -- FINISHED FLOOR LEVEL
2. S.F.L. -- STRUCTURAL FLOOR LEVEL
3. Ⓡ -- REVERSED DETAIL
4. GLASS LEGEND

EGL-1--8mmHS+12mm AIR GAP+10mmTP THK. I.G.U.  
EGL-2--10mm THK. CLEAR TEMPERED GLASS  
EGL-4--10mm THK. TEMPERED ACID ETCHED GLASS  
EGL-1A--8mmHS+12mm AIR GAP+8mmTP THK. I.G.U.

NO.	DATE	REVISION	REVISION SUBJECT TO ARCHITECTMENT
C	29/11/2021	REVISION SUBJECT TO ARCHITECTMENT	None
B	03/11/2021	REVISION SUBJECT TO ARCHITECTMENT	None
A	12/10/2021	REVISION SUBJECT TO ARCHITECTMENT	None

JOB NO. : J-856

PROJECT :

PROPOSED DEVELOPMENT ABOVE  
LIGHT RAIL TIN WING STOP TSWTL  
NO.23,AREA 33,TIN SHUI WAI, N.T.

TITLE :

WINDOW SCHEDULE FOR  
TOWER 1 ALUM. WINDOW

DATE : 02-Aug-21 SCALE : 1:40

DRAWN BY : Iwon CHECKED BY :

**美特經貿有限公司**  
MIDI Aluminium Fabricator Ltd.  
Units 6-8, Sunray Industrial Centre, 1/F  
610 Ona Kwo Ling Road, Kowloon  
Tel:23489211-4 Fax:(852)2727666

DWG NO. : J856-SD-PW-5101 REV. : C

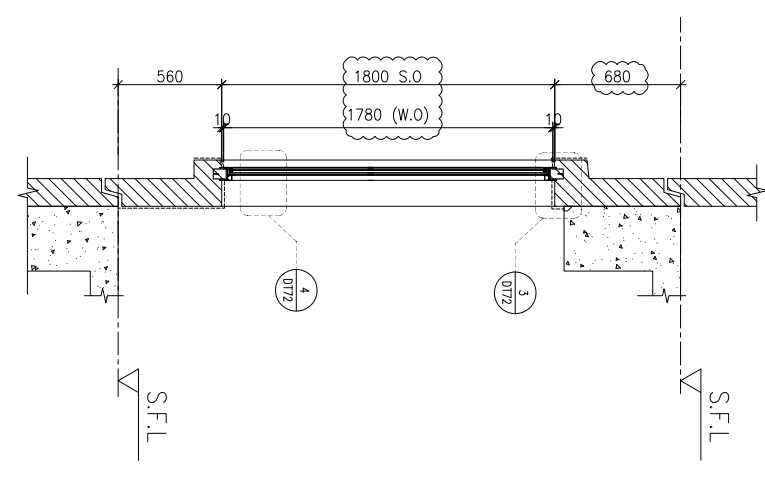
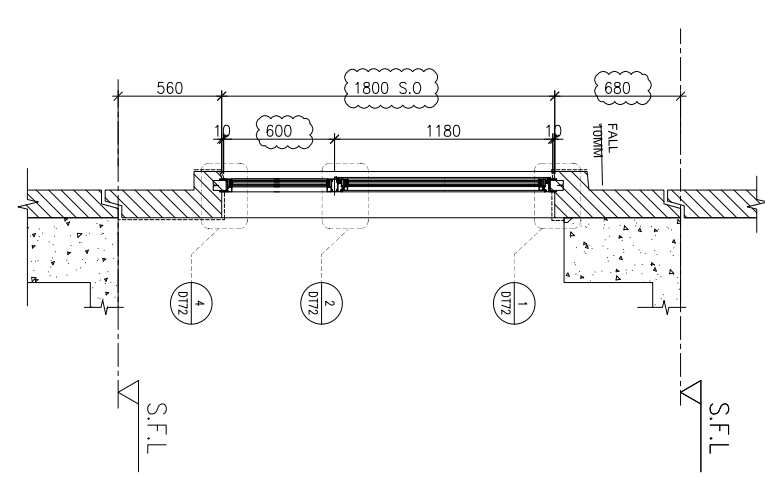
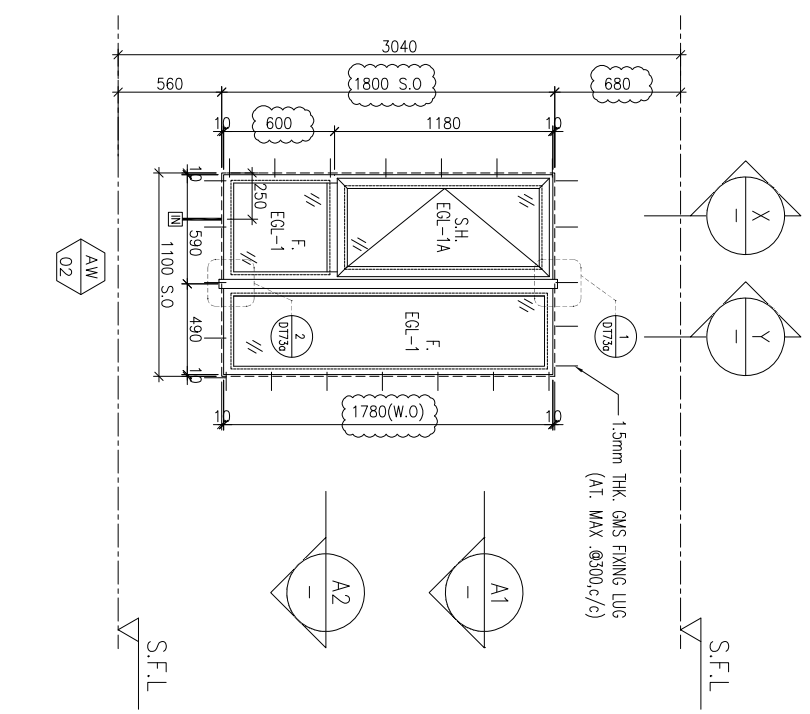

ELEVATION

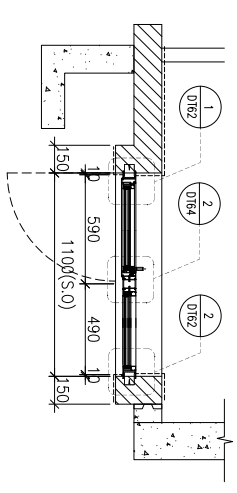

A1 PART PLAN

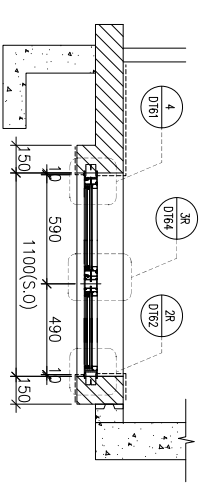

A2 PART PLAN

WINDOW MARK	AW 02
LOCATION	3/F-42/F(4/F,13/F,14/F,24/F,34/F OMITTED) UNIT A1
SECTION	70mm ALUM. SECTION
GLAZING	EGL-1,EGL-1A
QUANTITY	35 Nos.
REMARKS	FAÇADE(TYPE T1PF01 FOR 3/F~42/F)

B.O. REF :

CLIENT :

**SUN HUNG KAI**  
**REAL ESTATE AGENCY LTD.**  
 42/F SUN HUNG KAI CENTRE, WINGLOH, HONGKONG

ARCHITECT :  
**lwk&partners**  
 a r c h i t e c t s

MAIN CONTRACTOR :  
**怡輝建築有限公司**  
**Yee Fai Building Contractors Ltd.**

STRUCTURAL ENGINEER :  
**ARUP**

FAÇADE CONSULTANT:  
**ALPHA CONSULTING LIMITED**  
 Steel Structure & Façade Specialist

NOTE:  
 1. ALL DIMENSIONS ARE IN mm.  
 2. ALL ELEVATIONS ARE VIEWED FROM OUTSIDE.  
 3. ALL DIMENSIONS TO BE VERIFIED ON SITE BEFORE FABRICATION.

LEGEND:

- DETAIL MARK NO.
- REFER SHEET NO.
- 1. F.F.L.--FINISHED FLOOR LEVEL
- 2. S.F.L.--STRUCTURAL FLOOR LEVEL
- 3. --REVERSED DETAIL
- 4. GLASS LEGEND

EGL-1--8mmHS+12mm AIR GAP+10mmTP THK. I.G.U.  
 EGL-2--10mm THK. CLEAR TEMPERED GLASS  
 EGL-4--10mm THK. TEMPERED ACID ETCHED GLASS  
 EGL-1A--8mmHS+12mm AIR GAP+8mmTP THK. I.G.U.

NO.	DATE	REVISION	SUBJECT TO ARCH/COMMENT
B	29/11/2021	REVISION SUBJECT TO ARCH/COMMENT	None
A	03/11/2021	REVISION SUBJECT TO ARCH/COMMENT	None

JOB NO. : J-856

PROJECT :  
 PROPOSED DEVELOPMENT ABOVE  
 LIGHT RAIL TIN WING STOP TSWTL  
 NO.23,AREA 33,TIN SHUI WAI, N.T.

TITLE :  
 WINDOW SCHEDULE FOR  
 TOWER 1 ALUM. WINDOW

DATE : 02-Aug-21 SCALE : 1:40

DRAWN BY : Ivon CHECKED BY :

**美特鋁業有限公司**  
**MIDI Aluminium Fabricator Ltd.**  
 Units 6-8, Sunray Industrial Centre, 1/F  
 610 Ona Kwo Ling Road, Kowloon  
 Tel:23489211-4 Fax:(852)2727866  
 DWG NO. : J856-SD-PW-5102 REV. : B

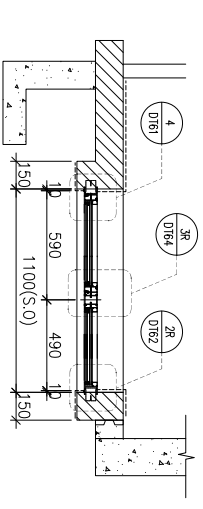
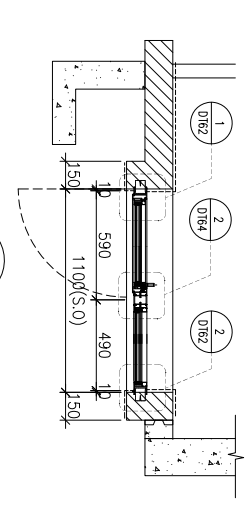
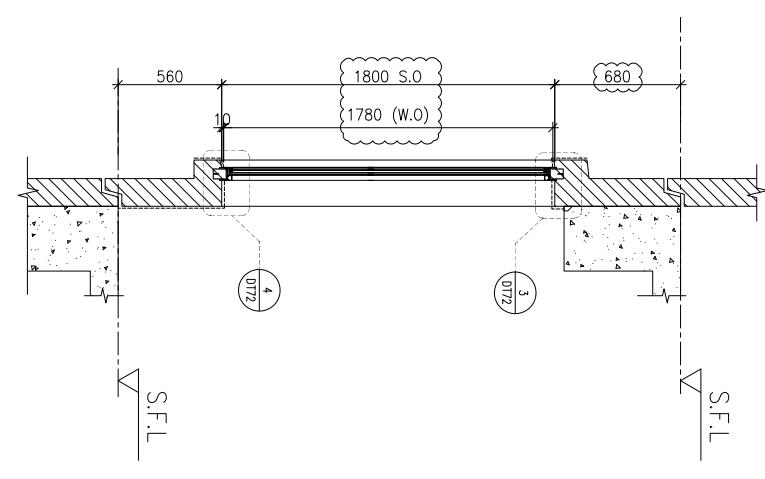
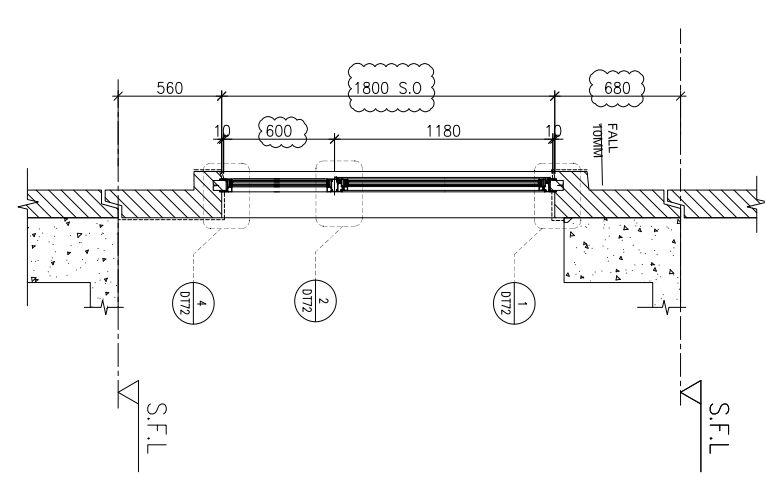
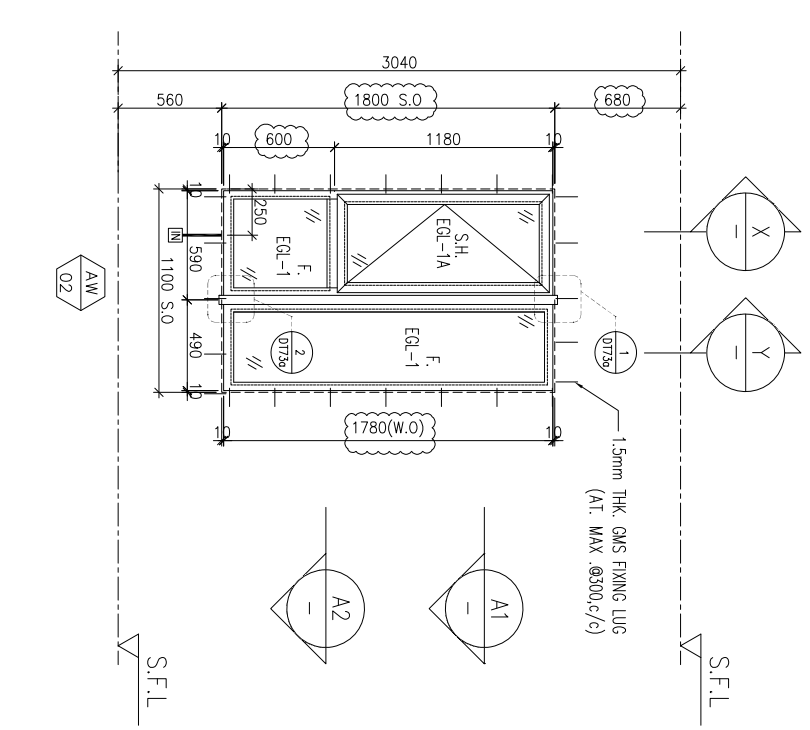

A2 PART PLAN

WINDOW MARK	LOCATION	SECTION	QUANTITY	REMARKS
	3/F-42/F(4/F,13/F,14/F,24/F,34/F OMITTED)	70mm ALUM. SECTION	35 Nos./35 Nos.	FAÇADE(TYPE T1PF02 FOR 3/F~42/F)
	3/F-42/F(4/F,13/F,14/F,24/F,34/F OMITTED)	70mm ALUM. SECTION	35 Nos.	FAÇADE(TYPE T1PF02R FOR 3/F~42/F)

B.O. REF :

CLIENT :

**SUN HUNG KAI**  
REAL ESTATE AGENCY LTD.  
42/F SUN HUNG KAI CENTRE, WINGLOH, HONGKONG

ARCHITECT :  
**IWK&partners**  
A R C H I T E C T S

MAIN CONTRACTOR :  
**怡輝建築有限公司**  
Yee Fai Building Contractors Ltd.

STRUCTURAL ENGINEER :  
**ARUP**

FAÇADE CONSULTANT:  
**ALPHA CONSULTING LIMITED**  
Steel Structure & Façade Specialist

NOTE:  
1. ALL DIMENSIONS ARE IN mm.  
2. ALL ELEVATIONS ARE VIEWED FROM OUTSIDE.  
3. ALL DIMENSIONS TO BE VERIFIED ON SITE BEFORE FABRICATION.

LEGEND:

- (X1) DETAIL MARK NO.
- (X001) REFER SHEET NO.
- 1. F.F.L. -- FINISHED FLOOR LEVEL
- 2. S.F.L. -- STRUCTURAL FLOOR LEVEL
- 3. (R) -- REVERSED DETAIL
- 4. GLASS LEGEND

EGL-1--8mmHS+12mm AIR GAP+10mmTP THK. I.G.U.  
EGL-2--10mm THK. CLEAR TEMPERED GLASS  
EGL-4--10mm THK. TEMPERED ACID ETCHED GLASS  
EGL-1A--8mmHS+12mm AIR GAP+8mmTP THK. I.G.U.

NO.	DATE	REVISION	SUBJECT TO ARCHITECTMENT
B	29/11/2021	REVISION SUBJECT TO ARCHITECTMENT	None
A	03/11/2021	REVISION SUBJECT TO ARCHITECTMENT	None

JOB NO. : J-8556

PROJECT : PROPOSED DEVELOPMENT ABOVE LIGHT RAIL TIN WING STOP TSWTL NO.23,AREA 33,TIN SHUI WAI, N.T.

TITLE : WINDOW SCHEDULE FOR TOWER 1 ALUM. WINDOW

DATE : 02-Aug-21 SCALE : 1:40

DRAWN BY : Iwon CHECKED BY :

**美特經貿有限公司**  
MIDI Aluminium Fabricator Ltd.  
Units 6-8, Sunray Industrial Centre, 1/F  
610 Ona Kwo Ling Road, Kowloon  
Tel:23489211-4 Fax:(852)2727666  
DWG NO. : J856-SD-PW-5103 REV. : B

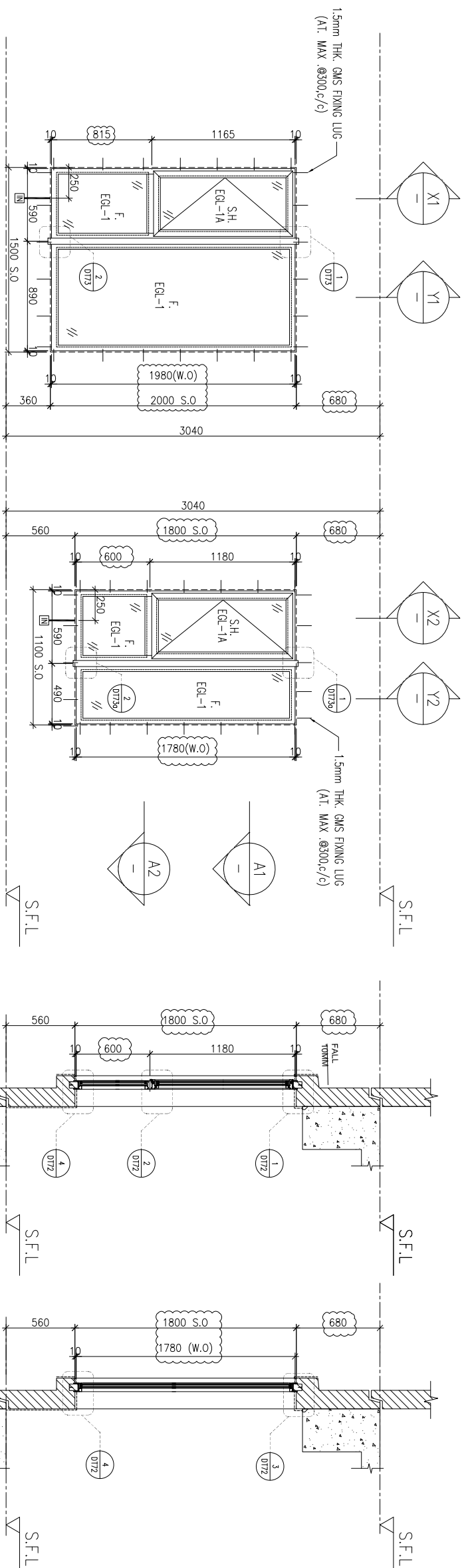

ELEVATION

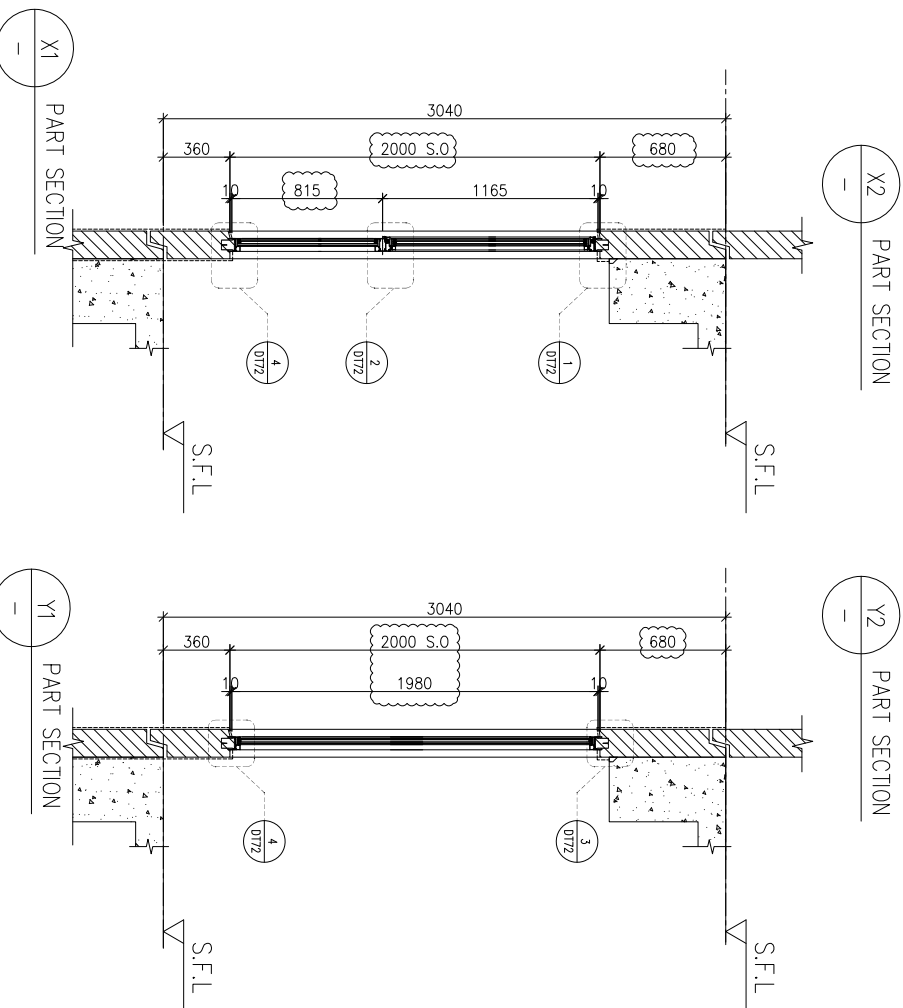
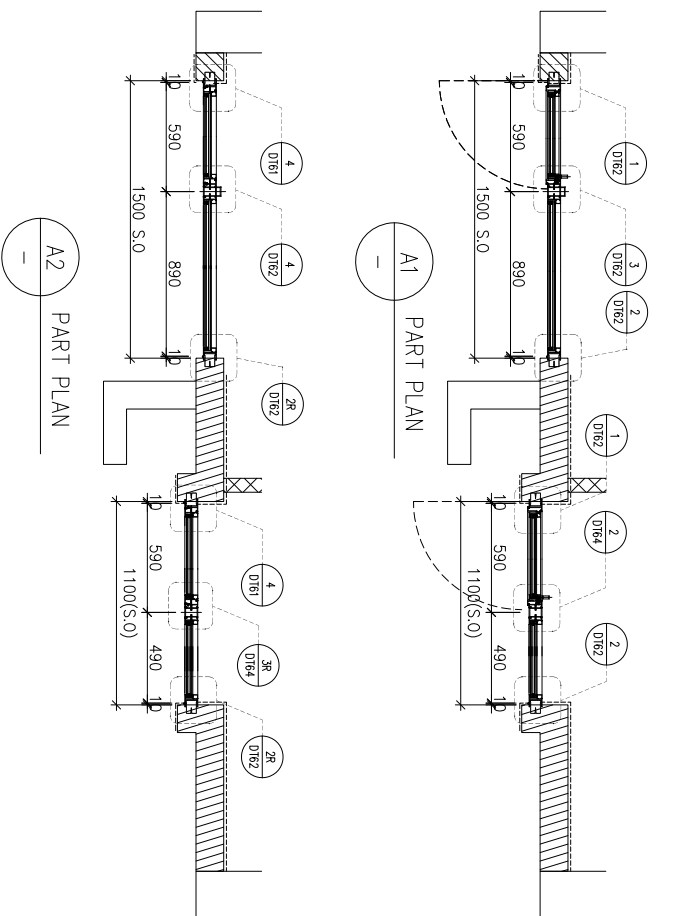

WINDOW MARK	AW 03R	AW 02
LOCATION	3/F-42/F(4/F,13/F,14/F,24/F,34/F OMITTED) UNIT A2	
SECTION	70mm ALUM. SECTION	
GLAZING	EGL-1,EGL-1A	
QUANTITY	35 Nos./35 Nos.	
REMARKS	FAÇADE TYPE T1PF03 FOR 3/F~42/F)	

B.O. REF :

CLIENT :

**SUN HUNG KAI**  
**REAL ESTATE AGENCY LTD.**  
 42/F SUN HUNG KAI CENTRE, WINGHUA, HONGKONG

ARCHITECT :

**lwk&partners**  
 a r c h i t e c t s

MAIN CONTRACTOR :

**怡輝建築有限公司**  
**Yee Fai Building Contractors Ltd.**

STRUCTURAL ENGINEER :

**ARUP**  
 ALPHA CONSULTING LIMITED  
 Steel Structure & Facade Specialist

FAÇADE CONSULTANT:

**ARUP**  
 ALPHA CONSULTING LIMITED  
 Steel Structure & Facade Specialist

NOTE :

1. ALL DIMENSIONS ARE IN mm.
2. ALL ELEVATIONS ARE VIEWED FROM OUTSIDE.
3. ALL DIMENSIONS TO BE VERIFIED ON SITE BEFORE FABRICATION.

LEGEND :

- DETAIL MARK NO.
- REFER SHEET NO.
- 1. F.F.L.--FINISHED FLOOR LEVEL
- 2. S.F.L.--STRUCTURAL FLOOR LEVEL
- 3. --REVERSED DETAIL
- 4. GLASS LEGEND

EGL-1--8mmHS+12mm AIR GAP+10mmTP THK. I.G.U.  
 EGL-2--10mm THK. CLEAR TEMPERED GLASS  
 EGL-4--10mm THK. TEMPERED ACID ETCHED GLASS  
 EGL-1A--8mmHS+12mm AIR GAP+8mmTP THK. I.G.U.

NO.	DATE	REVISION	SUBJECT TO ARCHITECTMENT
C	29/11/2021	REVISION SUBJECT TO ARCHITECTMENT	None
B	03/11/2021	REVISION SUBJECT TO ARCHITECTMENT	None
A	12/10/2021	REVISION SUBJECT TO ARCHITECTMENT	None

JOB NO. : J-856

PROJECT :

PROPOSED DEVELOPMENT ABOVE  
 LIGHT RAIL TIN WING STOP TSWTL  
 NO.23,AREA 33,TIN SHUI WAI, N.T.

TITLE :

WINDOW SCHEDULE FOR  
 TOWER 1 ALUM. WINDOW

DATE : 02-Aug-21 SCALE : 1:40

DRAWN BY : Ivon CHECKED BY :

**美特經貿有限公司**  
**MIDI Aluminium Fabricator Ltd.**  
 Units 6-8, Sunray Industrial Centre, 1/F  
 610 Ona Kwo Ling Road, Kowloon  
 Tel:23489211-4 Fax:(852)2727866  
 DWG NO. : J856-SD-PW-5104 REV. : C

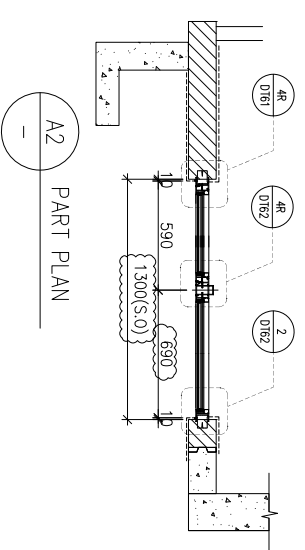
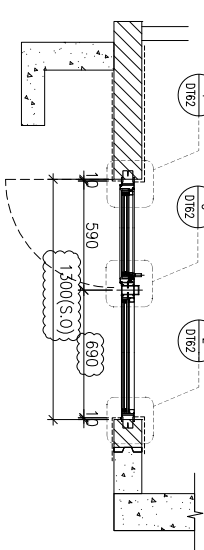
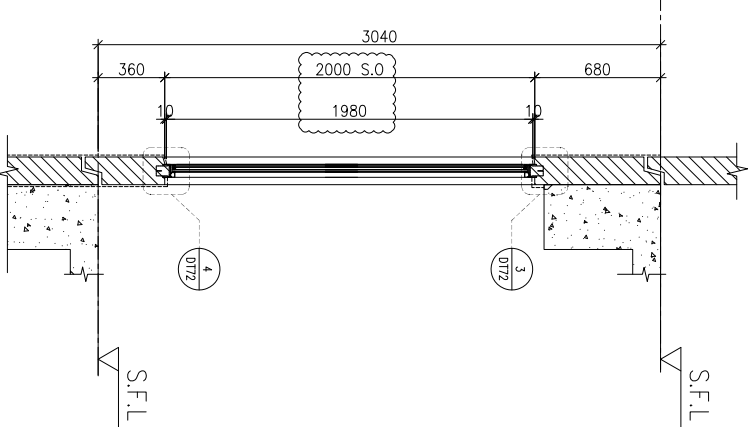
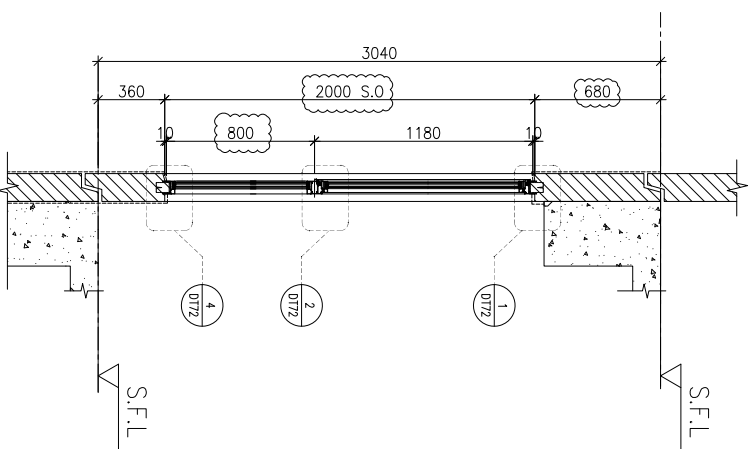
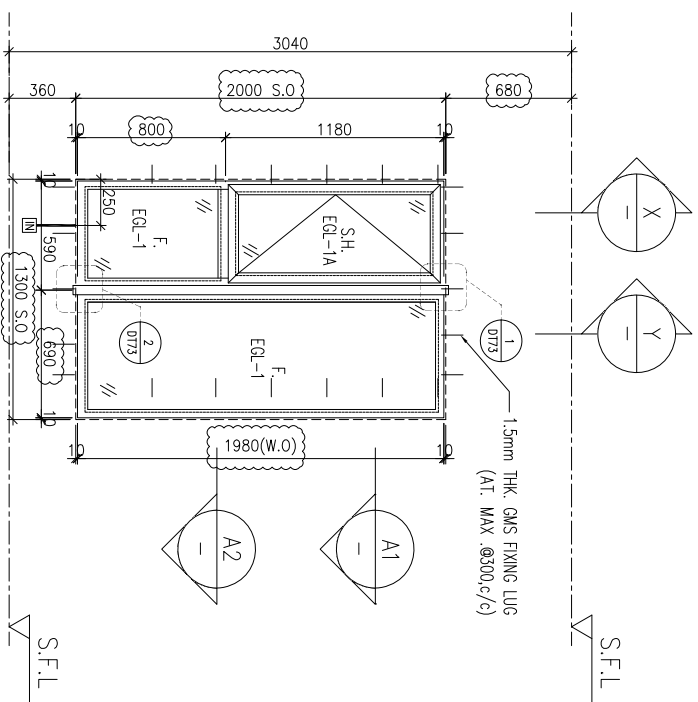

ELEVATION

WINDOW MARK	3/F-42/F(4/F,13/F,14/F,24/F,34/F OMITTED) UNIT B2,B6,A3,A7
AW 04R	70mm ALUM. SECTION
LOCATION	70mm ALUM. SECTION
SECTION	EGL-1,EGL-1A
GLAZING	35 Nos / 35 Nos / 35 Nos / 35 Nos
QUANTITY	FAÇADE(TYPE T1PF04R FOR 3/F~42/F)
REMARKS	

WINDOW MARK	3/F-42/F(4/F,13/F,14/F,24/F,34/F OMITTED) UNIT B7
AW 04	70mm ALUM. SECTION
LOCATION	70mm ALUM. SECTION
SECTION	EGL-1,EGL-1A
GLAZING	35 Nos / 35 Nos / 35 Nos / 35 Nos
QUANTITY	FAÇADE(TYPE T1PF04 FOR 3/F~42/F)
REMARKS	

B.O. REF :

CLIENT :

**SUN HUNG KAI**  
REAL ESTATE AGENCY LTD.  
42/F SUN HUNG KAI CENTRE, WINGLOH, HONGKONG

ARCHITECT :

**IWK&partners**  
A R C H I T E C T S

MAIN CONTRACTOR :

**怡輝建築有限公司**  
Yee Fai Building Contractors Ltd.

STRUCTURAL ENGINEER :

**ARUP**

FAÇADE CONSULTANT:

**ALPHA CONSULTING LIMITED**  
Steel Structure & Façade Specialist

NOTE:

1. ALL DIMENSIONS ARE IN mm.
2. ALL ELEVATIONS ARE VIEWED FROM OUTSIDE.
3. ALL DIMENSIONS TO BE VERIFIED ON SITE BEFORE FABRICATION.

LEGEND:

- ⊗11 --- DETAIL MARK NO.
- ⊗001 --- REFER SHEET NO.
- 1. F.F.L. --- FINISHED FLOOR LEVEL
- 2. S.F.L. --- STRUCTURAL FLOOR LEVEL
- 3. ⊗R --- REVERSED DETAIL
- 4. GLASS LEGEND

EGL-1--8mmHS+12mm AIR GAP+10mmTP THK. I.G.U.  
 EGL-2--10mm THK. CLEAR TEMPERED GLASS  
 EGL-4--10mm THK. TEMPERED ACID ETCHED GLASS  
 EGL-1A--8mmHS+12mm AIR GAP+8mmTP THK. I.G.U.

NO.	DATE	REVISION	SUBJECT TO ARCHITECTMENT	BY
B	29/11/2021	REVISION SUBJECT TO ARCHITECTMENT		WON
A	03/11/2021	REVISION SUBJECT TO ARCHITECTMENT		WON

JOB NO. : J-856

PROJECT : PROPOSED DEVELOPMENT ABOVE LIGHT RAIL TIN WING STOP TSWTL NO.23,AREA 33,TIN SHUI WAI, N.T.

TITLE : WINDOW SCHEDULE FOR TOWER 1 ALUM. WINDOW

DATE : 02-Aug-21 SCALE : 1:40

DRAWN BY : WON CHECKED BY :

**美特經貿有限公司**  
MIDI Aluminium Fabricator Ltd.  
Units 6-8, Sunray Industrial Centre, 1/F  
610 Ona Kwo Ling Road, Kowloon  
Tel:23489211-4 Fax:(852)2727866

DWG NO. : J856-SD-PW-5105 REV. : B

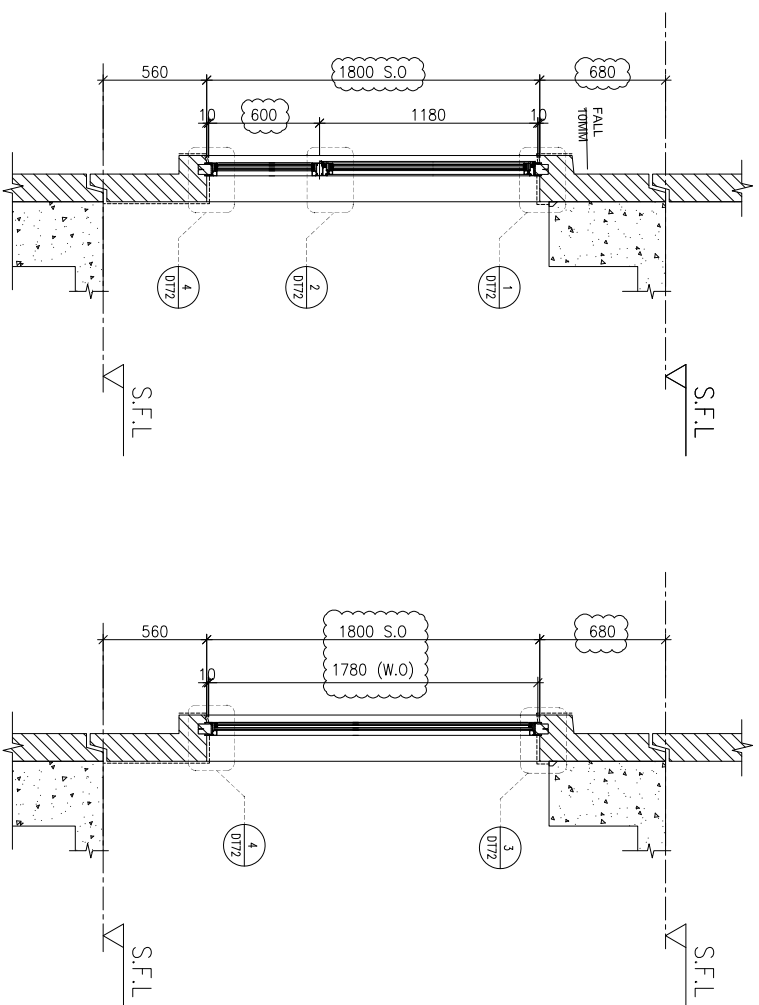
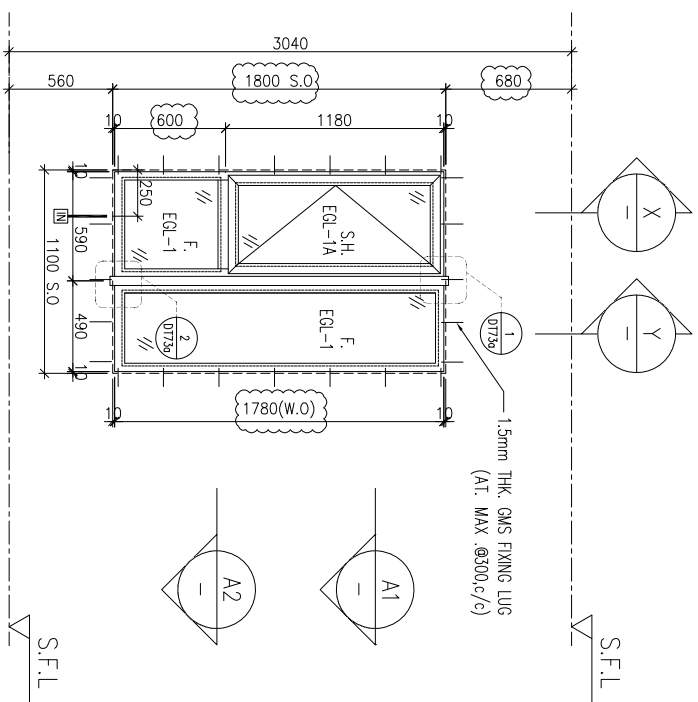

ELEVATION

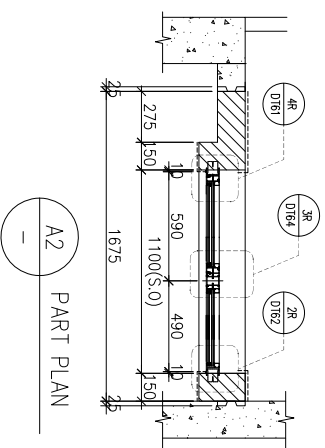
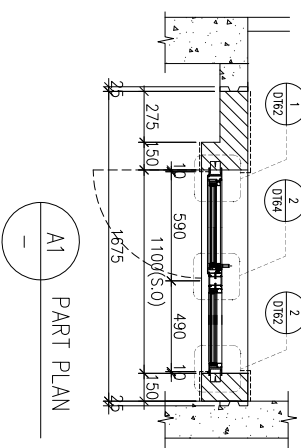

WINDOW MARK	3/F-42/F(4/F,13/F,14/F,24/F,34/F OMITTED) UNIT A7,B2
AW 02	70mm ALUM. SECTION
GLAZING	EGL-1,EGL-1A
QUANTITY	35 Nos / 35 Nos
REMARKS	FAÇADE(TYPE T1PF05R FOR 3/F~42/F)

WINDOW MARK	3/F-42/F(4/F,13/F,14/F,24/F,34/F OMITTED) UNIT A3,A6,A8,B6,B7
AW 02R	70mm ALUM. SECTION
GLAZING	EGL-1,EGL-1A
QUANTITY	35 Nos / 35 Nos / 35 Nos / 35 Nos
REMARKS	FAÇADE(TYPE T1PF05 FOR 3/F~42/F)

B.O. REF :

CLIENT :

**SUN HUNG KAI**  
REAL ESTATE AGENCY LTD.  
42/F SUN HUNG KAI CENTRE, WINGHUA, HONGKONG

ARCHITECT :

**IWK&partners**  
A R C H I T E C T S

MAIN CONTRACTOR :

**怡輝建築有限公司**  
Yee Fai Building Contractors Ltd.

STRUCTURAL ENGINEER :

**ARUP**

FAÇADE CONSULTANT:

**ALPHA CONSULTING LIMITED**  
Steel Structure & Façade Specialist

NOTE :

1. ALL DIMENSIONS ARE IN mm.
2. ALL ELEVATIONS ARE VIEWED FROM OUTSIDE.
3. ALL DIMENSIONS TO BE VERIFIED ON SITE BEFORE FABRICATION.

LEGEND :

- ⊗1 --- DETAIL MARK NO.
- ⊗2001 --- REFER SHEET NO.
- 1. F.F.L. -- FINISHED FLOOR LEVEL
- 2. S.F.L. -- STRUCTURAL FLOOR LEVEL
- 3. ⊗R --- REVERSED DETAIL
- 4. GLASS LEGEND

EGL-1--8mmHS+12mm AIR GAP+10mmTP THK. I.G.U.  
 EGL-2--10mm THK. CLEAR TEMPERED GLASS  
 EGL-4--10mm THK. TEMPERED ACID ETCHED GLASS  
 EGL-1A--8mmHS+12mm AIR GAP+8mmTP THK. I.G.U.

NO.	DATE	REVISION	SUBJECT TO ARCH/COMMENT
C	29/11/2021	REVISION SUBJECT TO ARCH/COMMENT	None
B	03/11/2021	REVISION SUBJECT TO ARCH/COMMENT	None
A	12/10/2021	REVISION SUBJECT TO ARCH/COMMENT	None

JOB NO. : J-856

PROJECT :

PROPOSED DEVELOPMENT ABOVE  
LIGHT RAIL TIN WING STOP-TSWTL  
NO.23,AREA 33,TIN SHUI WAI, N.T.

TITLE :

WINDOW SCHEDULE FOR  
TOWER 1 ALUM. WINDOW

DATE : 02-Aug-21 SCALE : 1:40

DRAWN BY : Iwon CHECKED BY :

**美特經貿有限公司**  
MIDI Aluminium Fabricator Ltd.  
Units 6-8, Sunray Industrial Centre, 1/F  
610 Ona Kwo Ling Road, Kowloon  
Tel:23489211-4 Fax:(852)27277666  
DWG NO. : J856-SD-PW-5106 REV. : C

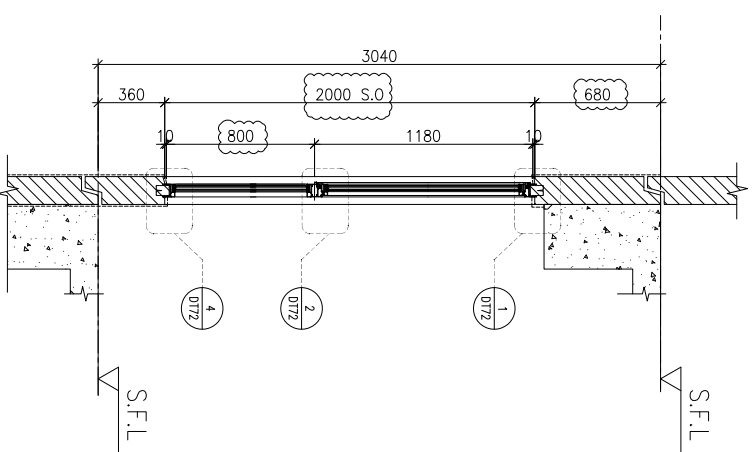
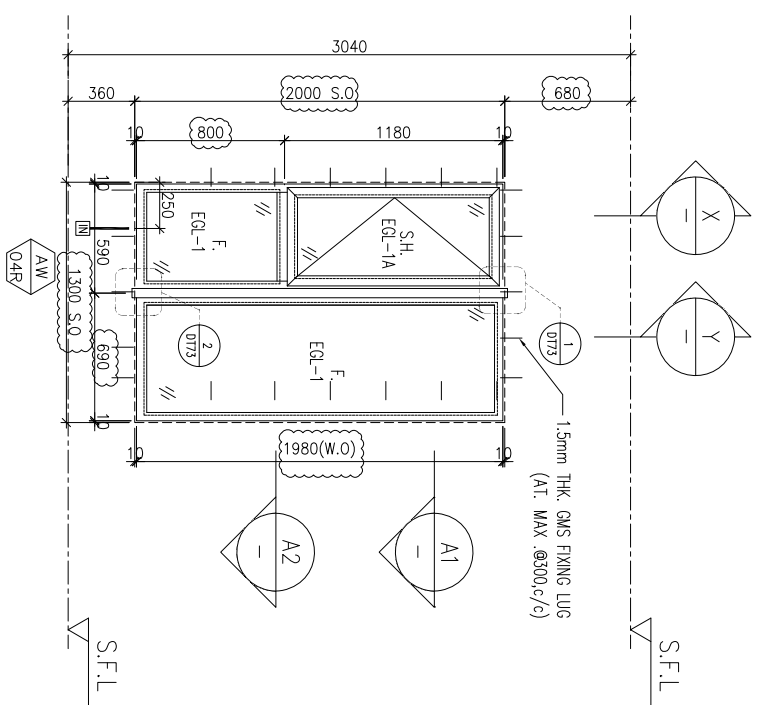

X-X PART SECTION

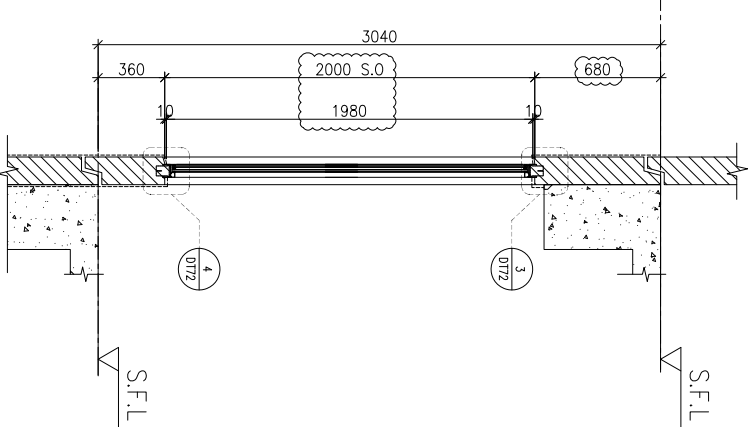

Y-Y PART SECTION

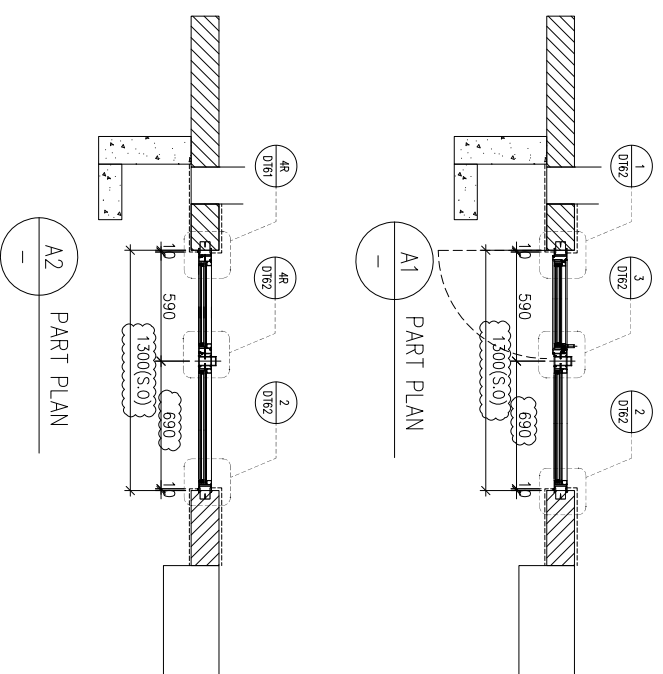

ELEVATION

WINDOW MARK	AW 04R
LOCATION	3/F-42/F(4/F,13/F,14/F,24/F,34/F OMITTED) UNIT A5
SECTION	70mm ALUM. SECTION
GLAZING	EGL-1,EGL-1A
QUANTITY	35 Nos
REMARKS	FAÇADE(TYPE T1PF06R FOR 3/F~42/F)

B.O. REF :

CLIENT :

**SUN HUNG KAI**  
REAL ESTATE AGENCY LTD.  
42/F SUN HUNG KAI CENTRE, WANGCHAI, HONGKONG

ARCHITECT :  
**lwk&partners**  
a r c h i t e c t s

MAIN CONTRACTOR :  
**怡輝建築有限公司**  
Yee Fai Building Contractors Ltd.

STRUCTURAL ENGINEER :  
**ARUP**

FAÇADE CONSULTANT:  
**ALPHA CONSULTING LIMITED**  
Steel Structure & Façade Specialist

NOTE:  
1. ALL DIMENSIONS ARE IN mm.  
2. ALL ELEVATIONS ARE VIEWED FROM OUTSIDE.  
3. ALL DIMENSIONS TO BE VERIFIED ON SITE BEFORE FABRICATION.

LEGEND:

①②③④ — DETAIL MARK NO.  
X001 — REFER SHEET NO.  
1. F.F.L. -- FINISHED FLOOR LEVEL  
2. S.F.L. -- STRUCTURAL FLOOR LEVEL  
3. (R) -- REVERSED DETAIL  
4. GLASS LEGEND

EGL-1 -- 8mmHS+12mm AIR GAP+10mmTP THK. I.G.U.  
EGL-2 -- 10mm THK. CLEAR TEMPERED GLASS  
EGL-4 -- 10mm THK. TEMPERED ACID ETCHED GLASS  
EGL-1A -- 8mmHS+12mm AIR GAP+8mmTP THK. I.G.U.

NO.	DATE	REVISION	SUBJECT TO ARCHITECTMENT	BY
B	29/11/2021	REVISION SUBJECT TO ARCHITECTMENT		WON
A	03/11/2021	REVISION SUBJECT TO ARCHITECTMENT		WON

JOB NO. : J-856  
PROJECT : PROPOSED DEVELOPMENT ABOVE LIGHT RAIL TIN WING STOP TSWTL NO.23, AREA 33, TIN SHUI WAI, N.T.

TITLE : WINDOW SCHEDULE FOR TOWER 1 ALUM. WINDOW

DATE : 02-Aug-21 SCALE : 1:40  
DRAWN BY : WON CHECKED BY :

**美特經貿有限公司**  
MIDI Aluminium Fabricator Ltd.  
Units 6-8, Sunray Industrial Centre, 1/F  
610 Ona Kwo Ling Road, Kwai Tsing  
Tel: 23489211-4 Fax: (852) 2727666  
DWG NO. : J856-SD-PW-5107 REV. : B

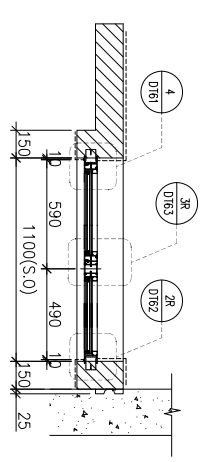
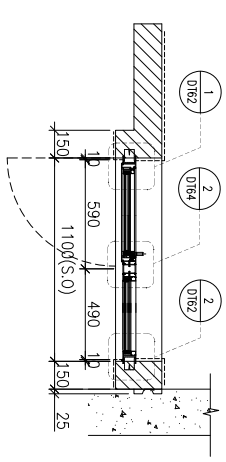
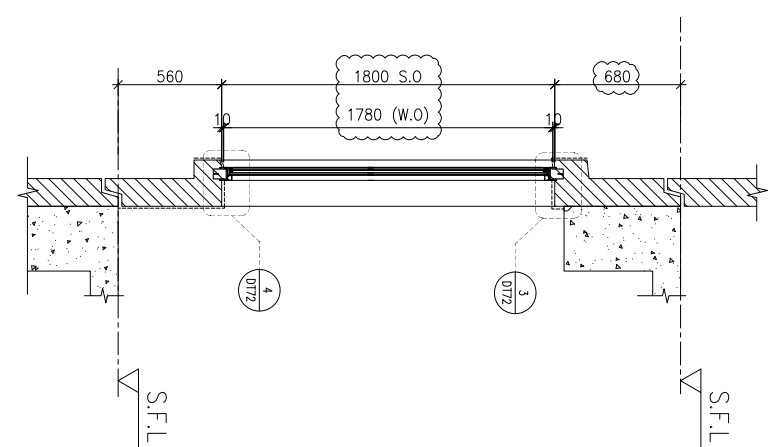
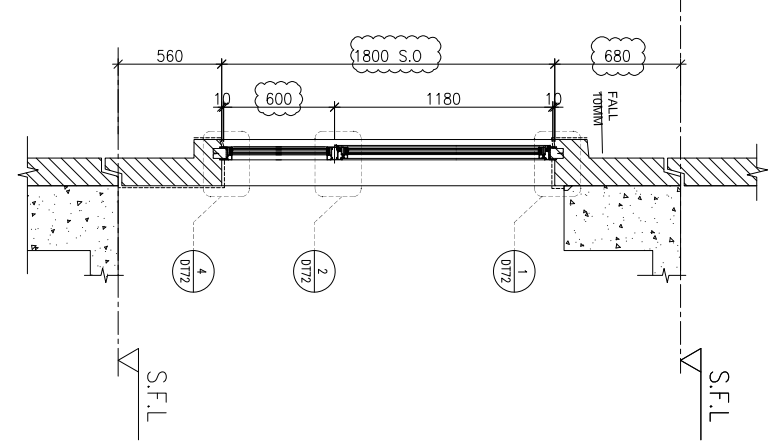
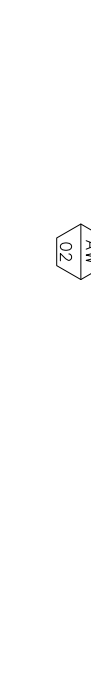
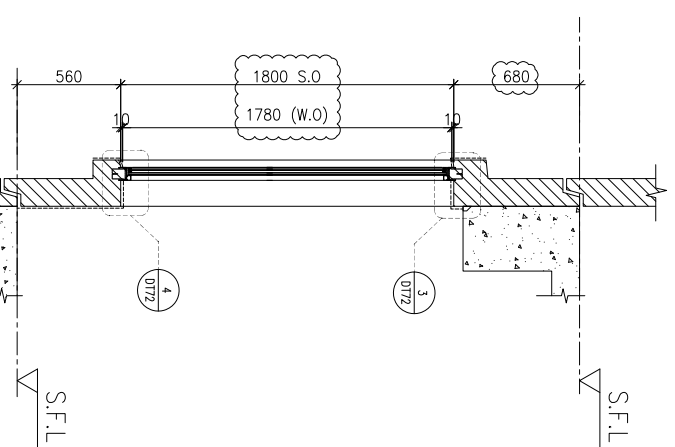
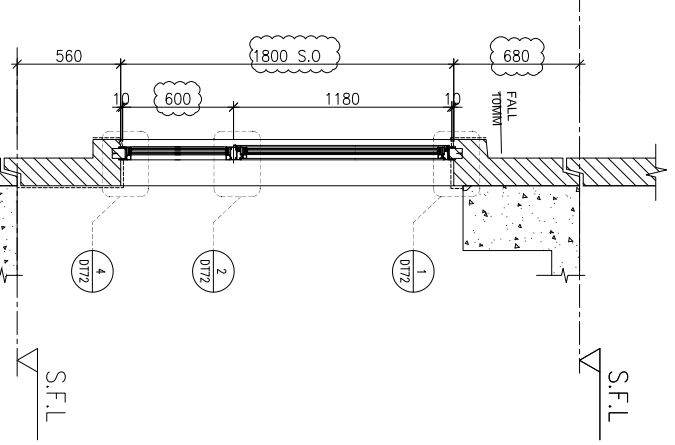
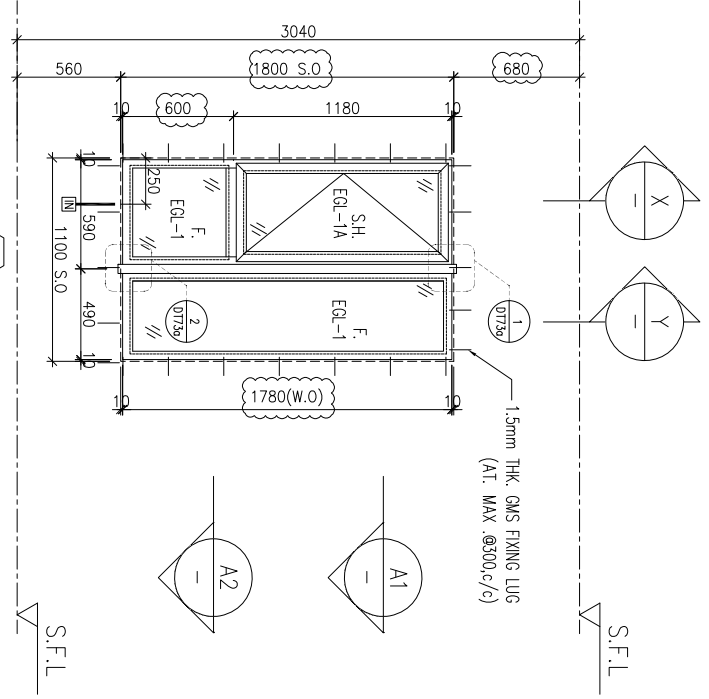

WINDOW MARK	LOCATION	SECTION	QUANTITY	REMARKS
AW 02	3/F-42/F(4/F,13/F,14/F,24/F,34/F OMITTED) UNIT B8	70mm ALUM. SECTION	35 Nos	FAÇADE(TYPE T1PF08R FOR 3/F~42/F)
AW 02R	3/F-42/F(4/F,13/F,14/F,24/F,34/F OMITTED) UNIT A8,B1	70mm ALUM. SECTION	35 Nos / 35 Nos	FAÇADE(TYPE T1PF08R FOR 3/F~42/F)

B.O. REF :

CLIENT :

**SUN HUNG KAI**  
REAL ESTATE AGENCY LTD.

42/F SUN HUNG KAI CENTRE, WANGCHAI, HONGKONG

ARCHITECT :

**lwk&partners**  
a r c h i t e c t s

MAIN CONTRACTOR :

**怡輝建築有限公司**  
Yee Fai Building Contractors Ltd.

STRUCTURAL ENGINEER :

**ARUP**

FAÇADE CONSULTANT:

**ALPHA CONSULTING LIMITED**  
Steel Structure & Façade Specialist

NOTE :

1. ALL DIMENSIONS ARE IN mm.
2. ALL ELEVATIONS ARE VIEWED FROM OUTSIDE.
3. ALL DIMENSIONS TO BE VERIFIED ON SITE BEFORE FABRICATION.

LEGEND :

⊗1—DETAIL MARK NO.  
X001—REFER SHEET NO.

1. F.F.L.--FINISHED FLOOR LEVEL
2. S.F.L.--STRUCTURAL FLOOR LEVEL
3. (R) --REVERSED DETAIL
4. GLASS LEGEND

EGL-1--8mmHS+12mm AIR GAP+10mmTP THK. I.G.U.  
EGL-2--10mm THK. CLEAR TEMPERED GLASS  
EGL-4--10mm THK. TEMPERED ACID ETCHED GLASS  
EGL-14--8mmHS+12mm AIR GAP+8mmTP THK. I.G.U.

NO.	DATE	REVISION	SUBJECT TO ARCH/COMMENT
B	29/11/2021	REVISION SUBJECT TO ARCH/COMMENT	WON
A	03/11/2021	REVISION SUBJECT TO ARCH/COMMENT	WON

JOB NO. : J-856

PROJECT :

PROPOSED DEVELOPMENT ABOVE  
LIGHT RAIL TIN WING STOP TSWTL  
NO.23,AREA 33,TIN SHUI WAI, N.T.

TITLE :

WINDOW SCHEDULE FOR  
TOWER 1 ALUM. WINDOW

DATE : 02-Aug-21 SCALE : 1:40

DRAWN BY : Iwon CHECKED BY :

**美特經貿有限公司**  
MIDI Aluminium Fabricator Ltd.

Units 6-8, Sunray Industrial Centre, 1/F  
610 Ona Kwo Ling Road, Kowloon  
Tel:23489211-4 Fax:(852)2727866

DWG NO. : J856-SD-PW-5108 REV. : B

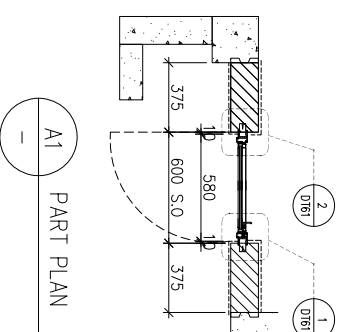
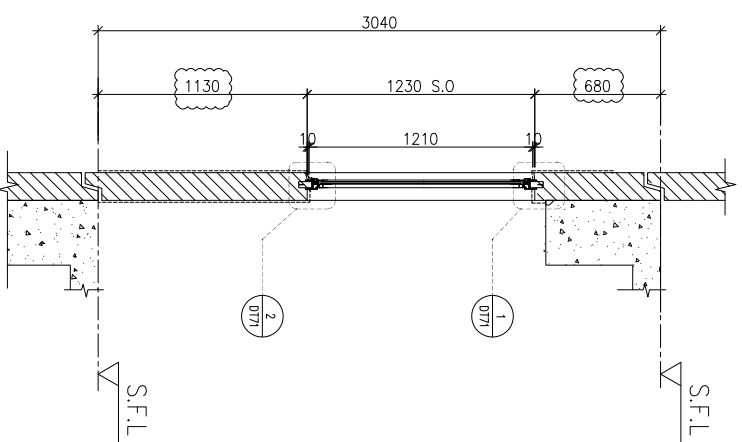
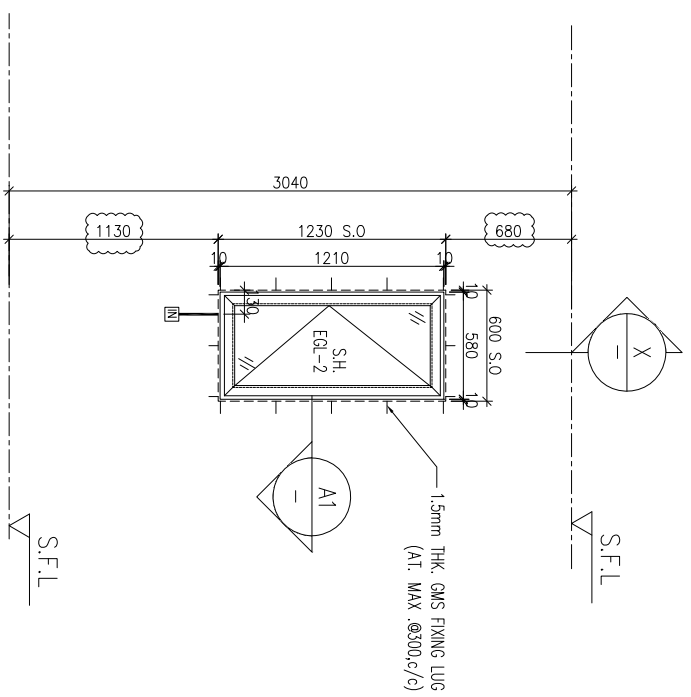

ELEVATION

WINDOW MARK	AW 06
LOCATION	3/F-42/F(4/F,13/F,14/F,24/F,34/F OMITTED) UNIT B3
SECTION	70mm ALUM. SECTION
GLAZING	EGL-2
QUANTITY	35 Nos
REMARKS	FAÇADE(TYPE T1PF09 FOR 3/F~42/F)

NO.	DATE	REVISION	SUBJECT TO ARCHITECTMENT
C	29/11/2021	REVISION SUBJECT TO ARCHITECTMENT	None
B	03/11/2021	REVISION SUBJECT TO ARCHITECTMENT	None
A	12/10/2021	REVISION SUBJECT TO ARCHITECTMENT	None

ELEVATION

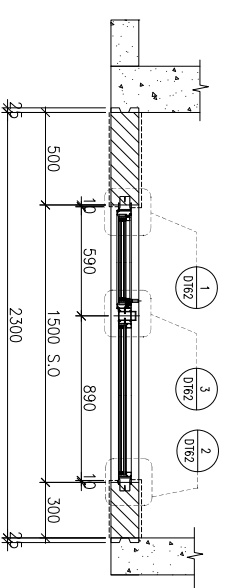
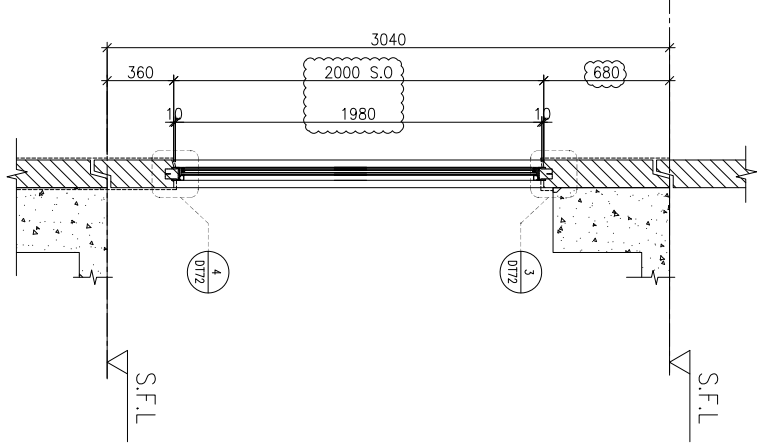
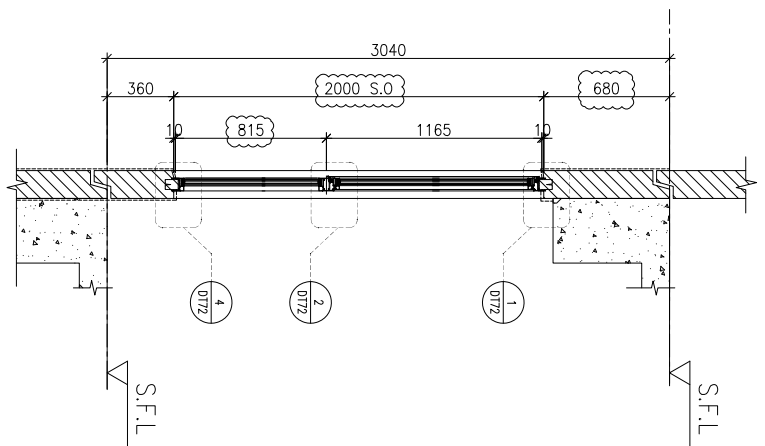
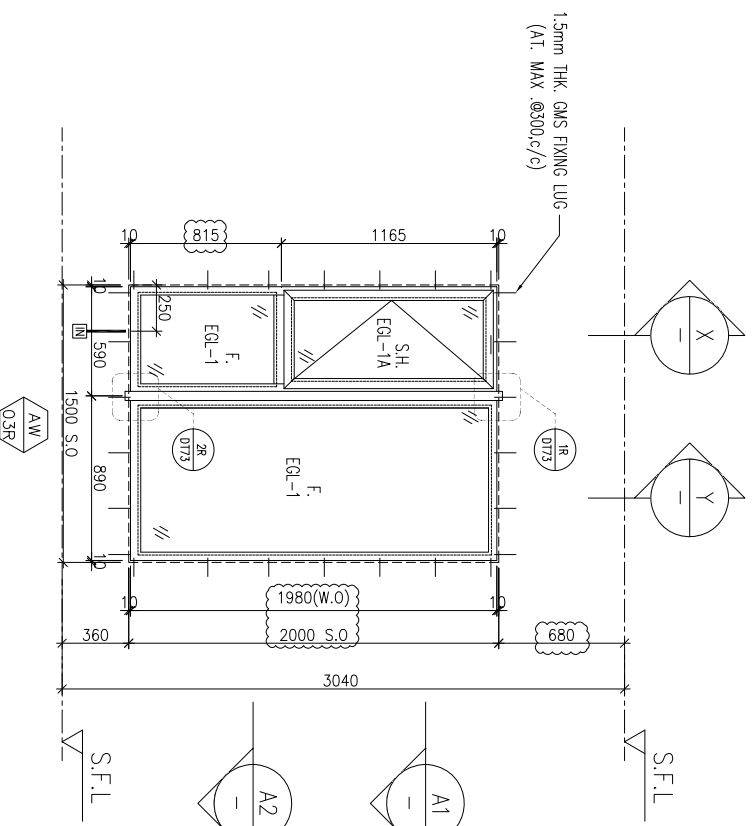

A1 PART PLAN

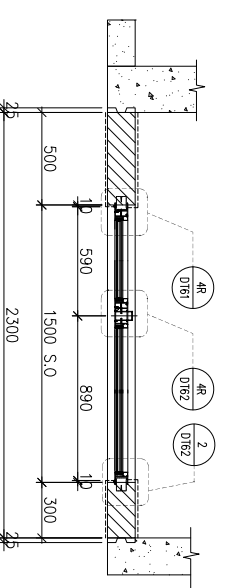

A2 PART PLAN

WINDOW MARK	AW Q3R
LOCATION	3/F-42/F(4/F,13/F,14/F,24/F,34/F OMITTED) UNIT B3
SECTION	70mm ALUM. SECTION
GLAZING	EGL-1,EGL-1A
QUANTITY	35 Nos
REMARKS	FAÇADE TYPE T1PF10 FOR 3/F~42/F)

B.O. REF :

CLIENT :

**SUN HUNG KAI**  
REAL ESTATE AGENCY LTD.  
42/F SUN HUNG KAI CENTRE, WANGCHAI, HONGKONG

ARCHITECT :

**IWK&partners**  
A R C H I T E C T S

MAIN CONTRACTOR :

**怡輝建築有限公司**  
Yee Fai Building Contractors Ltd.

STRUCTURAL ENGINEER :

**ARUP**

FAÇADE CONSULTANT:

**ALPHA CONSULTING LIMITED**  
Steel Structure & Façade Specialist

NOTE :

1. ALL DIMENSIONS ARE IN mm.
2. ALL ELEVATIONS ARE VIEWED FROM OUTSIDE.
3. ALL DIMENSIONS TO BE VERIFIED ON SITE BEFORE FABRICATION.

LEGEND :

⊗11 --- DETAIL MARK NO.  
⊗001 --- REFER SHEET NO.

1. F.F.L. -- FINISHED FLOOR LEVEL
2. S.F.L. -- STRUCTURAL FLOOR LEVEL
3. ⊗R --- REVERSED DETAIL
4. GLASS LEGEND

EGL-1--8mmHS+12mm AIR GAP+10mmTP THK. I.G.U.  
EGL-2--10mm THK. CLEAR TEMPERED GLASS  
EGL-4--10mm THK. TEMPERED ACID ETCHED GLASS  
EGL-1A--8mmHS+12mm AIR GAP+8mmTP THK. I.G.U.

NO.	DATE	REVISION	REVISION SUBJECT TO ARCHITECTMENT
C	29/11/2021		REVISION SUBJECT TO ARCHITECTMENT
B	03/11/2021		REVISION SUBJECT TO ARCHITECTMENT
A	12/10/2021		REVISION SUBJECT TO ARCHITECTMENT

JOB NO. : J-856

PROJECT :

PROPOSED DEVELOPMENT ABOVE  
LIGHT RAIL TIN WING STOP-TSWTL  
NO.23,AREA 33,TIN SHUI WAI, N.T.

TITLE :

WINDOW SCHEDULE FOR  
TOWER 1 ALUM. WINDOW

DATE : 02-Aug-21 SCALE : 1:40

DRAWN BY : Ivon CHECKED BY :

**美特經貿有限公司**  
MIDI Aluminium Fabricator Ltd.  
Units 6-8, Sunray Industrial Centre, 1/F  
610 Ona Kwo Ling Road, Kowloon  
Tel:23489211-4 Fax:(852)2727666

DWG NO. : J856-SD-PW-5110 REV. : C

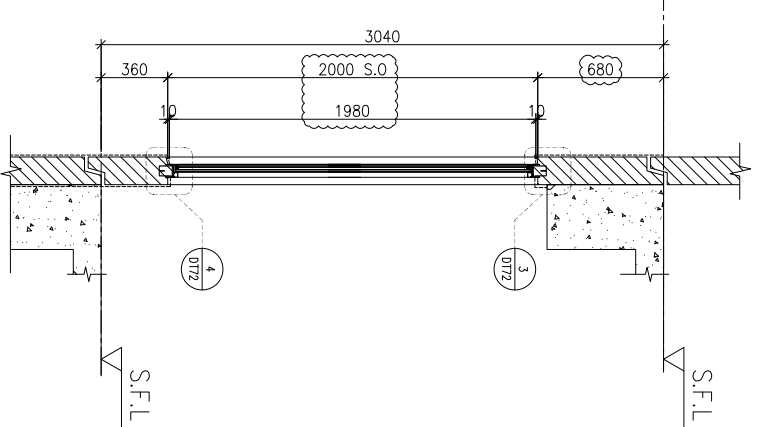
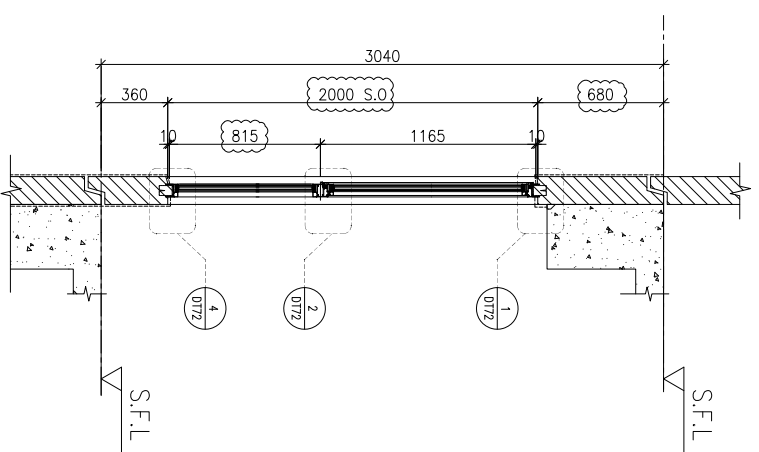
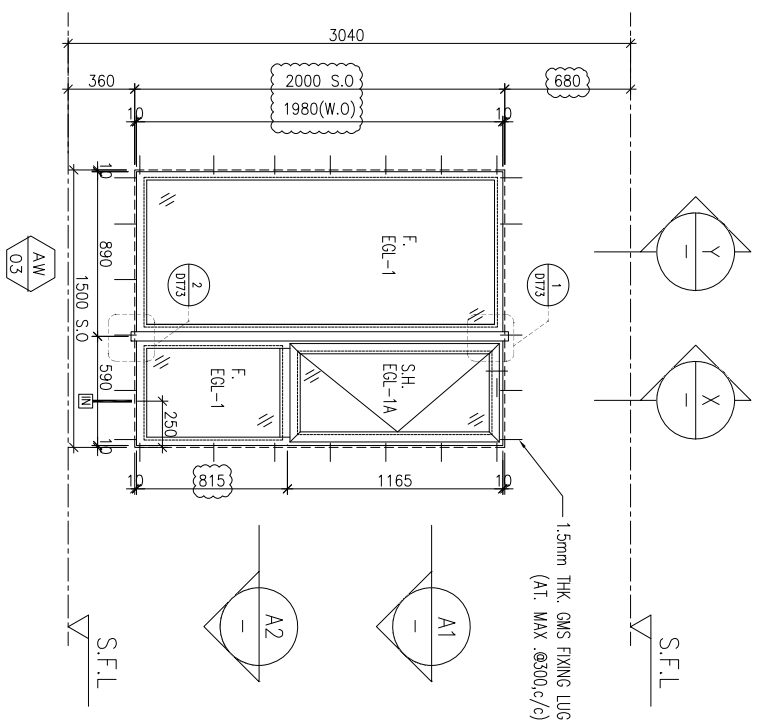

ELEVATION

A1 PART PLAN

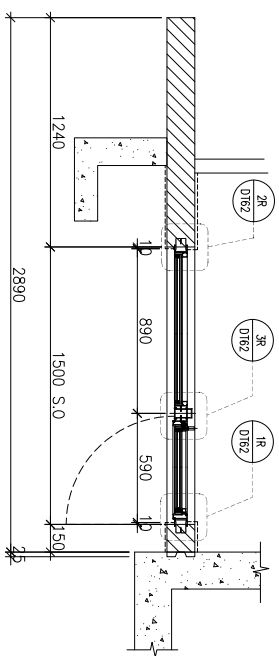

A2 PART PLAN

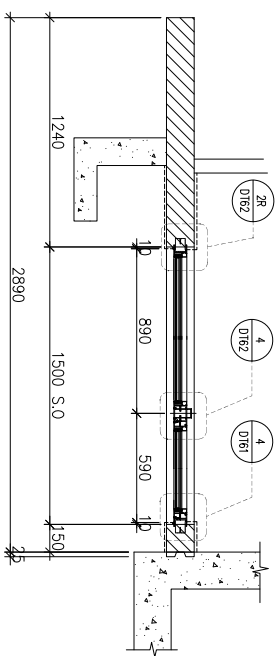

WINDOW MARK  
AW  
03R

LOCATION  
3/F-42/F(4/F,13/F,14/F,24/F,34/F OMITTED) UNIT B5

SECTION  
70mm ALUM. SECTION

GLAZING  
EGL-1,EGL-1A

QUANTITY  
35 Nos

REMARKS  
FAÇADE(TYPE T1PF11R FOR 3/F~42/F)

B.O. REF :

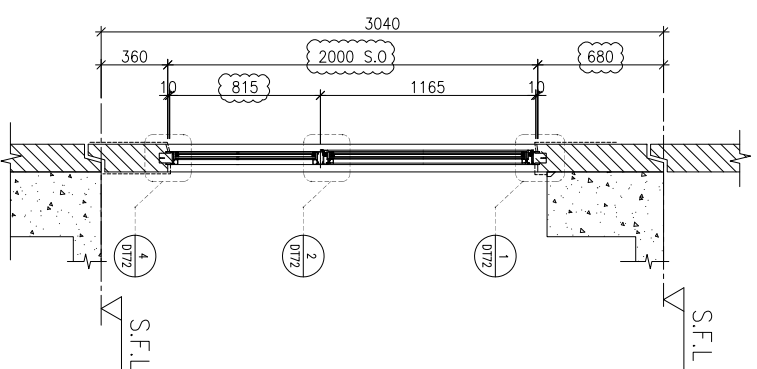
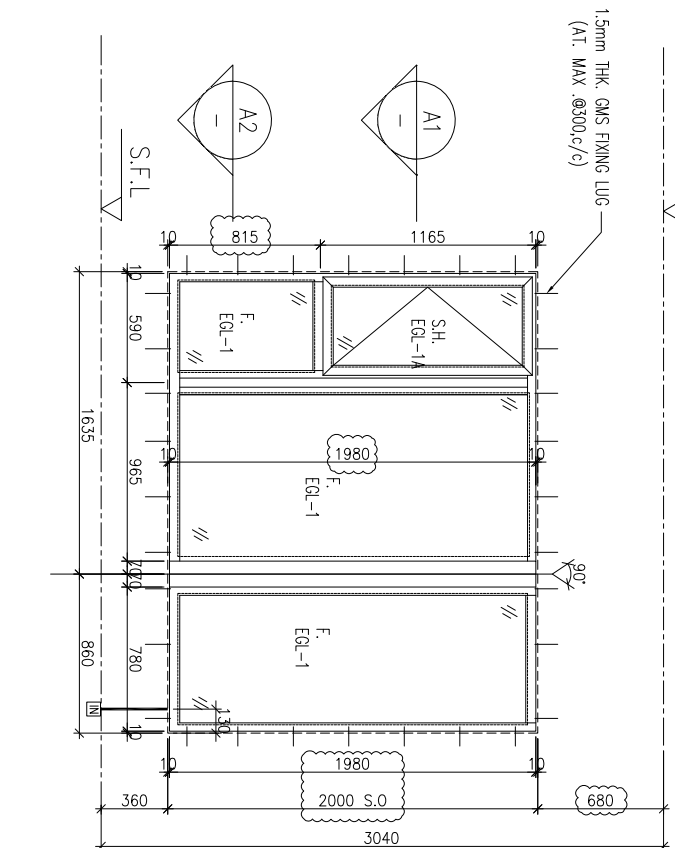
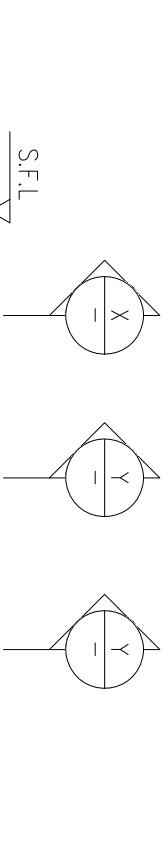

X-X PART SECTION

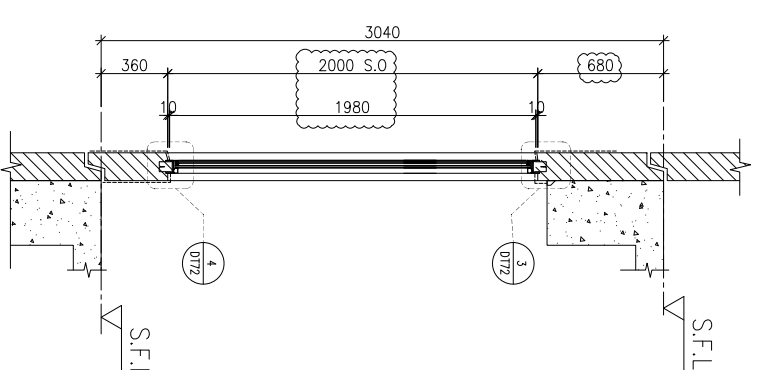

Y-Y PART SECTION

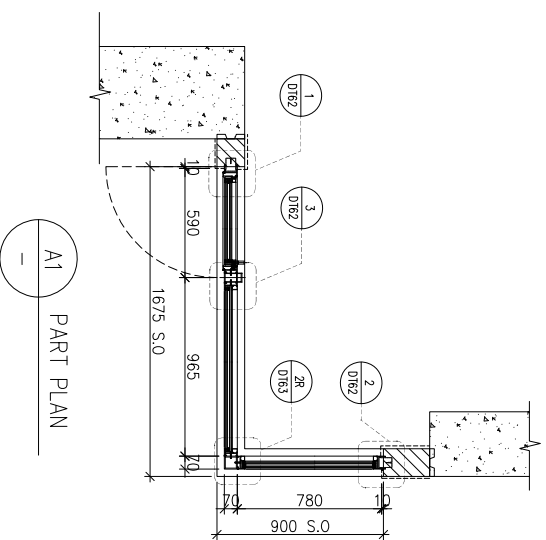

A1 PART PLAN

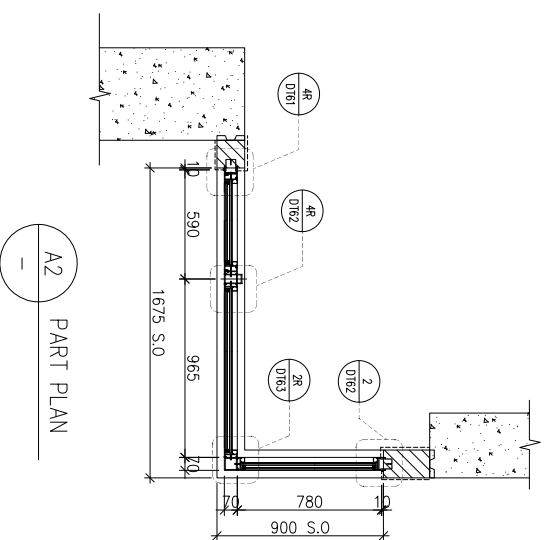

A2 PART PLAN

CLIENT :  
**SUN HUNG KAI**  
 REAL ESTATE AGENCY LTD.  
 42/F SUN HUNG KAI CENTRE, WINGHUA, HONGKONG

ARCHITECT :  
**lw&partners**  
 a r c h i t e c t s

MAIN CONTRACTOR :  
**怡輝建築有限公司**  
 Yee Fai Building Contractors Ltd.

STRUCTURAL ENGINEER :  
**ARUP**  
 ALPHA CONSULTING LIMITED  
 Steel Structure & Facade Specialist

FAÇADE CONSULTANT:

NOTE:  
 1. ALL DIMENSIONS ARE IN mm.  
 2. ALL ELEVATIONS ARE VIEWED FROM OUTSIDE.  
 3. ALL DIMENSIONS TO BE VERIFIED ON SITE BEFORE FABRICATION.

LEGEND:  
 (X1) DETAIL MARK NO.  
 (X001) REFER SHEET NO.

1. F.F.L.--FINISHED FLOOR LEVEL  
 2. S.F.L.--STRUCTURAL FLOOR LEVEL  
 3. (R) --REVERSED DETAIL  
 4. GLASS LEGEND  
 EQL-1--8mmHS+12mm AIR GAP+10mmTP THK. I.G.U.  
 EQL-2--10mm THK. CLEAR TEMPERED GLASS  
 EQL-4--10mm THK. TEMPERED ACID ETCHED GLASS  
 EQL-1A--8mmHS+12mm AIR GAP+8mmTP THK. I.G.U.

NO.	DATE	REVISION	SUBJECT TO AMENDMENT
C	29/11/2021	REVISION SUBJECT TO AMENDMENT	None
B	03/11/2021	REVISION SUBJECT TO AMENDMENT	None
A	12/10/2021	REVISION SUBJECT TO AMENDMENT	None

JOB NO. : J-856

PROJECT :  
 PROPOSED DEVELOPMENT ABOVE  
 LIGHT RAIL TIN WING STOP TSWTL  
 NO.23,AREA 33,TIN SHUI WAI, N.T.

TITLE :  
 WINDOW SCHEDULE FOR  
 TOWER 1 ALUM. WINDOW

DATE : 02-Aug-21 SCALE : 1:40  
 DRAWN BY : Ivon CHECKED BY :  
**美特鋁質有限公司**  
 MIDU ALUMINIUM FABRICATOR LTD.  
 Units 6-8, Sunray Industrial Centre, 1/F  
 610 Ona Kwo Ling Road, Kowloon  
 Tel:23489211-4 Fax:(852)2727666  
 DWG NO. : J856-SD-PW-5111 REV. : C

ELEVATION

WINDOW MARK	AW 07
LOCATION	3/F-42/F(4/F,13/F,14/F,24/F,34/F OMITTED) UNIT B8
SECTION	70mm ALUM. SECTION
GLAZING	EGL-1,EGL-1A
QUANTITY	35 Nos
REMARKS	FAÇADE(TYPE T1PF12 FOR 3/F~42/F)

B.O. REF :

CLIENT :

**SUN HUNG KAI**  
**REAL ESTATE AGENCY LTD.**  
 42/F SUN HUNG KAI CENTRE, WINGHUA, HONGKONG

ARCHITECT :  
**lwk&partners**  
 a r c h i t e c t s

MAIN CONTRACTOR :  
**怡輝建築有限公司**  
**Yee Fai Building Contractors Ltd.**

STRUCTURAL ENGINEER :  
**ARUP**

FAÇADE CONSULTANT:  
**ALPHA CONSULTING LIMITED**  
 Steel Structure & Façade Specialist

NOTE:  
 1. ALL DIMENSIONS ARE IN mm.  
 2. ALL ELEVATIONS ARE VIEWED FROM OUTSIDE.  
 3. ALL DIMENSIONS TO BE VERIFIED ON SITE BEFORE FABRICATION.

LEGEND:

⊗1 — DETAIL MARK NO.  
 X001 — REFER SHEET NO.  
 1. F.F.L. -- FINISHED FLOOR LEVEL  
 2. S.F.L. -- STRUCTURAL FLOOR LEVEL  
 3. ↺ -- REVERSED DETAIL  
 4. GLASS LEGEND

EGL-1--8mmHS+12mm AIR GAP+10mmTP THK. I.G.U.  
 EGL-2--10mm THK. CLEAR TEMPERED GLASS  
 EGL-4--10mm THK. TEMPERED ACID ETCHED GLASS  
 EGL-1A--8mmHS+12mm AIR GAP+8mmTP THK. I.G.U.

NO.	DATE	REVISION	SUBJECT TO ARCHITECTMENT
C	29/11/2021	REVISION SUBJECT TO ARCHITECTMENT	None
B	03/11/2021	REVISION SUBJECT TO ARCHITECTMENT	None
A	12/10/2021	REVISION SUBJECT TO ARCHITECTMENT	None

JOB NO. : J-856

PROJECT :  
 PROPOSED DEVELOPMENT ABOVE  
 LIGHT RAIL TIN WING STOP TSWTL  
 NO.23,AREA 33,TIN SHUI WAI, N.T.

TITLE :  
 WINDOW SCHEDULE FOR  
 TOWER 2 ALUM. WINDOW

DATE : 02-Aug-21 SCALE : 1:40

DRAWN BY : Iwon CHECKED BY :

**美特經貿有限公司**  
**MIDI Aluminium Fabricator Ltd.**  
 Units 6-8, Sunray Industrial Centre, 1/F  
 610 Ona Kwo Ling Road, Kowloon  
 Tel:23489211-4 Fax:(852)2727666  
 DWG NO. : J856-SD-PW-5201 REV. : C

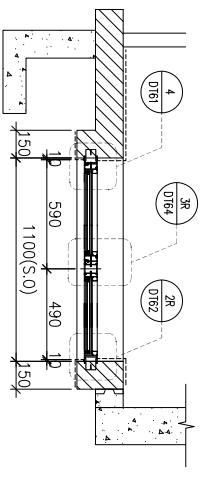
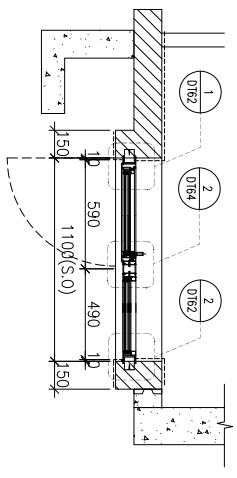
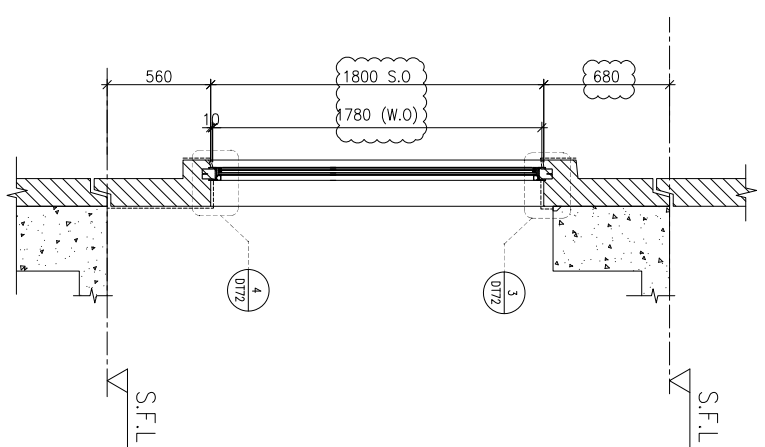
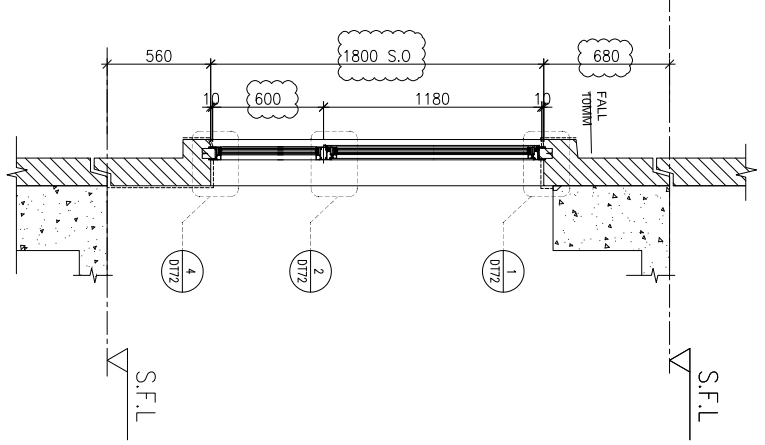
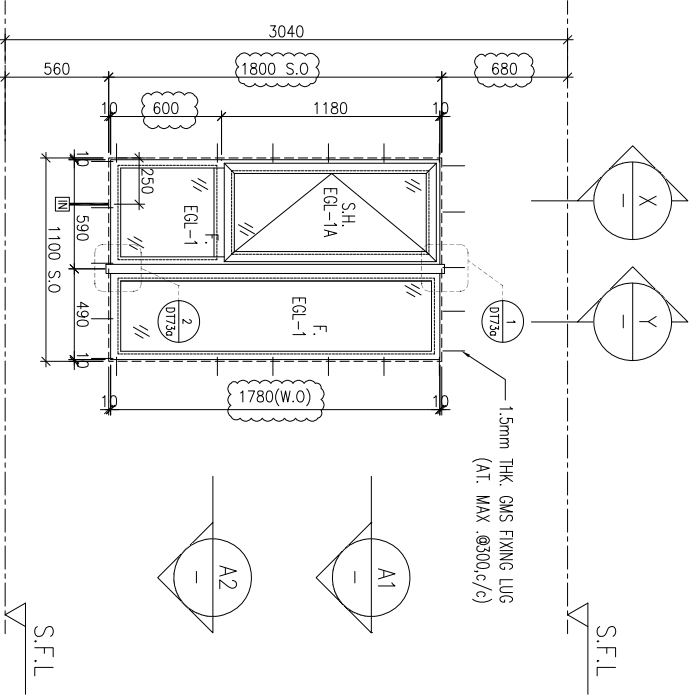

WINDOW MARK	AW 02R
LOCATION	3/F-42/F(4/F,13/F,14/F,24/F,34/F OMITTED) UNIT A1
SECTION	70mm ALUM. SECTION
GLAZING	EGL-1,EGL-1A
QUANTITY	35 Nos.
REMARKS	FAÇADE(TYPE T2PF01R FOR 3/F~42/F)

A1 PART PLAN  
 A2 PART PLAN

ELEVATION

B.O. REF :

CLIENT :

**SUN HUNG KAI**  
REAL ESTATE AGENCY LTD.  
42/F SUN HUNG KAI CENTRE, WINGHAI, HONGKONG

ARCHITECT :

**Iwk&partners**  
A R C H I T E C T S

MAIN CONTRACTOR :

**怡輝建築有限公司**  
Yee Fai Building Contractors Ltd.

STRUCTURAL ENGINEER :

**ARUP**

FAÇADE CONSULTANT:

**ALPHA CONSULTING LIMITED**  
Steel Structure & Façade Specialist

NOTE :

1. ALL DIMENSIONS ARE IN mm.
2. ALL ELEVATIONS ARE VIEWED FROM OUTSIDE.
3. ALL DIMENSIONS TO BE VERIFIED ON SITE BEFORE FABRICATION.

LEGEND :

⊗1 --- DETAIL MARK NO.  
⊗001 --- REFER SHEET NO.

1. F.F.L. --- FINISHED FLOOR LEVEL

2. S.F.L. --- STRUCTURAL FLOOR LEVEL

3. ⊗R --- REVERSED DETAIL

4. GLASS LEGEND

EGL-1 --- 8mmHS+12mm AIR GAP+10mmTP THK. I.G.U.

EGL-2 --- 10mm THK. CLEAR TEMPERED GLASS

EGL-4 --- 10mm THK. TEMPERED ACID ETCHED GLASS

EGL-1A --- 8mmHS+12mm AIR GAP+8mmTP THK. I.G.U.

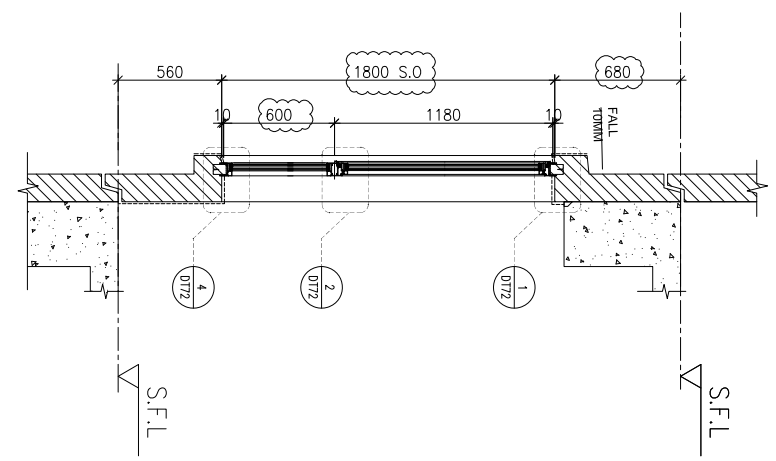
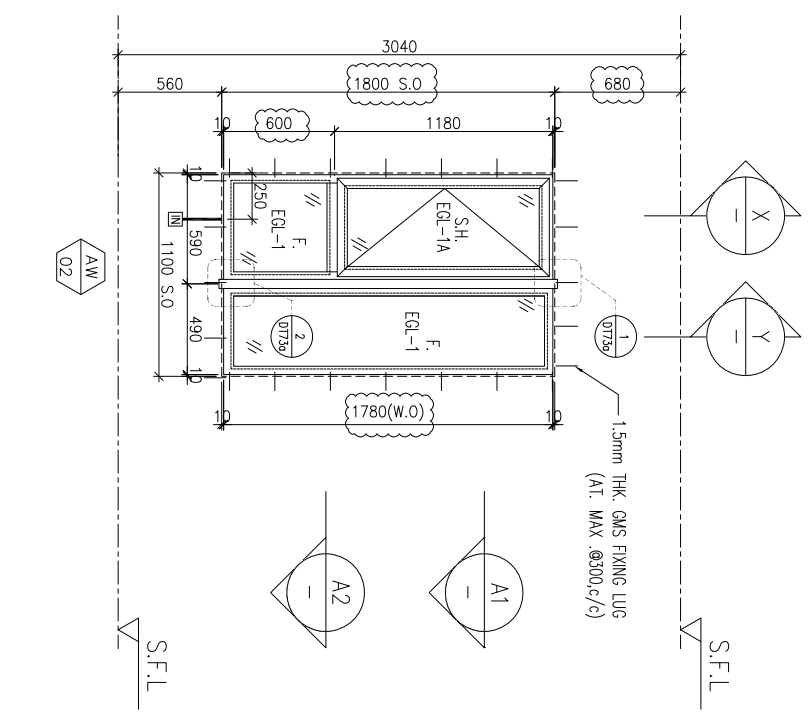

⊗ X --- PART SECTION

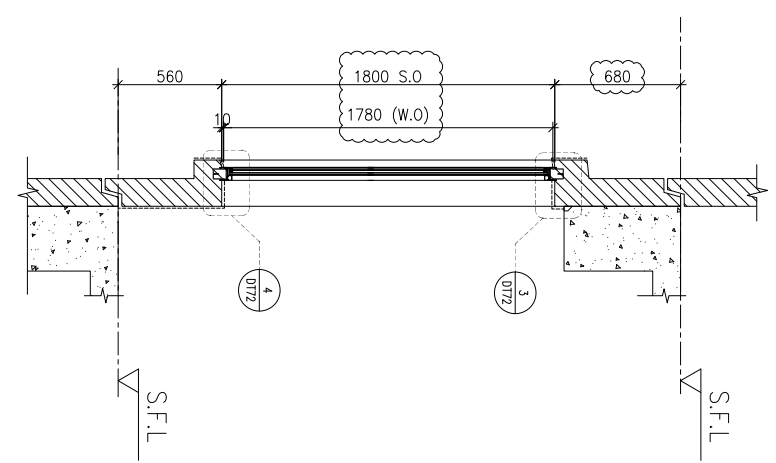

⊗ Y --- PART SECTION

ELEVATION

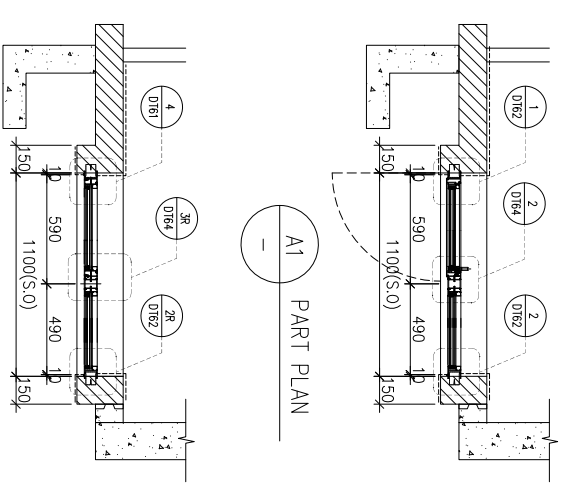

⊗ A1 --- PART PLAN

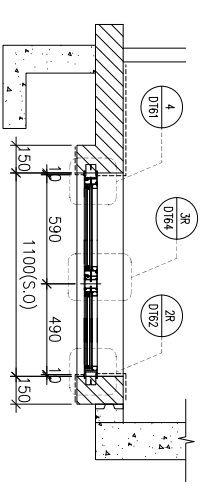

⊗ A2 --- PART PLAN

WINDOW MARK	AW 02	AW 02R
LOCATION	3/F-42/F(4/F,13/F,14/F,24/F,34/F OMITTED) UNIT B3	3/F-42/F(4/F,13/F,14/F,24/F,34/F OMITTED) UNIT A2,A5
SECTION	70mm ALUM. SECTION	70mm ALUM. SECTION
GLAZING	EGL-1,EGL-1A	EGL-1,EGL-1A
QUANTITY	35 Nos.	35 Nos / 35 Nos.
REMARKS	FAÇADE(TYPE T2PF02 FOR 3/F~42/F)	FAÇADE(TYPE T2PF02R FOR 3/F~42/F)

DATE :	02-Aug-21	SCALE :	1:40												
DRAWN BY :	von	CHECKED BY :													
<p>PROJECT : PROPOSED DEVELOPMENT ABOVE LIGHT RAIL TIN WING STOP TSWTL NO.23,AREA 33,TIN SHUI WAI, N.T.</p> <p>TITLE : WINDOW SCHEDULE FOR TOWER 2 ALUM. WINDOW</p>															
JOB NO. :	J-856														
<p>REVISION SUBJECT TO ARCHITECTMENT</p> <table border="1"> <thead> <tr> <th>NO.</th> <th>DATE</th> <th>REVISION</th> <th>BY</th> </tr> </thead> <tbody> <tr> <td>B</td> <td>29/11/2021</td> <td>REVISION SUBJECT TO ARCHITECTMENT</td> <td>von</td> </tr> <tr> <td>A</td> <td>03/11/2021</td> <td>REVISION SUBJECT TO ARCHITECTMENT</td> <td>von</td> </tr> </tbody> </table>				NO.	DATE	REVISION	BY	B	29/11/2021	REVISION SUBJECT TO ARCHITECTMENT	von	A	03/11/2021	REVISION SUBJECT TO ARCHITECTMENT	von
NO.	DATE	REVISION	BY												
B	29/11/2021	REVISION SUBJECT TO ARCHITECTMENT	von												
A	03/11/2021	REVISION SUBJECT TO ARCHITECTMENT	von												
<p>Units 6-8, Sunray Industrial Centre, 1/F 610 Ona Kwo Ling Road, Kowloon Tel:23489211-4 Fax:(852)2727866</p> <p><b>美特經貿有限公司</b> MIDI Aluminium Fabricator Ltd.</p> <p>DWG NO. : J856-SD-PW-5202 REV. : B</p>															

B.O. REF :

CLIENT :

**SUN HUNG KAI**  
REAL ESTATE AGENCY LTD.  
42/F SUN HUNG KAI CENTRE, WINGLOH, HONGKONG

ARCHITECT :  
**Ykk&partners**  
A R C H I T E C T S

MAIN CONTRACTOR :  
**Ykk** 怡輝建築有限公司  
Yee Fai Building Contractors Ltd.

STRUCTURAL ENGINEER :  
**ARUP**

FAÇADE CONSULTANT:  
**ALPHA CONSULTING LIMITED**  
Steel Structure & Façade Specialist

NOTE:  
1. ALL DIMENSIONS ARE IN mm.  
2. ALL ELEVATIONS ARE VIEWED FROM OUTSIDE.  
3. ALL DIMENSIONS TO BE VERIFIED ON SITE BEFORE FABRICATION.

LEGEND:

- (X1) DETAIL MARK NO.
- (X001) REFER SHEET NO.
- 1. F.F.L.--FINISHED FLOOR LEVEL
- 2. S.F.L.--STRUCTURAL FLOOR LEVEL
- 3. (R) --REVERSED DETAIL
- 4. GLASS LEGEND

EGL-1--8mmHS+12mm AIR GAP+10mmTP THK. I.G.U.  
EGL-2--10mm THK. CLEAR TEMPERED GLASS  
EGL-4--10mm THK. TEMPERED ACID ETCHED GLASS  
EGL-1A--8mmHS+12mm AIR GAP+8mmTP THK. I.G.U.

NO.	DATE	REVISION	SUBJECT TO ARCH/COMMENT
B	29/11/2021	REVISION SUBJECT TO ARCH/COMMENT	WON
A	03/11/2021	REVISION SUBJECT TO ARCH/COMMENT	WON

JOB NO. : J-8556  
PROJECT : PROPOSED DEVELOPMENT ABOVE LIGHT RAIL TIN WING STOP-TSWTL NO.23,AREA 33,TIN SHUI WAI, N.T.

TITLE : WINDOW SCHEDULE FOR TOWER 2 ALUM. WINDOW

DATE : 02-Aug-21 SCALE : 1:40  
DRAWN BY : Iwon CHECKED BY :

**MIDI** 美特經貿有限公司  
ALUMINIUM FABRICATOR LTD.  
Units 6-8, Sunray Industrial Centre, 1/F  
610 Ona Kwo Ling Road, Kowloon  
Tel:23489211-4 Fax:(852)27277666  
DWG NO. : J856-SD-PW-5203 REV. : B

ELEVATION

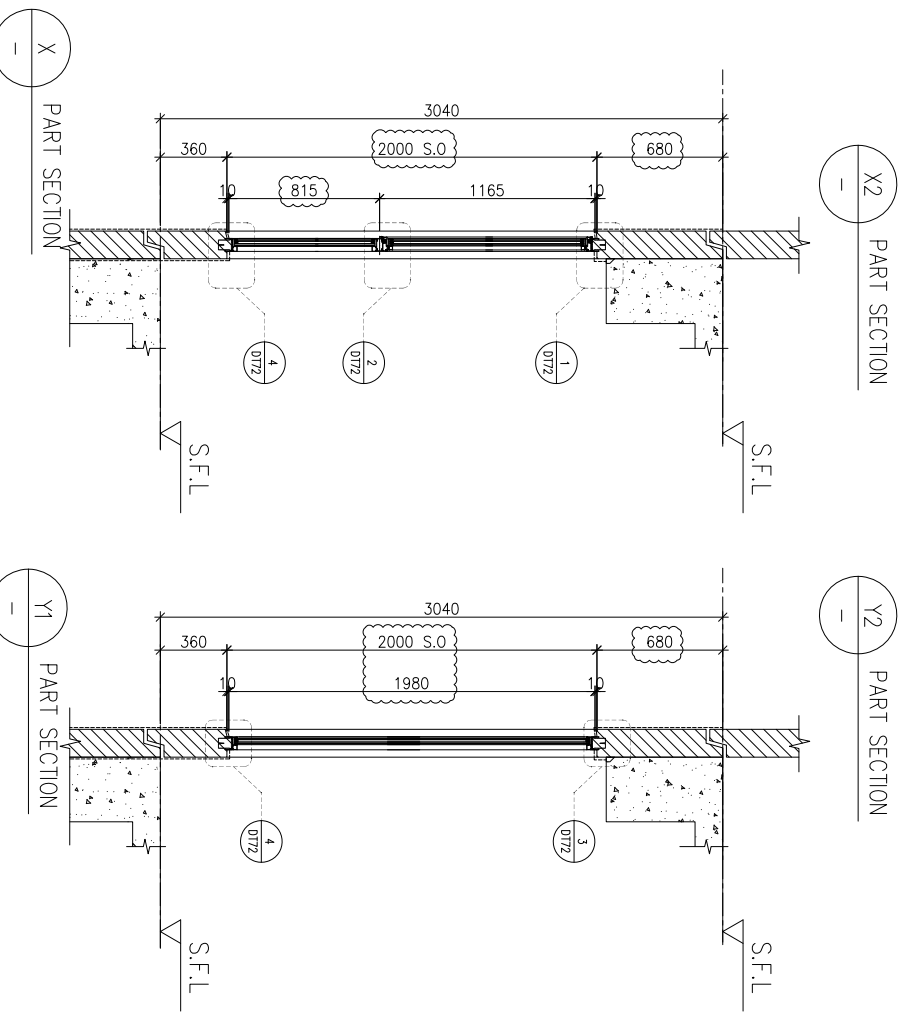
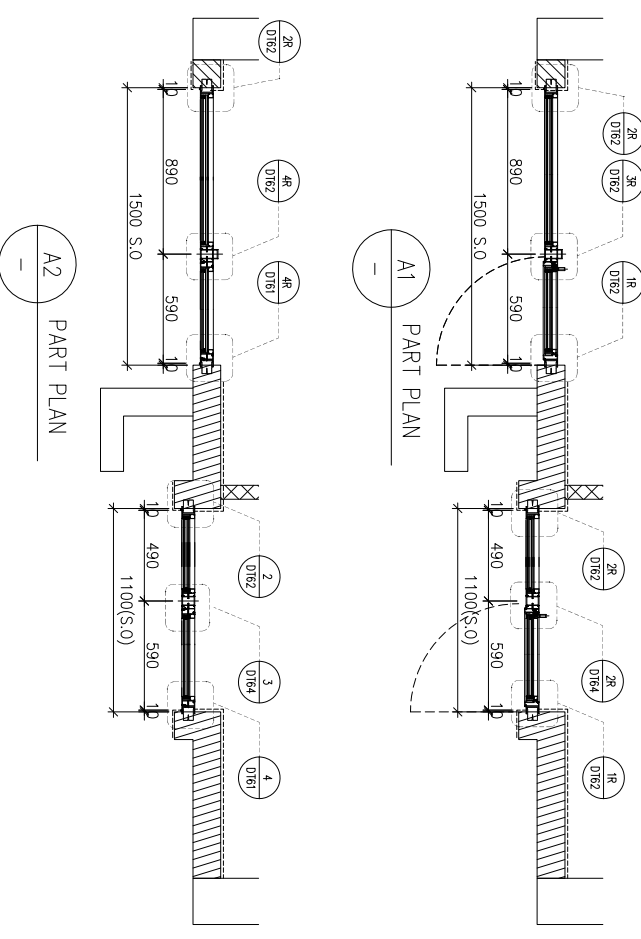
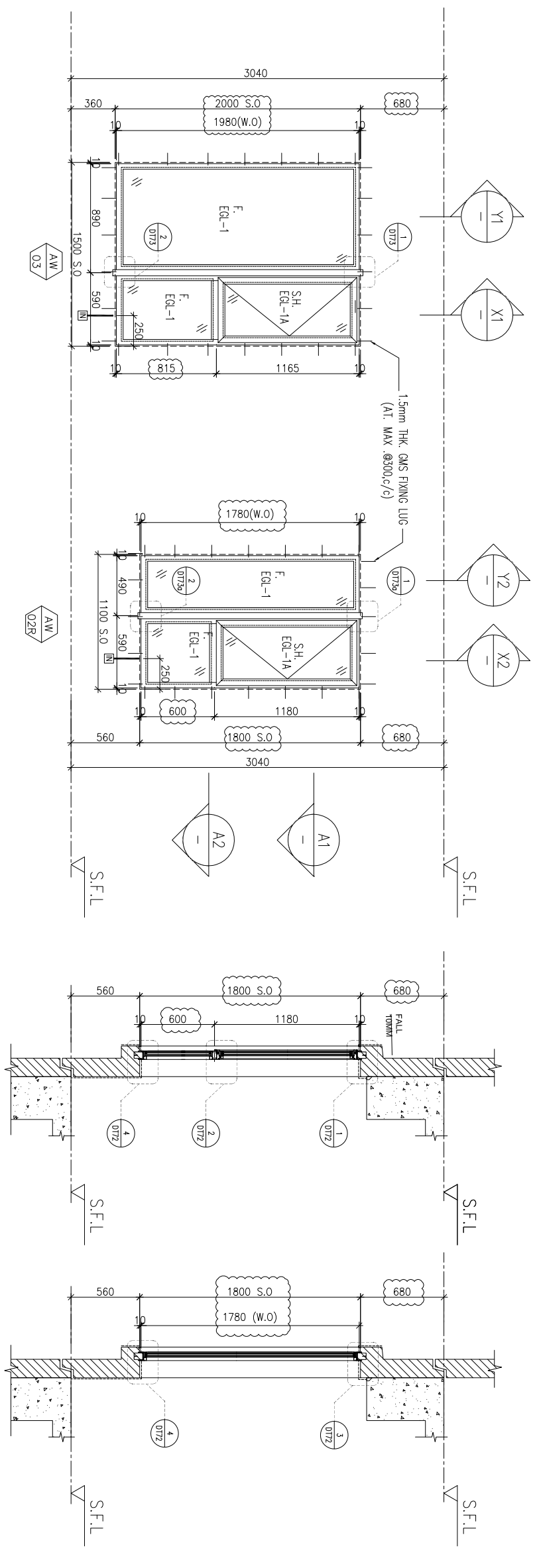

WINDOW MARK	AW 03	AW 02R
LOCATION	3/F-42/F(4/F,13/F,14/F,24/F,34/F OMITTED) UNIT A2	
SECTION	70mm ALUM. SECTION	
GLAZING	EGL-1,EGL-1A	
QUANTITY	35 Nos./35 Nos.	
REMARKS	FAÇADE TYPE T2PF03 FOR 3/F~42/F)	

B.O. REF :

CLIENT :

**SUN HUNG KAI**  
**REAL ESTATE AGENCY LTD.**  
 42/F SUN HUNG KAI CENTRE, WINGLOH, HONGKONG

ARCHITECT :  
**lwk&partners**  
 a r c h i t e c t s

MAIN CONTRACTOR :  
**怡輝建築有限公司**  
**Yee Fai Building Contractors Ltd.**

STRUCTURAL ENGINEER :  
**ARUP**

FAÇADE CONSULTANT:  
**ALPHA CONSULTING LIMITED**  
 Steel Structure & Façade Specialist

NOTE:  
 1. ALL DIMENSIONS ARE IN mm.  
 2. ALL ELEVATIONS ARE VIEWED FROM OUTSIDE.  
 3. ALL DIMENSIONS TO BE VERIFIED ON SITE BEFORE FABRICATION.

LEGEND:

- (X1) — DETAIL MARK NO.
- (X001) — REFER SHEET NO.
- 1. F.F.L. — FINISHED FLOOR LEVEL
- 2. S.F.L. — STRUCTURAL FLOOR LEVEL
- 3. (R) — REVERSED DETAIL
- 4. GLASS LEGEND

EGL-1--8mmHS+12mm AIR GAP+10mmTP THK. I.G.U.  
 EGL-2--10mm THK. CLEAR TEMPERED GLASS  
 EGL-4--10mm THK. TEMPERED ACID ETCHED GLASS  
 EGL-1A--8mmHS+12mm AIR GAP+8mmTP THK. I.G.U.

NO.	DATE	REVISION	SUBJECT TO ARCHITECTMENT
C	29/11/2021	REVISION SUBJECT TO ARCHITECTMENT	None
B	03/11/2021	REVISION SUBJECT TO ARCHITECTMENT	None
A	12/10/2021	REVISION SUBJECT TO ARCHITECTMENT	None

JOB NO. : J-856  
 PROJECT : PROPOSED DEVELOPMENT ABOVE LIGHT RAIL TIN WING STOP-TSWTL NO.23,AREA 33,TIN SHUI WAI, N.T.  
 TITLE : WINDOW SCHEDULE FOR TOWER 2 ALUM. WINDOW

DATE : 02-Aug-21 SCALE : 1:40  
 DRAWN BY : Ivon CHECKED BY :

**美特經貿有限公司**  
**MIDI Aluminium Fabricator Ltd.**  
 Units 6-8, Sunray Industrial Centre, 1/F  
 610 Ona Kwo Ling Road, Kowloon  
 Tel:23489211-4 Fax:(852)27277666  
 DWG NO. : J856-SD-PW-5204 REV. : C

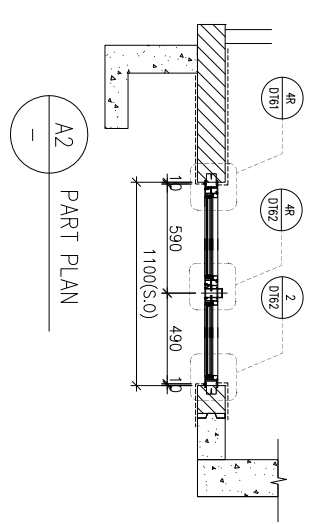
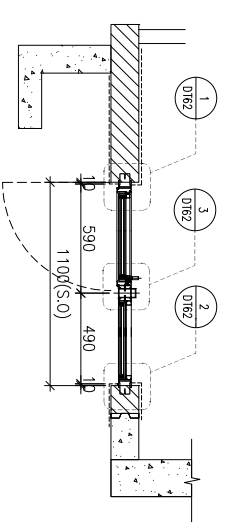
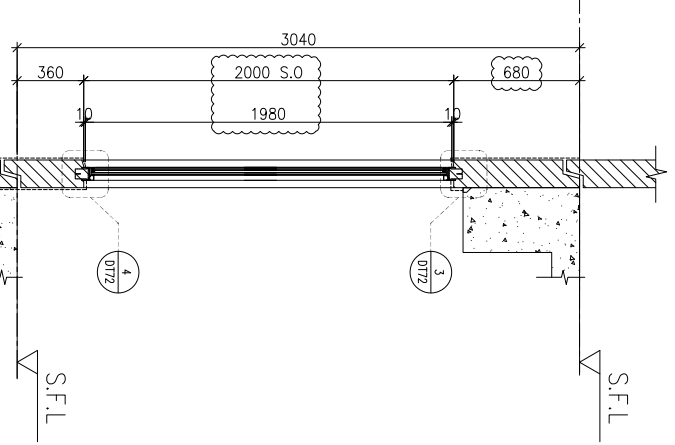
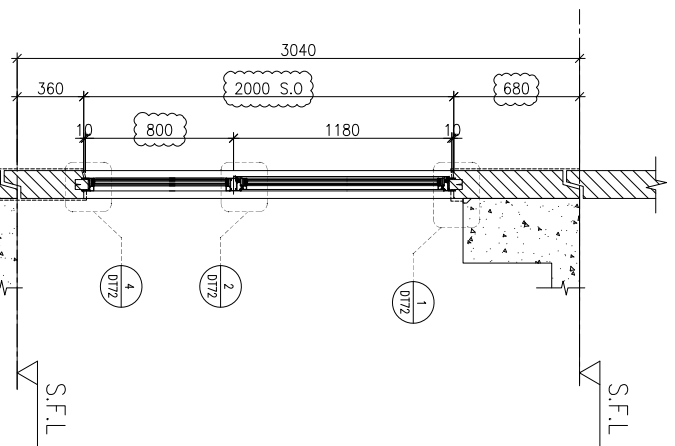
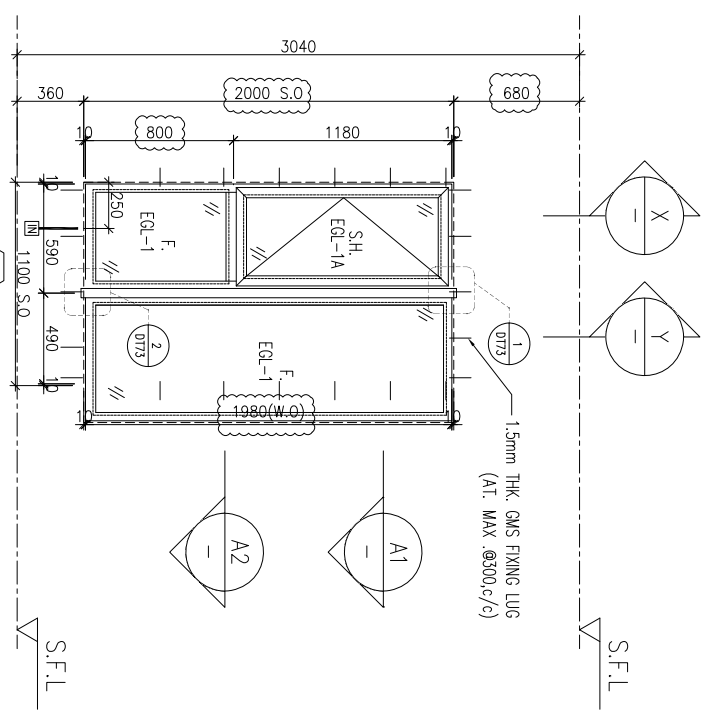

WINDOW MARK	LOCATION	SECTION	GLAZING	QUANTITY	REMARKS
AW 04R	3/F-42/F(4/F,13/F,14/F,24/F,34/F OMITTED) UNIT B7	70mm ALUM. SECTION	EGL-1,EGL-1A	35 Nos	FAÇADE(TYPE T2PF04R FOR 3/F~42/F)
AW 04	3/F-42/F(4/F,13/F,14/F,24/F,34/F OMITTED) UNIT B2,B6,A3,A7	70mm ALUM. SECTION	EGL-1,EGL-1A	35 Nos / 35 Nos / 35 Nos / 35 Nos	FAÇADE(TYPE T1PF04 FOR 3/F~42/F)

B.O. REF :

CLIENT :

**SUN HUNG KAI**  
REAL ESTATE AGENCY LTD.  
42/F SUN HUNG KAI CENTRE, WANGCHAI, HONGKONG

ARCHITECT :

**lwk&partners**  
A R C H I T E C T S

MAIN CONTRACTOR :

**怡輝建築有限公司**  
Yee Fai Building Contractors Ltd.

STRUCTURAL ENGINEER :

**ARUP**

FAÇADE CONSULTANT:

**ALPHA CONSULTING LIMITED**  
Steel Structure & Façade Specialist

NOTE:

1. ALL DIMENSIONS ARE IN mm.
2. ALL ELEVATIONS ARE VIEWED FROM OUTSIDE.
3. ALL DIMENSIONS TO BE VERIFIED ON SITE BEFORE FABRICATION.

LEGEND:

- ⊗11 --- DETAIL MARK NO.
- ⊗001 --- REFER SHEET NO.
- 1. F.F.L. --- FINISHED FLOOR LEVEL
- 2. S.F.L. --- STRUCTURAL FLOOR LEVEL
- 3. ⊗R --- REVERSED DETAIL
- 4. GLASS LEGEND

EGL-1--8mmHS+12mm AIR GAP+10mmTP THK. I.G.U.  
 EGL-2--10mm THK. CLEAR TEMPERED GLASS  
 EGL-4--10mm THK. TEMPERED ACID ETCHED GLASS  
 EGL-1A--8mmHS+12mm AIR GAP+8mmTP THK. I.G.U.

JOB NO. : J-856

PROJECT :  
 PROPOSED DEVELOPMENT ABOVE  
 LIGHT RAIL TIN WING STOP TSWTL  
 NO.23,AREA 33,TIN SHUI WAI, N.T.

TITLE :  
 WINDOW SCHEDULE FOR  
 TOWER 2 ALUM. WINDOW

DATE : 02-Aug-21 SCALE : 1:40

DRAWN BY : Ivon CHECKED BY :

**美特經貿有限公司**  
**MIDI Aluminium Fabricator Ltd.**  
 Units 6-8, Sunray Industrial Centre, 1/F  
 610 Ona Kwo Ling Road, Kowloon  
 Tel:23489211-4 Fax:(852)2727866  
 DWG NO. : J856-SD-PW-5205 REV. : B

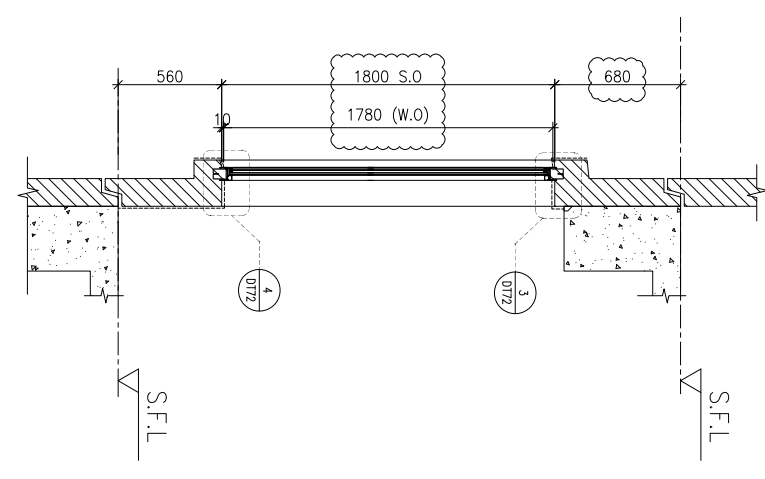
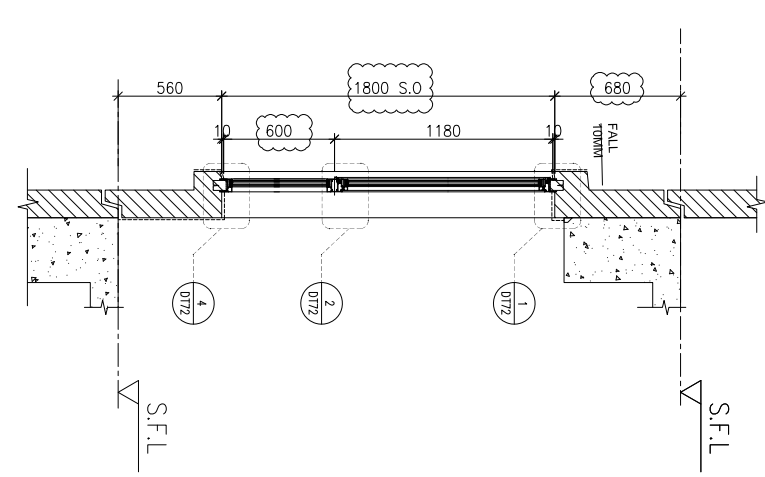
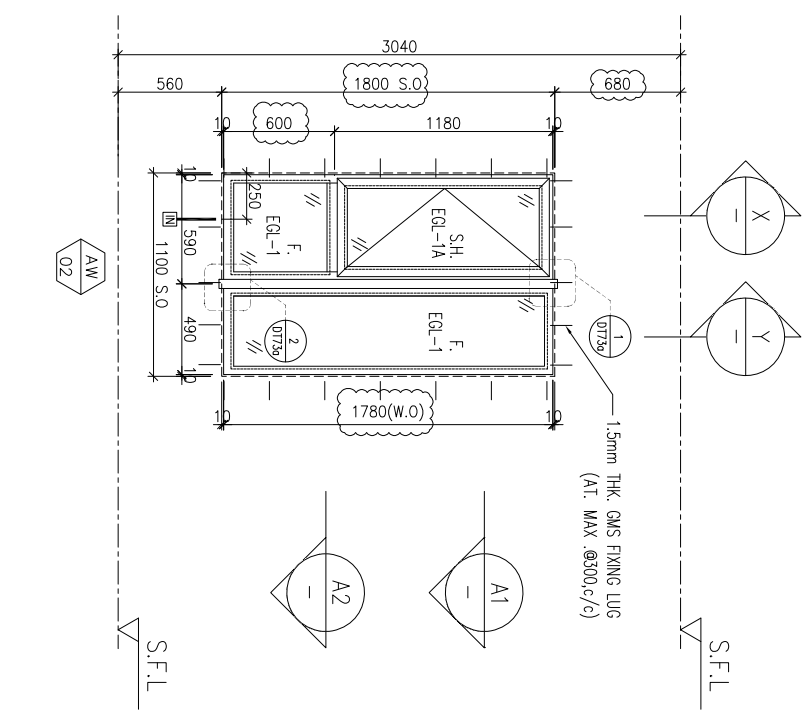

ELEVATION

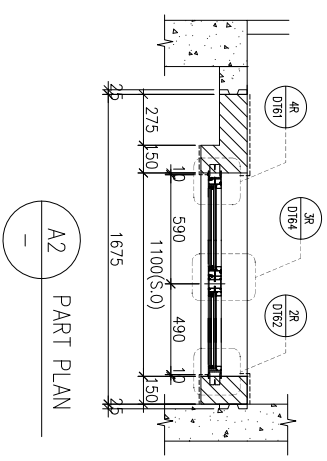
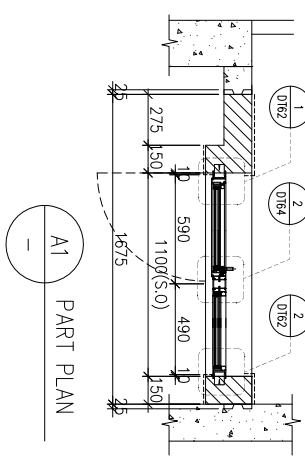

WINDOW MARK	AW 02
LOCATION	3/F-42/F(4/F,13/F,14/F,24/F,34/F OMITTED) UNIT A3,A6,A8,B6,B7
SECTION	70mm ALUM. SECTION
GLAZING	EGL-1,EGL-1A
QUANTITY	35 Nos / 35 Nos / 35 Nos / 35 Nos / 35 Nos
REMARKS	FAÇADE(TYPE T2PF05R FOR 3/F~42/F)

WINDOW MARK	AW 02R
LOCATION	3/F-42/F(4/F,13/F,14/F,24/F,34/F OMITTED) UNIT A7,B2
SECTION	70mm ALUM. SECTION
GLAZING	EGL-1,EGL-1A
QUANTITY	35 Nos / 35 Nos
REMARKS	FAÇADE(TYPE T2PF05 FOR 3/F~42/F)

B.O. REF :

CLIENT :

**SUN HUNG KAI**  
REAL ESTATE AGENCY LTD.  
42/F SUN HUNG KAI CENTRE, WINGHUA, HONGKONG

ARCHITECT :

**Y&P**  
Yee & Partners  
A R C H I T E C T S

MAIN CONTRACTOR :

**Y&C** 怡輝建築有限公司  
Yee Fai Building Contractors Ltd.

STRUCTURAL ENGINEER :

**ARUP**  
ALPHA CONSULTING LIMITED  
Steel Structure & Facade Specialist

FACADE CONSULTANT:

**ARUP**  
ALPHA CONSULTING LIMITED  
Steel Structure & Facade Specialist

NOTE :

1. ALL DIMENSIONS ARE IN mm.
2. ALL ELEVATIONS ARE VIEWED FROM OUTSIDE.
3. ALL DIMENSIONS TO BE VERIFIED ON SITE BEFORE FABRICATION.

LEGEND :

- ①--- DETAIL MARK NO.
- ②--- REFER SHEET NO.
- 1. F.F.L.--FINISHED FLOOR LEVEL
- 2. S.F.L.--STRUCTURAL FLOOR LEVEL
- 3. (R)---REVERSED DETAIL
- 4. GLASS LEGEND

EGL-1--8mmHS+12mm AIR GAP+10mmTP THK. I.G.U.  
 EGL-2--10mm THK. CLEAR TEMPERED GLASS  
 EGL-4--10mm THK. TEMPERED ACID ETCHED GLASS  
 EGL-1A--8mmHS+12mm AIR GAP+8mmTP THK. I.G.U.

NO.	DATE	REVISION	SUBJECT TO ARCH/COMMENT
C	29/11/2021	REVISION SUBJECT TO ARCH/COMMENT	None
B	03/11/2021	REVISION SUBJECT TO ARCH/COMMENT	None
A	12/10/2021	REVISION SUBJECT TO ARCH/COMMENT	None

JOB NO. : J-856

PROJECT :

PROPOSED DEVELOPMENT ABOVE  
LIGHT RAIL TIN WING STOP-TSWTL  
NO.23,AREA 33,TIN SHUI WAI, N.T.

TITLE :

WINDOW SCHEDULE FOR  
TOWER 2 ALUM. WINDOW

DATE : 02-Aug-21 SCALE : 1:40

DRAWN BY : Ivon CHECKED BY :

**MIDI** 美特經貿有限公司  
ALUMINIUM FABRICATOR LTD.  
Units 6-8, Sunray Industrial Centre, 1/F  
610 Ona Kwo Ling Road, Kowloon  
Tel:23489211-4 Fax:(852)27277666  
DWG NO. : J856-SD-PW-5206 REV. : C

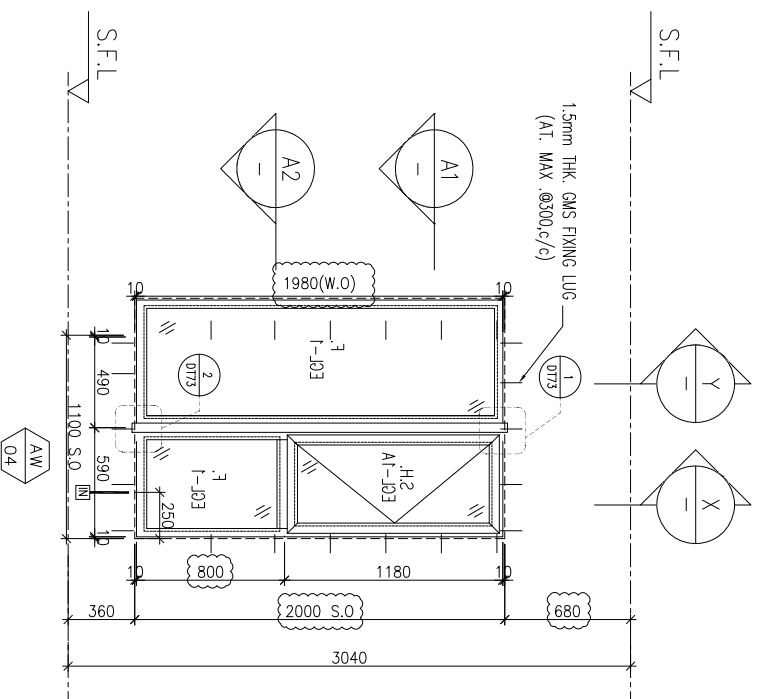

ELEVATION

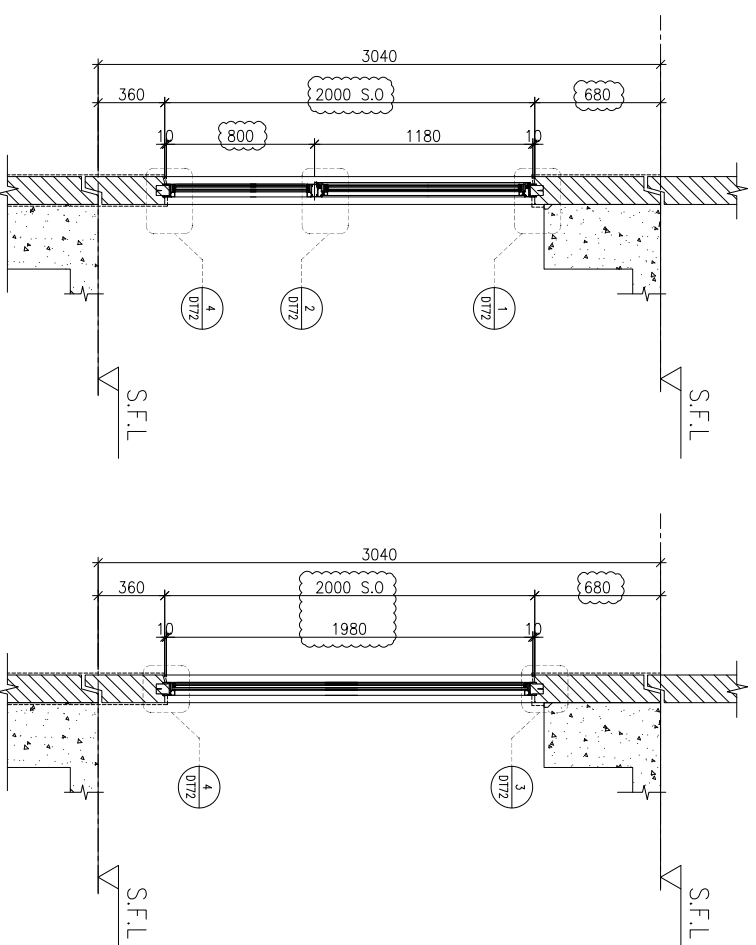

PART SECTION

PART SECTION

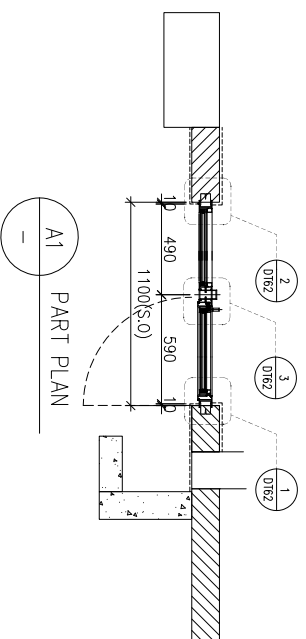

PART PLAN

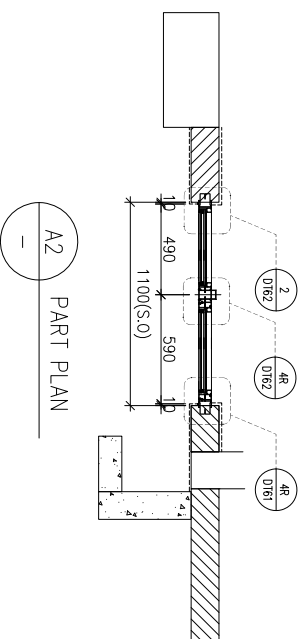

PART PLAN

WINDOW MARK	AW 04
LOCATION	3/F-42/F(4/F,13/F,14/F,24/F,34/F OMITTED) UNIT A5
SECTION	70mm ALUM. SECTION
GLAZING	EGL-1,EGL-1A
QUANTITY	35 Nos
REMARKS	FACADE(TYPE T2PF06R FOR 3/F~42/F)

B.O. REF :

CLIENT :

**SUN HUNG KAI**  
REAL ESTATE AGENCY LTD.

42/F SUN HUNG KAI CENTRE, WINGLOH, HONGKONG

ARCHITECT :

**IWK&partners**  
A R C H I T E C T S

MAIN CONTRACTOR :

**怡輝建築有限公司**  
Yee Fai Building Contractors Ltd.

STRUCTURAL ENGINEER :

**ARUP**

FAÇADE CONSULTANT:

**ALPHA CONSULTING LIMITED**  
Steel Structure & Façade Specialist

NOTE :

1. ALL DIMENSIONS ARE IN mm.
2. ALL ELEVATIONS ARE VIEWED FROM OUTSIDE.
3. ALL DIMENSIONS TO BE VERIFIED ON SITE BEFORE FABRICATION.

LEGEND :

⊗1—DETAIL MARK NO.  
⊗001—REFER SHEET NO.

1. F.F.L.--FINISHED FLOOR LEVEL
2. S.F.L.--STRUCTURAL FLOOR LEVEL
3. ⊗R--REVERSED DETAIL
4. GLASS LEGEND

EGL-1--8mmHS+12mm AIR GAP+10mmTP THK. I.G.U.  
 EGL-2--10mm THK. CLEAR TEMPERED GLASS  
 EGL-4--10mm THK. TEMPERED ACID ETCHED GLASS  
 EGL-1A--8mmHS+12mm AIR GAP+8mmTP THK. I.G.U.

NO.	DATE	REVISION	REVISION SUBJECT TO ARCHITECTMENT	BY
B	29/11/2021		REVISION SUBJECT TO ARCHITECTMENT	WON
A	03/11/2021		REVISION SUBJECT TO ARCHITECTMENT	WON

JOB NO. : J-856

PROJECT :

PROPOSED DEVELOPMENT ABOVE  
LIGHT RAIL TIN WING STOP TSWTL  
NO.23,AREA 33,TIN SHUI WAI, N.T.

TITLE :

WINDOW SCHEDULE FOR  
TOWER 2 ALUM. WINDOW

DATE : 02-Aug-21 SCALE : 1:40

DRAWN BY : WON CHECKED BY :

**美特經貿有限公司**  
MIDI Aluminium Fabricator Ltd.

Units 6-8, Sunray Industrial Centre, 1/F  
610 Ona Kwo Ling Road, Kowloon  
Tel:23489211-4 Fax:(852)2727666

DWG NO. : J856-SD-PW-5207 REV. : B

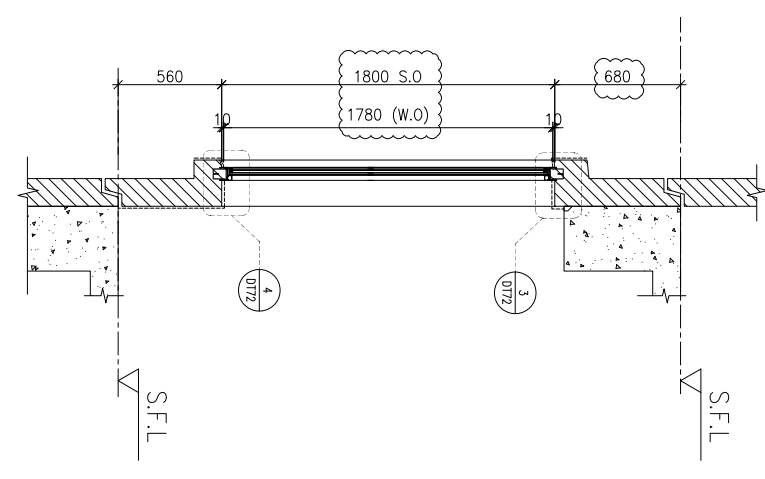
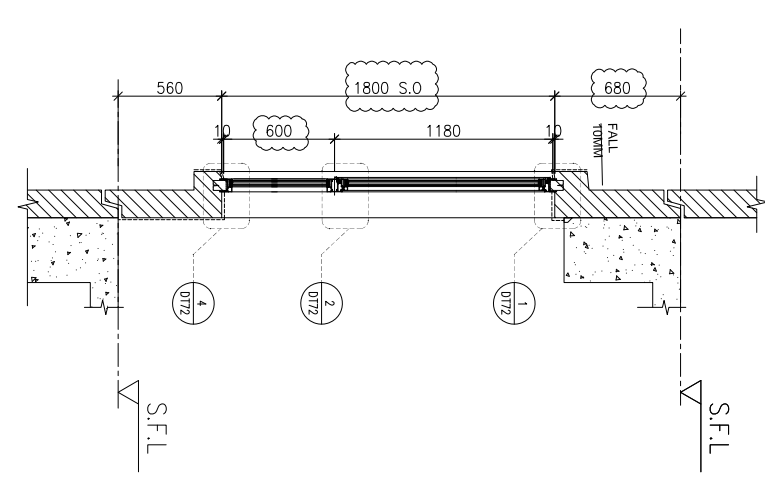
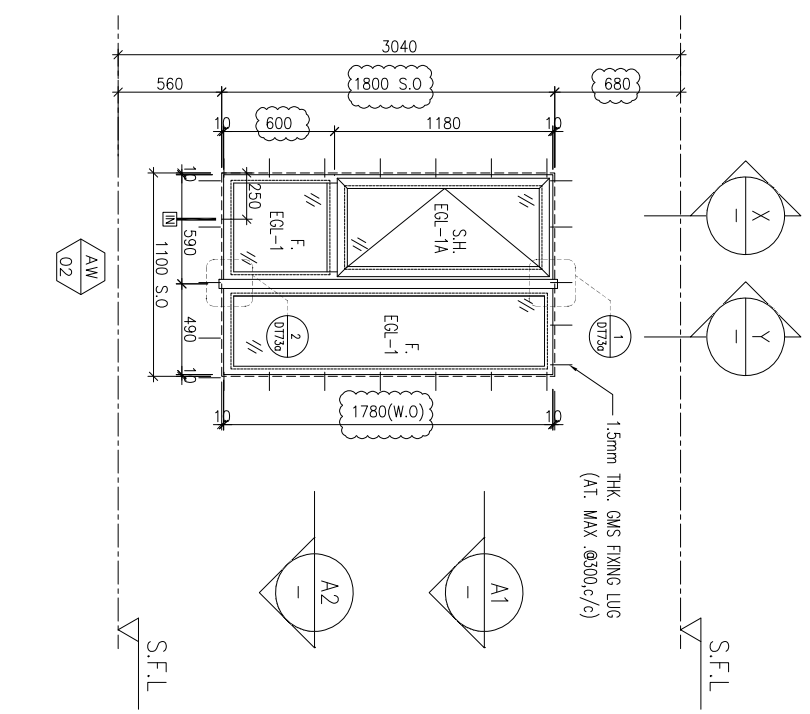

ELEVATION

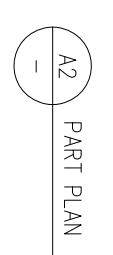
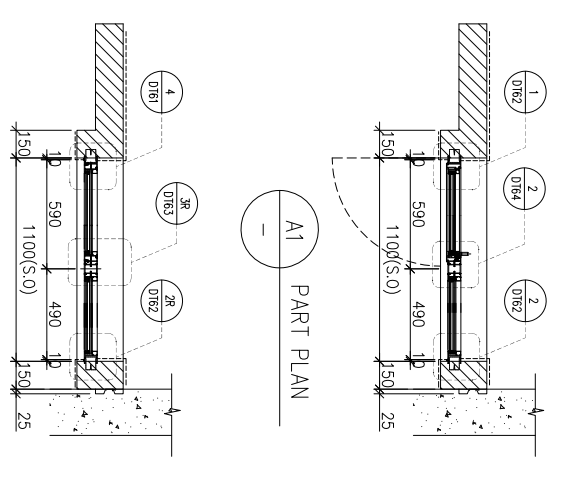

WINDOW MARK	SECTION	LOCATION	QUANTITY	REMARKS
AW 02	70mm ALUM. SECTION	3/F-42/F(4/F,13/F,14/F,24/F,34/F OMITTED) UNIT A8,B1	35 Nos/35 Nos	FAÇADE(TYPE T2PF08R FOR 3/F~42/F)
AW 02R	70mm ALUM. SECTION	3/F-42/F(4/F,13/F,14/F,24/F,34/F OMITTED) UNIT B8	35 Nos	FAÇADE(TYPE T2PF08 FOR 3/F~42/F)

B.O. REF :

CLIENT :

**SUN HUNG KAI**  
**REAL ESTATE AGENCY LTD.**  
42/F SUN HUNG KAI CENTRE, WANGCHAI, HONGKONG

ARCHITECT :

**lwk&partners**  
a r c h i t e c t s

MAIN CONTRACTOR :

**怡輝建築有限公司**  
**Yee Fai Building Contractors Ltd.**

STRUCTURAL ENGINEER :

**ARUP**

FAÇADE CONSULTANT:

**ALPHA CONSULTING LIMITED**  
Steel Structure & Façade Specialist

NOTE :

1. ALL DIMENSIONS ARE IN mm.
2. ALL ELEVATIONS ARE VIEWED FROM OUTSIDE.
3. ALL DIMENSIONS TO BE VERIFIED ON SITE BEFORE FABRICATION.

LEGEND :

**X1** --- DETAIL MARK NO.  
**X001** --- REFER SHEET NO.

1. F.F.L. --- FINISHED FLOOR LEVEL
2. S.F.L. --- STRUCTURAL FLOOR LEVEL
3. **(R)** --- REVERSED DETAIL
4. GLASS LEGEND

EGL-1--8mmHS+12mm AIR GAP+10mmTP THK. I.G.U.  
EGL-2--10mm THK. CLEAR TEMPERED GLASS  
EGL-4--10mm THK. TEMPERED ACID ETCHED GLASS  
EGL-1A--8mmHS+12mm AIR GAP+8mmTP THK. I.G.U.

NO.	DATE	REVISION	SUBJECT TO ARCH/COMMENT	BY
B	29/11/2021		REVISION SUBJECT TO ARCH/COMMENT	lwk
A	03/11/2021		REVISION SUBJECT TO ARCH/COMMENT	lwk

JOB NO. : J-856

PROJECT :

PROPOSED DEVELOPMENT ABOVE  
LIGHT RAIL TIN WING STOP TSWTL  
NO.23,AREA 33,TIN SHUI WAI, N.T.

TITLE :

WINDOW SCHEDULE FOR  
TOWER 2 ALUM. WINDOW

DATE : 02-Aug-21 SCALE : 1:40

DRAWN BY : lwn

CHECKED BY :

**美特經貿有限公司**  
**MIDI Aluminium Fabricator Ltd.**  
Units 6-8, Sunray Industrial Centre, 1/F  
610 Ona Kwo Ling Road, Kowloon  
Tel:23489211-4 Fax:(852)2727866

DWG NO. : J856-SD-PW-5208 REV. : B

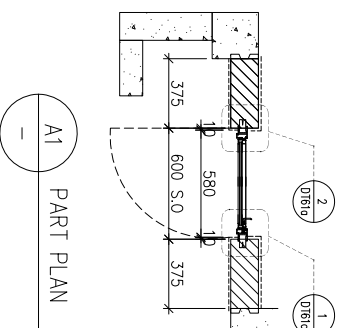
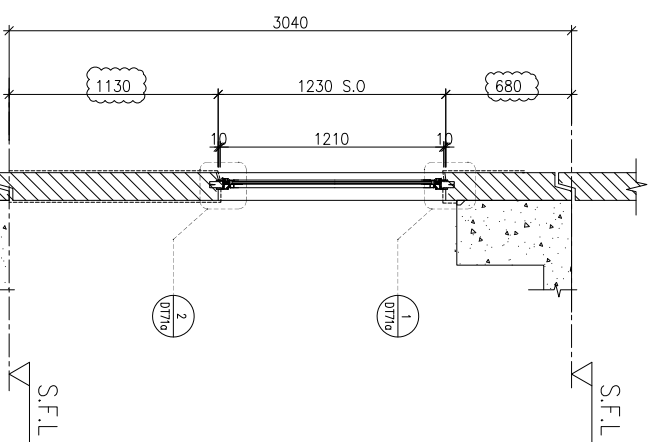
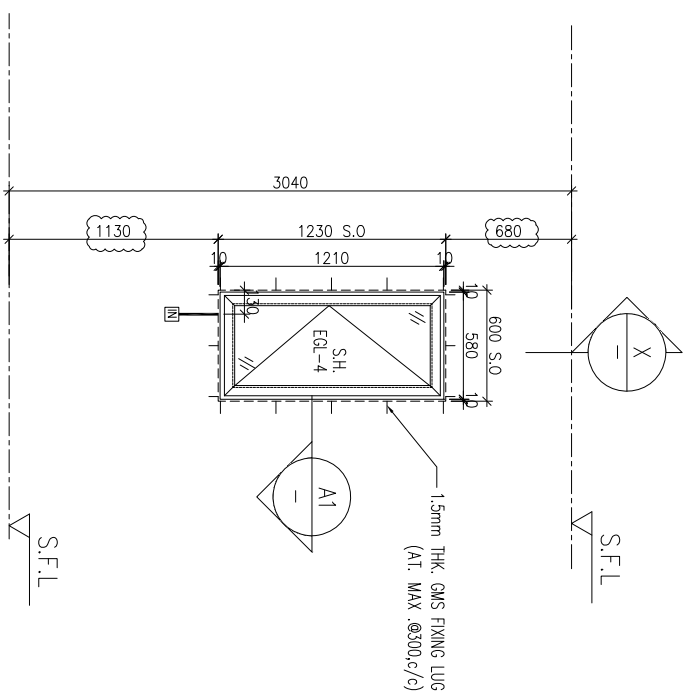

ELEVATION

WINDOW MARK	<b>AW</b> 06
LOCATION	3/F-42/F(4/F,13/F,14/F,24/F,34/F OMITTED) UNIT B3
SECTION	70mm ALUM. SECTION
GLAZING	EGL-4
QUANTITY	35 Nos
REMARKS	FAÇADE(TYPE T2PF09 FOR 3/F~42/F)

B.O. REF :

CLIENT :

**SUN HUNG KAI**  
REAL ESTATE AGENCY LTD.  
42/F SUN HUNG KAI CENTRE, WINGHUA, HONGKONG

ARCHITECT :

**lwk&partners**  
a r c h i t e c t s

MAIN CONTRACTOR :

**怡輝建築有限公司**  
Yee Fai Building Contractors Ltd.

STRUCTURAL ENGINEER :

**ARUP**

FAÇADE CONSULTANT:

**ALPHA CONSULTING LIMITED**  
Steel Structure & Façade Specialist

NOTE :

1. ALL DIMENSIONS ARE IN mm.
2. ALL ELEVATIONS ARE VIEWED FROM OUTSIDE.
3. ALL DIMENSIONS TO BE VERIFIED ON SITE BEFORE FABRICATION.

LEGEND :

- X1** — DETAIL MARK NO.
- X001** — REFER SHEET NO.
- 1. F.F.L. — FINISHED FLOOR LEVEL
- 2. S.F.L. — STRUCTURAL FLOOR LEVEL
- 3. **⊗** — REVERSED DETAIL
- 4. GLASS LEGEND

EGL-1--8mmHS+12mm AIR GAP+10mmTP THK. I.G.U.  
 EGL-2--10mm THK. CLEAR TEMPERED GLASS  
 EGL-4--10mm THK. TEMPERED ACID ETCHED GLASS  
 EGL-1A--8mmHS+12mm AIR GAP+8mmTP THK. I.G.U.

NO.	DATE	REVISION
C	29/11/2021	REVISION SUBJECT TO ARCH/COMMITMENT
B	03/11/2021	REVISION SUBJECT TO ARCH/COMMITMENT
A	12/10/2021	REVISION SUBJECT TO ARCH/COMMITMENT

JOB NO. : J-856

PROJECT :

PROPOSED DEVELOPMENT ABOVE  
LIGHT RAIL TIN WING STOP TSWTL  
NO.23,AREA 33,TIN SHUI WAI, N.T.

TITLE :

WINDOW SCHEDULE FOR  
TOWER 2 ALUM. WINDOW

DATE : 02-Aug-21 SCALE : 1:40

DRAWN BY : Iwon CHECKED BY :

**美特鋁質有限公司**  
MIDI Aluminium Fabricator Ltd.  
Units 6-8, Sunray Industrial Centre, 1/F  
610 Chee Kwo Ling Road, Kowloon  
Tel:23489211-4 Fax:(852)27277666

DWG NO. : J856-SD-PW-5209 REV. : C

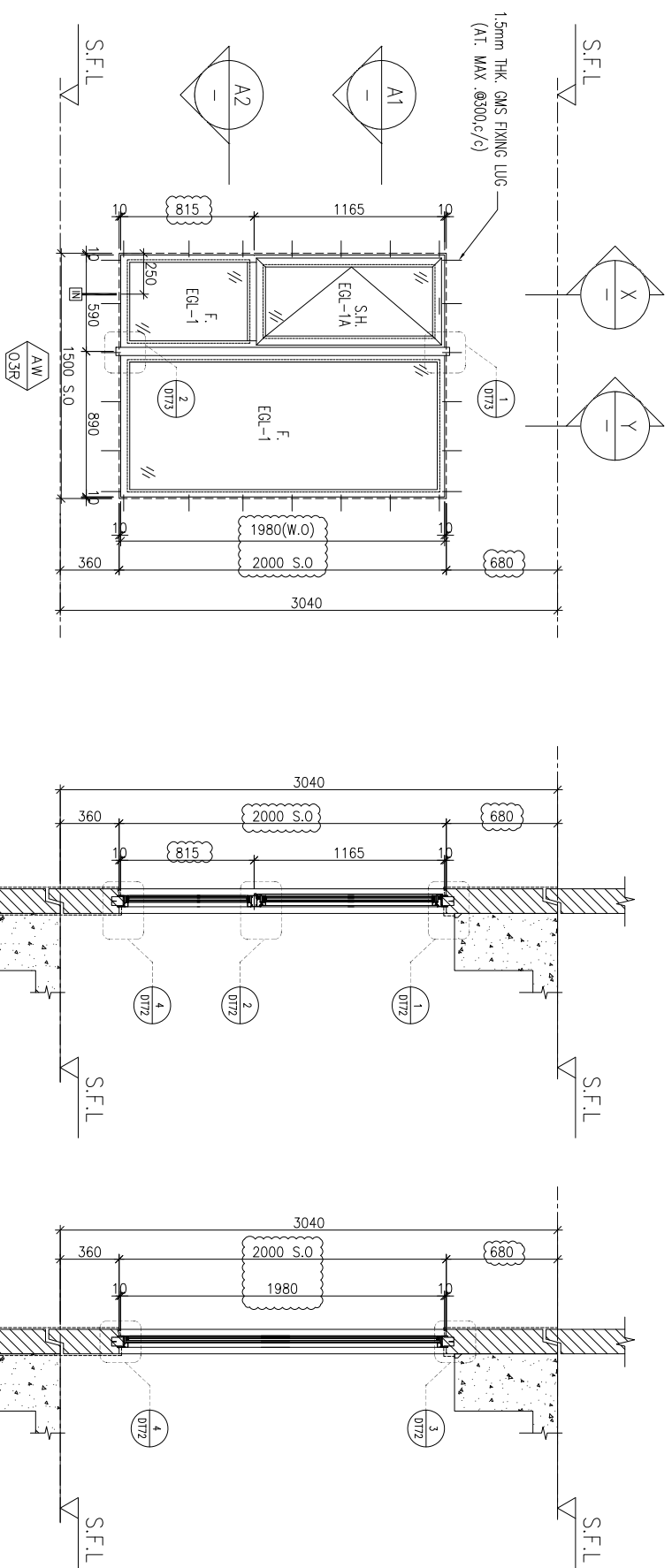

ELEVATION

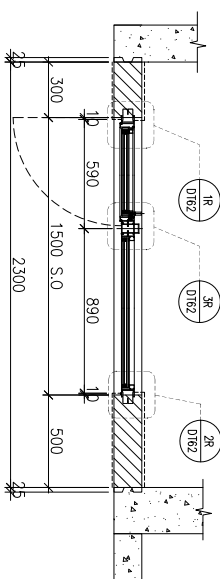

A1 PART PLAN

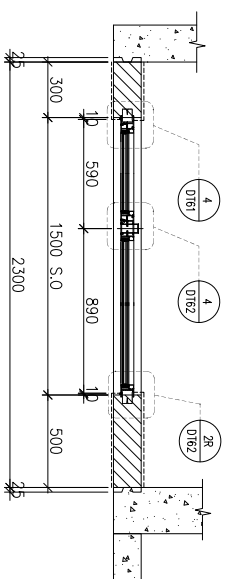

A2 PART PLAN

WINDOW MARK	
LOCATION	3/F-42/F(4/F,13/F,14/F,24/F,34/F OMITTED) UNIT B3
SECTION	70mm ALUM. SECTION
GLAZING	EGL-1,EGL-1A
QUANTITY	35 Nos
REMARKS	FAÇADE(TYPE T1PF10 FOR 3/F~42/F)

B.O. REF :

CLIENT :

**SUN HUNG KAI**  
REAL ESTATE AGENCY LTD.  
42/F SUN HUNG KAI CENTRE, WANGCHAI, HONGKONG

ARCHITECT :

**Iwk&partners**  
A R C H I T E C T S

MAIN CONTRACTOR :

**怡輝建築有限公司**  
Yee Fai Building Contractors Ltd.

STRUCTURAL ENGINEER :

**ARUP**

FAÇADE CONSULTANT:

**ALPHA CONSULTING LIMITED**  
Steel Structure & Façade Specialist

NOTE :

1. ALL DIMENSIONS ARE IN mm.
2. ALL ELEVATIONS ARE VIEWED FROM OUTSIDE.
3. ALL DIMENSIONS TO BE VERIFIED ON SITE BEFORE FABRICATION.

LEGEND :

⊗11 --- DETAIL MARK NO.  
⊗001 --- REFER SHEET NO.

1. F.F.L. -- FINISHED FLOOR LEVEL
2. S.F.L. -- STRUCTURAL FLOOR LEVEL
3. ⊗R --- REVERSED DETAIL
4. GLASS LEGEND

EGL-1--8mmHS+12mm AIR GAP+10mmTP THK. I.G.U.  
 EGL-2--10mm THK. CLEAR TEMPERED GLASS  
 EGL-4--10mm THK. TEMPERED ACID ETCHED GLASS  
 EGL-1A--8mmHS+12mm AIR GAP+8mmTP THK. I.G.U.

NO.	DATE	REVISION	SUBJECT TO AMENDMENT
C	29/11/2021	REVISION SUBJECT TO AMENDMENT	None
B	03/11/2021	REVISION SUBJECT TO AMENDMENT	None
A	12/10/2021	REVISION SUBJECT TO AMENDMENT	None

JOB NO. : J-856

PROJECT :

PROPOSED DEVELOPMENT ABOVE  
LIGHT RAIL TIN WING STOP-TSWTL  
NO.23,AREA 33,TIN SHUI WAI, N.T.

TITLE :

WINDOW SCHEDULE FOR  
TOWER 2 ALUM. WINDOW

DATE : 02-Aug-21 SCALE : 1:40

DRAWN BY : Ivon CHECKED BY :

**美特經貿有限公司**  
MIDI Aluminium Fabricator Ltd.  
Units 6-8, Sunray Industrial Centre, 1/F  
610 Ona Kwo Ling Road, Kowloon  
Tel:23489211-4 Fax:(852)27277666

DWG NO. : J856-SD-PW-5210 REV. : C

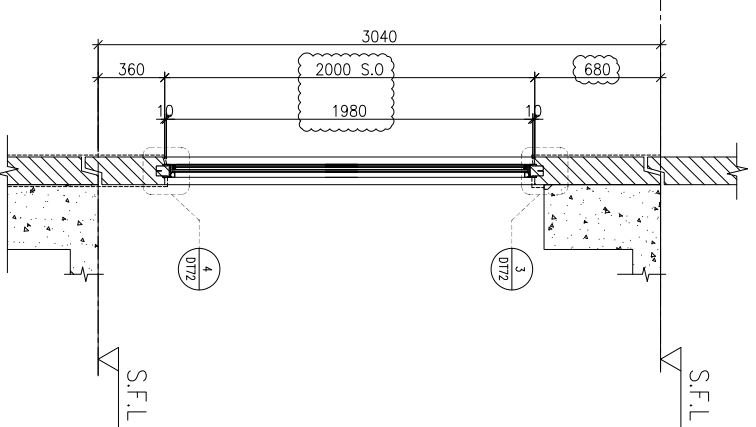
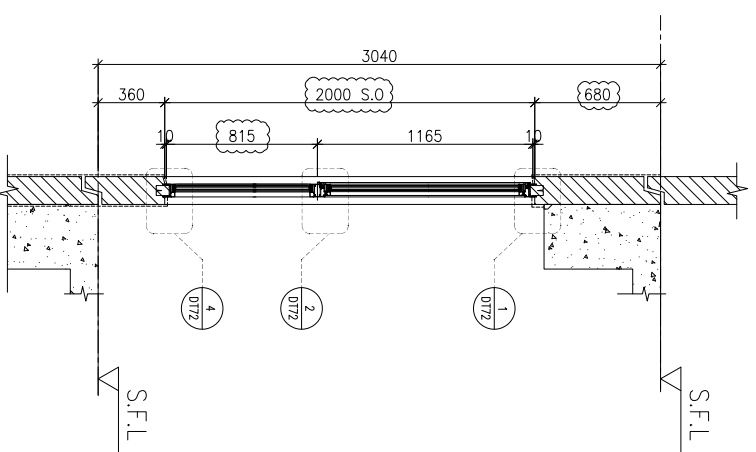
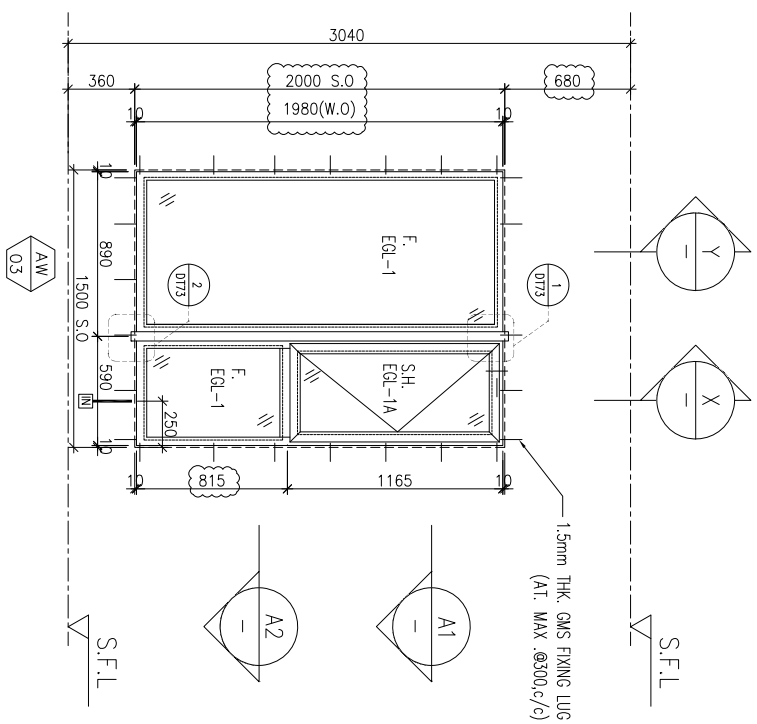

ELEVATION

A1 PART PLAN

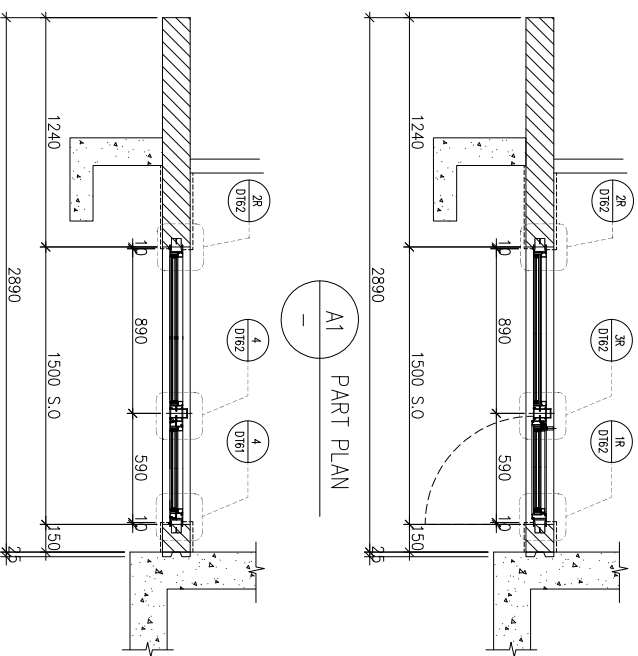

A2 PART PLAN

A2 PART PLAN

WINDOW MARK



LOCATION 3/F-42/F(4/F,13/F,14/F,24/F,34/F OMITTED) UNIT B5

SECTION 70mm ALUM. SECTION

GLAZING EGL-1,EGL-1A

QUANTITY 35 Nos

REMARKS FACADE(TYPE T2PF11R FOR 3/F~42/F)

B.O. REF :

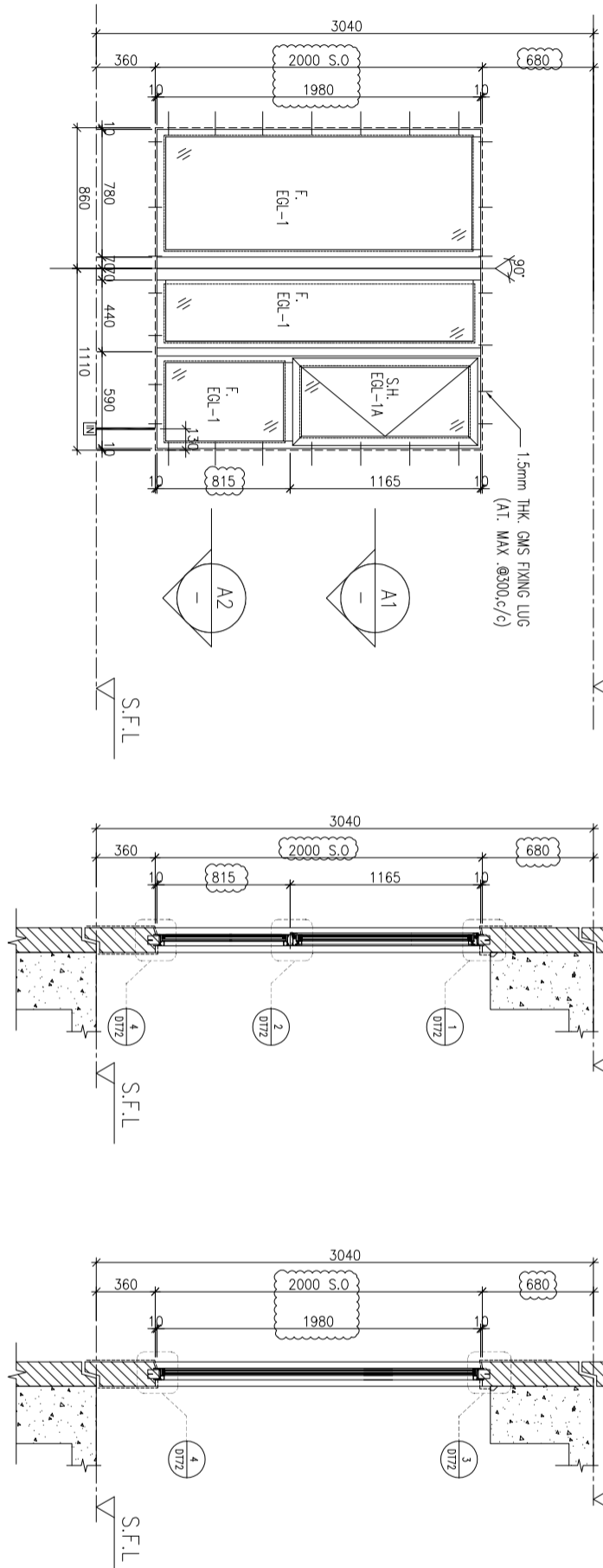
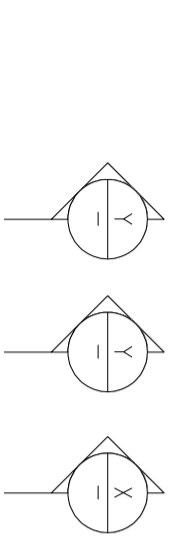

ELEVATION

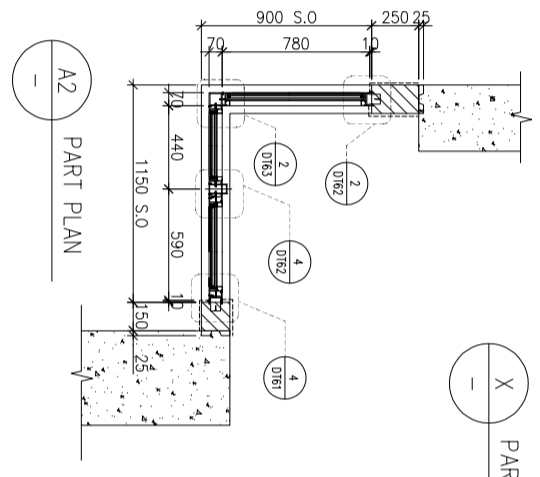
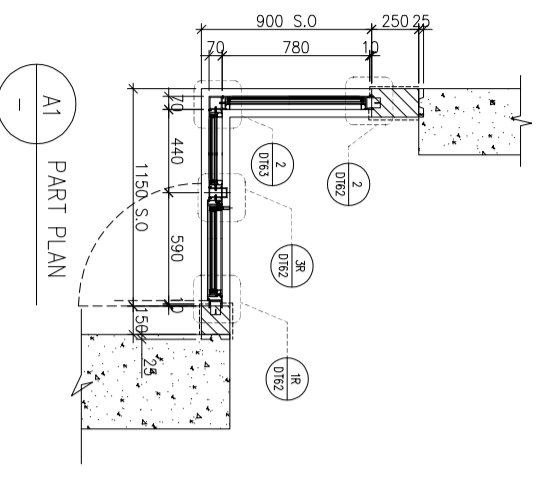

PART SECTION X

PART SECTION Y

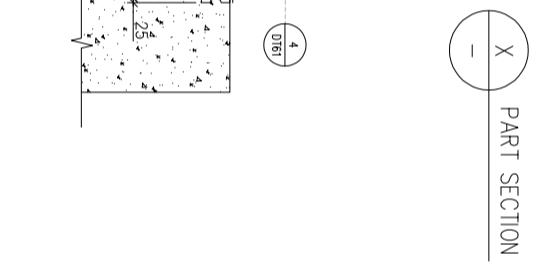

PART PLAN A2

WINDOW MARK

LOCATION 3/F~42/F/4/F.13/F.14/F.24/F.34/F OMITTED) UNIT B8

SECTION 70mm ALUM. SECTION

GLAZING EGL-1,EGL-1A

QUANTITY 35 Nos

REMARKS FACADE(TYPE 12PF13 FOR 3/F~42/F)

B.O. REF :

CLIENT : **SUN HUNG KAI**  
**REAL ESTATE AGENCY LTD.**  
 42/F SUN HUNG KAI CENTRE, WANCHAI, HONGKONG

ARCHITECT : **lwk&partners**  
 a r c h i t e c t s

MAIN CONTRACTOR : **怡輝建築有限公司**  
**Yee Fai Building Contractors Ltd.**

STRUCTURAL ENGINEER : **ARUP**

FAÇADE CONSULTANT: **ALPHA CONSULTING LIMITED**  
 Steel Structure & Façade Specialist

NOTE :  
 1. ALL DIMENSIONS ARE IN mm.  
 2. ALL ELEVATIONS ARE VIEWED FROM OUTSIDE.  
 3. ALL DIMENSIONS TO BE VERIFIED ON SITE BEFORE FABRICATION.

LEGEND :  
 X1 --- DETAIL MARK NO.  
 X001 --- REFER SHEET NO.

1. F.F.L.--FINISHED FLOOR LEVEL  
 2. S.F.L.--STRUCTURAL FLOOR LEVEL  
 3. (R) --REVERSED DETAIL  
 4. GLASS LEGEND

EGL-1--8mmHS+12mm AIR GAP+10mmTP THK. I.G.U.  
 EGL-2--10mm THK. CLEAR TEMPERED GLASS  
 EGL-4--10mm THK. TEMPERED ACID ETCHED GLASS  
 EGL-1A-8mmHS+12mm AIR GAP+8mmTP THK. I.G.U.

NO.	DATE	REVISION
C	29/11/2021	REVISION SUBJECT TO ARCH.COMMENT
B	03/11/2021	REVISION SUBJECT TO ARCH.COMMENT
A	12/10/2021	REVISION SUBJECT TO ARCH.COMMENT

JOB NO. : J-856

PROJECT : PROPOSED DEVELOPMENT ABOVE LIGHT RAIL TIN WING STOP TSWTL NO.23,AREA 33,TIN SHUI WAI, N.T.

TITLE : WINDOW SCHEDULE FOR TOWER 2 ALUM. WINDOW

DATE : 02-Aug-21 SCALE : 1:40

DRAWN BY : IvoM CHECKED BY :

**美特鋁質有限公司**  
**MIDI ALUMINIUM FABRICATOR LTD.**  
 Units 6-8, Sunny Industrial Centre, 1/F  
 610 Che Kwo Ling Road, Kowloon  
 Tel:23489211-4 Fax:85227272666  
 DWG NO. : 856-SD-PW-5211 REV. : C

B.O. REF :

CLIENT :

**SUN HUNG KAI**  
REAL ESTATE AGENCY LTD.

42/F SUN HUNG KAI CENTRE, WANGCHAI, HONGKONG

ARCHITECT :

**Iwk&partners**  
A R C H I T E C T S

MAIN CONTRACTOR :

**怡輝建築有限公司**  
Yee Fai Building Contractors Ltd.

STRUCTURAL ENGINEER :

**ARUP**

FAÇADE CONSULTANT:

**ALPHA CONSULTING LIMITED**  
Steel Structure & Façade Specialist

NOTE :

1. ALL DIMENSIONS ARE IN mm.
2. ALL ELEVATIONS ARE VIEWED FROM OUTSIDE.
3. ALL DIMENSIONS TO BE VERIFIED ON SITE BEFORE FABRICATION.

LEGEND :

- X1** — DETAIL MARK NO.
- X001** — REFER SHEET NO.
- 1. F.F.L. — FINISHED FLOOR LEVEL
- 2. S.F.L. — STRUCTURAL FLOOR LEVEL
- 3. **↺** — REVERSED DETAIL
- 4. GLASS LEGEND

EGL-1--8mmHS+12mm AIR GAP+10mmTP THK. I.G.U.  
EGL-2--10mm THK. CLEAR TEMPERED GLASS  
EGL-4--10mm THK. TEMPERED ACID ETCHED GLASS  
EGL-1A--8mmHS+12mm AIR GAP+8mmTP THK. I.G.U.

NO.	DATE	REVISION
D	29/11/2021	REVISION SUBJECT TO ARCHITECTMENT
C	02/11/2021	REVISION SUBJECT TO ARCHITECTMENT
B	28/10/2021	REVISION SUBJECT TO ARCHITECTMENT
A	18/10/2021	REVISION SUBJECT TO ARCHITECTMENT

JOB NO. : J-856

PROJECT :

PROPOSED DEVELOPMENT ABOVE  
LIGHT RAIL TIN WING STOP TSWTL  
NO.23,AREA 33,TIN SHUI WAI, N.T.

TITLE :

WINDOW SCHEDULE FOR  
TOWER 3 ALUM. WINDOW

DATE : 02-Aug-21 SCALE : 1:40

DRAWN BY : von CHECKED BY :

**美特經貿有限公司**  
MIDI Aluminium Fabricator Ltd.

Units 6-8, Sunray Industrial Centre, 1/F  
610 Ona Kwo Ling Road, Kowloon  
Tel:23489211-4 Fax:(852)2727666

DWG NO. : J856-SD-PW-5301 REV. : D

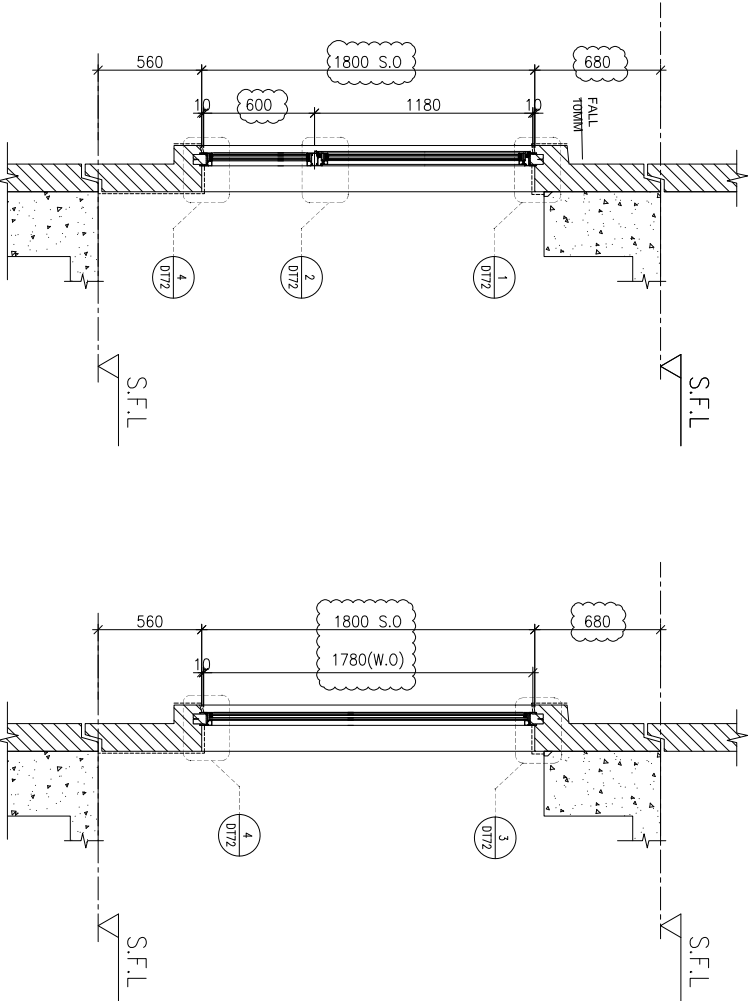
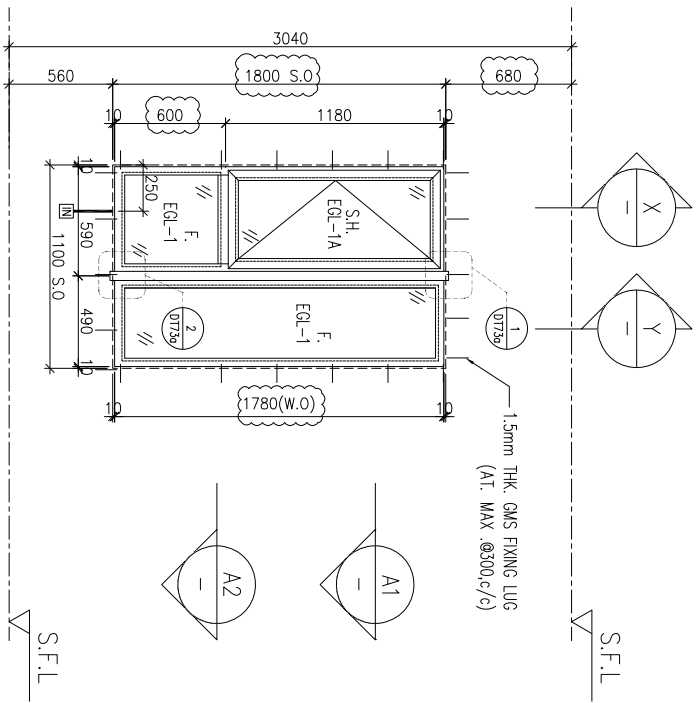

ELEVATION

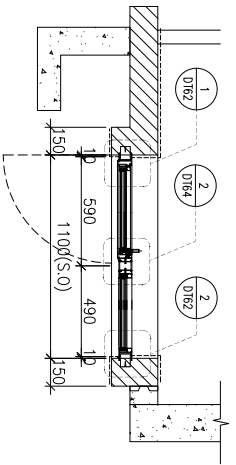

A1 PART PLAN

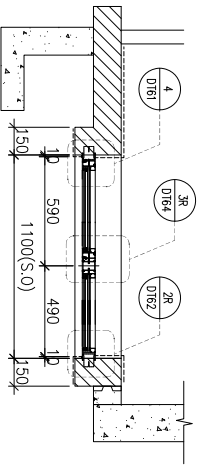

A2 PART PLAN

WINDOW MARK	LOCATION	SECTION	QUANTITY	REMARKS
AW 02	3/F-42/F(4/F,13/F,14/F,24/F,34/F OMITTED) UNIT B6	70mm ALUM. SECTION	35 Nos.	FAÇADE(TYPE T3PF02 FOR 3/F~42/F)
AW 02R	3/F-42/F(4/F,13/F,14/F,24/F,34/F OMITTED) UNIT A9,B7,B8	70mm ALUM. SECTION	35 Nos / 35 Nos / 35 Nos	FAÇADE(TYPE T3PF02R FOR 3/F~42/F)

B.O. REF :

CLIENT :

**SUN HUNG KAI**  
**REAL ESTATE AGENCY LTD.**  
 42/F SUN HUNG KAI CENTRE, WINGHUA, HONGKONG

ARCHITECT :  
**lwk&partners**  
 a r c h i t e c t s

MAIN CONTRACTOR :  
**怡輝建築有限公司**  
**Yee Fai Building Contractors Ltd.**

STRUCTURAL ENGINEER :

**ARUP**

FAÇADE CONSULTANT:  
**ALPHA CONSULTING LIMITED**  
 Steel Structure & Façade Specialist

NOTE:  
 1. ALL DIMENSIONS ARE IN mm.  
 2. ALL ELEVATIONS ARE VIEWED FROM OUTSIDE.  
 3. ALL DIMENSIONS TO BE VERIFIED ON SITE BEFORE FABRICATION.

LEGEND:

- DETAIL MARK NO.
- REFER SHEET NO.
- 1. F.F.L.--FINISHED FLOOR LEVEL
- 2. S.F.L.--STRUCTURAL FLOOR LEVEL
- 3. --REVERSED DETAIL
- 4. GLASS LEGEND

EGL-1--8mmHS+12mm AIR GAP+10mmTP THK. I.G.U.  
 EGL-2--10mm THK. CLEAR TEMPERED GLASS  
 EGL-4--10mm THK. TEMPERED ACID ETCHED GLASS  
 EGL-1A--8mmHS+12mm AIR GAP+8mmTP THK. I.G.U.

NO.	DATE	REVISION	REVISION SUBJECT TO ARCHITECTMENT
E	29/11/2021		REVISION SUBJECT TO ARCHITECTMENT
D	02/11/2021		REVISION SUBJECT TO ARCHITECTMENT
C	26/10/2021		REVISION SUBJECT TO ARCHITECTMENT
B	18/10/2021		REVISION SUBJECT TO ARCHITECTMENT
A	27/09/2021		REVISION SUBJECT TO ARCHITECTMENT

JOB NO. : J-856

PROJECT :  
 PROPOSED DEVELOPMENT ABOVE  
 LIGHT RAIL TIN WING STOP-TSWTL  
 NO.23,AREA 33,TIN SHUI WAI, N.T.

TITLE :  
 WINDOW SCHEDULE FOR  
 TOWER 3 ALUM. WINDOW

DATE : 02-Aug-21 SCALE : 1:40

DRAWN BY : Ivon CHECKED BY :

**美特鋁業有限公司**  
**MIDI ALUMINIUM FABRICATOR LTD.**  
 Units 6-8, Sunray Industrial Centre, 1/F  
 610 Ona Kwo Ling Road, Kowloon  
 Tel:23489211-4 Fax:(852)27277666  
 DWG NO. : J856-SD-PW-5302 REV. : E

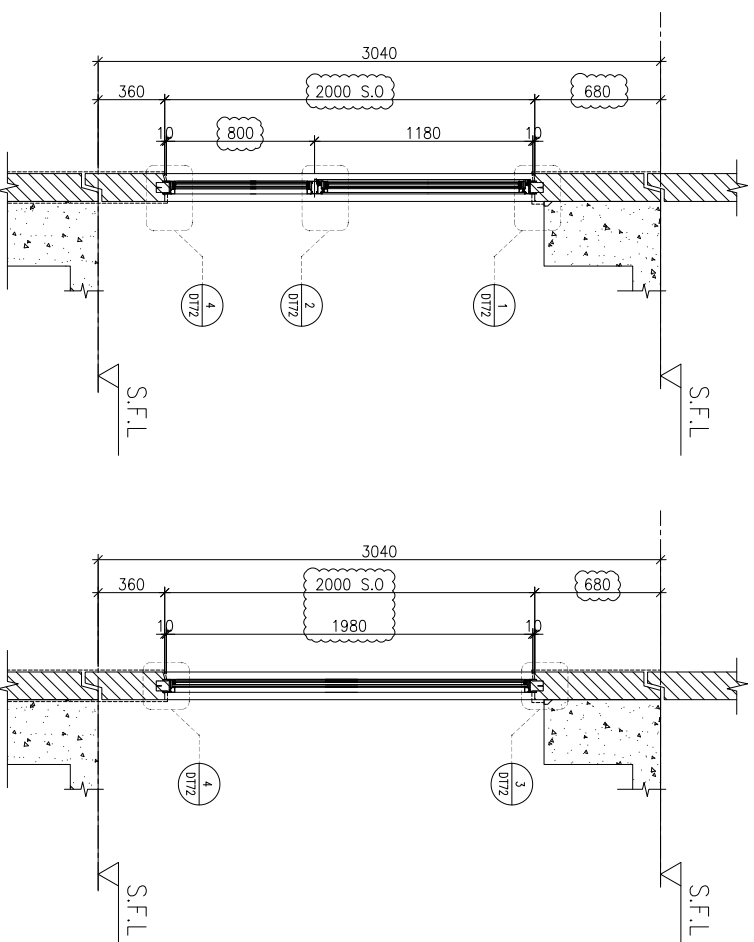
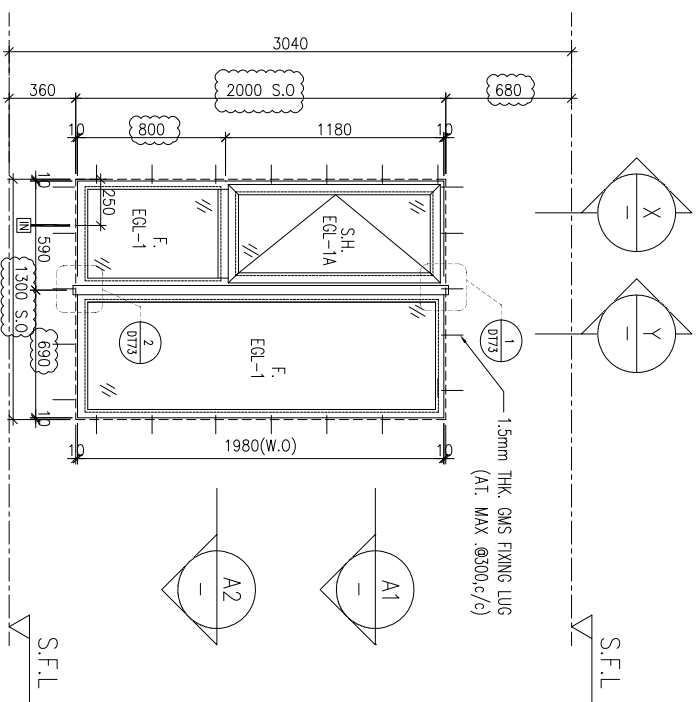

ELEVATION

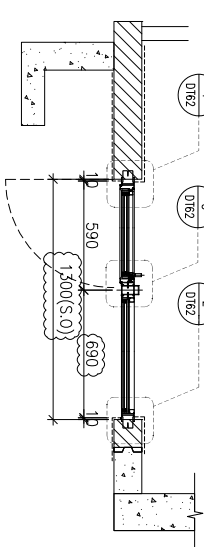

PART PLAN

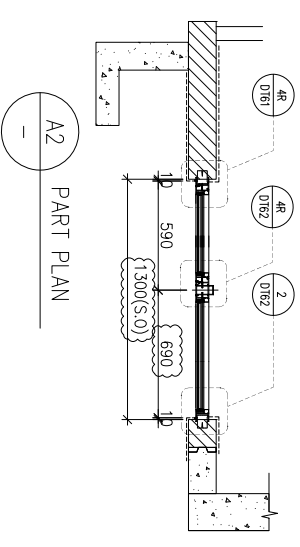

PART PLAN

WINDOW MARK	UNIT
	A3,A6,A10,B5

WINDOW MARK	UNIT
	A13,B11

LOCATION	SECTION
3/F-42/F(4/F,13/F,14/F,24/F,34/F OMITTED)	70mm ALUM. SECTION

LOCATION	SECTION
3/F-42/F(4/F,13/F,14/F,24/F,34/F OMITTED)	70mm ALUM. SECTION

GLAZING	QUANTITY
EGL-1,EGL-1A	35 Nos / 35 Nos / 35 Nos / 35 Nos

GLAZING	QUANTITY
EGL-1,EGL-1A	35 Nos / 35 Nos

REMARKS
FAÇADE(TYPE T3PF04 FOR 3/F~42/F)

REMARKS
FAÇADE(TYPE T3PF04R FOR 3/F~42/F)

BD. REF :

CLIENT :

**SUN HUNG KAI**  
REAL ESTATE AGENCY LTD.  
42/F SUN HUNG KAI CENTRE, WANGCHAI, HONGKONG

ARCHITECT :

**Iwk&partners**  
a r c h i t e c t s

MAIN CONTRACTOR :

**怡輝建築有限公司**  
Yee Fai Building Contractors Ltd.

STRUCTURAL ENGINEER :

**ARUP**

FAÇADE CONSULTANT:

**ALPHA CONSULTING LIMITED**  
Steel Structure & Façade Specialist

ELEVATION

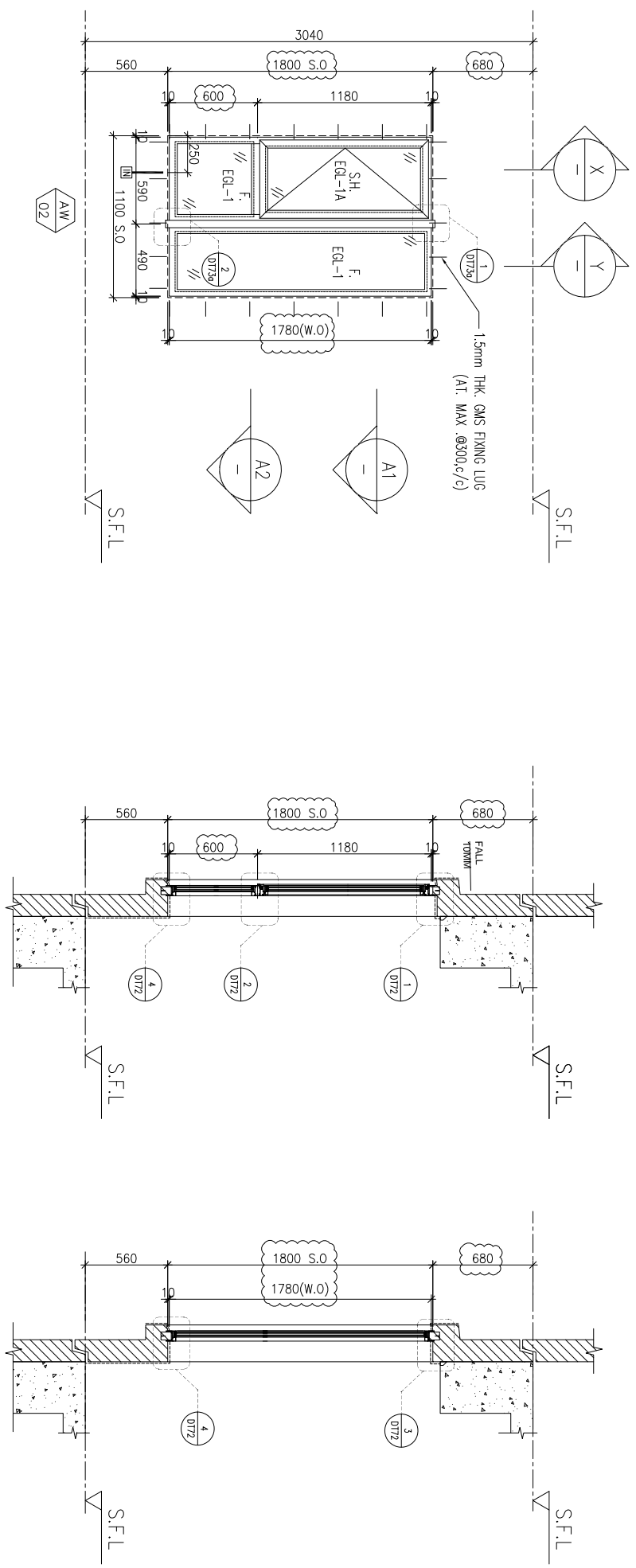

X PART SECTION

Y PART SECTION

A1 PART PLAN

A2 PART PLAN

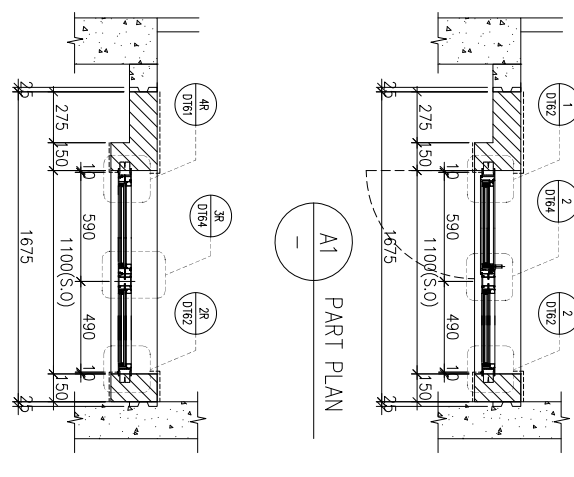

WINDOW MARK	AW 02	AW 02B
LOCATION	3/F~42/F(4/F,13/F,14/F,24/F,34/F OMITTED) UNIT A2,A10,A11,B3,B5,B9	
SECTION	70mm ALUM. SECTION	
GLAZING	EGL-1,EGL-1A	
QUANTITY	35 Nos / 35 Nos / 35 Nos / 35 Nos / 35 Nos / 35 Nos	
REMARKS	FAÇADE(TYPE T3PF05R FOR 3/F~42/F)	

TITLE :	WINDOW SCHEDULE FOR TOWER 3 ALUM. WINDOW		
DATE :	02-Aug-21		
SCALE :	1:40		
DRAWN BY :	ivan		
CHECKED BY :			
JOB NO. :	J-856		
PROJECT :	PROPOSED DEVELOPMENT ABOVE LIGHT RAIL TIN WING STOP TSWTL NO.23,AREA 33,TIN SHUI WAI, N.T.		
NO.	DATE	REVISION	REVISION SUBJECT TO APPROVAL/COMMENT
E	29/11/2021		REVISION SUBJECT TO APPROVAL/COMMENT
D	02/11/2021		REVISION SUBJECT TO APPROVAL/COMMENT
C	28/10/2021		REVISION SUBJECT TO APPROVAL/COMMENT
B	18/10/2021		REVISION SUBJECT TO APPROVAL/COMMENT
A	27/09/2021		REVISION SUBJECT TO APPROVAL/COMMENT

NOTE:

1. ALL DIMENSIONS ARE IN mm.
2. ALL ELEVATIONS ARE VIEWED FROM OUTSIDE.
3. ALL DIMENSIONS TO BE VERIFIED ON SITE BEFORE FABRICATION.

LEGEND:

X1 --- DETAIL MARK NO.  
X001 --- REFER SHEET NO.

1. F.F.L. --- FINISHED FLOOR LEVEL.
2. S.F.L. --- STRUCTURAL FLOOR LEVEL.
3. (R) --- REVERSED DETAIL.

4. GLASS LEGEND

EGL-1 --- 6mmHS+12mm AIR GAP+10mmTP THK. I.G.U.  
EGL-2 --- 10mm THK. CLEAR TEMPERED GLASS  
EGL-4 --- 10mm THK. TEMPERED ACID ETCHED GLASS  
EGL-1A --- 6mmHS+12mm AIR GAP+8mmTP THK. I.G.U.

**美特鋁質有限公司**  
MIDI ALUMINIUM FABRICATOR LTD.  
Units 6-8, Sunray Industrial Centre, 1/F  
610 Cha Kwo Ling Road, Kowloon  
Tel:23489211-4 Fax:(852)27277666  
DWG NO. : J856-S0-PW-5303 REV. : E

B.O. REF :

CLIENT :

**SUN HUNG KAI**  
REAL ESTATE AGENCY LTD.  
42/F SUN HUNG KAI CENTRE, WINGLOH, HONGKONG

ARCHITECT :

**IWK&partners**  
A R C H I T E C T S

MAIN CONTRACTOR :

**怡輝建築有限公司**  
**Yee Fai** Building Contractors Ltd.

STRUCTURAL ENGINEER :

**ARUP**

FAÇADE CONSULTANT:

**ALPHA CONSULTING LIMITED**  
Steel Structure & Façade Specialist

NOTE:

1. ALL DIMENSIONS ARE IN mm.
2. ALL ELEVATIONS ARE VIEWED FROM OUTSIDE.
3. ALL DIMENSIONS TO BE VERIFIED ON SITE BEFORE FABRICATION.

LEGEND:

- X1** — DETAIL MARK NO.
- X001** — REFER SHEET NO.
- 1. F.F.L. — FINISHED FLOOR LEVEL
- 2. S.F.L. — STRUCTURAL FLOOR LEVEL
- 3. **(R)** — REVERSED DETAIL
- 4. GLASS LEGEND

EGL-1—8mmHS+12mm AIR GAP+10mmTP THK. I.G.U.  
EGL-2—10mm THK. CLEAR TEMPERED GLASS  
EGL-4—10mm THK. TEMPERED ACID ETCHED GLASS  
EGL-1A—8mmHS+12mm AIR GAP+8mmTP THK. I.G.U.

NO.	DATE	REVISION	REVISION SUBJECT TO ARCH/COMPONENT
E	29/11/2021		REVISION SUBJECT TO ARCH/COMPONENT
D	02/11/2021		REVISION SUBJECT TO ARCH/COMPONENT
C	26/10/2021		REVISION SUBJECT TO ARCH/COMPONENT
B	18/10/2021		REVISION SUBJECT TO ARCH/COMPONENT
A	27/09/2021		REVISION SUBJECT TO ARCH/COMPONENT

JOB NO. : J-856

PROJECT :

PROPOSED DEVELOPMENT ABOVE  
LIGHT RAIL TIN WING STOP TSWTL  
NO.23,AREA 33,TIN SHUI WAI, N.T.

TITLE :

WINDOW SCHEDULE FOR  
TOWER 3 ALUM. WINDOW

DATE : 02-Aug-21 SCALE : 1:40

DRAWN BY : Ivon CHECKED BY :

**美特鋁業有限公司**  
**MIDI ALUMINIUM FABRICATOR LTD.**  
Units 6-8, Sunray Industrial Centre, 1/F  
610 Ona Kwo Ling Road, Kowloon  
Tel:23489211-4 Fax:(852)2727666

DWG NO. : J856-SD-PW-5304 REV. : E

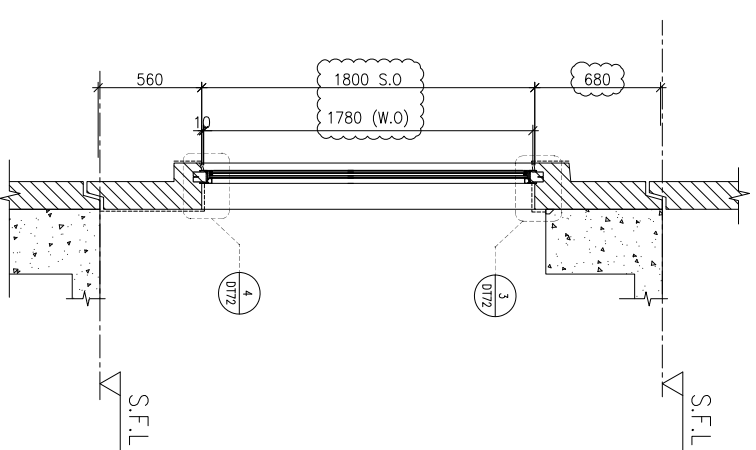
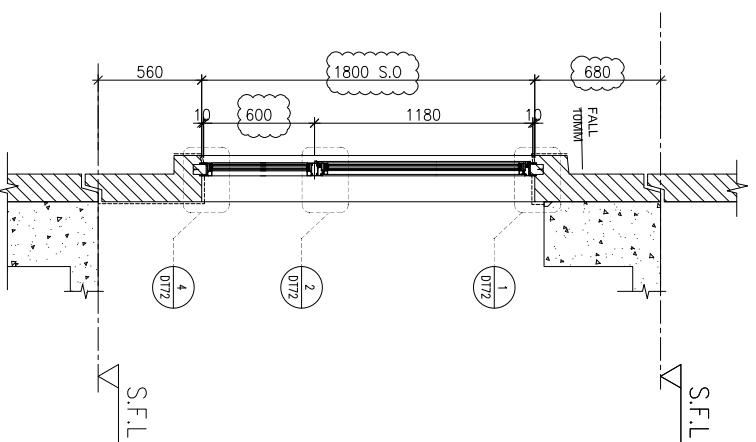
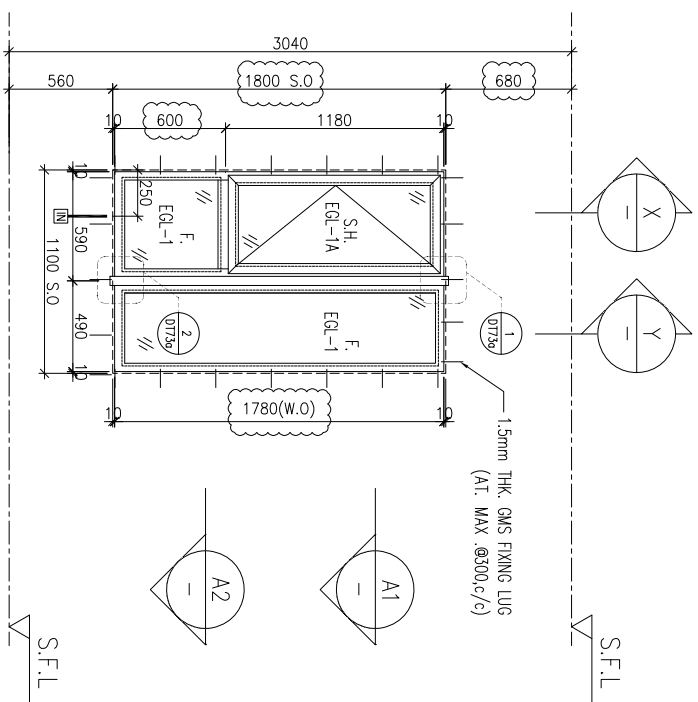

ELEVATION

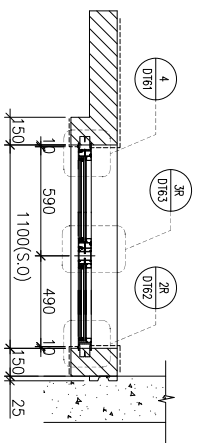
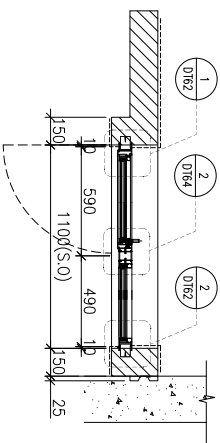

WINDOW MARK	<b>AW</b> 02
LOCATION	3/F-42/F(4/F,13/F,14/F,24/F,34/F OMITTED) UNIT B3
SECTION	70mm ALUM. SECTION
GLAZING	EGL-1,EGL-1A
QUANTITY	35 Nos
REMARKS	FAÇADE(TYPE T3PF08R FOR 3/F~42/F)

WINDOW MARK	<b>AW</b> 02R
LOCATION	3/F-42/F(4/F,13/F,14/F,24/F,34/F OMITTED) UNIT A2,A5,B1
SECTION	70mm ALUM. SECTION
GLAZING	EGL-1,EGL-1A
QUANTITY	35 Nos / 35 Nos / 35 Nos
REMARKS	FAÇADE(TYPE T3PF08R FOR 3/F~42/F)

B.O. REF :

CLIENT :

**SUN HUNG KAI**  
REAL ESTATE AGENCY LTD.  
42/F SUN HUNG KAI CENTRE, WANGCHAI, HONGKONG

ARCHITECT :

**Iwk&partners**  
A R C H I T E C T S

MAIN CONTRACTOR :

**怡輝建築有限公司**  
**Yee Fai** Building Contractors Ltd.

STRUCTURAL ENGINEER :

**ARUP**  
ALPHA CONSULTING LIMITED  
Steel Structure & Facade Specialist

FAÇADE CONSULTANT:

**ALPHA CONSULTING LIMITED**  
Steel Structure & Facade Specialist

NOTE :

1. ALL DIMENSIONS ARE IN mm.
2. ALL ELEVATIONS ARE VIEWED FROM OUTSIDE.
3. ALL DIMENSIONS TO BE VERIFIED ON SITE BEFORE FABRICATION.

LEGEND :

- X1** --- DETAIL MARK NO.
- X001** --- REFER SHEET NO.
- 1. F.F.L. --- FINISHED FLOOR LEVEL
- 2. S.F.L. --- STRUCTURAL FLOOR LEVEL
- 3. **(R)** --- REVERSED DETAIL
- 4. GLASS LEGEND

EGL-1--8mmHS+12mm AIR GAP+10mmTP THK. I.G.U.  
 EGL-2--10mm THK. CLEAR TEMPERED GLASS  
 EGL-4--10mm THK. TEMPERED ACID ETCHED GLASS  
 EGL-1A--8mmHS+12mm AIR GAP+8mmTP THK. I.G.U.

NO.	DATE	REVISION	REVISION SUBJECT TO ARCHITECTMENT
E	29/11/2021		REVISION SUBJECT TO ARCHITECTMENT
D	02/11/2021		REVISION SUBJECT TO ARCHITECTMENT
C	26/10/2021		REVISION SUBJECT TO ARCHITECTMENT
B	18/10/2021		REVISION SUBJECT TO ARCHITECTMENT
A	27/09/2021		REVISION SUBJECT TO ARCHITECTMENT

JOB NO. : J-856

PROJECT :

PROPOSED DEVELOPMENT ABOVE  
LIGHT RAIL TIN WING STOP-TSWTL  
NO.23,AREA 33,TIN SHUI WAI, N.T.

TITLE :

WINDOW SCHEDULE FOR  
TOWER 3 ALUM. WINDOW

DATE : 02-Aug-21 SCALE : 1:40

DRAWN BY : von CHECKED BY :

**美特 鋸寶有限公司**  
MIDI Aluminium Fabricator Ltd.  
Units 6-8, Sunray Industrial Centre, 1/F  
610 Ona Kwo Ling Road, Kowloon  
Tel:23489211-4 Fax:(852)2727866  
DWG NO. : J856-SD-PW-5305 REV. : E

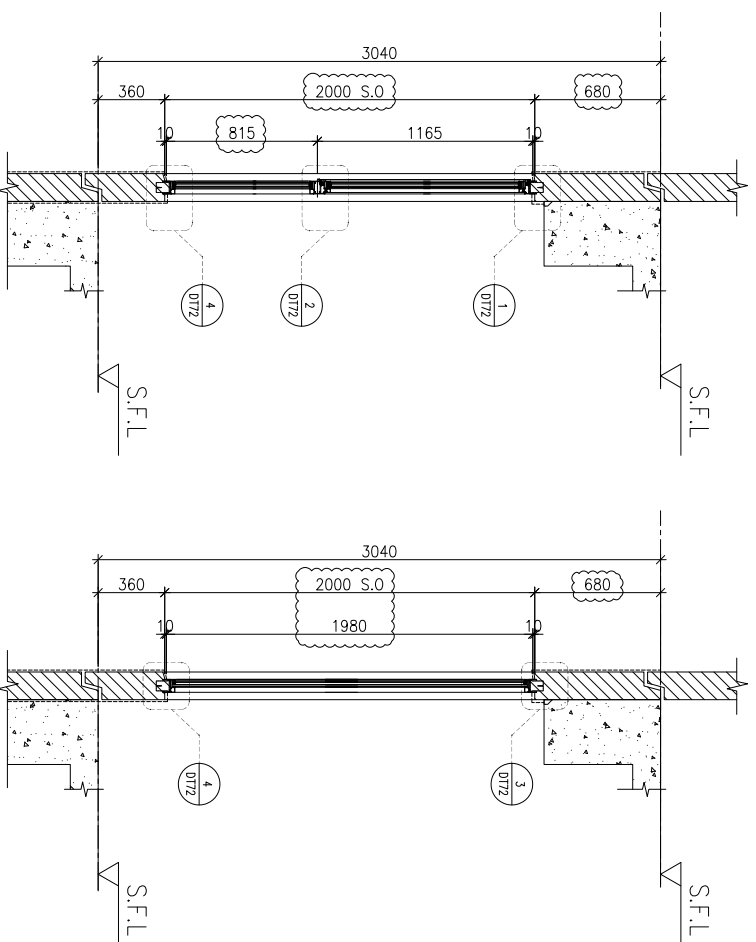
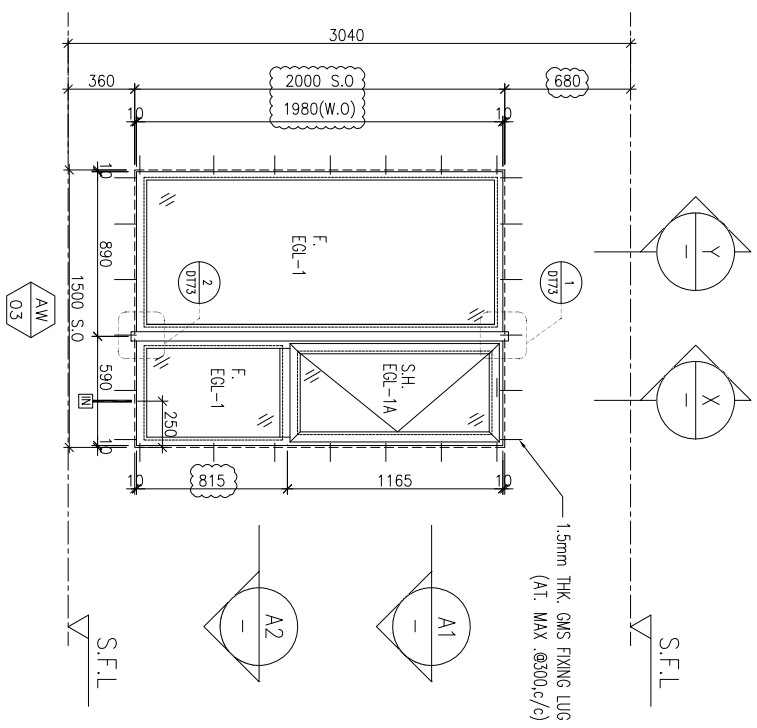

ELEVATION

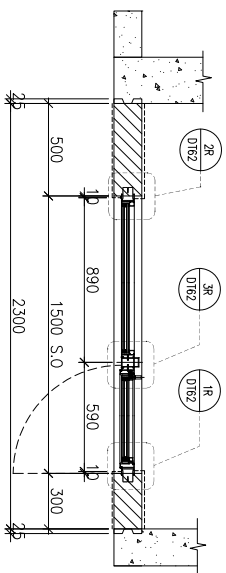

A1 PART PLAN

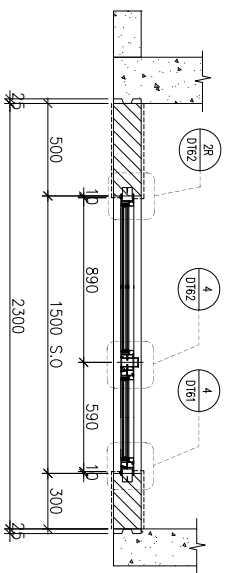

A2 PART PLAN

WINDOW MARK	LOCATION	SECTION	QUANTITY	REMARKS
AW 03	3/F-42/F(4/F,13/F,14/F,24/F,34/F OMITTED) UNIT B6 & 5/F-42/F FOR A15	70mm ALUM. SECTION	35 Nos / 34 Nos	FAÇADE(TYPE T3PF10 FOR 3/F~42/F)
AW 03R	3/F-42/F(4/F,13/F,14/F,24/F,34/F OMITTED) UNIT A2,A5,A8,A9,B7	70mm ALUM. SECTION	35 Nos / 35 Nos / 35 Nos / 35 Nos	FAÇADE(TYPE T3PF10R FOR 3/F~42/F)
	EGL-1,EGL-1A	EGL-1,EGL-1A		

B.O. REF :

CLIENT :

**SUN HUNG KAI**  
REAL ESTATE AGENCY LTD.  
42/F SUN HUNG KAI CENTRE, WANGCHAI, HONGKONG

ARCHITECT :

**lwk&partners**  
a r c h i t e c t s

MAIN CONTRACTOR :

**怡輝建築有限公司**  
Yee Fai Building Contractors Ltd.

STRUCTURAL ENGINEER :

**ARUP**

FAÇADE CONSULTANT:

**ALPHA CONSULTING LIMITED**  
Steel Structure & Façade Specialist

NOTE :

1. ALL DIMENSIONS ARE IN mm.
2. ALL ELEVATIONS ARE VIEWED FROM OUTSIDE.
3. ALL DIMENSIONS TO BE VERIFIED ON SITE BEFORE FABRICATION.

LEGEND :

⊗11 --- DETAIL MARK NO.  
⊗001 --- REFER SHEET NO.

1. F.F.L.--FINISHED FLOOR LEVEL
2. S.F.L.--STRUCTURAL FLOOR LEVEL
3. ⊗R ---REVERSED DETAIL
4. GLASS LEGEND

EGL-1--8mmHS+12mm AIR GAP+10mmTP THK. I.G.U.  
EGL-2--10mm THK. CLEAR TEMPERED GLASS  
EGL-4--10mm THK. TEMPERED ACID ETCHED GLASS  
EGL-1A--8mmHS+12mm AIR GAP+8mmTP THK. I.G.U.

NO.	DATE	REVISION	REVISION SUBJECT TO ARCHITECTMENT
D	29/11/2021	REVISION SUBJECT TO ARCHITECTMENT	None
C	02/11/2021	REVISION SUBJECT TO ARCHITECTMENT	None
B	28/10/2021	REVISION SUBJECT TO ARCHITECTMENT	None
A	27/09/2021	REVISION SUBJECT TO ARCHITECTMENT	None

JOB NO. : J-856

PROJECT :

PROPOSED DEVELOPMENT ABOVE  
LIGHT RAIL TIN WING STOP-TSWTL  
NO.23,AREA 33,TIN SHUI WAI, N.T.

TITLE :

WINDOW SCHEDULE FOR  
TOWER 3 ALUM. WINDOW

DATE : 02-Aug-21 SCALE : 1:40

DRAWN BY : Ivon CHECKED BY :

**美特 鋁質有限公司**  
MIDI ALUMINUM FABRICATOR LTD.  
Units 6-8, Sunray Industrial Centre, 1/F  
610 Cha Kwo Ling Road, Kowloon  
Tel:23489211-4 Fax:(852)27277666

DWG NO. : J856-SD-PW-5306 REV. : D

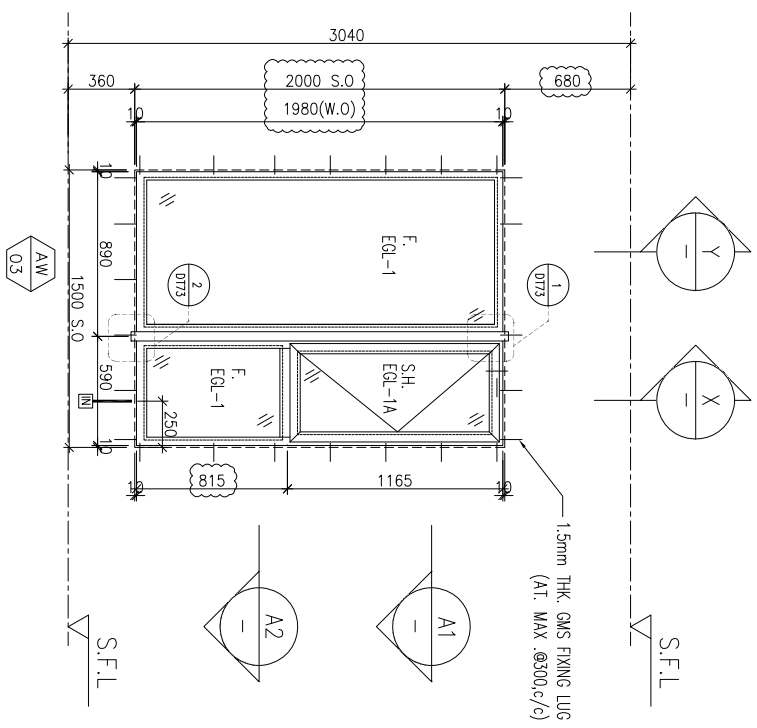

ELEVATION

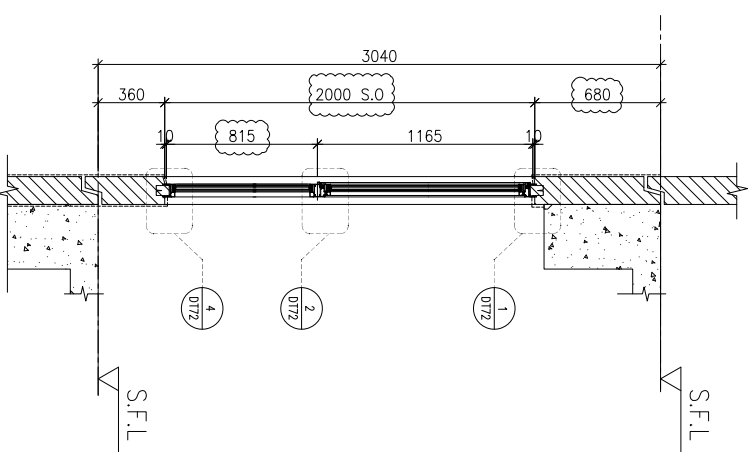

PART SECTION

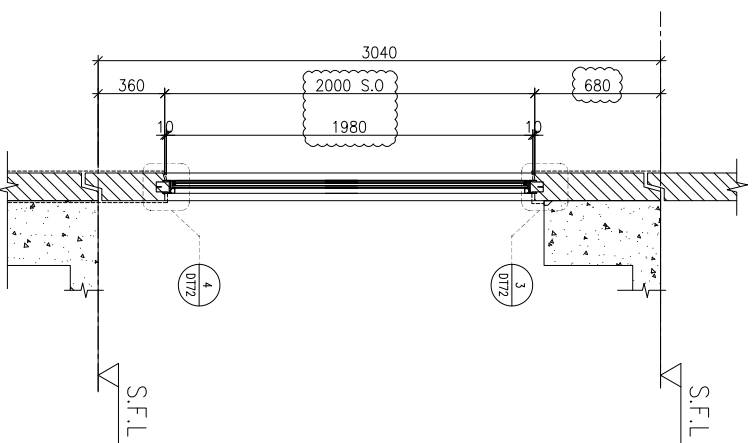

PART SECTION

A1 PART PLAN

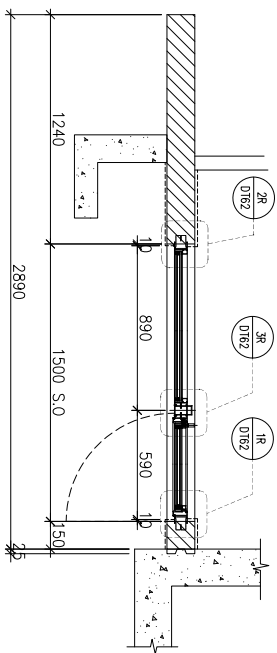

A2 PART PLAN

A2 PART PLAN

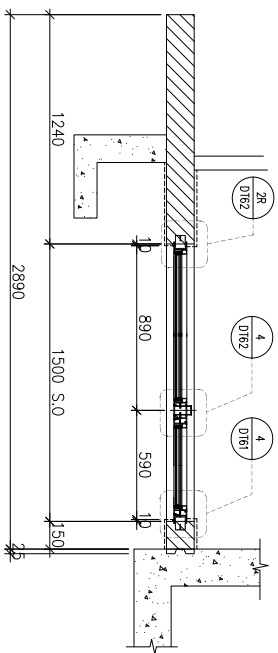

WINDOW MARK **AW 03**

LOCATION 3/F-42/F(4/F,13/F,14/F,24/F,34/F OMITTED) UNIT B10

SECTION 70mm ALUM. SECTION

GLAZING EGL-1,EGL-1A

QUANTITY 35 Nos

REMARKS FACADE(TYPE T3PF11R FOR 3/F~42/F)

B.O. REF :

CLIENT :

**SUN HUNG KAI**  
REAL ESTATE AGENCY LTD.  
42/F SUN HUNG KAI CENTRE, WANGCHAI, HONGKONG

ARCHITECT :  
**Iwk&partners**  
A R C H I T E C T S

MAIN CONTRACTOR :  
**怡輝建築有限公司**  
Yee Fai Building Contractors Ltd.

STRUCTURAL ENGINEER :

ALPHA CONSULTING LIMITED  
Steel Structure & Facade Specialist

ALPHA CONSULTING LIMITED  
Steel Structure & Facade Specialist

NOTE :  
1. ALL DIMENSIONS ARE IN mm.  
2. ALL ELEVATIONS ARE VIEWED FROM OUTSIDE.  
3. ALL DIMENSIONS TO BE VERIFIED ON SITE BEFORE FABRICATION.

LEGEND :

①②③④ --- DETAIL MARK NO.  
X001 --- REFER SHEET NO.

1. F.F.L.--FINISHED FLOOR LEVEL  
2. S.F.L.--STRUCTURAL FLOOR LEVEL  
3. (R) --- REVERSED DETAIL  
4. GLASS LEGEND

EGL-1--8mmHS+12mm AIR GAP+10mmTP THK. I.G.U.  
EGL-2--10mm THK. CLEAR TEMPERED GLASS  
EGL-4--10mm THK. TEMPERED ACID ETCHED GLASS  
EGL-1A--8mmHS+12mm AIR GAP+8mmTP THK. I.G.U.

NO.	DATE	REVISION
D	29/11/2021	REVISION SUBJECT TO ARCHITECTMENT
C	02/11/2021	REVISION SUBJECT TO ARCHITECTMENT
B	28/10/2021	REVISION SUBJECT TO ARCHITECTMENT
A	27/09/2021	REVISION SUBJECT TO ARCHITECTMENT

JOB NO. : J-856

PROJECT :  
PROPOSED DEVELOPMENT ABOVE  
LIGHT RAIL TIN WING STOP-TSWTL  
NO.23,AREA 33,TIN SHUI WAI, N.T.

TITLE :  
WINDOW SCHEDULE FOR  
TOWER 3 ALUM. WINDOW

DATE : 02-Aug-21 SCALE : 1:40

DRAWN BY : Ivon CHECKED BY :

**美特經貿有限公司**  
MIDI Aluminium Fabricator Ltd.  
Units 6-8, Sunray Industrial Centre, 1/F  
610 Ona Kwo Ling Road, Kowloon  
Tel:23489211-4 Fax:(852)27277666

DWG NO. : J856-SD-PW-5307 REV. : D

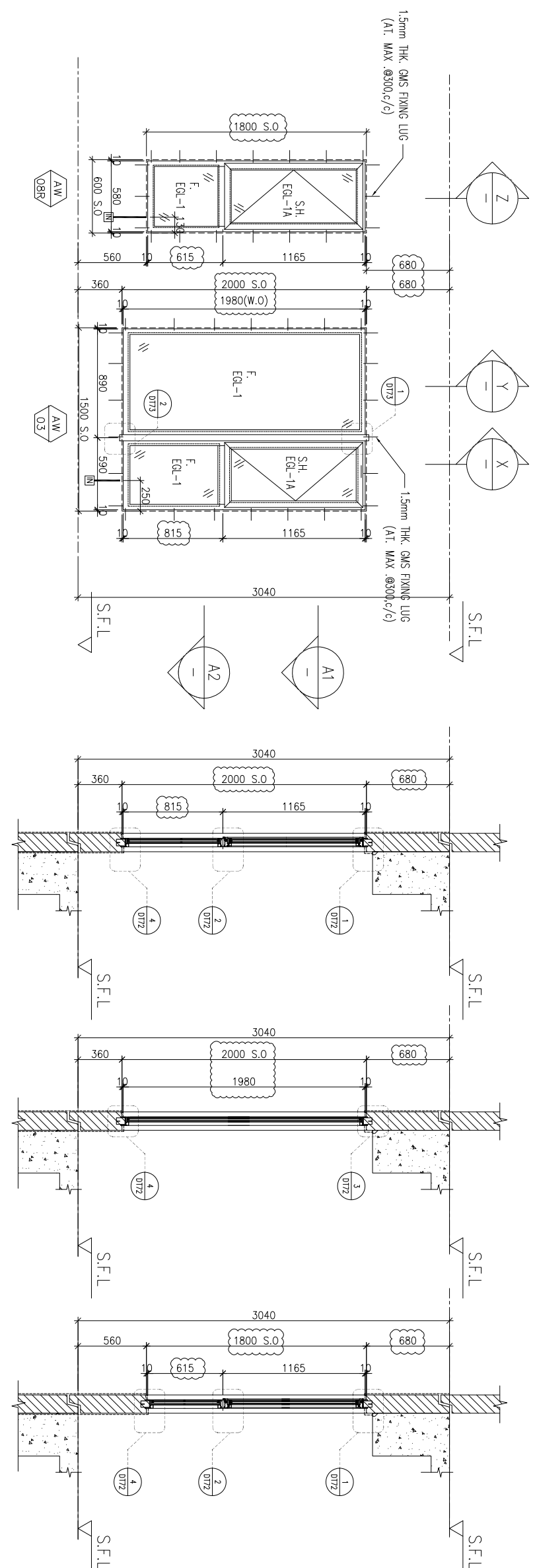

ELEVATION

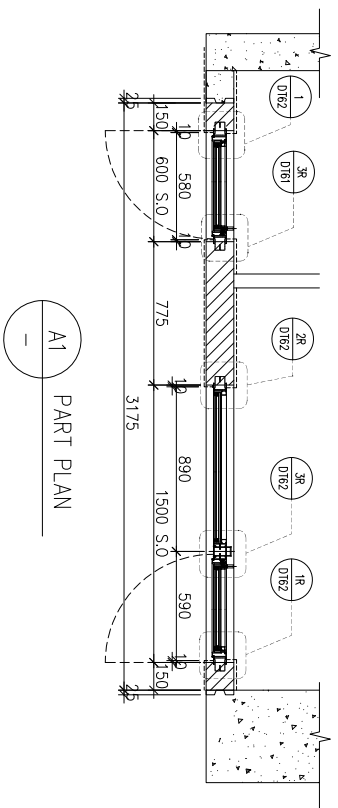

A1 PART PLAN

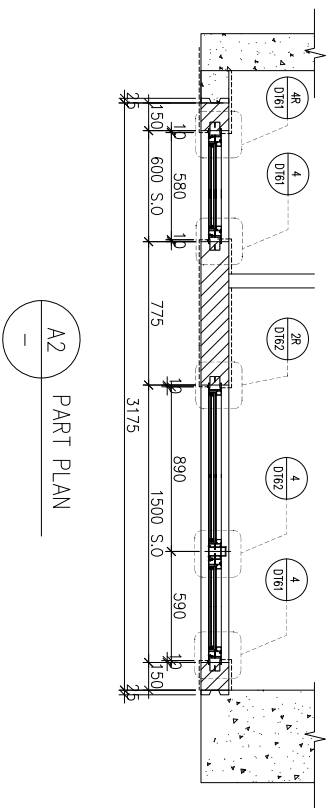

A2 PART PLAN

WINDOW MARK	AW 03R	AW 08
LOCATION	3/F-42/F(4/F,13/F,14/F,24/F,34/F OMITTED) UNIT A7	
SECTION	70mm ALUM. SECTION	
GLAZING	EGL-1,EGL-1A	
QUANTITY	35 Nos	
REMARKS	FACADE TYPE T3PF15 FOR 3/F~42/F)	

1. ALL DIMENSIONS ARE IN mm.
2. ALL ELEVATIONS ARE VIEWED FROM OUTSIDE.
3. ALL DIMENSIONS TO BE VERIFIED ON SITE BEFORE FABRICATION.

- (X1) DETAIL MARK NO.
- (X001) REFER SHEET NO.
- 1. F.F.L. -- FINISHED FLOOR LEVEL
- 2. S.F.L. -- STRUCTURAL FLOOR LEVEL
- 3. (R) -- REVERSED DETAIL
- 4. GLASS LEGEND

EGL-1--8mmHS+12mm AIR GAP+10mmTP THK. I.G.U.  
 EGL-2--10mm THK. CLEAR TEMPERED GLASS  
 EGL-4--10mm THK. TEMPERED ACID ETCHED GLASS  
 EGL-1A--8mmHS+12mm AIR GAP+8mmTP THK. I.G.U.

NO.	DATE	REVISION	REVISION SUBJECT TO ARCHITECTMENT
E	29/11/2021		REVISION SUBJECT TO ARCHITECTMENT
D	02/11/2021		REVISION SUBJECT TO ARCHITECTMENT
C	26/10/2021		REVISION SUBJECT TO ARCHITECTMENT
B	18/10/2021		REVISION SUBJECT TO ARCHITECTMENT
A	27/09/2021		REVISION SUBJECT TO ARCHITECTMENT

JOB NO. : J-856

PROJECT :  
 PROPOSED DEVELOPMENT ABOVE  
 LIGHT RAIL TIN WING STOP TSWTL  
 NO.23,AREA 33,TIN SHUI WAI, N.T.

TITLE :  
 WINDOW SCHEDULE FOR  
 TOWER 3 ALUM. WINDOW

DATE : 02-Aug-21 SCALE : 1:40

DRAWN BY : Ivon CHECKED BY :

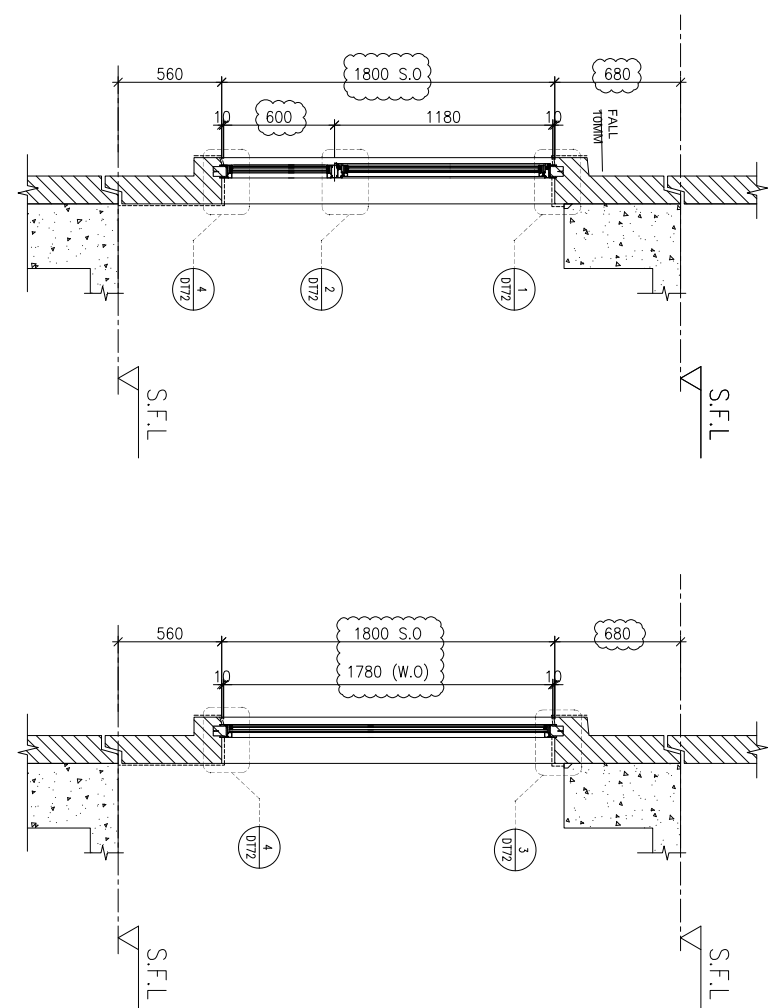
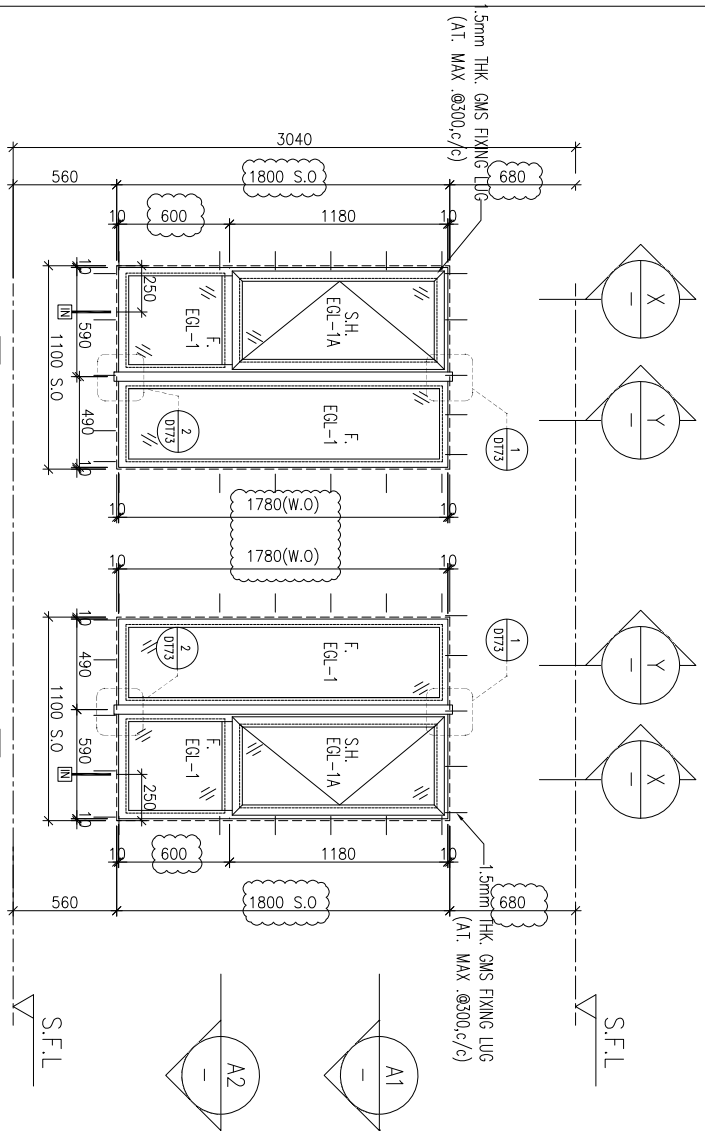

ELEVATION

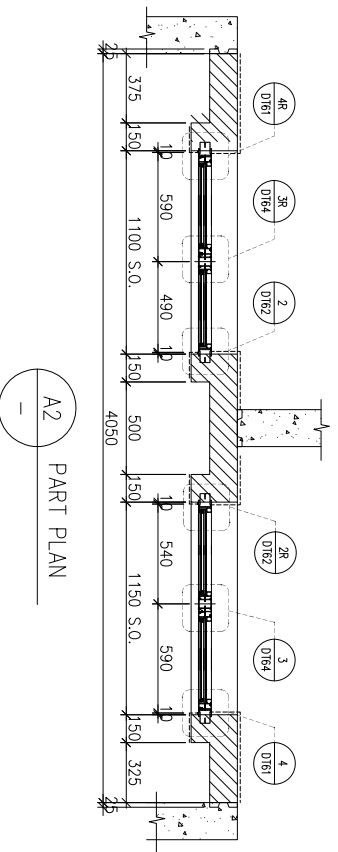
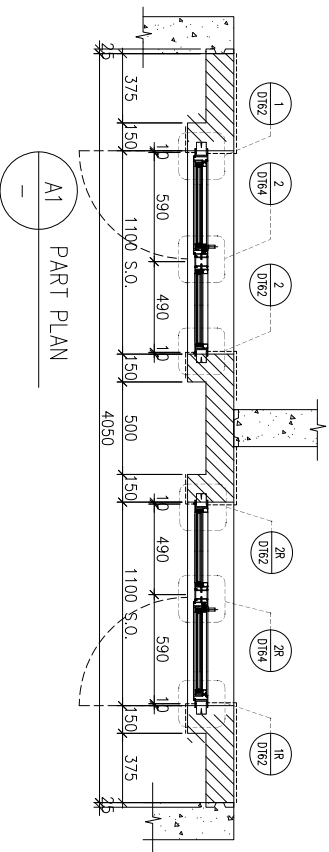

WINDOW MARK	AW 02	AW 02R
LOCATION	3/F-42/F(4/F,13/F,14/F,24/F,34/F OMITTED) UNIT A3&A5, A12&A13	
SECTION	70mm ALUM. SECTION	
GLAZING	EGL-1,EGL-1A	
QUANTITY	35 Nos / 35 Nos	
REMARKS	FAÇADE TYPE T3PF16 FOR 3/F~42/F)	

B.O. REF :

CLIENT :

**SUN HUNG KAI**  
**REAL ESTATE AGENCY LTD.**  
42/F SUN HUNG KAI CENTRE, WANGCHAI, HONGKONG

ARCHITECT :

**lwk&partners**  
a r c h i t e c t s

MAIN CONTRACTOR :

**怡輝建築有限公司**  
**Yee Fai Building Contractors Ltd.**

STRUCTURAL ENGINEER :

**ARUP**

FAÇADE CONSULTANT:

**ALPHA CONSULTING LIMITED**  
Steel Structure & Façade Specialist

NOTE :

1. ALL DIMENSIONS ARE IN mm.
2. ALL ELEVATIONS ARE VIEWED FROM OUTSIDE.
3. ALL DIMENSIONS TO BE VERIFIED ON SITE BEFORE FABRICATION.

LEGEND :

**X1** — DETAIL MARK NO.  
**X001** — REFER SHEET NO.

1. F.F.L. — FINISHED FLOOR LEVEL
2. S.F.L. — STRUCTURAL FLOOR LEVEL
3. **⊗** — REVERSED DETAIL
4. GLASS LEGEND

EGL-1—8mmHS+12mm AIR GAP+10mmTP THK. I.G.U.  
EGL-2—10mm THK. CLEAR TEMPERED GLASS  
EGL-4—10mm THK. TEMPERED ACID ETCHED GLASS  
EGL-1A—8mmHS+12mm AIR GAP+8mmTP THK. I.G.U.

NO.	DATE	REVISION
E	29/11/2021	REVISION SUBJECT TO ARCH/COMMITMENT
D	02/11/2021	REVISION SUBJECT TO ARCH/COMMITMENT
C	26/10/2021	REVISION SUBJECT TO ARCH/COMMITMENT
B	18/10/2021	REVISION SUBJECT TO ARCH/COMMITMENT
A	27/09/2021	REVISION SUBJECT TO ARCH/COMMITMENT

JOB NO. : J-856

PROJECT :

PROPOSED DEVELOPMENT ABOVE  
LIGHT RAIL TIN WING STOP-TSWTL  
NO.23,AREA 33,TIN SHUI WAI, N.T.

TITLE :

WINDOW SCHEDULE FOR  
TOWER 3 ALUM. WINDOW

DATE : 02-Aug-21 SCALE : 1:40

DRAWN BY : Ivon CHECKED BY :

**美特鋁寶有限公司**  
**MIDI ALUMINIUM FABRICATOR LTD.**  
Units 6-8, Sunray Industrial Centre, 1/F  
610 Ona Kwo Ling Road, Kowloon  
Tel:23489211-4 Fax:(852)27277666

DWG NO. : J856-SD-PW-5309 REV. : E

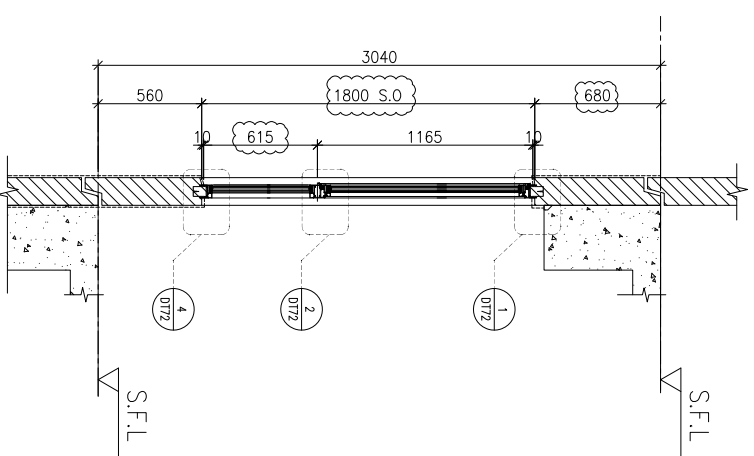
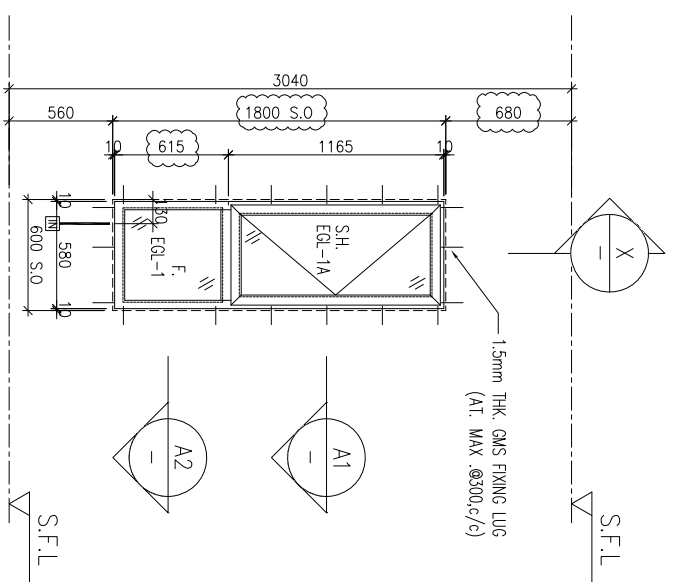

ELEVATION

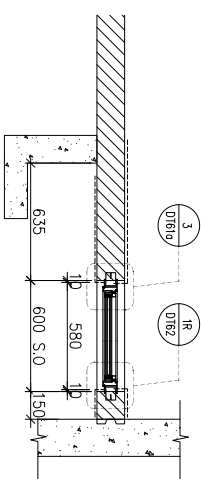

A1 PART PLAN

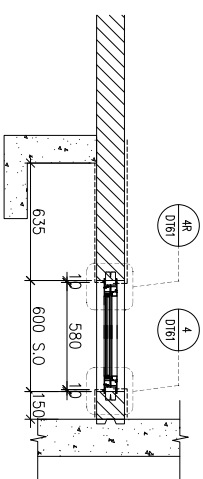

A2 PART PLAN

WINDOW MARK	AW 08
LOCATION	3/F-42/F(4/F,13/F,14/F,24/F,34/F OMITTED) UNIT B2
SECTION	70mm ALUM. SECTION
GLAZING	EGL-1,EGL-1A
QUANTITY	35 Nos
REMARKS	FAÇADE(TYPE T3PF18 FOR 3/F~42/F)

B.O. REF :

CLIENT :

**SUN HUNG KAI**  
REAL ESTATE AGENCY LTD.  
42/F SUN HUNG KAI CENTRE, WANCHAI, HONGKONG

ARCHITECT :

**IWK&partners**  
a r c h i t e c t s

MAIN CONTRACTOR :

**怡輝建築有限公司**  
Yee Fai Building Contractors Ltd.

STRUCTURAL ENGINEER :

**ARUP**

FAÇADE CONSULTANT:

**ALPHA CONSULTING LIMITED**  
Steel Structure & Façade Specialist

NOTE :

1. ALL DIMENSIONS ARE IN mm.
2. ALL ELEVATIONS ARE VIEWED FROM OUTSIDE.
3. ALL DIMENSIONS TO BE VERIFIED ON SITE BEFORE FABRICATION.

LEGEND :

- X1 --- DETAIL MARK NO.
- X001 --- REFER SHEET NO.
- 1. F.F.L.--FINISHED FLOOR LEVEL
- 2. S.F.L.--STRUCTURAL FLOOR LEVEL
- 3. (R) --REVERSED DETAIL

4. GLASS LEGEND
- EG1-1--8mmHS+12mm AIR GAP+10mmTP THK. LG.U.
- EG1-2--10mm THK. CLEAR TEMPERED GLASS
- EG1-4--10mm THK. TEMPERED ACID ETCHED GLASS
- EG1-1A-8mmHS+12mm AIR GAP+8mmTP THK. LG.U.

NO.	DATE	REVISION	REVISION SUBJECT TO ARCH/COMMENT	BY
C	29/11/2021	REVISION SUBJECT TO ARCH/COMMENT		YWN
B	18/10/2021	REVISION SUBJECT TO ARCH/COMMENT		YWN
A	12/10/2021	REVISION SUBJECT TO ARCH/COMMENT		YWN

JOB NO. : J-856

PROJECT :

PROPOSED DEVELOPMENT ABOVE  
LIGHT RAIL TIN WING STOP TSWTL  
NO.23,AREA 33,TIN SHUI WAI, N.T.

TITLE :

WINDOW SCHEDULE FOR  
TOWER 3 ALUM. WINDOW

DATE : 02-Aug-21 SCALE : 1:40

DRAWN BY : IYWN CHECKED BY :

**美特鋁質有限公司**  
MIDI ALUMINIUM FABRICATOR LTD.  
Units 6-8, Sunny Industrial Centre, 1/F  
610 Che Kwo Ling Road, Kowloon  
Tel:23489211-4 Fax:85227272666

DWG NO. : 856-S0-PW-5310 REV. : C

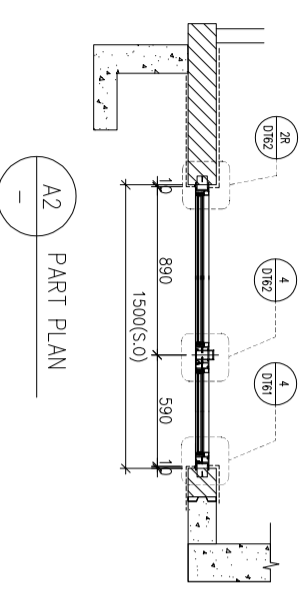
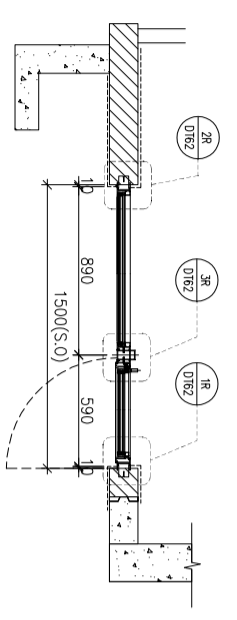
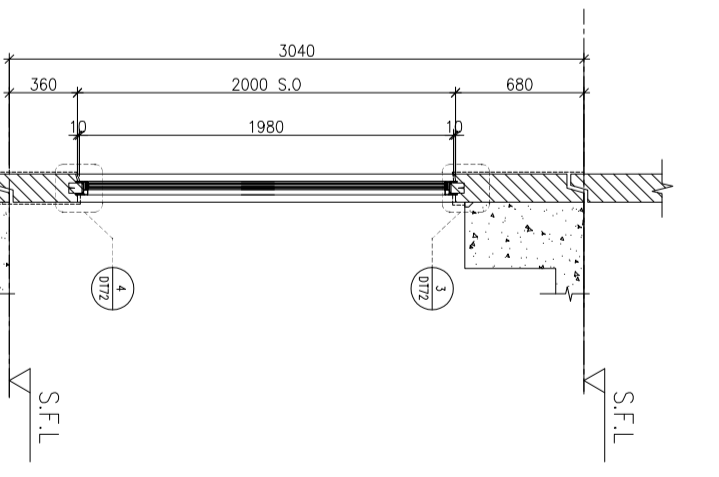
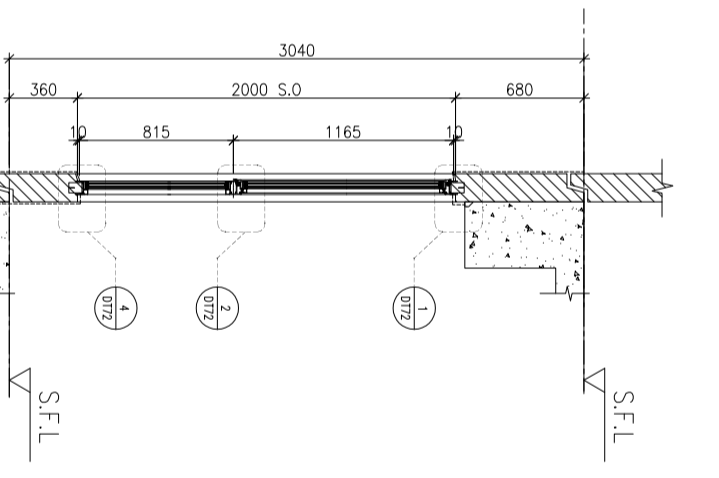
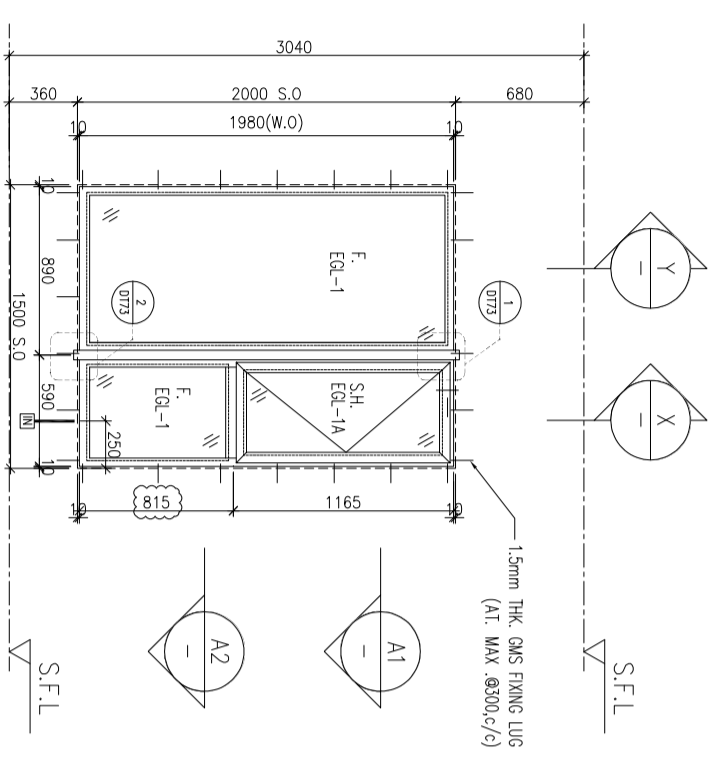

ELEVATION

WINDOW MARK

LOCATION  
SECTION  
GLAZING  
QUANTITY  
REMARKS

WINDOW MARK	AW 03
LOCATION	3/F~42/F(4/F,13/F,14/F,24/F,34/F OMITTED) UNIT A11
SECTION	70mm ALUM. SECTION
GLAZING	EGL-1,EGL-1A
QUANTITY	35 Nos
REMARKS	FAÇADE(TYPE T3PF04 FOR 3/F~42/F)

WINDOW MARK	AW 03B
LOCATION	3/F~42/F(4/F,13/F,14/F,24/F,34/F OMITTED) UNIT A12 ,B9
SECTION	70mm ALUM. SECTION
GLAZING	EGL-1,EGL-1A
QUANTITY	35 Nos/35 Nos
REMARKS	FAÇADE(TYPE T3PF04R FOR 3/F~42/F)

B.O. REF :

CLIENT :

**SUN HUNG KAI**  
REAL ESTATE AGENCY LTD.  
42/F SUN HUNG KAI CENTRE, WANGCHAI, HONGKONG

ARCHITECT :

**IWK&partners**  
a r c h i t e c t s

MAIN CONTRACTOR :

**怡輝建築有限公司**  
Yee Fai Building Contractors Ltd.

STRUCTURAL ENGINEER :

**ARUP**

FAÇADE CONSULTANT:

**ALPHA CONSULTING LIMITED**  
Steel Structure & Façade Specialist

NOTE :

1. ALL DIMENSIONS ARE IN mm.
2. ALL ELEVATIONS ARE VIEWED FROM OUTSIDE.
3. ALL DIMENSIONS TO BE VERIFIED ON SITE BEFORE FABRICATION.

LEGEND :

- X1 --- DETAIL MARK NO.
- X001 --- REFER SHEET NO.
- 1. F.F.L.--FINISHED FLOOR LEVEL
- 2. S.F.L.--STRUCTURAL FLOOR LEVEL
- 3. (R) ---REVERSED DETAIL
- 4. GLASS LEGEND

EQ1-1--8mmHS+12mm AIR GAP+10mmTP THK. I.G.U.  
 EQ1-2--10mm THK. CLEAR TEMPERED GLASS  
 EQ1-4--10mm THK. CLEAR TEMPERED ACID ETCHED GLASS  
 EQ1-1A-8mmHS+12mm AIR GAP+8mmTP THK. I.G.U.

NO.	DATE	REVISION SUBJECT TO ARCH COMMENT	BY
B	29/11/2021	REVISION SUBJECT TO ARCH COMMENT	lvn
A	18/10/2021	REVISION SUBJECT TO ARCH COMMENT	lvn

JOB NO. : J-856

PROJECT :

PROPOSED DEVELOPMENT ABOVE  
LIGHT RAIL TIN WING STOP TSWTL  
NO.23,AREA 33,TIN SHUI WAI, N.T.

TITLE :

WINDOW SCHEDULE FOR  
TOWER 3 ALUM. WINDOW

DATE : 02-Aug-21 SCALE : 1:40

DRAWN BY : lvn CHECKED BY :

**美特鋁質有限公司**  
MIDI ALUMINIUM FABRICATOR LTD.  
Units 6-8, Sunny Industrial Centre, 1/F  
610 Che Kwo Ling Road, Kowloon  
Tel:23489211-4 Fax:85227272666

DWG NO. : 856-SD-PW-5311 REV. : B

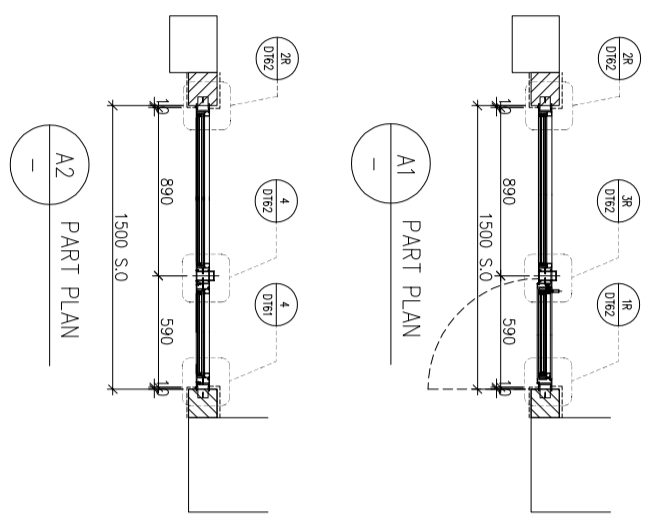
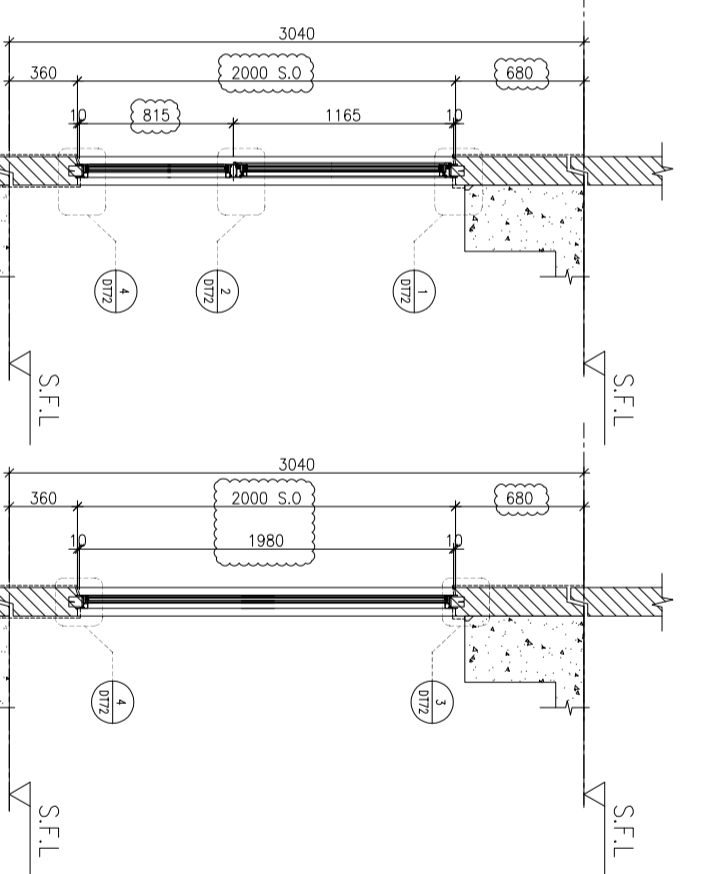
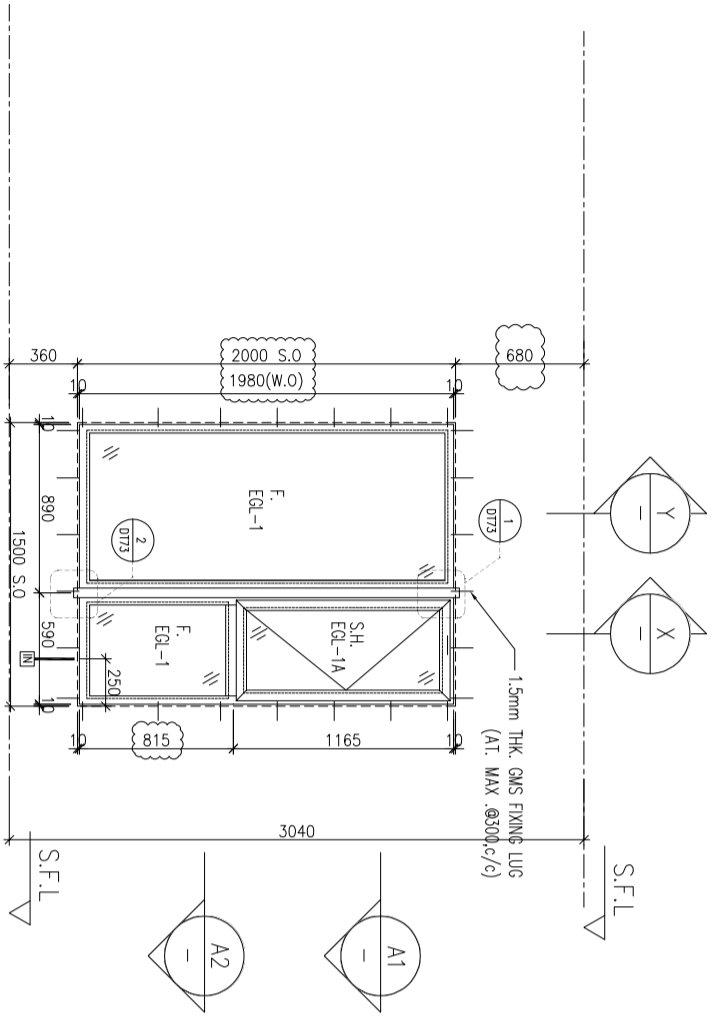

ELEVATION

WINDOW MARK	AW 03
LOCATION	3/F~42/F(4/F,13/F,14/F,24/F,34/F OMITTED) UNIT A1
SECTION	70mm ALUM. SECTION
GLAZING	EGL-1,EGL-1A
QUANTITY	35 Nos
REMARKS	FAÇADE(TYPE T3PF15 FOR 3/F~42/F)

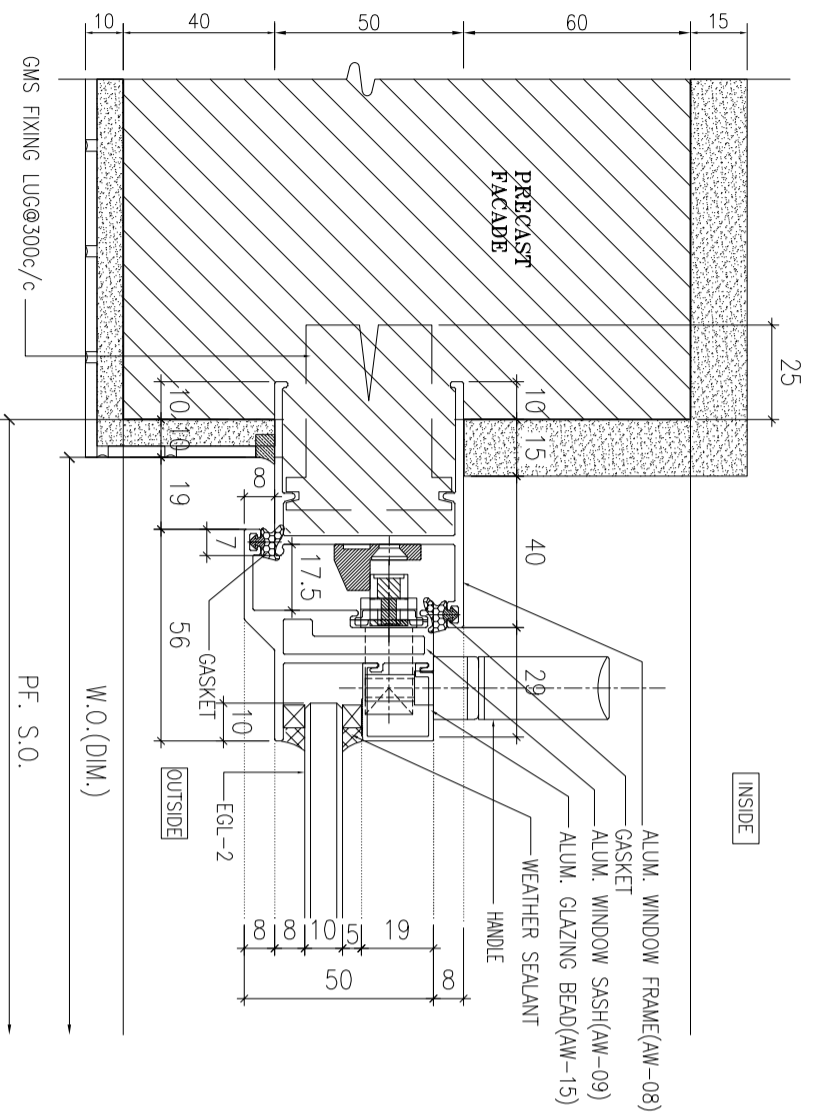

1 HORIZONTAL DETAIL  
SCALE 1:2

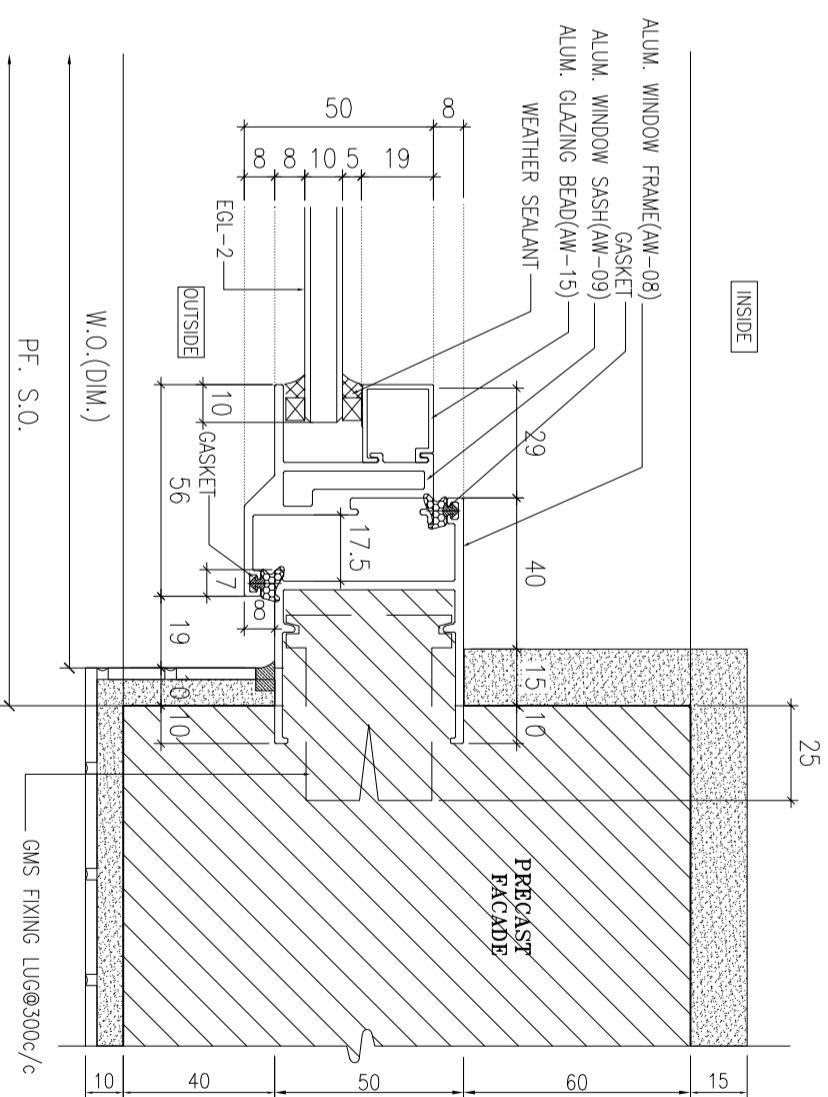

2 HORIZONTAL DETAIL  
SCALE 1:2

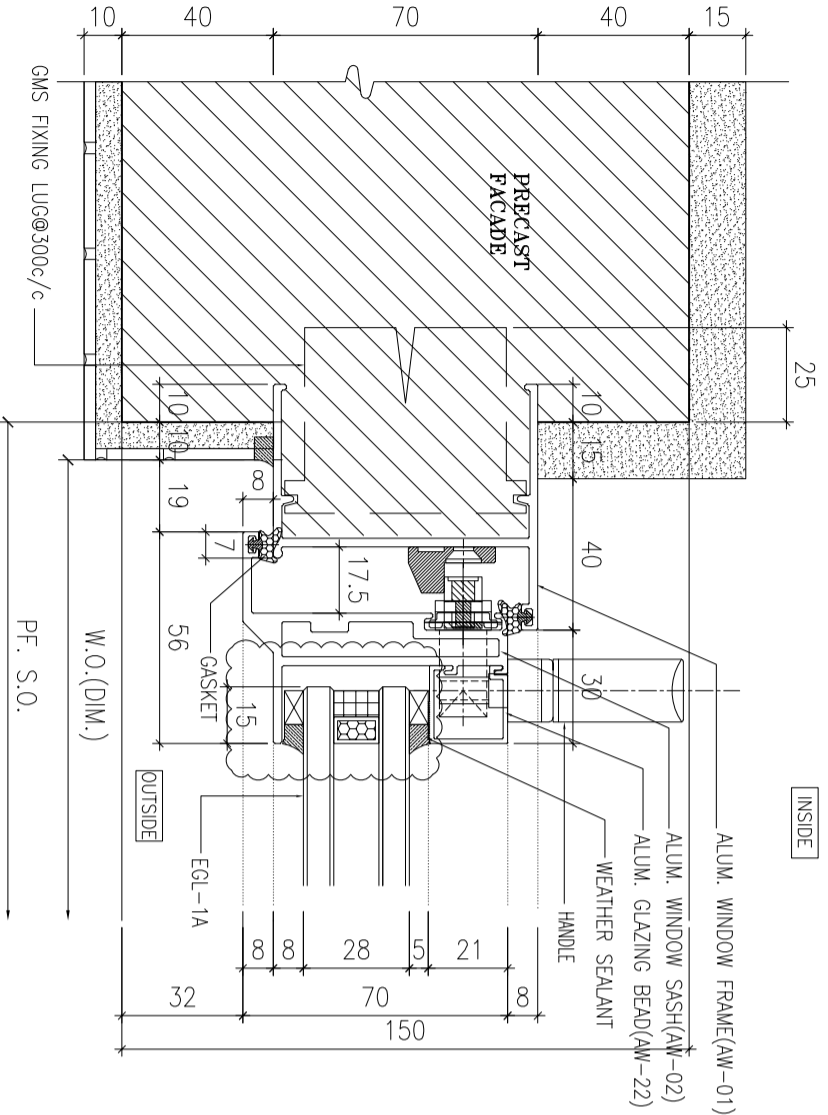

3 HORIZONTAL DETAIL  
SCALE 1:2

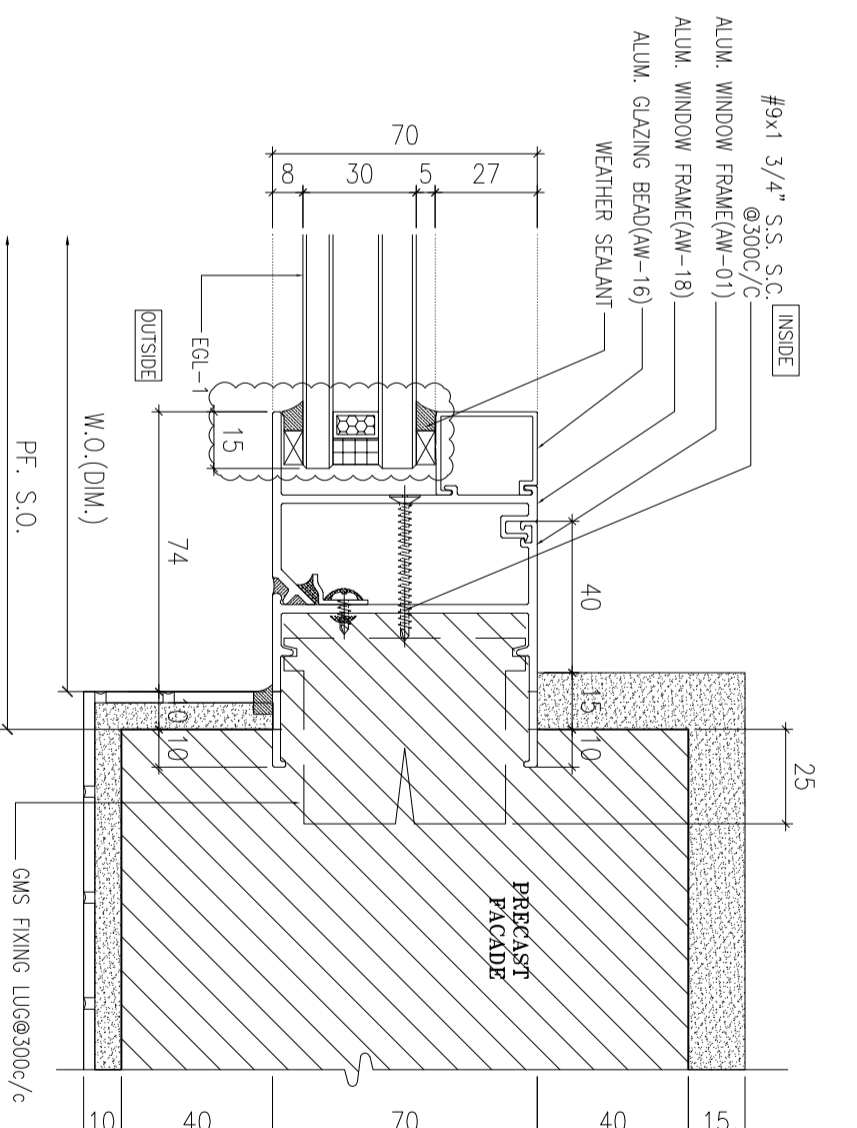

4 HORIZONTAL DETAIL  
SCALE 1:2

B.O. REF :

CLIENT :  
**SUN HUNG KAI**  
REAL ESTATE AGENCY LTD.  
42/F SUN HUNG KAI CENTRE, WANCHAI, HONGKONG

ARCHITECT :  
**IWK&partners**  
a r c h i t e c t s

MAIN CONTRACTOR :  
**怡輝建築有限公司**  
Yee Fai Building Contractors Ltd.

STRUCTURAL ENGINEER :  
**ARUP**

FAÇADE CONSULTANT:  
**ALPHA CONSULTING LIMITED**  
Steel Structure & Façade Specialist

NOTE :  
1. ALL DIMENSIONS ARE IN mm.  
2. ALL ELEVATIONS ARE VIEWED FROM OUTSIDE.  
3. ALL DIMENSIONS TO BE VERIFIED ON SITE BEFORE FABRICATION.

LEGEND :  
X1 --- DETAIL MARK NO.  
X001 --- REFER SHEET NO.

1. F.F.L.--FINISHED FLOOR LEVEL  
2. S.F.L.--STRUCTURAL FLOOR LEVEL  
3. (R) ---REVERSED DETAIL  
4. GLASS LEGEND  
EGL-1--9mmHS+12mm AIR GAP+10mmTP THK. I.G.U.  
EGL-2--10mm THK. CLEAR TEMPERED GLASS  
EGL-4--10mm THK. TEMPERED ACID ETCHED GLASS  
EGL-1A--8mmHS+12mm AIR GAP+8mmTP THK. I.G.U.

NO.	DATE	REVISION SUBJECT TO ARCH/COMMENT	BY
B	02/11/2021	REVISION SUBJECT TO ARCH/COMMENT	lvn
A	30/10/2021	REVISION SUBJECT TO ARCH/COMMENT	lvn

JOB NO. : J-856  
PROJECT : PROPOSED DEVELOPMENT ABOVE LIGHT RAIL TIN WING STOP TSWTL NO.23,AREA 33,TIN SHUI WAI, N.T.  
TITLE : TYPICAL DETAILS FOR ALUM. WINDOW

DATE : 02-Aug-21 SCALE : 1:40  
DRAWN BY : lvon CHECKED BY :

**美特鋁質有限公司**  
MIDI ALUMINIUM FABRICATOR LTD.  
Units 6-8, Sunny Industrial Centre, 1/F  
610 Che Kwo Ling Road, Kowloon  
Tel:23489211-4 Fax:8522727666  
DWG NO. : J856-SD-PW-DT61 REV. : B





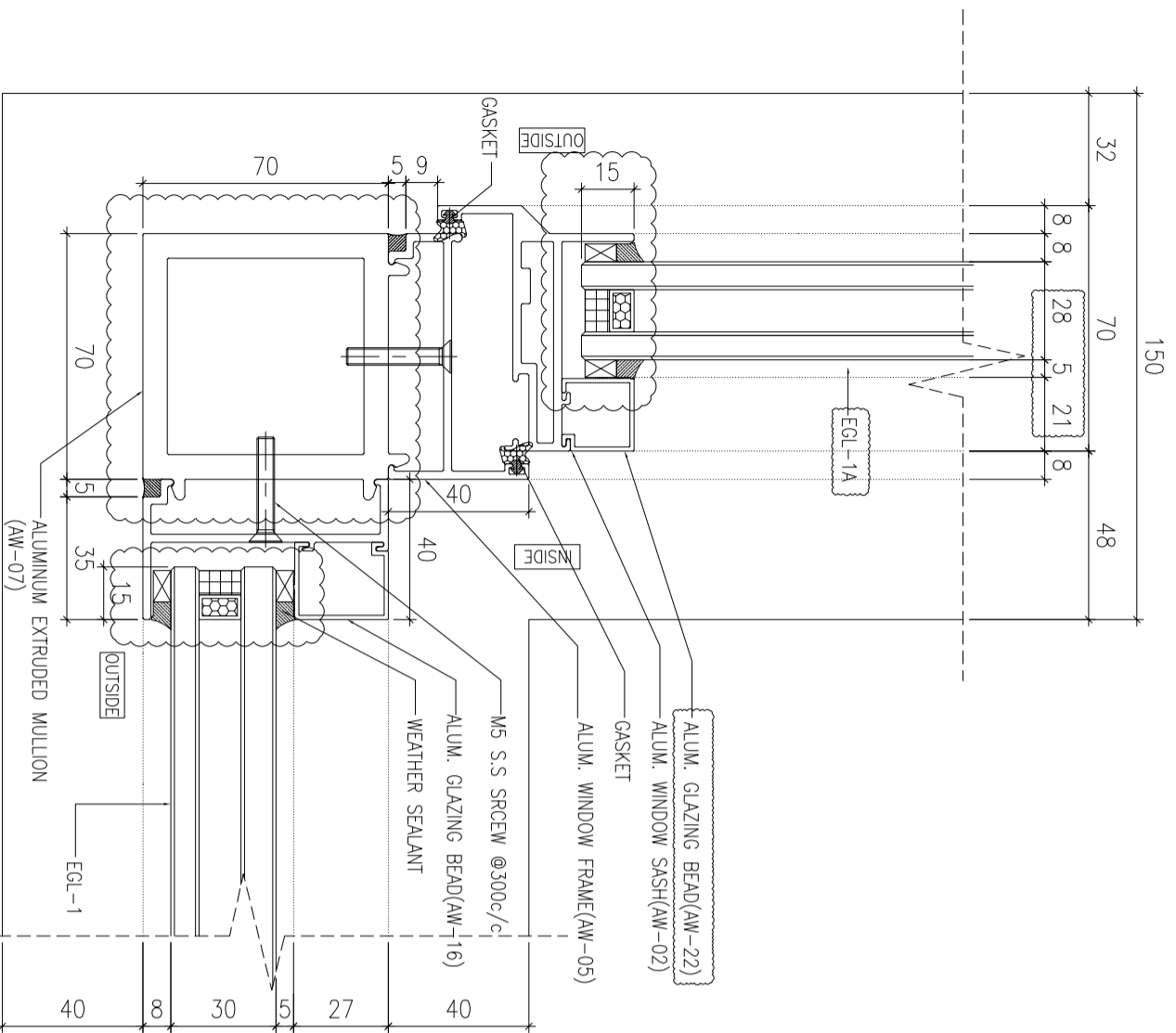

1 HORIZONTAL DETAIL  
SCALE 1:2

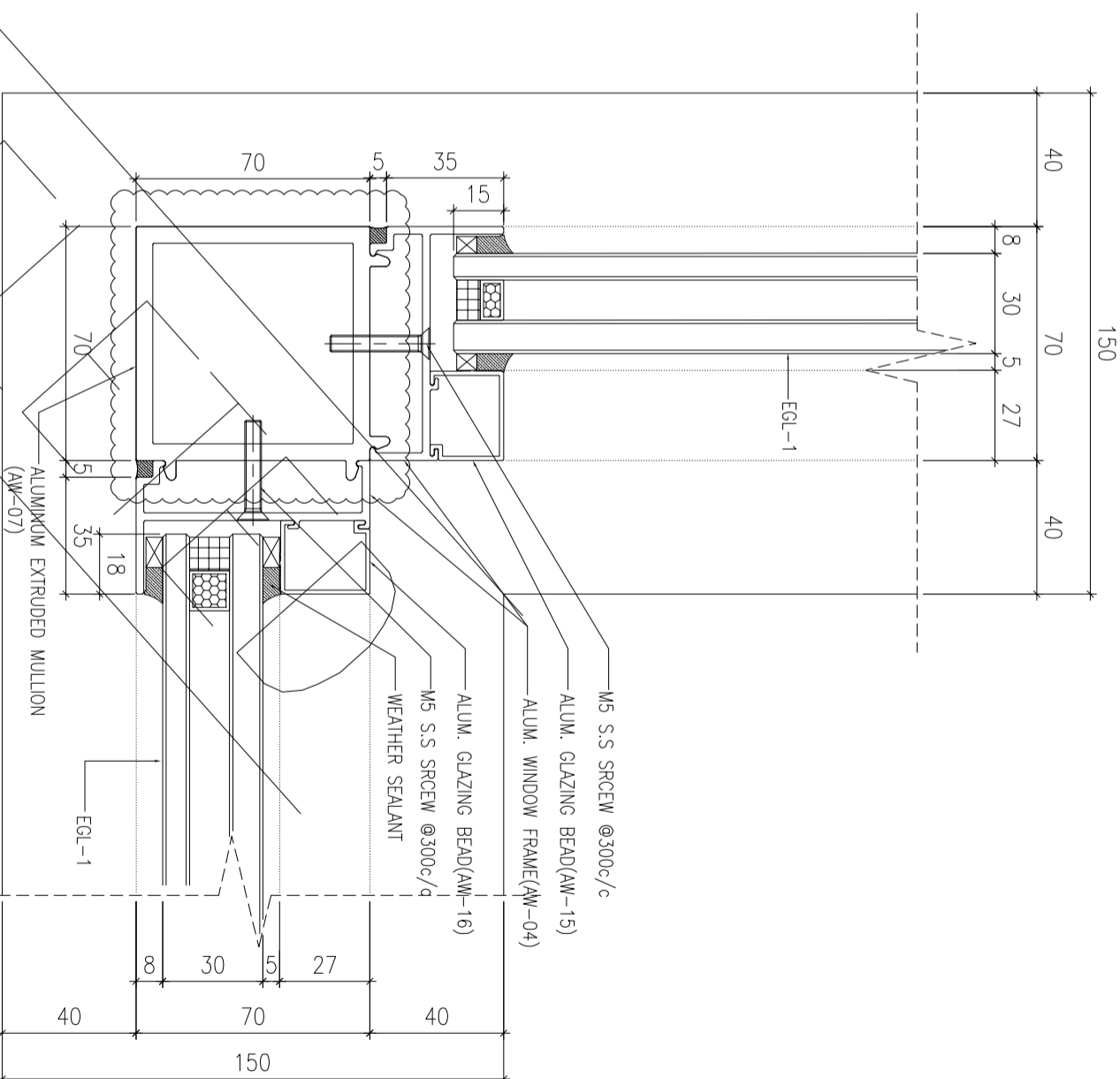

2 HORIZONTAL DETAIL  
SCALE 1:2

B.O. REF :

CLIENT :

**SUN HUNG KAI**  
REAL ESTATE AGENCY LTD.  
42/F SUN HUNG KAI CENTRE, WANGCHAI, HONGKONG

ARCHITECT :

**IWK&partners**  
a r c h i t e c t s

MAIN CONTRACTOR :

**怡輝建築有限公司**  
**Yee Fai Building Contractors Ltd.**

STRUCTURAL ENGINEER :

FAÇADE CONSULTANT:  
**ARUP**  
**ALPHA CONSULTING LIMITED**  
Steel Structure & Façade Specialist

**ALPHA CONSULTING LIMITED**  
Steel Structure & Façade Specialist

NOTE :

1. ALL DIMENSIONS ARE IN mm.
2. ALL ELEVATIONS ARE VIEWED FROM OUTSIDE.
3. ALL DIMENSIONS TO BE VERIFIED ON SITE BEFORE FABRICATION.

LEGEND :

X1 -- DETAIL MARK NO.  
X001 -- REFER SHEET NO.

1. F.F.L.--FINISHED FLOOR LEVEL
2. S.F.L.--STRUCTURAL FLOOR LEVEL
3. (R) --REVERSED DETAIL

4. GLASS LEGEND

- EGL-1--9mmHS+12mm AIR GAP+10mmTP THK. I.G.U.  
EGL-2--10mm THK. CLEAR TEMPERED GLASS  
EGL-4--10mm THK. TEMPERED ACID ETCHED GLASS  
EGL-1A--8mmHS+12mm AIR GAP+8mmTP THK. I.G.U.

NO.	DATE	REVISION
C	02/11/2021	REVISION SUBJECT TO ARCH.COMMENT
B	30/09/2021	REVISION SUBJECT TO ARCH.COMMENT
A	30/09/2021	REVISION SUBJECT TO ARCH.COMMENT

JOB NO. : J-856

PROJECT :

PROPOSED DEVELOPMENT ABOVE  
LIGHT RAIL TIN WING STOP TSWTL  
NO.23,AREA 33,TIN SHUI WAI, N.T.

TITLE : TYPICAL DETAILS FOR

ALUM. WINDOW

DATE : 02-Aug-21 SCALE : 1:40

DRAWN BY : Ivon CHECKED BY :

**MIDI ALUMINIUM FABRICATOR LTD.**  
Units 6-8, Sunny Industrial Centre, 1/F  
610 Che Kwo Ling Road, Kowloon  
Tel:23489211-4 Fax:8522727666  
DWG NO. : JB56-SD-PW-DT63 REV. : C

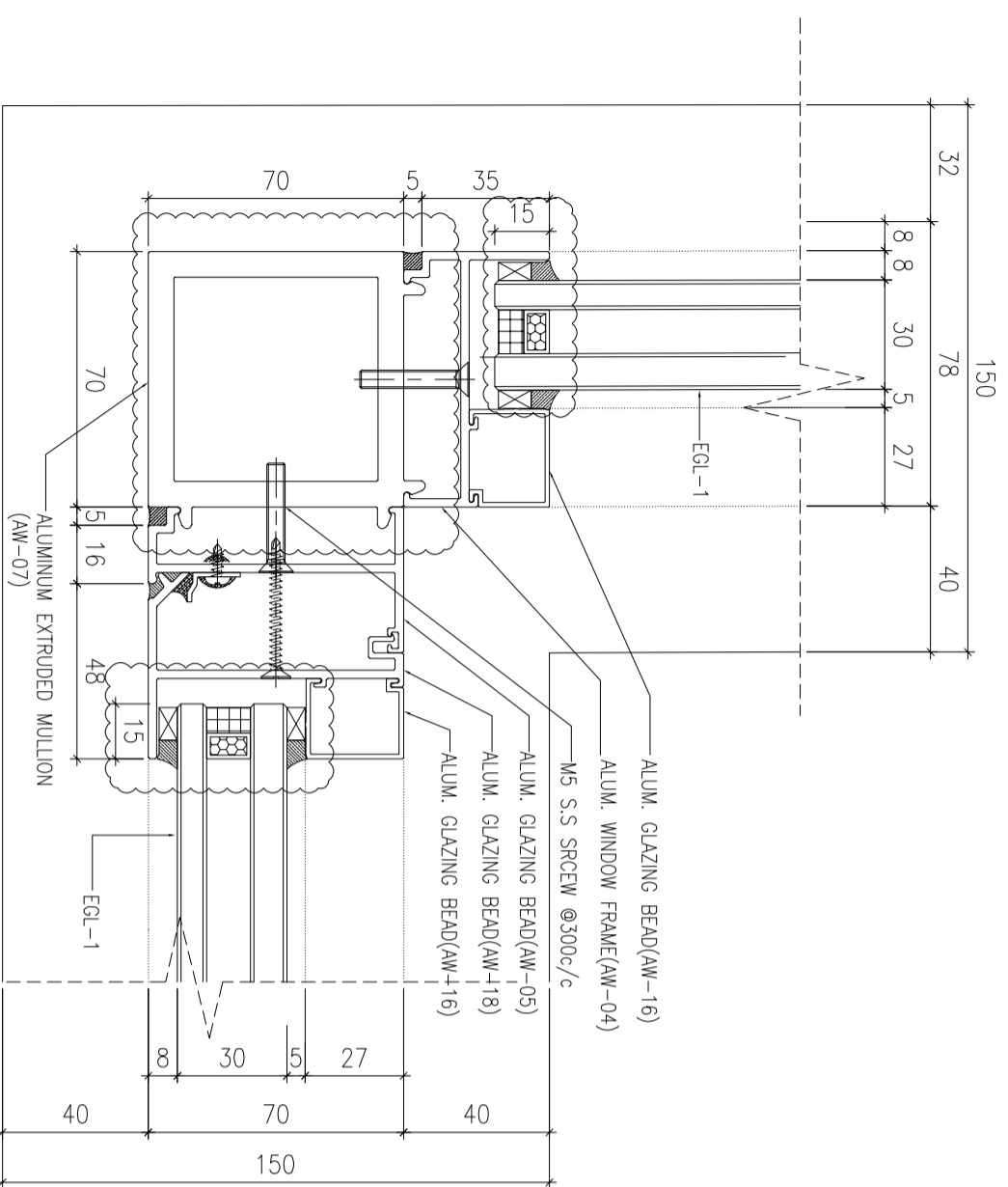

1 HORIZONTAL DETAIL  
SCALE 1:2

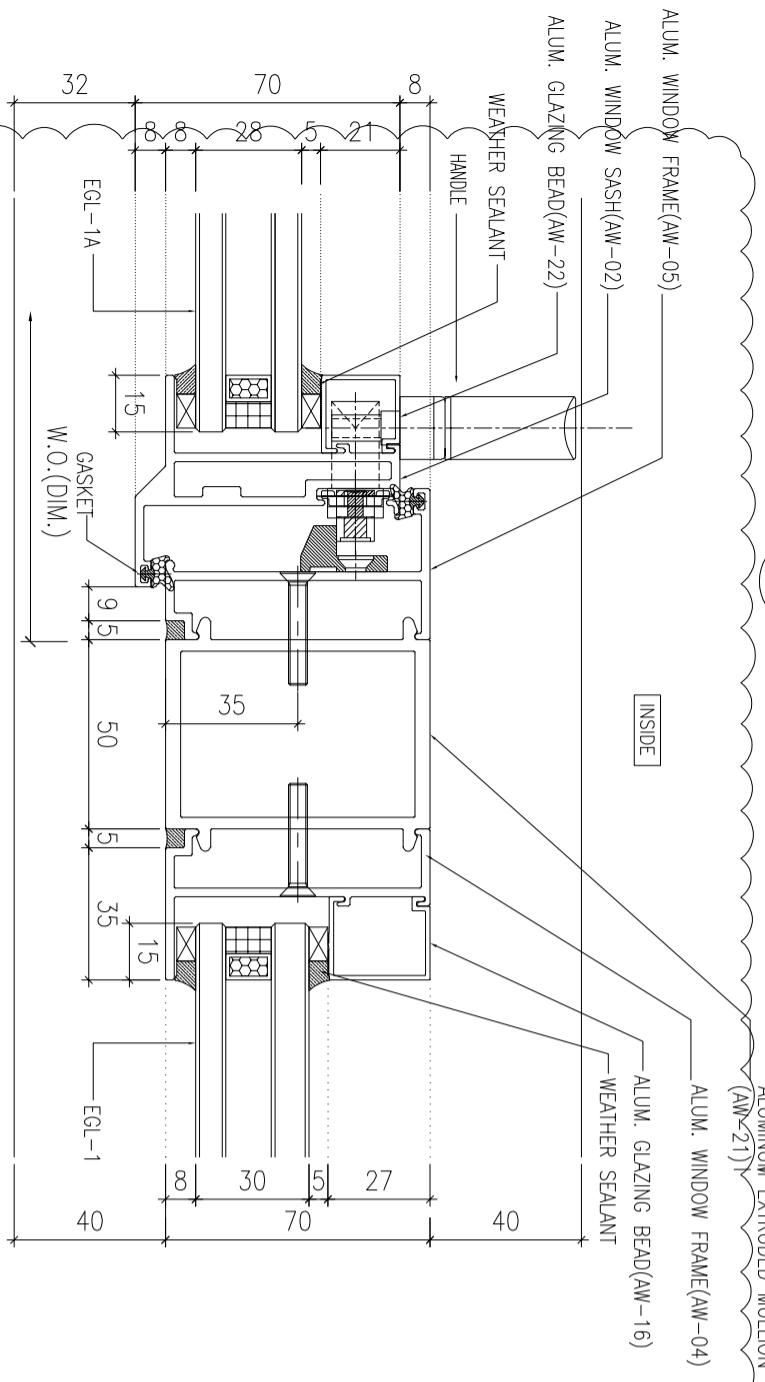

2 HORIZONTAL DETAIL  
SCALE 1:2

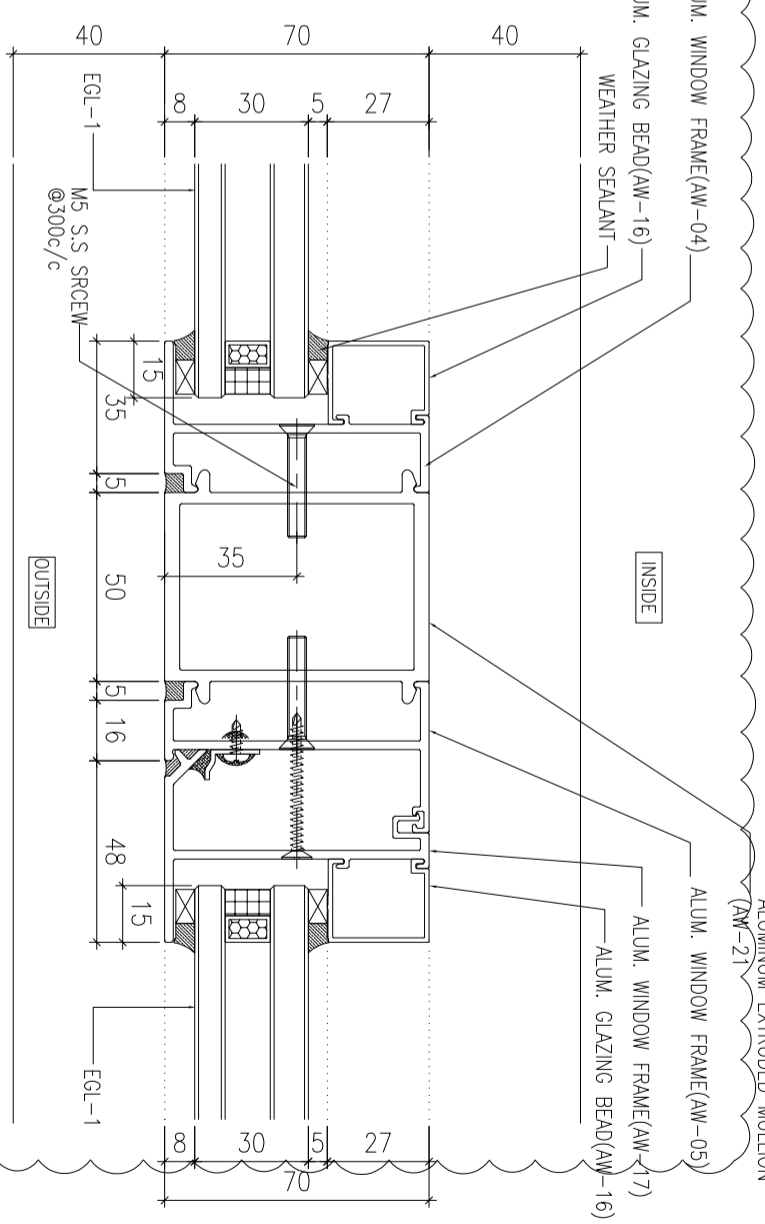

3 HORIZONTAL DETAIL  
SCALE 1:2

B.O. REF :

CLIENT :

**SUN HUNG KAI**  
REAL ESTATE AGENCY LTD.  
42/F SUN HUNG KAI CENTRE, WANCHAI, HONGKONG

ARCHITECT :

**IWK&partners**  
a r c h i t e c t s

MAIN CONTRACTOR :

**怡輝建築有限公司**  
**Yee Fai Building Contractors Ltd.**

STRUCTURAL ENGINEER :

FAÇADE CONSULTANT:  
**ARUP**  
**ALPHA CONSULTING LIMITED**  
Steel Structure & Façade Specialist

NOTE :

1. ALL DIMENSIONS ARE IN mm.
2. ALL ELEVATIONS ARE VIEWED FROM OUTSIDE.
3. ALL DIMENSIONS TO BE VERIFIED ON SITE BEFORE FABRICATION.

LEGEND :

- X1 --- DETAIL MARK NO.
- X001 --- REFER SHEET NO.

1. F.F.L.--FINISHED FLOOR LEVEL
2. S.F.L.--STRUCTURAL FLOOR LEVEL
3. (R) ---REVERSED DETAIL

4. GLASS LEGEND

- EGL-1--9mmHS+12mm AIR GAP+10mmTP THK. I.G.U.
- EGL-2--10mm THK. CLEAR TEMPERED GLASS
- EGL-4--10mm THK. TEMPERED ACID ETCHED GLASS
- EGL-1A--9mmHS+12mm AIR GAP+9mmTP THK. I.G.U.

NO.	DATE	REVISION
D	02/11/2021	REVISION SUBJECT TO ARCH.COMMENT I/IV
C	30/10/2021	REVISION SUBJECT TO ARCH.COMMENT I/IV
B	18/10/2021	REVISION SUBJECT TO ARCH.COMMENT I/IV
A	30/09/2021	REVISION SUBJECT TO ARCH.COMMENT I/IV

JOB NO. : J-856

PROJECT :  
PROPOSED DEVELOPMENT ABOVE  
LIGHT RAIL TIN WING STOP TSWTL  
NO.23,AREA 33,TIN SHUI WAI, N.T.

TITLE :  
TYPICAL DETAILS FOR  
ALUM. WINDOW

DATE : 02-Aug-21 SCALE : 1:40  
DRAWN BY : I/IVN CHECKED BY :

**美特鋁質有限公司**  
**MIDI ALUMINIUM FABRICATOR LTD.**  
Units 6-8, Sunny Industrial Centre, 1/F  
610 Che Kwo Ling Road, Kowloon  
Tel:23489211-4 Fax:(852)27270666  
DWG NO. : J856-SD-PW-DT64 REV. : D

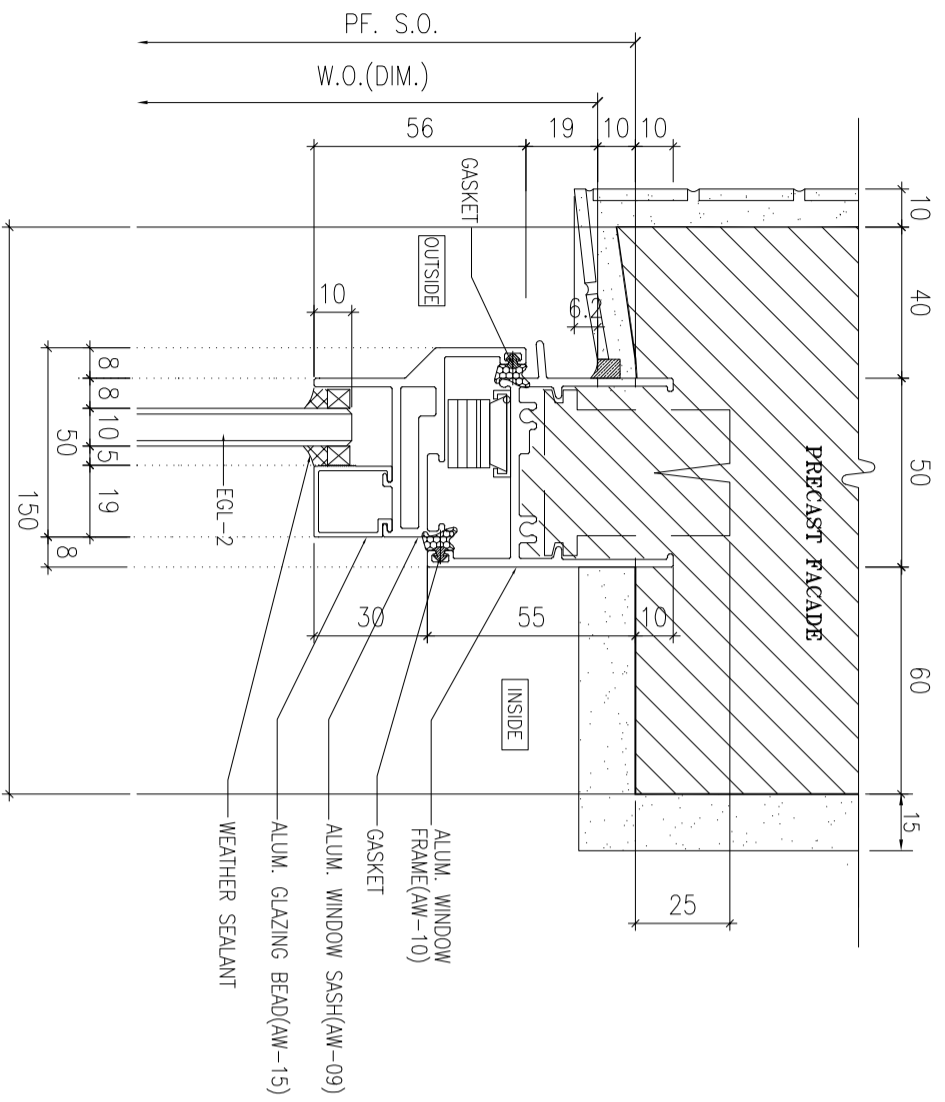

1 HORIZONTAL DETAIL  
SCALE 1:2  
150

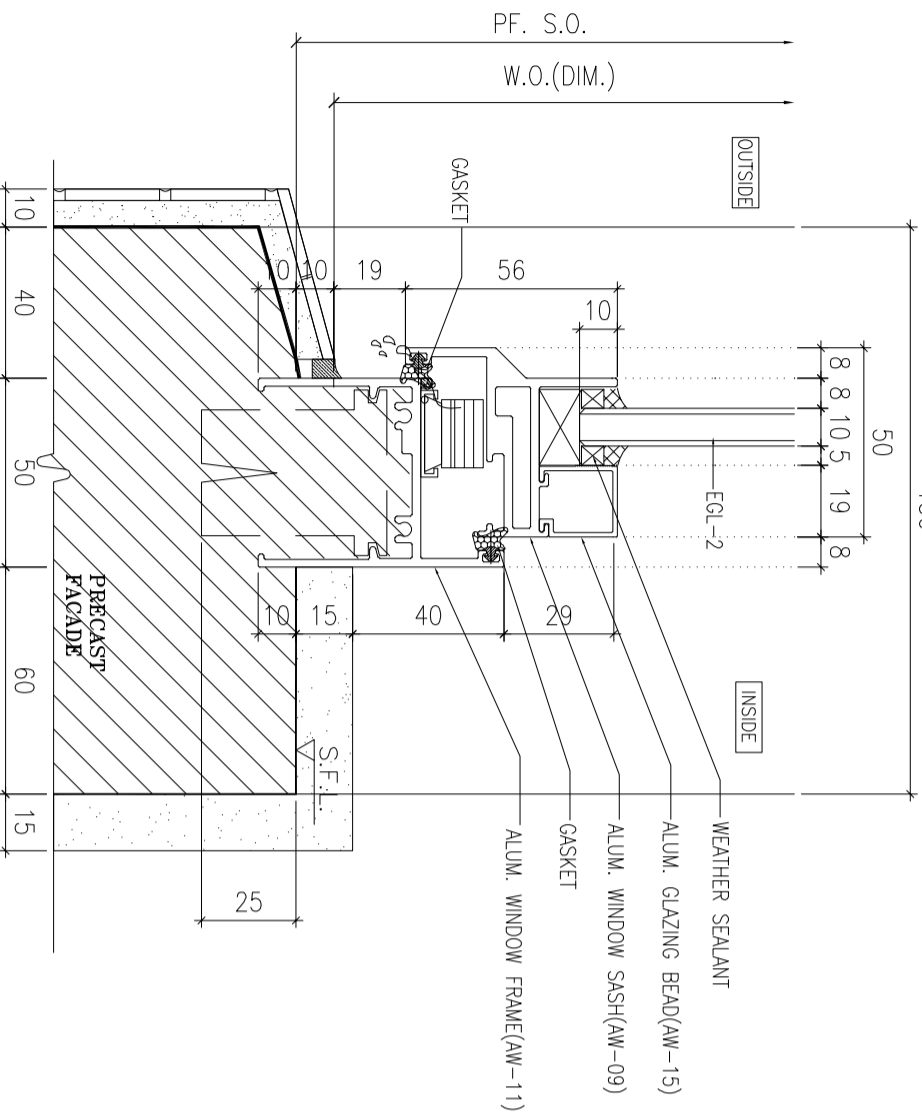

2 HORIZONTAL DETAIL  
SCALE 1:2

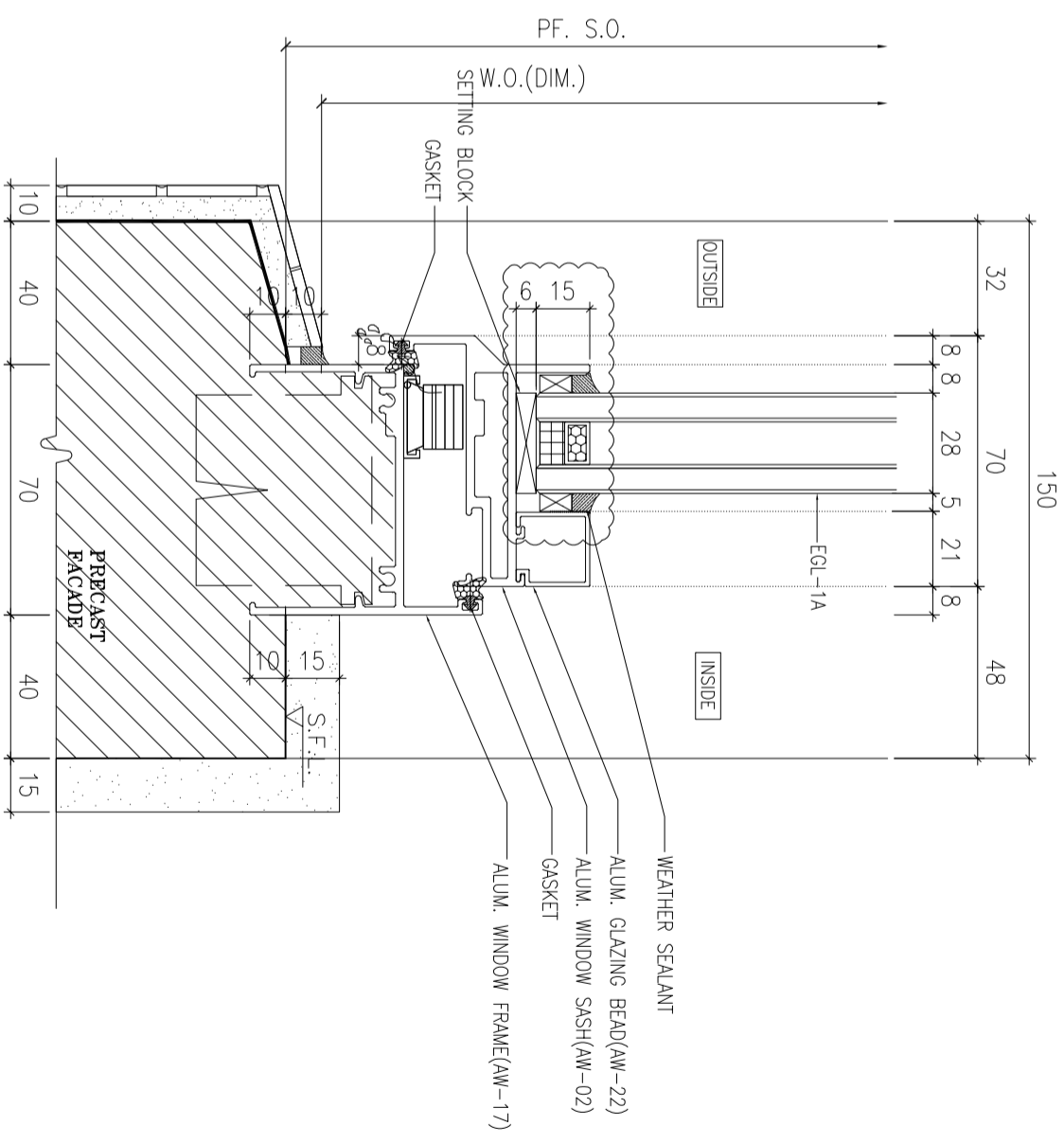

3 HORIZONTAL DETAIL  
SCALE 1:2

B.O. REF :

CLIENT :  
**SUN HUNG KAI**  
REAL ESTATE AGENCY LTD.  
42/F SUN HUNG KAI CENTRE, WANGCHAI, HONGKONG

ARCHITECT :  
**IWK&partners**  
a r c h i t e c t s

MAIN CONTRACTOR :  
**怡輝建築有限公司**  
Yee Fai Building Contractors Ltd.

STRUCTURAL ENGINEER :  
**ARUP**

FAÇADE CONSULTANT:  
**ALPHA CONSULTING LIMITED**  
Steel Structure & Façade Specialist

NOTE :  
1. ALL DIMENSIONS ARE IN mm.  
2. ALL ELEVATIONS ARE VIEWED FROM OUTSIDE.  
3. ALL DIMENSIONS TO BE VERIFIED ON SITE BEFORE FABRICATION.  
LEGEND :

X1 DETAIL MARK NO.  
X001 REFER SHEET NO.  
1. F.F.L.--FINISHED FLOOR LEVEL  
2. S.F.L.--STRUCTURAL FLOOR LEVEL  
3. (R) --REVERSED DETAIL  
4. GLASS LEGEND  
EGL-1--8mmHS+12mm AIR GAP+10mmTP THK. I.G.U.  
EGL-2--10mm THK. CLEAR TEMPERED GLASS  
EGL-4--10mm THK. TEMPERED ACID ETCHED GLASS  
EGL-1A--8mmHS+12mm AIR GAP+8mmTP THK. I.G.U.

NO.	DATE	REVISION SUBJECT TO ARCH/COMMENT	BY
A	30/10/2021	REVISION SUBJECT TO ARCH/COMMENT	WYH
B	02/11/2021	REVISION SUBJECT TO ARCH/COMMENT	WYH

JOB NO. : J-856  
PROJECT : PROPOSED DEVELOPMENT ABOVE LIGHT RAIL TIN WING STOP TSWTL NO.23,AREA 33,TIN SHUI WAI, N.T.  
TITLE : TYPICAL DETAILS FOR ALUM. WINDOW  
DATE : 02-Aug-21 SCALE : 1:40  
DRAWN BY : IYON CHECKED BY :

**美特鋁質有限公司**  
MIDI ALUMINIUM FABRICATOR LTD.  
Units 6-8, Sunny Industrial Centre, 1/F  
610 Che Kwo Ling Road, Kowloon  
Tel:23489211-4 Fax:(852)27272666  
DWG NO. : JB56-SD-PW-DT71 REV. : B

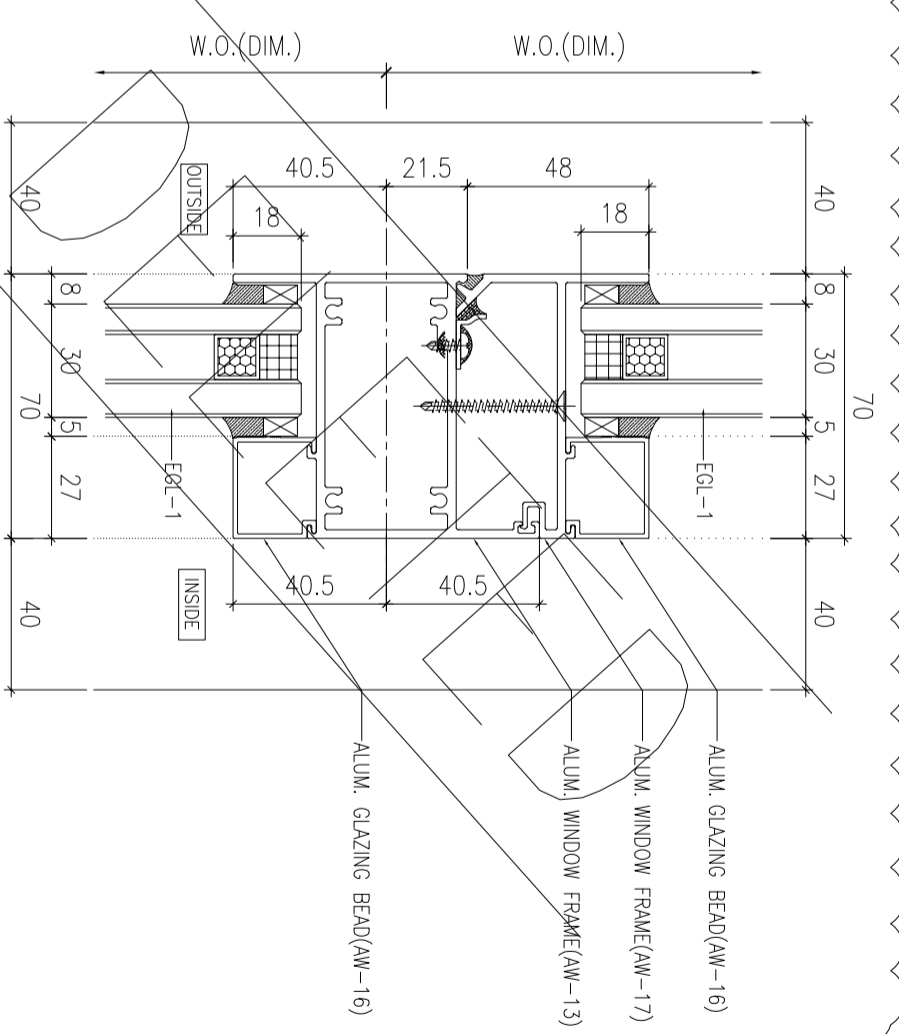
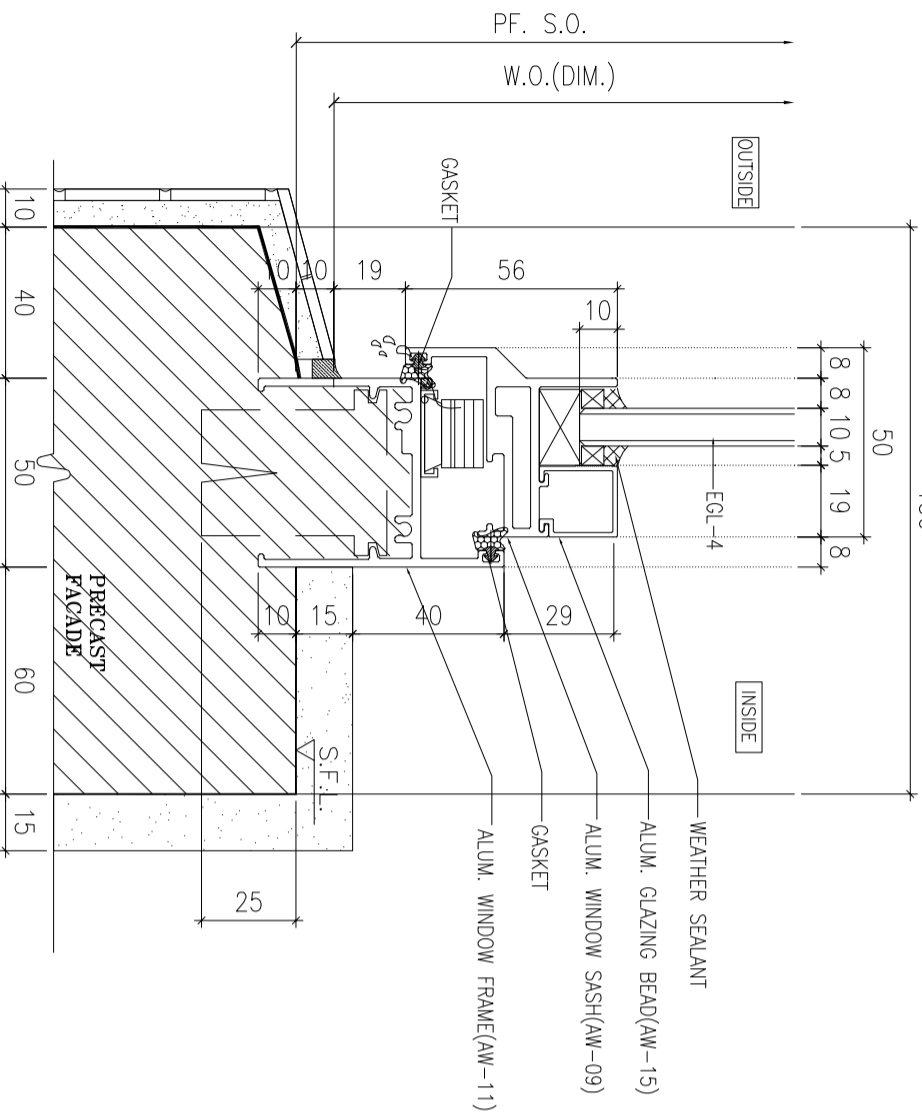
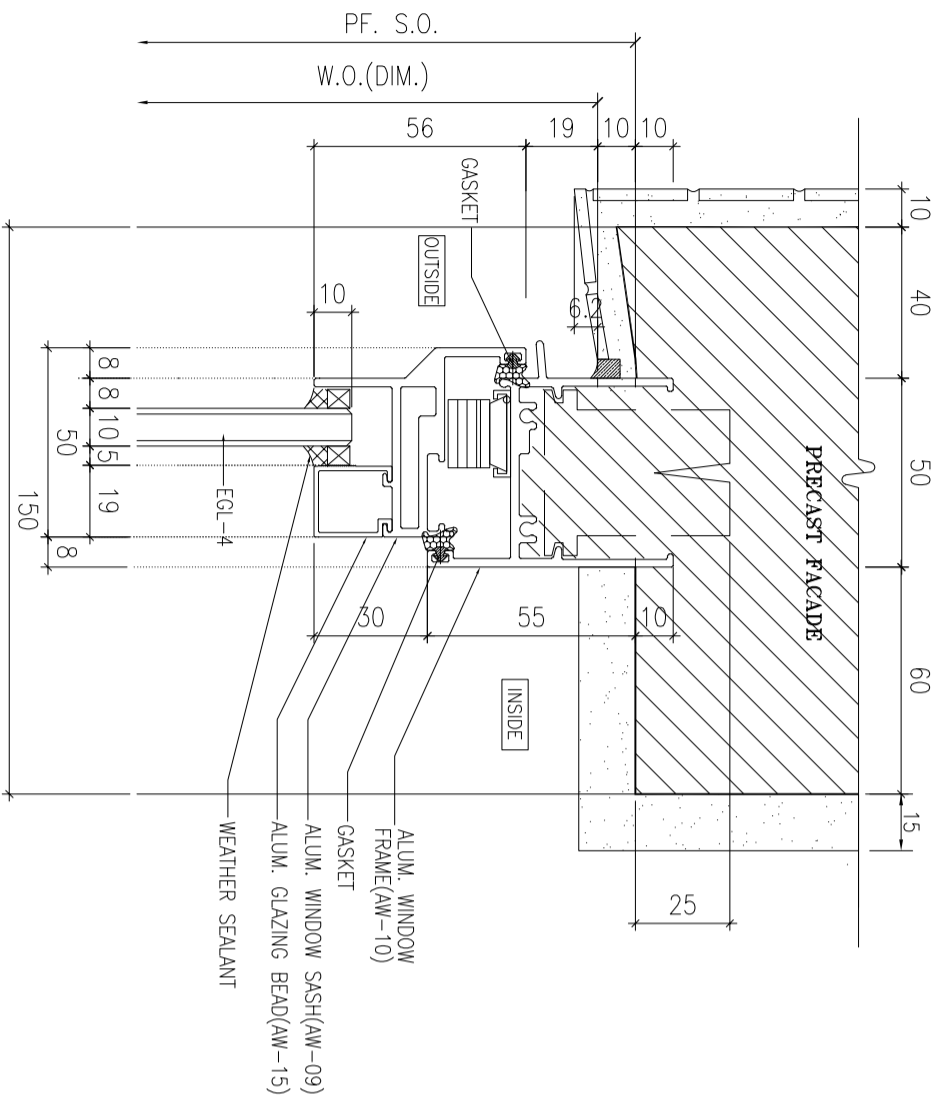

B.O. REF :  
CLIENT : SUN HUNG KAI REAL ESTATE AGENCY LTD.  
42/F SUN HUNG KAI CENTRE, WANGCHAI, HONGKONG  
ARCHITECT : IWK&partners  
MAIN CONTRACTOR : 怡輝建築有限公司 Yee Fai Building Contractors Ltd.  
STRUCTURAL ENGINEER : ARUP  
FAÇADE CONSULTANT : ALPHA CONSULTING LIMITED Steel Structure & Façade Specialist

NOTE :  
1. ALL DIMENSIONS ARE IN mm.  
2. ALL ELEVATIONS ARE VIEWED FROM OUTSIDE.  
3. ALL DIMENSIONS TO BE VERIFIED ON SITE BEFORE FABRICATION.

LEGEND :  
X1 DETAIL MARK NO.  
X001 REFER SHEET NO.

1. F.F.L.--FINISHED FLOOR LEVEL  
2. S.F.L.--STRUCTURAL FLOOR LEVEL  
3. (R) --REVERSED DETAIL  
4. GLASS LEGEND  
EGL-1--8mmHS+12mm AIR GAP+10mmTP THK. I.G.U.  
EGL-2--10mm THK. CLEAR TEMPERED GLASS  
EGL-4--10mm THK. TEMPERED ACID ETCHED GLASS  
EGL-1A--8mmHS+12mm AIR GAP+8mmTP THK. I.G.U.

NO.	DATE	REVISION SUBJECT TO ARCH/COMMENT	BY
B	02/11/2021	REVISION SUBJECT TO ARCH/COMMENT	lvn
A	30/10/2021	REVISION SUBJECT TO ARCH/COMMENT	lvn

JOB NO. : J-856

PROJECT : PROPOSED DEVELOPMENT ABOVE LIGHT RAIL TIN WING STOP TSWTL NO.23,AREA 33,TIN SHUI WAI, N.T.

TITLE : TYPICAL DETAILS FOR ALUM. WINDOW

DATE : 02-Aug-21 SCALE : 1:40

DRAWN BY : lvon CHECKED BY :

Units 6-8, Sunny Industrial Centre, 1/F  
610 Che Kwo Ling Road, Kowloon  
Tel:23489211-4 Fax:85227272666  
DWG NO. : J856-SD-PW-DT71a REV. : B

Yee Fai Building Contractors Ltd.  
SUN HUNG KAI REAL ESTATE AGENCY LTD.  
IWK&partners  
ARUP  
ALPHA CONSULTING LIMITED  
Steel Structure & Façade Specialist

Yee Fai Building Contractors Ltd.  
怡輝建築有限公司  
SUN HUNG KAI REAL ESTATE AGENCY LTD.  
IWK&partners  
ARUP  
ALPHA CONSULTING LIMITED  
Steel Structure & Façade Specialist

Yee Fai Building Contractors Ltd.  
怡輝建築有限公司  
SUN HUNG KAI REAL ESTATE AGENCY LTD.  
IWK&partners  
ARUP  
ALPHA CONSULTING LIMITED  
Steel Structure & Façade Specialist

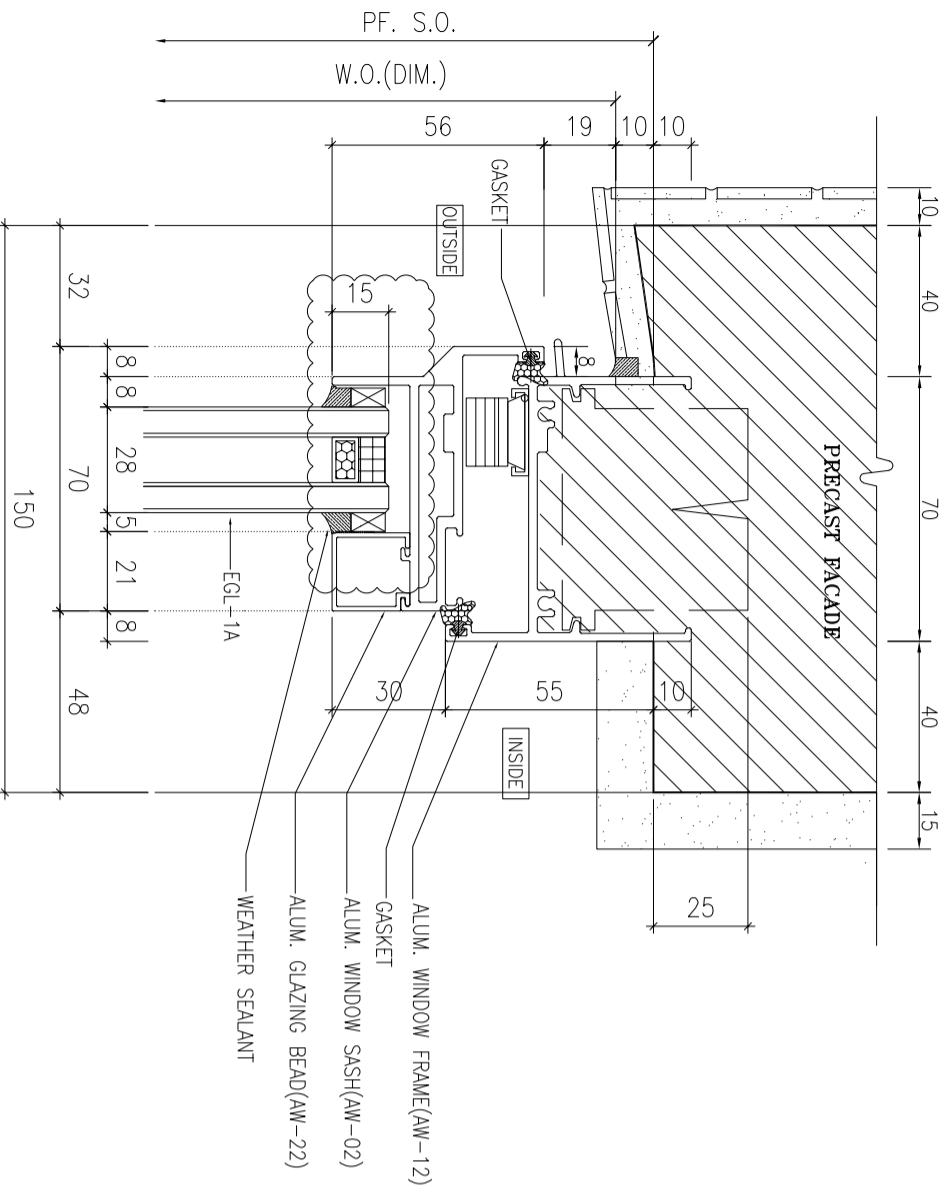

1 HORIZONTAL DETAIL  
SCALE 1:2

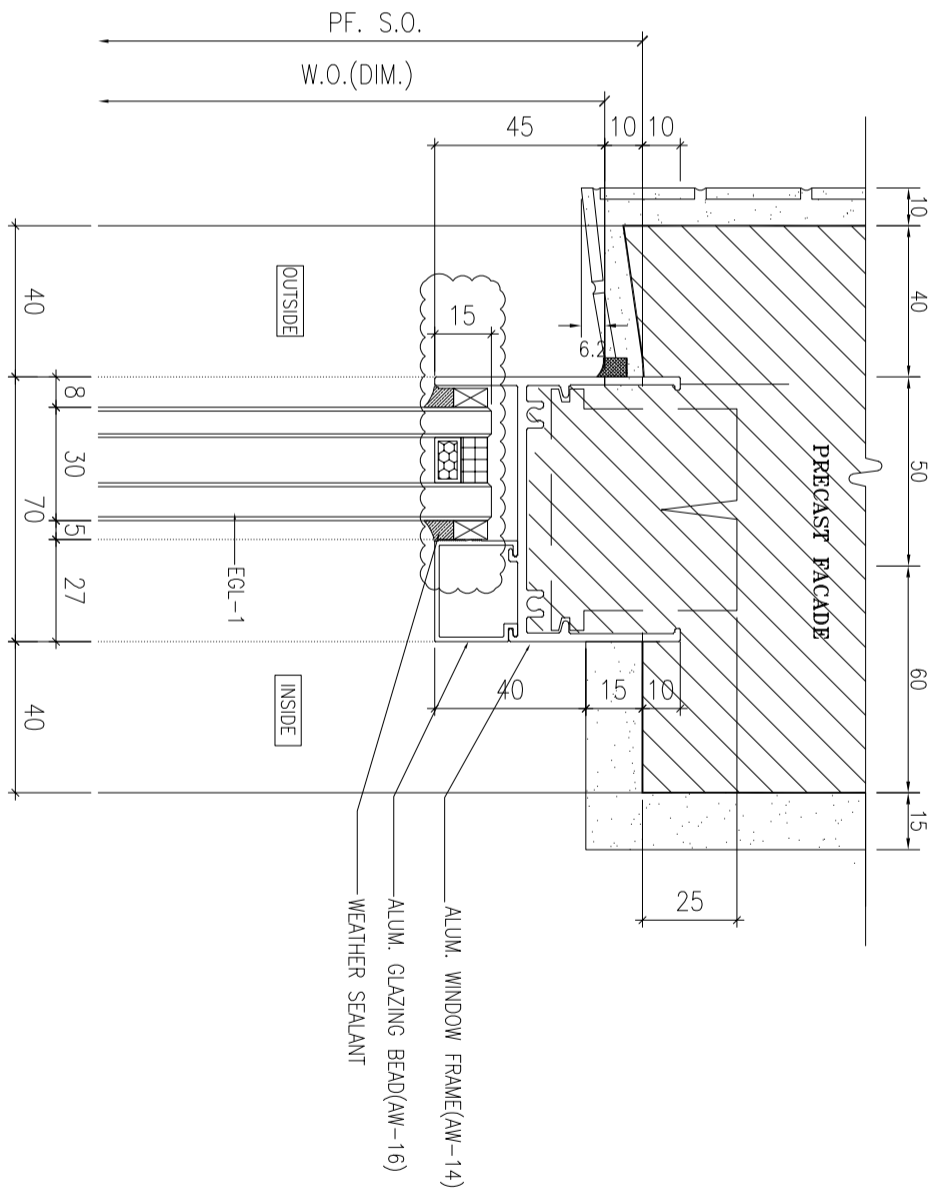

3 HORIZONTAL DETAIL  
SCALE 1:2

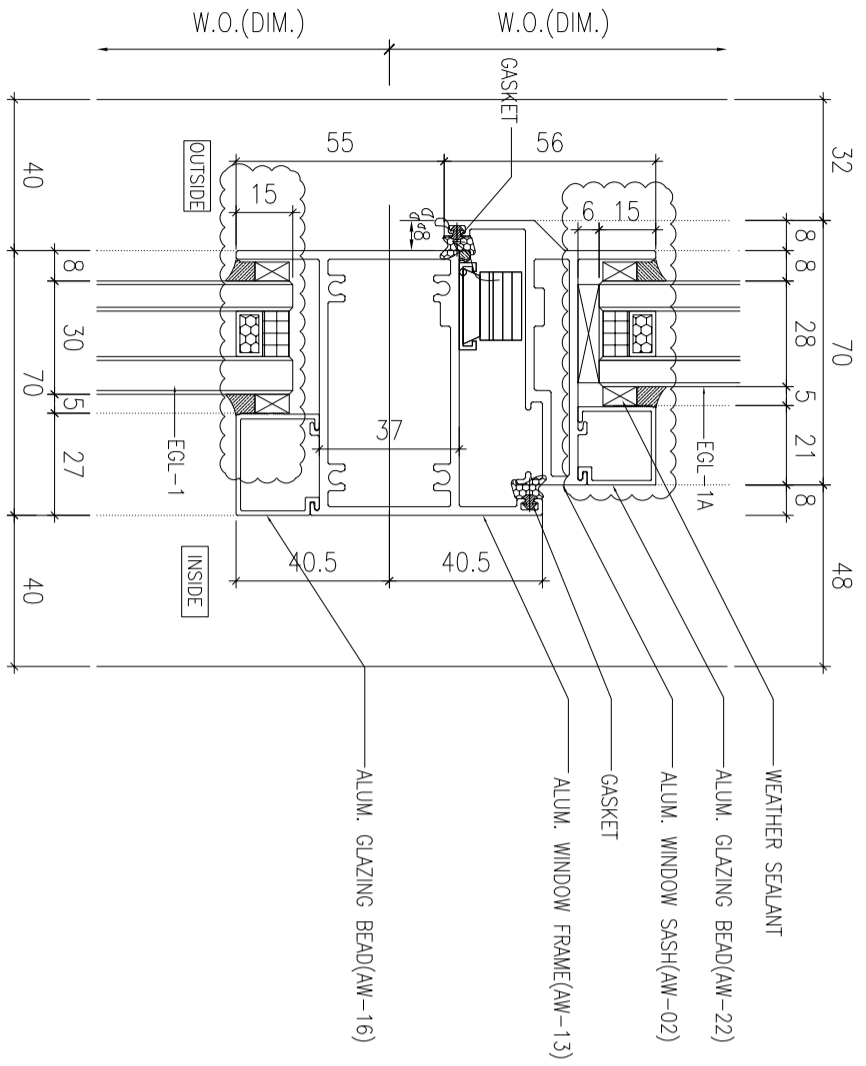

2 HORIZONTAL DETAIL  
SCALE 1:2

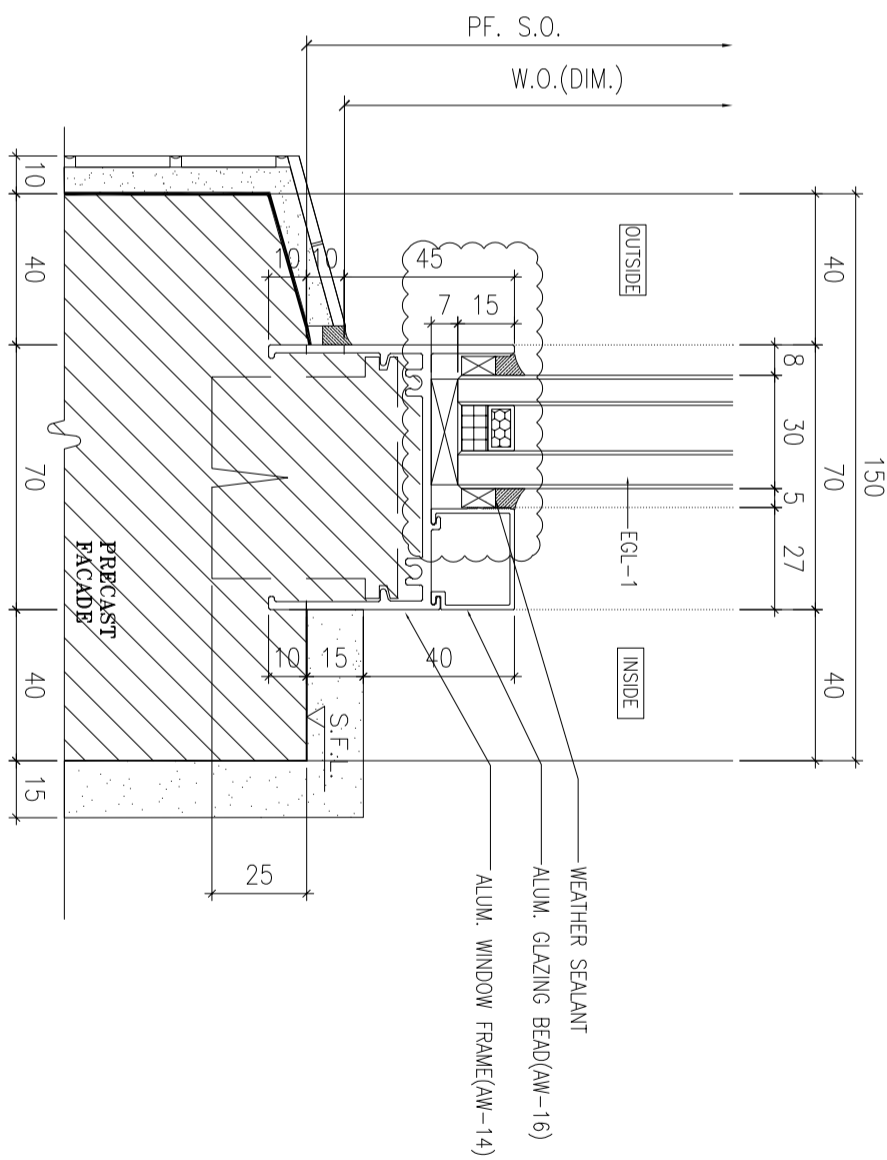

4 HORIZONTAL DETAIL  
SCALE 1:2

B.O. REF :

CLIENT :  
**SUN HUNG KAI**  
REAL ESTATE AGENCY LTD.  
42/F SUN HUNG KAI CENTRE, WANGCHAI, HONGKONG

ARCHITECT :  
**IWK&partners**  
a r c h i t e c t s

MAIN CONTRACTOR :  
**怡輝建築有限公司**  
Yee Fai Building Contractors Ltd.

STRUCTURAL ENGINEER :  
**ARUP**

FAÇADE CONSULTANT:  
**ALPHA CONSULTING LIMITED**  
Steel Structure & Façade Specialist

NOTE :  
1. ALL DIMENSIONS ARE IN mm.  
2. ALL ELEVATIONS ARE VIEWED FROM OUTSIDE.  
3. ALL DIMENSIONS TO BE VERIFIED ON SITE BEFORE FABRICATION.

LEGEND :  
X1 DETAIL MARK NO.  
X001 REFER SHEET NO.

- F.F.L.--FINISHED FLOOR LEVEL
- S.F.L.--STRUCTURAL FLOOR LEVEL
- (R) --REVERSED DETAIL
- GLASS LEGEND  
EQL-1--8mmHS+12mm AIR GAP+10mmTP THK. I.G.U.  
EQL-2--10mm THK. CLEAR TEMPERED GLASS  
EQL-4--10mm THK. TEMPERED ACID ETCHED GLASS  
EQL-1A--8mmHS+12mm AIR GAP+8mmTP THK. I.G.U.

NO.	DATE	REVISION SUBJECT TO ARCH/COMMENT	BY
A	30/10/2021	REVISION SUBJECT TO ARCH/COMMENT	YH
B	02/11/2021	REVISION SUBJECT TO ARCH/COMMENT	YH

JOB NO. : J-856  
PROJECT : PROPOSED DEVELOPMENT ABOVE LIGHT RAIL TIN WING STOP TSWTL NO.23,AREA 33,TIN SHUI WAI, N.T.  
TITLE : TYPICAL DETAILS FOR ALUM. WINDOW

DATE : 02-Aug-21 SCALE : 1:40  
DRAWN BY : Ivorn CHECKED BY :

**美特鋁質有限公司**  
MIDI ALUMINIUM FABRICATOR LTD.  
Units 6-8, Sunray Industrial Centre, 1/F  
610 Che Kwo Ling Road, Kowloon  
Tel:23489211-4 Fax:85227272666  
DWG NO. : JB56-SD-PW-DT72 REV. : B

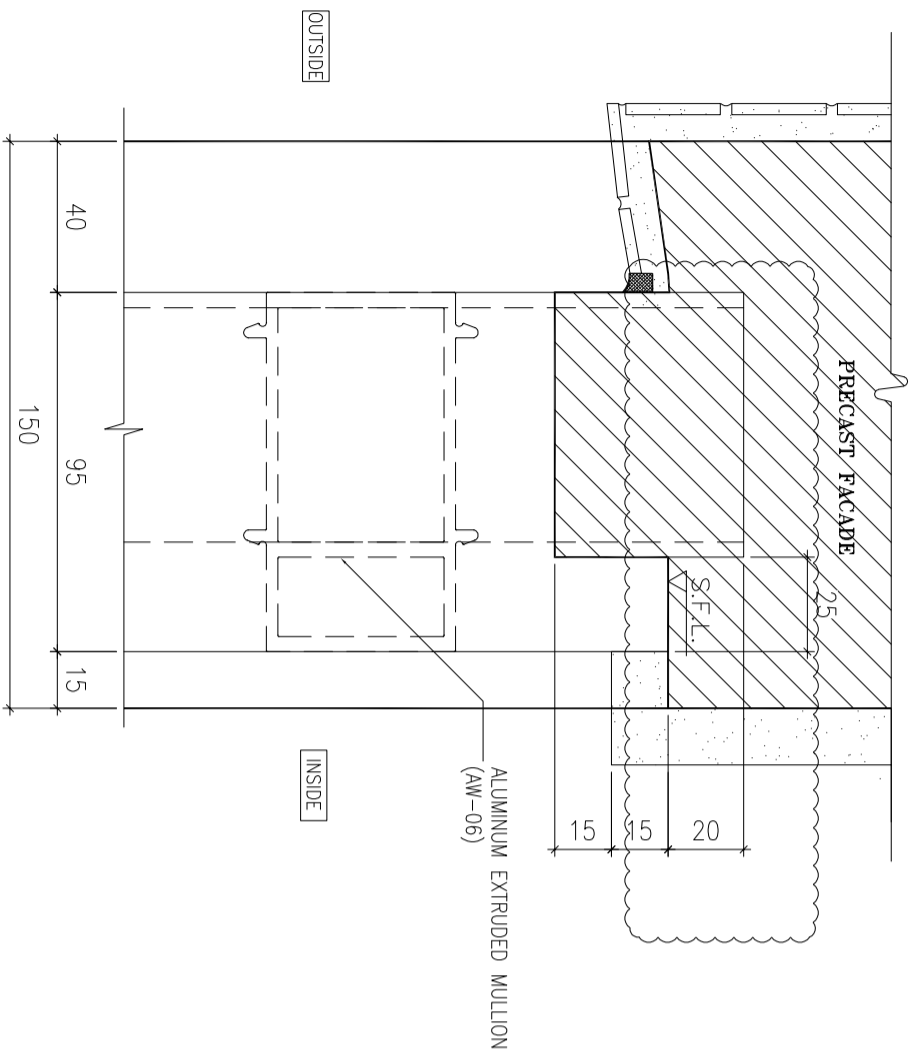

1 HORIZONTAL DETAIL  
SCALE 1:2

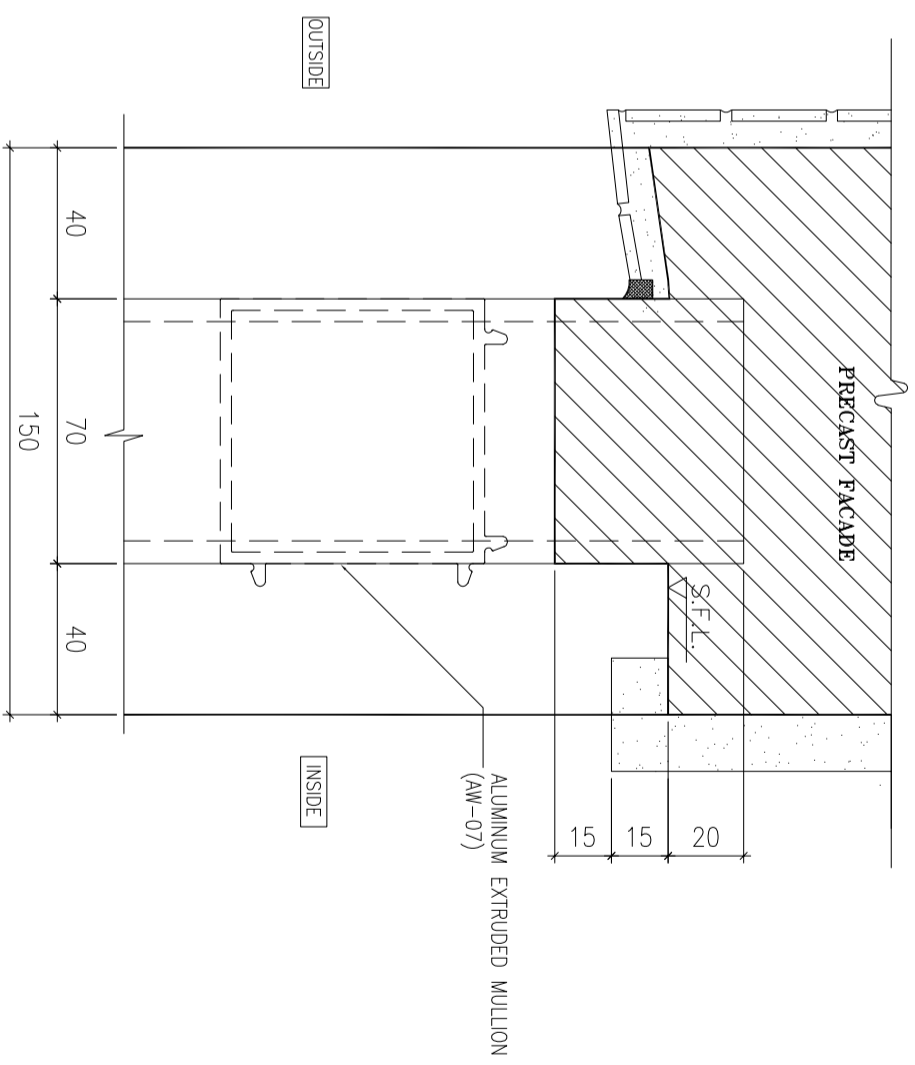

3 HORIZONTAL DETAIL  
SCALE 1:2

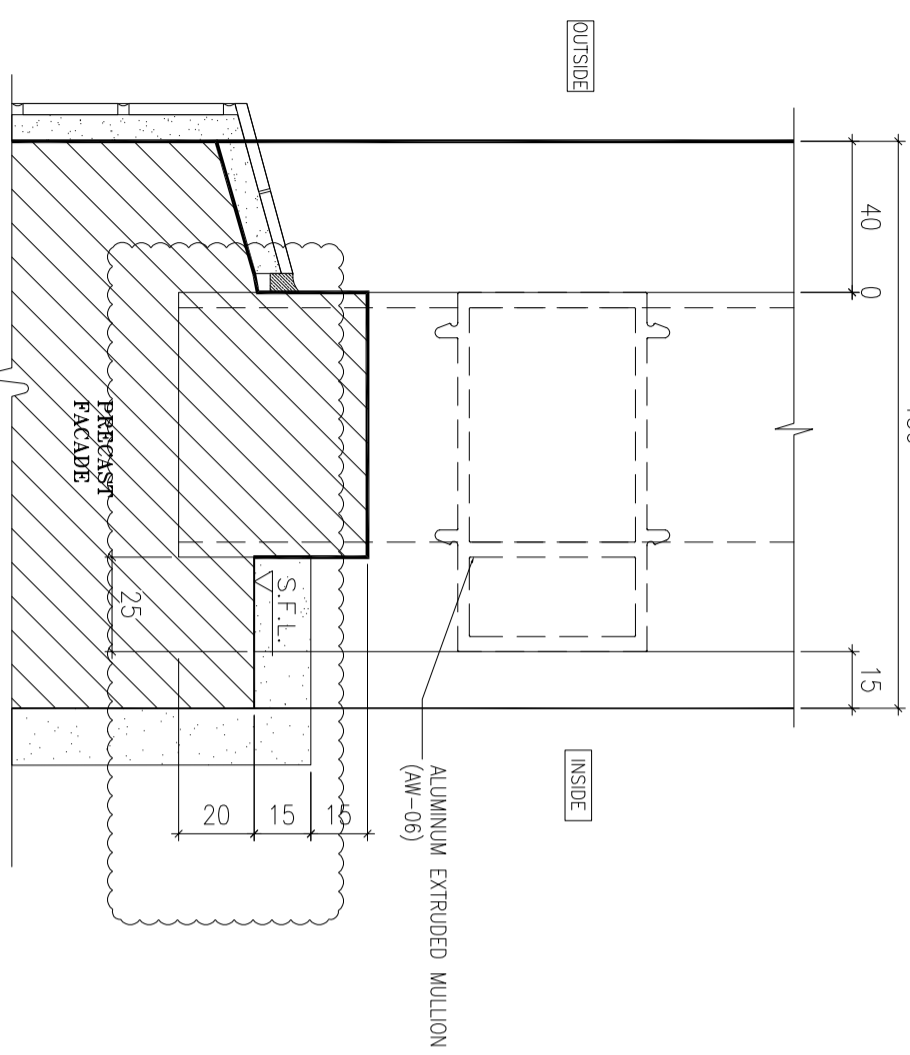

2 HORIZONTAL DETAIL  
SCALE 1:2

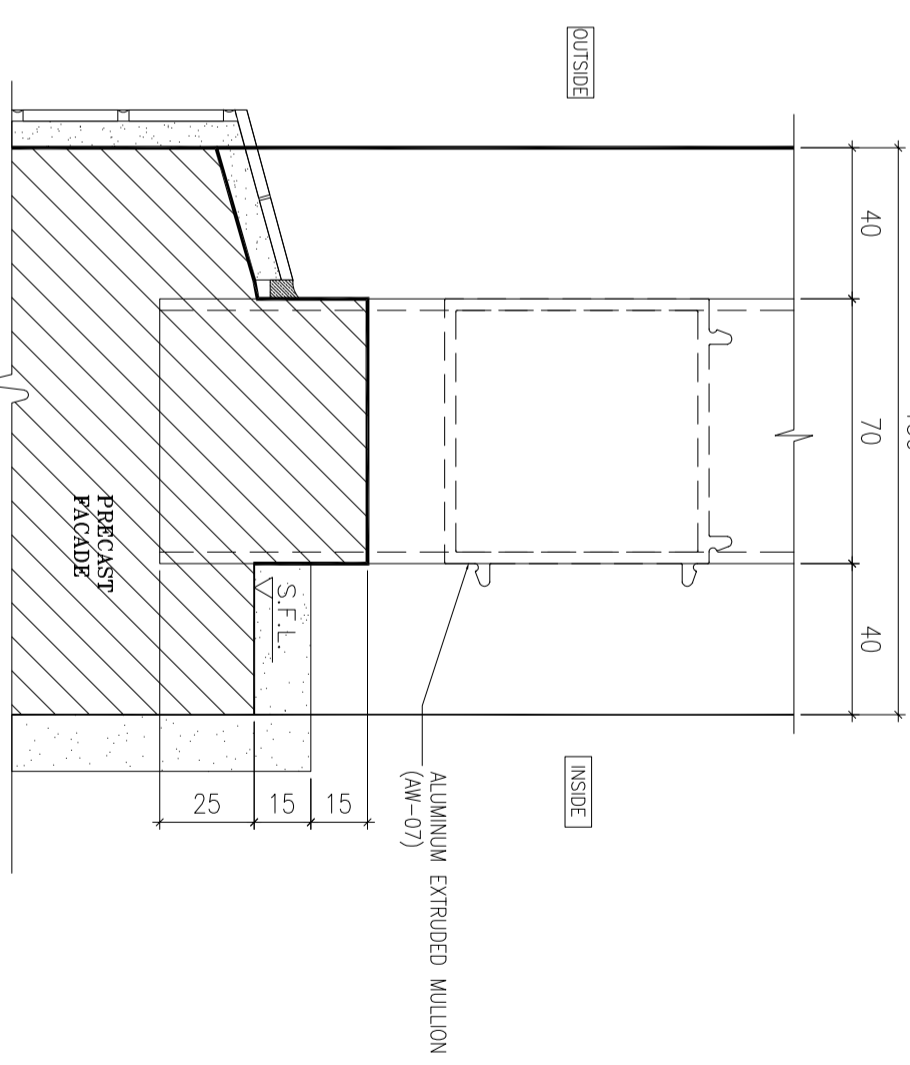

4 HORIZONTAL DETAIL  
SCALE 1:2

B.O. REF :

CLIENT :  
**SUN HUNG KAI**  
REAL ESTATE AGENCY LTD.  
42/F SUN HUNG KAI CENTRE, WANGCHAI, HONGKONG

ARCHITECT :  
**IWK&partners**  
a r c h i t e c t s

MAIN CONTRACTOR :  
**怡輝建築有限公司**  
Yee Fai Building Contractors Ltd.

STRUCTURAL ENGINEER :  
**ARUP**

FAÇADE CONSULTANT:  
**ALPHA CONSULTING LIMITED**  
Steel Structure & Façade Specialist

NOTE :  
1. ALL DIMENSIONS ARE IN mm.  
2. ALL ELEVATIONS ARE VIEWED FROM OUTSIDE.  
3. ALL DIMENSIONS TO BE VERIFIED ON SITE BEFORE FABRICATION.

LEGEND :  
X1 --- DETAIL MARK NO.  
X001 --- REFER SHEET NO.

1. F.F.L. -- FINISHED FLOOR LEVEL  
2. S.F.L. -- STRUCTURAL FLOOR LEVEL  
3. (R) -- REVERSED DETAIL

4. GLASS LEGEND  
EG1-1 -- 6mmHS+12mm AIR GAP+10mmTP THK. I.G.U.  
EG1-2 -- 10mm THK. CLEAR TEMPERED GLASS  
EG1-4 -- 10mm THK. TEMPERED ACID ETCHED GLASS  
EG1-1A -- 8mmHS+12mm AIR GAP+8mmTP THK. I.G.U.

NO.	DATE	REVISION	REVISION SUBJECT TO ARCH/COMMENT	BY
C	02/11/2021	REVISION SUBJECT TO ARCH/COMMENT		WYH
B	30/09/2021	REVISION SUBJECT TO ARCH/COMMENT		WYH
A	30/09/2021	REVISION SUBJECT TO ARCH/COMMENT		WYH

JOB NO. : J-856  
PROJECT : PROPOSED DEVELOPMENT ABOVE LIGHT RAIL TIN WING STOP TSWTL NO.23, AREA 33, TIN SHUI WAI, N.T.  
TITLE : TYPICAL DETAILS FOR ALUM. WINDOW

DATE : 02-Aug-21 SCALE : 1:40  
DRAWN BY : IYVH CHECKED BY :

**美特鋁質有限公司**  
MIDI ALUMINIUM FABRICATOR LTD.  
Units 6-8, Sunny Industrial Centre, 1/F  
610 Che Kwo Ling Road, Kowloon  
Tel:23489211-4 Fax:8522727666  
DWG NO. : J856-SD-PW-DT73 REV. : C

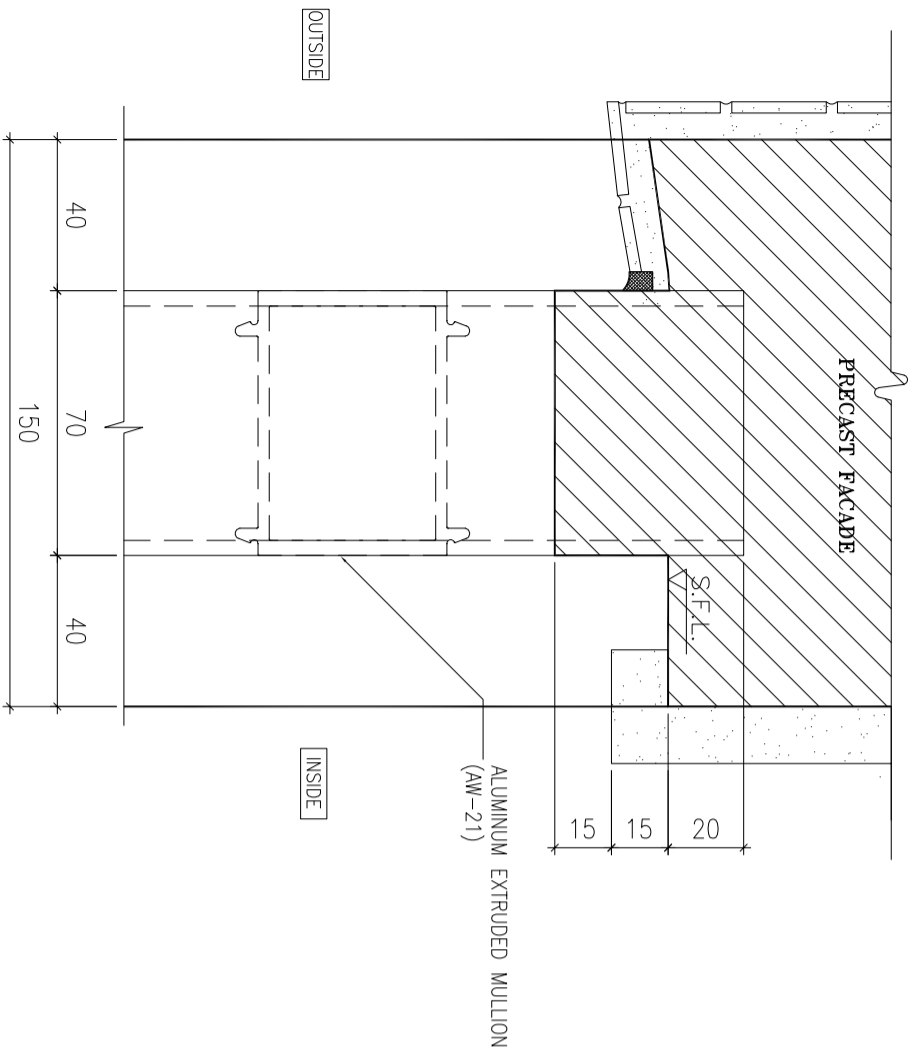

**1** HORIZONTAL DETAIL  
SCALE 1:2

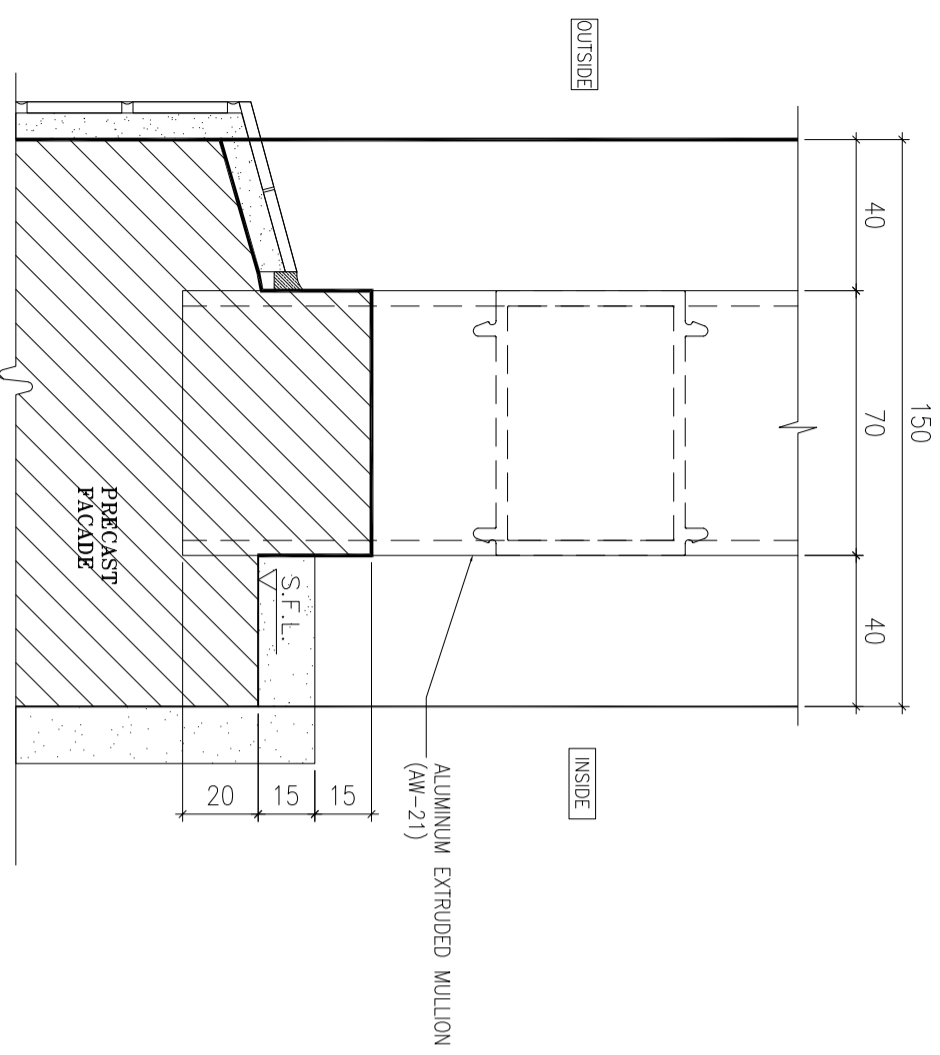

**2** HORIZONTAL DETAIL  
SCALE 1:2

B.O. REF :

CLIENT :

**SUN HUNG KAI**  
REAL ESTATE AGENCY LTD.  
42/F SUN HUNG KAI CENTRE, WANGCHAI, HONGKONG

ARCHITECT :

**lwk&partners**  
a r c h i t e c t s

MAIN CONTRACTOR :

**怡輝建築有限公司**  
**Yee Fai Building Contractors Ltd.**

STRUCTURAL ENGINEER :

**ARUP**  
FAÇADE CONSULTANT:

**ALPHA CONSULTING LIMITED**  
Steel Structure & Façade Specialist

NOTE :

1. ALL DIMENSIONS ARE IN mm.
2. ALL ELEVATIONS ARE VIEWED FROM OUTSIDE.
3. ALL DIMENSIONS TO BE VERIFIED ON SITE BEFORE FABRICATION.

LEGEND :

X1 — DETAIL MARK NO.  
X001 — REFER SHEET NO.

1. F.F.L. -- FINISHED FLOOR LEVEL
2. S.F.L. -- STRUCTURAL FLOOR LEVEL
3. (R) -- REVERSED DETAIL

4. GLASS LEGEND

- EGL-1 -- 8mmHS+12mm AIR GAP+10mmTP THK. I.G.U.  
EGL-2 -- 10mm THK. CLEAR TEMPERED GLASS  
EGL-4 -- 10mm THK. TEMPERED ACID ETCHED GLASS  
EGL-1A -- 8mmHS+12mm AIR GAP+8mmTP THK. I.G.U.

NO.	DATE	REVISION	BY

JOB NO. : J-856

PROJECT :  
PROPOSED DEVELOPMENT ABOVE  
LIGHT RAIL TIN WING STOP TSWTL  
NO.23, AREA 33, TIN SHUI WAI, N.T.

TITLE :  
TYPICAL DETAILS FOR  
ALUM. WINDOW

DATE : 02-Aug-21 SCALE : 1:40

DRAWN BY : Ivorn CHECKED BY :

**美特鋁質有限公司**  
MIDI ALUMINIUM FABRICATOR LTD.  
Units 6-8, Sunny Industrial Centre, 1/F  
610 Che Kwo Ling Road, Kowloon  
Tel:23489211-4 Fax:8522727666

DWG NO. : JB56-SD-PW-DT73a REV. : -

B.O. REF :

CLIENT :

**SUN HUNG KAI**  
REAL ESTATE AGENCY LTD.  
42/F SUN HUNG KAI CENTRE, WANGCHAI, HONGKONG

ARCHITECT :

**lwk&partners**  
a r c h i t e c t s

MAIN CONTRACTOR :

**怡輝建築有限公司**  
Yee Fai Building Contractors Ltd.

STRUCTURAL ENGINEER :

**ARUP**

FAÇADE CONSULTANT:

**ALPHA CONSULTING LIMITED**  
Steel Structure & Façade Specialist

NOTE :

1. ALL DIMENSIONS ARE IN mm.
2. ALL ELEVATIONS ARE VIEWED FROM OUTSIDE.
3. ALL DIMENSIONS TO BE VERIFIED ON SITE BEFORE FABRICATION.

LEGEND :

X1 --- DETAIL MARK NO.  
X001 --- REFER SHEET NO.

1. F.F.L. --- FINISHED FLOOR LEVEL
2. S.F.L. --- STRUCTURAL FLOOR LEVEL
3. (R) --- REVERSED DETAIL

4. GLASS LEGEND

- EQ1-1 --- 6mmHS+12mm AIR GAP+10mmTP THK. I.G.U.
- EQ1-2 --- 10mm THK. CLEAR TEMPERED GLASS
- EQ1-4 --- 10mm THK. TEMPERED ACID ETCHED GLASS
- EQ1-1A --- 6mmHS+12mm AIR GAP+8mmTP THK. I.G.U.

NO.	DATE	REVISION	BY

JOB NO. : J-856

PROJECT :

PROPOSED DEVELOPMENT ABOVE  
LIGHT RAIL TIN WING STOP TSWTL  
NO.23,AREA 33,TIN SHUI WAI, N.T.

TITLE :

ALUM. WINDOW SECTION  
TYPICAL LOCK & HINGES DETAIL

DATE : 02-Aug-21 SCALE : 1:40

DRAWN BY : Ivorn CHECKED BY :

**美特鋁質有限公司**  
MIDI ALUMINIUM FABRICATOR LTD.  
Units 6-8, Sunny Industrial Centre, 1/F  
610 Che Kwo Ling Road, Kowloon  
Tel:23489211-4 Fax:8522727666

DWG NO. : JB56-SD-PW-DT74 REV. : -

# 70窗

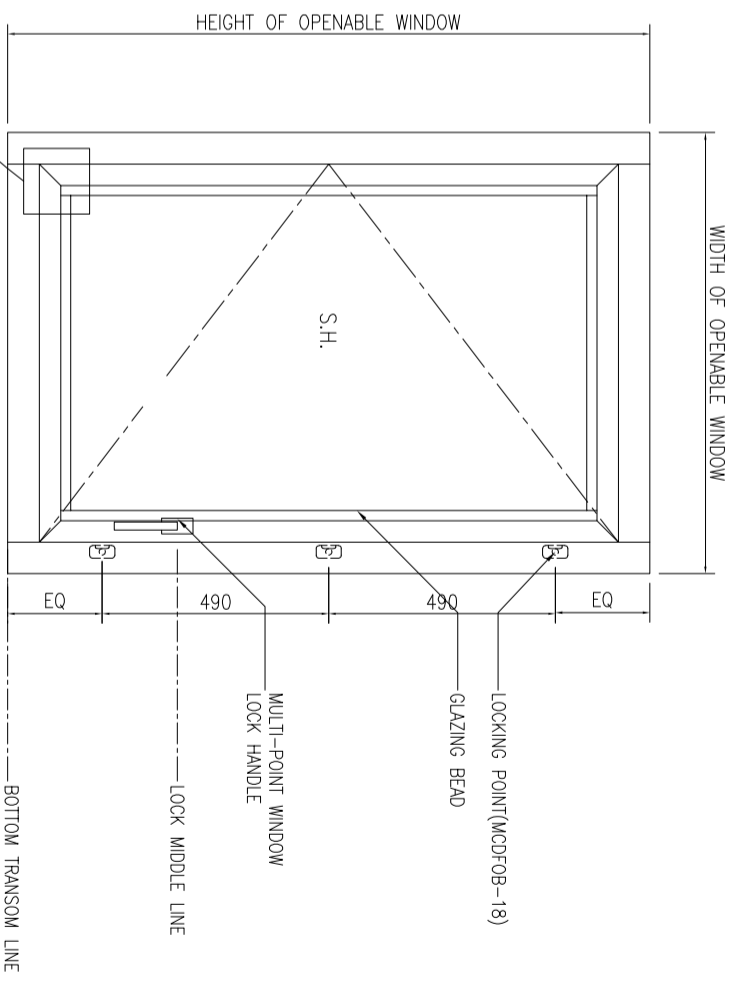
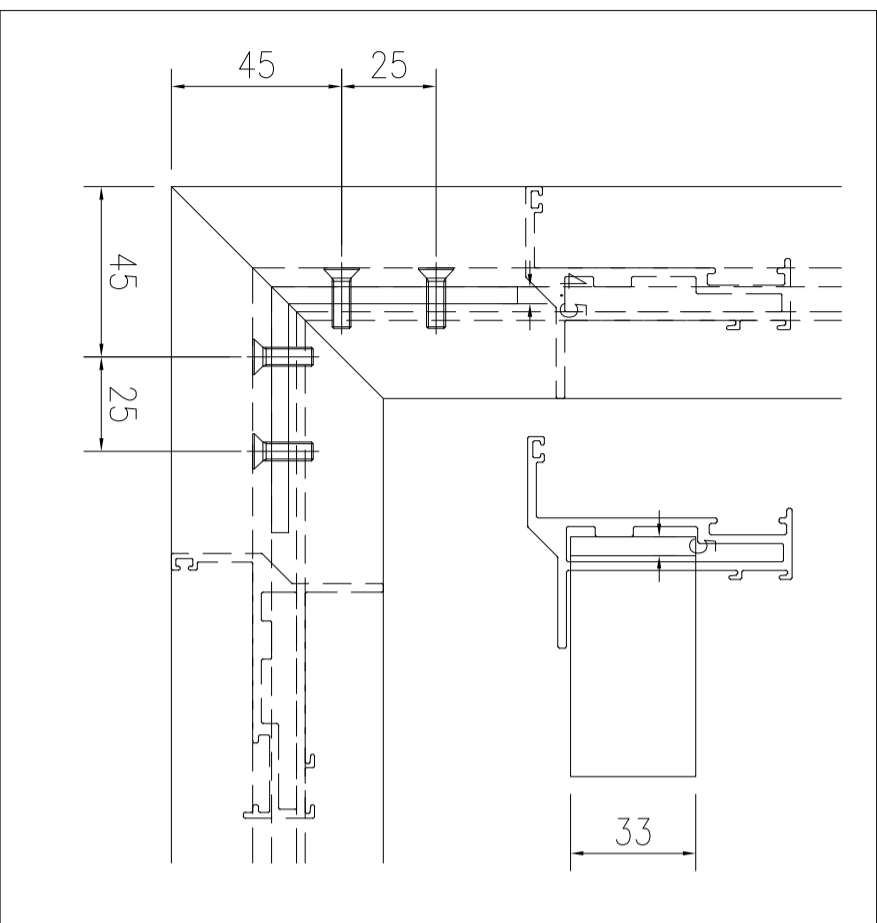

01 TYPICAL SECTION

S.F.L.

B.O. REF :

CLIENT :

**SUN HUNG KAI**  
REAL ESTATE AGENCY LTD.  
42/F SUN HUNG KAI CENTRE, WANGCHAI, HONGKONG

ARCHITECT :

**lwk&partners**  
a r c h i t e c t s

MAIN CONTRACTOR :

**怡輝建築有限公司**  
Yee Fai Building Contractors Ltd.

STRUCTURAL ENGINEER :

**ARUP**

FAÇADE CONSULTANT:

**ALPHA CONSULTING LIMITED**  
Steel Structure & Façade Specialist

NOTE :

1. ALL DIMENSIONS ARE IN mm.
2. ALL ELEVATIONS ARE VIEWED FROM OUTSIDE.
3. ALL DIMENSIONS TO BE VERIFIED ON SITE BEFORE FABRICATION.

LEGEND :

X1 --- DETAIL MARK NO.  
X001 --- REFER SHEET NO.

1. F.F.L. --- FINISHED FLOOR LEVEL
2. S.F.L. --- STRUCTURAL FLOOR LEVEL
3. (R) --- REVERSED DETAIL

4. GLASS LEGEND

- EQ1-1 --- 6mmHS+12mm AIR GAP+10mmTP THK. I.G.U.  
EQ1-2 --- 10mm THK. CLEAR TEMPERED GLASS  
EQ1-4 --- 10mm THK. TEMPERED ACID ETCHED GLASS  
EQ1-1A --- 6mmHS+12mm AIR GAP+8mmTP THK. I.G.U.

NO.	DATE	REVISION	BY

JOB NO. : J-856

PROJECT :

PROPOSED DEVELOPMENT ABOVE  
LIGHT RAIL TIN WING STOP TSWTL  
NO.23,AREA 33,TIN SHUI WAI, N.T.

TITLE :

ALUM. WINDOW SECTION  
TYPICAL LOCK & HINGES DETAIL

DATE : 02-Aug-21 SCALE : 1:40

DRAWN BY : Ivorn CHECKED BY :

**美特鋁質有限公司**  
MIDI ALUMINIUM FABRICATOR LTD.  
Units 6-8, Sunny Industrial Centre, 1/F  
610 Che Kwo Ling Road, Kowloon  
Tel:23489211-4 Fax:8522727666

DWG NO. : JB56-SD-PW-DT74d REV. : -

# 50窗

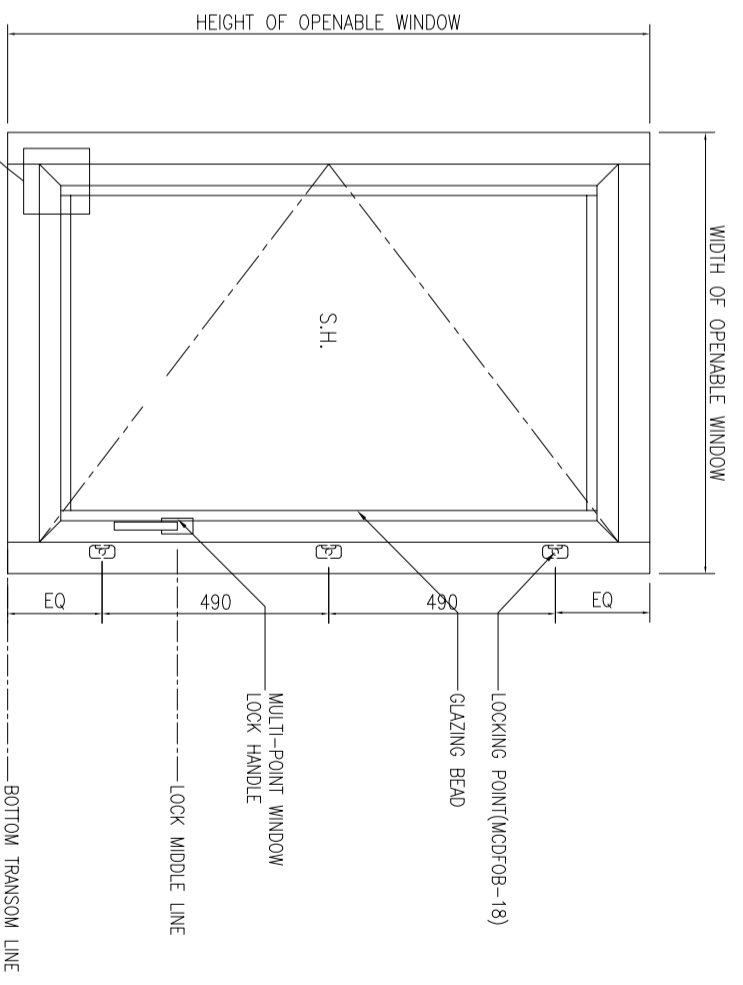
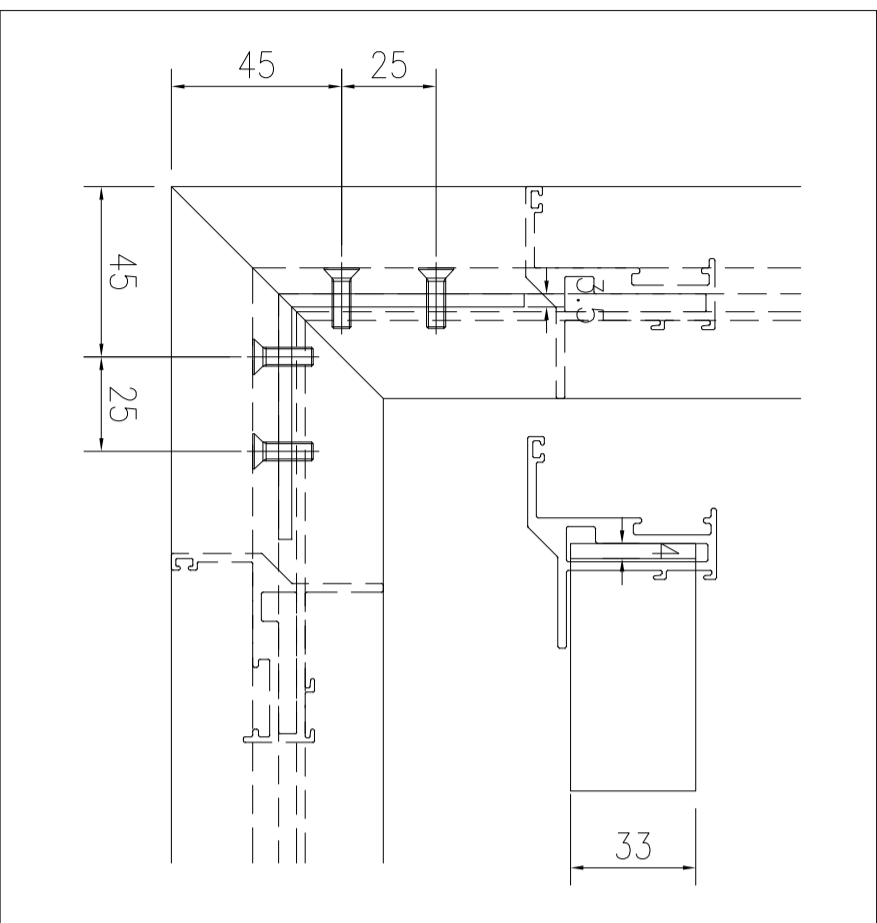

01 TYPICAL SECTION

S.F.L.

B.O. REF :

CLIENT :

**SUN HUNG KAI**  
REAL ESTATE AGENCY LTD.  
42/F SUN HUNG KAI CENTRE, WANGCHAI, HONGKONG

ARCHITECT :

**IWK&partners**  
a r c h i t e c t s

MAIN CONTRACTOR :

**怡輝建築有限公司**  
Yee Fai Building Contractors Ltd.

STRUCTURAL ENGINEER :

**ARUP**

FAÇADE CONSULTANT:

**ALPHA CONSULTING LIMITED**  
Steel Structure & Façade Specialist

NOTE :

1. ALL DIMENSIONS ARE IN mm.
2. ALL ELEVATIONS ARE VIEWED FROM OUTSIDE.
3. ALL DIMENSIONS TO BE VERIFIED ON SITE BEFORE FABRICATION.

LEGEND :

X1 --- DETAIL MARK NO.  
X001 --- REFER SHEET NO.

1. F.F.L. --- FINISHED FLOOR LEVEL
2. S.F.L. --- STRUCTURAL FLOOR LEVEL
3. (R) --- REVERSED DETAIL

4. GLASS LEGEND

- EQ1-1 --- 6mmHS+12mm AIR GAP+10mmTP THK. I.G.U.  
EQ1-2 --- 10mm THK. CLEAR TEMPERED GLASS  
EQ1-4 --- 10mm THK. TEMPERED ACID ETCHED GLASS  
EQ1-1A --- 8mmHS+12mm AIR GAP+8mmTP THK. I.G.U.

NO.	DATE	REVISION	BY

JOB NO. : J-856

PROJECT : PROPOSED DEVELOPMENT ABOVE LIGHT RAIL TIN WING STOP TSWTL NO.23, AREA 33, TIN SHUI WAI, N.T.

TITLE : G.M.S FIXING LUG TYPICAL DETAIL FOR ALUM. WINDOW

DATE : 02-Aug-21 SCALE : 1:60

DRAWN BY : ivon CHECKED BY :

**美特鋁質有限公司**  
MIDI ALUMINIUM FABRICATOR LTD.  
Units 6-8, Sunny Industrial Centre, 1/F  
610 Che Kwo Ling Road, Kowloon  
Tel: 23489211-4 Fax: (852) 27272666

DWG NO. : J856-SD-PW-D175 REV. : -

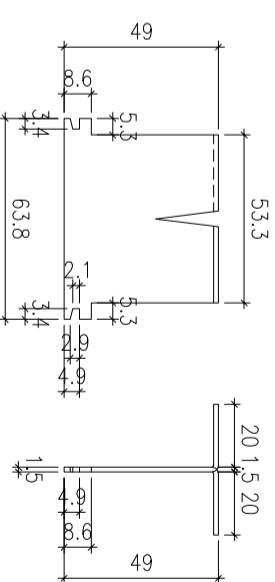
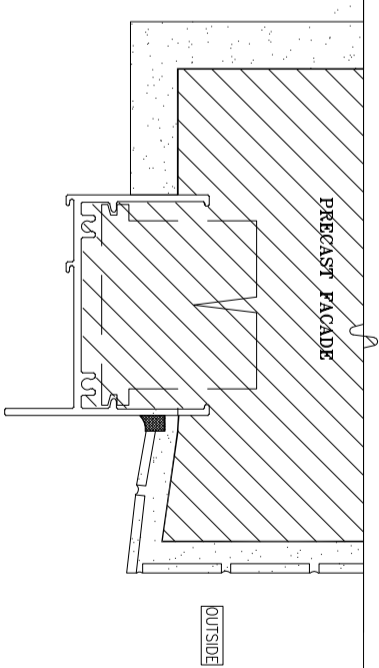

**1** HORIZONTAL DETAIL  
SCALE 1:2

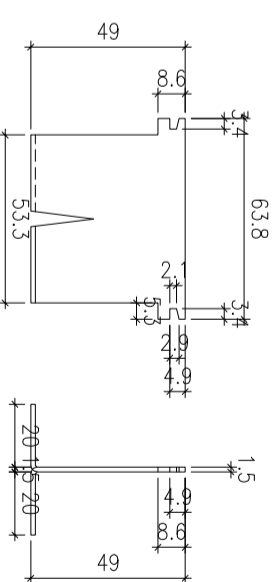

**2** HORIZONTAL DETAIL  
SCALE 1:2

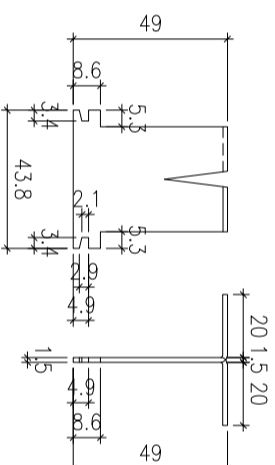
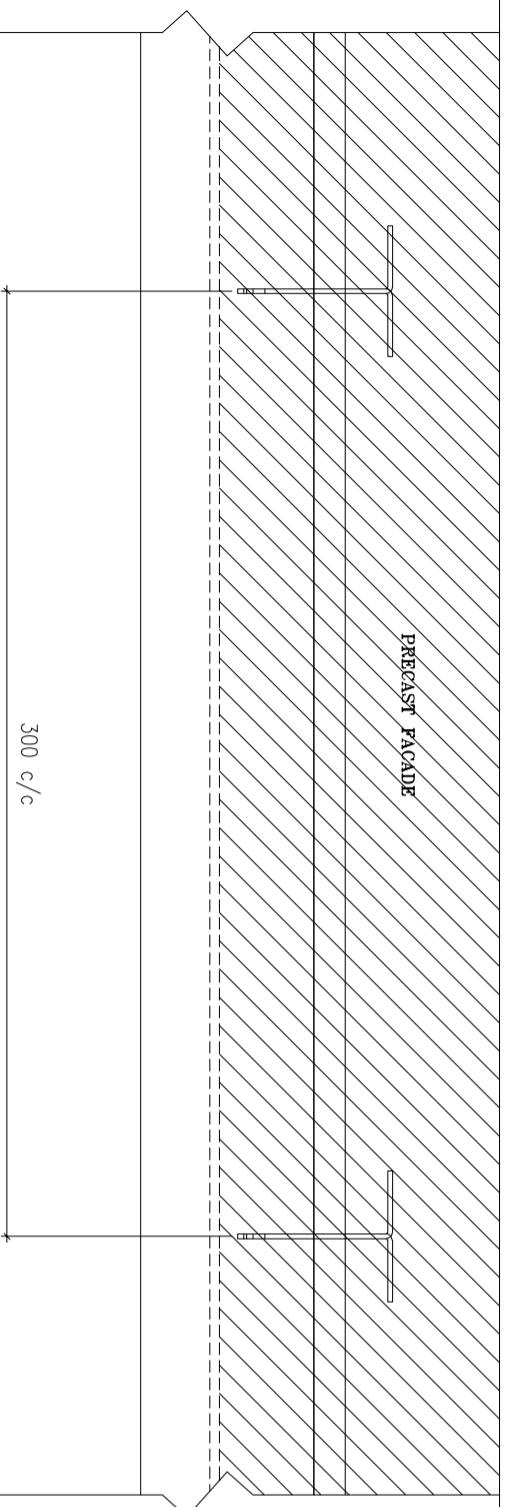
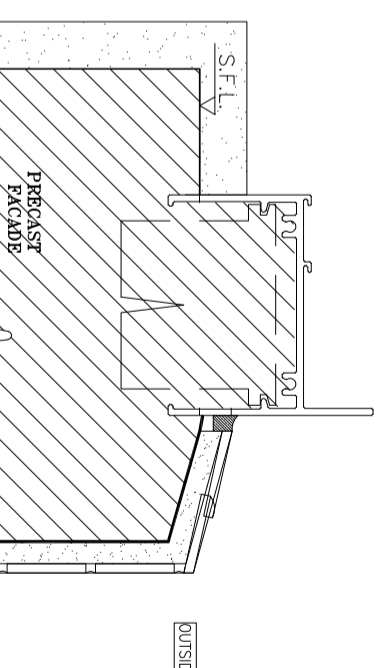

**3** HORIZONTAL DETAIL  
SCALE 1:2

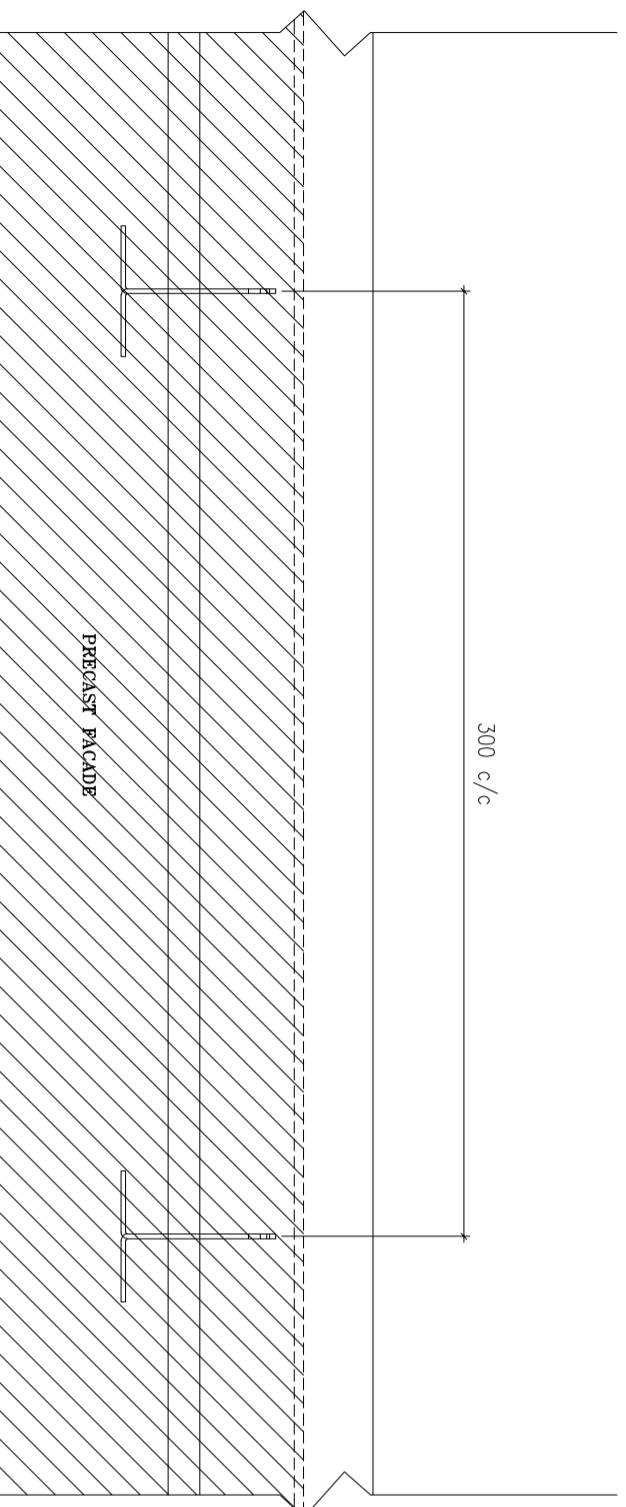

B.O. REF :

CLIENT :

**SUN HUNG KAI**  
REAL ESTATE AGENCY LTD.  
42/F SUN HUNG KAI CENTRE, WANGCHAI, HONGKONG

ARCHITECT :

**lwk&partners**  
a r c h i t e c t s

MAIN CONTRACTOR :

**怡輝建築有限公司**  
Yee Fai Building Contractors Ltd.

STRUCTURAL ENGINEER :

**ARUP**  
FAÇADE CONSULTANT:  
**ALPHA CONSULTING LIMITED**  
Steel Structure & Façade Specialist

NOTE :

1. ALL DIMENSIONS ARE IN mm.
2. ALL ELEVATIONS ARE VIEWED FROM OUTSIDE.
3. ALL DIMENSIONS TO BE VERIFIED ON SITE BEFORE FABRICATION.

LEGEND :

X1 DETAIL MARK NO.  
X001 REFER SHEET NO.

1. F.F.L.--FINISHED FLOOR LEVEL
2. S.F.L.--STRUCTURAL FLOOR LEVEL
3. (R) --REVERSED DETAIL

4. GLASS LEGEND

EQ1-1--8mmHS+12mm AIR GAP+10mmTP THK. I.G.U.  
EQ1-2--10mm THK. CLEAR TEMPERED GLASS  
EQ1-4--10mm THK. TEMPERED ACID ETCHED GLASS  
EQ1-1A--8mmHS+12mm AIR GAP+8mmTP THK. I.G.U.

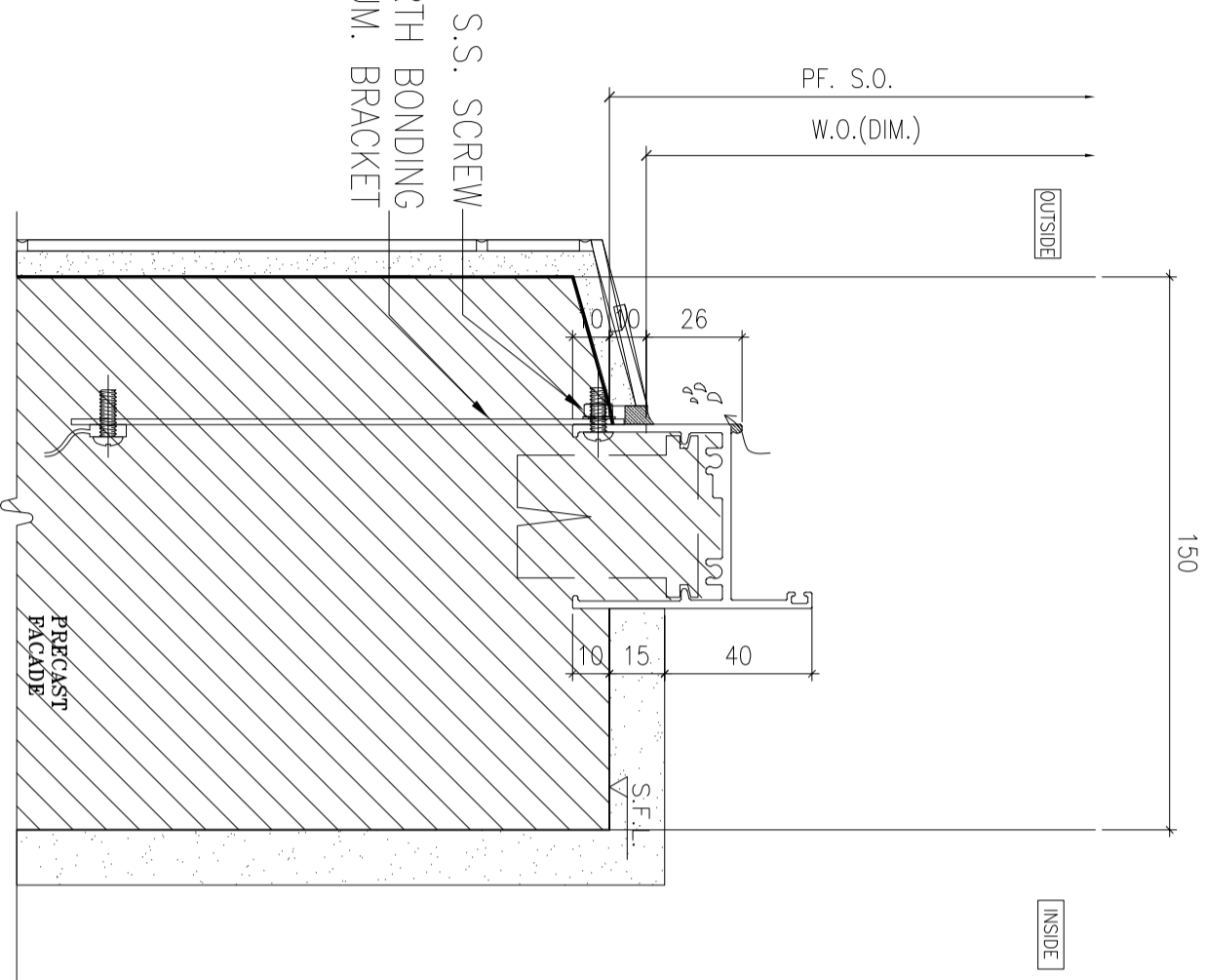

**1** HORIZONTAL DETAIL  
SCALE 1:2

TITLE :  
TYPICAL EARTHING  
BONDING DETAILS OF PRECAST

DATE : 02-Aug-21 SCALE : 1:40

DRAWN BY : Ivorn CHECKED BY :

**美特鋁質有限公司**  
MIDI ALUMINIUM FABRICATOR LTD.  
Units 6-8, Sunny Industrial Centre, 1/F  
610 Che Kwo Ling Road, Kowloon  
Tel:23489211-4 Fax:8522727666  
DWG NO. : JB56-SD-PW-DT76 REV. : -

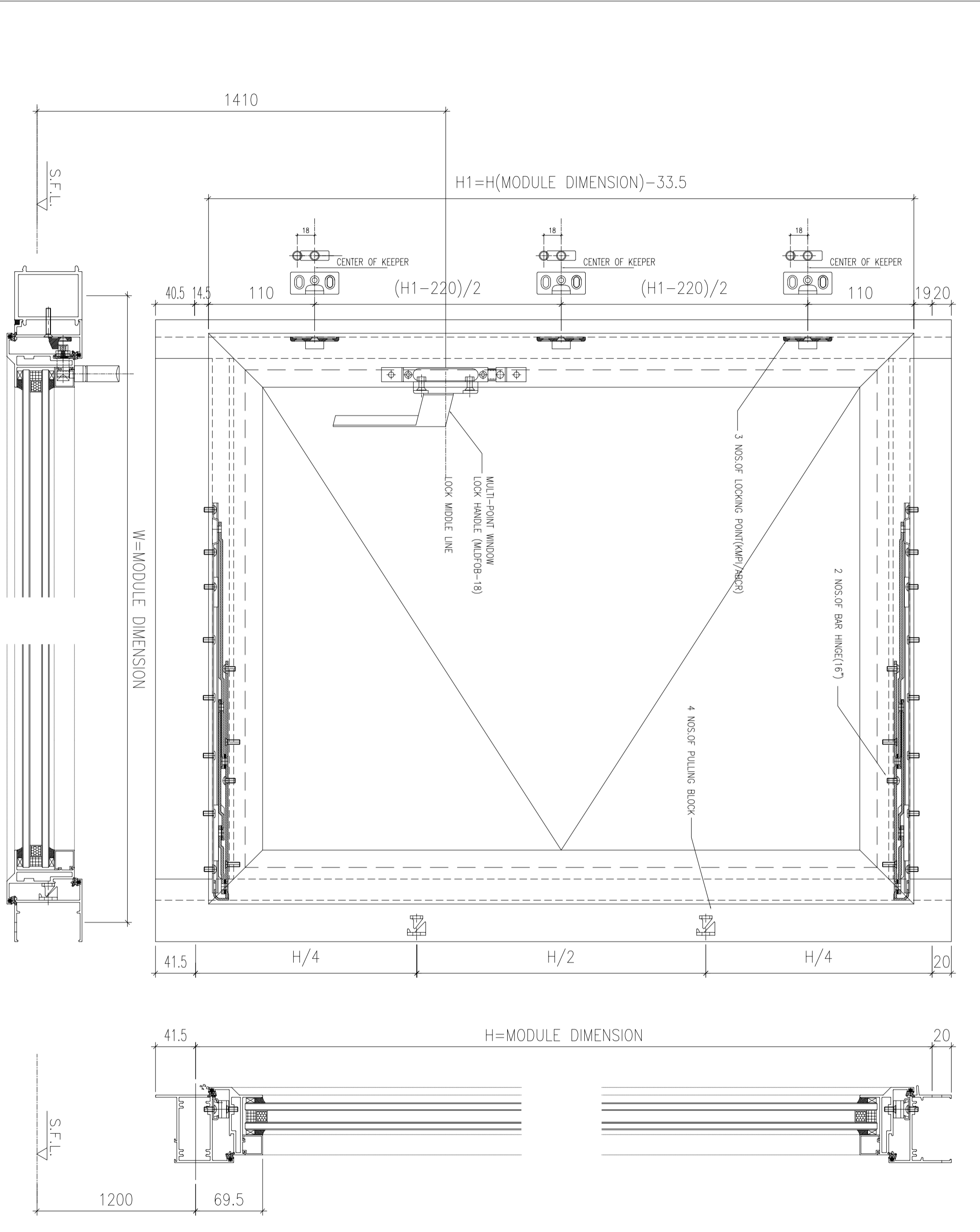

B.O. REF. : . . . . .

CLIENT :  
**SUN HUNG KAI**  
**REAL ESTATE AGENCY LTD.**  
 42/F SUN HUNG KAI CENTRE, WANGCHAI, HONGKONG

ARCHITECT :  
**lwk&partners**  
 a r c h i t e c t s

MAIN CONTRACTOR :  
**怡輝建築有限公司**  
**Yee Fai Building Contractors Ltd.**

STRUCTURAL ENGINEER :  
**ARUP**

FAÇADE CONSULTANT:  
**ALPHA CONSULTING LIMITED**  
 Steel Structure & Façade Specialist

NOTE :  
 1. ALL DIMENSIONS ARE IN mm.  
 2. ALL ELEVATIONS ARE VIEWED FROM OUTSIDE.  
 3. ALL DIMENSIONS TO BE VERIFIED ON SITE BEFORE FABRICATION.

LEGEND :  
 X1 --- DETAIL MARK NO.  
 X001 --- REFER SHEET NO.

1. F.F.L. -- FINISHED FLOOR LEVEL
  2. S.F.L. -- STRUCTURAL FLOOR LEVEL
  3. (R) -- REVERSED DETAIL
  4. GLASS LEGEND
- EQ1-1 -- 8mmHS+12mm AIR GAP+10mmTP THK. I.G.U.  
 EQ1-2 -- 10mm THK. CLEAR TEMPERED GLASS  
 EQ1-4 -- 10mm THK. TEMPERED ACID ETCHED GLASS  
 EQ1-1A -- 8mmHS+12mm AIR GAP+8mmTP THK. I.G.U.

NO.	DATE	REVISION	BY
JOB NO. :	J-856		
PROJECT :	PROPOSED DEVELOPMENT ABOVE LIGHT RAIL TIN WING STOP TSWTL NO.23, AREA 33, TIN SHUI WAI, N.T.		
TITLE :	TYPICAL EARTHING BONDING DETAILS OF PRECAST		
DATE :	02-Aug-21	SCALE :	1:60
DRAWN BY :	Ivon	CHECKED BY :	
<b>MIDI ALUMINIUM FABRICATOR LTD.</b> Units 6-8, Sunny Industrial Centre, 1/F 610 Che Kwo Ling Road, Kowloon Tel: 23489211-4 Fax: (852) 27276666 DWG NO. : JB56-SD-PW-D1777 REV. : -			

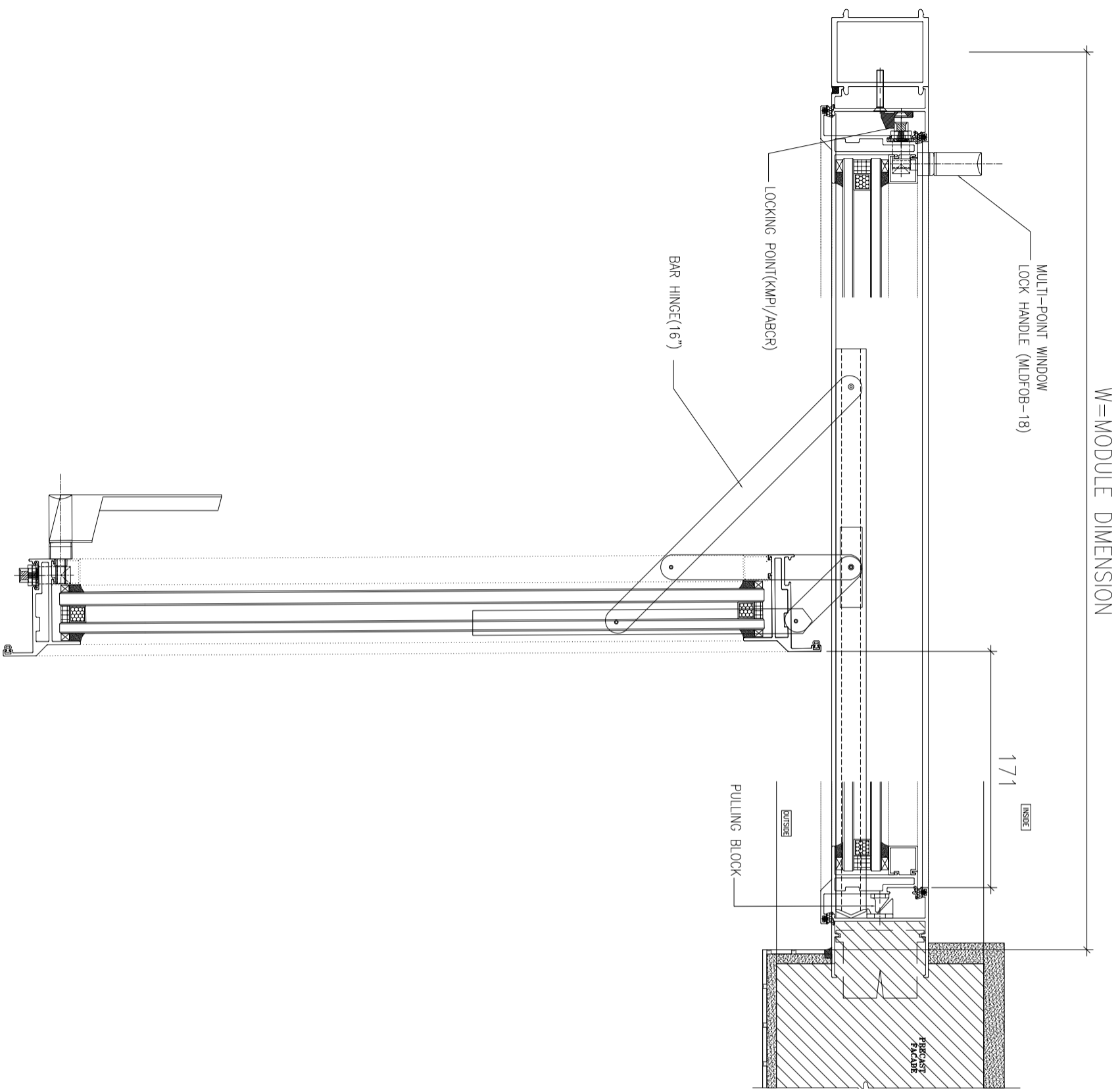

B.O. REF : .....

CLIENT :

**SUN HUNG KAI**  
**REAL ESTATE AGENCY LTD.**  
 42/F SUN HUNG KAI CENTRE, WANCHAI, HONGKONG

ARCHITECT :

**lwk&partners**  
 a r c h i t e c t s

MAIN CONTRACTOR :

**怡輝建築有限公司**  
**Yee Fai Building Contractors Ltd.**

STRUCTURAL ENGINEER :

**ARUP**

FAÇADE CONSULTANT:

**ALPHA CONSULTING LIMITED**  
 Steel Structure & Façade Specialist

NOTE :

1. ALL DIMENSIONS ARE IN mm.
2. ALL ELEVATIONS ARE VIEWED FROM OUTSIDE.
3. ALL DIMENSIONS TO BE VERIFIED ON SITE BEFORE FABRICATION.

LEGEND :

- X1 --- DETAIL MARK NO.
- X001 --- REFER SHEET NO.

1. F.F.L.--FINISHED FLOOR LEVEL
2. S.F.L.--STRUCTURAL FLOOR LEVEL
3. (R) --REVERSED DETAIL

4. GLASS LEGEND

- EG1-1--8mmHS+12mm AIR GAP+10mmTP THK. I.G.U.
- EG1-2--10mm THK. CLEAR TEMPERED GLASS
- EG1-4--10mm THK. TEMPERED ACID ETCHED GLASS
- EG1-1A--8mmHS+12mm AIR GAP+8mmTP THK. I.G.U.

NO.	DATE	REVISION	BY

JOB NO. : J-856

PROJECT :  
 PROPOSED DEVELOPMENT ABOVE  
 LIGHT RAIL TIN WING STOP TSWTL  
 NO.23,AREA 33,TIN SHUI WAI, N.T.

TITLE :  
 TYPICAL EARTHING  
 BONDING DETAILS OF PRECAST

DATE : 02-Aug-21 SCALE : 1:60

DRAWN BY : Ivorn CHECKED BY :

**美特鋁質有限公司**  
**MIDI ALUMINIUM FABRICATOR LTD.**  
 Units 6-8, Sunny Industrial Centre, 1/F  
 610 Che Kwo Ling Road, Kowloon  
 Tel:23489211-4 Fax:85212727666  
 DWG NO. : J856-SD-PW-DT78 REV. : -