

工程指示 / 要求簡箋 ENGINEER INSTRUCTIONS(E.I.)

工程指示編號:	EI- 6567	修改版本:	-
	HK-1709		
工程編號:	J 853	工程名稱:	延坪道
收件人:	生統	發件人:	Joe Chan
工程項目:	T6.7 幕牆室內收口	日期:	1/8/2023

<input checked="" type="checkbox"/> 原合約工程包	<input type="checkbox"/> 原合約工程加 / 減賬 QT-	<input type="checkbox"/> 新工程報價 QT-
--	--	------------------------------------

信件批核號碼/圖紙參考編號:	批核模具圖紙編號:
客戶指示附件:	管理內部批簽署:

<input type="checkbox"/> 初步鋁料 B.M.	<input type="checkbox"/> 加工拆圖, 然後生產	<input type="checkbox"/> 尺寸表
<input type="checkbox"/> 正式鋁料 B.M.	<input type="checkbox"/> 技術上資料/指示	<input type="checkbox"/> 報價
<input type="checkbox"/> 配件 B.M.	<input type="checkbox"/> 樣辦或貨品說明書	<input type="checkbox"/> 分判合約
<input type="checkbox"/> 其他:		

內容: 請依 附件資料, 生產室內收口鋁板, 送地盤.  
- 請分座分層包裝出貨  
(1+46頁)

急

完成上列要求日期: 15/8/2023 ASAP

國內

<input type="checkbox"/> 生產技術總監	<input type="checkbox"/> 連附件	<input type="checkbox"/> 技術部	<input type="checkbox"/> 連附件	<input type="checkbox"/> 生產部	<input type="checkbox"/> 連附件
<input type="checkbox"/> 採購部	<input type="checkbox"/> 連附件	<input checked="" type="checkbox"/> 生產統籌部	<input checked="" type="checkbox"/> 連附件	<input type="checkbox"/> 報關組	<input type="checkbox"/> 連附件
<input type="checkbox"/> 質檢部	<input type="checkbox"/> 連附件	<input type="checkbox"/> 會計部	<input type="checkbox"/> 連附件	<input type="checkbox"/> 機械設計部	<input type="checkbox"/> 連附件
<input type="checkbox"/> 香港辦	<input type="checkbox"/> 連附件	<input type="checkbox"/> 其他:			

香港

<input type="checkbox"/> 行政部	<input type="checkbox"/> 連附件	<input type="checkbox"/> 會計部	<input type="checkbox"/> 連附件	<input type="checkbox"/> 統籌部	<input type="checkbox"/> 連附件	<input type="checkbox"/> 工程部	<input type="checkbox"/> 連附件
<input type="checkbox"/> 採購部	<input type="checkbox"/> 連附件	<input type="checkbox"/> QS部	<input type="checkbox"/> 連附件	<input checked="" type="checkbox"/> 地盤管理	<input checked="" type="checkbox"/> 連附件	<input type="checkbox"/> 維修部	<input type="checkbox"/> 連附件

炳哥

*發件人簽署:		*組別成員批核簽署:	
傳遞編號:	HK1709/23	項目經理簽署:	

11

圖則登記表  
DRAWING REGISTER

工程名稱 Project Title: 九龍延坪道 T6T7座企/橫向室內收口鋁折件拆	接收日期 Receiving Date (適用於客戶圖則)
工程編號 Project No: J-853	年
	月
	日

分發予 Distributed To	年
	23
	5
	20

圖則編號 Drg. No.	圖則名稱 Drawing Title
H-MA01-21	企向收口鋁板
H-MA01-21(1)	企向收口鋁板(數據表)
H-MB01-21	企向收口鋁板
H-MB01-21(1)	企向收口鋁板(數據表)
H-MC01-21	企向收口鋁板
H-MC01-21(1)	企向收口鋁板(數據表)
H-MD01-21	企向收口鋁板
H-MD01-21(1)	企向收口鋁板(數據表)
W-MA01-601	橫向收口鋁板
W-MA01-601(1)	橫向收口鋁板(數據表)
W-MB01-601	橫向收口鋁板
W-MB01-601(1)	橫向收口鋁板(數據表)
W-MD01-706	橫向收口鋁板
W-MA01-711	橫向收口鋁板
W-MAFK01L-603	橫向收口鋁板
W-MAFK01R-603	橫向收口鋁板
W-MBFK01L-603	橫向收口鋁板
W-MBFK01R-603	橫向收口鋁板
W-MEFK01L-705	橫向收口鋁板

	修訂編號 Revision No.
1	-
2	-
3	-
4	-
5	-
6	-
7	-
8	-
9	-
10	-
11	-
12	-
13	-
14	-
15	-
16	-
17	-
18	-
19	-

2

圖則登記表 DRAWING REGISTER		接收日期 Receiving Date (適用於客戶圖則)						
工程名稱 Project Title: 九龍延坪道		年						
T6T7座企/橫向室內收口鋁折件拆		月						
工程編號 Project No: J-853		日						
分發予 Distributed To								
		年	23					
		月	5					
		日	20					
圖則編號 Drg. No.	圖則名稱 Drawing Title	修訂編號 Revision No.						
W-MEFK01L-705a	橫向收口鋁板	20	-					
W-MEFK01L-705b	橫向收口鋁板	21	-					
W-MA01-708	轉角橫向收口鋁板	22	-					
W-MA01-709	轉角橫向收口鋁板	23	-					
W-MC01-708	轉角橫向收口鋁板	24	-					
W-MC01-709	轉角橫向收口鋁板	25	-					
J853-SD-CW-4601	位置圖	26	-					
J853-SD-CW-4602	位置圖	27	-					
J853-SD-CW-4602A	位置圖	28	-					
J853-SD-CW-4606	位置圖	29	-					
J853-SD-CW-4607	位置圖	30	-					
J853-SD-CW-4603	位置圖	31	-					
J853-SD-CW-4604	位置圖	32	-					
J853-SD-CW-4605	位置圖	33	-					
J853-SD-CW-4608	位置圖	34	-					
J853-SD-CW-4609	位置圖	35	-					

3

美特鋁質 MIDI Aluminium Fabricator Ltd.		工程號: J-853	計算: 方強	日期:	2023.05.08	送呈: 胡哥							
地盤名稱: 九龍延坪道 <td>核對: 謝永林 <td></td> <th>日期:</th> <th>2023.05.20</th> <th>副本:</th> </td>		核對: 謝永林 <td></td> <th>日期:</th> <th>2023.05.20</th> <th>副本:</th>		日期:	2023.05.20	副本:							
項目類別: T6T7單元件 <td>批准:</td> <td></td> <th>日期:</th> <td></td> <td></td>		批准:		日期:									
修改版次:		A/C Code:		總V.F.:	186.03	總重量: 993.99							
						此BM依據拆圖資料計算							
序號	修改內容	鋁板圖號	鋁板名稱	顏色	實用	後備	總數	總重量	單件展開面積		單件V.F.		備註
									平方米	積	平方米	平方米	
1		H-MA01-21	企向收口鋁板	EC-DG-D334232-ZD1 (閃粉古銅)	28		28	28.573	0.188	5.272	0.19	5.34	
2		H-MA01-22	企向收口鋁板	EC-DG-D334232-ZD1 (閃粉古銅)	2		2	2.094	0.193	0.386	0.20	0.39	
3		H-MA01-23	企向收口鋁板	EC-DG-D334232-ZD1 (閃粉古銅)	6		6	6.537	0.201	1.206	0.20	1.22	
4		H-MA01-24	企向收口鋁板	EC-DG-D334232-ZD1 (閃粉古銅)	2		2	2.271	0.210	0.419	0.21	0.42	
5		H-MA01-21	企向收口鋁板	EC-DG-D334232-ZD1 (閃粉古銅)	14		14	14.286	0.188	2.636	0.19	2.67	
6		H-MA01-22	企向收口鋁板	EC-DG-D334232-ZD1 (閃粉古銅)	1		1	1.047	0.193	0.193	0.20	0.20	
7		H-MA01-23	企向收口鋁板	EC-DG-D334232-ZD1 (閃粉古銅)	3		3	3.269	0.201	0.603	0.20	0.61	
8		H-MA01-24	企向收口鋁板	EC-DG-D334232-ZD1 (閃粉古銅)	1		1	1.136	0.210	0.210	0.21	0.21	
9		H-MA01-21	企向收口鋁板	EC-DG-D334232-ZD1 (閃粉古銅)	20		20	20.409	0.188	3.766	0.19	3.82	
10		H-MA01-22	企向收口鋁板	EC-DG-D334232-ZD1 (閃粉古銅)	2		2	2.094	0.193	0.386	0.20	0.39	
11		H-MA01-23	企向收口鋁板	EC-DG-D334232-ZD1 (閃粉古銅)	4		4	4.358	0.201	0.804	0.20	0.81	
12		H-MA01-24	企向收口鋁板	EC-DG-D334232-ZD1 (閃粉古銅)	2		2	2.271	0.210	0.419	0.21	0.42	
13		H-MA01-21	企向收口鋁板	EC-DG-D334232-ZD1 (閃粉古銅)	20		20	20.409	0.188	3.766	0.19	3.82	
14		H-MA01-22	企向收口鋁板	EC-DG-D334232-ZD1 (閃粉古銅)	2		2	2.094	0.193	0.386	0.20	0.39	
15		H-MA01-23	企向收口鋁板	EC-DG-D334232-ZD1 (閃粉古銅)	4		4	4.358	0.201	0.804	0.20	0.81	
16		H-MA01-24	企向收口鋁板	EC-DG-D334232-ZD1 (閃粉古銅)	2		2	2.271	0.210	0.419	0.21	0.42	
17		H-MA01-21	企向收口鋁板	EC-DG-D334232-ZD1 (閃粉古銅)	13		13	13.266	0.188	2.448	0.19	2.48	
18		H-MA01-22	企向收口鋁板	EC-DG-D334232-ZD1 (閃粉古銅)	1		1	1.047	0.193	0.193	0.20	0.20	
19		H-MA01-23	企向收口鋁板	EC-DG-D334232-ZD1 (閃粉古銅)	2		2	2.179	0.201	0.402	0.20	0.41	
20		H-MA01-24	企向收口鋁板	EC-DG-D334232-ZD1 (閃粉古銅)	1		1	1.136	0.210	0.210	0.21	0.21	
21		H-MA01-21	企向收口鋁板	EC-DG-D334232-ZD1 (閃粉古銅)	13		13	13.266	0.188	2.448	0.19	2.48	
22		H-MA01-23	企向收口鋁板	EC-DG-D334232-ZD1 (閃粉古銅)	1		1	1.090	0.201	0.201	0.20	0.20	
23		H-MA01-26	企向收口鋁板	EC-DG-D334232-ZD1 (閃粉古銅)	1		1	0.997	0.184	0.184	0.19	0.19	
24		H-MA01-22	企向收口鋁板	EC-DG-D334232-ZD1 (閃粉古銅)	1		1	1.047	0.193	0.193	0.20	0.20	
25		H-MA01-23	企向收口鋁板	EC-DG-D334232-ZD1 (閃粉古銅)	1		1	1.090	0.201	0.201	0.20	0.20	
26		H-MA01-22	企向收口鋁板	EC-DG-D334232-ZD1 (閃粉古銅)	2		2	2.094	0.193	0.386	0.20	0.39	
27		H-MB01-21	企向收口鋁板	EC-DG-D334232-ZD1 (閃粉古銅)	28		28	23.530	0.155	4.341	0.16	4.40	
28		H-MB01-22	企向收口鋁板	EC-DG-D334232-ZD1 (閃粉古銅)	2		2	1.724	0.159	0.318	0.16	0.32	
29		H-MB01-23	企向收口鋁板	EC-DG-D334232-ZD1 (閃粉古銅)	6		6	5.384	0.166	0.993	0.17	1.01	
30		H-MB01-24	企向收口鋁板	EC-DG-D334232-ZD1 (閃粉古銅)	2		2	1.870	0.173	0.345	0.17	0.35	

	美特鋁質 有限公司 MIDI Aluminum Fabricator Ltd.	工程號: J-853 地盤名稱: 九龍延坪道 項目類別: T6T7單元件 修改版次:	計算: 方強 核對: 謝永林 批准:	日期: 日期: 日期: 總V.F.:	2023.05.08 2023.05.20 186.03 993.99	送呈: 胡哥 副本:
此BM依據折圖資料計算						

序號	修改內容	鋁板圖號	鋁板名稱	顏色	實用	後備	總數	總重量	單件展開面積		備註		
									平方米	平方厘米			
31		H-MB01-21	企向收口鋁板	EC-DG-D334232-ZD1 (閃粉古銅)	13		13	10.925	0.155	2.016	0.16	2.04	
32		H-MB01-22	企向收口鋁板	EC-DG-D334232-ZD1 (閃粉古銅)	1		1	0.862	0.159	0.159	0.16	0.16	
33		H-MB01-23	企向收口鋁板	EC-DG-D334232-ZD1 (閃粉古銅)	2		2	1.795	0.166	0.331	0.17	0.34	
34		H-MB01-24	企向收口鋁板	EC-DG-D334232-ZD1 (閃粉古銅)	1		1	0.935	0.173	0.173	0.17	0.17	
35		H-MB01-21	企向收口鋁板	EC-DG-D334232-ZD1 (閃粉古銅)	13		13	10.925	0.155	2.016	0.16	2.04	
36		H-MB01-23	企向收口鋁板	EC-DG-D334232-ZD1 (閃粉古銅)	1		1	0.897	0.166	0.166	0.17	0.17	
37		H-MB01-26	企向收口鋁板	EC-DG-D334232-ZD1 (閃粉古銅)	1		1	0.821	0.152	0.152	0.15	0.15	
38		H-MB01-22	企向收口鋁板	EC-DG-D334232-ZD1 (閃粉古銅)	1		1	0.862	0.159	0.159	0.16	0.16	
39		H-MB01-23	企向收口鋁板	EC-DG-D334232-ZD1 (閃粉古銅)	1		1	0.897	0.166	0.166	0.17	0.17	
40		H-MB01-21	企向收口鋁板	EC-DG-D334232-ZD1 (閃粉古銅)	11		11	9.244	0.155	1.706	0.16	1.73	
41		H-MB01-23	企向收口鋁板	EC-DG-D334232-ZD1 (閃粉古銅)	1		1	0.897	0.166	0.166	0.17	0.17	
42		H-MB01-24	企向收口鋁板	EC-DG-D334232-ZD1 (閃粉古銅)	1		1	0.935	0.173	0.173	0.17	0.17	
43		H-MC01-21	企向收口鋁板	EC-DG-D334232-ZD1 (閃粉古銅)	56		56	41.346	0.136	7.628	0.14	7.73	
44		H-MC01-22	企向收口鋁板	EC-DG-D334232-ZD1 (閃粉古銅)	4		4	3.030	0.140	0.559	0.14	0.57	
45		H-MC01-23	企向收口鋁板	EC-DG-D334232-ZD1 (閃粉古銅)	12		12	9.460	0.145	1.745	0.15	1.77	
46		H-MC01-24	企向收口鋁板	EC-DG-D334232-ZD1 (閃粉古銅)	4		4	3.287	0.152	0.606	0.15	0.61	
47		H-MC01-21	企向收口鋁板	EC-DG-D334232-ZD1 (閃粉古銅)	28		28	20.673	0.136	3.814	0.14	3.87	
48		H-MC01-22	企向收口鋁板	EC-DG-D334232-ZD1 (閃粉古銅)	2		2	1.515	0.140	0.280	0.14	0.28	
49		H-MC01-23	企向收口鋁板	EC-DG-D334232-ZD1 (閃粉古銅)	6		6	4.730	0.145	0.873	0.15	0.88	
50		H-MC01-24	企向收口鋁板	EC-DG-D334232-ZD1 (閃粉古銅)	2		2	1.643	0.152	0.303	0.15	0.31	
51		H-MC01-21	企向收口鋁板	EC-DG-D334232-ZD1 (閃粉古銅)	20		20	14.767	0.136	2.724	0.14	2.76	
52		H-MC01-22	企向收口鋁板	EC-DG-D334232-ZD1 (閃粉古銅)	2		2	1.515	0.140	0.280	0.14	0.28	
53		H-MC01-23	企向收口鋁板	EC-DG-D334232-ZD1 (閃粉古銅)	4		4	3.153	0.145	0.582	0.15	0.59	
54		H-MC01-24	企向收口鋁板	EC-DG-D334232-ZD1 (閃粉古銅)	2		2	1.643	0.152	0.303	0.15	0.31	
55		H-MC01-21	企向收口鋁板	EC-DG-D334232-ZD1 (閃粉古銅)	26		26	19.196	0.136	3.542	0.14	3.59	
56		H-MC01-22	企向收口鋁板	EC-DG-D334232-ZD1 (閃粉古銅)	2		2	1.515	0.140	0.280	0.14	0.28	
57		H-MC01-23	企向收口鋁板	EC-DG-D334232-ZD1 (閃粉古銅)	4		4	3.153	0.145	0.582	0.15	0.59	
58		H-MC01-24	企向收口鋁板	EC-DG-D334232-ZD1 (閃粉古銅)	2		2	1.643	0.152	0.303	0.15	0.31	
59		H-MC01-21	企向收口鋁板	EC-DG-D334232-ZD1 (閃粉古銅)	26		26	19.196	0.136	3.542	0.14	3.59	
60		H-MC01-22	企向收口鋁板	EC-DG-D334232-ZD1 (閃粉古銅)	2		2	1.515	0.140	0.280	0.14	0.28	

5

 <b>美特鋁質</b> 有限公司 MIDI Aluminum Fabricator Ltd.	工程號: J-853	計算: 方強	日期: 2023.05.08	送呈: 胡哥
	地盤名稱: 九龍延坪道	核對: 謝永林	日期: 2023.05.20	副本:
	項目類別: T6T7單元件	批准:		
	修改版次:	A/C Code:	總V.F.: 186.03	總重量: 993.99

序號	修改內容	鋁板圖號	鋁板名稱	顏色	實用	後備	總數	總重量	單件展開面積		單件V.F.		備註
									平方米	總展開面積	平方米	總V.F.	
61		H-MC01-23	企向收口鋁板	EC-DG-D334232-ZD1 (閃粉古銅)	4		4	3.153	0.145	0.582	0.15	0.59	
62		H-MC01-24	企向收口鋁板	EC-DG-D334232-ZD1 (閃粉古銅)	2		2	1.643	0.152	0.303	0.15	0.31	
63		H-MC01-21	企向收口鋁板	EC-DG-D334232-ZD1 (閃粉古銅)	26		26	19.196	0.136	3.542	0.14	3.59	
64		H-MC01-23	企向收口鋁板	EC-DG-D334232-ZD1 (閃粉古銅)	2		2	1.577	0.145	0.291	0.15	0.29	
65		H-MC01-26	企向收口鋁板	EC-DG-D334232-ZD1 (閃粉古銅)	2		2	1.443	0.133	0.266	0.13	0.27	
66		H-MC01-22	企向收口鋁板	EC-DG-D334232-ZD1 (閃粉古銅)	2		2	1.515	0.140	0.280	0.14	0.28	
67		H-MC01-23	企向收口鋁板	EC-DG-D334232-ZD1 (閃粉古銅)	2		2	1.577	0.145	0.291	0.15	0.29	
68		H-MC01-21	企向收口鋁板	EC-DG-D334232-ZD1 (閃粉古銅)	11		11	8.122	0.136	1.498	0.14	1.52	
69		H-MC01-23	企向收口鋁板	EC-DG-D334232-ZD1 (閃粉古銅)	1		1	0.788	0.145	0.145	0.15	0.15	
70		H-MC01-24	企向收口鋁板	EC-DG-D334232-ZD1 (閃粉古銅)	1		1	0.822	0.152	0.152	0.15	0.15	
71		H-MD01-21	企向收口鋁板	EC-DG-D334232-ZD1 (閃粉古銅)	14		14	24.623	0.324	4.543	0.33	4.60	
72		H-MD01-22	企向收口鋁板	EC-DG-D334232-ZD1 (閃粉古銅)	1		1	1.804	0.333	0.333	0.34	0.34	
73		H-MD01-23	企向收口鋁板	EC-DG-D334232-ZD1 (閃粉古銅)	3		3	5.634	0.346	1.039	0.35	1.05	
74		H-MD01-24	企向收口鋁板	EC-DG-D334232-ZD1 (閃粉古銅)	1		1	1.957	0.361	0.361	0.37	0.37	
75		H-MD01-21	企向收口鋁板	EC-DG-D334232-ZD1 (閃粉古銅)	10		10	17.588	0.324	3.245	0.33	3.29	
76		H-MD01-22	企向收口鋁板	EC-DG-D334232-ZD1 (閃粉古銅)	1		1	1.804	0.333	0.333	0.34	0.34	
77		H-MD01-23	企向收口鋁板	EC-DG-D334232-ZD1 (閃粉古銅)	2		2	3.756	0.346	0.693	0.35	0.70	
78		H-MD01-24	企向收口鋁板	EC-DG-D334232-ZD1 (閃粉古銅)	1		1	1.957	0.361	0.361	0.37	0.37	
79		H-MD01-21	企向收口鋁板	EC-DG-D334232-ZD1 (閃粉古銅)	10		10	17.588	0.324	3.245	0.33	3.29	
80		H-MD01-22	企向收口鋁板	EC-DG-D334232-ZD1 (閃粉古銅)	1		1	1.804	0.333	0.333	0.34	0.34	
81		H-MD01-23	企向收口鋁板	EC-DG-D334232-ZD1 (閃粉古銅)	2		2	3.756	0.346	0.693	0.35	0.70	
82		H-MD01-24	企向收口鋁板	EC-DG-D334232-ZD1 (閃粉古銅)	1		1	1.957	0.361	0.361	0.37	0.37	
83		H-MD01-21	企向收口鋁板	EC-DG-D334232-ZD1 (閃粉古銅)	13		13	22.864	0.324	4.218	0.33	4.28	
84		H-MD01-23	企向收口鋁板	EC-DG-D334232-ZD1 (閃粉古銅)	1		1	1.878	0.346	0.346	0.35	0.35	
85		H-MD01-29	企向收口鋁板	EC-DG-D334232-ZD1 (閃粉古銅)	1		1	1.802	0.333	0.333	0.34	0.34	
86		H-MD01-21	企向收口鋁板	EC-DG-D334232-ZD1 (閃粉古銅)	13		13	22.864	0.324	4.218	0.33	4.28	
87		H-MD01-23	企向收口鋁板	EC-DG-D334232-ZD1 (閃粉古銅)	1		1	1.878	0.346	0.346	0.35	0.35	
88		H-MD01-24	企向收口鋁板	EC-DG-D334232-ZD1 (閃粉古銅)	1		1	1.957	0.361	0.361	0.37	0.37	
89		H-MD01-25	企向收口鋁板	EC-DG-D334232-ZD1 (閃粉古銅)	1		1	1.636	0.302	0.302	0.31	0.31	
90		W-MA01-601	橫向收口鋁板	EC-DG-D334232-ZD1 (閃粉古銅)	18		18	18.086	0.185	3.337	0.19	3.40	

6

美特鋁質 MIDI Aluminium Fabricator Ltd.		工程號: J-853	計算: 方強	日期:	2023.05.08	送呈: 胡哥						
地盤名稱: 九龍延坪道 <td>核對: 謝永林 <td></td> <th>日期:</th> <th>2023.05.20</th> <th>副本:</th> </td>		核對: 謝永林 <td></td> <th>日期:</th> <th>2023.05.20</th> <th>副本:</th>		日期:	2023.05.20	副本:						
項目類別: T6T7單元件 <td>批准:</td> <td></td> <th>日期:</th> <td></td> <td></td>		批准:		日期:								
修改版次:		A/C Code:		總V.F.:	186.03	總重量: 993.99						
						此BM依據拆圖資料計算						
序號	修改內容	鋁板圖號	鋁板名稱	顏色	實用	後備	總數	總重量	總展開面積		備註	
									單件展開面積	總面積		單件V.F.
									平方米	平方米		
91		W-MA01-602	橫向收口鋁板	EC-DG-D334232-ZD1 (閃粉古銅)	18		18	20.244	0.208	3.735	0.21	3.79
92		W-MA01-604	橫向收口鋁板	EC-DG-D334232-ZD1 (閃粉古銅)	36		36	53.265	0.273	9.827	0.28	9.95
93		W-MA01-605	橫向收口鋁板	EC-DG-D334232-ZD1 (閃粉古銅)	18		18	20.223	0.207	3.731	0.21	3.79
94		W-MA01-606	橫向收口鋁板	EC-DG-D334232-ZD1 (閃粉古銅)	18		18	18.887	0.194	3.485	0.20	3.54
95		W-MA01-607	橫向收口鋁板	EC-DG-D334232-ZD1 (閃粉古銅)	13		13	9.012	0.128	1.663	0.13	1.71
96		W-MA01-608	橫向收口鋁板	EC-DG-D334232-ZD1 (閃粉古銅)	13		13	14.027	0.199	2.588	0.20	2.63
97		W-MA01-609	橫向收口鋁板	EC-DG-D334232-ZD1 (閃粉古銅)	13		13	14.219	0.202	2.624	0.21	2.67
98		W-MA01-607	橫向收口鋁板	EC-DG-D334232-ZD1 (閃粉古銅)	13		13	9.012	0.128	1.663	0.13	1.71
99		W-MA01-610	橫向收口鋁板	EC-DG-D334232-ZD1 (閃粉古銅)	13		13	11.534	0.164	2.128	0.17	2.17
100		W-MA01-701	橫向收口鋁板	EC-DG-D334232-ZD1 (閃粉古銅)	16		16	20.587	0.237	3.798	0.24	3.85
101		W-MA01-703	橫向收口鋁板	EC-DG-D334232-ZD1 (閃粉古銅)	16		16	18.213	0.210	3.360	0.21	3.41
102		W-MA01-704	橫向收口鋁板	EC-DG-D334232-ZD1 (閃粉古銅)	16		16	20.824	0.240	3.842	0.24	3.89
103		W-MA01-706	橫向收口鋁板	EC-DG-D334232-ZD1 (閃粉古銅)	14		14	19.052	0.251	3.515	0.25	3.56
104		W-MA01-707	橫向收口鋁板	EC-DG-D334232-ZD1 (閃粉古銅)	14		14	20.922	0.276	3.860	0.28	3.91
105		W-MA01-711	橫向收口鋁板	EC-DG-D334232-ZD1 (閃粉古銅)	1		1	0.426	0.079	0.079	0.08	0.08
106		W-MA01-712	橫向收口鋁板	EC-DG-D334232-ZD1 (閃粉古銅)	1		1	0.901	0.166	0.166	0.17	0.17
107		W-MA01-713	橫向收口鋁板	EC-DG-D334232-ZD1 (閃粉古銅)	13		13	22.513	0.320	4.154	0.32	4.20
108		W-MA01-714	橫向收口鋁板	EC-DG-D334232-ZD1 (閃粉古銅)	13		13	11.303	0.160	2.085	0.16	2.13
109		W-MA01-715	橫向收口鋁板	EC-DG-D334232-ZD1 (閃粉古銅)	1		1	1.039	0.192	0.192	0.19	0.19
110		W-MA01-716	橫向收口鋁板	EC-DG-D334232-ZD1 (閃粉古銅)	1		1	1.504	0.278	0.278	0.28	0.28
111		W-MA01-717	橫向收口鋁板	EC-DG-D334232-ZD1 (閃粉古銅)	1		1	1.246	0.230	0.230	0.23	0.23
112		W-MA01-718	橫向收口鋁板	EC-DG-D334232-ZD1 (閃粉古銅)	1		1	1.611	0.297	0.297	0.30	0.30
113		W-MB01-601	橫向收口鋁板	EC-DG-D334232-ZD1 (閃粉古銅)	1		1	0.642	0.119	0.119	0.12	0.12
114		W-MB01-602	橫向收口鋁板	EC-DG-D334232-ZD1 (閃粉古銅)	1		1	0.719	0.133	0.133	0.13	0.13
115		W-MB01-604	橫向收口鋁板	EC-DG-D334232-ZD1 (閃粉古銅)	2		2	1.892	0.175	0.349	0.18	0.35
116		W-MB01-605	橫向收口鋁板	EC-DG-D334232-ZD1 (閃粉古銅)	1		1	0.718	0.133	0.133	0.13	0.13
117		W-MB01-606	橫向收口鋁板	EC-DG-D334232-ZD1 (閃粉古銅)	1		1	0.671	0.124	0.124	0.13	0.13
118		W-MB01-607	橫向收口鋁板	EC-DG-D334232-ZD1 (閃粉古銅)	1		1	0.443	0.082	0.082	0.08	0.08
119		W-MB01-608	橫向收口鋁板	EC-DG-D334232-ZD1 (閃粉古銅)	1		1	0.690	0.127	0.127	0.13	0.13
120		W-MB01-609	橫向收口鋁板	EC-DG-D334232-ZD1 (閃粉古銅)	1		1	0.699	0.129	0.129	0.13	0.13

美特鋁質有限公司 MIDI Aluminium Fabricator Ltd.		工程號: J-853	計算: 方強	日期: 2023.05.08	送呈: 胡哥							
地盤名稱: 九龍延坪道		核對: 謝永林	日期: 2023.05.20	副本:								
項目類別: T6T7單元件		批准:	總V.F.:	總重量: 993.99	此BM依據拆圖資料計算							
修改版次:		A/C Code:	186.03	總重量:								
序號	修改內容	鋁板圖號	鋁板名稱	顏色	實用	後備	總數	總重量	單件展開面積	單件V.F.	總V.F.	備註
									平方米	平方米		
121		W-MB01-607	橫向收口鋁板	EC-DG-D334232-ZD1 (閃粉古銅)	1		1	0.443	0.082	0.08	0.08	
122		W-MB01-610	橫向收口鋁板	EC-DG-D334232-ZD1 (閃粉古銅)	1		1	0.567	0.105	0.11	0.11	
123		W-MB01-701	橫向收口鋁板	EC-DG-D334232-ZD1 (閃粉古銅)	1		1	0.823	0.152	0.15	0.15	
124		W-MB01-703	橫向收口鋁板	EC-DG-D334232-ZD1 (閃粉古銅)	1		1	0.728	0.134	0.14	0.14	
125		W-MB01-704	橫向收口鋁板	EC-DG-D334232-ZD1 (閃粉古銅)	1		1	0.832	0.154	0.16	0.16	
126		W-MB01-711	橫向收口鋁板	EC-DG-D334232-ZD1 (閃粉古銅)	1		1	0.272	0.050	0.05	0.05	
127		W-MB01-712	橫向收口鋁板	EC-DG-D334232-ZD1 (閃粉古銅)	1		1	0.576	0.106	0.11	0.11	
128		W-MB01-719	橫向收口鋁板	EC-DG-D334232-ZD1 (閃粉古銅)	1		1	0.658	0.121	0.12	0.12	
129		W-MB01-720	橫向收口鋁板	EC-DG-D334232-ZD1 (閃粉古銅)	1		1	0.962	0.177	0.18	0.18	
130		W-MB01-721	橫向收口鋁板	EC-DG-D334232-ZD1 (閃粉古銅)	1		1	0.797	0.147	0.15	0.15	
131		W-MB01-722	橫向收口鋁板	EC-DG-D334232-ZD1 (閃粉古銅)	1		1	1.024	0.189	0.19	0.19	
132		W-MD01-706	橫向收口鋁板	EC-DG-D334232-ZD1 (閃粉古銅)	1		1	0.963	0.178	0.18	0.18	
133		W-MD01-707	橫向收口鋁板	EC-DG-D334232-ZD1 (閃粉古銅)	1		1	1.058	0.195	0.20	0.20	
134		W-MA01-710	橫向收口鋁板	EC-DG-D334232-ZD1 (閃粉古銅)	15		15	18.606	0.229	0.23	3.48	
135		W-MA01-714	橫向收口鋁板	EC-DG-D334232-ZD1 (閃粉古銅)	13		13	11.303	0.160	0.16	2.13	
136		W-MAFK01L-603	橫向收口鋁板	EC-DG-D334232-ZD1 (閃粉古銅)	18		18	7.670	0.079	0.08	1.47	
137		W-MAFK01L-705	橫向收口鋁板	EC-DG-D334232-ZD1 (閃粉古銅)	14		14	6.630	0.087	0.09	1.27	
138		W-MAFK01R-603	橫向收口鋁板	EC-DG-D334232-ZD1 (閃粉古銅)	18		18	7.670	0.079	0.08	1.47	
139		W-MAFK01R-702	橫向收口鋁板	EC-DG-D334232-ZD1 (閃粉古銅)	16		16	6.818	0.079	0.08	1.31	
140		W-MBFK01L-603	橫向收口鋁板	EC-DG-D334232-ZD1 (閃粉古銅)	1		1	0.272	0.050	0.05	0.05	
141		W-MBFK01R-603	橫向收口鋁板	EC-DG-D334232-ZD1 (閃粉古銅)	1		1	0.272	0.050	0.05	0.05	
142		W-MBFK01R-702	橫向收口鋁板	EC-DG-D334232-ZD1 (閃粉古銅)	1		1	0.272	0.050	0.05	0.05	
143		W-MEFK01L-705	橫向收口鋁板	EC-DG-D334232-ZD1 (閃粉古銅)	1		1	2.177	0.268	0.28	0.28	
144		W-MEFK01L-705a	橫向收口鋁板	鍍化	1		1	0.000	0.000	0.00	0.00	
145		W-MEFK01L-705b	橫向收口鋁板	鍍化	1		1	0.000	0.000	0.00	0.00	
146		W-MA01-708	轉角橫向收口鋁板	EC-DG-D334232-ZD1 (閃粉古銅)	15		15	19.897	0.245	0.25	3.72	
147		W-MA01-709	轉角橫向收口鋁板	EC-DG-D334232-ZD1 (閃粉古銅)	15		15	7.193	0.088	0.09	1.38	
148		W-MC01-708	轉角橫向收口鋁板	EC-DG-D334232-ZD1 (閃粉古銅)	1		1	0.927	0.171	0.17	0.17	
149		W-MC01-709	轉角橫向收口鋁板	EC-DG-D334232-ZD1 (閃粉古銅)	1		1	0.335	0.062	0.06	0.06	
					合計:		1004	993.991	186.259		186.033	

8

				T6企/橫向室內收口鋁折件/樓層/數量派位																							
序號	座數	位置	圖號	5F	6F	7F	8F	9F	10F	11F	12F	15F	16F	17F	18F	19F	20F	21F	22F	23F	25F	26F	合計				
1	T6	J853-SD-CW-4601右	H-MA01-21		2	2	2	2	2	2	2	2	2	2	2	2	2	2	2	2			28				
2	T6	J853-SD-CW-4601右	H-MA01-22																				2	2			
3	T6	J853-SD-CW-4601右	H-MA01-23	2									2									2	6				
4	T6	J853-SD-CW-4601右	H-MA01-24																		2		2				
5	T6	J853-SD-CW-4602A	H-MA01-21		1	1	1	1	1	1	1	1		1	1	1	1	1	1				14				
6	T6	J853-SD-CW-4602A	H-MA01-22																				1	1			
7	T6	J853-SD-CW-4602A	H-MA01-23	1									1									1	3				
8	T6	J853-SD-CW-4602A	H-MA01-24																		1		1				
9	T6	J853-SD-CW-4606右	H-MA01-21						2	2	2	2		2	2	2	2	2	2	2			20				
10	T6	J853-SD-CW-4606右	H-MA01-22																			2	2				
11	T6	J853-SD-CW-4606右	H-MA01-23										2									2	4				
12	T6	J853-SD-CW-4606右	H-MA01-24																		2		2				
13	T6	J853-SD-CW-4607右	H-MA01-21						2	2	2	2		2	2	2	2	2	2	2			20				
14	T6	J853-SD-CW-4607右	H-MA01-22																			2	2				
15	T6	J853-SD-CW-4607右	H-MA01-23										2									2	4				
16	T6	J853-SD-CW-4607右	H-MA01-24																		2		2				
17	T6	J853-SD-CW-4602	H-MB01-21		2	2	2	2	2	2	2	2		2	2	2	2	2	2				28				
18	T6	J853-SD-CW-4602	H-MB01-22																			2	2				
19	T6	J853-SD-CW-4602	H-MB01-23	2									2									2	6				
20	T6	J853-SD-CW-4602	H-MB01-24																		2		2				
21	T6	J853-SD-CW-4602	H-MC01-21		4	4	4	4	4	4	4	4		4	4	4	4	4	4				56				
22	T6	J853-SD-CW-4602	H-MC01-22																			4	4				
23	T6	J853-SD-CW-4602	H-MC01-23	4									4									4	12				
24	T6	J853-SD-CW-4602	H-MC01-24																		4		4				
25	T6	J853-SD-CW-4602A	H-MC01-21		2	2	2	2	2	2	2	2		2	2	2	2	2	2				28				
26	T6	J853-SD-CW-4602A	H-MC01-22																			2	2				
27	T6	J853-SD-CW-4602A	H-MC01-23	2									2									2	6				
28	T6	J853-SD-CW-4602A	H-MC01-24																		2		2				
29	T6	J853-SD-CW-4606右	H-MC01-21						2	2	2	2		2	2	2	2	2	2				20				
30	T6	J853-SD-CW-4606右	H-MC01-22																			2	2				
31	T6	J853-SD-CW-4606右	H-MC01-23										2									2	4				
32	T6	J853-SD-CW-4606右	H-MC01-24																		2		2				
33	T6	J853-SD-CW-4601左	H-MD01-21		1	1	1	1	1	1	1	1		1	1	1	1	1	1				14				
34	T6	J853-SD-CW-4601左	H-MD01-22																			1	1				
35	T6	J853-SD-CW-4601左	H-MD01-23	1									1									1	3				
36	T6	J853-SD-CW-4601左	H-MD01-24																		1		1				
37	T6	J853-SD-CW-4606左	H-MD01-21						1	1	1	1		1	1	1	1	1	1				10				
38	T6	J853-SD-CW-4606左	H-MD01-22																			1	1				
39	T6	J853-SD-CW-4606左	H-MD01-23										1									1	2				
40	T6	J853-SD-CW-4606左	H-MD01-24																		1		1				
41	T6	J853-SD-CW-4607左	H-MD01-21						1	1	1	1		1	1	1	1	1	1				10				
42	T6	J853-SD-CW-4607左	H-MD01-22																			1	1				
43	T6	J853-SD-CW-4607左	H-MD01-23										1									1	2				
44	T6	J853-SD-CW-4607左	H-MD01-24																		1		1				
45	T6	J853-SD-CW-4601左	W-MA01-601	1	1	1	1	1	1	1	1	1	1	1	1	1	1	1	1	1	1	1	18				
46	T6	J853-SD-CW-4601右	W-MA01-602	1	1	1	1	1	1	1	1	1	1	1	1	1	1	1	1	1	1	1	18				
47	T6	J853-SD-CW-4602	W-MA01-604	2	2	2	2	2	2	2	2	2	2	2	2	2	2	2	2	2	2	2	36				
48	T6	J853-SD-CW-4602A	W-MA01-605	1	1	1	1	1	1	1	1	1	1	1	1	1	1	1	1	1	1	1	18				
49	T6	J853-SD-CW-4602A	W-MA01-606	1	1	1	1	1	1	1	1	1	1	1	1	1	1	1	1	1	1	1	18				
50	T6	J853-SD-CW-4606左	W-MA01-607						1	1	1	1	1	1	1	1	1	1	1	1	1	1	13				
51	T6	J853-SD-CW-4606右	W-MA01-608						1	1	1	1	1	1	1	1	1	1	1	1	1	1	13				
52	T6	J853-SD-CW-4606右	W-MA01-609						1	1	1	1	1	1	1	1	1	1	1	1	1	1	13				
53	T6	J853-SD-CW-4607左	W-MA01-607						1	1	1	1	1	1	1	1	1	1	1	1	1	1	13				
54	T6	J853-SD-CW-4607右	W-MA01-610						1	1	1	1	1	1	1	1	1	1	1	1	1	1	13				
55	T6	J853-SD-CW-4601左	W-MB01-601																			1	1				
56	T6	J853-SD-CW-4601右	W-MB01-602																			1	1				
57	T6	J853-SD-CW-4602	W-MB01-604																			2	2				
58	T6	J853-SD-CW-4602A	W-MB01-605																			1	1				
59	T6	J853-SD-CW-4602A	W-MB01-606																			1	1				
60	T6	J853-SD-CW-4606左	W-MB01-607																			1	1				

				T6企/橫向室內收口鋁折件/樓層/數量派位																						
序號	座數	位置	圖號	5F	6F	7F	8F	9F	10F	11F	12F	15F	16F	17F	18F	19F	20F	21F	22F	23F	25F	26F	合計			
61	T6	J853-SD-CW-4606右	W-MB01-608																				1	1		
62	T6	J853-SD-CW-4606右	W-MB01-609																				1	1		
63	T6	J853-SD-CW-4607左	W-MB01-607																				1	1		
64	T6	J853-SD-CW-4607右	W-MB01-610																				1	1		
65	T6	J853-SD-CW-4602	W-MAFK01L-603	1	1	1	1	1	1	1	1	1	1	1	1	1	1	1	1	1	1	1	1	18		
66	T6	J853-SD-CW-4602	W-MAFK01R-603	1	1	1	1	1	1	1	1	1	1	1	1	1	1	1	1	1	1	1	1	18		
67	T6	J853-SD-CW-4602	W-MBFK01L-603																				1	1		
68	T6	J853-SD-CW-4602	W-MBFK01R-603																				1	1		
合計：				20	20	20	20	20	33	33	33	33	33	33	33	33	33	33	33	33	33	33	31	35	562	

				T7企/橫向室內收口鉛折件/樓層/數量派位																							
序號	座數	位置	圖號	5F	6F	7F	8F	9F	10F	11F	12F	15F	16F	17F	18F	19F	20F	21F	22F	23F	25F	26F	合計				
1	T7	J853-SD-CW-4603右	H-MA01-21			1	1	1	1	1	1	1		1	1	1	1	1	1				13				
2	T7	J853-SD-CW-4603右	H-MA01-22																				1	1			
3	T7	J853-SD-CW-4603右	H-MA01-23										1									1		2			
4	T7	J853-SD-CW-4603右	H-MA01-24																		1			1			
5	T7	J853-SD-CW-4604右	H-MA01-21			1	1	1	1	1	1	1		1	1	1	1	1	1				13				
6	T7	J853-SD-CW-4604右	H-MA01-23										1											1			
7	T7	J853-SD-CW-4604右	H-MA01-26																		1			1			
8	T7	J853-SD-CW-4608左	H-MA01-22																				1	1			
9	T7	J853-SD-CW-4608左	H-MA01-23																			1		1			
10	T7	J853-SD-CW-4609	H-MA01-22																				2	2			
11	T7	J853-SD-CW-4603左	H-MB01-21			1	1	1	1	1	1	1		1	1	1	1	1	1				13				
12	T7	J853-SD-CW-4603左	H-MB01-22																				1	1			
13	T7	J853-SD-CW-4603左	H-MB01-23										1									1		2			
14	T7	J853-SD-CW-4603左	H-MB01-24																		1			1			
15	T7	J853-SD-CW-4604右	H-MB01-21			1	1	1	1	1	1	1		1	1	1	1	1	1				13				
16	T7	J853-SD-CW-4604右	H-MB01-23										1											1			
17	T7	J853-SD-CW-4604右	H-MB01-26																		1			1			
18	T7	J853-SD-CW-4608左	H-MB01-22																				1	1			
19	T7	J853-SD-CW-4608左	H-MB01-23																			1		1			
20	T7	J853-SD-CW-4608右	H-MB01-21					1	1	1	1	1		1	1	1	1	1	1				11				
21	T7	J853-SD-CW-4608右	H-MB01-23										1											1			
22	T7	J853-SD-CW-4608右	H-MB01-24																			1		1			
23	T7	J853-SD-CW-4603左	H-MC01-21			2	2	2	2	2	2	2		2	2	2	2	2	2				26				
24	T7	J853-SD-CW-4603左	H-MC01-22																				2	2			
25	T7	J853-SD-CW-4603左	H-MC01-23										2									2		4			
26	T7	J853-SD-CW-4603左	H-MC01-24																		2			2			
27	T7	J853-SD-CW-4603右	H-MC01-21			2	2	2	2	2	2	2		2	2	2	2	2	2				26				
28	T7	J853-SD-CW-4603右	H-MC01-22																				2	2			
29	T7	J853-SD-CW-4603右	H-MC01-23											2								2		4			
30	T7	J853-SD-CW-4603右	H-MC01-24																		2			2			
31	T7	J853-SD-CW-4604右	H-MC01-21			2	2	2	2	2	2	2		2	2	2	2	2	2				26				
32	T7	J853-SD-CW-4604右	H-MC01-23										2											2			
33	T7	J853-SD-CW-4604右	H-MC01-26																		2			2			
34	T7	J853-SD-CW-4608左	H-MC01-22																				2	2			
35	T7	J853-SD-CW-4608左	H-MC01-23																			2		2			
36	T7	J853-SD-CW-4608右	H-MC01-21					1	1	1	1	1		1	1	1	1	1	1				11				
37	T7	J853-SD-CW-4608右	H-MC01-23										1											1			
38	T7	J853-SD-CW-4608右	H-MC01-24																			1		1			
39	T7	J853-SD-CW-4604左	H-MD01-21			1	1	1	1	1	1	1		1	1	1	1	1	1				13				
40	T7	J853-SD-CW-4604左	H-MD01-23										1											1			
41	T7	J853-SD-CW-4604左	H-MD01-29																			1		1			
42	T7	J853-SD-CW-4605	H-MD01-21			1	1	1	1	1	1	1		1	1	1	1	1	1				13				
43	T7	J853-SD-CW-4605	H-MD01-23										1											1			
44	T7	J853-SD-CW-4605	H-MD01-24																			1		1			
45	T7	J853-SD-CW-4605	H-MD01-25																			1		1			
46	T7	J853-SD-CW-4603左	W-MA01-701			1	1	1	1	1	1	1	1	1	1	1	1	1	1	1	1	1	1	16			
47	T7	J853-SD-CW-4603右	W-MA01-703			1	1	1	1	1	1	1	1	1	1	1	1	1	1	1	1	1	1	16			
48	T7	J853-SD-CW-4603右	W-MA01-704			1	1	1	1	1	1	1	1	1	1	1	1	1	1	1	1	1	1	16			
49	T7	J853-SD-CW-4604右	W-MA01-706			1	1	1	1	1	1	1	1	1	1	1	1	1	1	1				14			
50	T7	J853-SD-CW-4604右	W-MA01-707			1	1	1	1	1	1	1	1	1	1	1	1	1	1	1				14			
51	T7	J853-SD-CW-4608左	W-MA01-710			1	1	1	1	1	1	1	1	1	1	1	1	1	1	1	1	1		15			
52	T7	J853-SD-CW-4608左	W-MA01-712																				1	1			
53	T7	J853-SD-CW-4608右	W-MA01-713					1	1	1	1	1	1	1	1	1	1	1	1	1	1			13			
54	T7	J853-SD-CW-4608右	W-MA01-714					1	1	1	1	1	1	1	1	1	1	1	1	1	1			13			
55	T7	J853-SD-CW-4609	W-MA01-715																				1	1			
56	T7	J853-SD-CW-4609	W-MA01-716																				1	1			
57	T7	J853-SD-CW-4609	W-MA01-717																				1	1			
58	T7	J853-SD-CW-4609	W-MA01-718																				1	1			
59	T7	J853-SD-CW-4603左	W-MB01-701																				1	1			
60	T7	J853-SD-CW-4603右	W-MB01-703																				1	1			

				T7企/橫向室內收口鋁折件/樓層/數量派位																						
序號	座數	位置	圖號	5F	6F	7F	8F	9F	10F	11F	12F	15F	16F	17F	18F	19F	20F	21F	22F	23F	25F	26F	合計			
61	T7	J853-SD-CW-4603右	W-MB01-704																				1	1		
62	T7	J853-SD-CW-4608左	W-MB01-711																				1	1		
63	T7	J853-SD-CW-4608左	W-MB01-712																				1	1		
64	T7	J853-SD-CW-4609	W-MB01-715																				1	1		
65	T7	J853-SD-CW-4609	W-MB01-716																				1	1		
66	T7	J853-SD-CW-4609	W-MB01-717																				1	1		
67	T7	J853-SD-CW-4609	W-MB01-718																				1	1		
68	T7	J853-SD-CW-4604右	W-MD01-706																		1			1		
69	T7	J853-SD-CW-4604右	W-MD01-707																		1			1		
70	T7	J853-SD-CW-4608左	W-MA01-711																			1		1		
71	T7	J853-SD-CW-4608右	W-MA01-714					1	1	1	1	1	1	1	1	1	1	1	1	1	1			13		
72	T7	J853-SD-CW-4604左	W-MAFK01L-705			1	1	1	1	1	1	1	1	1	1	1	1	1	1	1				14		
73	T7	J853-SD-CW-4603左	W-MAFK01R-702			1	1	1	1	1	1	1	1	1	1	1	1	1	1	1	1	1		16		
74	T7	J853-SD-CW-4603左	W-MBFK01R-702																				1	1		
75	T7	J853-SD-CW-4604左	W-MEFK01L-705																		1			1		
76	T7	J853-SD-CW-4604左	W-MEFK01L-705a																		1			1		
77	T7	J853-SD-CW-4604左	W-MEFK01L-705b																		1			1		
78	T7	J853-SD-CW-4605	W-MA01-708			1	1	1	1	1	1	1	1	1	1	1	1	1	1	1	1			15		
79	T7	J853-SD-CW-4605	W-MA01-709			1	1	1	1	1	1	1	1	1	1	1	1	1	1	1	1			15		
80	T7	J853-SD-CW-4203右	W-MC01-708																				1	1		
81	T7	J853-SD-CW-4203右	W-MC01-709																				1	1		
合計：				0	0	22	22	27	27	27	27	27	27	27	27	27	27	27	27	27	27	29	23	22	442	





美特鋁質有限公司  
MIDI Aluminium Fabricator Ltd.

拆圖見上頁

工程號 J-853 地盤 延坪道住宅

序號	物料編號	L	數量	位置	分格尺寸	樓層	樓層數	每層數量	座數
1	H-MA01-21	2215	28	J853-SD-CW-4601右	2192.5	6/F-15/F,17/F-22/F	14	2	T6
2	H-MA01-22	2272.5	2	J853-SD-CW-4601右	2342.5	26/F	1	2	T6
3	H-MA01-23	2365	6	J853-SD-CW-4601右	2342.5	5/F,16/F,25/F	3	2	T6
4	H-MA01-24	2465	2	J853-SD-CW-4601右	2442.5	23/F	1	2	T6
5	H-MA01-21	2215	14	J853-SD-CW-4602A	2192.5	6/F-15/F,17/F-22/F	14	1	T6
6	H-MA01-22	2272.5	1	J853-SD-CW-4602A	2342.5	26/F	1	1	T6
7	H-MA01-23	2365	3	J853-SD-CW-4602A	2342.5	5/F,16/F,25/F	3	1	T6
8	H-MA01-24	2465	1	J853-SD-CW-4602A	2442.5	23/F	1	1	T6
9	H-MA01-21	2215	20	J853-SD-CW-4606右	2192.5	10/F-15/F,17/F-22/F	10	2	T6
10	H-MA01-22	2272.5	2	J853-SD-CW-4606右	2342.5	26/F	1	2	T6
11	H-MA01-23	2365	4	J853-SD-CW-4606右	2342.5	16/F,25/F	2	2	T6
12	H-MA01-24	2465	2	J853-SD-CW-4606右	2442.5	23/F	1	2	T6
13	H-MA01-21	2215	20	J853-SD-CW-4607右	2192.5	10/F-15/F,17/F-22/F	10	2	T6
14	H-MA01-22	2272.5	2	J853-SD-CW-4607右	2342.5	26/F	1	2	T6
15	H-MA01-23	2365	4	J853-SD-CW-4607右	2342.5	16/F,25/F	2	2	T6
16	H-MA01-24	2465	2	J853-SD-CW-4607右	2442.5	23/F	1	2	T6
17	H-MA01-21	2215	13	J853-SD-CW-4603右	2192.5	7/F-15/F,17/F-22/F	13	1	T7
18	H-MA01-22	2272.5	1	J853-SD-CW-4603右	2342.5	26/F	1	1	T7
19	H-MA01-23	2365	2	J853-SD-CW-4603右	2342.5	16/F,25/F	2	1	T7
20	H-MA01-24	2465	1	J853-SD-CW-4603右	2442.5	23/F	1	1	T7
21	H-MA01-21	2215	13	J853-SD-CW-4604右	2192.5	7/F-15/F,17/F-22/F	13	1	T7
22	H-MA01-23	2365	1	J853-SD-CW-4604右	2342.5	16/F	1	1	T7
23	H-MA01-26	2165	1	J853-SD-CW-4604右	2192.5	23/F	1	1	T7
24	H-MA01-22	2272.5	1	J853-SD-CW-4608左	2342.5	26/F	1	1	T7
25	H-MA01-23	2365	1	J853-SD-CW-4608左	2342.5	25/F	1	1	T7
26	H-MA01-22	2272.5	2	J853-SD-CW-4609	2342.5	26/F	1	2	T7
		總數：	149						

名稱	企向收口鋁板(數據表)	制圖	方強	2023.05.08	修改			
材料	2mm鋁板	復核	謝永林	2023.05.20	日期			
顏色	EC-DG-D334232-ZD1(閃粉古銅)	批准	Daniel		圖號	H-MA01-21(1)		





美特鋁質有限公司  
MIDI Aluminium Fabricator Ltd.

拆圖見上頁

工程號 J-853 地盤 延坪道住宅

序號	物料編號	L	數量	位置	分格尺寸	樓層	樓層數	每層數量	座數
1	H-MB01-21	2215	28	J853-SD-CW-4602	2192.5	6/F-15/F,17/F-22/F	14	2	T6
2	H-MB01-22	2272.5	2	J853-SD-CW-4602	2342.5	26/F	1	2	T6
3	H-MB01-23	2365	6	J853-SD-CW-4602	2342.5	5/F,16/F,25/F	3	2	T6
4	H-MB01-24	2465	2	J853-SD-CW-4602	2442.5	23/F	1	2	T6
5	H-MB01-21	2215	13	J853-SD-CW-4603左	2192.5	7/F-15/F,17/F-22/F	13	1	T7
6	H-MB01-22	2272.5	1	J853-SD-CW-4603左	2342.5	26/F	1	1	T7
7	H-MB01-23	2365	2	J853-SD-CW-4603左	2342.5	16/F,25/F	2	1	T7
8	H-MB01-24	2465	1	J853-SD-CW-4603左	2442.5	23/F	1	1	T7
9	H-MB01-21	2215	13	J853-SD-CW-4604右	2192.5	7/F-15/F,17/F-22/F	13	1	T7
10	H-MB01-23	2365	1	J853-SD-CW-4604右	2342.5	16/F	1	1	T7
11	H-MB01-26	2165	1	J853-SD-CW-4604右	2192.5	23/F	1	1	T7
12	H-MB01-22	2272.5	1	J853-SD-CW-4608左	2342.5	26/F	1	1	T7
13	H-MB01-23	2365	1	J853-SD-CW-4608左	2342.5	25/F	1	1	T7
14	H-MB01-21	2215	11	J853-SD-CW-4608右	2192.5	9/F-15/F,17/F-22/F	11	1	T7
15	H-MB01-23	2365	1	J853-SD-CW-4608右	2342.5	16/F	1	1	T7
16	H-MB01-24	2465	1	J853-SD-CW-4608右	2442.5	23/F	1	1	T7
		總數：	85						

名稱	企向收口鋁板(數據表)	制圖	方強	2023.05.08	修改			
材料	2mm鋁板	復核	謝永林	2023.05.20	日期			
顏色	EC-DG-D334232-ZD1(閃粉古銅)	批准	Daniel		圖號	H-MB01-21(1)		

數據表見下頁

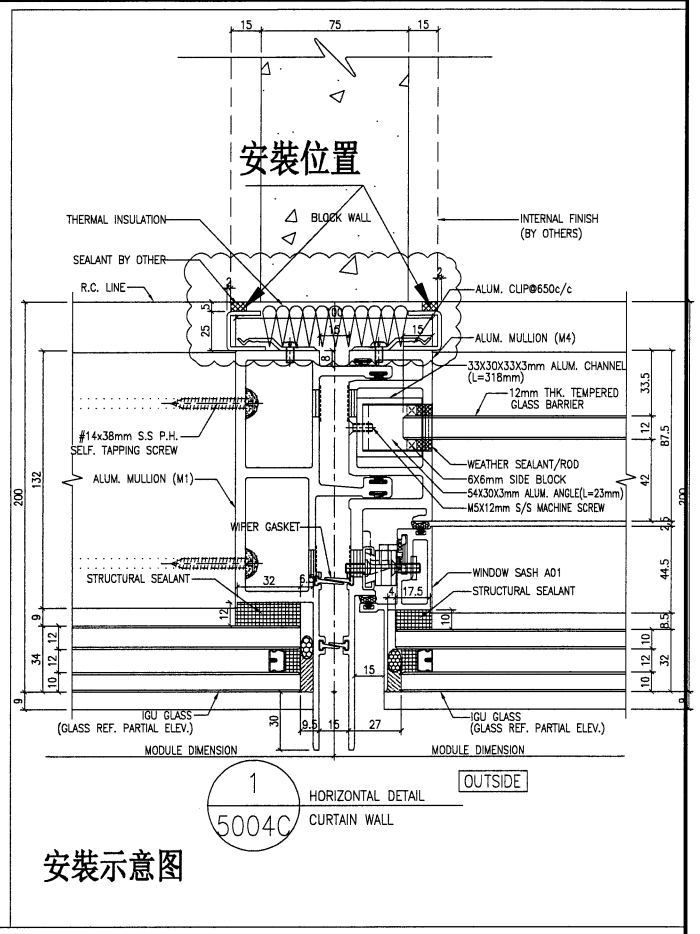
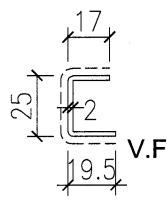
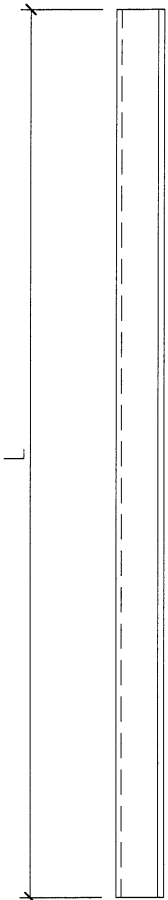

安裝示意图

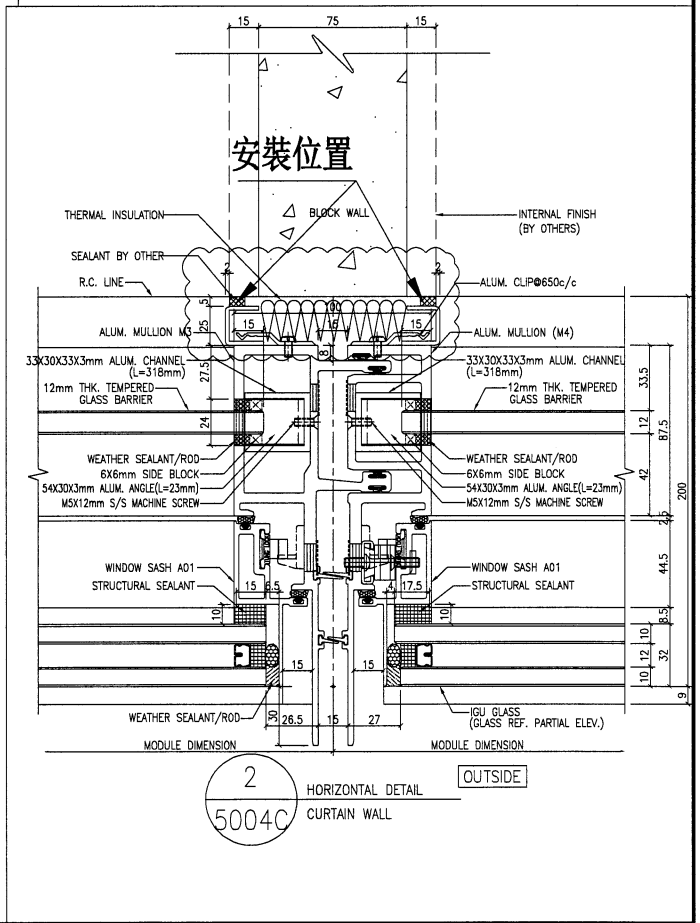

名稱	企向收口鋁板	制圖	方強	2023.05.08	修改		
材料	2mm鋁板	復核	謝永林	2023.05.20	日期		
顏色	EC-DG-D334232-ZD1(閃粉古銅)	批准	Daniel		圖號	H-MC01-21	



美特鋁質有限公司  
MIDI Aluminium Fabricator Ltd.

拆圖見上頁

工程號 J-853 地盤 延坪道住宅

序號	物料編號	L	數量	位置	分格尺寸	樓層	樓層數	每層數量	座數
1	H-MC01-21	2215	56	J853-SD-CW-4602	2192.5	6/F-15/F,17/F-22/F	14	4	T6
2	H-MC01-22	2272.5	4	J853-SD-CW-4602	2342.5	26/F	1	4	T6
3	H-MC01-23	2365	12	J853-SD-CW-4602	2342.5	5/F,16/F,25/F	3	4	T6
4	H-MC01-24	2465	4	J853-SD-CW-4602	2442.5	23/F	1	4	T6
5	H-MC01-21	2215	28	J853-SD-CW-4602A	2192.5	6/F-15/F,17/F-22/F	14	2	T6
6	H-MC01-22	2272.5	2	J853-SD-CW-4602A	2342.5	26/F	1	2	T6
7	H-MC01-23	2365	6	J853-SD-CW-4602A	2342.5	5/F,16/F,25/F	3	2	T6
8	H-MC01-24	2465	2	J853-SD-CW-4602A	2442.5	23/F	1	2	T6
9	H-MC01-21	2215	20	J853-SD-CW-4606右	2192.5	10/F-15/F,17/F-22/F	10	2	T6
10	H-MC01-22	2272.5	2	J853-SD-CW-4606右	2342.5	26/F	1	2	T6
11	H-MC01-23	2365	4	J853-SD-CW-4606右	2342.5	16/F,25/F	2	2	T6
12	H-MC01-24	2465	2	J853-SD-CW-4606右	2442.5	23/F	1	2	T6
13	H-MC01-21	2215	26	J853-SD-CW-4603左	2192.5	7/F-15/F,17/F-22/F	13	2	T7
14	H-MC01-22	2272.5	2	J853-SD-CW-4603左	2342.5	26/F	1	2	T7
15	H-MC01-23	2365	4	J853-SD-CW-4603左	2342.5	16/F,25/F	2	2	T7
16	H-MC01-24	2465	2	J853-SD-CW-4603左	2442.5	23/F	1	2	T7
17	H-MC01-21	2215	26	J853-SD-CW-4603右	2192.5	7/F-15/F,17/F-22/F	13	2	T7
18	H-MC01-22	2272.5	2	J853-SD-CW-4603右	2342.5	26/F	1	2	T7
19	H-MC01-23	2365	4	J853-SD-CW-4603右	2342.5	16/F,25/F	2	2	T7
20	H-MC01-24	2465	2	J853-SD-CW-4603右	2442.5	23/F	1	2	T7
21	H-MC01-21	2215	26	J853-SD-CW-4604右	2192.5	7/F-15/F,17/F-22/F	13	2	T7
22	H-MC01-23	2365	2	J853-SD-CW-4604右	2342.5	16/F	1	2	T7
23	H-MC01-26	2165	2	J853-SD-CW-4604右	2192.5	23/F	1	2	T7
24	H-MC01-22	2272.5	2	J853-SD-CW-4608左	2342.5	26/F	1	2	T7
25	H-MC01-23	2365	2	J853-SD-CW-4608左	2342.5	25/F	1	2	T7
26	H-MC01-21	2215	11	J853-SD-CW-4608右	2192.5	9/F-15/F,17/F-22/F	11	1	T7
27	H-MC01-23	2365	1	J853-SD-CW-4608右	2342.5	16/F	1	1	T7
28	H-MC01-24	2465	1	J853-SD-CW-4608右	2442.5	23/F	1	1	T7
		總數：	257						

名稱	企向收口鋁板(數據表)	制圖	方強	2023.05.08	修改			
材料	2mm鋁板	復核	謝永林	2023.05.20	日期			
顏色	EC-DG-D334232-ZD1(閃粉古銅)	批准	Daniel		圖號	H-MC01-21(1)		

18



美特鋁質有限公司  
MIDI Aluminium Fabricator Ltd.

工程號

J-853

地盤

延坪道住宅

數據表見下頁

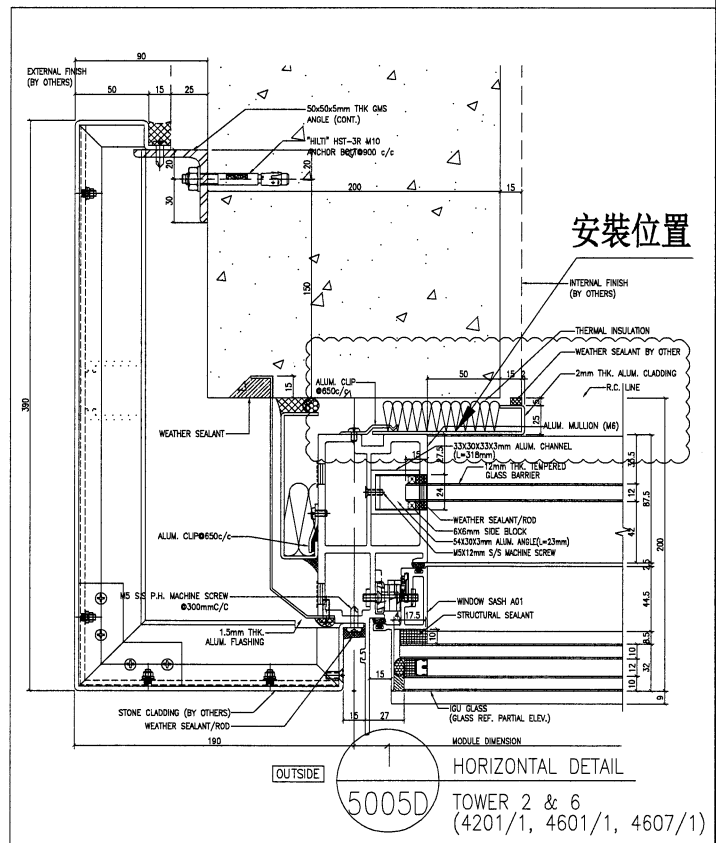
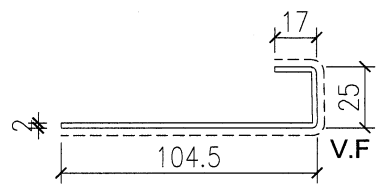
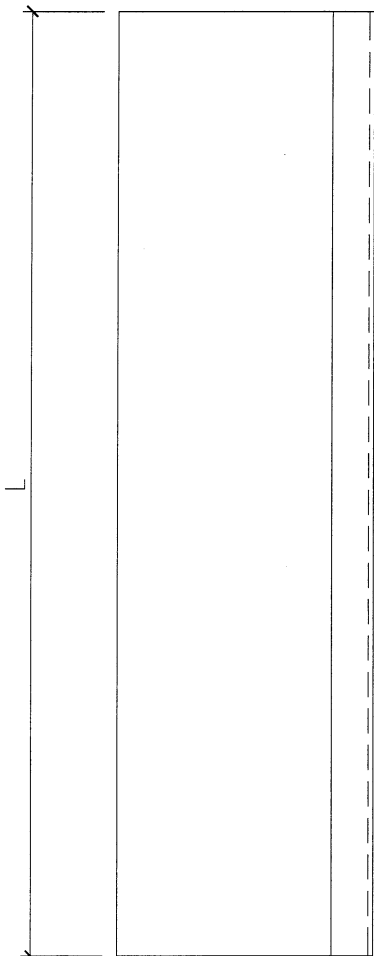

安裝示意图

5005D

TOWER 2 & 6  
(4201/1, 4601/1, 4607/1)

名稱	企向收口鋁板	制圖	方強	2023.05.08	修改		
材料	2mm鋁板	復核	謝永林	2023.05.20	日期		
顏色	EC-DG-D334232-ZD1(閃粉古銅)	批准	Daniel		圖號	H-MD01-21	



美特鋁質有限公司  
MIDI Aluminium Fabricator Ltd.

拆圖見上頁

工程號 J-853 地盤 延坪道住宅

序號	物料編號	L	數量	位置	分格尺寸	樓層	樓層數	每層數量	座數
1	H-MD01-21	2215	14	J853-SD-CW-4601左	2192.5	6/F-15/F,17/F-22/F	14	1	T6
2	H-MD01-22	2272.5	1	J853-SD-CW-4601左	2342.5	26/F	1	1	T6
3	H-MD01-23	2365	3	J853-SD-CW-4601左	2342.5	5/F,16/F,25/F	3	1	T6
4	H-MD01-24	2465	1	J853-SD-CW-4601左	2442.5	23/F	1	1	T6
5	H-MD01-21	2215	10	J853-SD-CW-4606左	2192.5	10/F-15/F,17/F-22/F	10	1	T6
6	H-MD01-22	2272.5	1	J853-SD-CW-4606左	2342.5	26/F	1	1	T6
7	H-MD01-23	2365	2	J853-SD-CW-4606左	2342.5	16/F,25/F	2	1	T6
8	H-MD01-24	2465	1	J853-SD-CW-4606左	2442.5	23/F	1	1	T6
9	H-MD01-21	2215	10	J853-SD-CW-4607左	2192.5	10/F-15/F,17/F-22/F	10	1	T6
10	H-MD01-22	2272.5	1	J853-SD-CW-4607左	2342.5	26/F	1	1	T6
11	H-MD01-23	2365	2	J853-SD-CW-4607左	2342.5	16/F,25/F	2	1	T6
12	H-MD01-24	2465	1	J853-SD-CW-4607左	2442.5	23/F	1	1	T6
13	H-MD01-21	2215	13	J853-SD-CW-4604左	2192.5	7/F-15/F,17/F-22/F	13	1	T7
14	H-MD01-23	2365	1	J853-SD-CW-4604左	2342.5	16/F	1	1	T7
15	H-MD01-29	2270	1	J853-SD-CW-4604左	2192.5	23/F	1	1	T7
16	H-MD01-21	2215	13	J853-SD-CW-4605	2192.5	7/F-15/F,17/F-22/F	13	1	T7
17	H-MD01-23	2365	1	J853-SD-CW-4605	2342.5	16/F	1	1	T7
18	H-MD01-24	2465	1	J853-SD-CW-4605	2442.5	23/F	1	1	T7
19	H-MD01-25	2060.5	1	J853-SD-CW-4605	2142.5	25/F	1	1	T7
		總數：	78						

名稱	企向收口鋁板(數據表)	制圖	方強	2023.05.08	修改			
材料	2mm鋁板	復核	謝永林	2023.05.20	日期			
顏色	EC-DG-D334232-ZD1(閃粉古銅)	批准	Daniel		圖號	H-MD01-21(1)		

數據表見下頁

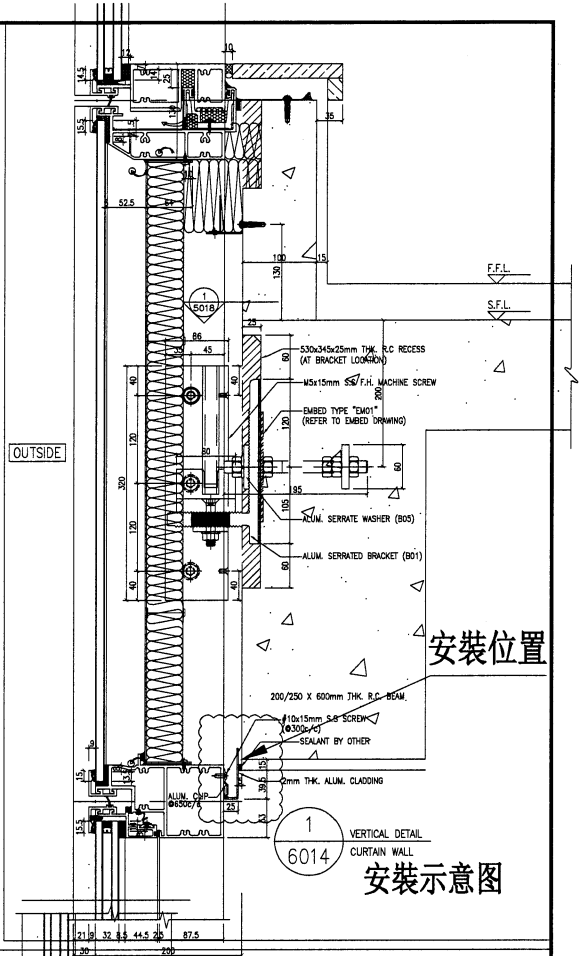
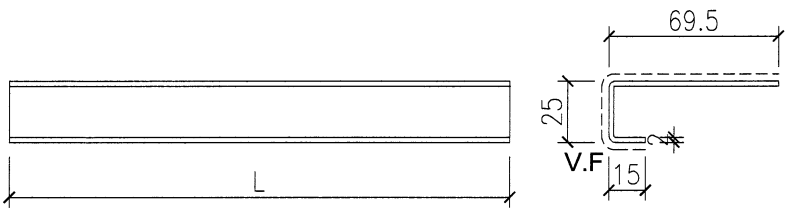

安裝示意图

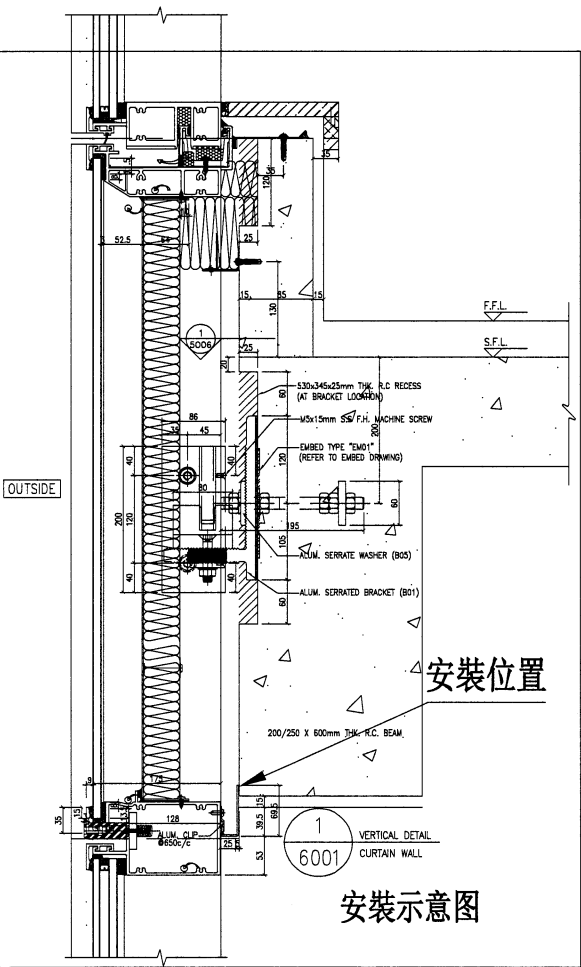

安裝示意图

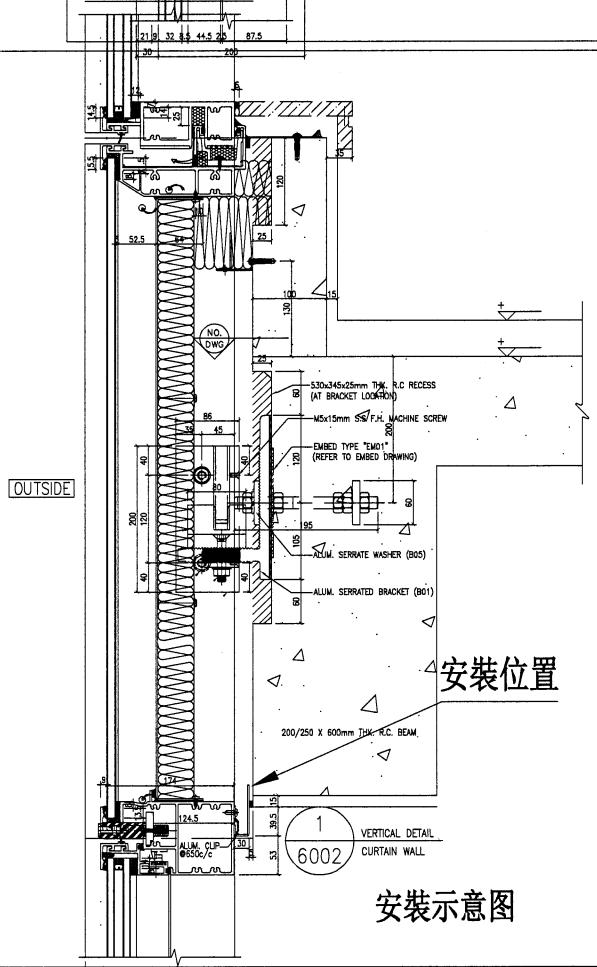

安裝示意图

名稱	橫向收口鋁板	制圖	方強	2023.05.08	修改		
材料	2mm鋁板	復核	謝永林	2023.05.20	日期		
顏色	EC-DG-D334232-ZD1(閃粉古銅)	批准	Daniel		圖號	W-MA01-601	



美特鋁質有限公司  
MIDI Aluminium Fabricator Ltd.

拆圖見上頁

工程號 J-853 地盤 延坪道住宅

序號	物料編號	L	數量	位置	分格尺寸	樓層	樓層數	每層數量	座數
1	W-MA01-601	1693	18	J853-SD-CW-4601左	1725	5/F-25/F	18	1	T6
2	W-MA01-602	1895	18	J853-SD-CW-4601右	1725	5/F-25/F	18	1	T6
3	W-MA01-604	2493	36	J853-SD-CW-4602	2477.5	5/F-25/F	18	2	T6
4	W-MA01-605	1893	18	J853-SD-CW-4602A	1862.5	5/F-25/F	18	1	T6
5	W-MA01-606	1768	18	J853-SD-CW-4602A	1737.5	5/F-25/F	18	1	T6
6	W-MA01-607	1168	13	J853-SD-CW-4606左	1200	10/F-25/F	13	1	T6
7	W-MA01-608	1818	13	J853-SD-CW-4606右	1787.5	10/F-25/F	13	1	T6
8	W-MA01-609	1843	13	J853-SD-CW-4606右	1812.5	10/F-25/F	13	1	T6
9	W-MA01-607	1168	13	J853-SD-CW-4607左	1200	10/F-25/F	13	1	T6
10	W-MA01-610	1495	13	J853-SD-CW-4607右	1325	10/F-25/F	13	1	T6
11	W-MA01-701	2168	16	J853-SD-CW-4603左	2152.5	7/F-25/F	16	1	T7
12	W-MA01-703	1918	16	J853-SD-CW-4603右	1887.5	7/F-25/F	16	1	T7
13	W-MA01-704	2193	16	J853-SD-CW-4603右	2162.5	7/F-25/F	16	1	T7
14	W-MA01-706	2293	14	J853-SD-CW-4604右	2262.5	7/F-22/F	14	1	T7
15	W-MA01-707	2518	14	J853-SD-CW-4604右	2502.5	7/F-22/F	14	1	T7
16	W-MA01-711	718	1	J853-SD-CW-4608左	702.5	25/F	1	1	T7
17	W-MA01-712	1518	1	J853-SD-CW-4608左	1487.5	25/F	1	1	T7
18	W-MA01-713	2918	13	J853-SD-CW-4608右	2902.5	9/F-23/F	13	1	T7
19	W-MA01-714	1465	13	J853-SD-CW-4608右	1537.5	9/F-23/F	13	1	T7
20	W-MA01-715	1750	1	J853-SD-CW-4609	1650	25/F	1	1	T7
21	W-MA01-716	2535	1	J853-SD-CW-4609	2535	25/F	1	1	T7
22	W-MA01-717	2100	1	J853-SD-CW-4609	2100	25/F	1	1	T7
23	W-MA01-718	2715	1	J853-SD-CW-4609	2615	25/F	1	1	T7
		總數：	281						

名稱	橫向收口鋁板(數據表)	制圖	方強	2023. 05. 08	修改			
材料	2mm鋁板	復核	謝永林	2023. 05. 20	日期			
顏色	EC-DG-D334232-ZD1(閃粉古銅)	批准	Daniel		圖號	W-MA01-601(1)		



美特鋁質 有限公司  
MIDI Aluminium Fabricator Ltd.

數據表見下頁

工程號	J-853	地盤	延坪道住宅
-----	-------	----	-------

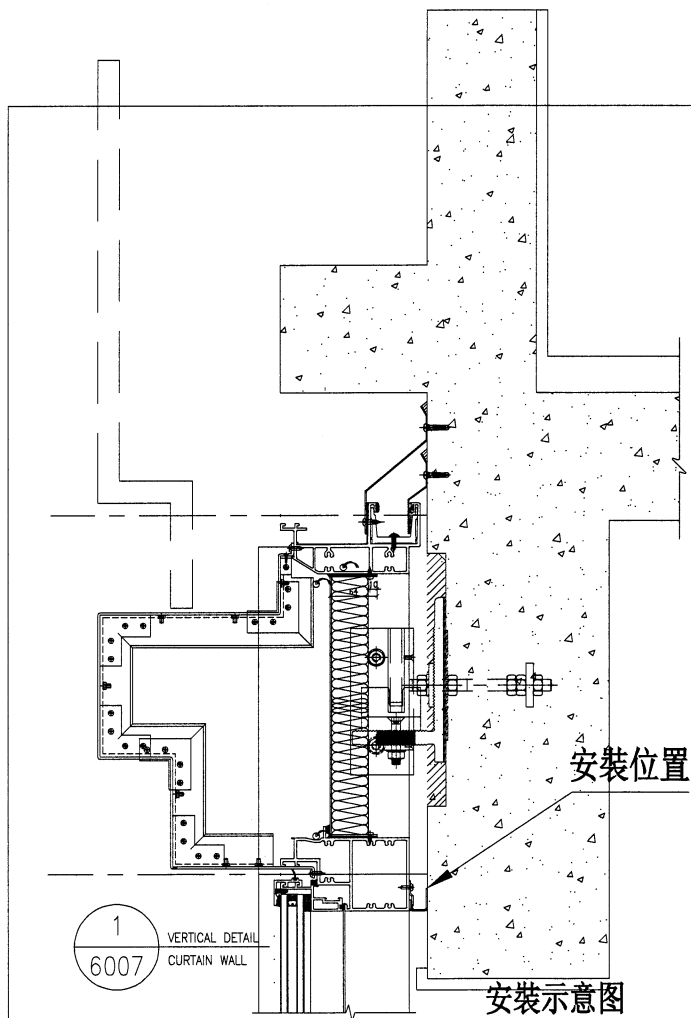
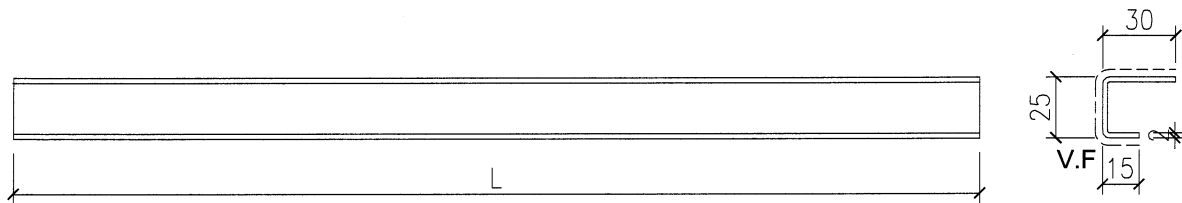

名稱	橫向收口鋁板	制圖	方強	2023.05.08	修改			
材料	2mm鋁板	復核	謝永林	2023.05.20	日期			
顏色	EC-DG-D334232-ZD1(閃粉古銅)	批准	Daniel		圖號	W-MB01-601		



美特鋁質有限公司  
MIDI Aluminium Fabricator Ltd.

拆圖見上頁

工程號 J-853 地盤 延坪道住宅

序號	物料編號	L	數量	位置	分格尺寸	樓層	樓層數	每層數量	座數
1	W-MB01-601	1693	1	J853-SD-CW-4601左	1725	26/F	1	1	T6
2	W-MB01-602	1895	1	J853-SD-CW-4601右	1725	26/F	1	1	T6
3	W-MB01-604	2493	2	J853-SD-CW-4602	2477.5	26/F	1	2	T6
4	W-MB01-605	1893	1	J853-SD-CW-4602A	1862.5	26/F	1	1	T6
5	W-MB01-606	1768	1	J853-SD-CW-4602A	1737.5	26/F	1	1	T6
6	W-MB01-607	1168	1	J853-SD-CW-4606左	1200	26/F	1	1	T6
7	W-MB01-608	1818	1	J853-SD-CW-4606右	1787.5	26/F	1	1	T6
8	W-MB01-609	1843	1	J853-SD-CW-4606右	1812.5	26/F	1	1	T6
9	W-MB01-607	1168	1	J853-SD-CW-4607左	1200	26/F	1	1	T6
10	W-MB01-610	1495	1	J853-SD-CW-4607右	1325	26/F	1	1	T6
11	W-MB01-701	2168	1	J853-SD-CW-4603左	2152.5	26/F	1	1	T7
12	W-MB01-703	1918	1	J853-SD-CW-4603右	1887.5	26/F	1	1	T7
13	W-MB01-704	2193	1	J853-SD-CW-4603右	2162.5	26/F	1	1	T7
14	W-MB01-711	718	1	J853-SD-CW-4608左	702.5	26/F	1	1	T7
15	W-MB01-712	1518	1	J853-SD-CW-4608左	1487.5	26/F	1	1	T7
16	W-MB01-719	1735	1	J853-SD-CW-4609	1650	26/F	1	1	T7
17	W-MB01-720	2535	1	J853-SD-CW-4609	2535	26/F	1	1	T7
18	W-MB01-721	2100	1	J853-SD-CW-4609	2100	26/F	1	1	T7
19	W-MB01-722	2700	1	J853-SD-CW-4609	2615	26/F	1	1	T7
		總數：	20						

名稱	橫向收口鋁板(數據表)	制圖	方強	2023.05.08	修改			
材料	2mm鋁板	復核	謝永林	2023.05.20	日期			
顏色	EC-DG-D334232-ZD1(閃粉古銅)	批准	Daniel		圖號	W-MB01-601(1)		

**美特鋁質有限公司**  
MIDI Aluminium Fabricator Ltd.

工程號	J-853	地盤	延坪道住宅
-----	-------	----	-------

序號	物料編號	L	數量	位置	分格尺寸	樓層	樓層數	每層數量	座數
1	W-MD01-706	2293	1	J853-SD-CW-4604右	2262.5	23/F	1	1	T7
2	W-MD01-707	2518	1	J853-SD-CW-4604右	2502.5	23/F	1	1	T7
		總數：	2						

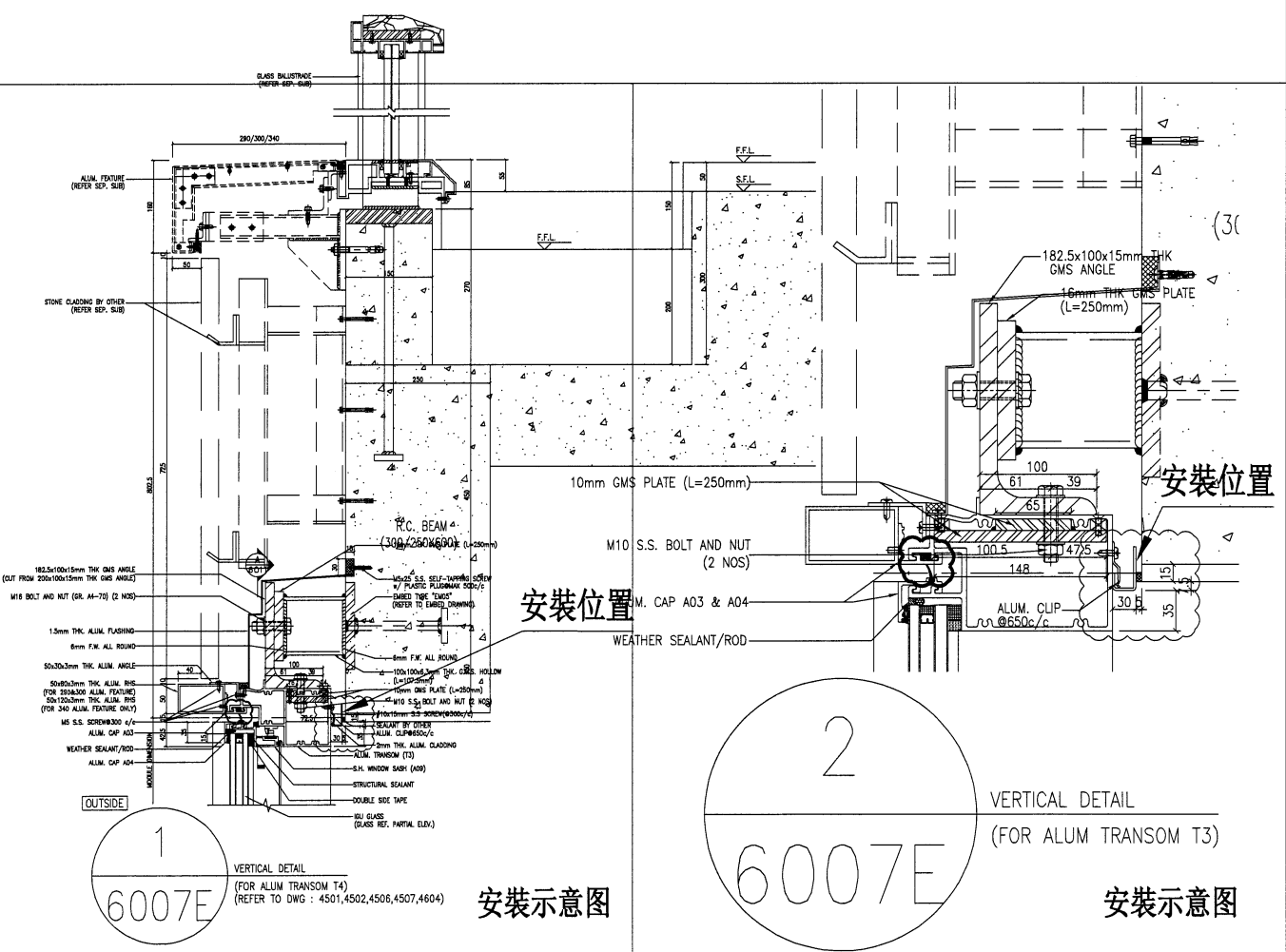
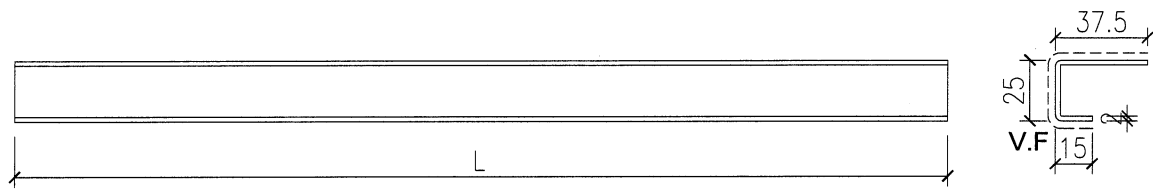

名稱	橫向收口鋁板	制圖	方強	2023.05.08	修改			
材料	2mm鋁板	復核	謝永林	2023.05.20	日期			
顏色	EC-DG-D334232-ZD1(閃粉古銅)	批准	Daniel		圖號	W-MD01-706		





美特鋁質有限公司  
MIDI Aluminium Fabricator Ltd.

工程號 J-853 地盤 延坪道住宅

序號	物料編號	L	數量	位置	分格尺寸	樓層	樓層數	每層數量	座數	
1	W-MAFK01L-603	718	18	J853-SD-CW-4602	642.5	5/F-25/F	18	1	T6	
2	W-MAFK01L-705	798	14	J853-SD-CW-4604左	785	7/F-22/F	14	1	T7	
總數：			32							

端部封口

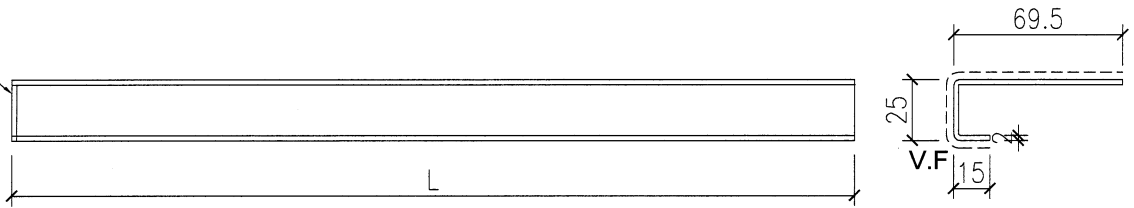

封口示意图

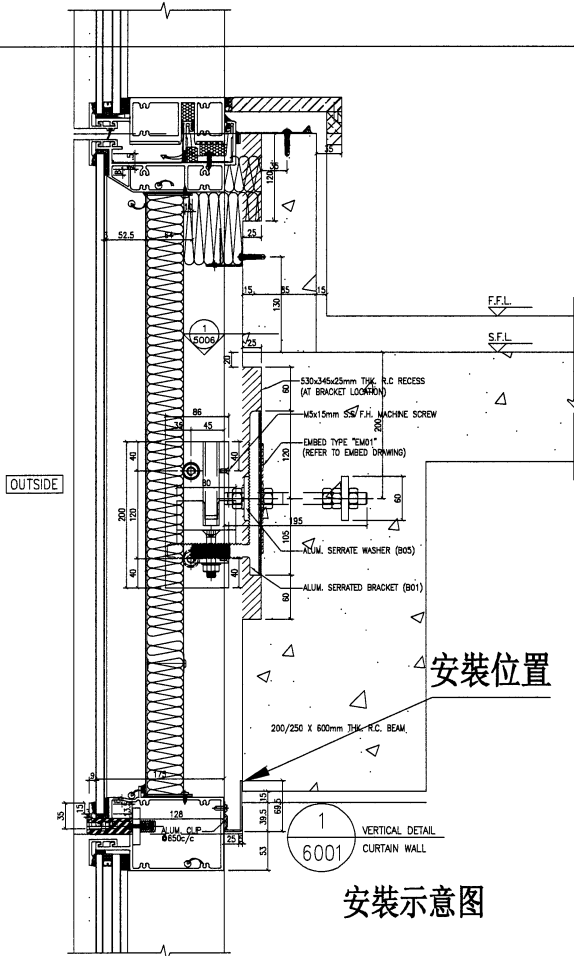
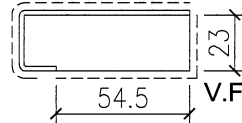

安裝示意图

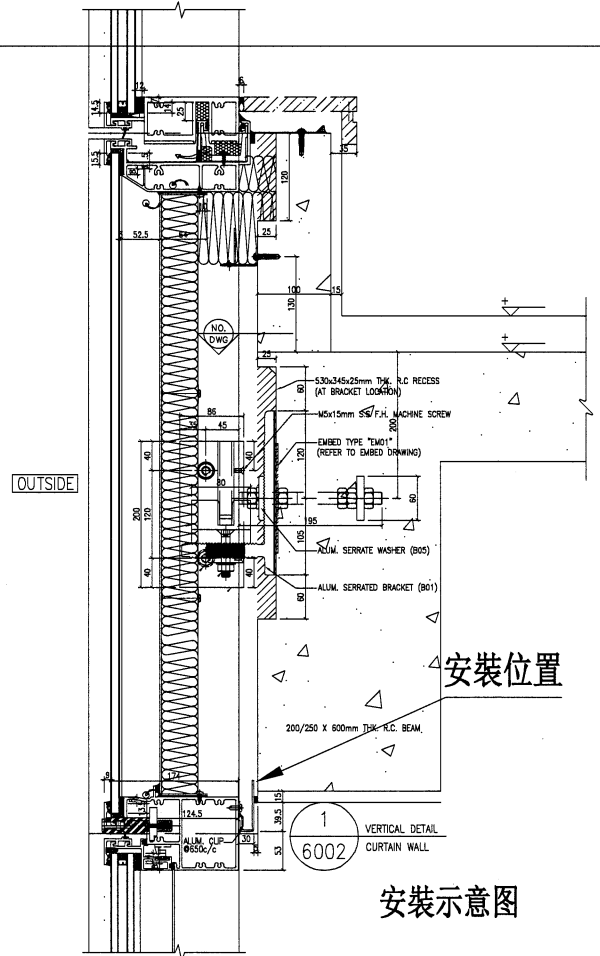

安裝示意图

名稱	橫向收口鋁板	制圖	方強	2023.05.08	修改		
材料	2mm鋁板	復核	謝永林	2023.05.20	日期		
顏色	EC-DG-D334232-ZD1(閃粉古銅)	批准	Daniel		圖號	W-MAFK01L-603	



美特鋁質有限公司  
MIDI Aluminium Fabricator Ltd.

工程號 J-853 地盤 延坪道住宅

序號	物料編號	L	數量	位置	分格尺寸	樓層	樓層數	每層數量	座數
1	W-MAFK01R-603	718	18	J853-SD-CW-4602	642.5	5/F-25/F	18	1	T6
2	W-MAFK01R-702	718	16	J853-SD-CW-4603左	642.5	7/F-25/F	16	1	T7
總數：			34						

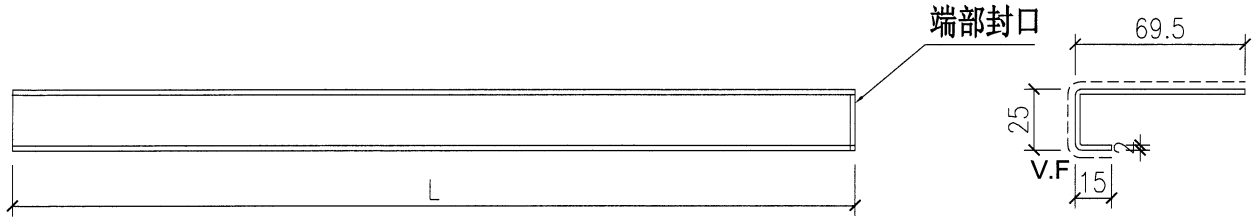

封口示意图

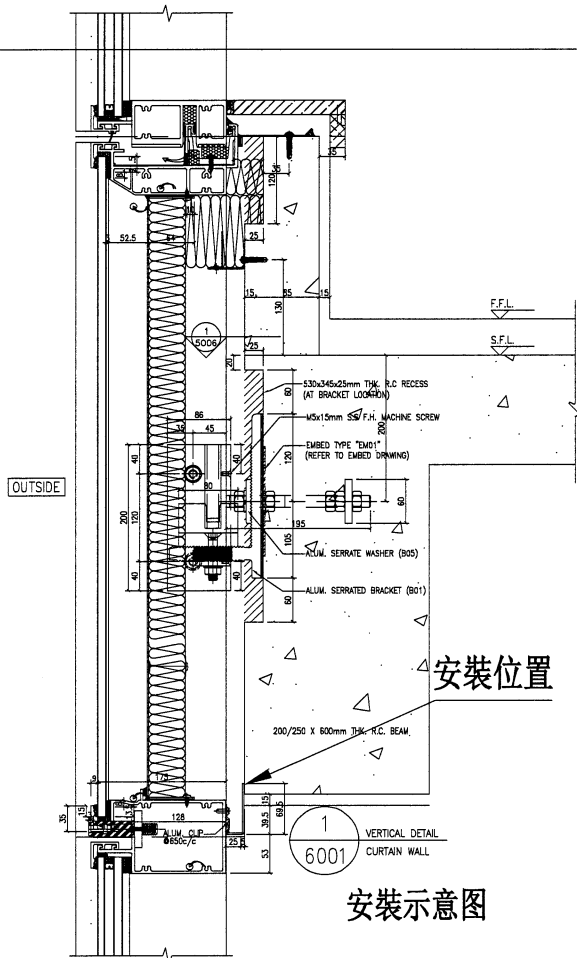

安裝示意图

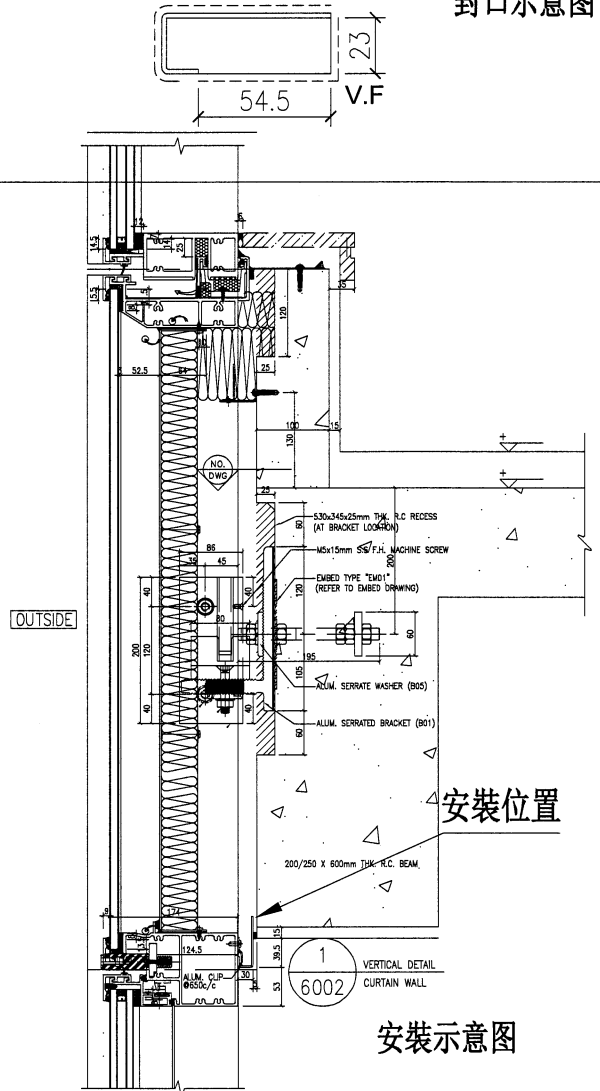

安裝示意图

名稱	橫向收口鋁板	制圖	方強	2023.05.08	修改			
材料	2mm鋁板	復核	謝永林	2023.05.20	日期			
顏色	EC-DG-D334232-ZD1(閃粉古銅)	批准	Daniel		圖號	W-MAFK01R-603		



美特鋁質有限公司  
MIDI Aluminium Fabricator Ltd.

工程號 J-853 地盤 延坪道住宅

序號	物料編號	L	數量	位置	分格尺寸	樓層	樓層數	每層數量	座數
1	W-MBFK01L-603	718	1	J853-SD-CW-4602	642.5	26/F	1	1	T6

端部封口

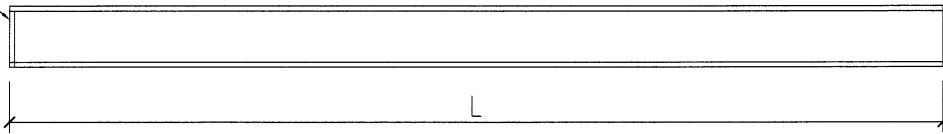

封口示意图

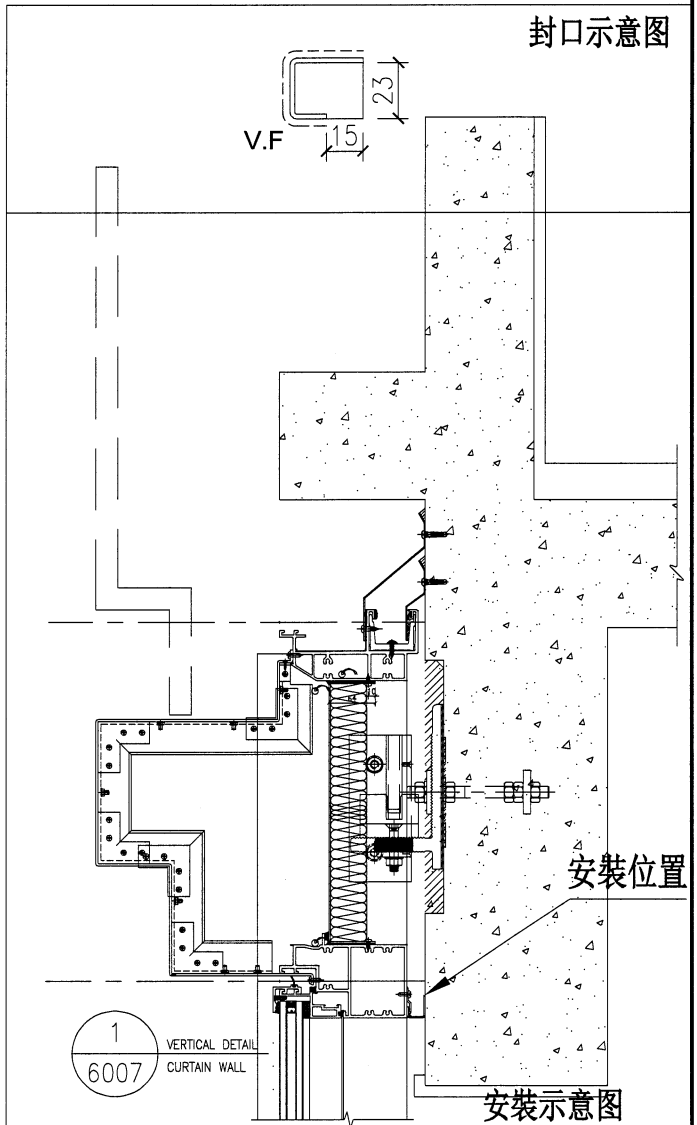
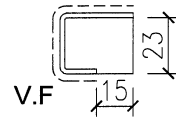

1  
6007  
VERTICAL DETAIL  
CURTAIN WALL

安裝示意图

名稱	橫向收口鋁板	制圖	方強	2023. 05. 08	修改			
材料	2mm鋁板	復核	謝永林	2023. 05. 20	日期			
顏色	EC-DG-D334232-ZD1(閃粉古銅)	批准	Daniel		圖號	W-MBFK01L-603		



美特鋁質有限公司  
MIDI Aluminium Fabricator Ltd.

工程號 J-853 地盤 延坪道住宅

序號	物料編號	L	數量	位置	分格尺寸	樓層	樓層數	每層數量	座數	
1	W-MBFK01R-603	718	1	J853-SD-CW-4602	642.5	26/F	1	1	T6	
2	W-MBFK01R-702	718	1	J853-SD-CW-4603左	642.5	26/F	1	1	T7	
		總數:	2							

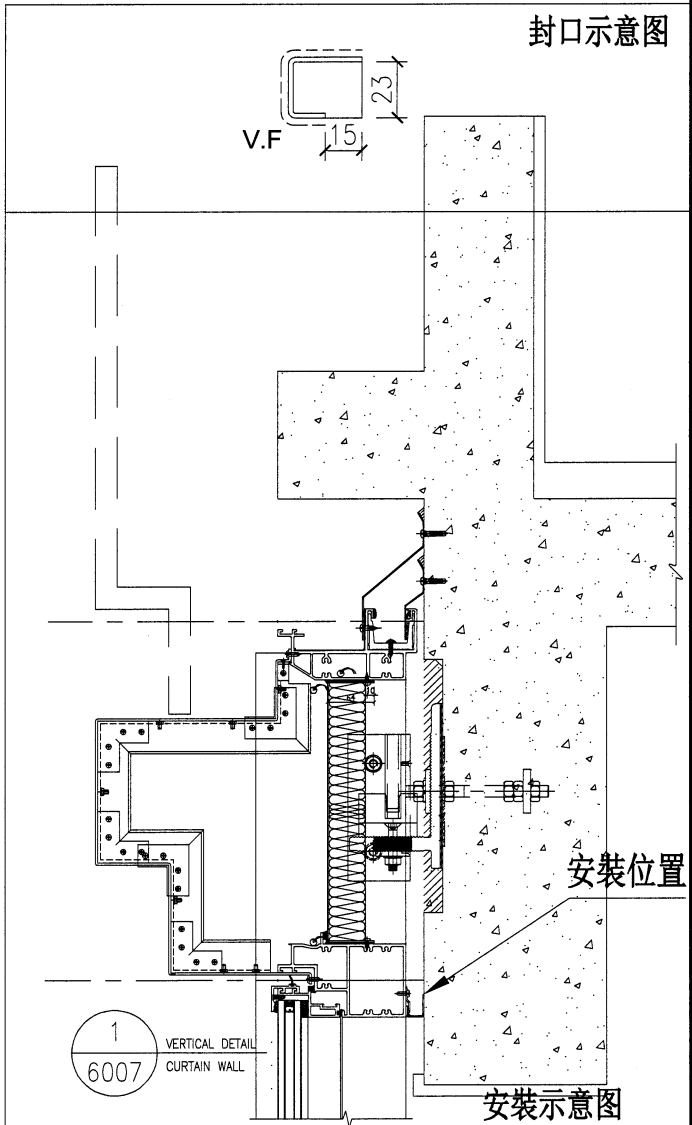
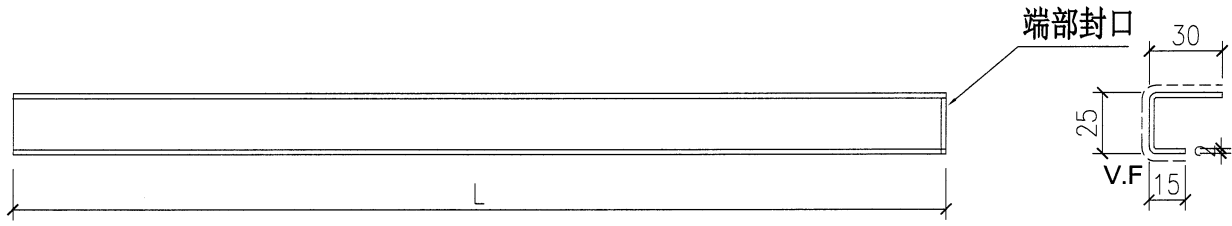

名稱	橫向收口鋁板	制圖	方強	2023.05.08	修改				
材料	2mm鋁板	復核	謝永林	2023.05.20	日期				
顏色	EC-DG-D334232-ZD1(閃粉古銅)	批准	Daniel		圖號	W-MBFK01R-603			



美特鋁質有限公司  
MIDI Aluminium Fabricator Ltd.

已預長, 地盤復尺

工程號 J-853 地盤 延坪道住宅

序號	物料編號	L	數量	位置	分格尺寸	樓層	樓層數	每層數量	座數
1	W-MEFK01L-705	815	1	J853-SD-CW-4604左	785	23/F	1	1	T7

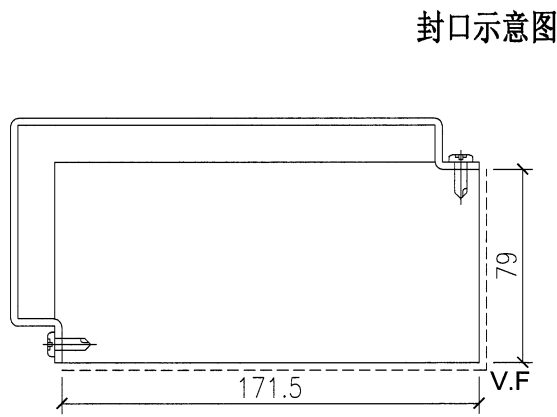
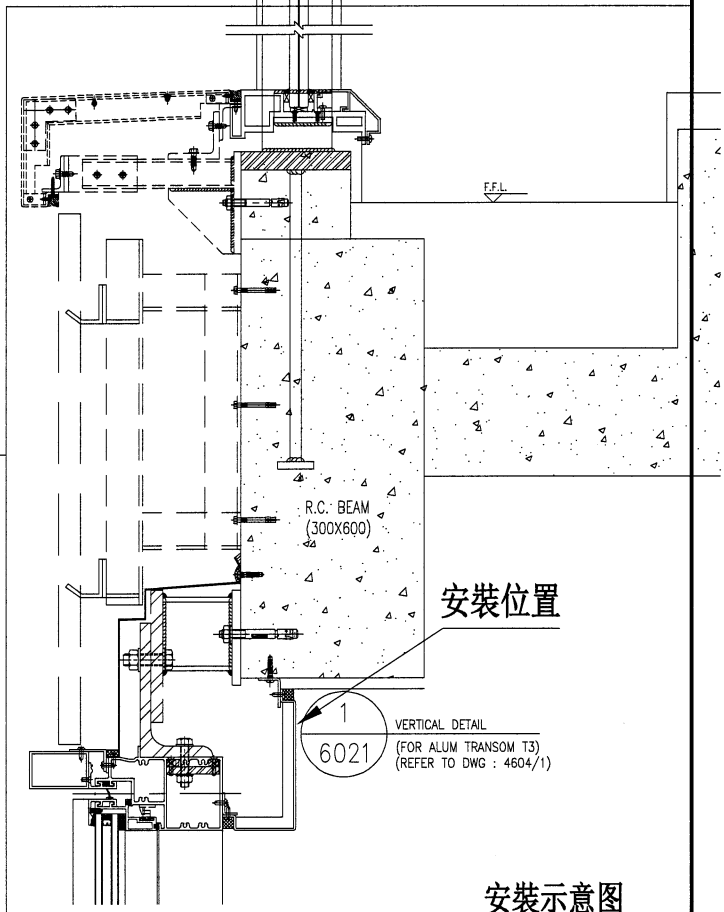
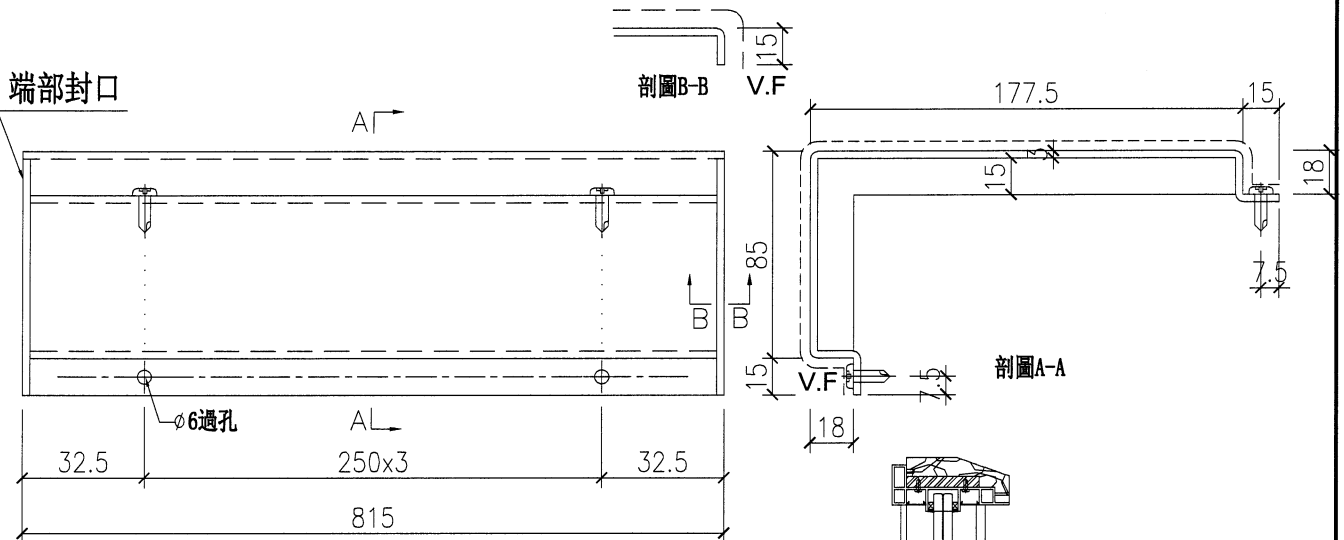

名稱	橫向收口鋁板	制圖	方強	2023.05.08	修改			
材料	3mm鋁板	復核	謝永林	2023.05.20	日期			
顏色	EC-DG-D334232-ZD1(閃粉古銅)	批准	Daniel		圖號	W-MEFK01L-705		

31



美特鋁質 有限公司  
MIDI Aluminium Fabricator Ltd.

工程號 J-853 地盤 延坪道住宅

序號	物料編號	L	數量	位置	分格尺寸	樓層	樓層數	每層數量	座數
1	W-MEFK01L-705a	800	1	J853-SD-CW-4604左	785	23/F	1	1	T7

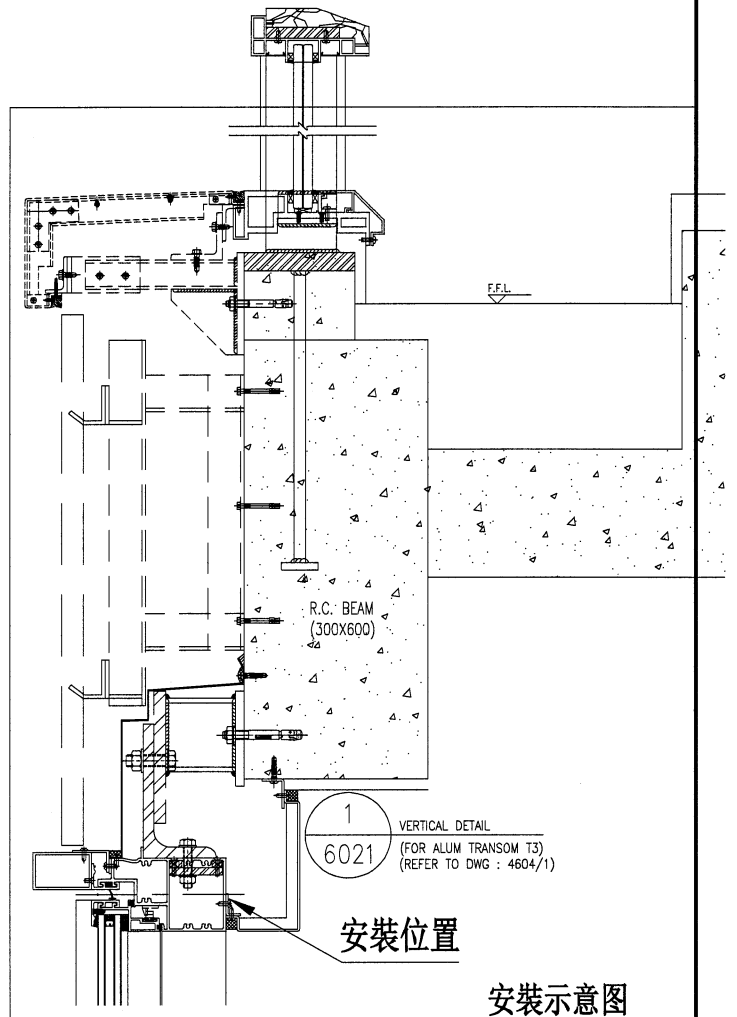
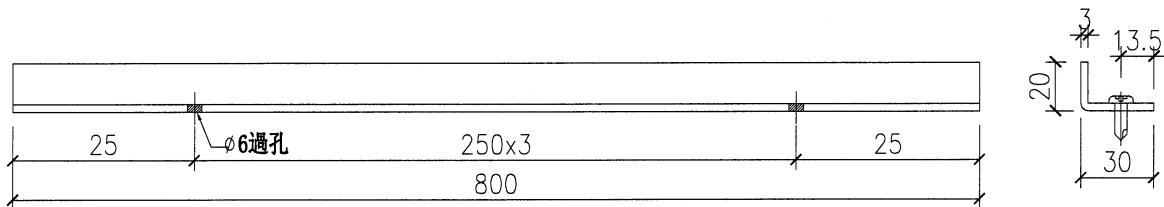

名稱	橫向收口鋁板	制圖	方強	2023. 05. 08	修改			
材料	3mm鋁板	復核	謝永林	2023. 05. 20	日期			
顏色	鉻化	批准	Daniel		圖號	W-MEFK01L-705a		

32



美特鋁質有限公司  
MIDI Aluminium Fabricator Ltd.

工程號 J-853 地盤 延坪道住宅

序號	物料編號	L	數量	位置	分格尺寸	樓層	樓層數	每層數量	座數
1	W-MEFK01L-705b	800	1	J853-SD-CW-4604左	785	23/F	1	1	T7

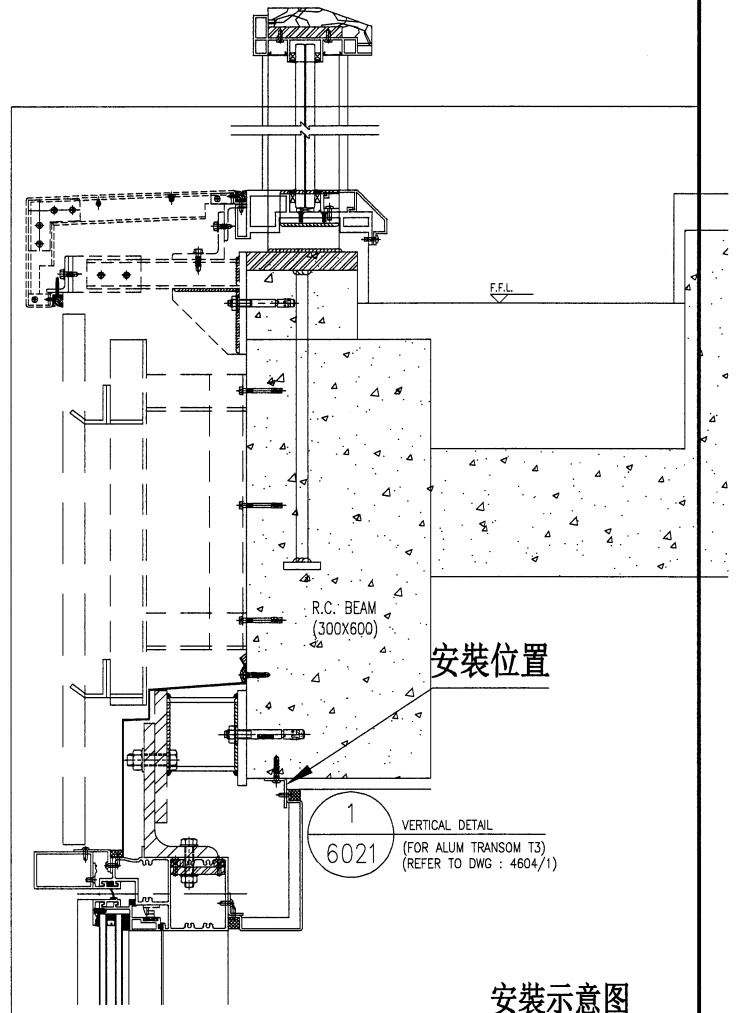
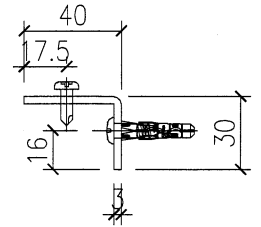
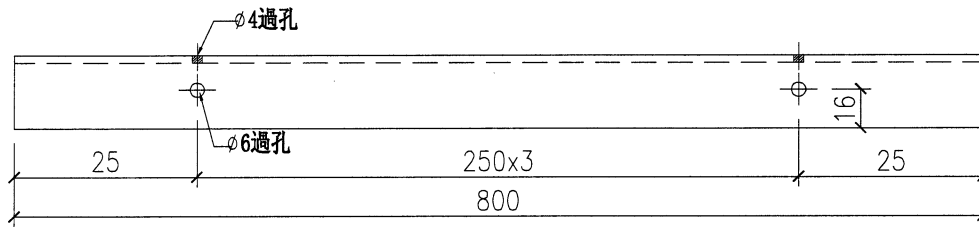

安裝示意图

名稱	橫向收口鋁板	制圖	方強	2023.05.08	修改			
材料	3mm鋁板	復核	謝永林	2023.05.20	日期			
顏色	鉻化	批准	Daniel		圖號	W-MEFK01L-705b		



美特鋁質有限公司  
MIDI Aluminium Fabricator Ltd.

工程號 J-853 地盤 延坪道住宅

序號	物料編號	L	數量	位置	分格尺寸	樓層	樓層數	每層數量	座數
1	W-MA01-708	2235	15	J853-SD-CW-4605	2325	7/F-23/F	15	1	T7

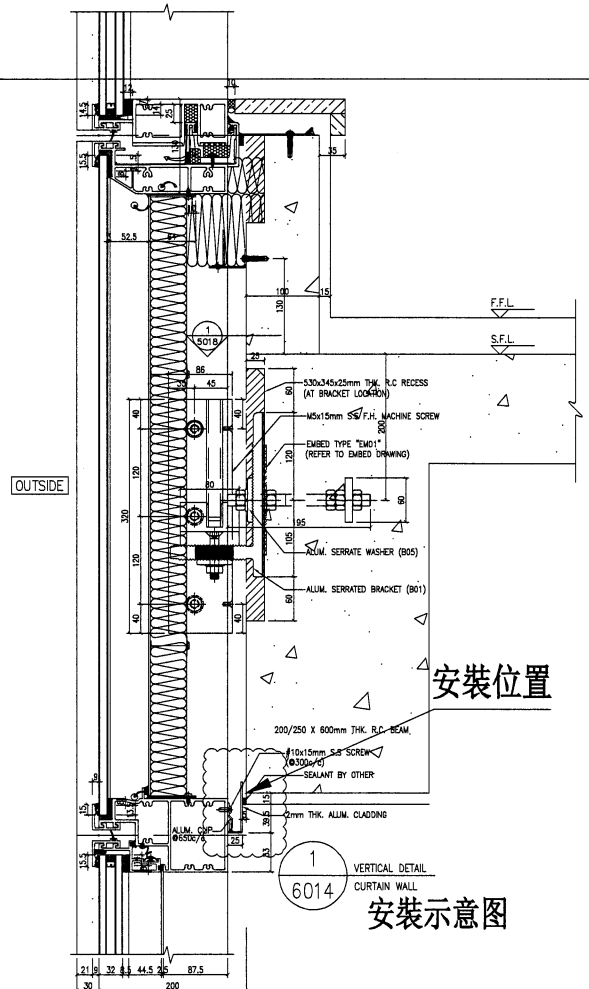
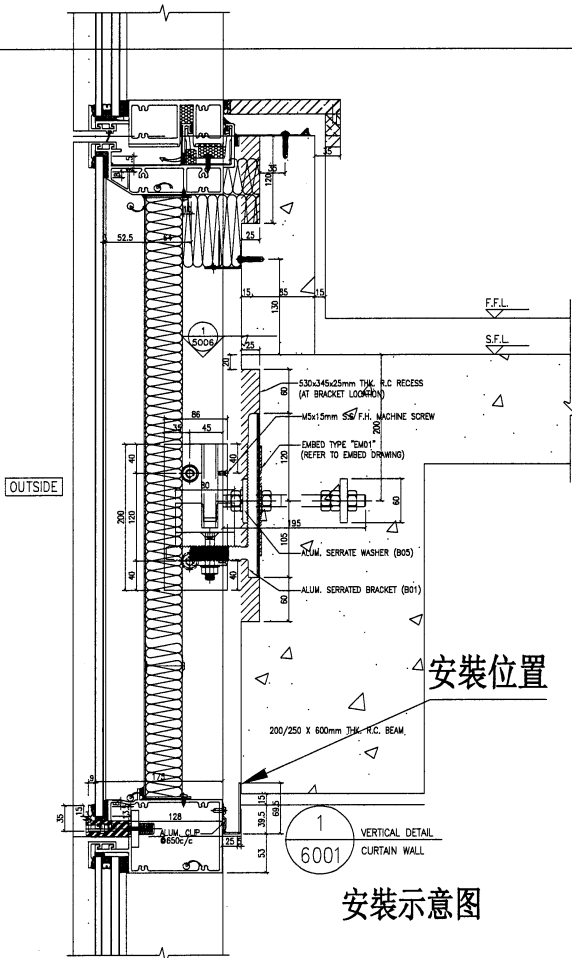
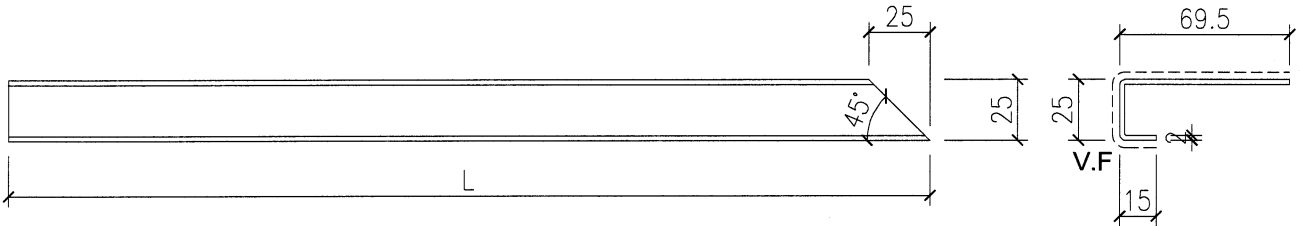

名稱	轉角橫向收口鋁板	制圖	方強	2023.05.08	修改				
材料	2mm鋁板	復核	謝永林	2023.05.20	日期				
顏色	EC-DG-D334232-ZD1(閃粉古銅)	批准	Daniel		圖號	W-MA01-708			



美特鋁質有限公司  
MIDI Aluminium Fabricator Ltd.

工程號 J-853 地盤 延坪道住宅

序號	物料編號	L	數量	位置	分格尺寸	樓層	樓層數	每層數量	座數
1	W-MA01-709	808	15	J853-SD-CW-4605	1100	7/F-23/F	15	1	T7

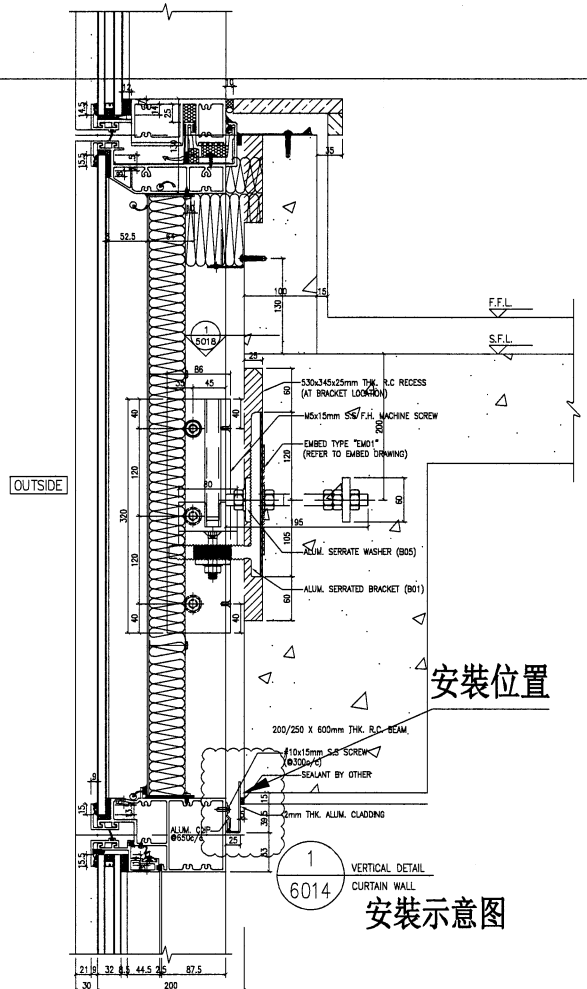
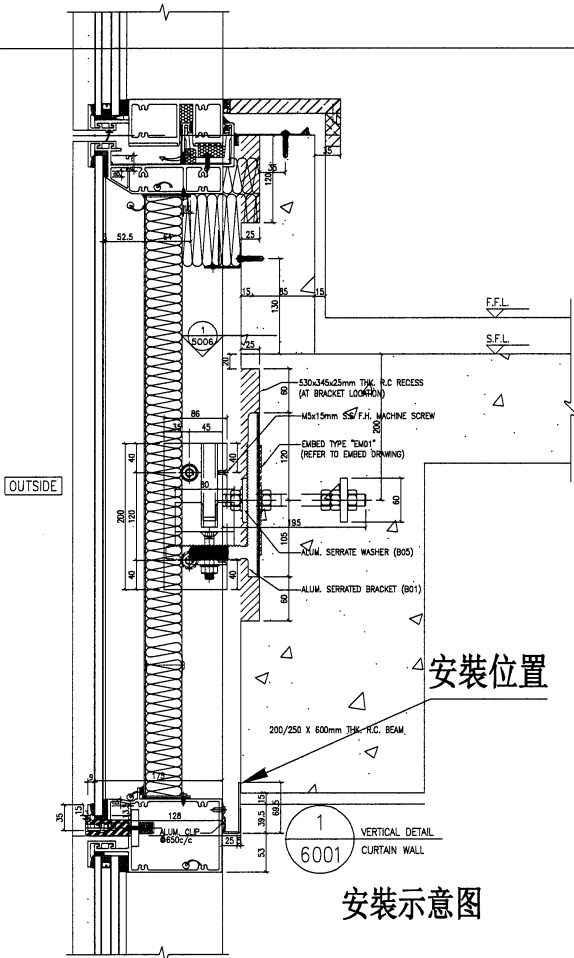
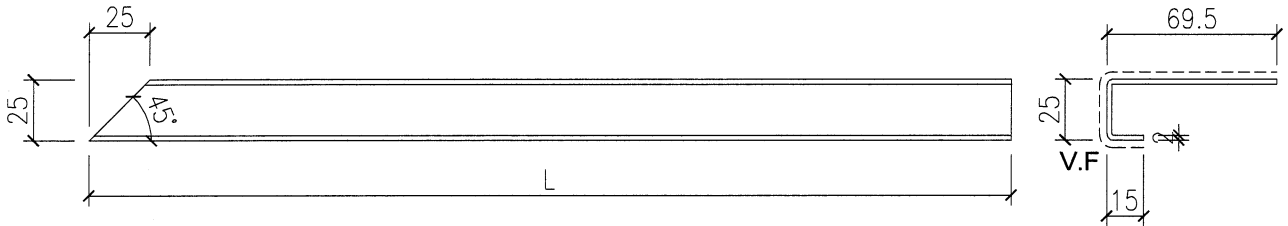

名稱	轉角橫向收口鋁板	制圖	方強	2023.05.08	修改				
材料	2mm鋁板	復核	謝永林	2023.05.20	日期				
顏色	EC-DG-D334232-ZD1(閃粉古銅)	批准	Daniel		圖號	W-MA01-709			

工程號	J-853	地盤	延坪道住宅
-----	-------	----	-------

序號	物料編號	L	數量	位置	分格尺寸	樓層	樓層數	每層數量	座數
1	W-MC01-708	2325	1	J853-SD-CW-4203右	2325	25/F	1	1	T7

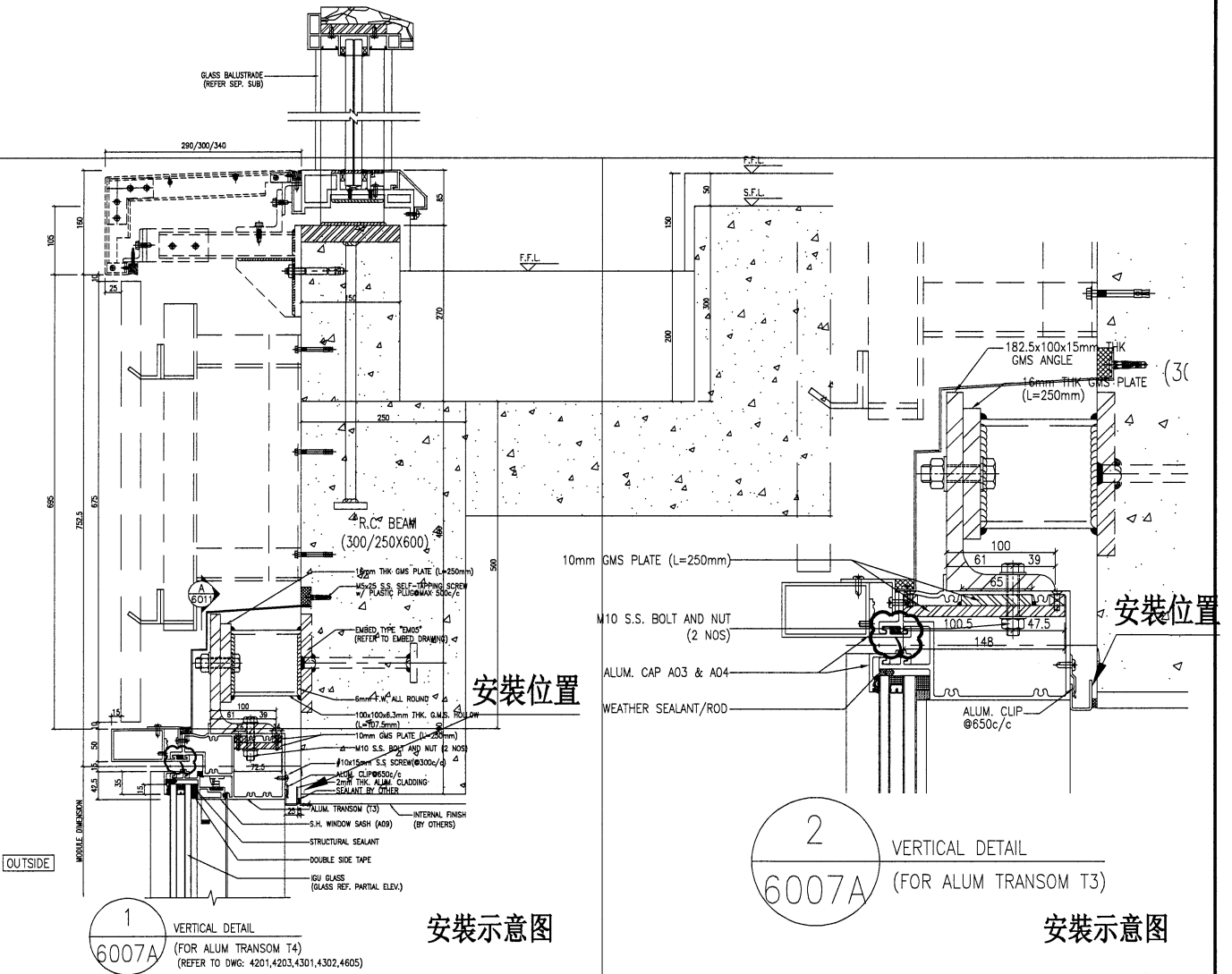
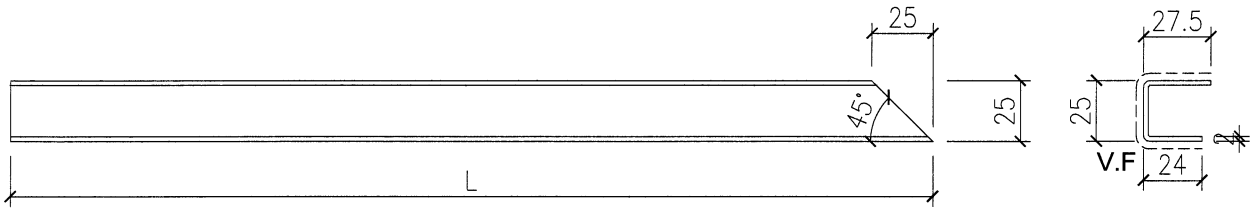

1  
6007A  
VERTICAL DETAIL  
(FOR ALUM TRANSOM T4)  
(REFER TO DWG: 4201,4203,4301,4302,4605)

安裝示意图

2  
6007A  
VERTICAL DETAIL  
(FOR ALUM TRANSOM T3)

安裝示意图

名稱	轉角橫向收口鋁板	制圖	方強	2023.05.08	修改			
材料	2mm鋁板	復核	謝永林	2023.05.20	日期			
顏色	EC-DG-D334232-ZD1(閃粉古銅)	批准	Daniel		圖號	W-MC01-708		

**美特鋁質有限公司**  
MIDI Aluminium Fabricator Ltd.

工程號 J-853 地盤 延坪道住宅

序號	物料編號	L	數量	位置	分格尺寸	樓層	樓層數	每層數量	座數
1	W-MC01-709	808	1	J853-SD-CW-4203右	1100	25/F	1	1	T7

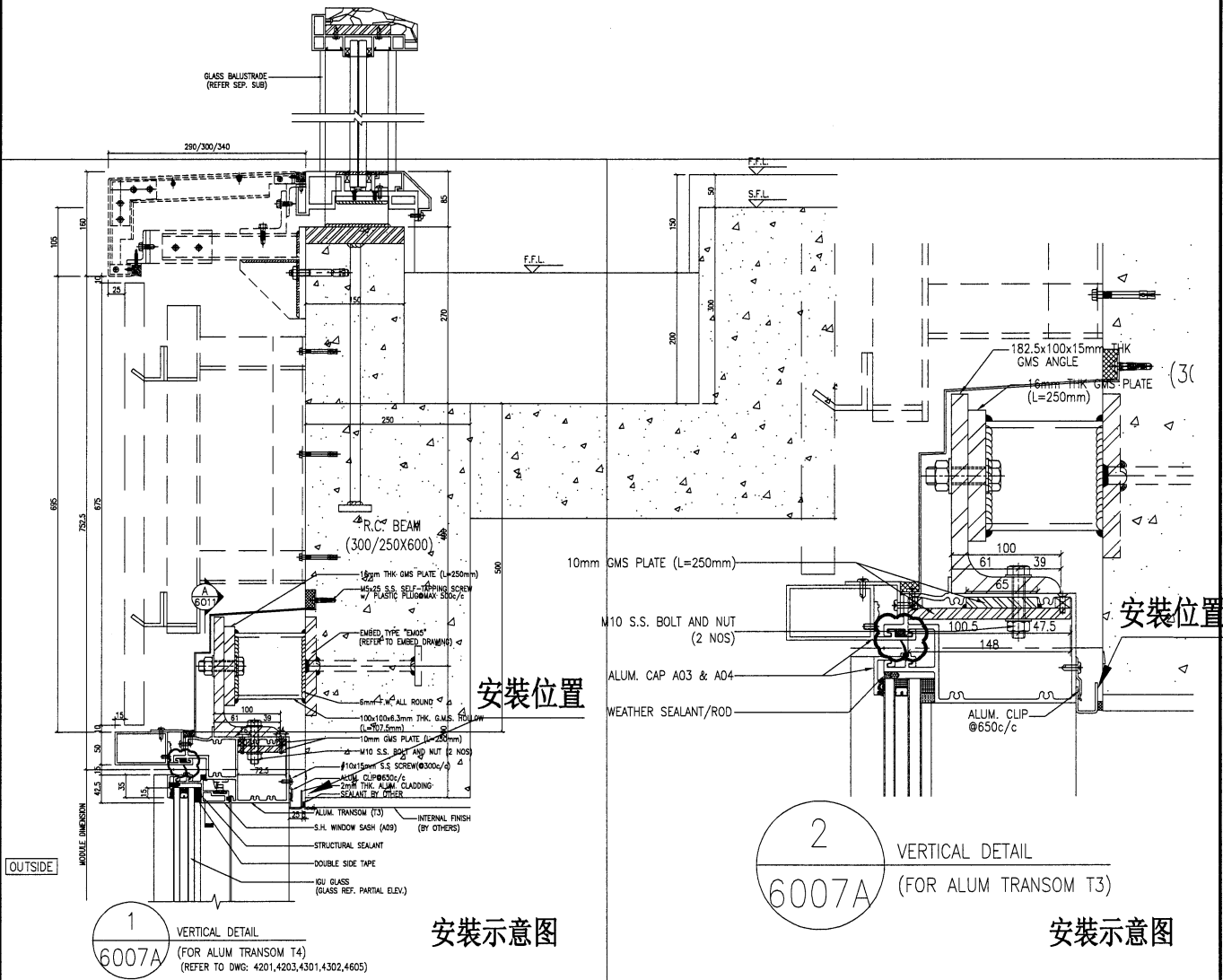
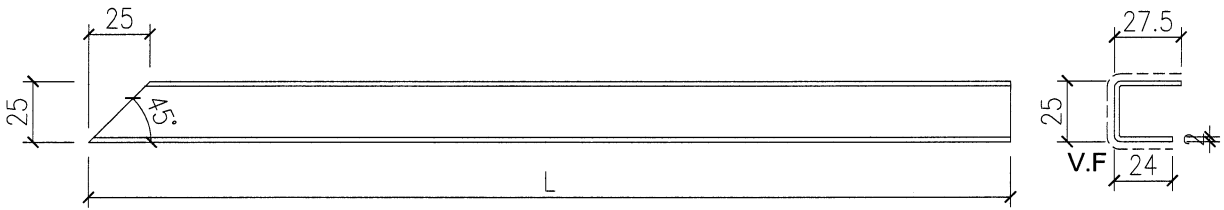

名稱	轉角橫向收口鋁板	制圖	方強	2023. 05. 08	修改			
材料	2mm鋁板	復核	謝永林	2023. 05. 20	日期			
顏色	EC-DG-D334232-ZD1 (閃粉古銅)	批准	Daniel		圖號	W-MC01-709		

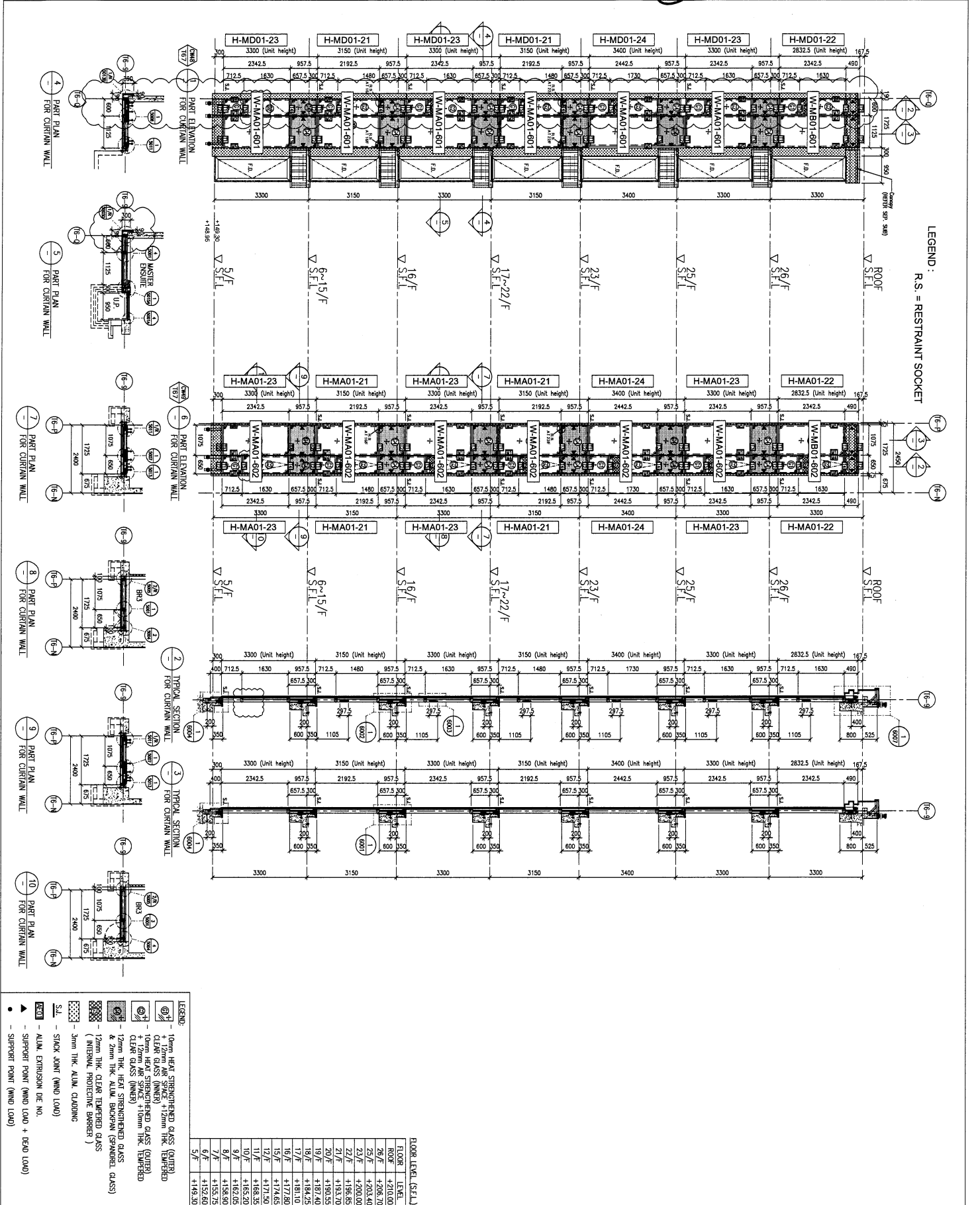

**B.D. REF:**

**CLIENT:**  
SHIMAO GROUP HOLDINGS LIMITED

**ARCHITECT:**  
WONG TUNG & PARTNERS LIMITED

**MAIN CONTRACTOR:**  
協興建築有限公司  
HIP HING CONSTRUCTION CO. LTD

**STRUCTURAL ENGINEER:**  
C M WONG & ASSOCIATES LTD  
葉志明建築工程師有限公司

**FAÇADE CONSULTANT:**  
MENHARDT

**NOTE:**  
1. ALL DIMENSIONS ARE IN mm.  
2. ALL ELEVATIONS ARE VIEWED FROM OUTSIDE.  
3. ALL DIMENSIONS TO BE VERIFIED ON SITE BEFORE FABRICATION.

**LEGEND:**  
 XI - DETAIL MARK NO.  
 (WIND) - FINISHED FLOOR LEVEL  
 2 S.F.L. - STRUCTURAL FLOOR LEVEL  
 3 (REV) - REVERSED DETAIL

**PROJECT:**  
PROPOSED RESIDENTIAL DEVELOPMENT AT N.K.L.L. 6542 YIN PING ROAD KOWLOON

**TITLE:**  
PART ELEVATION FOR CURTAIN WALL AT TOWER 6 & 7

**DATE:** 12-APR-21 **SCALE:** 1:60 (A1)

**DRAWN BY:** LHR **CHECKED BY:**

**UNIT:** J-853

**REVISION:**

**DATE:**

**DESIGNER:** 美特銘有限公司  
M.T.M. ENGINEERING & ARCHITECTURE LTD.  
Units E-8, Sunny Hill Industrial Building, 1/J  
610 Chee Kwee Ling Road, Kowloon  
Tel: 23248211-4 Fax: (852) 2727866  
DWG NO.: J853-SD-CW-4601

**REV:** B



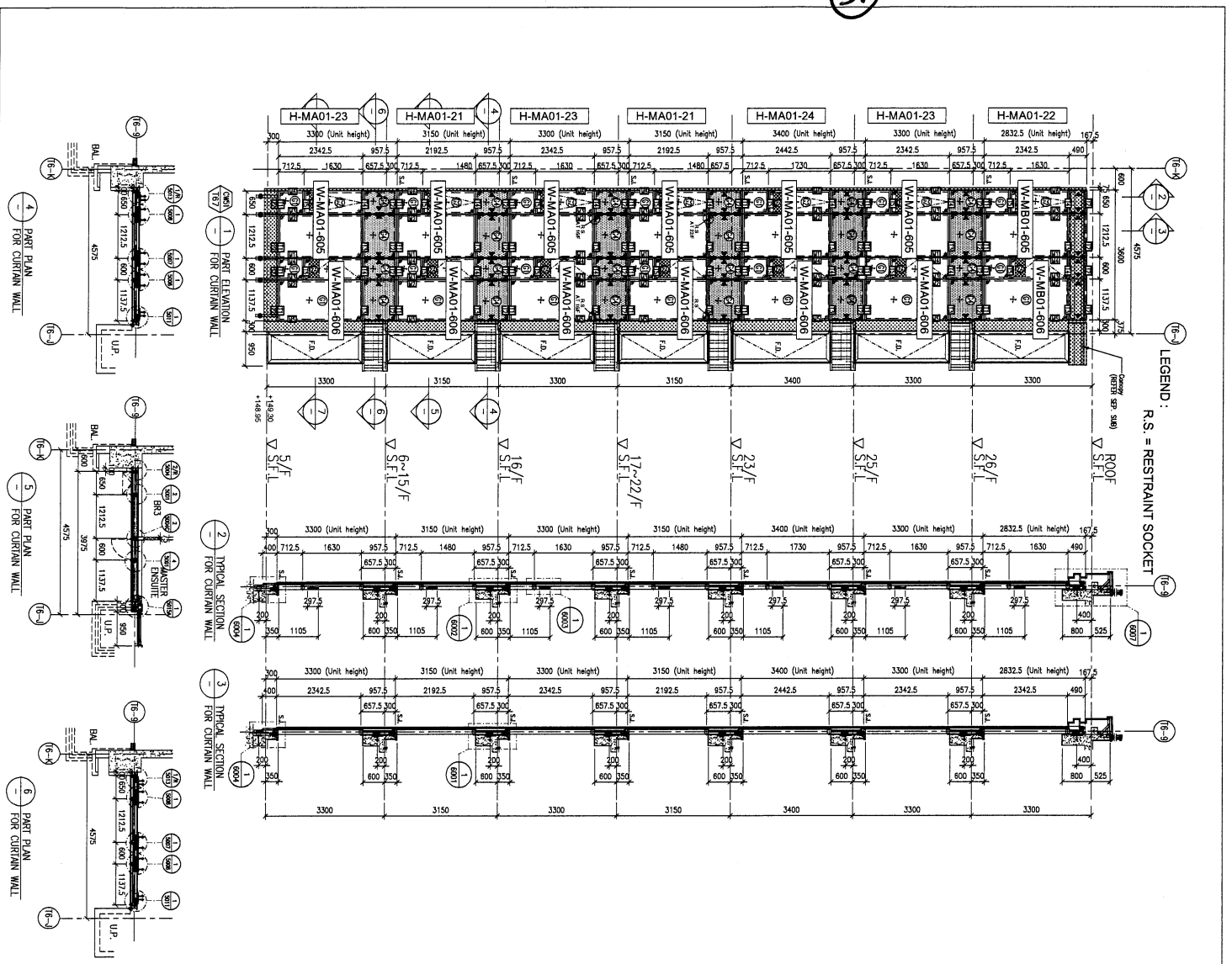

間牆位用鋁板: 2隻/層

H-MC01-21	(6-15/F, 17-22/F)
H-MC01-22	(26/F)
H-MC01-23	(5/F, 16/F, 25/F)
H-MC01-24	(23/F)

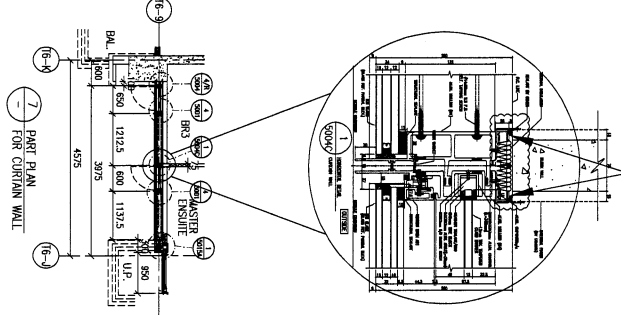

LEGEND:

- ① 10mm HEAT STRENGTHENED GLASS (OUTER CLEAR GLASS (INNER))
- ② 10mm HEAT STRENGTHENED GLASS (INNER CLEAR GLASS (INNER))
- ③ 12mm HEAT STRENGTHENED GLASS (OUTER CLEAR GLASS (INNER))
- ④ 12mm HEAT STRENGTHENED GLASS (INNER CLEAR GLASS (INNER))
- ⑤ 12mm HEAT STRENGTHENED GLASS (OUTER CLEAR GLASS (INNER))
- ⑥ 12mm HEAT STRENGTHENED GLASS (INNER CLEAR GLASS (INNER))
- ⑦ 12mm HEAT STRENGTHENED GLASS (OUTER CLEAR GLASS (INNER))
- ⑧ 12mm HEAT STRENGTHENED GLASS (INNER CLEAR GLASS (INNER))
- ⑨ 12mm HEAT STRENGTHENED GLASS (OUTER CLEAR GLASS (INNER))
- ⑩ 12mm HEAT STRENGTHENED GLASS (INNER CLEAR GLASS (INNER))
- ⑪ 12mm HEAT STRENGTHENED GLASS (OUTER CLEAR GLASS (INNER))
- ⑫ 12mm HEAT STRENGTHENED GLASS (INNER CLEAR GLASS (INNER))
- ⑬ 12mm HEAT STRENGTHENED GLASS (OUTER CLEAR GLASS (INNER))
- ⑭ 12mm HEAT STRENGTHENED GLASS (INNER CLEAR GLASS (INNER))
- ⑮ 12mm HEAT STRENGTHENED GLASS (OUTER CLEAR GLASS (INNER))
- ⑯ 12mm HEAT STRENGTHENED GLASS (INNER CLEAR GLASS (INNER))
- ⑰ 12mm HEAT STRENGTHENED GLASS (OUTER CLEAR GLASS (INNER))
- ⑱ 12mm HEAT STRENGTHENED GLASS (INNER CLEAR GLASS (INNER))
- ⑲ 12mm HEAT STRENGTHENED GLASS (OUTER CLEAR GLASS (INNER))
- ⑳ 12mm HEAT STRENGTHENED GLASS (INNER CLEAR GLASS (INNER))
- ㉑ 12mm HEAT STRENGTHENED GLASS (OUTER CLEAR GLASS (INNER))
- ㉒ 12mm HEAT STRENGTHENED GLASS (INNER CLEAR GLASS (INNER))
- ㉓ 12mm HEAT STRENGTHENED GLASS (OUTER CLEAR GLASS (INNER))
- ㉔ 12mm HEAT STRENGTHENED GLASS (INNER CLEAR GLASS (INNER))
- ㉕ 12mm HEAT STRENGTHENED GLASS (OUTER CLEAR GLASS (INNER))
- ㉖ 12mm HEAT STRENGTHENED GLASS (INNER CLEAR GLASS (INNER))
- ㉗ 12mm HEAT STRENGTHENED GLASS (OUTER CLEAR GLASS (INNER))
- ㉘ 12mm HEAT STRENGTHENED GLASS (INNER CLEAR GLASS (INNER))
- ㉙ 12mm HEAT STRENGTHENED GLASS (OUTER CLEAR GLASS (INNER))
- ㉚ 12mm HEAT STRENGTHENED GLASS (INNER CLEAR GLASS (INNER))
- ㉛ 12mm HEAT STRENGTHENED GLASS (OUTER CLEAR GLASS (INNER))
- ㉜ 12mm HEAT STRENGTHENED GLASS (INNER CLEAR GLASS (INNER))
- ㉝ 12mm HEAT STRENGTHENED GLASS (OUTER CLEAR GLASS (INNER))
- ㉞ 12mm HEAT STRENGTHENED GLASS (INNER CLEAR GLASS (INNER))
- ㉟ 12mm HEAT STRENGTHENED GLASS (OUTER CLEAR GLASS (INNER))
- ㊱ 12mm HEAT STRENGTHENED GLASS (INNER CLEAR GLASS (INNER))
- ㊲ 12mm HEAT STRENGTHENED GLASS (OUTER CLEAR GLASS (INNER))
- ㊳ 12mm HEAT STRENGTHENED GLASS (INNER CLEAR GLASS (INNER))
- ㊴ 12mm HEAT STRENGTHENED GLASS (OUTER CLEAR GLASS (INNER))
- ㊵ 12mm HEAT STRENGTHENED GLASS (INNER CLEAR GLASS (INNER))
- ㊶ 12mm HEAT STRENGTHENED GLASS (OUTER CLEAR GLASS (INNER))
- ㊷ 12mm HEAT STRENGTHENED GLASS (INNER CLEAR GLASS (INNER))
- ㊸ 12mm HEAT STRENGTHENED GLASS (OUTER CLEAR GLASS (INNER))
- ㊹ 12mm HEAT STRENGTHENED GLASS (INNER CLEAR GLASS (INNER))
- ㊺ 12mm HEAT STRENGTHENED GLASS (OUTER CLEAR GLASS (INNER))
- ㊻ 12mm HEAT STRENGTHENED GLASS (INNER CLEAR GLASS (INNER))
- ㊼ 12mm HEAT STRENGTHENED GLASS (OUTER CLEAR GLASS (INNER))
- ㊽ 12mm HEAT STRENGTHENED GLASS (INNER CLEAR GLASS (INNER))
- ㊾ 12mm HEAT STRENGTHENED GLASS (OUTER CLEAR GLASS (INNER))
- ㊿ 12mm HEAT STRENGTHENED GLASS (INNER CLEAR GLASS (INNER))

FLOOR LEVEL (S.F.L.)

FLOOR	LEVEL
ROOF	+210.00
26/F	+206.70
25/F	+203.40
23/F	+200.00
22/F	+196.85
21/F	+193.70
20/F	+190.55
19/F	+187.40
18/F	+184.25
17/F	+181.10
16/F	+177.80
15/F	+174.65
12/F	+171.50
11/F	+168.35
10/F	+165.20
9/F	+162.05
8/F	+158.90
7/F	+155.75
6/F	+152.60
5/F	+149.45

CLIENT: SHIMAO GROUP HOLDINGS LIMITED

ARCHITECT: WONG TUNG & PARTNERS LIMITED

MAIN CONTRACTOR: 協興建築有限公司 HHP HING CONSTRUCTION CO LTD

STRUCTURAL ENGINEER: C M WONG & ASSOCIATES LTD 黃志明建築工程師有限公司

FAÇADE CONSULTANT: MENHARDT

PROJECT: PROPOSED RESIDENTIAL DEVELOPMENT AT N.K.L.L. 6542 YIN HING ROAD KOWLOON

DATE: 24-OCT-21 SCALE: 1:60 (A-1)

DRAWN BY: LHR CHECKED BY:

UNIT: 6-8, Sunny Industrial Centre, 1/F, 610 Cha Kwo Ling Road, Kowloon Tel: 23982111-4 Fax: (852) 27277656 DMC NO.: 1853-SI-CW-46024 REV.: B

NOTE: 1. ALL DIMENSIONS ARE IN mm. 2. ALL DIMENSIONS ARE VERIFIED FROM OUTSIDE BEFORE FABRICATION. 3. ALL DIMENSIONS TO BE VERIFIED ON SITE BEFORE FABRICATION.

LEGEND: ① DETAIL MARK NO. ② REFER SHEET NO. ③ F.F.L. - FINISHED FLOOR LEVEL. ④ S.F.L. - STRUCTURAL FLOOR LEVEL. ⑤ INVERTED DETAIL.



LEGEND :  
R.S. = RESTRAINT SOCKET

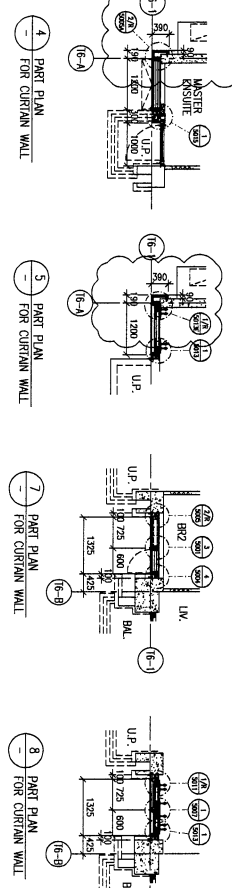
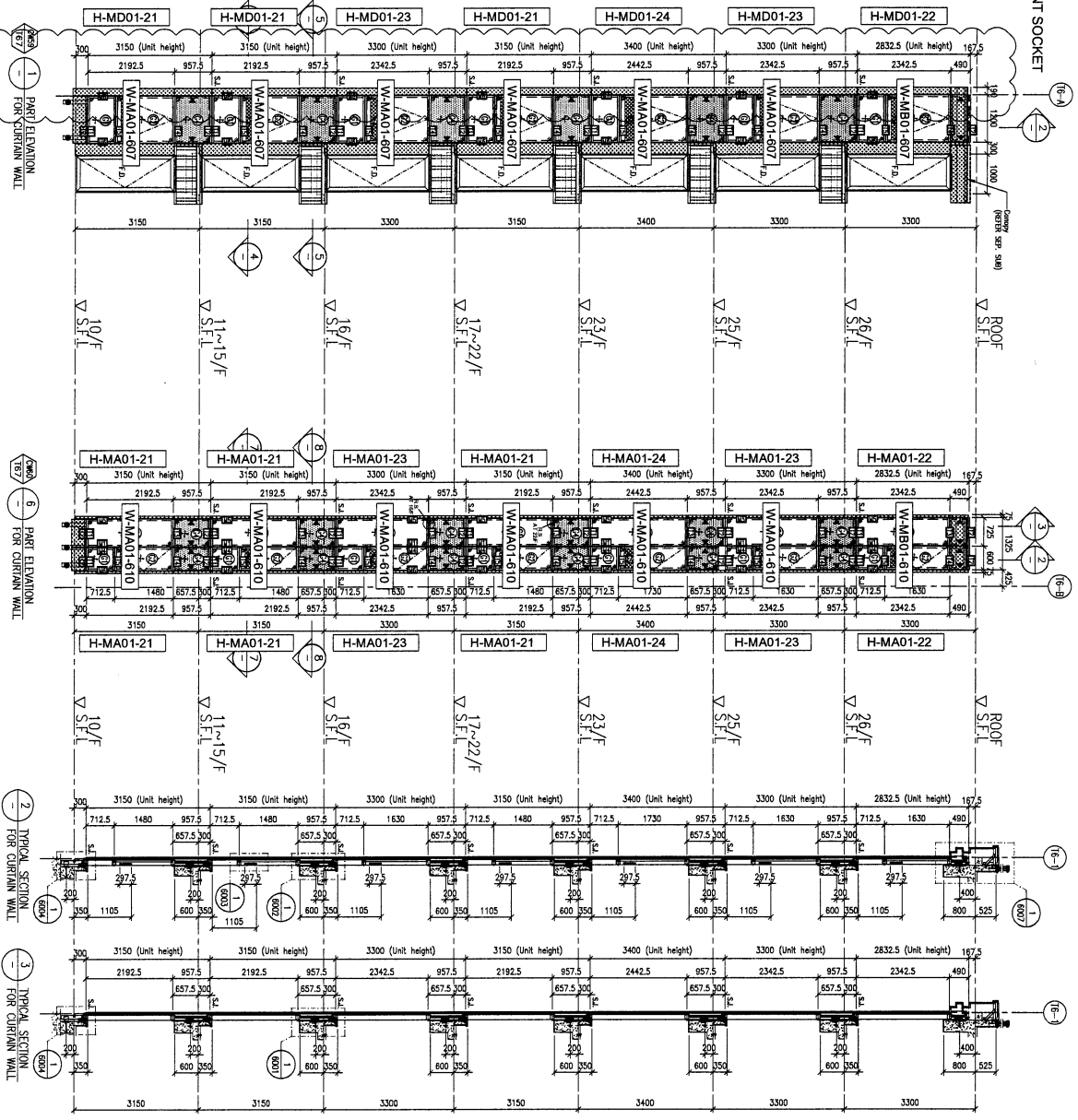

- LEGEND:**
- ① 10mm HEAT STRENGTHENED GLASS (QUER)
  - ② 10mm CLEAR GLASS (INNER)
  - ③ 10mm HEAT STRENGTHENED GLASS (QUER) + 12mm AIR SPACE + 10mm THK. TEMPERED CLEAR GLASS (INNER)
  - ④ 12mm THK. HEAT STRENGTHENED GLASS
  - ⑤ 12mm THK. ALUM. BACKPAN (SPRINKLER GLASS)
  - ⑥ 3mm THK. ALUM. CLADDING
  - ⑦ STICK JOINT (WIND LOAD)
  - ⑧ ALUM. EXTRUSION (WIND LOAD)
  - ⑨ SUPPORT POINT (WIND LOAD + DEAD LOAD)
  - ⑩ SUPPORT POINT (WIND LOAD)

FLOOR LEVEL (S.F.L.)	FLOOR LEVEL
ROOF	+210.00
26/F	+206.70
25/F	+203.40
23/F	+200.00
22/F	+196.85
21/F	+193.70
20/F	+190.55
19/F	+187.40
17/F	+184.25
16/F	+181.10
15/F	+177.80
12/F	+174.65
11/F	+171.50
10/F	+168.35
	+165.20

**CLIENT:**  
SHIMAO GROUP HOLDINGS LIMITED

**ARCHITECT:**  
WONG TUNG & PARTNERS LIMITED

**MAIN CONTRACTOR:**  
WTF

**STRUCTURAL ENGINEER:**  
C M WONG & ASSOCIATES LTD  
黃志剛建築工程師有限公司

**FAÇADE CONSULTANT:**  
MENHARDT

**DATE:** 13-APR-21  
**SCALE:** 1:60 (A1)

**TITLE:**  
PART ELEVATION FOR CURTAIN WALL AT TOWER 6 & 7  
KOWLOON

**PROJECT:**  
PROPOSED RESIDENTIAL DEVELOPMENT AT N.K.I.L. 6542 YIN PING ROAD KOWLOON

**DRAWN BY:** LHR  
**CHECKED BY:**

**DESIGNER:** 黃志剛建築工程師有限公司  
Units E-8, Sunny Industrial Estate, 1/F  
610 Chee Koo Ling Road, Kowloon  
Tel: 23489211-4 Fax: (852) 27277865  
DWG NO.: 1853-SO-CW-4607

**REV.:** C

NO.	DATE	REVISION	BY
1	08-15-2021	REVISION SUBJECT TO ARCH. COMMENT	BY

**JOB NO.:** J-853

**NOTE:**

1. DIMENSIONS ARE IN mm.
2. ALL DIMENSIONS ARE MARKED FROM OUTSIDE.
3. ALL DIMENSIONS TO BE VERIFIED ON SITE BEFORE FABRICATION.

**LEGEND:**

- ① DETAIL MARK NO.
- ② REFER SHEET NO.
- 1. F.F.L. — FINISHED FLOOR LEVEL.
- 2. S.F.L. — STRUCTURAL FLOOR LEVEL.
- 3. (R) — REVERSED DETAIL.

**CLIENT:** SHIMAO GROUP HOLDINGS LIMITED

**ARCHITECT:** WONG TUNG & PARTNERS LIMITED

**MAIN CONTRACTOR:** WTF

**STRUCTURAL ENGINEER:** C M WONG & ASSOCIATES LTD  
黃志剛建築工程師有限公司

**FAÇADE CONSULTANT:** MENHARDT

**DATE:** 13-APR-21  
**SCALE:** 1:60 (A1)

**TITLE:** PART ELEVATION FOR CURTAIN WALL AT TOWER 6 & 7  
KOWLOON

**PROJECT:** PROPOSED RESIDENTIAL DEVELOPMENT AT N.K.I.L. 6542 YIN PING ROAD KOWLOON

**DRAWN BY:** LHR  
**CHECKED BY:**

**DESIGNER:** 黃志剛建築工程師有限公司  
Units E-8, Sunny Industrial Estate, 1/F  
610 Chee Koo Ling Road, Kowloon  
Tel: 23489211-4 Fax: (852) 27277865  
DWG NO.: 1853-SO-CW-4607

**REV.:** C

LEGEND :  
R.S. = RESTRAINT SOCKET

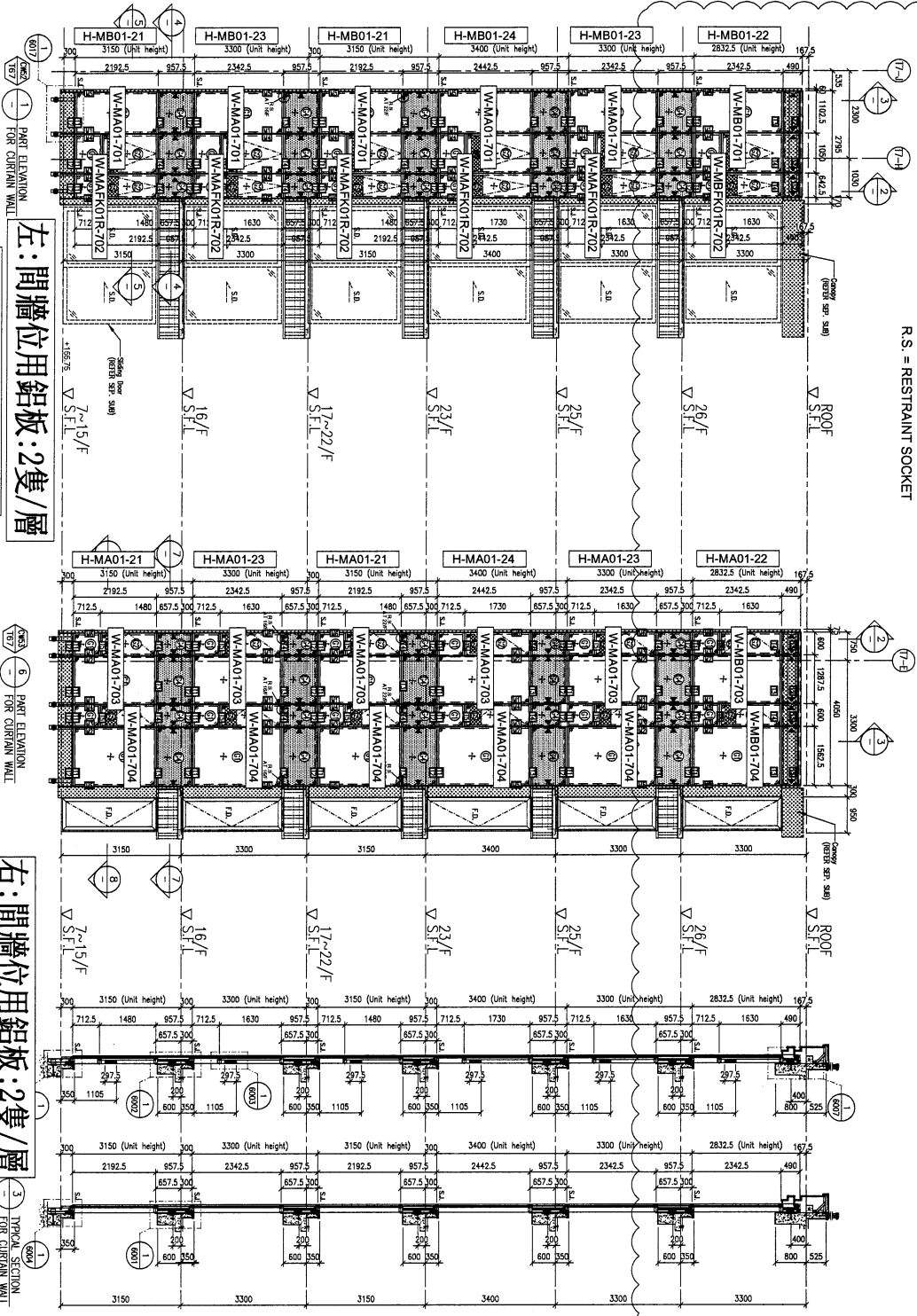

左: 間牆位用鋁板: 2隻/層

右: 間牆位用鋁板: 2隻/層

- H-MC01-21 (7-15/F, 17-22/F)
- H-MC01-22 (26/F)
- H-MC01-23 (16/F, 25/F)
- H-MC01-24 (23/F)

- H-MC01-21 (7-15/F, 17-22/F)
- H-MC01-22 (26/F)
- H-MC01-23 (16/F, 25/F)
- H-MC01-24 (23/F)

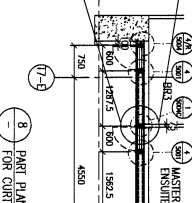
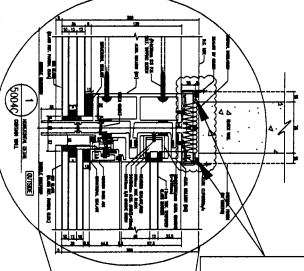
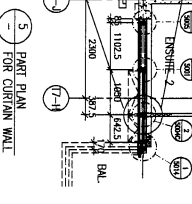
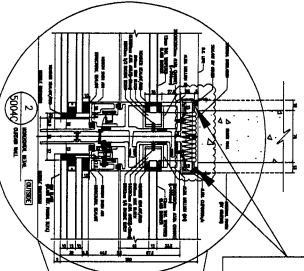

- LEGEND:
- 10mm HEAT STRENGTHENED GLASS (QUERED)
  - 12mm HEAT STRENGTHENED GLASS (QUERED)
  - 12mm HEAT STRENGTHENED GLASS (QUERED) + 12mm AIR SPACE + 10mm THK. TEMPERED CLEAR GLASS (INNER)
  - 12mm THK. HEAT STRENGTHENED GLASS (QUERED) + 20mm THK. ALUM. BACKPAK (CHAMFERED GLASS)
  - 12mm THK. CLEAR TEMPERED GLASS (INTERNAL PROTECTIVE BARRIER)
  - 3mm THK. ALUM. CLADDING
  - 10mm HEAT STRENGTHENED GLASS (QUERED)
  - 12mm HEAT STRENGTHENED GLASS (QUERED)
  - 12mm HEAT STRENGTHENED GLASS (QUERED) + 12mm AIR SPACE + 10mm THK. TEMPERED CLEAR GLASS (INNER)
  - 12mm THK. HEAT STRENGTHENED GLASS (QUERED) + 20mm THK. ALUM. BACKPAK (CHAMFERED GLASS)
  - 12mm THK. CLEAR TEMPERED GLASS (INTERNAL PROTECTIVE BARRIER)
  - 3mm THK. ALUM. CLADDING

FLOOR LEVEL (S.F.L.)	FLOOR LEVEL
ROOF	+210.00
26/F	+206.70
25/F	+203.40
23/F	+200.00
22/F	+198.85
21/F	+193.70
20/F	+190.55
19/F	+187.40
18/F	+184.25
17/F	+181.10
16/F	+177.95
15/F	+174.80
12/F	+171.50
11/F	+168.35
10/F	+165.20
9/F	+162.05
7/F	+158.90
7/F	+155.75

NOTE:  
1. ALL DIMENSIONS ARE IN mm.  
2. ALL ELEVATIONS ARE VERIFIED FROM OUTSIDE.  
3. ALL DIMENSIONS TO BE VERIFIED ON SITE BEFORE FABRICATION.

LEGEND:  
X1 - DETAIL MARK NO.  
WIND - WIND SHEET NO.  
1. F.F.L. - FINISHED FLOOR LEVEL  
2. S.F.L. - STRUCTURAL FLOOR LEVEL  
3. R.S. - REVERSED DETAIL

CLIENT:  
**SHIMAO GROUP HOLDINGS LIMITED**

ARCHITECT:  
**WONG TUNG & PARTNERS LIMITED**

MAIN CONTRACTOR:  
**協興建築有限公司 HYP HING CONSTRUCTION CO. LTD**

STRUCTURAL ENGINEER:  
**C M WONG & ASSOCIATES LTD 葉志明建築工程師有限公司**

FAÇADE CONSULTANT:  
**MENHARDT**

PROJECT:  
PROPOSED RESIDENTIAL DEVELOPMENT AT N.K.L.L. 6542 KOWLOON

TITLE:  
PART ELEVATION FOR CURTAIN WALL AT TOWER 6 & 7

DATE: 12-APR-21 SCALE: 1:60 (A1)

DRAWN BY: LHR CHECKED BY: [Signature]

UNIT: 8-8, Sunny Industrial Centre, 1/F, 610 Chee Kwo Ling Road, Kowloon, Tel: 24248211-4 Fax: (852) 27272666 DWG NO.: 1853-SD-CW-4603 REV.: C

LEGEND :  
R.S. = RESTRAINT SOCKET

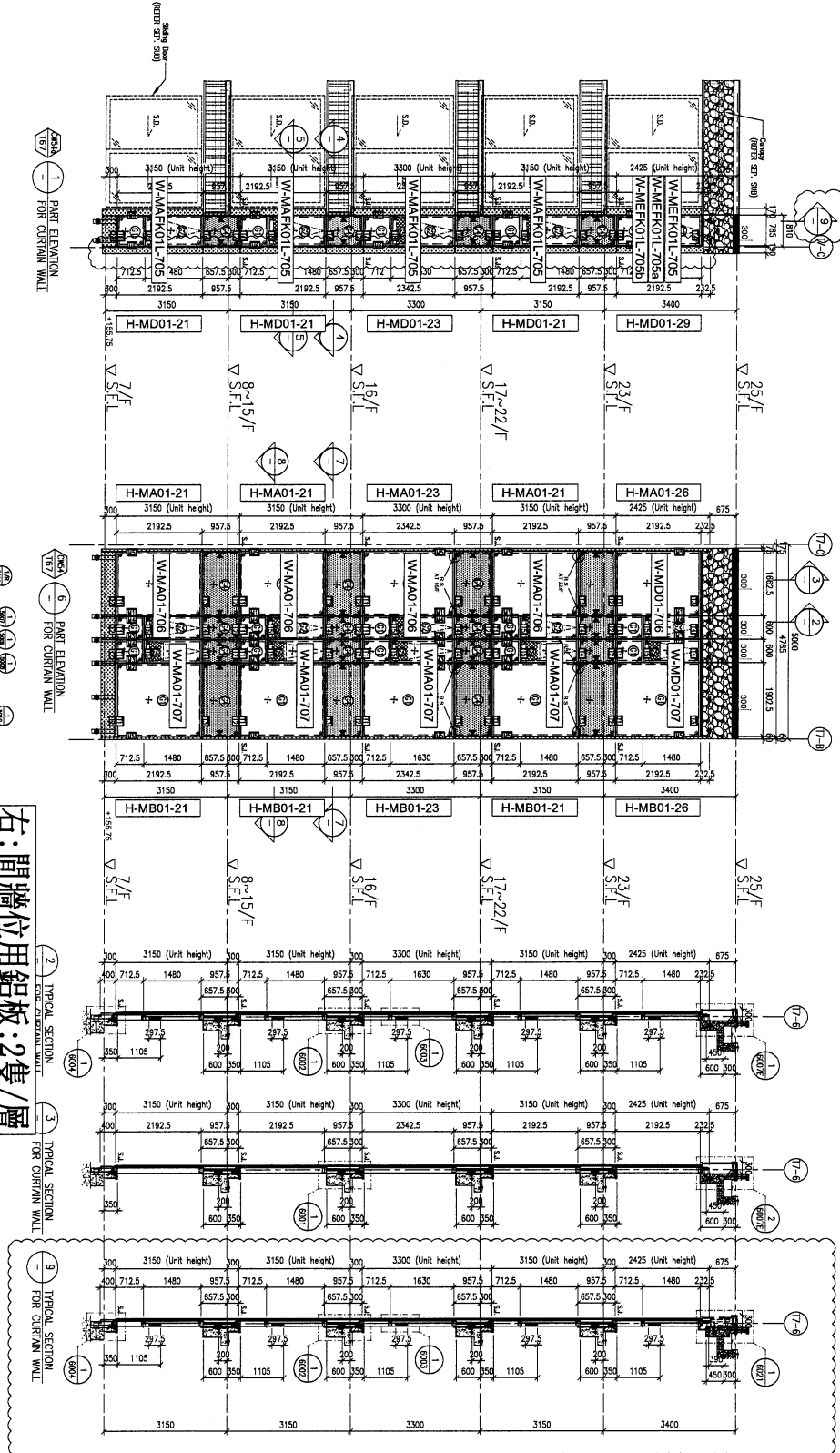

右:間牆位用鋁板:2隻/層

H-MC01-21	(7.15/F, 17.22/F)
H-MC01-23	(16/F)
H-MC01-26	(23/F)

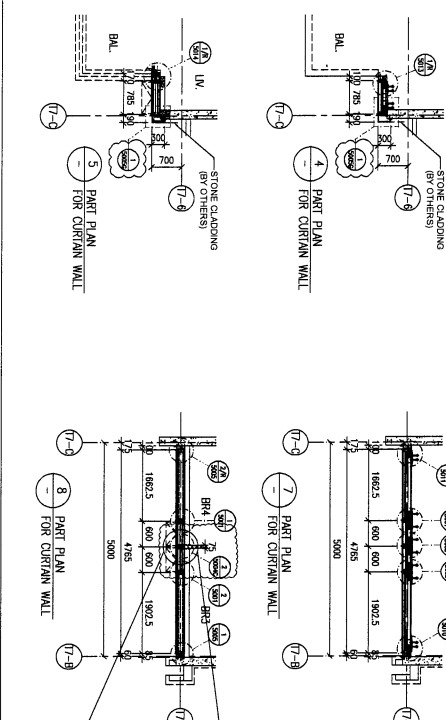

**LEGEND:**

- 10mm HEAT STRENGTHENED GLASS (OUTER)
- 10mm HEAT STRENGTHENED GLASS (INNER)
- 10mm HEAT STRENGTHENED GLASS (INNER) + 12mm AIR SPACE + 10mm HEAT STRENGTHENED CLEAR GLASS (INNER)
- 12mm THK. HEAT STRENGTHENED GLASS & 2mm THK. ALUM. BACKPAN (SPANDREL GLASS) (INTERNAL PROTECTIVE BARRIER)
- 12mm THK. CLEAR TEMPERED GLASS
- 10mm HEAT STRENGTHENED GLASS (OUTER)
- 10mm HEAT STRENGTHENED GLASS (INNER)
- 10mm HEAT STRENGTHENED GLASS (INNER) + 12mm AIR SPACE + 10mm HEAT STRENGTHENED CLEAR GLASS (INNER)
- 12mm THK. HEAT STRENGTHENED GLASS & 2mm THK. ALUM. BACKPAN (SPANDREL GLASS) (INTERNAL PROTECTIVE BARRIER)
- 12mm THK. CLEAR TEMPERED GLASS

**SCALE:** 1:50

**DATE:** 12-APR-21

**SCALE:** 1:50 (A1)

**FLOOR LEVEL (S.F.L.)**

FLOOR	LEVEL
25/F	+203.40
23/F	+200.00
22/F	+196.85
21/F	+193.70
20/F	+190.55
19/F	+187.40
18/F	+184.25
17/F	+181.10
16/F	+177.95
15/F	+174.80
12/F	+171.50
11/F	+168.35
10/F	+165.20
9/F	+162.05
8/F	+158.90
7/F	+155.75

**PROJECT:** PROPOSED RESIDENTIAL DEVELOPMENT AT N.K.I.L.L. 6542 YIN PING ROAD KOWLOON

**TITLE:** PART ELEVATION FOR CURTAIN WALL AT TOWER 6 & 7

**DRAWN BY:** LHR

**CHECKED BY:**

**DATE:** 12-APR-21

**SCALE:** 1:50 (A1)

**CLIENT:** SHIMAO GROUP HOLDINGS LIMITED

**ARCHITECT:** WONG TUNG & PARTNERS LIMITED

**MAIN CONTRACTOR:** 協興建築有限公司 AP HING CONSTRUCTION CO LTD

**STRUCTURAL ENGINEER:** C W WONG & ASSOCIATES LTD 黃志明建築工程師有限公司

**FAÇADE CONSULTANT:** MENHARDT

**NOTE:**

- ALL DIMENSIONS ARE IN mm.
- ALL DIMENSIONS ARE MARKED FROM OUTSIDE.
- ALL DIMENSIONS TO BE VERIFIED ON SITE BEFORE FABRICATION.

**LEGEND:**

- 1. F.F.L. --- FINISHED FLOOR LEVEL
- 2. S.F.L. --- STRUCTURAL FLOOR LEVEL
- 3. (R) --- REVERSED DETAIL

**DETAIL MARK NO.:** (W) --- REFER SHEET NO.

**DATE:** 12-APR-21

**REVISION:**

NO.	DATE	REVISION	BY
1	12-APR-21	ISSUED SUBJECT TO ARCH. COMMENT	LHR

**SHIMAO GROUP HOLDINGS LIMITED**

**WONG TUNG & PARTNERS LIMITED**

**協興建築有限公司 AP HING CONSTRUCTION CO LTD**

**C W WONG & ASSOCIATES LTD 黃志明建築工程師有限公司**

**MENHARDT**

**SHIMAO GROUP HOLDINGS LIMITED**

**WONG TUNG & PARTNERS LIMITED**

**協興建築有限公司 AP HING CONSTRUCTION CO LTD**

**C W WONG & ASSOCIATES LTD 黃志明建築工程師有限公司**

**MENHARDT**

**SHIMAO GROUP HOLDINGS LIMITED**

**WONG TUNG & PARTNERS LIMITED**

**協興建築有限公司 AP HING CONSTRUCTION CO LTD**

**C W WONG & ASSOCIATES LTD 黃志明建築工程師有限公司**

**MENHARDT**

**SHIMAO GROUP HOLDINGS LIMITED**

**WONG TUNG & PARTNERS LIMITED**

**協興建築有限公司 AP HING CONSTRUCTION CO LTD**

**C W WONG & ASSOCIATES LTD 黃志明建築工程師有限公司**

**MENHARDT**

**SHIMAO GROUP HOLDINGS LIMITED**

**WONG TUNG & PARTNERS LIMITED**

**協興建築有限公司 AP HING CONSTRUCTION CO LTD**

**C W WONG & ASSOCIATES LTD 黃志明建築工程師有限公司**

**MENHARDT**

**SHIMAO GROUP HOLDINGS LIMITED**

**WONG TUNG & PARTNERS LIMITED**

**協興建築有限公司 AP HING CONSTRUCTION CO LTD**

**C W WONG & ASSOCIATES LTD 黃志明建築工程師有限公司**

**MENHARDT**

**SHIMAO GROUP HOLDINGS LIMITED**

**WONG TUNG & PARTNERS LIMITED**

**協興建築有限公司 AP HING CONSTRUCTION CO LTD**

**C W WONG & ASSOCIATES LTD 黃志明建築工程師有限公司**

**MENHARDT**



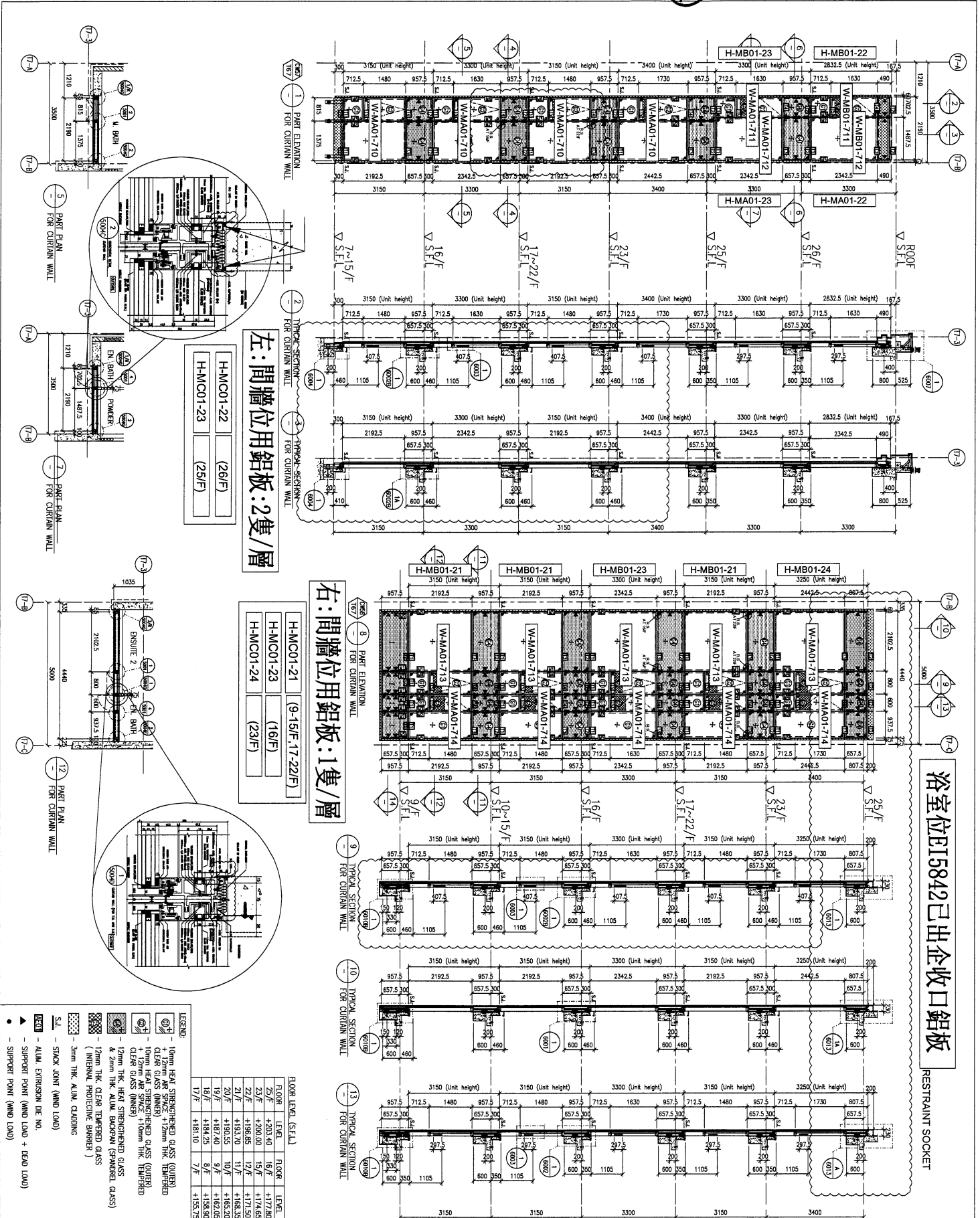

浴室位E15842已出企收口鋁板

RESTRAINT SOCKET

左: 間牆位用鋁板: 2隻/層

H-MC01-22	(26/F)
H-MC01-23	(25/F)

右: 間牆位用鋁板: 1隻/層

H-MC01-21	(9-15/F, 17-22/F)
H-MC01-23	(16/F)
H-MC01-24	(23/F)

FLOOR LEVEL (S.F.L.)

FLOOR	LEVEL	FLOOR	LEVEL
25/F	+293.40	16/F	+177.80
23/F	+290.00	15/F	+174.65
22/F	+196.85	12/F	+171.50
21/F	+193.70	11/F	+168.35
20/F	+190.55	10/F	+165.20
19/F	+187.40	9/F	+162.05
18/F	+184.25	8/F	+158.90
17/F	+181.10	7/F	+155.75

- LEGEND:
- ① 10mm HEAT STRENGTHENED GLASS (QUER)
  - ② 10mm CLEAR GLASS (INNER)
  - ③ 10mm HEAT STRENGTHENED GLASS (QUER) + 12mm HEAT STRENGTHENED GLASS (QUER) + 12mm CLEAR GLASS (INNER)
  - ④ 12mm HEAT STRENGTHENED GLASS (QUER) + 12mm CLEAR GLASS (INNER)
  - ⑤ 12mm THK. ALUM. BACKPAN (SPANDREL GLASS)
  - ⑥ 12mm THK. CLEAR TEMPERED GLASS (INTERNAL PROTECTIVE BARRIER)
  - ⑦ 3mm THK. ALUM. CLADDING
  - ⑧ STICK JOINT (WIND LOAD)
  - ⑨ STICK JOINT (WIND LOAD) + BEAD (LOAD)
  - ⑩ ALUM. EXTRUSION (IE NO.)
  - ⑪ SUPPORT POINT (WIND LOAD) + BEAD (LOAD)
  - ⑫ SUPPORT POINT (WIND LOAD)

CLIENT: SHIMAO GROUP HOLDINGS LIMITED

ARCHITECT: WONG TUNG & PARTNERS LIMITED

STRUCTURAL ENGINEER: C M WONG & ASSOCIATES LTD

MAIN CONTRACTOR: HHP HING CONSTRUCTION CO LTD

FAÇADE CONSULTANT: MENYARDT

PROJECT: PROPOSED RESIDENTIAL DEVELOPMENT AT NIKILL 6542 YIN PING ROAD KOWLOON

DATE: 13-APR-21

SCALE: 1:60 (A1)

JOB NO.: J-853

DATE: 08-10-2021

REVISION SUBJECT TO ARCH. COMMENT

DATE: 08-10-2021

BY: [Signature]

CHK: [Signature]

APP: [Signature]

REV: B

UNIT: 5-18, 5-19, 5-20, 5-21, 5-22, 5-23, 5-24, 5-25, 5-26, 5-27, 5-28, 5-29, 5-30, 5-31, 5-32, 5-33, 5-34, 5-35, 5-36, 5-37, 5-38, 5-39, 5-40, 5-41, 5-42, 5-43, 5-44, 5-45, 5-46, 5-47, 5-48, 5-49, 5-50, 5-51, 5-52, 5-53, 5-54, 5-55, 5-56, 5-57, 5-58, 5-59, 5-60, 5-61, 5-62, 5-63, 5-64, 5-65, 5-66, 5-67, 5-68, 5-69, 5-70, 5-71, 5-72, 5-73, 5-74, 5-75, 5-76, 5-77, 5-78, 5-79, 5-80, 5-81, 5-82, 5-83, 5-84, 5-85, 5-86, 5-87, 5-88, 5-89, 5-90, 5-91, 5-92, 5-93, 5-94, 5-95, 5-96, 5-97, 5-98, 5-99, 5-100, 5-101, 5-102, 5-103, 5-104, 5-105, 5-106, 5-107, 5-108, 5-109, 5-110, 5-111, 5-112, 5-113, 5-114, 5-115, 5-116, 5-117, 5-118, 5-119, 5-120, 5-121, 5-122, 5-123, 5-124, 5-125, 5-126, 5-127, 5-128, 5-129, 5-130, 5-131, 5-132, 5-133, 5-134, 5-135, 5-136, 5-137, 5-138, 5-139, 5-140, 5-141, 5-142, 5-143, 5-144, 5-145, 5-146, 5-147, 5-148, 5-149, 5-150, 5-151, 5-152, 5-153, 5-154, 5-155, 5-156, 5-157, 5-158, 5-159, 5-160, 5-161, 5-162, 5-163, 5-164, 5-165, 5-166, 5-167, 5-168, 5-169, 5-170, 5-171, 5-172, 5-173, 5-174, 5-175, 5-176, 5-177, 5-178, 5-179, 5-180, 5-181, 5-182, 5-183, 5-184, 5-185, 5-186, 5-187, 5-188, 5-189, 5-190, 5-191, 5-192, 5-193, 5-194, 5-195, 5-196, 5-197, 5-198, 5-199, 5-200, 5-201, 5-202, 5-203, 5-204, 5-205, 5-206, 5-207, 5-208, 5-209, 5-210, 5-211, 5-212, 5-213, 5-214, 5-215, 5-216, 5-217, 5-218, 5-219, 5-220, 5-221, 5-222, 5-223, 5-224, 5-225, 5-226, 5-227, 5-228, 5-229, 5-230, 5-231, 5-232, 5-233, 5-234, 5-235, 5-236, 5-237, 5-238, 5-239, 5-240, 5-241, 5-242, 5-243, 5-244, 5-245, 5-246, 5-247, 5-248, 5-249, 5-250, 5-251, 5-252, 5-253, 5-254, 5-255, 5-256, 5-257, 5-258, 5-259, 5-260, 5-261, 5-262, 5-263, 5-264, 5-265, 5-266, 5-267, 5-268, 5-269, 5-270, 5-271, 5-272, 5-273, 5-274, 5-275, 5-276, 5-277, 5-278, 5-279, 5-280, 5-281, 5-282, 5-283, 5-284, 5-285, 5-286, 5-287, 5-288, 5-289, 5-290, 5-291, 5-292, 5-293, 5-294, 5-295, 5-296, 5-297, 5-298, 5-299, 5-300, 5-301, 5-302, 5-303, 5-304, 5-305, 5-306, 5-307, 5-308, 5-309, 5-310, 5-311, 5-312, 5-313, 5-314, 5-315, 5-316, 5-317, 5-318, 5-319, 5-320, 5-321, 5-322, 5-323, 5-324, 5-325, 5-326, 5-327, 5-328, 5-329, 5-330, 5-331, 5-332, 5-333, 5-334, 5-335, 5-336, 5-337, 5-338, 5-339, 5-340, 5-341, 5-342, 5-343, 5-344, 5-345, 5-346, 5-347, 5-348, 5-349, 5-350, 5-351, 5-352, 5-353, 5-354, 5-355, 5-356, 5-357, 5-358, 5-359, 5-360, 5-361, 5-362, 5-363, 5-364, 5-365, 5-366, 5-367, 5-368, 5-369, 5-370, 5-371, 5-372, 5-373, 5-374, 5-375, 5-376, 5-377, 5-378, 5-379, 5-380, 5-381, 5-382, 5-383, 5-384, 5-385, 5-386, 5-387, 5-388, 5-389, 5-390, 5-391, 5-392, 5-393, 5-394, 5-395, 5-396, 5-397, 5-398, 5-399, 5-400, 5-401, 5-402, 5-403, 5-404, 5-405, 5-406, 5-407, 5-408, 5-409, 5-410, 5-411, 5-412, 5-413, 5-414, 5-415, 5-416, 5-417, 5-418, 5-419, 5-420, 5-421, 5-422, 5-423, 5-424, 5-425, 5-426, 5-427, 5-428, 5-429, 5-430, 5-431, 5-432, 5-433, 5-434, 5-435, 5-436, 5-437, 5-438, 5-439, 5-440, 5-441, 5-442, 5-443, 5-444, 5-445, 5-446, 5-447, 5-448, 5-449, 5-450, 5-451, 5-452, 5-453, 5-454, 5-455, 5-456, 5-457, 5-458, 5-459, 5-460, 5-461, 5-462, 5-463, 5-464, 5-465, 5-466, 5-467, 5-468, 5-469, 5-470, 5-471, 5-472, 5-473, 5-474, 5-475, 5-476, 5-477, 5-478, 5-479, 5-480, 5-481, 5-482, 5-483, 5-484, 5-485, 5-486, 5-487, 5-488, 5-489, 5-490, 5-491, 5-492, 5-493, 5-494, 5-495, 5-496, 5-497, 5-498, 5-499, 5-500, 5-501, 5-502, 5-503, 5-504, 5-505, 5-506, 5-507, 5-508, 5-509, 5-510, 5-511, 5-512, 5-513, 5-514, 5-515, 5-516, 5-517, 5-518, 5-519, 5-520, 5-521, 5-522, 5-523, 5-524, 5-525, 5-526, 5-527, 5-528, 5-529, 5-530, 5-531, 5-532, 5-533, 5-534, 5-535, 5-536, 5-537, 5-538, 5-539, 5-540, 5-541, 5-542, 5-543, 5-544, 5-545, 5-546, 5-547, 5-548, 5-549, 5-550, 5-551, 5-552, 5-553, 5-554, 5-555, 5-556, 5-557, 5-558, 5-559, 5-560, 5-561, 5-562, 5-563, 5-564, 5-565, 5-566, 5-567, 5-568, 5-569, 5-570, 5-571, 5-572, 5-573, 5-574, 5-575, 5-576, 5-577, 5-578, 5-579, 5-580, 5-581, 5-582, 5-583, 5-584, 5-585, 5-586, 5-587, 5-588, 5-589, 5-590, 5-591, 5-592, 5-593, 5-594, 5-595, 5-596, 5-597, 5-598, 5-599, 5-600, 5-601, 5-602, 5-603, 5-604, 5-605, 5-606, 5-607, 5-608, 5-609, 5-610, 5-611, 5-612, 5-613, 5-614, 5-615, 5-616, 5-617, 5-618, 5-619, 5-620, 5-621, 5-622, 5-623, 5-624, 5-625, 5-626, 5-627, 5-628, 5-629, 5-630, 5-631, 5-632, 5-633, 5-634, 5-635, 5-636, 5-637, 5-638, 5-639, 5-640, 5-641, 5-642, 5-643, 5-644, 5-645, 5-646, 5-647, 5-648, 5-649, 5-650, 5-651, 5-652, 5-653, 5-654, 5-655, 5-656, 5-657, 5-658, 5-659, 5-660, 5-661, 5-662, 5-663, 5-664, 5-665, 5-666, 5-667, 5-668, 5-669, 5-670, 5-671, 5-672, 5-673, 5-674, 5-675, 5-676, 5-677, 5-678, 5-679, 5-680, 5-681, 5-682, 5-683, 5-684, 5-685, 5-686, 5-687, 5-688, 5-689, 5-690, 5-691, 5-692, 5-693, 5-694, 5-695, 5-696, 5-697, 5-698, 5-699, 5-700, 5-701, 5-702, 5-703, 5-704, 5-705, 5-706, 5-707, 5-708, 5-709, 5-710, 5-711, 5-712, 5-713, 5-714, 5-715, 5-716, 5-717, 5-718, 5-719, 5-720, 5-721, 5-722, 5-723, 5-724, 5-725, 5-726, 5-727, 5-728, 5-729, 5-730, 5-731, 5-732, 5-733, 5-734, 5-735, 5-736, 5-737, 5-738, 5-739, 5-740, 5-741, 5-742, 5-743, 5-744, 5-745, 5-746, 5-747, 5-748, 5-749, 5-750, 5-751, 5-752, 5-753, 5-754, 5-755, 5-756, 5-757, 5-758, 5-759, 5-760, 5-761, 5-762, 5-763, 5-764, 5-765, 5-766, 5-767, 5-768, 5-769, 5-770, 5-771, 5-772, 5-773, 5-774, 5-775, 5-776, 5-777, 5-778, 5-779, 5-780, 5-781, 5-782, 5-783, 5-784, 5-785, 5-786, 5-787, 5-788, 5-789, 5-790, 5-791, 5-792, 5-793, 5-794, 5-795, 5-796, 5-797, 5-798, 5-799, 5-800, 5-801, 5-802, 5-803, 5-804, 5-805, 5-806, 5-807, 5-808, 5-809, 5-810, 5-811, 5-812, 5-813, 5-814, 5-815, 5-816, 5-817, 5-818, 5-819, 5-820, 5-821, 5-822, 5-823, 5-824, 5-825, 5-826, 5-827, 5-828, 5-829, 5-830, 5-831, 5-832, 5-833, 5-834, 5-835, 5-836, 5-837, 5-838, 5-839, 5-840, 5-841, 5-842, 5-843, 5-844, 5-845, 5-846, 5-847, 5-848, 5-849, 5-850, 5-851, 5-852, 5-853, 5-854, 5-855, 5-856, 5-857, 5-858, 5-859, 5-860, 5-861, 5-862, 5-863, 5-864, 5-865, 5-866, 5-867, 5-868, 5-869, 5-870, 5-871, 5-872, 5-873, 5-874, 5-875, 5-876, 5-877, 5-878, 5-879, 5-880, 5-881, 5-882, 5-883, 5-884, 5-885, 5-886, 5-887, 5-888, 5-889, 5-890, 5-891, 5-892, 5-893, 5-894, 5-895, 5-896, 5-897, 5-898, 5-899, 5-900, 5-901, 5-902, 5-903, 5-904, 5-905, 5-906, 5-907, 5-908, 5-909, 5-910, 5-911, 5-912, 5-913, 5-914, 5-915, 5-916, 5-917, 5-918, 5-919, 5-920, 5-921, 5-922, 5-923, 5-924, 5-925, 5-926, 5-927, 5-928, 5-929, 5-930, 5-931, 5-932, 5-933, 5-934, 5-935, 5-936, 5-937, 5-938, 5-939, 5-940, 5-941, 5-942, 5-943, 5-944, 5-945, 5-946, 5-947, 5-948, 5-949, 5-950, 5-951, 5-952, 5-953, 5-954, 5-955, 5-956, 5-957, 5-958, 5-959, 5-960, 5-961, 5-962, 5-963, 5-964, 5-965, 5-966, 5-967, 5-968, 5-969, 5-970, 5-971, 5-972, 5-973, 5-974, 5-975, 5-976, 5-977, 5-978, 5-979, 5-980, 5-981, 5-982, 5-983, 5-984, 5-985, 5-986, 5-987, 5-988, 5-989, 5-990, 5-991, 5-992, 5-993, 5-994, 5-995, 5-996, 5-997, 5-998, 5-999, 6000

