

工程指示 / 要求簡箋 ENGINEER INSTRUCTIONS (E.I.)

工程指示編號:	EI- 6563	修改版本:	-
	HK-1704		
工程編號:	J 853	工程名稱:	延坪道
收件人:	生統	發件人:	Joe Chan
工程項目:	T2, T3 幕牆室內收口	日期:	31/07/2023

<input checked="" type="checkbox"/> 原合約工程包	<input type="checkbox"/> 原合約工程加 / 減賬 QT-	<input type="checkbox"/> 新工程報價 QT-
--	--	------------------------------------

信件批核號碼/圖紙參考編號:	批核模具圖紙編號:
客戶指示附件:	管理內部批簽署:

<input type="checkbox"/> 初步鋁料 B.M.	<input type="checkbox"/> 加工拆圖, 然後生產	<input type="checkbox"/> 尺寸表
<input type="checkbox"/> 正式鋁料 B.M.	<input type="checkbox"/> 技術上資料/指示	<input type="checkbox"/> 報價
<input type="checkbox"/> 配件 B.M.	<input type="checkbox"/> 樣辦或貨品說明書	<input type="checkbox"/> 分判合約
<input type="checkbox"/> 其他:		

內容: 請依附件資料, 生產鋁板, 送地盤.

完成上列要求日期: 15/8/2023 ASAP

國內

<input type="checkbox"/> 生產技術總監	<input type="checkbox"/> 連附件	<input type="checkbox"/> 技術部	<input type="checkbox"/> 連附件	<input type="checkbox"/> 生產部	<input type="checkbox"/> 連附件
<input type="checkbox"/> 採購部	<input type="checkbox"/> 連附件	<input type="checkbox"/> 生產統籌部	<input type="checkbox"/> 連附件	<input type="checkbox"/> 報關組	<input type="checkbox"/> 連附件
<input type="checkbox"/> 質檢部	<input type="checkbox"/> 連附件	<input type="checkbox"/> 會計部	<input type="checkbox"/> 連附件	<input type="checkbox"/> 機械設計部	<input type="checkbox"/> 連附件
<input type="checkbox"/> 香港辦	<input type="checkbox"/> 連附件	<input type="checkbox"/> 其他:			

香港

<input type="checkbox"/> 行政部	<input type="checkbox"/> 連附件	<input type="checkbox"/> 會計部	<input type="checkbox"/> 連附件	<input type="checkbox"/> 統籌部	<input type="checkbox"/> 連附件	<input type="checkbox"/> 工程部	<input type="checkbox"/> 連附件
<input type="checkbox"/> 採購部	<input type="checkbox"/> 連附件	<input type="checkbox"/> QS部	<input type="checkbox"/> 連附件	<input checked="" type="checkbox"/> 地盤管理	<input checked="" type="checkbox"/> 連附件	<input type="checkbox"/> 維修部	<input type="checkbox"/> 連附件

炳哥

*發件人簽署:		*組別成員批核簽署:	
傳遞編號:	HK1704/23	項目經理簽署:	

①

圖則登記表  
DRAWING REGISTER

工程名稱 Project Title: 九龍延坪道 T2T3企/橫向室內收口鋁折件拆圖		年 月 日	接收日期 Receiving Date (適用於客戶圖則)						
工程編號 Project No: J-853									
分發予 Distributed To		年 月 日							
			23						
			4						
		20							
圖則編號 Drg. No.	圖則名稱 Drawing Title		修訂編號 Revision No.						
H-MA01-21	企向收口鋁板	1	-						
H-MA01-21(1)	企向收口鋁板(數據表)	2	-						
H-MB01-21	企向收口鋁板	3	-						
H-MB01-21(1)	企向收口鋁板(數據表)	4	-						
H-MC01-21	企向收口鋁板	5	-						
H-MC01-21(1)	企向收口鋁板(數據表)	6	-						
H-MD01-21	企向收口鋁板	7	-						
H-ME01-21	企向收口鋁板	8	-						
H-MF01-22	企向收口鋁板	9	-						
W-MA01-201	橫向收口鋁板	10	-						
W-MA01-201(1)	橫向收口鋁板(數據表)	11	-						
W-MB01-202	橫向收口鋁板	12	-						
W-MB01-202(1)	橫向收口鋁板(數據表)	13	-						
W-MC01-203	橫向收口鋁板	14	-						
W-MAFK01L-214	橫向收口鋁板	15	-						
W-MAFK01R-214	橫向收口鋁板	16	-						
W-MBFK01L-214	橫向收口鋁板	17	-						
W-MBFK01R-214	橫向收口鋁板	18	-						

2

圖則登記表  
DRAWING REGISTER

工程名稱 Project Title: 九龍延坪道 T2T3企/橫向室內收口鋁折件拆圖		年	接收日期 Receiving Date (適用於客戶圖則)						
工程編號 Project No: J-853			月						
分發予 Distributed To		日							
		年	23						
		月	4						
		日	20						
圖則編號 Drg. No.	圖則名稱 Drawing Title		修訂編號 Revision No.						
W-MA01-209	轉角橫向收口鋁板	19	-						
W-MA01-210	轉角橫向收口鋁板	20	-						
W-MC01-211	轉角橫向收口鋁板	21	-						
W-MC01-210	轉角橫向收口鋁板	22	-						
J853-SD-CW-4201	位置圖	23	-						
J853-SD-CW-4202	位置圖	24	-						
J853-SD-CW-4203	位置圖	25	-						
J853-SD-CW-4204	位置圖	26	-						
J853-SD-CW-4204A	位置圖	27	-						
J853-SD-CW-4205	位置圖	28	-						
J853-SD-CW-4206	位置圖	29	-						
J853-SD-CW-4301	位置圖	30	-						
J853-SD-CW-4302	位置圖	31	-						
J853-SD-CW-4303	位置圖	32	-						
J853-SD-CW-4304	位置圖	33	-						
J853-SD-CW-4304A	位置圖	34	-						
J853-SD-CW-4305	位置圖	35	-						
J853-SD-CW-4306	位置圖	36	-						

美特鋁質有限公司 MIDI Aluminium Fabricator Ltd.		工程號: J-853	計算: 方強	日期: 2023.04.10	送呈: 胡哥								
地盤名稱: 九龍延坪道		核對: 謝永林	日期: 2023.04.20	副本:									
項目類別: T2T3單元件		批准:	日期:										
修改版次:		A/C Code:	總V.F.:	總重量: 1180.99	此BM依據拆圖資料計算								
序號	修改內容	鋁板圖號	鋁板名稱	顏色	實用	後備	總數	總重量	單件展開面積	總展開面積	單件V.F.	總V.F.	備註
					平方米	平方米		平方米					
1		H-MA01-21	企向收口鋁板	EC-DG-D334232-ZD1 (閃粉古銅)	6		6	6.123	0.188	1.130	0.19	1.14	
2		H-MA01-22	企向收口鋁板	EC-DG-D334232-ZD1 (閃粉古銅)	1		1	1.047	0.193	0.193	0.20	0.20	
3		H-MA01-23	企向收口鋁板	EC-DG-D334232-ZD1 (閃粉古銅)	1		1	1.090	0.201	0.201	0.20	0.20	
4		H-MA01-24	企向收口鋁板	EC-DG-D334232-ZD1 (閃粉古銅)	1		1	1.136	0.210	0.210	0.21	0.21	
5		H-MA01-21	企向收口鋁板	EC-DG-D334232-ZD1 (閃粉古銅)	28		28	28.573	0.188	5.272	0.19	5.34	
6		H-MA01-23	企向收口鋁板	EC-DG-D334232-ZD1 (閃粉古銅)	4		4	4.358	0.201	0.804	0.20	0.81	
7		H-MA01-25	企向收口鋁板	EC-DG-D334232-ZD1 (閃粉古銅)	2		2	1.991	0.184	0.367	0.19	0.37	
8		H-MA01-21	企向收口鋁板	EC-DG-D334232-ZD1 (閃粉古銅)	16		16	16.327	0.188	3.012	0.19	3.05	
9		H-MA01-23	企向收口鋁板	EC-DG-D334232-ZD1 (閃粉古銅)	4		4	4.358	0.201	0.804	0.20	0.81	
10		H-MA01-21	企向收口鋁板	EC-DG-D334232-ZD1 (閃粉古銅)	6		6	6.123	0.188	1.130	0.19	1.14	
11		H-MA01-24	企向收口鋁板	EC-DG-D334232-ZD1 (閃粉古銅)	1		1	1.136	0.210	0.210	0.21	0.21	
12		H-MA01-23	企向收口鋁板	EC-DG-D334232-ZD1 (閃粉古銅)	2		2	2.179	0.201	0.402	0.20	0.41	
13		H-MA01-22	企向收口鋁板	EC-DG-D334232-ZD1 (閃粉古銅)	2		2	2.094	0.193	0.386	0.20	0.39	
14		H-MA01-21	企向收口鋁板	EC-DG-D334232-ZD1 (閃粉古銅)	6		6	6.123	0.188	1.130	0.19	1.14	
15		H-MA01-25	企向收口鋁板	EC-DG-D334232-ZD1 (閃粉古銅)	1		1	0.995	0.184	0.184	0.19	0.19	
16		H-MA01-21	企向收口鋁板	EC-DG-D334232-ZD1 (閃粉古銅)	14		14	14.286	0.188	2.636	0.19	2.67	
17		H-MA01-23	企向收口鋁板	EC-DG-D334232-ZD1 (閃粉古銅)	3		3	3.269	0.201	0.603	0.20	0.61	
18		H-MA01-24	企向收口鋁板	EC-DG-D334232-ZD1 (閃粉古銅)	1		1	1.136	0.210	0.210	0.21	0.21	
19		H-MA01-22	企向收口鋁板	EC-DG-D334232-ZD1 (閃粉古銅)	1		1	1.047	0.193	0.193	0.20	0.20	
20		H-MA01-21	企向收口鋁板	EC-DG-D334232-ZD1 (閃粉古銅)	14		14	14.286	0.188	2.636	0.19	2.67	
21		H-MA01-23	企向收口鋁板	EC-DG-D334232-ZD1 (閃粉古銅)	3		3	3.269	0.201	0.603	0.20	0.61	
22		H-MA01-24	企向收口鋁板	EC-DG-D334232-ZD1 (閃粉古銅)	1		1	1.136	0.210	0.210	0.21	0.21	
23		H-MA01-22	企向收口鋁板	EC-DG-D334232-ZD1 (閃粉古銅)	1		1	1.047	0.193	0.193	0.20	0.20	
24		H-MA01-22	企向收口鋁板	EC-DG-D334232-ZD1 (閃粉古銅)	1		1	1.047	0.193	0.193	0.20	0.20	
25		H-MA01-21	企向收口鋁板	EC-DG-D334232-ZD1 (閃粉古銅)	6		6	6.123	0.188	1.130	0.19	1.14	
26		H-MA01-25	企向收口鋁板	EC-DG-D334232-ZD1 (閃粉古銅)	1		1	0.995	0.184	0.184	0.19	0.19	
27		H-MA01-21	企向收口鋁板	EC-DG-D334232-ZD1 (閃粉古銅)	6		6	6.123	0.188	1.130	0.19	1.14	
28		H-MA01-22	企向收口鋁板	EC-DG-D334232-ZD1 (閃粉古銅)	1		1	1.047	0.193	0.193	0.20	0.20	
29		H-MA01-23	企向收口鋁板	EC-DG-D334232-ZD1 (閃粉古銅)	1		1	1.090	0.201	0.201	0.20	0.20	
30		H-MA01-24	企向收口鋁板	EC-DG-D334232-ZD1 (閃粉古銅)	1		1	1.136	0.210	0.210	0.21	0.21	

美特鋁質有限公司 MIDI Aluminium Fabricator Ltd.		工程號: J-853	計算: 方強	日期: 2023.04.10	送呈: 胡哥								
地盤名稱: 九龍延坪道 <td></td> <th>核對: 謝永林</th> <th>日期: 2023.04.20</th> <th>副本:</th>			核對: 謝永林	日期: 2023.04.20	副本:								
項目類別: T2T3單元件 <td></td> <th>批准:</th> <td></td> <td></td>			批准:										
修改版次: <td></td> <th>A/C Code:</th> <th>總V.F.:</th> <th>總重量: 1180.99</th>			A/C Code:	總V.F.:	總重量: 1180.99								
				221.42	此BM依據拆圖 資料計算								
序號	修改內容	鋁板圖號	鋁板名稱	顏色	實用	後備	總數	總重量	單件展開面積	總展開面積	單件V.F.	總V.F.	備註
									平方米	平方米	平方米	平方米	
31		H-MA01-21	企向收口鋁板	EC-DG-D334232-ZD1 (閃粉古銅)	28		28	28.573	0.188	5.272	0.19	5.34	
32		H-MA01-23	企向收口鋁板	EC-DG-D334232-ZD1 (閃粉古銅)	4		4	4.358	0.201	0.804	0.20	0.81	
33		H-MA01-25	企向收口鋁板	EC-DG-D334232-ZD1 (閃粉古銅)	2		2	1.991	0.184	0.367	0.19	0.37	
34		H-MA01-21	企向收口鋁板	EC-DG-D334232-ZD1 (閃粉古銅)	16		16	16.327	0.188	3.012	0.19	3.05	
35		H-MA01-23	企向收口鋁板	EC-DG-D334232-ZD1 (閃粉古銅)	4		4	4.358	0.201	0.804	0.20	0.81	
36		H-MA01-21	企向收口鋁板	EC-DG-D334232-ZD1 (閃粉古銅)	6		6	6.123	0.188	1.130	0.19	1.14	
37		H-MA01-24	企向收口鋁板	EC-DG-D334232-ZD1 (閃粉古銅)	1		1	1.136	0.210	0.210	0.21	0.21	
38		H-MA01-23	企向收口鋁板	EC-DG-D334232-ZD1 (閃粉古銅)	2		2	2.179	0.201	0.402	0.20	0.41	
39		H-MA01-22	企向收口鋁板	EC-DG-D334232-ZD1 (閃粉古銅)	2		2	2.094	0.193	0.386	0.20	0.39	
40		H-MA01-21	企向收口鋁板	EC-DG-D334232-ZD1 (閃粉古銅)	14		14	14.286	0.188	2.636	0.19	2.67	
41		H-MA01-23	企向收口鋁板	EC-DG-D334232-ZD1 (閃粉古銅)	3		3	3.269	0.201	0.603	0.20	0.61	
42		H-MA01-24	企向收口鋁板	EC-DG-D334232-ZD1 (閃粉古銅)	1		1	1.136	0.210	0.210	0.21	0.21	
43		H-MA01-22	企向收口鋁板	EC-DG-D334232-ZD1 (閃粉古銅)	1		1	1.047	0.193	0.193	0.20	0.20	
44		H-MA01-21	企向收口鋁板	EC-DG-D334232-ZD1 (閃粉古銅)	14		14	14.286	0.188	2.636	0.19	2.67	
45		H-MA01-23	企向收口鋁板	EC-DG-D334232-ZD1 (閃粉古銅)	3		3	3.269	0.201	0.603	0.20	0.61	
46		H-MA01-24	企向收口鋁板	EC-DG-D334232-ZD1 (閃粉古銅)	1		1	1.136	0.210	0.210	0.21	0.21	
47		H-MA01-22	企向收口鋁板	EC-DG-D334232-ZD1 (閃粉古銅)	1		1	1.047	0.193	0.193	0.20	0.20	
48		H-MA01-22	企向收口鋁板	EC-DG-D334232-ZD1 (閃粉古銅)	1		1	1.047	0.193	0.193	0.20	0.20	
49		H-MA01-22	企向收口鋁板	EC-DG-D334232-ZD1 (閃粉古銅)	1		1	1.047	0.193	0.193	0.20	0.20	
50		H-MB01-21	企向收口鋁板	EC-DG-D334232-ZD1 (閃粉古銅)	8		8	6.723	0.155	1.240	0.16	1.26	
51		H-MB01-23	企向收口鋁板	EC-DG-D334232-ZD1 (閃粉古銅)	2		2	1.795	0.166	0.331	0.17	0.34	
52		H-MB01-21	企向收口鋁板	EC-DG-D334232-ZD1 (閃粉古銅)	6		6	5.042	0.155	0.930	0.16	0.94	
53		H-MB01-25	企向收口鋁板	EC-DG-D334232-ZD1 (閃粉古銅)	1		1	0.820	0.151	0.151	0.15	0.15	
54		H-MB01-21	企向收口鋁板	EC-DG-D334232-ZD1 (閃粉古銅)	28		28	23.530	0.155	4.341	0.16	4.40	
55		H-MB01-23	企向收口鋁板	EC-DG-D334232-ZD1 (閃粉古銅)	6		6	5.384	0.166	0.993	0.17	1.01	
56		H-MB01-24	企向收口鋁板	EC-DG-D334232-ZD1 (閃粉古銅)	2		2	1.870	0.173	0.345	0.17	0.35	
57		H-MB01-22	企向收口鋁板	EC-DG-D334232-ZD1 (閃粉古銅)	2		2	1.724	0.159	0.318	0.16	0.32	
58		H-MB01-22	企向收口鋁板	EC-DG-D334232-ZD1 (閃粉古銅)	1		1	0.862	0.159	0.159	0.16	0.16	
59		H-MB01-21	企向收口鋁板	EC-DG-D334232-ZD1 (閃粉古銅)	8		8	6.723	0.155	1.240	0.16	1.26	
60		H-MB01-23	企向收口鋁板	EC-DG-D334232-ZD1 (閃粉古銅)	2		2	1.795	0.166	0.331	0.17	0.34	

5

 <b>美特鋁質</b> MIDI Aluminium Fabricator Ltd.	工程號: J-853	計算: 方強	日期: 2023.04.10	送呈: 胡哥
	地盤名稱: 九龍延坪道	核對: 謝永林	日期: 2023.04.20	副本:
	項目類別: T2T3單元件	批准:		
	修改版次:	A/C Code:	總V.F.:: 221.42	總重量: 1180.99

此BM依據拆圖資料計算

序號	修改內容	鋁板圖號	鋁板名稱	顏色	實用	後備	總數	總重量	單件展開面積		備註	
									平方米	平方米		
61		H-MB01-21	企向收口鋁板	EC-DG-D334232-ZD1 (閃粉古銅)	6		6	5.042	0.155	0.930	0.16	0.94
62		H-MB01-25	企向收口鋁板	EC-DG-D334232-ZD1 (閃粉古銅)	1		1	0.820	0.151	0.151	0.15	0.15
63		H-MB01-21	企向收口鋁板	EC-DG-D334232-ZD1 (閃粉古銅)	28		28	23.530	0.155	4.341	0.16	4.40
64		H-MB01-23	企向收口鋁板	EC-DG-D334232-ZD1 (閃粉古銅)	6		6	5.384	0.166	0.993	0.17	1.01
65		H-MB01-24	企向收口鋁板	EC-DG-D334232-ZD1 (閃粉古銅)	2		2	1.870	0.173	0.345	0.17	0.35
66		H-MB01-22	企向收口鋁板	EC-DG-D334232-ZD1 (閃粉古銅)	2		2	1.724	0.159	0.318	0.16	0.32
67		H-MB01-22	企向收口鋁板	EC-DG-D334232-ZD1 (閃粉古銅)	1		1	0.862	0.159	0.159	0.16	0.16
68		H-MC01-21	企向收口鋁板	EC-DG-D334232-ZD1 (閃粉古銅)	16		16	11.813	0.136	2.180	0.14	2.21
69		H-MC01-23	企向收口鋁板	EC-DG-D334232-ZD1 (閃粉古銅)	4		4	3.153	0.145	0.582	0.15	0.59
70		H-MC01-21	企向收口鋁板	EC-DG-D334232-ZD1 (閃粉古銅)	28		28	20.673	0.136	3.814	0.14	3.87
71		H-MC01-23	企向收口鋁板	EC-DG-D334232-ZD1 (閃粉古銅)	6		6	4.730	0.145	0.873	0.15	0.88
72		H-MC01-24	企向收口鋁板	EC-DG-D334232-ZD1 (閃粉古銅)	2		2	1.643	0.152	0.303	0.15	0.31
73		H-MC01-22	企向收口鋁板	EC-DG-D334232-ZD1 (閃粉古銅)	2		2	1.515	0.140	0.280	0.14	0.28
74		H-MC01-21	企向收口鋁板	EC-DG-D334232-ZD1 (閃粉古銅)	56		56	41.346	0.136	7.628	0.14	7.73
75		H-MC01-23	企向收口鋁板	EC-DG-D334232-ZD1 (閃粉古銅)	12		12	9.460	0.145	1.745	0.15	1.77
76		H-MC01-24	企向收口鋁板	EC-DG-D334232-ZD1 (閃粉古銅)	4		4	3.287	0.152	0.606	0.15	0.61
77		H-MC01-22	企向收口鋁板	EC-DG-D334232-ZD1 (閃粉古銅)	4		4	3.030	0.140	0.559	0.14	0.57
78		H-MC01-21	企向收口鋁板	EC-DG-D334232-ZD1 (閃粉古銅)	28		28	20.673	0.136	3.814	0.14	3.87
79		H-MC01-23	企向收口鋁板	EC-DG-D334232-ZD1 (閃粉古銅)	6		6	4.730	0.145	0.873	0.15	0.88
80		H-MC01-24	企向收口鋁板	EC-DG-D334232-ZD1 (閃粉古銅)	2		2	1.643	0.152	0.303	0.15	0.31
81		H-MC01-22	企向收口鋁板	EC-DG-D334232-ZD1 (閃粉古銅)	2		2	1.515	0.140	0.280	0.14	0.28
82		H-MC01-21	企向收口鋁板	EC-DG-D334232-ZD1 (閃粉古銅)	16		16	11.813	0.136	2.180	0.14	2.21
83		H-MC01-23	企向收口鋁板	EC-DG-D334232-ZD1 (閃粉古銅)	2		2	1.577	0.145	0.291	0.15	0.29
84		H-MC01-22	企向收口鋁板	EC-DG-D334232-ZD1 (閃粉古銅)	2		2	1.515	0.140	0.280	0.14	0.28
85		H-MC01-21	企向收口鋁板	EC-DG-D334232-ZD1 (閃粉古銅)	16		16	11.813	0.136	2.180	0.14	2.21
86		H-MC01-23	企向收口鋁板	EC-DG-D334232-ZD1 (閃粉古銅)	4		4	3.153	0.145	0.582	0.15	0.59
87		H-MC01-21	企向收口鋁板	EC-DG-D334232-ZD1 (閃粉古銅)	28		28	20.673	0.136	3.814	0.14	3.87
88		H-MC01-23	企向收口鋁板	EC-DG-D334232-ZD1 (閃粉古銅)	6		6	4.730	0.145	0.873	0.15	0.88
89		H-MC01-24	企向收口鋁板	EC-DG-D334232-ZD1 (閃粉古銅)	2		2	1.643	0.152	0.303	0.15	0.31
90		H-MC01-22	企向收口鋁板	EC-DG-D334232-ZD1 (閃粉古銅)	2		2	1.515	0.140	0.280	0.14	0.28

6

 <b>美特鋁質</b> 有限公司 MIDI Aluminum Fabricator Ltd.	工程號: J-853	計算: 方強	日期: 2023.04.10	送呈: 胡哥
	地盤名稱: 九龍延坪道	核對: 謝永林	日期: 2023.04.20	副本:
	項目類別: T2T3單元件	批准:	日期:	
	修改版次:	A/C Code:	總V.F.: 221.42	總重量: 1180.99

此BM依據拆圖資料計算

序號	修改內容	鋁板圖號	鋁板名稱	顏色	實用	後備	總數	總重量	單件展開面積		單件V.F.	總V.F.	備註
									平方米	平方米			
91		H-MC01-21	企向收口鋁板	EC-DG-D334232-ZD1 (閃粉古銅)	56		56	41.346	0.136	7.628	0.14	7.73	
92		H-MC01-23	企向收口鋁板	EC-DG-D334232-ZD1 (閃粉古銅)	12		12	9.460	0.145	1.745	0.15	1.77	
93		H-MC01-24	企向收口鋁板	EC-DG-D334232-ZD1 (閃粉古銅)	4		4	3.287	0.152	0.606	0.15	0.61	
94		H-MC01-22	企向收口鋁板	EC-DG-D334232-ZD1 (閃粉古銅)	4		4	3.030	0.140	0.559	0.14	0.57	
95		H-MC01-21	企向收口鋁板	EC-DG-D334232-ZD1 (閃粉古銅)	28		28	20.673	0.136	3.814	0.14	3.87	
96		H-MC01-23	企向收口鋁板	EC-DG-D334232-ZD1 (閃粉古銅)	6		6	4.730	0.145	0.873	0.15	0.88	
97		H-MC01-24	企向收口鋁板	EC-DG-D334232-ZD1 (閃粉古銅)	2		2	1.643	0.152	0.303	0.15	0.31	
98		H-MC01-22	企向收口鋁板	EC-DG-D334232-ZD1 (閃粉古銅)	2		2	1.515	0.140	0.280	0.14	0.28	
99		H-MC01-21	企向收口鋁板	EC-DG-D334232-ZD1 (閃粉古銅)	16		16	11.813	0.136	2.180	0.14	2.21	
100		H-MC01-23	企向收口鋁板	EC-DG-D334232-ZD1 (閃粉古銅)	2		2	1.577	0.145	0.291	0.15	0.29	
101		H-MC01-22	企向收口鋁板	EC-DG-D334232-ZD1 (閃粉古銅)	2		2	1.515	0.140	0.280	0.14	0.28	
102		H-MD01-21	企向收口鋁板	EC-DG-D334232-ZD1 (閃粉古銅)	14		14	24.623	0.324	4.543	0.33	4.60	
103		H-MD01-22	企向收口鋁板	EC-DG-D334232-ZD1 (閃粉古銅)	1		1	1.804	0.333	0.333	0.34	0.34	
104		H-MD01-23	企向收口鋁板	EC-DG-D334232-ZD1 (閃粉古銅)	3		3	5.634	0.346	1.039	0.35	1.05	
105		H-MD01-24	企向收口鋁板	EC-DG-D334232-ZD1 (閃粉古銅)	1		1	1.957	0.361	0.361	0.37	0.37	
106		H-ME01-21	企向收口鋁板	EC-DG-D334232-ZD1 (閃粉古銅)	14		14	28.825	0.380	5.318	0.39	5.39	
107		H-ME01-22	企向收口鋁板	EC-DG-D334232-ZD1 (閃粉古銅)	1		1	2.112	0.390	0.390	0.39	0.39	
108		H-ME01-23	企向收口鋁板	EC-DG-D334232-ZD1 (閃粉古銅)	3		3	6.595	0.406	1.217	0.41	1.23	
109		H-ME01-24	企向收口鋁板	EC-DG-D334232-ZD1 (閃粉古銅)	1		1	2.291	0.423	0.423	0.43	0.43	
110		H-MF01-22	企向收口鋁板	EC-DG-D334232-ZD1 (閃粉古銅)	1		1	2.094	0.386	0.386	0.39	0.39	
111		W-MA01-201	橫向收口鋁板	EC-DG-D334232-ZD1 (閃粉古銅)	10		10	6.932	0.128	1.279	0.13	1.31	
112		W-MA01-202	橫向收口鋁板	EC-DG-D334232-ZD1 (閃粉古銅)	8		8	11.243	0.259	2.074	0.26	2.10	
113		W-MA01-203	橫向收口鋁板	EC-DG-D334232-ZD1 (閃粉古銅)	16		16	13.959	0.161	2.575	0.16	2.63	
114		W-MA01-204	橫向收口鋁板	EC-DG-D334232-ZD1 (閃粉古銅)	10		10	10.790	0.199	1.991	0.20	2.02	
115		W-MA01-205	橫向收口鋁板	EC-DG-D334232-ZD1 (閃粉古銅)	10		10	7.971	0.147	1.471	0.15	1.50	
116		W-MA01-206	橫向收口鋁板	EC-DG-D334232-ZD1 (閃粉古銅)	7		7	8.600	0.227	1.587	0.23	1.61	
117		W-MA01-207	橫向收口鋁板	EC-DG-D334232-ZD1 (閃粉古銅)	1		1	1.445	0.267	0.267	0.27	0.27	
118		W-MA01-208	橫向收口鋁板	EC-DG-D334232-ZD1 (閃粉古銅)	1		1	0.496	0.091	0.091	0.09	0.09	
119		W-MA01-212	橫向收口鋁板	EC-DG-D334232-ZD1 (閃粉古銅)	18		18	15.415	0.158	2.844	0.16	2.90	
120		W-MA01-213	橫向收口鋁板	EC-DG-D334232-ZD1 (閃粉古銅)	18		18	15.949	0.163	2.943	0.17	3.00	

	工程號: J-853	計算: 方強	日期: 2023.04.10	送呈: 胡哥
	地盤名稱: 九龍延坪道	核對: 謝永林	日期: 2023.04.20	副本:
	項目類別: T2T3單元件	批准:		
	修改版次:	A/C Code:	總V.F.: 221.42	總重量: 1180.99

此BM依據拆圖資料計算

序號	修改內容	鋁板圖號	鋁板名稱	顏色	實用	後備	總數	總重量	單件展開面積		單件V.F.		備註
									平方米	平方呎	平方米	平方呎	
121		W-MA01-215	橫向收口鋁板	EC-DG-D334232-ZD1 (閃粉古銅)	36		36	47.389	0.243	8.743	0.25	8.86	
122		W-MA01-216	橫向收口鋁板	EC-DG-D334232-ZD1 (閃粉古銅)	18		18	17.552	0.180	3.238	0.18	3.30	
123		W-MA01-212	橫向收口鋁板	EC-DG-D334232-ZD1 (閃粉古銅)	18		18	15.415	0.158	2.844	0.16	2.90	
124		W-MA01-223	橫向收口鋁板	EC-DG-D334232-ZD1 (閃粉古銅)	1		1	1.418	0.262	0.262	0.26	0.26	
125		W-MA01-224	橫向收口鋁板	EC-DG-D334232-ZD1 (閃粉古銅)	1		1	0.407	0.075	0.075	0.08	0.08	
126		W-MA01-304	橫向收口鋁板	EC-DG-D334232-ZD1 (閃粉古銅)	10		10	6.932	0.128	1.279	0.13	1.31	
127		W-MA01-305	橫向收口鋁板	EC-DG-D334232-ZD1 (閃粉古銅)	8		8	11.243	0.259	2.074	0.26	2.10	
128		W-MA01-306	橫向收口鋁板	EC-DG-D334232-ZD1 (閃粉古銅)	16		16	13.959	0.161	2.575	0.16	2.63	
129		W-MA01-307	橫向收口鋁板	EC-DG-D334232-ZD1 (閃粉古銅)	1		1	1.020	0.188	0.188	0.19	0.19	
130		W-MA01-308	橫向收口鋁板	EC-DG-D334232-ZD1 (閃粉古銅)	1		1	0.871	0.161	0.161	0.16	0.16	
131		W-MA01-309	橫向收口鋁板	EC-DG-D334232-ZD1 (閃粉古銅)	9		9	9.844	0.202	1.816	0.21	1.85	
132		W-MA01-310	橫向收口鋁板	EC-DG-D334232-ZD1 (閃粉古銅)	9		9	7.174	0.147	1.324	0.15	1.35	
133		W-MA01-311	橫向收口鋁板	EC-DG-D334232-ZD1 (閃粉古銅)	7		7	8.704	0.229	1.606	0.23	1.63	
134		W-MA01-312	橫向收口鋁板	EC-DG-D334232-ZD1 (閃粉古銅)	1		1	1.460	0.269	0.269	0.27	0.27	
135		W-MA01-313	橫向收口鋁板	EC-DG-D334232-ZD1 (閃粉古銅)	1		1	0.496	0.091	0.091	0.09	0.09	
136		W-MA01-314	橫向收口鋁板	EC-DG-D334232-ZD1 (閃粉古銅)	18		18	15.415	0.158	2.844	0.16	2.90	
137		W-MA01-315	橫向收口鋁板	EC-DG-D334232-ZD1 (閃粉古銅)	18		18	17.552	0.180	3.238	0.18	3.30	
138		W-MA01-317	橫向收口鋁板	EC-DG-D334232-ZD1 (閃粉古銅)	36		36	47.389	0.243	8.743	0.25	8.86	
139		W-MA01-318	橫向收口鋁板	EC-DG-D334232-ZD1 (閃粉古銅)	18		18	17.552	0.180	3.238	0.18	3.30	
140		W-MA01-319	橫向收口鋁板	EC-DG-D334232-ZD1 (閃粉古銅)	18		18	15.949	0.163	2.943	0.17	3.00	
141		W-MA01-324	橫向收口鋁板	EC-DG-D334232-ZD1 (閃粉古銅)	1		1	1.315	0.243	0.243	0.25	0.25	
142		W-MA01-325	橫向收口鋁板	EC-DG-D334232-ZD1 (閃粉古銅)	1		1	0.407	0.075	0.075	0.08	0.08	
143		W-MB01-202	橫向收口鋁板	EC-DG-D334232-ZD1 (閃粉古銅)	1		1	0.898	0.166	0.166	0.17	0.17	
144		W-MB01-207	橫向收口鋁板	EC-DG-D334232-ZD1 (閃粉古銅)	1		1	0.924	0.170	0.170	0.17	0.17	
145		W-MB01-208	橫向收口鋁板	EC-DG-D334232-ZD1 (閃粉古銅)	1		1	0.317	0.058	0.058	0.06	0.06	
146		W-MB01-212	橫向收口鋁板	EC-DG-D334232-ZD1 (閃粉古銅)	1		1	0.547	0.101	0.101	0.10	0.10	
147		W-MB01-213	橫向收口鋁板	EC-DG-D334232-ZD1 (閃粉古銅)	1		1	0.566	0.105	0.105	0.11	0.11	
148		W-MB01-215	橫向收口鋁板	EC-DG-D334232-ZD1 (閃粉古銅)	2		2	1.683	0.155	0.311	0.16	0.31	
149		W-MB01-216	橫向收口鋁板	EC-DG-D334232-ZD1 (閃粉古銅)	1		1	0.623	0.115	0.115	0.12	0.12	
150		W-MB01-212	橫向收口鋁板	EC-DG-D334232-ZD1 (閃粉古銅)	1		1	0.547	0.101	0.101	0.10	0.10	

82

美特鋁質 MIDI Aluminium Fabricator Ltd.		工程號: J-853	計算: 方強	日期: 2023.04.10	送呈: 胡哥								
地盤名稱: 九龍延坪道			核對: 謝永林	日期: 2023.04.20	副本:								
項目類別: T2T3單元件			批准:										
修改版次:		A/C Code:	總V.F.:	221.42	總重量: 1180.99								
此BM依據拆圖資料計算													
序號	修改內容	鋁板圖號	鋁板名稱	顏色	實用	後備	總數	總重量	單件展開面積		備註		
									單件展開面積	總V.F.			
									平方米		平方米		
151		W-MB01-221	橫向收口鋁板	EC-DG-D334232-ZD1(閃粉古銅)	1		1	0.901	0.166	0.166	0.17	0.17	
152		W-MB01-222	橫向收口鋁板	EC-DG-D334232-ZD1(閃粉古銅)	1		1	0.254	0.047	0.047	0.05	0.05	
153		W-MB01-225	橫向收口鋁板	EC-DG-D334232-ZD1(閃粉古銅)	1		1	0.860	0.159	0.159	0.16	0.16	
154		W-MB01-226	橫向收口鋁板	EC-DG-D334232-ZD1(閃粉古銅)	1		1	0.756	0.140	0.140	0.14	0.14	
155		W-MB01-305	橫向收口鋁板	EC-DG-D334232-ZD1(閃粉古銅)	1		1	0.898	0.166	0.166	0.17	0.17	
156		W-MB01-312	橫向收口鋁板	EC-DG-D334232-ZD1(閃粉古銅)	1		1	0.933	0.172	0.172	0.17	0.17	
157		W-MB01-313	橫向收口鋁板	EC-DG-D334232-ZD1(閃粉古銅)	1		1	0.317	0.058	0.058	0.06	0.06	
158		W-MB01-314	橫向收口鋁板	EC-DG-D334232-ZD1(閃粉古銅)	1		1	0.547	0.101	0.101	0.10	0.10	
159		W-MB01-315	橫向收口鋁板	EC-DG-D334232-ZD1(閃粉古銅)	1		1	0.623	0.115	0.115	0.12	0.12	
160		W-MB01-317	橫向收口鋁板	EC-DG-D334232-ZD1(閃粉古銅)	2		2	1.683	0.155	0.311	0.16	0.31	
161		W-MB01-318	橫向收口鋁板	EC-DG-D334232-ZD1(閃粉古銅)	1		1	0.623	0.115	0.115	0.12	0.12	
162		W-MB01-319	橫向收口鋁板	EC-DG-D334232-ZD1(閃粉古銅)	1		1	0.566	0.105	0.105	0.11	0.11	
163		W-MB01-322	橫向收口鋁板	EC-DG-D334232-ZD1(閃粉古銅)	1		1	0.835	0.154	0.154	0.16	0.16	
164		W-MB01-323	橫向收口鋁板	EC-DG-D334232-ZD1(閃粉古銅)	1		1	0.254	0.047	0.047	0.05	0.05	
165		W-MB01-326	橫向收口鋁板	EC-DG-D334232-ZD1(閃粉古銅)	1		1	0.851	0.157	0.157	0.16	0.16	
166		W-MB01-327	橫向收口鋁板	EC-DG-D334232-ZD1(閃粉古銅)	1		1	0.756	0.140	0.140	0.14	0.14	
167		W-MC01-203	橫向收口鋁板	EC-DG-D334232-ZD1(閃粉古銅)	1		1	0.610	0.112	0.112	0.11	0.11	
168		W-MC01-306	橫向收口鋁板	EC-DG-D334232-ZD1(閃粉古銅)	1		1	0.610	0.112	0.112	0.11	0.11	
169		W-MAFK01L-	橫向收口鋁板	EC-DG-D334232-ZD1(閃粉古銅)	18		18	8.471	0.087	1.563	0.09	1.62	
170		W-MAFK01L-	橫向收口鋁板	EC-DG-D334232-ZD1(閃粉古銅)	9		9	5.478	0.112	1.011	0.12	1.04	
171		W-MAFK01L-	橫向收口鋁板	EC-DG-D334232-ZD1(閃粉古銅)	18		18	8.471	0.087	1.563	0.09	1.62	
172		W-MAFK01L-	橫向收口鋁板	EC-DG-D334232-ZD1(閃粉古銅)	9		9	5.344	0.110	0.986	0.11	1.02	
173		W-MAFK01R-	橫向收口鋁板	EC-DG-D334232-ZD1(閃粉古銅)	18		18	8.471	0.087	1.563	0.09	1.62	
174		W-MAFK01R-	橫向收口鋁板	EC-DG-D334232-ZD1(閃粉古銅)	9		9	2.540	0.052	0.469	0.06	0.50	
175		W-MAFK01R-	橫向收口鋁板	EC-DG-D334232-ZD1(閃粉古銅)	18		18	8.471	0.087	1.563	0.09	1.62	
176		W-MAFK01R-	橫向收口鋁板	EC-DG-D334232-ZD1(閃粉古銅)	9		9	2.540	0.052	0.469	0.06	0.50	
177		W-MBFFK01L-	橫向收口鋁板	EC-DG-D334232-ZD1(閃粉古銅)	1		1	0.329	0.061	0.061	0.06	0.06	
178		W-MBFFK01L-	橫向收口鋁板	EC-DG-D334232-ZD1(閃粉古銅)	1		1	0.329	0.061	0.061	0.06	0.06	
179		W-MBFFK01R-	橫向收口鋁板	EC-DG-D334232-ZD1(閃粉古銅)	1		1	0.329	0.061	0.061	0.06	0.06	
180		W-MBFFK01R-	橫向收口鋁板	EC-DG-D334232-ZD1(閃粉古銅)	1		1	0.329	0.061	0.061	0.06	0.06	

美特鋁質有限公司 MIDI Aluminium Fabricator Ltd.		工程號: J-853		計算: 方強		日期: 2023.04.10		送呈: 胡哥																	
地盤名稱: 九龍延坪道		核對: 謝永林		日期: 2023.04.20		日期: 2023.04.20		副本:																	
項目類別: T2T3單元件		批准:		日期:		日期:		日期:																	
修改版次:		A/C Code:		總V.F.:		總重量: 1180.99		總重量: 1180.99																	
修改內容		鋁板圖號		鋁板名稱		顏色		實用		後備		總數		總重量		單件展開面積		總展開面積		單件V.F.		總V.F.		備註	
序號	修改內容	鋁板圖號	鋁板名稱	顏色	實用	後備	總數	總重量	單件展開面積	總展開面積	單件V.F.	總V.F.	備註												
										平方米		平方米		平方米		平方米		平方米							
181		W-MA01-209	橫向收口鋁板	EC-DG-D334232-ZD1 (閃粉古銅)	10		10	7.775	0.143	1.434	0.15	1.47													
182		W-MA01-211	橫向收口鋁板	EC-DG-D334232-ZD1 (閃粉古銅)	6		6	8.938	0.275	1.649	0.28	1.67													
183		W-MA01-301	橫向收口鋁板	EC-DG-D334232-ZD1 (閃粉古銅)	10		10	7.775	0.143	1.434	0.15	1.47													
184		W-MA01-303	橫向收口鋁板	EC-DG-D334232-ZD1 (閃粉古銅)	6		6	8.938	0.275	1.649	0.28	1.67													
185		W-MA01-210	橫向收口鋁板	EC-DG-D334232-ZD1 (閃粉古銅)	10		10	4.214	0.078	0.777	0.08	0.81													
186		W-MA01-210	橫向收口鋁板	EC-DG-D334232-ZD1 (閃粉古銅)	6		6	2.528	0.078	0.466	0.08	0.49													
187		W-MA01-302	橫向收口鋁板	EC-DG-D334232-ZD1 (閃粉古銅)	10		10	4.214	0.078	0.777	0.08	0.81													
188		W-MA01-302	橫向收口鋁板	EC-DG-D334232-ZD1 (閃粉古銅)	6		6	2.528	0.078	0.466	0.08	0.49													
189		W-MC01-211	橫向收口鋁板	EC-DG-D334232-ZD1 (閃粉古銅)	1		1	1.041	0.192	0.192	0.19	0.19													
190		W-MC01-303	橫向收口鋁板	EC-DG-D334232-ZD1 (閃粉古銅)	1		1	1.041	0.192	0.192	0.19	0.19													
191		W-MC01-210	橫向收口鋁板	EC-DG-D334232-ZD1 (閃粉古銅)	1		1	0.294	0.054	0.054	0.06	0.06													
192		W-MC01-302	橫向收口鋁板	EC-DG-D334232-ZD1 (閃粉古銅)	1		1	0.294	0.054	0.054	0.06	0.06													
							合計:	1330	1180.992	217.895	221.419														

10

				T2企/橫向室內收口鋁折件/樓層/數量派位																						
序號	座數	位置	圖號	5F	6F	7F	8F	9F	10F	11F	12F	15F	16F	17F	18F	19F	20F	21F	22F	23F	25F	26F	合計			
1	T2	J853-SD-CW-4201左	H-MA01-21												1	1	1	1	1				6			
2	T2	J853-SD-CW-4201左	H-MA01-22																				1	1		
3	T2	J853-SD-CW-4201左	H-MA01-23																			1		1		
4	T2	J853-SD-CW-4201左	H-MA01-24																		1			1		
5	T2	J853-SD-CW-4201右	H-MA01-21		2	2	2	2	2	2	2	2	2	2	2	2	2	2	2	2				28		
6	T2	J853-SD-CW-4201右	H-MA01-23	2									2											4		
7	T2	J853-SD-CW-4201右	H-MA01-25																		2			2		
8	T2	J853-SD-CW-4202左	H-MA01-21		2	2	2	2	2	2	2	2	2											16		
9	T2	J853-SD-CW-4202左	H-MA01-23	2									2											4		
10	T2	J853-SD-CW-4202右	H-MA01-21											1	1	1	1	1	1					6		
11	T2	J853-SD-CW-4202右	H-MA01-24																		1			1		
12	T2	J853-SD-CW-4202右	H-MA01-23																			2		2		
13	T2	J853-SD-CW-4202右	H-MA01-22																			2		2		
14	T2	J853-SD-CW-4203右	H-MA01-21											1	1	1	1	1	1					6		
15	T2	J853-SD-CW-4203右	H-MA01-25																		1			1		
16	T2	J853-SD-CW-4204	H-MA01-21		1	1	1	1	1	1	1	1	1	1	1	1	1	1	1					14		
17	T2	J853-SD-CW-4204	H-MA01-23	1									1									1		3		
18	T2	J853-SD-CW-4204	H-MA01-24																		1			1		
19	T2	J853-SD-CW-4204	H-MA01-22																			1		1		
20	T2	J853-SD-CW-4205左	H-MA01-21		1	1	1	1	1	1	1	1	1	1	1	1	1	1	1					14		
21	T2	J853-SD-CW-4205左	H-MA01-23	1									1									1		3		
22	T2	J853-SD-CW-4205左	H-MA01-24																		1			1		
23	T2	J853-SD-CW-4205左	H-MA01-22																			1		1		
24	T2	J853-SD-CW-4206右	H-MA01-22																			1		1		
25	T2	J853-SD-CW-4203左	H-MB01-21		1	1	1	1	1	1	1	1												8		
26	T2	J853-SD-CW-4203左	H-MB01-23	1									1											2		
27	T2	J853-SD-CW-4203右	H-MB01-21											1	1	1	1	1	1					6		
28	T2	J853-SD-CW-4203右	H-MB01-25																		1			1		
29	T2	J853-SD-CW-4204A	H-MB01-21		2	2	2	2	2	2	2	2	2	2	2	2	2	2	2					28		
30	T2	J853-SD-CW-4204A	H-MB01-23	2									2									2		6		
31	T2	J853-SD-CW-4204A	H-MB01-24																		2			2		
32	T2	J853-SD-CW-4204A	H-MB01-22																			2		2		
33	T2	J853-SD-CW-4206左	H-MB01-22																			1		1		
34	T2	J853-SD-CW-4202左	H-MC01-21		2	2	2	2	2	2	2	2												16		
35	T2	J853-SD-CW-4202左	H-MC01-23	2									2											4		
36	T2	J853-SD-CW-4204	H-MC01-21		2	2	2	2	2	2	2	2	2	2	2	2	2	2	2					28		
37	T2	J853-SD-CW-4204	H-MC01-23	2									2									2		6		
38	T2	J853-SD-CW-4204	H-MC01-24																		2			2		
39	T2	J853-SD-CW-4204	H-MC01-22																				2	2		
40	T2	J853-SD-CW-4204A	H-MC01-21		4	4	4	4	4	4	4	4	4	4	4	4	4	4	4					56		
41	T2	J853-SD-CW-4204A	H-MC01-23	4									4									4		12		
42	T2	J853-SD-CW-4204A	H-MC01-24																		4			4		
43	T2	J853-SD-CW-4204A	H-MC01-22																			4		4		
44	T2	J853-SD-CW-4205左	H-MC01-21		2	2	2	2	2	2	2	2	2	2	2	2	2	2	2					28		
45	T2	J853-SD-CW-4205左	H-MC01-23	2									2									2		6		
46	T2	J853-SD-CW-4205左	H-MC01-24																		2			2		
47	T2	J853-SD-CW-4205左	H-MC01-22																				2	2		
48	T2	J853-SD-CW-4205右	H-MC01-21		2	2	2	2	2	2	2	2												16		
49	T2	J853-SD-CW-4205右	H-MC01-23										2											2		
50	T2	J853-SD-CW-4206右	H-MC01-22																				2	2		
51	T2	J853-SD-CW-4201左	H-MD01-21		1	1	1	1	1	1	1	1	1	1	1	1	1	1	1					14		
52	T2	J853-SD-CW-4201左	H-MD01-22																				1	1		
53	T2	J853-SD-CW-4201左	H-MD01-23	1									1									1		3		
54	T2	J853-SD-CW-4201左	H-MD01-24																		1			1		
55	T2	J853-SD-CW-4206左	H-MF01-22																				1	1		
56	T2	J853-SD-CW-4201左	W-MA01-201	1	1	1	1	1	1	1	1	1	1											10		
57	T2	J853-SD-CW-4201左	W-MA01-202											1	1	1	1	1	1	1	1	1		8		
58	T2	J853-SD-CW-4201右	W-MA01-203	1	1	1	1	1	1	1	1	1	1	1	1	1	1	1	1					16		
59	T2	J853-SD-CW-4202左	W-MA01-204	1	1	1	1	1	1	1	1	1	1											10		
60	T2	J853-SD-CW-4202左	W-MA01-205	1	1	1	1	1	1	1	1	1	1											10		



				T2企/橫向室內收口鋁折件/樓層/數量派位																							
序號	座數	位置	圖號	5F	6F	7F	8F	9F	10F	11F	12F	15F	16F	17F	18F	19F	20F	21F	22F	23F	25F	26F	合計				
61	T2	J853-SD-CW-4202右	W-MA01-206												1	1	1	1	1	1			7				
62	T2	J853-SD-CW-4202右	W-MA01-207																			1		1			
63	T2	J853-SD-CW-4202右	W-MA01-208																			1		1			
64	T2	J853-SD-CW-4204	W-MA01-212	1	1	1	1	1	1	1	1	1	1	1	1	1	1	1	1	1	1	1	1	18			
65	T2	J853-SD-CW-4204	W-MA01-213	1	1	1	1	1	1	1	1	1	1	1	1	1	1	1	1	1	1	1	1	18			
66	T2	J853-SD-CW-4204A	W-MA01-215	2	2	2	2	2	2	2	2	2	2	2	2	2	2	2	2	2	2	2	2	36			
67	T2	J853-SD-CW-4205左	W-MA01-216	1	1	1	1	1	1	1	1	1	1	1	1	1	1	1	1	1	1	1	1	18			
68	T2	J853-SD-CW-4205左	W-MA01-212	1	1	1	1	1	1	1	1	1	1	1	1	1	1	1	1	1	1	1	1	18			
69	T2	J853-SD-CW-4206左	W-MA01-223																			1		1			
70	T2	J853-SD-CW-4206左	W-MA01-224																			1		1			
71	T2	J853-SD-CW-4201左	W-MB01-202																				1	1			
72	T2	J853-SD-CW-4202右	W-MB01-207																				1	1			
73	T2	J853-SD-CW-4202右	W-MB01-208																				1	1			
74	T2	J853-SD-CW-4204	W-MB01-212																				1	1			
75	T2	J853-SD-CW-4204	W-MB01-213																				1	1			
76	T2	J853-SD-CW-4204A	W-MB01-215																				2	2			
77	T2	J853-SD-CW-4205左	W-MB01-216																				1	1			
78	T2	J853-SD-CW-4205左	W-MB01-212																				1	1			
79	T2	J853-SD-CW-4206左	W-MB01-221																				1	1			
80	T2	J853-SD-CW-4206左	W-MB01-222																				1	1			
81	T2	J853-SD-CW-4206右	W-MB01-225																				1	1			
82	T2	J853-SD-CW-4206右	W-MB01-226																				1	1			
83	T2	J853-SD-CW-4201右	W-MC01-203																			1		1			
84	T2	J853-SD-CW-4204A	W-MAFK01L-214	1	1	1	1	1	1	1	1	1	1	1	1	1	1	1	1	1	1	1	1	18			
85	T2	J853-SD-CW-4205右	W-MAFK01L-217		1	1	1	1	1	1	1	1	1											9			
86	T2	J853-SD-CW-4204A	W-MAFK01R-214	1	1	1	1	1	1	1	1	1	1	1	1	1	1	1	1	1	1	1	1	18			
87	T2	J853-SD-CW-4205右	W-MAFK01R-218		1	1	1	1	1	1	1	1	1											9			
88	T2	J853-SD-CW-4204A	W-MBFK01L-214																				1	1			
89	T2	J853-SD-CW-4204A	W-MBFK01R-214																				1	1			
90	T2	J853-SD-CW-4203左	W-MA01-209	1	1	1	1	1	1	1	1	1	1											10			
91	T2	J853-SD-CW-4203右	W-MA01-211												1	1	1	1	1	1				6			
92	T2	J853-SD-CW-4203左	W-MA01-210	1	1	1	1	1	1	1	1	1	1											10			
93	T2	J853-SD-CW-4203右	W-MA01-210												1	1	1	1	1	1				6			
94	T2	J853-SD-CW-4203右	W-MC01-211																			1		1			
95	T2	J853-SD-CW-4203右	W-MC01-210																			1		1			
合計：				34	38	38	38	38	38	38	38	38	38	38	32	32	32	32	32	32	32	29	36	665			

(12)

				T3企/橫向室內收口鋁折件/樓層/數量派位																						
序號	座數	位置	圖號	5F	6F	7F	8F	9F	10F	11F	12F	15F	16F	17F	18F	19F	20F	21F	22F	23F	25F	26F	合計			
1	T3	J853-SD-CW-4301右	H-MA01-21												1	1	1	1	1	1			6			
2	T3	J853-SD-CW-4301右	H-MA01-25																		1		1			
3	T3	J853-SD-CW-4302左	H-MA01-21												1	1	1	1	1	1			6			
4	T3	J853-SD-CW-4302左	H-MA01-22																			1	1			
5	T3	J853-SD-CW-4302左	H-MA01-23																		1		1			
6	T3	J853-SD-CW-4302左	H-MA01-24																	1			1			
7	T3	J853-SD-CW-4302右	H-MA01-21		2	2	2	2	2	2	2	2	2	2	2	2	2	2	2	2			28			
8	T3	J853-SD-CW-4302右	H-MA01-23	2									2										4			
9	T3	J853-SD-CW-4302右	H-MA01-25																		2		2			
10	T3	J853-SD-CW-4303左	H-MA01-21		2	2	2	2	2	2	2	2	2										16			
11	T3	J853-SD-CW-4303左	H-MA01-23	2									2										4			
12	T3	J853-SD-CW-4303右	H-MA01-21												1	1	1	1	1	1			6			
13	T3	J853-SD-CW-4303右	H-MA01-24																		1		1			
14	T3	J853-SD-CW-4303右	H-MA01-23																		2		2			
15	T3	J853-SD-CW-4303右	H-MA01-22																			2	2			
16	T3	J853-SD-CW-4304	H-MA01-21		1	1	1	1	1	1	1	1	1	1	1	1	1	1	1	1			14			
17	T3	J853-SD-CW-4304	H-MA01-23	1									1								1		3			
18	T3	J853-SD-CW-4304	H-MA01-24																		1		1			
19	T3	J853-SD-CW-4304	H-MA01-22																			1	1			
20	T3	J853-SD-CW-4305左	H-MA01-21		1	1	1	1	1	1	1	1	1	1	1	1	1	1	1	1			14			
21	T3	J853-SD-CW-4305左	H-MA01-23	1									1									1	3			
22	T3	J853-SD-CW-4305左	H-MA01-24																		1		1			
23	T3	J853-SD-CW-4305左	H-MA01-22																			1	1			
24	T3	J853-SD-CW-4306左	H-MA01-22																			1	1			
25	T3	J853-SD-CW-4306右	H-MA01-22																			1	1			
26	T3	J853-SD-CW-4301左	H-MB01-21		1	1	1	1	1	1	1	1	1										8			
27	T3	J853-SD-CW-4301左	H-MB01-23	1									1										2			
28	T3	J853-SD-CW-4301右	H-MB01-21												1	1	1	1	1	1			6			
29	T3	J853-SD-CW-4301右	H-MB01-25																		1		1			
30	T3	J853-SD-CW-4304A	H-MB01-21		2	2	2	2	2	2	2	2	2	2	2	2	2	2	2	2			28			
31	T3	J853-SD-CW-4304A	H-MB01-23	2									2									2	6			
32	T3	J853-SD-CW-4304A	H-MB01-24																		2		2			
33	T3	J853-SD-CW-4304A	H-MB01-22																			2	2			
34	T3	J853-SD-CW-4306左	H-MB01-22																			1	1			
35	T3	J853-SD-CW-4303左	H-MC01-21		2	2	2	2	2	2	2	2	2										16			
36	T3	J853-SD-CW-4303左	H-MC01-23	2									2										4			
37	T3	J853-SD-CW-4304	H-MC01-21		2	2	2	2	2	2	2	2	2	2	2	2	2	2	2	2			28			
38	T3	J853-SD-CW-4304	H-MC01-23	2									2									2	6			
39	T3	J853-SD-CW-4304	H-MC01-24																		2		2			
40	T3	J853-SD-CW-4304	H-MC01-22																			2	2			
41	T3	J853-SD-CW-4304A	H-MC01-21		4	4	4	4	4	4	4	4	4	4	4	4	4	4	4	4			56			
42	T3	J853-SD-CW-4304A	H-MC01-23	4									4									4	12			
43	T3	J853-SD-CW-4304A	H-MC01-24																		4		4			
44	T3	J853-SD-CW-4304A	H-MC01-22																			4	4			
45	T3	J853-SD-CW-4305左	H-MC01-21		2	2	2	2	2	2	2	2	2	2	2	2	2	2	2	2			28			
46	T3	J853-SD-CW-4305左	H-MC01-23	2									2									2	6			
47	T3	J853-SD-CW-4305左	H-MC01-24																		2		2			
48	T3	J853-SD-CW-4305左	H-MC01-22																			2	2			
49	T3	J853-SD-CW-4305右	H-MC01-21		2	2	2	2	2	2	2	2	2										16			
50	T3	J853-SD-CW-4305右	H-MC01-23										2										2			
51	T3	J853-SD-CW-4306右	H-MC01-22																			2	2			
52	T3	J853-SD-CW-4302左	H-ME01-21		1	1	1	1	1	1	1	1	1	1	1	1	1	1	1	1			14			
53	T3	J853-SD-CW-4302左	H-ME01-22																			1	1			
54	T3	J853-SD-CW-4302左	H-ME01-23	1									1									1	3			
55	T3	J853-SD-CW-4302左	H-ME01-24																		1		1			
56	T3	J853-SD-CW-4302左	W-MA01-304	1	1	1	1	1	1	1	1	1	1										10			
57	T3	J853-SD-CW-4302左	W-MA01-305												1	1	1	1	1	1	1	1	8			
58	T3	J853-SD-CW-4302右	W-MA01-306	1	1	1	1	1	1	1	1	1	1	1	1	1	1	1	1	1			16			
59	T3	J853-SD-CW-4303左	W-MA01-307	1																			1			
60	T3	J853-SD-CW-4303左	W-MA01-308	1																			1			

				T3企/橫向室內收口鋁折件/樓層/數量派位																						
序號	座數	位置	圖號	5F	6F	7F	8F	9F	10F	11F	12F	15F	16F	17F	18F	19F	20F	21F	22F	23F	25F	26F	合計			
61	T3	J853-SD-CW-4303左	W-MA01-309		1	1	1	1	1	1	1	1	1										9			
62	T3	J853-SD-CW-4303左	W-MA01-310		1	1	1	1	1	1	1	1	1										9			
63	T3	J853-SD-CW-4303右	W-MA01-311											1	1	1	1	1	1	1			7			
64	T3	J853-SD-CW-4303右	W-MA01-312																			1	1			
65	T3	J853-SD-CW-4303右	W-MA01-313																			1	1			
66	T3	J853-SD-CW-4304	W-MA01-314	1	1	1	1	1	1	1	1	1	1	1	1	1	1	1	1	1	1	1	18			
67	T3	J853-SD-CW-4304	W-MA01-315	1	1	1	1	1	1	1	1	1	1	1	1	1	1	1	1	1	1	1	18			
68	T3	J853-SD-CW-4304A	W-MA01-317	2	2	2	2	2	2	2	2	2	2	2	2	2	2	2	2	2	2	2	36			
69	T3	J853-SD-CW-4305左	W-MA01-318	1	1	1	1	1	1	1	1	1	1	1	1	1	1	1	1	1	1	1	18			
70	T3	J853-SD-CW-4305左	W-MA01-319	1	1	1	1	1	1	1	1	1	1	1	1	1	1	1	1	1	1	1	18			
71	T3	J853-SD-CW-4306左	W-MA01-324																			1	1			
72	T3	J853-SD-CW-4306左	W-MA01-325																			1	1			
73	T3	J853-SD-CW-4302左	W-MB01-305																				1			
74	T3	J853-SD-CW-4303右	W-MB01-312																				1			
75	T3	J853-SD-CW-4303右	W-MB01-313																				1			
76	T3	J853-SD-CW-4304	W-MB01-314																				1			
77	T3	J853-SD-CW-4304	W-MB01-315																				1			
78	T3	J853-SD-CW-4304A	W-MB01-317																				2			
79	T3	J853-SD-CW-4305左	W-MB01-318																				1			
80	T3	J853-SD-CW-4305左	W-MB01-319																				1			
81	T3	J853-SD-CW-4306左	W-MB01-322																				1			
82	T3	J853-SD-CW-4306左	W-MB01-323																				1			
83	T3	J853-SD-CW-4306右	W-MB01-326																				1			
84	T3	J853-SD-CW-4306右	W-MB01-327																				1			
85	T3	J853-SD-CW-4302右	W-MC01-306																			1	1			
86	T3	J853-SD-CW-4304A	W-MAFK01L-316	1	1	1	1	1	1	1	1	1	1	1	1	1	1	1	1	1	1	1	18			
87	T3	J853-SD-CW-4305右	W-MAFK01L-320		1	1	1	1	1	1	1	1	1										9			
88	T3	J853-SD-CW-4304A	W-MAFK01R-316	1	1	1	1	1	1	1	1	1	1	1	1	1	1	1	1	1	1	1	18			
89	T3	J853-SD-CW-4305右	W-MAFK01R-321		1	1	1	1	1	1	1	1	1										9			
90	T3	J853-SD-CW-4304A	W-MBFK01L-316																				1			
91	T3	J853-SD-CW-4304A	W-MBFK01R-316																				1			
92	T3	J853-SD-CW-4301左	W-MA01-301	1	1	1	1	1	1	1	1	1	1										10			
93	T3	J853-SD-CW-4301右	W-MA01-303												1	1	1	1	1	1			6			
94	T3	J853-SD-CW-4301左	W-MA01-302	1	1	1	1	1	1	1	1	1	1										10			
95	T3	J853-SD-CW-4301右	W-MA01-302												1	1	1	1	1	1			6			
96	T3	J853-SD-CW-4301右	W-MC01-303																			1	1			
97	T3	J853-SD-CW-4301右	W-MC01-302																			1	1			
合計：				34	38	38	38	38	38	38	38	38	38	38	32	32	32	32	32	32	32	29	36	665		



美特鋁質有限公司  
MIDI Aluminium Fabricator Ltd.

工程號 J-853 地盤 延坪道住宅

數據表見下頁

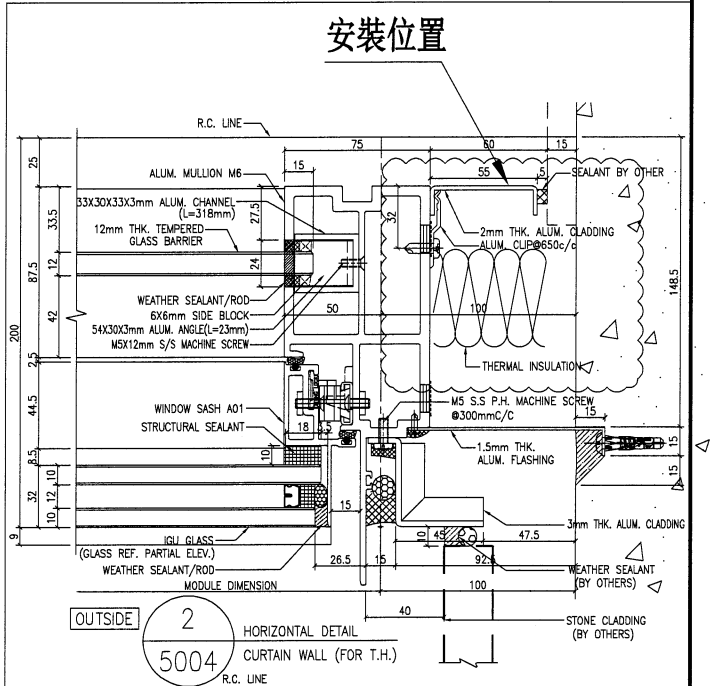
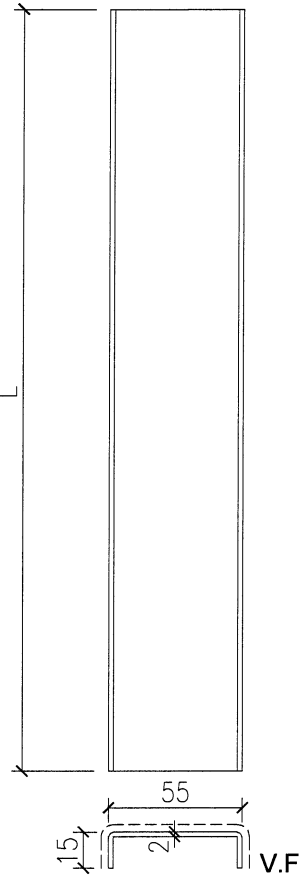

安裝示意图

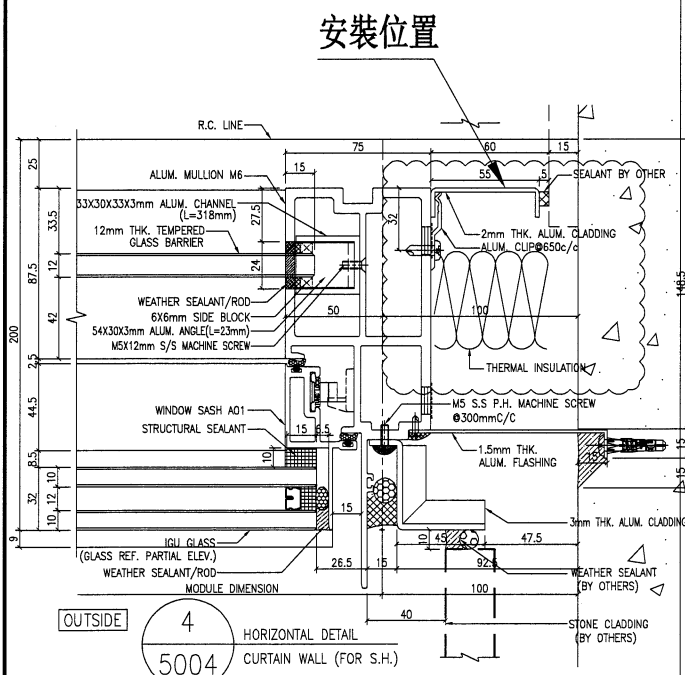

安裝示意图

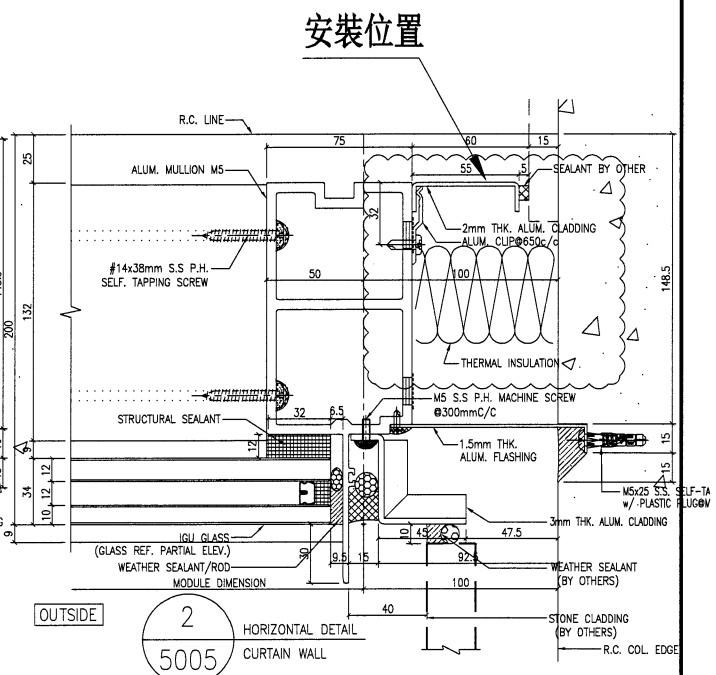

安裝示意图

名稱	企向收口鋁板	制圖	方強	2023. 04. 10	修改		
材料	2mm鋁板	復核	謝永林	2023. 04. 20	日期		
顏色	EC-DG-D334232-ZD1 (閃粉古銅)	批准	Daniel		圖號	H-MA01-21	

序號	物料編號	L	數量	位置	分格尺寸	樓層	樓層數	每層數量	座數
1	H-MA01-21	2215	6	J853-SD-CW-4201左	2192.5	17/F-22/F	6	1	T2
2	H-MA01-22	2272.5	1	J853-SD-CW-4201左	2342.5	26/F	1	1	T2
3	H-MA01-23	2365	1	J853-SD-CW-4201左	2342.5	25/F	1	1	T2
4	H-MA01-24	2465	1	J853-SD-CW-4201左	2442.5	23/F	1	1	T2
5	H-MA01-21	2215	28	J853-SD-CW-4201右	2192.5	6/F-15/F,17/F-22/F	14	2	T2
6	H-MA01-23	2365	4	J853-SD-CW-4201右	2342.5	5/F,16/F	2	2	T2
7	H-MA01-25	2160.5	2	J853-SD-CW-4201右	2242.5	23/F	1	2	T2
8	H-MA01-21	2215	16	J853-SD-CW-4202左	2192.5	6/F-15/F	8	2	T2
9	H-MA01-23	2365	4	J853-SD-CW-4202左	2342.5	5/F,16/F	2	2	T2
10	H-MA01-21	2215	6	J853-SD-CW-4202右	2192.5	17/F-22/F	6	1	T2
11	H-MA01-24	2465	1	J853-SD-CW-4202右	2442.5	23/F	1	1	T2
12	H-MA01-23	2365	2	J853-SD-CW-4202右	2342.5	25/F	1	2	T2
13	H-MA01-22	2272.5	2	J853-SD-CW-4202右	2342.5	26/F	1	2	T2
14	H-MA01-21	2215	6	J853-SD-CW-4203右	2192.5	17/F-22/F	6	1	T2
15	H-MA01-25	2160.5	1	J853-SD-CW-4203右	2242.5	23/F	1	1	T2
16	H-MA01-21	2215	14	J853-SD-CW-4204	2192.5	6/F-15/F,17/F-22/F	14	1	T2
17	H-MA01-23	2365	3	J853-SD-CW-4204	2342.5	5/F,16/F,25/F	3	1	T2
18	H-MA01-24	2465	1	J853-SD-CW-4204	2442.5	23/F	1	1	T2
19	H-MA01-22	2272.5	1	J853-SD-CW-4204	2342.5	26/F	1	1	T2
20	H-MA01-21	2215	14	J853-SD-CW-4205左	2192.5	6/F-15/F,17/F-22/F	14	1	T2
21	H-MA01-23	2365	3	J853-SD-CW-4205左	2342.5	5/F,16/F,25/F	3	1	T2
22	H-MA01-24	2465	1	J853-SD-CW-4205左	2442.5	23/F	1	1	T2
23	H-MA01-22	2272.5	1	J853-SD-CW-4205左	2342.5	26/F	1	1	T2
24	H-MA01-22	2272.5	1	J853-SD-CW-4206右	2342.5	26/F	1	1	T2
25	H-MA01-21	2215	6	J853-SD-CW-4301右	2192.5	17/F-22/F	6	1	T3
26	H-MA01-25	2160.5	1	J853-SD-CW-4301右	2242.5	23/F	1	1	T3
27	H-MA01-21	2215	6	J853-SD-CW-4302左	2192.5	17/F-22/F	6	1	T3
28	H-MA01-22	2272.5	1	J853-SD-CW-4302左	2342.5	26/F	1	1	T3
29	H-MA01-23	2365	1	J853-SD-CW-4302左	2342.5	25/F	1	1	T3
30	H-MA01-24	2465	1	J853-SD-CW-4302左	2442.5	23/F	1	1	T3
31	H-MA01-21	2215	28	J853-SD-CW-4302右	2192.5	6/F-15/F,17/F-22/F	14	2	T3
32	H-MA01-23	2365	4	J853-SD-CW-4302右	2342.5	5/F,16/F	2	2	T3
33	H-MA01-25	2160.5	2	J853-SD-CW-4302右	2242.5	23/F	1	2	T3
34	H-MA01-21	2215	16	J853-SD-CW-4303左	2192.5	6/F-15/F	8	2	T3
35	H-MA01-23	2365	4	J853-SD-CW-4303左	2342.5	5/F,16/F	2	2	T3
36	H-MA01-21	2215	6	J853-SD-CW-4303右	2192.5	17/F-22/F	6	1	T3
37	H-MA01-24	2465	1	J853-SD-CW-4303右	2442.5	23/F	1	1	T3
38	H-MA01-23	2365	2	J853-SD-CW-4303右	2342.5	25/F	1	2	T3
39	H-MA01-22	2272.5	2	J853-SD-CW-4303右	2342.5	26/F	1	2	T3
40	H-MA01-21	2215	14	J853-SD-CW-4304	2192.5	6/F-15/F,17/F-22/F	14	1	T3
41	H-MA01-23	2365	3	J853-SD-CW-4304	2342.5	5/F,16/F,25/F	3	1	T3
42	H-MA01-24	2465	1	J853-SD-CW-4304	2442.5	23/F	1	1	T3
43	H-MA01-22	2272.5	1	J853-SD-CW-4304	2342.5	26/F	1	1	T3
44	H-MA01-21	2215	14	J853-SD-CW-4305左	2192.5	6/F-15/F,17/F-22/F	14	1	T3
45	H-MA01-23	2365	3	J853-SD-CW-4305左	2342.5	5/F,16/F,25/F	3	1	T3
46	H-MA01-24	2465	1	J853-SD-CW-4305左	2442.5	23/F	1	1	T3
47	H-MA01-22	2272.5	1	J853-SD-CW-4305左	2342.5	26/F	1	1	T3
48	H-MA01-22	2272.5	1	J853-SD-CW-4306左	2342.5	26/F	1	1	T3
49	H-MA01-22	2272.5	1	J853-SD-CW-4306右	2342.5	26/F	1	1	T3
		總數：	241						

名稱	企向收口鋁板(數據表)	制圖	方強	2023. 04. 10	修改			
材料	2mm鋁板	復核	謝永林	2023. 04. 20	日期			
顏色	EC-DG-D334232-ZD1(閃粉古銅)	批准	Daniel		圖號	H-MA01-21(1)		



美特鋁質 有限公司  
MIDI Aluminium Fabricator Ltd.

工程號

J-853

地盤

延坪道住宅

數據表見下頁

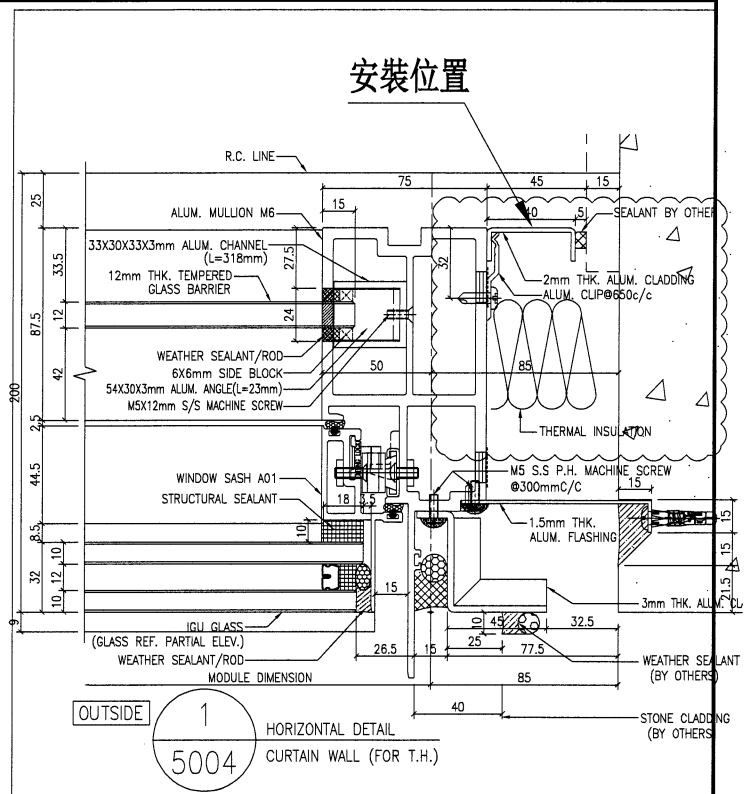
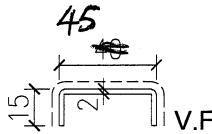
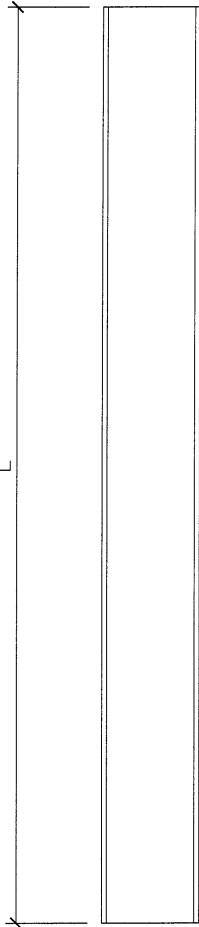

安裝示意图

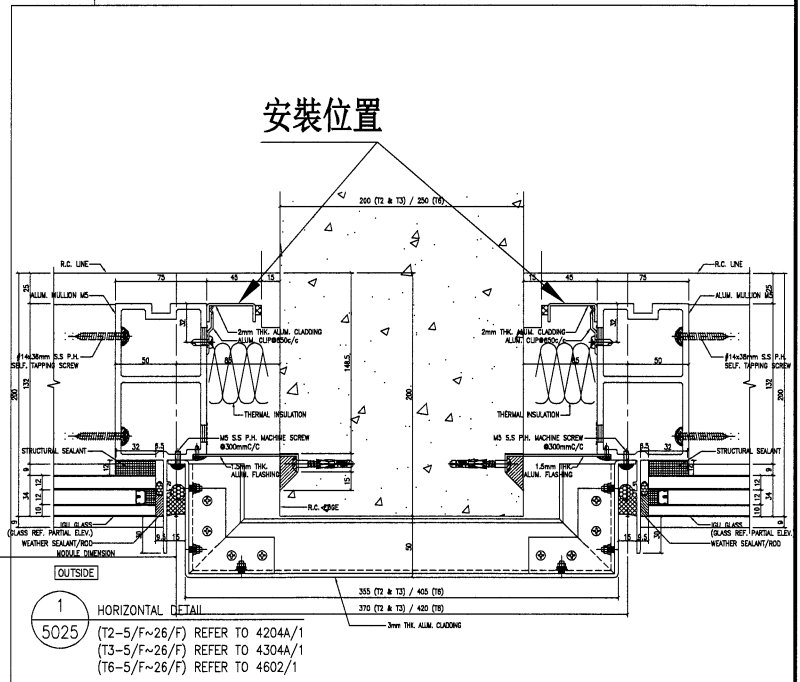

安裝示意图

名稱	企向收口鋁板	制圖	方強	2023.04.10	修改			
材料	2mm鋁板	復核	謝永林	2023.04.20	日期			
顏色	EC-DG-D334232-ZD1(閃粉古銅)	批准	Daniel		圖號	H-MB01-21		

 美特鋁質有限公司 MIDI Aluminium Fabricator Ltd.				拆圖見上頁					
工程號	J-853	地盤	延坪道住宅						
序號	物料編號	L	數量	位置	分格尺寸	樓層	樓層數	每層數量	座數
1	H-MB01-21	2215	8	J853-SD-CW-4203左	2192.5	6/F-15/F	8	1	T2
2	H-MB01-23	2365	2	J853-SD-CW-4203左	2342.5	5/F,16/F	2	1	T2
3	H-MB01-21	2215	6	J853-SD-CW-4203右	2192.5	17/F-22/F	6	1	T2
4	H-MB01-25	2160.5	1	J853-SD-CW-4203右	2242.5	23/F	1	1	T2
5	H-MB01-21	2215	28	J853-SD-CW-4204A	2192.5	6/F-15/F,17/F-22/F	14	2	T2
6	H-MB01-23	2365	6	J853-SD-CW-4204A	2342.5	5/F,16/F,25/F	3	2	T2
7	H-MB01-24	2465	2	J853-SD-CW-4204A	2442.5	23/F	1	2	T2
8	H-MB01-22	2272.5	2	J853-SD-CW-4204A	2342.5	26/F	1	2	T2
9	H-MB01-22	2272.5	1	J853-SD-CW-4206左	2342.5	26/F	1	1	T2
10	H-MB01-21	2215	8	J853-SD-CW-4301左	2192.5	6/F-15/F	8	1	T3
11	H-MB01-23	2365	2	J853-SD-CW-4301左	2342.5	5/F,16/F	2	1	T3
12	H-MB01-21	2215	6	J853-SD-CW-4301右	2192.5	17/F-22/F	6	1	T3
13	H-MB01-25	2160.5	1	J853-SD-CW-4301右	2242.5	23/F	1	1	T3
14	H-MB01-21	2215	28	J853-SD-CW-4304A	2192.5	6/F-15/F,17/F-22/F	14	2	T3
15	H-MB01-23	2365	6	J853-SD-CW-4304A	2342.5	5/F,16/F,25/F	3	2	T3
16	H-MB01-24	2465	2	J853-SD-CW-4304A	2442.5	23/F	1	2	T3
17	H-MB01-22	2272.5	2	J853-SD-CW-4304A	2342.5	26/F	1	2	T3
18	H-MB01-22	2272.5	1	J853-SD-CW-4306左	2342.5	26/F	1	1	T3
		總數：	112						
名稱	企向收口鋁板(數據表)			制圖	方強	2023. 04. 10	修改		
材料	2mm鋁板			復核	謝永林	2023. 04. 20	日期		
顏色	EC-DG-D334232-ZD1(閃粉古銅)			批准	Daniel		圖號	H-MB01-21(1)	



 <b>美特鋁質有限公司</b> MIDI Aluminium Fabricator Ltd.				拆圖見上頁					
工程號	J-853	地盤	延坪道住宅						
序號	物料編號	L	數量	位置	分格尺寸	樓層	樓層數	每層數量	座數
1	H-MC01-21	2215	16	J853-SD-CW-4202左	2192.5	6/F-15/F	8	2	T2
2	H-MC01-23	2365	4	J853-SD-CW-4202左	2342.5	5/F,16/F	2	2	T2
3	H-MC01-21	2215	28	J853-SD-CW-4204	2192.5	6/F-15/F,17/F-22/F	14	2	T2
4	H-MC01-23	2365	6	J853-SD-CW-4204	2342.5	5/F,16/F,25/F	3	2	T2
5	H-MC01-24	2465	2	J853-SD-CW-4204	2442.5	23/F	1	2	T2
6	H-MC01-22	2272.5	2	J853-SD-CW-4204	2342.5	26/F	1	2	T2
7	H-MC01-21	2215	56	J853-SD-CW-4204A	2192.5	6/F-15/F,17/F-22/F	14	4	T2
8	H-MC01-23	2365	12	J853-SD-CW-4204A	2342.5	5/F,16/F,25/F	3	4	T2
9	H-MC01-24	2465	4	J853-SD-CW-4204A	2442.5	23/F	1	4	T2
10	H-MC01-22	2272.5	4	J853-SD-CW-4204A	2342.5	26/F	1	4	T2
11	H-MC01-21	2215	28	J853-SD-CW-4205左	2192.5	6/F-15/F,17/F-22/F	14	2	T2
12	H-MC01-23	2365	6	J853-SD-CW-4205左	2342.5	5/F,16/F,25/F	3	2	T2
13	H-MC01-24	2465	2	J853-SD-CW-4205左	2442.5	23/F	1	2	T2
14	H-MC01-22	2272.5	2	J853-SD-CW-4205左	2342.5	26/F	1	2	T2
15	H-MC01-21	2215	16	J853-SD-CW-4205右	2192.5	6/F-15/F	8	2	T2
16	H-MC01-23	2365	2	J853-SD-CW-4205右	2342.5	16/F	1	2	T2
17	H-MC01-22	2272.5	2	J853-SD-CW-4206右	2342.5	26/F	1	2	T2
18	H-MC01-21	2215	16	J853-SD-CW-4303左	2192.5	6/F-15/F	8	2	T3
19	H-MC01-23	2365	4	J853-SD-CW-4303左	2342.5	5/F,16/F	2	2	T3
20	H-MC01-21	2215	28	J853-SD-CW-4304	2192.5	6/F-15/F,17/F-22/F	14	2	T3
21	H-MC01-23	2365	6	J853-SD-CW-4304	2342.5	5/F,16/F,25/F	3	2	T3
22	H-MC01-24	2465	2	J853-SD-CW-4304	2442.5	23/F	1	2	T3
23	H-MC01-22	2272.5	2	J853-SD-CW-4304	2342.5	26/F	1	2	T3
24	H-MC01-21	2215	56	J853-SD-CW-4304A	2192.5	6/F-15/F,17/F-22/F	14	4	T3
25	H-MC01-23	2365	12	J853-SD-CW-4304A	2342.5	5/F,16/F,25/F	3	4	T3
26	H-MC01-24	2465	4	J853-SD-CW-4304A	2442.5	23/F	1	4	T3
27	H-MC01-22	2272.5	4	J853-SD-CW-4304A	2342.5	26/F	1	4	T3
28	H-MC01-21	2215	28	J853-SD-CW-4305左	2192.5	6/F-15/F,17/F-22/F	14	2	T3
29	H-MC01-23	2365	6	J853-SD-CW-4305左	2342.5	5/F,16/F,25/F	3	2	T3
30	H-MC01-24	2465	2	J853-SD-CW-4305左	2442.5	23/F	1	2	T3
31	H-MC01-22	2272.5	2	J853-SD-CW-4305左	2342.5	26/F	1	2	T3
32	H-MC01-21	2215	16	J853-SD-CW-4305右	2192.5	6/F-15/F	8	2	T3
33	H-MC01-23	2365	2	J853-SD-CW-4305右	2342.5	16/F	1	2	T3
34	H-MC01-22	2272.5	2	J853-SD-CW-4306右	2342.5	26/F	1	2	T3
		總數：	384						
名稱	企向收口鋁板(數據表)			制圖	方強	2023. 04. 10	修改		
材料	2mm鋁板			復核	謝永林	2023. 04. 20	日期		
顏色	EC-DG-D334232-ZD1(閃粉古銅)			批准	Daniel		圖號	H-MC01-21(1)	



美特鋁質有限公司  
MIDI Aluminium Fabricator Ltd.

工程號 J-853 地盤 延坪道住宅

序號	物料編號	L	數量	位置	分格尺寸	樓層	樓層數	每層數量	座數	
1	H-MD01-21	2215	14	J853-SD-CW-4201左	2192.5	6/F-15/F,17/F-22/F	14	1	T2	
2	H-MD01-22	2272.5	1	J853-SD-CW-4201左	2342.5	26/F	1	1	T2	
3	H-MD01-23	2365	3	J853-SD-CW-4201左	2342.5	5/F,16/F,25/F	3	1	T2	
4	H-MD01-24	2465	1	J853-SD-CW-4201左	2442.5	23/F	1	1	T2	
		總數：	19							

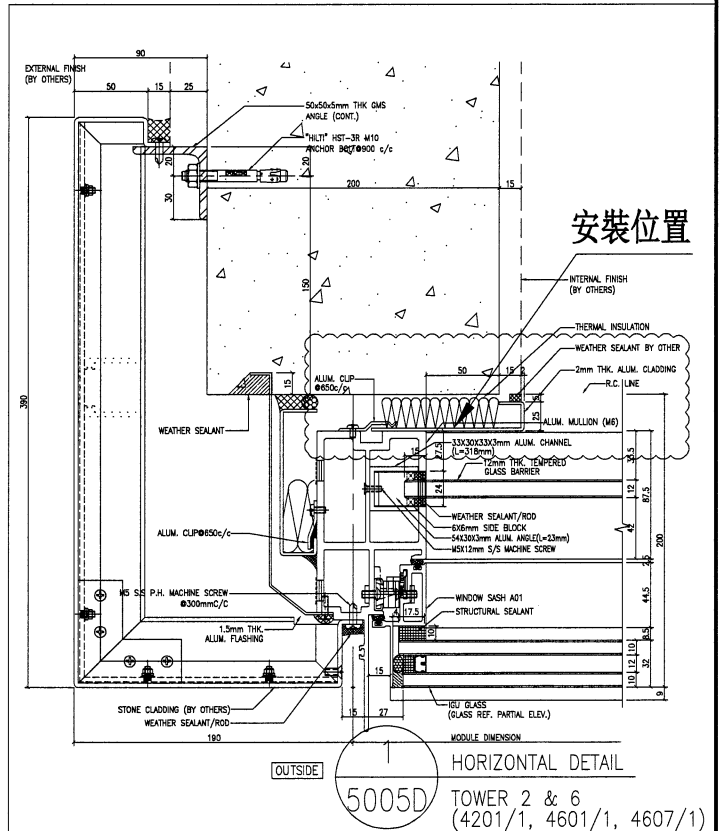
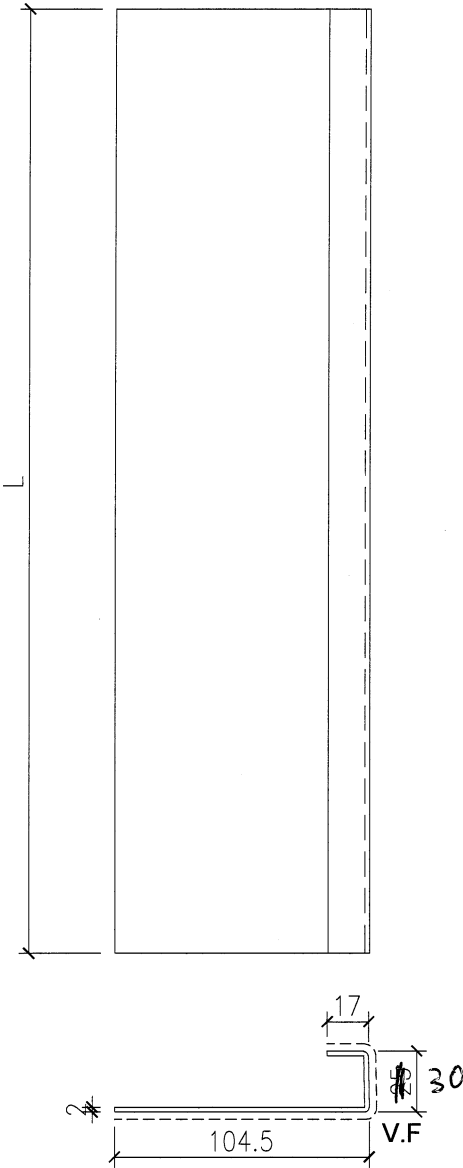

安裝示意图

名稱	企向收口鋁板	制圖	方強	2023. 04. 10	修改			
材料	2mm鋁板	復核	謝永林	2023. 04. 20	日期			
顏色	EC-DG-D334232-ZD1 (閃粉古銅)	批准	Daniel		圖號	H-MD01-21		



**美特鋁質有限公司**  
MIDI Aluminium Fabricator Ltd.

工程號 J-853 地盤 延坪道住宅

序號	物料編號	L	數量	位置	分格尺寸	樓層	樓層數	每層數量	座數
1	H-MF01-22	2272.5	1	J853-SD-CW-4206左	2342.5	26/F	1	1	T2
			總數:	1					

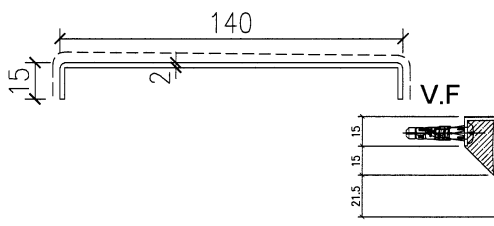
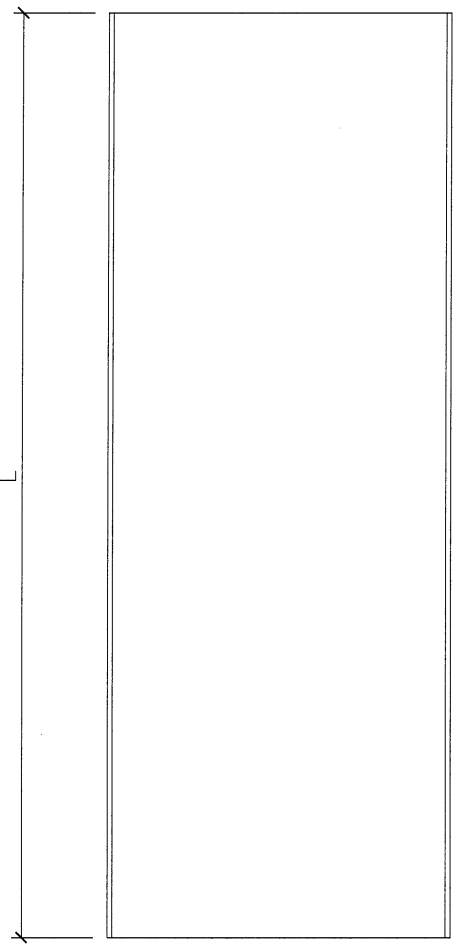

**J853-SD-CW-4206左185寬節點**

安裝位置

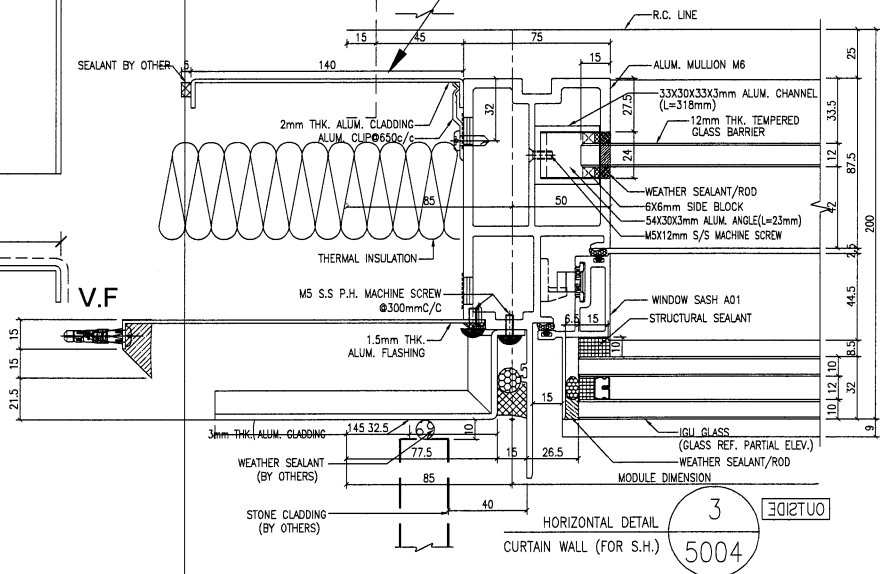

安裝示意图

名稱	企向收口鋁板	制圖	方強	2023.04.10	修改			
材料	2mm鋁板	復核	謝永林	2023.04.20	日期			
顏色	EC-DG-D334232-ZD1 (閃粉古銅)	批准	Daniel		圖號	H-MF01-22		





美特鋁質有限公司

MIDI Aluminium Fabricator Ltd.

拆圖見上頁

工程號	J-853	地盤	延坪道住宅
-----	-------	----	-------

序號	物料編號	L	數量	位置	分格尺寸	樓層	樓層數	每層數量	座數
1	W-MA01-201	1168	10	J853-SD-CW-4201左	1200	5/F-16/F	10	1	T2
2	W-MA01-202	2368	8	J853-SD-CW-4201左	2400	17/F-25/F	8	1	T2
3	W-MA01-203	1470	16	J853-SD-CW-4201右	1300	5/F-22/F	16	1	T2
4	W-MA01-204	1818	10	J853-SD-CW-4202左	1787.5	5/F-16/F	10	1	T2
5	W-MA01-205	1343	10	J853-SD-CW-4202左	1312.5	5/F-16/F	10	1	T2
6	W-MA01-206	2070	7	J853-SD-CW-4202右	1900	17/F-23/F	7	1	T2
7	W-MA01-207	2435	1	J853-SD-CW-4202右	2350	25/F	1	1	T2
8	W-MA01-208	835	1	J853-SD-CW-4202右	750	25/F	1	1	T2
9	W-MA01-212	1443	18	J853-SD-CW-4204	1412.5	5/F-25/F	18	1	T2
10	W-MA01-213	1493	18	J853-SD-CW-4204	1462.5	5/F-25/F	18	1	T2
11	W-MA01-215	2218	36	J853-SD-CW-4204A	2202.5	5/F-25/F	18	2	T2
12	W-MA01-216	1643	18	J853-SD-CW-4205左	1612.5	5/F-25/F	18	1	T2
13	W-MA01-212	1443	18	J853-SD-CW-4205左	1412.5	5/F-25/F	18	1	T2
14	W-MA01-223	2390	1	J853-SD-CW-4206左	2205	25/F	1	1	T2
15	W-MA01-224	685	1	J853-SD-CW-4206左	600	25/F	1	1	T2
16	W-MA01-304	1168	10	J853-SD-CW-4302左	1225	5/F-16/F	10	1	T3
17	W-MA01-305	2368	8	J853-SD-CW-4302左	2425	17/F-25/F	8	1	T3
18	W-MA01-306	1470	16	J853-SD-CW-4302右	1300	5/F-22/F	16	1	T3
19	W-MA01-307	1718	1	J853-SD-CW-4303左	1687.5	5/F	1	1	T3
20	W-MA01-308	1468	1	J853-SD-CW-4303左	1437.5	5/F	1	1	T3
21	W-MA01-309	1843	9	J853-SD-CW-4303左	1812.5	6/F-16/F	9	1	T3
22	W-MA01-310	1343	9	J853-SD-CW-4303左	1312.5	6/F-16/F	9	1	T3
23	W-MA01-311	2095	7	J853-SD-CW-4303右	1925	17/F-23/F	7	1	T3
24	W-MA01-312	2460	1	J853-SD-CW-4303右	2375	25/F	1	1	T3
25	W-MA01-313	835	1	J853-SD-CW-4303右	750	25/F	1	1	T3
26	W-MA01-314	1443	18	J853-SD-CW-4304	1412.5	5/F-25/F	18	1	T3
27	W-MA01-315	1643	18	J853-SD-CW-4304	1612.5	5/F-25/F	18	1	T3
28	W-MA01-317	2218	36	J853-SD-CW-4304A	2202.5	5/F-25/F	18	2	T3
29	W-MA01-318	1643	18	J853-SD-CW-4305左	1612.5	5/F-25/F	18	1	T3
30	W-MA01-319	1493	18	J853-SD-CW-4305左	1462.5	5/F-25/F	18	1	T3
31	W-MA01-324	2215	1	J853-SD-CW-4306左	2115	25/F	1	1	T3
32	W-MA01-325	685	1	J853-SD-CW-4306左	600	25/F	1	1	T3
		總數：	346						

名稱	橫向收口鋁板(數據表)	制圖	方強	2023. 04. 10	修改			
材料	2mm鋁板	復核	謝永林	2023. 04. 20	日期			
顏色	EC-DG-D334232-ZD1(閃粉古銅)	批准	Daniel		圖號	W-MA01-201(1)		



美特鋁質 有限公司  
MIDI Aluminium Fabricator Ltd.

數據表見下頁

工程號	J-853	地盤	延坪道住宅
-----	-------	----	-------

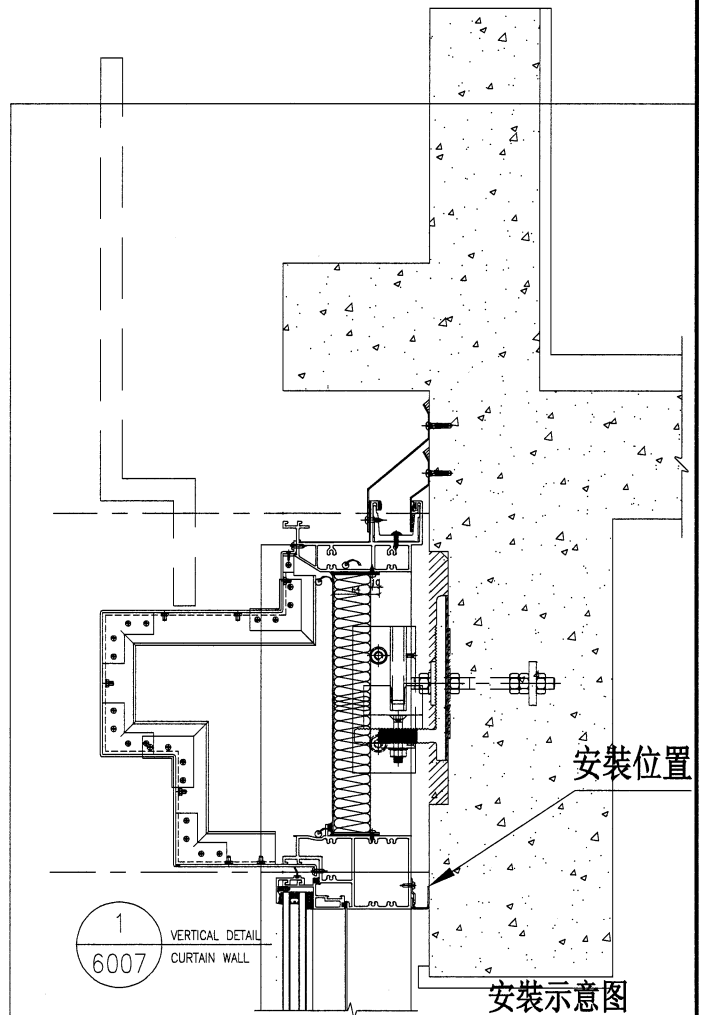
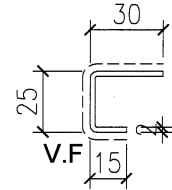
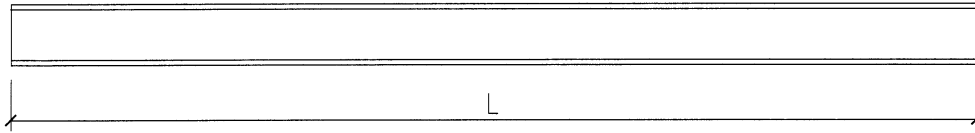

名稱	橫向收口鋁板	制圖	方強	2023. 04. 10	修改			
材料	2mm鋁板	復核	謝永林	2023. 04. 20	日期			
顏色	EC-DG-D334232-ZD1 (閃粉古銅)	批准	Daniel		圖號	W-MB01-202		



美特鋁質 有限公司  
MIDI Aluminium Fabricator Ltd.

拆圖見上頁

工程號	J-853	地盤	延坪道住宅
-----	-------	----	-------

序號	物料編號	L	數量	位置	分格尺寸	樓層	樓層數	每層數量	座數
1	W-MB01-202	2368	1	J853-SD-CW-4201左	2400	26/F	1	1	T2
2	W-MB01-207	2435	1	J853-SD-CW-4202右	2350	26/F	1	1	T2
3	W-MB01-208	835	1	J853-SD-CW-4202右	750	26/F	1	1	T2
4	W-MB01-212	1443	1	J853-SD-CW-4204	1412.5	26/F	1	1	T2
5	W-MB01-213	1493	1	J853-SD-CW-4204	1462.5	26/F	1	1	T2
6	W-MB01-215	2218	2	J853-SD-CW-4204A	2202.5	26/F	1	2	T2
7	W-MB01-216	1643	1	J853-SD-CW-4205左	1612.5	26/F	1	1	T2
8	W-MB01-212	1443	1	J853-SD-CW-4205左	1412.5	26/F	1	1	T2
9	W-MB01-221	2375	1	J853-SD-CW-4206左	2205	26/F	1	1	T2
10	W-MB01-222	670	1	J853-SD-CW-4206左	600	26/F	1	1	T2
11	W-MB01-225	2268	1	J853-SD-CW-4206右	2237.5	26/F	1	1	T2
12	W-MB01-226	1993	1	J853-SD-CW-4206右	1962.5	26/F	1	1	T2
13	W-MB01-305	2368	1	J853-SD-CW-4302左	2425	26/F	1	1	T3
14	W-MB01-312	2460	1	J853-SD-CW-4303右	2375	26/F	1	1	T3
15	W-MB01-313	835	1	J853-SD-CW-4303右	750	26/F	1	1	T3
16	W-MB01-314	1443	1	J853-SD-CW-4304	1412.5	26/F	1	1	T3
17	W-MB01-315	1643	1	J853-SD-CW-4304	1612.5	26/F	1	1	T3
18	W-MB01-317	2218	2	J853-SD-CW-4304A	2202.5	26/F	1	2	T3
19	W-MB01-318	1643	1	J853-SD-CW-4305左	1612.5	26/F	1	1	T3
20	W-MB01-319	1493	1	J853-SD-CW-4305左	1462.5	26/F	1	1	T3
21	W-MB01-322	2200	1	J853-SD-CW-4306左	2115	26/F	1	1	T3
22	W-MB01-323	670	1	J853-SD-CW-4306左	600	26/F	1	1	T3
23	W-MB01-326	2243	1	J853-SD-CW-4306右	2212.5	26/F	1	1	T3
24	W-MB01-327	1993	1	J853-SD-CW-4306右	1962.5	26/F	1	1	T3
		總數：	26						

名稱	橫向收口鋁板(數據表)	制圖	方強	2023. 04. 10	修改			
材料	2mm鋁板	復核	謝永林	2023. 04. 20	日期			
顏色	EC-DG-D334232-ZD1(閃粉古銅)	批准	Daniel		圖號	W-MB01-202(1)		



美特鋁質有限公司  
MIDI Aluminium Fabricator Ltd.

工程號 J-853 地盤 延坪道住宅

序號	物料編號	L	數量	位置	分格尺寸	樓層	樓層數	每層數量	座數
1	W-MC01-203	1470	1	J853-SD-CW-4201右	1300	23/F	1	1	T2
2	W-MC01-306	1470	1	J853-SD-CW-4302右	1300	23/F	1	1	T3
			總數:	2					

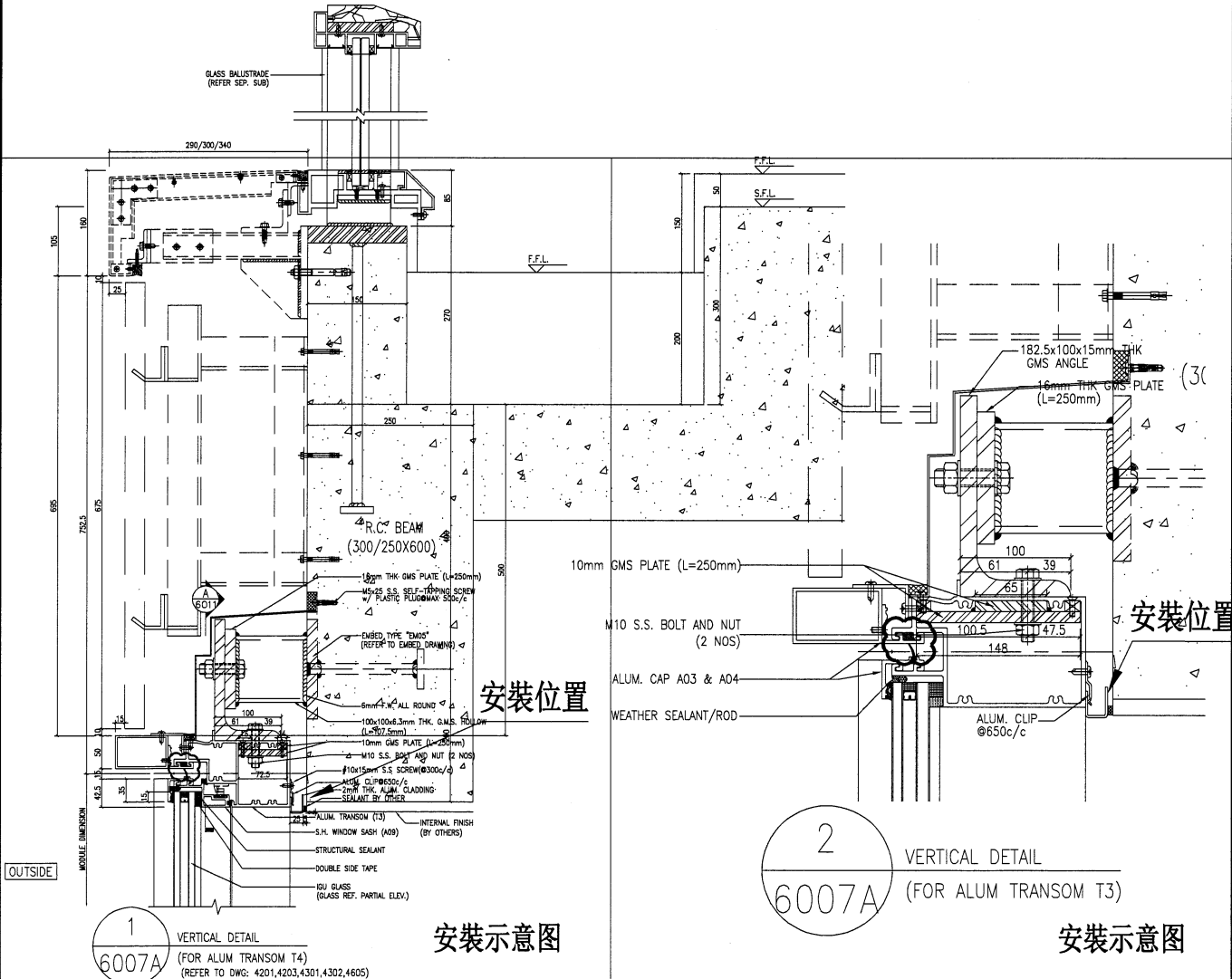
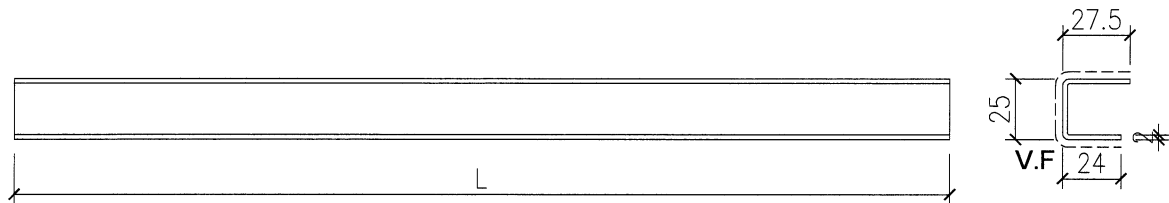

1 VERTICAL DETAIL  
6007A (FOR ALUM TRANSOM T4)  
(REFER TO DWG: 4201,4203,4301,4302,4605)

安裝示意图

2 VERTICAL DETAIL  
6007A (FOR ALUM TRANSOM T3)

安裝示意图

名稱	橫向收口鋁板	制圖	方強	2023. 04. 10	修改			
材料	2mm鋁板	復核	謝永林	2023. 04. 20	日期			
顏色	EC-DG-D334232-ZD1 (閃粉古銅)	批准	Daniel		圖號	W-MC01-203		



美特鋁質有限公司  
MIDI Aluminium Fabricator Ltd.

工程號 J-853 地盤 延坪道住宅

序號	物料編號	L	數量	位置	分格尺寸	樓層	樓層數	每層數量	座數	
1	W-MAFK01L-214	793	18	J853-SD-CW-4204A	717.5	5/F-25/F	18	1	T2	
2	W-MAFK01L-217	1025.5	9	J853-SD-CW-4205右	950	6/F-16/F	9	1	T2	
3	W-MAFK01L-316	793	18	J853-SD-CW-4304A	717.5	5/F-25/F	18	1	T3	
4	W-MAFK01L-320	1000.5	9	J853-SD-CW-4305右	925	6/F-16/F	9	1	T3	
		總數:	54							

端部封口

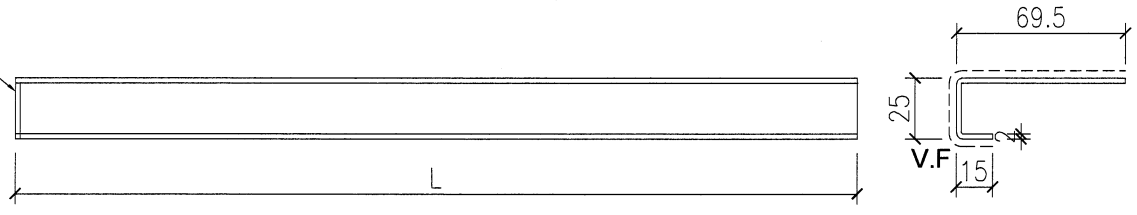

封口示意图

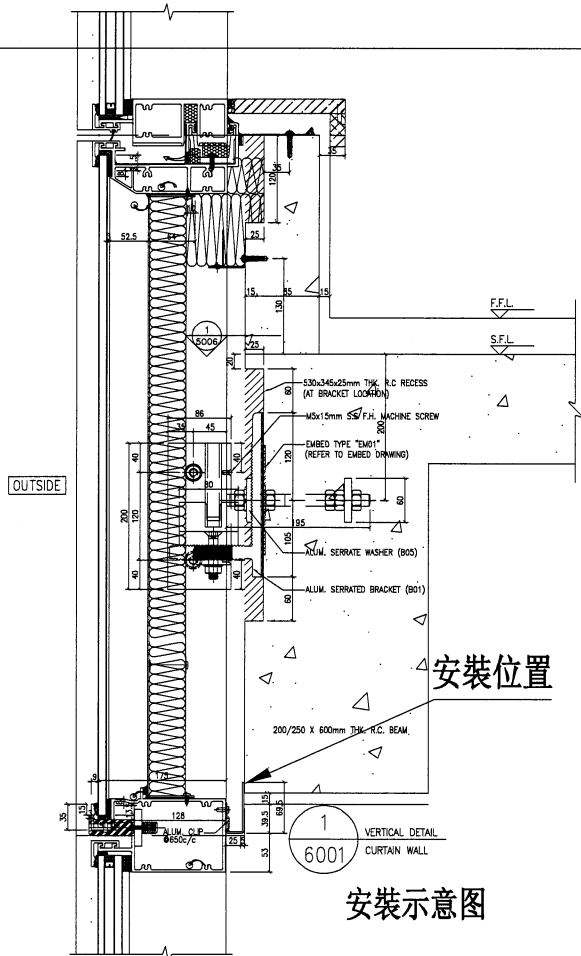
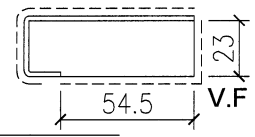

安裝示意图

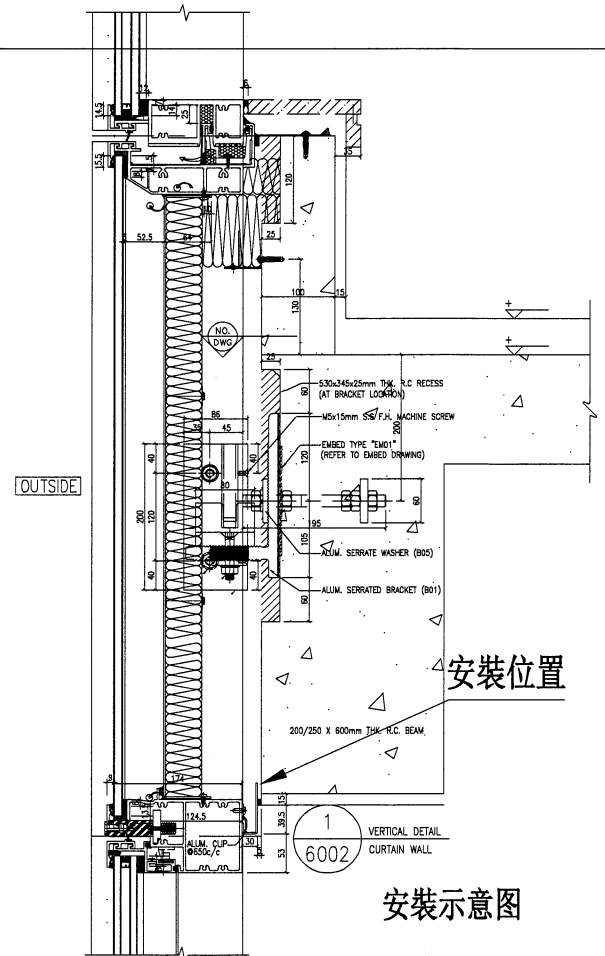

安裝示意图

名稱	橫向收口鋁板	制圖	方強	2023.04.10	修改			
材料	2mm鋁板	復核	謝永林	2023.04.20	日期			
顏色	EC-DG-D334232-ZD1(閃粉古銅)	批准	Daniel		圖號	W-MAFK01L-214		



美特鋁質有限公司  
MIDI Aluminium Fabricator Ltd.

工程號 J-853 地盤 延坪道住宅

序號	物料編號	L	數量	位置	分格尺寸	樓層	樓層數	每層數量	座數	
1	W-MAFK01R-214	793	18	J853-SD-CW-4204A	717.5	5/F-25/F	18	1	T2	
2	W-MAFK01R-218	475.5	9	J853-SD-CW-4205右	400	6/F-16/F	9	1	T2	
3	W-MAFK01R-316	793	18	J853-SD-CW-4304A	717.5	5/F-25/F	18	1	T3	
4	W-MAFK01R-321	475.5	9	J853-SD-CW-4305右	400	6/F-16/F	9	1	T3	
		總數:	54							

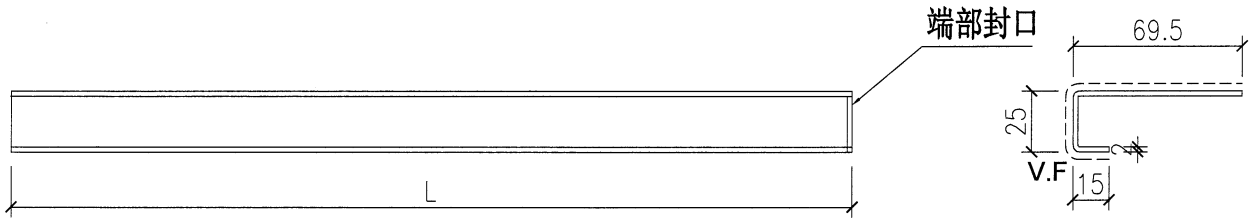

封口示意图

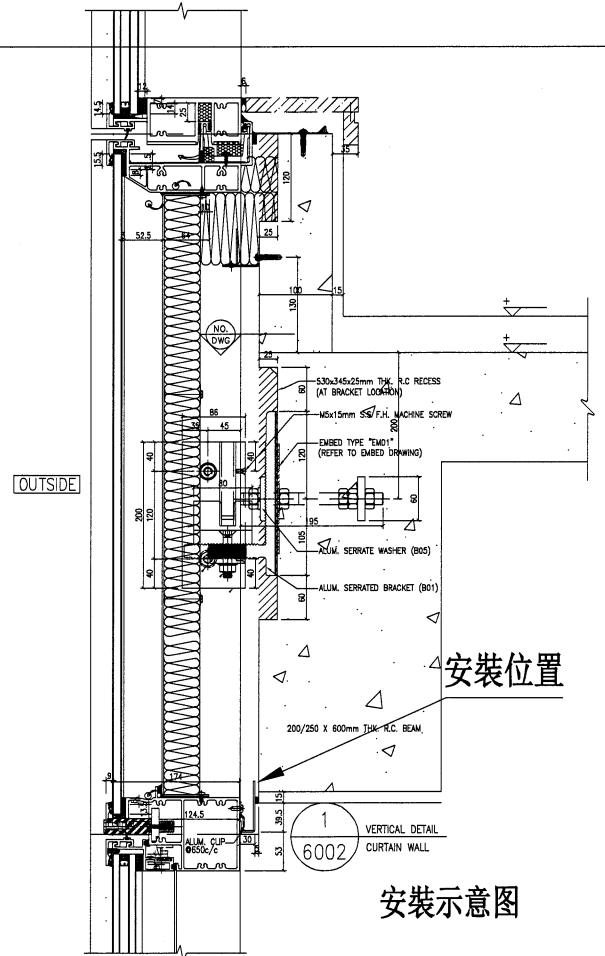
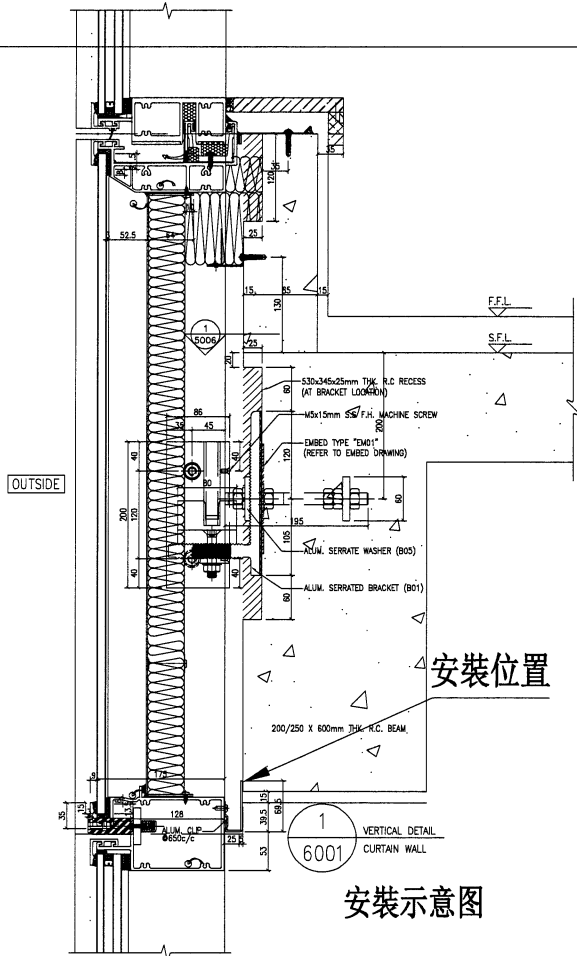
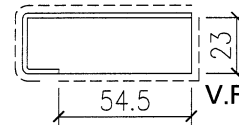

名稱	橫向收口鋁板	制圖	方強	2023. 04. 10	修改			
材料	2mm鋁板	復核	謝永林	2023. 04. 20	日期			
顏色	EC-DG-D334232-ZD1(閃粉古銅)	批準	Daniel		圖號	W-MAFK01R-214		

美特鋁質有限公司  
MIDI Aluminium Fabricator Ltd.

工程號 J-853 地盤 延坪道住宅

序號	物料編號	L	數量	位置	分格尺寸	樓層	樓層數	每層數量	座數
1	W-MBFK01L-214	793	1	J853-SD-CW-4204A	717.5	26/F	1	1	T2
2	W-MBFK01L-316	793	1	J853-SD-CW-4304A	717.5	26/F	1	1	T3
總數：			2						

端部封口

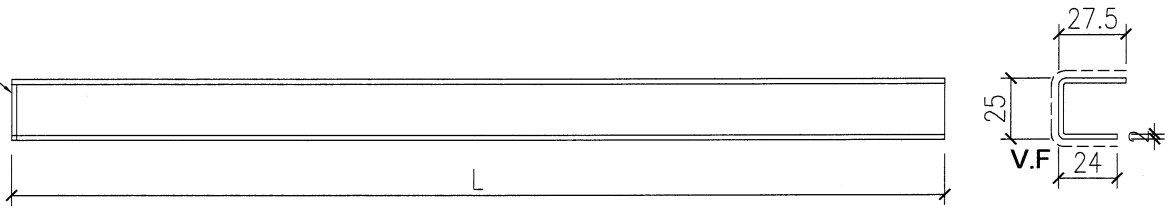

封口示意图

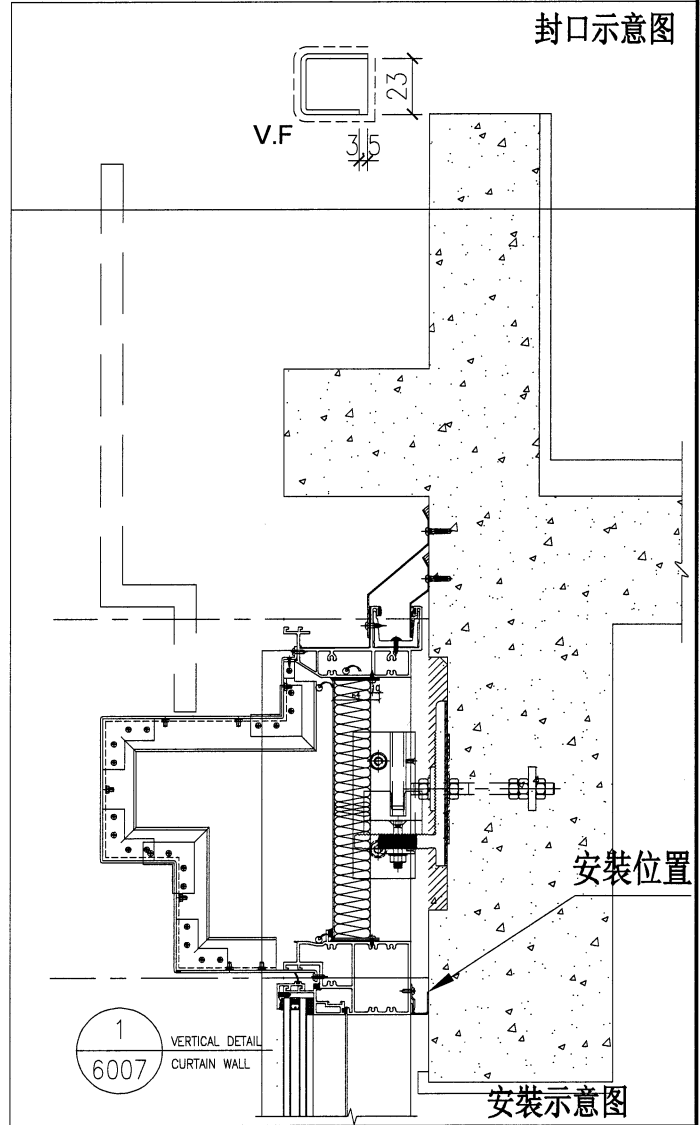

安裝示意图

名稱	橫向收口鋁板	制圖	方強	2023. 04. 10	修改			
材料	2mm鋁板	復核	謝永林	2023. 04. 20	日期			
顏色	EC-DG-D334232-ZD1 (閃粉古銅)	批准	Daniel		圖號	W-MBFK01L-214		

美特鋁質有限公司  
MIDI Aluminium Fabricator Ltd.

工程號 J-853 地盤 延坪道住宅

序號	物料編號	L	數量	位置	分格尺寸	樓層	樓層數	每層數量	座數
1	W-MBFK01R-214	793	1	J853-SD-CW-4204A	717.5	26/F	1	1	T2
2	W-MBFK01R-316	793	1	J853-SD-CW-4304A	717.5	26/F	1	1	T3
總數：			2						

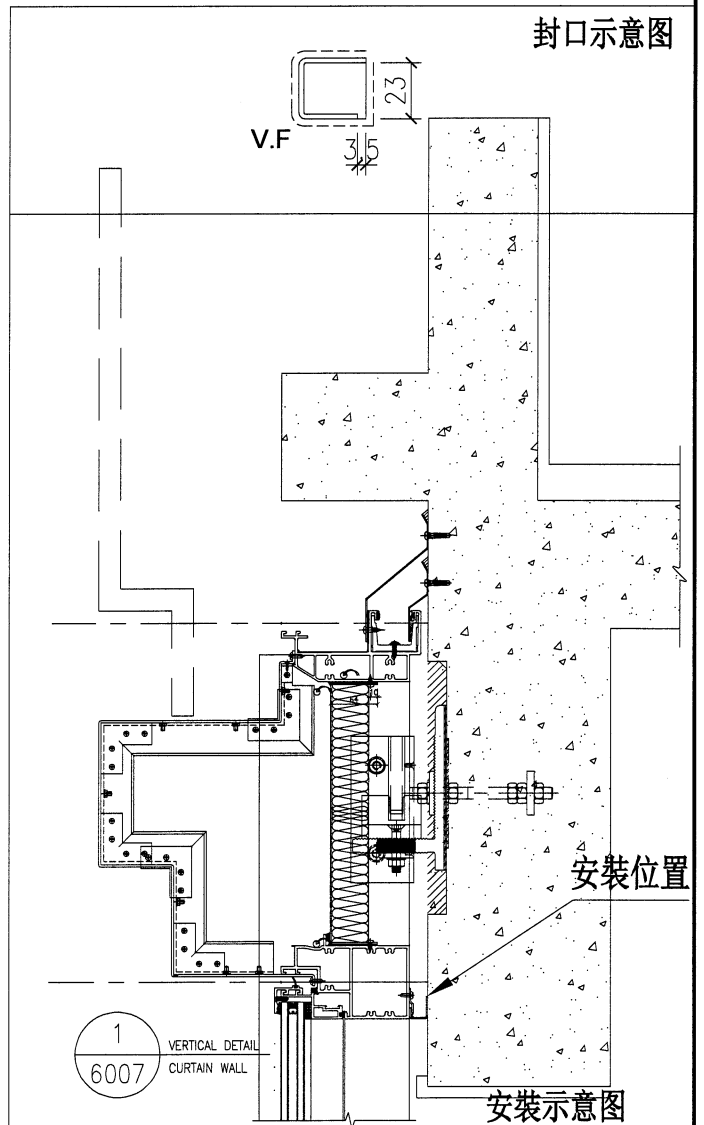
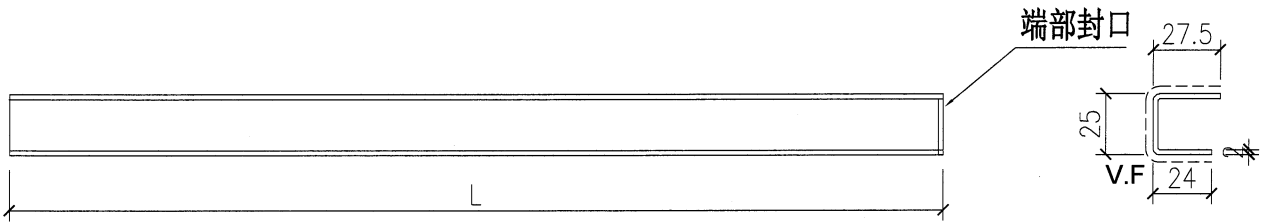

名稱	橫向收口鋁板	制圖	方強	2023. 04. 10	修改			
材料	2mm鋁板	復核	謝永林	2023. 04. 20	日期			
顏色	EC-DG-D334232-ZD1 (閃粉古銅)	批准	Daniel		圖號	W-MBFK01R-214		

序號	物料編號	L	數量	位置	分格尺寸	樓層	樓層數	每層數量	座數
1	W-MA01-209	1310	10	J853-SD-CW-4203左	1400	5/F-16/F	10	1	T2
2	W-MA01-211	2510	6	J853-SD-CW-4203右	2600	17/F-22/F	6	1	T2
3	W-MA01-301	1310	10	J853-SD-CW-4301左	1400	5/F-16/F	10	1	T3
4	W-MA01-303	2510	6	J853-SD-CW-4301右	2600	17/F-22/F	6	1	T3
總數：			32						

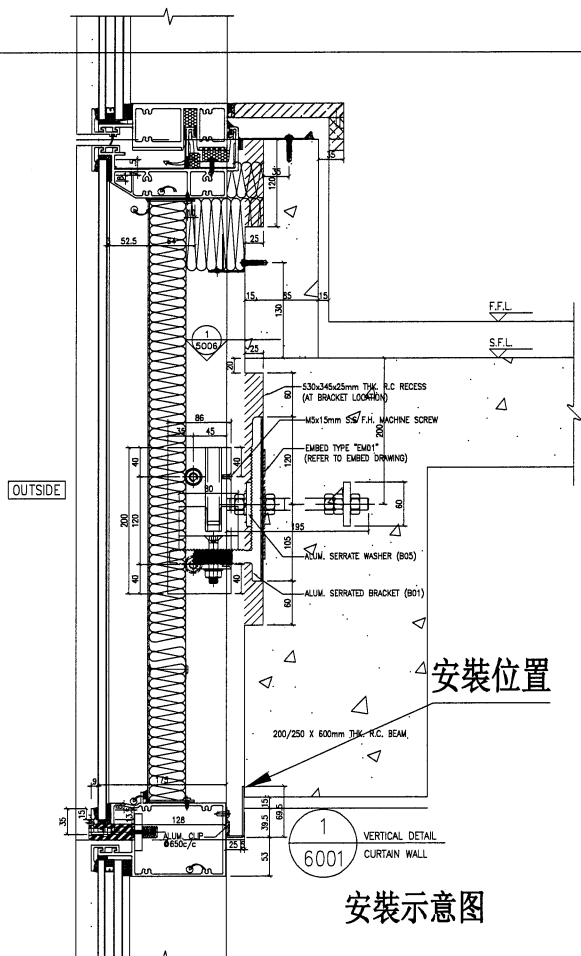
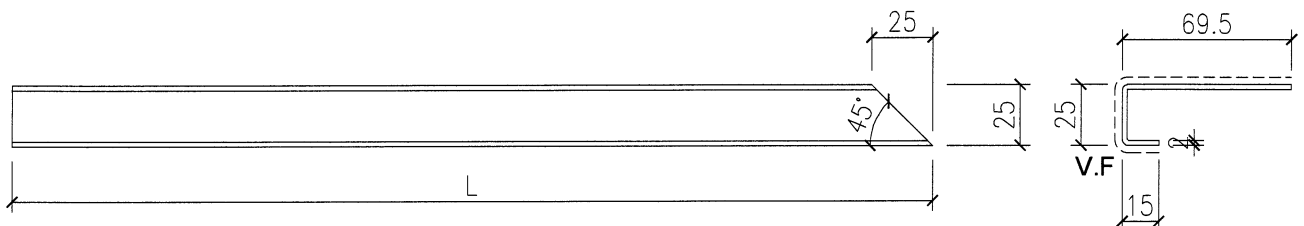

安裝示意图

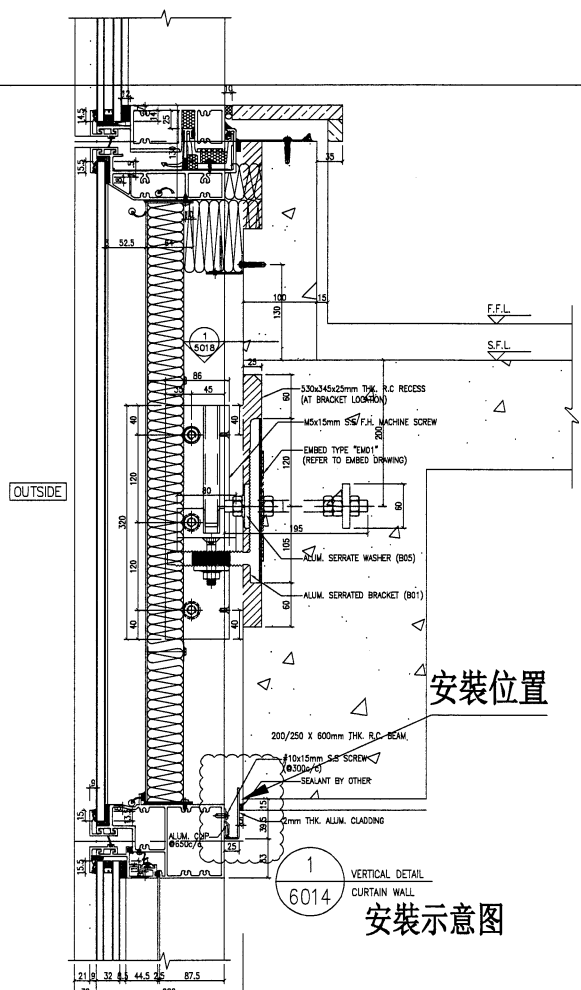

安裝示意图

名稱	轉角橫向收口鋁板	制圖	方強	2023. 04. 10	修改			
材料	2mm鋁板	復核	謝永林	2023. 04. 20	日期			
顏色	EC-DG-D334232-ZD1(閃粉古銅)	批准	Daniel		圖號	W-MA01-209		

工程號	J-853	地盤	延坪道住宅
-----	-------	----	-------

序號	物料編號	L	數量	位置	分格尺寸	樓層	樓層數	每層數量	座數
1	W-MA01-210	710	10	J853-SD-CW-4203左	815	5/F-16/F	10	1	T2
2	W-MA01-210	710	6	J853-SD-CW-4203右	815	17/F-22/F	6	1	T2
3	W-MA01-302	710	10	J853-SD-CW-4301左	815	5/F-16/F	10	1	T3
4	W-MA01-302	710	6	J853-SD-CW-4301右	815	17/F-22/F	6	1	T3
總數：			32						

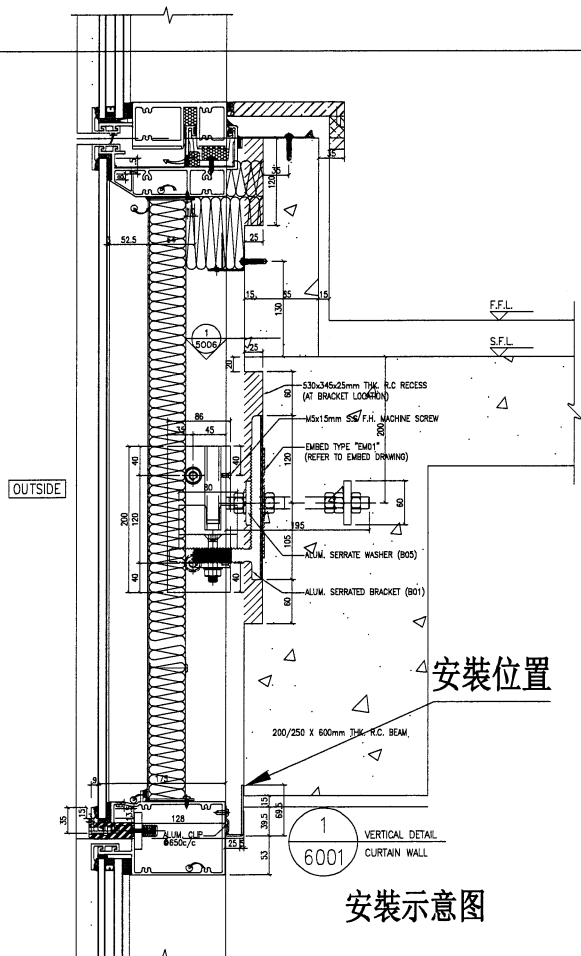
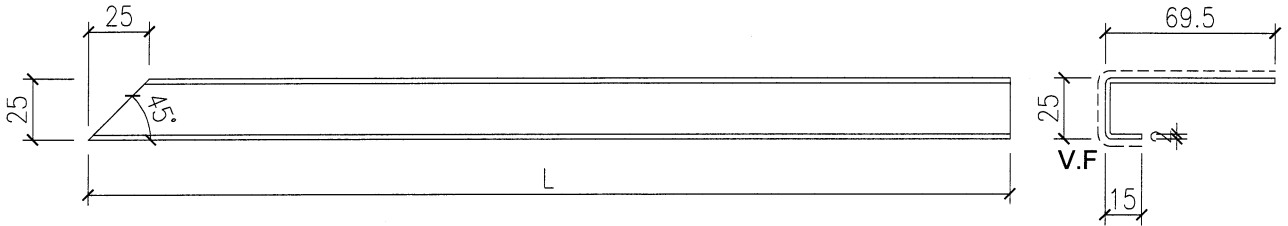



美特鋁質有限公司  
MIDI Aluminium Fabricator Ltd.

工程號 J-853 地盤 延坪道住宅

序號	物料編號	L	數量	位置	分格尺寸	樓層	樓層數	每層數量	座數
1	W-MC01-211	2510	1	J853-SD-CW-4203右	2600	23/F	1	1	T2
2	W-MC01-303	2510	1	J853-SD-CW-4301右	2600	23/F	1	1	T3
		總數：	2						

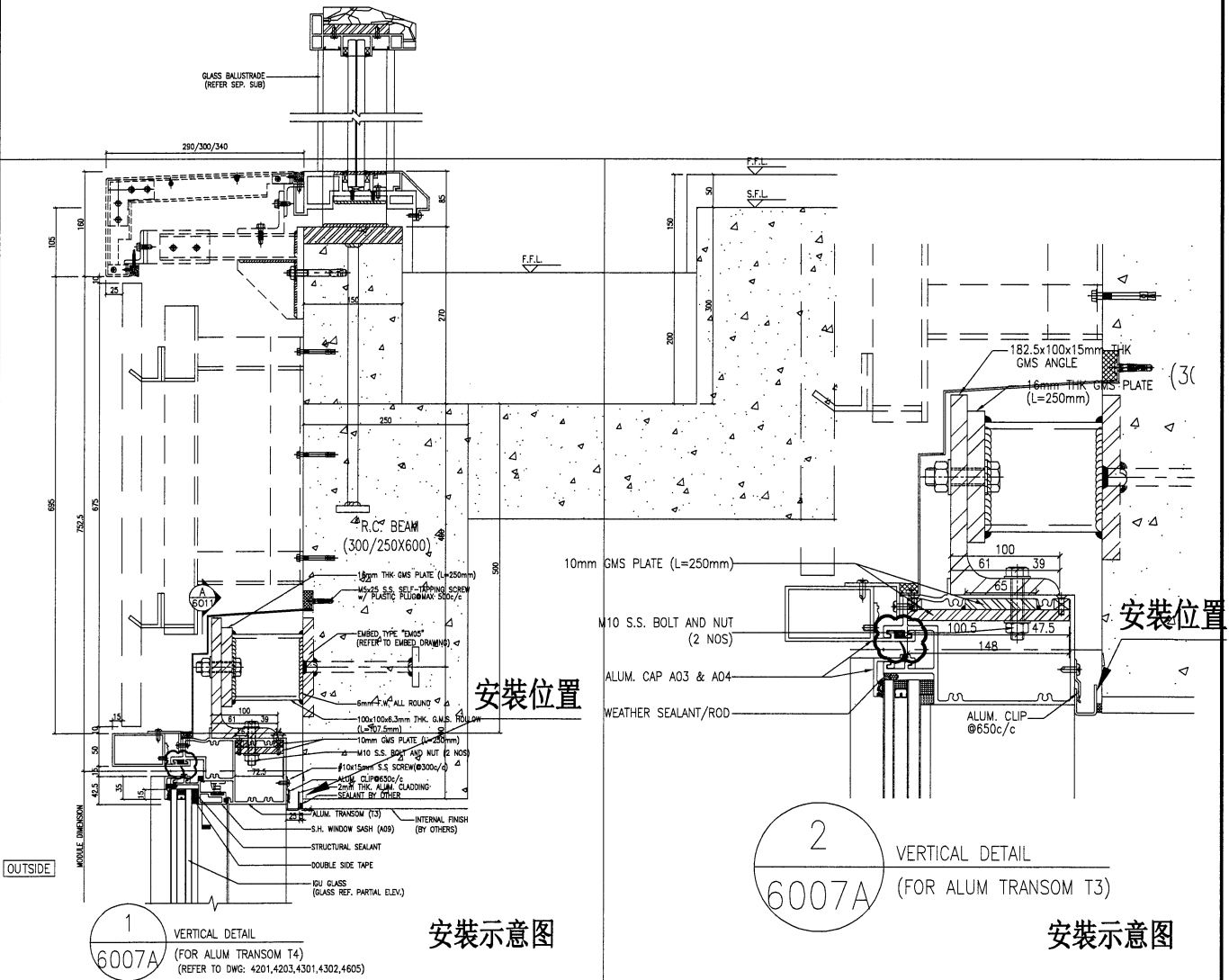
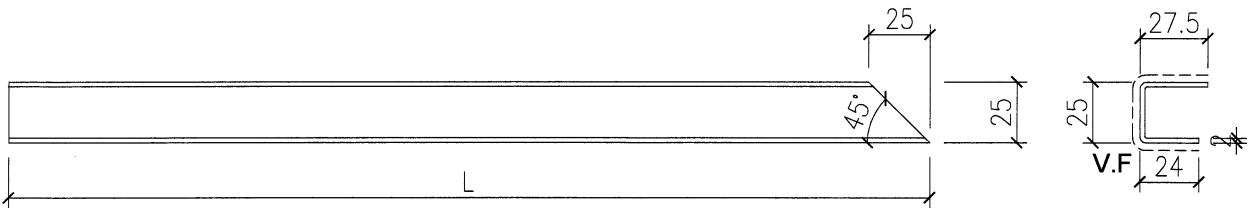

名稱	轉角橫向收口鋁板	制圖	方強	2023. 04. 10	修改		
材料	2mm鋁板	復核	謝永林	2023. 04. 20	日期		
顏色	EC-DG-D334232-ZD1 (閃粉古銅)	批准	Daniel		圖號	W-MC01-211	

工程號	J-853	地盤	延坪道住宅
-----	-------	----	-------

序號	物料編號	L	數量	位置	分格尺寸	樓層	樓層數	每層數量	座數
1	W-MC01-210	710	1	J853-SD-CW-4203右	815	23/F	1	1	T2
2	W-MC01-302	710	1	J853-SD-CW-4301右	815	23/F	1	1	T3
			總數：	2					

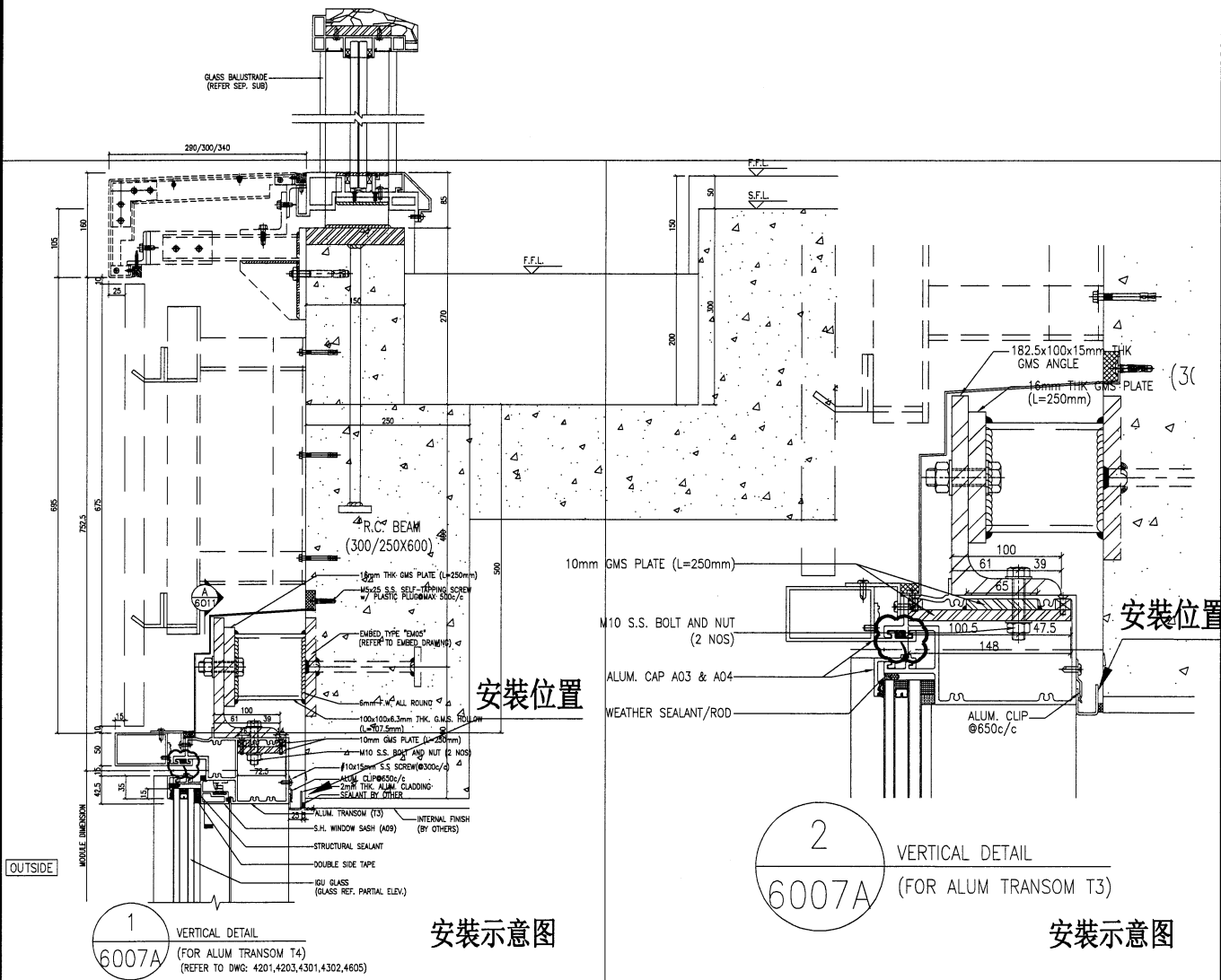
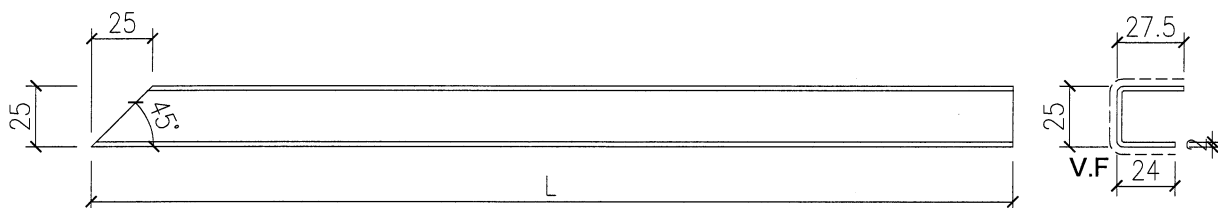

名稱	轉角橫向收口鋁板	制圖	方強	2023. 04. 10	修改		
材料	2mm鋁板	復核	謝永林	2023. 04. 20	日期		
顏色	EC-DG-D334232-ZD1 (閃粉古銅)	批准	Daniel		圖號	W-MC01-210	

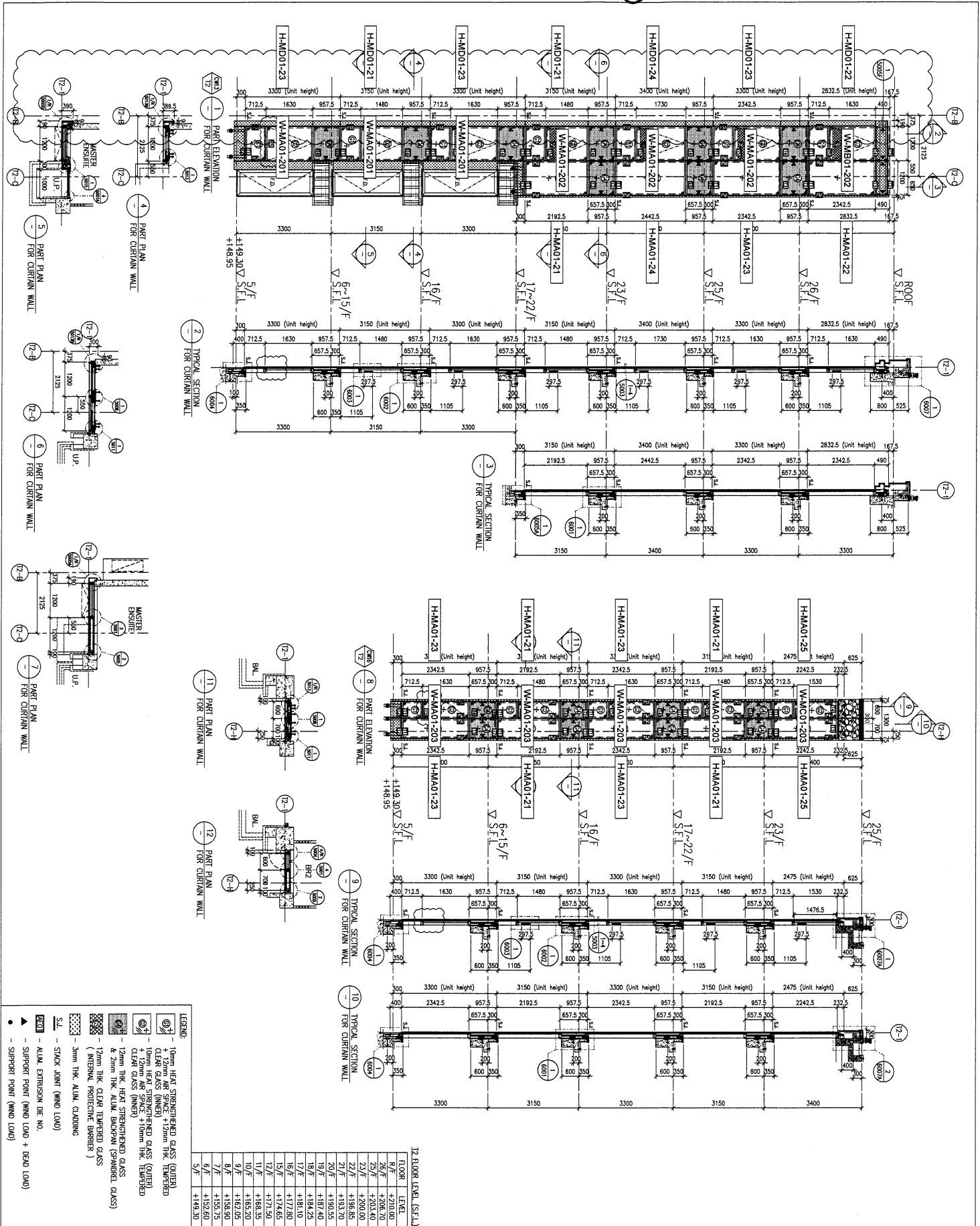

**CLIENT:** SHIMAO GROUP HOLDINGS LIMITED

**ARCHITECT:** WONG TUNG & PARTNERS LIMITED

**MAIN CONTRACTOR:** 協興建築有限公司  
HP HING CONSTRUCTION CO LTD

**STRUCTURAL ENGINEER:** C M WONG & ASSOCIATES LTD  
黃志明建築工程師有限公司

**FAO&E CONSULTANT:** WENHARDT

**NOTE:**  
1. ALL DIMENSIONS ARE IN mm.  
2. ALL DIMENSIONS ARE VIEWED FROM OUTSIDE.  
3. ALL DIMENSIONS TO BE VERIFIED ON SITE BEFORE FABRICATION.

**LEGEND:**  
A1 DETAIL MARK NO.  
REF. SHEET NO.  
1. F.F.L. — FINISHED FLOOR LEVEL.  
2. S.F.L. — STRUCTURAL FLOOR LEVEL.  
3. (R) — REVERSED DETAIL.

**LEGEND:**  
① 10mm HEAT STRENGTHENED GLASS (OUTER)  
② 10mm CLEAR GLASS (INNER)  
③ 10mm HEAT STRENGTHENED GLASS (OUTER) + 12mm AIR SPACE + 10mm HEAT STRENGTHENED GLASS (INNER)  
④ 12mm THK. HEAT STRENGTHENED GLASS (INTERNAL PROTECTIVE BARRIER)  
⑤ 12mm THK. CLEAR TEMPERED GLASS  
& 2mm THK. ALUM. BACKSPAN (SPANDREL GLASS)  
⑥ 3mm THK. ALUM. CLADDING  
⑦ STACK JOINT (WIND LOAD)  
⑧ ALUM. EXTRUSION (WIND LOAD)  
⑨ SUPPORT POINT (WIND LOAD) + (DEAD LOAD)  
⑩ SUPPORT POINT (WIND LOAD)

**TITLE:** PART ELEVATION FOR CURTAIN WALL AT TOWER 2

**DATE:** 26-MAR-21 **SCALE:** 1:60 (A1)

**DESIGN BY:** LHR **CHECKED BY:** [Signature]

**PROJECT:** PROPOSED RESIDENTIAL DEVELOPMENT AT N.K.I.L. 6542 YIN PING ROAD KOWLOON

**JOB NO.:** J-853

**DATE:** 06-10-2021

**REVISION SUBJECT TO ARCH. COMMENT**

**DATE:** 06-10-2021

**REV.:** C

**UNITED ENGINEERING CONSULTANTS (U.E.C.)**  
610 Chee Koo Ling Road, Kowloon  
Tel: (852) 2489211-4 Fax: (852) 27275665  
DWC NO.: 1853-SI-CW-4201

LEGEND :  
R.S. = RESTRAINT SOCKET

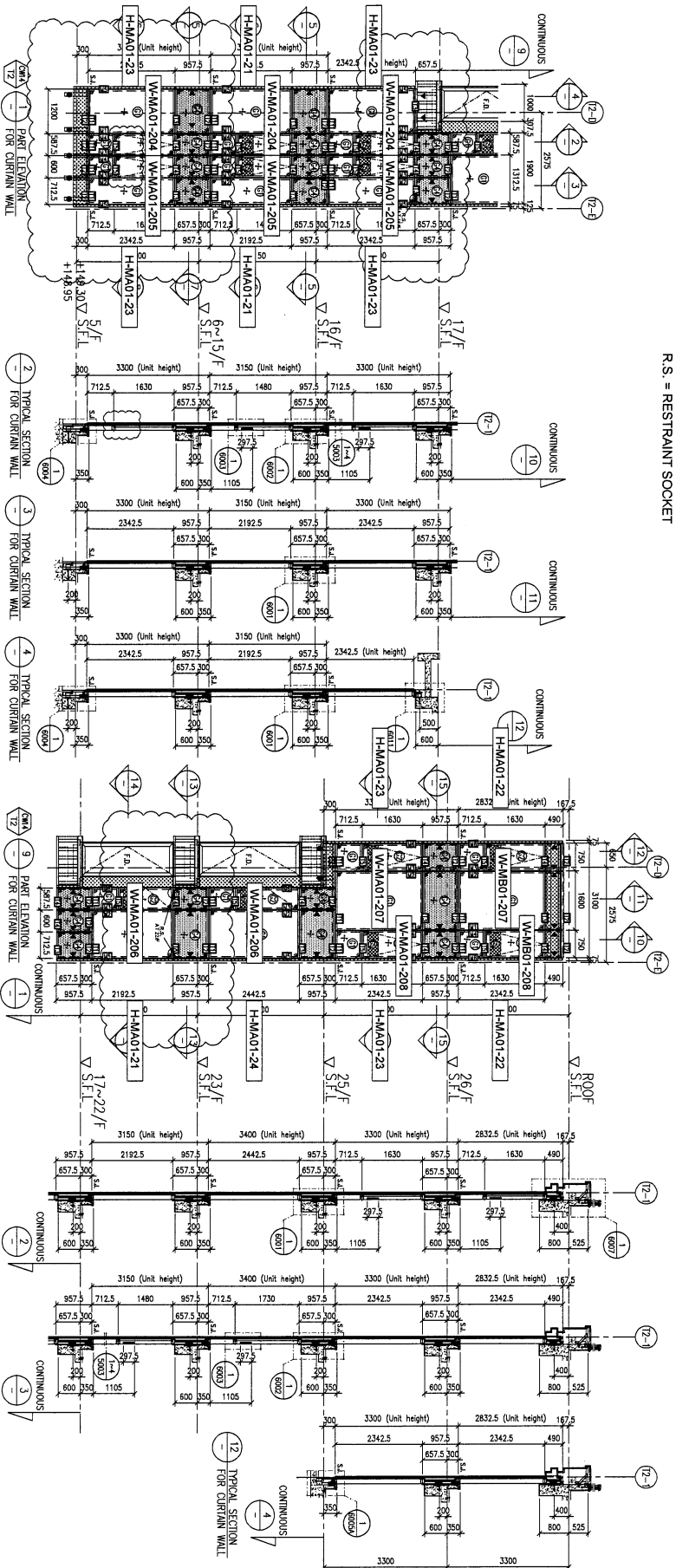

左: 間牆位用鋁板: 2隻/層

H-MC01-21 (6-15/F)  
H-MC01-23 (5/F, 16/F)

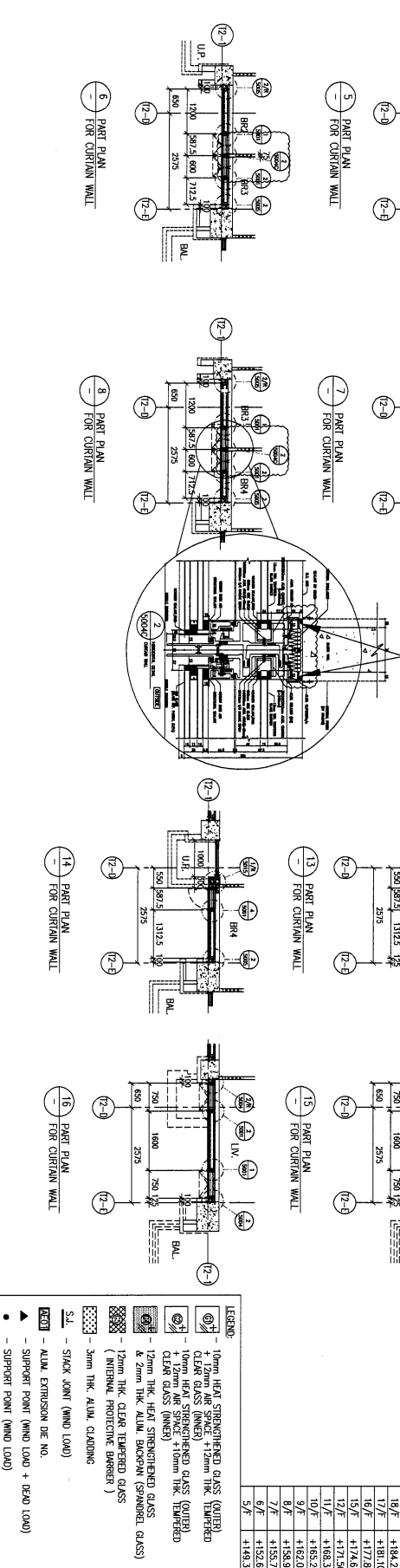

12 FLOOR LEVEL (S.F.L.)

FLOOR	LEVEL
R/F	+210.00
26/F	+206.70
25/F	+203.40
22/F	+200.00
21/F	+196.85
20/F	+193.70
19/F	+190.55
18/F	+187.40
17/F	+184.25
16/F	+181.10
15/F	+177.95
12/F	+174.80
11/F	+171.65
10/F	+168.50
9/F	+165.20
8/F	+162.05
7/F	+158.90
6/F	+155.75
5/F	+152.60
	+149.50

- LEGEND:
- 10mm HEAT STRENGTHENED GLASS (OUTER)
  - 10mm HEAT STRENGTHENED GLASS (INNER)
  - 10mm HEAT STRENGTHENED GLASS (OUTER) + 12mm HEAT STRENGTHENED GLASS (INNER)
  - 12mm HEAT STRENGTHENED GLASS (OUTER) + 12mm HEAT STRENGTHENED GLASS (INNER)
  - 12mm HEAT STRENGTHENED GLASS (OUTER) + 12mm HEAT STRENGTHENED GLASS (INNER) (INTERIOR PROTECTIVE BARBER)
  - 12mm HEAT STRENGTHENED GLASS (OUTER) + 23mm HEAT STRENGTHENED GLASS (INNER) (SARGOL GLASS)
  - 12mm HEAT STRENGTHENED GLASS (OUTER) + 23mm HEAT STRENGTHENED GLASS (INNER) (SARGOL GLASS)
  - S.L. - STACK JOINT (WIND LOAD)
  - ALUM. EXTENSION DET. NO.
  - SUPPORT POINT (WIND LOAD + BEAD LOAD)
  - SUPPORT POINT (WIND LOAD)

BD REF.:

CLIENT: SHIMAO GROUP HOLDINGS LIMITED

ARCHITECT: WONG TUNG & PARTNERS LIMITED

MAIN CONTRACTOR: 協興建築有限公司 HIP HING CONSTRUCTION CO LTD

STRUCTURAL ENGINEER: C.M.A. C.M.WONG & ASSOCIATES LTD 黃志明建築工程師有限公司

FAÇADE CONSULTANT: MENHARDT

NOTE: 1. ALL DIMENSIONS ARE IN MM. 2. ALL ELEVATIONS ARE VIEWED FROM OUTSIDE. 3. ALL DIMENSIONS TO BE CHECKED ON SITE BEFORE FABRICATION.

LEGEND: 1. DETAIL MARK NO. 2. REFER SHEET NO. 3. F.F.L. - FINISHED FLOOR LEVEL. 4. S.F.L. - STRUCTURAL FLOOR LEVEL. 5. - REVERSED DETAIL.

PROJECT: PROPOSED RESIDENTIAL DEVELOPMENT AT N.K.I.L. 6542 YIN PING ROAD KOWLOON

TITLE: PART ELEVATION FOR CURTAIN WALL AT TOWER 2

DATE: 26-MAR-21 SCALE: 1:60 (A1)

DRAWN BY: LHR CHECKED BY:

DATE: 06-04-2021 REVISION SUBJECT TO ARCH. COMMENT

NO. DATE REVISION BY

J-853

REV.: B

美特銘有限公司  
M.T.M. Engineering & Architecture Ltd.  
Unit 5-8, Shek Kwoi Road, Kowloon  
Tel: (852) 27717665 Fax: (852) 27717665  
DWC NO.: J853-SI-CW-4202



LEGEND:  
R.S. = RESTRAINT SOCKET

39

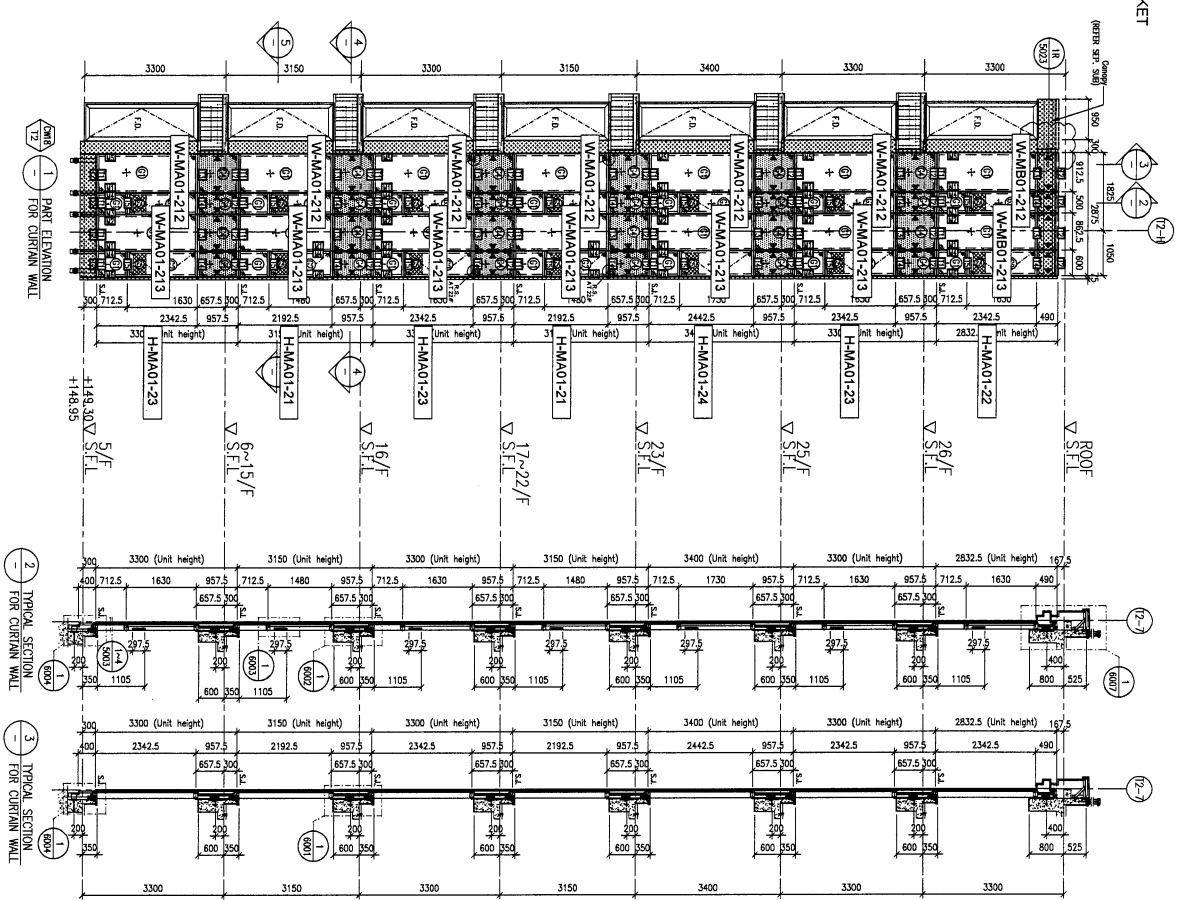

間牆位用鋁板: 2隻/層

H-MC01-21	(6-15/F, 17-22/F)
H-MC01-22	(26/F)
H-MC01-23	(5/F, 16/F, 25/F)
H-MC01-24	(23/F)

FLOOR LEVEL (S.F.L.)	LENS
ROOF	+210.00
26/F	+206.70
25/F	+203.40
23/F	+200.00
22/F	+196.85
21/F	+193.70
20/F	+190.55
19/F	+187.40
18/F	+184.25
17/F	+181.10
16/F	+177.80
15/F	+174.65
12/F	+171.50
11/F	+168.35
10/F	+165.20
9/F	+162.05
8/F	+158.90
7/F	+155.75
6/F	+152.60
5/F	+149.50

LEGEND:

- 10mm HEAT STRENGTHENED GLASS (OUTER)
- 12mm HEAT STRENGTHENED GLASS (INNER)
- 10mm HEAT STRENGTHENED GLASS (OUTER)
- 12mm HEAT STRENGTHENED GLASS (INNER)
- 12mm THK. CLEAR TEMPERED GLASS
- 8mm THK. ALUM. BACKSPAN (SPRINKLER GLASS)
- 8mm THK. ALUM. BACKSPAN (SPRINKLER GLASS)
- INTERNAL PROTECTIVE BARBERS
- 3mm THK. ALUM. CLADDING
- STACK JOINT (WIND LOAD)
- ALUM. EXTENSION DE. NO.
- SUPPORT POINT (WIND LOAD) + DEAD LOAD
- SUPPORT POINT (WIND LOAD)

NOTE:

- ALL DIMENSIONS ARE IN mm.
- ALL DIMENSIONS TO BE CHECKED FROM OUTSIDE.
- BEFORE FABRICATION.

LEGEND:

- DETAIL MARK NO.
- REFER SHEET NO.
- FINISHED FLOOR LEVEL
- STRUCTURAL FLOOR LEVEL
- REVERSED DETAIL

CLIENT: SHIMAO GROUP HOLDINGS LIMITED

ARCHITECT: HONG TUNG & PARTNERS LIMITED

MAIN CONTRACTOR: 協興建築有限公司 HPH HING CONSTRUCTION CO LTD

STRUCTURE ENGINEER: C.M. WONG & ASSOCIATES LTD 黃志明建築工程師有限公司

FAÇADE CONSULTANT: MENYARDT

PROJECT: PROPOSED RESIDENTIAL DEVELOPMENT AT N.K.I.L. 6542 YIN PING ROAD KOWLOON

DRAWN BY: LHR

CHECKED BY: [Signature]

DATE: 26-MAR-21

SCALE: 1:60 (A1)

TITLE: PART ELEVATION FOR CURTAIN WALL AT TOWER 2

JOB NO.: J-853

REVISION:

NO.	DATE	REVISION	BY
1	06-10-2021	ISSUED SUBJECT TO ARCH. CONTRACT	HR

REV.: B

美特銘實業有限公司  
M.T. REALTY DEVELOPMENT LTD.  
610 Chee Koo Ling Road, Kowloon  
Tel: 24248271-4 Fax: (852) 27276865  
DWG NO.: 1853-SI-CW-4204



LEGEND:  
R.S. = RESTRAINT SOCKET

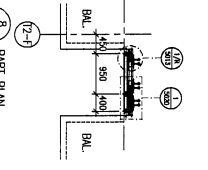
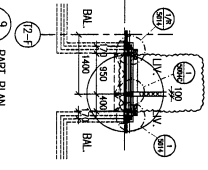
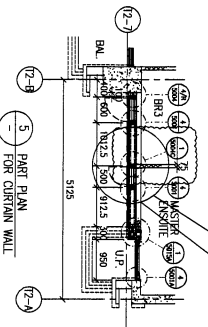
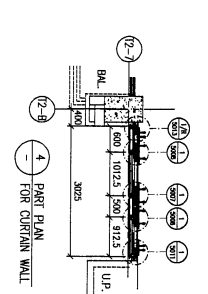
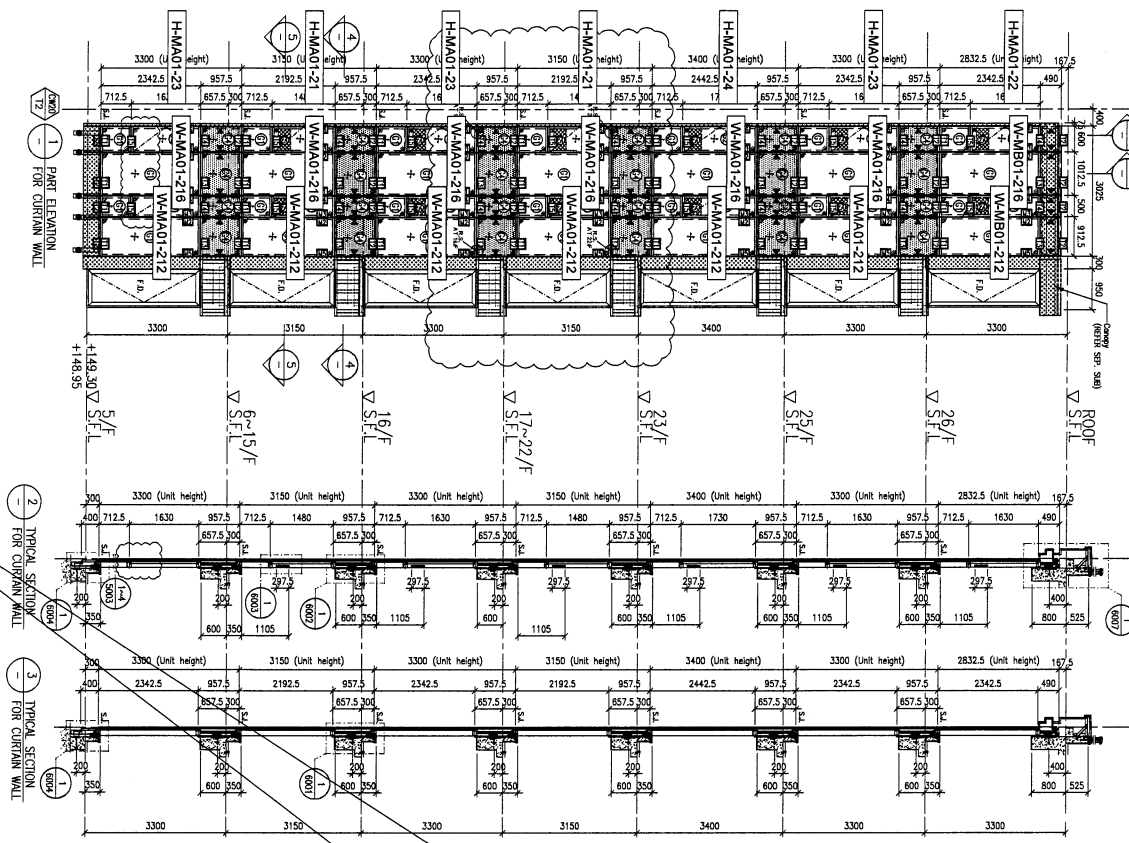

左:間牆位用鋁板:2隻/層

- H-MC01-21 (6-15/F, 17-22/F)
- H-MC01-22 (26/F)
- H-MC01-23 (5/F, 16/F, 25/F)
- H-MC01-24 (23/F)

右:間牆位用鋁板:2隻/層

- H-MC01-21 (6-15/F)
- H-MC01-23 (16/F)

- LEGEND:
- ① 10mm HEAT STRENGTHENED GLASS (OUTER)
  - ② 12mm AIR SPACE + 12mm THK. TEMPERED CLEAR GLASS (INNER)
  - ③ 12mm HEAT STRENGTHENED GLASS (OUTER) + 12mm AIR SPACE + 10mm THK. TEMPERED CLEAR GLASS (INNER)
  - ④ 12mm THK. HEAT STRENGTHENED GLASS & 2mm THK. ALUM. BARRIAGE (SPANDREL GLASS) (INTERNAL PROTECTIVE BARRIER)
  - ⑤ 3mm THK. ALUM. CLADDING
  - S.L. STICK JOINT (WIND LOAD)
  - ALUM. EXTRUSION DIE NO.
  - ▲ SUPPORT POINT (WIND LOAD + DEAD LOAD)
  - SUPPORT POINT (WIND LOAD)

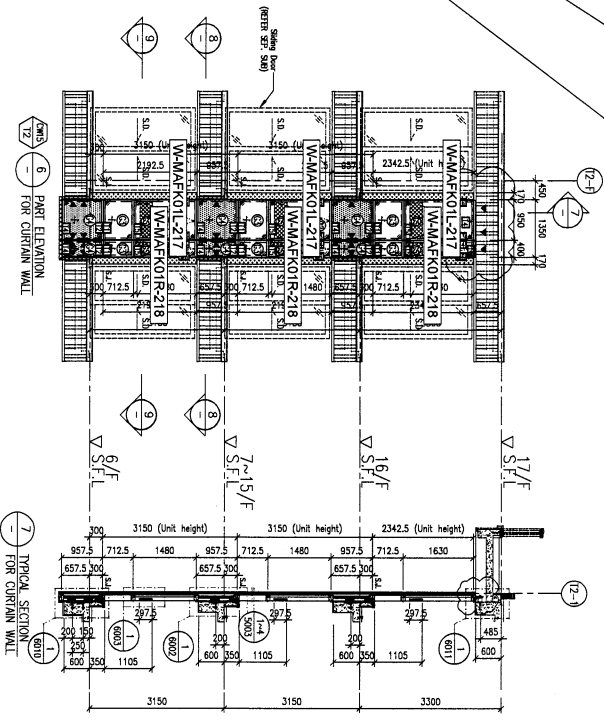

FLOOR LEVEL (S.F.L.)	LEVEL
ROOF	+210.00
26/F	+205.70
25/F	+203.40
23/F	+200.00
22/F	+196.85
21/F	+193.70
20/F	+190.55
19/F	+187.40
18/F	+184.25
17/F	+181.10
16/F	+177.80
15/F	+174.65
12/F	+171.50
11/F	+168.35
10/F	+165.20
9/F	+162.05
8/F	+158.90
7/F	+155.75
6/F	+152.60
5/F	+149.50

NOTE:  
1. DIMENSIONS ARE IN mm.  
2. ALL DIMENSIONS ARE MEASURED FROM OUTSIDE BEFORE FABRICATION.  
3. ALL DIMENSIONS TO BE CHECKED ON SITE.

STRUCTURAL ENGINEER:  
**CMA** C.M.WONG & ASSOCIATES LTD  
黃志明建築工程師有限公司

FAÇADE CONSULTANT:  
**WENHARDT**

ARCHITECT:  
**WTF** WONG TUNG & PARTNERS LIMITED

MAIN CONTRACTOR:  
**SHIMAO GROUP HOLDINGS LIMITED**  
協興建築有限公司  
HP HING CONSTRUCTION CO LTD

CLIENT:  
**SHIMAO GROUP HOLDINGS LIMITED**

DATE: 26-MAR-21 SCALE: 1:60 (A1)  
DRAWN BY: LHR CHECKED BY:  
PROJECT: PROPOSED RESIDENTIAL DEVELOPMENT AT N.K.I.L. 6542 YIN PING ROAD KOWLOON

TITLE: PART ELEVATION FOR CURTAIN WALL AT TOWER 2

DATE: 26-MAR-21 SCALE: 1:60 (A1)  
DRAWN BY: LHR CHECKED BY:  
PROJECT: PROPOSED RESIDENTIAL DEVELOPMENT AT N.K.I.L. 6542 YIN PING ROAD KOWLOON

UNIT: 6-8, Sheung Yee Road, Kowloon  
Unit 610 Chee Kwo Ling Road, Kowloon  
Tel: 23489211-4 Fax: (852) 27272665  
DWG NO.: 1853-SF-CW-4205 REV.: B

美特鋁質有限公司  
M.T. Aluminium Extrusion Ltd.  
610 Chee Kwo Ling Road, Kowloon  
Tel: 23489211-4 Fax: (852) 27272665  
DWG NO.: 1853-SF-CW-4205 REV.: B

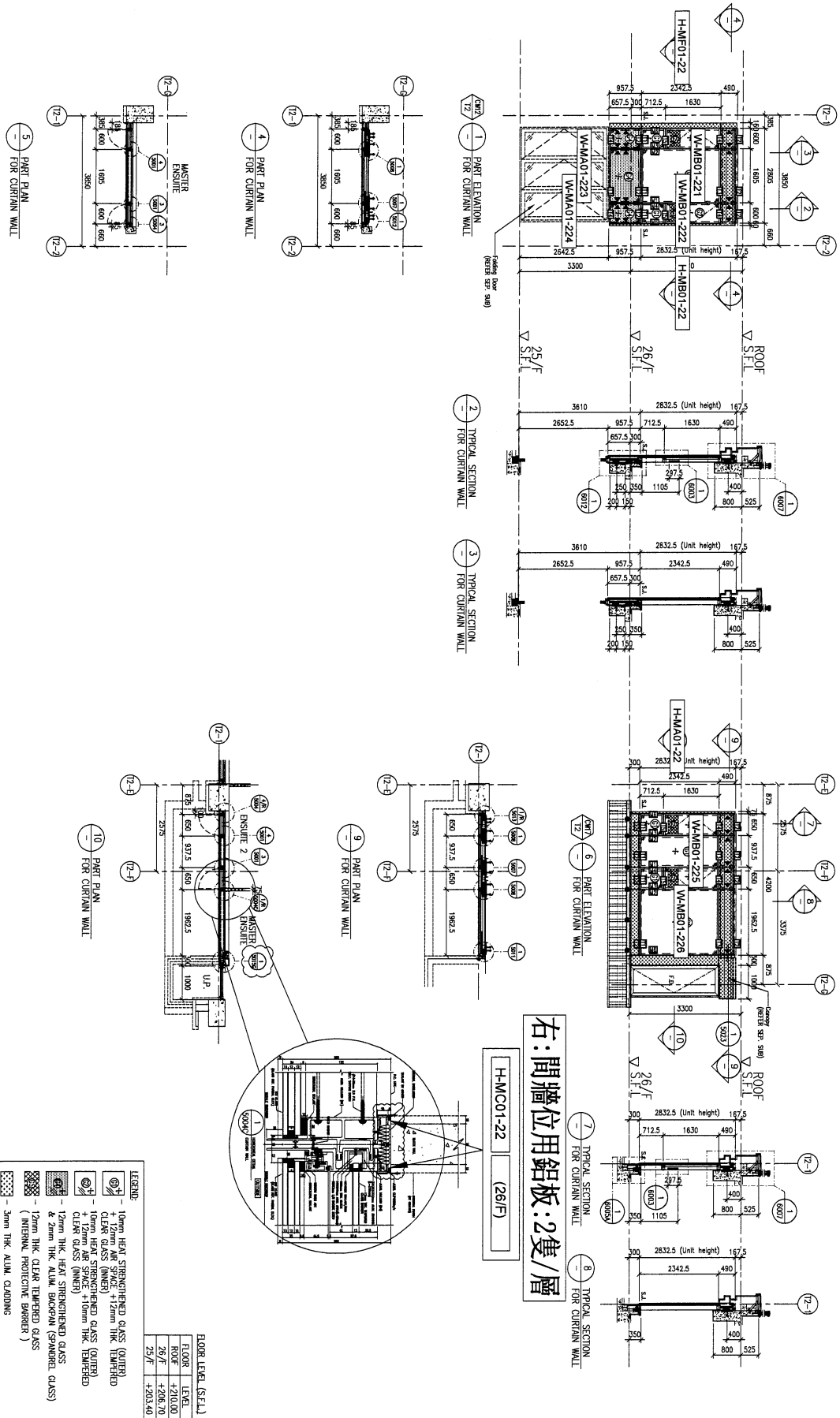

右: 間牆位用鋁板: 2隻/層

H-MC01-22 (26/F)

FLOOR LEVEL (S.S.L.)	FLOOR LEVEL
ROOF	+210.00
26/F	+206.70
25/F	+203.40

- LEGEND:**
- 10mm HEAT STRENGTHENED GLASS (OUTER)
  - 10mm HEAT STRENGTHENED GLASS (INNER)
  - 10mm HEAT STRENGTHENED GLASS (OUTER) + 12mm AIR SPACE + 10mm HEAT STRENGTHENED GLASS (INNER)
  - 12mm HEAT STRENGTHENED GLASS & 23mm HEAT STRENGTHENED GLASS (SYMMETRICAL GLASS)
  - 12mm THK. CLEAR TEMPERED GLASS (INTERNAL PROTECTIVE BARRIER)
  - 3mm THK. ALUM. CLADDING
  - STACK JOINT (WIND LOAD)
  - ALUM. EXTENSION (DE NO.)
  - SUPPORT POINT (WIND LOAD + DEAD LOAD)
  - SUPPORT POINT (WIND LOAD)

**CLIENT :** SHIMAO GROUP HOLDINGS LIMITED

**ARCHITECT :** WONG TUNG & PARTNERS LIMITED

**MAIN CONTRACTOR :** 協興建築有限公司 HIP HING CONSTRUCTION CO LTD

**STRUCTURAL ENGINEER :** CMA C M WONG & ASSOCIATES LTD 黃志明建築工程師有限公司

**FAÇADE CONSULTANT:** MENHARDT

**NOTE:**

- ALL DIMENSIONS ARE IN mm.
- ALL ELEVATIONS ARE VIEWED FROM OUTSIDE.
- ALL DIMENSIONS TO BE VERIFIED ON SITE BEFORE FABRICATION.

**LEGEND:**

- DETAIL MARK NO.
- FIBER SHEET NO.
- F.F.L. --- FINISHED FLOOR LEVEL.
- S.F.L. --- STRUCTURAL FLOOR LEVEL.
- REVERSED DETAIL.

NO.	DATE	REVISION
1		

**JOB NO.:** J-853

**PROJECT:** PROPOSED RESIDENTIAL DEVELOPMENT AT N.K.I.L. 6542 YIN PING ROAD KOWLOON

**TITLE:** PART ELEVATION FOR CURTAIN WALL AT TOWER 2

**DATE:** 05-OCT-21 **SCALE:** 1:60 (A1)

**DRAWN BY:** LHR **CHECKED BY:**

**SHIMAO GROUP HOLDINGS LIMITED**  
 610 Chee Kwo Ling Road, Kowloon  
 Tel: (852) 4892711-4 Fax: (852) 2777866

**WONG TUNG & PARTNERS LIMITED**  
 177 Des Voeux Road, Hong Kong  
 Tel: (852) 25222222 Fax: (852) 25222222

**CMA C M WONG & ASSOCIATES LTD**  
 177 Des Voeux Road, Hong Kong  
 Tel: (852) 25222222 Fax: (852) 25222222

**MENHARDT**

REV.: B





LEGEND :  
R.S. = RESTRAINT SOCKET

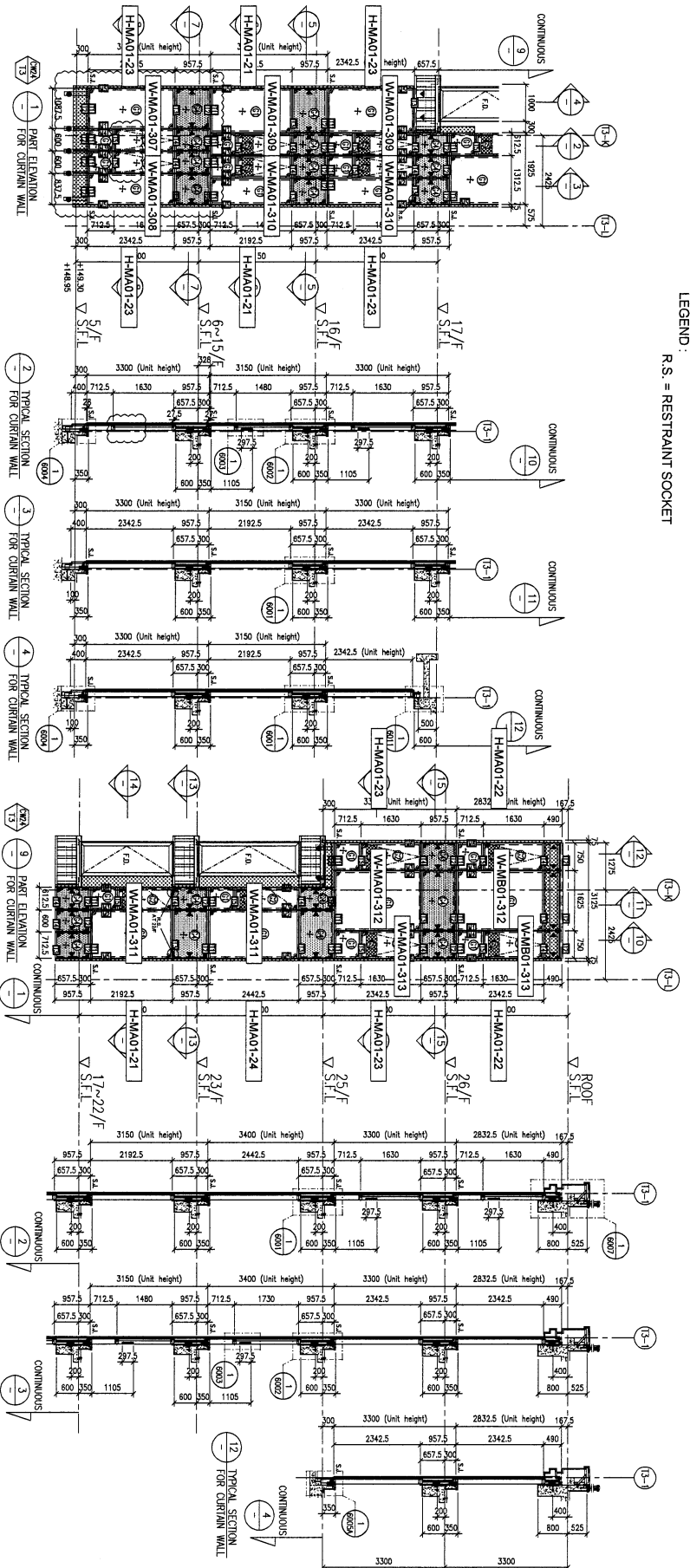

左: 間牆位用鋁板: 2隻/層

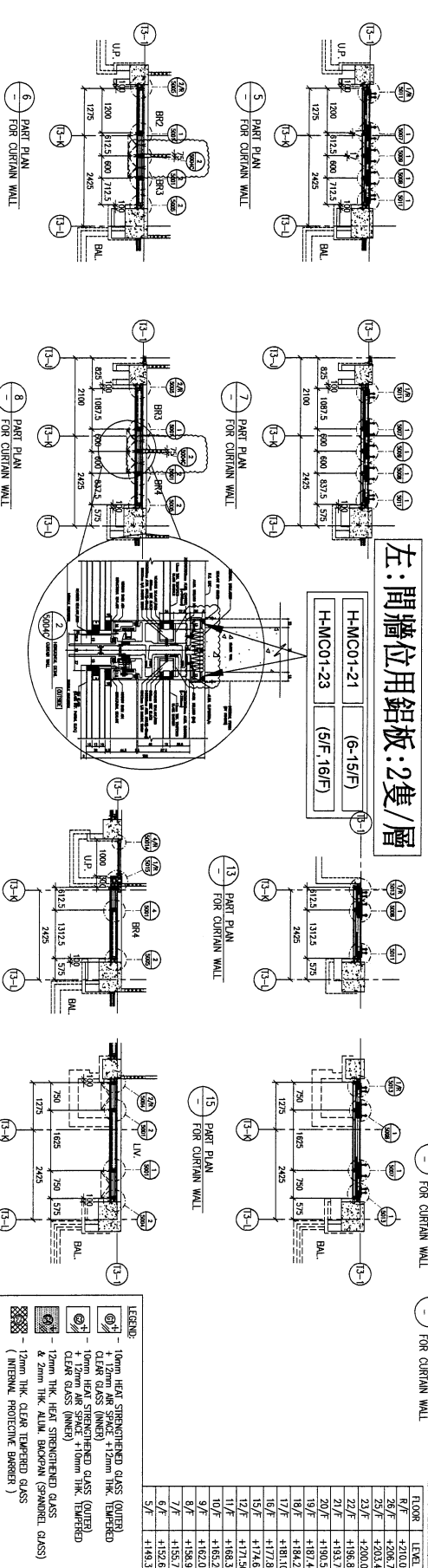

12 FLOOR LEVEL (S.F.L.)

FLOOR	LEAD
6/F	+210.00
7/F	+206.70
8/F	+203.40
9/F	+200.00
10/F	+196.85
11/F	+193.70
12/F	+190.55
13/F	+187.40
14/F	+184.25
15/F	+181.10
16/F	+177.90
17/F	+174.65
18/F	+171.50
19/F	+168.35
20/F	+165.20
21/F	+162.05
22/F	+158.90
23/F	+155.75
24/F	+152.60
25/F	+149.50

- LEGEND:
- 10mm HEAT STRENGTHENED GLASS (OUTER)
  - 10mm HEAT STRENGTHENED GLASS (INNER)
  - 12mm CLEAR TEMPERED GLASS (OUTER)
  - 12mm CLEAR TEMPERED GLASS (INNER)
  - 12mm CLEAR TEMPERED GLASS (INTERMEDIATE PROTECTIVE BARRIER)
  - 3mm THK. ALUM. CLADDING
  - STACK JOINT (WIND LOAD)
  - ALUM. EXPANSION JOINT (NO SUPPORT POINT (WIND LOAD + DEAD LOAD))
  - ALUM. EXPANSION JOINT (WITH SUPPORT POINT (WIND LOAD + DEAD LOAD))

BD. REF. : \_\_\_\_\_

CLIENT : SHIMAO GROUP HOLDINGS LIMITED

ARCHITECT : WONG TUNG & PARTNERS LIMITED

STRUCTURAL ENGINEER : CMA C.M. WONG & ASSOCIATES LTD 黃志明建築工程師有限公司

MEINHARDT

PROJECT : PROPOSED RESIDENTIAL DEVELOPMENT AT N.K.I.L. 6542 YIN PING ROAD KOWLOON

DATE : 26-MAR-21 SCALE : 1:60 (A1)

DRWN BY : LHR CHECKED BY : \_\_\_\_\_

REVISION SUBJECT TO ARCH. COMMENT

REV. : B



LEGEND:  
R.S. = RESTRAINT SOCKET

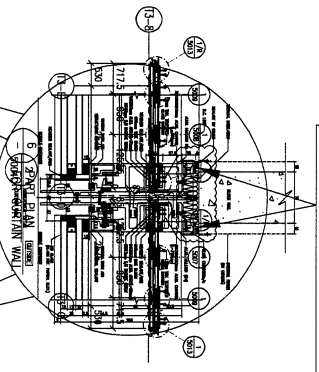
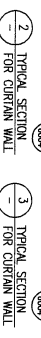
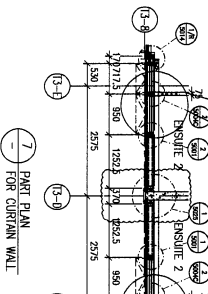
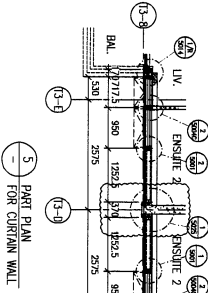
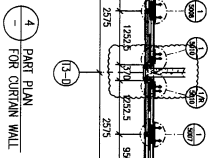
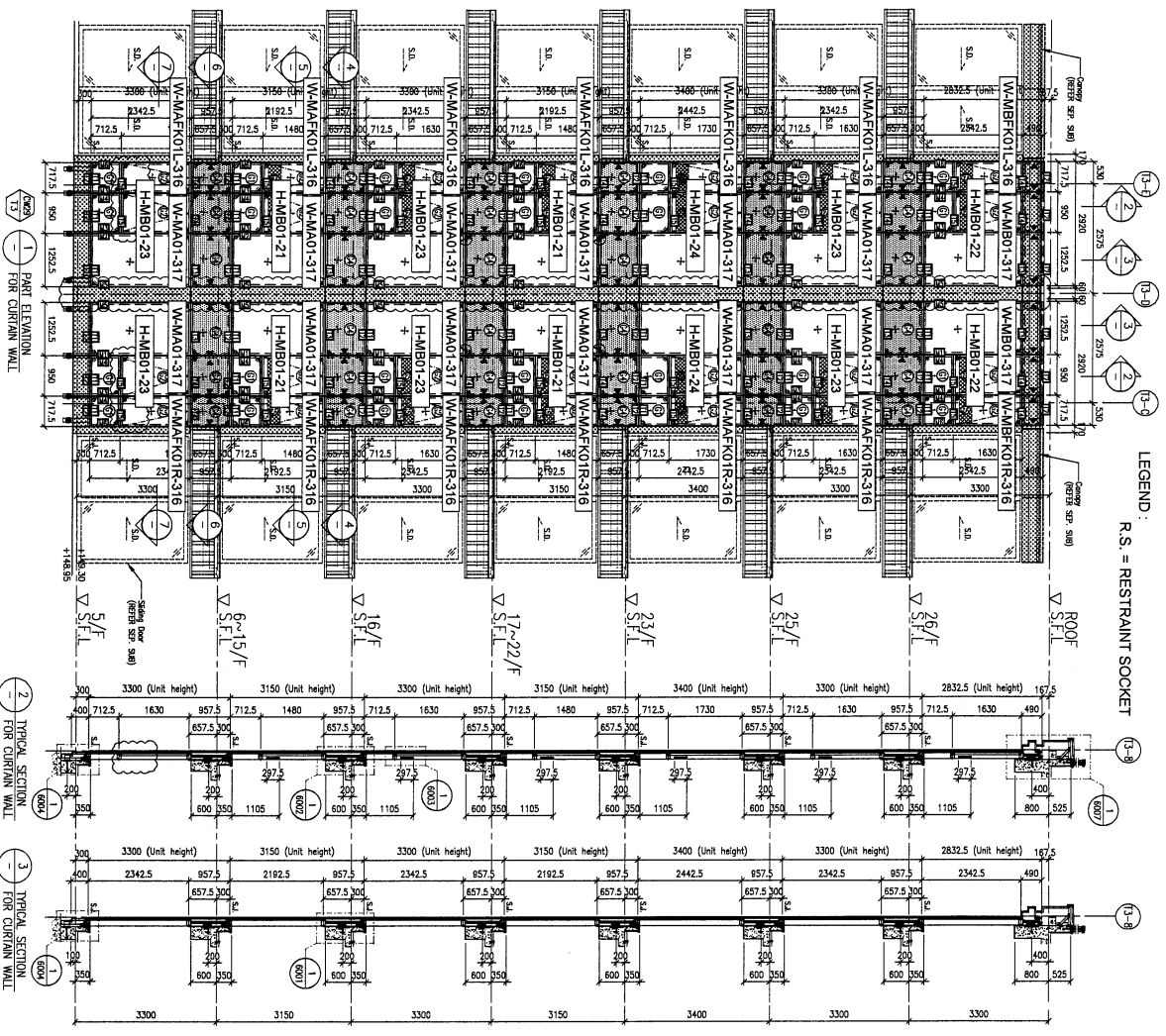

間牆位用鋁板: 4隻/層

H-MC01-21	(6-15/F, 17-22/F)
H-MC01-22	(26/F)
H-MC01-23	(5/F, 16/F, 25/F)
H-MC01-24	(23/F)

FLOOR LEVEL (S.F.L.)	ELEV.
ROOF	+210.00
26/F	+206.70
25/F	+203.40
23/F	+200.00
22/F	+196.85
21/F	+193.70
20/F	+190.55
19/F	+187.40
18/F	+184.25
17/F	+181.10
16/F	+177.90
15/F	+174.65
12/F	+171.50
11/F	+168.35
10/F	+165.20
9/F	+162.05
8/F	+158.90
7/F	+155.75
5/F	+152.60
	+149.50

NOTE:  
1. ALL DIMENSIONS ARE IN mm.  
2. ALL ELEVATIONS ARE MEASURED FROM OUTSIDE.  
3. ALL DIMENSIONS TO BE VERIFIED ON SITE BEFORE FABRICATION.

LEGEND:  
 DETAIL MARK NO.  
 REVERSED SHEET NO.  
 F.F.L. --- FINISHED FLOOR LEVEL  
 S.F.L. --- STRUCTURAL FLOOR LEVEL  
 (R) --- REVERSED DETAIL

LEGEND:  
 10mm HEAT STRENGTHENED GLASS (OUTER)  
 10mm CLEAR GLASS (INNER)  
 10mm AIR SPACED +10mm THK. TEMPERED GLASS (OUTER)  
 12mm HEAT STRENGTHENED GLASS (INNER)  
 12mm THK. CLEAR TEMPERED GLASS (SHORELAND GLASS)  
 6mm THK. ALUM. BACKPAN (SHORELAND GLASS)  
 3mm THK. ALUM. GLAZING  
 STACK JOINT (WIND LOAD)  
 ALUM. EXTENSION DE NO.  
 SUPPORT POINT (WIND LOAD + DEAD LOAD)  
 SUPPORT POINT (WIND LOAD)

BD. REF :  
 CLIENT : SHIMAO GROUP HOLDINGS LIMITED  
 ARCHITECT : HOKI TAKI & PARTNERS LIMITED  
 MAIN CONTRACTOR : 協興建築有限公司  
 STRUCTURAL ENGINEER : C.M. WONG & ASSOCIATES LTD  
 FACADE CONSULTANT : MENYHARDT

PROJECT : PROPOSED RESIDENTIAL DEVELOPMENT AT N.K.I.L. 6542 YIN PING ROAD KOWLOON  
 JOB NO. : J-853  
 DATE : 06-10-2011  
 DRAWN BY : LHR  
 CHECKED BY :  
 DATE : 23-OCT-21  
 SCALE : 1:60 (A1)  
 TITLE : PART ELEVATION FOR CURTAIN WALL AT TOWER 3  
 DWG NO. : 1853-SI-CW-4304A  
 REV. : B

DATE : 23-OCT-21  
 SCALE : 1:60 (A1)  
 TITLE : PART ELEVATION FOR CURTAIN WALL AT TOWER 3  
 DWG NO. : 1853-SI-CW-4304A  
 REV. : B



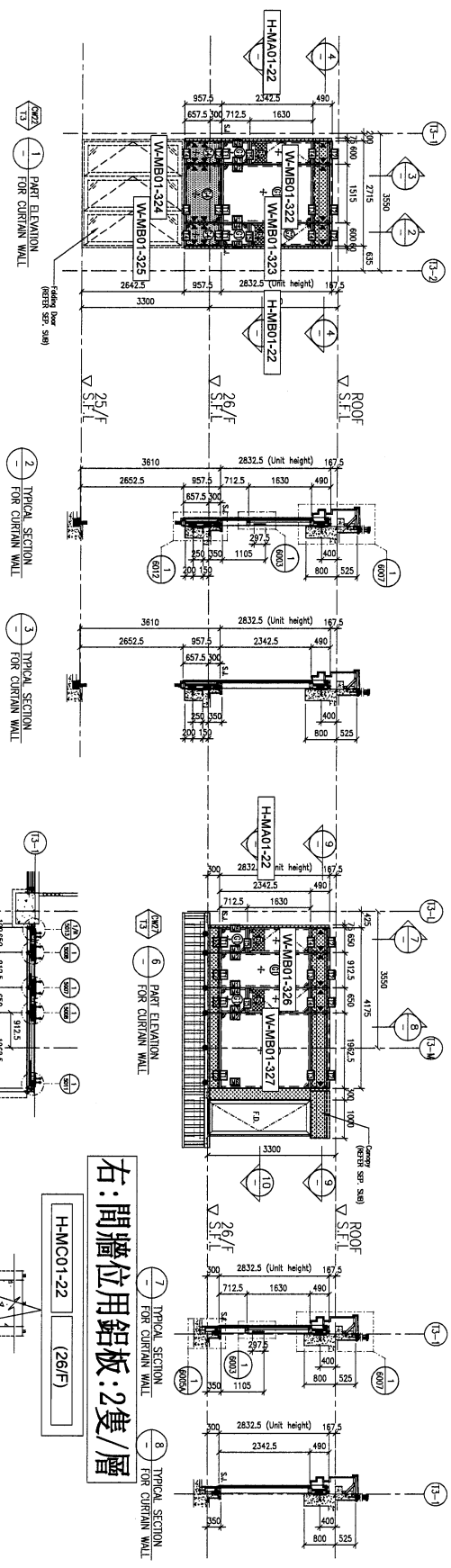

右: 間牆位用鋁板: 2隻/層

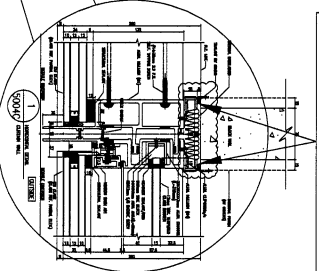
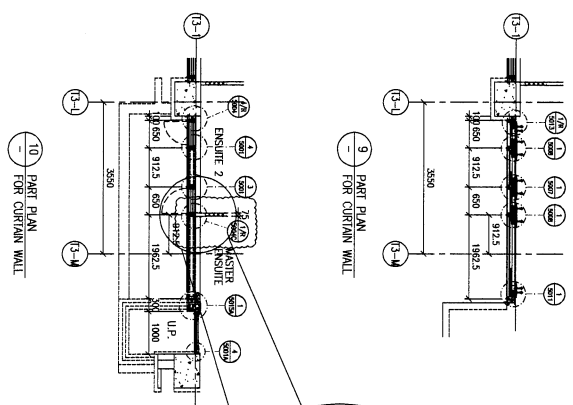
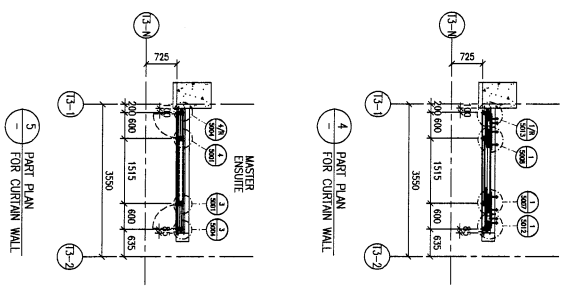

**LEGEND:**

- ① 10mm HEAT STRENGTHENED GLASS (OUTER)
- ② 12mm HEAT STRENGTHENED GLASS (INNER)
- ③ 12mm HEAT STRENGTHENED GLASS (INTER)
- ④ 12mm HEAT STRENGTHENED GLASS (OUTER)
- ⑤ 12mm HEAT STRENGTHENED GLASS (INNER)
- ⑥ 12mm HEAT STRENGTHENED GLASS (INTER)
- ⑦ 12mm HEAT STRENGTHENED GLASS (OUTER)
- ⑧ 12mm HEAT STRENGTHENED GLASS (INNER)
- ⑨ 12mm HEAT STRENGTHENED GLASS (INTER)
- ⑩ 12mm HEAT STRENGTHENED GLASS (OUTER)
- ⑪ 12mm HEAT STRENGTHENED GLASS (INNER)
- ⑫ 12mm HEAT STRENGTHENED GLASS (INTER)
- ⑬ 12mm HEAT STRENGTHENED GLASS (OUTER)
- ⑭ 12mm HEAT STRENGTHENED GLASS (INNER)
- ⑮ 12mm HEAT STRENGTHENED GLASS (INTER)
- ⑯ 12mm HEAT STRENGTHENED GLASS (OUTER)
- ⑰ 12mm HEAT STRENGTHENED GLASS (INNER)
- ⑱ 12mm HEAT STRENGTHENED GLASS (INTER)
- ⑲ 12mm HEAT STRENGTHENED GLASS (OUTER)
- ⑳ 12mm HEAT STRENGTHENED GLASS (INNER)
- ㉑ 12mm HEAT STRENGTHENED GLASS (INTER)
- ㉒ 12mm HEAT STRENGTHENED GLASS (OUTER)
- ㉓ 12mm HEAT STRENGTHENED GLASS (INNER)
- ㉔ 12mm HEAT STRENGTHENED GLASS (INTER)
- ㉕ 12mm HEAT STRENGTHENED GLASS (OUTER)
- ㉖ 12mm HEAT STRENGTHENED GLASS (INNER)
- ㉗ 12mm HEAT STRENGTHENED GLASS (INTER)
- ㉘ 12mm HEAT STRENGTHENED GLASS (OUTER)
- ㉙ 12mm HEAT STRENGTHENED GLASS (INNER)
- ㉚ 12mm HEAT STRENGTHENED GLASS (INTER)
- ㉛ 12mm HEAT STRENGTHENED GLASS (OUTER)
- ㉜ 12mm HEAT STRENGTHENED GLASS (INNER)
- ㉝ 12mm HEAT STRENGTHENED GLASS (INTER)
- ㉞ 12mm HEAT STRENGTHENED GLASS (OUTER)
- ㉟ 12mm HEAT STRENGTHENED GLASS (INNER)
- ㊱ 12mm HEAT STRENGTHENED GLASS (INTER)
- ㊲ 12mm HEAT STRENGTHENED GLASS (OUTER)
- ㊳ 12mm HEAT STRENGTHENED GLASS (INNER)
- ㊴ 12mm HEAT STRENGTHENED GLASS (INTER)
- ㊵ 12mm HEAT STRENGTHENED GLASS (OUTER)
- ㊶ 12mm HEAT STRENGTHENED GLASS (INNER)
- ㊷ 12mm HEAT STRENGTHENED GLASS (INTER)
- ㊸ 12mm HEAT STRENGTHENED GLASS (OUTER)
- ㊹ 12mm HEAT STRENGTHENED GLASS (INNER)
- ㊺ 12mm HEAT STRENGTHENED GLASS (INTER)
- ㊻ 12mm HEAT STRENGTHENED GLASS (OUTER)
- ㊼ 12mm HEAT STRENGTHENED GLASS (INNER)
- ㊽ 12mm HEAT STRENGTHENED GLASS (INTER)
- ㊾ 12mm HEAT STRENGTHENED GLASS (OUTER)
- ㊿ 12mm HEAT STRENGTHENED GLASS (INNER)

**FLOOR LEVEL (S.F.L.)**

FLOOR	LEVEL
ROOF	+210.00
26/F	+206.70
25/F	+203.40

**CLIENT :** SHIMAO GROUP HOLDINGS LIMITED

**ARCHITECT :** WONG TUNG & PARTNERS LIMITED

**MAIN CONTRACTOR :** 德興建築有限公司  
HP HING CONSTRUCTION CO LTD

**STRUCTURAL ENGINEER :** CMA C W WONG & ASSOCIATES LTD  
美志明建築工程師有限公司

**FAÇADE CONSULTANT :** MENHARDT

**DATE :** 05-OCT-21  
**SCALE :** 1:60 (A1)

**PROJECT :** PROPOSED RESIDENTIAL DEVELOPMENT AT N.K.I.L. 6542 YIN PING ROAD KOWLOON

**TITLE :** PART ELEVATION FOR CURTAIN WALL AT TOWER 3

**JOB NO. :** J-853

**DATE :** 05-OCT-21

**REVISION :**

NO.	DATE	REVISION	BY

**NOTES :**

- ALL DIMENSIONS ARE IN MM.
- ALL DIMENSIONS ARE MEASURED FROM OUTSIDE.
- ALL DIMENSIONS AND BE FINISHED ON SITE BEFORE FABRICATION.

**LEGEND :**

- ① DETAIL MARK NO.
- ② FINISHED FLOOR LEVEL
- ③ S.F.L. - STRUCTURAL FLOOR LEVEL
- ④ REVERSED DETAIL

**UNITED STATES OF AMERICA**

**美特鋁質有限公司**  
M.T. Aluminium Technology Ltd.  
610 Chee Kwee Ling Road, Kowloon  
Tel: 23489211-4 Fax: (852) 27277665  
DWC NO. : 1853-SD-CW-4306