

工程指示 / 要求簡箋(E.I.)

工程指示編號：EI 4374 /22 修改版次：
 工程編號：J853 工程名稱：延坪道住宅項目
 工程項目：欄河項目開模
 收件人：Maggie Lot 發件人：Joe Chan 日期：14/2/2022

要求提供 / 確認 事項：

- () 初步鋁料 B.M. () 加工折圖，然後生產 () 尺寸表
- () 正式鋁料 B.M. () 技術上資料 / 指示 () 報價
- () 配件 B.M. () 樣辦或貨品說明書 () 分判合約
- () 其他：_____

內容：

請依附件資料，繪製模圖，共 22 款。
 (附 CAD 檔 + 組合圖)

請在 20/3/2022 前完成上列要求。

附有關圖紙 / 文件：

1 + 23 頁 + CAD 檔

以上項目為：

- 原合約工程包 原合約工程加 / 減賬 新工程報價

原因：-

分發東莞各部門：

- () 生產技術總監 連附件 () 技術部 連附件 () 生產部 連附件 () 機械設計部 連附件
- () 採購部 連附件 () 生產統籌部 連附件
- () 質檢部 連附件 () 會計部 連附件 () 報關組 連附件 () 其他 _____ 連附件

分發香港各部門：

- () 行政部 連附件 () 會計部 連附件 () 統籌部 連附件 () 工程部地盤科文 連附件
- () 採購部 連附件 () QS 部 連附件 () 維修部 連附件 () 其他 _____ 連附件

傳遞編號：

發件人簽署：

項目經理簽署：

①

CUSTOMER	CUSTOMER APPROVAL	CUST PART NO.	AL-GB-A1(0)
		SECTION NO.	X86215

玻璃欄河頂

a=0.1r
b=0.2r
c=0.3r
d=0.4r
e=0.5r

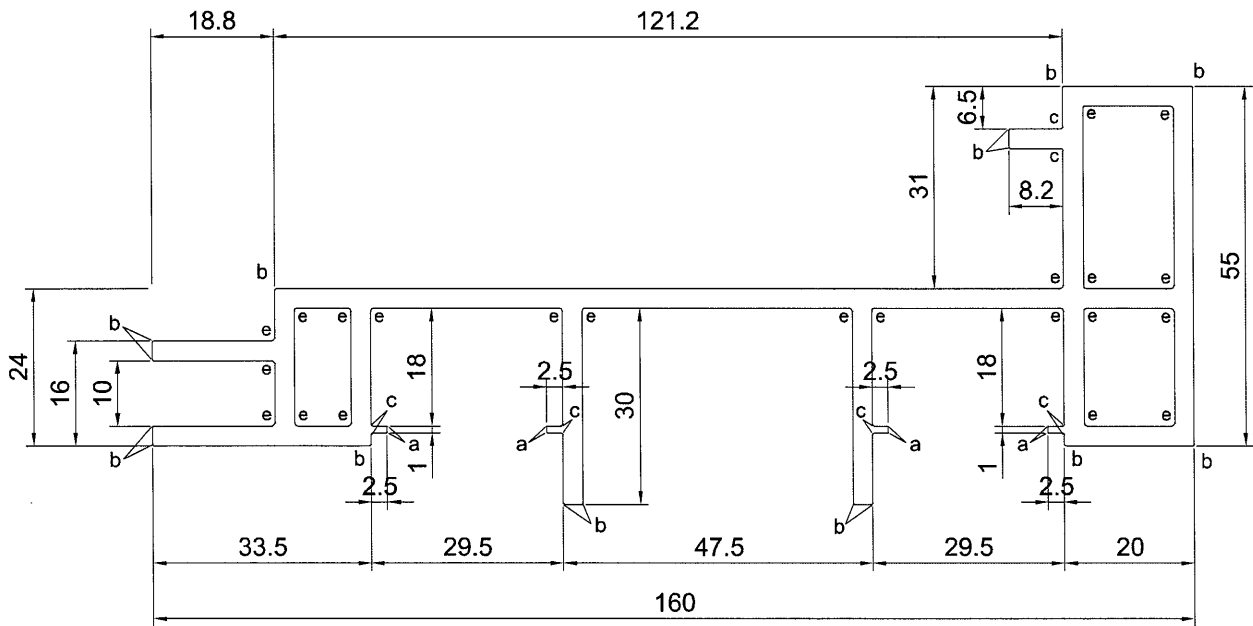

美特鋁質有限公司
承認圖面
日期 14/07/22

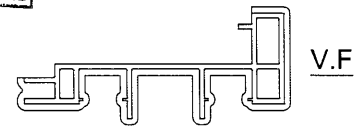

SCALE 1:4

SIGNATURE GRADEING	HIGH SIGNATURE GRADEING	C.C.DIA(MM)	169.19						
AREA (SQ MM)	1302.50	UNSPECIFIED THICKNESS	3.0	PERIMETER (MM)	660.94	STANDARD		SCALE	1:1
MASS (KG/M)	3.530	UNSPECIFIED CORNERS	-	SURFACE AREA	366.8	ALLOY	6063-T6	VERSION	-
COMPANY ISSUE			DRAWN	LHR	DATE	2022-01-05	APELLATION	PAGE OF	
			STANDARDIZATION		DATE				
			TO SIGN		DATE				
			AUDITING		DATE				
MARKER	MODIFY	FILE NO	SIGNATURE	DATE	APPROV		DATE		

美特鋁質有限公司
MIDI Aluminium Fabricator Ltd.

2

CUSTOMER	CUSTOMER APPROVAL	CUST PART NO.	AL-GB-A2(0)
		SECTION NO.	X86216

玻璃欄河底

a=0.1r
b=0.2r
c=0.3r
d=0.4r
e=0.5r

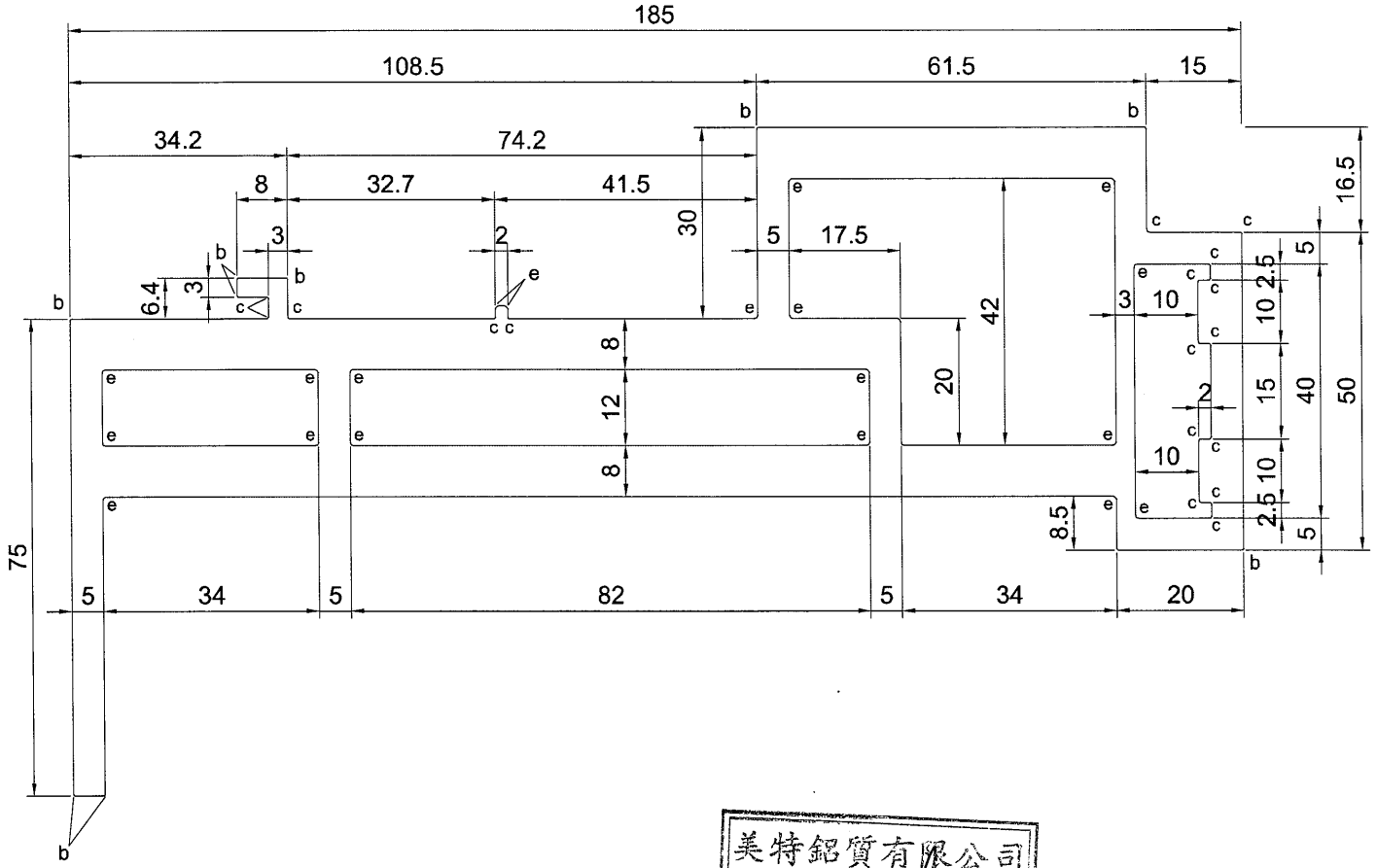

美特鋁質有限公司	
承認圖面	
日期	14/02/22

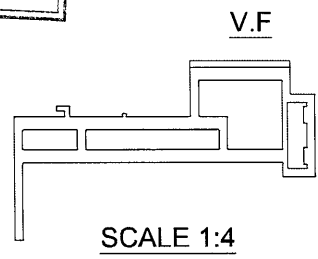

SIGNATURE GRADEING	HIGH SIGNATURE GRADEING	C.C.DIA(MM)	205.63						
AREA (SQ MM)	4026.79	UNSPECIFIED THICKNESS	5.0	PERIMETER (MM)	621.04	STANDARD		SCALE	1:1
MASS (KG/M)	10.913	UNSPECIFIED CORNERS	-	SURFACE AREA	61.5	ALLOY	6063-T6	VERSION	-
COMPANY ISSUE			DRAWN	LHR	DATE	2022-01-05	APELLATION	PAGE OF	
			STANDARDIZATION		DATE				
			TO SIGN		DATE				
			AUDITING		DATE				
MARKER	MODIFY	FILE NO	SIGNATURE	DATE	APPROV		DATE		

美特鋁質有限公司
MIDI Aluminium Fabricator Ltd.

3

CUSTOMER	CUSTOMER APPROVAL	CUST PART NO.	AL-GB-A3(0)
		SECTION NO.	X86217

玻璃欄河底鋁角

a=0.1r
b=0.2r
c=0.3r
d=0.4r
e=0.5r

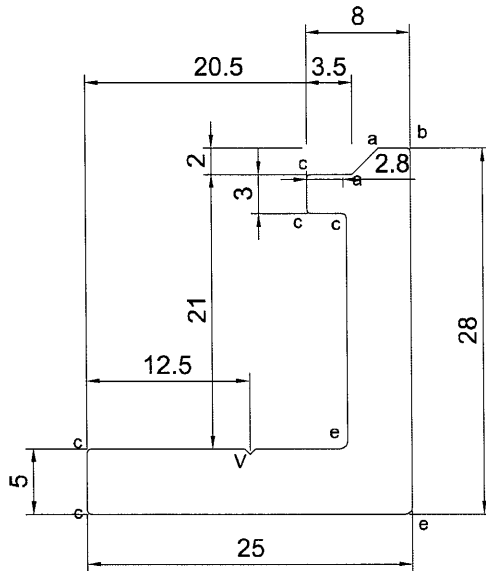

SCALE 2:1

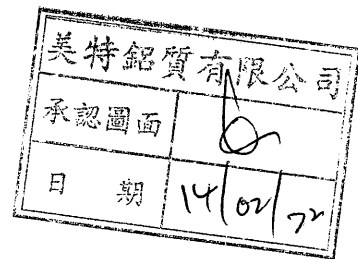

SIGNATURE GRADEING	HIGH SIGNATURE GRADEING	C.C.DIA(MM)	37.72						
AREA (SQ MM)	247.71	UNSPECIFIED THICKNESS	5.0	PERIMETER (MM)	111.18	STANDARD		SCALE	1:1
MASS (KG/M)	0.671	UNSPECIFIED CORNERS	-	SURFACE AREA	-	ALLOY	6063-T6	VERSION	-
COMPANY ISSUE			DRAWA	CJM	DATE	2022-01-18	APELLATION	PAGE OF	
			STANDA-RDIZATION		DATE				
			TO SIGN		DATE				
			AUDITING		DATE				
MARKER	MODIFY	FILE NO	SIGNATURE	DATE	APPROV		DATE		



④

CUSTOMER	CUSTOMER APPROVAL	CUST PART NO.	AL-GB-A4(0)
		SECTION NO.	X86218

a=0.1r
b=0.2r
c=0.3r
d=0.4r
e=0.5r

玻璃欄河特飾 (頂)

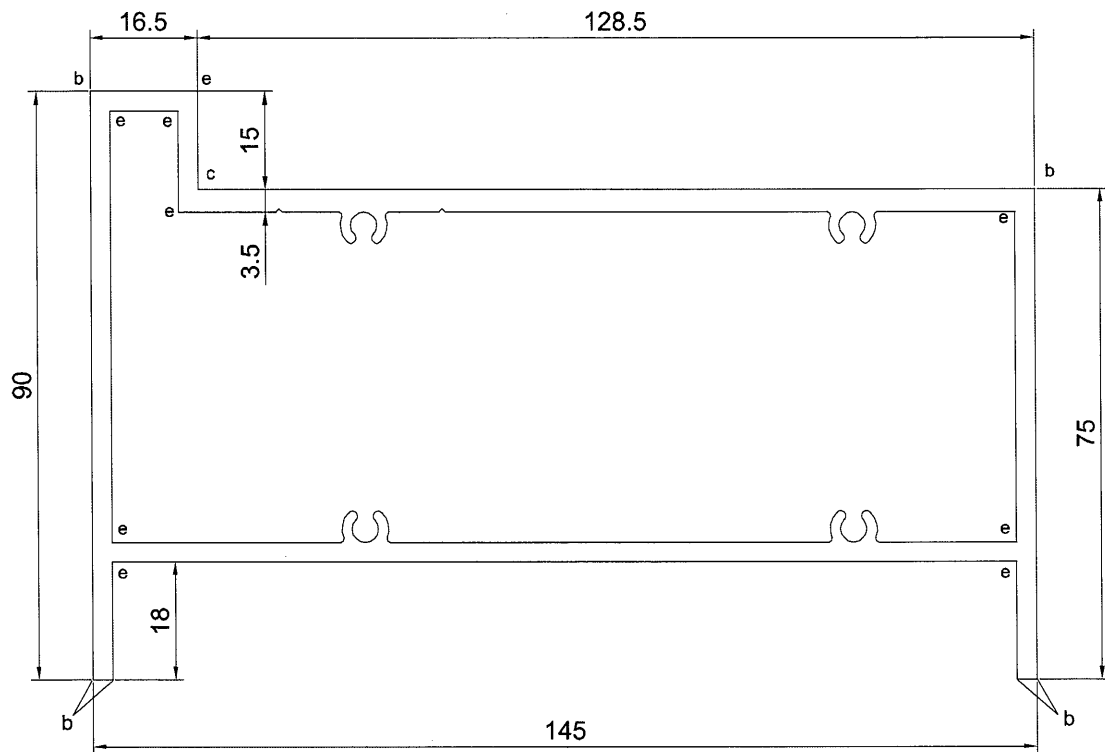

美特鋁質有限公司	
承認圖面	
日期	14/02/22

V.F

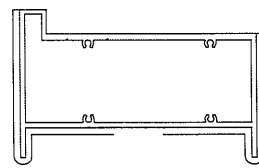

SCALE 1:4

SIGNATURE GRADEING	HIGH SIGNATURE GRADEING	C.C.DIA(MM)	170.66						
AREA (SQ MM)	1504.1	UNSPECIFIED THICKNESS	3.0	PERIMETER (MM)	506.00	STANDARD		SCALE	1:1
MASS (KG/M)	4.076	UNSPECIFIED CORNERS	-	SURFACE AREA	345.5	ALLOY	6063-T6	VERSION	-
COMPANY ISSUE			DRAWA	LHR	DATE	2022-01-05	APELLATION	PAGE OF	
			STANDARDIZATION		DATE				
			TO SIGN		DATE				
			AUDITING		DATE				
MARKER	MODIFY	FILE NO	SIGNATURE	DATE	APPROV	DATE			

5

CUSTOMER	CUSTOMER APPROVAL	CUST PART NO.	AL-GB-A5(0)
		SECTION NO.	X86219

a=0.1r
b=0.2r
c=0.3r
d=0.4r
e=0.5r

玻璃欄河特飾(底)

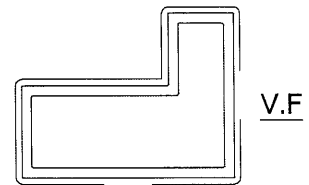
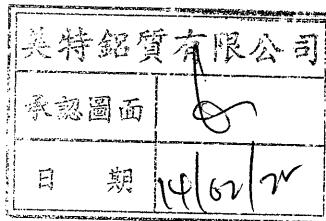
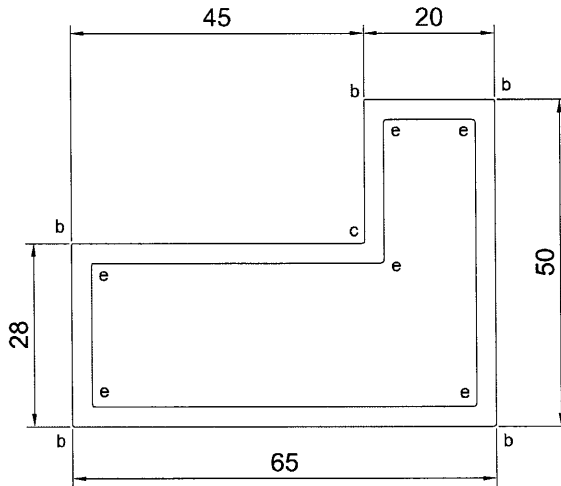

SCALE 1:2

SIGNATURE GRADEING	HIGH SIGNATURE GRADEING	C.C.DIA(MM)	82.0						
AREA (SQ MM)	654.2	UNSPECIFIED THICKNESS	3.0	PERIMETER (MM)	229.4	STANDARD		SCALE	1:1
MASS (KG/M)	1.773	UNSPECIFIED CORNERS	-	SURFACE AREA	229.4	ALLOY	6063-T6	VERSION	-
COMPANY ISSUE			DRAWN	CJM	DATE	2022-01-18	APELLATION	PAGE OF	
			STANDARDIZATION		DATE				
			TO SIGN		DATE				
			AUDITING		DATE				
MARKER	MODIFY	FILE NO	SIGNATURE	DATE	APPROV		DATE		

美特鋁質有限公司
MIDI Aluminium Fabricator Ltd.

6

CUSTOMER	CUSTOMER APPROVAL	CUST PART NO.	AL-UP-A6(0)
		SECTION NO.	X86220

柵格欄河頂

a=0.1r
b=0.2r
c=0.3r
d=0.4r
e=0.5r

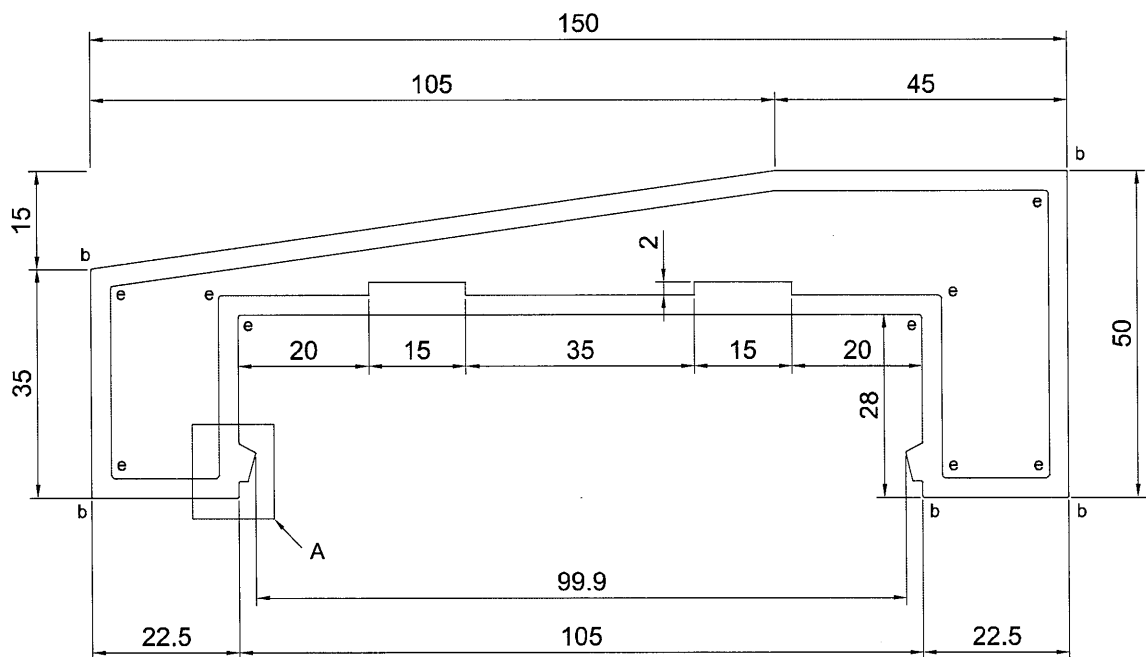
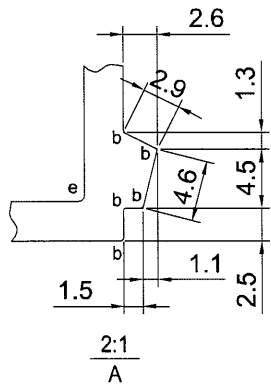

美特鋁質有限公司	
承認圖面	
日期	14/02/22

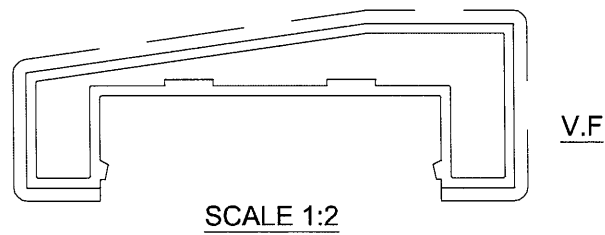

SIGNATURE GRADEING	HIGH SIGNATURE GRADEING	C.C.DIA(MM)	158.11						
AREA (SQ MM)	1372.53	UNSPECIFIED THICKNESS	3.0	PERIMETER (MM)	447.11	STANDARD		SCALE	1:1
MASS (KG/M)	3.720	UNSPECIFIED CORNERS	-	SURFACE AREA	281.0	ALLOY	6063-T6	VERSION	-
COMPANY ISSUE				DRAWN	LHR	DATE	2022-01-05	APELLATION	PAGE OF
				STANDARDIZATION		DATE			
				TO SIGN		DATE			
				AUDITING		DATE			
MARKER	MODIFY	FILE NO	SIGNATURE	DATE	APPROV	DATE			

美特鋁質有限公司
MIDI Aluminium Fabricator Ltd.

7

CUSTOMER	CUSTOMER APPROVAL	CUST PART NO.	AL-UP-A7(0)
		SECTION NO.	X86221

柵格欄河 (底)

a=0.1r
 b=0.2r
 c=0.3r
 d=0.4r
 e=0.5r

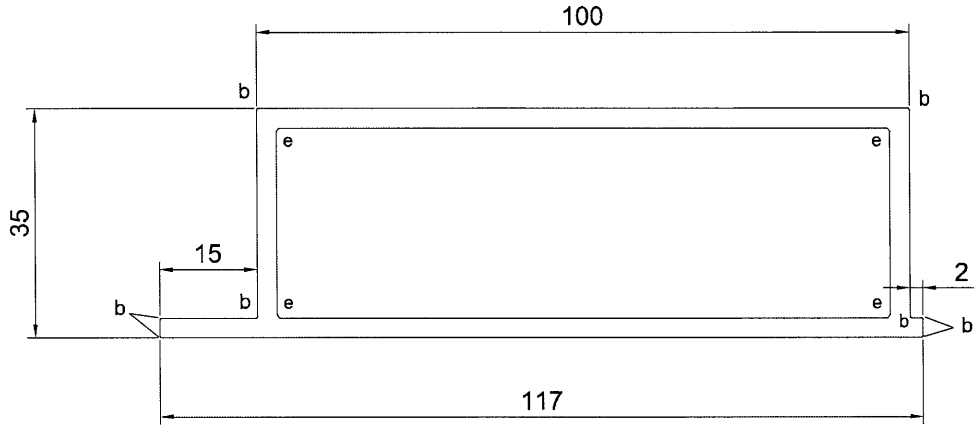

美特鋁質有限公司
 承認圖面
 日期 14/02/22

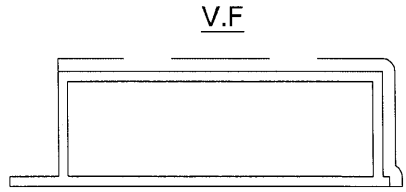

SCALE 1:2

SIGNATURE GRADEING	HIGH SIGNATURE GRADEING	C.C.DIA(MM)	120.40						
AREA (SQ MM)	825.16	UNSPECIFIED THICKNESS	3.0	PERIMETER (MM)	303.31	STANDARD		SCALE	1:1
MASS (KG/M)	2.236	UNSPECIFIED CORNERS	-	SURFACE AREA	137.0	ALLOY	6063-T6	VERSION	-
COMPANY ISSUE			DRAWN	LHR	DATE	2022-01-05	APELLATION	PAGE OF	
			STANDARDIZATION		DATE				
			TO SIGN		DATE				
			AUDITING		DATE				
MARKER	MODIFY	FILE NO	SIGNATURE	DATE	APPROV				

美特鋁質有限公司
 MIDI Aluminium Fabricator Ltd.

8

CUSTOMER	CUSTOMER APPROVAL	CUST PART NO.	AL-UP-A8(0)
		SECTION NO.	X86222

a=0.1r
b=0.2r
c=0.3r
d=0.4r
e=0.5r

柵格欄河主橫 (底)

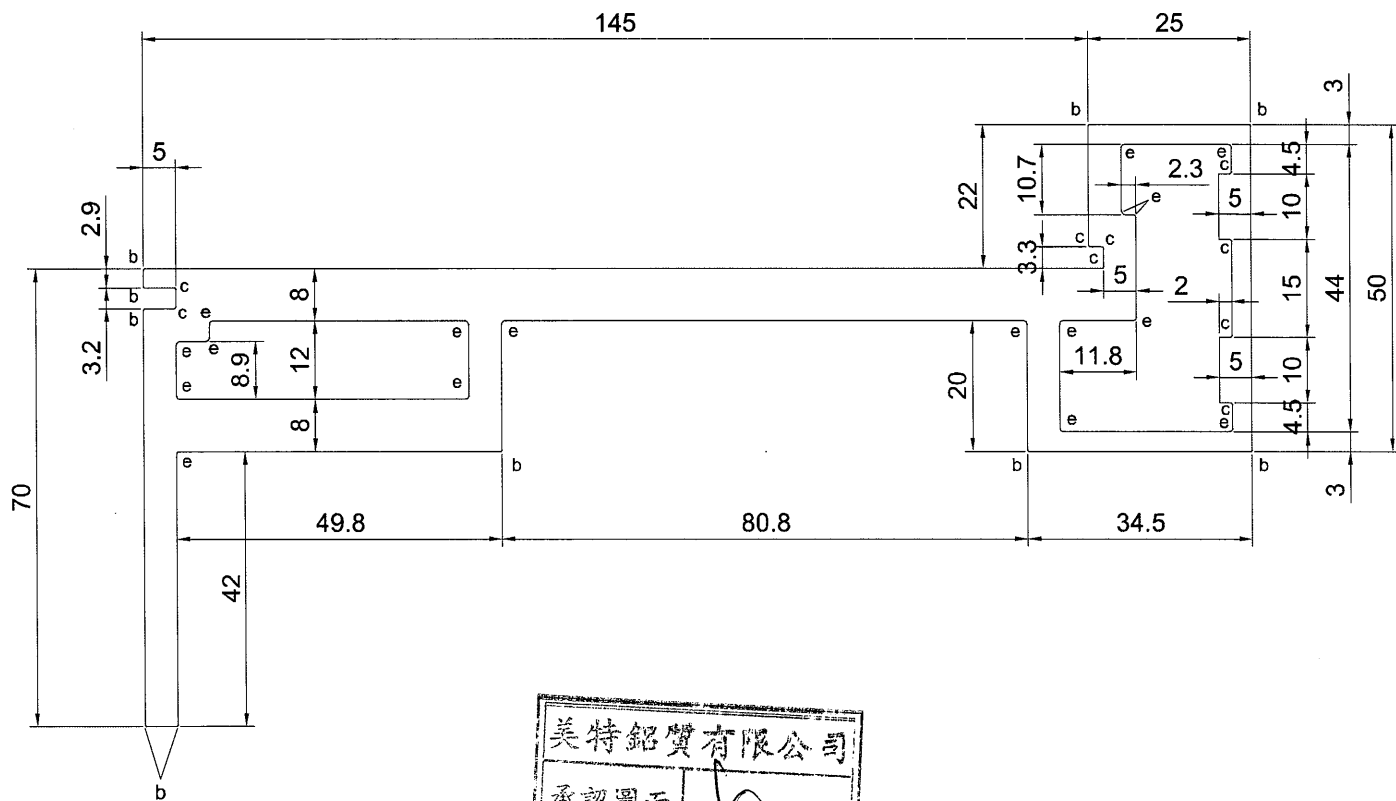

美特鋁質有限公司
承認圖面
日期 1/10/22

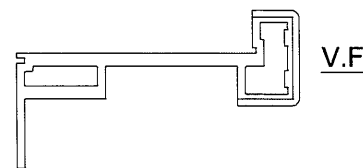

SCALE 1:4

SIGNATURE GRADEING	HIGH SIGNATURE GRADEING	C.C.DIA(MM)	199.11						
AREA (SQ MM)	2528.54	UNSPECIFIED THICKNESS	5.0	PERIMETER (MM)	576.59	STANDARD		SCALE	1:1
MASS (KG/M)	6.852	UNSPECIFIED CORNERS	-	SURFACE AREA	109.5	ALLOY	6063-T6	VERSION	-
COMPANY ISSUE				DRAWN	LHR	DATE	2022-01-05	APELLATION	PAGE OF
				STANDARDIZATION		DATE			
				TO SIGN		DATE			
				AUDITING		DATE			
MARKER	MODIFY	FILE NO	SIGNATURE	DATE	APPROV	DATE			

美特鋁質有限公司
MIDI Aluminium Fabricator Ltd.

9

CUSTOMER	CUSTOMER APPROVAL	CUST PART NO.	AL-UP-A9(0)
		SECTION NO.	X86223

a=0.1r
b=0.2r
c=0.3r
d=0.4r
e=0.5r

柵格欄河特飾 (頂)

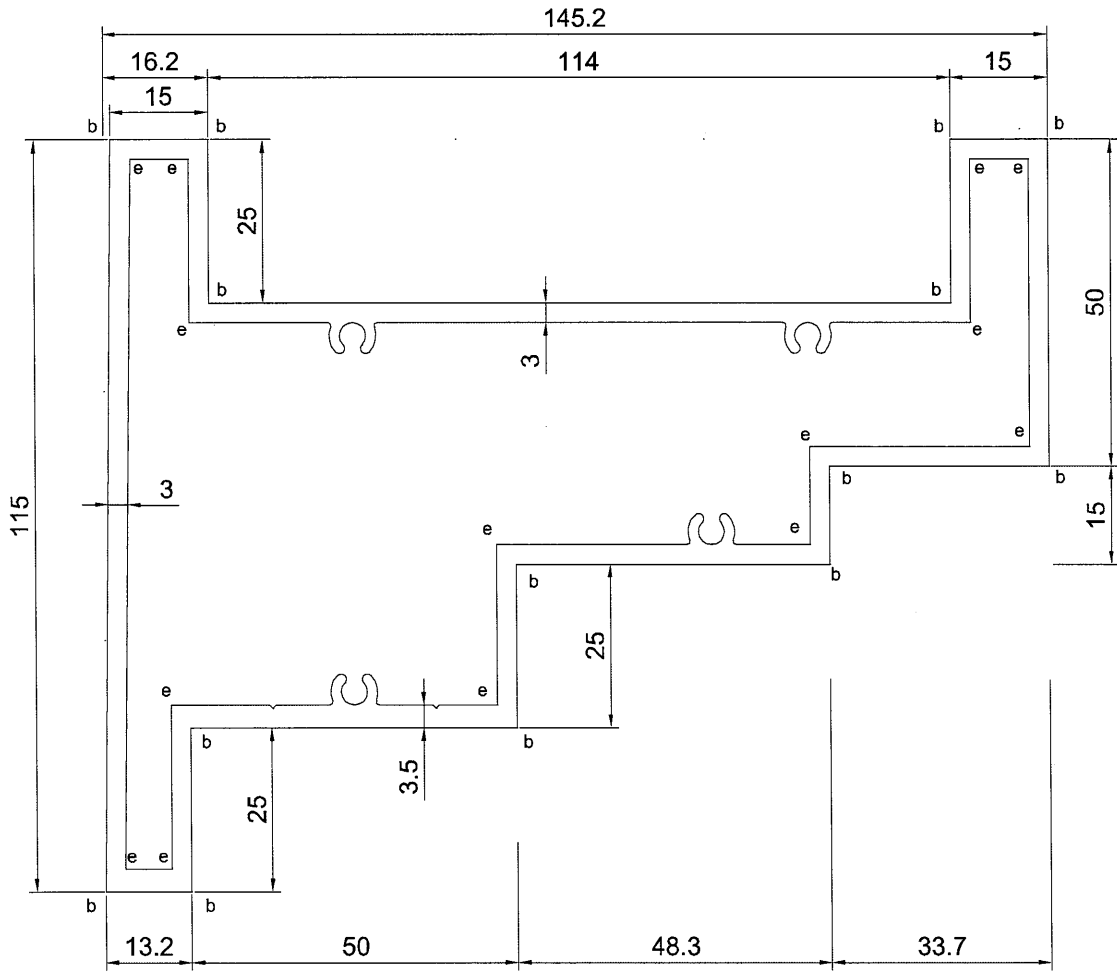

美特鋁質有限公司	
承認圖面	
日期	14/02/22

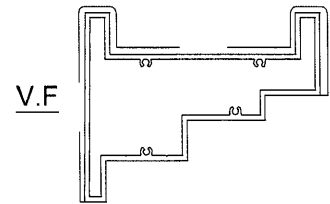

V.F

SCALE 1:4

SIGNATURE GRADEING	HIGH SIGNATURE GRADEING	C.C.DIA(MM)	185.19						
AREA (SQ MM)	1765.8	UNSPECIFIED THICKNESS	3.0	PERIMETER (MM)	569.16	STANDARD		SCALE	1:1
MASS (KG/M)	4.785	UNSPECIFIED CORNERS	-	SURFACE AREA	372.16	ALLOY	6063-T6	VERSION	-
COMPANY ISSUE			DRAWA	CJM	DATE	2022-01-18	APELLATION	PAGE OF	
			STANDA-RDIZATION		DATE				
			TO SIGN		DATE				
			AUDITING		DATE				
MARKER	MODIFY	FILE NO	SIGNATURE	DATE	APPROV	DATE			

美特鋁質有限公司
MIDI Aluminium Fabricator Ltd.

10

CUSTOMER	CUSTOMER APPROVAL	CUST PART NO.	AL-UP-A10(0)
		SECTION NO.	X86224

欄河柵格

$a=0.1r$
 $b=0.2r$
 $c=0.3r$
 $d=0.4r$
 $e=0.5r$

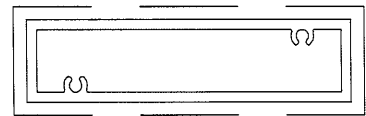
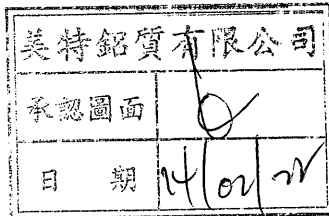
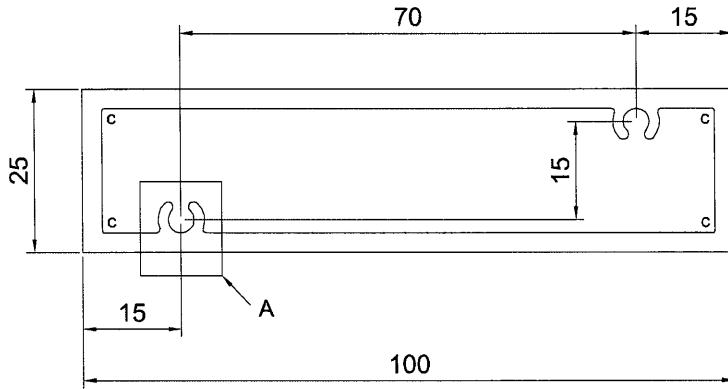
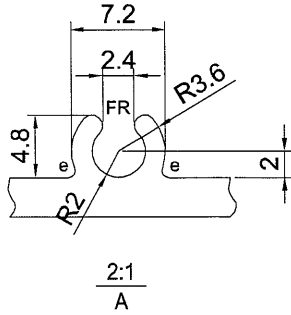

V.F

SCALE 1:2

SIGNATURE GRADEING	HIGH SIGNATURE GRADEING	C.C.DIA(MM)	103.08							
AREA (SQ MM)	747.24	UNSPECIFIED THICKNESS	3.0	PERIMETER (MM)	250.00	STANDARD		SCALE	1:1	
MASS (KG/M)	2.025	UNSPECIFIED CORNERS	-	SURFACE AREA	250.0	ALLOY	6063-T6	VERSION	-	
COMPANY ISSUE			DRAWN	LHR	DATE	2022-01-05	APELLATION	PAGE OF		
			STANDARDIZATION		DATE		 美特鋁質有限公司 MIDI Aluminium Fabricator Ltd.			
			TO SIGN		DATE					
			AUDITING		DATE					
MARKER	MODIFY	FILE NO	SIGNATURE	DATE	APPROV		DATE			

11

CUSTOMER	CUSTOMER APPROVAL	CUST PART NO.	AL-GB-A11(0)
		SECTION NO.	X86225

玻璃欄河邊企收口疋 (1)

a=0.1r
b=0.2r
c=0.3r
d=0.4r
e=0.5r

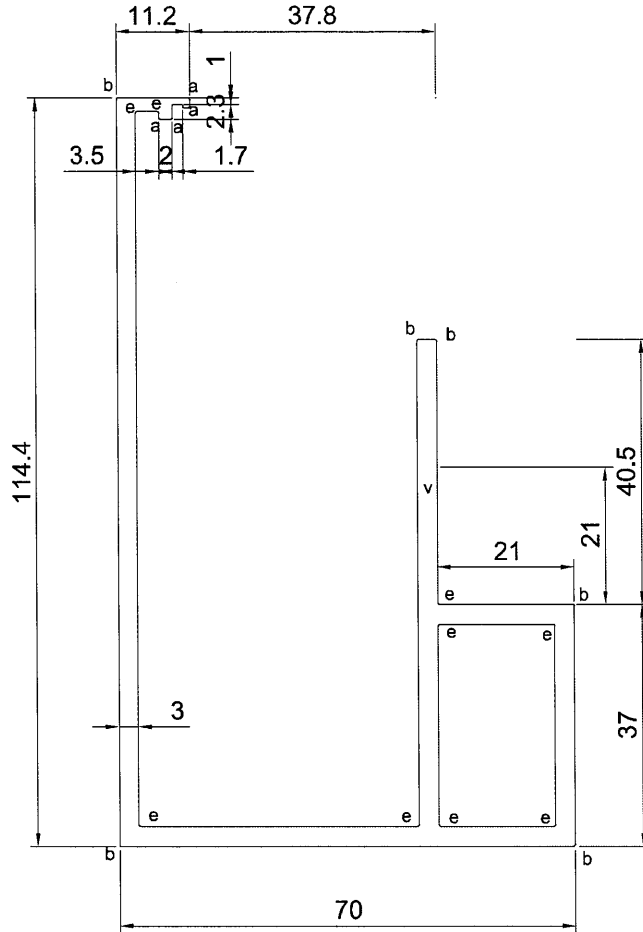

美特鋁質有限公司	
承認圖面	
日期	14/01/22

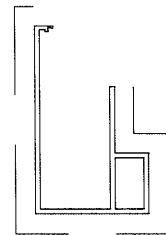

V.F

SCALE 1:4

SIGNATURE GRADEING	HIGH SIGNATURE GRADEING	C.C.DIA(MM)	133.93						
AREA (SQ MM)	940.6	UNSPECIFIED THICKNESS	3.0	PERIMETER (MM)	536.15	STANDARD		SCALE	1:1
MASS (KG/M)	2.545	UNSPECIFIED CORNERS	-	SURFACE AREA	221.51	ALLOY	6063-T5	VERSION	-
COMPANY ISSUE			DRAWN	CJM	DATE	2022-01-18	APELLATION	PAGE OF	
			STANDARDIZATION		DATE		美特鋁質有限公司 MIDI Aluminium Fabricator Ltd.		
			TO SIGN		DATE				
			AUDITING		DATE				
MARKER	MODIFY	FILE NO	SIGNATURE	DATE	APPROV	DATE			

CUSTOMER	CUSTOMER APPROVAL	CUST PART NO.	AL-GB-A12(0)
		SECTION NO.	X86226

a=0.1r
b=0.2r
c=0.3r
d=0.4r
e=0.5r

玻璃欄河邊企收口圖 (2)

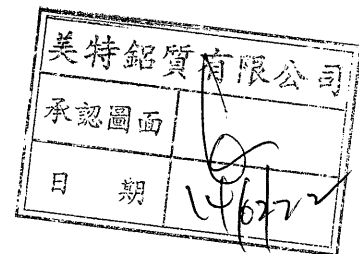
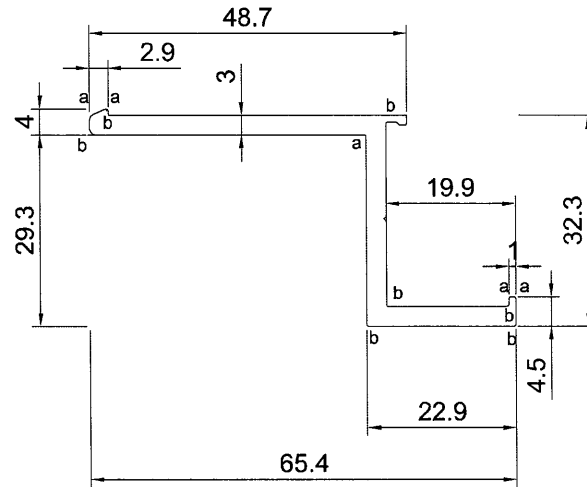

SIGNATURE GRADEING	HIGH SIGNATURE GRADEING	C.C.DIA(MM)	73.22						
AREA (SQ MM)	290.5	UNSPECIFIED THICKNESS	3.0	PERIMETER (MM)	205.1	STANDARD		SCALE	1:1
MASS (KG/M)	0.787	UNSPECIFIED CORNERS	-	SURFACE AREA	-	ALLOY	6063-T5	VERSION	-
COMPANY ISSUE			DRAWA	CJM	DATE	2022-01-18	APELLATION	PAGE OF	
			STANDA-RDIZATION		DATE		 美特鋁質有限公司 MIDI Aluminium Fabricator Ltd.		
			TO SIGN		DATE				
			AUDITING		DATE				
MARKER	MODIFY	FILE NO	SIGNATURE	DATE	APPROV	DATE			

13

CUSTOMER	CUSTOMER APPROVAL	CUST PART NO.	AL-GB-A13(0)
		SECTION NO.	X86227

玻璃欄河主企收口疋 (4)

a=0.1r
b=0.2r
c=0.3r
d=0.4r
e=0.5r

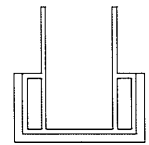
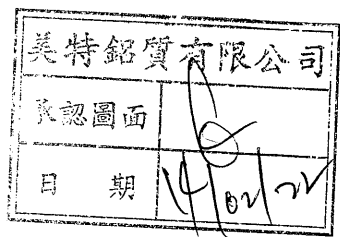
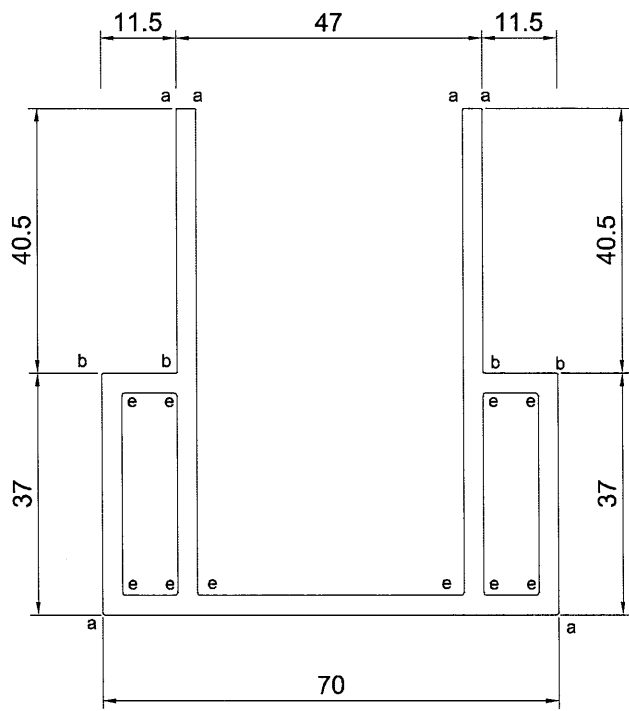

V.F

SCALE 1:4

SIGNATURE GRADEING	HIGH SIGNATURE GRADEING	C.C.DIA(MM)	97.97						
AREA (SQ MM)	912.58	UNSPECIFIED THICKNESS	3.0	PERIMETER (MM)	598.98	STANDARD		SCALE	1:1
MASS (KG/M)	2.473	UNSPECIFIED CORNERS	-	SURFACE AREA	143.97	ALLOY	6063-T5	VERSION	-
COMPANY ISSUE			DRAWA	CJM	DATE	2022-01-18	APELLATION	PAGE OF	
			STANDA-RDIZATION		DATE		美特鋁質有限公司 MIDI Aluminium Fabricator Ltd.		
			TO SIGN		DATE				
			AUDITING		DATE				
MARKER	MODIFY	FILE NO	SIGNATURE	DATE	APPROV	DATE			

14

CUSTOMER	CUSTOMER APPROVAL	CUST PART NO.	AL-GB-A14(0)
		SECTION NO.	X86228

玻璃欄河主企收口雷 (5)

a=0.1r
b=0.2r
c=0.3r
d=0.4r
e=0.5r

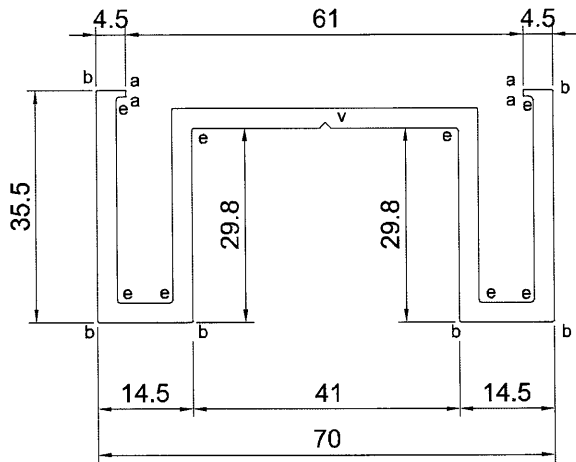

美特鋁質有限公司	
承認圖面	
日期	14/02/22

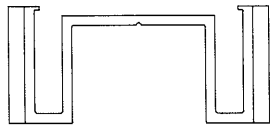

V.F

SCALE 1:2

SIGNATURE GRADEING	HIGH SIGNATURE GRADEING	C.C.DIA(MM)	78.48						
AREA (SQ MM)	586.13	UNSPECIFIED THICKNESS	3.0	PERIMETER (MM)	399.12	STANDARD		SCALE	1:1
MASS (KG/M)	1.588	UNSPECIFIED CORNERS	-	SURFACE AREA	71.45	ALLOY	6063-T5	VERSION	-
COMPANY ISSUE		DRAWN	CJM	DATE	2022-01-18	APELLATION		PAGE OF	
		STANDARDIZATION		DATE		 美特鋁質有限公司 MIDI Aluminium Fabricator Ltd.			
		TO SIGN		DATE					
		AUDITING		DATE					
MARKER	MODIFY	FILE NO	SIGNATURE	DATE	APPROV				

15

CUSTOMER	CUSTOMER APPROVAL	CUST PART NO.	AL-GB-A15(0)
		SECTION NO.	X86229

a=0.1r
b=0.2r
c=0.3r
d=0.4r
e=0.5r

玻璃欄河頂收口釘

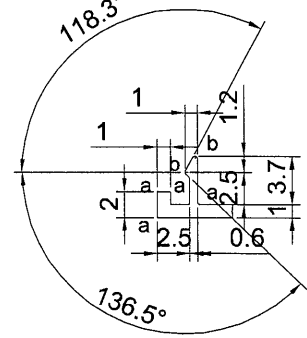

A
2:1

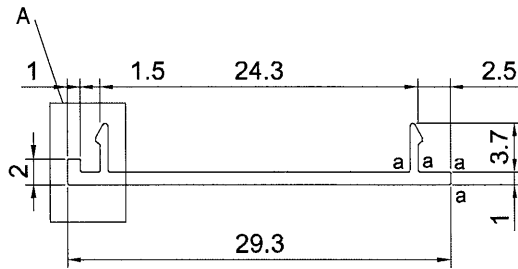

SCALE 2:1

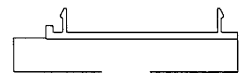
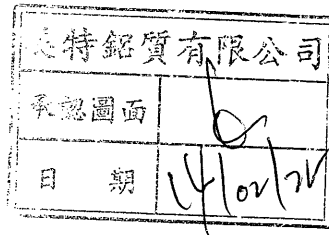

V.F

SCALE 1:1

SIGNATURE GRADEING	HIGH SIGNATURE GRADEING	C.C.DIA(MM)	58.79						
AREA (SQ MM)	140.34	UNSPECIFIED THICKNESS	1.0	PERIMETER (MM)	153.86	STANDARD		SCALE	1:1
MASS (KG/M)	0.38	UNSPECIFIED CORNERS	-	SURFACE AREA	29.3	ALLOY	6063-T5	VERSION	-
COMPANY ISSUE			DRAWA	CJM	DATE	2022-01-18	APELLATION	PAGE OF	
			STANDA-RDIZATION		DATE				
			TO SIGN		DATE				
			AUDITING		DATE				
MARKER	MODIFY	FILE NO	SIGNATURE	DATE	APPROV	DATE			

美特鋁質有限公司
MIDI Aluminium Fabricator Ltd.

CUSTOMER	CUSTOMER APPROVAL	CUST PART NO.	AL-GB-A16(0)
		SECTION NO.	X86230

玻璃欄河室內收口釘 (底)

a=0.1r
b=0.2r
c=0.3r
d=0.4r
e=0.5r

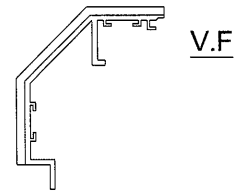
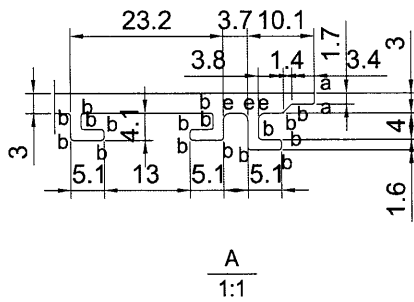
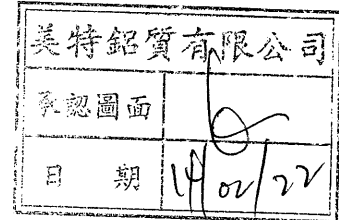
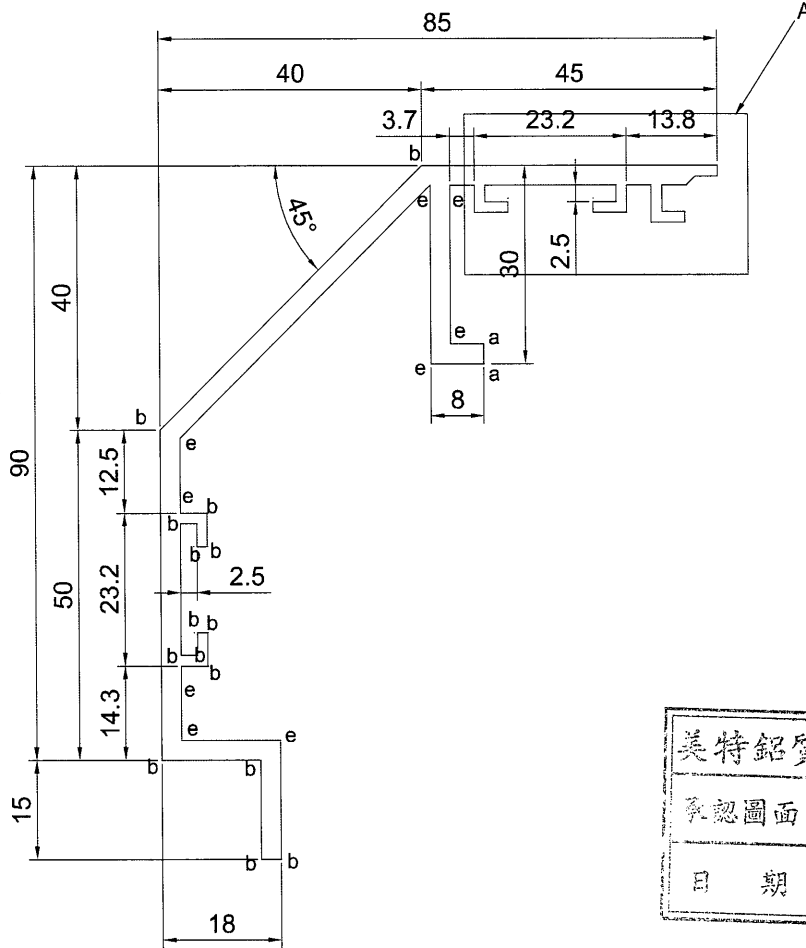

SCALE 1:4

SIGNATURE GRADEING	HIGH SIGNATURE GRADEING	C.C.DIA(MM)	126.17						
AREA (SQ MM)	690.9	UNSPECIFIED THICKNESS	3.0	PERIMETER (MM)	506.3	STANDARD		SCALE	1:1
MASS (KG/M)	1.872	UNSPECIFIED CORNERS	-	SURFACE AREA	151.52	ALLOY	6063-T5	VERSION	-
COMPANY ISSUE			DRAWN	CJM	DATE	2022-01-18	APELLATION	PAGE OF	
			STANDARDIZATION		DATE				
			TO SIGN		DATE				
			AUDITING		DATE				
MARKER	MODIFY	FILE NO	SIGNATURE	DATE	APPROV		DATE		



17

CUSTOMER	CUSTOMER APPROVAL	CUST PART NO.	AL-UP-A17(0)
		SECTION NO.	X86231

柵格欄河室內收口窗(底)

a=0.1r
b=0.2r
c=0.3r
d=0.4r
e=0.5r

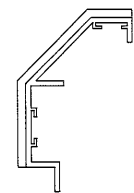
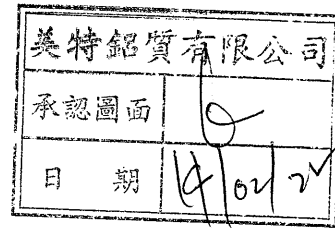
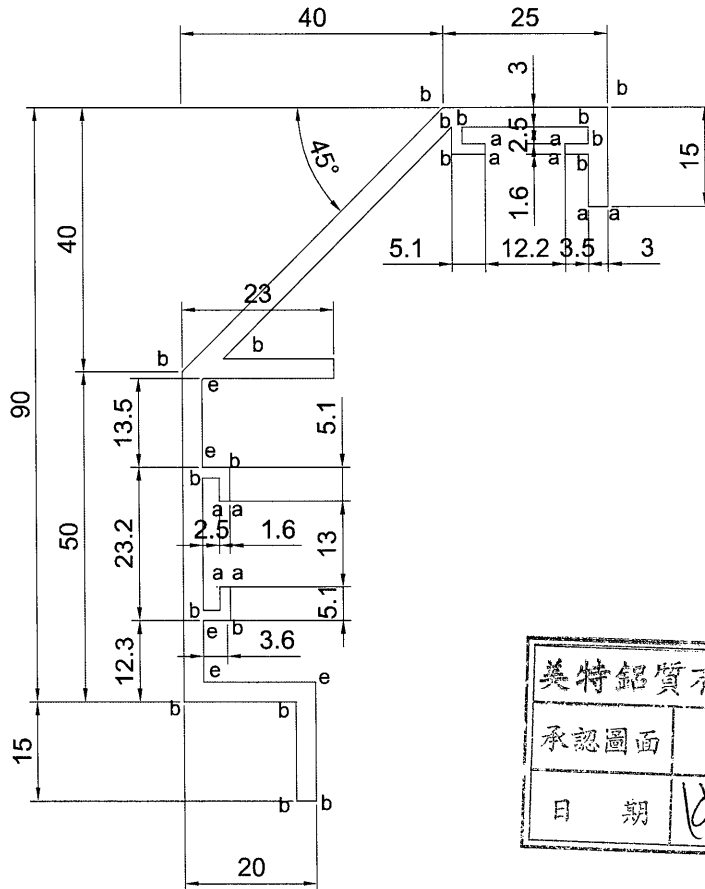

V.F

SCALE 1:4

SIGNATURE GRADEING	HIGH SIGNATURE GRADEING	C.C.DIA(MM)	115.45						
AREA (SQ MM)	616.1	UNSPECIFIED THICKNESS	3.0	PERIMETER (MM)	440.00	STANDARD		SCALE	1:1
MASS (KG/M)	1.670	UNSPECIFIED CORNERS	-	SURFACE AREA	131.56	ALLOY	6063-T5	VERSION	-
COMPANY ISSUE			DRAWA	CJM	DATE	2022-01-18	APELLATION	PAGE OF	
			STANDA-RDIZATION		DATE		 美特鋁質有限公司 MIDI Aluminium Fabricator Ltd.		
			TO SIGN		DATE				
			AUDITING		DATE				
MARKER	MODIFY	FILE NO	SIGNATURE	DATE	APPROV		DATE		

18

CUSTOMER	CUSTOMER APPROVAL	CUST PART NO.	AL-UP-A18(0)
		SECTION NO.	X86232

柵格欄河鋁板特飾

a=0.1r
 b=0.2r
 c=0.3r
 d=0.4r
 e=0.5r

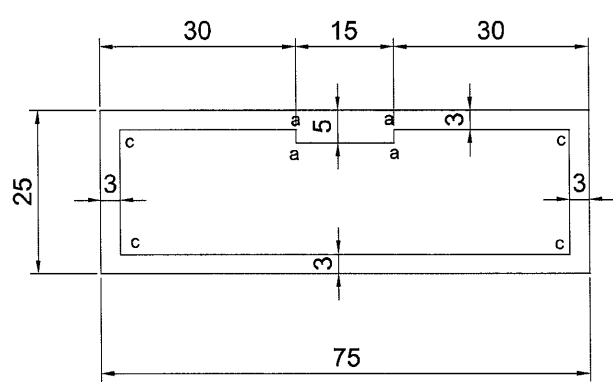

美特鋁質有限公司	
承認圖面	<i>[Signature]</i>
日期	11/02/22

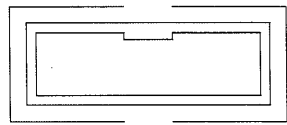

V.F

SCALE 1:2

SIGNATURE GRADEING	HIGH SIGNATURE GRADEING	C.C.DIA(MM)	79.05						
AREA (SQ MM)	574	UNSPECIFIED THICKNESS	3.0	PERIMETER (MM)	200	STANDARD		SCALE	1:1
MASS (KG/M)	1.609	UNSPECIFIED CORNERS	-	SURFACE AREA	200.0	ALLOY	6063-T5	VERSION	-
COMPANY ISSUE			DRAWN	CJM	DATE	2022-01-18	APELLATION	PAGE OF	
			STANDARDIZATION		DATE				
			TO SIGN		DATE				
			AUDITING		DATE				
MARKER	MODIFY	FILE NO	SIGNATURE	DATE	APPROV	DATE			

美特鋁質有限公司
 MIDl Aluminium Fabricator Ltd.

19

CUSTOMER	CUSTOMER APPROVAL	CUST PART NO.	AL-UP-A19(0)
		SECTION NO.	X86233

柵格欄河主企收口笛 (7)

a=0.1r
b=0.2r
c=0.3r
d=0.4r
e=0.5r

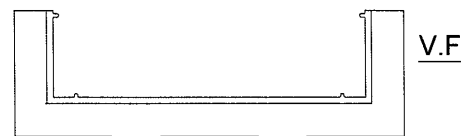
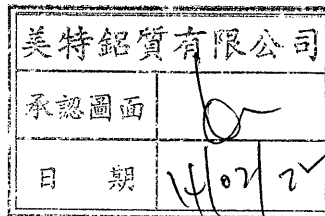
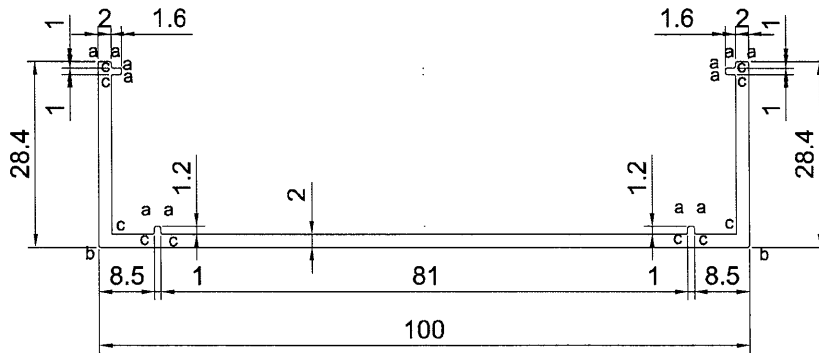

SCALE 1:2

SIGNATURE GRADEING	HIGH SIGNATURE GRADEING	C.C.DIA(MM)	103.81						
AREA (SQ MM)	311.14	UNSPECIFIED THICKNESS	2.0	PERIMETER (MM)	318.22	STANDARD		SCALE	1:1
MASS (KG/M)	0.843	UNSPECIFIED CORNERS	-	SURFACE AREA	156.8	ALLOY	6063-T5	VERSION	-
COMPANY ISSUE		DRAWN	CJM	DATE	2022-01-18	APELLATION		PAGE OF	
		STANDARDIZATION		DATE		美特鋁質有限公司 MIDI Aluminium Fabricator Ltd.			
		TO SIGN		DATE					
		AUDITING		DATE					
MARKER	MODIFY	FILE NO	SIGNATURE	DATE	APPROV				

21

CUSTOMER	CUSTOMER APPROVAL	CUST PART NO.	AL-GB-A21(0)
		SECTION NO.	X86235

a=0.1r
 b=0.2r
 c=0.3r
 d=0.4r
 e=0.5r

玻璃欄河邊企收口疋 (3)

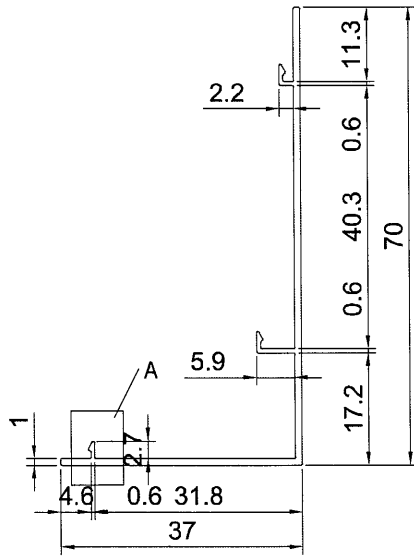
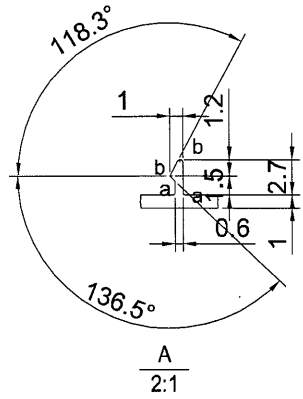

美特鋁質有限公司		
承認圖面	[Signature]	
日期	14	02/22

鋁質有限公司	
圖面	
期	

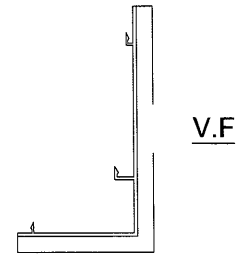

SCALE 1:2

SIGNATURE GRADEING	HIGH SIGNATURE GRADEING	C.C.DIA(MM)	79.17						
AREA (SQ MM)	116.1	UNSPECIFIED THICKNESS	1.6	PERIMETER (MM)	244.6	STANDARD		SCALE	1:1
MASS (KG/M)	0.315	UNSPECIFIED CORNERS	-	SURFACE AREA	108.6	ALLOY	6063-T5	VERSION	-
COMPANY ISSUE			DRAWA	CJM	DATE	2022-01-18	APELLATION	PAGE OF	
			STANDA-RDIZATION		DATE				
			TO SIGN		DATE				
			AUDITING		DATE				
MARKER	MODIFY	FILE NO	SIGNATURE	DATE	APPROV		DATE		

美特鋁質有限公司
 MIDI Aluminium Fabricator Ltd.

22

CUSTOMER	CUSTOMER APPROVAL	CUST PART NO.	AL-GB-A22(0)
		SECTION NO.	X86236

a=0.1r
 b=0.2r
 c=0.3r
 d=0.4r
 e=0.5r

玻璃欄河主企收口雷 (6)

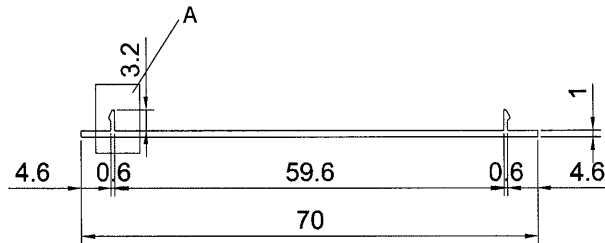
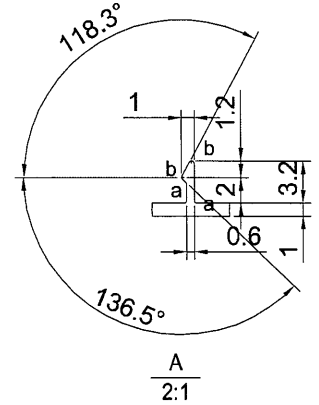

美特鋁質有限公司	
承認圖面	
日期	14/04/22



SCALE 1:2

SIGNATURE GRADEING	HIGH SIGNATURE GRADEING	C.C.DIA(MM)	69.97						
AREA (SQ MM)	74.146	UNSPECIFIED THICKNESS	1.0	PERIMETER (MM)	154.33	STANDARD		SCALE	1:1
MASS (KG/M)	0.201	UNSPECIFIED CORNERS	-	SURFACE AREA	70	ALLOY	6063-T5	VERSION	-
COMPANY ISSUE			DRAWA	CJM	DATE	2022-01-18	APELLATION	PAGE OF	
			STANDA-RDIZATION		DATE				
			TO SIGN		DATE				
			AUDITING		DATE				
MARKER	MODIFY	FILE NO	SIGNATURE	DATE	APPROV		DATE		

美特鋁質有限公司
MIDI Aluminium Fabricator Ltd.

