



工程指示 / 要求簡箋(E.I.)

工程指示編號：EI/ 37681 21

修改版次：

工程編號：J-853

工程名稱：大窩坪(廷坪路)

工程項目：幕牆項目開模

收件人：Maggie 姐

發件人：大明

日期：31/08/2021

要求提供 / 確認 事項：

- | | | |
|------------------------------------|-------------------------------------|-------------------------------|
| <input type="checkbox"/> 初步鋁料 B.M. | <input type="checkbox"/> 加工拆圖，然後生產 | <input type="checkbox"/> 尺寸表 |
| <input type="checkbox"/> 正式鋁料 B.M. | <input type="checkbox"/> 技術上資料 / 指示 | <input type="checkbox"/> 報 |
| <input type="checkbox"/> 配件 B.M. | <input type="checkbox"/> 樣辦或貨品說明書 | <input type="checkbox"/> 分判合約 |
| <input type="checkbox"/> 其他：_____ | | |

內容：

煩請 按圖紙開劃摸圖 X85971 ~ X86002 共 32 個

請在 10/09/2021 前完成上列要求。

附有關圖紙 / 文件：附 B.M 表 0 頁,圖紙 32 頁

以上項目為:

- 原合約工程包 原合約工程加 / 減賬 新工程報價

原因：-

分發東莞各部門：

- ()生產技術總監 連附件 ()技術部 連附件 ()生產部 連附件 ()機械設計部 連附件
 ()採購部 連附件 ()生產統籌部 連附件
 ()質檢部 連附件 ()會計部 連附件 ()報關組 連附件 ()其他 _____ 連附件

分發香港各部門：

- ()行政部 連附件 ()會計部 連附件 ()統籌部 連附件 ()工程部地盤科文 連附件
 ()採購部 連附件 ()QS 部 連附件 ()維修部 連附件 ()其他 _____ 連附件

傳遞編號：

發件人簽署：

項目經理簽署：

C.W 美特鋁業 (0)

CUSTOMER	CUSTOMER APPROVAL	CUST PART NO.	AL-CW-M4(0)
		SECTION NO.	X85974

- a=0.1r
- b=0.2r
- c=0.3r
- d=0.4r
- e=0.5r
- f=0.8r
- g=1.0r
- h=3.0r

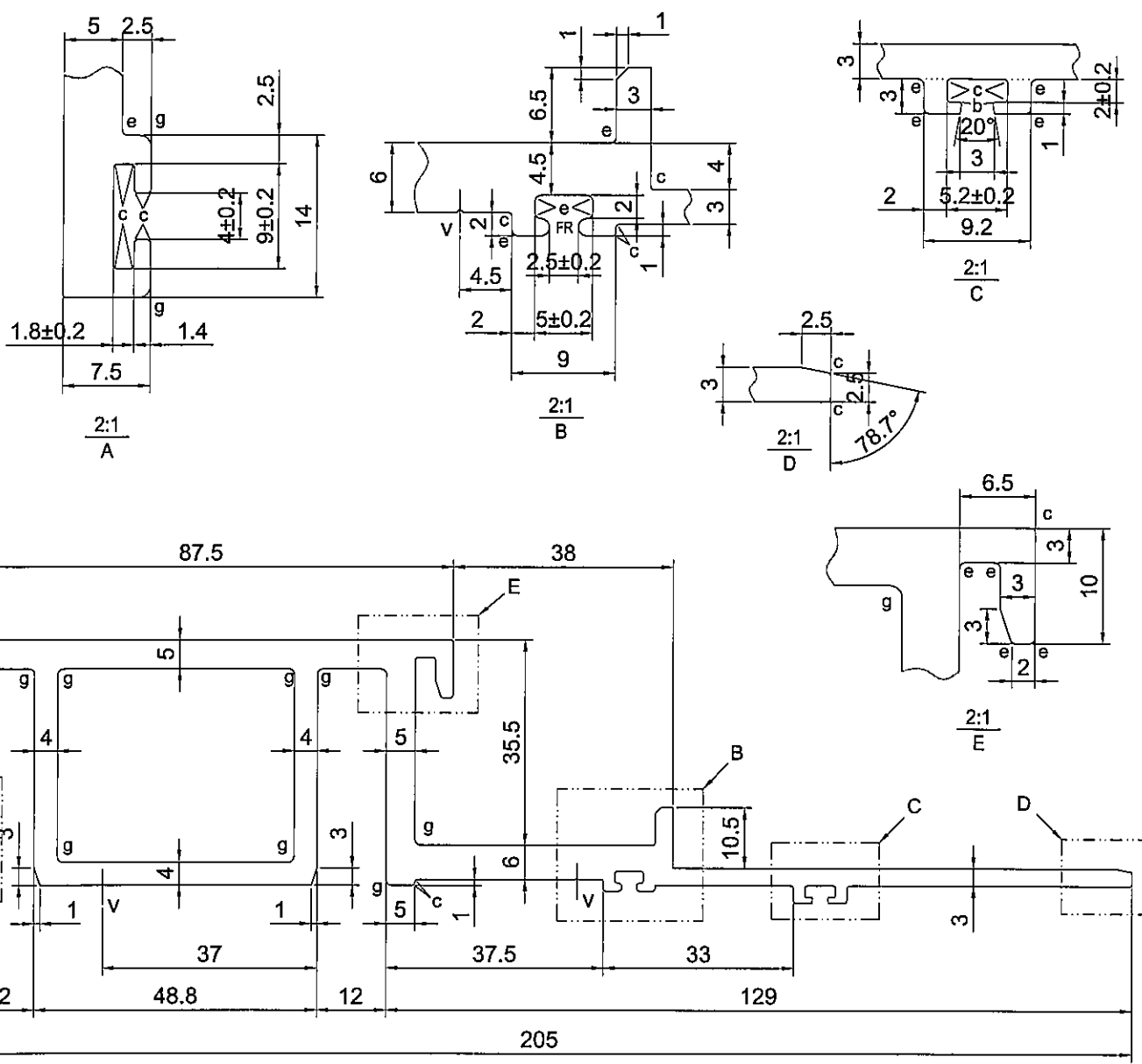

美特鋁業有限公司	
承認圖面	
日期	3/08/21

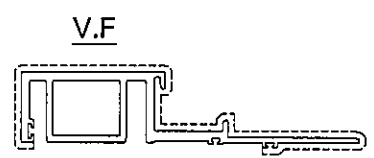

SCALE 1:4

SIGNATURE GRADEING	HIGH SIGNATURE GRADEING	C.C.DIA(MM)	209.36					
AREA (SQ MM)	1838.82	UNSPECIFIED THICKNESS	-	PERIMETER (MM)	725.28	STANDARD	SCALE	1:1
MASS (KG/M)	4.983	UNSPECIFIED CORNERS	-	SURFACE AREA	408.34	ALLOY	6063-T6	VERSION
COMPANY ISSUE			DRAWN	LHR	DATE	2021-07-23	APPELLATION	PAGE OF
			STANDARDIZATION		DATE			
			TO SIGN		DATE			
			AUDITING		DATE			
MARKER	MODIFY	FILE NO	SIGNATURE	DATE	APPROV			

美特鋁業有限公司
MIDI Aluminium Fabricator Ltd

C.W 轉角 主色 10

CUSTOMER	CUSTOMER APPROVAL	CUST PART NO.	AL-CW-M7(0)
		SECTION NO.	X85977

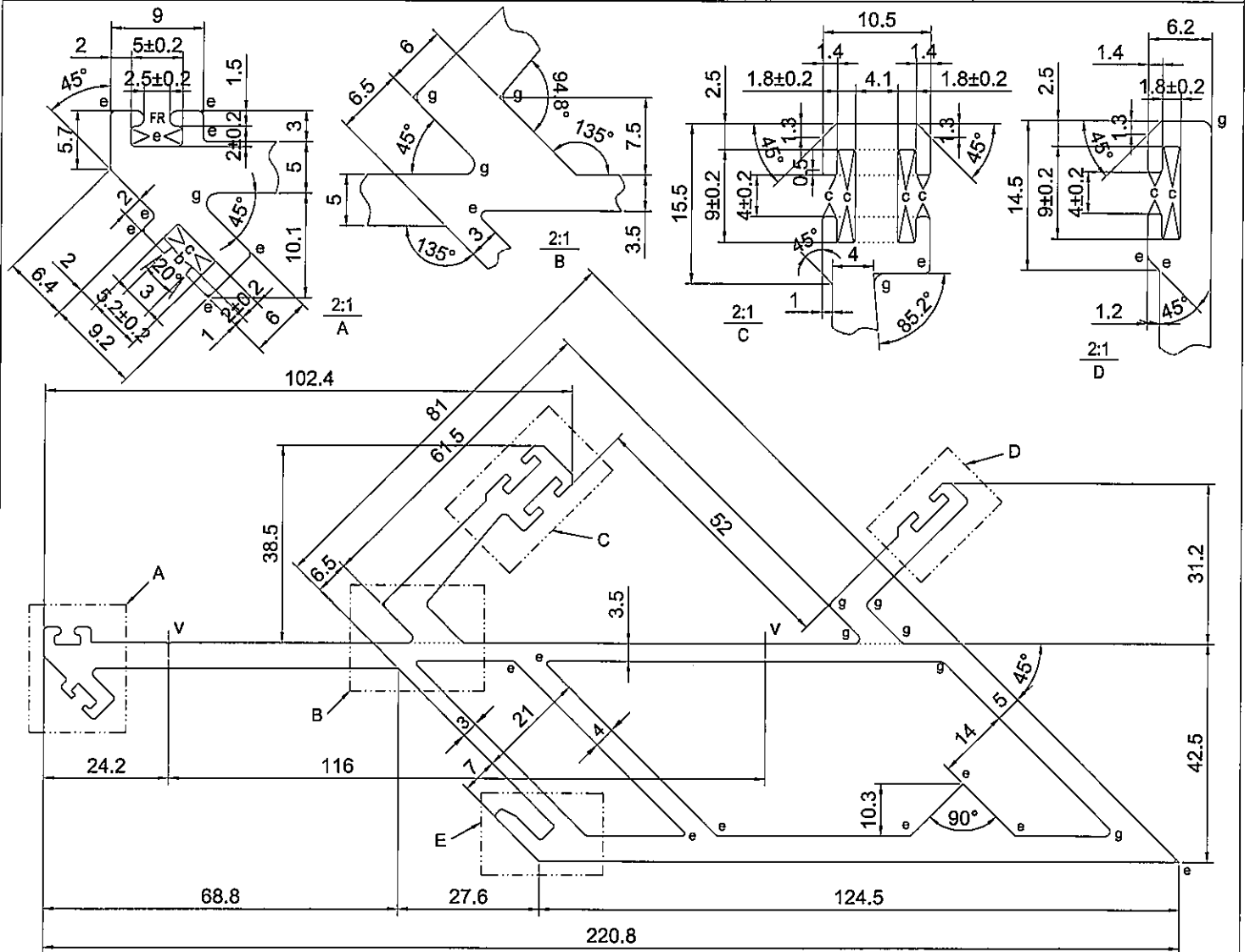

美特鋁質有限公司	
承認圖面	
日期	31/08/21

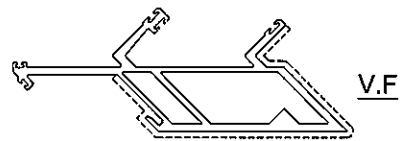
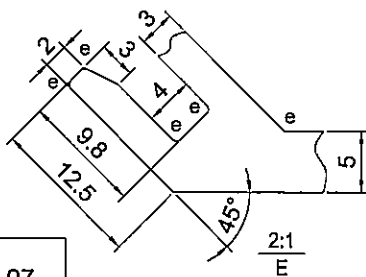

- a=0.1r
- b=0.2r
- c=0.3r
- d=0.4r
- e=0.5r
- f=0.8r
- g=1.0r
- h=3.0r

SCALE 1:4

SIGNATURE GRADEING	HIGH SIGNATURE GRADEING	C.C.DIA(MM)	241.97	AREA (SQ MM)	2630.43	UNSPECIFIED THICKNESS	5.0	PERIMETER (MM)	781.15	STANDARD		SCALE	1:1
MASS (KG/M)	7.128	UNSPECIFIED CORNERS	-	SURFACE AREA	305.0	ALLOY	6063-T6	VERSION	A				
COMPANY ISSUE				DRAWA	LHR	DATE	2021-07-24	APPELLATION		PAGE OF			
				STANDA-		DATE		美特鋁質有限公司 MIDI Aluminium Fabricator Ltd.					
				RDIZATION		DATE							
				TO SIGN		DATE							
				AUDITING		DATE							
MARKER	MODIFY	FILE NO	SIGNATURE	DATE	APPROV	DATE							

C.W 轉角零件 (地)

CUSTOMER	CUSTOMER APPROVAL	CUST PART NO.	AL-CW-M8(0)
		SECTION NO.	X 85978

a=0.1r
b=0.2r
c=0.3r
d=0.4r
e=0.5r
f=0.8r
g=1.0r
h=3.0r

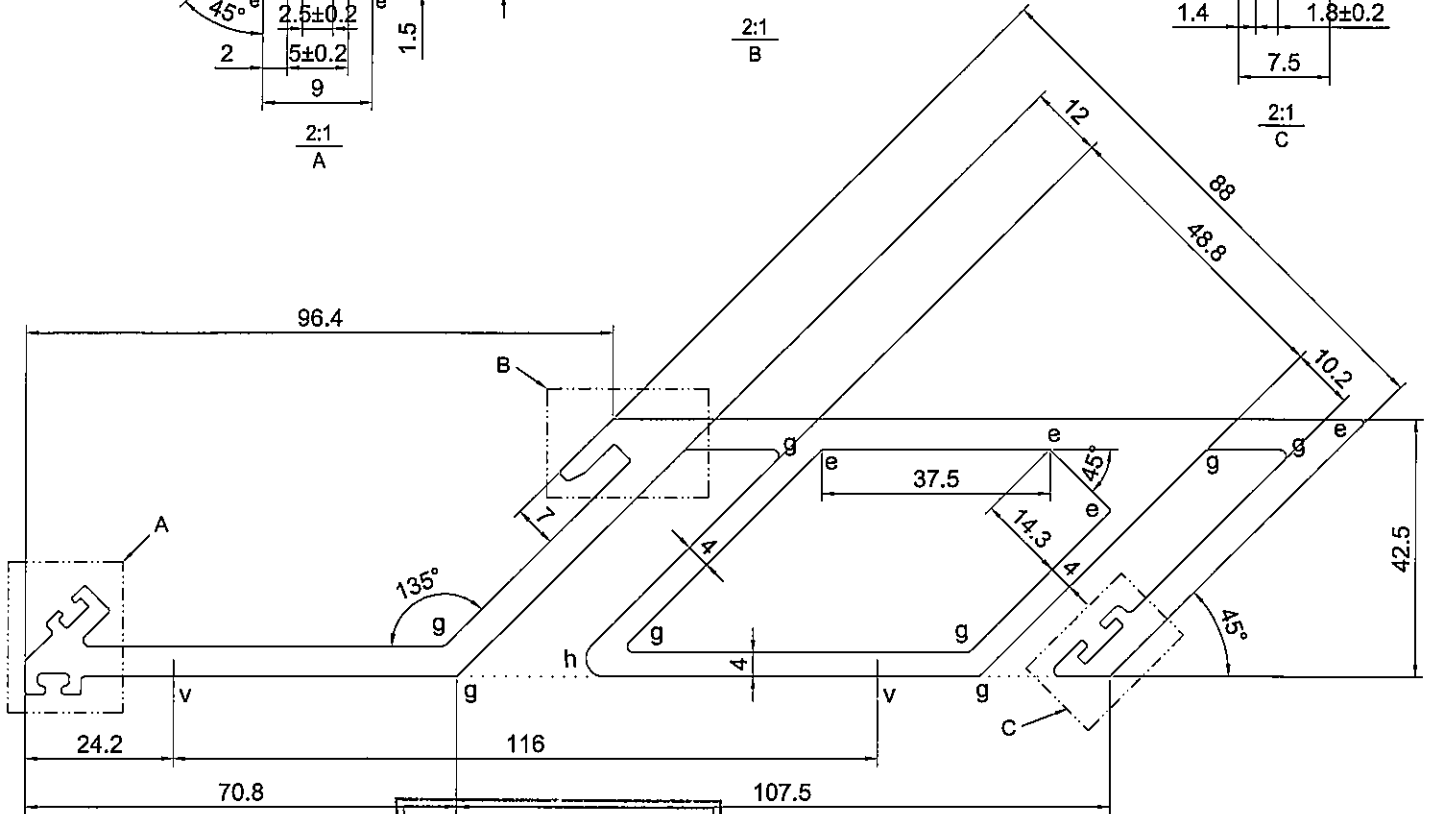
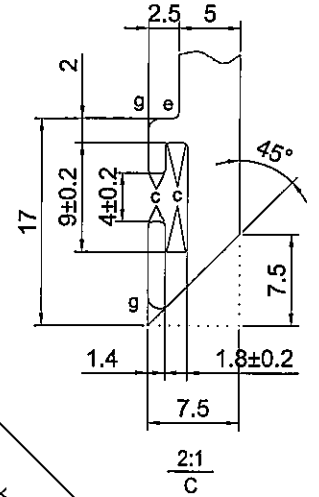
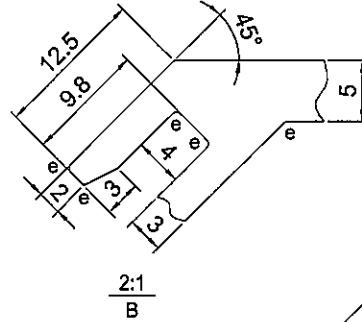
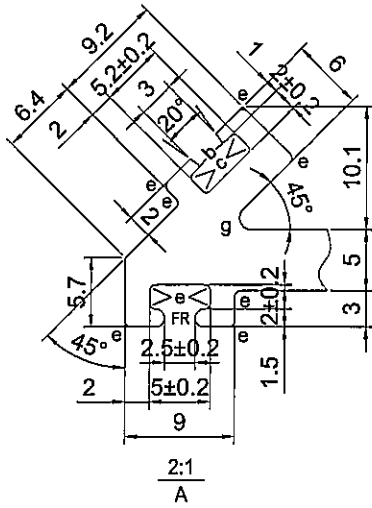

美特鋁質有限公司	
承認圖面	
日期	31/08/21

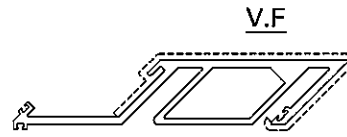

SCALE 1:4

SIGNATURE GRADEING	HIGH SIGNATURE GRADEING	C.C.DIA(MM)	224.60						
AREA (SQ MM)	2329.48	UNSPECIFIED THICKNESS	5.0	PERIMETER (MM)	770.79	STANDARD		SCALE	1:1
MASS (KG/M)	6.313	UNSPECIFIED CORNERS	-	SURFACE AREA	264.5	ALLOY	6063-T6	VERSION	A
COMPANY ISSUE		DRAWA	LHR	DATE	2021-07-24	APELLATION	PAGE OF		
		STANDA-RDIZATION		DATE		美特鋁質有限公司 MIDI Aluminium Fabricator Ltd.			
		TO SIGN		DATE					
		AUDITING		DATE					
MARKER	MODIFY	FILE NO	SIGNATURE	DATE	APPROV				

C.W 轉角主任 ADAPTOR 01

CUSTOMER	CUSTOMER APPROVAL	CUST PART NO.	AL-CW-M11(0)
		SECTION NO.	X85979

- a=0.1r
- b=0.2r
- c=0.3r
- d=0.4r
- e=0.5r
- f=0.8r
- g=1.0r
- h=3.0r

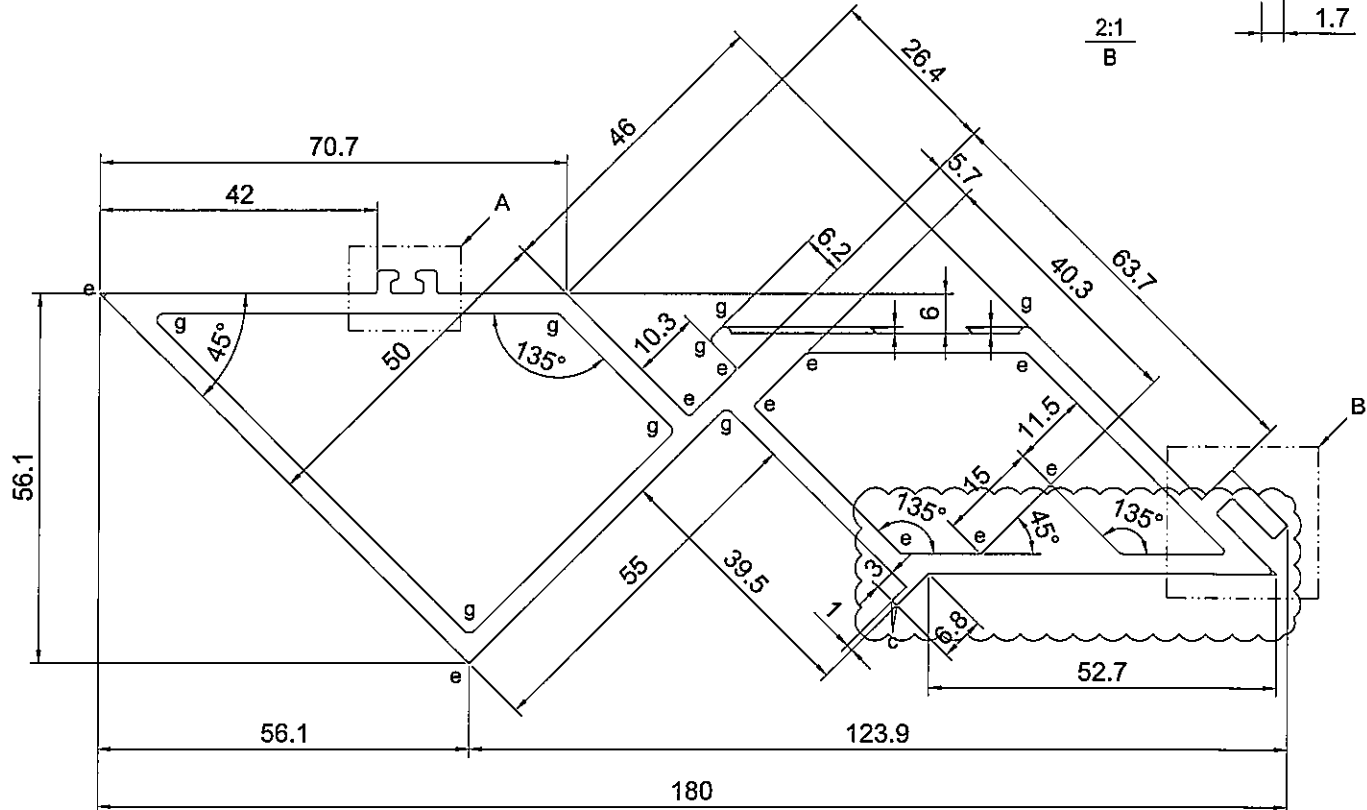
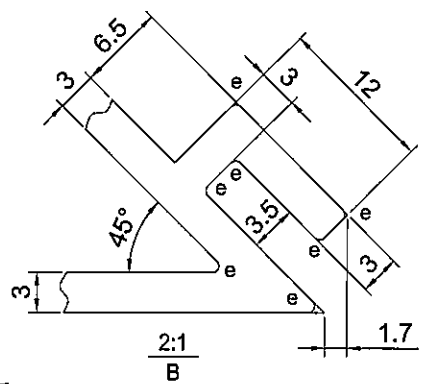
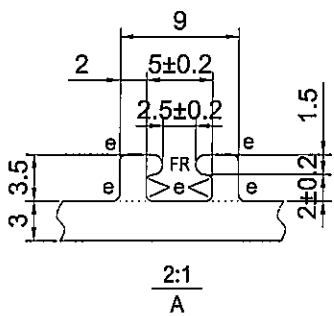

美特鋁質有限公司	
承認圖面	
日期	31/08/21

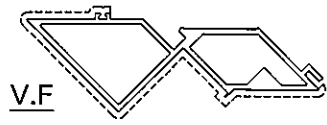

SCALE 1:4

SIGNATURE GRADEING	HIGH SIGNATURE GRADEING	C.C.DIA(MM)	183.40		PERIMETER (MM)	495.96	STANDARD	SCALE	1:1	
AREA (SQ MM)	1467.44	UNSPECIFIED THICKNESS	3.0		SURFACE AREA	301.6	ALLOY	6063-T6	VERSION	A
MASS (KG/M)	3.977	UNSPECIFIED CORNERS	-		DATE	2021-07-24	APPELLATION	PAGE OF		
COMPANY ISSUE			DRAWA	LHR	DATE					
			STANDA-RDIZATION		DATE					
			TO SIGN		DATE					
			AUDITING		DATE					
MARKER	MODIFY	FILE NO	SIGNATURE	DATE	APPROV		DATE			

美特鋁質有限公司
MIDI Aluminium Fabricator Ltd

C1W 轉角主龍 Adapter 02

CUSTOMER	CUSTOMER APPROVAL	CUST PART NO.	AL-CW-M12(0)
		SECTION NO.	X85980

a=0.1r
 b=0.2r
 c=0.3r
 d=0.4r
 e=0.5r
 f=0.8r
 g=1.0r
 h=3.0r

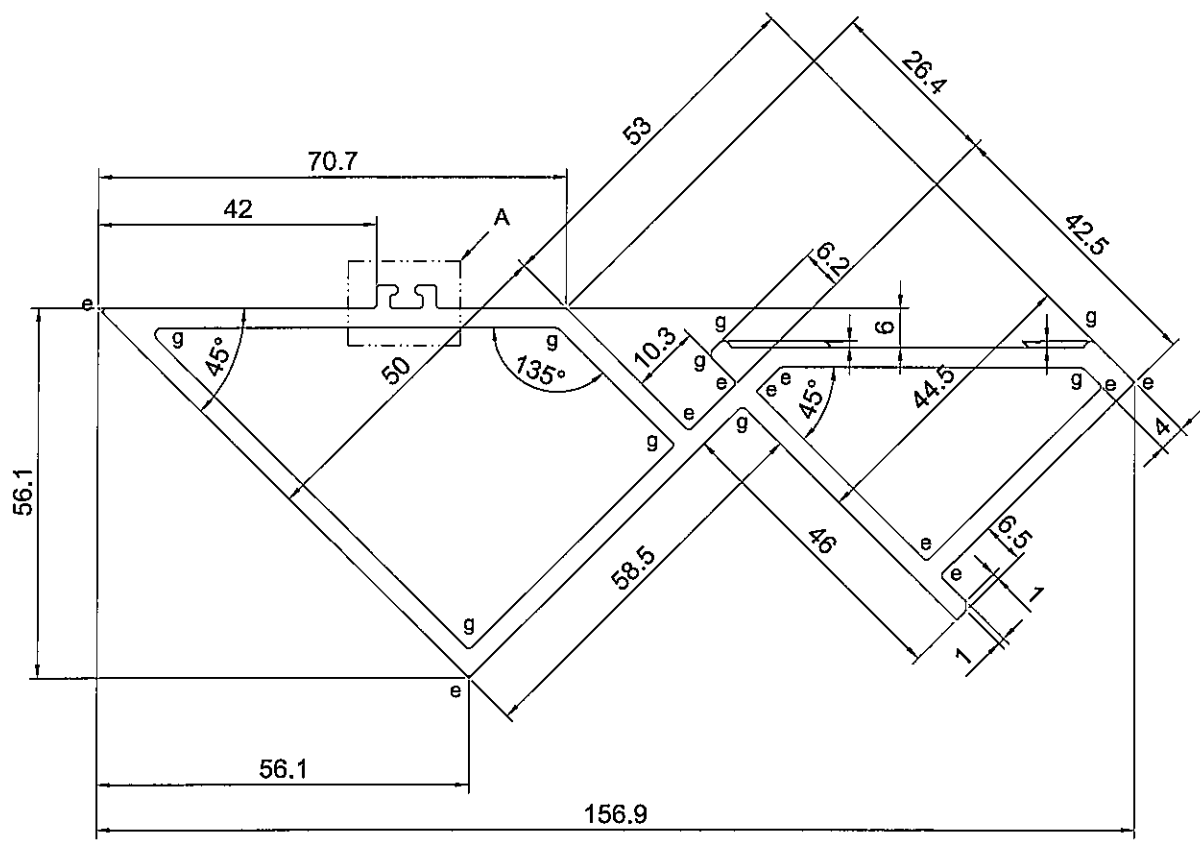
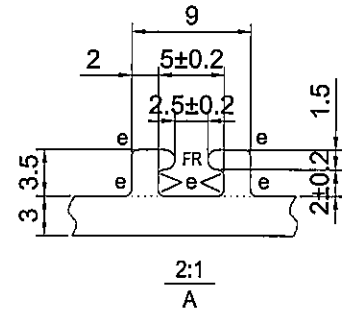

美特鋁質有限公司	
承認圖面	<i>[Signature]</i>
日期	31/08/21

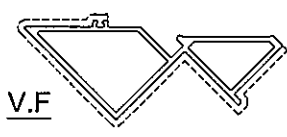

SCALE 1:4

SIGNATURE GRADEING	HIGH SIGNATURE GRADEING	C.C.DIA(MM)	157.30						
AREA (SQ MM)	1169.12	UNSPECIFIED THICKNESS	3.0	PERIMETER (MM)	429.61	STANDARD		SCALE	1:1
MASS (KG/M)	3.168	UNSPECIFIED CORNERS	-	SURFACE AREA	296.74	ALLOY	6063-T6	VERSION	
COMPANY ISSUE		DRAWN	LHR	DATE	2021-07-24	APELLATION	PAGE OF		
		STANDARDIZATION		DATE					
		TO SIGN		DATE					
		AUDITING		DATE					
MARKER	MODIFY	FILE NO	SIGNATURE	DATE	APPROV				

美特鋁質有限公司
 MIDI Aluminium Fabricator Ltd

AL 橫料 (頂)

CUSTOMER	CUSTOMER APPROVAL	CUST PART NO.	AL-CW-T2(0)
		SECTION NO.	X85982

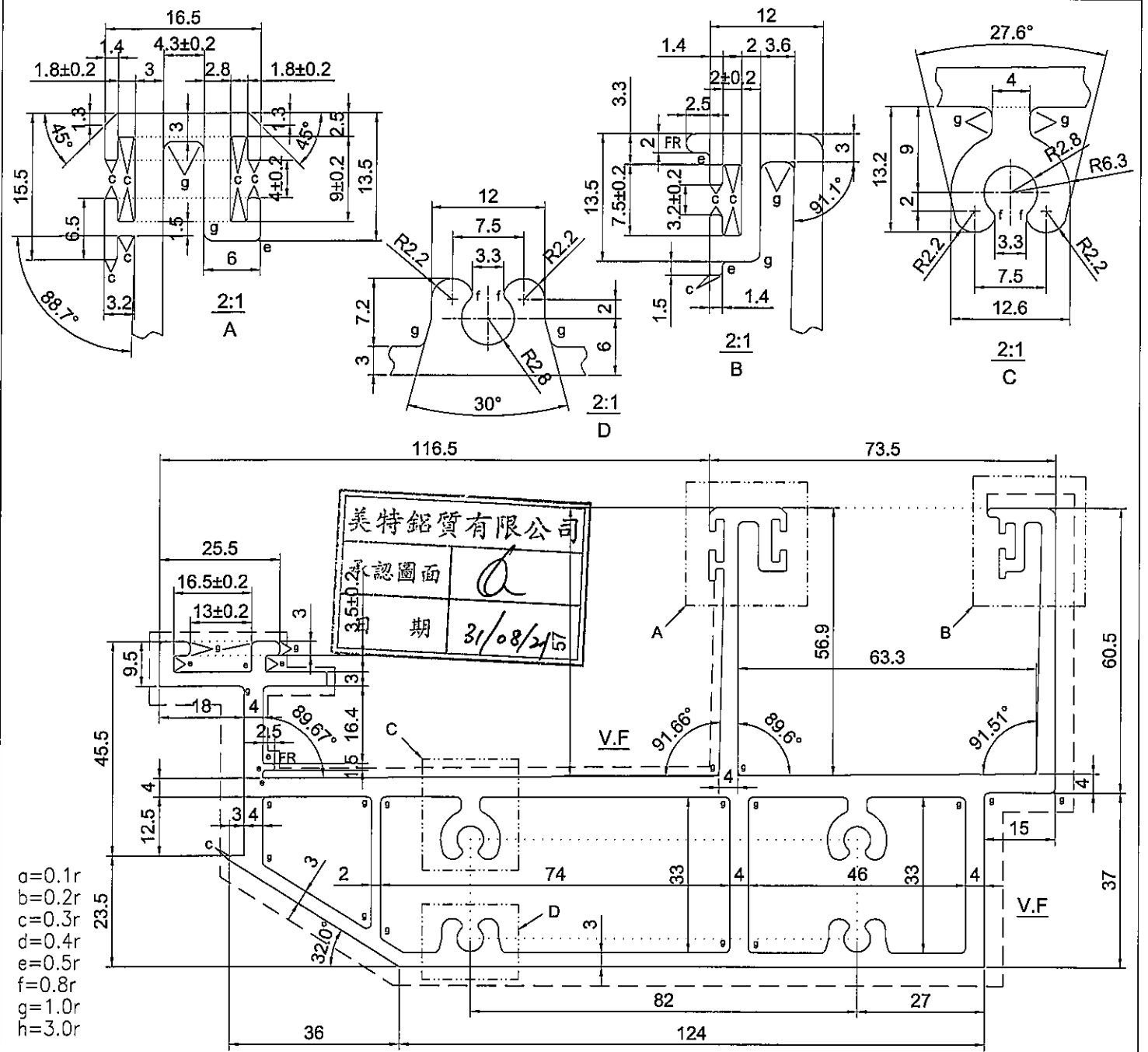

SIGNATURE GRADEING	HIGH SIGNATURE GRADEING	C.C.DIA(MM)	197.00						
AREA (SQ MM)	2720.78	UNSPECIFIED THICKNESS	-	PERIMETER (MM)	921.57	STANDARD		SCALE	1:1
MASS (KG/M)	7.373	UNSPECIFIED CORNERS	-	SURFACE AREA	601.0	ALLOY	6063-T6	VERSION	A
COMPANY ISSUE			DRAWA	LHR	DATE	2021-07-24		PAGE OF	
			STANDARDIZATION		DATE				
			TO SIGN		DATE				
			AUDITING		DATE				
MARKER	MODIFY	FILE NO	SIGNATURE	DATE	APPROV				

美特鋁質有限公司
 MIDI Aluminium Fabricator Ltd.

C.W 橫料

CUSTOMER	CUSTOMER APPROVAL	CUST PART NO.	AL-CW-T3(0)
		SECTION NO.	X85983

a=0.1r
b=0.2r
c=0.3r
d=0.4r
e=0.5r
f=0.8r
g=1.0r
h=3.0r
k=1.6r

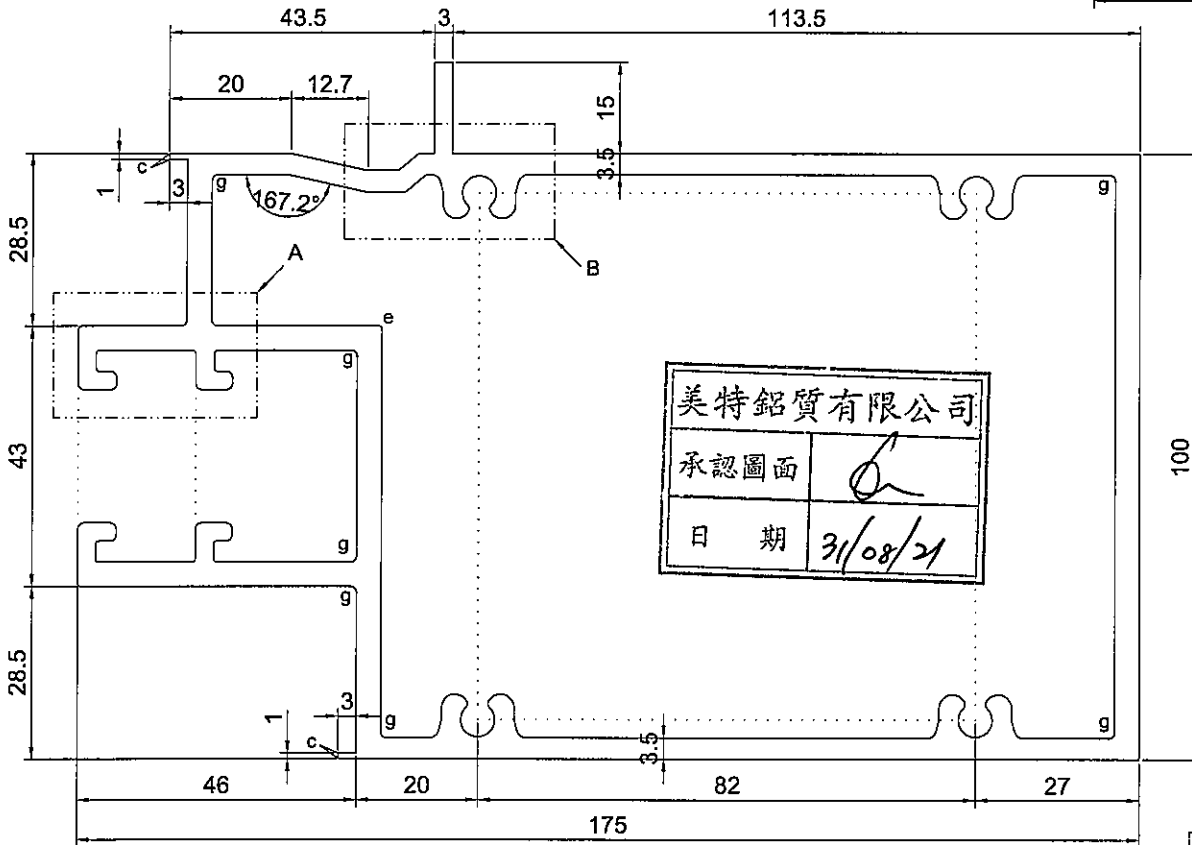
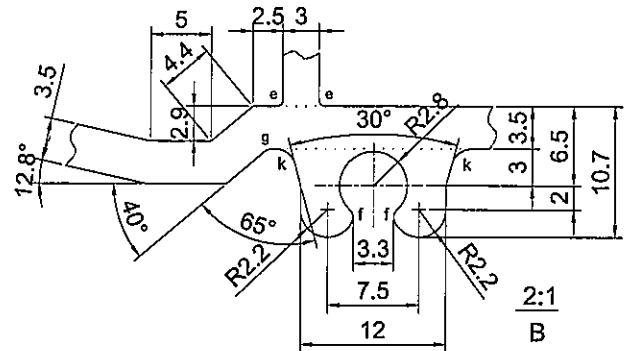
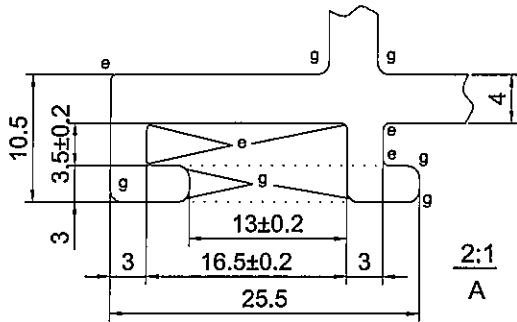

美特鋁質有限公司	
承認圖面	
日期	31/08/21

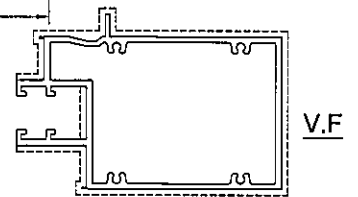

SCALE 1:4

SIGNATURE GRADEING	HIGH SIGNATURE GRADEING	C.C.DIA(MM)	191.53						
AREA (SQ MM)	2509.21	UNSPECIFIED THICKNESS	4.0	PERIMETER (MM)	753.38	STANDARD		SCALE	1:1
MASS (KG/M)	6.800	UNSPECIFIED CORNERS	-	SURFACE AREA	586.0	ALLOY	6063-T6	VERSION	A
COMPANY ISSUE			DRAWN	LHR	DATE	2021-07-24	APELLATION	PAGE OF	
			STANDARDIZATION		DATE				
			TO SIGN		DATE				
			AUDITING		DATE				
MARKER	MODIFY	FILE NO	SIGNATURE	DATE	APPROV				

美特鋁質有限公司
MIDI Aluminium Fabricator Ltd.

cw 生智頂控料

CUSTOMER	CUSTOMER APPROVAL	CUST PART NO.	AL-CW-T4(0)
		SECTION NO.	X85984

a=0.1r
 b=0.2r
 c=0.3r
 d=0.4r
 e=0.5r
 f=0.8r
 g=1.0r
 h=3.0r
 k=1.6r

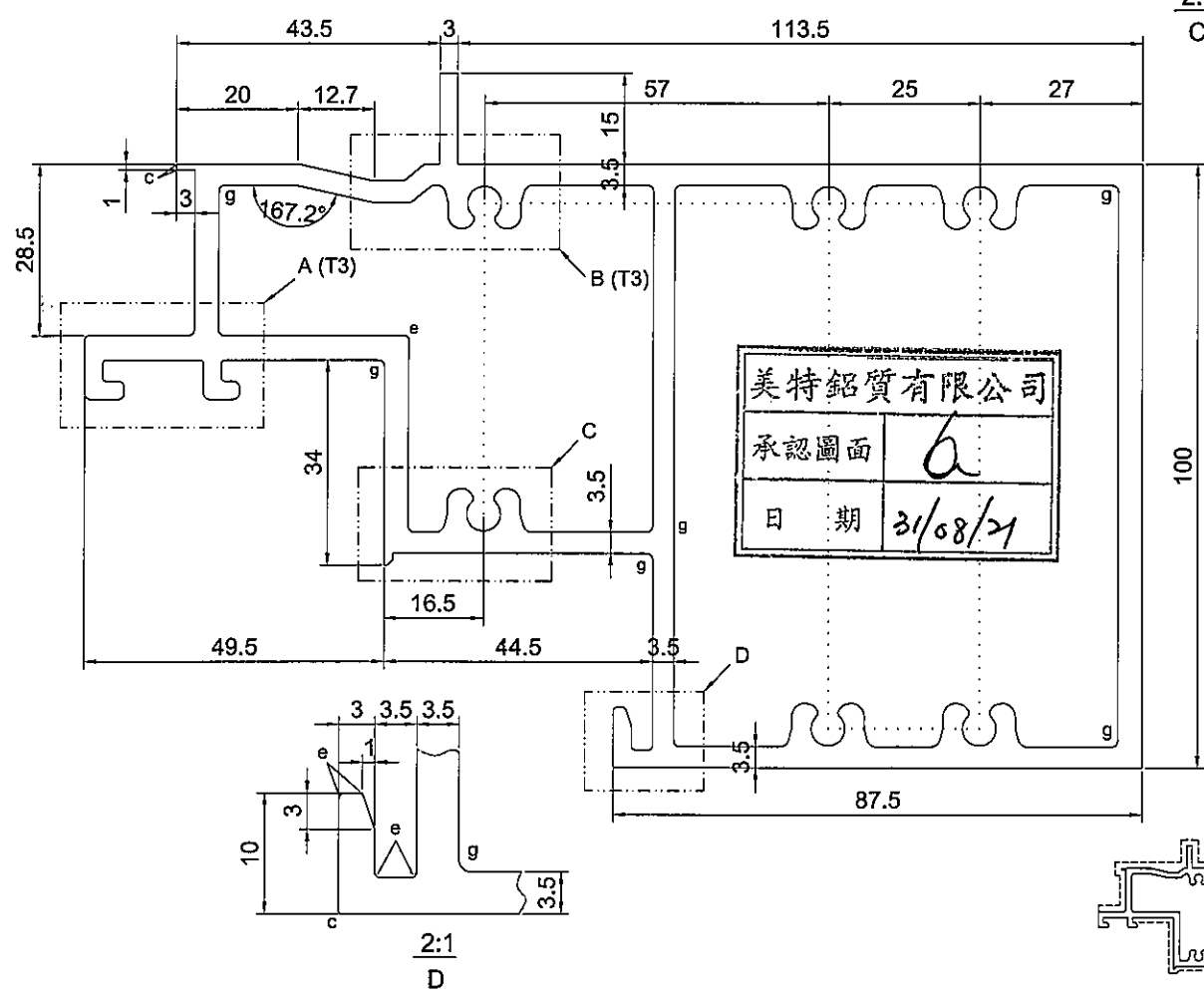
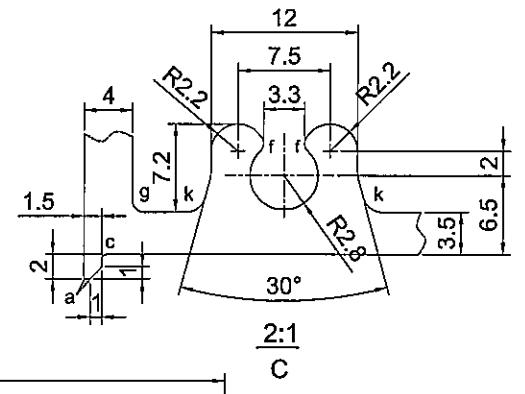

美特鋁質有限公司
 承認圖面
 日期 31/08/21

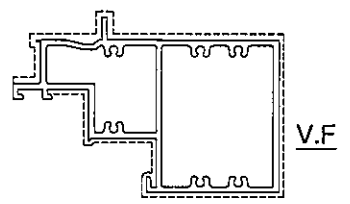

SCALE 1:4

SIGNATURE GRADEING	HIGH SIGNATURE GRADEING	C.C.DIA(MM)	191.53						
AREA (SQ MM)	2604.17	UNSPECIFIED THICKNESS	4.0	PERIMETER (MM)	649.40	STANDARD		SCALE	1:1
MASS (KG/M)	7.057	UNSPECIFIED CORNERS	-	SURFACE AREA	587.1	ALLOY	6063-T6	VERSION	A
COMPANY ISSUE		DRAWN	LHR	DATE	2021-07-24	APELLATION	PAGE OF		
		STANDARDIZATION		DATE		美特鋁質有限公司 MIDI Aluminium Fabricator Ltd.			
		TO SIGN		DATE					
		AUDITING		DATE					
MARKER	MODIFY	FILE NO	SIGNATURE	DATE	APPROV				

C.W. ADAPTOR

CUSTOMER	CUSTOMER APPROVAL	CUST PART NO.	AL-CW-A02(0)
		SECTION NO.	X85987

a=0.1r
 b=0.2r
 c=0.3r
 d=0.4r
 e=0.5r
 f=0.8r
 g=1.0r
 h=3.0r

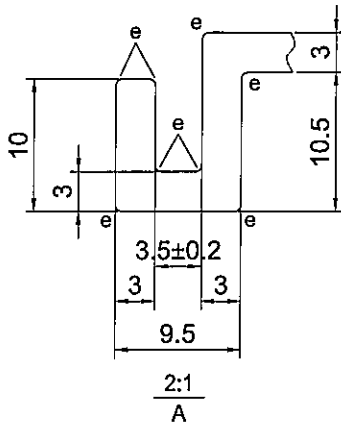

美特鋁質有限公司	
承認圖面	<i>[Signature]</i>
日期	21/08/21

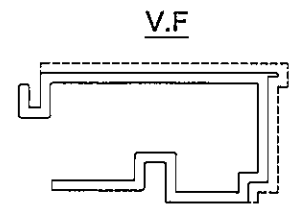
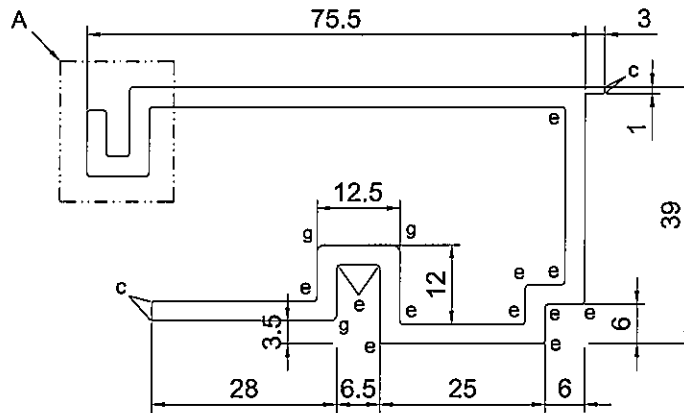

SCALE 1:2

SIGNATURE GRADEING	HIGH SIGNATURE GRADEING	C.C.DIA(MM)	81.80						
AREA (SQ MM)	638.39	UNSPECIFIED THICKNESS	3.0	PERIMETER (MM)	429.91	STANDARD		SCALE	1:1
MASS (KG/M)	1.730	UNSPECIFIED CORNERS	-	SURFACE AREA	120.0	ALLOY	6063-T6	VERSION	A
COMPANY ISSUE		DRAWN	LHR	DATE	2021-07-26	APELLATION		PAGE OF	
		STANDARDIZATION		DATE		美特鋁質有限公司 MIDI Aluminium Fabricator Ltd			
		TO SIGN		DATE					
		AUDITING		DATE					
MARKER	MODIFY	FILE NO	SIGNATURE	DATE	APPROV				

C.W 玻璃扣線

CUSTOMER	CUSTOMER APPROVAL	CUST PART NO.	AL-CW-A03(0)
		SECTION NO.	X85988

a=0.1r
 b=0.2r
 c=0.3r
 d=0.4r
 e=0.5r
 f=0.8r
 g=1.0r
 h=3.0r

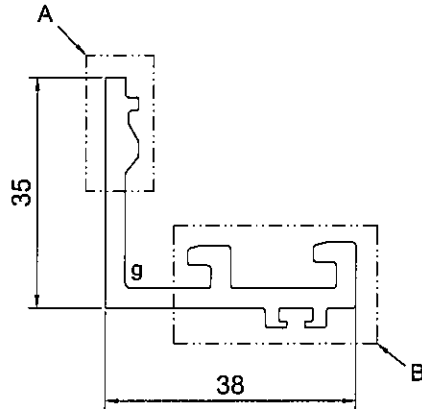
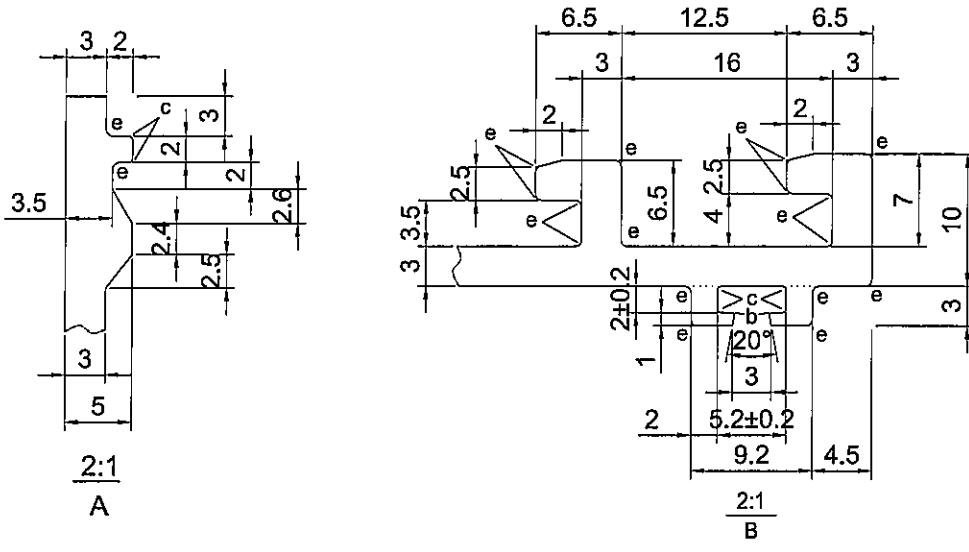

美特鋁質有限公司	
承認圖面	
日期	3/10/21

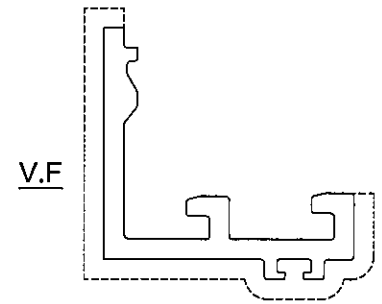

SCALE 1:1

SIGNATURE GRADEING	HIGH SIGNATURE GRADEING	C.C.DIA(MM)	51.66						
AREA (SQ MM)	300.71	UNSPECIFIED THICKNESS	3.0	PERIMETER (MM)	202.44	STANDARD		SCALE	1:1
MASS (KG/M)	0.815	UNSPECIFIED CORNERS	-	SURFACE AREA	101.32	ALLOY	6063-T6	VERSION	A
COMPANY ISSUE			DRAWN	LHR	DATE	2021-07-26	APELLATION	PAGE OF	
			STANDARDIZATION		DATE		美特鋁質有限公司 MIDI Aluminium Fabricator Ltd		
			TO SIGN		DATE				
			AUDITING		DATE				
MARKER	MODIFY	FILE NO	SIGNATURE	DATE	APPROV	DATE			

ADAPTER

CUSTOMER	CUSTOMER APPROVAL	CUST PART NO.	AL-CW-A05(0)
		SECTION NO.	X85990

- a=0.1r
- b=0.2r
- c=0.3r
- d=0.4r
- e=0.5r
- f=0.8r
- g=1.0r
- h=3.0r

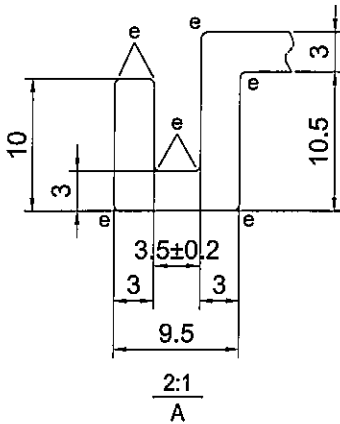

美特鋁質有限公司	
承認圖面	6
日期	31/08/21

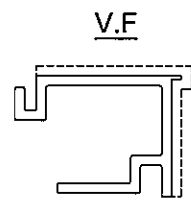
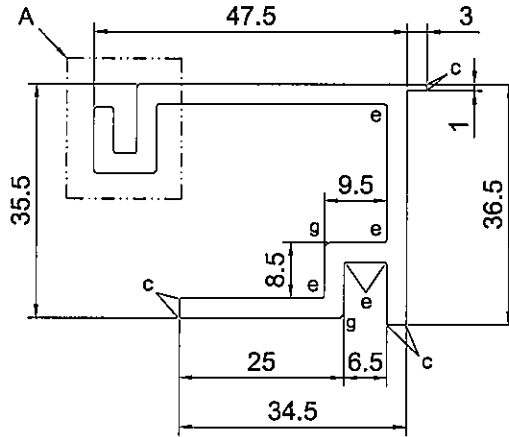

SCALE 1:2

SIGNATURE GRADEING	HIGH SIGNATURE GRADEING	C.C.DIA(MM)	58.50						
AREA (SQ MM)	418.12	UNSPECIFIED THICKNESS	3.0	PERIMETER (MM)	284.58	STANDARD		SCALE	1:1
MASS (KG/M)	1.133	UNSPECIFIED CORNERS	-	SURFACE AREA	83.52	ALLOY	6063-T6	VERSION	A
COMPANY ISSUE		DRAWN	LHR	DATE	2021-07-26	APELLATION	PAGE OF		
		STANDARDIZATION		DATE		 美特鋁質有限公司 MIDI Aluminium Fabricator Ltd			
		TO SIGN		DATE					
		AUDITING		DATE					
MARKER	MODIFY	FILE NO	SIGNATURE	DATE	APPROV				

CW 型角 零件圖

CUSTOMER	CUST PART NO.	AL-CW-A07(0)
	SECTION NO.	X85992

a=0.1r
 b=0.2r
 c=0.3r
 d=0.4r
 e=0.5r
 f=0.8r
 g=1.0r
 h=3.0r

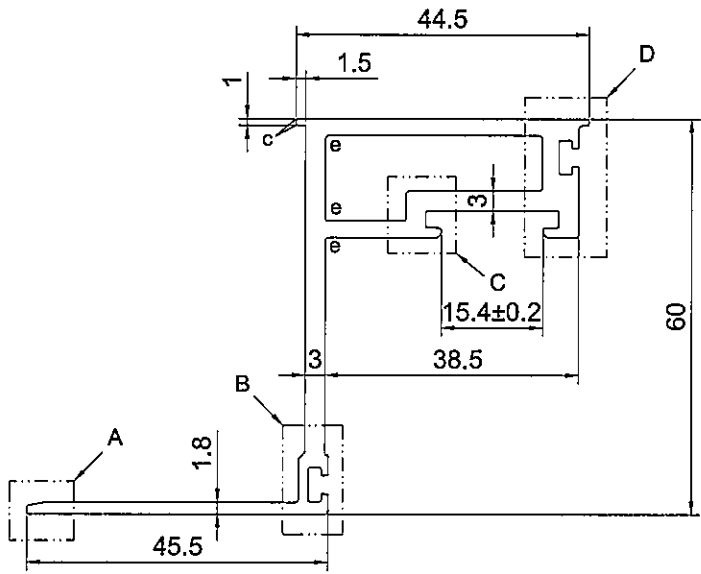
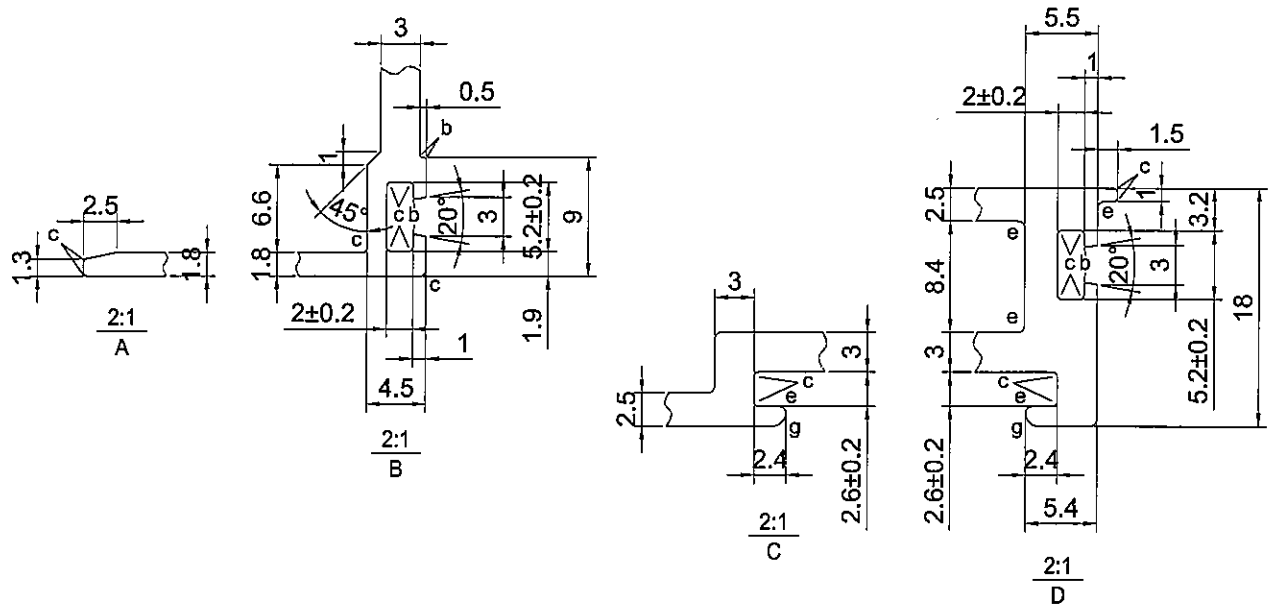

美特鋁質有限公司	
承認圖面	<i>[Signature]</i>
日期	31/08/21

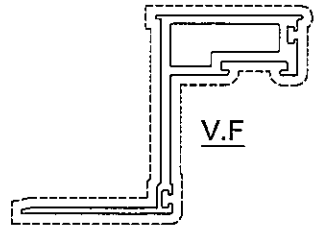

SCALE 1:2

SIGNATURE GRADEING	HIGH SIGNATURE GRADEING	C.C.DIA(MM)	104.04						
AREA (SQ MM)	526.58	UNSPECIFIED THICKNESS	2.5	PERIMETER (MM)	327.25	STANDARD		SCALE	1:1
MASS (KG/M)	1.427	UNSPECIFIED CORNERS	-	SURFACE AREA	327.25	ALLOY	6063-T6	VERSION	A
COMPANY ISSUE			DRAWN	LHR	DATE	2021-07-26	APPELLATION	PAGE OF	
			STANDARDIZATION		DATE				
			TO SIGN		DATE				
			AUDITING		DATE				
MARKER	MODIFY	FILE NO	SIGNATURE	DATE	APPROV		DATE		

美特鋁質有限公司
 MIDI Aluminium Fabricator Ltd

22

ADDITOR

CUSTOMER	CUST PART NO.	AL-CW-A08(0)
	SECTION NO.	X 85993

a=0.1r
 b=0.2r
 c=0.3r
 d=0.4r
 e=0.5r
 f=0.8r
 g=1.0r
 h=3.0r

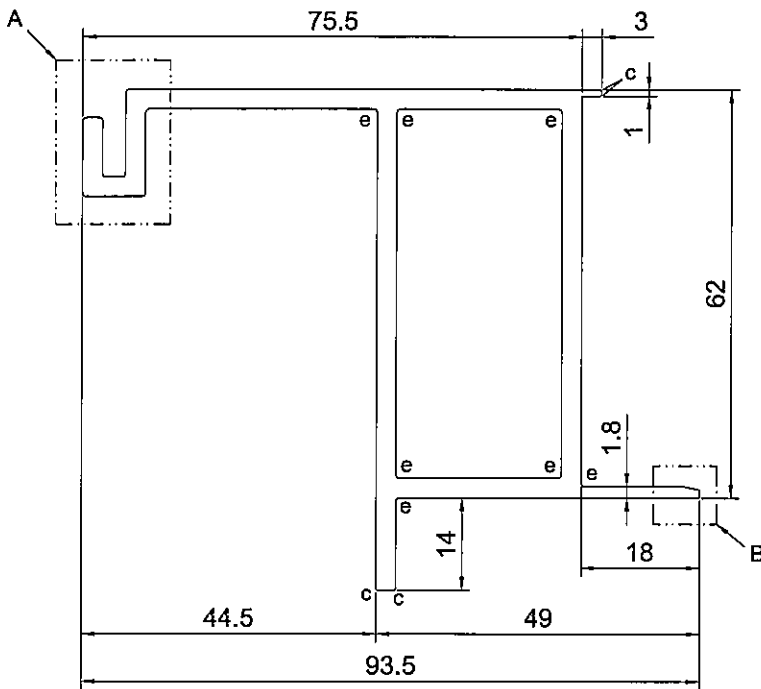
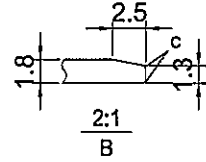
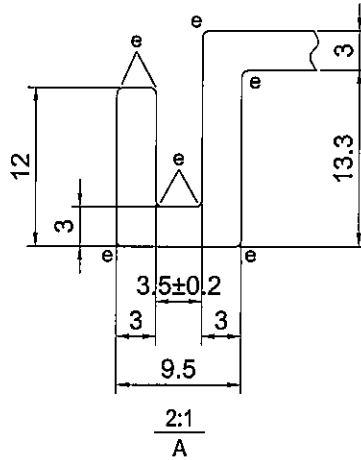

美特鋁質有限公司	
承認圖面	6
日期	31/08/21

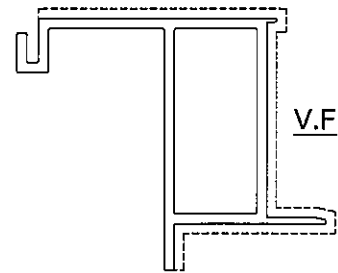

SCALE 1:2

SIGNATURE GRADEING	HIGH SIGNATURE GRADEING	C.C.DIA(MM)	109.87						
AREA (SQ MM)	799.29	UNSPECIFIED THICKNESS	3.0	PERIMETER (MM)	386.03	STANDARD		SCALE	1:1
MASS (KG/M)	2.166	UNSPECIFIED CORNERS	-	SURFACE AREA	214.15	ALLOY	6063-T6	VERSION	A
COMPANY ISSUE			DRAWN	LHR	DATE	2021-07-26	APPELLATION	PAGE OF	
			STANDARDIZATION		DATE				
			TO SIGN		DATE				
			AUDITING		DATE				
MARKER	MODIFY	FILE NO	SIGNATURE	DATE	APPROV		DATE		

美特鋁質有限公司
 MIDI Aluminium Fabricator Ltd

✓

ADAPTOR

CUSTOMER	CUSTOMER APPROVAL	CUST PART NO.	AL-CW-A10(0)
		SECTION NO.	X85995

a=0.1r
 b=0.2r
 c=0.3r
 d=0.4r
 e=0.5r
 f=0.8r
 g=1.0r
 h=3.0r

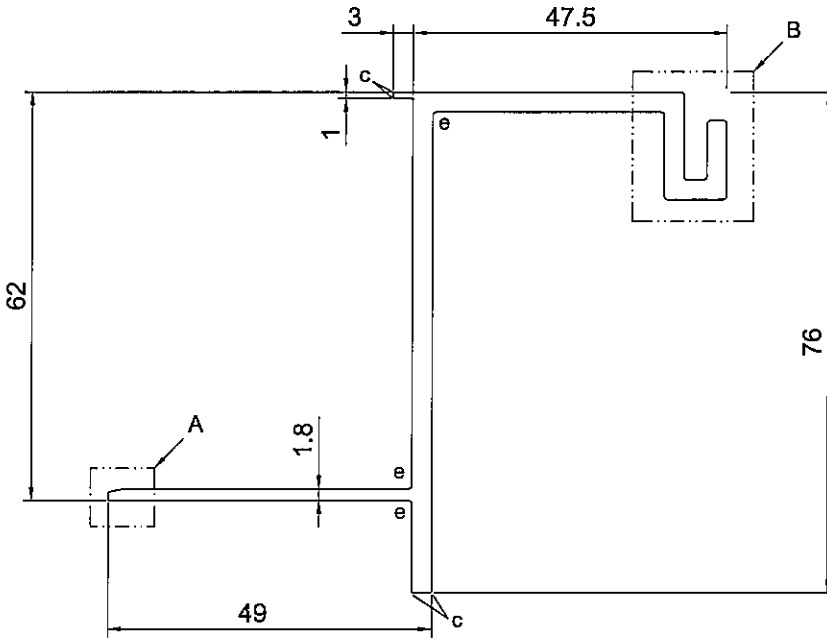
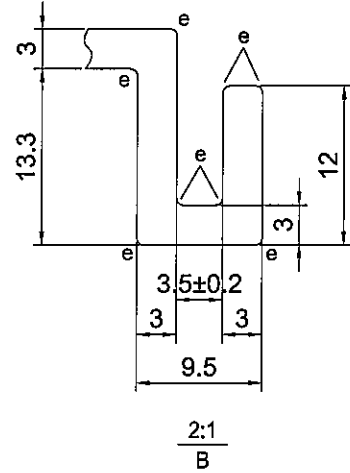
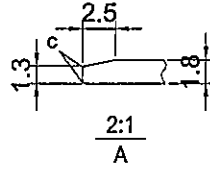

美特鋁質有限公司	
承認圖面	6
日期	31/08/21

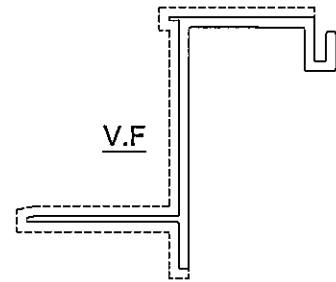

SCALE 1:2

SIGNATURE GRADEING	HIGH SIGNATURE GRADEING	C.C.DIA(MM)	109.87						
AREA (SQ MM)	513.47	UNSPECIFIED THICKNESS	3.0	PERIMETER (MM)	386.03	STANDARD		SCALE	1:1
MASS (KG/M)	1.392	UNSPECIFIED CORNERS	-	SURFACE AREA	217.0	ALLOY	6063-T6	VERSION	
COMPANY ISSUE			DRAWN	LHR	DATE	2021-08-28	APPELLATION	PAGE OF	
			STANDARDIZATION		DATE				
			TO SIGN		DATE				
			AUDITING		DATE				
MARKER	MODIFY	FILE NO	SIGNATURE	DATE	APPROV		DATE		

美特鋁質有限公司
 MIDI Aluminium Fabricator Ltd

25

C.W 掛石碼

CUSTOMER	CUST PART NO.	AL-CW-B01(0)
	SECTION NO.	X 85996

$a=0.1r$
 $b=0.2r$
 $c=0.3r$
 $d=0.4r$
 $e=0.5r$
 $f=0.8r$
 $g=1.0r$
 $h=3.0r$

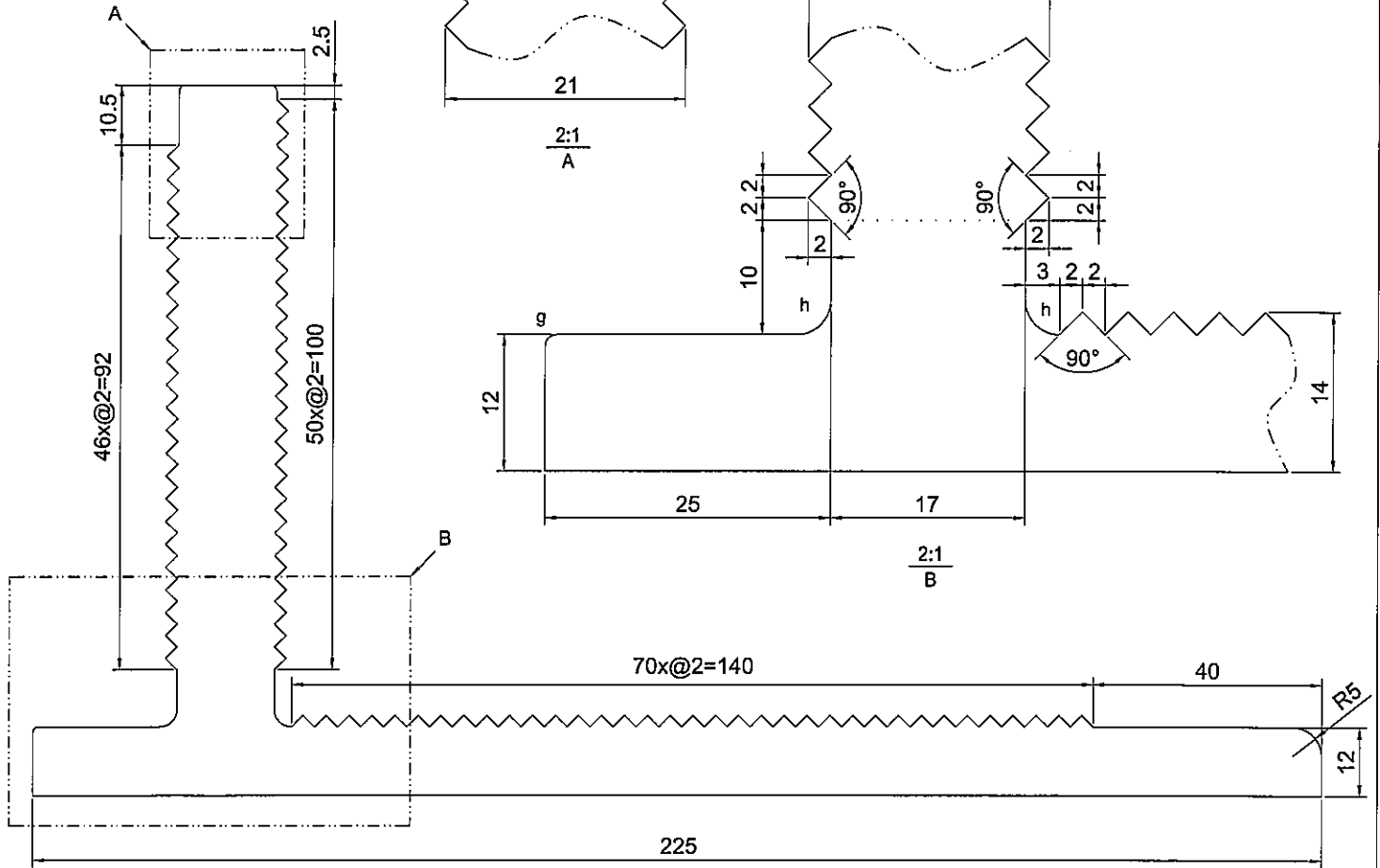
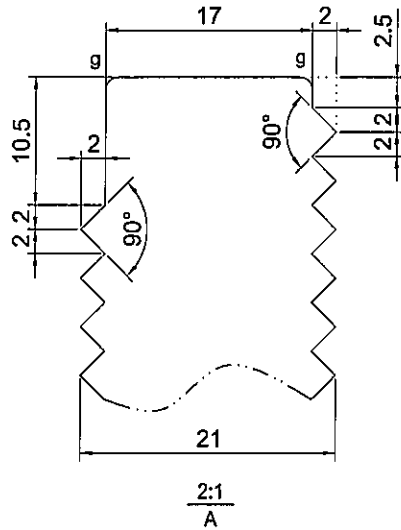

美特鋁質有限公司	
承認圖面	
日期	31/08/21

SIGNATURE GRADEING	HIGH SIGNATURE GRADEING	C.C.DIA(MM)	240.29						
AREA (SQ MM)	4942.35	UNSPECIFIED THICKNESS	-	PERIMETER (MM)	830.51	STANDARD		SCALE	1:1
MASS (KG/M)	13.394	UNSPECIFIED CORNERS	-	SURFACE AREA	-	ALLOY	6061-T6	VERSION	A
COMPANY ISSUE		DRAWN	LHR	DATE	2021-07-26	APELLATION	PAGE OF		
		STANDARDIZATION		DATE		美特鋁質有限公司 MIDI Aluminium Fabricator Ltd.			
		TO SIGN		DATE					
		AUDITING		DATE					
MARKER	MODIFY	FILE NO	SIGNATURE	DATE	APPROV				

C.W 掛碼鋁角

CUSTOMER	CUSTOMER APPROVAL	CUST PART NO.	AL-CW-B02(0)
		SECTION NO.	X 89997

a=0.1r
 b=0.2r
 c=0.3r
 d=0.4r
 e=0.5r
 f=0.8r
 g=1.0r
 h=3.0r

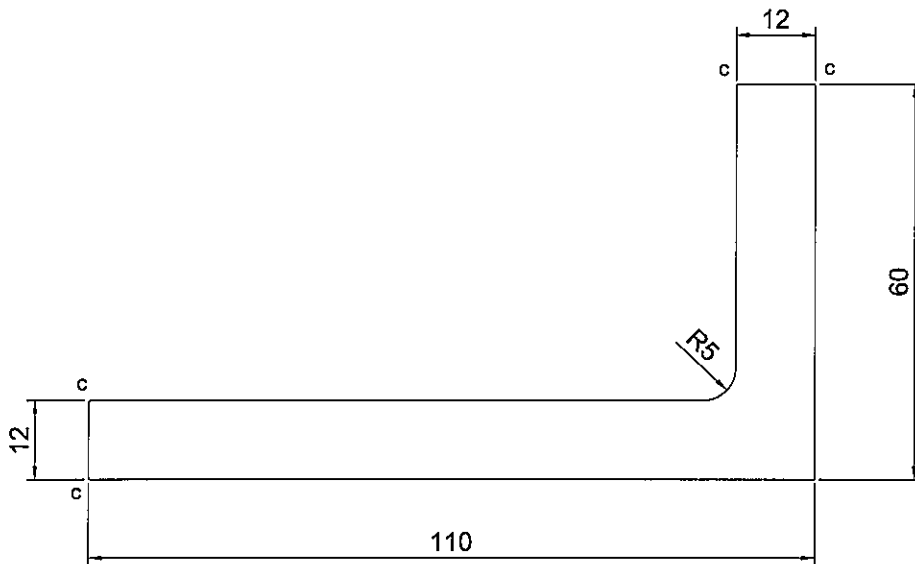

美特鋁質有限公司	
承認圖面	
日期	21/08/21

SIGNATURE GRADEING	HIGH SIGNATURE GRADEING	C.C.DIA(MM)	125.30						
AREA (SQ MM)	1901.37	UNSPECIFIED THICKNESS	-	PERIMETER (MM)	337.85	STANDARD		SCALE	1:1
MASS (KG/M)	5.153	UNSPECIFIED CORNERS	-	SURFACE AREA	-	ALLOY	6061-T6	VERSION	A
COMPANY ISSUE		DRAWN	LHR	DATE	2021-07-26	APPELLATION	PAGE OF		
		STANDARDIZATION		DATE		美特鋁質有限公司 MIDI Aluminium Fabricator Ltd			
		TO SIGN		DATE					
		AUDITING		DATE					
MARKER	MODIFY	FILE NO	SIGNATURE	DATE	APPROV				

27

C.W 掛碼

CUSTOMER	CUSTOMER APPROVAL	CUST PART NO.	AL-CW-B03(0)
		SECTION NO.	X85998

a=0.1r
 b=0.2r
 c=0.3r
 d=0.4r
 e=0.5r
 f=0.8r
 g=1.0r
 h=3.0r

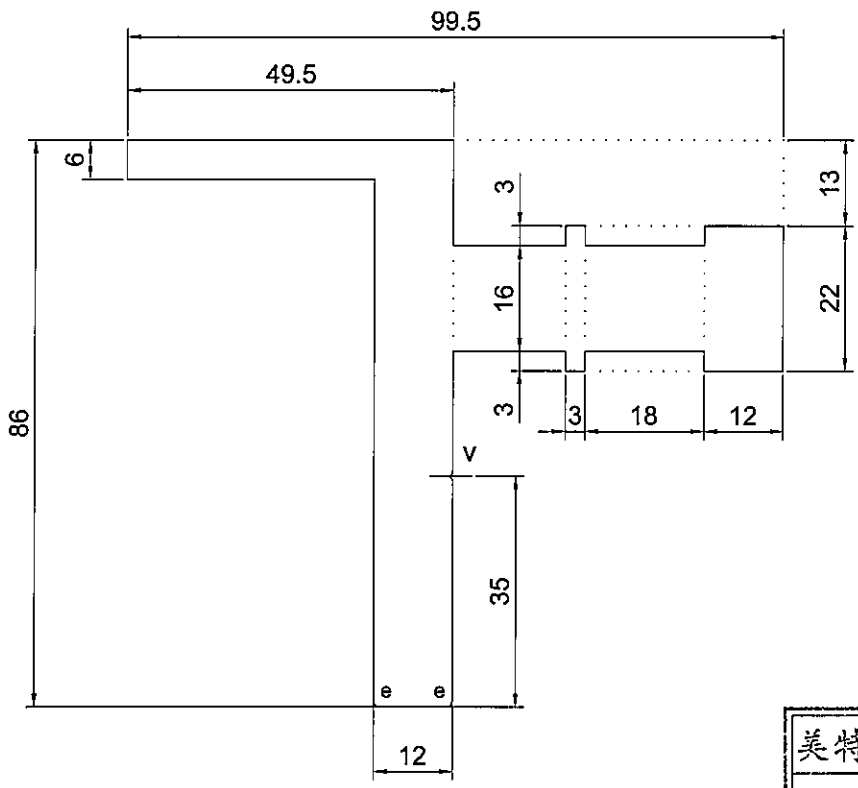

美特鋁質有限公司	
承認圖面	6
日期	31/08/21

SIGNATURE GRADEING	HIGH SIGNATURE GRADEING	C.C.DIA(MM)	111.74						
AREA (SQ MM)	2146.18	UNSPECIFIED THICKNESS	-	PERIMETER (MM)	394.71	STANDARD		SCALE	1:1
MASS (KG/M)	5.816	UNSPECIFIED CORNERS	-	SURFACE AREA	-	ALLOY	6061-T6	VERSION	A
COMPANY ISSUE			DRAWN	LHR	DATE	2021-07-26	APPELLATION	PAGE OF	
			STANDARDIZATION		DATE		美特鋁質有限公司 MIDI Aluminium Fabricator Ltd		
			TO SIGN		DATE				
			AUDITING		DATE				
MARKER	MODIFY	FILE NO	SIGNATURE	DATE	APPROV	DATE			

C.W 轉角 新

CUSTOMER	CUSTOMER APPROVAL	CUST PART NO.	AL-CW-B04(0)
		SECTION NO.	X85999

a=0.1r
 b=0.2r
 c=0.3r
 d=0.4r
 e=0.5r
 f=0.8r
 g=1.0r
 h=3.0r

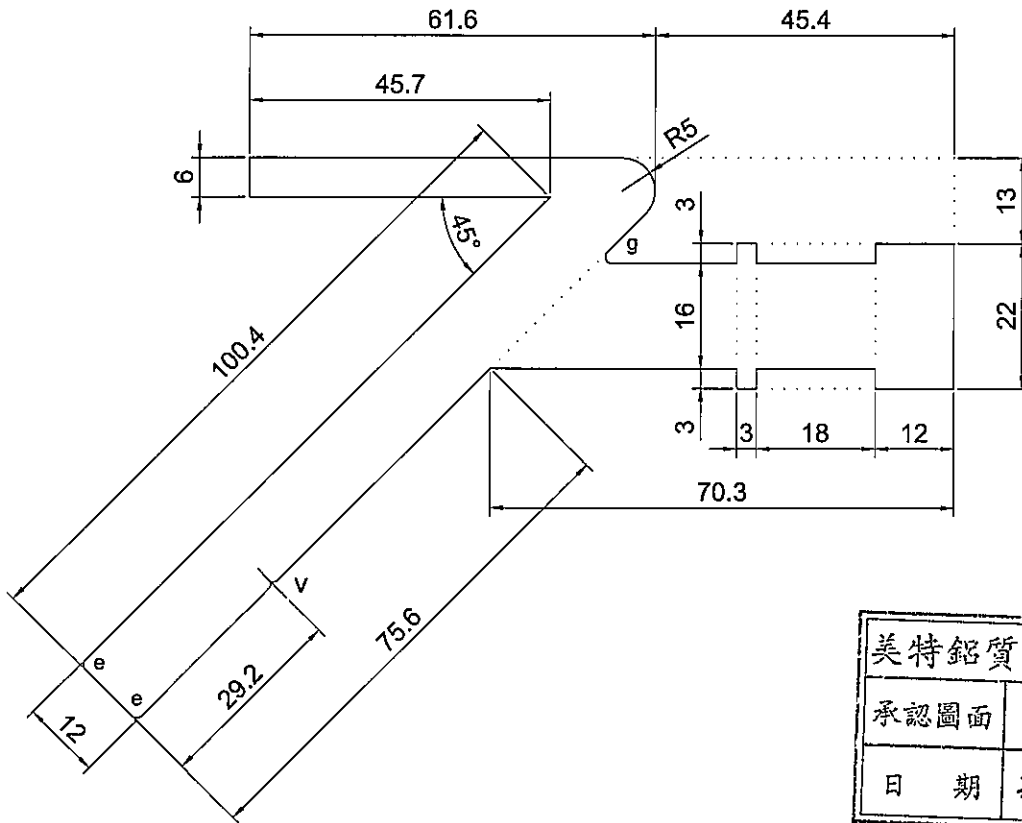

SIGNATURE GRADEING	HIGH SIGNATURE GRADEING	C.C.DIA(MM)	146.91						
AREA (SQ MM)	2727.10	UNSPECIFIED THICKNESS	-	PERIMETER (MM)	480.32	STANDARD		SCALE	1:1
MASS (KG/M)	7.390	UNSPECIFIED CORNERS	-	SURFACE AREA	-	ALLOY	6061-T6	VERSION	A
COMPANY ISSUE		DRAWN	LHR	DATE	2021-07-26	APELLATION		PAGE OF	
		STANDARDIZATION		DATE		美特鋁質有限公司 MIDI Aluminium Fabricator Ltd			
		TO SIGN		DATE					
		AUDITING		DATE					
MARKER	MODIFY	FILE NO	SIGNATURE	DATE	APPROV				

WASHER 01

CUSTOMER	CUSTOMER APPROVAL	CUST PART NO.	AL-CW-B05(0)
		SECTION NO.	X 86000

- a=0.1r
- b=0.2r
- c=0.3r
- d=0.4r
- e=0.5r
- f=0.8r
- g=1.0r
- h=3.0r

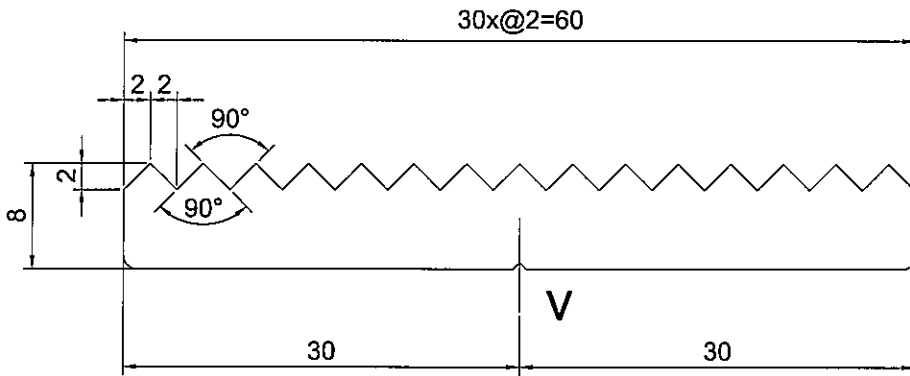

SCALE 2:1

美特鋁質有限公司	
承認圖面	
日期	31/08/21

SIGNATURE GRADEING	HIGH SIGNATURE GRADEING	C.C.DIA(MM)	60.30						
AREA (SQ MM)	419.32	UNSPECIFIED THICKNESS	-	PERIMETER (MM)	156.41	STANDARD		SCALE	1:1
MASS (KG/M)	1.136	UNSPECIFIED CORNERS	-	SURFACE AREA	-	ALLOY	6061-T6	VERSION	A
COMPANY ISSUE		DRAWN	LHR	DATE	2021-07-26	APPELLATION		PAGE OF	
		STANDARDIZATION		DATE		美特鋁質有限公司 MIDI Aluminium Fabricator Ltd			
		TO SIGN		DATE					
		AUDITING		DATE					
MARKER	MODIFY	FILE NO	SIGNATURE	DATE	APPROV				

RASHER 02

CUSTOMER	CUSTOMER APPROVAL	CUST PART NO.	AL-CW-B06(0)
		SECTION NO.	×86001

a=0.1r
 b=0.2r
 c=0.3r
 d=0.4r
 e=0.5r
 f=0.8r
 g=1.0r
 h=3.0r

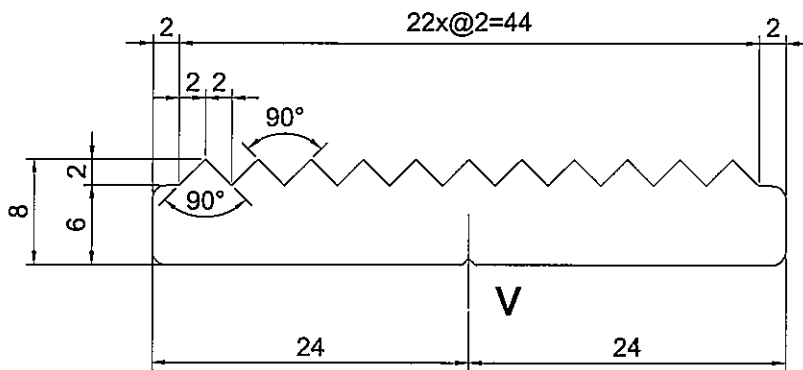

SCALE 2:1

美特鋁質有限公司	
承認圖面	<i>[Signature]</i>
日期	21/08/21

SIGNATURE GRADEING	HIGH SIGNATURE GRADEING	C.C.DIA(MM)	48.37						
AREA (SQ MM)	330.89	UNSPECIFIED THICKNESS	-	PERIMETER (MM)	124.92	STANDARD		SCALE	1:1
MASS (KG/M)	0.897	UNSPECIFIED CORNERS	-	SURFACE AREA	-	ALLOY	6061-T6	VERSION	A
COMPANY ISSUE			DRAWN	LHR	DATE	2021-07-26	APELLATION	PAGE OF	
			STANDARDIZATION		DATE		美特鋁質有限公司 MIDI Aluminium Fabricator Ltd		
			TO SIGN		DATE				
			AUDITING		DATE				
MARKER	MODIFY FILE NO	SIGNATURE	DATE	APPROV		DATE			

C.W 水櫃

CUSTOMER	CUSTOMER APPROVAL	CUST PART NO.	AL-CW-B07(0)
		SECTION NO.	X86002

a=0.1r
 b=0.2r
 c=0.3r
 d=0.4r
 e=0.5r
 f=0.8r
 g=1.0r
 h=3.0r

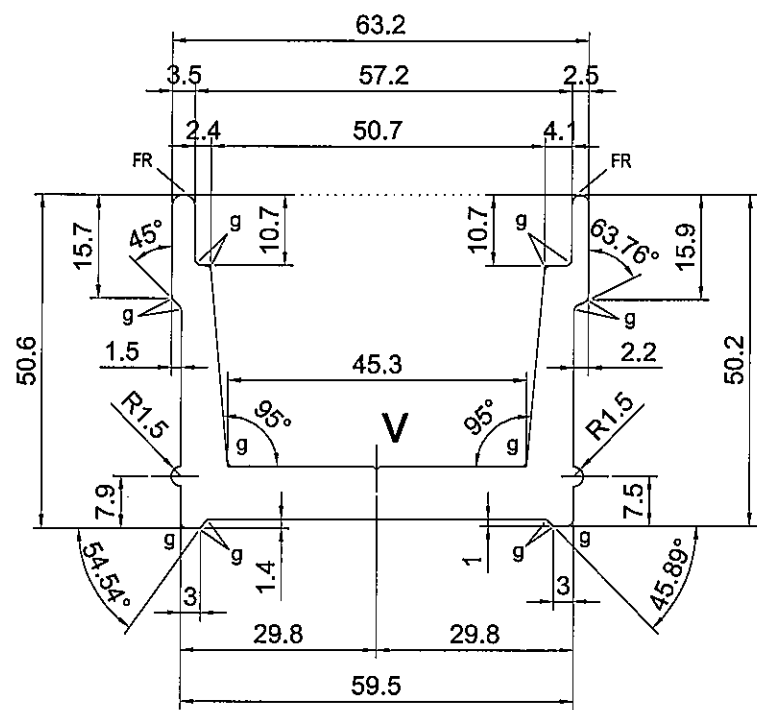

美特鋁質有限公司	
承認圖面	<i>[Signature]</i>
日期	3/08/21

SIGNATURE GRADEING	HIGH SIGNATURE GRADEING	C.C.DIA(MM)	78.91						
AREA (SQ MM)	925.32	UNSPECIFIED THICKNESS	-	PERIMETER (MM)	301.54	STANDARD		SCALE	1:1
MASS (KG/M)	2.508	UNSPECIFIED CORNERS	-	SURFACE AREA	-	ALLOY	6061-T6	VERSION	
COMPANY ISSUE			DRAWN	LHR	DATE	2021-08-28	APELLATION	PAGE OF	
			STANDARDIZATION		DATE		 美特鋁質有限公司 MIDI Aluminium Fabricator Ltd		
			TO SIGN		DATE				
			AUDITING		DATE				
MARKER	MODIFY	FILE NO	SIGNATURE	DATE	APPROV	DATE			