



工程指示 / 要求簡箋(E.I.)

工程指示編號：EI/3567/21

修改版次：

工程編號：J-853

工程名稱：大窩坪(廷坪路)

工程項目：70 窗開模

收件人：Maggie 姐

發件人：大明

日期：24/06/2021

要求提供 / 確認 事項：

- | | | |
|------------------------------------|-------------------------------------|-------------------------------|
| <input type="checkbox"/> 初步鋁料 B.M. | <input type="checkbox"/> 加工拆圖，然後生產 | <input type="checkbox"/> 尺寸表 |
| <input type="checkbox"/> 正式鋁料 B.M. | <input type="checkbox"/> 技術上資料 / 指示 | <input type="checkbox"/> 報 |
| <input type="checkbox"/> 配件 B.M. | <input type="checkbox"/> 樣辦或貨品說明書 | <input type="checkbox"/> 分判合約 |
| <input type="checkbox"/> 其他：_____ | | |

內容：

煩請 按圖紙開劃模圖 X85946 ~ X85963

請在 05/07/2021 前完成上列要求。

附有關圖紙 / 文件：附 B.M 表 0 頁,圖紙 8 頁

以上項目為:

- 原合約工程包 原合約工程加 / 減賬 新工程報價

原因：-

分發東莞各部門：

- ()生產技術總監 連附件 ()技術部 連附件 ()生產部 連附件 ()機械設計部 連附件
 ()採購部 連附件 ()生產統籌部 連附件
 ()質檢部 連附件 ()會計部 連附件 ()報關組 連附件 ()其他 未決 連附件

分發香港各部門：

- ()行政部 連附件 ()會計部 連附件 ()統籌部 連附件 ()工程部地盤科文 連附件
 ()採購部 連附件 ()QS 部 連附件 ()維修部 連附件 ()其他 _____ 連附件

傳遞編號：

發件人簽署：

項目經理簽署：

| | | | |
|----------|-------------------|---------------|--------|
| CUSTOMER | CUSTOMER APPROVAL | CUST PART NO. | AW-01 |
| | | SECTION NO. | X85946 |

生頂框

$a=0.1r$
 $b=0.2r$
 $c=0.3r$
 $d=0.4r$
 $e=0.5r$
 $f=0.8r$
 $g=1.0r$
 $h=1.5r$
 $j=2r$

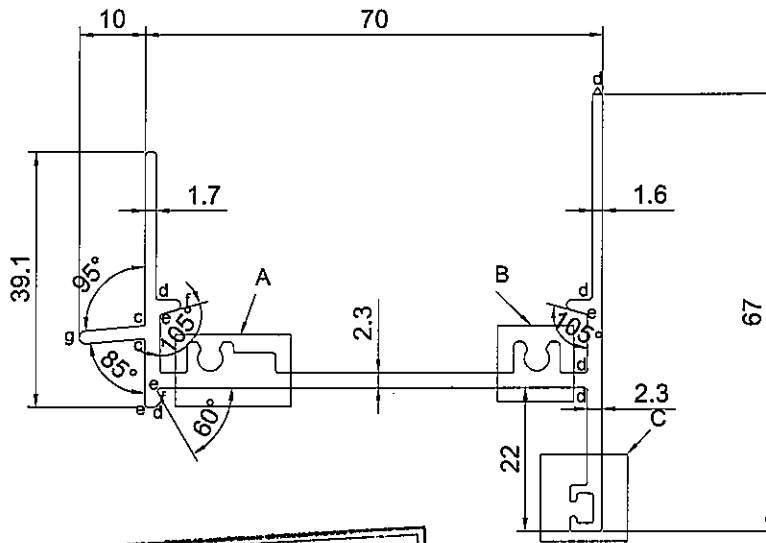
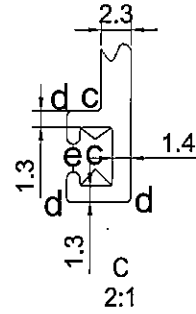
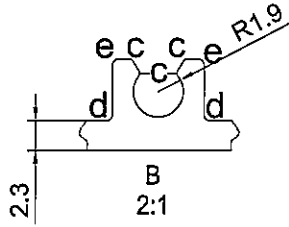
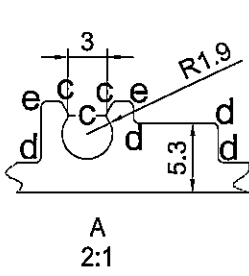

美特鋁質有限公司
 承認圖面
 日期 24/06/21

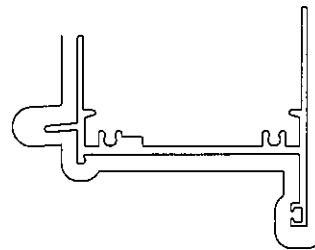

V.F

SCALE 1:2

| | | | | | | | | | |
|--------------------|-------------------------|-----------------------|-----------------|----------------|--------|------------|-------------|---------|-----|
| SIGNATURE GRADEING | HIGH SIGNATURE GRADEING | C.C.DIA(MM) | | SCALE 1:2 | | | | | |
| AREA (SQ MM) | 450.8 | UNSPECIFIED THICKNESS | 2.3 | PERIMETER (MM) | 421.5 | STANDARD | | SCALE | 1:1 |
| MASS (KG/M) | 1.253 | UNSPECIFIED CORNERS | - | SURFACE AREA | 234.97 | ALLOY | 6063-T5 | VERSION | |
| COMPANY ISSUE | | | DRAWN | L | DATE | 2021-06-22 | APPELLATION | PAGE OF | |
| | | | STANDARDIZATION | | DATE | | | | |
| | | | TO SIGN | | DATE | | | | |
| | | | AUDITING | | DATE | | | | |
| MARKER | MODIFY | FILE NO | SIGNATURE | DATE | APPROV | | DATE | | |

 美特鋁質有限公司
 MIDI Aluminium Fabricator Ltd.

| | | | |
|----------|-------------------|---------------|--------|
| CUSTOMER | CUSTOMER APPROVAL | CUST PART NO. | AW-02 |
| | | SECTION NO. | X85947 |

生底框

$a=0.1r$
 $b=0.2r$
 $c=0.3r$
 $d=0.4r$
 $e=0.5r$
 $f=0.8r$
 $g=1.0r$
 $h=1.5r$
 $j=2r$

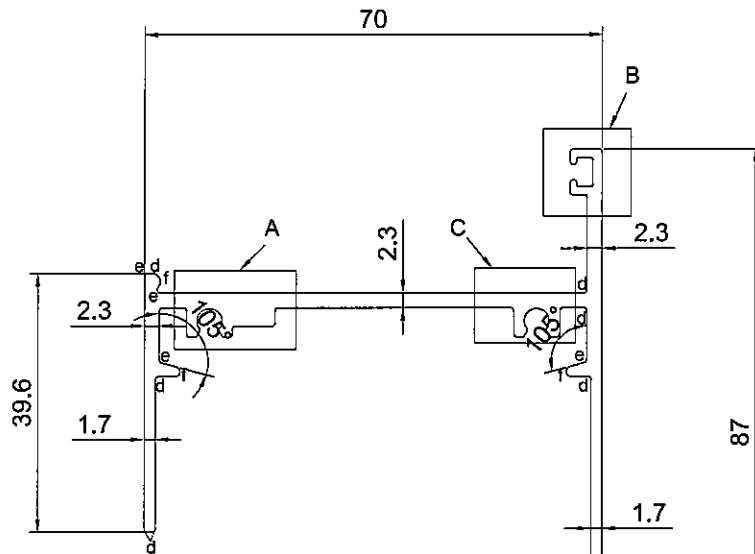
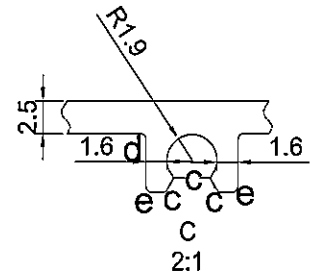
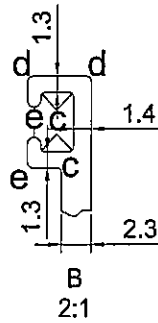
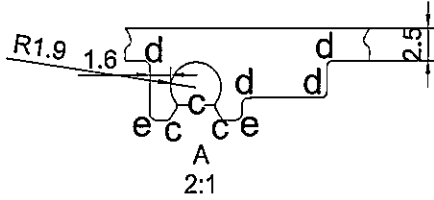

| | |
|----------|----------|
| 美特鋁質有限公司 | |
| 承認圖面 | |
| 日期 | 24/06/21 |

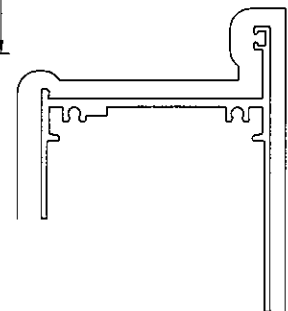

SCALE 1:2 V.F

| | | | | | | | | | |
|--------------------|-------------------------|-----------------------|-----------------|----------------|--------|------------|-------------|---------|-----|
| SIGNATURE GRADEING | HIGH SIGNATURE GRADEING | C.C.DIA(MM) | | | | | | | |
| AREA (SQ MM) | 477.3 | UNSPECIFIED THICKNESS | 2.3 | PERIMETER (MM) | 442.1 | STANDARD | | SCALE | 1:1 |
| MASS (KG/M) | 1.327 | UNSPECIFIED CORNERS | - | SURFACE AREA | 237.08 | ALLOY | 6063-T5 | VERSION | |
| COMPANY ISSUE | | | DRAWN | L | DATE | 2021-06-22 | APPELLATION | PAGE OF | |
| | | | STANDARDIZATION | | DATE | | | | |
| | | | TO SIGN | | DATE | | | | |
| | | | AUDITING | | DATE | | | | |
| MARKER | MODIFY | FILE NO | SIGNATURE | DATE | APPROV | | | | |

美特鋁質有限公司
 MIDI Aluminium Fabricator Ltd.

| | | | |
|----------|-------------------|---------------|--------|
| CUSTOMER | CUSTOMER APPROVAL | CUST PART NO. | AW-03 |
| | | SECTION NO. | X85948 |

生邊框

$a=0.1r$
 $b=0.2r$
 $c=0.3r$
 $d=0.4r$
 $e=0.5r$
 $f=0.8r$
 $g=1.0r$
 $h=1.5r$
 $j=2r$

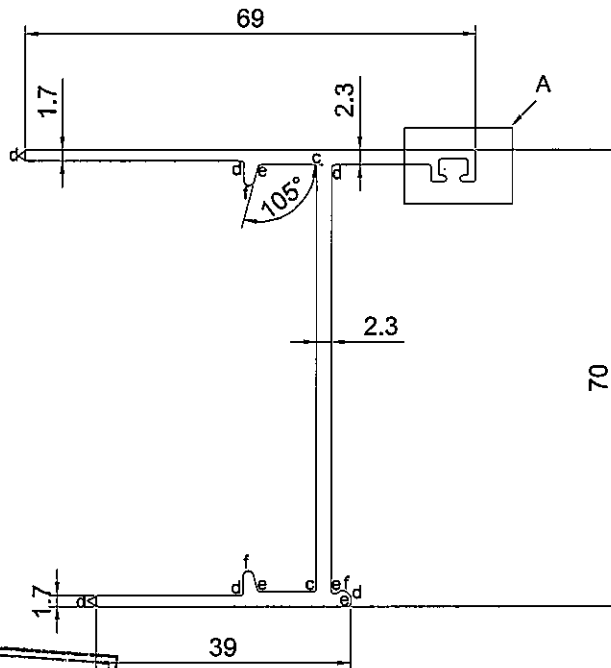
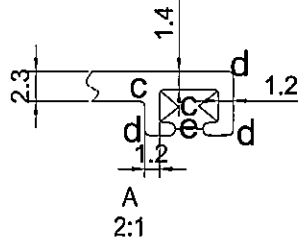

| | |
|----------|---------|
| 美特鋁質有限公司 | |
| 承認圖面 | |
| 日期 | 24/6/21 |

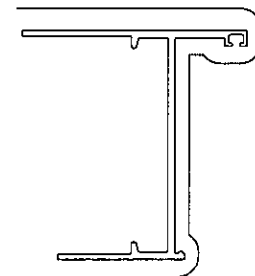

SCALE 1:2 V.F

| | | | | | | | | | |
|--------------------|-------------------------|-----------------------|-----------------|----------------|--------|------------|------------|---------|-----|
| SIGNATURE GRADEING | HIGH SIGNATURE GRADEING | C.C.DIA(MM) | | | | | | | |
| AREA (SQ MM) | 380.4 | UNSPECIFIED THICKNESS | 2.3 | PERIMETER (MM) | 374.7 | STANDARD | | SCALE | 1:1 |
| MASS (KG/M) | 1.057 | UNSPECIFIED CORNERS | - | SURFACE AREA | 217.90 | ALLOY | 6063-T5 | VERSION | |
| COMPANY ISSUE | | | DRAWN | L | DATE | 2021-06-22 | APELLATION | PAGE OF | |
| | | | STANDARDIZATION | | DATE | | | | |
| | | | TO SIGN | | DATE | | | | |
| | | | AUDITING | | DATE | | | | |
| MARKER | MODIFY | FILE NO | SIGNATURE | DATE | APPROV | | | | |

美特鋁質有限公司
 MIDI Aluminium Fabricator Ltd.

| | | | |
|----------|-------------------|---------------|--------|
| CUSTOMER | CUSTOMER APPROVAL | CUST PART NO. | AW-04 |
| | | SECTION NO. | X85949 |

生頂框

a=0.1r
b=0.2r
c=0.3r
d=0.4r
e=0.5r
f=0.8r
g=1.0r
h=1.5r
j=2r

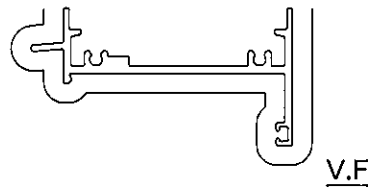
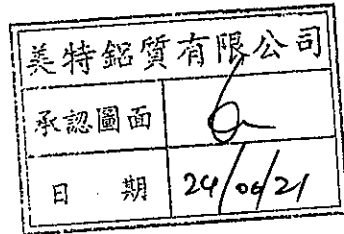
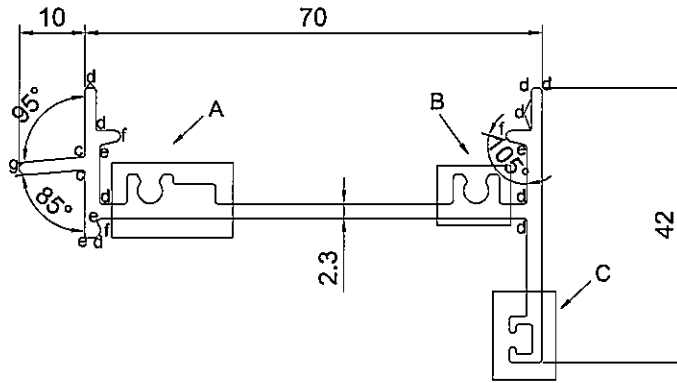
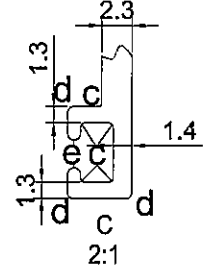
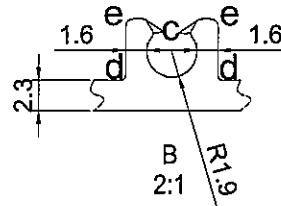
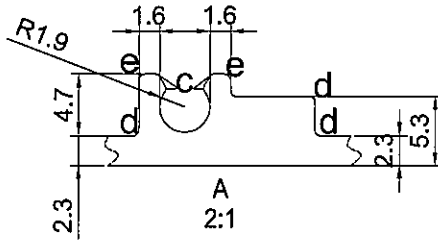

SCALE 1:2

| | | | | | | | | | |
|--------------------|-------------------------|-----------------------|-----------------|----------------|--------|------------|-------------|---------|-----|
| SIGNATURE GRADEING | HIGH SIGNATURE GRADEING | C.C.DIA(MM) | | | | | | | |
| AREA (SQ MM) | 386.4 | UNSPECIFIED THICKNESS | 2.3 | PERIMETER (MM) | 342.6 | STANDARD | | SCALE | 1:1 |
| MASS (KG/M) | 1.074 | UNSPECIFIED CORNERS | - | SURFACE AREA | 193.90 | ALLOY | 6063-T5 | VERSION | |
| COMPANY ISSUE | | | DRAWN | L | DATE | 2021-06-22 | APPELLATION | PAGE OF | |
| | | | STANDARDIZATION | | DATE | | | | |
| | | | TO SIGN | | DATE | | | | |
| | | | AUDITING | | DATE | | | | |
| MARKER | MODIFY | FILE NO | SIGNATURE | DATE | APPROV | | | | |

美特鋁質有限公司
MIDI Aluminium Fabricator Ltd.

| | | | |
|----------|-------------------|---------------|--------|
| CUSTOMER | CUSTOMER APPROVAL | CUST PART NO. | AW-05 |
| | | SECTION NO. | X85950 |

生底框

$a=0.1r$
 $b=0.2r$
 $c=0.3r$
 $d=0.4r$
 $e=0.5r$
 $f=0.8r$
 $g=1.0r$
 $h=1.5r$
 $j=2r$

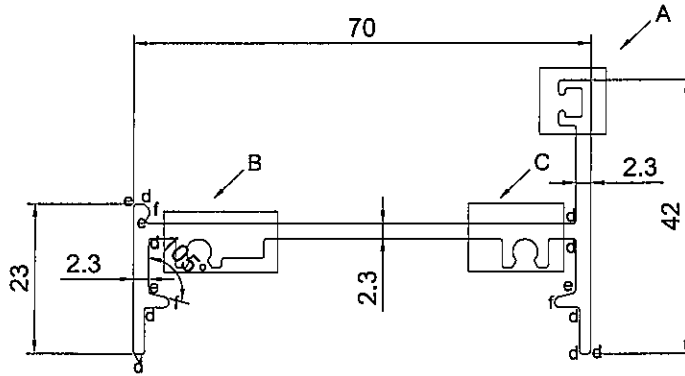
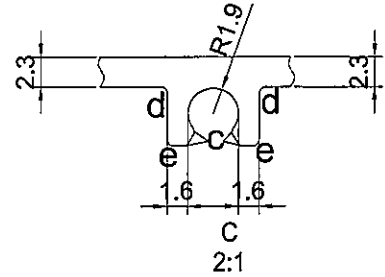
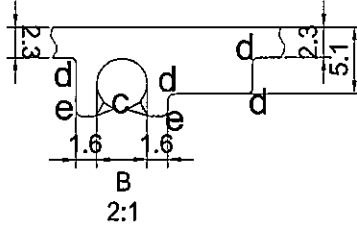
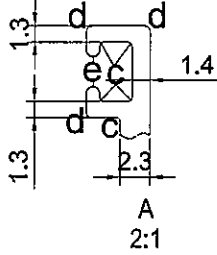

| | |
|----------|----------|
| 美特鋁質有限公司 | |
| 承認圖面 | |
| 日期 | 24/06/21 |

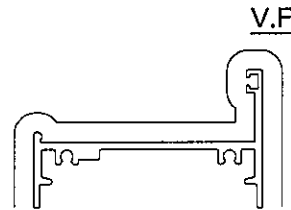

SCALE 1:2

| | | | | | | | | | |
|--------------------|-------------------------|-----------------------|-----------------|----------------|--------|------------|-------------|---------|-----|
| SIGNATURE GRADEING | HIGH SIGNATURE GRADEING | C.C.DIA(MM) | | | | | | | |
| AREA (SQ MM) | 362.3 | UNSPECIFIED THICKNESS | 2.3 | PERIMETER (MM) | 322.3 | STANDARD | | SCALE | 1:1 |
| MASS (KG/M) | 1.007 | UNSPECIFIED CORNERS | - | SURFACE AREA | 174.55 | ALLOY | 6063-T5 | VERSION | |
| COMPANY ISSUE | | | DRAWN | L | DATE | 2021-06-22 | APPELLATION | PAGE OF | |
| | | | STANDARDIZATION | | DATE | | | | |
| | | | TO SIGN | | DATE | | | | |
| | | | AUDITING | | DATE | | | | |
| MARKER | MODIFY | FILE NO | SIGNATURE | DATE | APPROV | | | | |

美特鋁質有限公司
 MIDI Aluminium Fabricator Ltd.

| | | | |
|----------|-------------------|---------------|--------|
| CUSTOMER | CUSTOMER APPROVAL | CUST PART NO. | AW-06 |
| | | SECTION NO. | X85951 |

生邊框

$a=0.1r$
 $b=0.2r$
 $c=0.3r$
 $d=0.4r$
 $e=0.5r$
 $f=0.8r$
 $g=1.0r$
 $h=1.5r$
 $j=2r$

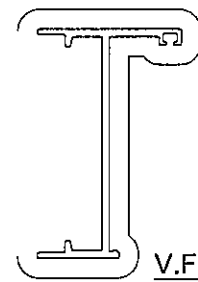
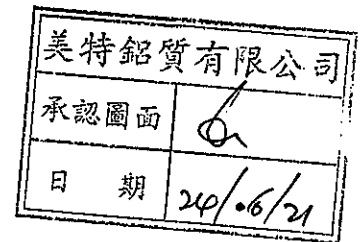
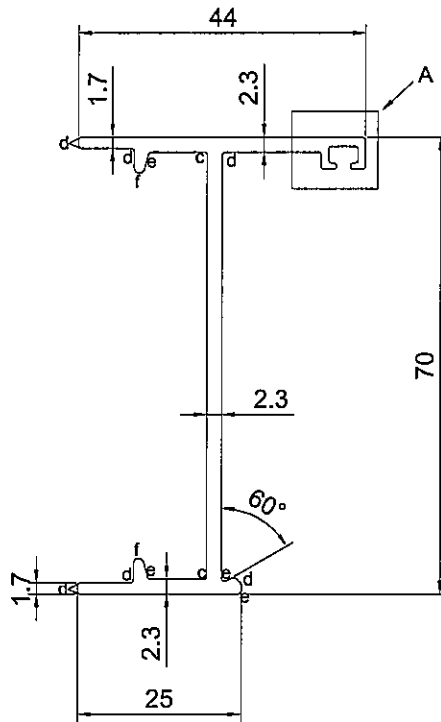
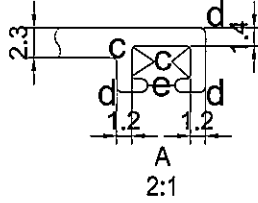

SCALE 1:2

| | | | | | | | | | |
|--------------------|-------------------------|-----------------------|-----------------|----------------|------------|-------------|---------|---------|-----|
| SIGNATURE GRADEING | HIGH SIGNATURE GRADEING | C.C.DIA(MM) | | | | | | | |
| AREA (SQ MM) | 316.9 | UNSPECIFIED THICKNESS | 2.3 | PERIMETER (MM) | 299.7 | STANDARD | | SCALE | 1:1 |
| MASS (KG/M) | 0.881 | UNSPECIFIED CORNERS | - | SURFACE AREA | 178.95 | ALLOY | 6063-T5 | VERSION | |
| COMPANY ISSUE | | | DRAWN | L | 2021-06-22 | APPELLATION | | PAGE OF | |
| | | | STANDARDIZATION | | DATE | | | | |
| | | | TO SIGN | | DATE | | | | |
| | | | AUDITING | | DATE | | | | |
| MARKER | MODIFY | FILE NO | SIGNATURE | DATE | APPROV | | | | |

美特鋁質有限公司
 MIDI Aluminium Fabricator Ltd.

| | | | |
|----------|-------------------|---------------|--------|
| CUSTOMER | CUSTOMER APPROVAL | CUST PART NO. | AW-07 |
| | | SECTION NO. | X85952 |

生窗玉

$a=0.1r$
 $b=0.2r$
 $c=0.3r$
 $d=0.4r$
 $e=0.5r$
 $f=0.8r$
 $g=1.0r$
 $h=1.5r$
 $j=2r$

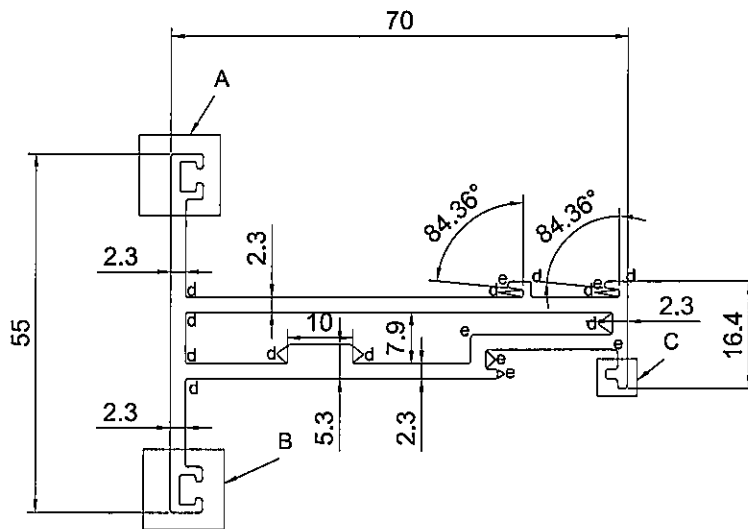
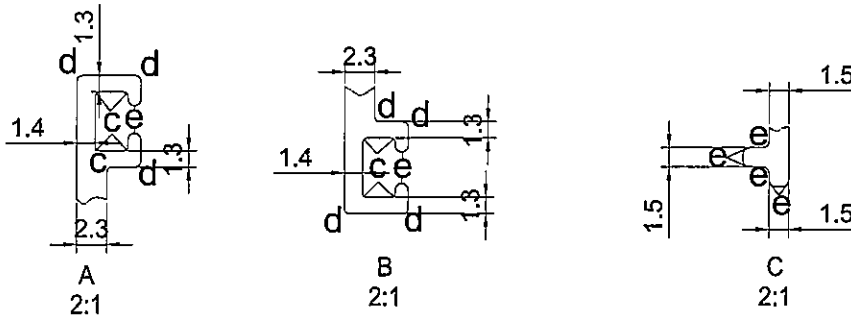

| | |
|----------|----------|
| 美特鋁質有限公司 | |
| 承認圖面 | |
| 日期 | 24/06/21 |

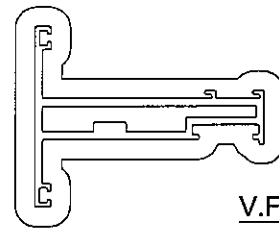

SCALE 1:2

| | | | | | | | | | |
|--------------------|-------------------------|-----------------------|-----------------|----------------|--------|------------|-------------|---------|-----|
| SIGNATURE GRADEING | HIGH SIGNATURE GRADEING | C.C.DIA(MM) | | | | | | | |
| AREA (SQ MM) | 519.6 | UNSPECIFIED THICKNESS | 2.3 | PERIMETER (MM) | 464.2 | STANDARD | | SCALE | 1:1 |
| MASS (KG/M) | 1.445 | UNSPECIFIED CORNERS | - | SURFACE AREA | 309.29 | ALLOY | 6063-T5 | VERSION | |
| COMPANY ISSUE | | | DRAWN | L | DATE | 2021-06-22 | APPELLATION | PAGE OF | |
| | | | STANDARDIZATION | | DATE | | | | |
| | | | TO SIGN | | DATE | | | | |
| | | | AUDITING | | DATE | | | | |
| MARKER | MODIFY | FILE NO | SIGNATURE | DATE | APPROV | | | | |

美特鋁質有限公司
 MIDI Aluminium Fabricator Ltd.

| | | | |
|----------|-------------------|---------------|--------|
| CUSTOMER | CUSTOMER APPROVAL | CUST PART NO. | AW-08 |
| | | SECTION NO. | X85953 |

企工字

$a=0.1r$
 $b=0.2r$
 $c=0.3r$
 $d=0.4r$
 $e=0.5r$
 $f=0.8r$
 $g=1.0r$
 $h=1.5r$
 $j=2r$

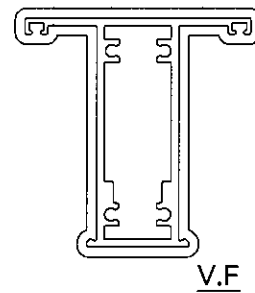
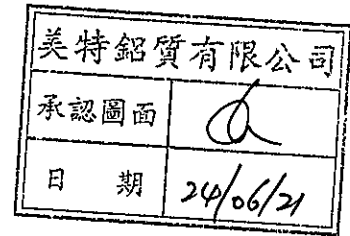
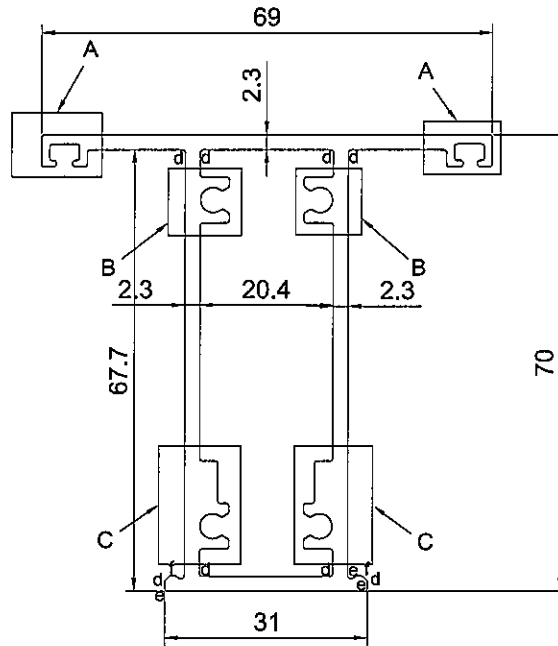
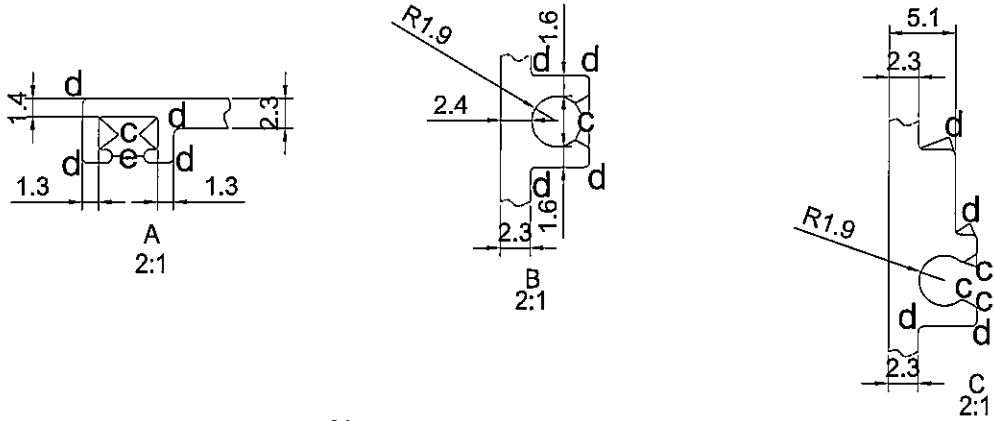

SCALE 1:2

| | | | | | | | | | |
|--------------------|-------------------------|-----------------------|-----------------|----------------|--------|------------|-------------|---------|-----|
| SIGNATURE GRADEING | HIGH SIGNATURE GRADEING | C.C.DIA(MM) | | | | | | | |
| AREA (SQ MM) | 645.2 | UNSPECIFIED THICKNESS | 2.3 | PERIMETER (MM) | 552.1 | STANDARD | | SCALE | 1:1 |
| MASS (KG/M) | 1.794 | UNSPECIFIED CORNERS | - | SURFACE AREA | 318.31 | ALLOY | 6063-T5 | VERSION | |
| COMPANY ISSUE | | | DRAWN | L | DATE | 2021-06-22 | APPELLATION | PAGE OF | |
| | | | STANDARDIZATION | | DATE | | | | |
| | | | TO SIGN | | DATE | | | | |
| | | | AUDITING | | DATE | | | | |
| MARKER | MODIFY | FILE NO | SIGNATURE | DATE | APPROV | | | | |

美特鋁質有限公司
 MIDI Aluminium Fabricator Ltd.

| | | | |
|----------|-------------------|---------------|--------|
| CUSTOMER | CUSTOMER APPROVAL | CUST PART NO. | AW-09 |
| | | SECTION NO. | X85954 |

上生下生

$a=0.1r$
 $b=0.2r$
 $c=0.3r$
 $d=0.4r$
 $e=0.5r$
 $f=0.8r$
 $g=1.0r$
 $h=1.5r$
 $j=2r$

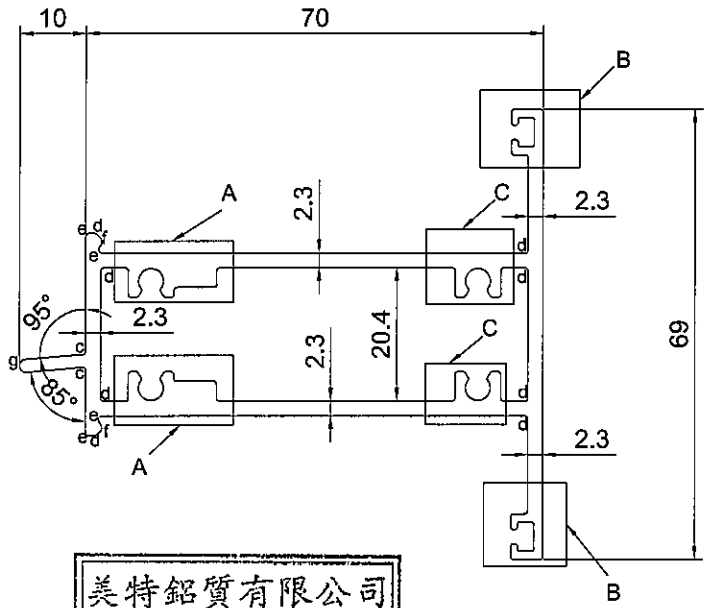
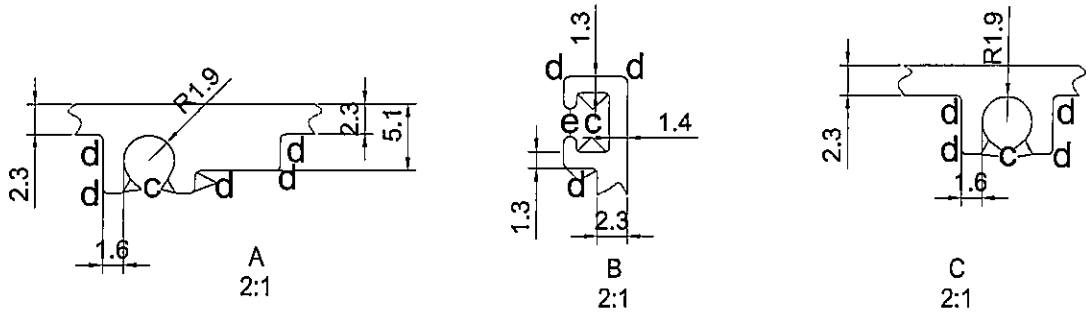

| | |
|----------|--------------------|
| 美特鋁質有限公司 | |
| 承認圖面 | <i>[Signature]</i> |
| 日期 | 24/06/21 |

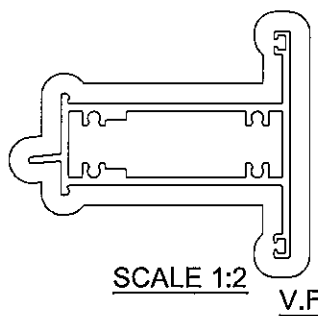

| | | | | | | | | | |
|--------------------|-------------------------|-----------------------|-----------------|----------------|--------|------------|-------------|---------|-----|
| SIGNATURE GRADEING | HIGH SIGNATURE GRADEING | C.C.DIA(MM) | | | | | | | |
| AREA (SQ MM) | 663.7 | UNSPECIFIED THICKNESS | 2.3 | PERIMETER (MM) | 571.3 | STANDARD | | SCALE | 1:1 |
| MASS (KG/M) | 1.845 | UNSPECIFIED CORNERS | - | SURFACE AREA | 337.86 | ALLOY | 6063-T5 | VERSION | |
| COMPANY ISSUE | | | DRAWN | L | DATE | 2021-06-22 | APPELLATION | PAGE OF | |
| | | | STANDARDIZATION | | DATE | | | | |
| | | | TO SIGN | | DATE | | | | |
| | | | AUDITING | | DATE | | | | |
| MARKER | MODIFY | FILE NO | SIGNATURE | DATE | APPROV | DATE | | | |

美特鋁質有限公司
 MIDI Aluminium Fabricator Ltd.

| | | | |
|----------|-------------------|---------------|--------|
| CUSTOMER | CUSTOMER APPROVAL | CUST PART NO. | AW-10 |
| | | SECTION NO. | X85955 |

上生下梗中橫

$a=0.1r$
 $b=0.2r$
 $c=0.3r$
 $d=0.4r$
 $e=0.5r$
 $f=0.8r$
 $g=1.0r$
 $h=1.5r$
 $j=2r$

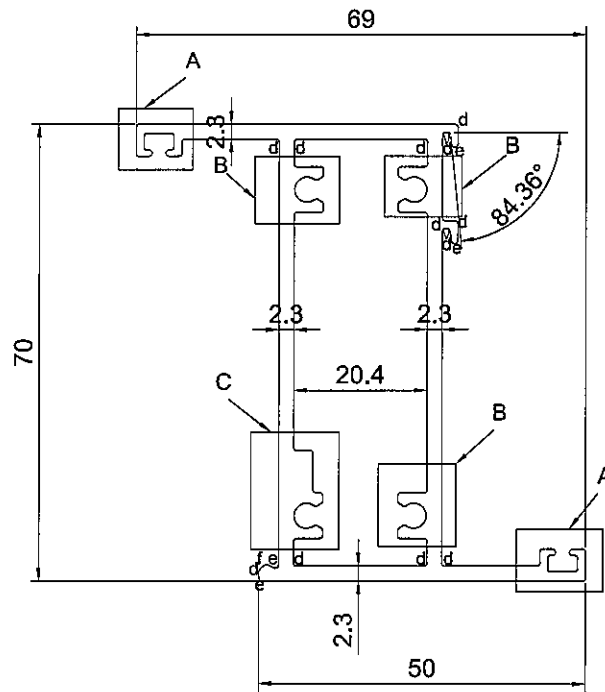
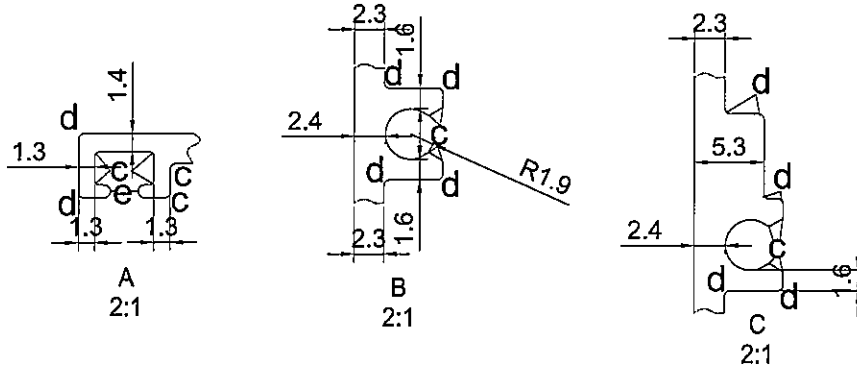

| | |
|----------|----------|
| 美特鋁質有限公司 | |
| 承認圖面 | |
| 日期 | 24/06/21 |

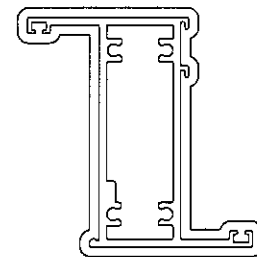

SCALE 1:2 V.F

| | | | | | | | | | |
|--------------------|-------------------------|-----------------------|-----------------|----------------|--------|------------|------------|---------|-----|
| SIGNATURE GRADEING | HIGH SIGNATURE GRADEING | C.C.DIA(MM) | | | | | | | |
| AREA (SQ MM) | 631.6 | UNSPECIFIED THICKNESS | 2.3 | PERIMETER (MM) | 563.8 | STANDARD | | SCALE | 1:1 |
| MASS (KG/M) | 1.756 | UNSPECIFIED CORNERS | - | SURFACE AREA | 329.68 | ALLOY | 6063-T5 | VERSION | |
| COMPANY ISSUE | | | DRAWN | L | DATE | 2021-06-22 | APELLATION | PAGE OF | |
| | | | STANDARDIZATION | | DATE | | | | |
| | | | TO SIGN | | DATE | | | | |
| | | | AUDITING | | DATE | | | | |
| MARKER | MODIFY | FILE NO | SIGNATURE | DATE | APPROV | | DATE | | |

美特鋁質有限公司
 MIDI Aluminium Fabricator Ltd.

| | | | |
|----------|-------------------|---------------|--------|
| CUSTOMER | CUSTOMER APPROVAL | CUST PART NO. | AW-11 |
| | | SECTION NO. | X85956 |

反拍線

a=0.1r
b=0.2r
c=0.3r
d=0.4r
e=0.5r
f=0.8r
g=1.0r
h=1.5r
j=2r

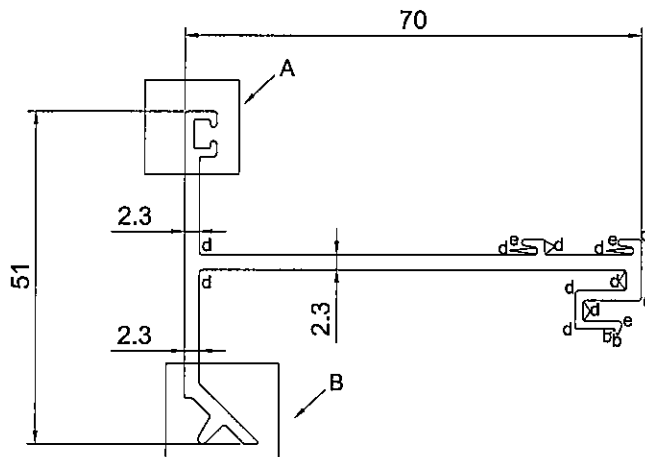
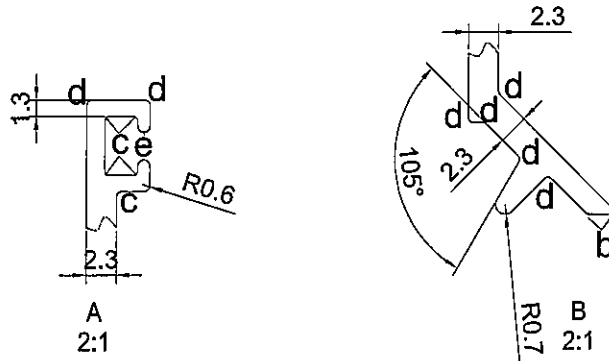

| | |
|----------|----------|
| 美特鋁質有限公司 | |
| 承認圖面 | |
| 日期 | 24/06/21 |

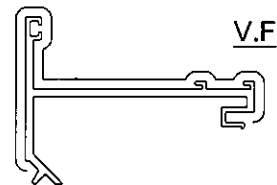

SCALE 1:2

| | | | | | | | | | |
|--------------------|-------------------------|-----------------------|-----------------|----------------|--------|------------|-------------|---------|-----|
| SIGNATURE GRADEING | HIGH SIGNATURE GRADEING | C.C.DIA(MM) | | | | | | | |
| AREA (SQ MM) | 337.8 | UNSPECIFIED THICKNESS | 2.3 | PERIMETER (MM) | 333.1 | STANDARD | | SCALE | 1:1 |
| MASS (KG/M) | 0.939 | UNSPECIFIED CORNERS | - | SURFACE AREA | 174.67 | ALLOY | 6063-T5 | VERSION | |
| COMPANY ISSUE | | | DRAWN | L | DATE | 2021-06-22 | APPELLATION | PAGE OF | |
| | | | STANDARDIZATION | | DATE | | | | |
| | | | TO SIGN | | DATE | | | | |
| | | | AUDITING | | DATE | | | | |
| MARKER | MODIFY | FILE NO | SIGNATURE | DATE | APPROV | | | | |

美特鋁質有限公司
MIDI Aluminium Fabricator Ltd.

18

| | | | |
|----------|-------------------|---------------|--------|
| CUSTOMER | CUSTOMER APPROVAL | CUST PART NO. | AW-12 |
| | | SECTION NO. | X85957 |

玻璃線

$a=0.1r$
 $b=0.2r$
 $c=0.3r$
 $d=0.4r$
 $e=0.5r$
 $f=0.8r$
 $g=1.0r$
 $h=1.5r$
 $j=2r$

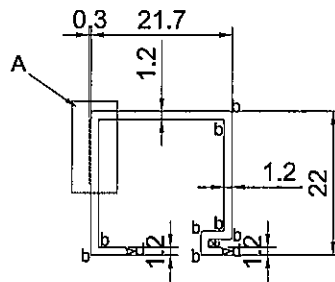
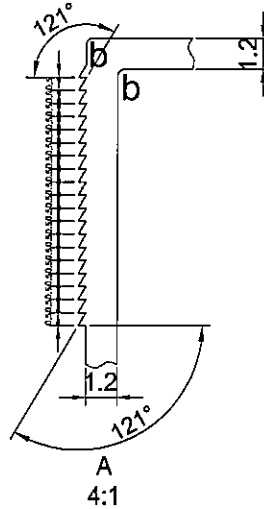

| | |
|----------|----------|
| 美特鋁質有限公司 | |
| 承認圖面 | |
| 日期 | 24/06/21 |

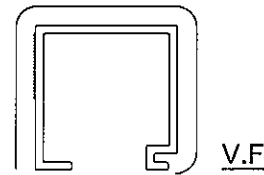

SCALE 1:1

| | | | | | | | | | |
|--------------------|-------------------------|-----------------------|-----------------|----------------|--------|------------|-------------|---------|-----|
| SIGNATURE GRADEING | HIGH SIGNATURE GRADEING | C.C.DIA(MM) | | | | | | | |
| AREA (SQ MM) | 89.5 | UNSPECIFIED THICKNESS | 1.2 | PERIMETER (MM) | 155.2 | STANDARD | | SCALE | 1:1 |
| MASS (KG/M) | 0.248 | UNSPECIFIED CORNERS | - | SURFACE AREA | 84.47 | ALLOY | 6063-T5 | VERSION | |
| COMPANY ISSUE | | | DRAWN | L | DATE | 2021-06-22 | APPELLATION | PAGE OF | |
| | | | STANDARDIZATION | | DATE | | | | |
| | | | TO SIGN | | DATE | | | | |
| | | | AUDITING | | DATE | | | | |
| MARKER | MODIFY | FILE NO | SIGNATURE | DATE | APPROV | | | | |

美特鋁質有限公司
 MIDI Aluminium Fabricator Ltd.

| | | | | | |
|----------|--|-------------------|--|---------------|--------|
| CUSTOMER | | CUSTOMER APPROVAL | | CUST PART NO. | AW-13 |
| | | | | SECTION NO. | X85958 |

百葉玉

$a=0.1r$
 $b=0.2r$
 $c=0.3r$
 $d=0.4r$
 $e=0.5r$
 $f=0.8r$
 $g=1.0r$
 $h=1.5r$
 $j=2r$

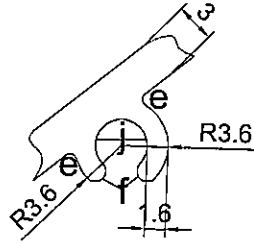

A
2:1

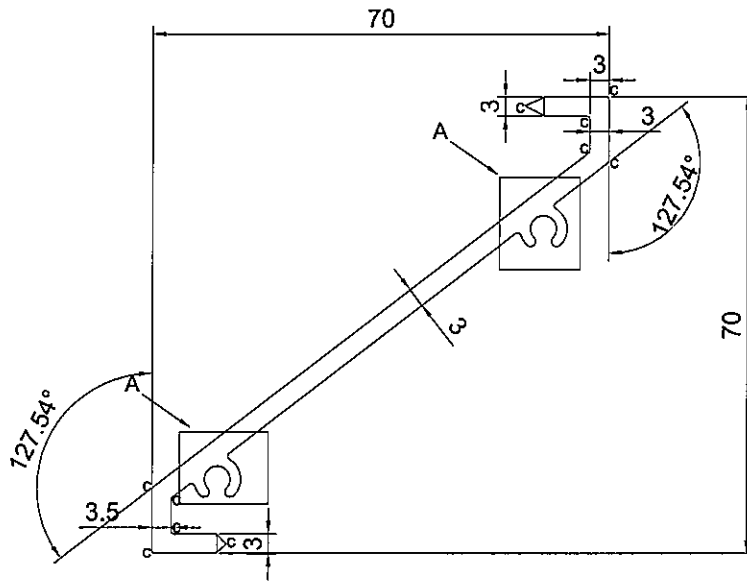

| | |
|----------|----------|
| 美特鋁質有限公司 | |
| 承認圖面 | |
| 日期 | 24/06/21 |

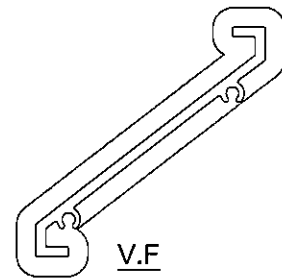

SCALE 1:2

| | | | | | | | | | |
|--------------------|-------------------------|-----------------------|-----------------|----------------|--------|------------|-------------|---------|-----|
| SIGNATURE GRADEING | HIGH SIGNATURE GRADEING | C.C.DIA(MM) | | | | | | | |
| AREA (SQ MM) | 384.1 | UNSPECIFIED THICKNESS | 3 | PERIMETER (MM) | 272.9 | STANDARD | | SCALE | 1:1 |
| MASS (KG/M) | 1.068 | UNSPECIFIED CORNERS | - | SURFACE AREA | 272.91 | ALLOY | 6063-T5 | VERSION | |
| COMPANY ISSUE | | | DRAWN | L | DATE | 2021-06-22 | APPELLATION | PAGE OF | |
| | | | STANDARDIZATION | | DATE | | | | |
| | | | TO SIGN | | DATE | | | | |
| | | | AUDITING | | DATE | | | | |
| MARKER | MODIFY | FILE NO | SIGNATURE | DATE | APPROV | | DATE | | |

美特鋁質有限公司
 MIDI Aluminium Fabricator Ltd.

| | | | | | |
|----------|--|-------------------|--|---------------|--------|
| CUSTOMER | | CUSTOMER APPROVAL | | CUST PART NO. | AW-14 |
| | | | | SECTION NO. | X85959 |

角碼

- a=0.1r
- b=0.2r
- c=0.3r
- d=0.4r
- e=0.5r
- f=0.8r
- g=1.0r
- h=1.5r
- j=2r

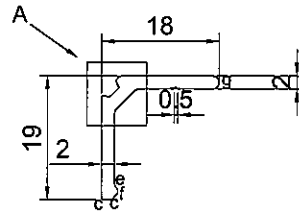
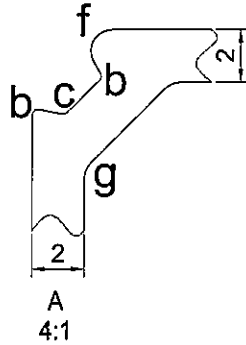

| | |
|----------|----------|
| 美特鋁質有限公司 | |
| 承認圖面 | |
| 日期 | 24/06/21 |

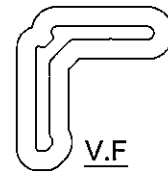

SCALE 1:1

| | | | | | | | | | |
|--------------------|-------------------------|-----------------------|-----------------|----------------|--------|------------|------------|---------|-----|
| SIGNATURE GRADEING | HIGH SIGNATURE GRADEING | C.C.DIA(MM) | | SCALE 1:1 | | | | | |
| AREA (SQ MM) | 68.5 | UNSPECIFIED THICKNESS | 2 | PERIMETER (MM) | 70.6 | STANDARD | | SCALE | 1:1 |
| MASS (KG/M) | 0.190 | UNSPECIFIED CORNERS | - | SURFACE AREA | 70.6 | ALLOY | 6063-T5 | VERSION | |
| COMPANY ISSUE | | | DRAWN | L | DATE | 2021-06-22 | APELLATION | PAGE OF | |
| | | | STANDARDIZATION | | DATE | | | | |
| | | | TO SIGN | | DATE | | | | |
| | | | AUDITING | | DATE | | | | |
| MARKER | MODIFY | FILE NO | SIGNATURE | DATE | APPROV | DATE | | | |

| | | | |
|----------|-------------------|---------------|--------|
| CUSTOMER | CUSTOMER APPROVAL | CUST PART NO. | AW-15 |
| | | SECTION NO. | X85960 |

梗邊框

a=0.1r
b=0.2r
c=0.3r
d=0.4r
e=0.5r
f=0.8r
g=1.0r
h=1.5r
j=2r

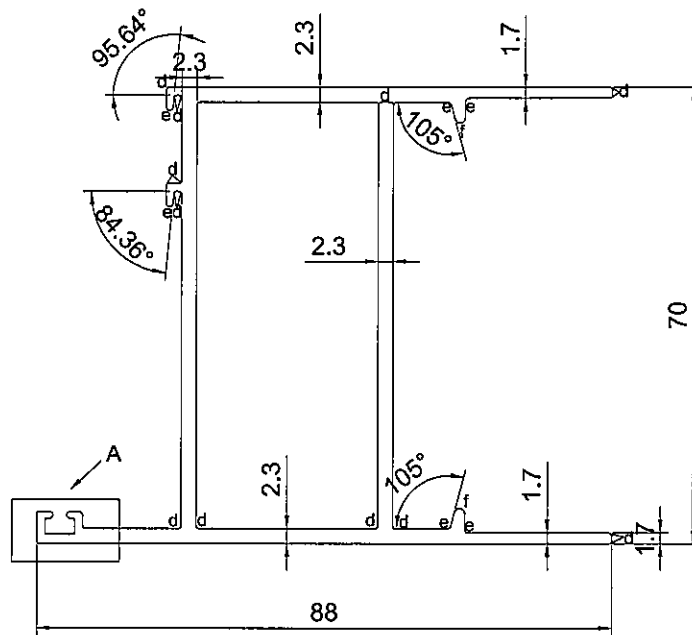
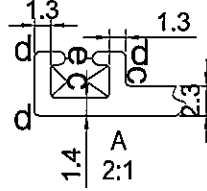

| | |
|----------|----------|
| 美特鋁質有限公司 | |
| 承認圖面 | |
| 日期 | 24/06/21 |

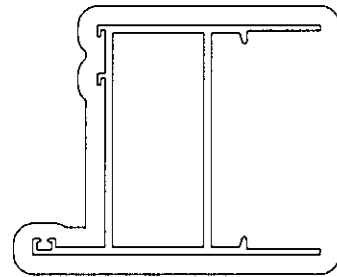

V.F

SCALE 1:2

| | | | | | | | | | |
|--------------------|-------------------------|-----------------------|-----------------|----------------|--------|------------|------------|---------|-----|
| SIGNATURE GRADEING | HIGH SIGNATURE GRADEING | C.C.DIA(MM) | | | | | | | |
| AREA (SQ MM) | 651.6 | UNSPECIFIED THICKNESS | 2.3 | PERIMETER (MM) | 603.5 | STANDARD | | SCALE | 1:1 |
| MASS (KG/M) | 1.812 | UNSPECIFIED CORNERS | - | SURFACE AREA | 272.48 | ALLOY | 6063-T5 | VERSION | |
| COMPANY ISSUE | | | DRAWN | L | DATE | 2021-06-22 | APELLATION | PAGE OF | |
| | | | STANDARDIZATION | | DATE | | | | |
| | | | TO SIGN | | DATE | | | | |
| | | | AUDITING | | DATE | | | | |
| MARKER | MODIFY | FILE NO | SIGNATURE | DATE | APPROV | | | | |

美特鋁質有限公司
MIDI Aluminium Fabricator Ltd.

| | | | |
|----------|-------------------|---------------|--------|
| CUSTOMER | CUSTOMER APPROVAL | CUST PART NO. | AW-16 |
| | | SECTION NO. | X85961 |

生框夾企

a=0.1r
b=0.2r
c=0.3r
d=0.4r
e=0.5r
f=0.8r
g=1.0r
h=1.5r
j=2r

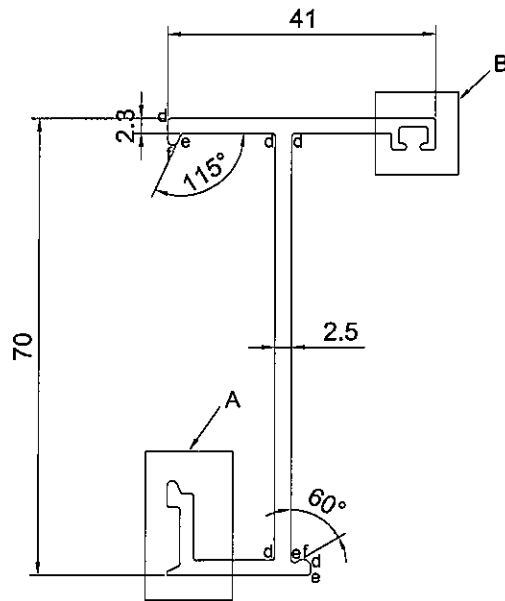
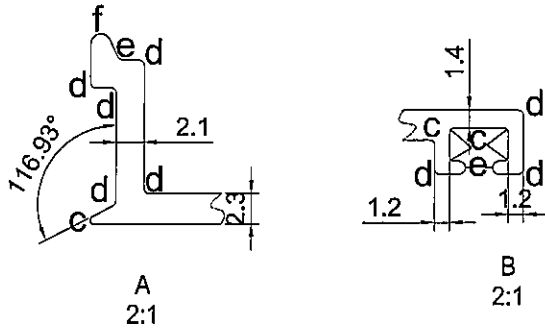

美特鋁質有限公司
承認圖面
日期 24/06/21

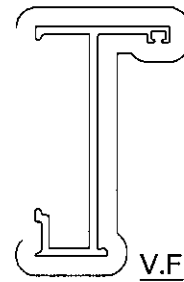

SCALE 1:2

| | | | | | | | | | |
|--------------------|-------------------------|-----------------------|-----------------|----------------|--------|------------|-------------|---------|-----|
| SIGNATURE GRADEING | HIGH SIGNATURE GRADEING | C.C.DIA(MM) | | | | | | | |
| AREA (SQ MM) | 341.5 | UNSPECIFIED THICKNESS | 2.3 | PERIMETER (MM) | 302.9 | STANDARD | | SCALE | 1:1 |
| MASS (KG/M) | 0.949 | UNSPECIFIED CORNERS | - | SURFACE AREA | 175.48 | ALLOY | 6063-T5 | VERSION | |
| COMPANY ISSUE | | | DRAWN | L | DATE | 2021-06-22 | APPELLATION | PAGE OF | |
| | | | STANDARDIZATION | | DATE | | | | |
| | | | TO SIGN | | DATE | | | | |
| | | | AUDITING | | DATE | | | | |
| MARKER | MODIFY | FILE NO | SIGNATURE | DATE | APPROV | | | | |

美特鋁質有限公司
MIDI Aluminium Fabricator Ltd.

1/6

| | | | |
|----------|-------------------|---------------|--------|
| CUSTOMER | CUSTOMER APPROVAL | CUST PART NO. | AW-17 |
| | | SECTION NO. | X85962 |

生框夾企

$a=0.1r$
 $b=0.2r$
 $c=0.3r$
 $d=0.4r$
 $e=0.5r$
 $f=0.8r$
 $g=1.0r$
 $h=1.5r$
 $j=2r$

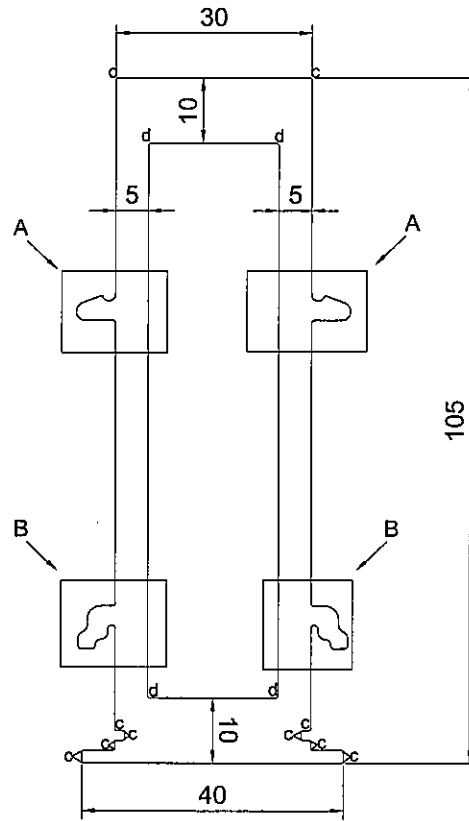
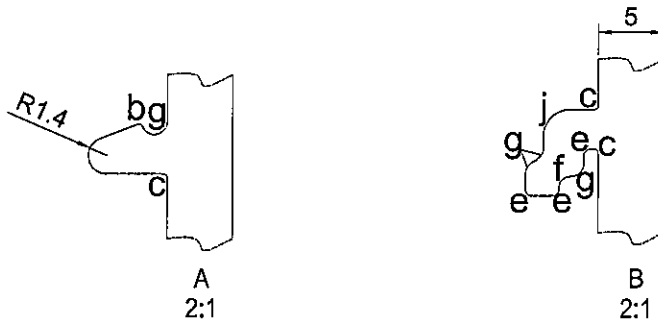

| | |
|----------|----------|
| 美特鋁質有限公司 | |
| 承認圖面 | |
| 日期 | 24/06/21 |

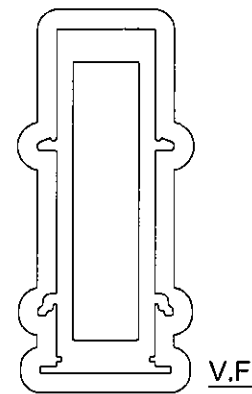

SCALE 1:2

| | | | | | | | | | |
|--------------------|-------------------------|-----------------------|-----------|----------------|------------|-------------|---------|---------|-----|
| SIGNATURE GRADEING | HIGH SIGNATURE GRADEING | C.C.DIA(MM) | | | | | | | |
| AREA (SQ MM) | 1549.6 | UNSPECIFIED THICKNESS | 5 | PERIMETER (MM) | 554.5 | STANDARD | | SCALE | 1:1 |
| MASS (KG/M) | 4.309 | UNSPECIFIED CORNERS | - | SURFACE AREA | 345.20 | ALLOY | 6063-T5 | VERSION | |
| COMPANY ISSUE | | DRAWN | L | DATE | 2021-06-22 | APPELLATION | | PAGE OF | |
| | | STANDARDIZATION | | DATE | | | | | |
| | | TO SIGN | | DATE | | | | | |
| | | AUDITING | | DATE | | | | | |
| MARKER | MODIFY | FILE NO | SIGNATURE | DATE | APPROV | | | | |

美特鋁質有限公司
 MIDI Aluminium Fabricator Ltd.

| | | | |
|----------|-------------------|---------------|--------|
| CUSTOMER | CUSTOMER APPROVAL | CUST PART NO. | AW-18 |
| | | SECTION NO. | X85963 |

轉角企通

- a=0.1r
- b=0.2r
- c=0.3r
- d=0.4r
- e=0.5r
- f=0.8r
- g=1.0r
- h=1.5r
- j=2r

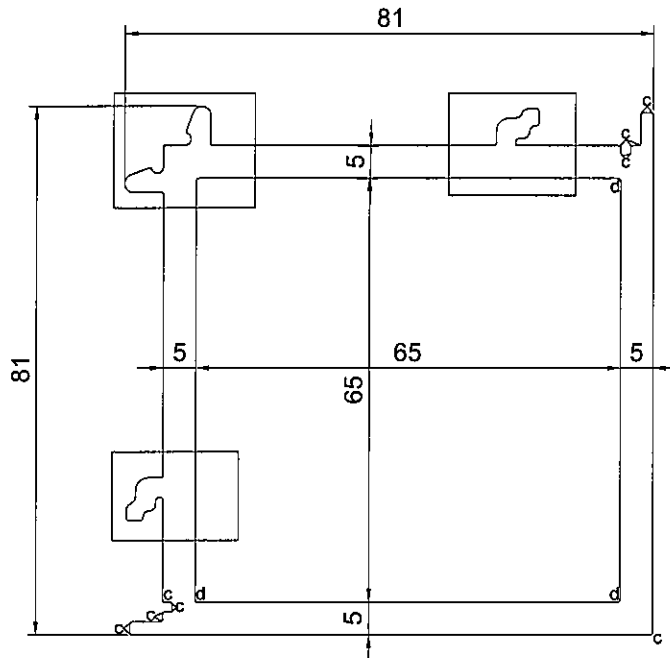
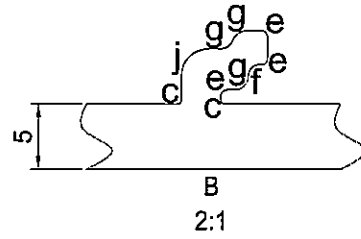
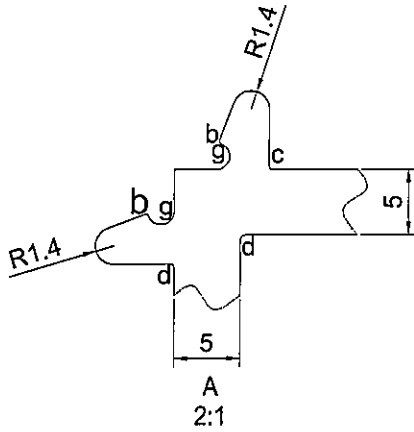

| | |
|----------|----------|
| 美特鋁質有限公司 | |
| 承認圖面 | |
| 日期 | 24/06/21 |

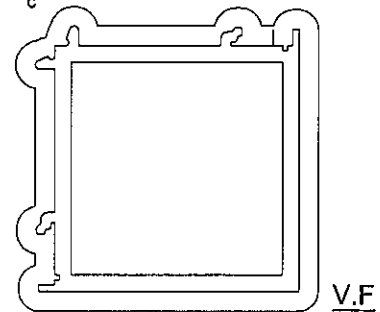

SCALE 1:2

| | | | | | | | | |
|--------------------|-------------------------|-----------------------|-----------------|----------------|--------|------------|------------|-----------|
| SIGNATURE GRADEING | HIGH SIGNATURE GRADEING | C.C.DIA(MM) | | | | | | |
| AREA (SQ MM) | 1499.6 | UNSPECIFIED THICKNESS | 5 | PERIMETER (MM) | 634.6 | STANDARD | | SCALE 1:1 |
| MASS (KG/M) | 4.170 | UNSPECIFIED CORNERS | - | SURFACE AREA | 375.29 | ALLOY | 6063-T6 | VERSION |
| COMPANY ISSUE | | | DRAWN | L | DATE | 2021-06-22 | APELLATION | PAGE OF |
| | | | STANDARDIZATION | | DATE | | | |
| | | | TO SIGN | | DATE | | | |
| | | | AUDITING | | DATE | | | |
| MARKER | MODIFY | FILE NO | SIGNATURE | DATE | APPROV | | | |

美特鋁質有限公司
MIDI Aluminium Fabricator Ltd.