

工程指示 / 要求簡箋 ENGINEER INSTRUCTIONS(E.I.)

工程指示編號:	EI- 8019	修改版本:	-
	HK- /		
工程編號:	J 853	工程名稱:	延坪道
收件人:	Maggie Lor	發件人:	Joe Chan
工程項目:	Row D 花園欄河地 盤用鐵件 (綠色)	日期:	8/7/2024

<input type="checkbox"/> 原合約工程包	<input type="checkbox"/> 原合約工程加 / 減賬 QT-	<input type="checkbox"/> 新工程報價 QT-
---------------------------------	--	------------------------------------

信件批核號碼/圖紙參考編號:	批核模具圖紙編號:
客戶指示附件:	管理內部批簽署:

<input type="checkbox"/> 初步鋁料 B.M.	<input type="checkbox"/> 加工拆圖, 然後生產	<input type="checkbox"/> 尺寸表
<input type="checkbox"/> 正式鋁料 B.M.	<input type="checkbox"/> 技術上資料/指示	<input type="checkbox"/> 報價
<input type="checkbox"/> 配件 B.M.	<input type="checkbox"/> 樣辦或貨品說明書	<input type="checkbox"/> 分判合約
<input type="checkbox"/> 其他:		



內容: 請依附件資料, 生產 GMS 鐵件, 遠地盤。  
- 請分層包裝出貨。  
(此 EI 不需驗牌)。  
完成上列要求日期: 25/7/2024

國內

<input type="checkbox"/> 生產技術總監	<input type="checkbox"/> 連附件	<input type="checkbox"/> 技術部	<input type="checkbox"/> 連附件	<input type="checkbox"/> 生產部	<input type="checkbox"/> 連附件
<input type="checkbox"/> 採購部	<input type="checkbox"/> 連附件	<input type="checkbox"/> 生產統籌部	<input type="checkbox"/> 連附件	<input type="checkbox"/> 報關組	<input type="checkbox"/> 連附件
<input type="checkbox"/> 質檢部	<input type="checkbox"/> 連附件	<input type="checkbox"/> 會計部	<input type="checkbox"/> 連附件	<input type="checkbox"/> 機械設計部	<input type="checkbox"/> 連附件
<input type="checkbox"/> 香港辦	<input type="checkbox"/> 連附件	<input type="checkbox"/> 其他:			

香港

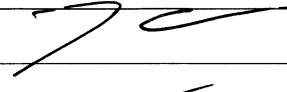
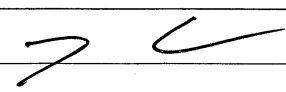
<input type="checkbox"/> 行政部	<input type="checkbox"/> 連附件	<input type="checkbox"/> 會計部	<input type="checkbox"/> 連附件	<input type="checkbox"/> 統籌部	<input type="checkbox"/> 連附件	<input type="checkbox"/> 工程部	<input type="checkbox"/> 連附件
<input type="checkbox"/> 採購部	<input type="checkbox"/> 連附件	<input type="checkbox"/> QS部	<input type="checkbox"/> 連附件	<input checked="" type="checkbox"/> 地盤管理	<input checked="" type="checkbox"/> 連附件	<input type="checkbox"/> 維修部	<input type="checkbox"/> 連附件

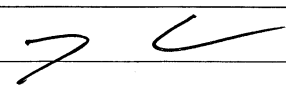
\*發件人簽署:  \*組別成員批核簽署:   
傳遞編號:  項目經理簽署: 

# J853-香港延坪道(第二期別墅)-Glass Balustrade-ROW D花园拦河地盤用铁件分栋数量统计表

工程: J853-香港延坪道(第二期別墅)

日期: 5-Jul-24

序号	部件图编号							总数量	备注
		HD1	HD2	HD3	HD5	HD6	HD7		
1	J853-GB-ST-801	14	12	12	8	20	10	76	
2	J853-GB-ST-802	1	1			1	1	4	
3	J853-GB-ST-813			1				1	
4	J853-GB-ST-846A	1						1	
5	J853-GB-ST-846B	5						5	
6	J853-GB-ST-846C	1						1	
7	J853-GB-ST-846D		1					1	
8	J853-GB-ST-846E		4					4	
9	J853-GB-ST-846F		1					1	
10	J853-GB-ST-846G			1				1	
11	J853-GB-ST-846H			4			3	7	
12	J853-GB-ST-846J			1				1	
13	J853-GB-ST-846K				1			1	
14	J853-GB-ST-846L				2			2	
15	J853-GB-ST-846M				1			1	
16	J853-GB-ST-846N					1		1	
17	J853-GB-ST-846P					2		2	
18	J853-GB-ST-846Q					1		1	
19	J853-GB-ST-846R					1		1	
20	J853-GB-ST-846S					1		1	
21	J853-GB-ST-846T					1		1	
22	J853-GB-ST-846U					1		1	
23	J853-GB-ST-846V					1		1	
24	J853-GB-ST-846W						1	1	
25	J853-GB-ST-846X						1	1	
26	J853-GB-ST-847					1		1	
27	J853-GB-ST-848A	1						1	
28	J853-GB-ST-848B	5						5	
29	J853-GB-ST-848C	1						1	
30	J853-GB-ST-848D		1					1	
31	J853-GB-ST-848E		4					4	
32	J853-GB-ST-848F		1					1	
33	J853-GB-ST-848G			1				1	
34	J853-GB-ST-848H			4			3	7	
35	J853-GB-ST-848J			1				1	
36	J853-GB-ST-848K				1			1	
37	J853-GB-ST-848L				2			2	
38	J853-GB-ST-848M				1			1	
39	J853-GB-ST-848N					1		1	
40	J853-GB-ST-848P					2		2	
41	J853-GB-ST-848Q					1		1	
42	J853-GB-ST-848R					2		2	
43	J853-GB-ST-848S					1		1	
44	J853-GB-ST-848T					1		1	
45	J853-GB-ST-848U					1		1	
46	J853-GB-ST-848V					1		1	
47	J853-GB-ST-848W						1	1	
48	J853-GB-ST-848X						1	1	
49	J853-GB-ST-849A	1						1	

# J853-香港延坪道(第二期別墅)-Glass Balustrade-ROW D花园拦河地盤用铁件分栋数量统计表

工程: J853-香港延坪道(第二期別墅)

日期: 5-Jul-24

序号	部件图编号							总数量	备注
		HD1	HD2	HD3	HD5	HD6	HD7		
50	J853-GB-ST-849B	5		1				6	
51	J853-GB-ST-849C	1						1	
52	J853-GB-ST-849D		1		2			3	
53	J853-GB-ST-849E		4					4	
54	J853-GB-ST-849F		1	1				2	
55	J853-GB-ST-849G			4			3	7	
56	J853-GB-ST-849H				1	1		2	
57	J853-GB-ST-849J				1			1	
58	J853-GB-ST-849K					2		2	
59	J853-GB-ST-849L					2		2	
60	J853-GB-ST-849M					1		1	
61	J853-GB-ST-849N					2		2	
62	J853-GB-ST-849P					1		1	
63	J853-GB-ST-849Q					1	1	2	
64	J853-GB-ST-849R						1	1	
65	J853-GB-ST-850A	5						5	
66	J853-GB-ST-850B		4					4	
67	J853-GB-ST-850C			4			3	7	
68	J853-GB-ST-850D				2			2	
69	J853-GB-ST-850E					1		1	
70	J853-GB-ST-850F					2		2	
71	J853-GB-ST-850G					1		1	
72	J853-GB-ST-850H					1		1	
73	J853-GB-ST-850J						1	1	
74	J853-GB-ST-851A	1						1	
75	J853-GB-ST-851B		1					1	
76	J853-GB-ST-851C			1				1	
77	J853-GB-ST-851D				1			1	
78	J853-GB-ST-851E					1		1	
79	J853-GB-ST-852A				1			1	
80	J853-GB-ST-852B					1		1	
81	J853-GB-ST-852C					1		1	
82	J853-GB-ST-852D						1	1	
83	J853-GB-ST-853A	1						1	
84	J853-GB-ST-853B		1					1	
85	J853-GB-ST-853C			1				1	
86	J853-GB-ST-854					1		1	
87	J853-GB-ST-855					1		1	
88	J853-GB-ST-873		2	2	2	2		8	
89	J853-GB-ST-875A				1	1		2	
90	J853-GB-ST-875E		1					1	
91	J853-GB-ST-875F			1				1	
92	J853-GB-ST-876A				1	1		2	
93	J853-GB-ST-876E		1					1	
94	J853-GB-ST-876F			1				1	
95	J853-GB-ST-877A				1	1		2	
96	J853-GB-ST-877E		1					1	
97	J853-GB-ST-877F			1				1	
		43	42	42	29	66	31	253	

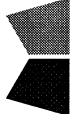
		美特鋁質有限公司		工程號:	J-853	計算:	J. L.	日期:	5/7/2024	送呈:	Joe
MIDI Aluminium Fabricator Ltd.		地盤名稱:		香港延坪道(第二期別墅)		核對:		日期:		副本:	
地盤用鐵件B.M.表		項目類別:		Gliss Blustrde-花园拦河 (Row. D)		批准:		日期:		版本:	
BM編號:		/C Code:				總重量(Kg):		1615.91			

序號	修改標示	加工圖号	鐵件編號	鐵件名稱	顏色	數量(件)			重量(Kg)		備註
						實用	後備	總數	單件	總重量	
1		J853-GB-ST-801	J853-GB-ST-801	200x10mm 铁巴	热浸锌	76		76	1.18	89.68	
2		J853-GB-ST-802	J853-GB-ST-802	40x40x5mm 铁角	热浸锌	4		4	0.22	0.88	
3		J853-GB-ST-813	J853-GB-ST-813	40x40x5mm 铁角	热浸锌	1		1	0.18	0.18	
4		J853-GB-ST-846	J853-GB-ST-846A	150x75x10mm 铁角	热浸锌	1		1	24.58	24.58	
5		J853-GB-ST-846	J853-GB-ST-846B	150x75x10mm 铁角	热浸锌	5		5	22.75	113.75	
6		J853-GB-ST-846	J853-GB-ST-846C	150x75x10mm 铁角	热浸锌	1		1	23.10	23.10	
7		J853-GB-ST-846	J853-GB-ST-846D	150x75x10mm 铁角	热浸锌	1		1	23.54	23.54	
8		J853-GB-ST-846	J853-GB-ST-846E	150x75x10mm 铁角	热浸锌	4		4	21.22	84.88	
9		J853-GB-ST-846	J853-GB-ST-846F	150x75x10mm 铁角	热浸锌	1		1	23.71	23.71	
10		J853-GB-ST-846	J853-GB-ST-846G	150x75x10mm 铁角	热浸锌	1		1	22.11	22.11	
11		J853-GB-ST-846	J853-GB-ST-846H	150x75x10mm 铁角	热浸锌	7		7	21.49	150.43	
12		J853-GB-ST-846	J853-GB-ST-846J	150x75x10mm 铁角	热浸锌	1		1	23.62	23.62	
13		J853-GB-ST-846	J853-GB-ST-846K	150x75x10mm 铁角	热浸锌	1		1	25.42	25.42	
14		J853-GB-ST-846	J853-GB-ST-846L	150x75x10mm 铁角	热浸锌	2		2	23.57	47.14	
15		J853-GB-ST-846	J853-GB-ST-846M	150x75x10mm 铁角	热浸锌	1		1	25.19	25.19	
16		J853-GB-ST-846	J853-GB-ST-846N	150x75x10mm 铁角	热浸锌	1		1	21.78	21.78	
17		J853-GB-ST-846	J853-GB-ST-846P	150x75x10mm 铁角	热浸锌	2		2	19.74	39.48	
18		J853-GB-ST-846	J853-GB-ST-846Q	150x75x10mm 铁角	热浸锌	1		1	17.72	17.72	
19		J853-GB-ST-846	J853-GB-ST-846R	150x75x10mm 铁角	热浸锌	1		1	18.08	18.08	
20		J853-GB-ST-846	J853-GB-ST-846S	150x75x10mm 铁角	热浸锌	1		1	22.69	22.69	
21		J853-GB-ST-846	J853-GB-ST-846T	150x75x10mm 铁角	热浸锌	1		1	26.37	26.37	
22		J853-GB-ST-846	J853-GB-ST-846U	150x75x10mm 铁角	热浸锌	1		1	21.78	21.78	
23		J853-GB-ST-846	J853-GB-ST-846V	150x75x10mm 铁角	热浸锌	1		1	23.39	23.39	
24		J853-GB-ST-846	J853-GB-ST-846W	150x75x10mm 铁角	热浸锌	1		1	23.49	23.49	
25		J853-GB-ST-846	J853-GB-ST-846X	150x75x10mm 铁角	热浸锌	1		1	22.12	22.12	
26		J853-GB-ST-847	J853-GB-ST-847	150x75x10mm 铁角	热浸锌	1		1	17.35	17.35	

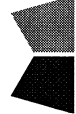
		美特鋁質有限公司		工程號:	J-853	計算:	J. L.	日期:	5/7/2024	送呈:	Joe
MIDI Aluminium Fabricator Ltd.		地盤名稱:		香港延坪道(第二期別墅)		核對:		日期:		副本:	
地盤用鐵件B.M.表		項目類別:		Gliss Blustrde-花园拦河 (Row. D)		批准:		日期:		版本:	
BM編號:		/C Code:				總重量(Kg):		1615.91			

序號	修改標示	加工圖号	鐵件編號	鐵件名稱	顏色	數量(件)			重量(Kg)		備註
						實用	後備	總數	單件	總重量	
27		J853-GB-ST-848	J853-GB-ST-848A	50x34x6mm 鐵角	熱浸鋅	1		1	5.43	5.43	
28		J853-GB-ST-848	J853-GB-ST-848B	50x34x6mm 鐵角	熱浸鋅	5		5	5.03	25.15	
29		J853-GB-ST-848	J853-GB-ST-848C	50x34x6mm 鐵角	熱浸鋅	1		1	5.29	5.29	
30		J853-GB-ST-848	J853-GB-ST-848D	50x34x6mm 鐵角	熱浸鋅	1		1	5.20	5.20	
31		J853-GB-ST-848	J853-GB-ST-848E	50x34x6mm 鐵角	熱浸鋅	4		4	4.69	18.76	
32		J853-GB-ST-848	J853-GB-ST-848F	50x34x6mm 鐵角	熱浸鋅	1		1	5.24	5.24	
33		J853-GB-ST-848	J853-GB-ST-848G	50x34x6mm 鐵角	熱浸鋅	1		1	5.04	5.04	
34		J853-GB-ST-848	J853-GB-ST-848H	50x34x6mm 鐵角	熱浸鋅	7		7	4.75	33.25	
35		J853-GB-ST-848	J853-GB-ST-848J	50x34x6mm 鐵角	熱浸鋅	1		1	5.22	5.22	
36		J853-GB-ST-848	J853-GB-ST-848K	50x34x6mm 鐵角	熱浸鋅	1		1	5.62	5.62	
37		J853-GB-ST-848	J853-GB-ST-848L	50x34x6mm 鐵角	熱浸鋅	2		2	5.21	10.42	
38		J853-GB-ST-848	J853-GB-ST-848M	50x34x6mm 鐵角	熱浸鋅	1		1	5.57	5.57	
39		J853-GB-ST-848	J853-GB-ST-848N	50x34x6mm 鐵角	熱浸鋅	1		1	4.82	4.82	
40		J853-GB-ST-848	J853-GB-ST-848P	50x34x6mm 鐵角	熱浸鋅	2		2	4.36	8.72	
41		J853-GB-ST-848	J853-GB-ST-848Q	50x34x6mm 鐵角	熱浸鋅	1		1	4.30	4.30	
42		J853-GB-ST-848	J853-GB-ST-848R	50x34x6mm 鐵角	熱浸鋅	2		2	4.00	8.00	
43		J853-GB-ST-848	J853-GB-ST-848S	50x34x6mm 鐵角	熱浸鋅	1		1	4.78	4.78	
44		J853-GB-ST-848	J853-GB-ST-848T	50x34x6mm 鐵角	熱浸鋅	1		1	5.60	5.60	
45		J853-GB-ST-848	J853-GB-ST-848U	50x34x6mm 鐵角	熱浸鋅	1		1	4.82	4.82	
46		J853-GB-ST-848	J853-GB-ST-848V	50x34x6mm 鐵角	熱浸鋅	1		1	5.17	5.17	
47		J853-GB-ST-848	J853-GB-ST-848W	50x34x6mm 鐵角	熱浸鋅	1		1	5.19	5.19	
48		J853-GB-ST-848	J853-GB-ST-848X	50x34x6mm 鐵角	熱浸鋅	1		1	4.89	4.89	
49		J853-GB-ST-849	J853-GB-ST-849A	40x25x5mm 鐵角	熱浸鋅	1		1	3.50	3.50	
50		J853-GB-ST-849	J853-GB-ST-849B	40x25x5mm 鐵角	熱浸鋅	6		6	3.24	19.44	
51		J853-GB-ST-849	J853-GB-ST-849C	40x25x5mm 鐵角	熱浸鋅	1		1	3.41	3.41	
52		J853-GB-ST-849	J853-GB-ST-849D	40x25x5mm 鐵角	熱浸鋅	3		3	3.35	10.05	

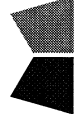
		美特鋁質有限公司		工程號:	J-853	計算:	J. L.	日期:	5/7/2024	送呈:	Joe
MIDI Aluminium Fabricator Ltd.		地盤名稱:		香港延坪道(第二期別墅)		核對:		日期:		副本:	
地盤用鐵件B.M.表		項目類別:		Gliss Blustrde-花園拦河 (Row. D)		批准:		日期:		版本:	
BM編號:		/C Code:				總重量(Kg):		1615.91			

序號	修改標示	加工圖号	鐵件編號	鐵件名稱	顏色	數量(件)			重量(Kg)		備註
						實用	後備	總數	單件	總重量	
53		J853-GB-ST-849	J853-GB-ST-849E	40x25x5mm 鐵角	热浸锌	4		4	3.02	12.08	
54		J853-GB-ST-849	J853-GB-ST-849F	40x25x5mm 鐵角	热浸锌	2		2	3.36	6.72	
55		J853-GB-ST-849	J853-GB-ST-849G	40x25x5mm 鐵角	热浸锌	7		7	3.06	21.42	
56		J853-GB-ST-849	J853-GB-ST-849H	40x25x5mm 鐵角	热浸锌	2		2	3.61	7.22	
57		J853-GB-ST-849	J853-GB-ST-849J	40x25x5mm 鐵角	热浸锌	1		1	3.58	3.58	
58		J853-GB-ST-849	J853-GB-ST-849K	40x25x5mm 鐵角	热浸锌	2		2	3.10	6.20	
59		J853-GB-ST-849	J853-GB-ST-849L	40x25x5mm 鐵角	热浸锌	2		2	2.81	5.62	
60		J853-GB-ST-849	J853-GB-ST-849M	40x25x5mm 鐵角	热浸锌	1		1	2.76	2.76	
61		J853-GB-ST-849	J853-GB-ST-849N	40x25x5mm 鐵角	热浸锌	2		2	2.57	5.14	
62		J853-GB-ST-849	J853-GB-ST-849P	40x25x5mm 鐵角	热浸锌	1		1	3.07	3.07	
63		J853-GB-ST-849	J853-GB-ST-849Q	40x25x5mm 鐵角	热浸锌	2		2	3.33	6.66	
64		J853-GB-ST-849	J853-GB-ST-849R	40x25x5mm 鐵角	热浸锌	1		1	3.15	3.15	
65		J853-GB-ST-850	J853-GB-ST-850A	100x50x6mm 鐵角	热浸锌	5		5	8.59	42.95	
66		J853-GB-ST-850	J853-GB-ST-850B	100x50x6mm 鐵角	热浸锌	4		4	7.96	31.84	
67		J853-GB-ST-850	J853-GB-ST-850C	100x50x6mm 鐵角	热浸锌	7		7	8.09	56.63	
68		J853-GB-ST-850	J853-GB-ST-850D	100x50x6mm 鐵角	热浸锌	2		2	8.91	17.82	
69		J853-GB-ST-850	J853-GB-ST-850E	100x50x6mm 鐵角	热浸锌	1		1	6.53	6.53	
70		J853-GB-ST-850	J853-GB-ST-850F	100x50x6mm 鐵角	热浸锌	2		2	7.36	14.72	
71		J853-GB-ST-850	J853-GB-ST-850G	100x50x6mm 鐵角	热浸锌	1		1	6.70	6.70	
72		J853-GB-ST-850	J853-GB-ST-850H	100x50x6mm 鐵角	热浸锌	1		1	8.19	8.19	
73		J853-GB-ST-850	J853-GB-ST-850J	100x50x6mm 鐵角	热浸锌	1		1	7.21	7.21	
74		J853-GB-ST-851	J853-GB-ST-851A	100x50x6mm 鐵角	热浸锌	1		1	9.61	9.61	
75		J853-GB-ST-851	J853-GB-ST-851B	100x50x6mm 鐵角	热浸锌	1		1	8.94	8.94	
76		J853-GB-ST-851	J853-GB-ST-851C	100x50x6mm 鐵角	热浸锌	1		1	9.05	9.05	
77		J853-GB-ST-851	J853-GB-ST-851D	100x50x6mm 鐵角	热浸锌	1		1	9.94	9.94	
78		J853-GB-ST-851	J853-GB-ST-851E	100x50x6mm 鐵角	热浸锌	1		1	8.72	8.72	





美特铝质有限公司  
MIDI Aluminium Fabricator Ltd.

版本号		采用	工厂	地盘	√	名称	铁件加工图	批准	-	-	数量	256
日期		颜色	热浸锌	材料	200x10mm 铁巴	单件重量(kg)	1.18	长度	75	宽度	-	
工程号	J853	制图	J.L.	05/6/24	物料号	J853-GB-ST-801	复核	-	-	图号	J853-GB-ST-801	
地盘	香港延坪路											

位置	数量
HB1	22
HB2	14
HB3	6
HB5	22
HB6	16
HB7	14
HB8	10
总数	104

位置	数量
HC1	26
HC2	12
HC3	6
HC5	20
HC6	12
总数	76

位置	数量
HD1	14
HD2	12
HD3	12
HD5	8
HD6	20
HD7	10
总数	76

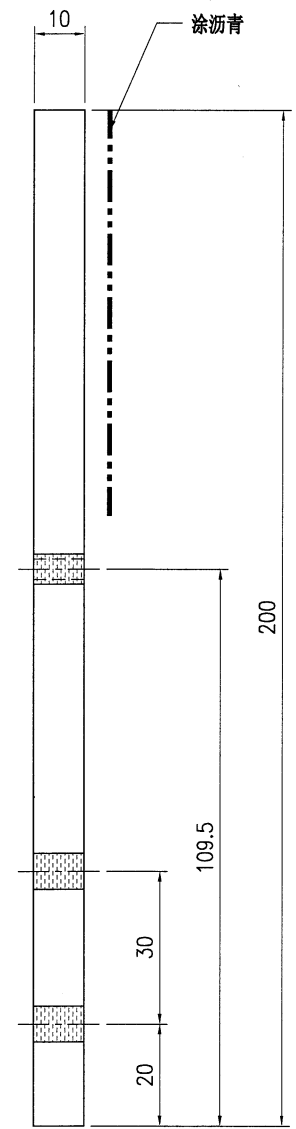
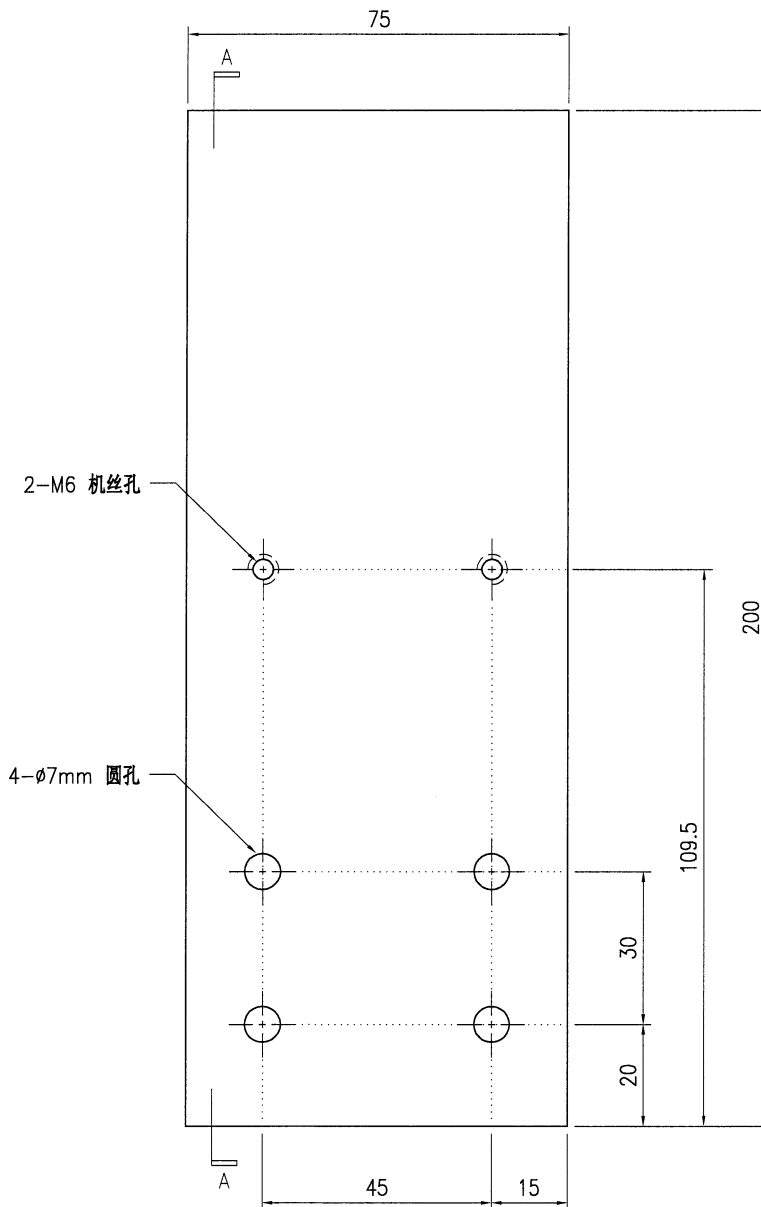
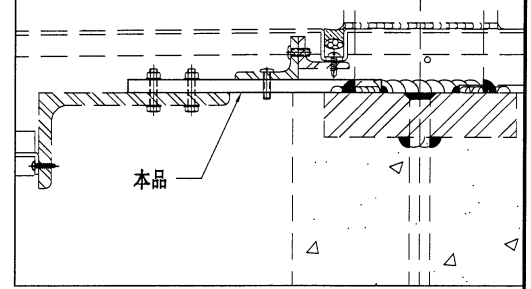

SECTION A-A

技术说明:

1. 所需材料为: 铁件; 等级为: S275;
2. 外形尺寸允许偏差为 $\pm 0.5$ mm, 角度的允许偏差为 $\pm 0.5^\circ$ ; 孔位的允许偏差为 $\pm 0.5$ mm, 孔距的允许偏差为 $\pm 0.5$ mm, 累计偏差为 $\pm 0.5$ mm;
3. 槽口、豁口的长宽边允许偏差为 $+0.5$ mm, 中心线允许偏差都为 $\pm 0.5$ mm;
4. \* \* 为重要尺寸, 加工过程中要保证此尺寸, 加工完毕须标示代号。



美特铝质有限公司  
MIDI Aluminium Fabricator Ltd.

工程号	J853	制图	J.L.	05/6/24	物料号	J853-GB-ST-802	
地盘	香港延坪路	复核	-	-	图号	J853-GB-ST-802	
名称	铁件加工图	批准	-	-	数量	15	
材料	40x40x5mm 铁角	单件重量(kg)	0.22	长度	75	宽度	-

版本		采用	工厂		地盘	√
日期		颜色	热浸锌			

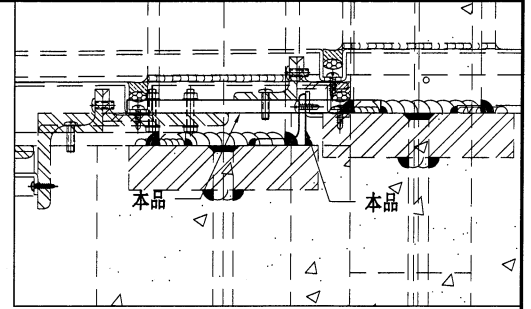

位置	数量
HB1	1
HB2	
HB3	
HB5	1
HB6	1
HB7	
HB8	1
总数	4

位置	数量
HC1	4
HC2	1
HC3	
HC5	1
HC6	1
总数	7

位置	数量
HD1	1
HD2	1
HD3	
HD5	
HD6	1
HD7	1
总数	4

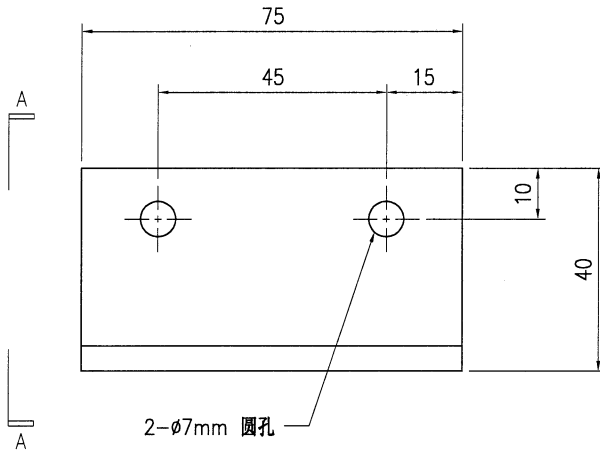

2- $\phi$ 7mm 圆孔

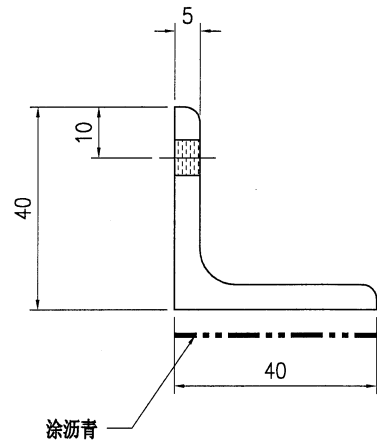

SECTION A-A

技术说明:

1. 所需材料为: 铁件; 等级为: S275;
2. 外形尺寸允许偏差为 $\pm 0.5$ mm, 角度的允许偏差为 $\pm 0.5^\circ$ ; 孔位的允许偏差为 $\pm 0.5$ mm, 孔距的允许偏差为 $\pm 0.5$ mm, 累计偏差为 $\pm 0.5$ mm;
3. 槽口、豁口的长宽边允许偏差为 $+0.5$ mm, 中心线允许偏差都为 $\pm 0.5$ mm;
4. " \* "为重要尺寸, 加工过程中要保证此尺寸, 加工完毕须标示代号。



美特铝质有限公司  
MIDI Aluminium Fabricator Ltd.

工程号	J853	制图	J.L.	05/6/24	物料号	J853-GB-ST-813	
地盘	香港延坪路	复核	-	-	图号	J853-GB-ST-813	
名称	铁件加工图	批准	-	-	数量	6	
材料	40x40x5mm 铁角	单件重量(kg)	0.18	长度	60	宽度	-

版本		采用	工厂		地盘	√
日期		颜色	热浸锌			

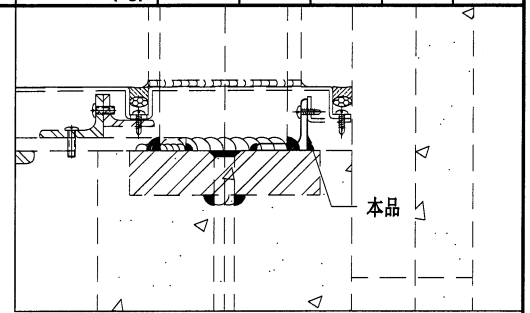

位置	数量	位置	数量	位置	数量
HB1	2	HC1		HD1	
HB2	1	HC2	1	HD2	
HB3		HC3		HD3	1
HB5		HC5		HD5	
HB6		HC6		HD6	
HB7	1	总数	1	HD7	
HB8				总数	1
总数	4				

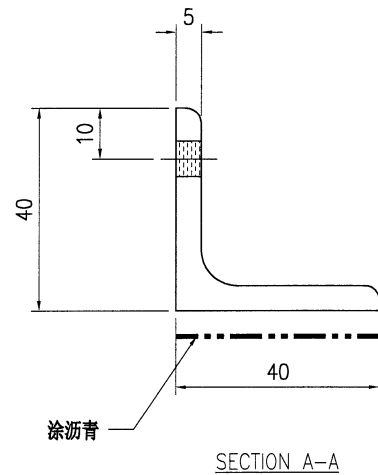
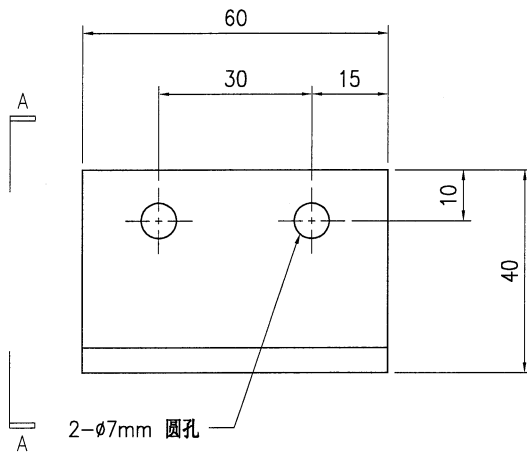

技术说明:

1. 所需材料为: 铁件 ; 等级为: S275 ;
2. 外形尺寸允许偏差为 $\pm 0.5$ mm, 角度的允许偏差为 $\pm 0.5^\circ$ ; 孔位的允许偏差为 $\pm 0.5$ mm, 孔距的允许偏差为 $\pm 0.5$ mm, 累计偏差为 $\pm 0.5$ mm;
3. 槽口、豁口的长宽边允许偏差为 $+0.5$ mm, 中心线允许偏差都为 $\pm 0.5$ mm;
4. " \* "为重要尺寸, 加工过程中要保证此尺寸, 加工完毕须标示代号。

 <b>美特铝质有限公司</b> MIDI Aluminium Fabricator Ltd.				工程号 <b>J853</b>	制图 <b>J.L.</b>	日期 <b>05/6/24</b>	物料号 <b>-</b>
地盘 <b>香港延坪路</b>				复核 <b>-</b>	图号 <b>J853-GB-ST-846</b>		数量 <b>-</b>
版本 <b>-</b>	采用 <b>工厂</b>	地盘 <b>√</b>	名称 <b>铁件加工图</b>	批准 <b>-</b>	长度 <b>-</b>		宽度 <b>-</b>
日期 <b>-</b>	颜色 <b>热浸锌</b>	材料 <b>150x75x10mm 铁角</b>		单件重量(kg) <b>-</b>	长度 <b>-</b>		宽度 <b>-</b>

物料编号	DIM.A	DIM.B	DIM.C	DIM.D	DIM.E	数量	单件重量(kg)
J853-GB-ST-846A	1441	165	57.5			1	24.58
J853-GB-ST-846B	1334	57.5	57.5			5	22.75
J853-GB-ST-846C	1354	57.5	77.5			1	23.1
J853-GB-ST-846D	1380	192.5	57.5			1	23.54
J853-GB-ST-846E	1244	57.5	57.5			4	21.22
J853-GB-ST-846F	1390	57.5	202.5			1	23.71
J853-GB-ST-846G	1296	87.5	57.5			1	22.11
J853-GB-ST-846H	1260	57.5	57.5			7	21.49
J853-GB-ST-846J	1385	57.5	177.5			1	23.62
J853-GB-ST-846K	1490	165	57.5			1	25.42
J853-GB-ST-846L	1382	57.5	57.5			2	23.57
J853-GB-ST-846M	1477	57.5	142.5			1	25.19
J853-GB-ST-846N	1277	177.5	57.5			1	21.78
J853-GB-ST-846P	1157	57.5	57.5			2	19.74
J853-GB-ST-846Q	1039	57.5	15			1	17.72
J853-GB-ST-846R	1060	57.5	57.5			1	18.08
J853-GB-ST-846S	1330	57.5	327.5			1	22.69
J853-GB-ST-846T	1546	327.5	57.5			1	26.37
J853-GB-ST-846U	1277	57.5	57.5			1	21.78
J853-GB-ST-846V	1371	57.5	142.5			1	23.39
J853-GB-ST-846W	1377	177.5	57.5			1	23.49
J853-GB-ST-846X	1297	57.5	97.5			1	22.12

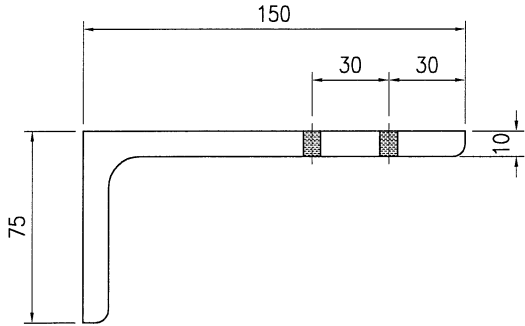
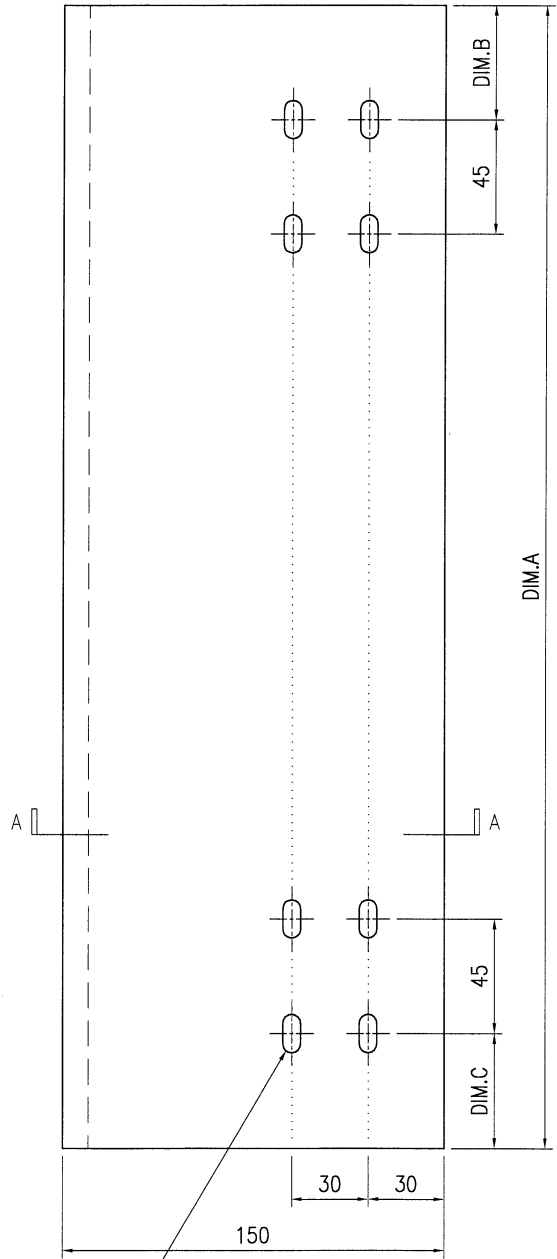
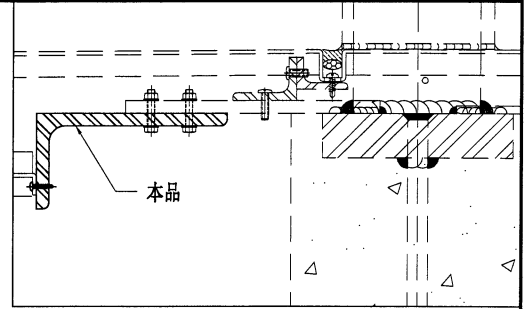

SECTION A-A

技术说明:  
 1. 所需材料为: 铁件; 等级为: S275 ;  
 2. 外形尺寸允许偏差为±0.5mm, 角度的允许偏差为±0.5°; 孔位的允许偏差为±0.5mm, 孔距的允许偏差为±0.5mm, 累计偏差为±0.5mm;  
 3. 槽口、豁口的长宽边允许偏差为+0.5mm, 中心线允许偏差都为±0.5mm;  
 4. \* "为重要尺寸, 加工过程中要保证此尺寸, 加工完毕须标示代号。



美特铝质有限公司  
MIDI Aluminium Fabricator Ltd.

工程号	J853	制图	J.L.	05/6/24	物料号	J853-GB-ST-847			
地盘	香港延坪路	复核	-	-	图号	J853-GB-ST-847			
版本		名称	铁件加工图	批准	-	数量	1		
日期		材料	150x75x10mm 铁角	单件重量(kg)	17.35	长度	1017	宽度	-

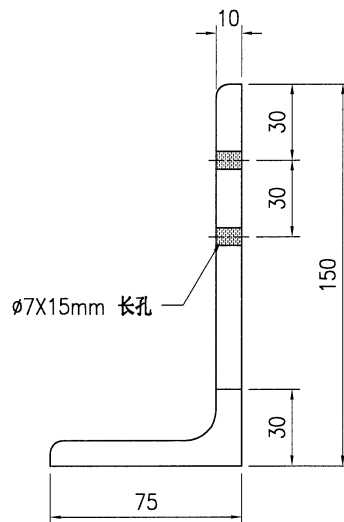
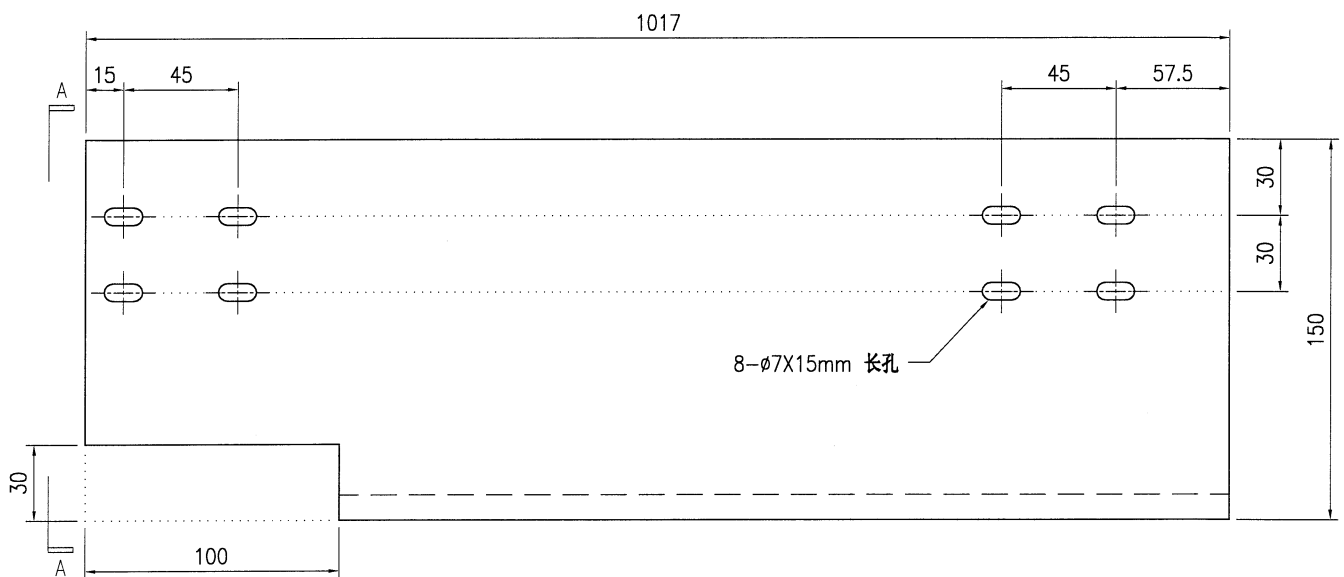
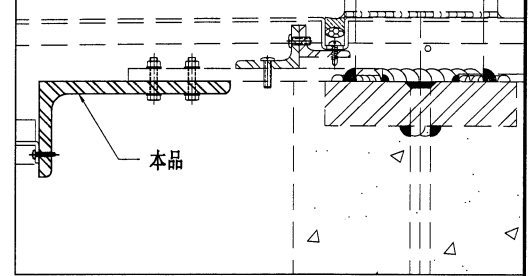

SECTION A-A

技术说明:

1. 所需材料为: 铁件; 等级为: S275;
2. 外形尺寸允许偏差为 $\pm 0.5\text{mm}$ , 角度的允许偏差为 $\pm 0.5^\circ$ ; 孔位的允许偏差为 $\pm 0.5\text{mm}$ , 孔距的允许偏差为 $\pm 0.5\text{mm}$ , 累计偏差为 $\pm 0.5\text{mm}$ ;
3. 槽口、豁口的长宽边允许偏差为 $+0.5\text{mm}$ , 中心线允许偏差都为 $\pm 0.5\text{mm}$ ;
4. " \* "为重要尺寸, 加工过程中要保证此尺寸, 加工完毕须标示代号。

 <b>美特铝质有限公司</b> MIDI Aluminium Fabricator Ltd.				工程号 J853 地盘 香港延坪路	制图 J.L. 复核 -	05/6/24 -	物料号 - 图号 J853-GB-ST-848
版本 日期	采用 颜色	工厂 热浸锌	地盘 热浸锌	名称 铁件加工图 材料 50x34x6mm 铁角	批准 单件重量(kg)	数量 长度	宽度

物料编号	DIM.A	DIM.B	DIM.C	DIM.D	DIM.E	数量	单件重量(kg)
J853-GB-ST-848A	1441	165	57.5	@450x3		1	5.43
J853-GB-ST-848B	1334	57.5	57.5	@500x2		5	5.03
J853-GB-ST-848C	1404	57.5	127.5	@450x3		1	5.29
J853-GB-ST-848D	1380	192.5	57.5	@450x3		1	5.2
J853-GB-ST-848E	1244	57.5	57.5	@500x2		4	4.69
J853-GB-ST-848F	1390	57.5	202.5	@450x3		1	5.24
J853-GB-ST-848G	1336	127.5	57.5	@500x2		1	5.04
J853-GB-ST-848H	1260	57.5	57.5	@500x2		7	4.75
J853-GB-ST-848J	1385	57.5	177.5	@450x3		1	5.22
J853-GB-ST-848K	1490	165	57.5	@450x3		1	5.62
J853-GB-ST-848L	1382	57.5	57.5	@450x3		2	5.21
J853-GB-ST-848M	1477	57.5	142.5	@450x3		1	5.57
J853-GB-ST-848N	1277	177.5	57.5	@500x2		1	4.82
J853-GB-ST-848P	1157	57.5	57.5	@500x2		2	4.36
J853-GB-ST-848Q	1139	57.5	115	@500x2		1	4.3
J853-GB-ST-848R	1060	57.5	57.5	@500x2		2	4
J853-GB-ST-848S	1267	57.5	265	@500x2		1	4.78
J853-GB-ST-848T	1484	265	57.5	@450x3		1	5.6
J853-GB-ST-848U	1277	57.5	57.5	@500x2		1	4.82
J853-GB-ST-848V	1371	57.5	142.5	@500x2		1	5.17
J853-GB-ST-848W	1377	177.5	57.5	@500x2		1	5.19
J853-GB-ST-848X	1297	57.5	97.5	@500x2		1	4.89

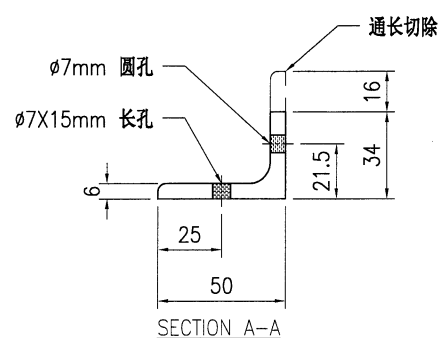
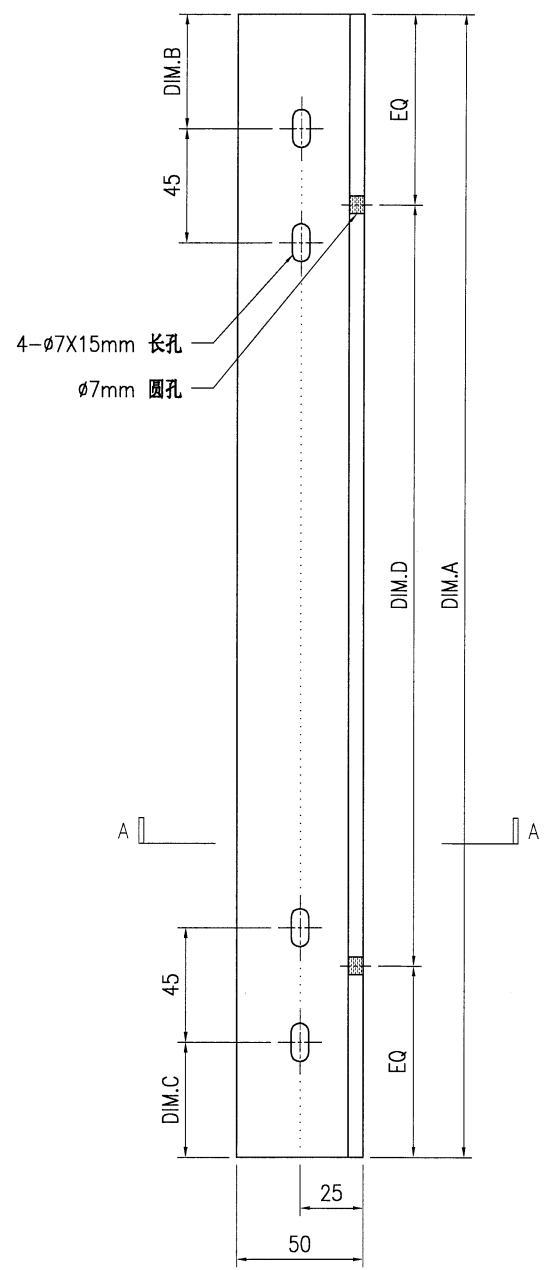
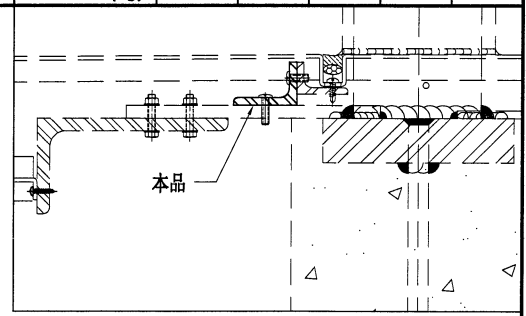

技术说明:  
 1. 所需材料为: 铁件; 等级为: S275;  
 2. 外形尺寸允许偏差为 $\pm 0.5$ mm, 角度的允许偏差为 $\pm 0.5^\circ$ ; 孔位的允许偏差为 $\pm 0.5$ mm, 孔距的允许偏差为 $\pm 0.5$ mm, 累计偏差为 $\pm 0.5$ mm;  
 3. 槽口、豁口的长宽边允许偏差为 $+0.5$ mm, 中心线允许偏差都为 $\pm 0.5$ mm;  
 4. \* "为重要尺寸, 加工过程中要保证此尺寸, 加工完毕须标示代号。



美特铝质有限公司  
MIDI Aluminium Fabricator Ltd.

工程号	J853	制图	J.L.	05/6/24	物料号	-	
地盘	香港延坪路	复核	-	-	图号	J853-GB-ST-849	
版本		名称	铁件加工图	批准	-	数量	-
日期		材料	40x25x5mm 铁角	单件重量(kg)	-	长度	-

采用	工厂	地盘	√
颜色	热浸锌		

物料编号	DIM.A	DIM.B	DIM.C	DIM.D	DIM.E	数量	单件重量(kg)
J853-GB-ST-849A	1441	@450x3				1	3.5
J853-GB-ST-849B	1335	@500x2				6	3.24
J853-GB-ST-849C	1404	@450x3				1	3.41
J853-GB-ST-849D	1380	@450x3				3	3.35
J853-GB-ST-849E	1244	@500x2				4	3.02
J853-GB-ST-849F	1387	@450x3				2	3.36
J853-GB-ST-849G	1260	@500x2				7	3.06
J853-GB-ST-849H	1490	@450x3				2	3.61
J853-GB-ST-849J	1477	@450x3				1	3.58
J853-GB-ST-849K	1277	@500x2				2	3.1
J853-GB-ST-849L	1157	@500x2				2	2.81
J853-GB-ST-849M	1139	@500x2				1	2.76
J853-GB-ST-849N	1060	@500x2				2	2.57
J853-GB-ST-849P	1267	@500x2				1	3.07
J853-GB-ST-849Q	1371	@500x2				2	3.33
J853-GB-ST-849R	1297	@500x2				1	3.15

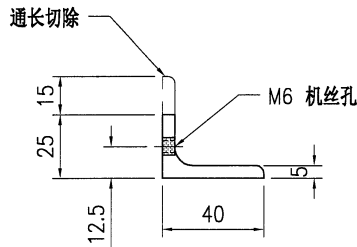
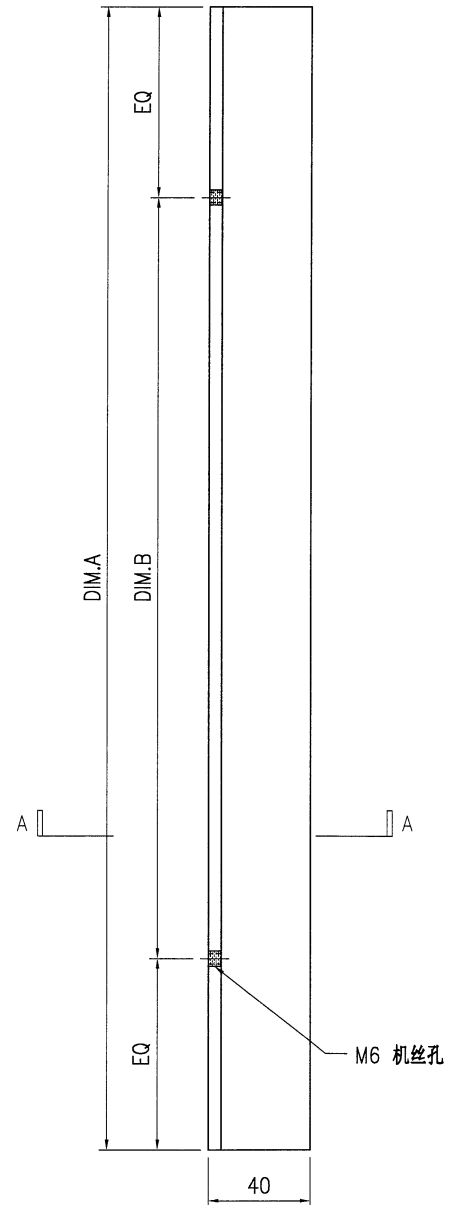
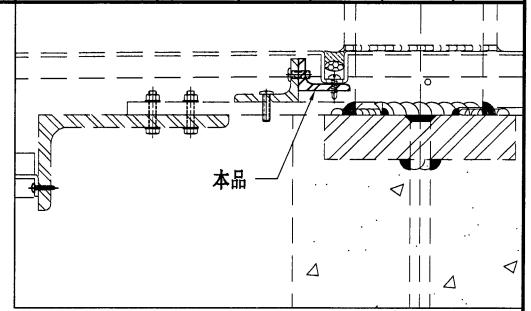

技术说明:

1. 所需材料为: 铁件; 等级为: S275;
2. 外形尺寸允许偏差为±0.5mm, 角度的允许偏差为±0.5°; 孔位的允许偏差为±0.5mm, 孔距的允许偏差为±0.5mm, 累计偏差为±0.5mm;
3. 槽口、豁口的长宽边允许偏差为+0.5mm, 中心线允许偏差都为±0.5mm;
4. " \* "为重要尺寸, 加工过程中要保证此尺寸, 加工完毕须标示代号。



美特铝质有限公司  
MIDI Aluminium Fabricator Ltd.

工程号	J853	制图	J.L.	05/6/24	物料号	-
地盘	香港延坪路	复核	-	-	图号	J853-GB-ST-850
版本		批准	-	-	数量	-
日期		材料	100x50x6mm 铁角	单件重量(kg)	-	长度 - 宽度 -

采用	工厂	地盘	√
颜色	热浸锌		

物料编号	DIM.A	DIM.B	DIM.C	DIM.D	DIM.E	数量	单件重量(kg)
J853-GB-ST-850A	1250					5	8.59
J853-GB-ST-850B	1159					4	7.96
J853-GB-ST-850C	1178					7	8.09
J853-GB-ST-850D	1297					2	8.91
J853-GB-ST-850E	950					1	6.53
J853-GB-ST-850F	1072					2	7.36
J853-GB-ST-850G	975					1	6.7
J853-GB-ST-850H	1192					1	8.19
J853-GB-ST-850J	1050					1	7.21

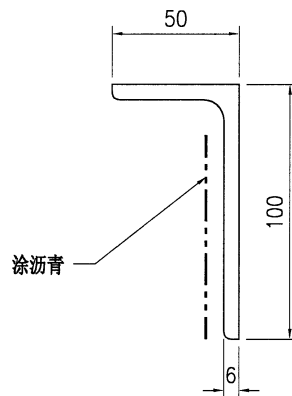
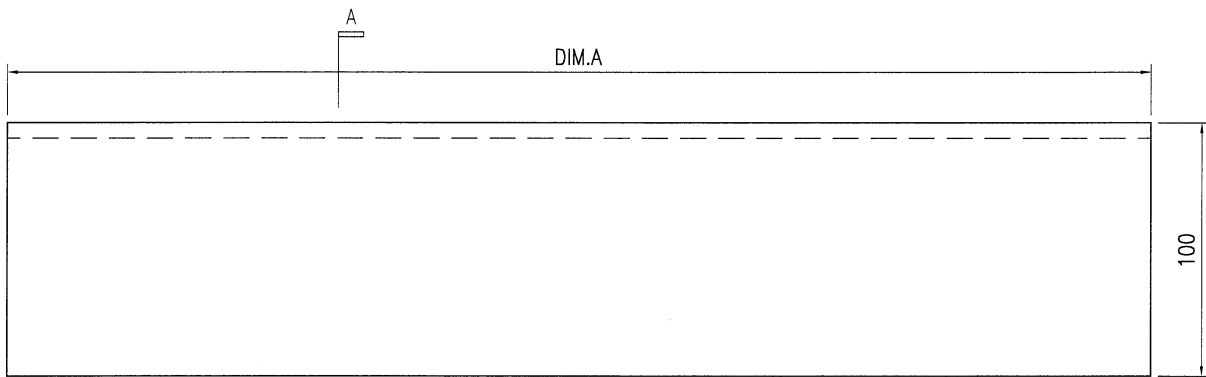
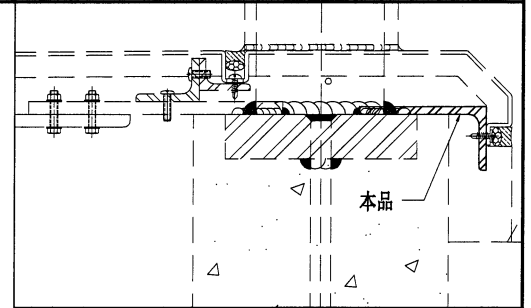

SECTION A-A

技术说明:

1. 所需材料为: 铁件; 等级为: S275;
2. 外形尺寸允许偏差为±0.5mm, 角度的允许偏差为±0.5°; 孔位的允许偏差为±0.5mm, 孔距的允许偏差为±0.5mm, 累计偏差为±0.5mm;
3. 槽口、豁口的长宽边允许偏差为+0.5mm, 中心线允许偏差都为±0.5mm;
4. " \* "为重要尺寸, 加工过程中要保证此尺寸, 加工完毕须标示代号。



美特铝质有限公司  
MIDI Aluminium Fabricator Ltd.

工程号	J853	制图	J.L.	05/6/24	物料号	-	
地盘	香港延坪路	复核	-	-	图号	J853-GB-ST-851	
名称	铁件加工图	批准	-	-	数量	-	
材料	100x50x6mm 铁角	单件重量(kg)	-	长度	-	宽度	-

版本		采用	工厂	地盘	√
日期		颜色	热浸锌		

物料编号	DIM.A	DIM.B	DIM.C	DIM.D	DIM.E	数量	单件重量(kg)
J853-GB-ST-851A	1399	150				1	9.61
J853-GB-ST-851B	1302	145				1	8.94
J853-GB-ST-851C	1318	150				1	9.05
J853-GB-ST-851D	1447	150				1	9.94
J853-GB-ST-851E	1269	78				1	8.72

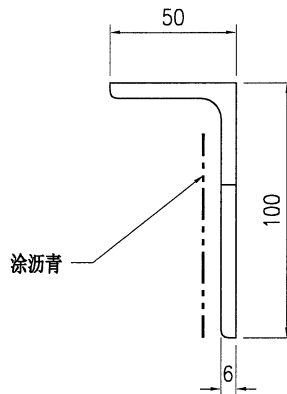
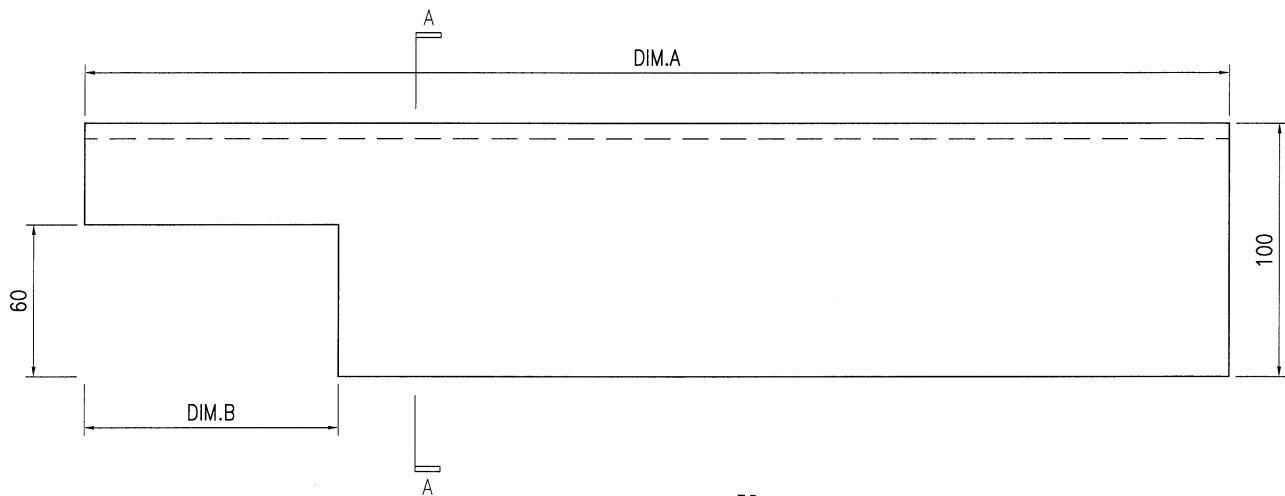
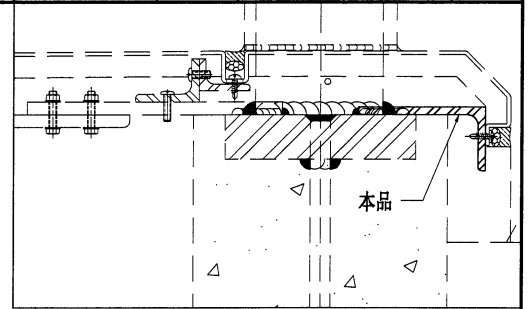

SECTION A-A

技术说明:

1. 所需材料为: 铁件; 等级为: S275;
2. 外形尺寸允许偏差为±0.5mm, 角度的允许偏差为±0.5°; 孔位的允许偏差为±0.5mm, 孔距的允许偏差为±0.5mm, 累计偏差为±0.5mm;
3. 槽口、豁口的长宽边允许偏差为+0.5mm, 中心线允许偏差都为±0.5mm;
4. " \* "为重要尺寸, 加工过程中要保证此尺寸, 加工完毕须标示代号。



美特鋁質有限公司  
MIDI Aluminium Fabricator Ltd.

工程号	J853	制图	J.L.	05/6/24	物料号	-
地盘	香港延坪路	复核	-	-	图号	J853-GB-ST-852
版本		批准	-	-	数量	-
日期		材料	100x50x6mm 铁角	单件重量(kg)	-	长度 - 宽度 -

采用	工厂	地盘	√
名称	铁件加工图		
颜色	热浸锌		

物料编号	DIM.A	DIM.B	DIM.C	DIM.D	DIM.E	数量	单件重量(kg)
J853-GB-ST-852A	1435	128				1	9.86
J853-GB-ST-852B	1052	78				1	7.23
J853-GB-ST-852C	1329	128				1	9.13
J853-GB-ST-852D	1360	175				1	9.34

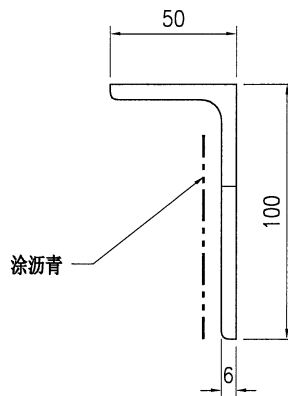
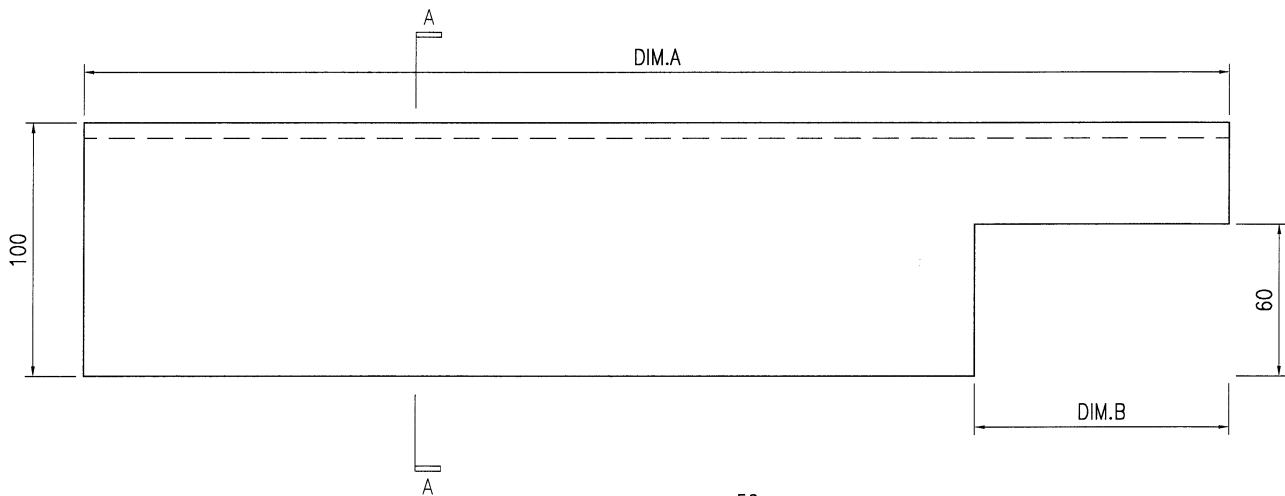
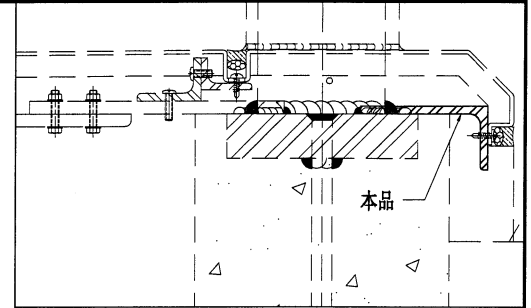

SECTION A-A

技术说明:

1. 所需材料为: 铁件; 等级为: S275;
2. 外形尺寸允许偏差为±0.5mm, 角度的允许偏差为±0.5°; 孔位的允许偏差为±0.5mm, 孔距的允许偏差为±0.5mm, 累计偏差为±0.5mm;
3. 槽口、豁口的长宽边允许偏差为+0.5mm, 中心线允许偏差都为±0.5mm;
4. \* \* 为重要尺寸, 加工过程中要保证此尺寸, 加工完毕须标示代号。



美特铝质有限公司  
MIDI Aluminium Fabricator Ltd.

工程号	J853	制图	J.L.	05/6/24	物料号	-	
地盘	香港延坪路	复核	-	-	图号	J853-GB-ST-853	
名称	铁件加工图	批准	-	-	数量	-	
材料	100x50x6mm 铁角	单件重量(kg)	-	长度	-	宽度	-

版本		采用	工厂	地盘	√
日期		颜色	热浸锌		

物料编号	DIM.A	DIM.B	DIM.C	DIM.D	DIM.E	数量	单件重量(kg)
J853-GB-ST-853A	1159	36	65			1	7.96
J853-GB-ST-853B	1073	33	60			1	7.37
J853-GB-ST-853C	1142	85	60			1	7.84

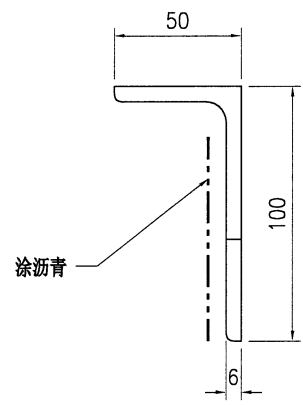
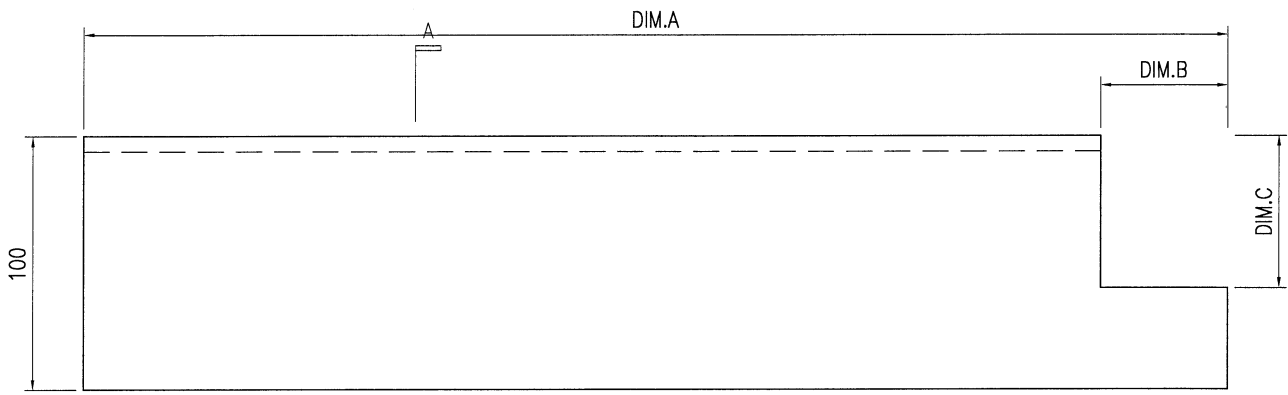
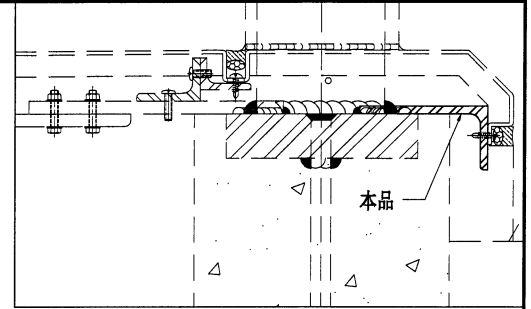

SECTION A-A

技术说明:

1. 所需材料为: 铁件; 等级为: S275;
2. 外形尺寸允许偏差为±0.5mm, 角度的允许偏差为±0.5°; 孔位的允许偏差为±0.5mm, 孔距的允许偏差为±0.5mm, 累计偏差为±0.5mm;
3. 槽口、豁口的长宽边允许偏差为+0.5mm, 中心线允许偏差都为±0.5mm;
4. " \* "为重要尺寸, 加工过程中要保证此尺寸, 加工完毕须标示代号。



美特铝质有限公司  
MIDI Aluminium Fabricator Ltd.

工程号	J853	制图	J.L.	05/6/24	物料号	J853-GB-ST-854	
地盘	香港延坪路	复核	-	-	图号	J853-GB-ST-854	
名称	铁件加工图	批准	-	-	数量	1	
材料	100x50x6mm 铁角	单件重量(kg)	9.71	长度	1414	宽度	-

版本		采用	工厂	地盘	√
日期		颜色	热浸锌		

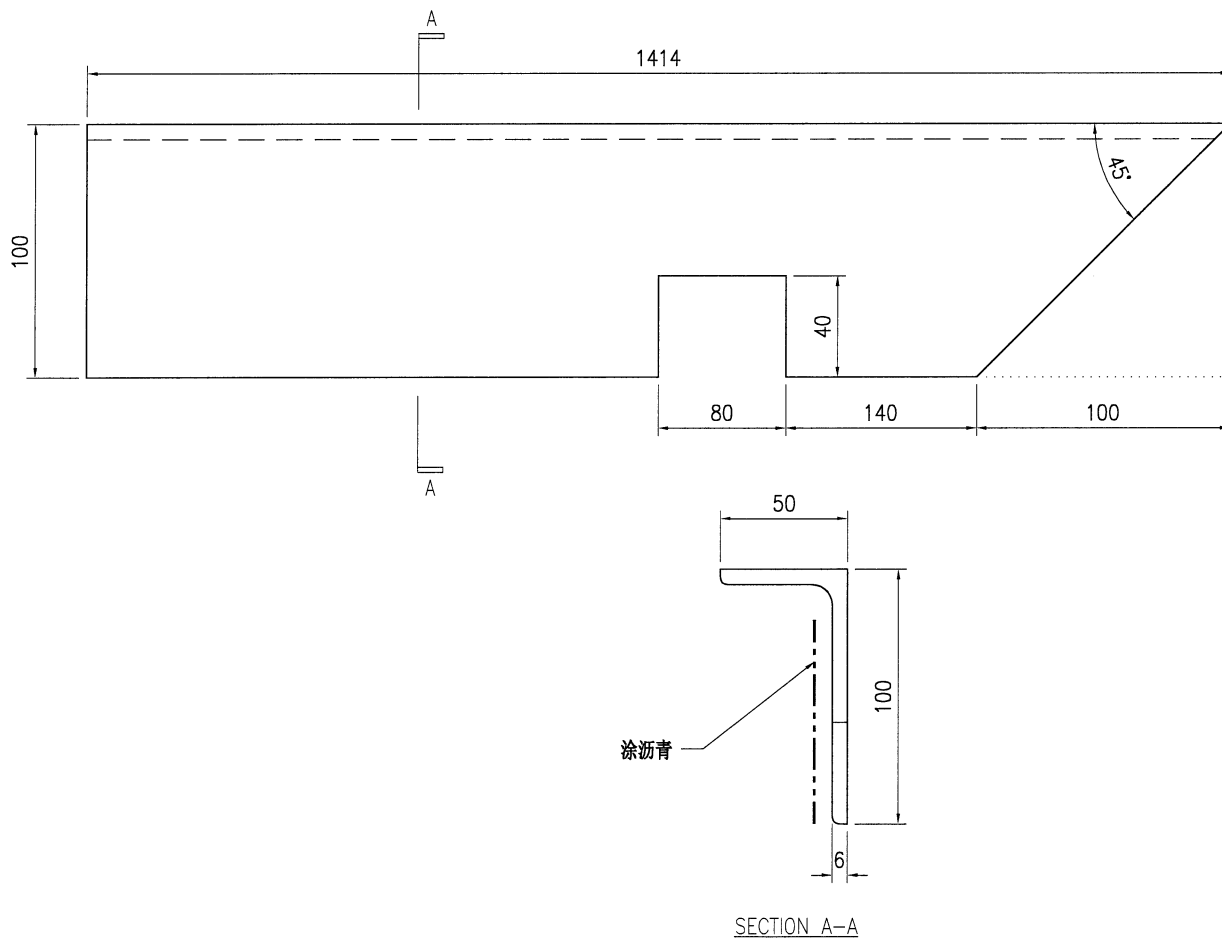
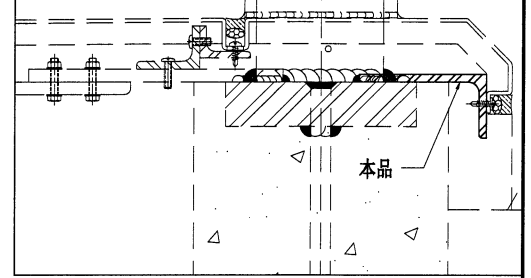

技术说明:

1. 所需材料为: 铁件; 等级为: S275;
2. 外形尺寸允许偏差为±0.5mm, 角度的允许偏差为±0.5°; 孔位的允许偏差为±0.5mm, 孔距的允许偏差为±0.5mm, 累计偏差为±0.5mm;
3. 槽口、豁口的长宽边允许偏差为+0.5mm, 中心线允许偏差都为±0.5mm;
4. " \* "为重要尺寸, 加工过程中要保证此尺寸, 加工完毕须标示代号。



美特铝质有限公司  
MIDI Aluminium Fabricator Ltd.

工程号	J853	制图	J.L.	05/6/24	物料号	J853-GB-ST-855	
地盘	香港延坪路	复核	-	-	图号	J853-GB-ST-855	
版本		名称	铁件加工图	批准	-	数量	1
日期		材料	100x50x6mm 铁角	单件重量(kg)	9.05	长度	1318
		采用	工厂			宽度	-
		颜色	热浸锌				

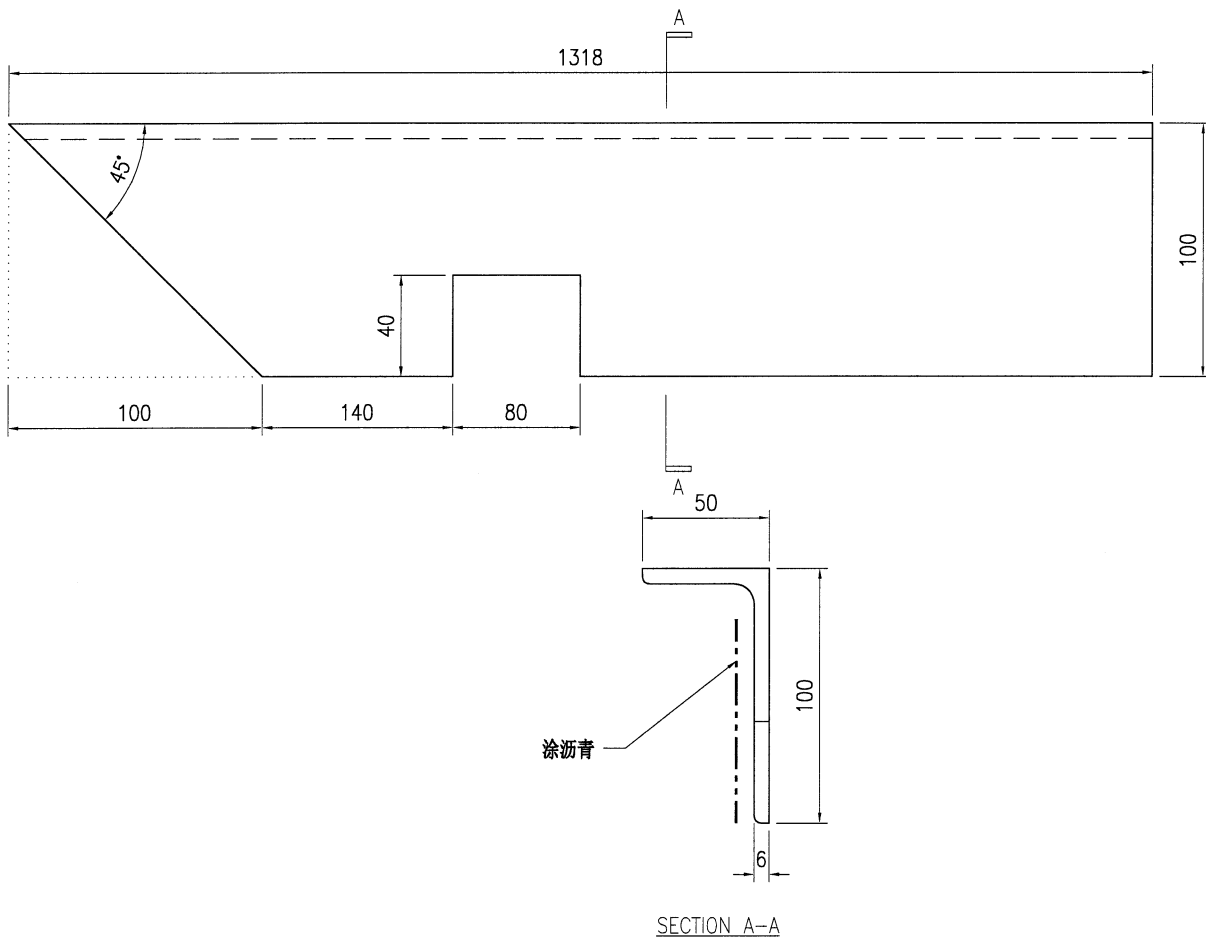
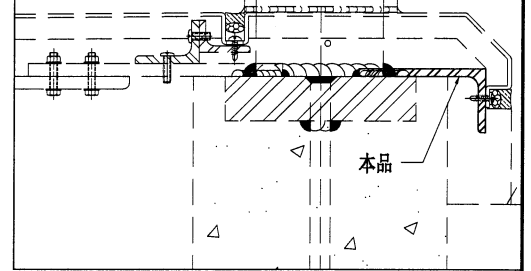

技术说明:

1. 所需材料为: 铁件; 等级为: S275;
2. 外形尺寸允许偏差为 $\pm 0.5$ mm, 角度的允许偏差为 $\pm 0.5^\circ$ ; 孔位的允许偏差为 $\pm 0.5$ mm, 孔距的允许偏差为 $\pm 0.5$ mm, 累计偏差为 $\pm 0.5$ mm;
3. 槽口、豁口的长宽边允许偏差为 $+0.5$ mm, 中心线允许偏差都为 $\pm 0.5$ mm;
4. " \* "为重要尺寸, 加工过程中要保证此尺寸, 加工完毕须标示代号。



美特铝质有限公司  
MIDI Aluminium Fabricator Ltd.

工程号	J853	制图	J.L.	29/5/24	物料号	J853-GB-ST-873	
地盘	香港延坪路	复核	-	-	图号	J853-GB-ST-873	
名称	铁件加工图	批准	-	-	数量	<del>20</del> 8	
材料	125x75x7mm 铁角	单件重量(kg)	1.61	长度	150	宽度	-

版本		采用	工厂	地盘	√
日期		颜色	热浸锌		

位置	数量
<del>HB</del>	<del>8</del>
<del>HC</del>	<del>4</del>
HD	8
总数	<del>20</del> 8

8

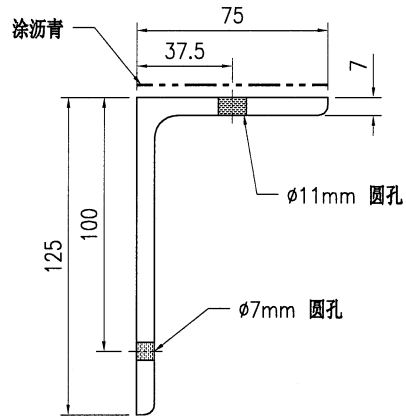
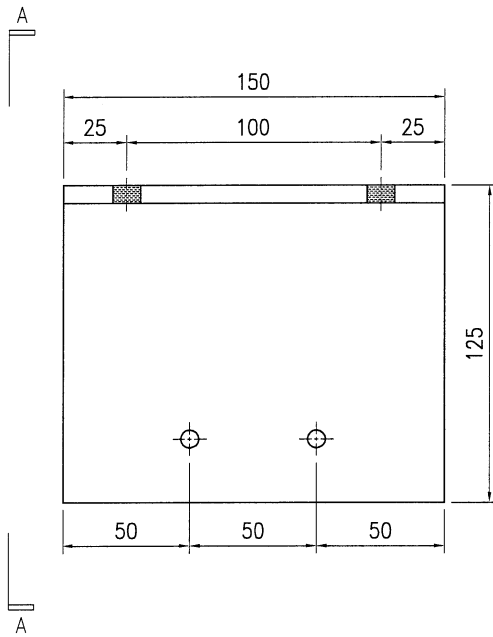
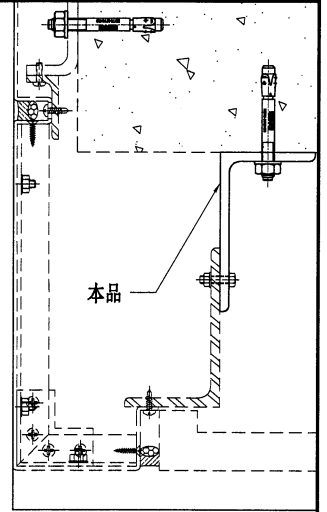

SECTION A-A

技术说明:

1. 所需材料为: 铁件; 等级为: S275;
2. 外形尺寸允许偏差为±0.5mm, 角度的允许偏差为±0.5°; 孔位的允许偏差为±0.5mm, 孔距的允许偏差为±0.5mm, 累计偏差为±0.5mm;
3. 槽口、豁口的长宽边允许偏差为+0.5mm, 中心线允许偏差都为±0.5mm;
4. " \* "为重要尺寸, 加工过程中要保证此尺寸, 加工完毕须标示代号。



美特铝质有限公司  
MIDI Aluminium Fabricator Ltd.

工程号	J853	制图	J.L.	04/7/24	物料号	-
地盘	香港延坪路	复核	-	-	图号	J853-GB-ST-875
名称	铁件加工图	批准	-	-	数量	-
材料	80x40x8mm 铁U槽	单件重量(kg)	-	-	长度	-
宽度	-					

物料编号	DIM.A	DIM.B	DIM.C	DIM.D	DIM.E	数量	单件重量(kg)	HB	HC	HD
J853-GB-ST-875A	460	300	300			2	4.04			2
J853-GB-ST-875B	760	500	@300x2			1	6.68	1		
J853-GB-ST-875C	510	350	300			1	4.48	1		
J853-GB-ST-875D	360	200	200			3	3.16	1	2	
J853-GB-ST-875E	660	500	@300x2			1	5.8			1
J853-GB-ST-875F	560	400	300			1	4.92			1

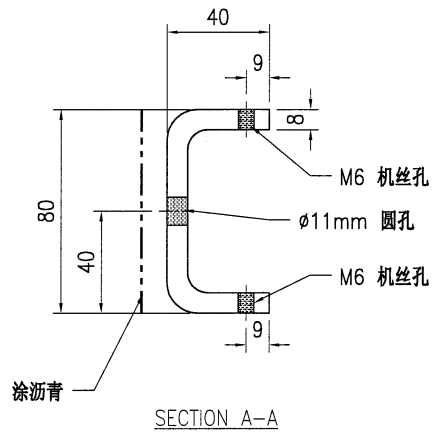
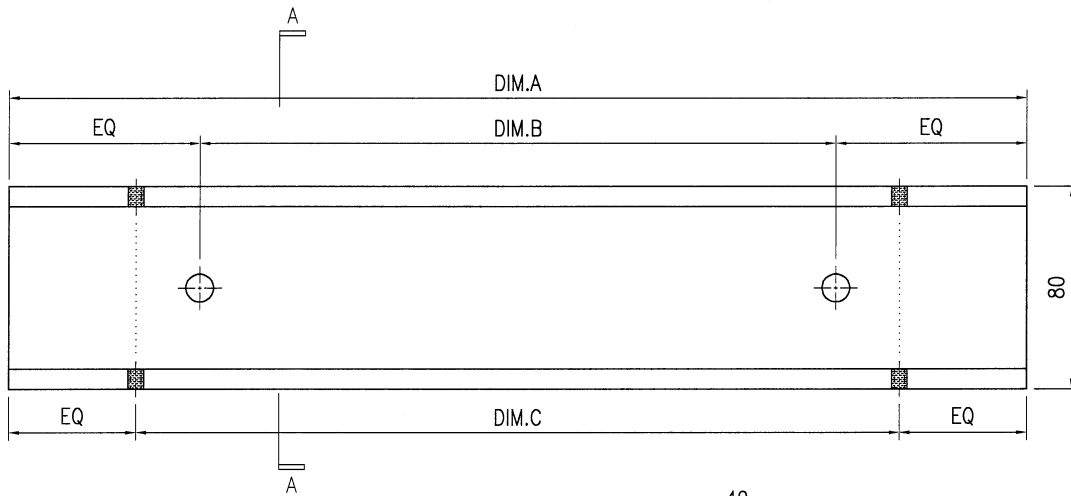
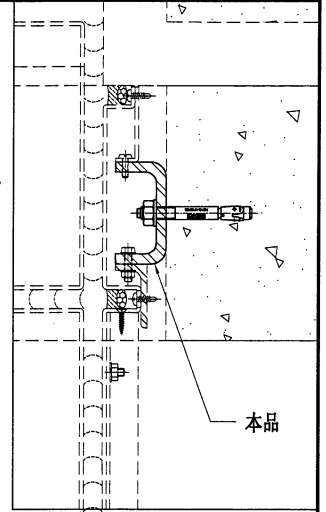

技术说明:

1. 所需材料为: 铁件; 等级为: S275;
2. 外形尺寸允许偏差为±0.5mm, 角度的允许偏差为±0.5°; 孔位的允许偏差为±0.5mm, 孔距的允许偏差为±0.5mm, 累计偏差为±0.5mm;
3. 槽口、豁口的长宽边允许偏差为+0.5mm, 中心线允许偏差都为±0.5mm;
4. " \* "为重要尺寸, 加工过程中要保证此尺寸, 加工完毕须标示代号。

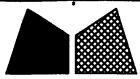

美特铝质有限公司  
MIDI Aluminium Fabricator Ltd.

工程号	J853	制图	J.L.	04/7/24	物料号	-
地盘	香港延坪路	复核	-	-	图号	J853-GB-ST-876
名称	铁件加工图	批准	-	-	数量	-
材料	50x25x5mm 铁角	单件重量(kg)	-	-	长度	-
					宽度	-

版本		采用	工厂		地盘	√
日期		颜色	热浸锌			

物料编号	DIM.A	DIM.B	DIM.C	DIM.D	DIM.E	数量	单件重量(kg)	HB	HC	HD
J853-GB-ST-876A	460	300				2	1.3			2
J853-GB-ST-876B	760	@300x2				1	2.14	1		
J853-GB-ST-876C	510	300				1	1.44	1		
J853-GB-ST-876D	360	200				3	1.01	1	2	
J853-GB-ST-876E	660	@300x2				1	1.86			1
J853-GB-ST-876F	560	300				1	1.58			1

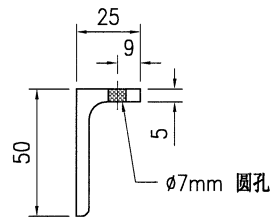
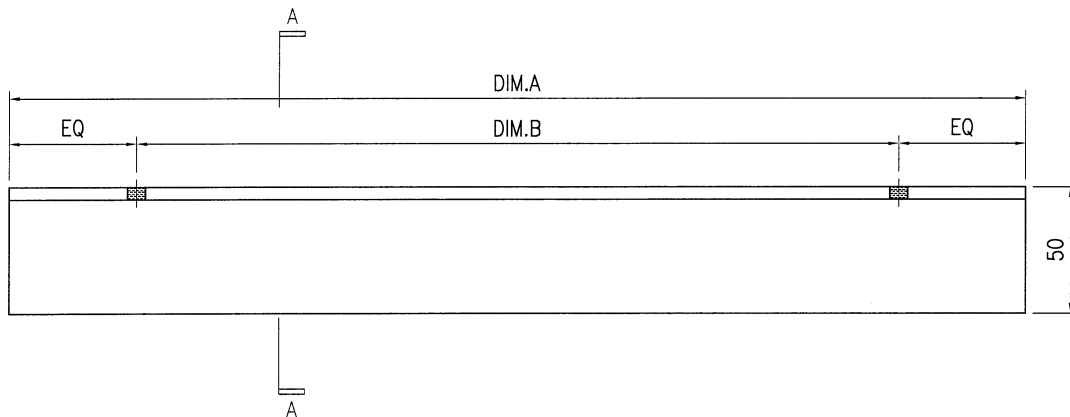
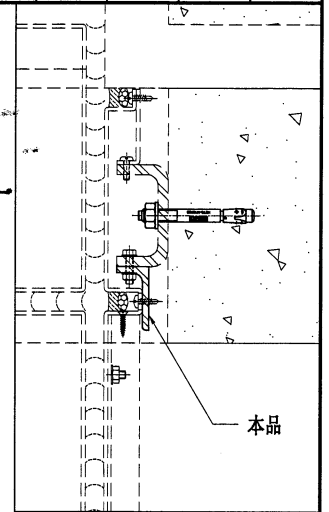

SECTION A-A

技术说明:

1. 所需材料为: 铁件; 等级为: S275;
2. 外形尺寸允许偏差为±0.5mm, 角度的允许偏差为±0.5°; 孔位的允许偏差为±0.5mm, 孔距的允许偏差为±0.5mm, 累计偏差为±0.5mm;
3. 槽口、豁口的长宽边允许偏差为+0.5mm, 中心线允许偏差都为±0.5mm;
4. " \* "为重要尺寸, 加工过程中要保证此尺寸, 加工完毕须标示代号。

 <b>美特铝质有限公司</b> MIDI Aluminium Fabricator Ltd.				工程号 J853 地盘 香港延坪路	制图 J.L. 复核 -	04/7/24 -	物料号 - 图号 J853-GB-ST-877
版本 日期	采用 颜色	工厂 热浸锌	地盘 热浸锌	名称 铁件加工图 材料 125x75x7mm 铁角	批准 单件重量(kg)	- -	数量 长度 宽度

物料编号	DIM.A	DIM.B	DIM.C	DIM.D	DIM.E	数量	单件重量(kg)	HB	HC	HD
J853-GB-ST-877A	460	300				2	4.92			2
J853-GB-ST-877B	760	500				1	8.13	1		
J853-GB-ST-877C	510	350				1	5.46	1		
J853-GB-ST-877D	360	200				3	3.85	1	2	
J853-GB-ST-877E	660	500				1	7.06			1
J853-GB-ST-877F	560	400				1	5.99			1

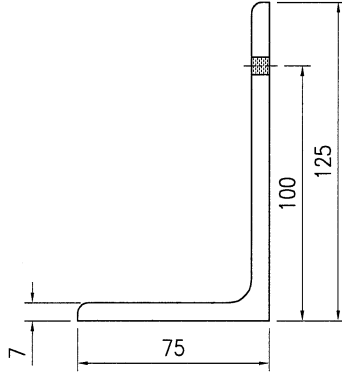
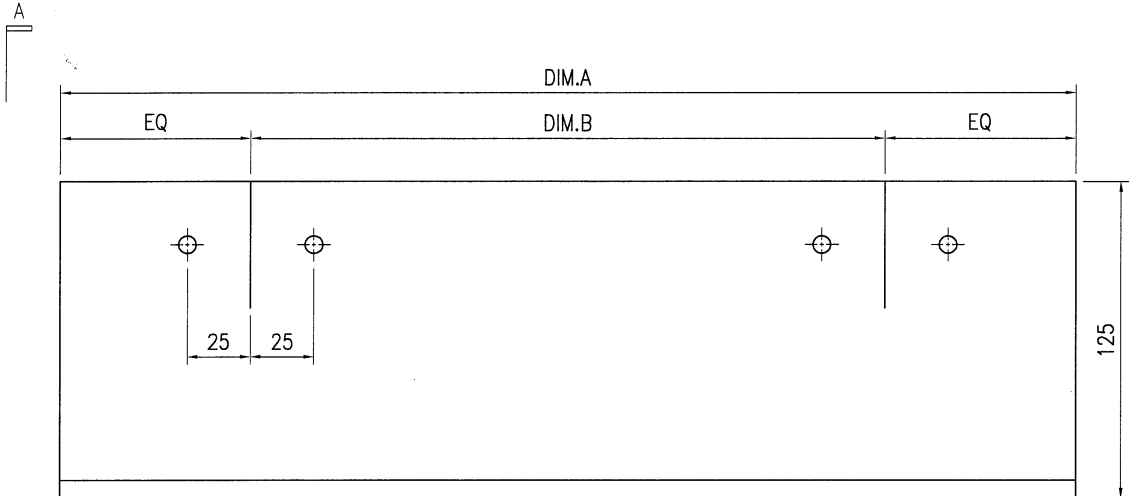
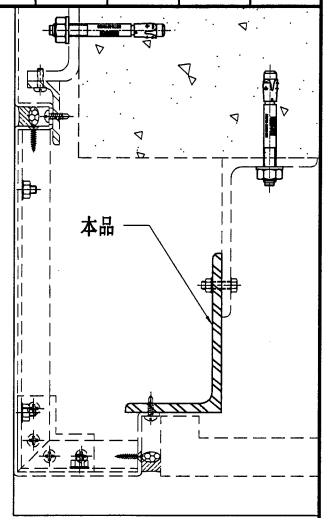

SECTION A-A

技术说明:

1. 所需材料为: 铁件; 等级为: S275;
2. 外形尺寸允许偏差为±0.5mm, 角度的允许偏差为±0.5°; 孔位的允许偏差为±0.5mm, 孔距的允许偏差为±0.5mm, 累计偏差为±0.5mm;
3. 槽口、豁口的长宽边允许偏差为+0.5mm, 中心线允许偏差都为±0.5mm;
4. " \* "为重要尺寸, 加工过程中要保证此尺寸, 加工完毕须标示代号。

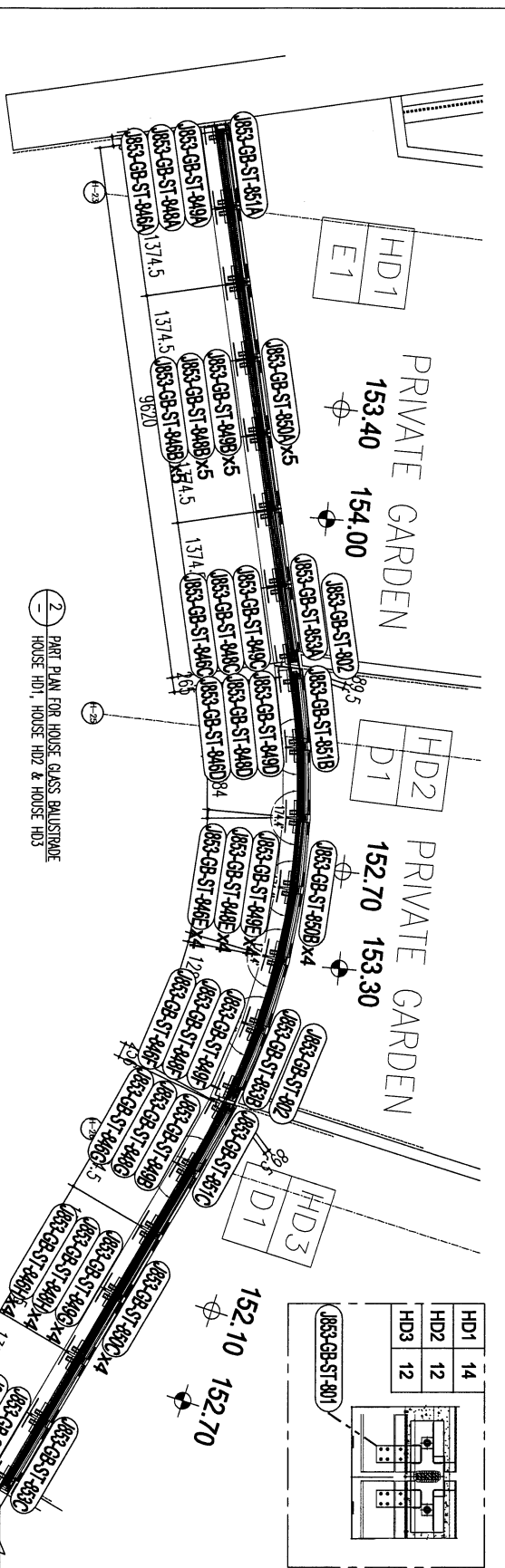
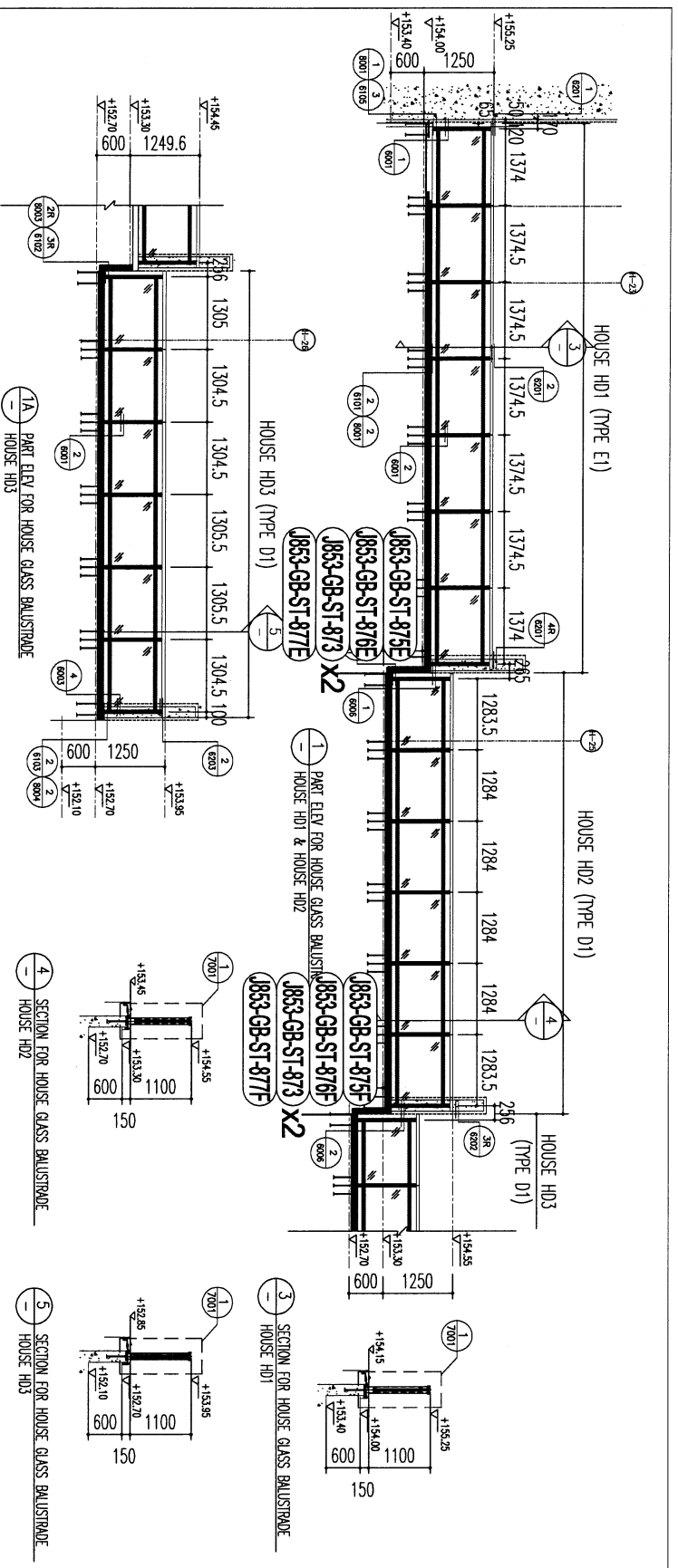

HD1	14
HD2	12
HD3	12

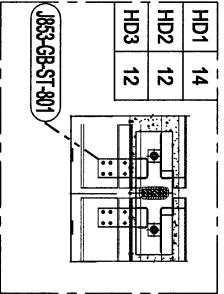

**BO. REF :**

**CLIENT :** SHIMAO GROUP HOLDINGS LIMITED

**ARCHITECT :** WPT ARCHITECTS & PLANNERS LIMITED

**MAIN CONTRACTOR :** 協興建築有限公司  
HOP HING CONSTRUCTION CO LTD

**STRUCTURAL ENGINEER :** CMA C M WONG & ASSOCIATES LTD  
黃志明建築工程師有限公司

**PROJECT :** PROPOSED RESIDENTIAL DEVELOPMENT AT N.K.L.L. 6542 YIN TRING ROAD KOWLOON

**JOB NO. :** J-653

**DATE :** 20-MAY-23

**DRAWN BY :** Y1

**CHECKED BY :**

**SCALE :** 1:80 (A3)

**DATE :** 20-MAY-23

**PROJECT :** PROPOSED RESIDENTIAL DEVELOPMENT AT N.K.L.L. 6542 YIN TRING ROAD KOWLOON

**THESE :** PART ELEV AND PART PLAN FOR HOUSE GLASS BALUSTRADE (ROW D) (1)

**COMPANY :** 美特堅有限公司  
M.T.K. ENGINEERING & ARCHITECTURE  
810 Des Voeux Road, 8/F, Hong Kong  
Tel: (852) 2777866 Fax: (852) 2777865

**REV. :**

**NOTE :**

1. ALL DIMENSIONS ARE IN MM.
2. ALL DIMENSIONS ARE VERIFIED FROM OUTSIDE.
3. ALL DIMENSIONS TO BE VERIFIED ON SITE.
4. ALL DIMENSIONS TO BE VERIFIED ON SITE.
5. ALL DIMENSIONS TO BE VERIFIED ON SITE.

**LEGEND :**

(A) DETAIL MARK NO.

(R) REFER SHEET NO.

(1) F.F.L. -- FINISHED FLOOR LEVEL

(2) S.F.L. -- STRUCTURAL FLOOR LEVEL

(3) -- REBEGED DETAIL

(4) 15MM THK. CLEAR TEMPERED GLASS

(5) 15MM THK. CLEAR TEMPERED GLASS

(6) 15MM THK. CLEAR TEMPERED GLASS

(7) 15MM THK. CLEAR TEMPERED GLASS

(8) 15MM THK. CLEAR TEMPERED GLASS

(9) 15MM THK. CLEAR TEMPERED GLASS

(10) 15MM THK. CLEAR TEMPERED GLASS

(11) 15MM THK. CLEAR TEMPERED GLASS

(12) 15MM THK. CLEAR TEMPERED GLASS

(13) 15MM THK. CLEAR TEMPERED GLASS

(14) 15MM THK. CLEAR TEMPERED GLASS

(15) 15MM THK. CLEAR TEMPERED GLASS

(16) 15MM THK. CLEAR TEMPERED GLASS

(17) 15MM THK. CLEAR TEMPERED GLASS

(18) 15MM THK. CLEAR TEMPERED GLASS

(19) 15MM THK. CLEAR TEMPERED GLASS

(20) 15MM THK. CLEAR TEMPERED GLASS

(21) 15MM THK. CLEAR TEMPERED GLASS

(22) 15MM THK. CLEAR TEMPERED GLASS

(23) 15MM THK. CLEAR TEMPERED GLASS

(24) 15MM THK. CLEAR TEMPERED GLASS

(25) 15MM THK. CLEAR TEMPERED GLASS

(26) 15MM THK. CLEAR TEMPERED GLASS

(27) 15MM THK. CLEAR TEMPERED GLASS

(28) 15MM THK. CLEAR TEMPERED GLASS

(29) 15MM THK. CLEAR TEMPERED GLASS

(30) 15MM THK. CLEAR TEMPERED GLASS

(31) 15MM THK. CLEAR TEMPERED GLASS

(32) 15MM THK. CLEAR TEMPERED GLASS

(33) 15MM THK. CLEAR TEMPERED GLASS

(34) 15MM THK. CLEAR TEMPERED GLASS

(35) 15MM THK. CLEAR TEMPERED GLASS

(36) 15MM THK. CLEAR TEMPERED GLASS

(37) 15MM THK. CLEAR TEMPERED GLASS

(38) 15MM THK. CLEAR TEMPERED GLASS

(39) 15MM THK. CLEAR TEMPERED GLASS

(40) 15MM THK. CLEAR TEMPERED GLASS

(41) 15MM THK. CLEAR TEMPERED GLASS

(42) 15MM THK. CLEAR TEMPERED GLASS

(43) 15MM THK. CLEAR TEMPERED GLASS

(44) 15MM THK. CLEAR TEMPERED GLASS

(45) 15MM THK. CLEAR TEMPERED GLASS

(46) 15MM THK. CLEAR TEMPERED GLASS

(47) 15MM THK. CLEAR TEMPERED GLASS

(48) 15MM THK. CLEAR TEMPERED GLASS

(49) 15MM THK. CLEAR TEMPERED GLASS

(50) 15MM THK. CLEAR TEMPERED GLASS

(51) 15MM THK. CLEAR TEMPERED GLASS

(52) 15MM THK. CLEAR TEMPERED GLASS

(53) 15MM THK. CLEAR TEMPERED GLASS

(54) 15MM THK. CLEAR TEMPERED GLASS

(55) 15MM THK. CLEAR TEMPERED GLASS

(56) 15MM THK. CLEAR TEMPERED GLASS

(57) 15MM THK. CLEAR TEMPERED GLASS

(58) 15MM THK. CLEAR TEMPERED GLASS

(59) 15MM THK. CLEAR TEMPERED GLASS

(60) 15MM THK. CLEAR TEMPERED GLASS

(61) 15MM THK. CLEAR TEMPERED GLASS

(62) 15MM THK. CLEAR TEMPERED GLASS

(63) 15MM THK. CLEAR TEMPERED GLASS

(64) 15MM THK. CLEAR TEMPERED GLASS

(65) 15MM THK. CLEAR TEMPERED GLASS

(66) 15MM THK. CLEAR TEMPERED GLASS

(67) 15MM THK. CLEAR TEMPERED GLASS

(68) 15MM THK. CLEAR TEMPERED GLASS

(69) 15MM THK. CLEAR TEMPERED GLASS

(70) 15MM THK. CLEAR TEMPERED GLASS

(71) 15MM THK. CLEAR TEMPERED GLASS

(72) 15MM THK. CLEAR TEMPERED GLASS

(73) 15MM THK. CLEAR TEMPERED GLASS

(74) 15MM THK. CLEAR TEMPERED GLASS

(75) 15MM THK. CLEAR TEMPERED GLASS

(76) 15MM THK. CLEAR TEMPERED GLASS

(77) 15MM THK. CLEAR TEMPERED GLASS

(78) 15MM THK. CLEAR TEMPERED GLASS

(79) 15MM THK. CLEAR TEMPERED GLASS

(80) 15MM THK. CLEAR TEMPERED GLASS

(81) 15MM THK. CLEAR TEMPERED GLASS

(82) 15MM THK. CLEAR TEMPERED GLASS

(83) 15MM THK. CLEAR TEMPERED GLASS

(84) 15MM THK. CLEAR TEMPERED GLASS

(85) 15MM THK. CLEAR TEMPERED GLASS

(86) 15MM THK. CLEAR TEMPERED GLASS

(87) 15MM THK. CLEAR TEMPERED GLASS

(88) 15MM THK. CLEAR TEMPERED GLASS

(89) 15MM THK. CLEAR TEMPERED GLASS

(90) 15MM THK. CLEAR TEMPERED GLASS

(91) 15MM THK. CLEAR TEMPERED GLASS

(92) 15MM THK. CLEAR TEMPERED GLASS

(93) 15MM THK. CLEAR TEMPERED GLASS

(94) 15MM THK. CLEAR TEMPERED GLASS

(95) 15MM THK. CLEAR TEMPERED GLASS

(96) 15MM THK. CLEAR TEMPERED GLASS

(97) 15MM THK. CLEAR TEMPERED GLASS

(98) 15MM THK. CLEAR TEMPERED GLASS

(99) 15MM THK. CLEAR TEMPERED GLASS

(100) 15MM THK. CLEAR TEMPERED GLASS

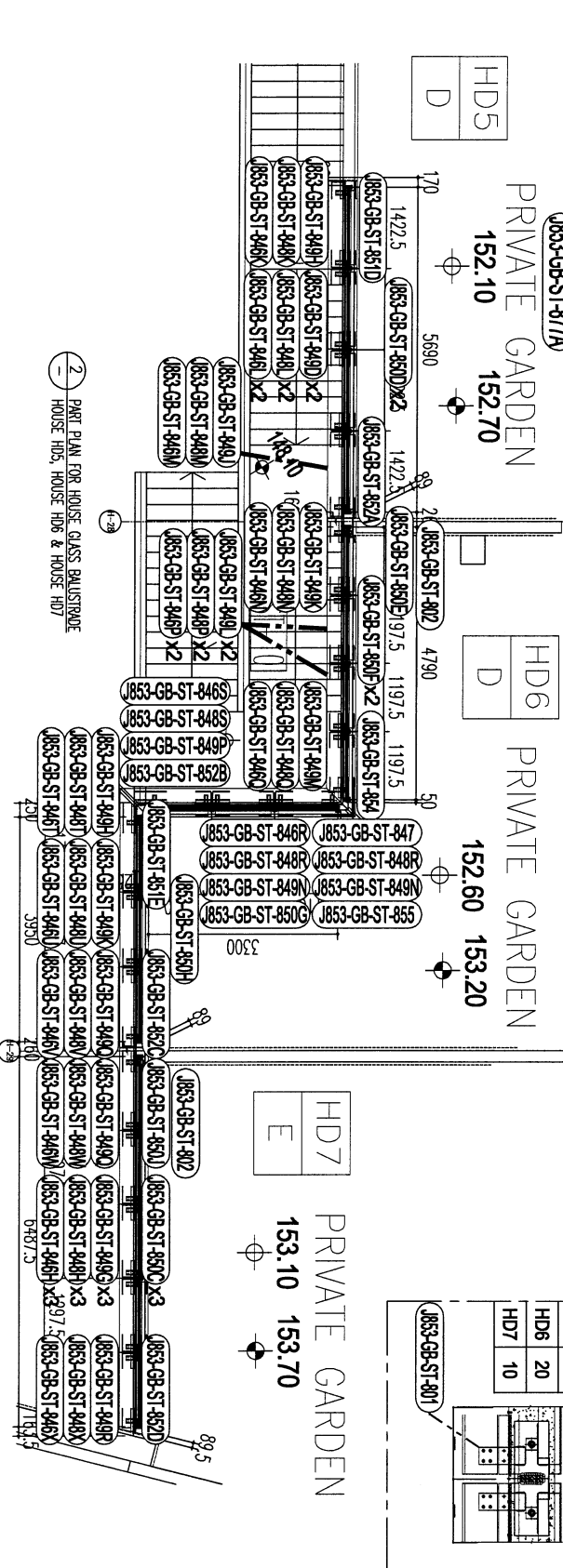
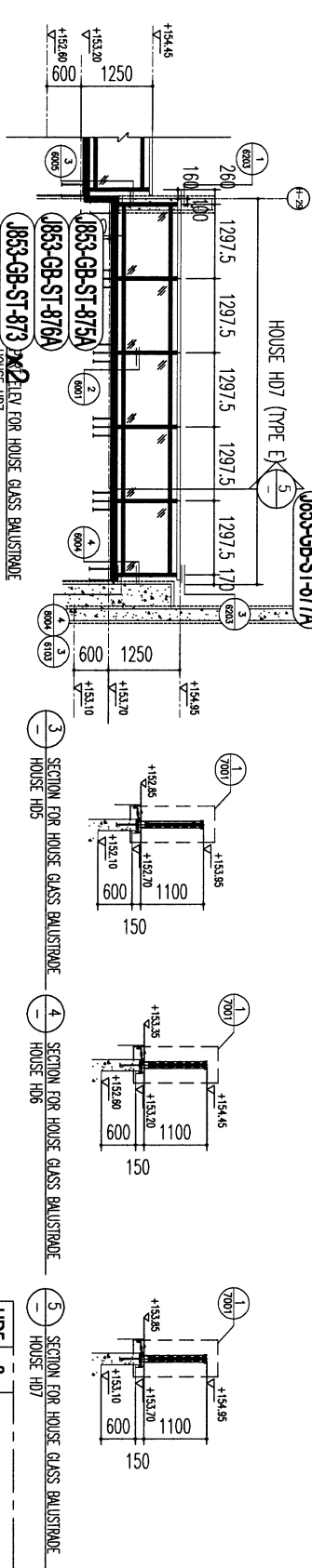
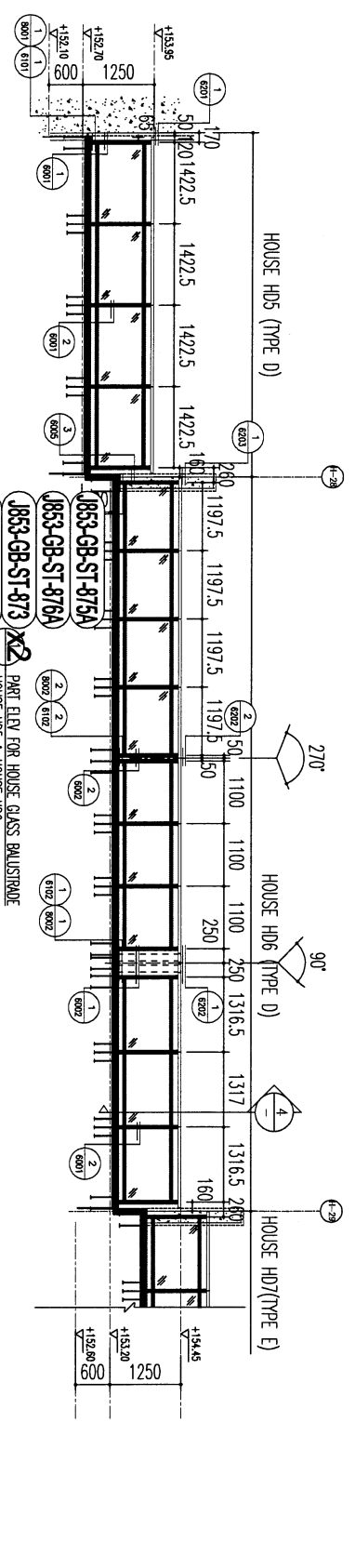

BD, REF :  
REV : -

CLIENT :  
**SHIMAO GROUP HOLDINGS LIMITED**

ARCHITECT :  
**YIP YIP YIP ARCHITECTS & PLANNERS LIMITED**

MAIN CONTRACTOR :  
**協興建築有限公司  
HIP HING CONSTRUCTION CO LTD**

STRUCTURAL ENGINEER :  
**CMA C M WONG & ASSOCIATES LTD  
黃志明建築工程師有限公司**

FRAME CONSULTANT :  
**WENHART**

NOTE :  
1. ALL DIMENSIONS ARE IN MM.  
2. ALL DIMENSIONS ARE VERNER FROM OUTSIDE.  
3. ALL DIMENSIONS TO BE VERNER ON SITE BEFORE FABRICATION.

LEGEND :  
① DETAIL MARK NO.  
② REFER SHEET NO.  
③ FINISHED FLOOR LEVEL  
④ STRUCTURAL FLOOR LEVEL  
⑤ REVERSED DETAIL

GLB : 15mm THK CLEAR TEMPERED GLASS  
1. F.E.L. -- FINISHED FLOOR LEVEL  
2. S.F.L. -- STRUCTURAL FLOOR LEVEL  
3. @ -- REVERSED DETAIL

S1 : 15mm THK CLEAR TEMPERED GLASS  
S1 : 10x10x3mm THK GLASS CHANNEL  
S2 : 20x20x3mm THK GLASS CHANNEL (GLASS ANGLE)  
S3 : 40x40x3mm THK GLASS ANGLE  
S4 : 40x40x3mm THK GLASS ANGLE  
S5 : 20x20x3mm THK GLASS ANGLE  
S6 : 20x20x3mm THK GLASS ANGLE  
S7 : 40x40x3mm THK GLASS ANGLE  
S8 : 40x40x3mm THK GLASS ANGLE  
S9 : 20x20x3mm THK GLASS ANGLE  
(CUT FROM 40x40x3mm THK GLASS ANGLE)

TABLE 1: DIMENSIONS AND LEVELS

HD5	8
HD6	20
HD7	10

TABLE 2: DIMENSIONS AND LEVELS

HD5	152.10	152.70
HD6	152.60	153.20
HD7	153.10	153.70

TABLE 3: DIMENSIONS AND LEVELS

HD5	152.10	152.70
HD6	152.60	153.20
HD7	153.10	153.70

TABLE 4: DIMENSIONS AND LEVELS

HD5	152.10	152.70
HD6	152.60	153.20
HD7	153.10	153.70

TABLE 5: DIMENSIONS AND LEVELS

HD5	152.10	152.70
HD6	152.60	153.20
HD7	153.10	153.70

TABLE 6: DIMENSIONS AND LEVELS

HD5	152.10	152.70
HD6	152.60	153.20
HD7	153.10	153.70

TABLE 7: DIMENSIONS AND LEVELS

HD5	152.10	152.70
HD6	152.60	153.20
HD7	153.10	153.70

TABLE 8: DIMENSIONS AND LEVELS

HD5	152.10	152.70
HD6	152.60	153.20
HD7	153.10	153.70

TABLE 9: DIMENSIONS AND LEVELS

HD5	152.10	152.70
HD6	152.60	153.20
HD7	153.10	153.70

TABLE 10: DIMENSIONS AND LEVELS

HD5	152.10	152.70
HD6	152.60	153.20
HD7	153.10	153.70

TABLE 11: DIMENSIONS AND LEVELS

HD5	152.10	152.70
HD6	152.60	153.20
HD7	153.10	153.70

TABLE 12: DIMENSIONS AND LEVELS

HD5	152.10	152.70
HD6	152.60	153.20
HD7	153.10	153.70

TABLE 13: DIMENSIONS AND LEVELS

HD5	152.10	152.70
HD6	152.60	153.20
HD7	153.10	153.70

TABLE 14: DIMENSIONS AND LEVELS

HD5	152.10	152.70
HD6	152.60	153.20
HD7	153.10	153.70

TABLE 15: DIMENSIONS AND LEVELS

HD5	152.10	152.70
HD6	152.60	153.20
HD7	153.10	153.70

TABLE 16: DIMENSIONS AND LEVELS

HD5	152.10	152.70
HD6	152.60	153.20
HD7	153.10	153.70

TABLE 17: DIMENSIONS AND LEVELS

HD5	152.10	152.70
HD6	152.60	153.20
HD7	153.10	153.70

TABLE 18: DIMENSIONS AND LEVELS

HD5	152.10	152.70
HD6	152.60	153.20
HD7	153.10	153.70

TABLE 19: DIMENSIONS AND LEVELS

HD5	152.10	152.70
HD6	152.60	153.20
HD7	153.10	153.70

TABLE 20: DIMENSIONS AND LEVELS

HD5	152.10	152.70
HD6	152.60	153.20
HD7	153.10	153.70

TABLE 21: DIMENSIONS AND LEVELS

HD5	152.10	152.70
HD6	152.60	153.20
HD7	153.10	153.70

TABLE 22: DIMENSIONS AND LEVELS

HD5	152.10	152.70
HD6	152.60	153.20
HD7	153.10	153.70

TABLE 23: DIMENSIONS AND LEVELS

HD5	152.10	152.70
HD6	152.60	153.20
HD7	153.10	153.70

TABLE 24: DIMENSIONS AND LEVELS

HD5	152.10	152.70
HD6	152.60	153.20
HD7	153.10	153.70

TABLE 25: DIMENSIONS AND LEVELS

HD5	152.10	152.70
HD6	152.60	153.20
HD7	153.10	153.70

TABLE 26: DIMENSIONS AND LEVELS

HD5	152.10	152.70
HD6	152.60	153.20
HD7	153.10	153.70

TABLE 27: DIMENSIONS AND LEVELS

HD5	152.10	152.70
HD6	152.60	153.20
HD7	153.10	153.70

TABLE 28: DIMENSIONS AND LEVELS

HD5	152.10	152.70
HD6	152.60	153.20
HD7	153.10	153.70

TABLE 29: DIMENSIONS AND LEVELS

HD5	152.10	152.70
HD6	152.60	153.20
HD7	153.10	153.70

TABLE 30: DIMENSIONS AND LEVELS

HD5	152.10	152.70
HD6	152.60	153.20
HD7	153.10	153.70

TABLE 31: DIMENSIONS AND LEVELS

HD5	152.10	152.70
HD6	152.60	153.20
HD7	153.10	153.70

TABLE 32: DIMENSIONS AND LEVELS

HD5	152.10	152.70
HD6	152.60	153.20
HD7	153.10	153.70

TABLE 33: DIMENSIONS AND LEVELS

HD5	152.10	152.70
HD6	152.60	153.20
HD7	153.10	153.70

TABLE 34: DIMENSIONS AND LEVELS

HD5	152.10	152.70
HD6	152.60	153.20
HD7	153.10	153.70

TABLE 35: DIMENSIONS AND LEVELS

HD5	152.10	152.70
HD6	152.60	153.20
HD7	153.10	153.70

TABLE 36: DIMENSIONS AND LEVELS

HD5	152.10	152.70
HD6	152.60	153.20
HD7	153.10	153.70

TABLE 37: DIMENSIONS AND LEVELS

HD5	152.10	152.70
HD6	152.60	153.20
HD7	153.10	153.70

TABLE 38: DIMENSIONS AND LEVELS

HD5	152.10	152.70
HD6	152.60	153.20
HD7	153.10	153.70

TABLE 39: DIMENSIONS AND LEVELS

HD5	152.10	152.70
HD6	152.60	153.20
HD7	153.10	153.70

TABLE 40: DIMENSIONS AND LEVELS

HD5	152.10	152.70
HD6	152.60	153.20
HD7	153.10	153.70

TABLE 41: DIMENSIONS AND LEVELS

HD5	152.10	152.70
HD6	152.60	153.20
HD7	153.10	153.70

TABLE 42: DIMENSIONS AND LEVELS

HD5	152.10	152.70
HD6	152.60	153.20
HD7	153.10	153.70

TABLE 43: DIMENSIONS AND LEVELS

HD5	152.10	152.70
HD6	152.60	153.20
HD7	153.10	153.70

TABLE 44: DIMENSIONS AND LEVELS

HD5	152.10	152.70
HD6	152.60	153.20
HD7	153.10	153.70

TABLE 45: DIMENSIONS AND LEVELS

HD5	152.10	152.70
HD6	152.60	153.20
HD7	153.10	153.70

TABLE 46: DIMENSIONS AND LEVELS

HD5	152.10	152.70
HD6	152.60	153.20
HD7	153.10	153.70

TABLE 47: DIMENSIONS AND LEVELS

HD5	152.10	152.70
HD6	152.60	153.20
HD7	153.10	153.70

TABLE 48: DIMENSIONS AND LEVELS

HD5	152.10	152.70
HD6	152.60	153.20
HD7	153.10	153.70

TABLE 49: DIMENSIONS AND LEVELS

HD5	152.10	152.70
HD6	152.60	153.20
HD7	153.10	153.70

TABLE 50: DIMENSIONS AND LEVELS

HD5	152.10	152.70
HD6	152.60	153.20
HD7	153.10	153.70

TABLE 51: DIMENSIONS AND LEVELS

HD5	152.10	152.70
HD6	152.60	153.20
HD7	153.10	153.70

TABLE 52: DIMENSIONS AND LEVELS

HD5	152.10	152.70
HD6	152.60	153.20
HD7	153.10	153.70

TABLE 53: DIMENSIONS AND LEVELS

HD5	152.10	152.70
HD6	152.60	153.20
HD7	153.10	153.70

TABLE 54: DIMENSIONS AND LEVELS

HD5	152.10	152.70
HD6	152.60	153.20
HD7	153.10	153.70

TABLE 55: DIMENSIONS AND LEVELS

HD5	152.10	152.70
HD6	152.60	153.20
HD7	153.10	153.70

TABLE 56: DIMENSIONS AND LEVELS

HD5	152.10	152.70
HD6	152.60	153.20
HD7	153.10	153.70

TABLE 57: DIMENSIONS AND LEVELS

HD5	152.10	152.70
HD6	152.60	153.20
HD7	153.10	153.70

TABLE 58: DIMENSIONS AND LEVELS

HD5	152.10	152.70
HD6	152.60	153.20
HD7	153.10	153.70

TABLE 59: DIMENSIONS AND LEVELS

HD5	152.10	152.70
HD6	152.60	153.20
HD7	153.10	153.70

TABLE 60: DIMENSIONS AND LEVELS

HD5	152.10	152.70
HD6	152.60	153.20
HD7	153.10	153.70

TABLE 61: DIMENSIONS AND LEVELS

HD5	152.10	152.70
HD6	152.60	153.20
HD7	153.10	153.70

TABLE 62: DIMENSIONS AND LEVELS

HD5	152.10	152.70
HD6	152.60	153.20
HD7	153.10	153.70

TABLE 63: DIMENSIONS AND LEVELS

HD5	152.10	152.70
HD6	152.60	153.20
HD7	153.10	153.70

TABLE 64: DIMENSIONS AND LEVELS

HD5	152.10	152.70
HD6	152.60	153.20
HD7	153.10	153.70

TABLE 65: DIMENSIONS AND LEVELS

HD5	152.10	152.70
HD6	152.60	153.20
HD7	153.10	153.70

TABLE 66: DIMENSIONS AND LEVELS

HD5	152.10
-----	--------