

工程指示 / 要求簡箋 ENGINEER INSTRUCTIONS(E.I.)

| | | | |
|---------|-----------------------------|-------|------------|
| 工程指示編號: | EI- 6772 | 修改版本: | - |
| | HK-2209 | | |
| 工程編號: | J 853 | 工程名稱: | 延坪道 (第2期) |
| 收件人: | Maggie Lor | 發件人: | Joe Chan |
| 工程項目: | House 通道門 及 大樓 欄河拍印 繪製模圖 | 日期: | 22/09/2023 |

| | | |
|---------------------------------|--|------------------------------------|
| <input type="checkbox"/> 原合約工程包 | <input type="checkbox"/> 原合約工程加 / 減賬 QT- | <input type="checkbox"/> 新工程報價 QT- |
|---------------------------------|--|------------------------------------|

| | |
|----------------|-----------|
| 信件批核號碼/圖紙參考編號: | 批核模具圖紙編號: |
| 客戶指示附件: | 管理內部批簽署: |

| | | |
|---|-------------------------------------|-------------------------------|
| <input type="checkbox"/> 初步鋁料 B.M. | <input type="checkbox"/> 加工拆圖, 然後生產 | <input type="checkbox"/> 尺寸表 |
| <input type="checkbox"/> 正式鋁料 B.M. | <input type="checkbox"/> 技術上資料/指示 | <input type="checkbox"/> 報價 |
| <input type="checkbox"/> 配件 B.M. | <input type="checkbox"/> 樣辦或貨品說明書 | <input type="checkbox"/> 分判合約 |
| <input checked="" type="checkbox"/> 其他: | | |

內容: 請依附件資料繪製模圖, X86468 ~ X86476 共9張.
(附CAD檔)

完成上列要求日期: 10/10/2023

國內

| | | | | | |
|---------------------------------|------------------------------|--------------------------------|------------------------------|--------------------------------|------------------------------|
| <input type="checkbox"/> 生產技術總監 | <input type="checkbox"/> 連附件 | <input type="checkbox"/> 技術部 | <input type="checkbox"/> 連附件 | <input type="checkbox"/> 生產部 | <input type="checkbox"/> 連附件 |
| <input type="checkbox"/> 採購部 | <input type="checkbox"/> 連附件 | <input type="checkbox"/> 生產統籌部 | <input type="checkbox"/> 連附件 | <input type="checkbox"/> 報關組 | <input type="checkbox"/> 連附件 |
| <input type="checkbox"/> 質檢部 | <input type="checkbox"/> 連附件 | <input type="checkbox"/> 會計部 | <input type="checkbox"/> 連附件 | <input type="checkbox"/> 機械設計部 | <input type="checkbox"/> 連附件 |
| <input type="checkbox"/> 香港辦 | <input type="checkbox"/> 連附件 | <input type="checkbox"/> 其他: | | | |

香港

| | | | | | | | |
|------------------------------|------------------------------|------------------------------|------------------------------|-------------------------------|------------------------------|------------------------------|------------------------------|
| <input type="checkbox"/> 行政部 | <input type="checkbox"/> 連附件 | <input type="checkbox"/> 會計部 | <input type="checkbox"/> 連附件 | <input type="checkbox"/> 統籌部 | <input type="checkbox"/> 連附件 | <input type="checkbox"/> 工程部 | <input type="checkbox"/> 連附件 |
| <input type="checkbox"/> 採購部 | <input type="checkbox"/> 連附件 | <input type="checkbox"/> QS部 | <input type="checkbox"/> 連附件 | <input type="checkbox"/> 地盤管理 | <input type="checkbox"/> 連附件 | <input type="checkbox"/> 維修部 | <input type="checkbox"/> 連附件 |

| | | | |
|---------|--------------|------------|--|
| *發件人簽署: | | *組別成員批核簽署: | |
| 傳遞編號: | HK 2209 / 23 | 項目經理簽署: | |

| | | | |
|----------|-------------------|---------------|--------|
| CUSTOMER | CUSTOMER APPROVAL | CUST PART NO. | SD01 |
| | | SECTION NO. | X86468 |

企框

- a=0.1r
- b=0.2r
- c=0.3r
- d=0.4r
- e=0.5r
- f=0.8r
- g=1.0r
- h=1.5r

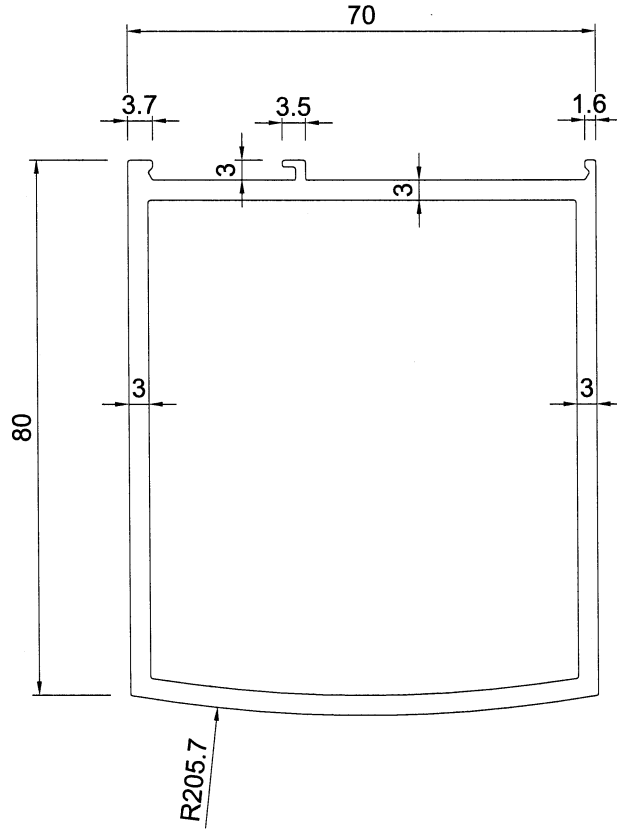

| | |
|----------|------------|
| 美特鋁質有限公司 | |
| 承認圖面 | |
| 日期 | 20/09/2023 |

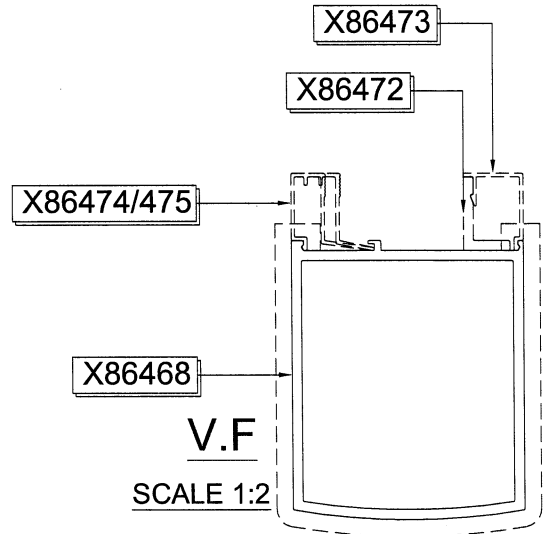

| | | | | | | | | | |
|--------------------|-------------------------|-----------------------|------------------|----------------|--------|------------|------------|---------|-----|
| SIGNATURE GRADEING | HIGH SIGNATURE GRADEING | C.C.DIA(MM) | 108.6 | | | | | | |
| AREA (SQ MM) | 870.9 | UNSPECIFIED THICKNESS | - | PERIMETER (MM) | 315.61 | STANDARD | | SCALE | 1:1 |
| MASS (KG/M) | 2.360 | UNSPECIFIED CORNERS | - | SURFACE AREA | 242.05 | ALLOY | 6063-T6 | VERSION | |
| COMPANY ISSUE | | | DRAWA | DZL | DATE | 2021-09-09 | APELLATION | PAGE OF | |
| | | | STANDA-RDIZATION | | DATE | | | | |
| | | | TO SIGN | | DATE | | | | |
| | | | AUDITING | | DATE | | | | |
| MARKER | MODIFY | FILE NO | SIGNATURE | DATE | APPROV | DATE | | | |

| | | | |
|----------|-------------------|---------------|--------|
| CUSTOMER | CUSTOMER APPROVAL | CUST PART NO. | SD02 |
| | | SECTION NO. | X86469 |

企框

a=0.1r
b=0.2r
c=0.3r
d=0.4r
e=0.5r
f=0.8r
g=1.0r
h=1.5r

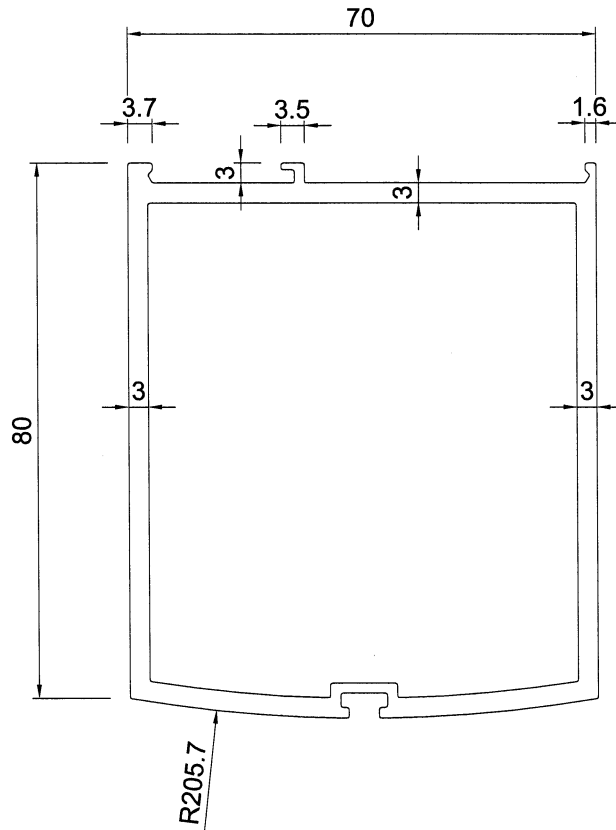

| | |
|----------|------------|
| 美特鋁質有限公司 | |
| 承認圖面 | |
| 日期 | 22/09/2023 |

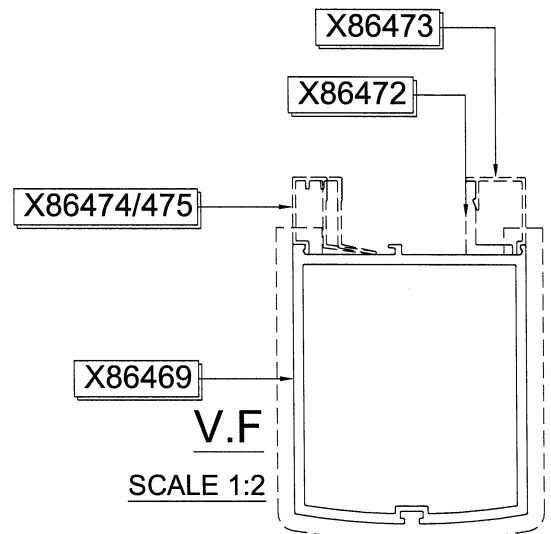

| | | | | | | | | | |
|--------------------|-------------------------|-----------------------|------------------|----------------|--------|------------|------------|---------|-----|
| SIGNATURE GRADEING | HIGH SIGNATURE GRADEING | C.C.DIA(MM) | 108.6 | | | | | | |
| AREA (SQ MM) | 871.0 | UNSPECIFIED THICKNESS | - | PERIMETER (MM) | 327.04 | STANDARD | | SCALE | 1:1 |
| MASS (KG/M) | 2.36 | UNSPECIFIED CORNERS | - | SURFACE AREA | 253.48 | ALLOY | 6063-T6 | VERSION | |
| COMPANY ISSUE | | | DRAWA | DZL | DATE | 2021-09-09 | APELLATION | PAGE OF | |
| | | | STANDA-RDIZATION | | DATE | | | | |
| | | | TO SIGN | | DATE | | | | |
| | | | AUDITING | | DATE | | | | |
| MARKER | MODIFY | FILE NO | SIGNATURE | DATE | APPROV | | | | |

| | | | |
|----------|-------------------|---------------|--------|
| CUSTOMER | CUSTOMER APPROVAL | CUST PART NO. | SD03 |
| | | SECTION NO. | X86470 |

底框

a=0.1r
b=0.2r
c=0.3r
d=0.4r
e=0.5r
f=0.8r
g=1.0r
h=1.5r

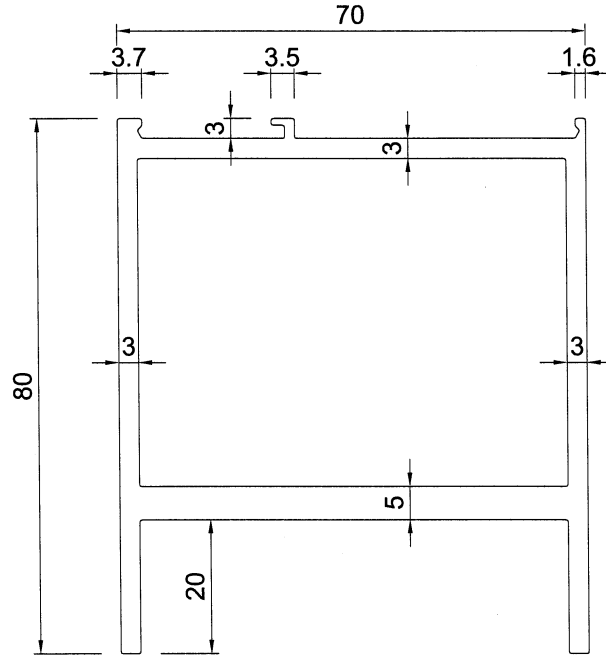

| | |
|----------|------------|
| 美特鋁質有限公司 | |
| 承認圖面 | |
| 日期 | 20/09/2023 |

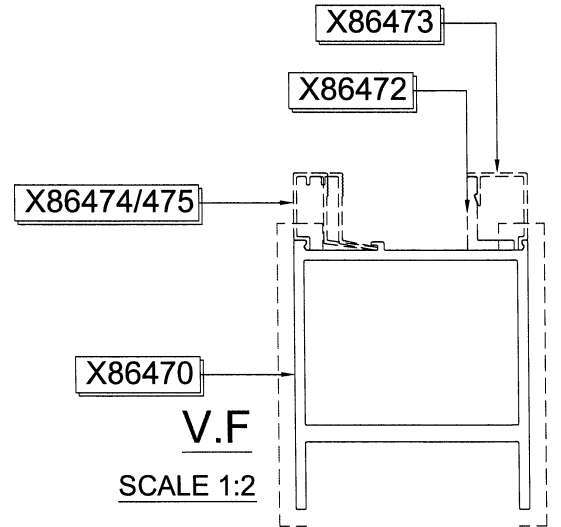

| | | | | | | | | | |
|--------------------|-------------------------|-----------------------|------------------|----------------|--------|------------|------------|---------|-----|
| SIGNATURE GRADEING | HIGH SIGNATURE GRADEING | C.C.DIA(MM) | 106.3 | | | | | | |
| AREA (SQ MM) | 996.5 | UNSPECIFIED THICKNESS | - | PERIMETER (MM) | 354.66 | STANDARD | | SCALE | 1:1 |
| MASS (KG/M) | 2.701 | UNSPECIFIED CORNERS | - | SURFACE AREA | 89.7 | ALLOY | 6063-T6 | VERSION | |
| COMPANY ISSUE | | | DRAWA | DZL | DATE | 2021-09-09 | APELLATION | PAGE OF | |
| | | | STANDA-RDIZATION | | DATE | | | | |
| | | | TO SIGN | | DATE | | | | |
| | | | AUDITING | | DATE | | | | |
| MARKER | MODIFY | FILE NO | SIGNATURE | DATE | APPROV | | DATE | | |

| | | | |
|----------|-------------------|---------------|--------|
| CUSTOMER | CUSTOMER APPROVAL | CUST PART NO. | SD04 |
| | | SECTION NO. | X86471 |

頂框

- a=0.1r
- b=0.2r
- c=0.3r
- d=0.4r
- e=0.5r
- f=0.8r
- g=1.0r
- h=1.5r

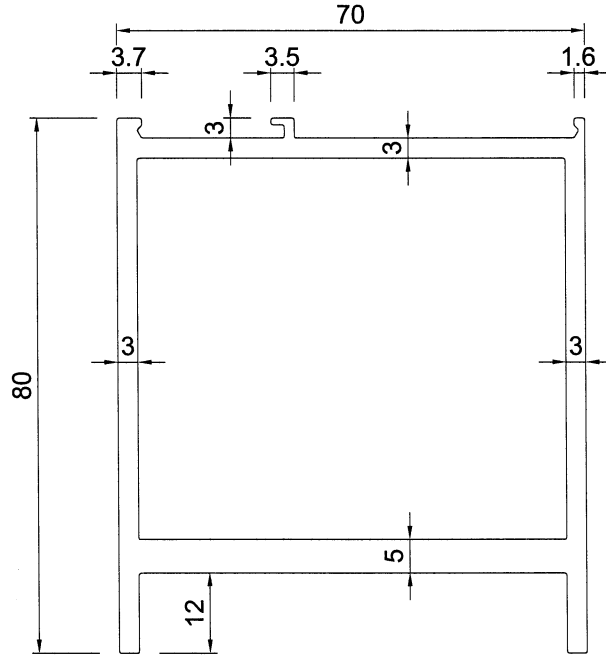

| | |
|----------|------------|
| 美特鋁質有限公司 | |
| 承認圖面 | |
| 日期 | 20/09/2023 |

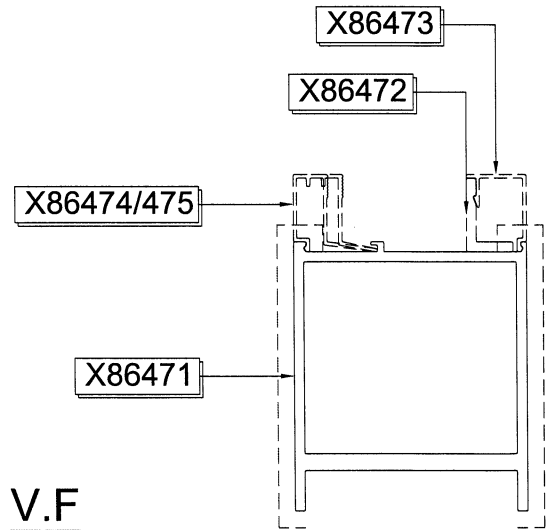

V.F

SCALE 1:2

| | | | | | | | | | |
|--------------------|-------------------------|-----------------------|------------------|----------------|--------|------------|------------|---------|-----|
| SIGNATURE GRADEING | HIGH SIGNATURE GRADEING | C.C.DIA(MM) | 106.3 | | | | | | |
| AREA (SQ MM) | 996.6 | UNSPECIFIED THICKNESS | - | PERIMETER (MM) | 338.66 | STANDARD | | SCALE | 1:1 |
| MASS (KG/M) | 2.701 | UNSPECIFIED CORNERS | - | SURFACE AREA | 265.11 | ALLOY | 6063-T6 | VERSION | |
| COMPANY ISSUE | | | DRAWA | DZL | DATE | 2021-09-09 | APELLATION | PAGE OF | |
| | | | STANDA-RDIZATION | | DATE | | | | |
| | | | TO SIGN | | DATE | | | | |
| | | | AUDITING | | DATE | | | | |
| MARKER | MODIFY | FILE NO | SIGNATURE | DATE | APPROV | | DATE | | |

美特鋁質有限公司
MIDI Aluminium Fabricator Ltd.

T:\Jobs\48305_新圖\圖面\頂框圖.dwg, 2023/09/20 10:13:50, \\192.168.1.101\Public\ApeosForm\IV 6080

| | | | |
|----------|-------------------|---------------|--------|
| CUSTOMER | CUSTOMER APPROVAL | CUST PART NO. | SDA05 |
| | | SECTION NO. | X86472 |

鋁角

a=0.1r
b=0.2r
c=0.3r
d=0.4r
e=0.5r
f=0.8r
g=1.0r
h=1.5r

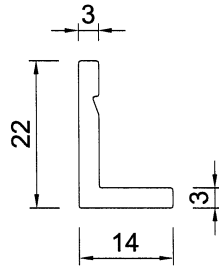

SCALE 1:1

| | |
|----------|------------|
| 美特鋁質有限公司 | |
| 承認圖面 | |
| 日期 | 20/09/2023 |

| | | | | | | | | | |
|--------------------|-------------------------|-----------------------|------------------|----------------|--------|------------|------------|---------|-----|
| SIGNATURE GRADEING | HIGH SIGNATURE GRADEING | C.C.DIA(MM) | 26.1 | | | | | | |
| AREA (SQ MM) | 97.6 | UNSPECIFIED THICKNESS | - | PERIMETER (MM) | 72 | STANDARD | | SCALE | 1:1 |
| MASS (KG/M) | 0.265 | UNSPECIFIED CORNERS | - | SURFACE AREA | - | ALLOY | 6063-T6 | VERSION | |
| COMPANY ISSUE | | | DRAWA | DZL | DATE | 2021-09-09 | APELLATION | PAGE OF | |
| | | | STANDA-RDIZATION | | DATE | | | | |
| | | | TO SIGN | | DATE | | | | |
| | | | AUDITING | | DATE | | | | |
| MARKER | MODIFY | FILE NO | SIGNATURE | DATE | APPROV | | DATE | | |

美特鋁質有限公司
MIDI Aluminium Fabricator Ltd.

| | | | |
|----------|-------------------|---------------|--------|
| CUSTOMER | CUSTOMER APPROVAL | CUST PART NO. | SDB06 |
| | | SECTION NO. | X86473 |

a=0.1r
b=0.2r
c=0.3r
d=0.4r
e=0.5r
f=0.8r
g=1.0r
h=1.5r

拍線

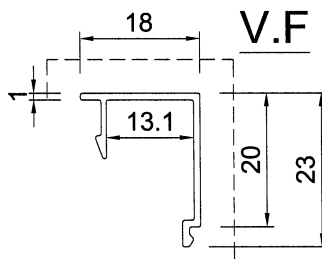

SCALE 1:1

| | |
|----------|--------------------|
| 美特鋁質有限公司 | |
| 承認圖面 | <i>[Signature]</i> |
| 日期 | 20/09/2023 |

| | | | | | | | | | |
|--------------------|-------------------------|-----------------------|------------------|----------------|--------|------------|------------|---------|-----|
| SIGNATURE GRADEING | HIGH SIGNATURE GRADEING | C.C.DIA(MM) | 29.2 | | | | | | |
| AREA (SQ MM) | 50.5 | UNSPECIFIED THICKNESS | - | PERIMETER (MM) | 102.2 | STANDARD | | SCALE | 1:1 |
| MASS (KG/M) | 0.137 | UNSPECIFIED CORNERS | - | SURFACE AREA | 61.32 | ALLOY | 6063-T5 | VERSION | |
| COMPANY ISSUE | | | DRAWA | DZL | DATE | 2021-09-09 | APELLATION | PAGE OF | |
| | | | STANDA-RDIZATION | | DATE | | | | |
| | | | TO SIGN | | DATE | | | | |
| | | | AUDITING | | DATE | | | | |
| MARKER | MODIFY | FILE NO | SIGNATURE | DATE | APPROV | | DATE | | |

美特鋁質有限公司
MIDI Aluminium Fabricator Ltd.

| | | | |
|----------|-------------------|---------------|--------|
| CUSTOMER | CUSTOMER APPROVAL | CUST PART NO. | SDB07 |
| | | SECTION NO. | X86474 |

a=0.1r
b=0.2r
c=0.3r
d=0.4r
e=0.5r
f=0.8r
g=1.0r
h=1.5r

拍線

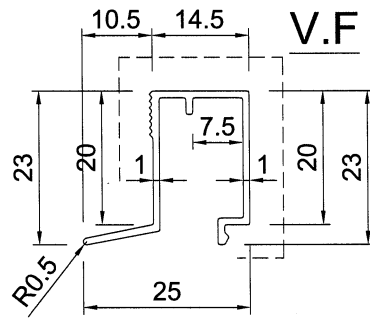

SCALE 1:1

| | |
|----------|------------|
| 美特鋁質有限公司 | |
| 承認圖面 | 6 |
| 日期 | 20/09/2023 |

| | | | | | | | | |
|--------------------|-------------------------|-----------------------|------------------|----------------|--------|------------|------------|---------|
| SIGNATURE GRADEING | HIGH SIGNATURE GRADEING | C.C.DIA(MM) | 34.0 | | | | | |
| AREA (SQ MM) | 76.4 | UNSPECIFIED THICKNESS | - | PERIMETER (MM) | 148.3 | STANDARD | SCALE | 1:1 |
| MASS (KG/M) | 0.21 | UNSPECIFIED CORNERS | - | SURFACE AREA | 89.0 | ALLOY | 6063-T5 | VERSION |
| COMPANY ISSUE | | | DRAWA | DZL | DATE | 2021-09-09 | APELLATION | PAGE OF |
| | | | STANDA-RDIZATION | | DATE | | | |
| | | | TO SIGN | | DATE | | | |
| | | | AUDITING | | DATE | | | |
| MARKER | MODIFY | FILE NO | SIGNATURE | DATE | APPROV | | | |

 美特鋁質有限公司
MIDI Aluminium Fabricator Ltd.

| | | | |
|----------|-------------------|---------------|--------|
| CUSTOMER | CUSTOMER APPROVAL | CUST PART NO. | SDB08 |
| | | SECTION NO. | X86475 |

$a=0.1r$
 $b=0.2r$
 $c=0.3r$
 $d=0.4r$
 $e=0.5r$
 $f=0.8r$
 $g=1.0r$
 $h=1.5r$

拍線

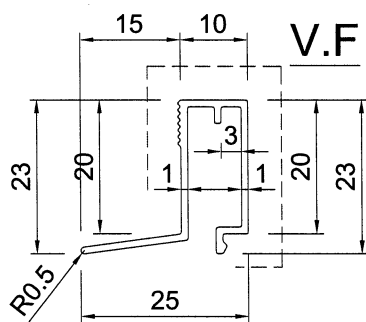

| | |
|----------|--------------------|
| 美特鋁質有限公司 | |
| 承認圖面 | <i>[Signature]</i> |
| 日期 | 20/09/2023 |

SCALE 1:1

| | | | | | | | | | |
|--------------------|-------------------------|-----------------------|------------------|----------------|--------|------------|------------|---------|-----|
| SIGNATURE GRADEING | HIGH SIGNATURE GRADEING | C.C.DIA(MM) | 34.0 | | | | | | |
| AREA (SQ MM) | 76.2 | UNSPECIFIED THICKNESS | - | PERIMETER (MM) | 148.2 | STANDARD | | SCALE | 1:1 |
| MASS (KG/M) | 0.21 | UNSPECIFIED CORNERS | - | SURFACE AREA | 89.0 | ALLOY | 6063-T5 | VERSION | |
| COMPANY ISSUE | | | DRAWA | DZL | DATE | 2021-09-09 | APELLATION | PAGE OF | |
| | | | STANDA-RDIZATION | | DATE | | | | |
| | | | TO SIGN | | DATE | | | | |
| | | | AUDITING | | DATE | | | | |
| MARKER | MODIFY | FILE NO | SIGNATURE | DATE | APPROV | | | | |

美特鋁質有限公司
 MIDI Aluminium Fabricator Ltd.

