

工程指示 / 要求簡箋(E.I.)

工程指示編號：EI / 3533 / 21

修改版次：B

工程編號：J - 852

工程名稱：亞皆老街中電

工程項目：佛沙窗 地盤用玻璃 B.M. 大貨 (T1-T3: 22-23/F) (32 件) 磨砂玻璃 暫停

收件人：Maggie

發件人：Ant Yeung

日期：16/07/2021

要求提供 / 確認 事項：

- | | | |
|------------------------------------|-------------------------------------|-------------------------------|
| <input type="checkbox"/> 初步鋁料 B.M. | <input type="checkbox"/> 加工拆圖，然後生產 | <input type="checkbox"/> 尺寸表 |
| <input type="checkbox"/> 正式鋁料 B.M. | <input type="checkbox"/> 技術上資料 / 指示 | <input type="checkbox"/> 報價 |
| <input type="checkbox"/> 配件 B.M. | <input type="checkbox"/> 樣辦或貨品說明書 | <input type="checkbox"/> 分判合約 |
| <input type="checkbox"/> 其他：_____ | | |

內容：`

B 版：因顧問拒絕批核 acid etched 磨砂玻璃。現暫停生產所有磨砂玻璃。此單暫停。

A 版：則師要求修改磨砂玻璃位置。請按 BM 訂購 T1-T3: 22-23/F 磨砂玻璃 (共 32 件)。

業主要求浴室玻璃更改為磨砂玻璃，請按 BM 訂購 T1-T3: 22-23/F 浴室磨砂玻璃 (共 27 件)

(T1:6 件. T2: 15 件. T3:6 件)直送地盤。

IGU 膠用 DC983 結構膠

玻璃要做熱浸。 Low-E: SEE0-83T.

請留意玻璃加工時不要固定的鋼化及熱浸標籤。玻璃出貨時需加上"可移除" 標籤。

IGU: 標籤在室內外面 (注明半鋼化/ 鋼化)

請在 2021.07.16 前完成上列要求。

附：12 頁 MFT Comment

以上項目為：

- 原合約工程包 原合約工程加 / 減賬 新工程報價

原因：-

分發東莞各部門：

- | | | | |
|-------------------------------------|------------------------------------|------------------------------------|---|
| <input type="checkbox"/> 生產技術總監口連附件 | <input type="checkbox"/> 技術部 口連附件 | <input type="checkbox"/> 生產部 口連附件 | <input type="checkbox"/> 機械設計部口連附件 |
| <input type="checkbox"/> 採購部 口連附件 | <input type="checkbox"/> 生產統籌部口連附件 | <input type="checkbox"/> 小羅&清 口連附件 | |
| <input type="checkbox"/> 質檢部 口連附件 | <input type="checkbox"/> 會計部 口連附件 | <input type="checkbox"/> 報關組 口連附件 | <input type="checkbox"/> 其他 <u>楊榮輝</u> 口連附件 |

分發其他分判：

- 水洪 口連附件

分發香港各部門：

- | | | | | |
|---|------------------------------------|----------------------------------|---|----|
| <input type="checkbox"/> 行政部口連附件 | <input type="checkbox"/> 會計部口連附件 | <input type="checkbox"/> 統籌部口連附件 | <input checked="" type="checkbox"/> 工程部地盤科文口連附件 | 祥哥 |
| <input checked="" type="checkbox"/> 採購部口連附件 | <input type="checkbox"/> QS 部 口連附件 | <input type="checkbox"/> 維修部口連附件 | <input type="checkbox"/> 其他 _____ 口連附件 | |

傳遞編號：

發件人簽署： Ant Yeung

HK / 21

項目經理簽署： Ant Yeung

MATERIAL / SAMPLE SUBMISSION FORM
**To : Mr Brian Leung / Mr Nigel Lo / Ms Eunice Yan
Meinhardt Façade Technology (HK) Ltd
22/F Great Smart Tower,
230 Wanchai Road,
Wan Chai, Hong Kong**

No. MS/A/334 (Rev. 0)

Date: 28 May 2021

REQUIRED APPROVAL DATE: 11 June 2021

Ref. J3860/304.6/D10245

We submit the following material for your comment / approval by the date indicated above.

 Sub-Contractor / Trade: Midi Aluminium Fabrication Ltd/ Curtain Wall, Aluminium Windows and Louvres, Aluminium Cladding and Glass Balustrade

 Material Description: Submission of Glass Samples for Bulk Order - Acid Etched Glass for Tower (MS083)
 Comply fully w/ Specification MFT's specification **Not comply fully with Specification (Deviation Listed herein)** N.A.

Equipment Originally Offered

 Type : N.A.
 Manufacturer : N.A.
 Origin : N.A.
 Model No : N.A.

Equipment Offer

 Type : Glass
 Manufacturer : Avic Sanxin
 Origin : China
 Model No : Refer to attachment

 Reason for change if any : N.A.
Location for use: Windows for 1 - 23/F Bathroom, 22 - 23/F Master Ensuite as per attached marked up
Enclosures: Catalogue Data / Specification Certificate / Approval
 Test Report Material Sample Installation Drawing
 Job Reference Schedule Other (specify):

Remarks: There are 2 sets of sample kept on site for review and approval.

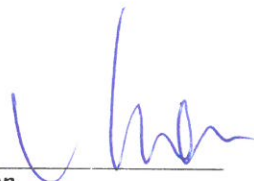
 Dick Yuen Senior Project Manager Gammon Engineering & Construction Company Limited DY/JM/CK/PC/wym	cc <input checked="" type="checkbox"/> Pacific Shine - Mr Billy Tang / Mr Kocher Wong / Mr Edwin Chow / Mr Simon Chung / Mr Ross Pau / Mr Ken Ng / Mr Wyman Fong / Mr Jimmy Cheung / Mr C F Lee / Mr Peter Chong <input checked="" type="checkbox"/> AGC - Ms Grace Cheng / Mr Raymond Ho <input type="checkbox"/> ARUP (Stru) - Mr Johnson Po / Mr Keith Ng / Mr Wayne Ke / Mr Andrew Tai <input type="checkbox"/> W&O - Mr Nier Chan / Mr Anson Lau <input checked="" type="checkbox"/> Arcadis - Ms Brenda Mok / Ms Emily Chu <input type="checkbox"/> AXXA - Ms Siuman Hung / Ms Sammy Tang / Mr Oscar Leung / Ms Yvonne Yau <input type="checkbox"/> ARUP (Traffic) - Ms Carmen Chu / Mr Eddy Cheung <input type="checkbox"/> WSP - Ms Anthea Ng / Mr Dennis Tse <input type="checkbox"/> Ramboll - Mr Calvin Chiu / Mr Peter Leung / Mr Alvin Chan <input type="checkbox"/> RE - Mr Edwin Lui / Mr Raymond Hui / Mr Jayden Wong <input checked="" type="checkbox"/> MFT RE - Ms Cosimo Wong / Mr Neo Wong <input checked="" type="checkbox"/> OSR - Mr H T Tseung / Mr Poon Tsz Kit / Mr Jaja Wong / Mr Elvis Lam <input type="checkbox"/> BSI (Sino) - Mr Kelvin Tam <input type="checkbox"/> RBSE (W&O) - Mr Kevin Lee <input checked="" type="checkbox"/> S/C - Midi (By Email)
--	--

Encl

Architect's / Consultant's Reply
 Approved (A) Approved with comment (B) Approved with comment & resubmit (C) Rejected (D)

Comments : Coatings of glass shall be referred to facade specification.

 Signed : PP = Yuen Designation : MFT Date : 14 Jul 2021

 Remarks : w/encl. w/o encl



美特鋁質有限公司
MIDI ALUMINIUM FABRICATOR LTD.

Our ref. MC/40172/852

26th May 2021

Gammon Engineering & Construction Company Limited
139 - 147 Argyle Street,
Kowloon, Hong Kong

By Email & Hand

Attn.: Mr. Dick Yuen / Ms. Penny Chau

Dear Sir,

Re : Design, Supply & Installation of Aluminium Window & Cladding, Curtain Wall, Glass Wall, Louvers and Glass Balustrade Nominated Sub-Contract at K.I.L. 6038RP, K.I.L.6037RP, K.I.L. 6036RP, K.I.L. 6035RP & K.I.L. 6005, Nos. 139-147 Argyle Street, Kowloon.

Submission of Glass Samples for Bulk Order - Acid Etched Glass for Tower (MS083)

Further to the captioned project, we would like to submit acid etched glass samples for bulk order for your review and comment.

- 1) 8mm low-iron HS (with low-e coating in light grey colour at surface #2) + 12mm Air Gap + 10mm low-iron HST (acid etched at surface #3)
Sample Code : D21041726 (8SEE0-83T (HS)+12A+10CBYP)
Location: Fixed Windows - 1~23/F Bathroom, 22~23/F Master Ensuite
- 2) 6mm low-iron HS (with low-e coating in light grey colour at surface #2) + 12mm Air Gap + 6mm low-iron HST (acid etched at surface #3)
Sample Code : D21041725 (6SEE0-83T (HS)+12A+6CBYP)
Location: Openable Windows - 1~23/F Bathroom, 22~23/F Master Ensuite

We would deliver glass samples to site and each type of glass sample would be submitted in 2 sets. For details, please refer to the attached location plan, glass data and sample photos.

Thank you for your kind attention.

Yours faithfully,
MIDI ALUMINIUM FABRICATOR LTD.

Francis Mau
Managing Director

Encl

cc. Gammon	- Mr. Chris Kwok / Ms. Myra Li / - Ms. Esther Chung / Mr. Sam Tang / - Mr. Jackson Mok /	(w/e)
Sino	- Mr. Billy Tang / Mr. Jimmy Cheung / - Mr. Terry Wan / Mr. Jaja Wong	(w/e) (Email Only)
AGC	- Mr. Raymond Ho / Mr. Eliot Chan	(w/e) (Email Only)
Arup	- Mr. Edwin Lui / Mr. Andrew Tai	(w/e) (Email Only)
MFT	- Mr. Brian Leung / Mr. Nigel Lo - Ms. Eunice Yan / Ms. Cosimo Wong / Mr. Neo Wong	(w/e) (Email Only)

九龍茶葉嶺道610號生利工業中心1樓6-8號

Units 6-8, 1st Floor, Sunray Industrial Centre, 610 Cha Kwo Ling Road, Kln.

TEL. (電話) : 2348 9211 FAX. (傳真) : 2772 7666 E-mail Address (電郵) : midi@midiltd.com.hk.



ISO 9001 : 2015
Certificate No: CC 1795



MIDI ALUMINIUM FABRICATOR LTD.

Units 6, 7, 8 Sunray Industrial Centre, 1st Floor, 610 Cha Kwo Ling Road Kowloon.

Project : Nos. 139-147 Argyle Street, Kowloon.

Subject : Glass Samples for Bulk Order - Acid Etched Glass for Tower (MS083)

6mm low-iron HS (with low-e coating in light grey colour at surface #2) +
12mm Air Gap + 6mm low-iron HST (acid etched at surface #3)

Sample Code : D21041725 (6SEED-83T (HS)+12A+6CBYP)

Location : Openable Windows - 1-23/F Bathroom, 22-23/F Master Ensuite

Letter ref. : MC/40172/852

Date : 26th May 2021

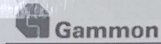

J3860 - Proposed Residential Development, At 139 – 147 Argyle Street, Kowloon

Submission Ref. no.:	MC/ 40172 /852	Authorized Representative:	<input type="checkbox"/> Pacific Shine <input type="checkbox"/> AGC <input type="checkbox"/> ARUP <input type="checkbox"/> WOY	<input type="checkbox"/> MFT <input type="checkbox"/> AXXA <input type="checkbox"/> <input type="checkbox"/>
Material Description:	Submission of Glass Samples for Bulk Order - Acid Etched Glass for Tower (MS083)	Name:		
Submission Date:	26/05/2021	Signature:		
Approval Date:		Signature Date:		
Comment:				





MIDI ALUMINIUM FABRICATOR LTD.

Units 6, 7, 8 Survey Industrial Centre, 1st Floor, 610 Che Kwo Ling Road, Kowloon.

Project : Nos. 139-147 Argyle Street, Kowloon

Subject : Glass Samples for Bulk Order - Acid Etched Glass for Tower (MS083)

Notes: low-iron ISG (with low-e coating in light grey colour at surface #2) -
12mm Air Gap - 10mm low-iron HST (acid etched at surface #1)

Sample Code : D21041726 (KSEEN-KYT (125)-124-10C18V9)

Location : Fixed Windows - 1-25/F Bathroom, 22-25/F Master Bedroom

Letter ref : MC/40172/852

Date : 26th May 2021



Gammon

J3860 - Proposed Residential Development, At 139 - 147 Argyle Street, Kowloon

Submission Ref. no.:	MC/ 40172 /852	Authorized Representative:	<input type="checkbox"/> Pacific Shine <input type="checkbox"/> AGC <input type="checkbox"/> ARUP <input type="checkbox"/> WOY	<input type="checkbox"/> MFT <input type="checkbox"/> AXXA <input type="checkbox"/> <input type="checkbox"/>
Material Description:	Submission of Glass Samples for Bulk Order - Acid Etched Glass for Tower (MS083)	Name:		
Submission Date:	26/05/2021	Signature:		
Approval Date:		Signature Date:		
Comment:				



玻璃性能参数

PHOTOMETRIC PROPERTIES

客户名称：美特

项目名： 亚皆老街中电

时间：20/5-2021

玻璃产品 Class Product	厚度 (毫米) Thickness (mm)	可见光 Light characteristics			太阳热能 Energy characteristics					U-值
		透光率 trans (%)	反光率Reflection		热直透率 trans (%)	热反射率 Reflection(%)	热吸收率 Abs (%)	热能系数 SolarFactor	遮阳系数 Shading Coefficient	U-Value
			外Out (%)	内In (%)						空气 (W/M ²)
L.T.	L.R.	L.R.	D.E.T	E.R	E.A.	S.F.	S.C.	AIR		
8mm low iron #2 SEE-83T+12A+10mm low iron #3 acid etched <i>D21041726</i>		77%	12%	12%	56%	24%	20%	0.59	0.68	1.73
6mm low iron #2 SEE-83T+12A+6mm low iron #3 acid etched <i>D21041725</i>		77%	12%	12%	56%	24%	20%	0.59	0.68	1.75

1. The performance data shown are nominal and subject to variations due to manufacturing tolerances.
2. A slight shift in visible light reflectance or transmission may be noticed after heat-treatment.
3. The tolerance of data with respect to photometric properties is ± 3 points.
4. The U-value tolerance is ± 0.1 W/m².k.
5. Specifications technical and other data are based on information available at the time of preparation this document and are subject to change without prior notice.
6. The above performance parameters calculated in accordance with WINDOW6 software.All data are just for your reference, not as an official contract.



NO. 107 / 10.1 / 2011 / 10 (A3)
 PD NO. 10.1 / 2011 / 10 (A3)

- LEGEND:**
- PRECAST FACADE
 - MAX 500mm SUMMER SLAB
 - CONTAINING ACCESS ROUTES FOR MAINTENANCE UNDER APP-93
 - AB * ACOUSTIC BALCONY
 - AD * ACOUSTIC DOOR (BATTLER TYPE)
 - AW * ACOUSTIC WINDOW
 - M * FIBRE GLASS / FIBRE GLASS WITH MAINTENANCE
 - SC * WITH SELF-CLOSING MECHANISM FOR L.L.S. DOOR
 - SA * SOUND ABSORPTIVE MATERIAL
 - OA * WINDOW OPERABLE AREA
 - AF * ARCHITECTURAL FEATURE

MAINTENANCE ACCESS BY SERVICE AS SHOWN

Wing Yan Yan
 WING Yan-yan
 Senior Building Surveyor
 for BUILDING AUTHORITY
 30 DEC 2019

Grace Chang
 Grace Chang
 for and on behalf of
 AGC Design Ltd.
 Authorized Person
 (List of Architects)

BD
AMENDED PLAN 02 DEC 2019

NO.	DESCRIPTION	DATE
A	BD RE-SUBMISSION	12.2011 CC
B	MAJOR AMENDMENT	03.2011 CC
C	MAJOR AMENDMENT	11.2011 CC
D	MINOR AMENDMENT	04.2013 CC
E	MINOR AMENDMENT	02.2013 CC
F	MINOR AMENDMENT	11.2013 CC
G	MAJOR AMENDMENT	07.2015 CC
H	AMENDMENT	01.2016 CC
J	AMENDMENT	07.2016 CC
K	AMENDMENT	10.2016 CC
L	AMENDMENT	12.2016 CC

AGC
DESIGN LTD

新加坡建築師有限公司
 181, Cross Street, 201, Singapore
 Tel: (65) 63371818 Fax: (65) 63371813 Email: agc@agc.com.sg

PROPOSED RESIDENTIAL DEVELOPMENT
 AT 139-147 ARGYLE STREET,
 KOWLOON INLAND LOT Nos. 6005,
 6035 R.P., 6036 R.P., 6037 R.P.
 & 6038 R.P.

FIRST FLOOR PLAN
 (1/F)

NO.	DATE	BY	CHK	APP	DATE
1	12/01/2011	WY	GC	GC	12/01/2011
2	03/01/2011	WY	GC	GC	03/01/2011
3	11/01/2011	WY	GC	GC	11/01/2011
4	04/01/2013	WY	GC	GC	04/01/2013
5	02/01/2013	WY	GC	GC	02/01/2013
6	11/01/2013	WY	GC	GC	11/01/2013
7	07/01/2015	WY	GC	GC	07/01/2015
8	01/01/2016	WY	GC	GC	01/01/2016
9	07/01/2016	WY	GC	GC	07/01/2016
10	10/01/2016	WY	GC	GC	10/01/2016
11	12/01/2016	WY	GC	GC	12/01/2016

THE WORKS SHOWN ON THESE PLANS ARE TYPE B WORKS (GENERAL BUILDING WORKS) IN RESPECT OF WHICH CONSENT IS APPLIED FOR THE PURPOSE OF FAST TRACK CONSENT APPLICATION UNDER REGULATION 33 OF THE BUILDING (CONSTRUCTION) REGULATIONS 2011.

FIRST FLOOR PLAN

SUPERPOSED SCALE: 1:200
 ALL DIMENSIONS SHOWN ON TYPICAL FLOOR (0.7 TO 21.7) UNLESS OTHERWISE STATED

PART PLAN OF PIPE WELL AT AREA OF PIPE DIA. 1500mm
 AREA OF VENTILATION CROWDING REQUIRED = 3.00sqm
 AREA OF OPEN LOUVER PROVIDED AT TOP A WIDTH OF PIPE DIA. WELL = 0.96 x 0.96 = 0.9216 sqm

KEY PLAN FOR TYPICAL DETAIL OF TRANSFER PLATE



Plan Approved
 WONG Yan van
 Senior Building Surveyor
 for BUILDING AUTHORITY
 30 DEC 2019

LEGEND:

- PRECAST FACADE
- MAX. 300mm SUNKEN SLAB
- COMMON ACCESS ROUTES FOR MAINTENANCE UNDER APP-93
- ACUSTIC BALCONY
- ACUSTIC DOOR (BATTLER TYPE)
- ACUSTIC WINDOW
- FIXED GLAZING / FIXED GLAZING WITH MAINTENANCE WITH SELF-CLOSING MECHANISM FOR U.P. DOOR
- SOUND ABSORBING MATERIAL
- WINDOW OPERABLE AREA
- ARCHITECTURAL FEATURE

FLOOR	H (B.F.L.)	FLOOR	H (B.F.L.)
2/F	38.800	11/F	55.820
3/F	41.200	12/F	57.180
4/F	43.500	13/F	58.540
5/F	45.800	14/F	59.900
6/F	48.100	15/F	61.260
7/F	50.400	16/F	62.620
8/F	52.700	17/F	63.980
9/F	55.000	18/F	65.340
10/F	57.300	19/F	66.700
20/F	86.540	21/F	87.900

Grace Cheng
 Cheung Yan Ying Grace
 for and on behalf of
 AGC Design Ltd.

Authorized Person
 (List of Architects)
BD
AMENDED PLAN 02 DEC 2019

REVISION	DESCRIPTION	DATE
A	90 RE-SUBMISSION	NRK 02.2019 CC
B	MAJOR AMENDMENT	NRK 03.2019 CC
C	MAJOR AMENDMENT	NRK 11.2019 CC
D	MAJOR AMENDMENT	NRK 4.2019 CC
E	MINOR AMENDMENT	NRK 5.2019 CC
F	MINOR AMENDMENT	NRK 7.2019 CC
G	AMENDMENT	SN 02.2019 CC
H	AMENDMENT	SN 7.2019 CC
I	AMENDMENT	AC 02.019 CC
K	AMENDMENT	AC 12.2019 CC

AGC
 DESIGN LTD

AGC DESIGN LTD
 11/F, 118, Des Voeux Road, 22/F, 118, Des Voeux Road, Hong Kong
 Tel: (852) 2778 1788 Fax: (852) 2778 1722 Email: agc@agcdesign.com.hk

PROPOSED RESIDENTIAL DEVELOPMENT
 AT 139-147 ARGYLE STREET, 4/F
 KOWLOON INLAND LOT Nos. 6005,
 6035, R.P. 6038, R.P. 6037, R.P.
 & 6038, R.P. 6038, R.P. 6037 and the portion of
 land within 6037 and the portion of
 land within 6038, 6037 and 6038.

TYPICAL FLOOR PLAN
 (2/F to 21/F)
 (SHEET 1)

2/F - 21/F PLAN FOR TOWER 2 & TOWER 3
 OF 139 & 147 TO BE DATED
 SUPPLEMENT 130 - 130A

"THE WORKS SHOWN ON THESE PLANS ARE TYPE II
 WORKS (GENERAL BUILDING WORKS) IN RESPECT OF
 WHICH CONSENT IS APPLIED FOR THE PURPOSE OF FAST
 TRACK CONSENT APPLICATION UNDER REGULATION 33 OF
 THE BUILDING (ADMINISTRATIVE) REGULATIONS."

DATE	1:00	DATE	10/10/2019	CD	AC-01-08-09
DRW	NRK	CHK	NRK	CHK	NRK
DRW	NRK	CHK	NRK	CHK	NRK

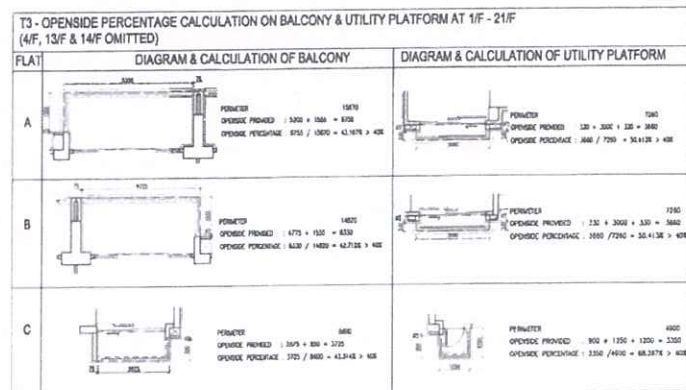
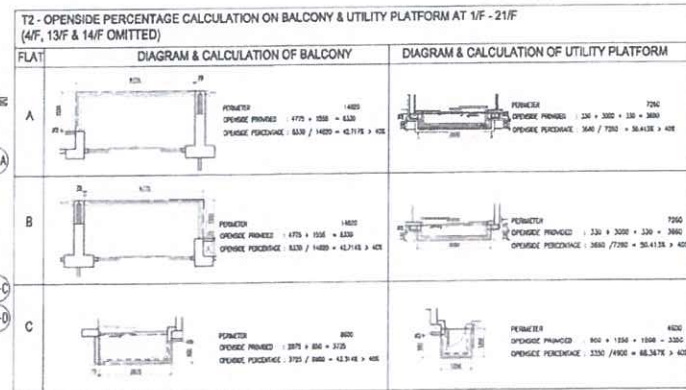
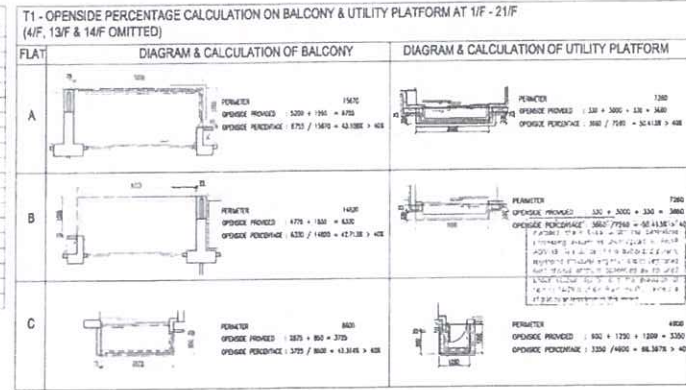
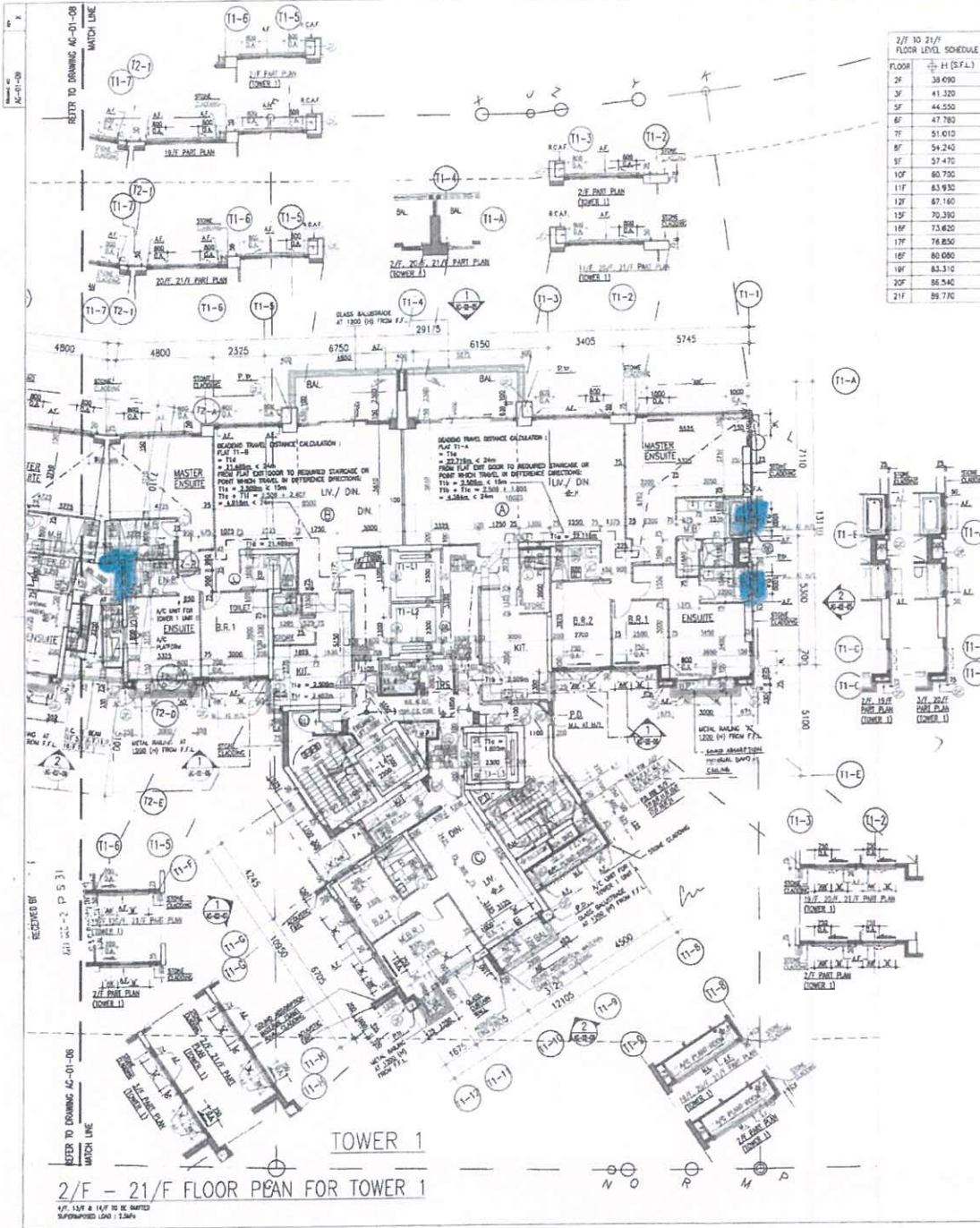

LEGEND:

- PHILDS' FACADE
- MAX 500mm SUNKEN SLAB
- COMMONAL ACCESS ROUTES FOR MAINTENANCE LADDER APP-93
- AB' ACUSTIC BALCONY
- AD' ACUSTIC DOOR (BATTLE TYPE)
- AW' ACUSTIC WINDOW
- M' FIXED GLAZING FIELD GLAZING WITH MAINTENANCE
- SC' WITH SELF-CLOSING MECHANISM FOR HELP SCOR
- SA' SOUND ABSORBENT MATERIAL
- QA' WINDOW OPENABLE AREA
- AF' ARCHITECTURAL FEATURE

Plan Approved *[Signature]*
WONG Yan-Yan
 Senior Building Surveyor
 for BUILDING AUTHORITY
 30 DEC 2019

Cheng Chung
 Cheng Yan Ying Group
 for and on behalf of
 AGC Design Ltd
 Authorized Person
 (List of Architects)
BD
 AMENDED PLAN 02 DEC 2019

REVISION	DESCRIPTION	BY	DATE	APPROVED
A	BD RE-SUBMISSION	WPK	02.2019	CC
B	MAJOR AMENDMENT	WPK	03.2019	CC
C	MAJOR AMENDMENT	WPK	11.2019	CC
D	MINOR AMENDMENT	WPK	03.2019	CC
E	MINOR AMENDMENT	WPK	05.2019	CC
F	MAJOR AMENDMENT	WPK	07.2019	CC
G	AMENDMENT	SM	03.2019	CC
H	AMENDMENT	SM	07.2019	CC
J	AMENDMENT	WPK	09.2019	CC
K	AMENDMENT	AC	12.2019	CC

AGC DESIGN LTD

AGC DESIGN LIMITED
 11/F, 12/F, 13/F, 14/F, 15/F, 16/F, 17/F, 18/F, 19/F, 20/F, 21/F, 22/F, 23/F, 24/F, 25/F, 26/F, 27/F, 28/F, 29/F, 30/F, 31/F, 32/F, 33/F, 34/F, 35/F, 36/F, 37/F, 38/F, 39/F, 40/F, 41/F, 42/F, 43/F, 44/F, 45/F, 46/F, 47/F, 48/F, 49/F, 50/F, 51/F, 52/F, 53/F, 54/F, 55/F, 56/F, 57/F, 58/F, 59/F, 60/F, 61/F, 62/F, 63/F, 64/F, 65/F, 66/F, 67/F, 68/F, 69/F, 70/F, 71/F, 72/F, 73/F, 74/F, 75/F, 76/F, 77/F, 78/F, 79/F, 80/F, 81/F, 82/F, 83/F, 84/F, 85/F, 86/F, 87/F, 88/F, 89/F, 90/F, 91/F, 92/F, 93/F, 94/F, 95/F, 96/F, 97/F, 98/F, 99/F, 100/F

PROPOSED RESIDENTIAL BUILDING AT 139-147 ARGYLE STREET, KOWLOON INLAND LOT Nos. 6005, 6035 R.P., 6036 R.P., 6037 R.P. & 6038 R.P.

TYPICAL FLOOR PLAN (2/F TO 21/F) (SHEET 2)

THE WORKS SHOWN ON THESE PLANS ARE TYPE II WORKS (GENERAL BUILDING WORKS) IN RESPECT OF WHICH CONSENT IS APPLIED FOR THE PURPOSE OF FAST TRACK CONSENT APPLICATION UNDER REGULATION 33 OF THE BUILDING (ADMINISTRATION) REGULATIONS.

DATE: 11/08/2019
 DRAWN BY: WPK
 CHECKED BY: WPK
 DATE: 11/08/2019

ISSUED FOR CONSTRUCTION
A.I. NO. A1-MC-0075
5 JAN 2021

- LEGEND:
- FRENCH FINISH
 - MAX. 500mm SURVEY SLAB
 - COMMON ACCESS ROUTES FOR MAINTENANCE UNDER APP-93
 - AB - ACOUSTIC SCREEN
 - AD - ACOUSTIC DOOR (BUFFLE TYPE)
 - AW - ACOUSTIC WINDOW
 - M - FIBRE GLASS / FINED GLAZING WITH MAINTENANCE
 - SC - WITH SELF-CLOSING MECHANISM FOR W.P. DOOR
 - O.A. - WINDOW OPERABLE AREA
 - A.F. - ARCHITECTURAL FEATURE

Cheng Yung
Cheng Yung Gricen
for and on behalf of
AGC Design Ltd
Authorized Person
(List of Architects)

BD AMENDED PLAN 14 AUG 2020

REVISION	DESCRIPTION	DATE
A	BD RE-SUBMISSION	08/02/2019 CC
B	MAJOR AMENDMENT	14/03/2019 CC
C	MAJOR AMENDMENT	11/04/2019 CC
D	MAJOR AMENDMENT	04/20/19 CC
E	MAJOR AMENDMENT	05/21/19 CC
F	MAJOR AMENDMENT	07/22/19 CC
G	AMENDMENT	08/20/19 CC
H	AMENDMENT	07/20/19 CC
I	AMENDMENT	10/20/19 CC
J	AMENDMENT	12/20/19 CC
K	AMENDMENT	08/20/20 CC

AGC DESIGN LTD

AGC DESIGN LTD
111, 113, 115, 117, 119, 121, 123, 125, 127, 129, 131, 133, 135, 137, 139, 141, 143, 145, 147, 149, 151, 153, 155, 157, 159, 161, 163, 165, 167, 169, 171, 173, 175, 177, 179, 181, 183, 185, 187, 189, 191, 193, 195, 197, 199, 201, 203, 205, 207, 209, 211, 213, 215, 217, 219, 221, 223, 225, 227, 229, 231, 233, 235, 237, 239, 241, 243, 245, 247, 249, 251, 253, 255, 257, 259, 261, 263, 265, 267, 269, 271, 273, 275, 277, 279, 281, 283, 285, 287, 289, 291, 293, 295, 297, 299, 301, 303, 305, 307, 309, 311, 313, 315, 317, 319, 321, 323, 325, 327, 329, 331, 333, 335, 337, 339, 341, 343, 345, 347, 349, 351, 353, 355, 357, 359, 361, 363, 365, 367, 369, 371, 373, 375, 377, 379, 381, 383, 385, 387, 389, 391, 393, 395, 397, 399, 401, 403, 405, 407, 409, 411, 413, 415, 417, 419, 421, 423, 425, 427, 429, 431, 433, 435, 437, 439, 441, 443, 445, 447, 449, 451, 453, 455, 457, 459, 461, 463, 465, 467, 469, 471, 473, 475, 477, 479, 481, 483, 485, 487, 489, 491, 493, 495, 497, 499, 501, 503, 505, 507, 509, 511, 513, 515, 517, 519, 521, 523, 525, 527, 529, 531, 533, 535, 537, 539, 541, 543, 545, 547, 549, 551, 553, 555, 557, 559, 561, 563, 565, 567, 569, 571, 573, 575, 577, 579, 581, 583, 585, 587, 589, 591, 593, 595, 597, 599, 601, 603, 605, 607, 609, 611, 613, 615, 617, 619, 621, 623, 625, 627, 629, 631, 633, 635, 637, 639, 641, 643, 645, 647, 649, 651, 653, 655, 657, 659, 661, 663, 665, 667, 669, 671, 673, 675, 677, 679, 681, 683, 685, 687, 689, 691, 693, 695, 697, 699, 701, 703, 705, 707, 709, 711, 713, 715, 717, 719, 721, 723, 725, 727, 729, 731, 733, 735, 737, 739, 741, 743, 745, 747, 749, 751, 753, 755, 757, 759, 761, 763, 765, 767, 769, 771, 773, 775, 777, 779, 781, 783, 785, 787, 789, 791, 793, 795, 797, 799, 801, 803, 805, 807, 809, 811, 813, 815, 817, 819, 821, 823, 825, 827, 829, 831, 833, 835, 837, 839, 841, 843, 845, 847, 849, 851, 853, 855, 857, 859, 861, 863, 865, 867, 869, 871, 873, 875, 877, 879, 881, 883, 885, 887, 889, 891, 893, 895, 897, 899, 901, 903, 905, 907, 909, 911, 913, 915, 917, 919, 921, 923, 925, 927, 929, 931, 933, 935, 937, 939, 941, 943, 945, 947, 949, 951, 953, 955, 957, 959, 961, 963, 965, 967, 969, 971, 973, 975, 977, 979, 981, 983, 985, 987, 989, 991, 993, 995, 997, 999, 1001, 1003, 1005, 1007, 1009, 1011, 1013, 1015, 1017, 1019, 1021, 1023, 1025, 1027, 1029, 1031, 1033, 1035, 1037, 1039, 1041, 1043, 1045, 1047, 1049, 1051, 1053, 1055, 1057, 1059, 1061, 1063, 1065, 1067, 1069, 1071, 1073, 1075, 1077, 1079, 1081, 1083, 1085, 1087, 1089, 1091, 1093, 1095, 1097, 1099, 1101, 1103, 1105, 1107, 1109, 1111, 1113, 1115, 1117, 1119, 1121, 1123, 1125, 1127, 1129, 1131, 1133, 1135, 1137, 1139, 1141, 1143, 1145, 1147, 1149, 1151, 1153, 1155, 1157, 1159, 1161, 1163, 1165, 1167, 1169, 1171, 1173, 1175, 1177, 1179, 1181, 1183, 1185, 1187, 1189, 1191, 1193, 1195, 1197, 1199, 1201, 1203, 1205, 1207, 1209, 1211, 1213, 1215, 1217, 1219, 1221, 1223, 1225, 1227, 1229, 1231, 1233, 1235, 1237, 1239, 1241, 1243, 1245, 1247, 1249, 1251, 1253, 1255, 1257, 1259, 1261, 1263, 1265, 1267, 1269, 1271, 1273, 1275, 1277, 1279, 1281, 1283, 1285, 1287, 1289, 1291, 1293, 1295, 1297, 1299, 1301, 1303, 1305, 1307, 1309, 1311, 1313, 1315, 1317, 1319, 1321, 1323, 1325, 1327, 1329, 1331, 1333, 1335, 1337, 1339, 1341, 1343, 1345, 1347, 1349, 1351, 1353, 1355, 1357, 1359, 1361, 1363, 1365, 1367, 1369, 1371, 1373, 1375, 1377, 1379, 1381, 1383, 1385, 1387, 1389, 1391, 1393, 1395, 1397, 1399, 1401, 1403, 1405, 1407, 1409, 1411, 1413, 1415, 1417, 1419, 1421, 1423, 1425, 1427, 1429, 1431, 1433, 1435, 1437, 1439, 1441, 1443, 1445, 1447, 1449, 1451, 1453, 1455, 1457, 1459, 1461, 1463, 1465, 1467, 1469, 1471, 1473, 1475, 1477, 1479, 1481, 1483, 1485, 1487, 1489, 1491, 1493, 1495, 1497, 1499, 1501, 1503, 1505, 1507, 1509, 1511, 1513, 1515, 1517, 1519, 1521, 1523, 1525, 1527, 1529, 1531, 1533, 1535, 1537, 1539, 1541, 1543, 1545, 1547, 1549, 1551, 1553, 1555, 1557, 1559, 1561, 1563, 1565, 1567, 1569, 1571, 1573, 1575, 1577, 1579, 1581, 1583, 1585, 1587, 1589, 1591, 1593, 1595, 1597, 1599, 1601, 1603, 1605, 1607, 1609, 1611, 1613, 1615, 1617, 1619, 1621, 1623, 1625, 1627, 1629, 1631, 1633, 1635, 1637, 1639, 1641, 1643, 1645, 1647, 1649, 1651, 1653, 1655, 1657, 1659, 1661, 1663, 1665, 1667, 1669, 1671, 1673, 1675, 1677, 1679, 1681, 1683, 1685, 1687, 1689, 1691, 1693, 1695, 1697, 1699, 1701, 1703, 1705, 1707, 1709, 1711, 1713, 1715, 1717, 1719, 1721, 1723, 1725, 1727, 1729, 1731, 1733, 1735, 1737, 1739, 1741, 1743, 1745, 1747, 1749, 1751, 1753, 1755, 1757, 1759, 1761, 1763, 1765, 1767, 1769, 1771, 1773, 1775, 1777, 1779, 1781, 1783, 1785, 1787, 1789, 1791, 1793, 1795, 1797, 1799, 1801, 1803, 1805, 1807, 1809, 1811, 1813, 1815, 1817, 1819, 1821, 1823, 1825, 1827, 1829, 1831, 1833, 1835, 1837, 1839, 1841, 1843, 1845, 1847, 1849, 1851, 1853, 1855, 1857, 1859, 1861, 1863, 1865, 1867, 1869, 1871, 1873, 1875, 1877, 1879, 1881, 1883, 1885, 1887, 1889, 1891, 1893, 1895, 1897, 1899, 1901, 1903, 1905, 1907, 1909, 1911, 1913, 1915, 1917, 1919, 1921, 1923, 1925, 1927, 1929, 1931, 1933, 1935, 1937, 1939, 1941, 1943, 1945, 1947, 1949, 1951, 1953, 1955, 1957, 1959, 1961, 1963, 1965, 1967, 1969, 1971, 1973, 1975, 1977, 1979, 1981, 1983, 1985, 1987, 1989, 1991, 1993, 1995, 1997, 1999, 2001, 2003, 2005, 2007, 2009, 2011, 2013, 2015, 2017, 2019, 2021, 2023, 2025, 2027, 2029, 2031, 2033, 2035, 2037, 2039, 2041, 2043, 2045, 2047, 2049, 2051, 2053, 2055, 2057, 2059, 2061, 2063, 2065, 2067, 2069, 2071, 2073, 2075, 2077, 2079, 2081, 2083, 2085, 2087, 2089, 2091, 2093, 2095, 2097, 2099, 2101, 2103, 2105, 2107, 2109, 2111, 2113, 2115, 2117, 2119, 2121, 2123, 2125, 2127, 2129, 2131, 2133, 2135, 2137, 2139, 2141, 2143, 2145, 2147, 2149, 2151, 2153, 2155, 2157, 2159, 2161, 2163, 2165, 2167, 2169, 2171, 2173, 2175, 2177, 2179, 2181, 2183, 2185, 2187, 2189, 2191, 2193, 2195, 2197, 2199, 2201, 2203, 2205, 2207, 2209, 2211, 2213, 2215, 2217, 2219, 2221, 2223, 2225, 2227, 2229, 2231, 2233, 2235, 2237, 2239, 2241, 2243, 2245, 2247, 2249, 2251, 2253, 2255, 2257, 2259, 2261, 2263, 2265, 2267, 2269, 2271, 2273, 2275, 2277, 2279, 2281, 2283, 2285, 2287, 2289, 2291, 2293, 2295, 2297, 2299, 2301, 2303, 2305, 2307, 2309, 2311, 2313, 2315, 2317, 2319, 2321, 2323, 2325, 2327, 2329, 2331, 2333, 2335, 2337, 2339, 2341, 2343, 2345, 2347, 2349, 2351, 2353, 2355, 2357, 2359, 2361, 2363, 2365, 2367, 2369, 2371, 2373, 2375, 2377, 2379, 2381, 2383, 2385, 2387, 2389, 2391, 2393, 2395, 2397, 2399, 2401, 2403, 2405, 2407, 2409, 2411, 2413, 2415, 2417, 2419, 2421, 2423, 2425, 2427, 2429, 2431, 2433, 2435, 2437, 2439, 2441, 2443, 2445, 2447, 2449, 2451, 2453, 2455, 2457, 2459, 2461, 2463, 2465, 2467, 2469, 2471, 2473, 2475, 2477, 2479, 2481, 2483, 2485, 2487, 2489, 2491, 2493, 2495, 2497, 2499, 2501, 2503, 2505, 2507, 2509, 2511, 2513, 2515, 2517, 2519, 2521, 2523, 2525, 2527, 2529, 2531, 2533, 2535, 2537, 2539, 2541, 2543, 2545, 2547, 2549, 2551, 2553, 2555, 2557, 2559, 2561, 2563, 2565, 2567, 2569, 2571, 2573, 2575, 2577, 2579, 2581, 2583, 2585, 2587, 2589, 2591, 2593, 2595, 2597, 2599, 2601, 2603, 2605, 2607, 2609, 2611, 2613, 2615, 2617, 2619, 2621, 2623, 2625, 2627, 2629, 2631, 2633, 2635, 2637, 2639, 2641, 2643, 2645, 2647, 2649, 2651, 2653, 2655, 2657, 2659, 2661, 2663, 2665, 2667, 2669, 2671, 2673, 2675, 2677, 2679, 2681, 2683, 2685, 2687, 2689, 2691, 2693, 2695, 2697, 2699, 2701, 2703, 2705, 2707, 2709, 2711, 2713, 2715, 2717, 2719, 2721, 2723, 2725, 2727, 2729, 2731, 2733, 2735, 2737, 2739, 2741, 2743, 2745, 2747, 2749, 2751, 2753, 2755, 2757, 2759, 2761, 2763, 2765, 2767, 2769, 2771, 2773, 2775, 2777, 2779, 2781, 2783, 2785, 2787, 2789, 2791, 2793, 2795, 2797, 2799, 2801, 2803, 2805, 2807, 2809, 2811, 2813, 2815, 2817, 2819, 2821, 2823, 2825, 2827, 2829, 2831, 2833, 2835, 2837, 2839, 2841, 2843, 2845, 2847, 2849, 2851, 2853, 2855, 2857, 2859, 2861, 2863, 2865, 2867, 2869, 2871, 2873, 2875, 2877, 2879, 2881, 2883, 2885, 2887, 2889, 2891, 2893, 2895, 2897, 2899, 2901, 2903, 2905, 2907, 2909, 2911, 2913, 2915, 2917, 2919, 2921, 2923, 2925, 2927, 2929, 2931, 2933, 2935, 2937, 2939, 2941, 2943, 2945, 2947, 2949, 2951, 2953, 2955, 2957, 2959, 2961, 2963, 2965, 2967, 2969, 2971, 2973, 2975, 2977, 2979, 2981, 2983, 2985, 2987, 2989, 2991, 2993, 2995, 2997, 2999, 3001, 3003, 3005, 3007, 3009, 3011, 3013, 3015, 3017, 3019, 3021, 3023, 3025, 3027, 3029, 3031, 3033, 3035, 3037, 3039, 3041, 3043, 3045, 3047, 3049, 3051, 3053, 3055, 3057, 3059, 3061, 3063, 3065, 3067, 3069, 3071, 3073, 3075, 3077, 3079, 3081, 3083, 3085, 3087, 3089, 3091, 3093, 3095, 3097, 3099, 3101, 3103, 3105, 3107, 3109, 3111, 3113, 3115, 3117, 3119, 3121, 3123, 3125, 3127, 3129, 3131, 3133, 3135, 3137, 3139, 3141, 3143, 3145, 3147, 3149, 3151, 3153, 3155, 3157, 3159, 3161, 3163, 3165, 3167, 3169, 3171, 3173, 3175, 3177, 3179, 3181, 3183, 3185, 3187, 3189, 3191, 3193, 3195, 3197, 3199, 3201, 3203, 3205, 3207, 3209, 3211, 3213, 3215, 3217, 3219, 3221, 3223, 3225, 3227, 3229, 3231, 3233, 3235, 3237, 3239, 3241, 3243, 3245, 3247, 3249, 3251, 3253, 3255, 3257, 3259, 3261, 3263, 3265, 3267, 3269, 3271, 3273, 3275, 3277, 3279, 3281, 3283, 3285, 3287, 3289, 3291, 3293, 3295, 3297, 3299, 3301, 3303, 3305, 3307, 3309, 3311, 3313, 3315, 3317, 3319, 3321, 3323, 3325, 3327, 3329, 3331, 3333, 3335, 3337, 3339, 3341, 3343, 3345, 3347, 3349, 3351, 3353, 3355, 3357, 3359, 3361, 3363, 3365, 3367, 3369, 3371, 3373, 3375, 3377, 3379, 3381, 3383, 3385, 3387, 3389, 3391, 3393, 3395, 3397, 3399, 3401, 3403, 3405, 3407, 3409, 3411, 3413, 3415, 3417, 3419, 3421, 3423, 3425, 3427, 3429, 3431, 3433, 3435, 3437, 3439, 3441, 3443, 3445, 3447, 3449, 3451, 3453, 3455, 3457, 3459, 3461, 3463, 3465, 3467, 3469, 3471, 3473, 3475, 3477, 3479, 3481, 3483, 3485, 3487, 3489, 3491, 3493, 3495, 3497, 3499, 3501, 3503, 3505, 3507, 3509, 3511, 3513, 3515, 3517, 3519, 3521, 3523, 3525, 3527, 3529, 3531, 3533, 3535, 3537, 3539, 3541, 3543, 3545, 3547, 3549, 3551, 3553, 3555, 3557, 3559, 3561, 3563, 3565, 3567, 3569, 3571, 3573, 3575, 3577, 3579, 3581, 3583, 3585, 3587, 3589, 3591, 3593, 3595, 3597, 3599, 3601, 3603, 3605, 3607, 3609, 3611, 3613, 3615, 3617, 3619, 3621, 3623, 3625, 3627, 3629, 3631, 3633, 3635, 3637, 3639, 3641, 3643, 3645, 3647, 3649, 3651, 3653, 3655, 3657, 3659, 3661, 3663, 3665, 3667, 3669, 3671, 3673, 3675, 3677, 3679, 3681, 3683, 3685, 3687, 3689, 3691, 3693, 3695, 3697, 3699, 3701, 3703, 3705, 3707, 3709, 3711, 3713, 3715, 3717, 3719, 3721, 3723, 3725, 3727, 3729, 3731, 3733, 3735, 3737, 3739, 3741, 3743, 3745, 3747, 3749, 3751, 3753, 3755, 3757, 3759, 3761, 3763, 3765, 3767, 3769, 3771, 3773, 3775, 3777, 3779, 3781, 3783, 3785, 3787, 3789, 3791, 3793, 3795, 3797, 3799, 3801, 3803, 3805, 3807, 3809, 3811, 3813, 3815, 3817, 3819, 3821, 3823, 3825, 3827, 3829, 3831, 3833, 3835, 3837, 3839, 3841, 3843, 3845, 3847, 3849, 3851, 3853, 3855, 3857, 3859, 3861, 3863, 3865, 3867, 3869, 3871, 3873, 3875, 3877, 3879, 3881, 3883, 3885, 3887, 3889, 3891, 3893, 3895, 3897, 3899, 3901, 3903, 3905, 3907, 3909, 3911, 3913, 3915, 3917, 3919, 3921, 3923, 3925, 3927, 3929, 3931, 3933, 3935, 3937, 3939, 3941, 3943, 3945, 3947, 3949, 3951, 3953, 3955, 3957, 3959, 3961, 3963, 3965, 3967, 3969, 3971, 3973, 3975, 3977, 3979, 3981, 3983, 3985, 3987, 3989, 3991, 3993, 3995, 3997, 3999, 4001, 4003, 4005, 4007, 4009, 4011, 4013, 4015, 4017, 4019, 4021, 4023, 4025, 4027, 4029, 4031, 4033, 4035, 4037, 4039, 4041, 4043, 4045, 4047, 4049, 4051, 40

ISSUED FOR CONSTRUCTION
 A.I. NO. AI-MC-0073
 5 JAN 2021

- LEGEND:**
- PRECAST FACADE
 - MAX 500mm SURVIVAL SLAT
 - CONTINUOUS ACCESS ROUES FOR MAINTENANCE UNDER RFP-93
 - * AB * ACOUSTIC BALCONY
 - * AD * ACOUSTIC DOOR (SHUFFLE TYPE)
 - * AW * ACOUSTIC WINDOW
 - * M * FLYS CLASING / FLYES GLAZING WITH MAINTENANCE FOR U.P. DOOR
 - * SC * WITH SELF-CLOSING MECHANISM FOR U.P. DOOR
 - * O.A. * WINDOW OPENABLE AREA
 - * A.F. * ARCHITECTURAL FEATURE

Arace Cheung
 Cheung Yee Ying Grace
 for and on behalf of
 AGC Design Ltd
 Authorized Person
 (List of Architects)

BD AMENDED PLAN 14 AUG 2020

A	30 RE-SLOW DOWN	HWK 02 2019 CC
B	MAJOR AMENDMENT	HWK 03 2019 CC
C	MAJOR AMENDMENT	HWK 11 2019 CC
D	MAJOR AMENDMENT	HWK 13 2019 CC
E	MAJOR AMENDMENT	HWK 15 2019 CC
F	MAJOR AMENDMENT	HWK 20 2019 CC
G	AMENDMENT	DW 105 2019 CC
H	AMENDMENT	DW 07 2019 CC
J	AMENDMENT	AC 10 2019 CC
K	AMENDMENT	AC 12 2019 CC
L	AMENDMENT	AC 08 2020 CC

AGC DESIGN LTD

AGC DESIGN LTD
 11/F, 110 HONG KONG STREET, HONG KONG
 香港 德輔道中 110 號 11 樓 AGC DESIGN LTD

PROPOSED RESIDENTIAL DEVELOPMENT
 AT 139-147 ARCADE STREET,
 KOWLOON INLAND LOT Nos. 6005,
 6035 R.P., 6036 R.P., 6037 R.P.
 & 6038 R.P.

22th FLOOR PLAN
 (SHEET 2)

Plan Approver

 NG Mei-oh
 Senior Building Surveyor
 6-31 BUILDING AUTHORITY
 11 SEP 2020

*THE WORKS SHOWN ON THESE PLANS ARE TYPE II WORKS (GENERAL BUILDING WORKS) IN RESPECT OF WHICH (COUSEN) IS APPLIED FOR THE PURPOSE OF FAST TRACK CONSENT APPLICATION UNDER REGULATION 33 OF THE BUILDING (GENERAL BUILDING WORKS) REGULATIONS

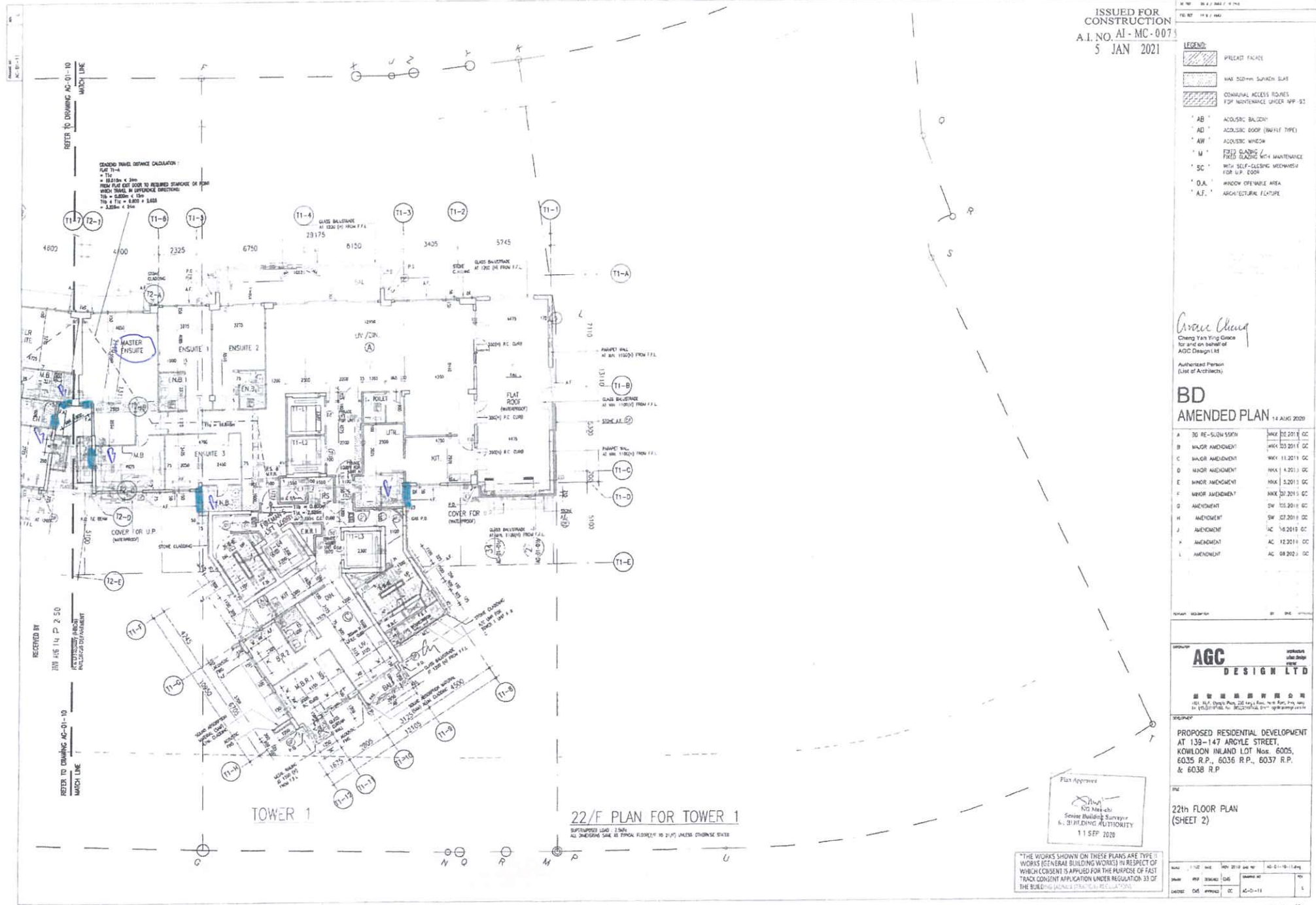

TOWER 1

22/F PLAN FOR TOWER 1

SUPPLEMENTED UNDER SECTION 15(1) OF THE BUILDING (GENERAL BUILDING WORKS) REGULATIONS

RECEIVED BY
 270 AVE 14 P 2 50
 REVISIONS/REVISIONS
 REFER TO DRAWING AC-01-10 MARCH LINE

REFER TO DRAWING AC-01-10 MARCH LINE

DOOR PANEL ORNAMENT CALCULATION:
 Flat Top
 = 0.825m x 3m
 FROM FLAT TOP DOOR TO RECESSED STAIRCASE OR FROM
 WHICH PANEL IS APPLICABLE DEPENDS
 Top = 0.825m x 1.5m
 Top = 1.2375m x 1.5m
 = 1.85625m x 3m



MATCH LINE
 REFER TO DRAWING AG-01-13

LEGEND
 PRECAST FACED
 MAX. 500mm STAIRWAY SLAB
 COMMON ACCESS ROUTES FOR MAINTENANCE (REFER APP-93)

- AB ACOUSTIC BALCONY
- AD ACOUSTIC DOOR (BATTLE TYPE)
- AW ACOUSTIC WINDOW
- M FIXED GLAZING WITH MAINTENANCE
- SC WITH SELF-CLOSING MECHANISM FOR L.I.P. DOOR
- O.A. WINDOW OPERABLE AREA
- A.F. ARCHITECTURAL FEATURE

REAR WALL DISTANCE CALC. RUC TR-A
 = 111
 FROM RUC DIST. TO RUC TO RUC WHICH WALL IS REFERRED DIST. TR-B
 = 12000
 TR-C = 12000
 TR-D = 12000
 TR-E = 12000
 TR-F = 12000
 TR-G = 12000
 TR-H = 12000
 TR-I = 12000
 TR-J = 12000
 TR-K = 12000
 TR-L = 12000
 TR-M = 12000

ISSUED FOR CONSTRUCTION
 A.I. NO. AI-MC-0098
 25 MAR 2021
Grace Cheng
 Grace Cheng
 Chartered Professional Engineer
 (Structural) (P.Eng.)
 (Professional Seal No. 12345)

AMENDED PLAN FEB 2021

A	RE-SUBMISSION	10/02/2021	CC
B	MAJOR AMENDMENT	11/02/2021	CC
C	MAJOR AMENDMENT	11/02/2021	CC
D	MINOR AMENDMENT	11/02/2021	CC
E	MINOR AMENDMENT	11/02/2021	CC
F	MINOR AMENDMENT	11/02/2021	CC
G	AMENDMENT	11/02/2021	CC
H	AMENDMENT	11/02/2021	CC
I	AMENDMENT	11/02/2021	CC
J	AMENDMENT	11/02/2021	CC
K	AMENDMENT	11/02/2021	CC
L	AMENDMENT	11/02/2021	CC
M	AMENDMENT	11/02/2021	CC

MATCH LINE
 REFER TO DRAWING AG-01-13

AGC DESIGN LTD
 香港建築師學會
 111, Des Voeux Road, 22/F, Prince's Building, Hong Kong
 Tel: (852) 2522 1234 Fax: (852) 2522 1234 Email: info@agc.com.hk

PROPOSED RESIDENTIAL DEVELOPMENT
 AT 139-147 ARCYLE STREET,
 KOWLOON INLAND LOT Nos. 6005,
 6035 R.P., 6036 R.P., 6037 R.P.
 & 6038 R.P.

Plan Approved
 NG Macphail
 Senior Building Surveyor
 for BUILDING AUTHORITY
 11 MAR 2021

23th FLOOR PLAN
 (SHEET 1)

THE WORKS SHOWN ON THESE PLANS ARE TYPE II WORKS (GENERAL BUILDING WORKS) FOR PHASE A1, A2 IN ZONE A AND PHASE C (PORTION A, B, C, D, E, F, G, H, I, J, K, L, M, N, O, P, Q, R, S, T, U, V, W, X, Y, Z) BY RESPECT OF WHICH CONSENT IS APPLIED FOR THE PURPOSE OF FAST TRACK CONSENT APPLICATION UNDER REGULATION 33 OF THE BUILDING (ADMINISTRATION) REGULATIONS.

DATE: 11/03/2021
 TIME: 10:00 AM
 DRAWN BY: NG Macphail
 CHECKED BY: NG Macphail
 SCALE: AS SHOWN
 PROJECT NO.: AG-01-13-1300

TOWER 3
 TOWER 2
23th FLOOR PLAN FOR TOWER 2 & TOWER 3
 SUPERSEDED LOG 1346

ISSUED FOR CONSTRUCTION
 A.I. NO. AJ-MC-007
 5 JAN 2021

- LEGEND:**
- BREAKFAST FACILITY
 - MAX. SLOPE SURFACES SLAB
 - COMMONAL ACCESS ROUTES FOR MAINTENANCE UNDER RFP-3.2
 - AB ACoustic BALCONY
 - AD ACoustic DOOR (BATTLER TYPE)
 - AW ACoustic WINDOW
 - M FIXED GLAZING / FIXED GLAZING WITH MAINTENANCE
 - SC WITH SELF-CLOSING MECHANISM FOR A.P. DOOR
 - OA WINDOW OPENABLE AREA
 - A.F. ARCHITECTURAL FEATURE

Chang Yung
 Chang Yung Group
 for and on behalf of
 AGC Design Ltd
 Authorized Person
 (List of Architects)

BD AMENDED PLAN 14 AUG 2020

A	30 RE-SUBMISSION	19/08/2011	CC
B	MAJOR AMENDMENT	19/03/2011	CC
C	MAJOR AMENDMENT	19/11/2011	CC
D	MINOR AMENDMENT	19/04/2011	CC
E	MINOR AMENDMENT	19/03/13	CC
F	MINOR AMENDMENT	17/2015	CC
G	AMENDMENT	04/05/2018	CC
H	AMENDMENT	15/07/2018	CC
J	AMENDMENT	16/2019	CC
K	AMENDMENT	12/2019	CC
L	AMENDMENT	14/2020	CC

AGC DESIGN LTD

AGC DESIGN LTD
 227, Argyle Street, 22/F, Kowloon, Hong Kong
 Tel: 2322 8718 Fax: 2322 8717 Email: agc@agc.com.hk

PROPOSED RESIDENTIAL DEVELOPMENT
 AT 139-147 ARGYLE STREET,
 KOWLOON INLAND LOT Nos. 6005,
 6035 R.P., 6036 R.P., 6037 R.P.
 & 6038 R.P.

23th FLOOR PLAN
 (SHEET 2)

Paul Appleton

 Senior Building Surveyor
 THE BUILDING AUTHORITY
 11 SEP 2020

"THE WORKS SHOWN ON THESE P-ANS ARE TYPE II WORKS (GENERAL BUILDING WORKS) IN RESPECT OF WHICH CONSENT IS APPLIED FOR THE PURSUE OF FAST-TRACK CONSENT APPLICATION UNDER REGULATION 33 OF THE BUILDING (ADMINISTRATION) REGULATIONS"

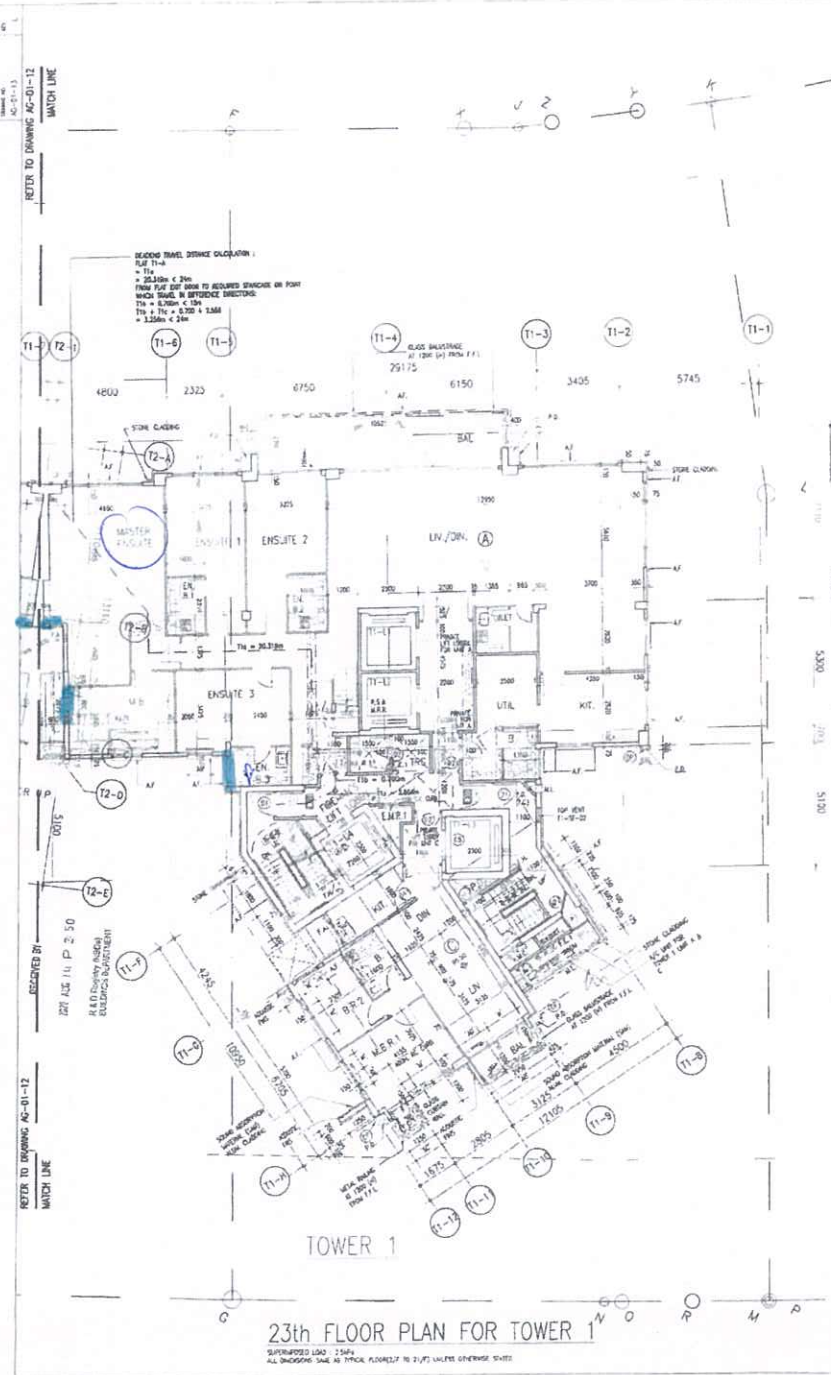

23th FLOOR PLAN FOR TOWER 1
 SUPERIMPOSED LOAD: 2.5kPa
 ALL DIMENSIONS SHOWN AS PER PLAN UNLESS OTHERWISE STATED

SCALE	1:100	DATE	11/09/2020	PROJECT NO.	AG-01-13-13-004
DRAWN BY	AGC	CHECKED BY	AGC	DATE	11/09/2020
REVISION	001	APPROVED BY	AGC	DATE	11/09/2020