

工程指示 / 要求簡箋(E.I.)

工程指示編號：EI / 3053 / 21 修改版次：A
 工程編號：J - 852 工程名稱：亞皆老街中電
 工程項目：欄河 地盤用 鋁料 (T1-T3) (1-23/F, R/F) *(減去 T1-T3: 3-6/F)*
 收件人：生統 發件人：Ant Yeung 日期：23/02/2021

要求提供 / 確認 事項：

- | | | |
|------------------------------------|-------------------------------------|-------------------------------|
| <input type="checkbox"/> 初步鋁料 B.M. | <input type="checkbox"/> 加工拆圖，然後生產 | <input type="checkbox"/> 尺寸表 |
| <input type="checkbox"/> 正式鋁料 B.M. | <input type="checkbox"/> 技術上資料 / 指示 | <input type="checkbox"/> 報價 |
| <input type="checkbox"/> 配件 B.M. | <input type="checkbox"/> 樣辦或貨品說明書 | <input type="checkbox"/> 分判合約 |

內容：

A 版：已修改加工圖。附上 M01-M04 開料單。所有有色料色號：UCT806812X2-3。

請按加工圖生產鋁料供地盤用。(T1-T3)大貨 (不包括 T1-T3: 3-6/F) Metal Rail/ Glass Bal

包扎：1 個露台 1 扎。 *T3 優先出貨

請在 2021.03.02 前完成上列要求。

附：9 頁加工圖+ 61 頁開料單

以上項目為：

- 原合約工程包 原合約工程加 / 減賬 新工程報價

原因：-

分發東莞各部門：

- | | | | | | | | |
|---------------------------------|------------------------------|---|------------------------------|--|------------------------------|--------------------------------|------------------------------|
| <input type="checkbox"/> 生產技術總監 | <input type="checkbox"/> 連附件 | <input type="checkbox"/> 技術部 | <input type="checkbox"/> 連附件 | <input type="checkbox"/> 生產部 | <input type="checkbox"/> 連附件 | <input type="checkbox"/> 機械設計部 | <input type="checkbox"/> 連附件 |
| <input type="checkbox"/> 採購部 | <input type="checkbox"/> 連附件 | <input checked="" type="checkbox"/> 生產統籌部 | <input type="checkbox"/> 連附件 | <input checked="" type="checkbox"/> 小羅&清 | <input type="checkbox"/> 連附件 | | |
| <input type="checkbox"/> 質檢部 | <input type="checkbox"/> 連附件 | <input type="checkbox"/> 會計部 | <input type="checkbox"/> 連附件 | <input type="checkbox"/> 報關組 | <input type="checkbox"/> 連附件 | <input type="checkbox"/> 其他 | <input type="checkbox"/> 連附件 |

分發其他分判：

- 水洪 連附件

分發香港各部門：

- | | | | | | | | | |
|------------------------------|------------------------------|-------------------------------|------------------------------|------------------------------|------------------------------|----------------------------------|------------------------------|----|
| <input type="checkbox"/> 行政部 | <input type="checkbox"/> 連附件 | <input type="checkbox"/> 會計部 | <input type="checkbox"/> 連附件 | <input type="checkbox"/> 統籌部 | <input type="checkbox"/> 連附件 | <input type="checkbox"/> 工程部地盤科文 | <input type="checkbox"/> 連附件 | 祥哥 |
| <input type="checkbox"/> 採購部 | <input type="checkbox"/> 連附件 | <input type="checkbox"/> QS 部 | <input type="checkbox"/> 連附件 | <input type="checkbox"/> 維修部 | <input type="checkbox"/> 連附件 | <input type="checkbox"/> 其他 | <input type="checkbox"/> 連附件 | |

傳遞編號：

HK 341 / 21

發件人簽署：

項目經理簽署：



美特鋁質有限公司

MIDI Aluminium Fabricator Ltd.

工程號

J-852

地盤

亞皆老街/擱河

序號	物料編號	數量	使用位置	樓層
1	51-MS01-LTR02-A6(頂)	1	SD-GB-5001	T1/(1F)
2	51-MS01-LTR02-A6(頂)	1	SD-GB-5001	T2/(1F)
3	51A-MS01-LTR02-A6(頂)	1	SD-GB-5001A	T3/(1F)
4	51B-MS01-LTR02-A6(頂)	16	SD-GB-5001B	T1/(2F~23F)
5	51B-MS01-LTR02-A6(頂)	16	SD-GB-5001B	T2/(2F~23F)
6	51B-MS01-LTR02-A6(頂)	16	SD-GB-5001B	T3/(2F~23F)

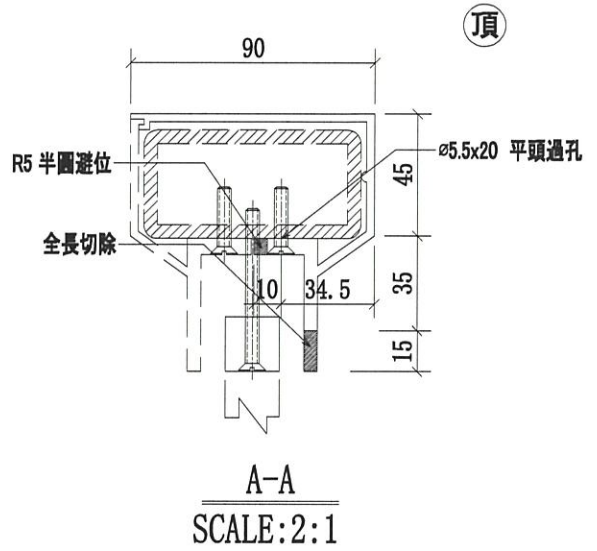
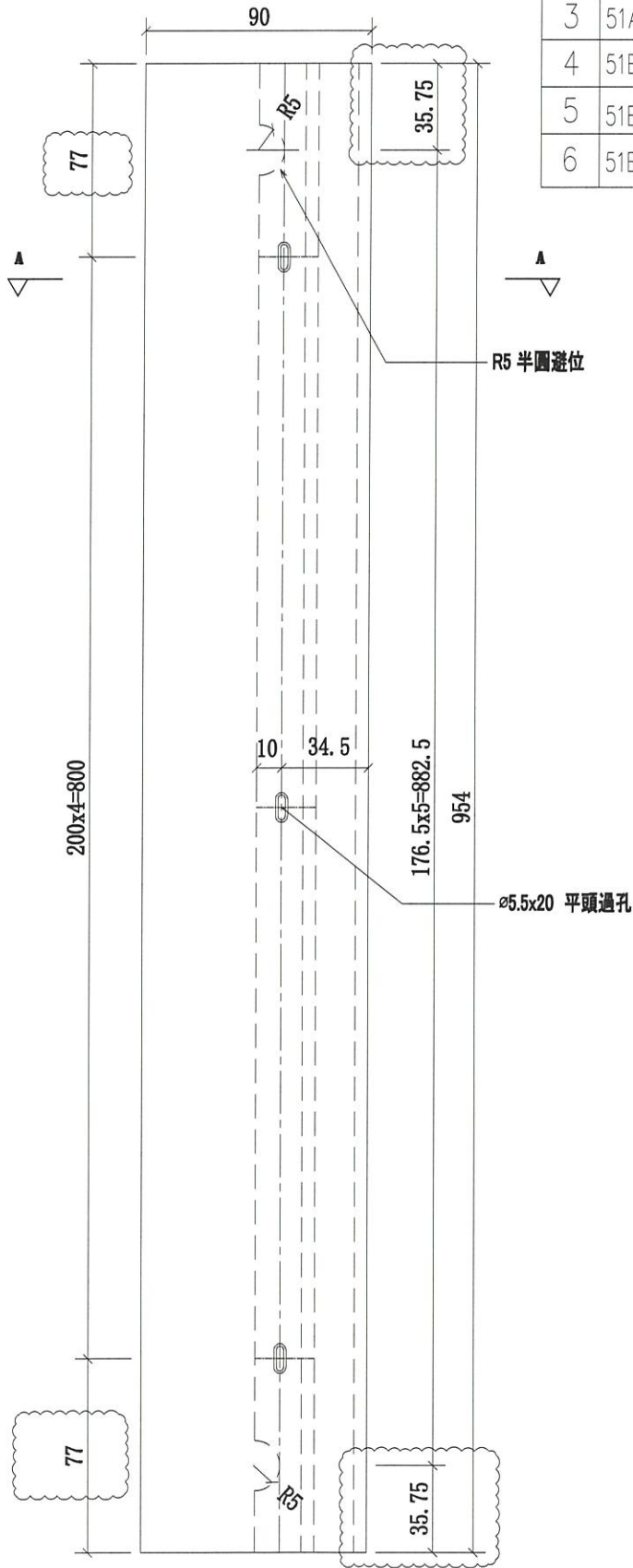

名稱	擱河鋁橫梁	制圖	CJM	2021.1.15	修改	A	
材料	X85900(A6)	復核	-	-	日期	2021.02.22	
顏色	PVF2 3-COATING FINISH	批準			圖號	51B-MS01-LTR02-A6(頂)	



美特鋁質有限公司
MIDI Aluminium Fabricator Ltd.

工程號: J-852 | 地盤: 亞皆老街/擱河

序號	物料編號	數量	使用位置	樓層
1	51-MS01-LTR02-A7(頂)	1	SD-GB-5001	T1/(1F)
2	51-MS01-LTR02-A7(頂)	1	SD-GB-5001	T2/(1F)
3	51A-MS01-LTR02-A7(頂)	1	SD-GB-5001A	T3/(1F)
4	51B-MS01-LTR02-A7(頂)	16	SD-GB-5001B	T1/(2F~23F)
5	51B-MS01-LTR02-A7(頂)	16	SD-GB-5001B	T2/(2F~23F)
6	51B-MS01-LTR02-A7(頂)	16	SD-GB-5001B	T3/(2F~23F)

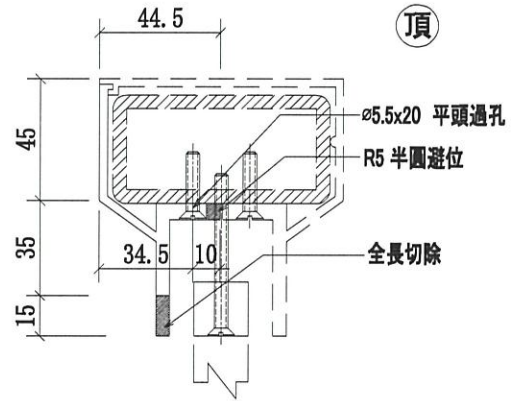
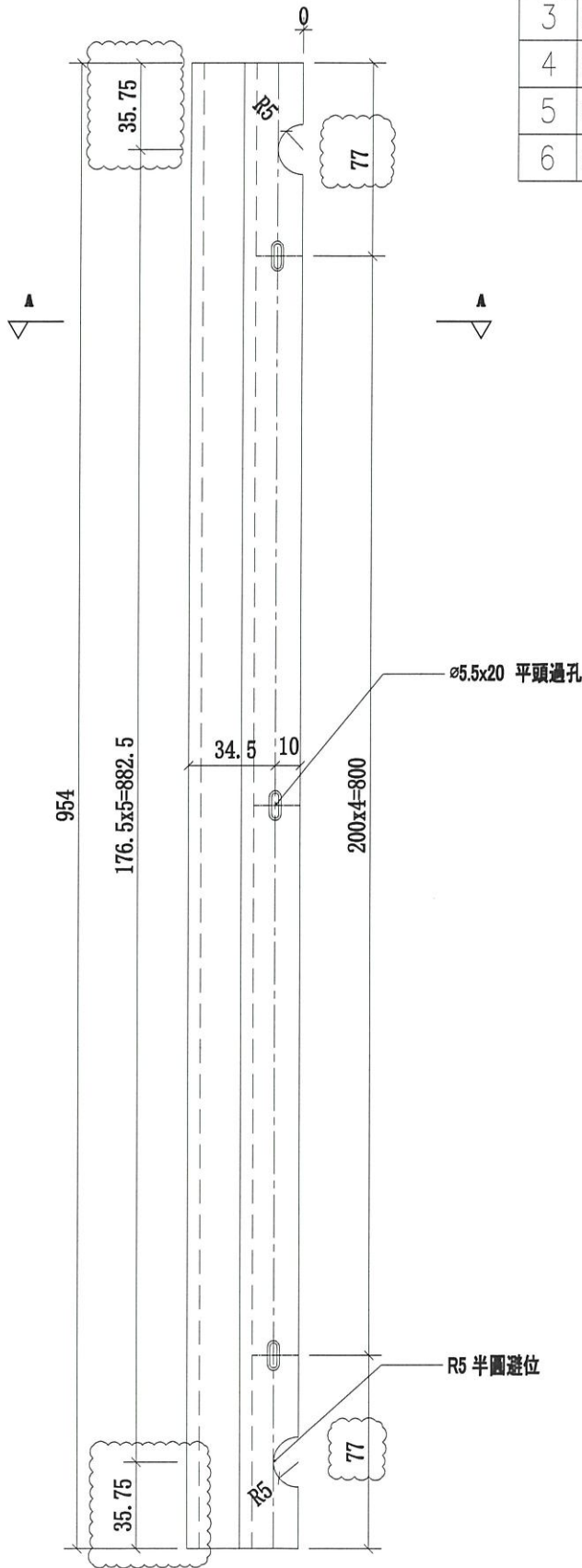

A-A
SCALE: 2:1

名稱	擱河鋁橫梁	制圖	CJM	2021.1.15	修改	A	
材料	X85901(A7)	復核	-	-	日期	2021.02.22	
顏色	PVF2 3-COATING FINISH	批准			圖號	51B-MS01-LTR02-A7(頂)	



美特鋁質有限公司
MIDI Aluminium Fabricator Ltd.

工程號 J-852 地盤 亞皆老街/攔河

序號	物料編號	數量	使用位置	樓層
1	51-MS01-LTR05-A7(底)	1	SD-GB-5001	T1/(1F)
2	51-MS01-LTR05-A7(底)	1	SD-GB-5001	T2/(1F)
3	51A-MS01-LTR05-A7(底)	1	SD-GB-5001A	T3/(1F)
4	51B-MS01-LTR05-A7(底)	16	SD-GB-5001B	T1/(2F~23F)
5	51B-MS01-LTR05-A7(底)	16	SD-GB-5001B	T2/(2F~23F)
6	51B-MS01-LTR05-A7(底)	16	SD-GB-5001B	T3/(2F~23F)

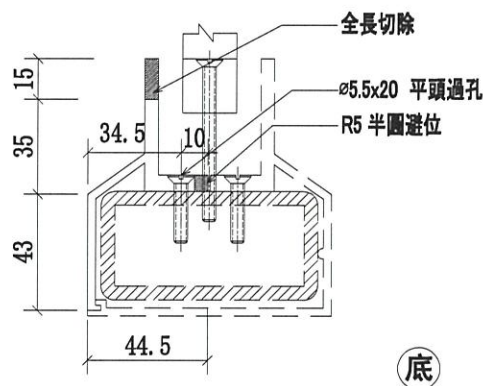
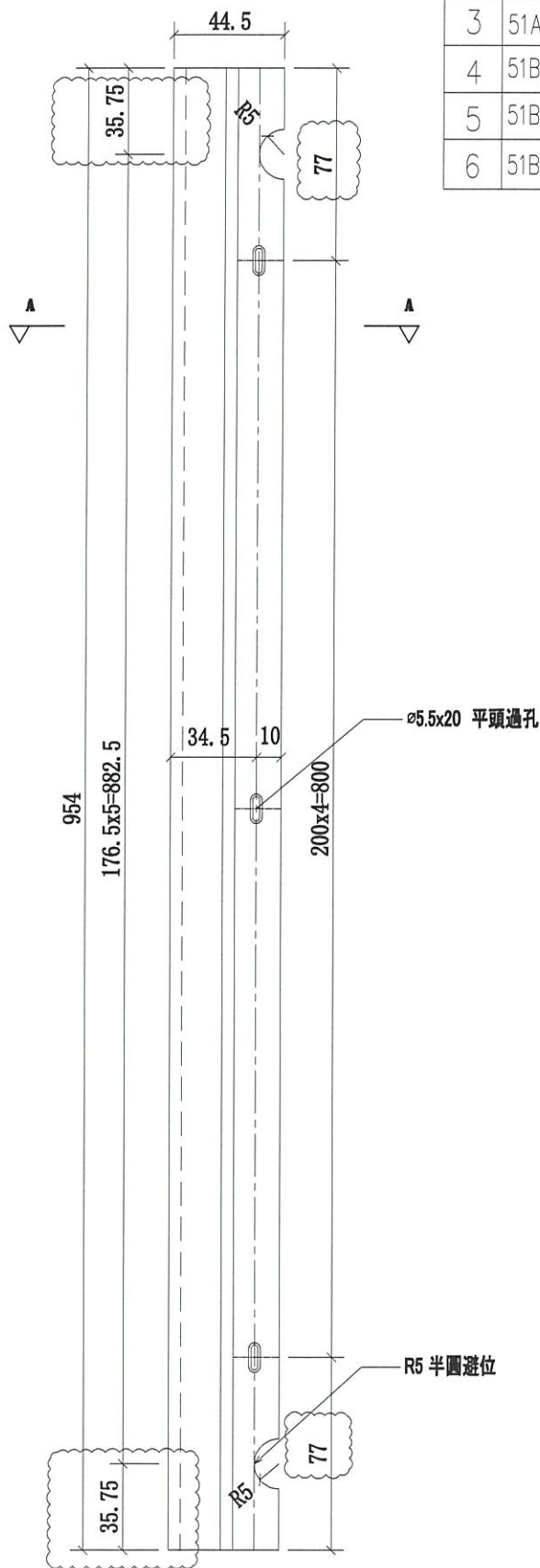

A-A
SCALE: 2:1

名稱	攔河鋁橫梁	制圖	CJM	2021.1.15	修改	A	
材料	X85901(A7)	復核	-	-	日期	2021.02.22	
顏色	PVF2 3-COATING FINISH	批准			圖號	51B-MS01-LTR05-A7(底)	



美特鋁質有限公司

MIDI Aluminium Fabricator Ltd.

工程號

J-852

地盤

亞皆老街/攔河

序號	物料編號	數量	使用位置	樓層
1	51-MS01-LTR05-A8(底)	1	SD-GB-5001	T1/(1F)
2	51-MS01-LTR05-A8(底)	1	SD-GB-5001	T2/(1F)
3	51A-MS01-LTR05-A8(底)	1	SD-GB-5001A	T3/(1F)
4	51B-MS01-LTR05-A8(底)	16	SD-GB-5001B	T1/(2F~23F)
5	51B-MS01-LTR05-A8(底)	16	SD-GB-5001B	T2/(2F~23F)
6	51B-MS01-LTR05-A8(底)	16	SD-GB-5001B	T3/(2F~23F)

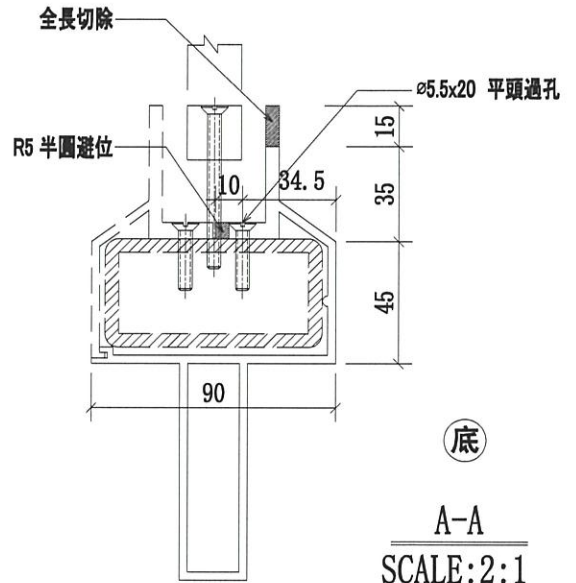
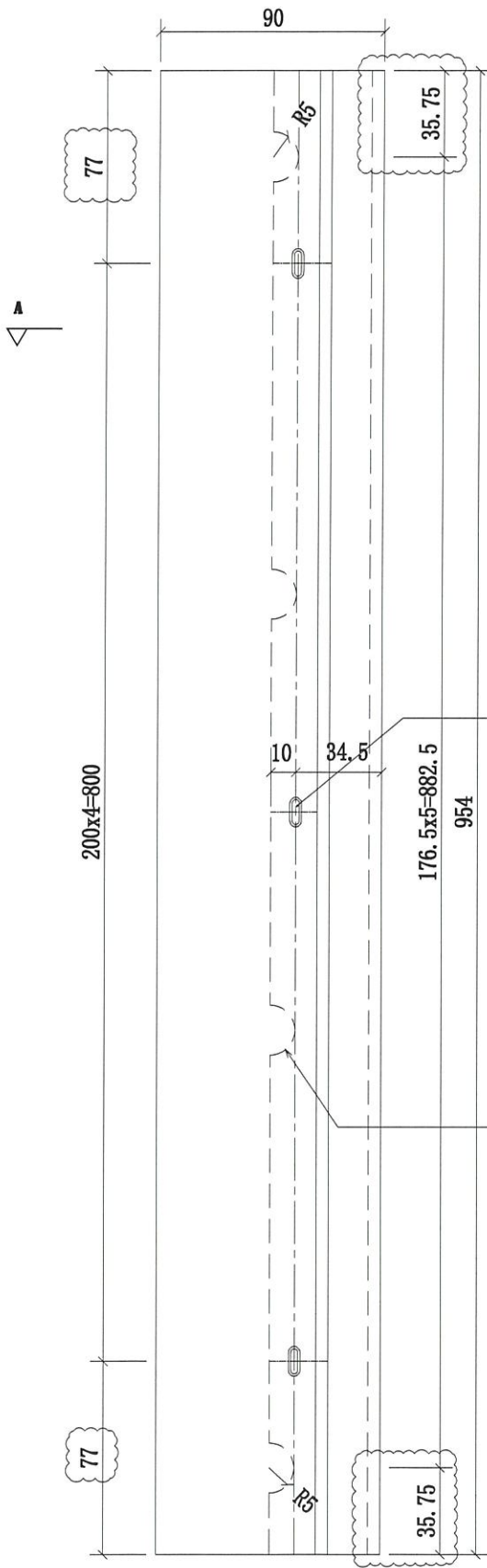

底
A-A
SCALE: 2:1

名稱	攔河鋁橫梁	制圖	CJM	2021.1.15	修改	A	
材料	X85902(A2)	復核	-	-	日期	2021.02.22	
顏色	PVF2 3-COATING FINISH	批准			圖號	51B-MS01-LTR05-A8(底)	



美特鋁質 有限公司

MIDI Aluminium Fabricator Ltd.

工程號

J-852

地盤

亞皆老街/欄河

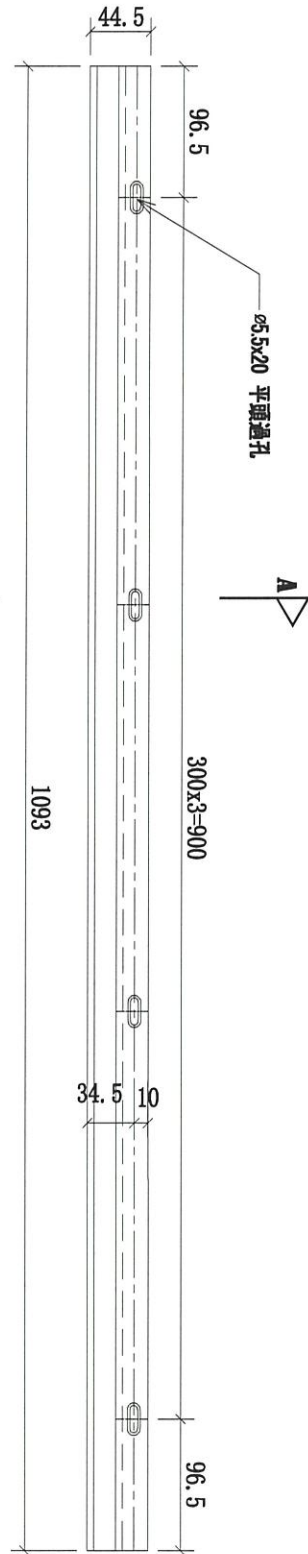

底

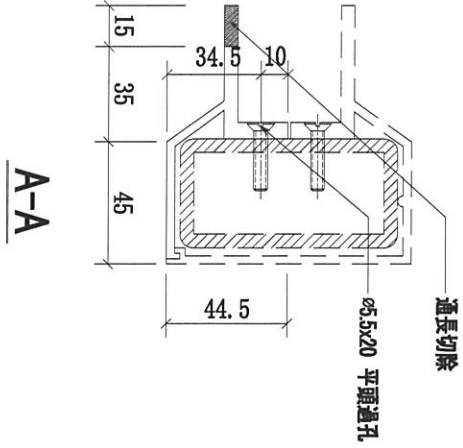

序號	物料編號	數量	L:	A:	M×N:	使用位置	樓層
01	58-MS19-LTR01-A7(底)	1	2384	142	300x7	SD-GB-5008	T1/(22F)
02	58A-MS20+LTR01-A7(底)	1	2384	142	300x7	SD-GB-5008A	T3/(22F)
03	59-MS21+LTR01-A7(底)	1	2384	142	300x7	SD-GB-5009	T3/(22F)
04	59A-MS22+LTR01-A7(底)	1	2384	142	300x7	SD-GB-5009A	T1/(22F)
05	510-MS23+LTR01-A7(底)	1	1218	159	300x3	SD-GB-5010	T1; T2; T3/(ROOF)
06	510-MS23+LTR02-A7(底)	1	1100	100	300x3	SD-GB-5010	T1; T2; T3/(ROOF)
07	510-MS23+LTR03-A7(底)	1	1218	159	300x3	SD-GB-5010	T1; T2; T3/(ROOF)
08	510A-MS24+LTR01-A7(底)	1	1166	133	300x3	SD-GB-5010A	T1; T3/(ROOF)
09	510A-MS24+LTR02-A7(底)	1	429	64.5	300x1	SD-GB-5010A	T1; T3/(ROOF)
10	510A-MS24+LTR03-A7(底)	1	984	42	300x3	SD-GB-5010A	T1; T3/(ROOF)
11	510A-MS24+LTR04-A7(底)	1	429	64.5	300x1	SD-GB-5010A	T1; T3/(ROOF)
12	510A-MS24+LTR05-A7(底)	1	1166	133	300x3	SD-GB-5010A	T1; T3/(ROOF)

名稱	欄河鋁橫梁	制圖	CJM	2021.01.15	修改	A
材料	X85901(A7)	復核	-	-	日期	2020.02.23
顏色	PVF2 3-COATING FINISH	批準			圖號	57-MS10-TR01-A7(底)



美特鋁質有限公司

MIDI Aluminium Fabricator Ltd.

工程號

J-852

地盤

亞皆老街/欄河

底

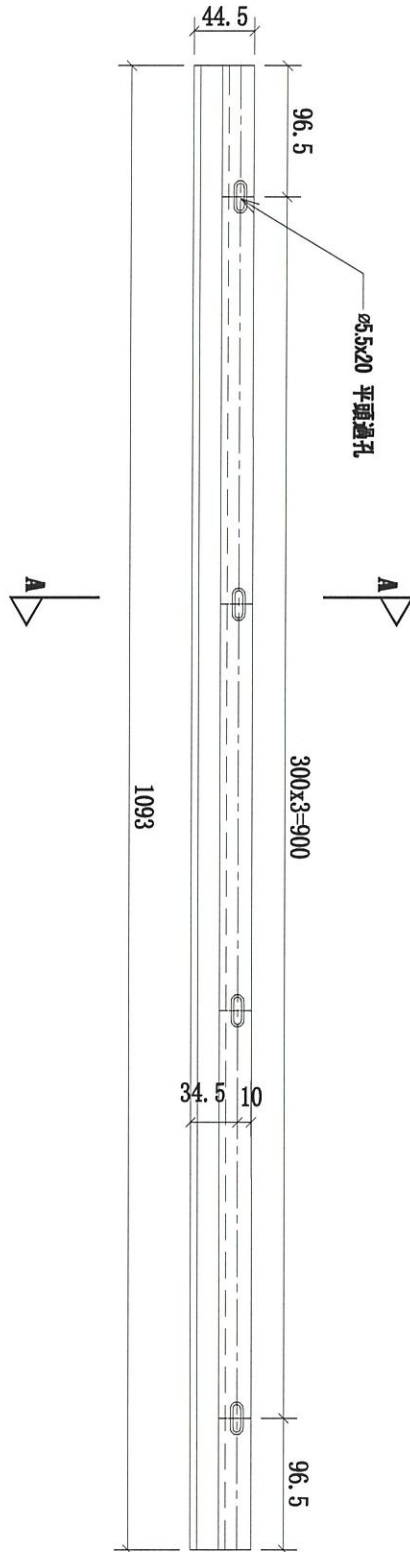
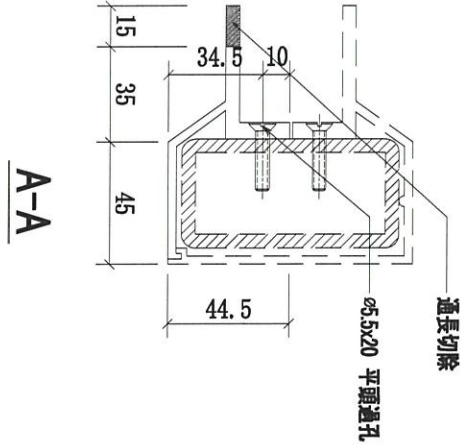

字號	物料編號	數量	L:	A:	M×N:	使用位置	樓層
01	57A-MS10-LTR11-A7(底)	2	1093	96.5	300x3	SD-GB-5007A	T3/(7F~19F)
02	57A-MS10-LTR12-A7(底)	2	1946	73	300x6	SD-GB-5007A	T3/(7F~19F)
03	57A-MS10-LTR13-A7(底)	2	3294	147	300x10	SD-GB-5007A	T3/(7F~19F)
04	57A-MS10-LTR14-A7(底)	2	2146	23	300x7	SD-GB-5007A	T3/(7F~19F)
05	57A-MS10-LTR15-A7(底)	2	1206	153	300x3	SD-GB-5007A	T3/(7F~19F)
06	57A-MS10-LTR16-A7(底)	2	1168	134	300x3	SD-GB-5007	T2/(7F~19F)
07	57A-MS10-LTR17-A7(底)	2	1896	48	300x6	SD-GB-5007	T2/(7F~19F)
08	57-MS10-LTR18-A7(底)	1	3132	66	300x10	SD-GB-5007	T2/(7F~19F)
09	57-MS10-LTR11-A7(底)	2	1093	96.5	300x3	SD-GB-5007B	T1/(7F~19F)
10	57B-MS10-LTR12-A7(底)	2	1946	73	300x6	SD-GB-5007B	T1/(7F~19F)
11	57B-MS10-LTR13-A7(底)	2	3294	147	300x10	SD-GB-5007B	T1/(7F~19F)
12	57B-MS10-LTR14-A7(底)	2	2146	23	300x7	SD-GB-5007B	T1/(7F~19F)
13	57B-MS10-LTR15-A7(底)	2	1206	153	300x3	SD-GB-5007B	T1/(3F~6F)

名稱	欄河鋁橫梁	制圖	CJM	2021.01.15	修改	A
材料	X85901(A7)	復核	-	-	日期	2021.02.16
顏色	PVF2 3-COATING FINISH	批準			圖號	57-MS10-TR04-A7(底)



美特鋁質有限公司

MIDI Aluminium Fabricator Ltd.

工程號

J-852

地盤

亞皆老街/擱河

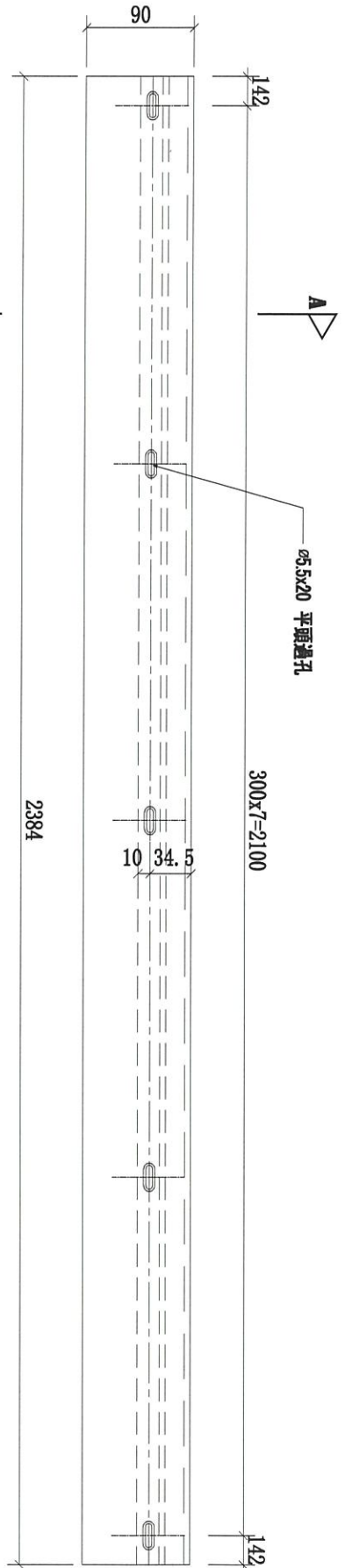
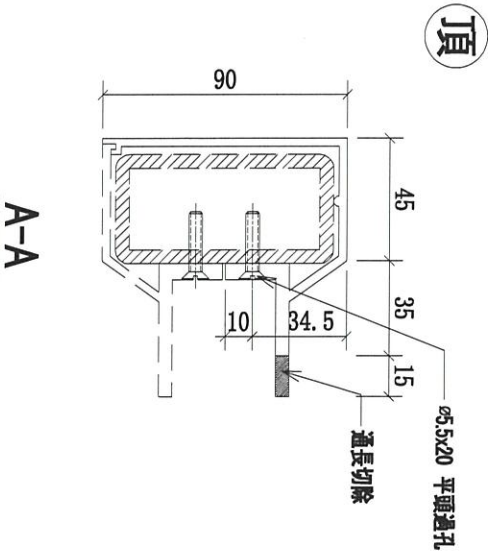

序號	物料編號	數量	L	A	M×N	使用位置	樓層
01	58-MS19-LTR01-A6(頂)	1	2384	142	300x7	SD-GB-5008	T1/(22F)
02	58A-MS20-LTR01-A6(頂)	1	2384	142	300x7	SD-GB-5008A	T3/(22F)
03	59-MS21-LTR01-A6(頂)	1	2384	142	300x7	SD-GB-5009	T3/(22F)
04	59A-MS22-LTR01-A6(頂)	1	2384	142	300x7	SD-GB-5009A	T1/(22F)
05	510-MS23-LTR01-A6(頂)	1	1218	159	300x3	SD-GB-5010	T1; T2; T3/(ROOF)
06	510-MS23-LTR02-A6(頂)	1	1100	100	300x3	SD-GB-5010	T1; T2; T3/(ROOF)
07	510-MS23-LTR03-A6(頂)	1	1218	159	300x3	SD-GB-5010	T1; T2; T3/(ROOF)
08	510A-MS24-LTR01-A6(頂)	1	1166	133	300x3	SD-GB-5010A	T1; T3/(ROOF)
09	510A-MS24-LTR02-A6(頂)	1	429	64.5	300x1	SD-GB-5010A	T1; T3/(ROOF)
10	510A-MS24-LTR03-A6(頂)	1	984	42	300x3	SD-GB-5010A	T1; T3/(ROOF)
11	510A-MS24-LTR04-A6(頂)	1	429	64.5	300x1	SD-GB-5010A	T1; T3/(ROOF)
12	510A-MS24-LTR05-A6(頂)	1	1166	133	300x3	SD-GB-5010A	T1; T3/(ROOF)

名稱	擱河鋁橫梁	制圖	CJM	2020.11.15	修改	A
材料	X85900(A6)	復核	-	-	日期	2020.02.23
顏色	PVF2 3-COATING FINISH	批準			圖號	58-MS19-LTR01-A6(頂)



美特鋁質有限公司

MIDI Aluminium Fabricator Ltd.

工程號

J-852

地盤

亞答老街/欄河

頂

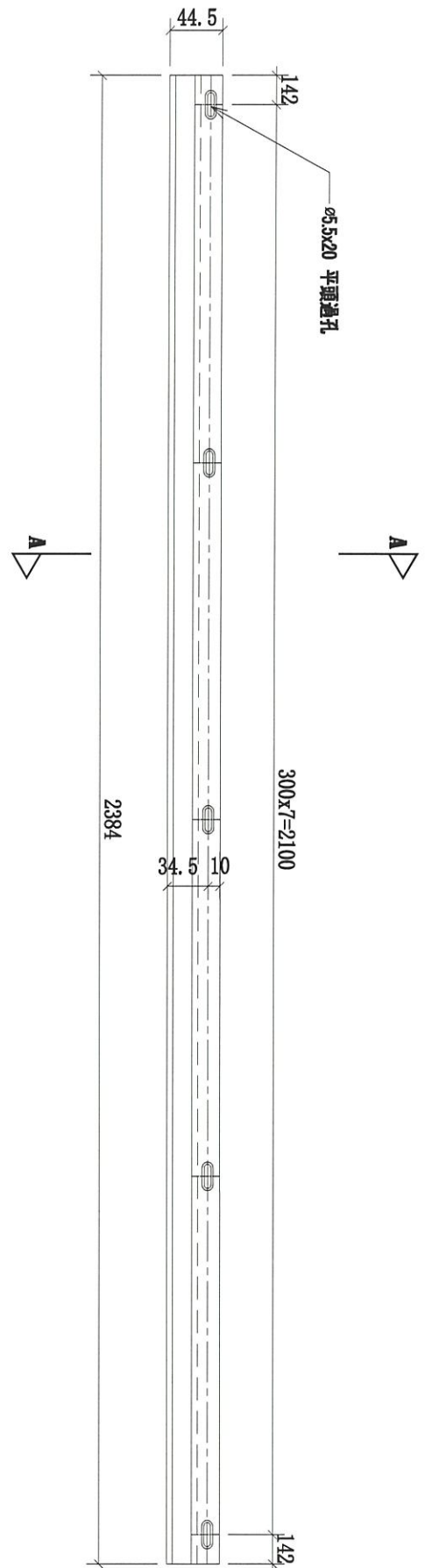
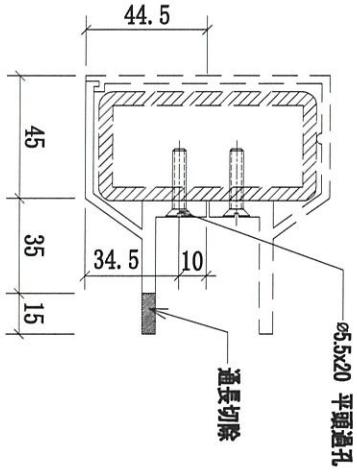

序號	物料編號	數量	L	A	MxN	使用位置	樓層
01	58-MS19-LTR01-A7(頂)	1	2384	142	300x7	SD-GB-5008	T1/(22F)
02	58A-MS20-LTR01-A7(頂)	1	2384	142	300x7	SD-GB-5008A	T3/(22F)
03	59-MS21-LTR01-A7(頂)	1	2384	142	300x7	SD-GB-5009	T3/(22F)
04	59A-MS22-LTR01-A7(頂)	1	2384	142	300x7	SD-GB-5009A	T1/(22F)
05	510-MS23-LTR01-A7(頂)	1	1218	159	300x3	SD-GB-5010	T1; T2; T3/(ROOF)
06	510-MS23-LTR02-A7(頂)	1	1100	100	300x3	SD-GB-5010	T1; T2; T3/(ROOF)
07	510-MS23-LTR03-A7(頂)	1	1218	159	300x3	SD-GB-5010	T1; T2; T3/(ROOF)
08	510A-MS24-LTR01-A7(頂)	1	1166	133	300x3	SD-GB-5010A	T1; T3/(ROOF)
09	510A-MS24-LTR02-A7(頂)	1	429	64.5	300x1	SD-GB-5010A	T1; T3/(ROOF)
10	510A-MS24-LTR03-A7(頂)	1	984	42	300x3	SD-GB-5010A	T1; T3/(ROOF)
11	510A-MS24-LTR04-A7(頂)	1	429	64.5	300x1	SD-GB-5010A	T1; T3/(ROOF)
12	510A-MS23-LTR05-A7(頂)	1	1166	133	300x3	SD-GB-5010A	T1; T3/(ROOF)

名稱	欄河鋁橫梁	制圖	CJM	2021.01.15	修改	A
材料	X85901(A7)	復核	-	-	日期	2020.02.23
顏色	PVF2 3-COATING FINISH	批準			圖號	58-MS19-LTR01-A7(頂)

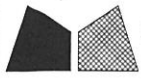

美特鋁質有限公司

MIDI Aluminium Fabricator Ltd.

工程號

J-852

地盤

亞皆老街/欄河

底

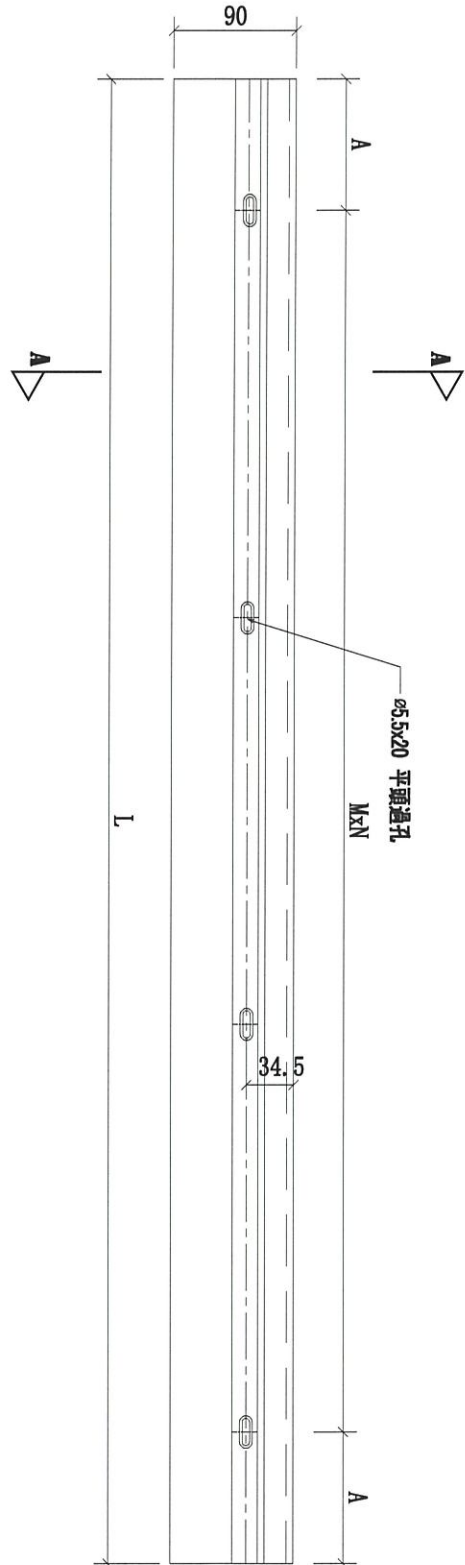
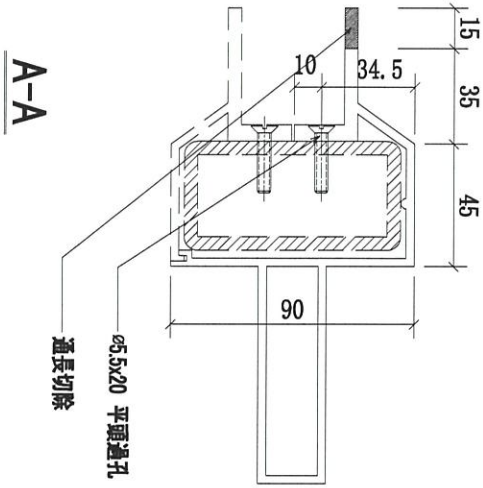

序號	物料編號	數量	L:	A:	M×N:	使用位置	樓層
01	58-MS19-LTR01-A8(底)	1	2384	142	300x7	SD-GB-5008	T1/(22F)
02	58A-MS20-LTR01-A8(底)	1	2384	142	300x7	SD-GB-5008A	T3/(22F)
03	59-MS21-LTR01-A8(底)	1	2384	142	300x7	SD-GB-5009	T3/(22F)
04	59A-MS22-LTR01-A8(底)	1	2384	142	300x7	SD-GB-5009A	T1/(22F)
05	510-MS23-LTR01-A8(底)	1	1218	159	300x3	SD-GB-5010	T1; T2; T3/(ROOF)
06	510-MS23-LTR02-A8(底)	1	1100	100	300x3	SD-GB-5010	T1; T2; T3/(ROOF)
07	510-MS23-LTR03-A8(底)	1	1218	159	300x3	SD-GB-5010	T1; T2; T3/(ROOF)
08	510A-MS24-LTR01-A8(底)	1	1166	133	300x3	SD-GB-5010A	T1; T3/(ROOF)
09	510A-MS23-LTR02-A8(底)	1	429	64.5	300x1	SD-GB-5010A	T1; T3/(ROOF)
10	510A-MS24-LTR03-A8(底)	1	984	42	300x3	SD-GB-5010A	T1; T3/(ROOF)
11	510A-MS24-LTR04-A8(底)	1	429	64.5	300x1	SD-GB-5010A	T1; T3/(ROOF)
12	510A-MS24-LTR05-A8(底)	1	1166	133	300x3	SD-GB-5010A	T1; T3/(ROOF)

名稱	欄河鋁橫梁	制圖	CJM	2021.01.15	修改	A	
材料	X85902(A8)	復核	-	-	日期	2020.02.23	
顏色	PVF2 3-COATING FINISH	批準			圖號	58-MS19-LTR01-A8(底)	

鋁材開料總表

工程號碼: J852 工程名稱: T3座1F~10F攔河鋁料

M01

序號	鋁料編號	名稱	表面處理		開料長度	實用長料總數量		浪費率(%)
			顏色	層厚		支數	長度	
1	X85895				5800	12	69600	10.32
2	X85896				5800	7	40600	7.77
3	X85897				5800	7	40600	7.77
4	X85898				5800	4	23200	19.23
5	X85899				5800	10	58000	13.88
6	X85900				5800	25	145000	3.86
7	X85901				5800	46	266800	2.57
8	X85902				5800	22	127600	5.51
9	X85903				5800	24	139200	9.80
10	X85904				5800	4	23200	19.23
11	X85905				5800	4	23200	19.23

送至: _____

由: _____

日期: _____

簡短說明: _____

共13頁 第1頁

打印日期: 23/2/2021 打印時間: 15:22

鋁材開料清單 X85905

窗號	編號(用料狀況)	實用長度(長料開數)	需要 支數	開料 支數	長料 支數	餘料 支數	編號(剩餘長度)
53B-MS03-LMU05(T3), 55A-MS09-LMU05, 56A- MS06-LMU05	1-3	1060.0	15	7	3	0	1@(440)x1 2-3@(4704)x2
55A-MS09-LMU05R, 56A- MS06-LMU05, 56A-MS06- LMU05R	(餘料)2, 2-3	1060.0		8	0	3	2@(3638)x1 2-3@(440)x2
53A-MS07-LMU05(T3)	4	870.0	3	1	1	0	4@(4894)x1
54A-MS08-LMU05(T3), 54A-MS08-LMU05R(T3)	(餘料)4, 4	870.0		2	0	2	4@(4018)x1 4@(3142)x1

鋁材開料清單 X85904

窗號	編號(用料狀況)	實用長度(長料開數)	需要 支數	開料 支數	長料 支數	餘料 支數	編號(剩餘長度)
53B-MS03-LMU04(T3), 55A-MS09-LMU04, 56A- MS06-LMU04	1-3	1060.0	15	7	3	0	1@(440)x1 2-3@(4704)x2
55A-MS09-LMU04R, 56A- MS06-LMU04, 56A-MS06- LMU04R	(餘料)2, 2-3	1060.0		8	0	3	2@(3638)x1 2-3@(440)x2
53A-MS07-LMU04(T3)	4	870.0	3	1	1	0	4@(4894)x1
54A-MS08-LMU04(T3), 54A-MS08-LMU04R(T3)	(餘料)4, 4	870.0		2	0	2	4@(4018)x1 4@(3142)x1

工程號碼:J852, 工程名稱:T3座1F~10F攔河鋁料
開料長度:5800, 總長料支數:24, 總開料支數:120
鋸片厚度(mm):6, 料頭尾總切除(mm):30, 浪費率(%):9.8

鋁材開料清單 X85903

窗號	編號(用料狀況)	實用長度(長料開數)	需要 支數	開料 支數	長料 支數	餘料 支數	編號(剩餘長度)
52B-MS02-LMU01-1(T3), 52B-MS02-LMU01-2(T3)	1-8	1075.0	40	40	8	0	1-8@(365)x8
51B-MS01-LMU04(T3), 51B-MS01-LMU04R(T3), 51B-MS01-LMU05(T3), 51B-MS01-LMU05R(T3), 52B-MS02-LMU03(T3), 52B-MS02-LMU03R(T3), 52B-MS02-LMU04(T3), 52B-MS02-LMU04R(T3)	9-20	1060.0	60	60	12	0	9-20@(440)x12
52A-MS05-LMU01-1(T3), 52-MS05-LMU01-2(T3)	21-22	885.0	8	4	2	0	21-22@(3988)x2
52A-MS05-LMU01-2(T3), 52-MS05-LMU01-1(T3)	(餘料)21, 21	885.0		4	0	2	21@(2206)x1 21@(424)x1
52A-MS05-LMU03(T3), 52- MS05-LMU04(T3)	23-24	870.0	12	2	2	0	23-24@(4894)x2
51A-MS01-LMU04(T3), 51A-MS01-LMU04R(T3), 51A-MS01-LMU05(T3), 51A-MS01-LMU05R(T3), 52A-MS05-LMU03R(T3), 52A-MS05-LMU04(T3), 52A-MS05-LMU04R(T3), 52-MS05-LMU03(T3), 52- MS05-LMU03R(T3), 52- MS05-LMU04R(T3)	(餘料)22, 22, 22, 22- 23, 23, 23, 23, 23-24	870.0		10	0	10	22@(3112)x1 22@(2236)x1 22@(1360)x1 22@(484)x1 23@(4018)x1 23@(3142)x1 23@(2266)x1 23@(1390)x1 23@(514)x1 24@(4018)x1

鋁材開料清單 X85902

窗號	編號(用料狀況)	實用長度(長料開數)	需要支數	開料支數	長料支數	餘料支數	編號(剩餘長度)
52A-MS05-LTR04-A8(T3), 52B-MS02-LTR04-A8(T3)	1-6	2704.0	12	10	6	0	1@(3060)x1 2-5@(350)x4 6@(3060)x1
52B-MS02-LTR04-A8(T3), 52-MS05-LTR04-A8(T3)	(餘料)1, 6	2704.0		2	0	2	1@(350)x1 6@(350)x1
54A-MS08-LTR16-A8(T3), 56A-MS06-LTR16-A8(T3)	7-9	2146.0	6	5	3	0	7@(3618)x1 8-9@(1466)x2
55A-MS09-LTR15-A6(T3)	(餘料)7	2146.0		1	0	1	7@(1466)x1
54A-MS08-LTR13-A8(T3), 56A-MS06-LTR13-A8(T3)	10-12	1946.0	6	5	3	0	10@(3818)x1 11-12@(1866)x2
55A-MS09-LTR12-A6(T3)	(餘料)10	1946.0		1	0	1	10@(1866)x1
54A-MS08-LTR15-A8(T3), 55A-MS09-LTR14-A6(T3), 56A-MS06-LTR15-A8(T3)	(餘料)7-12	1270.0	6	6	0	6	7-9@(190)x3 10-12@(590)x3
54A-MS08-LTR08-A8(T3), 56A-MS06-LTR02-A8(T3)	13-15	1249.0	12	10	3	0	13@(3260)x1 14-15@(750)x2
55A-MS09-LTR02-A8(T3)	(餘料)13	1249.0		2	0	1	13@(750)x1
54A-MS08-LTR17-A8(T3), 56A-MS06-LTR17-A8(T3)	16-17	1206.0	6	3	2	0	16@(4558)x1 17@(3346)x1
55A-MS09-LTR16-A6(T3), 56A-MS06-LTR17-A8(T3)	(餘料)16, 16	1206.0		3	0	2	16@(3346)x1 16@(922)x1
56A-MS06-LTR14-A8(T3)	18	1158.0	6	4	1	0	18@(1114)x1
54A-MS08-LTR14-A8(T3), 55A-MS09-LTR13-A6(T3)	(餘料)17, 17	1158.0		2	0	2	17@(2182)x1 17@(1018)x1
55A-MS09-LTR11-A6(T3)	19	1093.0	6	1	1	0	19@(4671)x1
54A-MS08-LTR12-A8(T3), 56A-MS06-LTR12-A8(T3)	(餘料)18-19	1093.0		5	0	2	18@(15)x1 19@(275)x1
51B-MS01-LTR05-A8(T3)	20	954.0	6	5	1	0	20@(970)x1
51A-MS01-LTR05-A8(T3)	(餘料)17	954.0		1	0	1	17@(58)x1
51B-MS01-LTR06-A8-A8(T3)	21	894.0	6	4	1	0	21@(2170)x1
51A-MS01-LTR06-A8-A8(T3), 51B-MS01-LTR06-A8-A8(T3)	(餘料)16, 20	894.0		2	0	2	16@(22)x1 20@(70)x1
51A-MS01-LTR04-A8(T3), 51B-MS01-LTR04-A8(T3)	(餘料)13-15, 21	594.0	6	6	0	4	13-15@(150)x3 21@(370)x1
52B-MS02-LTR03R-A8(T3)	22	179.0	24	1	1	0	22@(5585)x1
52A-MS05-LTR03-A8(T2), 52A-MS05-LTR03-A8(T3), 52B-MS02-LTR03-A8(T3), 52B-MS02-LTR03R-A8(T3), 52-MS05-LTR03-A8(T3)	(餘料)1-12, 19, 21-22, 22	179.0		23	0	16	1-6@(165)x6 7-9@(5)x3 10-12@(35)x3 19@(90)x1 21@(0)x1 22@(5400)x1 22@(5215)x1

鋁材開料清單 X85901

窗號	編號(用料狀況)	實用長度(長料開數)	需要支數	開料支數	長料支數	餘料支數	編號(剩餘長度)
52A-MS05-LTR02-A7(T3), 52B-MS02-LTR02-A7(T3), 52B-MS02-LTR04-A7(T3), 52-MS05-LTR02-A7(T3)	1-12	2704.0	24	22	12	0	1@(3060)x1 2-11@(350)x10 12@(3060)x1
52A-MS05-LTR04-A7(T3), 52-MS05-LTR04-A7(T3)	(餘料)1, 12	2704.0		2	0	2	1@(350)x1 12@(350)x1
53A-MS07-LMU01-A7(T3), 53B-MS03-LMU01-A7(T3)	13-15	2569.0	6	5	3	0	13@(3195)x1 14-15@(620)x2
53B-MS03-LMU01-A7(T3)	(餘料)13	2569.0		1	0	1	13@(620)x1
54A-MS08-LTR07-A7(T3), 55A-MS09-LTR07-A7(T3), 56A-MS06-LTR07-A7(T3), 56A-MS06-LTR16-A7(T3)	16-21	2146.0	12	10	6	0	16-17@(3618)x2 18-21@(1466)x4
54A-MS08-LTR16-A7(T3), 55A-MS09-LTR15-A7(T3)	(餘料)16-17	2146.0		2	0	2	16-17@(1466)x2
54A-MS08-LTR04-A7(T3), 55A-MS09-LTR04-A7(T3), 56A-MS06-LTR04-A7(T3), 56A-MS06-LTR13-A7(T3)	22-27	1946.0	12	10	6	0	22-23@(3818)x2 24-27@(1866)x4
54A-MS08-LTR13-A7(T3), 55A-MS09-LTR12-A7(T3)	(餘料)22-23	1946.0		2	0	2	22-23@(1866)x2
54A-MS08-LTR06-A7(T3), 54A-MS08-LTR15-A7(T3), 55A-MS09-LTR06-A7(T3), 55A-MS09-LTR14-A7(T3), 56A-MS06-LTR06-A7(T3), 56A-MS06-LTR15-A7(T3)	(餘料)16-27	1270.0	12	12	0	12	16-21@(190)x6 22-27@(590)x6
54A-MS08-LTR01-A7(T3), 55A-MS09-LTR01-A7(T3), 56A-MS06-LTR01-A7(T3), 56A-MS06-LTR02-A7(T3)	28-33	1249.0	24	20	6	0	28-29@(3260)x2 30-33@(750)x4
54A-MS08-LTR08-A7(T3), 55A-MS09-LTR02-A7(T3)	(餘料)28-29	1249.0		4	0	2	28-29@(750)x2
54A-MS08-LTR08-A7(T3), 56A-MS06-LTR08-A7(T3), 56A-MS06-LTR17-A7(T3)	34-36	1206.0	12	9	3	0	34@(4558)x1 35-36@(922)x2
54A-MS08-LTR17-A7(T3), 55A-MS09-LTR08-A7(T3), 55A-MS09-LTR16-A7(T3)	(餘料)34, 34, 34	1206.0		3	0	3	34@(3346)x1 34@(2134)x1 34@(922)x1
54A-MS08-LTR05-A7(T3), 56A-MS06-LTR05-A7(T3), 56A-MS06-LTR14-A7(T3)	37-39	1158.0	12	9	3	0	37@(4606)x1 38-39@(1114)x2
54A-MS08-LTR14-A7(T3), 55A-MS09-LTR05-A7(T3), 55A-MS09-LTR13-A7(T3)	(餘料)37, 37, 37	1158.0		3	0	3	37@(3442)x1 37@(2278)x1 37@(1114)x1
55A-MS09-LTR11-A7(T3), 56A-MS06-LTR12-A7(T3)	40-41	1093.0	12	5	2	0	40@(4671)x1 41@(1374)x1
54A-MS08-LTR03-A7(T3), 54A-MS08-LTR12-A7(T3), 55A-MS09-LTR03-A7(T3), 56A-MS06-LTR03-A7(T3)	(餘料)37-40	1093.0		7	0	4	37-39@(15)x3 40@(275)x1
51A-MS01-LTR05-A7(T3), 51B-MS01-LTR05-A7(T3)	42-43	954.0	12	6	2	0	42@(4810)x1 43@(970)x1
51A-MS01-LTR02-A7(T3), 51B-MS01-LTR02-A7(T3)	(餘料)41-42	954.0		6	0	2	41@(414)x1 42@(10)x1
51B-MS01-LTR03-A7(T3), 51B-MS01-LTR06-A7(T3)	44-45	894.0	12	5	2	0	44@(3070)x1 45@(3970)x1

工程號碼:J852, 工程名稱:T3座1F~10F攔河鋁料
開料長度:5800, 總長料支數:46, 總開料支數:216
鋸片厚度(mm):6, 料頭尾總切除(mm):30, 浪費率(%):2.57

鋁材開料清單 X85901

窗號	編號(用料狀況)	實用長度(長料開數)	需要支數	開料支數	長料支數	餘料支數	編號(剩餘長度)
51A-MS01-LTR03-A7(T3), 51A-MS01-LTR06-A7(T3), 51B-MS01-LTR03-A7(T3), 51B-MS01-LTR06-A7(T3)	(餘料)34-36, 43-44	894.0		7	0	5	34-36@(22)x3 43@(70)x1 44@(370)x1
51A-MS01-LTR01-A7(T3), 51A-MS01-LTR04-A7(T3), 51B-MS01-LTR01-A7(T3), 51B-MS01-LTR04-A7(T3)	(餘料)13-15, 28-33, 45	594.0	12	12	0	10	13-15@(20)x3 28-33@(150)x6 45@(2170)x1
53A-MS07-LMU02-A7(T3), 53B-MS03-LMU02-A7(T3)	(餘料)22-27	544.0	6	6	0	6	22-27@(40)x6
52B-MS02-LTR03R-A7(T3)	46	179.0	48	10	1	0	46@(3920)x1
52A-MS05-LTR01-A7(T3), 52A-MS05-LTR01R-A7(T3), 52A-MS05-LTR03-A6(T3), 52A-MS05-LTR03-A7(T3), 52B-MS02-LTR01-A7(T3), 52B-MS02-LTR01R-A7(T3), 52B-MS02-LTR03-A7(T3), 52-MS05-LTR01-A7(T3), 52-MS05-LTR01R-A7(T3), 52-MS05-LTR03-A6(T3), 52-MS05-LTR03-A7(T3)	(餘料)1-12, 16-21, 40-41, 44-45, 45-46, 46, 46, 46	179.0		38	0	27	1-12@(165)x12 16-21@(5)x6 40@(90)x1 41@(44)x1 44@(0)x1 45@(1985)x1 45@(135)x1 46@(3735)x1 46@(3550)x1 46@(3365)x1 46@(3180)x1

鋁材開料清單 X85900

窗號	編號(用料狀況)	實用長度(長料開數)	需要支數	開料支數	長料支數	餘料支數	編號(剩餘長度)
52A-MS05-LTR02-A6(T3), 52B-MS02-LTR02-A6(T3)	1-6	2704.0	12	10	6	0	1@(3060)x1 2-5@(350)x4 6@(3060)x1
52B-MS02-LTR02-A6(T3), 52-MS05-LTR02-A6(T3)	(餘料)1, 6	2704.0		2	0	2	1@(350)x1 6@(350)x1
53A-MS07-LMU01-A6(T3), 53B-MS03-LMU01-A6(T3)	7-9	2569.0	6	5	3	0	7@(3195)x1 8-9@(620)x2
53B-MS03-LMU01-A6(T3)	(餘料)7	2569.0		1	0	1	7@(620)x1
54A-MS08-LTR07-A6(T3), 56A-MS06-LTR07-A6(T3)	10-12	2146.0	6	5	3	0	10@(3618)x1 11-12@(1466)x2
55A-MS09-LTR07-A6(T3)	(餘料)10	2146.0		1	0	1	10@(1466)x1
54A-MS08-LTR04-A6(T3), 56A-MS06-LTR04-A6(T3)	13-15	1946.0	6	5	3	0	13@(3818)x1 14-15@(1866)x2
55A-MS09-LTR04-A6(T3)	(餘料)13	1946.0		1	0	1	13@(1866)x1
54A-MS08-LTR06-A6(T3), 55A-MS09-LTR06-A6(T3), 56A-MS06-LTR06-A6(T3)	(餘料)10-15	1270.0	6	6	0	6	10-12@(190)x3 13-15@(590)x3
54A-MS08-LTR01-A6(T3), 56A-MS06-LTR01-A6(T3)	16-18	1249.0	12	10	3	0	16@(3260)x1 17-18@(750)x2
55A-MS09-LTR01-A6(T3)	(餘料)16	1249.0		2	0	1	16@(750)x1
54A-MS08-LTR08-A6(T3), 56A-MS06-LTR08-A6(T3)	19-20	1206.0	6	3	2	0	19@(4558)x1 20@(3346)x1
55A-MS09-LTR08-A6(T3), 56A-MS06-LTR08-A6(T3)	(餘料)19, 19	1206.0		3	0	2	19@(3346)x1 19@(922)x1
56A-MS06-LTR05-A6(T3)	21	1158.0	6	4	1	0	21@(1114)x1
54A-MS08-LTR05-A6(T3), 55A-MS09-LTR05-A6(T3)	(餘料)20, 20	1158.0		2	0	2	20@(2182)x1 20@(1018)x1
55A-MS09-LTR03-A6(T3)	22	1093.0	6	1	1	0	22@(4671)x1
54A-MS08-LTR03-A6(T3), 56A-MS06-LTR03-A6(T3)	(餘料)21-22	1093.0		5	0	2	21@(15)x1 22@(275)x1
51B-MS01-LTR02-A6(T3)	23	954.0	6	5	1	0	23@(970)x1
51A-MS01-LTR02-A6(T3)	(餘料)20	954.0		1	0	1	20@(58)x1
51B-MS01-LTR03-A6(T3)	24	894.0	6	4	1	0	24@(2170)x1
51A-MS01-LTR03-A6(T3), 51B-MS01-LTR03-A6(T3)	(餘料)19, 23	894.0		2	0	2	19@(22)x1 23@(70)x1
51A-MS01-LTR01-A6(T3), 51B-MS01-LTR01-A6(T3)	(餘料)7-9, 16-18	594.0	6	6	0	6	7-9@(20)x3 16-18@(150)x3
53A-MS07-LMU02-A6(T3), 53B-MS03-LMU02-A6(T3)	(餘料)13-15, 24	544.0	6	6	0	4	13-15@(40)x3 24@(520)x1
52B-MS02-LTR01R-A6(T3)	25	179.0	24	10	1	0	25@(3920)x1
52A-MS05-LTR01-A6(T3), 52A-MS05-LTR01R-A6(T3), 52B-MS02-LTR01-A6(T3), 52-MS05-LTR01-A6(T3), 52-MS05-LTR01R-A6(T3)	(餘料)1-6, 10-12, 22, 24-25, 25	179.0		14	0	13	1-6@(165)x6 10-12@(5)x3 22@(90)x1 24@(150)x1 25@(3735)x1 25@(3550)x1

工程號碼:J852, 工程名稱:T3座1F~10F攔河鋁料

開料長度:5800, 總長料支數:10, 總開料支數:48

鋸片厚度(mm):6, 料頭尾總切除(mm):30, 浪費率(%):13.88

鋁材開料清單 X85899

窗號	編號(用料狀況)	實用長度(長料開數)	需要 支數	開料 支數	長料 支數	餘料 支數	編號(剩餘長度)
55A-MS09-LMU06, 55A-MS09-LMU07, 56A-MS06-LMU06, 56A-MS06-LMU07	1-8	1060.0	40	36	8	0	1@(1506)x1 2@(2572)x1 3-4@(440)x2 5@(1506)x1 6-8@(440)x3
55A-MS09-LMU07, 56A-MS06-LMU06, 56A-MS06-LMU07	(餘料)1-2, 5	1060.0		4	0	3	1-2@(440)x2 5@(440)x1
54A-MS08-LMU06(T3), 54A-MS08-LMU07(T3)	9-10	870.0	8	6	2	0	9@(2266)x1 10@(4018)x1
54A-MS08-LMU07(T3)	(餘料)9	870.0		2	0	1	9@(514)x1

鋁材開料清單 X85898

窗號	編號(用料狀況)	實用長度(長料開數)	需要 支數	開料 支數	長料 支數	餘料 支數	編號(剩餘長度)
53B-MS03-LMU03(T3), 55A-MS09-LMU03, 56A- MS06-LMU03	1-3	1060.0	15	7	3	0	1@(440)x1 2-3@(4704)x2
55A-MS09-LMU03R, 56A- MS06-LMU03, 56A-MS06- LMU03R	(餘料)2, 2-3	1060.0		8	0	3	2@(3638)x1 2-3@(440)x2
53A-MS07-LMU03(T3)	4	870.0	3	1	1	0	4@(4894)x1
54A-MS08-LMU03(T3), 54A-MS08-LMU03R(T3)	(餘料)4, 4	870.0		2	0	2	4@(4018)x1 4@(3142)x1

鋁材開料清單 X85897

窗號	編號(用料狀況)	實用長度(長料開數)	需要 支數	開料 支數	長料 支數	餘料 支數	編號(剩餘長度)
53B-MS03-LMU02(T3), 53B-MS03-LMU02R(T3), 55A-MS09-LMU02, 56A- MS06-LMU02, 56A-MS06- LMU02R	1-6	1060.0	30	24	6	0	1-2@(440)x2 3@(3638)x1 4@(440)x1 5@(3638)x1 6@(440)x1
55A-MS09-LMU02R, 56A- MS06-LMU02, 56A-MS06- LMU02R	(餘料)3, 3, 5	1060.0		6	0	3	3@(1506)x1 3@(440)x1 5@(440)x1
53A-MS07-LMU02(T3)	7	870.0	6	1	1	0	7@(4894)x1
53A-MS07-LMU02R(T3), 54A-MS08-LMU02(T3), 54A-MS08-LMU02R(T3)	(餘料)7, 7, 7	870.0		5	0	3	7@(4018)x1 7@(2266)x1 7@(514)x1

鋁材開料清單 X85896

窗號	編號(用料狀況)	實用長度(長料開數)	需要 支數	開料 支數	長料 支數	餘料 支數	編號(剩餘長度)
53B-MS03-LMU01(T3), 53B-MS03-LMU01R(T3), 55A-MS09-LMU01, 56A- MS06-LMU01, 56A-MS06- LMU01R	1-6	1060.0	30	24	6	0	1-2@(440)x2 3@(3638)x1 4@(440)x1 5@(3638)x1 6@(440)x1
55A-MS09-LMU01R, 56A- MS06-LMU01, 56A-MS06- LMU01R	(餘料)3, 3, 5	1060.0		6	0	3	3@(1506)x1 3@(440)x1 5@(440)x1
53A-MS07-LMU01(T3)	7	870.0	6	1	1	0	7@(4894)x1
53A-MS07-LMU01R(T3), 54A-MS08-LMU01(T3), 54A-MS08-LMU01R(T3)	(餘料)7, 7, 7	870.0		5	0	3	7@(4018)x1 7@(2266)x1 7@(514)x1

工程號碼:J852, 工程名稱:T3座1F~10F攔河鋁料
開料長度:5800, 總長料支數:12, 總開料支數:60
鋸片厚度(mm):6, 料頭尾總切除(mm):30, 浪費率(%):10.32

鋁材開料清單 X85895

窗號	編號(用料狀況)	實用長度(長料開數)	需要 支數	開料 支數	長料 支數	餘料 支數	編號(剩餘長度)
51B-MS01-LMU01(T3), 51B-MS01-LMU01R(T3), 51B-MS01-LMU02(T3), 51B-MS01-LMU02R(T3), 51B-MS01-LMU03(T3), 51B-MS01-LMU03R(T3), 52B-MS02-LMU02(T3), 52B-MS02-LMU02R(T3)	1-10	1060.0	50	50	10	0	1-10@(440)x10
51A-MS01-LMU01(T3), 52A-MS05-LMU02(T3), 51A-MS01-LMU01R(T3), 51A-MS01-LMU02(T3), 51A-MS01-LMU02R(T3), 51A-MS01-LMU03(T3), 51A-MS01-LMU03R(T3), 52A-MS05-LMU02R(T3), 52-MS05-LMU02(T3), 52- MS05-LMU02R(T3)	11-12, 11, 11, 11, 11, 11-12, 12, 12	870.0	10	10	2	8	11-12@(4894)x2 11@(4018)x1 11@(3142)x1 11@(2266)x1 11@(1390)x1 11@(514)x1 12@(4018)x1 12@(3142)x1 12@(2266)x1

鋁材開料總表

工程號碼: J852 工程名稱: MO2-T3座11F~23F攔河鋁料

序號	鋁料編號	名稱	表面處理		開料長度	實用長料總數量		浪費率(%)
			顏色	層厚		支數	長度	
1	X85895				5800	21	121800	10.21
2	X85896				5800	14	81200	8.57
3	X85897				5800	14	81200	8.57
4	X85898				5800	8	46400	15.34
5	X85899				5800	19	110200	10.49
6	X85900				5800	45	261000	1.34
7	X85901				5800	88	510400	2.04
8	X85902				5800	36	208800	2.58
9	X85903				5800	38	220400	8.06
10	X85904				5800	8	46400	15.34
11	X85905				5800	8	46400	15.34

送至: _____

由: _____

日期: _____

簡短說明: _____

共15頁 第1頁

打印日期: 23/2/2021 打印時間: 15:33

鋁材開料清單 X85905

窗號	編號(用料狀況)	實用長度(長料開數)	需要 支數	開料 支數	長料 支數	餘料 支數	編號(剩餘長度)
53B-MS03-LMU05(T3), 56A-MS06-LMU05, 56A- MS06-LMU05R, 57A-MS10- LMU05	1-7	1060.0	33	23	7	0	1-2@(440)x2 3@(4704)x1 4@(440)x1 5@(3638)x1 6@(1506)x1 7@(4704)x1
55A-MS09-LMU05, 55A- MS09-LMU05R, 56A-MS06- LMU05R, 57A-MS10-LMU05, 57A-MS10-LMU05R	(餘料)3, 3, 5-7	1060.0		10	0	5	3@(2572)x1 3@(440)x1 5-6@(440)x2 7@(2572)x1
510A-MS24-LMU05R	8	960.0	4	2	1	0	8@(3838)x1
510A-MS24-LMU05	(餘料)7	960.0		2	0	1	7@(640)x1

鋁材開料清單 X85904

窗號	編號(用料狀況)	實用長度(長料開數)	需要 支數	開料 支數	長料 支數	餘料 支數	編號(剩餘長度)
53B-MS03-LMU04(T3), 56A-MS06-LMU04, 56A- MS06-LMU04R, 57A-MS10- LMU04	1-7	1060.0	33	23	7	0	1-2@(440)x2 3@(4704)x1 4@(440)x1 5@(3638)x1 6@(1506)x1 7@(4704)x1
55A-MS09-LMU04, 55A- MS09-LMU04R, 56A-MS06- LMU04R, 57A-MS10-LMU04, 57A-MS10-LMU04R	(餘料)3, 3, 5-7	1060.0		10	0	5	3@(2572)x1 3@(440)x1 5-6@(440)x2 7@(2572)x1
510A-MS24-LMU04R	8	960.0	4	2	1	0	8@(3838)x1
510A-MS24-LMU04	(餘料)7	960.0		2	0	1	7@(640)x1

鋁材開料清單 X85903

窗號	編號(用料狀況)	實用長度(長料開數)	需要 支數	開料 支數	長料 支數	餘料 支數	編號(剩餘長度)
52B-MS02-LMU01-1(T3), 52B-MS02-LMU01-2(T3)	1-15	1075.0	72	68	15	0	1-7@(365)x7 8@(4689)x1 9-14@(365)x6 15@(3608)x1
52B-MS02-LMU01-2(T3)	(餘料)8	1075.0		4	0	1	8@(365)x1
51B-MS01-LMU04(T3), 51B-MS01-LMU04R(T3), 51B-MS01-LMU05(T3), 51B-MS01-LMU05R(T3), 52B-MS02-LMU03(T3), 52B-MS02-LMU03R(T3), 52B-MS02-LMU04(T3), 52B-MS02-LMU04R(T3)	16-38	1060.0	116	102	23	0	16@(440)x1 17@(2572)x1 18@(440)x1 19@(1506)x1 20-23@(440)x4 24@(4704)x1 25-26@(440)x2 27@(1506)x1 28-30@(440)x3 31@(3638)x1 32-37@(440)x6 38@(2572)x1
51B-MS01-LMU04(T3), 51B-MS01-LMU04R(T3), 51B-MS01-LMU05(T3), 52B-MS02-LMU03(T3), 52B-MS02-LMU03R(T3), 52B-MS02-LMU04(T3)	(餘料)15, 17, 19, 24, 27, 31	1060.0		14	0	6	15@(410)x1 17@(440)x1 19@(440)x1 24@(440)x1 27@(440)x1 31@(440)x1

鋁材開料清單 X85902

窗號	編號(用料狀況)	實用長度(長料開數)	需要支數	開料支數	長料支數	餘料支數	編號(剩餘長度)
52B-MS02-LTR04-A8(T3)	1-9	2704.0	18	18	9	0	1-9@(350)x9
58A-MS20-LTR01-A8	10	2384.0	2	1	1	0	10@(3380)x1
59-MS21-LTR01-A8	(餘料)10	2384.0		1	0	1	10@(990)x1
55A-MS09-LTR15-A6(T3), 56A-MS06-LTR16-A8(T3)	11-15	2146.0	9	9	5	0	11-14@(1466)x4 15@(3618)x1
55A-MS09-LTR12-A6(T3), 56A-MS06-LTR13-A8(T3)	16-19	1946.0	9	7	4	0	16@(3818)x1 17-19@(1866)x3
55A-MS09-LTR12-A6(T3), 56A-MS06-LTR13-A8(T3)	(餘料)15-16	1946.0		2	0	2	15@(1666)x1 16@(1866)x1
55A-MS09-LTR14-A6(T3), 56A-MS06-LTR15-A8(T3)	(餘料)11-19	1270.0	9	9	0	9	11-14@(190)x4 15@(390)x1 16-19@(590)x4
55A-MS09-LTR02-A8(T3), 56A-MS06-LTR02-A8(T3), 57A-MS10-LTR02-A8(T3)	20-25	1249.0	22	20	6	0	20-23@(750)x4 24-25@(3260)x2
57A-MS10-LTR02-A8(T3)	(餘料)24	1249.0		2	0	1	24@(750)x1
510-MS23-LTR01-A8, 510- MS23-LTR03-A8	(餘料)25, 25	1218.0	2	2	0	2	25@(2036)x1 25@(812)x1
55A-MS09-LTR16-A6(T3), 56A-MS06-LTR17-A8(T3)	26-28	1206.0	9	7	3	0	26@(3346)x1 27@(922)x1 28@(4558)x1
56A-MS06-LTR17-A8(T3)	(餘料)26	1206.0		2	0	1	26@(922)x1
510A-MS24-LTR01-A8, 510A-MS24-LTR05-A8	(餘料)28, 28	1166.0	2	2	0	2	28@(3386)x1 28@(2214)x1
55A-MS09-LTR13-A6(T3), 56A-MS06-LTR14-A8(T3)	29-30	1158.0	9	5	2	0	29@(4606)x1 30@(1114)x1
55A-MS09-LTR13-A6(T3), 56A-MS06-LTR14-A8(T3)	(餘料)28-29	1158.0		4	0	2	28@(1050)x1 29@(1114)x1
510-MS23-LTR02-A8	(餘料)29	1100.0	1	1	0	1	29@(8)x1
55A-MS09-LTR11-A6(T3), 56A-MS06-LTR12-A8(T3)	31-32	1093.0	9	4	2	0	31@(4671)x1 32@(2473)x1
55A-MS09-LTR11-A6(T3), 56A-MS06-LTR12-A8(T3)	(餘料)30-31	1093.0		5	0	2	30@(15)x1 31@(275)x1
510A-MS24-LTR03-A8	(餘料)10	984.0	1	1	0	1	10@(0)x1
51B-MS01-LTR05-A8(T3)	33-34	954.0	11	8	2	0	33@(10)x1 34@(3850)x1
51B-MS01-LTR05-A8(T3)	(餘料)28, 32	954.0		3	0	2	28@(90)x1 32@(553)x1
51B-MS01-LTR06-A8- A8(T3)	35	894.0	11	5	1	0	35@(1270)x1
51B-MS01-LTR06-A8- A8(T3)	(餘料)26-27, 34	894.0		6	0	3	26-27@(22)x2 34@(250)x1
51B-MS01-LTR04-A8(T3)	36	594.0	11	3	1	0	36@(3970)x1
51B-MS01-LTR04-A8(T3)	(餘料)20-25, 35	594.0		8	0	7	20-24@(150)x5 25@(212)x1 35@(70)x1
510A-MS24-LTR02-A8, 510A-MS24-LTR04-A8	(餘料)16-17	429.0	2	2	0	2	16-17@(155)x2
52B-MS02-LTR03-A8(T3), 52B-MS02-LTR03R-A8(T3)	(餘料)1-9, 11-15, 18- 19, 25, 31-32, 34, 36	179.0	36	36	0	21	1-9@(165)x9 11-14@(5)x4 15@(20)x1 18-19@(35)x2 25@(27)x1 31@(90)x1 32@(183)x1 34@(65)x1 36@(2120)x1

鋁材開料清單 X85901

窗號	編號(用料狀況)	實用長度(長料開數)	需要 支數	開料 支數	長料 支數	餘料 支數	編號(剩餘長度)
57A-MS10-LTR05-A7(T3), 57A-MS10-LTR13-A7(T3), 57A-MS10-LTR13-A8(T3)	1-6	3294.0	6	6	6	0	1-6@(2470)x6
52B-MS02-LTR02-A7(T3), 52B-MS02-LTR04-A7(T3)	7-24	2704.0	36	36	18	0	7-24@(350)x18
53B-MS03-LMU01-A7(T3)	25-30	2569.0	11	11	6	0	25-29@(620)x5 30@(3195)x1
58A-MS20-LTR01-A7, 58A- MS20-LTR01-A7(底), 59- MS21-LTR01-A7, 59-MS21- LTR01-A7(底)	(餘料)1-4	2384.0	4	4	0	4	1-4@(80)x4
55A-MS09-LTR15-A7(T3), 56A-MS06-LTR07-A7(T3), 56A-MS06-LTR16-A7(T3), 57A-MS10-LTR06-A7(T3), 57A-MS10-LTR14-A7(T3), 57A-MS10-LTR14-A8(T3)	31-41	2146.0	24	17	11	0	31@(3618)x1 32-37@(1466)x6 38-41@(3618)x4
55A-MS09-LTR07-A7(T3), 55A-MS09-LTR15-A7(T3), 56A-MS06-LTR07-A7(T3), 57A-MS10-LTR06-A7(T3), 57A-MS10-LTR14-A7(T3), 57A-MS10-LTR14-A8(T3)	(餘料)5-6, 30-31, 38-40	2146.0		7	0	7	5-6@(318)x2 30@(1043)x1 31@(1466)x1 38-40@(1466)x3
55A-MS09-LTR04-A7(T3), 55A-MS09-LTR12-A7(T3), 56A-MS06-LTR04-A7(T3), 56A-MS06-LTR13-A7(T3), 57A-MS10-LTR04-A7(T3), 57A-MS10-LTR12-A7(T3), 57A-MS10-LTR12-A8(T3)	42-53	1946.0	24	18	12	0	42-43@(3818)x2 44-49@(1866)x6 50-53@(3818)x4
55A-MS09-LTR04-A7(T3), 55A-MS09-LTR12-A7(T3), 56A-MS06-LTR04-A7(T3), 57A-MS10-LTR04-A7(T3), 57A-MS10-LTR12-A7(T3), 57A-MS10-LTR12-A8(T3)	(餘料)41-43, 50-52	1946.0		6	0	6	41@(1666)x1 42-43@(1866)x2 50-52@(1866)x3
55A-MS09-LTR06-A7(T3), 55A-MS09-LTR14-A7(T3), 56A-MS06-LTR06-A7(T3), 56A-MS06-LTR15-A7(T3)	(餘料)31-48	1270.0	18	18	0	18	31-40@(190)x10 41@(390)x1 42-48@(590)x7
55A-MS09-LTR02-A7(T3), 56A-MS06-LTR01-A7(T3), 56A-MS06-LTR02-A7(T3), 57A-MS10-LTR01-A7(T3), 57A-MS10-LTR02-A7(T3)	54-63	1249.0	44	27	10	0	54@(4515)x1 55-56@(750)x2 57@(2005)x1 58-60@(750)x3 61-63@(4515)x3
55A-MS09-LTR01-A7(T3), 55A-MS09-LTR02-A7(T3), 56A-MS06-LTR01-A7(T3), 56A-MS06-LTR02-A7(T3), 57A-MS10-LTR01-A7(T3), 57A-MS10-LTR02-A7(T3)	(餘料)49-54, 57, 61-62	1249.0		17	0	9	49-52@(611)x4 53@(53)x1 54@(750)x1 57@(750)x1 61-62@(750)x2
510-MS23-LTR03-A7(底)	64	1218.0	4	1	1	0	64@(4546)x1
510-MS23-LTR01-A7, 510- MS23-LTR01-A7(底), 510-MS23-LTR03-A7	(餘料)63, 63, 63	1218.0		3	0	3	63@(3291)x1 63@(2067)x1 63@(843)x1

鋁材開料清單 X85901

窗號	編號(用料狀況)	實用長度(長料開數)	需要支數	開料支數	長料支數	餘料支數	編號(剩餘長度)
55A-MS09-LTR16-A7(T3), 56A-MS06-LTR08-A7(T3), 56A-MS06-LTR17-A7(T3), 57A-MS10-LTR07-A7(T3), 57A-MS10-LTR15-A8(T3)	65-70	1206.0	24	14	6	0	65@(4558)x1 66-67@(922)x2 68@(2134)x1 69-70@(4558)x2
55A-MS09-LTR08-A7(T3), 55A-MS09-LTR16-A7(T3), 56A-MS06-LTR08-A7(T3), 57A-MS10-LTR07-A7(T3), 57A-MS10-LTR15-A7(T3), 57A-MS10-LTR15-A8(T3)	(餘料)64, 64-65, 68-69, 69	1206.0		10	0	6	64@(2122)x1 64@(910)x1 65@(922)x1 68@(922)x1 69@(2134)x1 69@(922)x1
510A-MS24-LTR05-A7(底)	71	1166.0	4	1	1	0	71@(4598)x1
510A-MS24-LTR01-A7, 510A-MS24-LTR01-A7(底), 510A-MS24-LTR05-A7	(餘料)70, 70, 70	1166.0		3	0	3	70@(3386)x1 70@(2214)x1 70@(1042)x1
55A-MS09-LTR13-A7(T3), 56A-MS06-LTR05-A7(T3), 56A-MS06-LTR14-A7(T3)	72-75	1158.0	18	12	4	0	72@(4606)x1 73-74@(1114)x2 75@(2278)x1
55A-MS09-LTR05-A7(T3), 55A-MS09-LTR13-A7(T3), 56A-MS06-LTR05-A7(T3)	(餘料)71, 71-72	1158.0		6	0	3	71@(2270)x1 71@(1106)x1 72@(1114)x1
510-MS23-LTR02-A7, 510-MS23-LTR02-A7(底)	(餘料)71-72	1100.0	2	2	0	2	71@(0)x1 72@(8)x1
56A-MS06-LTR03-A7(T3), 56A-MS06-LTR12-A7(T3), 57A-MS10-LTR03-A7(T3)	76-79	1093.0	24	12	4	0	76@(275)x1 77@(3572)x1 78@(1374)x1 79@(4671)x1
55A-MS09-LTR03-A7(T3), 55A-MS09-LTR11-A7(T3), 56A-MS06-LTR12-A7(T3), 57A-MS10-LTR03-A7(T3), 57A-MS10-LTR11-A7(T3), 57A-MS10-LTR11-A8(T3)	(餘料)73-75, 77-79, 79	1093.0		12	0	7	73-74@(15)x2 75@(80)x1 77-78@(275)x2 79@(2473)x1 79@(275)x1
510A-MS24-LTR03-A7, 510A-MS24-LTR03-A7(底)	(餘料)30, 70	984.0	2	2	0	2	30@(53)x1 70@(52)x1
51B-MS01-LTR02-A7(T3), 51B-MS01-LTR05-A7(T3)	80-83	954.0	22	21	4	0	80@(10)x1 81@(970)x1 82@(10)x1 83@(1930)x1
51B-MS01-LTR05-A7(T3)	(餘料)81	954.0		1	0	1	81@(10)x1
51B-MS01-LTR03-A7(T3), 51B-MS01-LTR06-A7(T3)	84-86	894.0	22	11	3	0	84@(3070)x1 85@(370)x1 86@(3970)x1
51B-MS01-LTR03-A7(T3), 51B-MS01-LTR06-A7(T3)	(餘料)64-69, 83-84	894.0		11	0	8	64@(10)x1 65-69@(22)x5 83@(130)x1 84@(370)x1
51B-MS01-LTR01-A7(T3), 51B-MS01-LTR04-A7(T3)	(餘料)25-29, 49-52, 54-63, 86	594.0	22	22	0	20	25-29@(20)x5 49-52@(11)x4 54-62@(150)x9 63@(243)x1 86@(2170)x1
53B-MS03-LMU02-A7(T3)	87	544.0	11	1	1	0	87@(5220)x1
53B-MS03-LMU02-A7(T3)	(餘料)42-48, 86	544.0		10	0	8	42-48@(40)x7 86@(520)x1

工程號碼:J852, 工程名稱:M02-T3座11F~23F攔河鋁料

開料長度:5800, 總長料支數:88, 總開料支數:398

鋸片厚度(mm):6, 料頭尾總切除(mm):30, 浪費率(%):2.04

鋁材開料清單 X85901

窗號	編號(用料狀況)	實用長度(長料開數)	需要支數	開料支數	長料支數	餘料支數	編號(剩餘長度)
510A-MS24-LTR02-A7, 510A-MS24-LTR02-A7(底), 510A-MS24-LTR04-A7, 510A-MS24-LTR04-A7(底)	(餘料)86-87, 87, 87	429.0	4	4	0	4	86@(85)x1 87@(4785)x1 87@(4350)x1 87@(3915)x1
52B-MS02-LTR03R-A7(T3)	88	179.0	72	10	1	0	88@(3920)x1
52B-MS02-LTR01-A7(T3), 52B-MS02-LTR01R-A7(T3), 52B-MS02-LTR03-A7(T3), 52B-MS02-LTR03R-A7(T3)	(餘料)5-24, 31-41, 63, 76-79, 84-85, 87, 87	179.0		62	0	40	5-6@(133)x2 7-24@(165)x18 31-40@(5)x10 41@(20)x1 63@(58)x1 76-79@(90)x4 84-85@(0)x2 87@(1510)x1 87@(30)x1

鋁材開料清單 X85900

窗號	編號(用料狀況)	實用長度(長料開數)	需要支數	開料支數	長料支數	餘料支數	編號(剩餘長度)
57A-MS10-LTR05-A6(T3)	1-2	3294.0	2	2	2	0	1-2@(2470)x2
52B-MS02-LTR02-A6(T3)	3-11	2704.0	18	18	9	0	3-11@(350)x9
53B-MS03-LMU01-A6(T3)	12-17	2569.0	11	11	6	0	12-16@(620)x5 17@(3195)x1
58A-MS20-LTR01-A6, 59-MS21-LTR01-A6	(餘料)1-2	2384.0	2	2	0	2	1-2@(80)x2
55A-MS09-LTR07-A6(T3), 56A-MS06-LTR07-A6(T3), 57A-MS10-LTR06-A6(T3)	18-22	2146.0	11	9	5	0	18@(3618)x1 19-22@(1466)x4
55A-MS09-LTR07-A6(T3), 56A-MS06-LTR07-A6(T3)	(餘料)17-18	2146.0		2	0	2	17@(1043)x1 18@(1466)x1
55A-MS09-LTR04-A6(T3), 56A-MS06-LTR04-A6(T3), 57A-MS10-LTR04-A6(T3)	23-28	1946.0	11	10	6	0	23-26@(1866)x4 27-28@(3818)x2
57A-MS10-LTR04-A6(T3)	(餘料)27	1946.0		1	0	1	27@(1866)x1
55A-MS09-LTR06-A6(T3), 56A-MS06-LTR06-A6(T3)	(餘料)18-26	1270.0	9	9	0	9	18-22@(190)x5 23-26@(590)x4
56A-MS06-LTR01-A6(T3), 57A-MS10-LTR01-A6(T3)	29-33	1249.0	22	16	5	0	29-31@(750)x3 32-33@(3260)x2
55A-MS09-LTR01-A6(T3), 57A-MS10-LTR01-A6(T3)	(餘料)27-28, 32	1249.0		6	0	3	27@(611)x1 28@(53)x1 32@(750)x1
510-MS23-LTR01-A6, 510-MS23-LTR03-A6	(餘料)33, 33	1218.0	2	2	0	2	33@(2036)x1 33@(812)x1
55A-MS09-LTR08-A6(T3), 56A-MS06-LTR08-A6(T3)	34-36	1206.0	11	7	3	0	34@(3346)x1 35@(922)x1 36@(4558)x1
56A-MS06-LTR08-A6(T3), 57A-MS10-LTR07-A6(T3)	(餘料)34, 36	1206.0		4	0	2	34@(922)x1 36@(2134)x1
510A-MS24-LTR05-A6	37	1166.0	2	1	1	0	37@(4598)x1
510A-MS24-LTR01-A6	(餘料)36	1166.0		1	0	1	36@(962)x1
56A-MS06-LTR05-A6(T3)	38-39	1158.0	9	6	2	0	38@(1114)x1 39@(3442)x1
55A-MS09-LTR05-A6(T3), 56A-MS06-LTR05-A6(T3)	(餘料)37, 37	1158.0		3	0	2	37@(2270)x1 37@(1106)x1
510-MS23-LTR02-A6	(餘料)37	1100.0	1	1	0	1	37@(0)x1
56A-MS06-LTR03-A6(T3), 57A-MS10-LTR03-A6(T3)	40-41	1093.0	11	7	2	0	40@(275)x1 41@(3572)x1
55A-MS09-LTR03-A6(T3), 56A-MS06-LTR03-A6(T3)	(餘料)38-39, 39	1093.0		4	0	3	38@(15)x1 39@(2343)x1 39@(145)x1
510A-MS24-LTR03-A6	(餘料)17	984.0	1	1	0	1	17@(53)x1
51B-MS01-LTR02-A6(T3)	42-43	954.0	11	7	2	0	42@(10)x1 43@(4810)x1
51B-MS01-LTR02-A6(T3)	(餘料)36, 41	954.0		4	0	2	36@(2)x1 41@(692)x1
51B-MS01-LTR03-A6(T3)	44	894.0	11	4	1	0	44@(2170)x1
51B-MS01-LTR03-A6(T3)	(餘料)34-35, 43	894.0		7	0	3	34-35@(22)x2 43@(310)x1
51B-MS01-LTR01-A6(T3)	(餘料)12-16, 27, 29-33	594.0	11	11	0	11	12-16@(20)x5 27@(11)x1 29-32@(150)x4 33@(212)x1
53B-MS03-LMU02-A6(T3)	45	544.0	11	3	1	0	45@(4120)x1
53B-MS03-LMU02-A6(T3)	(餘料)23-26, 41, 44	544.0		8	0	6	23-26@(40)x4 41@(142)x1 44@(520)x1

工程號碼:J852, 工程名稱:MO2-T3座11F~23F攔河鋁料
開料長度:5800, 總長料支數:45, 總開料支數:205
鋸片厚度(mm):6, 料頭尾總切除(mm):30, 浪費率(%):1.34

鋁材開料清單 X85900

窗號	編號(用料狀況)	實用長度(長料開數)	需要 支數	開料 支數	長料 支數	餘料 支數	編號(剩餘長度)
510A-MS24-LTR02-A6, 510A-MS24-LTR04-A6	(餘料)44-45	429.0	2	2	0	2	44@(85)x1 45@(3685)x1
52B-MS02-LTR01-A6(T3), 52B-MS02-LTR01R-A6(T3)	(餘料)3-11, 18-22, 33, 40, 43, 45, 45	179.0	36	36	0	19	3-11@(165)x9 18-22@(5)x5 33@(27)x1 40@(90)x1 43@(125)x1 45@(3500)x1 45@(170)x1

工程號碼:J852, 工程名稱:MO2-T3座11F~23F攔河鋁料

開料長度:5800, 總長料支數:19, 總開料支數:92

鋸片厚度(mm):6, 料頭尾總切除(mm):30, 浪費率(%):10.49

鋁材開料清單 X85899

窗號	編號(用料狀況)	實用長度(長料開數)	需要 支數	開料 支數	長料 支數	餘料 支數	編號(剩餘長度)
510-MS23-LMU03, 55A-MS09-LMU06, 55A-MS09-LMU07, 56A-MS06-LMU06, 56A-MS06-LMU07, 57A-MS10-LMU06, 57A-MS10-LMU07, 510-MS23-LMU04, 55A-MS09-LMU06, 55A-MS09-LMU07, 56A-MS06-LMU07, 57A-MS10-LMU06, 57A-MS10-LMU07	1-19, 1, 1, 3, 10, 16-17	1060.0	92	92	19	6	1@(3638)x1 2@(440)x1 3@(3638)x1 4-9@(440)x6 10@(2572)x1 11-15@(440)x5 16@(4704)x1 17@(1506)x1 18@(440)x1 19@(3638)x1 1@(1506)x1 1@(440)x1 3@(440)x1 10@(440)x1 16-17@(440)x2

鋁材開料清單 X85898

窗號	編號(用料狀況)	實用長度(長料開數)	需要 支數	開料 支數	長料 支數	餘料 支數	編號(剩餘長度)
53B-MS03-LMU03(T3), 56A-MS06-LMU03, 56A- MS06-LMU03R, 57A-MS10- LMU03	1-7	1060.0	33	23	7	0	1-2@(440)x2 3@(4704)x1 4@(440)x1 5@(3638)x1 6@(1506)x1 7@(4704)x1
55A-MS09-LMU03, 55A- MS09-LMU03R, 56A-MS06- LMU03R, 57A-MS10-LMU03, 57A-MS10-LMU03R	(餘料)3, 3, 5-7	1060.0		10	0	5	3@(2572)x1 3@(440)x1 5-6@(440)x2 7@(2572)x1
510A-MS24-LMU03R	8	960.0	4	2	1	0	8@(3838)x1
510A-MS24-LMU03	(餘料)7	960.0		2	0	1	7@(640)x1

鋁材開料清單 X85897

窗號	編號(用料狀況)	實用長度(長料開數)	需要 支數	開料 支數	長料 支數	餘料 支數	編號(剩餘長度)
53B-MS03-LMU02(T3), 53B-MS03-LMU02R(T3), 55A-MS09-LMU02, 56A- MS06-LMU02, 56A-MS06- LMU02R, 57A-MS10-LMU02R	1-13	1060.0	62	48	13	0	1-2@(440)x2 3@(4704)x1 4@(440)x1 5@(3638)x1 6@(4704)x1 7-8@(440)x2 9@(1506)x1 10-11@(440)x2 12@(2572)x1 13@(3638)x1
53B-MS03-LMU02R(T3), 55A-MS09-LMU02, 55A- MS09-LMU02R, 56A-MS06- LMU02R, 57A-MS10-LMU02	(餘料)3, 5-6, 9, 12	1060.0		14	0	5	3@(440)x1 5-6@(440)x2 9@(440)x1 12@(440)x1
510-MS23-LMU02R	14	960.0	8	1	1	0	14@(4804)x1
510A-MS24-LMU02, 510A- MS24-LMU02R, 510-MS23- LMU02, 58A-MS20-LMU02, 58A-MS20-LMU02R, 59- MS21-LMU02, 59-MS21- LMU02R	(餘料)13, 13, 13-14, 14, 14, 14	960.0		7	0	7	13@(2672)x1 13@(1706)x1 13@(740)x1 14@(3838)x1 14@(2872)x1 14@(1906)x1 14@(940)x1

工程號碼:J852, 工程名稱:MO2-T3座11F~23F攔河鋁料

開料長度:5800, 總長料支數:14, 總開料支數:70

鋸片厚度(mm):6, 料頭尾總切除(mm):30, 浪費率(%):8.57

鋁材開料清單 X85896

窗號	編號(用料狀況)	實用長度(長料開數)	需要 支數	開料 支數	長料 支數	餘料 支數	編號(剩餘長度)
53B-MS03-LMU01(T3), 53B-MS03-LMU01R(T3), 55A-MS09-LMU01, 56A- MS06-LMU01, 56A-MS06- LMU01R, 57A-MS10-LMU01R	1-13	1060.0	62	48	13	0	1-2@(440)x2 3@(4704)x1 4@(440)x1 5@(3638)x1 6@(4704)x1 7-8@(440)x2 9@(1506)x1 10-11@(440)x2 12@(2572)x1 13@(3638)x1
53B-MS03-LMU01R(T3), 55A-MS09-LMU01, 55A- MS09-LMU01R, 56A-MS06- LMU01R, 57A-MS10-LMU01	(餘料)3, 5-6, 9, 12	1060.0		14	0	5	3@(440)x1 5-6@(440)x2 9@(440)x1 12@(440)x1
510-MS23-LMU01R	14	960.0	8	1	1	0	14@(4804)x1
510A-MS24-LMU01, 510A- MS24-LMU01R, 510-MS23- LMU01, 58A-MS20-LMU01, 58A-MS20-LMU01R, 59- MS21-LMU01, 59-MS21- LMU01R	(餘料)13, 13, 13-14, 14, 14, 14	960.0		7	0	7	13@(2672)x1 13@(1706)x1 13@(740)x1 14@(3838)x1 14@(2872)x1 14@(1906)x1 14@(940)x1

鋁材開料清單 X85895

窗號	編號(用料狀況)	實用長度(長料開數)	需要 支數	開料 支數	長料 支數	餘料 支數	編號(剩餘長度)
51B-MS01-LMU01(T3), 51B-MS01-LMU01R(T3), 51B-MS01-LMU02(T3), 51B-MS01-LMU02R(T3), 51B-MS01-LMU03(T3), 51B-MS01-LMU03R(T3), 52B-MS02-LMU02(T3), 52B-MS02-LMU02R(T3), 51B-MS01-LMU01R(T3), 51B-MS01-LMU02(T3), 51B-MS01-LMU02R(T3), 51B-MS01-LMU03(T3), 52B-MS02-LMU02(T3), 52B-MS02-LMU02R(T3)	1-21, 3, 5, 7, 9, 14, 17	1060.0	102	102	21	6	1-2@(440)x2 3@(4704)x1 4@(440)x1 5@(3638)x1 6@(440)x1 7@(2572)x1 8@(440)x1 9@(1506)x1 10-13@(440)x4 14@(4704)x1 15-16@(440)x2 17@(1506)x1 18-20@(440)x3 21@(3638)x1 3@(440)x1 5@(440)x1 7@(440)x1 9@(440)x1 14@(440)x1 17@(440)x1

鋁材開料總表

工程號碼: J852 工程名稱: MO3-T1T2座1F~10F攔河鋁料

序號	鋁料編號	名稱	表面處理		開料長度	實用長料總數量		浪費率(%)
			顏色	層厚		支數	長度	
1	X85895				5800	24	139200	10.32
2	X85896				5800	14	81200	7.77
3	X85897				5800	14	81200	7.77
4	X85898				5800	7	40600	7.77
5	X85899				5800	19	110200	9.38
6	X85900				5800	49	284200	2.80
7	X85901				5800	91	527800	2.47
8	X85902				5800	42	243600	2.08
9	X85903				5800	47	272600	7.89
10	X85904				5800	7	40600	7.77
11	X85905				5800	7	40600	7.77

送至: _____

由: _____

日期: _____

簡短說明: _____

共16頁 第1頁

打印日期: 23/2/2021 打印時間: 15:43

工程號碼: J852, 工程名稱: M03-T1T2座1F~10F攔河鋁料
開料長度: 5800, 總長料支數: 7, 總開料支數: 36
鋸片厚度(mm): 6, 料頭尾總切除(mm): 30, 浪費率(%): 7.77

鋁材開料清單 X85905

窗號	編號(用料狀況)	實用長度(長料開數)	需要 支數	開料 支數	長料 支數	餘料 支數	編號(剩餘長度)
53B-MS03-LMU05(T1), 53B-MS03-LMU05(T2), 55B-MS09-LMU05, 56B- MS06-LMU05, 56B-MS06- LMU05R, 56-MS06-LMU05	1-6	1060.0	30	17	6	0	1-2@(440)x2 3@(4704)x1 4@(2572)x1 5@(3638)x1 6@(4704)x1
55B-MS09-LMU05R, 55- MS09-LMU05, 55-MS09- LMU05R, 56B-MS06-LMU05, 56B-MS06-LMU05R, 56- MS06-LMU05, 56-MS06- LMU05R	(餘料)3, 3, 3, 3-6	1060.0		13	0	7	3@(3638)x1 3@(2572)x1 3@(1506)x1 3-6@(440)x4
53-MS07-LMU05(T1)	7	870.0	6	1	1	0	7@(4894)x1
53-MS07-LMU05(T2), 54B- MS08-LMU05(T1), 54B- MS08-LMU05R(T1), 54- MS08-LMU05(T2), 54- MS08-LMU05R(T2)	(餘料)7, 7, 7, 7, 7	870.0		5	0	5	7@(4018)x1 7@(3142)x1 7@(2266)x1 7@(1390)x1 7@(514)x1

鋁材開料清單 X85904

窗號	編號(用料狀況)	實用長度(長料開數)	需要 支數	開料 支數	長料 支數	餘料 支數	編號(剩餘長度)
53B-MS03-LMU04(T1), 53B-MS03-LMU04(T2), 55B-MS09-LMU04, 56B- MS06-LMU04, 56B-MS06- LMU04R, 56-MS06-LMU04	1-6	1060.0	30	17	6	0	1-2@(440)x2 3@(4704)x1 4@(2572)x1 5@(3638)x1 6@(4704)x1
55B-MS09-LMU04R, 55- MS09-LMU04, 55-MS09- LMU04R, 56B-MS06-LMU04, 56B-MS06-LMU04R, 56- MS06-LMU04, 56-MS06- LMU04R	(餘料)3, 3, 3, 3-6	1060.0		13	0	7	3@(3638)x1 3@(2572)x1 3@(1506)x1 3-6@(440)x4
53-MS07-LMU04(T1)	7	870.0	6	1	1	0	7@(4894)x1
53-MS07-LMU04(T2), 54B- MS08-LMU04(T1), 54B- MS08-LMU04R(T1), 54- MS08-LMU04(T2), 54- MS08-LMU04R(T2)	(餘料)7, 7, 7, 7, 7	870.0		5	0	5	7@(4018)x1 7@(3142)x1 7@(2266)x1 7@(1390)x1 7@(514)x1

鋁材開料清單 X85903

窗號	編號(用料狀況)	實用長度(長料開數)	需要 支數	開料 支數	長料 支數	餘料 支數	編號(剩餘長度)
52B-MS02-LMU01-1(T1), 52B-MS02-LMU01-1(T2), 52B-MS02-LMU01-2(T1), 52B-MS02-LMU01-2(T2)	1-16	1075.0	80	80	16	0	1-16@(365)x16
51B-MS01-LMU04(T1), 51B-MS01-LMU04(T2), 51B-MS01-LMU04R(T1), 51B-MS01-LMU04R(T2), 51B-MS01-LMU05(T1), 51B-MS01-LMU05(T2), 51B-MS01-LMU05R(T1), 51B-MS01-LMU05R(T2), 52B-MS02-LMU03(T1), 52B-MS02-LMU03(T2), 52B-MS02-LMU03R(T1), 52B-MS02-LMU03R(T2), 52B-MS02-LMU04(T1), 52B-MS02-LMU04(T2), 52B-MS02-LMU04R(T1), 52B-MS02-LMU04R(T2)	17-40	1060.0	120	120	24	0	17-40@(440)x24
52A-MS05-LMU01-1(T1), 52A-MS05-LMU01-1(T2), 52A-MS05-LMU01-2(T2)	41-43	885.0	16	10	3	0	41@(2206)x1 42@(3988)x1 43@(2206)x1
52A-MS05-LMU01-1(T2), 52A-MS05-LMU01-2(T1)	(餘料)41-42	885.0		6	0	2	41-42@(424)x2
51-MS01-LMU04R(T1), 52A-MS05-LMU03(T1), 52A-MS05-LMU03R(T2), 52A-MS05-LMU04R(T1)	44-47	870.0	24	7	4	0	44@(4894)x1 45-47@(4018)x3
51-MS01-LMU04(T1), 51- MS01-LMU04(T2), 51- MS01-LMU04R(T2), 51- MS01-LMU05(T1), 51- MS01-LMU05(T2), 51- MS01-LMU05R(T1), 51- MS01-LMU05R(T2), 52A- MS05-LMU03(T2), 52A- MS05-LMU03R(T1), 52A- MS05-LMU04(T1), 52A- MS05-LMU04(T2), 52A- MS05-LMU04R(T2)	(餘料)43, 43-44, 44, 44, 44, 44-45, 45-46, 46-47	870.0		17	0	12	43@(1330)x1 43@(454)x1 44@(4018)x1 44@(3142)x1 44@(2266)x1 44@(1390)x1 44@(514)x1 45@(2266)x1 45@(514)x1 46@(2266)x1 46@(514)x1 47@(2266)x1

鋁材開料清單 X85902

窗號	編號(用料狀況)	實用長度(長料開數)	需要支數	開料支數	長料支數	餘料支數	編號(剩餘長度)
52A-MS05-LTR04-A8(T1), 52A-MS05-LTR04-A8(T2), 52B-MS02-LTR04-A8(T1), 52B-MS02-LTR04-A8(T2)	1-12	2704.0	24	24	12	0	1-12@(350)x12
54B-MS04-LTR16-A8(T1), 56B-MS06-LTR16-A8(T1)	13-15	2146.0	6	5	3	0	13@(3618)x1 14-15@(1466)x2
55B-MS09-LTR15-A6(T1)	(餘料)13	2146.0		1	0	1	13@(1466)x1
54B-MS04-LTR13-A8(T1), 56B-MS06-LTR13-A8(T1)	16-18	1946.0		5	3	0	16@(3818)x1 17-18@(1866)x2
55B-MS09-LTR12-A6(T1)	(餘料)16	1946.0	12	1	0	1	16@(1866)x1
54-MS08-LTR19-A8(T2), 55-MS09-LTR18-A6(T2), 56-MS06-LTR19-A8(T2)	19-22	1896.0		9	4	0	19@(1966)x1 20@(3868)x1 21-22@(64)x2
55-MS09-LTR18-A6(T2), 56-MS06-LTR19-A8(T2)	(餘料)19-20	1896.0		3	0	2	19-20@(64)x2
54B-MS04-LTR15-A8(T1), 55B-MS09-LTR14-A6(T1), 56B-MS06-LTR15-A8(T1)	(餘料)13-18	1270.0	6	6	0	6	13-15@(190)x3 16-18@(590)x3
54B-MS08-LTR08-A8(T1), 55B-MS09-LTR02-A8(T1), 56B-MS06-LTR02-A8(T1), 56-MS06-LTR02-A8(T2)	23-28	1249.0	24	20	6	0	23-24@(3260)x2 25-28@(750)x4
54-MS08-LTR08-A8(T2), 55-MS09-LTR02-A8(T2)	(餘料)23-24	1249.0		4	0	2	23-24@(750)x2
54B-MS04-LTR17-A8(T1), 56B-MS06-LTR17-A8(T1)	29-30	1206.0	6	3	2	0	29@(4558)x1 30@(3346)x1
55B-MS09-LTR16-A6(T1), 56B-MS06-LTR17-A8(T1)	(餘料)29, 29	1206.0		3	0	2	29@(3346)x1 29@(922)x1
55-MS09-LTR17-A6(T2), 56-MS06-LTR18-A8(T2)	31-33	1168.0		8	3	0	31@(3422)x1 32@(1074)x1 33@(3422)x1
54-MS08-LTR18-A8(T3), 56-MS06-LTR18-A8(T2)	(餘料)30-31	1168.0	12	4	0	2	30@(998)x1 31@(1074)x1
56B-MS06-LTR14-A8(T1)	34	1158.0		4	1	0	34@(1114)x1
54B-MS04-LTR14-A8(T1), 55B-MS09-LTR13-A6(T1)	(餘料)33, 33	1158.0		2	0	2	33@(2258)x1 33@(1094)x1
54-MS08-LTR20-A8(T2), 56-MS06-LTR20-A8(T2)	35-37	1133.0	12	9	3	0	35@(3492)x1 36@(75)x1 37@(3492)x1
55-MS09-LTR19-A6(T2), 56-MS06-LTR20-A8(T2)	(餘料)35, 35	1133.0		3	0	2	35@(1214)x1 35@(75)x1
56B-MS06-LTR12-A8(T1)	38	1093.0		2	1	0	38@(3572)x1
54B-MS04-LTR12-A8(T1), 55B-MS09-LTR11-A6(T1), 56B-MS06-LTR12-A8(T1)	(餘料)34, 37, 37	1093.0	12	4	0	3	34@(15)x1 37@(2393)x1 37@(195)x1
51B-MS01-LTR05-A8(T2)	39	954.0		3	1	0	39@(2890)x1
51B-MS01-LTR05-A8(T1), 51B-MS01-LTR05-A8(T2), 51-MS01-LTR05-A8(T1), 51-MS01-LTR05-A8(T2)	(餘料)30-33, 38, 38-39, 39	954.0		9	0	8	30@(38)x1 31-32@(114)x2 33@(134)x1 38@(2612)x1 38@(692)x1 39@(1930)x1 39@(970)x1
51B-MS01-LTR06-A8-A8(T1), 51B-MS01-LTR06-A8-A8(T2)	40-41	894.0	12	5	2	0	40@(3070)x1 41@(3970)x1

鋁材開料清單 X85902

窗號	編號(用料狀況)	實用長度(長料開數)	需要支數	開料支數	長料支數	餘料支數	編號(剩餘長度)
51B-MS01-LTR06-A8-A8(T1), 51B-MS01-LTR06-A8-A8(T2), 51-MS01-LTR06-A8-A8(T1), 51-MS01-LTR06-A8-A8(T2)	(餘料)29, 39-41, 41	894.0		7	0	5	29@(22)x1 39@(70)x1 40@(370)x1 41@(3070)x1 41@(2170)x1
51-MS01-LTR04-A8(T1)	42	594.0	12	1	1	0	42@(5170)x1
51B-MS01-LTR04-A8(T1), 51B-MS01-LTR04-A8(T2), 51-MS01-LTR04-A8(T2)	(餘料)23-28, 38, 41-42	594.0		11	0	9	23-28@(150)x6 38@(92)x1 41@(370)x1 42@(4570)x1
52A-MS05-LTR03-A8(T1), 52A-MS05-LTR03-A8(T2), 52B-MS02-LTR03-A8(T1), 52B-MS02-LTR03-A8(T2), 52B-MS02-LTR03R-A8(T1), 52B-MS02-LTR03R-A8(T2)	(餘料)1-18, 37, 40-41, 41-42, 42	179.0	48	48	0	24	1-12@(165)x12 13-15@(5)x3 16-18@(35)x3 37@(10)x1 40@(0)x1 41@(185)x1 41@(0)x1 42@(2905)x1 42@(1055)x1

鋁材開料清單 X85901

窗號	編號(用料狀況)	實用長度(長料開數)	需要支數	開料支數	長料支數	餘料支數	編號(剩餘長度)
52A-MS05-LTR02-A7(T1), 52A-MS05-LTR02-A7(T2), 52A-MS05-LTR04-A7(T1), 52A-MS05-LTR04-A7(T2), 52B-MS02-LTR02-A7(T1), 52B-MS02-LTR02-A7(T2), 52B-MS02-LTR04-A7(T1), 52B-MS02-LTR04-A7(T2)	1-24	2704.0	48	48	24	0	1-24@(350)x24
53B-MS03-LMU01-A7(T1), 53B-MS03-LMU01-A7(T2), 53-MS07-LMU01-A7(T1)	25-30	2569.0	12	10	6	0	25-26@(620)x2 27@(3195)x1 28-29@(620)x2 30@(3195)x1
53B-MS03-LMU01-A7(T2), 53-MS07-LMU01-A7(T2)	(餘料)27, 30	2569.0		2	0	2	27@(620)x1 30@(620)x1
54B-MS04-LTR07-A7(T1), 55B-MS09-LTR07-A7(T1), 56B-MS06-LTR07-A7(T1), 56B-MS06-LTR16-A7(T1)	31-36	2146.0	12	10	6	0	31-32@(3618)x2 33-36@(1466)x4
54B-MS04-LTR16-A7(T1), 55B-MS09-LTR15-A7(T1)	(餘料)31-32	2146.0		2	0	2	31-32@(1466)x2
54B-MS04-LTR04-A7(T1), 55B-MS09-LTR04-A7(T1), 56B-MS06-LTR04-A7(T1), 56B-MS06-LTR13-A7(T1)	37-42	1946.0	12	10	6	0	37-38@(3818)x2 39-42@(1866)x4
54B-MS04-LTR13-A7(T1), 55B-MS09-LTR12-A7(T1)	(餘料)37-38	1946.0		2	0	2	37-38@(1866)x2
54-MS08-LTR10-A7(T2), 54-MS08-LTR19-A7(T2), 55-MS09-LTR18-A7(T2), 56-MS06-LTR10-A7(T2), 56-MS06-LTR19-A7(T2)	43-50	1896.0	24	18	8	0	43@(1966)x1 44@(3868)x1 45@(1966)x1 46-47@(64)x2 48@(3868)x1 49-50@(64)x2
54-MS08-LTR19-A7(T2), 55-MS09-LTR10-A7(T2), 56-MS06-LTR10-A7(T2), 56-MS06-LTR19-A7(T2)	(餘料)43-45, 48	1896.0		6	0	4	43-45@(64)x3 48@(64)x1
54B-MS04-LTR06-A7(T1), 54B-MS04-LTR15-A7(T1), 55B-MS09-LTR06-A7(T1), 55B-MS09-LTR14-A7(T1), 56B-MS06-LTR06-A7(T1), 56B-MS06-LTR15-A7(T1)	(餘料)31-42	1270.0	12	12	0	12	31-36@(190)x6 37-42@(590)x6
54B-MS08-LTR01-A7(T1), 54-MS08-LTR01-A7(T2), 55B-MS09-LTR01-A7(T1), 55-MS09-LTR01-A7(T2), 56B-MS06-LTR01-A7(T1), 56B-MS06-LTR02-A7(T1), 56-MS06-LTR01-A7(T2), 56-MS06-LTR02-A7(T2)	51-62	1249.0	48	40	12	0	51-54@(3260)x4 55-62@(750)x8
54B-MS08-LTR08-A7(T1), 54-MS08-LTR08-A7(T2), 55B-MS09-LTR02-A7(T1), 55-MS09-LTR02-A7(T2)	(餘料)51-54	1249.0		8	0	4	51-54@(750)x4
54B-MS04-LTR08-A7(T1), 56B-MS06-LTR08-A7(T1), 56B-MS06-LTR17-A7(T1)	63-65	1206.0	12	9	3	0	63@(4558)x1 64-65@(922)x2

鋁材開料清單 X85901

窗號	編號(用料狀況)	實用長度(長料開數)	需要支數	開料支數	長料支數	餘料支數	編號(剩餘長度)
54B-MS04-LTR17-A7(T1), 55B-MS09-LTR08-A7(T1), 55B-MS09-LTR16-A7(T1)	(餘料)63, 63, 63	1206.0		3	0	3	63@(3346)x1 63@(2134)x1 63@(922)x1
54-MS08-LTR09-A7(T2), 55-MS09-LTR09-A7(T2), 56-MS06-LTR09-A7(T2), 56-MS06-LTR18-A7(T2)	66-71	1168.0	24	20	6	0	66-67@(3422)x2 68-71@(1074)x4
54-MS08-LTR18-A7(T3), 55-MS09-LTR17-A7(T2)	(餘料)66-67	1168.0		4	0	2	66-67@(1074)x2
54B-MS04-LTR05-A7(T1), 56B-MS06-LTR05-A7(T1), 56B-MS06-LTR14-A7(T1)	72-74	1158.0	12	9	3	0	72@(4606)x1 73-74@(1114)x2
54B-MS04-LTR14-A7(T1), 55B-MS09-LTR05-A7(T1), 55B-MS09-LTR13-A7(T1)	(餘料)72, 72, 72	1158.0		3	0	3	72@(3442)x1 72@(2278)x1 72@(1114)x1
54-MS08-LTR11-A7(T2), 55-MS09-LTR11-A7(T2), 56-MS06-LTR11-A7(T2), 56-MS06-LTR20-A7(T2)	75-79	1133.0	24	13	5	0	75@(3492)x1 76@(4631)x1 77@(75)x1 78@(4631)x1 79@(1214)x1
54-MS08-LTR20-A7(T2), 55-MS09-LTR11-A7(T2), 55-MS09-LTR19-A7(T2), 56-MS06-LTR11-A7(T2), 56-MS06-LTR20-A7(T2)	(餘料)75, 75-76, 76, 78	1133.0		11	0	5	75@(1214)x1 75@(75)x1 76@(2353)x1 76@(75)x1 78@(75)x1
56B-MS06-LTR03-A7(T1), 56B-MS06-LTR12-A7(T1)	80-81	1093.0	12	7	2	0	80@(1374)x1 81@(2473)x1
54B-MS04-LTR03-A7(T1), 54B-MS04-LTR12-A7(T1), 55B-MS09-LTR03-A7(T1), 55B-MS09-LTR11-A7(T1), 56B-MS06-LTR12-A7(T1)	(餘料)72-74, 79-80	1093.0		5	0	5	72-74@(15)x3 79@(115)x1 80@(275)x1
51B-MS01-LTR02-A7(T2), 51B-MS01-LTR05-A7(T1), 51-MS01-LTR02-A7(T1)	82-84	954.0	24	4	3	0	82@(3850)x1 83-84@(4810)x2
51B-MS01-LTR02-A7(T1), 51B-MS01-LTR02-A7(T2), 51B-MS01-LTR05-A7(T1), 51B-MS01-LTR05-A7(T2), 51-MS01-LTR02-A7(T2), 51-MS01-LTR05-A7(T1), 51-MS01-LTR05-A7(T2)	(餘料)66-71, 81-84, 84, 84	954.0		20	0	12	66-71@(114)x6 81@(553)x1 82-83@(10)x2 84@(3850)x1 84@(2890)x1 84@(1930)x1
51B-MS01-LTR03-A7(T2), 51B-MS01-LTR06-A7(T1), 51B-MS01-LTR06-A7(T2), 51-MS01-LTR06-A7(T2)	85-88	894.0	24	13	4	0	85@(1270)x1 86@(2170)x1 87@(3070)x1 88@(4870)x1
51B-MS01-LTR03-A7(T1), 51B-MS01-LTR06-A7(T1), 51B-MS01-LTR06-A7(T2), 51-MS01-LTR03-A7(T1), 51-MS01-LTR03-A7(T2), 51-MS01-LTR06-A7(T1)	(餘料)63-65, 84-87, 87, 87	894.0		11	0	9	63-65@(22)x3 84@(130)x1 85-86@(370)x2 87@(2170)x1 87@(1270)x1 87@(370)x1

鋁材開料清單 X85901

窗號	編號(用料狀況)	實用長度(長料開數)	需要支數	開料支數	長料支數	餘料支數	編號(剩餘長度)
51B-MS01-LTR01-A7(T1), 51B-MS01-LTR01-A7(T2), 51B-MS01-LTR04-A7(T1), 51B-MS01-LTR04-A7(T2), 51-MS01-LTR01-A7(T1), 51-MS01-LTR01-A7(T2), 51-MS01-LTR04-A7(T1), 51-MS01-LTR04-A7(T2)	(餘料)25-30, 51-62, 88, 88, 88, 88, 88	594.0	24	24	0	23	25-30@(20)x6 51-62@(150)x12 88@(3670)x1 88@(3070)x1 88@(2470)x1 88@(1870)x1 88@(1270)x1
5B3-MS03-LMU02-A7(T2)	89	544.0	12	3	1	0	89@(4120)x1
53B-MS03-LMU02-A7(T1), 53-MS07-LMU02-A7(T1), 53-MS07-LMU02-A7(T2), 5B3-MS03-LMU02-A7(T2)	(餘料)37-42, 81, 88	544.0		9	0	8	37-42@(40)x6 81@(3)x1 88@(170)x1
52B-MS02-LTR03-A7(T1), 52B-MS02-LTR03R-A7(T2)	90-91	179.0	96	13	2	0	90@(4475)x1 91@(4660)x1
52A-MS05-LTR01-A7(T1), 52A-MS05-LTR01-A7(T2), 52A-MS05-LTR01R-A7(T1), 52A-MS05-LTR01R-A7(T2), 52A-MS05-LTR03-A6(T1), 52A-MS05-LTR03-A6(T2), 52A-MS05-LTR03-A7(T1), 52A-MS05-LTR03-A7(T2), 52B-MS02-LTR01-A7(T1), 52B-MS02-LTR01-A7(T2), 52B-MS02-LTR01R-A7(T1), 52B-MS02-LTR01R-A7(T2), 52B-MS02-LTR03-A7(T1), 52B-MS02-LTR03-A7(T2), 52B-MS02-LTR03R-A7(T1), 52B-MS02-LTR03R-A7(T2)	(餘料)1-24, 31-36, 80, 85-87, 87, 89, 89, 89- 90, 90, 90	179.0		83	0	41	1-24@(165)x24 31-36@(5)x6 80@(90)x1 85-86@(0)x2 87@(185)x1 87@(0)x1 89@(2455)x1 89@(605)x1 89@(50)x1 90@(2625)x1 90@(775)x1 90@(35)x1

鋁材開料清單 X85900

窗號	編號(用料狀況)	實用長度(長料開數)	需要支數	開料支數	長料支數	餘料支數	編號(剩餘長度)
52A-MS05-LTR02-A6(T1), 52A-MS05-LTR02-A6(T2), 52B-MS02-LTR02-A6(T1), 52B-MS02-LTR02-A6(T2)	1-12	2704.0	24	24	12	0	1-12@(350)x12
53B-MS03-LMU01-A6(T1), 53B-MS03-LMU01-A6(T2), 53-MS07-LMU01-A6(T1)	13-18	2569.0	12	10	6	0	13-14@(620)x2 15@(3195)x1 16-17@(620)x2 18@(3195)x1
53B-MS03-LMU01-A6(T2), 53-MS07-LMU01-A6(T2)	(餘料)15, 18	2569.0		2	0	2	15@(620)x1 18@(620)x1
54B-MS04-LTR07-A6(T1), 56B-MS06-LTR07-A6(T1)	19-21	2146.0	6	5	3	0	19@(3618)x1 20-21@(1466)x2
55B-MS09-LTR07-A6(T1)	(餘料)19	2146.0		1	0	1	19@(1466)x1
54B-MS04-LTR04-A6(T1), 56B-MS06-LTR04-A6(T1)	22-24	1946.0	6	5	3	0	22@(3818)x1 23-24@(1866)x2
55B-MS09-LTR04-A6(T1)	(餘料)22	1946.0		1	0	1	22@(1866)x1
54-MS08-LTR10-A6(T2), 55-MS09-LTR10-A6(T2), 56-MS06-LTR10-A6(T2)	25-28	1896.0	12	9	4	0	25@(1966)x1 26@(3868)x1 27-28@(64)x2
55-MS09-LTR10-A6(T2), 56-MS06-LTR10-A6(T2)	(餘料)25-26	1896.0		3	0	2	25-26@(64)x2
54B-MS04-LTR06-A6(T1), 55B-MS09-LTR06-A6(T1), 56B-MS06-LTR06-A6(T1)	(餘料)19-24	1270.0	6	6	0	6	19-21@(190)x3 22-24@(590)x3
54B-MS08-LTR01-A6(T1), 55B-MS09-LTR01-A6(T1), 56B-MS06-LTR01-A6(T1), 56-MS06-LTR01-A6(T2)	29-34	1249.0	24	20	6	0	29-30@(3260)x2 31-34@(750)x4
54-MS08-LTR01-A6(T2), 55-MS09-LTR01-A6(T2)	(餘料)29-30	1249.0		4	0	2	29-30@(750)x2
54B-MS04-LTR08-A6(T1), 56B-MS06-LTR08-A6(T1)	35-36	1206.0	6	3	2	0	35@(4558)x1 36@(3346)x1
55B-MS09-LTR08-A6(T1), 56B-MS06-LTR08-A6(T1)	(餘料)35, 35	1206.0		3	0	2	35@(3346)x1 35@(922)x1
55-MS09-LTR09-A6(T2), 56-MS06-LTR09-A6(T2)	37-39	1168.0	12	8	3	0	37@(3422)x1 38@(1074)x1 39@(3422)x1
54-MS08-LTR09-A6(T2), 56-MS06-LTR09-A6(T2)	(餘料)36-37	1168.0		4	0	2	36@(998)x1 37@(1074)x1
56B-MS06-LTR05-A6(T1)	40	1158.0	6	4	1	0	40@(1114)x1
54B-MS04-LTR05-A6(T1), 55B-MS09-LTR05-A6(T1)	(餘料)39, 39	1158.0		2	0	2	39@(2258)x1 39@(1094)x1
54-MS08-LTR11-A6(T2), 56-MS06-LTR11-A6(T2)	41-43	1133.0	12	9	3	0	41@(3492)x1 42@(75)x1 43@(3492)x1
55-MS09-LTR11-A6(T2), 56-MS06-LTR11-A6(T2)	(餘料)41, 41	1133.0		3	0	2	41@(1214)x1 41@(75)x1
56B-MS06-LTR03-A6(T1)	44	1093.0	6	2	1	0	44@(3572)x1
54B-MS04-LTR03-A6(T1), 55B-MS09-LTR03-A6(T1), 56B-MS06-LTR03-A6(T1)	(餘料)40, 43, 43	1093.0		4	0	3	40@(15)x1 43@(2393)x1 43@(195)x1
51B-MS01-LTR02-A6(T2)	45	954.0	12	3	1	0	45@(2890)x1

鋁材開料清單 X85900

窗號	編號(用料狀況)	實用長度(長料開數)	需要支數	開料支數	長料支數	餘料支數	編號(剩餘長度)
51B-MS01-LTR02-A6(T1), 51B-MS01-LTR02-A6(T2), 51-MS01-LTR02-A6(T1), 51-MS01-LTR02-A6(T2)	(餘料)36-39, 44, 44-45, 45	954.0		9	0	8	36@(38)x1 37-38@(114)x2 39@(134)x1 44@(2612)x1 44@(692)x1 45@(1930)x1 45@(970)x1
51B-MS01-LTR03-A6(T1), 51B-MS01-LTR03-A6(T2)	46-47	894.0	12	5	2	0	46@(3070)x1 47@(3970)x1
51B-MS01-LTR03-A6(T1), 51B-MS01-LTR03-A6(T2), 51-MS01-LTR03-A6(T1), 51-MS01-LTR03-A6(T2)	(餘料)35, 45-47, 47	894.0		7	0	5	35@(22)x1 45@(70)x1 46@(370)x1 47@(3070)x1 47@(2170)x1
51B-MS01-LTR01-A6(T1), 51B-MS01-LTR01-A6(T2), 51-MS01-LTR01-A6(T1), 51-MS01-LTR01-A6(T2)	(餘料)13-18, 29-34	594.0	12	12	0	12	13-18@(20)x6 29-34@(150)x6
53B-MS03-LMU02-A6(T2)	48	544.0	12	3	1	0	48@(4120)x1
53B-MS03-LMU02-A6(T1), 53B-MS03-LMU02-A6(T2), 53-MS07-LMU02-A6(T1), 53-MS07-LMU02-A6(T2)	(餘料)22-24, 44, 47, 47-48, 48	544.0		9	0	8	22-24@(40)x3 44@(142)x1 47@(1620)x1 47@(520)x1 48@(3570)x1 48@(3020)x1
52B-MS02-LTR01R-A6(T1)	49	179.0	48	2	1	0	49@(5400)x1
52A-MS05-LTR01-A6(T1), 52A-MS05-LTR01-A6(T2), 52A-MS05-LTR01R-A6(T1), 52A-MS05-LTR01R-A6(T2), 52B-MS02-LTR01-A6(T1), 52B-MS02-LTR01-A6(T2), 52B-MS02-LTR01R-A6(T1), 52B-MS02-LTR01R-A6(T2)	(餘料)1-12, 19-21, 43, 46-48, 48-49	179.0		46	0	21	1-12@(165)x12 19-21@(5)x3 43@(10)x1 46@(0)x1 47@(150)x1 48@(1540)x1 48@(60)x1 49@(3550)x1

工程號碼: J852, 工程名稱: M03-T1T2座1F~10F攔河鋁料
開料長度: 5800, 總長料支數: 19, 總開料支數: 96
鋸片厚度(mm): 6, 料頭尾總切除(mm): 30, 浪費率(%): 9.38

鋁材開料清單 X85899

窗號	編號(用料狀況)	實用長度(長料開數)	需要 支數	開料 支數	長料 支數	餘料 支數	編號(剩餘長度)
55B-MS09-LMU06, 55B-MS09-LMU07, 55-MS09-LMU06, 55-MS09-LMU07, 56B-MS06-LMU06, 56B-MS06-LMU07, 56-MS06-LMU06, 56-MS06-LMU07	1-16	1060.0	80	64	16	0	1@(1506)x1 2@(2572)x1 3@(3638)x1 4@(4704)x1 5-6@(440)x2 7@(3638)x1 8-9@(440)x2 10@(2572)x1 11-12@(440)x2 13@(1506)x1 14-16@(440)x3
55B-MS09-LMU07, 55-MS09-LMU06, 55-MS09-LMU07, 56B-MS06-LMU06, 56B-MS06-LMU07, 56-MS06-LMU06, 56-MS06-LMU07	(餘料)1-4, 7, 10, 13	1060.0		16	0	7	1-4@(440)x4 7@(440)x1 10@(440)x1 13@(440)x1
54B-MS08-LMU06(T1), 54B-MS08-LMU07(T1), 54-MS08-LMU07(T2)	17-19	870.0	16	10	3	0	17@(2266)x1 18@(4018)x1 19@(2266)x1
54B-MS08-LMU07(T1), 54-MS08-LMU06(T2)	(餘料)17-18	870.0		6	0	2	17-18@(514)x2

鋁材開料清單 X85898

窗號	編號(用料狀況)	實用長度(長料開數)	需要 支數	開料 支數	長料 支數	餘料 支數	編號(剩餘長度)
53B-MS03-LMU03(T1), 53B-MS03-LMU03(T2), 55B-MS09-LMU03, 56B- MS06-LMU03, 56B-MS06- LMU03R, 56-MS06-LMU03	1-6	1060.0	30	17	6	0	1-2@(440)x2 3@(4704)x1 4@(2572)x1 5@(3638)x1 6@(4704)x1
55B-MS09-LMU03R, 55- MS09-LMU03, 55-MS09- LMU03R, 56B-MS06-LMU03, 56B-MS06-LMU03R, 56- MS06-LMU03, 56-MS06- LMU03R	(餘料)3, 3, 3, 3-6	1060.0		13	0	7	3@(3638)x1 3@(2572)x1 3@(1506)x1 3-6@(440)x4
53-MS07-LMU03(T1)	7	870.0	6	1	1	0	7@(4894)x1
53-MS07-LMU03(T2), 54B- MS08-LMU03(T1), 54B- MS08-LMU03R(T1), 54- MS08-LMU03(T2), 54- MS08-LMU03R(T2)	(餘料)7, 7, 7, 7, 7	870.0		5	0	5	7@(4018)x1 7@(3142)x1 7@(2266)x1 7@(1390)x1 7@(514)x1

鋁材開料清單 X85897

窗號	編號(用料狀況)	實用長度(長料開數)	需要 支數	開料 支數	長料 支數	餘料 支數	編號(剩餘長度)
53B-MS03-LMU02(T1), 53B-MS03-LMU02(T2), 53B-MS03-LMU02R(T1), 53B-MS03-LMU02R(T2), 55B-MS09-LMU02, 55- MS09-LMU02, 56B-MS06- LMU02, 56B-MS06-LMU02R, 56-MS06-LMU02, 56-MS06- LMU02R	1-12	1060.0	60	45	12	0	1-4@(440)x4 5@(3638)x1 6@(4704)x1 7@(440)x1 8@(4704)x1 9@(1506)x1 10@(440)x1 11@(3638)x1 12@(440)x1
55B-MS09-LMU02R, 55- MS09-LMU02, 55-MS09- LMU02R, 56B-MS06-LMU02, 56B-MS06-LMU02R, 56- MS06-LMU02, 56-MS06- LMU02R	(餘料)5, 5-6, 6, 8-9, 11	1060.0		15	0	7	5@(1506)x1 5@(440)x1 6@(2572)x1 6@(440)x1 8-9@(440)x2 11@(440)x1
53-MS07-LMU02(T1), 54B- MS08-LMU02R(T1)	13-14	870.0	12	3	2	0	13@(4894)x1 14@(4018)x1
53-MS07-LMU02(T2), 53- MS07-LMU02R(T1), 53- MS07-LMU02R(T2), 54B- MS08-LMU02(T1), 54- MS08-LMU02(T2), 54- MS08-LMU02R(T2)	(餘料)13, 13, 13, 13- 14, 14	870.0		9	0	6	13@(4018)x1 13@(3142)x1 13@(2266)x1 13@(514)x1 14@(2266)x1 14@(514)x1

鋁材開料清單 X85896

窗號	編號(用料狀況)	實用長度(長料開數)	需要 支數	開料 支數	長料 支數	餘料 支數	編號(剩餘長度)
53B-MS03-LMU01(T1), 53B-MS03-LMU01(T2), 53B-MS03-LMU01R(T1), 53B-MS03-LMU01R(T2), 55B-MS09-LMU01, 55- MS09-LMU01, 56B-MS06- LMU01, 56B-MS06-LMU01R, 56-MS06-LMU01, 56-MS06- LMU01R	1-12	1060.0	60	45	12	0	1-4@(440)x4 5@(3638)x1 6@(4704)x1 7@(440)x1 8@(4704)x1 9@(1506)x1 10@(440)x1 11@(3638)x1 12@(440)x1
55B-MS09-LMU01R, 55- MS09-LMU01, 55-MS09- LMU01R, 56B-MS06-LMU01, 56B-MS06-LMU01R, 56- MS06-LMU01, 56-MS06- LMU01R	(餘料)5, 5-6, 6, 8-9, 11	1060.0		15	0	7	5@(1506)x1 5@(440)x1 6@(2572)x1 6@(440)x1 8-9@(440)x2 11@(440)x1
53-MS07-LMU01(T1), 54B- MS08-LMU01R(T1)	13-14	870.0	12	3	2	0	13@(4894)x1 14@(4018)x1
53-MS07-LMU01(T2), 53- MS07-LMU01R(T1), 53- MS07-LMU01R(T2), 54B- MS08-LMU01(T1), 54- MS08-LMU01(T2), 54- MS08-LMU01R(T2)	(餘料)13, 13, 13, 13- 14, 14	870.0		9	0	6	13@(4018)x1 13@(3142)x1 13@(2266)x1 13@(514)x1 14@(2266)x1 14@(514)x1

鋁材開料清單 X85895

窗號	編號(用料狀況)	實用長度(長料開數)	需要支數	開料支數	長料支數	餘料支數	編號(剩餘長度)
	1-20	1060.0	100	100	20	0	1-20@(440)x20
51B-MS01-LMU01(T1), 51B-MS01-LMU01(T2), 51B-MS01-LMU01R(T1), 51B-MS01-LMU01R(T2), 51B-MS01-LMU02(T1), 51B-MS01-LMU02(T2), 51B-MS01-LMU02R(T1), 51B-MS01-LMU02R(T2), 51B-MS01-LMU03(T1), 51B-MS01-LMU03(T2), 51B-MS01-LMU03R(T1), 51B-MS01-LMU03R(T2), 52B-MS02-LMU02(T1), 52B-MS02-LMU02(T2), 52B-MS02-LMU02R(T1), 52B-MS02-LMU02R(T2)							
51-MS01-LMU01(T1), 51-MS01-LMU02R(T1), 52A-MS05-LMU02(T1), 52A-MS05-LMU02R(T2), 51-MS01-LMU01(T2), 51-MS01-LMU01R(T1), 51-MS01-LMU01R(T2), 51-MS01-LMU02(T1), 51-MS01-LMU02(T2), 51-MS01-LMU02R(T2), 51-MS01-LMU03(T1), 51-MS01-LMU03(T2), 51-MS01-LMU03R(T1), 51-MS01-LMU03R(T2), 52A-MS05-LMU02(T2), 52A-MS05-LMU02R(T1)	21-24, 21, 21, 21, 21, 21-22, 22, 22, 22, 22- 23, 23	870.0	20	20	4	12	21-22@(4894)x2 23-24@(4018)x2 21@(4018)x1 21@(3142)x1 21@(2266)x1 21@(1390)x1 21@(514)x1 22@(4018)x1 22@(3142)x1 22@(2266)x1 22@(1390)x1 22@(514)x1 23@(2266)x1 23@(514)x1

鋁材開料總表

工程號碼: J852 工程名稱: MO4-T1T2座11F~23F攔河鋁料

序號	鋁料編號	名稱	表面處理		開料長度	實用長料總數量		浪費率(%)
			顏色	層厚		支數	長度	
1	X85895				5800	42	243600	8.46
2	X85896				5800	26	150800	7.85
3	X85897				5800	26	150800	7.85
4	X85898				5800	14	81200	12.84
5	X85899				5800	36	208800	9.63
6	X85900				5800	88	510400	2.22
7	X85901				5800	169	980200	1.89
8	X85902				5800	70	406000	2.15
9	X85903				5800	79	458200	7.79
10	X85904				5800	14	81200	12.84
11	X85905				5800	14	81200	12.84

送至: _____

由: _____

日期: _____

簡短說明: _____

共17頁 第1頁

打印日期: 23/2/2021 打印時間: 15:56

鋁材開料清單 X85905

窗號	編號(用料狀況)	實用長度(長料開數)	需要 支數	開料 支數	長料 支數	餘料 支數	編號(剩餘長度)
53B-MS03-LMU05(T1), 53B-MS03-LMU05(T2), 55B-MS09-LMU05R, 55- MS09-LMU05R, 56B-MS06- LMU05, 56B-MS06-LMU05R, 56-MS06-LMU05, 56-MS06- LMU05R, 57B-MS10-LMU05, 57-MS10-LMU05R, 53B- MS03-LMU05(T2), 55B- MS09-LMU05, 55B-MS09- LMU05R, 55-MS09-LMU05, 55-MS09-LMU05R, 56B- MS06-LMU05, 56B-MS06- LMU05R, 56-MS06-LMU05, 56-MS06-LMU05R, 57B- MS10-LMU05R, 57-MS10- LMU05	1-14, 3, 5, 5-6, 6-8, 10-11, 13, 13	1060.0	66	66	14	11	1-2@(440)x2 3@(4704)x1 4@(440)x1 5@(3638)x1 6@(4704)x1 7@(3638)x1 8@(1506)x1 9@(440)x1 10@(4704)x1 11@(2572)x1 12@(440)x1 13@(3638)x1 14@(4704)x1 3@(440)x1 5@(1506)x1 5@(440)x1 6@(1506)x1 6-8@(440)x3 10-11@(440)x2 13@(1506)x1 13@(440)x1

工程號碼: J852, 工程名稱: M04-T1T2座11F~23F攔河鋁料

開料長度: 5800, 總長料支數: 14, 總開料支數: 66

鋸片厚度(mm): 6, 料頭尾總切除(mm): 30, 浪費率(%): 12.84

鋁材開料清單 X85904

窗號	編號(用料狀況)	實用長度(長料開數)	需要 支數	開料 支數	長料 支數	餘料 支數	編號(剩餘長度)
53B-MS03-LMU04(T1), 53B-MS03-LMU04(T2), 55B-MS09-LMU04R, 55- MS09-LMU04R, 56B-MS06- LMU04, 56B-MS06-LMU04R, 56-MS06-LMU04, 56-MS06- LMU04R, 57B-MS10-LMU04, 57-MS10-LMU04R, 53B- MS03-LMU04(T2), 55B- MS09-LMU04, 55B-MS09- LMU04R, 55-MS09-LMU04, 55-MS09-LMU04R, 56B- MS06-LMU04, 56B-MS06- LMU04R, 56-MS06-LMU04, 56-MS06-LMU04R, 57B- MS10-LMU04R, 57-MS10- LMU04	1-14, 3, 5, 5-6, 6-8, 10-11, 13, 13	1060.0	66	66	14	11	1-2@(440)x2 3@(4704)x1 4@(440)x1 5@(3638)x1 6@(4704)x1 7@(3638)x1 8@(1506)x1 9@(440)x1 10@(4704)x1 11@(2572)x1 12@(440)x1 13@(3638)x1 14@(4704)x1 3@(440)x1 5@(1506)x1 5@(440)x1 6@(1506)x1 6-8@(440)x3 10-11@(440)x2 13@(1506)x1 13@(440)x1

鋁材開料清單 X85903

窗號	編號(用料狀況)	實用長度(長料開數)	需要支數	開料支數	長料支數	餘料支數	編號(剩餘長度)
52B-MS02-LMU01-1(T1), 52B-MS02-LMU01-1(T2), 52B-MS02-LMU01-2(T1), 52B-MS02-LMU01-2(T2)	1-31	1075.0	152	141	31	0	1-7@(365)x7 8@(4689)x1 9-15@(365)x7 16@(4689)x1 17-22@(365)x6 23@(3608)x1 24-30@(365)x7 31@(3608)x1
52B-MS02-LMU01-1(T2), 52B-MS02-LMU01-2(T1), 52B-MS02-LMU01-2(T2)	(餘料)8, 16, 23	1075.0		11	0	3	8@(365)x1 16@(365)x1 23@(365)x1
51B-MS01-LMU04(T1), 51B-MS01-LMU04(T2), 51B-MS01-LMU04R(T1), 51B-MS01-LMU04R(T2), 51B-MS01-LMU05(T1), 51B-MS01-LMU05(T2), 51B-MS01-LMU05R(T1), 51B-MS01-LMU05R(T2), 52B-MS02-LMU03(T1), 52B-MS02-LMU03(T2), 52B-MS02-LMU03R(T1), 52B-MS02-LMU03R(T2), 52B-MS02-LMU04(T1), 52B-MS02-LMU04(T2), 52B-MS02-LMU04R(T1), 52B-MS02-LMU04R(T2)	32-79	1060.0	240	207	48	0	32@(440)x1 33@(2572)x1 34@(440)x1 35@(1506)x1 36-39@(440)x4 40@(4704)x1 41@(440)x1 42@(3638)x1 43@(440)x1 44@(2572)x1 45@(440)x1 46@(1506)x1 47-51@(440)x5 52@(2572)x1 53-55@(440)x3 56@(2572)x1 57-59@(440)x3 60@(4704)x1 61-63@(440)x3 64@(4704)x1 65-66@(440)x2 67@(1506)x1 68-70@(440)x3 71@(1506)x1 72-74@(440)x3 75@(3638)x1 76-78@(440)x3 79@(3638)x1
51B-MS01-LMU04(T1), 51B-MS01-LMU04(T2), 51B-MS01-LMU04R(T1), 51B-MS01-LMU05(T1), 51B-MS01-LMU05(T2), 51B-MS01-LMU05R(T1), 51B-MS01-LMU05R(T2), 52B-MS02-LMU03(T2), 52B-MS02-LMU03R(T1), 52B-MS02-LMU03R(T2), 52B-MS02-LMU04(T1), 52B-MS02-LMU04(T2), 52B-MS02-LMU04R(T1), 52B-MS02-LMU04R(T2)	(餘料)31, 33, 35, 40, 42, 44, 46, 52, 56, 60, 64, 67, 71, 75	1060.0		33	0	14	31@(410)x1 33@(440)x1 35@(440)x1 40@(440)x1 42@(440)x1 44@(440)x1 46@(440)x1 52@(440)x1 56@(440)x1 60@(440)x1 64@(440)x1 67@(440)x1 71@(440)x1 75@(440)x1

鋁材開料清單 X85902

窗號	編號(用料狀況)	實用長度(長料開數)	需要支數	開料支數	長料支數	餘料支數	編號(剩餘長度)
52B-MS02-LTR04-A8(T1), 52B-MS02-LTR04-A8(T2)	1-19	2704.0	38	38	19	0	1-19@(350)x19
58-MS19-LTR01-A8	20	2384.0	2	1	1	0	20@(3380)x1
59A-MS22-LTR01-A8	(餘料)20	2384.0		1	0	1	20@(990)x1
55B-MS09-LTR15-A6(T1), 56B-MS06-LTR16-A8(T1)	21-25	2146.0	9	9	5	0	21-24@(1466)x4 25@(3618)x1
55B-MS09-LTR12-A6(T1), 56B-MS06-LTR13-A8(T1)	26-29	1946.0	9	7	4	0	26@(3818)x1 27-29@(1866)x3
55B-MS09-LTR12-A6(T1), 56B-MS06-LTR13-A8(T1)	(餘料)25-26	1946.0		2	0	2	25@(1666)x1 26@(1866)x1
55-MS09-LTR18-A6(T2), 56-MS06-LTR19-A8(T2)	30-36	1896.0	20	20	7	0	30-35@(64)x6 36@(1966)x1
55B-MS09-LTR14-A6(T1), 56B-MS06-LTR15-A8(T1)	(餘料)21-29	1270.0	9	9	0	9	21-24@(190)x4 25@(390)x1 26-29@(590)x4
55B-MS09-LTR02-A8(T1), 55-MS09-LTR02-A8(T2), 56B-MS06-LTR02-A8(T1), 56-MS06-LTR02-A8(T2), 57B-MS10-LTR02-A8(T1)	37-47	1249.0	44	33	11	0	37@(2005)x1 38@(750)x1 39@(4515)x1 40-41@(750)x2 42@(2005)x1 43-45@(750)x3 46-47@(4515)x2
55B-MS09-LTR02-A8(T1), 55-MS09-LTR02-A8(T2), 56B-MS06-LTR02-A8(T1), 56-MS06-LTR02-A8(T2), 57B-MS10-LTR02-A8(T1), 57-MS10-LTR02-A8(T2)	(餘料)36-37, 39, 42, 46-47	1249.0		11	0	6	36@(711)x1 37@(750)x1 39@(750)x1 42@(750)x1 46@(750)x1 47@(2005)x1
55B-MS09-LTR16-A6(T1), 56B-MS06-LTR17-A8(T1)	48-49	1206.0	9	5	2	0	48@(4558)x1 49@(922)x1
55B-MS09-LTR16-A6(T1), 56B-MS06-LTR17-A8(T1)	(餘料)47-48	1206.0		4	0	2	47@(793)x1 48@(922)x1
55-MS09-LTR17-A6(T2), 56-MS06-LTR18-A8(T2)	50-54	1168.0	20	18	5	0	50@(1074)x1 51@(3422)x1 52-54@(1074)x3
56-MS06-LTR18-A8(T2)	(餘料)51	1168.0		2	0	1	51@(1074)x1
55B-MS09-LTR13-A6(T1), 56B-MS06-LTR14-A8(T1)	55-57	1158.0	9	7	3	0	55@(3442)x1 56@(1114)x1 57@(4606)x1
56B-MS06-LTR14-A8(T1)	(餘料)55	1158.0		2	0	1	55@(1114)x1
55-MS09-LTR19-A6(T2), 56-MS06-LTR20-A8(T2)	58-61	1133.0	20	13	4	0	58@(3492)x1 59-60@(75)x2 61@(4631)x1
55-MS09-LTR19-A6(T2), 56-MS06-LTR20-A8(T2)	(餘料)57-58	1133.0		7	0	2	57@(50)x1 58@(75)x1
56B-MS06-LTR12-A8(T1)	62	1093.0	9	3	1	0	62@(2473)x1
55B-MS09-LTR11-A6(T1), 56B-MS06-LTR12-A8(T1)	(餘料)55-56, 61	1093.0		6	0	3	55-56@(15)x2 61@(235)x1
51B-MS01-LTR05-A8(T1), 51B-MS01-LTR05-A8(T2)	63-65	954.0	22	11	3	0	63@(2890)x1 64@(10)x1 65@(3850)x1
51B-MS01-LTR05-A8(T1), 51B-MS01-LTR05-A8(T2)	(餘料)20, 50-54, 62-63	954.0		11	0	8	20@(30)x1 50-54@(114)x5 62@(553)x1 63@(10)x1
51B-MS01-LTR06-A8-A8(T1), 51B-MS01-LTR06-A8-A8(T2)	66-68	894.0	22	15	3	0	66@(1270)x1 67@(370)x1 68@(2170)x1

工程號碼: J852, 工程名稱: M04-T1T2座11F~23F攔河鋁料
開料長度: 5800, 總長料支數: 70, 總開料支數: 340
鋸片厚度(mm): 6, 料頭尾總切除(mm): 30, 浪費率(%): 2.15

鋁材開料清單 X85902

窗號	編號(用料狀況)	實用長度(長料開數)	需要支數	開料支數	長料支數	餘料支數	編號(剩餘長度)
51B-MS01-LTR06-A8-A8(T1), 51B-MS01-LTR06-A8-A8(T2)	(餘料)48-49, 65-66	894.0		7	0	4	48-49@(22)x2 65@(250)x1 66@(370)x1
51B-MS01-LTR04-A8(T2)	69	594.0	22	7	1	0	69@(1570)x1
51B-MS01-LTR04-A8(T1), 51B-MS01-LTR04-A8(T2)	(餘料)36-47, 68	594.0		15	0	13	36@(111)x1 37-46@(150)x10 47@(193)x1 68@(370)x1
52B-MS02-LTR03R-A8(T2)	70	179.0	76	20	1	0	70@(2070)x1
52B-MS02-LTR03-A8(T1), 52B-MS02-LTR03-A8(T2), 52B-MS02-LTR03R-A8(T1)	(餘料)1-19, 21-29, 47, 61-62, 65-69	179.0		56	0	36	1-19@(165)x19 21-24@(5)x4 25@(20)x1 26-29@(35)x4 47@(8)x1 61@(50)x1 62@(183)x1 65@(65)x1 66-68@(0)x3 69@(90)x1

鋁材開料清單 X85901

窗號	編號(用料狀況)	實用長度(長料開數)	需要支數	開料支數	長料支數	餘料支數	編號(剩餘長度)
57B-MS10-LTR05-A7(T1), 57B-MS10-LTR13-A7(T1), 57B-MS10-LTR13-A8(T1)	1-6	3294.0	6	6	6	0	1-6@(2470)x6
57-MS10-LTR10-A7(T2), 57-MS10-LTR18-A7(T2), 57-MS10-LTR18-A8(T2)	7-9	3132.0	3	3	3	0	7-9@(2632)x3
52B-MS02-LTR02-A7(T1), 52B-MS02-LTR02-A7(T2), 52B-MS02-LTR04-A7(T1), 52B-MS02-LTR04-A7(T2)	10-47	2704.0	76	76	38	0	10-47@(350)x38
53B-MS03-LMU01-A7(T1), 53B-MS03-LMU01-A7(T2)	48-57	2569.0	22	19	10	0	48-56@(620)x9 57@(3195)x1
53B-MS03-LMU01-A7(T1)	(餘料)7-9	2569.0		3	0	3	7-9@(57)x3
58-MS19-LTR01-A7, 58- MS19-LTR01-A7(底), 59A-MS22-LTR01-A7, 59A- MS22-LTR01-A7(底)	(餘料)1-4	2384.0	4	4	0	4	1-4@(80)x4
55B-MS09-LTR15-A7(T1), 56B-MS06-LTR07-A7(T1), 56B-MS06-LTR16-A7(T1), 57B-MS10-LTR06-A7(T1), 57B-MS10-LTR14-A7(T1), 57B-MS10-LTR14-A8(T1)	58-68	2146.0	24	17	11	0	58@(3618)x1 59-64@(1466)x6 65-68@(3618)x4
55B-MS09-LTR07-A7(T1), 55B-MS09-LTR15-A7(T1), 56B-MS06-LTR07-A7(T1), 57B-MS10-LTR06-A7(T1), 57B-MS10-LTR14-A7(T1), 57B-MS10-LTR14-A8(T1)	(餘料)5-6, 57-58, 65-67	2146.0		7	0	7	5-6@(318)x2 57@(1043)x1 58@(1466)x1 65-67@(1466)x3
55B-MS09-LTR04-A7(T1), 55B-MS09-LTR12-A7(T1), 56B-MS06-LTR04-A7(T1), 56B-MS06-LTR13-A7(T1), 57B-MS10-LTR04-A7(T1), 57B-MS10-LTR12-A7(T1), 57B-MS10-LTR12-A8(T1)	69-80	1946.0	24	18	12	0	69-70@(3818)x2 71-76@(1866)x6 77-80@(3818)x4
55B-MS09-LTR04-A7(T1), 55B-MS09-LTR12-A7(T1), 56B-MS06-LTR04-A7(T1), 57B-MS10-LTR04-A7(T1), 57B-MS10-LTR12-A7(T1), 57B-MS10-LTR12-A8(T1)	(餘料)68-70, 77-79	1946.0		6	0	6	68@(1666)x1 69-70@(1866)x2 77-79@(1866)x3
55-MS09-LTR10-A7(T2), 55-MS09-LTR18-A7(T2), 56-MS06-LTR10-A7(T2), 56-MS06-LTR19-A7(T2), 57-MS10-LTR09-A7(T2), 57-MS10-LTR17-A7(T2), 57-MS10-LTR17-A8(T2)	81-97	1896.0	52	43	17	0	81@(64)x1 82@(3868)x1 83@(64)x1 84@(3868)x1 85-92@(64)x8 93@(1966)x1 94-95@(64)x2 96@(3868)x1 97@(1966)x1
55-MS09-LTR10-A7(T2), 55-MS09-LTR18-A7(T2), 56-MS06-LTR10-A7(T2), 57-MS10-LTR09-A7(T2), 57-MS10-LTR17-A8(T2)	(餘料)80, 82, 84, 93, 96	1896.0		9	0	5	80@(14)x1 82@(64)x1 84@(64)x1 93@(64)x1 96@(64)x1

鋁材開料清單 X85901

窗號	編號(用料狀況)	實用長度(長料開數)	需要支數	開料支數	長料支數	餘料支數	編號(剩餘長度)
55B-MS09-LTR06-A7(T1), 55B-MS09-LTR14-A7(T1), 56B-MS06-LTR06-A7(T1), 56B-MS06-LTR15-A7(T1)	(餘料)58-75	1270.0	18	18	0	18	58-67@(190)x10 68@(390)x1 69-75@(590)x7
55B-MS09-LTR02-A7(T1), 55-MS09-LTR01-A7(T2), 55-MS09-LTR02-A7(T2), 56B-MS06-LTR01-A7(T1), 56B-MS06-LTR02-A7(T1), 56-MS06-LTR01-A7(T2), 56-MS06-LTR02-A7(T2), 57B-MS10-LTR01-A7(T1), 57B-MS10-LTR02-A7(T1), 57-MS10-LTR01-A7(T2)	98-118	1249.0	88	66	21	0	98@(2005)x1 99@(750)x1 100@(4515)x1 101@(2005)x1 102-104@(750)x3 105@(4515)x1 106-107@(750)x2 108@(2005)x1 109-111@(750)x3 112@(4515)x1 113-114@(750)x2 115-117@(2005)x3 118@(4515)x1
55B-MS09-LTR01-A7(T1), 55B-MS09-LTR02-A7(T1), 55-MS09-LTR01-A7(T2), 55-MS09-LTR02-A7(T2), 56B-MS06-LTR01-A7(T1), 56B-MS06-LTR02-A7(T1), 56-MS06-LTR01-A7(T2), 56-MS06-LTR02-A7(T2), 57B-MS10-LTR01-A7(T1), 57B-MS10-LTR02-A7(T1), 57-MS10-LTR01-A7(T2), 57-MS10-LTR02-A7(T2)	(餘料)76-79, 97-98, 100-101, 105, 108, 112, 115-118	1249.0		22	0	15	76-79@(611)x4 97@(711)x1 98@(750)x1 100-101@(750)x2 105@(750)x1 108@(750)x1 112@(750)x1 115-117@(750)x3 118@(2005)x1
55B-MS09-LTR08-A7(T1), 56B-MS06-LTR08-A7(T1), 56B-MS06-LTR17-A7(T1), 57B-MS10-LTR15-A7(T1)	119-124	1206.0	24	13	6	0	119@(4558)x1 120@(922)x1 121@(3346)x1 122@(922)x1 123-124@(4558)x2
55B-MS09-LTR08-A7(T1), 55B-MS09-LTR16-A7(T1), 56B-MS06-LTR08-A7(T1), 56B-MS06-LTR17-A7(T1), 57B-MS10-LTR07-A7(T1), 57B-MS10-LTR15-A7(T1), 57B-MS10-LTR15-A8(T1)	(餘料)118-119, 119, 121, 123, 123-124	1206.0		11	0	7	118@(793)x1 119@(2134)x1 119@(922)x1 121@(922)x1 123@(2134)x1 123@(922)x1 124@(2134)x1
55-MS09-LTR09-A7(T2), 55-MS09-LTR17-A7(T2), 56-MS06-LTR09-A7(T2), 56-MS06-LTR18-A7(T2), 57-MS10-LTR08-A7(T3), 57-MS10-LTR16-A8(T3)	125-136	1168.0	46	34	12	0	125@(1074)x1 126@(4596)x1 127@(2248)x1 128-130@(1074)x3 131@(4596)x1 132-133@(1074)x2 134@(2248)x1 135-136@(4596)x2
55-MS09-LTR09-A7(T2), 55-MS09-LTR17-A7(T2), 56-MS06-LTR09-A7(T2), 56-MS06-LTR18-A7(T2), 57-MS10-LTR08-A7(T3), 57-MS10-LTR16-A7(T3), 57-MS10-LTR16-A8(T3)	(餘料)124, 126-127, 131, 134-135, 135	1168.0		12	0	7	124@(960)x1 126-127@(1074)x2 131@(1074)x1 134@(1074)x1 135@(2248)x1 135@(1074)x1
55B-MS09-LTR13-A7(T1), 56B-MS06-LTR05-A7(T1), 56B-MS06-LTR14-A7(T1)	137-140	1158.0	18	12	4	0	137@(4606)x1 138-139@(1114)x2 140@(2278)x1

鋁材開料清單 X85901

窗號	編號(用料狀況)	實用長度(長料開數)	需要支數	開料支數	長料支數	餘料支數	編號(剩餘長度)
55B-MS09-LTR05-A7(T1), 55B-MS09-LTR13-A7(T1), 56B-MS06-LTR05-A7(T1)	(餘料)136, 136-137	1158.0		6	0	3	136@(2268)x1 136@(1104)x1 137@(1114)x1
55-MS09-LTR11-A7(T2), 55-MS09-LTR19-A7(T2), 56-MS06-LTR11-A7(T2), 56-MS06-LTR20-A7(T2)	141-148	1133.0	40	36	8	0	141@(1214)x1 142-144@(75)x3 145@(1214)x1 146-147@(75)x2 148@(2353)x1
55-MS09-LTR11-A7(T2), 55-MS09-LTR19-A7(T2), 56-MS06-LTR20-A7(T2)	(餘料)140-141, 145	1133.0		4	0	3	140@(0)x1 141@(75)x1 145@(75)x1
56B-MS06-LTR03-A7(T1), 56B-MS06-LTR12-A7(T1), 57B-MS10-LTR11-A7(T1)	149-152	1093.0	24	13	4	0	149-150@(275)x2 151@(3572)x1 152@(4671)x1
55B-MS09-LTR03-A7(T1), 55B-MS09-LTR11-A7(T1), 56B-MS06-LTR03-A7(T1), 57B-MS10-LTR03-A7(T1), 57B-MS10-LTR11-A7(T1), 57B-MS10-LTR11-A8(T1)	(餘料)136-139, 148, 151, 151-152	1093.0		11	0	8	136@(5)x1 137-139@(15)x3 148@(155)x1 151@(1374)x1 151@(275)x1 152@(2473)x1
51B-MS01-LTR02-A7(T2), 51B-MS01-LTR05-A7(T1), 51B-MS01-LTR05-A7(T2)	153-157	954.0	44	24	5	0	153@(10)x1 154@(4810)x1 155-156@(10)x2 157@(970)x1
51B-MS01-LTR02-A7(T1), 51B-MS01-LTR02-A7(T2), 51B-MS01-LTR05-A7(T1)	(餘料)57, 124-135, 152, 154	954.0		20	0	15	57@(83)x1 124@(0)x1 125-135@(114)x11 152@(553)x1 154@(10)x1
51B-MS01-LTR03-A7(T1), 51B-MS01-LTR03-A7(T2), 51B-MS01-LTR06-A7(T1), 51B-MS01-LTR06-A7(T2)	158-164	894.0	44	32	7	0	158@(1270)x1 159@(370)x1 160@(2170)x1 161@(370)x1 162@(3070)x1 163@(370)x1 164@(3970)x1
51B-MS01-LTR03-A7(T1), 51B-MS01-LTR03-A7(T2), 51B-MS01-LTR06-A7(T1), 51B-MS01-LTR06-A7(T2)	(餘料)119-123, 157-158, 160, 162	894.0		12	0	9	119-123@(22)x5 157@(70)x1 158@(370)x1 160@(370)x1 162@(370)x1
51B-MS01-LTR04-A7(T2)	165	594.0	44	3	1	0	165@(3970)x1
51B-MS01-LTR01-A7(T1), 51B-MS01-LTR01-A7(T2), 51B-MS01-LTR04-A7(T1), 51B-MS01-LTR04-A7(T2)	(餘料)48-56, 76-79, 97- 118, 164	594.0		41	0	36	48-56@(20)x9 76-79@(11)x4 97@(111)x1 98-117@(150)x20 118@(193)x1 164@(370)x1
5B3-MS03-LMU02-A7(T2)	166	544.0	22	7	1	0	166@(1920)x1
53B-MS03-LMU02-A7(T1), 5B3-MS03-LMU02-A7(T2)	(餘料)69-75, 152, 165, 165	544.0		15	0	10	69-75@(40)x7 152@(3)x1 165@(2320)x1 165@(120)x1
52B-MS02-LTR03-A7(T1), 52B-MS02-LTR03-A7(T2), 52B-MS02-LTR03R-A7(T2)	167-169	179.0	152	27	3	0	167@(3180)x1 168@(5215)x1 169@(3920)x1

工程號碼: J852, 工程名稱: M04-T1T2座11F~23F攔河鋁料
開料長度: 5800, 總長料支數: 169, 總開料支數: 775
鋸片厚度(mm): 6, 料頭尾總切除(mm): 30, 浪費率(%): 1.89

鋁材開料清單 X85901

窗號	編號(用料狀況)	實用長度(長料開數)	需要支數	開料支數	長料支數	餘料支數	編號(剩餘長度)
52B-MS02-LTR01-A7(T1), 52B-MS02-LTR01-A7(T2), 52B-MS02-LTR01R-A7(T1), 52B-MS02-LTR01R-A7(T2), 52B-MS02-LTR03-A7(T1), 52B-MS02-LTR03-A7(T2), 52B-MS02-LTR03R-A7(T1), 52B-MS02-LTR03R-A7(T2)	(餘料)5-6, 10-47, 58-68, 118, 149-151, 158-164, 166, 166-168, 168	179.0		125	0	67	5-6@(133)x2 10-47@(165)x38 58-67@(5)x10 68@(20)x1 118@(8)x1 149-151@(90)x3 158-164@(0)x7 166@(810)x1 166@(70)x1 167@(35)x1 168@(1885)x1 168@(35)x1

鋁材開料清單 X85900

窗號	編號(用料狀況)	實用長度(長料開數)	需要支數	開料支數	長料支數	餘料支數	編號(剩餘長度)
57B-MS10-LTR05-A6(T1)	1-2	3294.0	2	2	2	0	1-2@(2470)x2
57-MS10-LTR10-A6(T2)	3	3132.0	1	1	1	0	3@(2632)x1
52B-MS02-LTR02-A6(T1), 52B-MS02-LTR02-A6(T2)	4-22	2704.0	38	38	19	0	4-22@(350)x19
53B-MS03-LMU01-A6(T1), 53B-MS03-LMU01-A6(T2)	23-33	2569.0	22	21	11	0	23-32@(620)x10 33@(3195)x1
53B-MS03-LMU01-A6(T1)	(餘料)3	2569.0		1	0	1	3@(57)x1
58-MS19-LTR01-A6, 59A- MS22-LTR01-A6	(餘料)1-2	2384.0	2	2	0	2	1-2@(80)x2
55B-MS09-LTR07-A6(T1), 56B-MS06-LTR07-A6(T1), 57B-MS10-LTR06-A6(T1)	34-38	2146.0	11	9	5	0	34@(3618)x1 35-38@(1466)x4
55B-MS09-LTR07-A6(T1), 56B-MS06-LTR07-A6(T1)	(餘料)33-34	2146.0		2	0	2	33@(1043)x1 34@(1466)x1
55B-MS09-LTR04-A6(T1), 56B-MS06-LTR04-A6(T1), 57B-MS10-LTR04-A6(T1)	39-44	1946.0	11	10	6	0	39-42@(1866)x4 43-44@(3818)x2
57B-MS10-LTR04-A6(T1)	(餘料)43	1946.0		1	0	1	43@(1866)x1
55-MS09-LTR10-A6(T2), 56-MS06-LTR10-A6(T2), 57-MS10-LTR09-A6(T2)	45-52	1896.0	24	20	8	0	45@(64)x1 46@(3868)x1 47-51@(64)x5 52@(3868)x1
55-MS09-LTR10-A6(T2), 56-MS06-LTR10-A6(T2)	(餘料)44, 46	1896.0		4	0	2	44@(14)x1 46@(64)x1
55B-MS09-LTR06-A6(T1), 56B-MS06-LTR06-A6(T1)	(餘料)34-42	1270.0	9	9	0	9	34-38@(190)x5 39-42@(590)x4
55-MS09-LTR01-A6(T2), 56B-MS06-LTR01-A6(T1), 56-MS06-LTR01-A6(T2), 57B-MS10-LTR01-A6(T1)	53-62	1249.0	44	34	10	0	53@(750)x1 54@(3260)x1 55-60@(750)x6 61-62@(3260)x2
55B-MS09-LTR01-A6(T1), 56B-MS06-LTR01-A6(T1), 57B-MS10-LTR01-A6(T1), 57-MS10-LTR01-A6(T2)	(餘料)43, 52, 54, 61-62	1249.0		10	0	5	43@(611)x1 52@(103)x1 54@(750)x1 61-62@(750)x2
55B-MS09-LTR08-A6(T1), 56B-MS06-LTR08-A6(T1)	63-65	1206.0	11	7	3	0	63@(3346)x1 64@(922)x1 65@(4558)x1
56B-MS06-LTR08-A6(T1), 57B-MS10-LTR07-A6(T1)	(餘料)63, 65	1206.0		4	0	2	63@(922)x1 65@(2134)x1
55-MS09-LTR09-A6(T2), 56-MS06-LTR09-A6(T2), 57-MS10-LTR08-A6(T3)	66-71	1168.0	22	17	6	0	66@(1074)x1 67@(4596)x1 68-69@(1074)x2 70@(2248)x1 71@(4596)x1
55-MS09-LTR09-A6(T2), 56-MS06-LTR09-A6(T2), 57-MS10-LTR08-A6(T3)	(餘料)65, 67, 70	1168.0		5	0	3	65@(960)x1 67@(1074)x1 70@(1074)x1
56B-MS06-LTR05-A6(T1)	72-73	1158.0	9	6	2	0	72@(1114)x1 73@(3442)x1
55B-MS09-LTR05-A6(T1), 56B-MS06-LTR05-A6(T1)	(餘料)71, 71	1158.0		3	0	2	71@(2268)x1 71@(1104)x1
55-MS09-LTR11-A6(T2), 56-MS06-LTR11-A6(T2)	74-77	1133.0	20	15	4	0	74@(2353)x1 75-76@(75)x2 77@(3492)x1
55-MS09-LTR11-A6(T2), 56-MS06-LTR11-A6(T2)	(餘料)73-74	1133.0		5	0	2	73@(25)x1 74@(75)x1
56B-MS06-LTR03-A6(T1), 57B-MS10-LTR03-A6(T1)	78-79	1093.0	11	5	2	0	78@(1374)x1 79@(4671)x1

鋁材開料清單 X85900

窗號	編號(用料狀況)	實用長度(長料開數)	需要支數	開料支數	長料支數	餘料支數	編號(剩餘長度)
55B-MS09-LTR03-A6(T1), 56B-MS06-LTR03-A6(T1), 57B-MS10-LTR03-A6(T1)	(餘料)71-72, 77-78	1093.0		6	0	4	71@(5)x1 72@(15)x1 77@(195)x1 78@(275)x1
51B-MS01-LTR02-A6(T2)	80-81	954.0	22	11	2	0	80@(10)x1 81@(970)x1
51B-MS01-LTR02-A6(T1)	(餘料)33, 65-70, 79	954.0		11	0	8	33@(83)x1 65@(0)x1 66-70@(114)x5 79@(831)x1
51B-MS01-LTR03-A6(T1), 51B-MS01-LTR03-A6(T2)	82-85	894.0	22	15	4	0	82@(370)x1 83@(3970)x1 84@(370)x1 85@(4870)x1
51B-MS01-LTR03-A6(T1), 51B-MS01-LTR03-A6(T2)	(餘料)63-64, 81, 83	894.0		7	0	4	63-64@(22)x2 81@(70)x1 83@(370)x1
51B-MS01-LTR01-A6(T1), 51B-MS01-LTR01-A6(T2)	(餘料)23-32, 43, 53-62, 79	594.0	22	22	0	22	23-32@(20)x10 43@(11)x1 53-62@(150)x10 79@(231)x1
53B-MS03-LMU02-A6(T2)	86	544.0	22	10	1	0	86@(270)x1
53B-MS03-LMU02-A6(T1), 53B-MS03-LMU02-A6(T2)	(餘料)39-42, 85, 85	544.0		12	0	6	39-42@(40)x4 85@(1020)x1 85@(470)x1
52B-MS02-LTR01-A6(T2), 52B-MS02-LTR01R-A6(T2)	87-88	179.0	76	11	2	0	87@(5400)x1 88@(4105)x1
52B-MS02-LTR01-A6(T1), 52B-MS02-LTR01-A6(T2), 52B-MS02-LTR01R-A6(T1), 52B-MS02-LTR01R-A6(T2)	(餘料)4-22, 34-38, 77- 79, 82-87, 87	179.0		65	0	34	4-22@(165)x19 34-38@(5)x5 77@(10)x1 78@(90)x1 79@(46)x1 82-84@(0)x3 85@(100)x1 86@(85)x1 87@(2070)x1 87@(35)x1

鋁材開料清單 X85899

窗號	編號(用料狀況)	實用長度(長料開數)	需要 支數	開料 支數	長料 支數	餘料 支數	編號(剩餘長度)
55B-MS09-LMU06, 55B-MS09-LMU07, 55-MS09-LMU06, 55-MS09-LMU07, 56B-MS06-LMU06, 56B-MS06-LMU07, 56-MS06-LMU06, 56-MS06-LMU07, 57B-MS10-LMU06, 57B-MS10-LMU07, 57-MS10-LMU06, 57-MS10-LMU07, 55B-MS09-LMU07, 55-MS09-LMU06, 55-MS09-LMU07, 56B-MS06-LMU07, 56-MS06-LMU06, 56-MS06-LMU07, 57B-MS10-LMU06, 57-MS10-LMU06, 57-MS10-LMU07	1-36, 2, 4, 6, 14, 20, 25, 31, 34-35	1060.0	176	176	36	9	1@(440)x1 2@(2572)x1 3@(440)x1 4@(4704)x1 5@(440)x1 6@(2572)x1 7-13@(440)x7 14@(2572)x1 15-19@(440)x5 20@(4704)x1 21-24@(440)x4 25@(1506)x1 26-30@(440)x5 31@(3638)x1 32-33@(440)x2 34@(2572)x1 35@(3638)x1 36@(4704)x1 2@(440)x1 4@(440)x1 6@(440)x1 14@(440)x1 20@(440)x1 25@(440)x1 31@(440)x1 34-35@(440)x2

工程號碼: J852, 工程名稱: M04-T1T2座11F~23F攔河鋁料

開料長度: 5800, 總長料支數: 14, 總開料支數: 66

鋸片厚度(mm): 6, 料頭尾總切除(mm): 30, 浪費率(%): 12.84

鋁材開料清單 X85898

窗號	編號(用料狀況)	實用長度(長料開數)	需要 支數	開料 支數	長料 支數	餘料 支數	編號(剩餘長度)
53B-MS03-LMU03(T1), 53B-MS03-LMU03(T2), 55B-MS09-LMU03R, 55- MS09-LMU03R, 56B-MS06- LMU03, 56B-MS06-LMU03R, 56-MS06-LMU03, 56-MS06- LMU03R, 57B-MS10-LMU03, 57-MS10-LMU03R, 53B- MS03-LMU03(T2), 55B- MS09-LMU03, 55B-MS09- LMU03R, 55-MS09-LMU03, 55-MS09-LMU03R, 56B- MS06-LMU03, 56B-MS06- LMU03R, 56-MS06-LMU03, 56-MS06-LMU03R, 57B- MS10-LMU03R, 57-MS10- LMU03	1-14, 3, 5, 5-6, 6-8, 10-11, 13, 13	1060.0	66	66	14	11	1-2@(440)x2 3@(4704)x1 4@(440)x1 5@(3638)x1 6@(4704)x1 7@(3638)x1 8@(1506)x1 9@(440)x1 10@(4704)x1 11@(2572)x1 12@(440)x1 13@(3638)x1 14@(4704)x1 3@(440)x1 5@(1506)x1 5@(440)x1 6@(1506)x1 6-8@(440)x3 10-11@(440)x2 13@(1506)x1 13@(440)x1

鋁材開料清單 X85897

窗號	編號(用料狀況)	實用長度(長料開數)	需要 支數	開料 支數	長料 支數	餘料 支數	編號(剩餘長度)
53B-MS03-LMU02(T1), 53B-MS03-LMU02(T2), 53B-MS03-LMU02R(T1), 53B-MS03-LMU02R(T2), 55B-MS09-LMU02, 55B- MS09-LMU02R, 55-MS09- LMU02, 55-MS09-LMU02R, 56B-MS06-LMU02, 56B- MS06-LMU02R, 56-MS06- LMU02, 56-MS06-LMU02R, 57B-MS10-LMU02, 57- MS10-LMU02R, 53B-MS03- LMU02(T2), 53B-MS03- LMU02R(T1), 53B-MS03- LMU02R(T2), 55B-MS09- LMU02, 55B-MS09-LMU02R, 55-MS09-LMU02, 55-MS09- LMU02R, 56B-MS06-LMU02, 56B-MS06-LMU02R, 56- MS06-LMU02, 56-MS06- LMU02R, 57B-MS10- LMU02R, 57-MS10-LMU02	1-26, 3, 5, 7, 9-13, 16, 19, 22, 25, 25	1060.0	126	126	26	13	1-2@(440)x2 3@(4704)x1 4@(440)x1 5@(3638)x1 6@(440)x1 7@(2572)x1 8@(440)x1 9@(1506)x1 10@(2572)x1 11@(3638)x1 12@(2572)x1 13@(1506)x1 14-15@(440)x2 16@(2572)x1 17-18@(440)x2 19@(3638)x1 20-21@(440)x2 22@(4704)x1 23-24@(440)x2 25@(3638)x1 26@(4704)x1 3@(440)x1 5@(440)x1 7@(440)x1 9-13@(440)x5 16@(440)x1 19@(440)x1 22@(440)x1 25@(1506)x1 25@(4704)x1
58-MS19-LMU02, 58-MS19- LMU02R, 59A-MS22-LMU02, 59A-MS22-LMU02R	(餘料)26, 26, 26, 26	960.0	4	4	0	4	26@(3738)x1 26@(2772)x1 26@(1806)x1 26@(840)x1

鋁材開料清單 X85896

窗號	編號(用料狀況)	實用長度(長料開數)	需要 支數	開料 支數	長料 支數	餘料 支數	編號(剩餘長度)
53B-MS03-LMU01(T1), 53B-MS03-LMU01(T2), 53B-MS03-LMU01R(T1), 53B-MS03-LMU01R(T2), 55B-MS09-LMU01, 55B- MS09-LMU01R, 55-MS09- LMU01, 55-MS09-LMU01R, 56B-MS06-LMU01, 56B- MS06-LMU01R, 56-MS06- LMU01, 56-MS06-LMU01R, 57B-MS10-LMU01, 57- MS10-LMU01R, 53B-MS03- LMU01(T2), 53B-MS03- LMU01R(T1), 53B-MS03- LMU01R(T2), 55B-MS09- LMU01, 55B-MS09-LMU01R, 55-MS09-LMU01, 55-MS09- LMU01R, 56B-MS06-LMU01, 56B-MS06-LMU01R, 56- MS06-LMU01, 56-MS06- LMU01R, 57B-MS10- LMU01R, 57-MS10-LMU01	1-26, 3, 5, 7, 9-13, 16, 19, 22, 25, 25	1060.0	126	126	26	13	1-2@(440)x2 3@(4704)x1 4@(440)x1 5@(3638)x1 6@(440)x1 7@(2572)x1 8@(440)x1 9@(1506)x1 10@(2572)x1 11@(3638)x1 12@(2572)x1 13@(1506)x1 14-15@(440)x2 16@(2572)x1 17-18@(440)x2 19@(3638)x1 20-21@(440)x2 22@(4704)x1 23-24@(440)x2 25@(3638)x1 26@(4704)x1 3@(440)x1 5@(440)x1 7@(440)x1 9-13@(440)x5 16@(440)x1 19@(440)x1 22@(440)x1 25@(1506)x1 25@(4704)x1
58-MS19-LMU01, 58-MS19- LMU01R, 59A-MS22-LMU01, 59A-MS22-LMU01R	(餘料)26, 26, 26, 26	960.0	4	4	0	4	26@(3738)x1 26@(2772)x1 26@(1806)x1 26@(840)x1

鋁材開料清單 X85895

窗號	編號(用料狀況)	實用長度(長料開數)	需要支數	開料支數	長料支數	餘料支數	編號(剩餘長度)
51B-MS01-LMU01(T1), 51B-MS01-LMU01(T2), 51B-MS01-LMU01R(T1), 51B-MS01-LMU01R(T2), 51B-MS01-LMU02(T1), 51B-MS01-LMU02(T2), 51B-MS01-LMU02R(T1), 51B-MS01-LMU02R(T2), 51B-MS01-LMU03(T1), 51B-MS01-LMU03(T2), 51B-MS01-LMU03R(T1), 51B-MS01-LMU03R(T2), 52B-MS02-LMU02(T1), 52B-MS02-LMU02(T2), 52B-MS02-LMU02R(T1), 52B-MS02-LMU02R(T2), 51B-MS01-LMU01(T2), 51B-MS01-LMU01R(T1), 51B-MS01-LMU01R(T2), 51B-MS01-LMU02(T1), 51B-MS01-LMU02R(T1), 51B-MS01-LMU02R(T2), 51B-MS01-LMU03(T1), 51B-MS01-LMU03(T2), 51B-MS01-LMU03R(T2), 52B-MS02-LMU02(T1), 52B-MS02-LMU02R(T2)	1-42, 3, 5, 7, 9, 14, 16, 18, 20, 25, 27, 38	1060.0	208	208	42	11	1-2@(440)x2 3@(4704)x1 4@(440)x1 5@(3638)x1 6@(440)x1 7@(2572)x1 8@(440)x1 9@(1506)x1 10-13@(440)x4 14@(4704)x1 15@(440)x1 16@(3638)x1 17@(440)x1 18@(2572)x1 19@(440)x1 20@(1506)x1 21-24@(440)x4 25@(4704)x1 26@(440)x1 27@(3638)x1 28-37@(440)x10 38@(2572)x1 39-41@(440)x3 42@(2572)x1 3@(440)x1 5@(440)x1 7@(440)x1 9@(440)x1 14@(440)x1