

工程指示 / 要求簡箋(E.I.)

工程指示編號：EI / 2948 / 21 修改版次：-
 工程編號 : J - 852 工程名稱 : 亞皆老街中電
 工程項目 : 後裝門窗 防水物料(HLM5000)(碰 stone cladding 用)
 收件人 : Maggie / 林哥 發件人 : Ant Yeung 日期 : 14/01/2021

要求提供 / 確認 事項 :

- | | | |
|-------------------------------------|-------------------------------------|-------------------------------|
| <input type="checkbox"/> 初步鋁料 B.M. | <input type="checkbox"/> 加工拆圖，然後生產 | <input type="checkbox"/> 尺寸表 |
| <input type="checkbox"/> 正式鋁料 B.M. | <input type="checkbox"/> 技術上資料 / 指示 | <input type="checkbox"/> 報價 |
| <input type="checkbox"/> 配件 B.M. | <input type="checkbox"/> 樣辦或貨品說明書 | <input type="checkbox"/> 分判合約 |
| <input type="checkbox"/> 其他 : _____ | | |

內容 :

請按 BM 訂購 HLM5000 送地盤使用

按合約要求，汶泥碰 cladding 位置防水物料需使用 HLM5000

供應商: Sanfield, 聯絡人: 梁生, 2833 6828

謝謝。

請在 2021.01.19 前完成上列要求。

附: 0 頁

以上項目為:

- 原合約工程包 原合約工程加 / 減賬 新工程報價

原因 :- _____

分發東莞各部門 :

- | | | | |
|--|---|--|---|
| <input type="checkbox"/> 生產技術總監 <input type="checkbox"/> 連附件 | <input type="checkbox"/> 技術部 <input type="checkbox"/> 連附件 | <input type="checkbox"/> 生產部 <input type="checkbox"/> 連附件 | <input type="checkbox"/> 機械設計部 <input type="checkbox"/> 連附件 |
| <input type="checkbox"/> 採購部 <input type="checkbox"/> 連附件 | <input type="checkbox"/> 生產統籌部 <input type="checkbox"/> 連附件 | <input type="checkbox"/> 小羅 & 清 <input type="checkbox"/> 連附件 | |
| <input type="checkbox"/> 質檢部 <input type="checkbox"/> 連附件 | <input type="checkbox"/> 會計部 <input type="checkbox"/> 連附件 | <input type="checkbox"/> 報關組 <input type="checkbox"/> 連附件 | <input type="checkbox"/> 其他 <u>楊榮輝</u> <input type="checkbox"/> 連附件 |

分發其他分判 :

- (v) 水洪 連附件

分發香港各部門 :

- | | | | |
|--|--|--|---|
| <input type="checkbox"/> 行政部 <input type="checkbox"/> 連附件 | <input type="checkbox"/> 會計部 <input type="checkbox"/> 連附件 | <input checked="" type="checkbox"/> 統籌部 <input type="checkbox"/> 連附件 | <input type="checkbox"/> 工程部地盤科文 <input type="checkbox"/> 連附件 <u>祥哥</u> |
| <input checked="" type="checkbox"/> 採購部 <input type="checkbox"/> 連附件 | <input type="checkbox"/> QS 部 <input type="checkbox"/> 連附件 | <input type="checkbox"/> 維修部 <input type="checkbox"/> 連附件 | <input type="checkbox"/> 其他 _____ <input type="checkbox"/> 連附件 |

傳遞編號 :

HK / 21

發件人簽署 :

項目經理簽署 :

 美特鋁質有限公司 MIDI Aluminium Fabricator Ltd.		工程號: J852		計算:	CJM	日期:	2020.08.12	送呈:		
		地盤名稱: 亞皆老街							核對:	wsh
幕牆廠用配件B.M.表		項目類別: 幕牆 (1F~23F)		批准:		日期:		此BM(依據施工圖)來計算		
BM編號:		A/C Code:		修改說明:						
序號	修改標示	配件圖號	物料編號	配件名稱	顏色	實用	後備	總數	單位	備注
1	安送	1/3		HLM5000		54	3	57	桶	
							合計:	57		

$$IW + FD = 1078 \text{ 米}$$

$$CW(FD) = 330$$

$$SD = 2926 \text{ 米}$$

$$\rightarrow 4334 \text{ 米}$$

① Bon d'crete (20 公斤/桶)

$$4334 \times 0.0125 \div 20 = 2.7 \text{ 桶}$$

② HB 40

按 1327 米

3 1327 米用 2066 包

4334 米用 285 包

~~③ 防水油 (23L, 1桶)~~
~~Paulotak~~

~~$$4334 \times 0.15 \div 23L = 28.2 \text{ 桶}$$~~

③ 防水油 HLM 5000 (每桶可涂 $12m^2$)
($4334 \times 0.15 \div 12$)

$$= 54 \text{ 桶}$$

Sk-01

SK-01

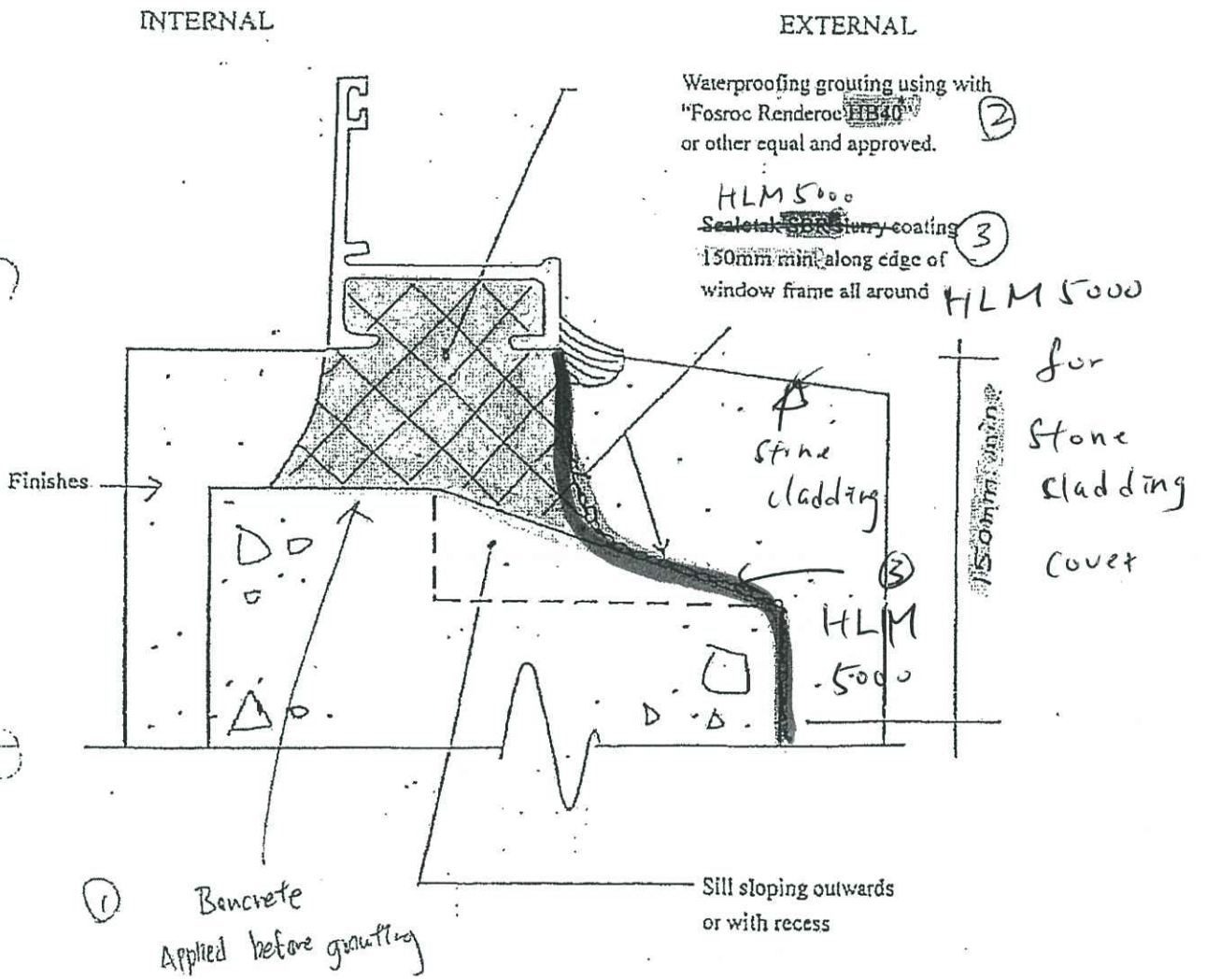

Waterproofing Coating and Window Frame Grouting

Details 17A (Rev. 2)

Item	Elements	Requirements	Document Referred To
9.	Window Frame Grouting & Coating	<p>Fosroc Renderoc HB40 or other equal and approved shall be used as the frame grouting material.</p> <p>Sealotak SBR slurry coating shall be applied for a coverage min. 150mm along edge of window frame all around for external finishes using tiles. HLM5000 or equal shall be used instead for external cladding.</p>	Waterproofing System Specification revised May 2019
10	Not Used		
11.	Heat Soak Test for Tempered Glass	<p>All tempered glass pane should be heat soak treated as required by latest BD regulation/Practice Notes for curtain wall, window, window wall systems and glass protective barriers and etc. where the duration of the holding phase is 2 hours minimum. The surface temperature of the glass panes shall be maintained in the range of 290°C±10°C during the holding phase.</p> <p>The contractor shall provide the Employer full set tape recording records showing the whole heat soak test process and the monitoring record of oven temperature.</p> <p>These tempered glass supplied to site must be accompanied with proper certificate of heat soak test.</p>	Practice Note 016 (7 th Revision)
12-22	Not Used		
23.	Quality Control System of Precast Façade Production	<p>The façade factory must be ISO9000 certified with pre-production assessment by developer's PM, QM & RSE.</p> <p>Trial panels shall be produced before mass production.</p> <p>Concrete supplier must be QSPSC certified. 28-day cube test by HOKLAS laboratory in China & 16-hour cube test for demoulding by factory's in-house laboratory.</p> <p>Steel reinforcement must be provided with delivery schedule, mill certificate and identification document. Tests by HOKLAS laboratory.</p> <p>A production manager and a full-time QCE from the façade factory, a full-time engineer from the main contractor, and a full-time RE from consultant shall be arranged in façade factory for daily supervision.</p> <p>Pull out test: pull-out test for external wall tile on façade unit at 28 days after the application. 1 set (3 nos.) per six storey of façade.</p> <p>Water test for window frame: 100% water test (unpressurized water flow) for edge around window frame before tiling (at a rate of 2m per minute to entire length of grouted joints).</p>	Technical Info. T033B
24-31	Not Use		

Sonneborn®
Waterproofing
Systems



SONOSHIELD®

HLM 5000®

Liquid cold-applied elastomeric waterproofing
membrane system



Where to Use HLM 5000®

- Above grade between two-course concrete and within cavity walls
- Exterior below grade on masonry, concrete, and incidental metal
- Parking garages
- Plaza decks and malls
- Fountains and pools
- Balconies and planters
- Bridges and highways
- Below-grade slabs
- Walls and culverts
- Sea walls, dams and reservoirs
- Concrete tanks
- Exterior plywood

Features

- Standard and high-build systems...
- Waterproofs concrete...
- Elastomeric...
- Wide service temperature range...
- Chemical resistant...
- Seamless cold-applied membrane...
- Asphalt-modified polyurethane...
- May be applied to green concrete with appropriate primer...

Benefits

- Specification versatility and extended warranty
- Protects structure from water penetration
- Permits expansion and contraction
- Suitable for all climates
- Resists bacterial attack, and many acids, alkalis, and salts
- Eliminates lapping, seaming, and precutting
- No hot-melt equipment required
- Ideal for fast track projects

How to Apply HLM 5000®

Surface Preparation

1 For best results, all concrete deck surfaces should be lightly steel troweled to a flat, uniform surface. A light broom finish is acceptable. New concrete must be properly water cured at least 14 days. Membrane curing compounds must be mechanically removed. For extremely porous block, a parge coat of Sonoblock™ (see Form No. 1017972) may be required, or prime with a coat of HLM 5000® diluted up to 25% with Sonneborn Reducer 990. Apply Sonoblock™ at the rate of approximately 400 sq. ft. (37.2 m²) per bag for the parge coat. Allow to cure a minimum of 7 days before applying HLM 5000®.

2 Remove dust, dirt, and other contaminants just before or during application. Surfaces must be dry at the time of application.

3 Air void pockmarks or honeycombs must be opened up to allow HLM 5000® to fill the cavities completely. Air entrapment within voids may cause blisters. Extreme cases may require a parge coat.

4 **Prestripping:** Before applying the final membrane, all joints, cracks, and openings around protrusions must be sealed by caulking or prestripping (a preliminary coating of HLM 5000® applied with a trowel or stiff bristle brush). Allow to dry overnight before applying final membrane.

When the final membrane is applied, the overall thickness over joints and cracks, at coves, and around penetrations should be approximately 100 wet mils (2.5 mm) on the standard system.

5 **Static joints and cracks:** Joints and cracks less than 1/16" (1.6 mm) should be filled by prestripping. Apply material so it both fills and overlaps the joint or crack to a width of 4" (102 mm) on each side.

6 **Working or expansion joints:** All joints over 1/8" (3 mm) must be sealed with a Sonolastic® sealant. Any **working joint** less than 1/8" (3 mm) should be routed to a minimum of 1/8" (3 mm) and filled with a Sonolastic® sealant. Prevent the waterproofing membrane from adhering to the joint sealant, which could cause sealant or membrane failure, by applying a coat of wax or teflon tape over the cured sealant and then prestripping.

7 **Metal:** All metal must be wire brushed or sandblasted to bright metal. Prime with a quality rust-inhibiting metal primer and Sonneborn Primer 733 or 766 (see Technical Data Guide Form No. 1017962) before application of HLM 5000®.

8 **Vent, drain pipe, and post penetrations:** Clean metal surfaces to bright metal and prime with a quality rust-inhibiting metal primer followed by Primer 733 or 766. Remove dust, debris, and any other contaminants from voids. Seal with the appropriate Sonolastic® sealant.

Openings exceeding 1/8" (3 mm) must first be sealed with Sonolastic® sealant. Next, prestripe to a minimum width of 4" (102 mm) on the base slab and continue up the penetration to the height of the top-course wearing surface.

Application*

A test application is always recommended before proceeding with entire application.

Standard System

1 Select the grade of HLM 5000® that best meets individual job requirements. Use HLM 5000® T for trowel application, HLM 5000® S for spray application, HLM 5000® R for roller application, or HLM 5000® SL for squeegee application.

2 For horizontal applications, empty contents of pail and spread immediately to ensure workability. Best results are obtained by marking off 125 sq. ft. (11.61 m²) areas and evenly spreading the contents of a 5 gallon (18.93 L) unit with a rubber-edged notched squeegee. Repeat the above procedure until the entire surface is covered.

3 For vertical applications, apply by trowel, roller or spray at the rate of 25 sq. ft. per gallon (0.6 m²/L). Best results are obtained by marking off 125 sq. ft. (11.6 m²/L) and evenly applying the contents of a 5 gallon (18.93 L) pail.

4 Verify the applied thickness with a wet mil gauge as the work progresses.

5 The integrity of the cured membrane on a horizontal surface may be verified by damming the entire area and flooding with water to a minimum depth of 2" (51 mm) and allowing the water to stand for 24 - 48 hours. Visually inspect the bottom surface to check for any water penetration. If repairs are necessary, the area should be drained and allowed to dry before reapplying HLM 5000®. After re-application, the area should be tested again for membrane integrity.

High-build system

1 **Concrete application:** Apply 60 wet mils of HLM 5000®, followed by setting Sonoshield® Reinforcing Fabric into the wet material. Overlap all seams a minimum of 3" (76 mm). Additional material may be required to properly embed the reinforcing fabric where it overlaps.

2 Allow the first coat to cure overnight and follow with a second 60 wet-mil application of HLM 5000®.

3 **Plywood application:** All plywood construction must comply with APA (American Plywood Association) standards. Caulk all joints with a Sonolastic® sealant and then proceed with the HLM 5000® high-build system.

Spray equipment: For spray equipment recommendations, consult the equipment manufacturer.

Curing

Appreciable properties develop within 24 - 48 hours at 75°F (24°C) and 50% relative humidity. HLM 5000® should be protected from traffic during curing.

Drainage and Protection

1 For protection during backfill and where hydrostatic pressure is anticipated, use the appropriate Sonoshield® DBS Drain Board System. See Form No. 1017870 for installation instructions.

2 For protection during backfill only, install protection board as soon as possible following cure of HLM 5000®.

Clean Up

Clean all tools and equipment immediately after application with Sonneborn® Reducer 990.

***Note: Finish coat must be applied in a pinhole-free, continuous membrane for waterproofing integrity.**

How to Apply Protection Course II

Surface Preparation

1 Waterproofing membranes must be protected against tear, puncture, and other abuses during placement of concrete wearing slabs and reinforcing steel. They should also be protected from jobsite traffic and backfilling operations.

2 All specifications calling for membrane waterproofing should also require protection of membrane as an integral part of the overall waterproofing system.

Application

1 Install tightly butted Sonneborn® Protection Course II as soon as possible following cure of the liquid membrane. Protect HLM 5000® from traffic before placement of protection board. HLM 5000® must be cured before installation of any topping.

2 Where hot bituminous topping is to be applied over the 1/4" (6 mm) thick protection board, cover the butt joints with flexible tape. Minimum topping thickness is 3" (76 mm), as recommended by the Asphalt Institute, in order to minimize crack reflection.

How to Apply HLM 5000® Over Green Concrete

1 Strip the concrete forms and apply Hydrocide® 600 dampproofing at 70 to 100 ft.²/gallon (1.7 to 2.5 m²/L).

2 Allow Hydrocide® 600 to cure for 24 hours minimum. Cool temperatures and/or high humidity will slow the release of moisture from the coating.

3 Apply HLM 5000® in accordance with standard application instructions.

For Best Performance

HLM 5000®

- Apply HLM 5000® when substrates are dry and air temperatures are between 40°F (4°C) and 90°F (32°C); for application at temperatures below 40°F (4°C), consult Technical Services.
- Avoid application when inclement weather is present or imminent.
- Do not apply to reinforcing bars or to wet or contaminated surfaces.
- Use Sonneborn® Flextight™ (see Form No. 1017953) under thin-set tile applications.
- Protect HLM 5000® coated surfaces from puncture with protection board until required topping or backfill is placed.
- If project schedule does not permit 14-day minimum cure on concrete, contact Technical Service for primer recommendations.
- Carefully work material over irregular concrete to avoid pinholes and holidays.
- Not intended as an exposed or wearing surface.
- Do not use where a solvent odor is objectionable, e.g., near areas where food preparation or processing take place during the application.
- Specify wet or paper curing for concrete to be coated with HLM 5000®; avoid using liquid curing compounds.
- Before applying HLM 5000®, dam all drains and drain openings.
- Cold temperatures influence viscosity and handling characteristics of HLM 5000®; heat increases and cold decreases the flow. Keep HLM 5000® cool in hot weather and warm in cold weather.
- Do not directly heat containers with flame, stove, hot plate, or oven.
- Patch all voids and deep depressions in substrates with appropriate Sonneborn® patching material before applying HLM 5000®.
- Apply asphalt overlay in accordance with asphalt industry and manufacturer's standards. The HLM 5000® membrane must be protected from heat, impact, and any other damage that could be caused by an asphalt overlay.
- If board is exposed to prolonged periods of water immersion or excessive humidity, it may curl or wrinkle.
- Protection Course II to be covered with a concrete wearing course must be securely attached to membrane.
- Store Protection Course II on a flat surface and keep it dry; do not remove shrinkwrap until immediately before use.
- Make certain the most current version of this data guide is being used; call Customer Service (1-800-433-9517) to verify the most current version.
- Proper application is the responsibility of the user. Field visits by ChemRex® personnel are for the purpose of making technical recommendations only and are not for supervising or providing quality control on the jobsite.

Protection Course II

- Do not use 50 or 120 mil (1.3 or 3.0 mm) protection board in conjunction with bituminous overlays.

Technical Data

Compliances

- ASTM C 836
- National standard of Canada 37.58 - M86 developed by CCSB

Typical cured property*	HLM 5000® (self-leveling grade)		Method
	High-Build system	Standard system	
Shore 00 hardness	N/A	85	ASTM C 836
Viscosity, poise			Brookfield
HLM 5000® SL	125		
HLM 5000® S	450		
HLM 5000® R	800		
HLM 5000® T	4,000		
Tensile strength, psi (MPa)	200 (1.4)	150 (1.0)	ASTM D 412
Average elongation, %	300**	600	ASTM D 412
100% modulus, psi (MPa)	80 (0.6)	80 (0.6)	ASTM D 412
Minimum recovery, %	90	90	
Swelling in water, 3 days at room temperature	Nil	Nil	
Service temp. range, °F (°C)	-40 to +120 (-40 to 49)	-40 to +120 (-40 to 49)	
Moisture vapor permeability, perm inches dry	0.075	0.1	
Crack bridging test: cycled 10 times per 24 hours at 15°F (-9°C)	Passed 1/4 inch No loss of bond or cracking exhibited	Passed 1/16 inch No loss of bond or cracking exhibited	ASTM C 836
Extensibility after heat aging		No cracking	ASTM C 836
Adhesion in peel, lbs./inch (1 lb./inch min.)		5	ASTM C 836
Weight loss, % (20% max)		16	ASTM C 836

*Results shown are typical but are not intended as performance criteria for on-site installed material.

**Tested in direction of greatest elongation of fabric.

Sonoshield® Reinforcing Fabric Typical properties

Width, inches	Minimum: 37 - 1/2 Maximum: 38 - 1/2
Length, ft.	Minimum: 300 -0" Maximum: 300 +4"
Thickness, inches	(FTM-5136) 0.024 (-0.0, + 0.002)
Nominal weight, ounces per sq. yard	2.13
Construction, per sq. inch	34 by 30
Yarn denier	70

Sonoshield® Reinforcing Fabric Test data

Property	Method	Result
Elongation, %	ASTM 5034	Machine direction: 54 Cross direction: 147
Grab breaking, lbs.	ASTM 5034	Machine direction: 54 Cross direction: 32
Mullen burst, psi		70

Protection Course II Test data

Sheet property	Value	Method
Weight, lbs. per sq. ft.		
50 mil	0.188	
120 mil	0.428	
Burst strength, psi	175	ASTM D 2529
Puncture resistance, inch-pounds	45	ASTM D 781

Test results are averages obtained under laboratory conditions. Reasonable variations can be expected.

Order Information

HLM 5000® comes in a variety of grades for different applications.

- HLM 5000® SL (self-leveling) is formulated for application by squeegee to horizontal areas.
- HLM 5000® T (trowel) is formulated for application by trowel to vertical surfaces.
- HLM 5000® S (spray) is a specially formulated version of 5000T for spray application.
- HLM 5000® R (roller) is formulated for application by roller to vertical and some horizontal surfaces.
- Companion products to HLM 5000® are Primer 733 or 766 (see Form No. SJ-431), used for priming metal to be covered by HLM 5000®, and Reducer 990, used to clean tools and equipment.

Packaging

HLM 5000® SL, HLM 5000® S, and HLM 5000® R

- 5 gallon (19 L) pails; 55 gallon (208 L) drums are available on special order.

HLM 5000® T

- 5 gallon (19 L) pails only

Sonoshield® Reinforcing Fabric

- 300 ft. by 37-1/2 inches (91 by 0.9 m) rolls (937 sq. ft. or 87 m²)

Protection Course II

- 50 mil x 40" x 48" (1.3 mm x 1 m x 1.2 m) 500 sheets per pallet (13-1/3 sq. ft. [1.2 m²] per sheet) 6,665 sq. ft. (619 m²) per pallet
- 120 mil (1/8" or 3 mm) by 40" by 48" 500 sheets per pallet (13-1/3 sq. ft. [1.2 m²] per sheet) 6,665 sq. ft. (619 m²) per pallet
- 1/4" (6 mm) protection board is available on special order

Shelf Life of HLM 5000® is 6 months in unopened containers when stored in dry conditions between 40°F and 80°F (4°C and 27°C). During storage, an easily removed skin of HLM 5000® may form, which does not affect performance of the product.

Coverage

Wet mil thickness (mm)	Sq. ft. per gallon (m ² /L)
55 - 65 (1.4 - 1.7)	25 to 30 (0.61 - 0.74)

Dry mil thickness (mm)	Sq. ft. per gallon (m ² /L)
45 - 55 (1.1 - 1.4)	25 to 30 (0.61 - 0.74)

Note: Coverage may vary with the application technique used. Actual coverage rate and mil thickness depend on finish and porosity of the substrate.

Detail Drawings

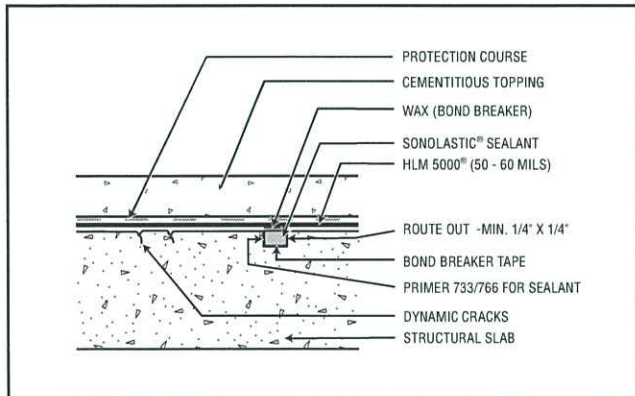

Dynamic Crack Detail

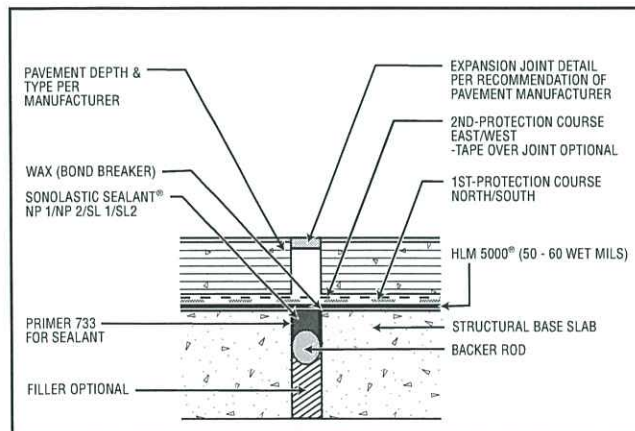

Asphalt Pavement Topping/Expansion Joint

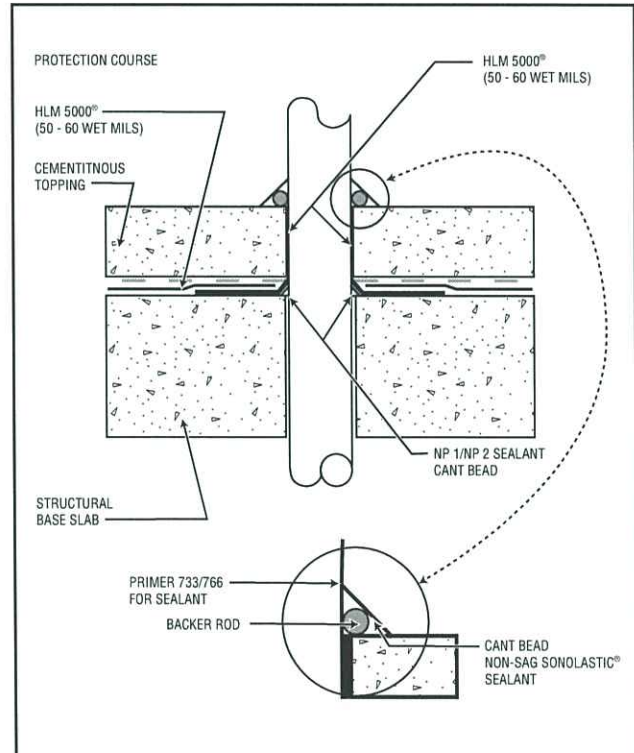

Vent/Drain/Pipe/Post Penetration Detail

Detail Drawings

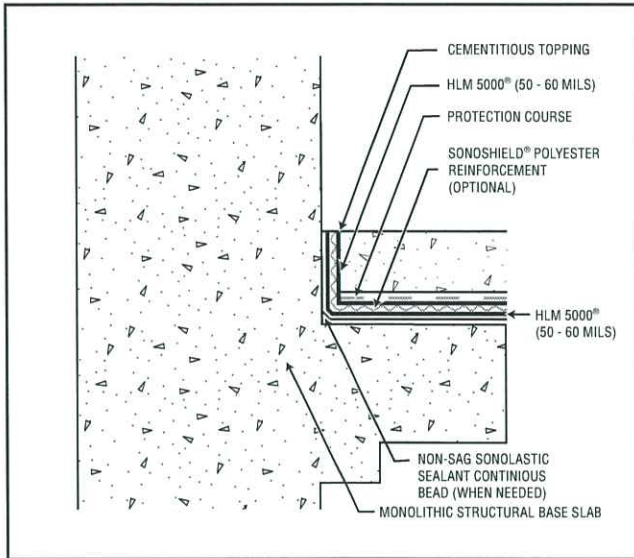

Inside Corner Detail (Static)

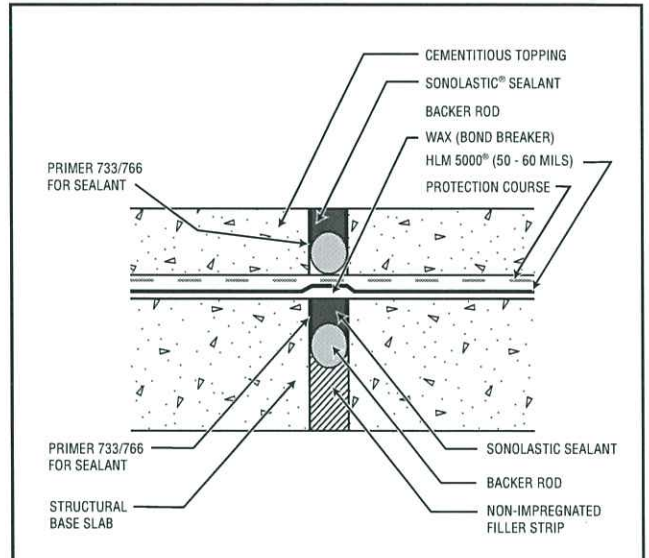

Expansion Joint Detail

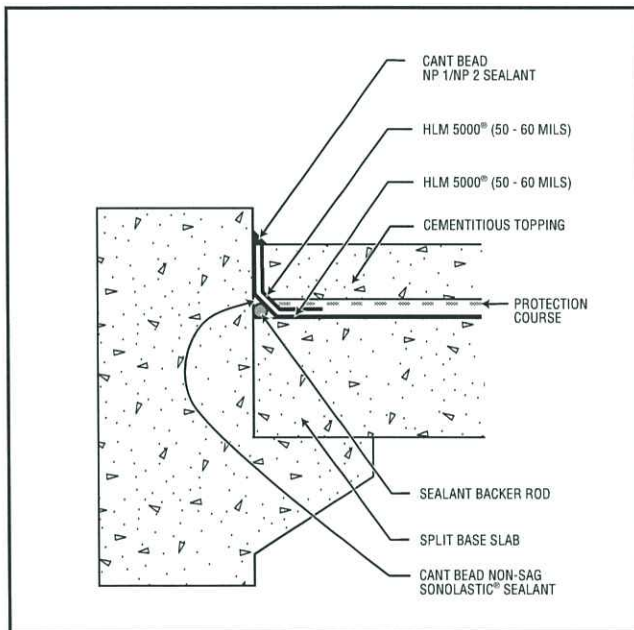

Split Slab with Cant Detail

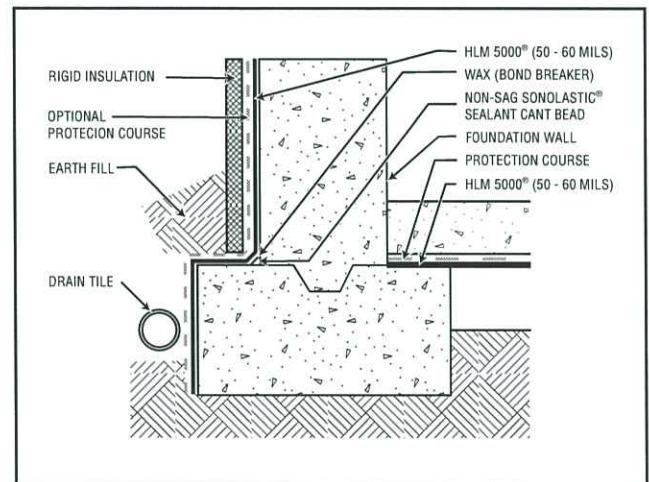

Waterproofing Foundation Walls

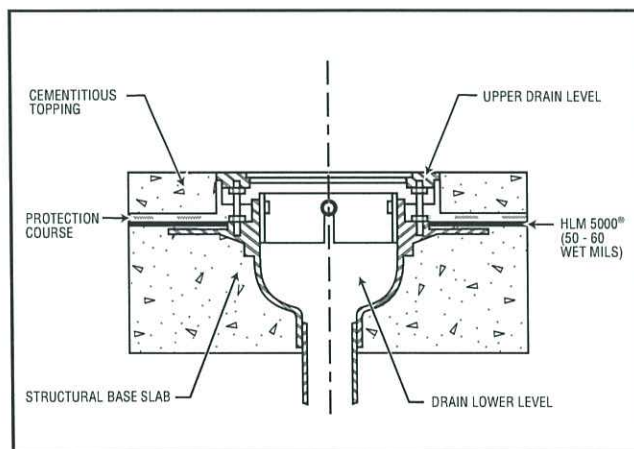

Waterproofing at Bi-Level Drain

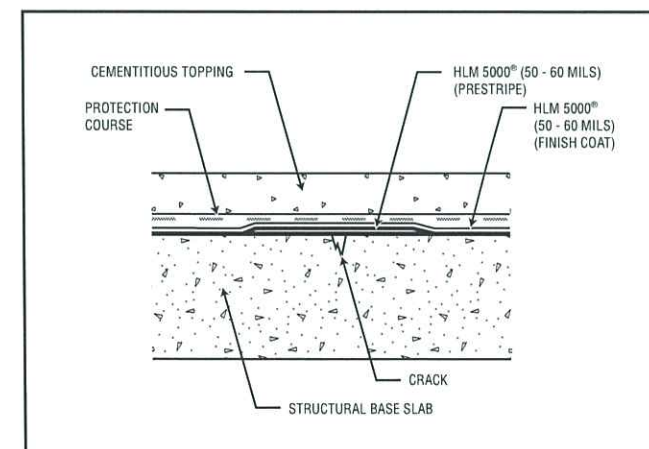

Static Crack/Prestripe Detail

Warning

HLM 5000® contains mineral spirits, naphtha-light aromatic, calcium oxide, toluene diisocyanate, silicon dioxide, talc, 1,2,4 trimethyl benzene, asphalt.

Risks

Combustible liquid and vapor. May cause skin, eye and respiratory irritation. May cause dermatitis and allergic responses. Potential skin and/or respiratory sensitizer. Ingestion may cause irritation of mouth, throat and stomach with nausea and abdominal pain. Reports associate repeated or prolonged occupational overexposure to solvents with permanent brain, nervous system, liver and kidney damage. INTENTIONAL MISUSE BY DELIBERATELY INHALING THE CONTENTS MAY BE HARMFUL OR FATAL.

Precautions

KEEP AWAY FROM HEAT, FLAME AND SOURCES OF IGNITION. KEEP OUT OF THE REACH OF CHILDREN. Keep container closed. Use only with adequate ventilation. Avoid contact with skin, eyes and clothing. Wash thoroughly after handling. Avoid breathing vapors. Use impervious gloves, eye protection and if the TLV is exceeded or if used in a poorly ventilated area, use NIOSH/MSHA approved respiratory protection in accordance with applicable federal, state and local regulations. Empty container may contain explosive vapors or hazardous residues. Do not cut or weld on or near empty container. All label warnings must be observed until container is commercially cleaned or reconditioned.

First Aid

In case of eye contact, flush thoroughly with water for at least 15 minutes. SEEK IMMEDIATE MEDICAL ATTENTION. In case of skin contact, wash affected areas with soap and water. If irritation persists, SEEK MEDICAL ATTENTION. Remove and wash contaminated clothing. If inhalation causes physical discomfort, remove to fresh air. If discomfort persists or any breathing difficulty occurs, or if swallowed, SEEK IMMEDIATE MEDICAL ATTENTION.

Refer to Material Safety Data Sheet (MSDS) for further information.

Proposition 65

This product contains materials listed by the state of California as known to cause cancer, birth defects or other reproductive harm.

VOC Content

HLM 5000® SL contains 183 g/L or 1.53 lbs. of VOC per gallon of coating. HLM 5000® S contains 190 g/L or 1.58 lbs. of VOC per gallon of coating. HLM 5000® R contains 180 g/L or 1.5 lbs. of VOC per gallon of coating. HLM 5000® T contains 132 g/L or 1.1 lbs. of VOC per gallon of coating.

For medical emergencies only, call ChemTrec (1/800/424-9300)

Limited Warranty Notice

Every reasonable effort is made to apply ChemRex® exacting standards both in the manufacture of our products and in the information which we issue concerning these products and their use. We warrant our products to be of good quality and will replace or, at our election, refund the purchase price of any products proved defective. Satisfactory results depend not only upon quality products, but also upon many factors beyond our control. Therefore, except for such replacement or refund, CHEMREX® MAKES NO WARRANTY OR GUARANTEE, EXPRESS OR IMPLIED, INCLUDING WARRANTIES OF FITNESS FOR A PARTICULAR PURPOSE OR MERCHANTABILITY, RESPECTING ITS PRODUCTS, and CHEMREX® shall have no other liability with respect thereto. Any claim regarding product defect must be received in writing within one (1) year from the date of shipment. No claim will be considered without such written notice or after the specified time interval. User shall determine the suitability of the products for the intended use and assume all risks and liability in connection therewith. Any authorized change in the printed recommendations concerning the use of our products must bear the signature of the ChemRex® Technical Manager.



Sonneborn®

ChemRex®

Corporate Office:

889 Valley Park Drive; Shakopee, MN 55379

Customer Service: 1/800/433-9517

Technical Services: 1/800/ChemRex (1/800/243-6739)

Web Site: www.chemrex.com