



工程指示 / 要求簡箋(E.I.)

工程指示編號：EI / 2921 / 21 修改版次：-
 工程編號 : J - 852 工程名稱 : 亞皆老街中電
 工程項目 : 佛沙窗 師父板 (3rd)
 收件人 : 生統 / 王良 發件人 : Ant Yeung 日期 : 07/01/2021

要求提供 / 確認 事項 :

- | | | |
|------------------------------------|-------------------------------------|-------------------------------|
| <input type="checkbox"/> 初步鋁料 B.M. | <input type="checkbox"/> 加工拆圖，然後生產 | <input type="checkbox"/> 尺寸表 |
| <input type="checkbox"/> 正式鋁料 B.M. | <input type="checkbox"/> 技術上資料 / 指示 | <input type="checkbox"/> 報價 |
| <input type="checkbox"/> 配件 B.M. | <input type="checkbox"/> 樣辦或貨品說明書 | <input type="checkbox"/> 分判合約 |

請按加工圖生產佛沙窗師父板 (收貨用)

送貨單 17.3.18

請參考附件+按顧問於 2020.09.08 及 2020.12.23 審視的事項才出貨. *

#1 所有螺絲孔位置要 o 必膠，見膠噴

#2 轉角位膠條不能鬆脫

#3、噴塗脫色，要補油

#4 45 度角要多一點點膠

#5 滴水線刀口位要補油

#6 45 度不能起級，不齊

#7 窗玉不能大細邊，要對對角線

#8 窗玉 45 度要補油

謝謝留意。

請在 2021.01.14 到香港 前完成上列要求。

附有關圖紙 / 文件 : 2 份報告 十 25 頁

分發東莞各部門 :

- | | | | |
|--|---|---|--|
| <input type="checkbox"/> 生產技術總監 <input type="checkbox"/> 連附件 | <input type="checkbox"/> 技術部 <input type="checkbox"/> 連附件 | <input type="checkbox"/> 生產部 <input type="checkbox"/> 連附件 | <input type="checkbox"/> 機械設計部 <input type="checkbox"/> 連附件 |
| <input type="checkbox"/> 採購部 <input type="checkbox"/> 連附件 | <input type="checkbox"/> 生產統籌部 <input type="checkbox"/> 連附件 | | |
| <input type="checkbox"/> 質檢部 <input type="checkbox"/> 連附件 | <input type="checkbox"/> 會計部 <input type="checkbox"/> 連附件 | <input type="checkbox"/> 報關組 <input type="checkbox"/> 連附件 | <input checked="" type="checkbox"/> 其他 <i>Gary</i> <input checked="" type="checkbox"/> 連附件 |

分發其他分判 :

- (v) 水洪 連附件

分發香港各部門 :

- | | | | |
|---|--|---|--|
| <input type="checkbox"/> 行政部 <input type="checkbox"/> 連附件 | <input type="checkbox"/> 會計部 <input type="checkbox"/> 連附件 | <input type="checkbox"/> 統籌部 <input type="checkbox"/> 連附件 | <input type="checkbox"/> 工程部地盤科文 <input type="checkbox"/> 連附件 |
| <input type="checkbox"/> 採購部 <input type="checkbox"/> 連附件 | <input type="checkbox"/> QS 部 <input type="checkbox"/> 連附件 | <input type="checkbox"/> 維修部 <input type="checkbox"/> 連附件 | <input type="checkbox"/> 其他 _____ <input type="checkbox"/> 連附件 |

傳遞編號 :

HK 0064 / 21

發件人簽署 :

項目經理簽署 :

From ei 2140A

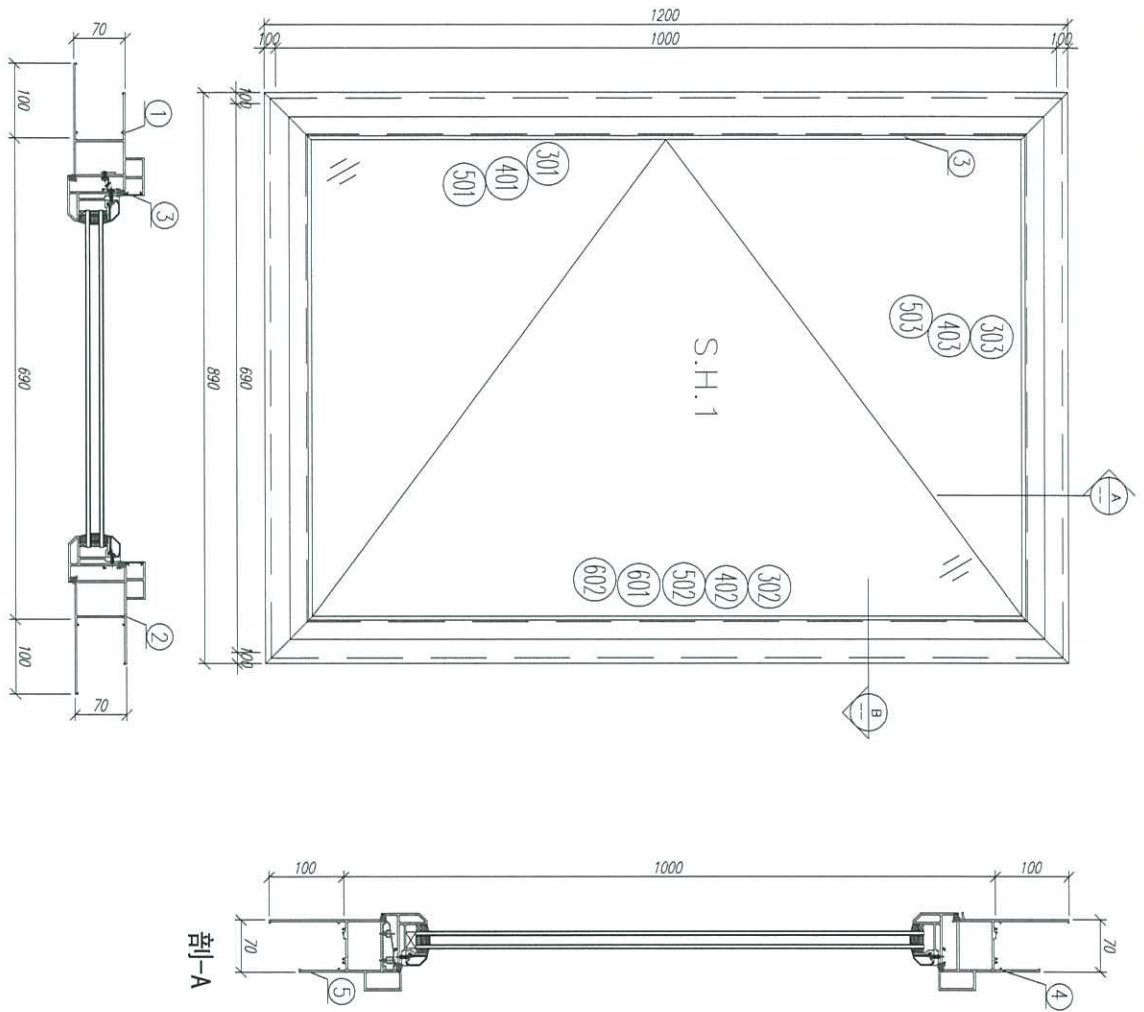

序號	材料編號	材料名稱	加工圖號	長度 L (MM)	單位	數量	備註
1	X85759	70生窗邊框	PW01-H01	1200	支	1	1
2	X85759	70生窗邊框	PW01-H01R	1200	支	1	1
5	X85764	70生窗拍蓋	直口開料	846	支	2	2
6	X85761	70生窗頂框	PW01-W01	890	支	1	1
7	X85762	70生窗底框	PW01-W01R	890	支	1	1
如下為生玉/櫻玉料							
301	X85767	70生窗玉企	PW02-H01	900	支	1	1
302	X85767	70生窗玉企/投手	PW02-H01R	900	支	1	1
303	X85767	70生窗玉企頂/底	PW02-W01	590	支	2	2
401	X85834	70窗玻璃夾角企	PW03	827	支	1	1
402	X85834	70窗玻璃夾角企/投手	PW03a	827	支	1	1
403	X85834	70窗玻璃夾角框	PW03	467	支	2	2
501	X85768	70窗玻璃線企/投手	直口開料	827	支	1	1
502	X85768	70窗玻璃線企	斜口開料	827	支	1	1
504	X85768	70窗玻璃線企	斜口開料	487	支	2	2
601	X85824	多點鎖拉巴		303	支	1	1
602	X85824	多點鎖拉巴		320	支	1	1
如下為配件資料							
701	837-CWG-S1	防水膠塞			米	3.2	3.2
702	東成-TG903	扣碼			組	2	2
703	美國膠棒	14"			支	2	2
704	東成201-08	鎖扣			個	2	2
705	東成202-06	鎖點			個	2	2
706	HD-AW-01	窗粘			個	1	1
707	東成-2035-B	多點鎖鎖盒			套	1	1

數量: 1	材料: 详见本图附表	表面處理: UCT806812XL-3
制圖: IVAN	日期: 2020.07.21	校核: WSH
審核: WSH	Rev: A	
工程名稱: J852-亞皆老街 / 佛沙窗	圖名: HUN0016組裝圖	圖號: UN-01A

From 2140A

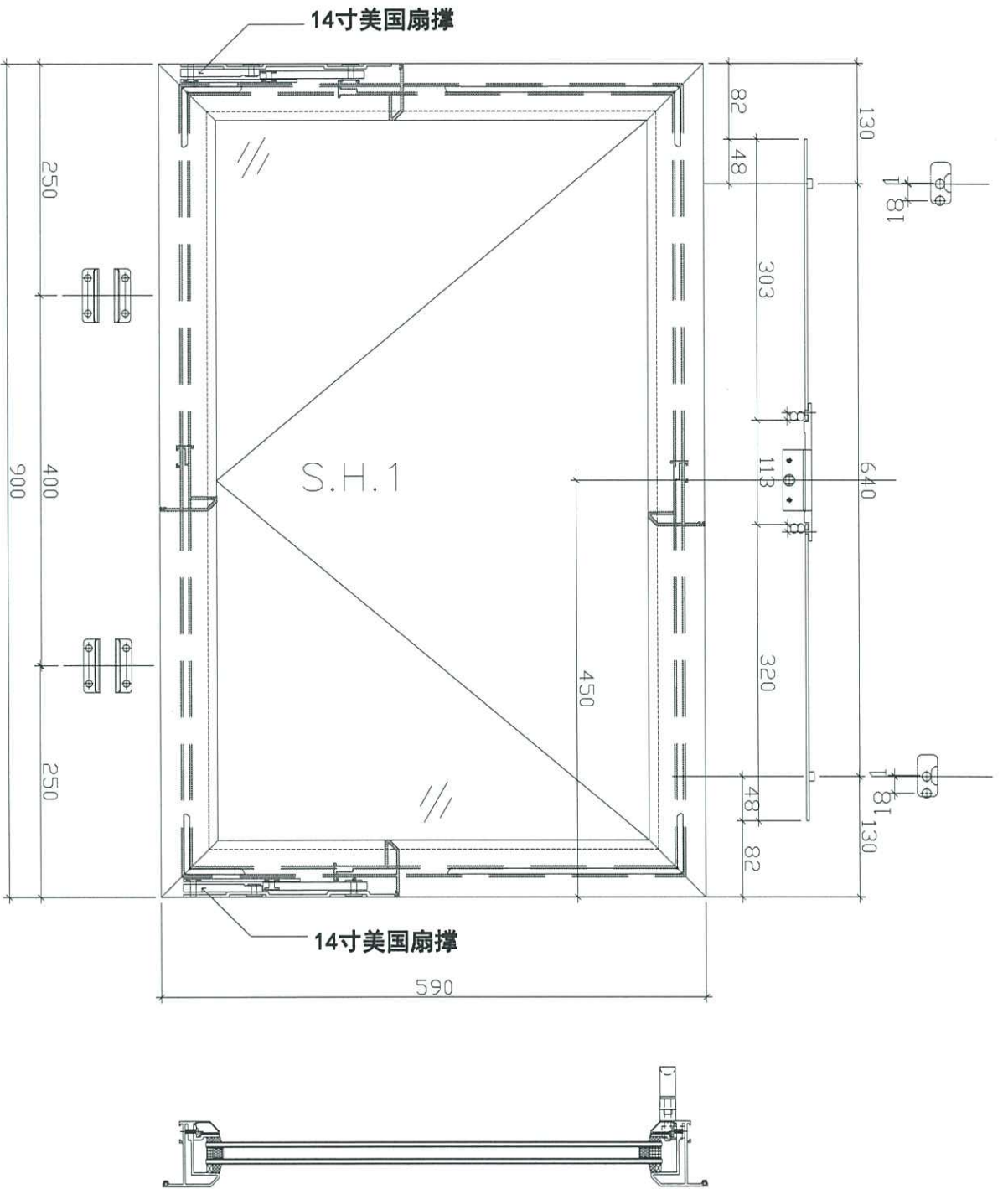

数量:	材料:	表面处理:
制图: IVAN	日期: 2020.07.21	UC1806812XL-3
校核:	审核:	Rev:

 美特铝质有限公司
MIDI Aluminium Fabricator Ltd.

工程名称:	J852-亞皆老街 / 佛沙窗
图名:	窗玉放樣圖
图号:	S.H.01

請用A3紙打印

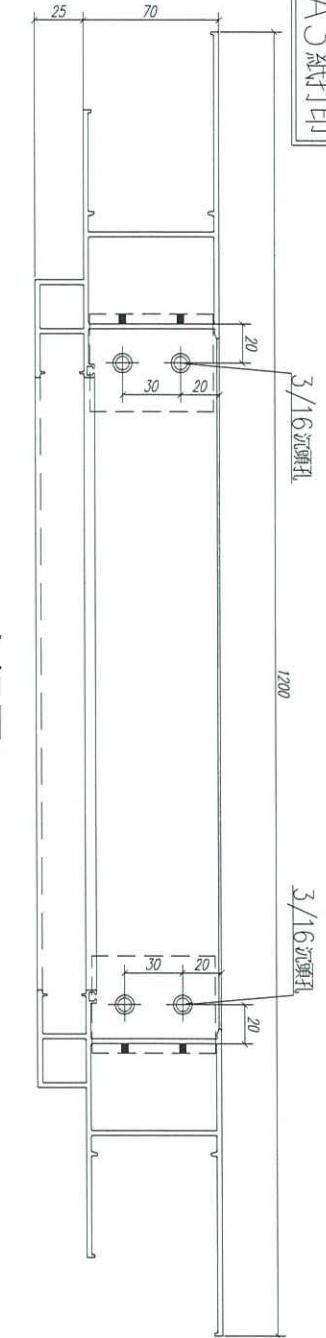

右视图1

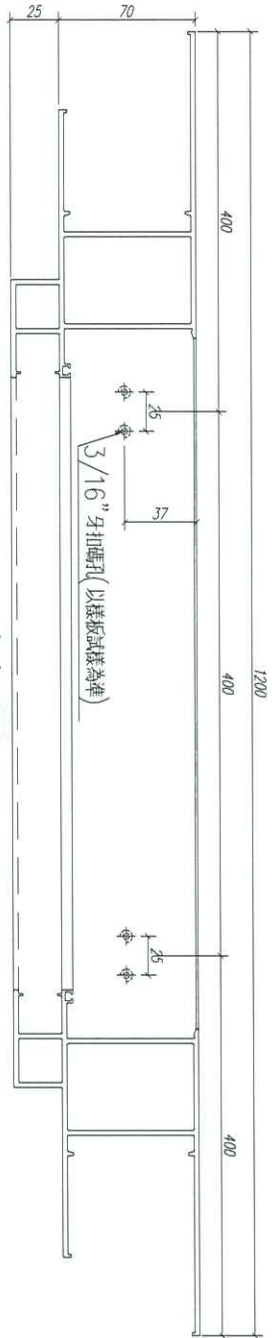

右视图2

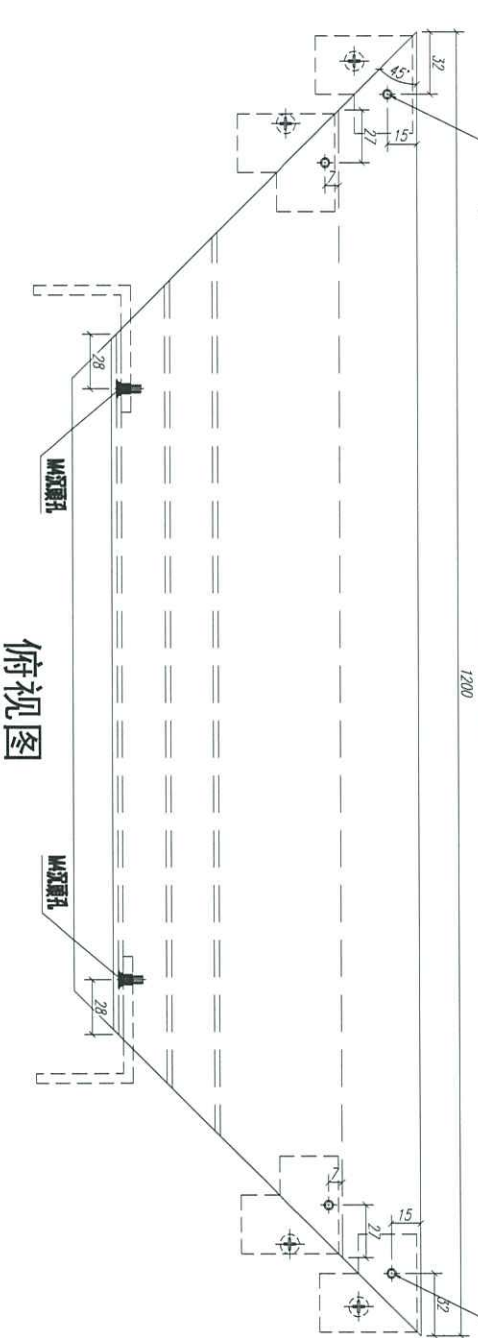

俯视图

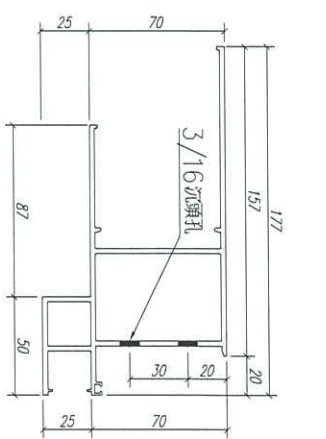

顶

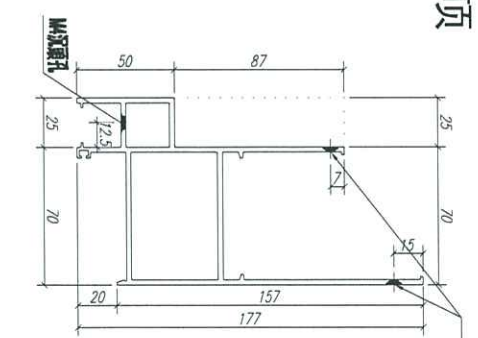
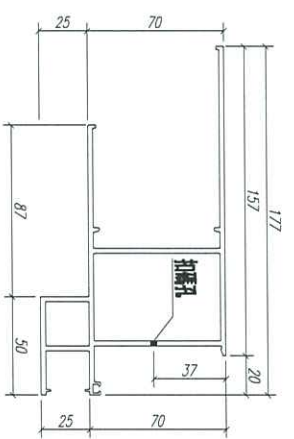

注: 工厂安装

数量: 1

材料: X85759

表面处理: UC1806812XL-3

制图: Ivan

日期:

REV:

校核:

审核:



美特铝质有限公司
MIDI Aluminium Fabricator Ltd.

工程名称:

J852-亞皆老街 / 佛沙窗

图名: 70生窗邊框

图号: PM01-H01

From ei 2140A

請用A3紙打印

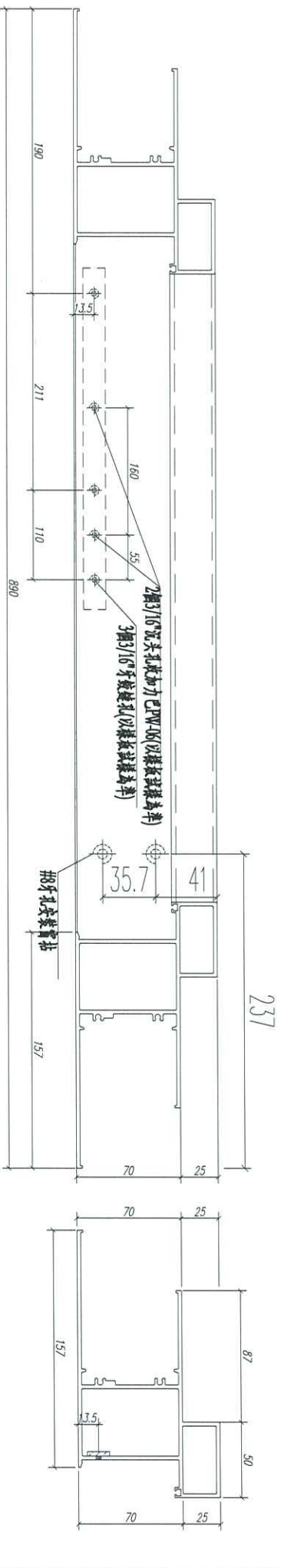
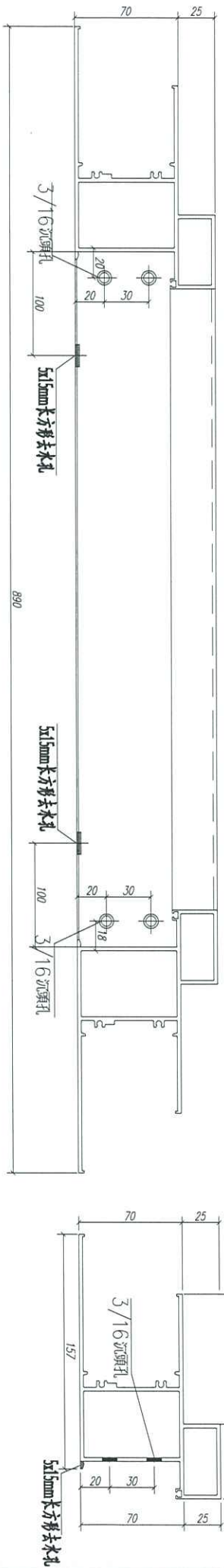
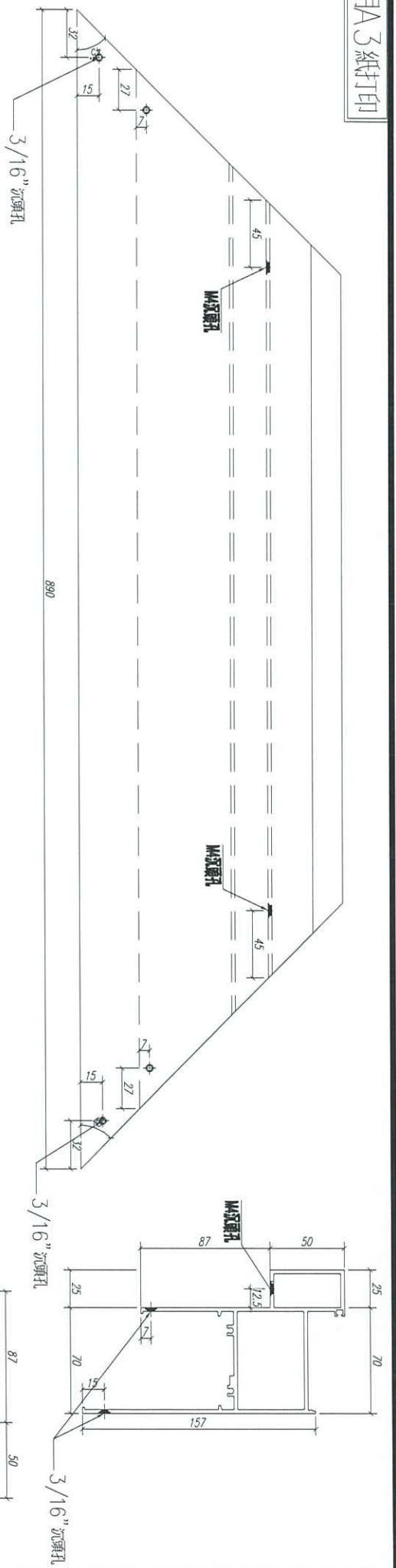

数量: 1

材料: X85762

表面处理: UC1806812XL-3

工程名称: J852-亞皆老街 / 佛沙窗

制图: Ivan

日期:

REV:

校核:

审核:



美特鋁質有限公司
MIDI Aluminium Fabricator Ltd.

图名: 70生窗邊框

图号: PM01-W01R

From Qi 2140A

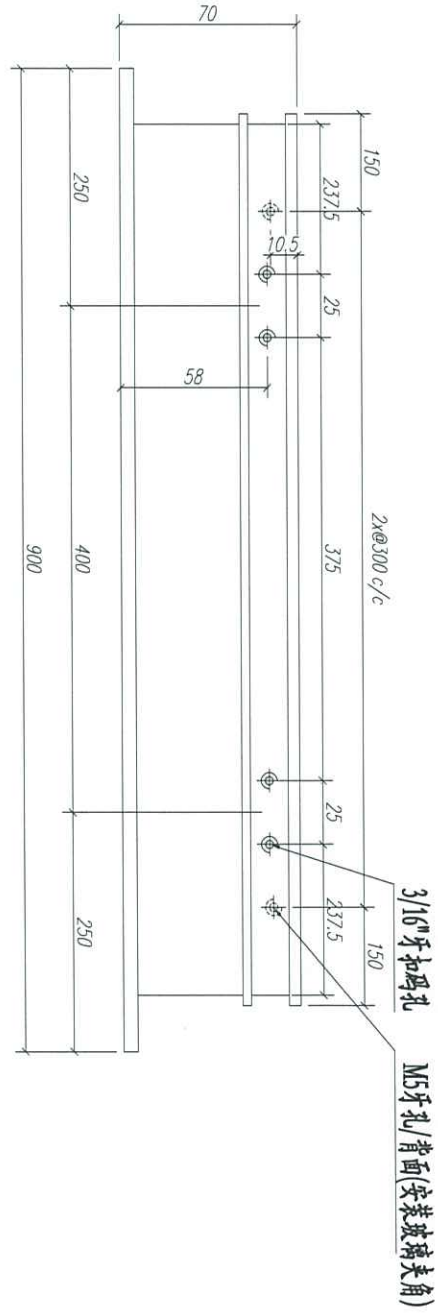
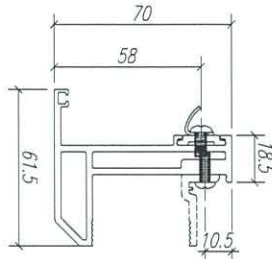

3/16" 牙扣螺孔
M5 牙孔/背面(安裝玻璃夾角)

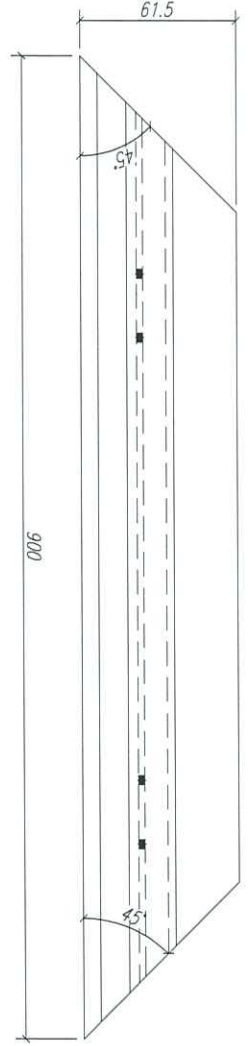

数量: 1
材料: X85767
表面处理: UC1806812XL-3

制图: Ivan
日期:
REV:
校核:
审核:



工程名称: J852-亞皆老街 / 佛沙窗

图名: 70生窗玉
图号: PM02-H01

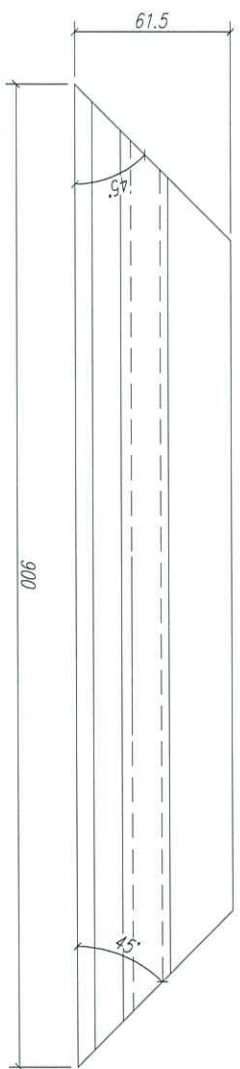
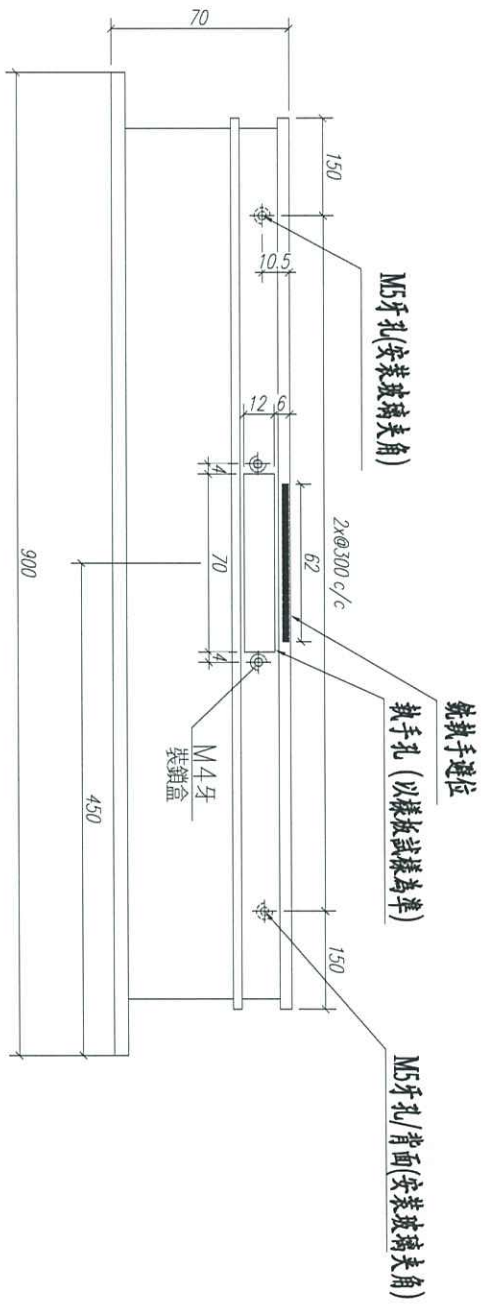
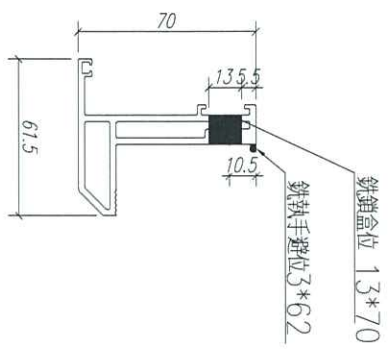

数量: 1	材料: X85767	表面处理: UCT806812XL-3
制图: Ivan	日期:	REV:
	校核:	审核:



美特铝質有限公司

工程名称: J852-亞皆老街 / 佛紗窗	图名: 70生窗玉	图号: PW02-H01R
-----------------------	-----------	---------------

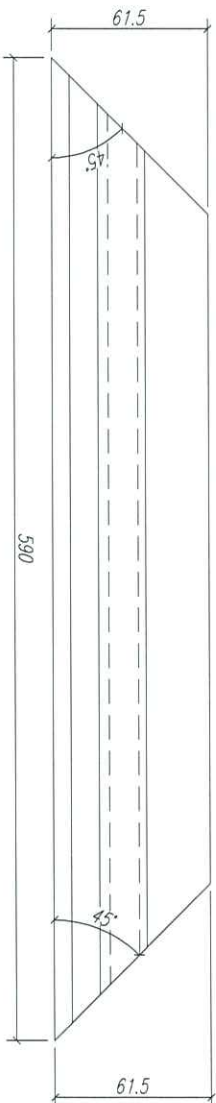
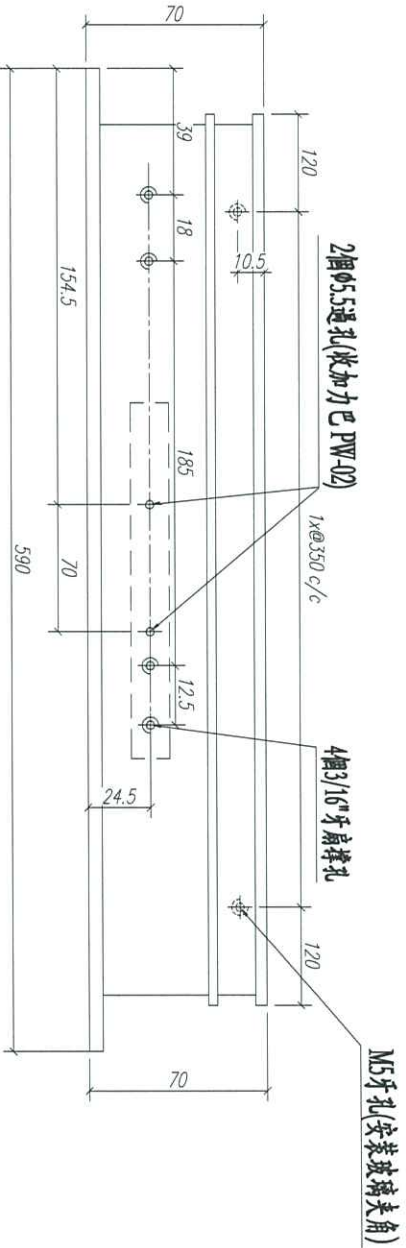
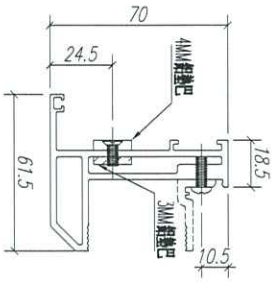

数量: 2

材料: X85T67

表面处理: UCT806812XL-3

制图: Ivan

日期:

REV:

审核:

审核:



美特铝质有限公司
 MIDI Aluminium Fabricator Ltd.

工程名称:

J852-亞皆老街 / 佛沙窗

图名: 70生窗玉(顶)

图号: PW02-W01

請用A3紙打印

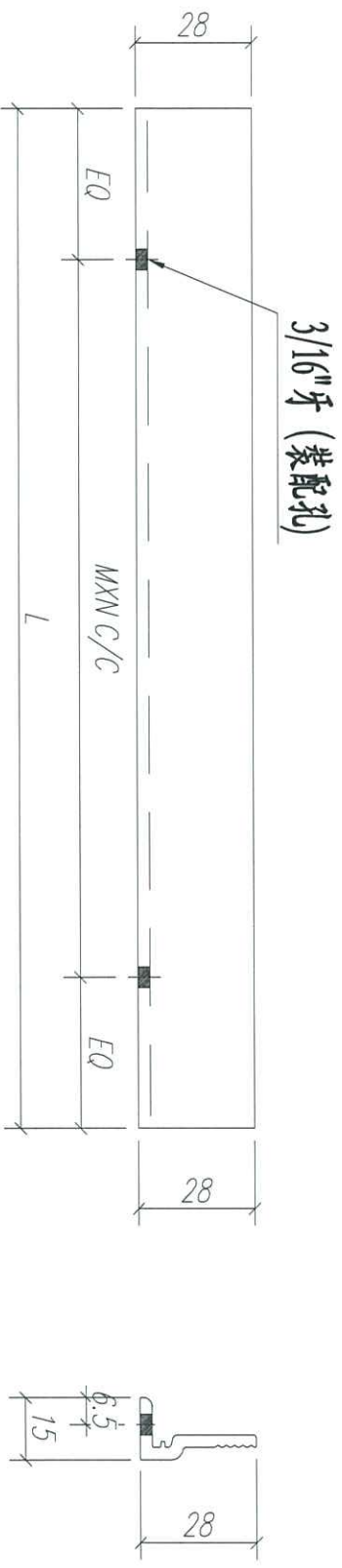

注: GC——工厂安装, GD——工地安装

序号	加工图号	长度 L (MM)	数量	M	N	装配窗号	场地
5							GC
3	PW03-W01	467	2	350	1		GC
1	PW03-H01	827	1	300	2		GC

数量: 见附表	材料: X85634	表面处理: UCT806812XL-3		
制图: Ivan	日期:	REV: B	审核:	审核:
 美特铝质有限公司 MIDI Aluminium Fabricator Ltd.		工程名称: J852-亞皆老街 / 佛沙窗 图名: 70窗玻璃夾角 图号: PW03		

From 2140A

請用A3紙打印

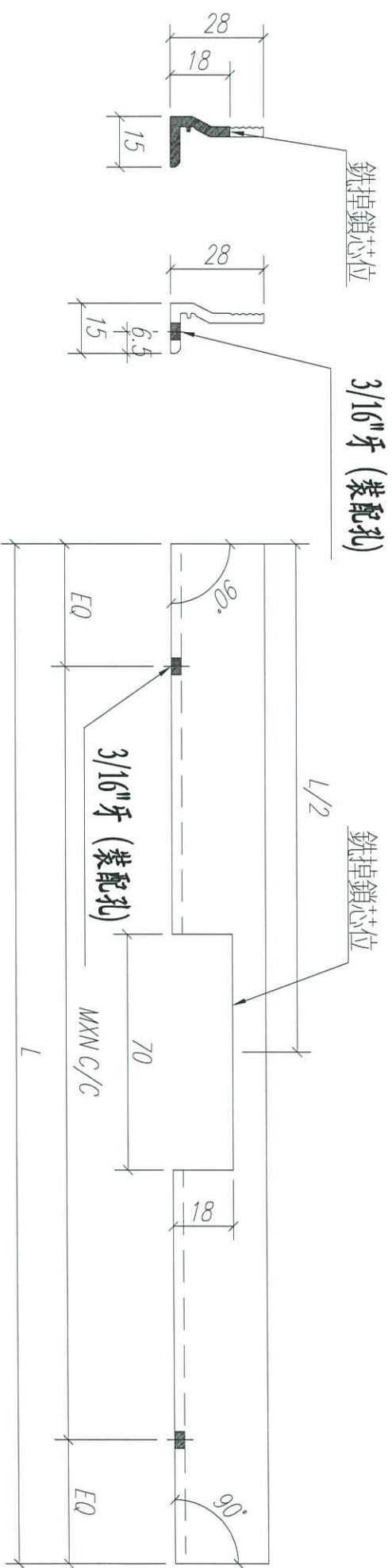

注: 60——工厂安装, 6D——工地安装

序号	加工图号	长度 L (MM)	数量	M	N	装配窗号	场地
1	PW03a-H01	827	1	300	2		GC

数量: 见附表	材料: X85634	表面处理: UCT806812XL-3
制图: Ivan	日期:	REV:
	校核:	审核:

美特铝质有限公司
MIDI Aluminium Fabricator Ltd.

工程名称: J852-亞皆老街 / 佛沙窗	图名: 70窗玻璃夾角	图号: PW03a
-----------------------	-------------	-----------

Fmm ei 2140A

請用A3紙打印

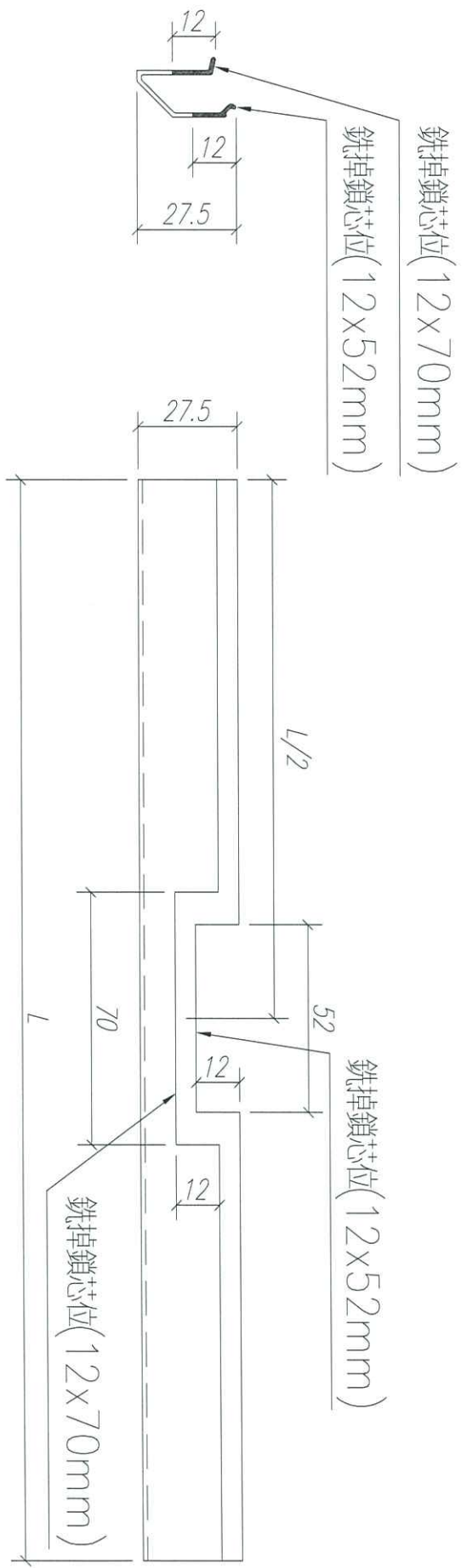

注: GC——工厂安装, GD——工地安装

序号	加工图号	长度 L(MM)	数量	装配窗号	场地
1	PW04-H11-01	827	1		GC

数量: 1 材料: X85768 表面处理: UC1806812XL-3

制图: Ivan 日期: REV: - 校核: 审核:



工程名称: J852-亞皆老街 / 佛沙窗
 图名: 70生窗玻璃壓線
 图号: PW04

From 2140A



美特鋁質有限公司
MIDI ALUMINIUM FABRICATOR LTD

工程號碼: J852, 工程名稱: 佛沙窗框 (重做看板)

開料長度: 5800, 總長料支數: 1, 總開料支數: 4

鋸片厚度(mm): 6, 料頭尾總切除(mm): 50, 浪費率(%): 67.69

鋁材開料清單 X85767

窗號	編號(用料狀況)	實用長度(長料開數)	需要 支數	開料 支數	長料 支數	餘料 支數	編號(剩餘長度)
	1	500.0	2	2	1	0	1@(4738)x1
	(餘料)1	400.0	2	2	0	1	1@(3926)x1



美特鋁質有限公司
MIDI ALUMINIUM FABRICATOR LTD

工程號碼: J852, 工程名稱: 佛沙窗框 (重做看板)

開料長度: 5800, 總長料支數: 1, 總開料支數: 4

鋸片厚度(mm): 6, 料頭尾總切除(mm): 50, 浪費率(%): 72.31

鋁材開料清單 X85834

窗號	編號(用料狀況)	實用長度(長料開數)	需要 支數	開料 支數	長料 支數	餘料 支數	編號(剩餘長度)
	1	433.0	2	2	1	0	1@(4872)x1
	(餘料)1	333.0	2	2	0	1	1@(4194)x1



美特鋁質有限公司
MIDI ALUMINIUM FABRICATOR LTD

工程號碼: J852, 工程名稱: 佛沙窗框 (重做看板)

開料長度: 5800, 總長料支數: 1, 總開料支數: 4

鋸片厚度(mm): 6, 料頭尾總切除(mm): 50, 浪費率(%): 72.38

鋁材開料清單 X85768

窗號	編號(用料狀況)	實用長度(長料開數)	需要 支數	開料 支數	長料 支數	餘料 支數	編號(剩餘長度)
	1	432.0	2	2	1	0	1@(4874)x1
	(餘料)1	332.0	2	2	0	1	1@(4198)x1

工程號碼: J852, 工程名稱: 佛沙窗框 (重做看板)

開料長度: 4500, 總長料支數: 1, 總開料支數: 2

鋸片厚度(mm): 6, 料頭尾總切除(mm): 30, 浪費率(%): 79.24

鋁材開料清單 X85764

窗號	編號(用料狀況)	實用長度(長料開數)	需要 支數	開料 支數	長料 支數	餘料 支數	編號(剩餘長度)
	1	446.0	2	2	1	0	1@(3566)x1

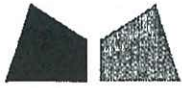

美特鋁質有限公司
MIDI ALUMINIUM FABRICATOR LTD

工程號碼: J852, 工程名稱: 佛沙窗框 (重做看板)

開料長度: 5800, 總長料支數: 1, 總開料支數: 1

鋸片厚度(mm): 6, 料頭尾總切除(mm): 30, 浪費率(%): 87.31

鋁材開料清單 X85762

窗號	編號(用料狀況)	實用長度(長料開數)	需要 支數	開料 支數	長料 支數	餘料 支數	編號(剩餘長度)
	1	700.0	1	1	1	0	1@(5064)x1

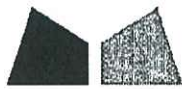

美特鋁質有限公司
MIDI ALUMINIUM FABRICATOR LTD

工程號碼: J852, 工程名稱: 佛沙窗框 (重做看板)

開料長度: 5650, 總長料支數: 1, 總開料支數: 1

鋸片厚度(mm): 6, 料頭尾總切除(mm): 30, 浪費率(%): 86.97

鋁材開料清單 X85761

窗號	編號(用料狀況)	實用長度(長料開數)	需要支數	開料支數	長料支數	餘料支數	編號(剩餘長度)
	1	700.0	1	1	1	0	1@(4914)x1



美特鋁質有限公司
MIDI ALUMINIUM FABRICATOR LTD

工程號碼: J852, 工程名稱: 佛沙窗框 (重做看板)

開料長度: 4850, 總長料支數: 1, 總開料支數: 2

鋸片厚度(mm): 6, 料頭尾總切除(mm): 50, 浪費率(%): 65.73

鋁材開料清單 X85759

窗號	編號(用料狀況)	實用長度(長料開數)	需要 支數	開料 支數	長料 支數	餘料 支數	編號(剩餘長度)
	1	800.0	2	2	1	0	1@(3188)x1

Site Memorandum

To : Gammon Engineering & Construction Co., Ltd Ref no : 1980045.1-SM-50003-00
Attn : Mr. Dick Yuen / Mr. Jackson Mok Date : 9 September 2020
From : Ms. Cosimo Wong / Mr. Neo Wong Required Reply Date: 14 days
Project : Proposed Residential Development at 139 – 147 Argyle Street, Kowloon
Subject : Façade Works – Site Inspection Report #6

Refer to site inspection regarding the captioned, we enclose herewith the Site Inspection Report #6 (31 Aug - 4 Sept 2020) for your team to take necessary follow up actions and defects rectification immediately.

Best Regards,



Cosimo Wong

Distribution (by email)

SINO (PM)	-	Mr. Billy Tang / Mr. Jimmy Cheung	w/e
SINO (OSR)	-	Mr. Edwin Chow	w/e
AGC	-	Ms. Grace Cheng / Mr. Raymond Ho / Mr. Eliot Chan	w/e
ARUP	-	Mr. Johnson Po / Mr. Jessy Zhang	w/e
Midi	-	Mr. Marco Tam / Ms. Bessie Lau	w/e
MFT Office	-	Mr. Brian Leung / Ms. Yoanna Chan	w/e

Proposed Residential Development at 139-147 Argyle Street, Kowloon

Site Inspection Report # 06

Inspection Date: 31st August – 4th September 2020

1980045.1MFHK-SI-RPT-006-00

Submitted To

Pacific Shine Ltd.

Prepared By

Meinhardt Façade Technology (HK) Ltd

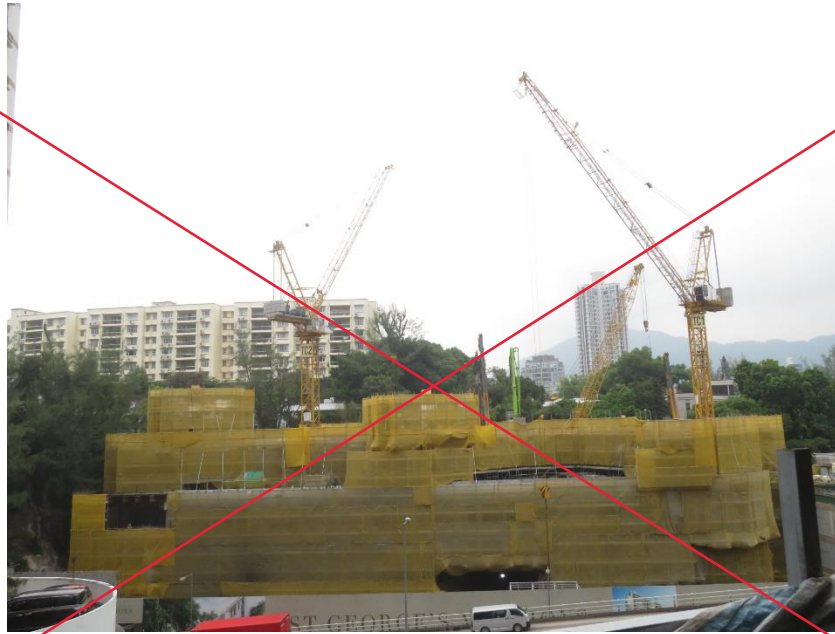

Photo #1

Observation	Overview of the project.
Recommendation	-

師傅板



Photo #2

Observation (Alum Window)	Joint inspection for reviewing the rectification status of alum window sample was carried out with Gammon and Midi on 1 st September 2020.
Recommendation	-

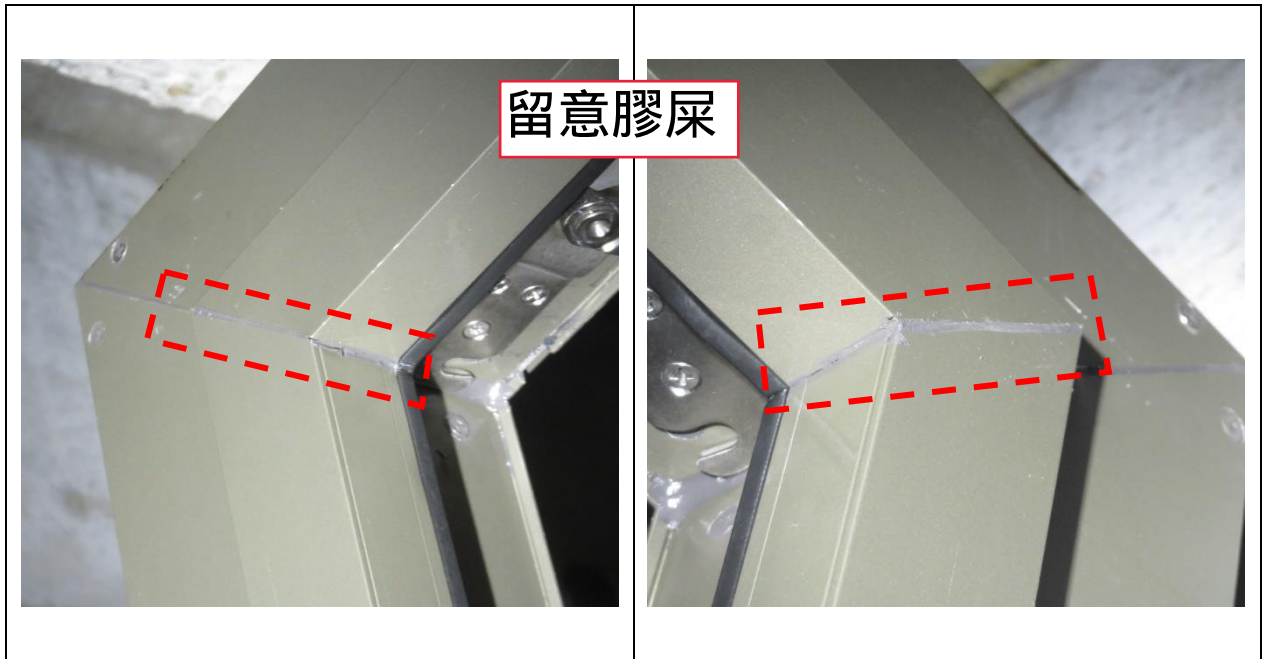

Photo #9

Observation (Window Frame)	Sealant was applied to the tight joints at window frame and sash. However, untidy sealant joints were observed.
Recommendation	Rectification work was carried out with reference to MFT's report 1980045.1MFHK-FI-RPT-002-00 Photo #13. Workmanship for sealant application should be improved.



Photo #10

Observation (Window Frame)	A severe damage was noted on the coated surface.
Recommendation	No rectification work was carried out with reference to MFT's report 1980045.1MFHK-FI-RPT-002-00 Photo #14.



Photo #11

Observation (Window Frame)	Re-application of bitumen paint to the area which to be in contact with precast concrete was noted.
Recommendation	Rectification work was carried out with reference to MFT's report 1980045.1MFHK-FI-RPT-002-00 Photo #15. It is further reminded to improve the workmanship of applying bitumen paint in factory.

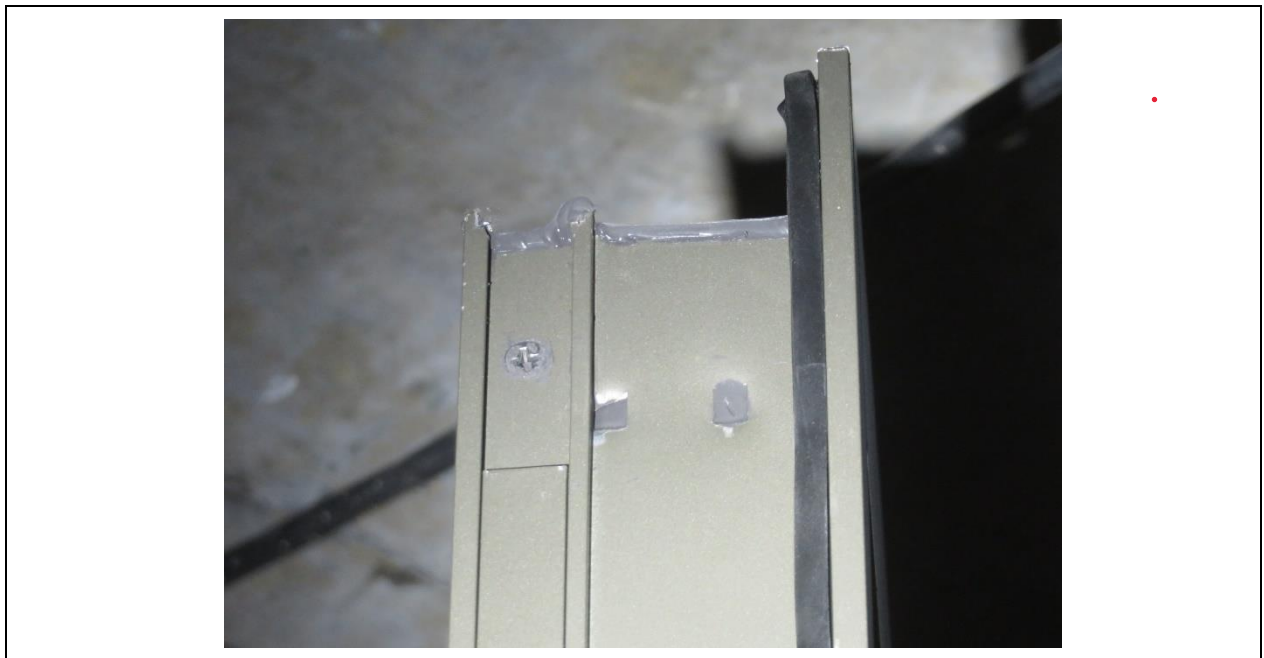

Photo #12

Observation (Window Sash)	Excessive sealant on the corner of a sash was removed.
Recommendation	Rectification work was carried out with reference to MFT's report 1980045.1MFHK-FI-RPT-002-00 Photo #16.

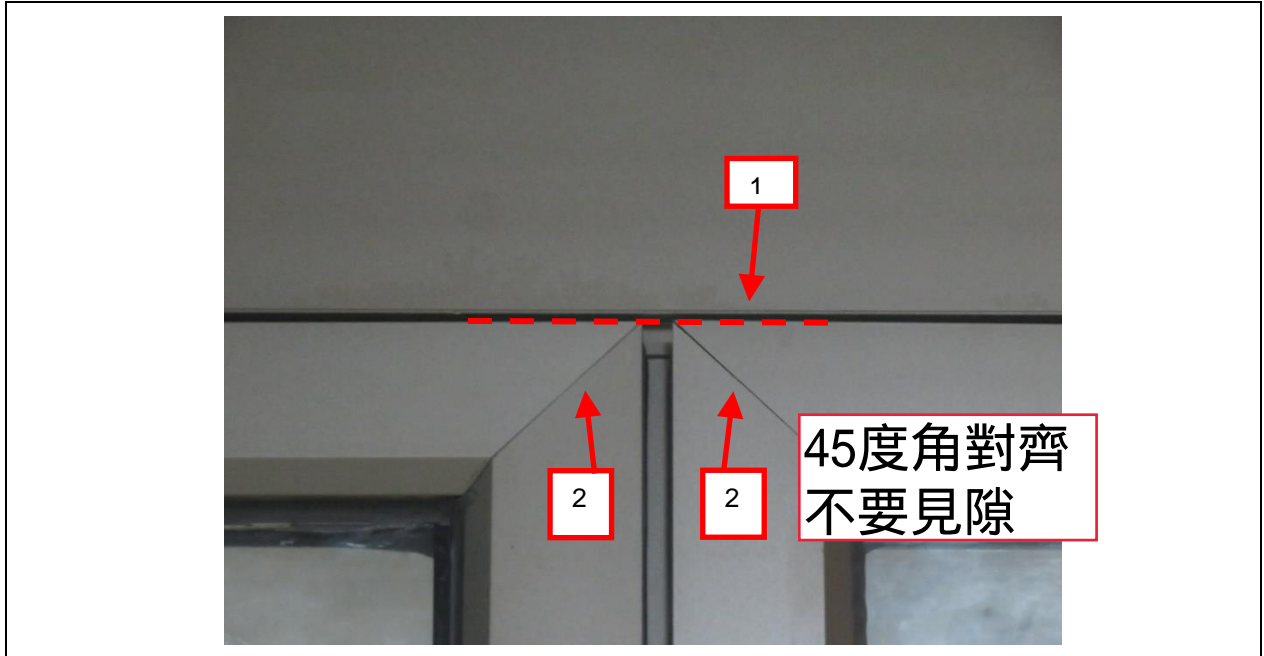

Photo #13

Observation (Window Sash)	1) Alignment between sashes was adjusted. 2) Uneven mitre joints could still be observed.
Recommendation	Rectification work was carried out with reference to MFT's report 1980045.1MFHK-FI-RPT-002-00 Photo #17. It is further reminded to improve the quality of fabrication as well as assembly in factory.

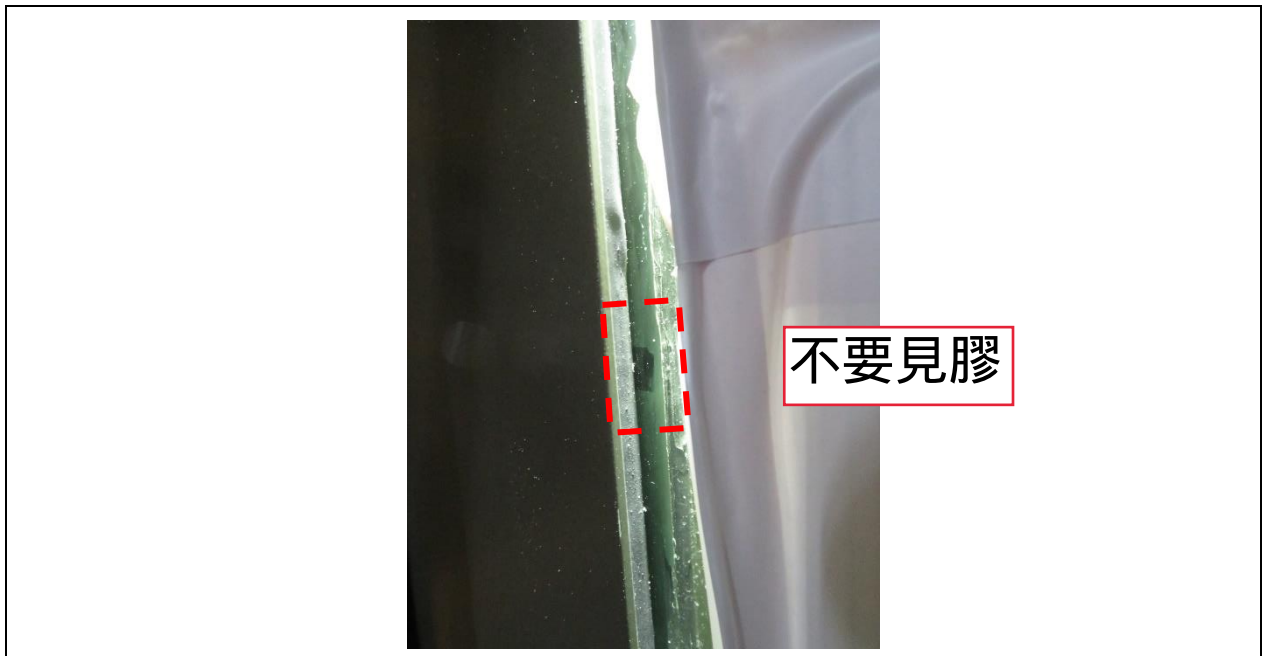

Photo #14

Observation (Glass Barrier)	Some spacers in the sealant joint around barrier glass were noticeable.
Recommendation	No rectification work was carried out with reference to MFT's report 1980045.1MFHK-FI-RPT-002-00 Photo #20.



Photo #15

Observation (Glass Barrier)	Poor workmanship was observed at a location of sealant joint.
Recommendation	No rectification work was carried out with reference to MFT's report 1980045.1MFHK-FI-RPT-002-00 Photo #21.

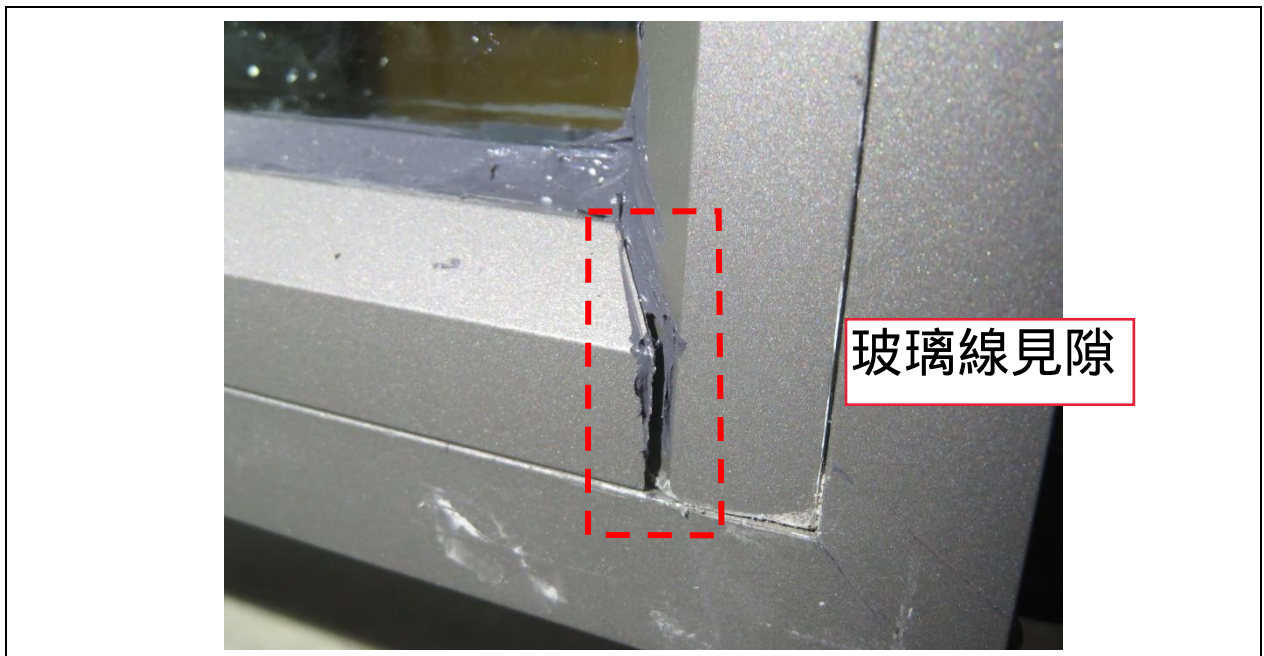

Photo #16

Observation (Window Sash)	Noticeable gap between glazing bead covers of sashes were observed.
Recommendation	Improvement in quality of fabrication as well as assembly is recommended.

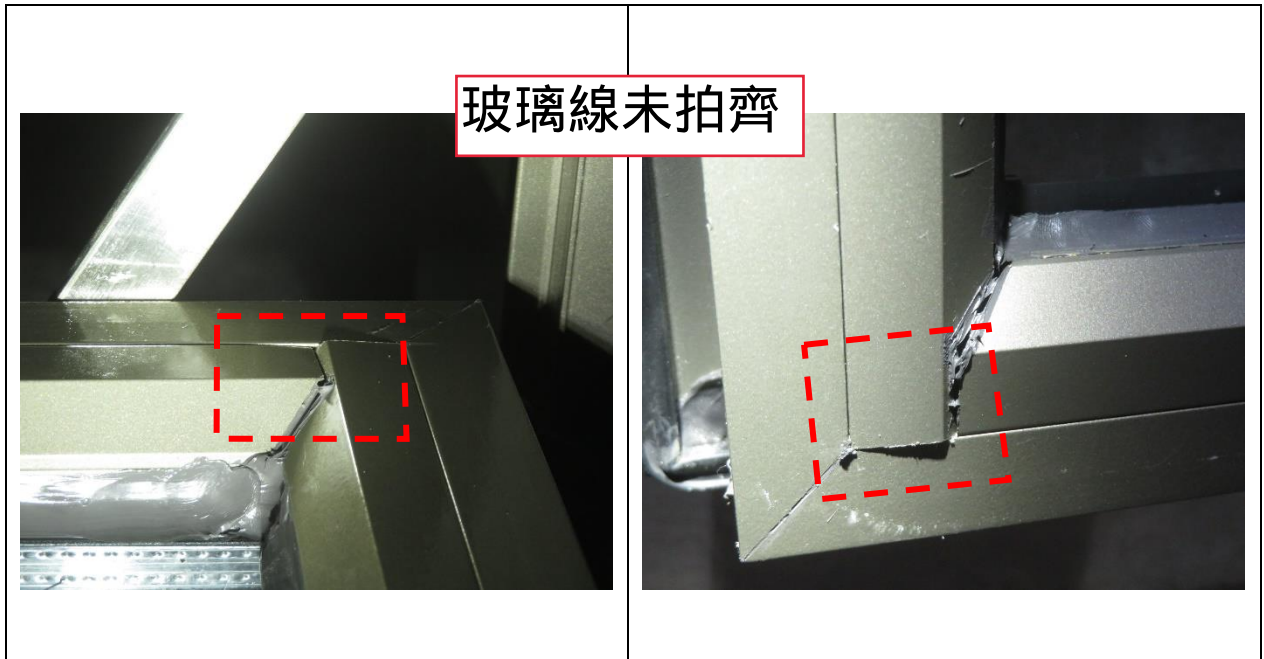

Photo #17

Observation (Window Sash)	Surfaces between glazing bead covers were not flush.
Recommendation	Rectification is required.

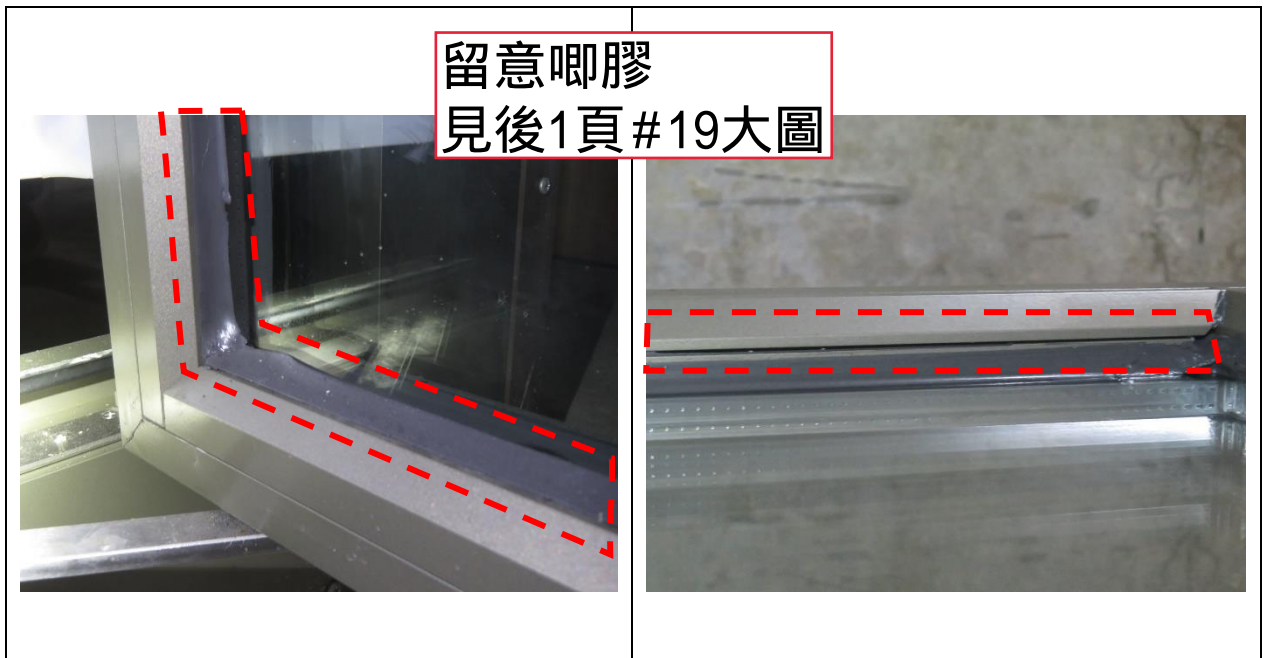

Photo #18

Observation (Window Sash)	Inconsistent glazing sealant of sashes (i.e. gaps between glazing beads and glazing bead covers were filled with sealant (LHS) or without sealant (RHS)). Please refer to Photo #19 for shop drawing detail.
Recommendation	Midi to clarify the inconsistency found. Rectification is required as per latest shop drawing.

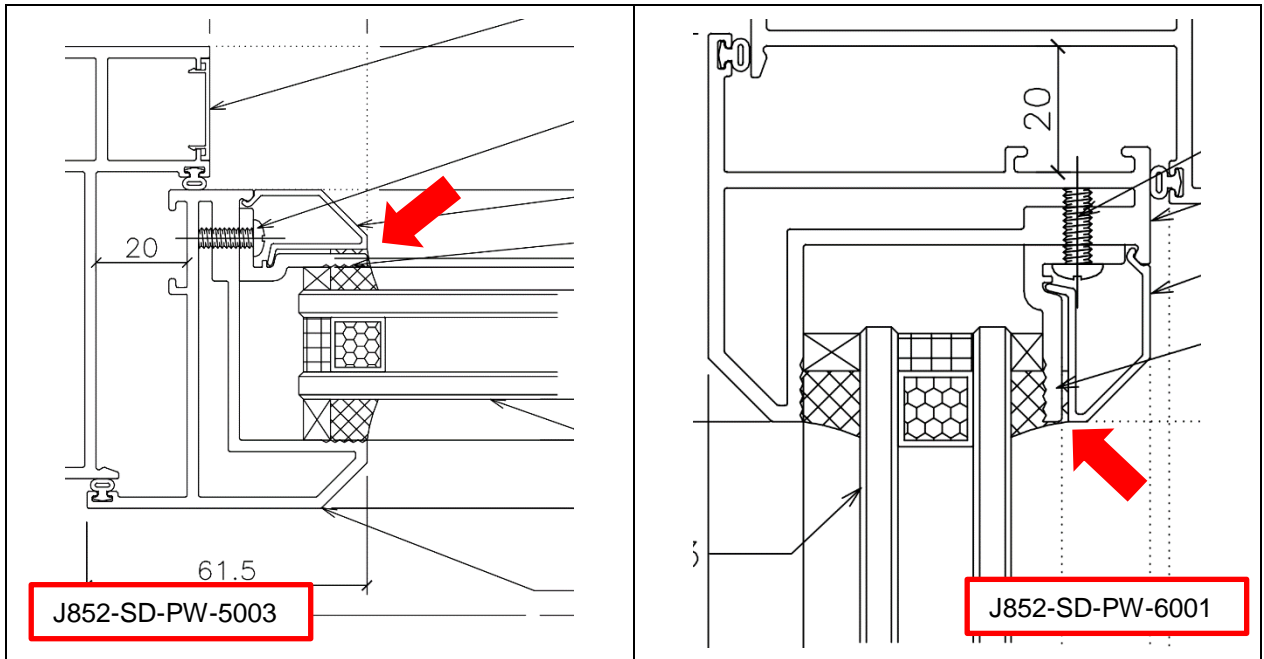

Photo #19

Observation	The above detail is extracted from latest shop drawings no. J852-SD-PW-5003 and J853-SD-PW-6001, sealant should be applied for the gap between glazing bead and its cover.
Recommendation	-

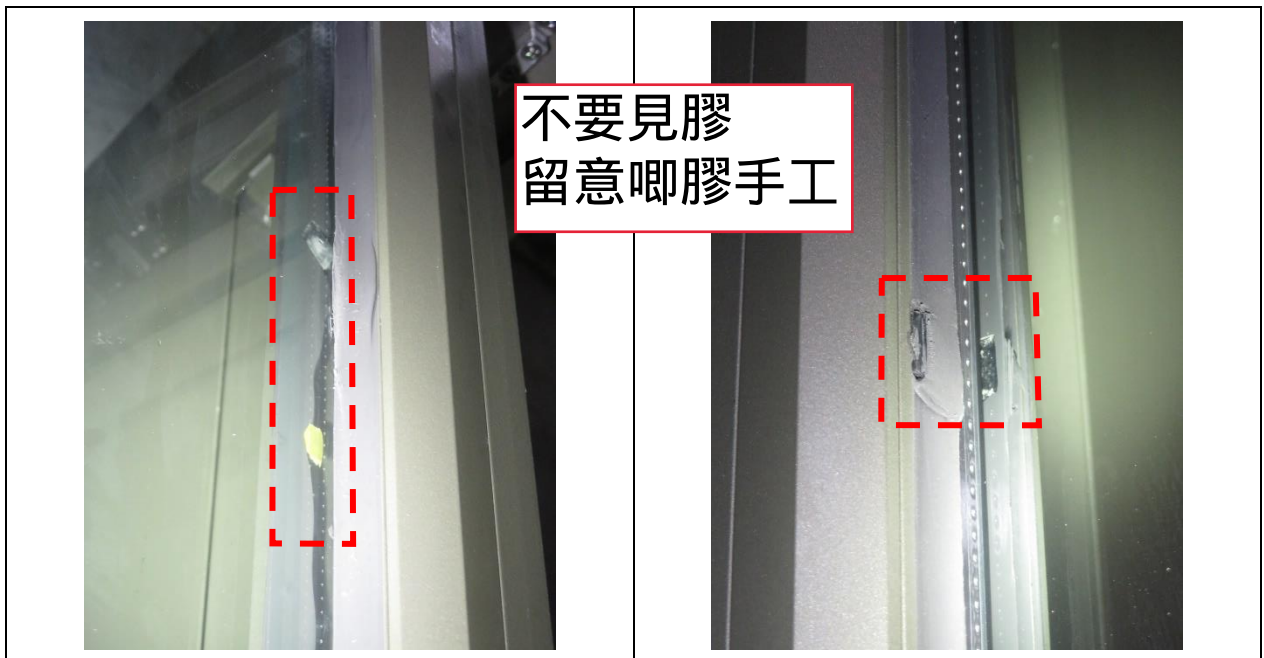

Photo #20

Observation (Window Sash)	Some spacers in the glazing sealant of sashes were noticeable.
Recommendation	Rectification is required.

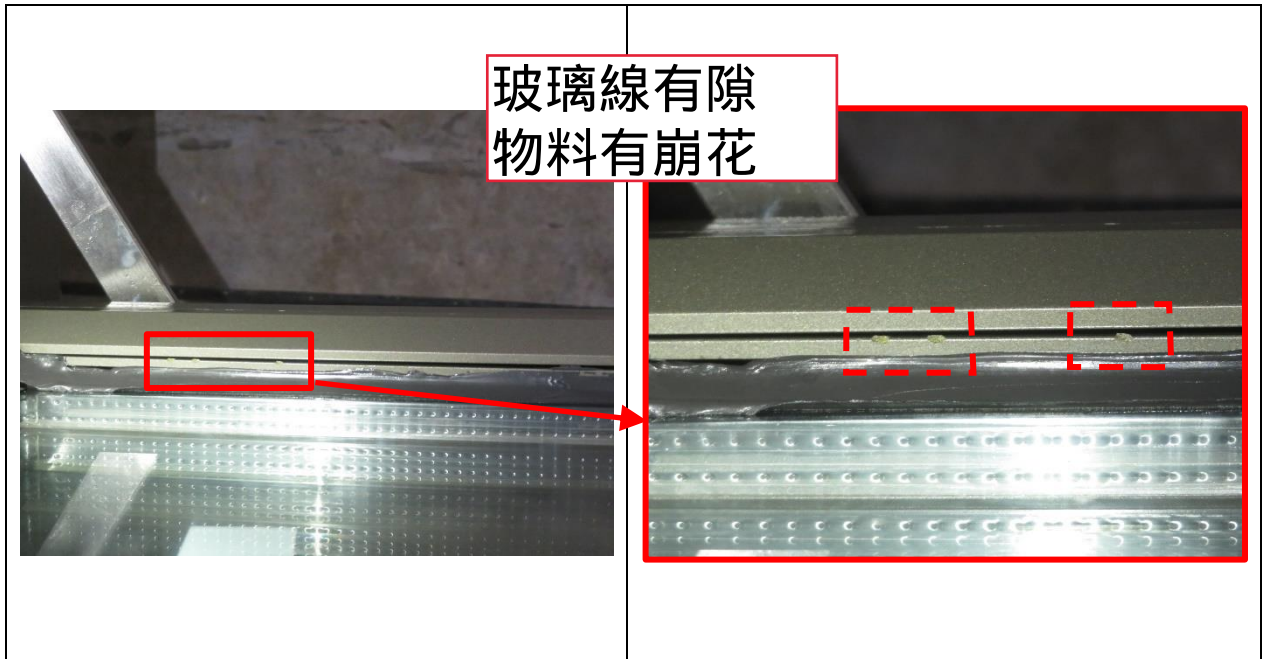

Photo #21

Observation (Window Sash)	LHS: Significant gap between glazing bead and glazing bead cover was noted. RHS: Damages were observed on the edge of glazing bead.
Recommendation	Please refer to Photo #16 for comment. Review of protection and handling of material are recommended.

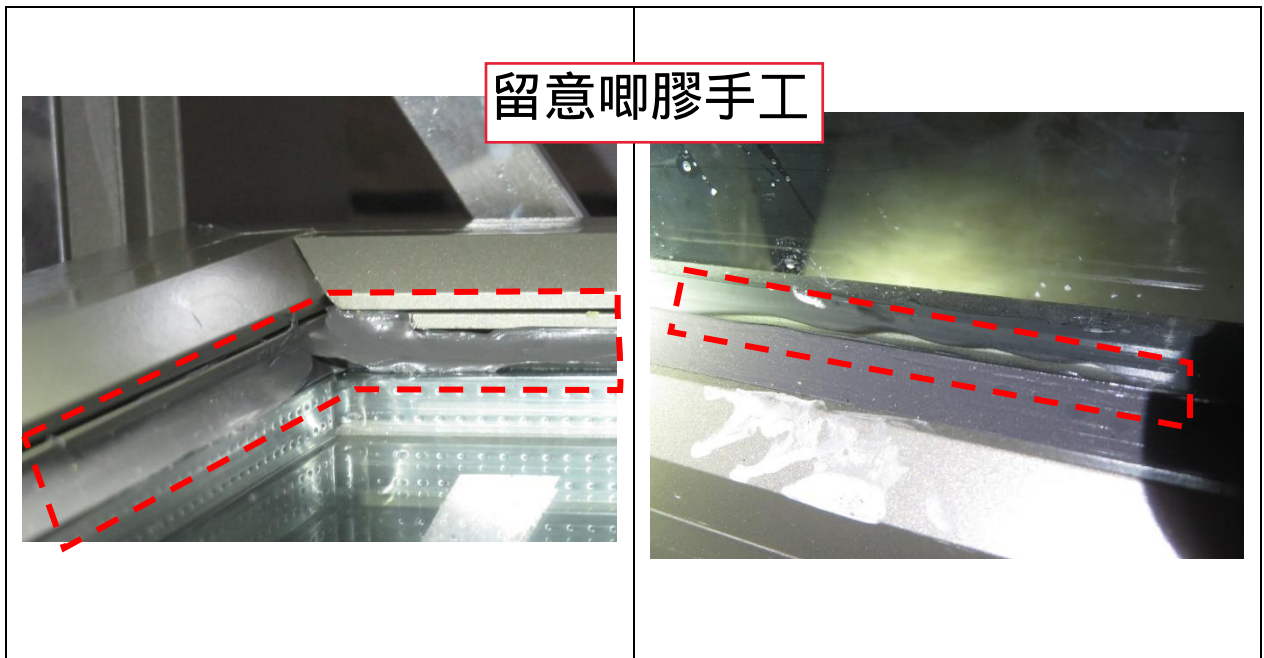

Photo #22

Observation (Window Sash)	Poor workmanship of glazing sealant was generally observed.
Recommendation	Rectification is required. Workmanship for sealant application should be improved.

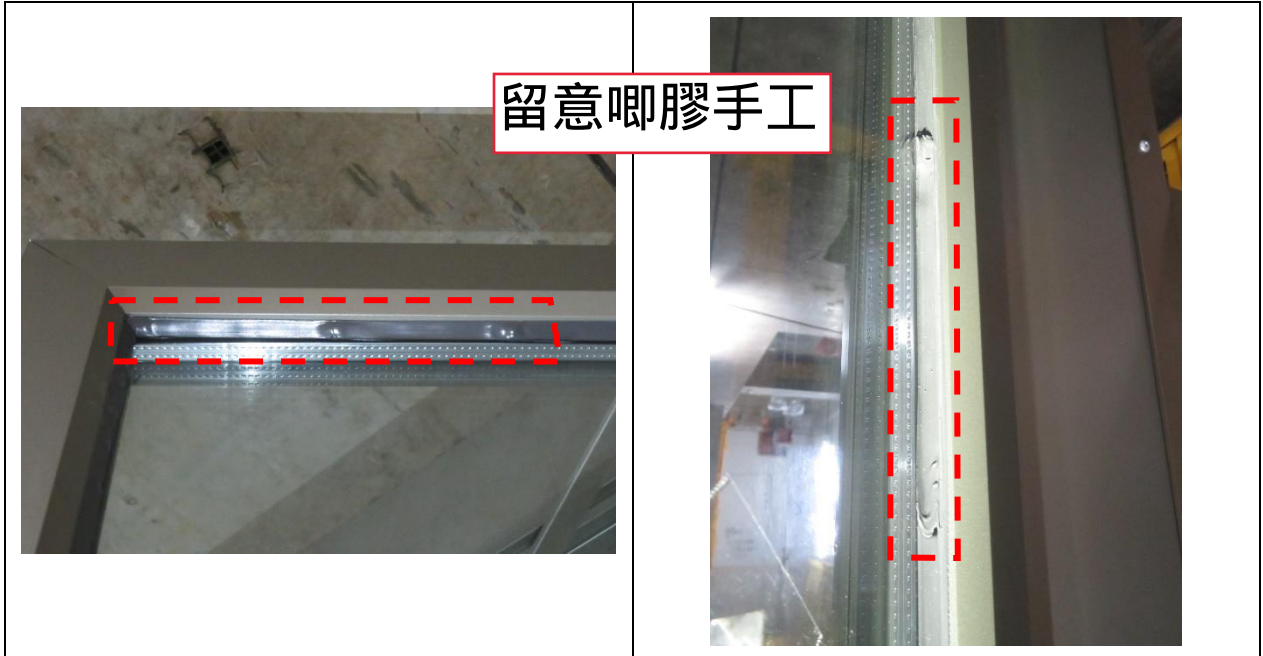

Photo #23

Observation (Window Sash)	Ditto.
Recommendation	Ditto.



Photo #24

Observation (Window Sash)	Pulling force required to close the window sash was around 5kg – 6.5kg (i.e. around 49N – 64N).
Recommendation	-

END

Site Memorandum

To : Gammon Engineering & Construction Co., Ltd Ref no : 1980045.1-SM-50019-00
Attn : Mr. Dick Yuen / Mr. Jackson Mok Date : 23 December 2020
From : Ms. Cosimo Wong / Mr. Neo Wong Required Reply Date: 14 days
Project : Proposed Residential Development at 139 – 147 Argyle Street, Kowloon
Subject : Façade Works – Site Inspection Report #21

Refer to site inspection regarding the captioned, we enclose herewith the Site Inspection Report #21 (14 – 18 Dec 2020) for your team to take necessary follow up actions and defects rectification immediately.

Best Regards,



Cosimo Wong

Distribution (by email)

SINO (PM)	-	Mr. Billy Tang / Mr. Jimmy Cheung	w/e
SINO (OSR)	-	Mr. Edwin Chow / Mr. Poon Tsz Kit	w/e
AGC	-	Ms. Grace Cheng / Mr. Raymond Ho / Mr. Eliot Chan	w/e
ARUP	-	Mr. Johnson Po / Mr. Jessy Zhang	w/e
WHS	-	Mr. Calvin Lee	w/e
Midi	-	Mr. Marco Tam / Ms. Bessie Lau	w/e
MFT Office	-	Mr. Brian Leung / Ms. Yoanna Chan	w/e

Proposed Residential Development at 139-147 Argyle Street, Kowloon

Site Inspection Report # 21

Inspection Date: 14th – 18th December 2020

1980045.1MFHK-SI-RPT-021-00

Submitted To

Pacific Shine Ltd.

Prepared By

Meinhardt Façade Technology (HK) Ltd

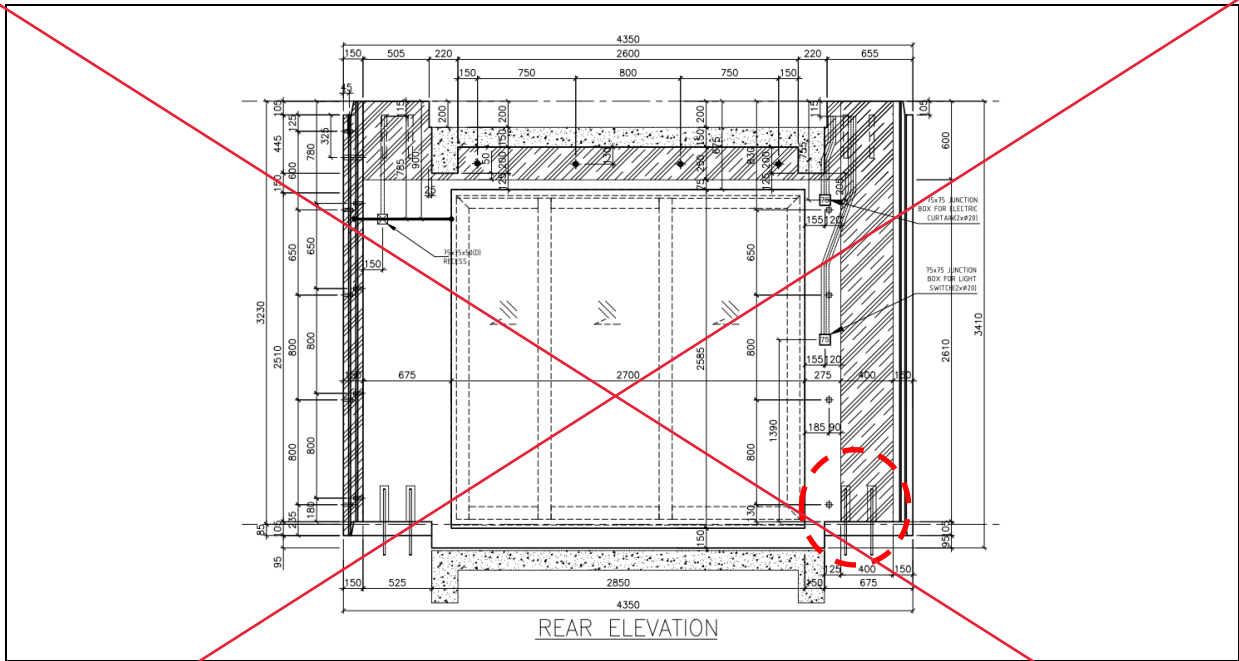

Photo #11

Observation
 (T1 1/F Flat A)

Shop drawing detail of PF-24, refer to submission ref. no. SD/A/002 (Rev.6).
 (Ref.: Site Memorandum #20009 issued on 18 Dec 2020)

Recommendation

Ditto.

顧問對師傅板的意見

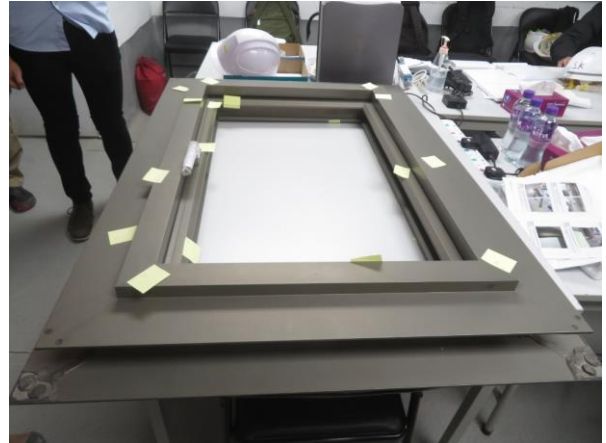

Photo #12

Observation
 (Alum Window)

Joint inspection for reviewing the rectification status of alum window sample was carried out with Pacific Shine (Sino), GEC and Midi on 16th Dec 2020. Please refer to Photo #13 – Photo #14 for observations.

Recommendation

-

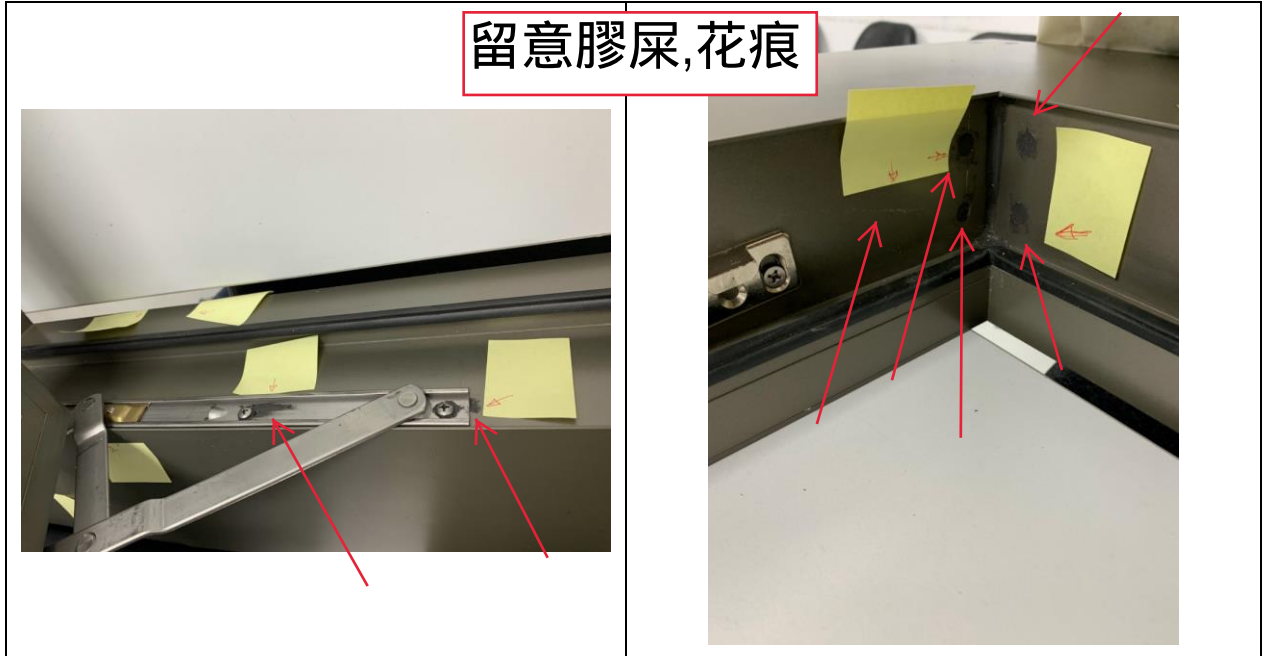

Photo #13

<p>Observation (Alum Window)</p>	<p>In general, no rectification works could be observed to address the observations/comments given by MFT during 1st joint inspection on 7th Aug 2020 (Details refer to report ref. no.: 1980045.1MFHK-SI-PRT-003-00, Photo #14 – Photo #36).</p>
<p>Recommendation</p>	<p>Midi is requested to address the observations/comments mentioned in the above inspection report case by case.</p>

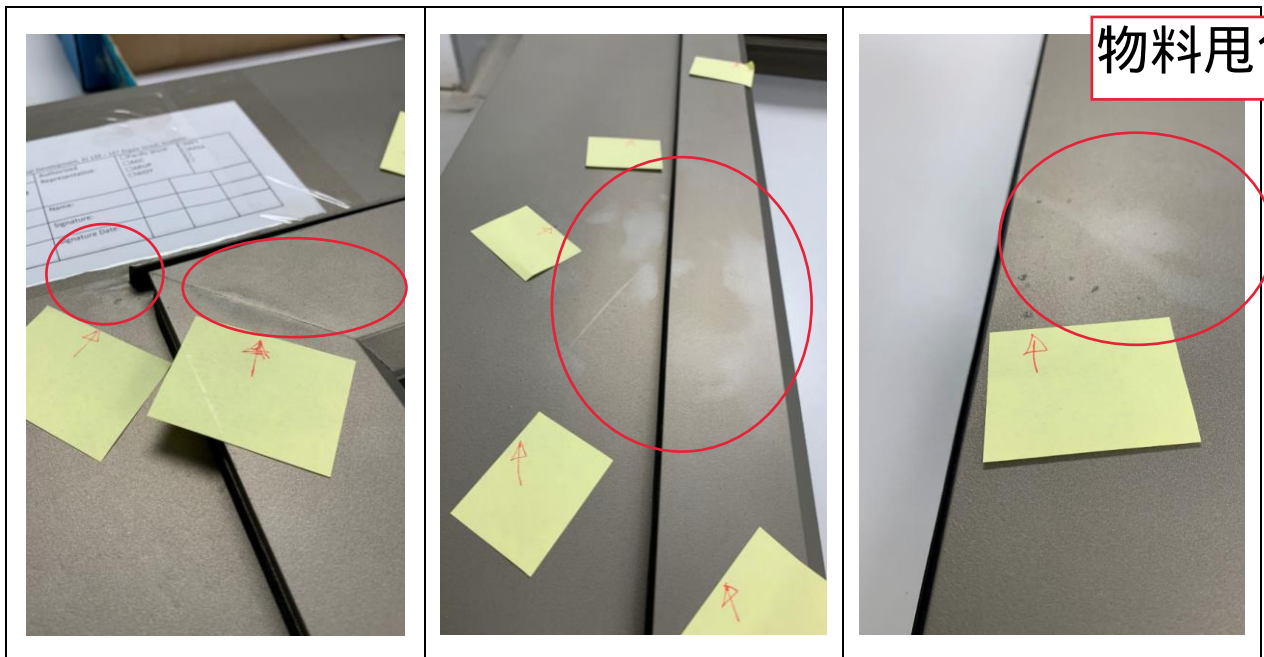

Photo #14

<p>Observation (Alum Window)</p>	<p>Further to Photo #13, noticeable touch-up works were also observed for the whole window sample especially at the locations with mitre joints.</p>
<p>Recommendation</p>	<p>Workmanship for touch-up works should be improved. Midi is required to rectify and resubmit the window sample immediately.</p>

END