



工程指示 / 要求簡箋(E.I.)

工程指示編號：EI / 2809 / 20

修改版次：-

工程編號：J - 852

工程名稱：亞皆老街中電

工程項目：大樓 偏林箱 圖紙 生產分判 查報價 要包拆圖

收件人：Maggie / 生統

發件人：Ant Yeung

日期：11/12/2020

要求提供 / 確認 事項：

- | | | |
|------------------------------------|-------------------------------------|-------------------------------|
| <input type="checkbox"/> 初步鋁料 B.M. | <input type="checkbox"/> 加工拆圖，然後生產 | <input type="checkbox"/> 尺寸表 |
| <input type="checkbox"/> 正式鋁料 B.M. | <input type="checkbox"/> 技術上資料 / 指示 | <input type="checkbox"/> 報價 |
| <input type="checkbox"/> 配件 B.M. | <input type="checkbox"/> 樣辦或貨品說明書 | <input type="checkbox"/> 分判合約 |
| <input type="checkbox"/> 其他：_____ | | |

請先報價 (要包拆圖)

內容：

請按附上大樓偏林箱圖紙，為生產分判 樣板層: T1,T2,T3, 5/F

T1 = 138 個

T2 = 137 個

厚度: 3mm

T3 = 153 個 合共 428 個偏林箱

優先生產 T3, 5/F 數量交現場樣板層安裝

T3 樣板層預 1 月中到貨，T1,T2 樣板層預 1 月尾到貨，

大貨 10 層一批，第一批預 2 月頭至中，實際日期到貨由地盤安排

分判：請先交樣板。 謝謝

請在 2020.12.19 前完成上列要求。

附：大圖+1 頁數量表

以上項目為：

原合約工程包 原合約工程加 / 減賬 新工程報價

原因：-

分發東莞各部門：

- | | | | |
|--|---|--|---|
| <input type="checkbox"/> 生產技術總監 <input type="checkbox"/> 連附件 | <input type="checkbox"/> 技術部 <input type="checkbox"/> 連附件 | <input type="checkbox"/> 生產部 <input type="checkbox"/> 連附件 | <input type="checkbox"/> 機械設計部 <input type="checkbox"/> 連附件 |
| <input type="checkbox"/> 採購部 <input type="checkbox"/> 連附件 | <input type="checkbox"/> 生產統籌部 <input type="checkbox"/> 連附件 | <input type="checkbox"/> 清&小羅 <input type="checkbox"/> 連附件 | |
| <input type="checkbox"/> 質檢部 <input type="checkbox"/> 連附件 | <input type="checkbox"/> 會計部 <input type="checkbox"/> 連附件 | <input type="checkbox"/> 報關組 <input type="checkbox"/> 連附件 | <input type="checkbox"/> 其他 <u>楊榮輝</u> <input type="checkbox"/> 連附件 |

分發其他分判：

(v) 水洪 連附件

分發香港各部門：

- | | | | |
|--|--|---|---|
| <input type="checkbox"/> 行政部 <input type="checkbox"/> 連附件 | <input type="checkbox"/> 會計部 <input type="checkbox"/> 連附件 | <input type="checkbox"/> 統籌部 <input type="checkbox"/> 連附件 | <input checked="" type="checkbox"/> 工程部地盤科文 <input type="checkbox"/> 連附件 <u>張</u> |
| <input checked="" type="checkbox"/> 採購部 <input type="checkbox"/> 連附件 | <input type="checkbox"/> QS 部 <input type="checkbox"/> 連附件 | <input type="checkbox"/> 維修部 <input type="checkbox"/> 連附件 | <input type="checkbox"/> 其他 _____ <input type="checkbox"/> 連附件 |

傳遞編號：

發件人簽署：Ant Yeung

HK 2845 / 20

項目經理簽署：Project Manager

J852 - Plenum Box數量

座數	單位	圖編號	樓層	數量
T1	A	T1A W4	1-20/F	17
T1	A	T1A W4	21/F	1
T1	A	T1A W5	1-20/F	17
T1	A	T1A W5	21/F	1
T1	C	T1C W6	1/F	1
T1	C	T1C W6	2-21/F	17
T1	B	T1B W5	1/F	1
T1	B	T1B W4	1/F	1
T1	B	T1B W5	2-21/F	17
T1	B	T1B W4	2-21/F	17
T1	B	T1B W8	1-21/F	18
T1	C	T1C W9	1-21/F	18
T1	A	T1A 22W14	22/F	1
T1	C	T1C 22W5	22/F	1
T1	A	T1A 22W6	22/F	1
T1	A	T1A 22W8	22/F	1
T1	A	T1A 22W9b	22/F	1
T1	A	T1A 23W14	23/F	1
T1	C	T1C 23W6	23/F	1
T1	A	T1A 23W6	23/F	1
T1	A	T1A 23W8	23/F	1
T1	A	T1A 23W7a	23/F	1
T1	A	T1A 23W14	23/F	1
T1	C	T1C 23W6	23/F	1
			總數	138

座數	單位	圖編號	樓層	數量
T2	C	T2C W6	1/F	1
T2	C	T2C W6	2-21/F	17
T2	A	T2A W4	1/F	1
T2	A	T2A W5	1/F	1
T2	A	T2A W4	2-21/F	17
T2	A	T2A W5	2-21/F	17
T2	B	T2B W5	1/F	1
T2	B	T2B W4	1/F	1
T2	B	T2B W5	2-21/F	17
T2	B	T2B W4	2-21/F	17
T2	A	T2A W8	1-21/F	18
T2	B	T2B W8	1-21/F	18
T2	C	T2C 22W	22/F	1
T2	A	T2A 22W	22/F	1
T2	A	T2A 22W	22/F	1
T2	B	T2B 22W	22/F	1
T2	B	T2B 22W	22/F	1
T2	A	T2A 22W	22/F	1
T2	B	T2B 22W	22/F	1
T2	A	T2A 23W	23/F	1
T2	B	T2B 22W	22/F	1
T2	A	T2A 23W	23/F	1
T2	A	T2A 23W	23/F	1
T2	A	T2A 23W	23/F	1
			總數	137

座數	單位	圖編號	樓層	數量
T3	A	T3A W4	1-21/F	18
T3	A	T3A W5	1-21/F	18
T3	C	T3C W6	1-21/F	18
T3	B	T3B W5	1-21/F	18
T3	B	T3B W4	1-21/F	18
T3	A	T3A W10	1-20/F	17
T3	B	T3B W8	1-21/F	18
T3	A	T3A W9	1-20/F	17
T3	A	T3A W9	21/F	1
T3	A	T3A 22W	22/F	1
T3	C	T3C 22W	22/F	1
T3	A	T3A 22W	22/F	1
T3	A	T3A 22W	22/F	1
T3	A	T3A 23W	23/F	1
T3	C	T3C 23W	23/F	1
T3	A	T3A 23W	23/F	1
T3	A	T3A 23W	23/F	1
T3	A	T3A 23W	23/F	1
			總數	153



**PROJECT : PROPOSED RESIDENTIAL DEVELOPMENT AT 139 - 147 ARGYLE STREET,
NKIL 6005, 6035 R.P., 6036 R.P., 6037 R.P. & 6038 R.P.**

2

**TITLE : Plenum box
SHOPDRAWING SUBMISSION**

DATE: 09-December - 2020

DRAWING SUBMISSION REGISTER

PROJECT: PROPOSED RESIDENTIAL DEVELOPMENT AT 139-147 ARGYLE STREET, NKIL 6006, 6035 R.P., 6036 R.P., TITLE: PLENUM BOX AT PRECAST FACADE AND IN-SITU WINDOW SHOPDRAWING SUBMISSION											SUBMISSION STATE (FOR B.D / A.S.D)			SUBMISSION STATE (FOR CLIENT / CONSULTANT)			SUBMISSION STATE (FOR ARCHITECT)			FABRICATION / CONSTRUCTION STATE						
	ISSUE	1	2									AP - APPROVED			AP - APPROVED			AP - APPROVED			ISSUE TO CHINA OFFICE		ISSUE TO SITE		ISSUE TO SUB-CONTRACTOR	
	DAY	15	8									AC - APPROVED SUB. TO CONDITION			AC - APPROVED SUB. TO CONDITION			AC - APPROVED SUB. TO CONDITION								
	MONTH	8	12									NA - NOT APPROVED			NA - NOT APPROVED			NA - NOT APPROVED								
	YEAR	20	20																							
DRAWING TITLE	DWG. NO.	REVISIONS										COMMENT DATE	REV.	STATE	COMMENT DATE	REV.	STATE	COMMENT DATE	REV.	STATE	REV.	DATE	REV.	DATE	REV.	DATE
COVER PAGE	J852-SD-PB-0000	-	A																							
DRAWING REGISTER	J852-SD-PB-0001	-	-																							
DRAWING REGISTER	J852-SD-PB-0002	-	-																							
DRAWING REGISTER	J852-SD-PB-0003	-	-																							
BUILDING ELEVATION FOR TOWER 1 · 2&3	J852-SD-PB-2001	-	-																							
BUILDING ELEVATION FOR TOWER 1 · 2&3	J852-SD-PB-2002	-	-																							
BUILDING ELEVATION FOR TOWER 1 · 2&3	J852-SD-PB-2003	-	-																							
PART PLAN OF TOWER 1 (1/F) FOR PLENUM BOX	J852-SD-PB-3001	-	A																							
PART PLAN OF TOWER 1 (2-21/F) FOR PLENUM BOX	J852-SD-PB-3002	-	A																							
PART PLAN OF TOWER 1 (22/F) FOR PLENUM BOX	J852-SD-PB-3003	-	A																							
PART PLAN OF TOWER 1 (23/F) FOR PLENUM BOX	J852-SD-PB-3004	-	-																							
PART PLAN OF TOWER 2 (1/F) FOR PLENUM BOX	J852-SD-PB-3005	-	-																							
PART PLAN OF TOWER 2 (2-21/F) FOR PLENUM BOX	J852-SD-PB-3006	-	-																							
PART PLAN OF TOWER 2 (22/F) FOR PLENUM BOX	J852-SD-PB-3007	-	A																							
PART PLAN OF TOWER 2 (23/F) FOR PLENUM BOX	J852-SD-PB-3008	-	-																							
PART PLAN OF TOWER 3 (1/F) FOR PLENUM BOX	J852-SD-PB-3009	-	A																							
PART PLAN OF TOWER 3 (2-21/F) FOR PLENUM BOX	J852-SD-PB-3010	-	A																							
PART PLAN OF TOWER 3 (23/F) FOR PLENUM BOX	J852-SD-PB-3011	-	-																							
PART PLAN OF TOWER 3 (23/F) FOR PLENUM BOX	J852-SD-PB-3012	-	-																							
PLENUM BOX SCHEDULE FOR ALUM. WINDOW AT PRECAST FACADE	J852-SD-PB-4101	-	A																							
PLENUM BOX SCHEDULE FOR ALUM. WINDOW AT PRECAST FACADE	J852-SD-PB-4101A		A																							
PLENUM BOX SCHEDULE FOR ALUM. WINDOW AT PRECAST FACADE	J852-SD-PB-4102	-	A																							
PLENUM BOX SCHEDULE FOR ALUM. WINDOW AT PRECAST FACADE	J852-SD-PB-4102A		A																							
PLENUM BOX SCHEDULE FOR ALUM. WINDOW AT PRECAST FACADE	J852-SD-PB-4103	-	A																							
PLENUM BOX SCHEDULE FOR ALUM. WINDOW AT PRECAST FACADE	J852-SD-PB-4103A	-	A																							
PLENUM BOX SCHEDULE FOR ALUM. WINDOW AT PRECAST FACADE	J852-SD-PB-4104	-	A																							
PLENUM BOX SCHEDULE FOR ALUM. WINDOW AT PRECAST FACADE	J852-SD-PB-4105	-	A																							
PLENUM BOX SCHEDULE FOR ALUM. WINDOW AT PRECAST FACADE	J852-SD-PB-4106	-	-																							
PLENUM BOX SCHEDULE FOR ALUM. WINDOW AT PRECAST FACADE	J852-SD-PB-4107	-	A																							
PLENUM BOX SCHEDULE FOR ALUM. WINDOW AT PRECAST FACADE	J852-SD-PB-4108	-	A																							
PLENUM BOX SCHEDULE FOR ALUM. WINDOW IN-SITU WINDOW	J852-SD-PB-4109	-	A																							
PLENUM BOX SCHEDULE FOR ALUM. WINDOW IN-SITU WINDOW	J852-SD-PB-4110	-	A																							
PLENUM BOX SCHEDULE FOR ALUM. WINDOW IN-SITU WINDOW	J852-SD-PB-4111	-	A																							
PLENUM BOX SCHEDULE FOR ALUM. WINDOW IN-SITU WINDOW	J852-SD-PB-4112	-	A																							
PLENUM BOX SCHEDULE FOR ALUM. WINDOW IN-SITU WINDOW	J852-SD-PB-4113	-	A																							
PLENUM BOX SCHEDULE FOR ALUM. WINDOW IN-SITU WINDOW	J852-SD-PB-4114		-																							
PLENUM BOX SCHEDULE FOR ALUM. WINDOW IN-SITU WINDOW	J852-SD-PB-4115		-																							
PLENUM BOX SCHEDULE FOR ALUM. WINDOW IN-SITU WINDOW	J852-SD-PB-4116		-																							
PLENUM BOX SCHEDULE FOR ALUM. WINDOW AT PRECAST FACADE	J852-SD-PB-4201	-	A																							
PLENUM BOX SCHEDULE FOR ALUM. WINDOW AT PRECAST FACADE	J852-SD-PB-4201A	-	A																							
PLENUM BOX SCHEDULE FOR ALUM. WINDOW AT PRECAST FACADE	J852-SD-PB-4202	-	A																							
PLENUM BOX SCHEDULE FOR ALUM. WINDOW AT PRECAST FACADE	J852-SD-PB-4202A	-	A																							
PLENUM BOX SCHEDULE FOR ALUM. WINDOW AT PRECAST FACADE	J852-SD-PB-4203	-	A																							
PLENUM BOX SCHEDULE FOR ALUM. WINDOW AT PRECAST FACADE	J852-SD-PB-4203A	-	A																							

IN-HOUSE DESIGN CHECKER



MIDI ALUMINIUM FABRICATOR LTD.
 Units 6-8, Sunray Industrial Centre, 1/F
 610 Cha Kwo Ling Road, Kowloon
 Tel:23489211-4 Fax:(852)27727666

DWG NO. : J852-SD-PB-0001 REV. : -

DRAWING SUBMISSION REGISTER

PROJECT: PROPOSED RESIDENTIAL DEVELOPMENT AT 139-147 ARGYLE STREET, NKIL 6006, 6035 R.P., 6036 R.P., TITLE: PLENUM BOX AT PRECAST FACADE AND IN-SITU WINDOW SHOPDRAWING SUBMISSION	DATE OF ISSUE										SUBMISSION STATE (FOR B.D / A.S.D)			SUBMISSION STATE (FOR CLIENT / CONSULTANT)			SUBMISSION STATE (FOR ARCHITECT)			FABRICATION / CONSTRUCTION STATE						
	ISSUE	1	2									AP - APPROVED			AP - APPROVED			AP - APPROVED			ISSUE TO CHINA OFFICE		ISSUE TO SITE		ISSUE TO SUB-CONTRACTOR	
	DAY	15	9								AC - APPROVED SUB. TO CONDITION			AC - APPROVED SUB. TO CONDITION			AC - APPROVED SUB. TO CONDITION									
	MONTH	8	12								NA - NOT APPROVED			NA - NOT APPROVED			NA - NOT APPROVED									
	YEAR	20	20																							
DRAWING TITLE	DWG. NO.	REVISIONS								COMMENT DATE	REV.	STATE	COMMENT DATE	REV.	STATE	COMMENT DATE	REV.	STATE	REV.	DATE	REV.	DATE	REV.	DATE		
PLENUM BOX SCHEDULE FOR ALUM. WINDOW AT PRECAST FACADE	J852-SD-PB-4204	-	A																							
PLENUM BOX SCHEDULE FOR ALUM. WINDOW AT PRECAST FACADE	J852-SD-PB-4205	-	A																							
PLENUM BOX SCHEDULE FOR ALUM. WINDOW AT PRECAST FACADE	J852-SD-PB-4206	-	A																							
PLENUM BOX SCHEDULE FOR ALUM. WINDOW AT PRECAST FACADE	J852-SD-PB-4207	-	A																							
PLENUM BOX SCHEDULE FOR ALUM. WINDOW AT PRECAST FACADE	J852-SD-PB-4208	-	A																							
PLENUM BOX SCHEDULE FOR ALUM. WINDOW AT PRECAST FACADE	J852-SD-PB-4209	-	A																							
PLENUM BOX SCHEDULE FOR ALUM. WINDOW AT PRECAST FACADE	J852-SD-PB-4210	-	A																							
PLENUM BOX SCHEDULE FOR ALUM. WINDOW AT PRECAST FACADE	J852-SD-PB-4211	-	A																							
PLENUM BOX SCHEDULE FOR ALUM. WINDOW IN-SITU WINDOW	J852-SD-PB-4212	-	A																							
PLENUM BOX SCHEDULE FOR ALUM. WINDOW IN-SITU WINDOW	J852-SD-PB-4213	-	A																							
PLENUM BOX SCHEDULE FOR ALUM. WINDOW IN-SITU WINDOW	J852-SD-PB-4214	-	A																							
PLENUM BOX SCHEDULE FOR ALUM. WINDOW IN-SITU WINDOW	J852-SD-PB-4215	-	A																							
PLENUM BOX SCHEDULE FOR ALUM. WINDOW AT PRECAST FACADE	J852-SD-PB-4301	-	A																							
PLENUM BOX SCHEDULE FOR ALUM. WINDOW AT PRECAST FACADE	J852-SD-PB-4302	-	A																							
PLENUM BOX SCHEDULE FOR ALUM. WINDOW AT PRECAST FACADE	J852-SD-PB-4303	-	A																							
PLENUM BOX SCHEDULE FOR ALUM. WINDOW AT PRECAST FACADE	J852-SD-PB-4304	-	A																							
PLENUM BOX SCHEDULE FOR ALUM. WINDOW AT PRECAST FACADE	J852-SD-PB-4305	-	A																							
PLENUM BOX SCHEDULE FOR ALUM. WINDOW AT PRECAST FACADE	J852-SD-PB-4306	-	A																							
PLENUM BOX SCHEDULE FOR ALUM. WINDOW AT PRECAST FACADE	J852-SD-PB-4307	-	-																							
PLENUM BOX SCHEDULE FOR ALUM. WINDOW AT PRECAST FACADE	J852-SD-PB-4308	-	-																							
PLENUM BOX SCHEDULE FOR ALUM. WINDOW IN-SITU WINDOW	J852-SD-PB-4309	-	A																							
PLENUM BOX SCHEDULE FOR ALUM. WINDOW IN-SITU WINDOW	J852-SD-PB-4310	-	A																							
PLENUM BOX SCHEDULE FOR ALUM. WINDOW IN-SITU WINDOW	J852-SD-PB-4311	-	A																							
PLENUM BOX SCHEDULE FOR ALUM. WINDOW IN-SITU WINDOW	J852-SD-PB-4312	-	A																							
PLENUM BOX SCHEDULE FOR ALUM. WINDOW IN-SITU WINDOW	J852-SD-PB-4313	-	A																							
PLENUM BOX SCHEDULE FOR ALUM. WINDOW IN-SITU WINDOW	J852-SD-PB-4314	-	A																							
PLENUM BOX SCHEDULE FOR ALUM. WINDOW IN-SITU WINDOW	J852-SD-PB-4315	-	-																							
PLENUM BOX SCHEDULE FOR ALUM. WINDOW IN-SITU WINDOW	J852-SD-PB-4316	-	-																							
PLENUM BOX SCHEDULE FOR ALUM. WINDOW IN-SITU WINDOW	J852-SD-PB-4317	-	-																							
PLENUM BOX SCHEDULE FOR ALUM. WINDOW IN-SITU WINDOW	J852-SD-PB-4318	-	-																							
PLENUM BOX FOR ALUM. WINDOW AT PRECAST FACADE AND IN-SITU WINDOW	J852-SD-PB-5001	-	A																							
PLENUM BOX FOR ALUM. WINDOW AT PRECAST FACADE AND IN-SITU WINDOW	J852-SD-PB-5001a	-	-																							
PLENUM BOX FOR ALUM. WINDOW AT PRECAST FACADE AND IN-SITU WINDOW	J852-SD-PB-5002	-	A																							
PLENUM BOX FOR ALUM. WINDOW AT PRECAST FACADE AND IN-SITU WINDOW	J852-SD-PB-5002a	-	-																							
PLENUM BOX FOR ALUM. WINDOW AT PRECAST FACADE AND IN-SITU WINDOW	J852-SD-PB-5002b	-	-																							
PLENUM BOX FOR ALUM. WINDOW AT PRECAST FACADE AND IN-SITU WINDOW	J852-SD-PB-5003	-	A																							
PLENUM BOX FOR ALUM. WINDOW AT PRECAST FACADE AND IN-SITU WINDOW	J852-SD-PB-5003a	-	-																							
PLENUM BOX FOR ALUM. WINDOW AT PRECAST FACADE AND IN-SITU WINDOW	J852-SD-PB-5004	-	A																							
PLENUM BOX FOR ALUM. WINDOW AT PRECAST FACADE AND IN-SITU WINDOW	J852-SD-PB-5005	-	A																							
PLENUM BOX FOR ALUM. WINDOW AT PRECAST FACADE AND IN-SITU WINDOW	J852-SD-PB-5006	-	-																							
PLENUM BOX FOR ALUM. WINDOW AT PRECAST FACADE AND IN-SITU WINDOW	J852-SD-PB-5007	-	-																							
PLENUM BOX FOR ALUM. WINDOW AT PRECAST FACADE AND IN-SITU WINDOW	J852-SD-PB-5008	-	-																							
PLENUM BOX FOR ALUM. WINDOW AT PRECAST FACADE AND IN-SITU WINDOW	J852-SD-PB-5009	-	-																							
PLENUM BOX FOR ALUM. WINDOW AT PRECAST FACADE AND IN-SITU WINDOW	J852-SD-PB-5010	-	-																							

IN-HOUSE DESIGN CHECKER



MIDI ALUMINIUM FABRICATOR LTD.
 Units 6-8, Sunray Industrial Centre, 1/F
 610 Cha Kwo Ling Road, Kowloon
 Tel:23489211-4 Fax:(852)27727666

DWG NO. : J852-SD-PB-0002 REV. : -

DRAWING SUBMISSION REGISTER

PROJECT: PROPOSED RESIDENTIAL DEVELOPMENT AT 139-147 ARGYLE STREET, NKIL 6006, 6035 R.P., 6036 R.P., TITLE: ALUMINIUM WINDOWS AT PRECAST FACADE SHOPDRAWING SUBMISSION	DATE OF ISSUE							SUBMISSION STATE (FOR B.D / A.S.D)			SUBMISSION STATE (FOR CLIENT / CONSULTANT)			SUBMISSION STATE (FOR ARCHITECT)			FABRICATION / CONSTRUCTION STATE					
	ISSUE	1	2					AP - APPROVED			AP - APPROVED			AP - APPROVED			ISSUE TO CHINA OFFICE		ISSUE TO SITE		ISSUE TO SUB-CONTRACTOR	
	DAY	15	9					AC - APPROVED SUB. TO CONDITION			AC - APPROVED SUB. TO CONDITION			AC - APPROVED SUB. TO CONDITION								
	MONTH	8	12					NA - NOT APPROVED			NA - NOT APPROVED			NA - NOT APPROVED								
YEAR	20	20																				

DRAWING TITLE	DWG. NO.	REVISIONS					COMMENT DATE	REV.	STATE	COMMENT DATE	REV.	STATE	COMMENT DATE	REV.	STATE	REV.	DATE	REV.	DATE	REV.	DATE
PLENUM BOX FOR ALUM. WINDOW AT PRECAST FACADE AND IN-SITU WINDOW	J852-SD-PB-5011	-																			
PLENUM BOX FOR ALUM. WINDOW AT PRECAST FACADE AND IN-SITU WINDOW	J852-SD-PB-5012	-																			
PLENUM BOX FOR ALUM. WINDOW AT PRECAST FACADE AND IN-SITU WINDOW	J852-SD-PB-5013	-																			
PLENUM BOX FOR ALUM. WINDOW AT PRECAST FACADE AND IN-SITU WINDOW	J852-SD-PB-5014	-																			
PLENUM BOX FOR ALUM. WINDOW AT PRECAST FACADE AND IN-SITU WINDOW	J852-SD-PB-6001	-	A																		
PLENUM BOX FOR ALUM. WINDOW AT PRECAST FACADE AND IN-SITU WINDOW	J852-SD-PB-6001a	-																			
PLENUM BOX FOR ALUM. WINDOW AT PRECAST FACADE AND IN-SITU WINDOW	J852-SD-PB-6001b	-																			
PLENUM BOX FOR ALUM. WINDOW AT PRECAST FACADE AND IN-SITU WINDOW	J852-SD-PB-6001c	-																			
PLENUM BOX FOR ALUM. WINDOW AT PRECAST FACADE AND IN-SITU WINDOW	J852-SD-PB-6002	-	A																		
PLENUM BOX FOR ALUM. WINDOW AT PRECAST FACADE AND IN-SITU WINDOW	J852-SD-PB-6003	-	A																		
PLENUM BOX FOR ALUM. WINDOW AT PRECAST FACADE AND IN-SITU WINDOW	J852-SD-PB-6004	-	A																		
PLENUM BOX FOR ALUM. WINDOW AT PRECAST FACADE AND IN-SITU WINDOW	J852-SD-PB-6005	-	A																		
PLENUM BOX FOR ALUM. WINDOW AT PRECAST FACADE AND IN-SITU WINDOW	J852-SD-PB-6006	-																			
PLENUM BOX FOR ALUM. WINDOW AT PRECAST FACADE AND IN-SITU WINDOW	J852-SD-PB-6007	-																			

IN-HOUSE DESIGN CHECKER



MIDI ALUMINIUM FABRICATOR LTD.
 Units 6-8, Sunray Industrial Centre, 1/F
 610 Cha Kwo Ling Road, Kowloon
 Tel:23489211-4 Fax:(852)27727666

DWG NO. : J852-SD-PW-0003 REV. : -

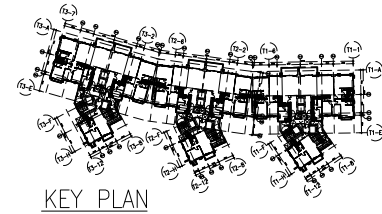

1 ELEVATION
SCALE 1:200

B.D. REF :

CLIENT :

ARCHITECT :
AGC DESIGN LTD

MAIN CONTRACTOR :
Gammon

STRUCTURAL ENGINEER :
ARUP

FAÇADE CONSULTANT:
MEINHARDT

NOTE :
1. ALL DIMENSIONS ARE IN mm.
2. ALL ELEVATIONS ARE VIEWED FROM OUTSIDE.
3. ALL DIMENSIONS TO BE VERIFIED ON SITE BEFORE FABRICATION.

LEGEND :
 (X1) — DETAIL MARK NO.
 (X001) — REFER SHEET NO.
 1. F.F.L. -- FINISHED FLOOR LEVEL
 2. S.F.L. -- STRUCTURAL FLOOR LEVEL
 3. (R) -- REVERSED DETAIL

NO.	DATE	REVISED	BY

JOB NO. : J-852
 PROJECT : PROPOSED RESIDENTIAL DEVELOPMENT AT 139 - 147 ARGYLE STREET, NKIL 6005, 6035 R.P., 6036 R.P., 6037 R.P. & 6038 R.P.

TITLE : BUILDING ELEVATION FOR TOWER 1, 2 & 3

DATE : 12-Dec-2019 SCALE : 1:200
 DRAWN BY : MN CHECKED BY : DW

美特鋁質有限公司
MIDI ALUMINIUM FABRICATOR LTD.
 Units 6-8, Sunray Industrial Centre, 1/F
 610 Cha Kwo Ling Road, Kowloon
 Tel:23489211-4 Fax:(852)2727666

DWG NO. : J852-SD-PB-2001 REV. : -

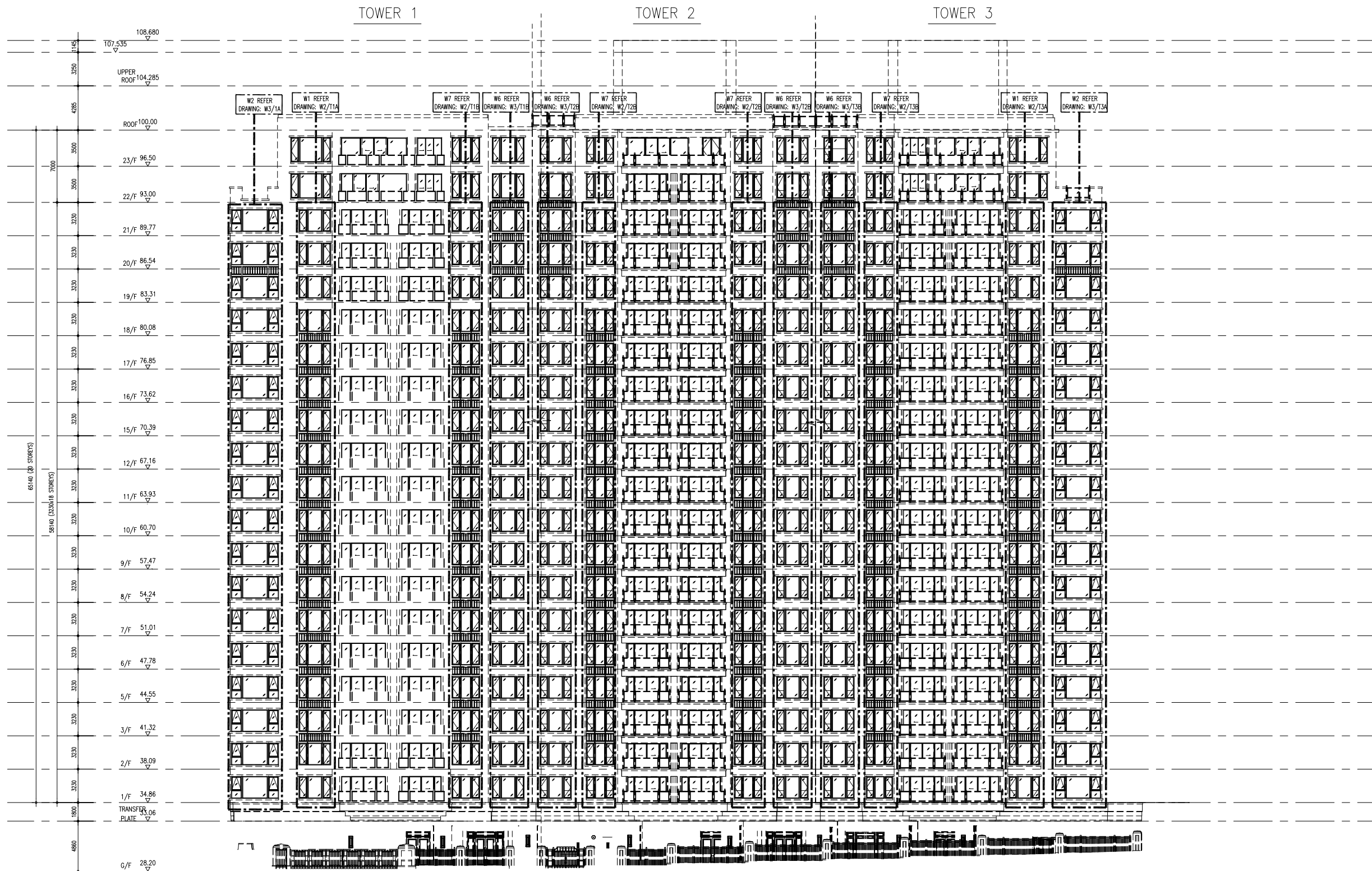
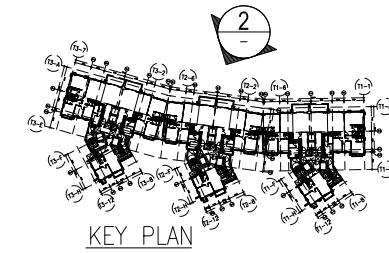

2 ELEVATION
SCALE 1:200
(4/F, 13/F & 14/F EXCLUDED)

B.D. REF :

CLIENT :

ARCHITECT :
AGC DESIGN LTD

MAIN CONTRACTOR :
Gammon

STRUCTURAL ENGINEER :
ARUP

FAÇADE CONSULTANT:
MEINHARDT

NOTE :
1. ALL DIMENSIONS ARE IN mm.
2. ALL ELEVATIONS ARE VIEWED FROM OUTSIDE.
3. ALL DIMENSIONS TO BE VERIFIED ON SITE BEFORE FABRICATION.

LEGEND :
 (X1) — DETAIL MARK NO.
 (X001) — REFER SHEET NO.
 1. F.F.L. — FINISHED FLOOR LEVEL
 2. S.F.L. — STRUCTURAL FLOOR LEVEL
 3. (R) — REVERSED DETAIL

NO.	DATE	REVISED	BY

JOB NO. : J-852
 PROJECT : PROPOSED RESIDENTIAL DEVELOPMENT AT 139 - 147 ARGYLE STREET, NKIL 6005, 6035 R.P., 6036 R.P., 6037 R.P. & 6038 R.P.

TITLE : BUILDING ELEVATION FOR TOWER 1, 2 & 3

DATE : 12-Dec-2019 SCALE : 1:200

DRAWN BY : MN CHECKED BY : DW

美特鋁質有限公司
MIDI ALUMINIUM FABRICATOR LTD.
 Units 6-8, Sunray Industrial Centre, 1/F
 610 Cha Kwo Ling Road, Kowloon
 Tel:23489211-4 Fax:(852)2727666

DWG NO. : J852-SD-PB-2002 REV. : -

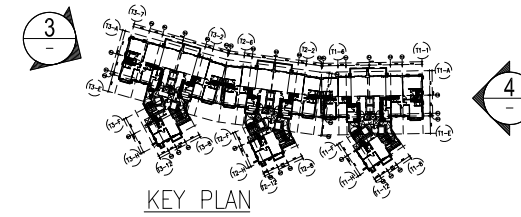

TOWER 3

TOWER 1

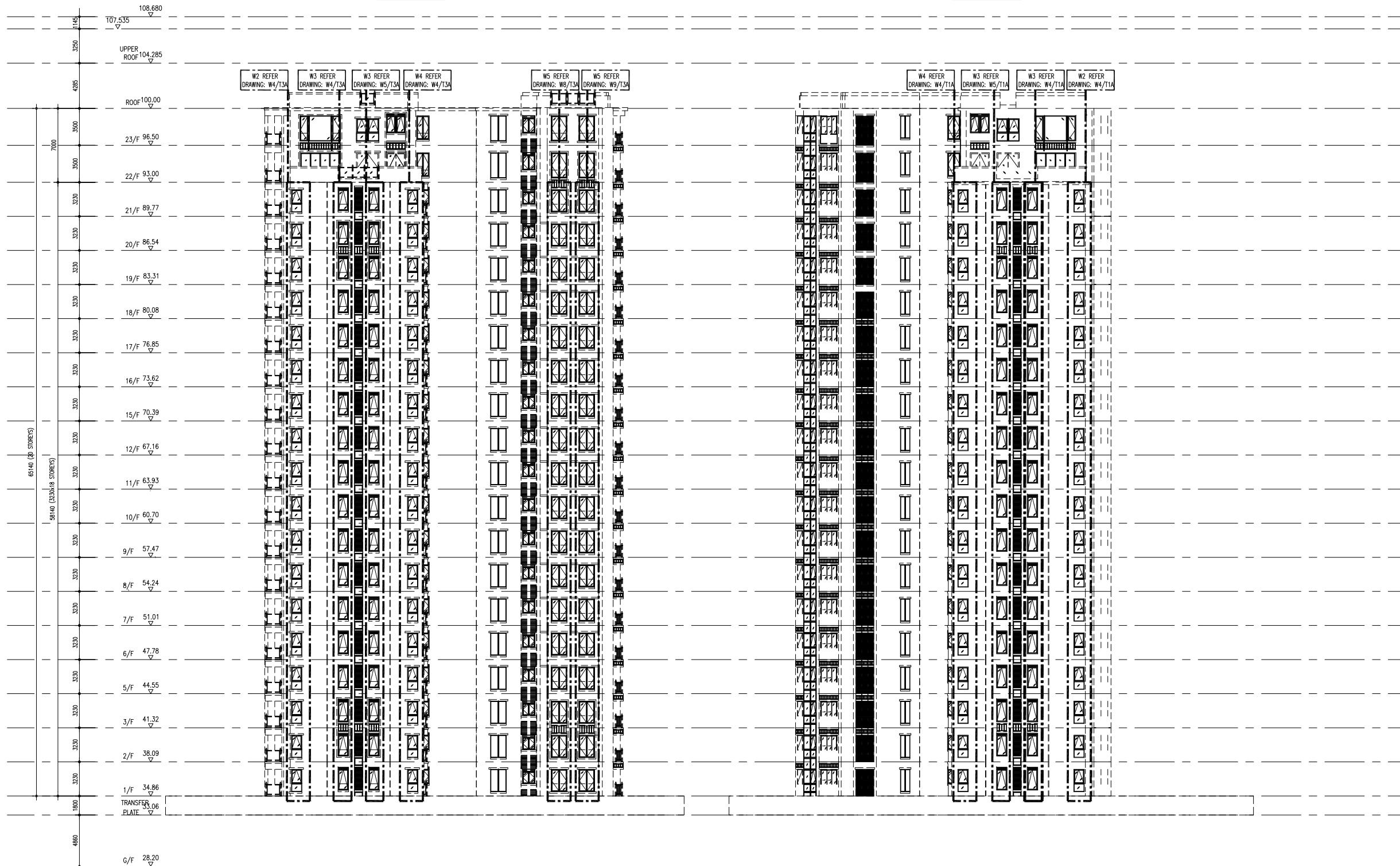

3 ELEVATION
SCALE 1:200
(4/F, 13/F & 14/F EXCLUDED)

4 ELEVATION
SCALE 1:200
(4/F, 13/F & 14/F EXCLUDED)

B.D. REF :

CLIENT :

ARCHITECT :
AGC DESIGN LTD
101, 102, 103, 104, 105, 106, 107, 108, 109, 110, 111, 112, 113, 114, 115, 116, 117, 118, 119, 120, 121, 122, 123, 124, 125, 126, 127, 128, 129, 130, 131, 132, 133, 134, 135, 136, 137, 138, 139, 140, 141, 142, 143, 144, 145, 146, 147, 148, 149, 150, 151, 152, 153, 154, 155, 156, 157, 158, 159, 160, 161, 162, 163, 164, 165, 166, 167, 168, 169, 170, 171, 172, 173, 174, 175, 176, 177, 178, 179, 180, 181, 182, 183, 184, 185, 186, 187, 188, 189, 190, 191, 192, 193, 194, 195, 196, 197, 198, 199, 200, 201, 202, 203, 204, 205, 206, 207, 208, 209, 210, 211, 212, 213, 214, 215, 216, 217, 218, 219, 220, 221, 222, 223, 224, 225, 226, 227, 228, 229, 230, 231, 232, 233, 234, 235, 236, 237, 238, 239, 240, 241, 242, 243, 244, 245, 246, 247, 248, 249, 250, 251, 252, 253, 254, 255, 256, 257, 258, 259, 260, 261, 262, 263, 264, 265, 266, 267, 268, 269, 270, 271, 272, 273, 274, 275, 276, 277, 278, 279, 280, 281, 282, 283, 284, 285, 286, 287, 288, 289, 290, 291, 292, 293, 294, 295, 296, 297, 298, 299, 300, 301, 302, 303, 304, 305, 306, 307, 308, 309, 310, 311, 312, 313, 314, 315, 316, 317, 318, 319, 320, 321, 322, 323, 324, 325, 326, 327, 328, 329, 330, 331, 332, 333, 334, 335, 336, 337, 338, 339, 340, 341, 342, 343, 344, 345, 346, 347, 348, 349, 350, 351, 352, 353, 354, 355, 356, 357, 358, 359, 360, 361, 362, 363, 364, 365, 366, 367, 368, 369, 370, 371, 372, 373, 374, 375, 376, 377, 378, 379, 380, 381, 382, 383, 384, 385, 386, 387, 388, 389, 390, 391, 392, 393, 394, 395, 396, 397, 398, 399, 400, 401, 402, 403, 404, 405, 406, 407, 408, 409, 410, 411, 412, 413, 414, 415, 416, 417, 418, 419, 420, 421, 422, 423, 424, 425, 426, 427, 428, 429, 430, 431, 432, 433, 434, 435, 436, 437, 438, 439, 440, 441, 442, 443, 444, 445, 446, 447, 448, 449, 450, 451, 452, 453, 454, 455, 456, 457, 458, 459, 460, 461, 462, 463, 464, 465, 466, 467, 468, 469, 470, 471, 472, 473, 474, 475, 476, 477, 478, 479, 480, 481, 482, 483, 484, 485, 486, 487, 488, 489, 490, 491, 492, 493, 494, 495, 496, 497, 498, 499, 500, 501, 502, 503, 504, 505, 506, 507, 508, 509, 510, 511, 512, 513, 514, 515, 516, 517, 518, 519, 520, 521, 522, 523, 524, 525, 526, 527, 528, 529, 530, 531, 532, 533, 534, 535, 536, 537, 538, 539, 540, 541, 542, 543, 544, 545, 546, 547, 548, 549, 550, 551, 552, 553, 554, 555, 556, 557, 558, 559, 560, 561, 562, 563, 564, 565, 566, 567, 568, 569, 570, 571, 572, 573, 574, 575, 576, 577, 578, 579, 580, 581, 582, 583, 584, 585, 586, 587, 588, 589, 590, 591, 592, 593, 594, 595, 596, 597, 598, 599, 600, 601, 602, 603, 604, 605, 606, 607, 608, 609, 610, 611, 612, 613, 614, 615, 616, 617, 618, 619, 620, 621, 622, 623, 624, 625, 626, 627, 628, 629, 630, 631, 632, 633, 634, 635, 636, 637, 638, 639, 640, 641, 642, 643, 644, 645, 646, 647, 648, 649, 650, 651, 652, 653, 654, 655, 656, 657, 658, 659, 660, 661, 662, 663, 664, 665, 666, 667, 668, 669, 670, 671, 672, 673, 674, 675, 676, 677, 678, 679, 680, 681, 682, 683, 684, 685, 686, 687, 688, 689, 690, 691, 692, 693, 694, 695, 696, 697, 698, 699, 700, 701, 702, 703, 704, 705, 706, 707, 708, 709, 710, 711, 712, 713, 714, 715, 716, 717, 718, 719, 720, 721, 722, 723, 724, 725, 726, 727, 728, 729, 730, 731, 732, 733, 734, 735, 736, 737, 738, 739, 740, 741, 742, 743, 744, 745, 746, 747, 748, 749, 750, 751, 752, 753, 754, 755, 756, 757, 758, 759, 760, 761, 762, 763, 764, 765, 766, 767, 768, 769, 770, 771, 772, 773, 774, 775, 776, 777, 778, 779, 780, 781, 782, 783, 784, 785, 786, 787, 788, 789, 790, 791, 792, 793, 794, 795, 796, 797, 798, 799, 800, 801, 802, 803, 804, 805, 806, 807, 808, 809, 810, 811, 812, 813, 814, 815, 816, 817, 818, 819, 820, 821, 822, 823, 824, 825, 826, 827, 828, 829, 830, 831, 832, 833, 834, 835, 836, 837, 838, 839, 840, 841, 842, 843, 844, 845, 846, 847, 848, 849, 850, 851, 852, 853, 854, 855, 856, 857, 858, 859, 860, 861, 862, 863, 864, 865, 866, 867, 868, 869, 870, 871, 872, 873, 874, 875, 876, 877, 878, 879, 880, 881, 882, 883, 884, 885, 886, 887, 888, 889, 890, 891, 892, 893, 894, 895, 896, 897, 898, 899, 900, 901, 902, 903, 904, 905, 906, 907, 908, 909, 910, 911, 912, 913, 914, 915, 916, 917, 918, 919, 920, 921, 922, 923, 924, 925, 926, 927, 928, 929, 930, 931, 932, 933, 934, 935, 936, 937, 938, 939, 940, 941, 942, 943, 944, 945, 946, 947, 948, 949, 950, 951, 952, 953, 954, 955, 956, 957, 958, 959, 960, 961, 962, 963, 964, 965, 966, 967, 968, 969, 970, 971, 972, 973, 974, 975, 976, 977, 978, 979, 980, 981, 982, 983, 984, 985, 986, 987, 988, 989, 990, 991, 992, 993, 994, 995, 996, 997, 998, 999, 1000

MAIN CONTRACTOR :
Gammon

STRUCTURAL ENGINEER :
ARUP

FACADE CONSULTANT:
MEINHARDT

NOTE :
1. ALL DIMENSIONS ARE IN mm.
2. ALL ELEVATIONS ARE VIEWED FROM OUTSIDE.
3. ALL DIMENSIONS TO BE VERIFIED ON SITE BEFORE FABRICATION.

LEGEND :
X1 --- DETAIL MARK NO.
X001 --- REFER SHEET NO.
1. F.F.L. --- FINISHED FLOOR LEVEL
2. S.F.L. --- STRUCTURAL FLOOR LEVEL
3. (R) --- REVERSED DETAIL

NO.	DATE	REVISED	BY

JOB NO. : J-852
PROJECT : PROPOSED RESIDENTIAL DEVELOPMENT AT 139 - 147 ARGYLE STREET, NKIL 6005, 6035 R.P., 6036 R.P., 6037 R.P. & 6038 R.P.

TITLE : BUILDING ELEVATION FOR TOWER 1, 2 & 3

DATE : 12-Dec-2019 SCALE : 1:200

DRAWN BY : MN CHECKED BY : DW

美特鋁質有限公司
MIDI ALUMINIUM FABRICATOR LTD.
Units 6-8, Sunray Industrial Centre, 1/F
610 Cha Kwo Ling Road, Kowloon
Tel:23489211-4 Fax:(852)2727666
DWG NO. : J852-SD-PB-2003 REV. : -

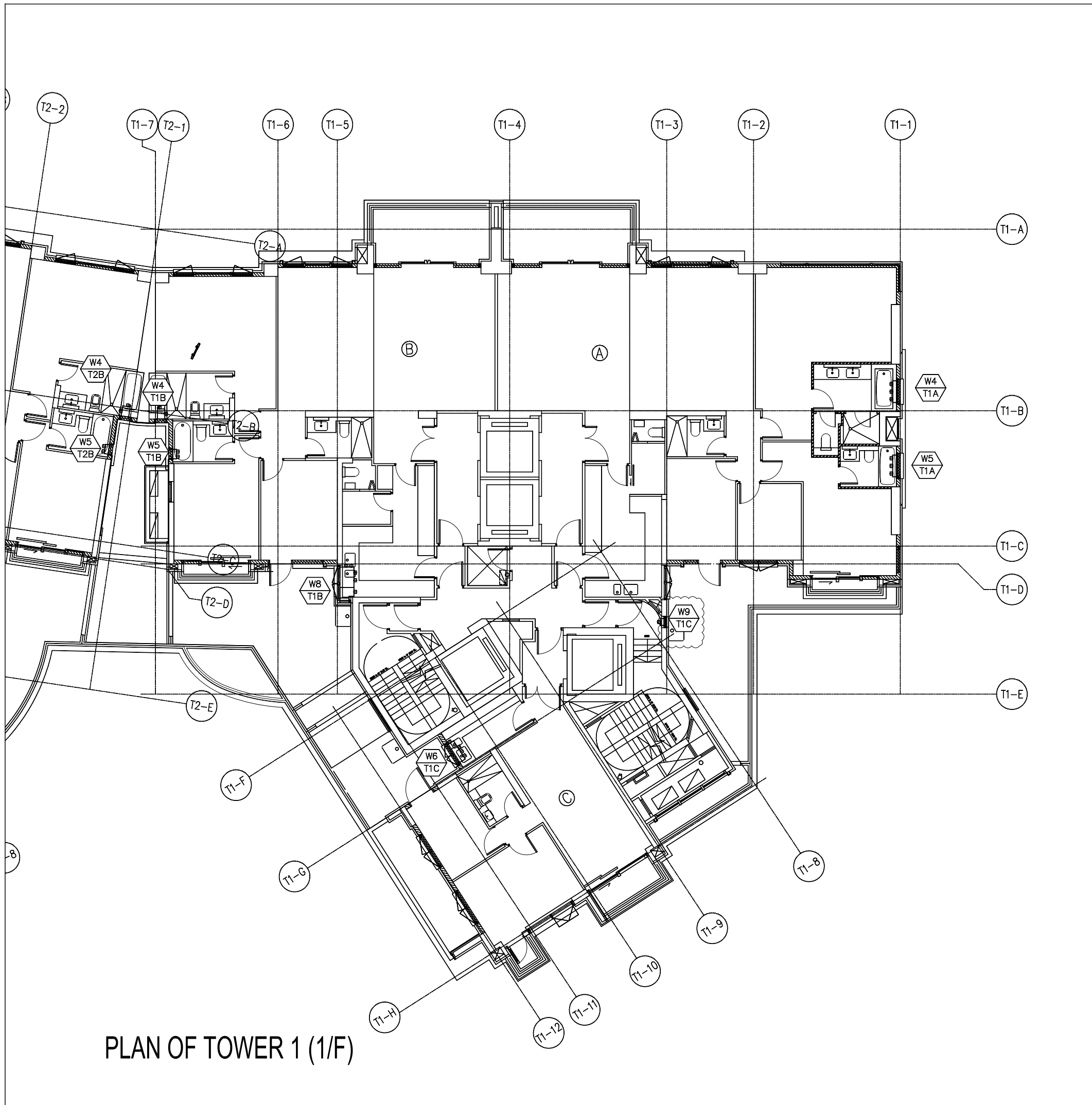

PLAN OF TOWER 1 (1/F)

B.D. REF :

CLIENT :

ARCHITECT :
AGC DESIGN LTD
AGC DESIGN LTD
 10/F, 100, Canton Road, 228, 230, 232, 234, 236, 238, 240, 242, 244, 246, 248, 250, 252, 254, 256, 258, 260, 262, 264, 266, 268, 270, 272, 274, 276, 278, 280, 282, 284, 286, 288, 290, 292, 294, 296, 298, 300, 302, 304, 306, 308, 310, 312, 314, 316, 318, 320, 322, 324, 326, 328, 330, 332, 334, 336, 338, 340, 342, 344, 346, 348, 350, 352, 354, 356, 358, 360, 362, 364, 366, 368, 370, 372, 374, 376, 378, 380, 382, 384, 386, 388, 390, 392, 394, 396, 398, 400, 402, 404, 406, 408, 410, 412, 414, 416, 418, 420, 422, 424, 426, 428, 430, 432, 434, 436, 438, 440, 442, 444, 446, 448, 450, 452, 454, 456, 458, 460, 462, 464, 466, 468, 470, 472, 474, 476, 478, 480, 482, 484, 486, 488, 490, 492, 494, 496, 498, 500, 502, 504, 506, 508, 510, 512, 514, 516, 518, 520, 522, 524, 526, 528, 530, 532, 534, 536, 538, 540, 542, 544, 546, 548, 550, 552, 554, 556, 558, 560, 562, 564, 566, 568, 570, 572, 574, 576, 578, 580, 582, 584, 586, 588, 590, 592, 594, 596, 598, 600, 602, 604, 606, 608, 610, 612, 614, 616, 618, 620, 622, 624, 626, 628, 630, 632, 634, 636, 638, 640, 642, 644, 646, 648, 650, 652, 654, 656, 658, 660, 662, 664, 666, 668, 670, 672, 674, 676, 678, 680, 682, 684, 686, 688, 690, 692, 694, 696, 698, 700, 702, 704, 706, 708, 710, 712, 714, 716, 718, 720, 722, 724, 726, 728, 730, 732, 734, 736, 738, 740, 742, 744, 746, 748, 750, 752, 754, 756, 758, 760, 762, 764, 766, 768, 770, 772, 774, 776, 778, 780, 782, 784, 786, 788, 790, 792, 794, 796, 798, 800, 802, 804, 806, 808, 810, 812, 814, 816, 818, 820, 822, 824, 826, 828, 830, 832, 834, 836, 838, 840, 842, 844, 846, 848, 850, 852, 854, 856, 858, 860, 862, 864, 866, 868, 870, 872, 874, 876, 878, 880, 882, 884, 886, 888, 890, 892, 894, 896, 898, 900, 902, 904, 906, 908, 910, 912, 914, 916, 918, 920, 922, 924, 926, 928, 930, 932, 934, 936, 938, 940, 942, 944, 946, 948, 950, 952, 954, 956, 958, 960, 962, 964, 966, 968, 970, 972, 974, 976, 978, 980, 982, 984, 986, 988, 990, 992, 994, 996, 998, 1000

MAIN CONTRACTOR :
Gammon

STRUCTURAL ENGINEER :
ARUP

FACADE CONSULTANT :
MEINHARDT

NOTE :
 1. ALL DIMENSIONS ARE IN mm.
 2. ALL ELEVATIONS ARE VIEWED FROM OUTSIDE.
 3. ALL DIMENSIONS TO BE VERIFIED ON SITE BEFORE FABRICATION.

LEGEND :
 X1 — DETAIL MARK NO.
 X001 — REFER SHEET NO.
 1. F.F.L. -- FINISHED FLOOR LEVEL
 2. S.F.L. -- STRUCTURAL FLOOR LEVEL
 3. /R -- REVERSED DETAIL

No.	DATE	REVISION	SUBJECT TO ARCH.COMMENT	BY
A	07/11/2020		REVISION SUBJECT TO ARCH.COMMENT	ivon

JOB NO. : J-852
 PROJECT : PROPOSED RESIDENTIAL DEVELOPMENT AT 139 - 147 ARGYLE STREET, NKIL 6005, 6035 R.P., 6036 R.P., 6037 R.P. & 6038 R.P.

TITLE : PART PLAN OF TOWER 1 (1/F)

DATE : 12-Dec-2019 SCALE : 1:150

DRAWN BY : MN CHECKED BY : DW

美特鋁質有限公司
MIDI ALUMINIUM FABRICATOR LTD.
 Units 6-8, Sunray Industrial Centre, 1/F
 610 Cha Kwo Ling Road, Kowloon
 Tel: 23489211-4 Fax: (852)2727666

DWG NO. : J852-SD-PB-3001 REV. : A

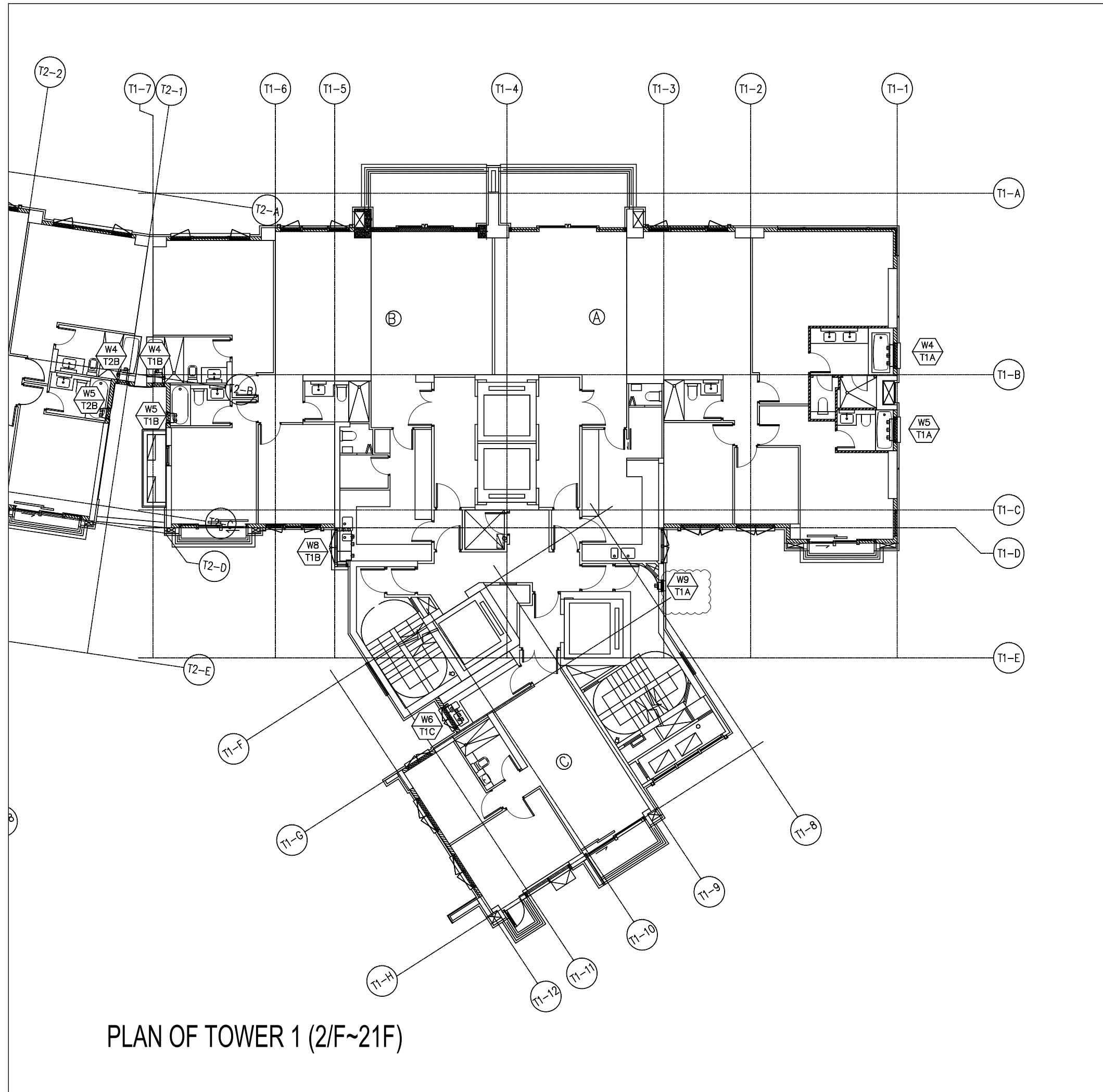

PLAN OF TOWER 1 (2/F~21F)

B.D. REF :

CLIENT :

ARCHITECT :
AGC DESIGN LTD
101, 102, 103, 104, 105, 106, 107, 108, 109, 110, 111, 112, 113, 114, 115, 116, 117, 118, 119, 120, 121, 122, 123, 124, 125, 126, 127, 128, 129, 130, 131, 132, 133, 134, 135, 136, 137, 138, 139, 140, 141, 142, 143, 144, 145, 146, 147, 148, 149, 150, 151, 152, 153, 154, 155, 156, 157, 158, 159, 160, 161, 162, 163, 164, 165, 166, 167, 168, 169, 170, 171, 172, 173, 174, 175, 176, 177, 178, 179, 180, 181, 182, 183, 184, 185, 186, 187, 188, 189, 190, 191, 192, 193, 194, 195, 196, 197, 198, 199, 200, 201, 202, 203, 204, 205, 206, 207, 208, 209, 210, 211, 212, 213, 214, 215, 216, 217, 218, 219, 220, 221, 222, 223, 224, 225, 226, 227, 228, 229, 230, 231, 232, 233, 234, 235, 236, 237, 238, 239, 240, 241, 242, 243, 244, 245, 246, 247, 248, 249, 250, 251, 252, 253, 254, 255, 256, 257, 258, 259, 260, 261, 262, 263, 264, 265, 266, 267, 268, 269, 270, 271, 272, 273, 274, 275, 276, 277, 278, 279, 280, 281, 282, 283, 284, 285, 286, 287, 288, 289, 290, 291, 292, 293, 294, 295, 296, 297, 298, 299, 300, 301, 302, 303, 304, 305, 306, 307, 308, 309, 310, 311, 312, 313, 314, 315, 316, 317, 318, 319, 320, 321, 322, 323, 324, 325, 326, 327, 328, 329, 330, 331, 332, 333, 334, 335, 336, 337, 338, 339, 340, 341, 342, 343, 344, 345, 346, 347, 348, 349, 350, 351, 352, 353, 354, 355, 356, 357, 358, 359, 360, 361, 362, 363, 364, 365, 366, 367, 368, 369, 370, 371, 372, 373, 374, 375, 376, 377, 378, 379, 380, 381, 382, 383, 384, 385, 386, 387, 388, 389, 390, 391, 392, 393, 394, 395, 396, 397, 398, 399, 400, 401, 402, 403, 404, 405, 406, 407, 408, 409, 410, 411, 412, 413, 414, 415, 416, 417, 418, 419, 420, 421, 422, 423, 424, 425, 426, 427, 428, 429, 430, 431, 432, 433, 434, 435, 436, 437, 438, 439, 440, 441, 442, 443, 444, 445, 446, 447, 448, 449, 450, 451, 452, 453, 454, 455, 456, 457, 458, 459, 460, 461, 462, 463, 464, 465, 466, 467, 468, 469, 470, 471, 472, 473, 474, 475, 476, 477, 478, 479, 480, 481, 482, 483, 484, 485, 486, 487, 488, 489, 490, 491, 492, 493, 494, 495, 496, 497, 498, 499, 500, 501, 502, 503, 504, 505, 506, 507, 508, 509, 510, 511, 512, 513, 514, 515, 516, 517, 518, 519, 520, 521, 522, 523, 524, 525, 526, 527, 528, 529, 530, 531, 532, 533, 534, 535, 536, 537, 538, 539, 540, 541, 542, 543, 544, 545, 546, 547, 548, 549, 550, 551, 552, 553, 554, 555, 556, 557, 558, 559, 560, 561, 562, 563, 564, 565, 566, 567, 568, 569, 570, 571, 572, 573, 574, 575, 576, 577, 578, 579, 580, 581, 582, 583, 584, 585, 586, 587, 588, 589, 590, 591, 592, 593, 594, 595, 596, 597, 598, 599, 600, 601, 602, 603, 604, 605, 606, 607, 608, 609, 610, 611, 612, 613, 614, 615, 616, 617, 618, 619, 620, 621, 622, 623, 624, 625, 626, 627, 628, 629, 630, 631, 632, 633, 634, 635, 636, 637, 638, 639, 640, 641, 642, 643, 644, 645, 646, 647, 648, 649, 650, 651, 652, 653, 654, 655, 656, 657, 658, 659, 660, 661, 662, 663, 664, 665, 666, 667, 668, 669, 670, 671, 672, 673, 674, 675, 676, 677, 678, 679, 680, 681, 682, 683, 684, 685, 686, 687, 688, 689, 690, 691, 692, 693, 694, 695, 696, 697, 698, 699, 700, 701, 702, 703, 704, 705, 706, 707, 708, 709, 710, 711, 712, 713, 714, 715, 716, 717, 718, 719, 720, 721, 722, 723, 724, 725, 726, 727, 728, 729, 730, 731, 732, 733, 734, 735, 736, 737, 738, 739, 740, 741, 742, 743, 744, 745, 746, 747, 748, 749, 750, 751, 752, 753, 754, 755, 756, 757, 758, 759, 760, 761, 762, 763, 764, 765, 766, 767, 768, 769, 770, 771, 772, 773, 774, 775, 776, 777, 778, 779, 780, 781, 782, 783, 784, 785, 786, 787, 788, 789, 790, 791, 792, 793, 794, 795, 796, 797, 798, 799, 800, 801, 802, 803, 804, 805, 806, 807, 808, 809, 810, 811, 812, 813, 814, 815, 816, 817, 818, 819, 820, 821, 822, 823, 824, 825, 826, 827, 828, 829, 830, 831, 832, 833, 834, 835, 836, 837, 838, 839, 840, 841, 842, 843, 844, 845, 846, 847, 848, 849, 850, 851, 852, 853, 854, 855, 856, 857, 858, 859, 860, 861, 862, 863, 864, 865, 866, 867, 868, 869, 870, 871, 872, 873, 874, 875, 876, 877, 878, 879, 880, 881, 882, 883, 884, 885, 886, 887, 888, 889, 890, 891, 892, 893, 894, 895, 896, 897, 898, 899, 900, 901, 902, 903, 904, 905, 906, 907, 908, 909, 910, 911, 912, 913, 914, 915, 916, 917, 918, 919, 920, 921, 922, 923, 924, 925, 926, 927, 928, 929, 930, 931, 932, 933, 934, 935, 936, 937, 938, 939, 940, 941, 942, 943, 944, 945, 946, 947, 948, 949, 950, 951, 952, 953, 954, 955, 956, 957, 958, 959, 960, 961, 962, 963, 964, 965, 966, 967, 968, 969, 970, 971, 972, 973, 974, 975, 976, 977, 978, 979, 980, 981, 982, 983, 984, 985, 986, 987, 988, 989, 990, 991, 992, 993, 994, 995, 996, 997, 998, 999, 1000

MAIN CONTRACTOR :
Gammon

STRUCTURAL ENGINEER :
ARUP

FACADE CONSULTANT:
MEINHARDT

NOTE :

1. ALL DIMENSIONS ARE IN mm.
2. ALL ELEVATIONS ARE VIEWED FROM OUTSIDE.
3. ALL DIMENSIONS TO BE VERIFIED ON SITE BEFORE FABRICATION.

LEGEND :

x1 — DETAIL MARK NO.
 x001 — REFER SHEET NO.

1. F.F.L. -- FINISHED FLOOR LEVEL
2. S.F.L. -- STRUCTURAL FLOOR LEVEL
3. (R) -- REVERSED DETAIL

NO.	DATE	REVISION	BY
A	07/11/2020	REVISION SUBJECT TO ARCH.COMMENT	lvart

JOB NO. : J-852

PROJECT :
 PROPOSED RESIDENTIAL DEVELOPMENT
 AT 139 - 147 ARGYLE STREET,
 NKIL 6005, 6035 R.P., 6036 R.P.,
 6037 R.P. & 6038 R.P.

TITLE :
 PART PLAN OF
 TOWER 1 (2-21/F)

DATE : 12-Dec-2019 SCALE : 1:150

DRAWN BY : MN CHECKED BY : DW

美特鋁質有限公司
MIDI ALUMINIUM FABRICATOR LTD.
 Units 6-8, Sunray Industrial Centre, 1/F
 610 Cha Kwo Ling Road, Kowloon
 Tel: 23489211-4 Fax: (852)2727666

DWG NO. : J852-SD-PB-3002 REV. : A

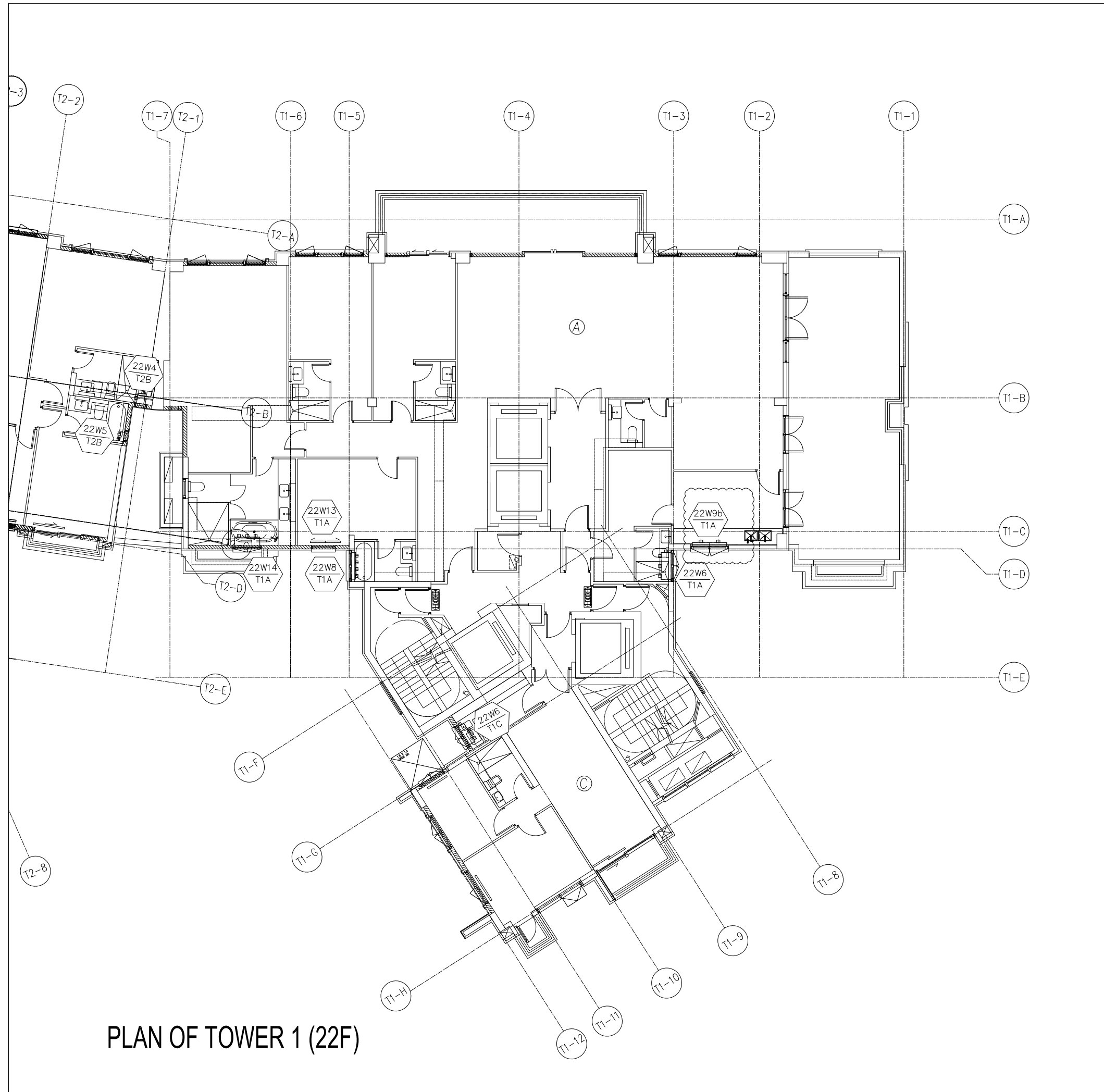

PLAN OF TOWER 1 (22F)

B.D. REF :

CLIENT :

ARCHITECT :
AGC DESIGN LTD
 181, 182, 183, 184, 185, 186, 187, 188, 189, 190, 191, 192, 193, 194, 195, 196, 197, 198, 199, 200, 201, 202, 203, 204, 205, 206, 207, 208, 209, 210, 211, 212, 213, 214, 215, 216, 217, 218, 219, 220, 221, 222, 223, 224, 225, 226, 227, 228, 229, 230, 231, 232, 233, 234, 235, 236, 237, 238, 239, 240, 241, 242, 243, 244, 245, 246, 247, 248, 249, 250, 251, 252, 253, 254, 255, 256, 257, 258, 259, 260, 261, 262, 263, 264, 265, 266, 267, 268, 269, 270, 271, 272, 273, 274, 275, 276, 277, 278, 279, 280, 281, 282, 283, 284, 285, 286, 287, 288, 289, 290, 291, 292, 293, 294, 295, 296, 297, 298, 299, 300, 301, 302, 303, 304, 305, 306, 307, 308, 309, 310, 311, 312, 313, 314, 315, 316, 317, 318, 319, 320, 321, 322, 323, 324, 325, 326, 327, 328, 329, 330, 331, 332, 333, 334, 335, 336, 337, 338, 339, 340, 341, 342, 343, 344, 345, 346, 347, 348, 349, 350, 351, 352, 353, 354, 355, 356, 357, 358, 359, 360, 361, 362, 363, 364, 365, 366, 367, 368, 369, 370, 371, 372, 373, 374, 375, 376, 377, 378, 379, 380, 381, 382, 383, 384, 385, 386, 387, 388, 389, 390, 391, 392, 393, 394, 395, 396, 397, 398, 399, 400, 401, 402, 403, 404, 405, 406, 407, 408, 409, 410, 411, 412, 413, 414, 415, 416, 417, 418, 419, 420, 421, 422, 423, 424, 425, 426, 427, 428, 429, 430, 431, 432, 433, 434, 435, 436, 437, 438, 439, 440, 441, 442, 443, 444, 445, 446, 447, 448, 449, 450, 451, 452, 453, 454, 455, 456, 457, 458, 459, 460, 461, 462, 463, 464, 465, 466, 467, 468, 469, 470, 471, 472, 473, 474, 475, 476, 477, 478, 479, 480, 481, 482, 483, 484, 485, 486, 487, 488, 489, 490, 491, 492, 493, 494, 495, 496, 497, 498, 499, 500, 501, 502, 503, 504, 505, 506, 507, 508, 509, 510, 511, 512, 513, 514, 515, 516, 517, 518, 519, 520, 521, 522, 523, 524, 525, 526, 527, 528, 529, 530, 531, 532, 533, 534, 535, 536, 537, 538, 539, 540, 541, 542, 543, 544, 545, 546, 547, 548, 549, 550, 551, 552, 553, 554, 555, 556, 557, 558, 559, 560, 561, 562, 563, 564, 565, 566, 567, 568, 569, 570, 571, 572, 573, 574, 575, 576, 577, 578, 579, 580, 581, 582, 583, 584, 585, 586, 587, 588, 589, 590, 591, 592, 593, 594, 595, 596, 597, 598, 599, 600, 601, 602, 603, 604, 605, 606, 607, 608, 609, 610, 611, 612, 613, 614, 615, 616, 617, 618, 619, 620, 621, 622, 623, 624, 625, 626, 627, 628, 629, 630, 631, 632, 633, 634, 635, 636, 637, 638, 639, 640, 641, 642, 643, 644, 645, 646, 647, 648, 649, 650, 651, 652, 653, 654, 655, 656, 657, 658, 659, 660, 661, 662, 663, 664, 665, 666, 667, 668, 669, 670, 671, 672, 673, 674, 675, 676, 677, 678, 679, 680, 681, 682, 683, 684, 685, 686, 687, 688, 689, 690, 691, 692, 693, 694, 695, 696, 697, 698, 699, 700, 701, 702, 703, 704, 705, 706, 707, 708, 709, 710, 711, 712, 713, 714, 715, 716, 717, 718, 719, 720, 721, 722, 723, 724, 725, 726, 727, 728, 729, 730, 731, 732, 733, 734, 735, 736, 737, 738, 739, 740, 741, 742, 743, 744, 745, 746, 747, 748, 749, 750, 751, 752, 753, 754, 755, 756, 757, 758, 759, 760, 761, 762, 763, 764, 765, 766, 767, 768, 769, 770, 771, 772, 773, 774, 775, 776, 777, 778, 779, 780, 781, 782, 783, 784, 785, 786, 787, 788, 789, 790, 791, 792, 793, 794, 795, 796, 797, 798, 799, 800, 801, 802, 803, 804, 805, 806, 807, 808, 809, 810, 811, 812, 813, 814, 815, 816, 817, 818, 819, 820, 821, 822, 823, 824, 825, 826, 827, 828, 829, 830, 831, 832, 833, 834, 835, 836, 837, 838, 839, 840, 841, 842, 843, 844, 845, 846, 847, 848, 849, 850, 851, 852, 853, 854, 855, 856, 857, 858, 859, 860, 861, 862, 863, 864, 865, 866, 867, 868, 869, 870, 871, 872, 873, 874, 875, 876, 877, 878, 879, 880, 881, 882, 883, 884, 885, 886, 887, 888, 889, 890, 891, 892, 893, 894, 895, 896, 897, 898, 899, 900, 901, 902, 903, 904, 905, 906, 907, 908, 909, 910, 911, 912, 913, 914, 915, 916, 917, 918, 919, 920, 921, 922, 923, 924, 925, 926, 927, 928, 929, 930, 931, 932, 933, 934, 935, 936, 937, 938, 939, 940, 941, 942, 943, 944, 945, 946, 947, 948, 949, 950, 951, 952, 953, 954, 955, 956, 957, 958, 959, 960, 961, 962, 963, 964, 965, 966, 967, 968, 969, 970, 971, 972, 973, 974, 975, 976, 977, 978, 979, 980, 981, 982, 983, 984, 985, 986, 987, 988, 989, 990, 991, 992, 993, 994, 995, 996, 997, 998, 999, 1000

MAIN CONTRACTOR :
Gammon

STRUCTURAL ENGINEER :
ARUP

FAÇADE CONSULTANT:
MEINHARDT

NOTE :
 1. ALL DIMENSIONS ARE IN mm.
 2. ALL ELEVATIONS ARE VIEWED FROM OUTSIDE.
 3. ALL DIMENSIONS TO BE VERIFIED ON SITE BEFORE FABRICATION.

LEGEND :
 (X1) — DETAIL MARK NO.
 (X001) — REFER SHEET NO.
 1. F.F.L. — FINISHED FLOOR LEVEL
 2. S.F.L. — STRUCTURAL FLOOR LEVEL
 3. (R) — REVERSED DETAIL

NO.	DATE	REVISION	BY
A	07/11/2020	REVISION SUBJECT TO ARCH.COMMENT	lvart

JOB NO. : J-852
 PROJECT : PROPOSED RESIDENTIAL DEVELOPMENT AT 139 - 147 ARGYLE STREET, NKIL 6005, 6035 R.P., 6036 R.P., 6037 R.P. & 6038 R.P.

TITLE : PART PLAN OF TOWER 1 (22/F)

DATE : 12-Dec-2019 SCALE : 1:150

DRAWN BY : MN CHECKED BY : DW

美特鋁質有限公司
MIDI ALUMINIUM FABRICATOR LTD.
 Units 6-8, Sunray Industrial Centre, 1/F
 610 Cha Kwo Ling Road, Kowloon
 Tel: 23489211-4 Fax: (852)27727666

DWG NO. : J852-SD-PB-3003 REV. : A

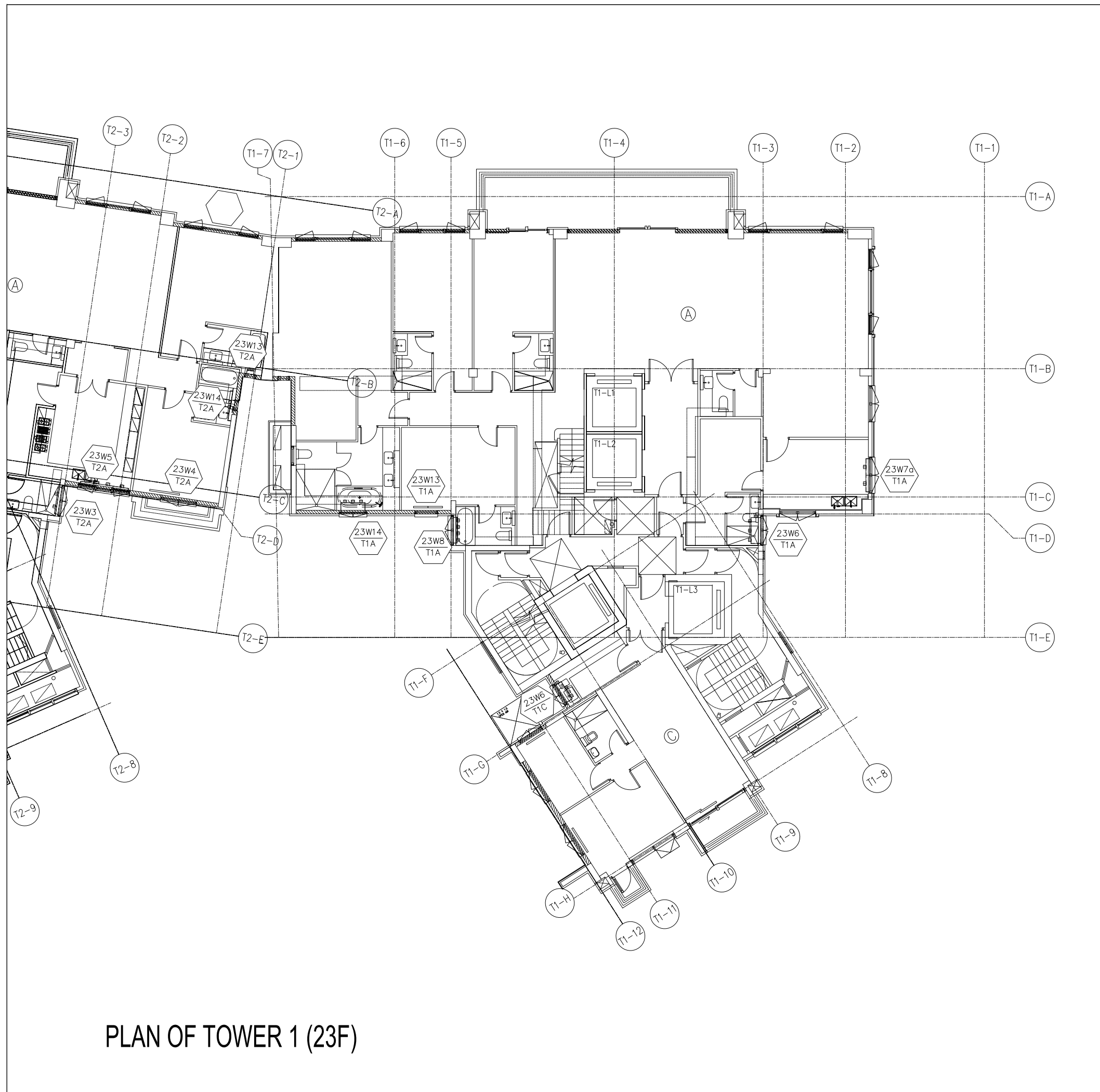

PLAN OF TOWER 1 (23F)

B.D. REF :
 CLIENT :
 ARCHITECT :
AGC DESIGN LTD
 181, 182, 183, 184, 185, 186, 187, 188, 189, 190, 191, 192, 193, 194, 195, 196, 197, 198, 199, 200, 201, 202, 203, 204, 205, 206, 207, 208, 209, 210, 211, 212, 213, 214, 215, 216, 217, 218, 219, 220, 221, 222, 223, 224, 225, 226, 227, 228, 229, 230, 231, 232, 233, 234, 235, 236, 237, 238, 239, 240, 241, 242, 243, 244, 245, 246, 247, 248, 249, 250, 251, 252, 253, 254, 255, 256, 257, 258, 259, 260, 261, 262, 263, 264, 265, 266, 267, 268, 269, 270, 271, 272, 273, 274, 275, 276, 277, 278, 279, 280, 281, 282, 283, 284, 285, 286, 287, 288, 289, 290, 291, 292, 293, 294, 295, 296, 297, 298, 299, 300, 301, 302, 303, 304, 305, 306, 307, 308, 309, 310, 311, 312, 313, 314, 315, 316, 317, 318, 319, 320, 321, 322, 323, 324, 325, 326, 327, 328, 329, 330, 331, 332, 333, 334, 335, 336, 337, 338, 339, 340, 341, 342, 343, 344, 345, 346, 347, 348, 349, 350, 351, 352, 353, 354, 355, 356, 357, 358, 359, 360, 361, 362, 363, 364, 365, 366, 367, 368, 369, 370, 371, 372, 373, 374, 375, 376, 377, 378, 379, 380, 381, 382, 383, 384, 385, 386, 387, 388, 389, 390, 391, 392, 393, 394, 395, 396, 397, 398, 399, 400, 401, 402, 403, 404, 405, 406, 407, 408, 409, 410, 411, 412, 413, 414, 415, 416, 417, 418, 419, 420, 421, 422, 423, 424, 425, 426, 427, 428, 429, 430, 431, 432, 433, 434, 435, 436, 437, 438, 439, 440, 441, 442, 443, 444, 445, 446, 447, 448, 449, 450, 451, 452, 453, 454, 455, 456, 457, 458, 459, 460, 461, 462, 463, 464, 465, 466, 467, 468, 469, 470, 471, 472, 473, 474, 475, 476, 477, 478, 479, 480, 481, 482, 483, 484, 485, 486, 487, 488, 489, 490, 491, 492, 493, 494, 495, 496, 497, 498, 499, 500, 501, 502, 503, 504, 505, 506, 507, 508, 509, 510, 511, 512, 513, 514, 515, 516, 517, 518, 519, 520, 521, 522, 523, 524, 525, 526, 527, 528, 529, 530, 531, 532, 533, 534, 535, 536, 537, 538, 539, 540, 541, 542, 543, 544, 545, 546, 547, 548, 549, 550, 551, 552, 553, 554, 555, 556, 557, 558, 559, 560, 561, 562, 563, 564, 565, 566, 567, 568, 569, 570, 571, 572, 573, 574, 575, 576, 577, 578, 579, 580, 581, 582, 583, 584, 585, 586, 587, 588, 589, 590, 591, 592, 593, 594, 595, 596, 597, 598, 599, 600, 601, 602, 603, 604, 605, 606, 607, 608, 609, 610, 611, 612, 613, 614, 615, 616, 617, 618, 619, 620, 621, 622, 623, 624, 625, 626, 627, 628, 629, 630, 631, 632, 633, 634, 635, 636, 637, 638, 639, 640, 641, 642, 643, 644, 645, 646, 647, 648, 649, 650, 651, 652, 653, 654, 655, 656, 657, 658, 659, 660, 661, 662, 663, 664, 665, 666, 667, 668, 669, 670, 671, 672, 673, 674, 675, 676, 677, 678, 679, 680, 681, 682, 683, 684, 685, 686, 687, 688, 689, 690, 691, 692, 693, 694, 695, 696, 697, 698, 699, 700, 701, 702, 703, 704, 705, 706, 707, 708, 709, 710, 711, 712, 713, 714, 715, 716, 717, 718, 719, 720, 721, 722, 723, 724, 725, 726, 727, 728, 729, 730, 731, 732, 733, 734, 735, 736, 737, 738, 739, 740, 741, 742, 743, 744, 745, 746, 747, 748, 749, 750, 751, 752, 753, 754, 755, 756, 757, 758, 759, 760, 761, 762, 763, 764, 765, 766, 767, 768, 769, 770, 771, 772, 773, 774, 775, 776, 777, 778, 779, 780, 781, 782, 783, 784, 785, 786, 787, 788, 789, 790, 791, 792, 793, 794, 795, 796, 797, 798, 799, 800, 801, 802, 803, 804, 805, 806, 807, 808, 809, 810, 811, 812, 813, 814, 815, 816, 817, 818, 819, 820, 821, 822, 823, 824, 825, 826, 827, 828, 829, 830, 831, 832, 833, 834, 835, 836, 837, 838, 839, 840, 841, 842, 843, 844, 845, 846, 847, 848, 849, 850, 851, 852, 853, 854, 855, 856, 857, 858, 859, 860, 861, 862, 863, 864, 865, 866, 867, 868, 869, 870, 871, 872, 873, 874, 875, 876, 877, 878, 879, 880, 881, 882, 883, 884, 885, 886, 887, 888, 889, 890, 891, 892, 893, 894, 895, 896, 897, 898, 899, 900, 901, 902, 903, 904, 905, 906, 907, 908, 909, 910, 911, 912, 913, 914, 915, 916, 917, 918, 919, 920, 921, 922, 923, 924, 925, 926, 927, 928, 929, 930, 931, 932, 933, 934, 935, 936, 937, 938, 939, 940, 941, 942, 943, 944, 945, 946, 947, 948, 949, 950, 951, 952, 953, 954, 955, 956, 957, 958, 959, 960, 961, 962, 963, 964, 965, 966, 967, 968, 969, 970, 971, 972, 973, 974, 975, 976, 977, 978, 979, 980, 981, 982, 983, 984, 985, 986, 987, 988, 989, 990, 991, 992, 993, 994, 995, 996, 997, 998, 999, 1000

NOTE :
 1. ALL DIMENSIONS ARE IN mm.
 2. ALL ELEVATIONS ARE VIEWED FROM OUTSIDE.
 3. ALL DIMENSIONS TO BE VERIFIED ON SITE BEFORE FABRICATION.

LEGEND :
 x1 — DETAIL MARK NO.
 x001 — REFER SHEET NO.

1. F.F.L. -- FINISHED FLOOR LEVEL
 2. S.F.L. -- STRUCTURAL FLOOR LEVEL
 3. (R) -- REVERSED DETAIL

NO.	DATE	REVISED	BY
JOB NO. : J-852			
PROJECT : PROPOSED RESIDENTIAL DEVELOPMENT AT 139 - 147 ARGYLE STREET, NKIL 6005, 6035 R.P., 6036 R.P., 6037 R.P. & 6038 R.P.			
TITLE : PART PLAN OF TOWER 1 (23/F)			
DATE : 12-Dec-2019		SCALE : 1:150	
DRAWN BY : MN		CHECKED BY : DW	
美特鋁質有限公司 MIDI ALUMINIUM FABRICATOR LTD. Units 6-8, Sunray Industrial Centre, 1/F 610 Cha Kwo Ling Road, Kowloon Tel: 23489211-4 Fax: (852)27727666			
DWG NO. : J852-SD-PB-3004			REV. : -

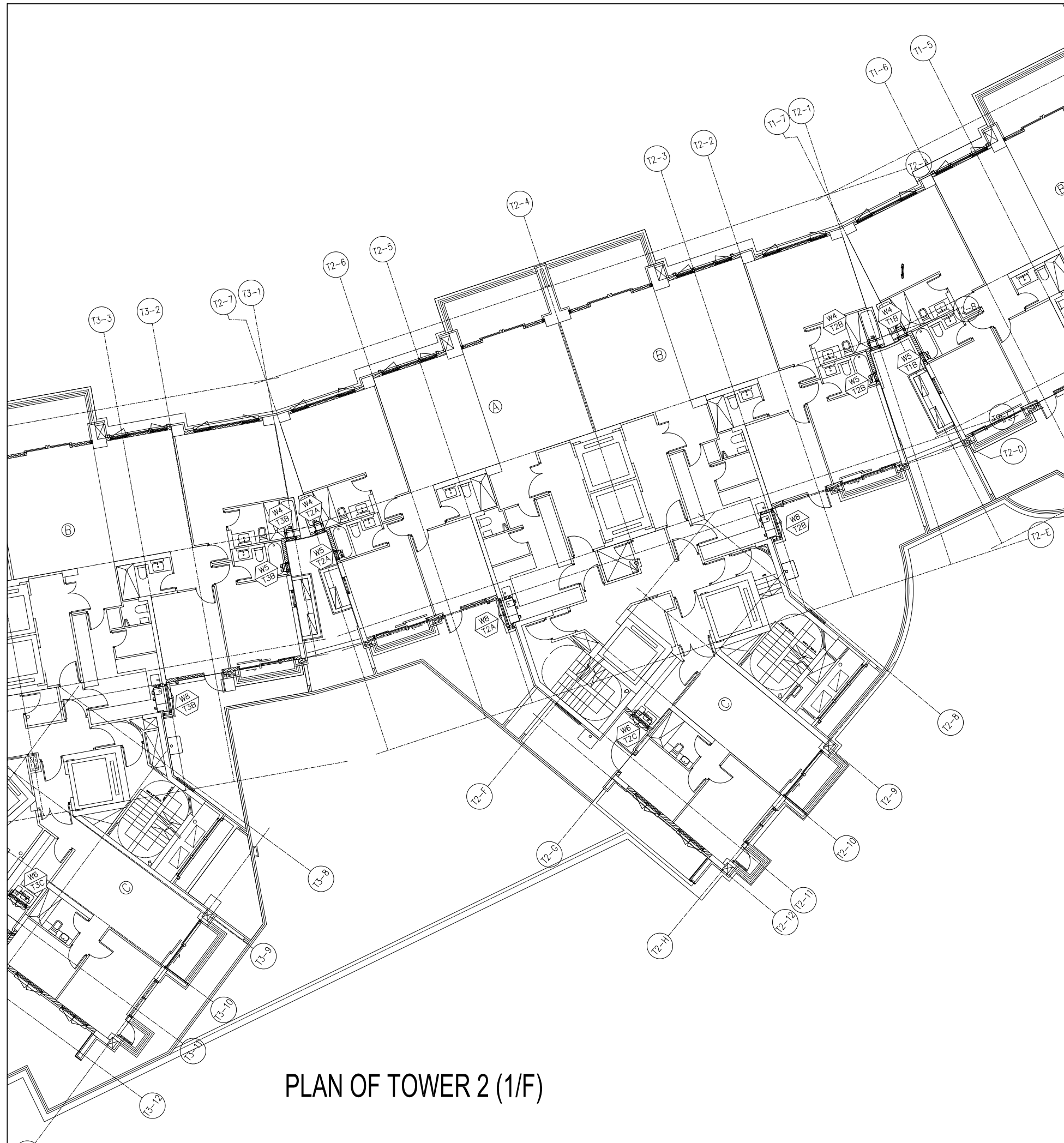

PLAN OF TOWER 2 (1/F)

B.D. REF :

CLIENT :

ARCHITECT :
AGC DESIGN LTD
 101, 102, 103, 104, 105, 106, 107, 108, 109, 110, 111, 112, 113, 114, 115, 116, 117, 118, 119, 120, 121, 122, 123, 124, 125, 126, 127, 128, 129, 130, 131, 132, 133, 134, 135, 136, 137, 138, 139, 140, 141, 142, 143, 144, 145, 146, 147, 148, 149, 150, 151, 152, 153, 154, 155, 156, 157, 158, 159, 160, 161, 162, 163, 164, 165, 166, 167, 168, 169, 170, 171, 172, 173, 174, 175, 176, 177, 178, 179, 180, 181, 182, 183, 184, 185, 186, 187, 188, 189, 190, 191, 192, 193, 194, 195, 196, 197, 198, 199, 200, 201, 202, 203, 204, 205, 206, 207, 208, 209, 210, 211, 212, 213, 214, 215, 216, 217, 218, 219, 220, 221, 222, 223, 224, 225, 226, 227, 228, 229, 230, 231, 232, 233, 234, 235, 236, 237, 238, 239, 240, 241, 242, 243, 244, 245, 246, 247, 248, 249, 250, 251, 252, 253, 254, 255, 256, 257, 258, 259, 260, 261, 262, 263, 264, 265, 266, 267, 268, 269, 270, 271, 272, 273, 274, 275, 276, 277, 278, 279, 280, 281, 282, 283, 284, 285, 286, 287, 288, 289, 290, 291, 292, 293, 294, 295, 296, 297, 298, 299, 300, 301, 302, 303, 304, 305, 306, 307, 308, 309, 310, 311, 312, 313, 314, 315, 316, 317, 318, 319, 320, 321, 322, 323, 324, 325, 326, 327, 328, 329, 330, 331, 332, 333, 334, 335, 336, 337, 338, 339, 340, 341, 342, 343, 344, 345, 346, 347, 348, 349, 350, 351, 352, 353, 354, 355, 356, 357, 358, 359, 360, 361, 362, 363, 364, 365, 366, 367, 368, 369, 370, 371, 372, 373, 374, 375, 376, 377, 378, 379, 380, 381, 382, 383, 384, 385, 386, 387, 388, 389, 390, 391, 392, 393, 394, 395, 396, 397, 398, 399, 400, 401, 402, 403, 404, 405, 406, 407, 408, 409, 410, 411, 412, 413, 414, 415, 416, 417, 418, 419, 420, 421, 422, 423, 424, 425, 426, 427, 428, 429, 430, 431, 432, 433, 434, 435, 436, 437, 438, 439, 440, 441, 442, 443, 444, 445, 446, 447, 448, 449, 450, 451, 452, 453, 454, 455, 456, 457, 458, 459, 460, 461, 462, 463, 464, 465, 466, 467, 468, 469, 470, 471, 472, 473, 474, 475, 476, 477, 478, 479, 480, 481, 482, 483, 484, 485, 486, 487, 488, 489, 490, 491, 492, 493, 494, 495, 496, 497, 498, 499, 500, 501, 502, 503, 504, 505, 506, 507, 508, 509, 510, 511, 512, 513, 514, 515, 516, 517, 518, 519, 520, 521, 522, 523, 524, 525, 526, 527, 528, 529, 530, 531, 532, 533, 534, 535, 536, 537, 538, 539, 540, 541, 542, 543, 544, 545, 546, 547, 548, 549, 550, 551, 552, 553, 554, 555, 556, 557, 558, 559, 560, 561, 562, 563, 564, 565, 566, 567, 568, 569, 570, 571, 572, 573, 574, 575, 576, 577, 578, 579, 580, 581, 582, 583, 584, 585, 586, 587, 588, 589, 590, 591, 592, 593, 594, 595, 596, 597, 598, 599, 600, 601, 602, 603, 604, 605, 606, 607, 608, 609, 610, 611, 612, 613, 614, 615, 616, 617, 618, 619, 620, 621, 622, 623, 624, 625, 626, 627, 628, 629, 630, 631, 632, 633, 634, 635, 636, 637, 638, 639, 640, 641, 642, 643, 644, 645, 646, 647, 648, 649, 650, 651, 652, 653, 654, 655, 656, 657, 658, 659, 660, 661, 662, 663, 664, 665, 666, 667, 668, 669, 670, 671, 672, 673, 674, 675, 676, 677, 678, 679, 680, 681, 682, 683, 684, 685, 686, 687, 688, 689, 690, 691, 692, 693, 694, 695, 696, 697, 698, 699, 700, 701, 702, 703, 704, 705, 706, 707, 708, 709, 710, 711, 712, 713, 714, 715, 716, 717, 718, 719, 720, 721, 722, 723, 724, 725, 726, 727, 728, 729, 730, 731, 732, 733, 734, 735, 736, 737, 738, 739, 740, 741, 742, 743, 744, 745, 746, 747, 748, 749, 750, 751, 752, 753, 754, 755, 756, 757, 758, 759, 760, 761, 762, 763, 764, 765, 766, 767, 768, 769, 770, 771, 772, 773, 774, 775, 776, 777, 778, 779, 780, 781, 782, 783, 784, 785, 786, 787, 788, 789, 790, 791, 792, 793, 794, 795, 796, 797, 798, 799, 800, 801, 802, 803, 804, 805, 806, 807, 808, 809, 810, 811, 812, 813, 814, 815, 816, 817, 818, 819, 820, 821, 822, 823, 824, 825, 826, 827, 828, 829, 830, 831, 832, 833, 834, 835, 836, 837, 838, 839, 840, 841, 842, 843, 844, 845, 846, 847, 848, 849, 850, 851, 852, 853, 854, 855, 856, 857, 858, 859, 860, 861, 862, 863, 864, 865, 866, 867, 868, 869, 870, 871, 872, 873, 874, 875, 876, 877, 878, 879, 880, 881, 882, 883, 884, 885, 886, 887, 888, 889, 890, 891, 892, 893, 894, 895, 896, 897, 898, 899, 900, 901, 902, 903, 904, 905, 906, 907, 908, 909, 910, 911, 912, 913, 914, 915, 916, 917, 918, 919, 920, 921, 922, 923, 924, 925, 926, 927, 928, 929, 930, 931, 932, 933, 934, 935, 936, 937, 938, 939, 940, 941, 942, 943, 944, 945, 946, 947, 948, 949, 950, 951, 952, 953, 954, 955, 956, 957, 958, 959, 960, 961, 962, 963, 964, 965, 966, 967, 968, 969, 970, 971, 972, 973, 974, 975, 976, 977, 978, 979, 980, 981, 982, 983, 984, 985, 986, 987, 988, 989, 990, 991, 992, 993, 994, 995, 996, 997, 998, 999, 1000

MAIN CONTRACTOR :
Gammon

STRUCTURAL ENGINEER :
ARUP

FACADE CONSULTANT:
MEINHARDT

NOTE :
 1. ALL DIMENSIONS ARE IN mm.
 2. ALL ELEVATIONS ARE VIEWED FROM OUTSIDE.
 3. ALL DIMENSIONS TO BE VERIFIED ON SITE BEFORE FABRICATION.

LEGEND :
 (X1) --- DETAIL MARK NO.
 (X001) --- REFER SHEET NO.
 1. F.F.L. --- FINISHED FLOOR LEVEL
 2. S.F.L. --- STRUCTURAL FLOOR LEVEL
 3. (R) --- REVERSED DETAIL

NO.	DATE	REVISED	BY
-----	------	---------	----

JOB NO. : J-852
 PROJECT : PROPOSED RESIDENTIAL DEVELOPMENT AT 139 - 147 ARGYLE STREET, NKIL 6005, 6035 R.P., 6036 R.P., 6037 R.P. & 6038 R.P.

TITLE : PART PLAN OF TOWER 2(1/F)

DATE : 12-Dec-2019 SCALE : 1:150

DRAWN BY : MN CHECKED BY : DW

美特鋁質有限公司
MIDI ALUMINIUM FABRICATOR LTD.
 Units 6-8, Sunray Industrial Centre, 1/F
 610 Cha Kwo Ling Road, Kowloon
 Tel: 23489211-4 Fax: (852)2727666

DWG NO. : J852-SD-PB-3005 REV. : -



PLAN OF TOWER 2 (2/F~21F)

B.D. REF : _____

CLIENT : _____

ARCHITECT : **AGC DESIGN LTD**
AGC DESIGN LTD
 10/F, 107, Queen's Road, 222, York Road, North Point, Hong Kong
 Tel: (852)27717100 Fax: (852)27717111 Email: agc@agc.com.hk

MAIN CONTRACTOR : **Gammon**

STRUCTURAL ENGINEER : **ARUP**

FACADE CONSULTANT: **MEINHARDT**

NOTE :
 1. ALL DIMENSIONS ARE IN mm.
 2. ALL ELEVATIONS ARE VIEWED FROM OUTSIDE.
 3. ALL DIMENSIONS TO BE VERIFIED ON SITE BEFORE FABRICATION.

LEGEND :
 X1 ———— DETAIL MARK NO.
 X001 ———— REFER SHEET NO.

1. F.F.L. --- FINISHED FLOOR LEVEL
 2. S.F.L. --- STRUCTURAL FLOOR LEVEL
 3. /R --- REVERSED DETAIL

NO.	DATE	REVISED	BY

JOB NO. : J-852

PROJECT : PROPOSED RESIDENTIAL DEVELOPMENT
 AT 139 - 147 ARGYLE STREET,
 NKIL 6005, 6035 R.P., 6036 R.P.,
 6037 R.P. & 6038 R.P.

TITLE : PART PLAN OF
 TOWER 2 (2-21/F)

DATE : 12-Dec-2019 SCALE : 1:150

DRAWN BY : MN CHECKED BY : DW

美特鋁質有限公司
MIDI ALUMINIUM FABRICATOR LTD.
 Units 6-8, Sunray Industrial Centre, 1/F
 610 Cha Kwo Ling Road, Kowloon
 Tel: 23489211-4 Fax: (852)27727666

DWG NO. : J852-SD-PW-3006 REV. : -



PLAN OF TOWER 2 (22F)

B.D. REF :

CLIENT :

ARCHITECT :
AGC DESIGN LTD
 101, 102, 103, 104, 105, 106, 107, 108, 109, 110, 111, 112, 113, 114, 115, 116, 117, 118, 119, 120, 121, 122, 123, 124, 125, 126, 127, 128, 129, 130, 131, 132, 133, 134, 135, 136, 137, 138, 139, 140, 141, 142, 143, 144, 145, 146, 147, 148, 149, 150, 151, 152, 153, 154, 155, 156, 157, 158, 159, 160, 161, 162, 163, 164, 165, 166, 167, 168, 169, 170, 171, 172, 173, 174, 175, 176, 177, 178, 179, 180, 181, 182, 183, 184, 185, 186, 187, 188, 189, 190, 191, 192, 193, 194, 195, 196, 197, 198, 199, 200, 201, 202, 203, 204, 205, 206, 207, 208, 209, 210, 211, 212, 213, 214, 215, 216, 217, 218, 219, 220, 221, 222, 223, 224, 225, 226, 227, 228, 229, 230, 231, 232, 233, 234, 235, 236, 237, 238, 239, 240, 241, 242, 243, 244, 245, 246, 247, 248, 249, 250, 251, 252, 253, 254, 255, 256, 257, 258, 259, 260, 261, 262, 263, 264, 265, 266, 267, 268, 269, 270, 271, 272, 273, 274, 275, 276, 277, 278, 279, 280, 281, 282, 283, 284, 285, 286, 287, 288, 289, 290, 291, 292, 293, 294, 295, 296, 297, 298, 299, 300, 301, 302, 303, 304, 305, 306, 307, 308, 309, 310, 311, 312, 313, 314, 315, 316, 317, 318, 319, 320, 321, 322, 323, 324, 325, 326, 327, 328, 329, 330, 331, 332, 333, 334, 335, 336, 337, 338, 339, 340, 341, 342, 343, 344, 345, 346, 347, 348, 349, 350, 351, 352, 353, 354, 355, 356, 357, 358, 359, 360, 361, 362, 363, 364, 365, 366, 367, 368, 369, 370, 371, 372, 373, 374, 375, 376, 377, 378, 379, 380, 381, 382, 383, 384, 385, 386, 387, 388, 389, 390, 391, 392, 393, 394, 395, 396, 397, 398, 399, 400, 401, 402, 403, 404, 405, 406, 407, 408, 409, 410, 411, 412, 413, 414, 415, 416, 417, 418, 419, 420, 421, 422, 423, 424, 425, 426, 427, 428, 429, 430, 431, 432, 433, 434, 435, 436, 437, 438, 439, 440, 441, 442, 443, 444, 445, 446, 447, 448, 449, 450, 451, 452, 453, 454, 455, 456, 457, 458, 459, 460, 461, 462, 463, 464, 465, 466, 467, 468, 469, 470, 471, 472, 473, 474, 475, 476, 477, 478, 479, 480, 481, 482, 483, 484, 485, 486, 487, 488, 489, 490, 491, 492, 493, 494, 495, 496, 497, 498, 499, 500, 501, 502, 503, 504, 505, 506, 507, 508, 509, 510, 511, 512, 513, 514, 515, 516, 517, 518, 519, 520, 521, 522, 523, 524, 525, 526, 527, 528, 529, 530, 531, 532, 533, 534, 535, 536, 537, 538, 539, 540, 541, 542, 543, 544, 545, 546, 547, 548, 549, 550, 551, 552, 553, 554, 555, 556, 557, 558, 559, 560, 561, 562, 563, 564, 565, 566, 567, 568, 569, 570, 571, 572, 573, 574, 575, 576, 577, 578, 579, 580, 581, 582, 583, 584, 585, 586, 587, 588, 589, 590, 591, 592, 593, 594, 595, 596, 597, 598, 599, 600, 601, 602, 603, 604, 605, 606, 607, 608, 609, 610, 611, 612, 613, 614, 615, 616, 617, 618, 619, 620, 621, 622, 623, 624, 625, 626, 627, 628, 629, 630, 631, 632, 633, 634, 635, 636, 637, 638, 639, 640, 641, 642, 643, 644, 645, 646, 647, 648, 649, 650, 651, 652, 653, 654, 655, 656, 657, 658, 659, 660, 661, 662, 663, 664, 665, 666, 667, 668, 669, 670, 671, 672, 673, 674, 675, 676, 677, 678, 679, 680, 681, 682, 683, 684, 685, 686, 687, 688, 689, 690, 691, 692, 693, 694, 695, 696, 697, 698, 699, 700, 701, 702, 703, 704, 705, 706, 707, 708, 709, 710, 711, 712, 713, 714, 715, 716, 717, 718, 719, 720, 721, 722, 723, 724, 725, 726, 727, 728, 729, 730, 731, 732, 733, 734, 735, 736, 737, 738, 739, 740, 741, 742, 743, 744, 745, 746, 747, 748, 749, 750, 751, 752, 753, 754, 755, 756, 757, 758, 759, 760, 761, 762, 763, 764, 765, 766, 767, 768, 769, 770, 771, 772, 773, 774, 775, 776, 777, 778, 779, 780, 781, 782, 783, 784, 785, 786, 787, 788, 789, 790, 791, 792, 793, 794, 795, 796, 797, 798, 799, 800, 801, 802, 803, 804, 805, 806, 807, 808, 809, 810, 811, 812, 813, 814, 815, 816, 817, 818, 819, 820, 821, 822, 823, 824, 825, 826, 827, 828, 829, 830, 831, 832, 833, 834, 835, 836, 837, 838, 839, 840, 841, 842, 843, 844, 845, 846, 847, 848, 849, 850, 851, 852, 853, 854, 855, 856, 857, 858, 859, 860, 861, 862, 863, 864, 865, 866, 867, 868, 869, 870, 871, 872, 873, 874, 875, 876, 877, 878, 879, 880, 881, 882, 883, 884, 885, 886, 887, 888, 889, 890, 891, 892, 893, 894, 895, 896, 897, 898, 899, 900, 901, 902, 903, 904, 905, 906, 907, 908, 909, 910, 911, 912, 913, 914, 915, 916, 917, 918, 919, 920, 921, 922, 923, 924, 925, 926, 927, 928, 929, 930, 931, 932, 933, 934, 935, 936, 937, 938, 939, 940, 941, 942, 943, 944, 945, 946, 947, 948, 949, 950, 951, 952, 953, 954, 955, 956, 957, 958, 959, 960, 961, 962, 963, 964, 965, 966, 967, 968, 969, 970, 971, 972, 973, 974, 975, 976, 977, 978, 979, 980, 981, 982, 983, 984, 985, 986, 987, 988, 989, 990, 991, 992, 993, 994, 995, 996, 997, 998, 999, 1000

MAIN CONTRACTOR :
Gammon

STRUCTURAL ENGINEER :
ARUP

FACADE CONSULTANT:
MEINHARDT

NOTE :
 1. ALL DIMENSIONS ARE IN mm.
 2. ALL ELEVATIONS ARE VIEWED FROM OUTSIDE.
 3. ALL DIMENSIONS TO BE VERIFIED ON SITE BEFORE FABRICATION.

LEGEND :
 x1 --- DETAIL MARK NO.
 x001 --- REFER SHEET NO.
 1. F.F.L. --- FINISHED FLOOR LEVEL
 2. S.F.L. --- STRUCTURAL FLOOR LEVEL
 3. (R) --- REVERSED DETAIL

NO.	DATE	REVISED	BY
-----	------	---------	----

JOB NO. : J-852
 PROJECT : PROPOSED RESIDENTIAL DEVELOPMENT AT 139 - 147 ARGYLE STREET, NKIL 6005, 6035 R.P., 6036 R.P., 6037 R.P. & 6038 R.P.

TITLE : PART PLAN OF TOWER 2 (22/F)

DATE : 12-Dec-2019 SCALE : 1:150

DRAWN BY : MN CHECKED BY : DW

美特鋁質有限公司
MIDI ALUMINIUM FABRICATOR LTD.
 Units 6-8, Sunray Industrial Centre, 1/F
 610 Cha Kwo Ling Road, Kowloon
 Tel: 23489211-4 Fax: (852)27727666
 DWG NO. : J852-SD-PB-3007 REV. : A

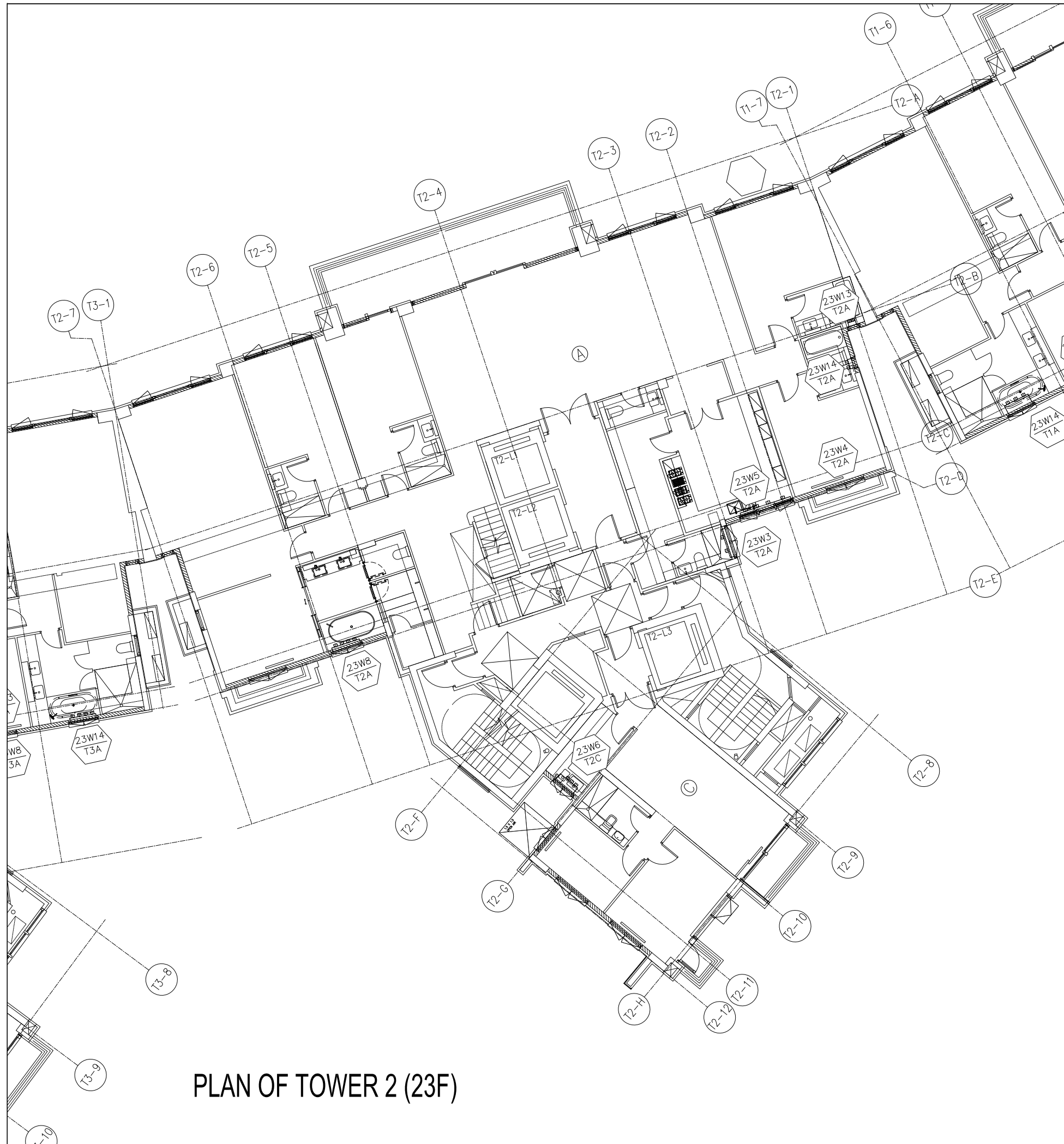

PLAN OF TOWER 2 (23F)

B.D. REF :

CLIENT :

ARCHITECT :
AGC DESIGN LTD
 101, 102, 103, 104, 105, 106, 107, 108, 109, 110, 111, 112, 113, 114, 115, 116, 117, 118, 119, 120, 121, 122, 123, 124, 125, 126, 127, 128, 129, 130, 131, 132, 133, 134, 135, 136, 137, 138, 139, 140, 141, 142, 143, 144, 145, 146, 147, 148, 149, 150, 151, 152, 153, 154, 155, 156, 157, 158, 159, 160, 161, 162, 163, 164, 165, 166, 167, 168, 169, 170, 171, 172, 173, 174, 175, 176, 177, 178, 179, 180, 181, 182, 183, 184, 185, 186, 187, 188, 189, 190, 191, 192, 193, 194, 195, 196, 197, 198, 199, 200, 201, 202, 203, 204, 205, 206, 207, 208, 209, 210, 211, 212, 213, 214, 215, 216, 217, 218, 219, 220, 221, 222, 223, 224, 225, 226, 227, 228, 229, 230, 231, 232, 233, 234, 235, 236, 237, 238, 239, 240, 241, 242, 243, 244, 245, 246, 247, 248, 249, 250, 251, 252, 253, 254, 255, 256, 257, 258, 259, 260, 261, 262, 263, 264, 265, 266, 267, 268, 269, 270, 271, 272, 273, 274, 275, 276, 277, 278, 279, 280, 281, 282, 283, 284, 285, 286, 287, 288, 289, 290, 291, 292, 293, 294, 295, 296, 297, 298, 299, 300, 301, 302, 303, 304, 305, 306, 307, 308, 309, 310, 311, 312, 313, 314, 315, 316, 317, 318, 319, 320, 321, 322, 323, 324, 325, 326, 327, 328, 329, 330, 331, 332, 333, 334, 335, 336, 337, 338, 339, 340, 341, 342, 343, 344, 345, 346, 347, 348, 349, 350, 351, 352, 353, 354, 355, 356, 357, 358, 359, 360, 361, 362, 363, 364, 365, 366, 367, 368, 369, 370, 371, 372, 373, 374, 375, 376, 377, 378, 379, 380, 381, 382, 383, 384, 385, 386, 387, 388, 389, 390, 391, 392, 393, 394, 395, 396, 397, 398, 399, 400, 401, 402, 403, 404, 405, 406, 407, 408, 409, 410, 411, 412, 413, 414, 415, 416, 417, 418, 419, 420, 421, 422, 423, 424, 425, 426, 427, 428, 429, 430, 431, 432, 433, 434, 435, 436, 437, 438, 439, 440, 441, 442, 443, 444, 445, 446, 447, 448, 449, 450, 451, 452, 453, 454, 455, 456, 457, 458, 459, 460, 461, 462, 463, 464, 465, 466, 467, 468, 469, 470, 471, 472, 473, 474, 475, 476, 477, 478, 479, 480, 481, 482, 483, 484, 485, 486, 487, 488, 489, 490, 491, 492, 493, 494, 495, 496, 497, 498, 499, 500, 501, 502, 503, 504, 505, 506, 507, 508, 509, 510, 511, 512, 513, 514, 515, 516, 517, 518, 519, 520, 521, 522, 523, 524, 525, 526, 527, 528, 529, 530, 531, 532, 533, 534, 535, 536, 537, 538, 539, 540, 541, 542, 543, 544, 545, 546, 547, 548, 549, 550, 551, 552, 553, 554, 555, 556, 557, 558, 559, 560, 561, 562, 563, 564, 565, 566, 567, 568, 569, 570, 571, 572, 573, 574, 575, 576, 577, 578, 579, 580, 581, 582, 583, 584, 585, 586, 587, 588, 589, 590, 591, 592, 593, 594, 595, 596, 597, 598, 599, 600, 601, 602, 603, 604, 605, 606, 607, 608, 609, 610, 611, 612, 613, 614, 615, 616, 617, 618, 619, 620, 621, 622, 623, 624, 625, 626, 627, 628, 629, 630, 631, 632, 633, 634, 635, 636, 637, 638, 639, 640, 641, 642, 643, 644, 645, 646, 647, 648, 649, 650, 651, 652, 653, 654, 655, 656, 657, 658, 659, 660, 661, 662, 663, 664, 665, 666, 667, 668, 669, 670, 671, 672, 673, 674, 675, 676, 677, 678, 679, 680, 681, 682, 683, 684, 685, 686, 687, 688, 689, 690, 691, 692, 693, 694, 695, 696, 697, 698, 699, 700, 701, 702, 703, 704, 705, 706, 707, 708, 709, 710, 711, 712, 713, 714, 715, 716, 717, 718, 719, 720, 721, 722, 723, 724, 725, 726, 727, 728, 729, 730, 731, 732, 733, 734, 735, 736, 737, 738, 739, 740, 741, 742, 743, 744, 745, 746, 747, 748, 749, 750, 751, 752, 753, 754, 755, 756, 757, 758, 759, 760, 761, 762, 763, 764, 765, 766, 767, 768, 769, 770, 771, 772, 773, 774, 775, 776, 777, 778, 779, 780, 781, 782, 783, 784, 785, 786, 787, 788, 789, 790, 791, 792, 793, 794, 795, 796, 797, 798, 799, 800, 801, 802, 803, 804, 805, 806, 807, 808, 809, 810, 811, 812, 813, 814, 815, 816, 817, 818, 819, 820, 821, 822, 823, 824, 825, 826, 827, 828, 829, 830, 831, 832, 833, 834, 835, 836, 837, 838, 839, 840, 841, 842, 843, 844, 845, 846, 847, 848, 849, 850, 851, 852, 853, 854, 855, 856, 857, 858, 859, 860, 861, 862, 863, 864, 865, 866, 867, 868, 869, 870, 871, 872, 873, 874, 875, 876, 877, 878, 879, 880, 881, 882, 883, 884, 885, 886, 887, 888, 889, 890, 891, 892, 893, 894, 895, 896, 897, 898, 899, 900, 901, 902, 903, 904, 905, 906, 907, 908, 909, 910, 911, 912, 913, 914, 915, 916, 917, 918, 919, 920, 921, 922, 923, 924, 925, 926, 927, 928, 929, 930, 931, 932, 933, 934, 935, 936, 937, 938, 939, 940, 941, 942, 943, 944, 945, 946, 947, 948, 949, 950, 951, 952, 953, 954, 955, 956, 957, 958, 959, 960, 961, 962, 963, 964, 965, 966, 967, 968, 969, 970, 971, 972, 973, 974, 975, 976, 977, 978, 979, 980, 981, 982, 983, 984, 985, 986, 987, 988, 989, 990, 991, 992, 993, 994, 995, 996, 997, 998, 999, 1000

MAIN CONTRACTOR :
Gammon

STRUCTURAL ENGINEER :
ARUP

FACADE CONSULTANT:
MEINHARDT

NOTE :
 1. ALL DIMENSIONS ARE IN mm.
 2. ALL ELEVATIONS ARE VIEWED FROM OUTSIDE.
 3. ALL DIMENSIONS TO BE VERIFIED ON SITE BEFORE FABRICATION.

LEGEND :
 (X1) --- DETAIL MARK NO.
 (X001) --- REFER SHEET NO.
 1. F.F.L. --- FINISHED FLOOR LEVEL
 2. S.F.L. --- STRUCTURAL FLOOR LEVEL
 3. (R) --- REVERSED DETAIL

NO.	DATE	REVISED	BY
-----	------	---------	----

JOB NO. : J-852
 PROJECT : PROPOSED RESIDENTIAL DEVELOPMENT AT 139 - 147 ARGYLE STREET, NKIL 6005, 6035 R.P., 6036 R.P., 6037 R.P. & 6038 R.P.

TITLE : PART PLAN OF TOWER 2 (23/F)

DATE : 12-Dec-2019 SCALE : 1:150

DRAWN BY : MN CHECKED BY : DW

美特鋁質有限公司
MIDI ALUMINIUM FABRICATOR LTD.
 Units 6-8, Sunray Industrial Centre, 1/F
 610 Cha Kwo Ling Road, Kowloon
 Tel: 23489211-4 Fax: (852)2727666

DWG NO. : J852-SD-PB-3008 REV. : -



PLAN OF TOWER 3 (1/F)

B.D. REF :

CLIENT :

ARCHITECT :
AGC DESIGN LTD
 101, 102, 103, 104, 105, 106, 107, 108, 109, 110, 111, 112, 113, 114, 115, 116, 117, 118, 119, 120, 121, 122, 123, 124, 125, 126, 127, 128, 129, 130, 131, 132, 133, 134, 135, 136, 137, 138, 139, 140, 141, 142, 143, 144, 145, 146, 147, 148, 149, 150, 151, 152, 153, 154, 155, 156, 157, 158, 159, 160, 161, 162, 163, 164, 165, 166, 167, 168, 169, 170, 171, 172, 173, 174, 175, 176, 177, 178, 179, 180, 181, 182, 183, 184, 185, 186, 187, 188, 189, 190, 191, 192, 193, 194, 195, 196, 197, 198, 199, 200, 201, 202, 203, 204, 205, 206, 207, 208, 209, 210, 211, 212, 213, 214, 215, 216, 217, 218, 219, 220, 221, 222, 223, 224, 225, 226, 227, 228, 229, 230, 231, 232, 233, 234, 235, 236, 237, 238, 239, 240, 241, 242, 243, 244, 245, 246, 247, 248, 249, 250, 251, 252, 253, 254, 255, 256, 257, 258, 259, 260, 261, 262, 263, 264, 265, 266, 267, 268, 269, 270, 271, 272, 273, 274, 275, 276, 277, 278, 279, 280, 281, 282, 283, 284, 285, 286, 287, 288, 289, 290, 291, 292, 293, 294, 295, 296, 297, 298, 299, 300, 301, 302, 303, 304, 305, 306, 307, 308, 309, 310, 311, 312, 313, 314, 315, 316, 317, 318, 319, 320, 321, 322, 323, 324, 325, 326, 327, 328, 329, 330, 331, 332, 333, 334, 335, 336, 337, 338, 339, 340, 341, 342, 343, 344, 345, 346, 347, 348, 349, 350, 351, 352, 353, 354, 355, 356, 357, 358, 359, 360, 361, 362, 363, 364, 365, 366, 367, 368, 369, 370, 371, 372, 373, 374, 375, 376, 377, 378, 379, 380, 381, 382, 383, 384, 385, 386, 387, 388, 389, 390, 391, 392, 393, 394, 395, 396, 397, 398, 399, 400, 401, 402, 403, 404, 405, 406, 407, 408, 409, 410, 411, 412, 413, 414, 415, 416, 417, 418, 419, 420, 421, 422, 423, 424, 425, 426, 427, 428, 429, 430, 431, 432, 433, 434, 435, 436, 437, 438, 439, 440, 441, 442, 443, 444, 445, 446, 447, 448, 449, 450, 451, 452, 453, 454, 455, 456, 457, 458, 459, 460, 461, 462, 463, 464, 465, 466, 467, 468, 469, 470, 471, 472, 473, 474, 475, 476, 477, 478, 479, 480, 481, 482, 483, 484, 485, 486, 487, 488, 489, 490, 491, 492, 493, 494, 495, 496, 497, 498, 499, 500, 501, 502, 503, 504, 505, 506, 507, 508, 509, 510, 511, 512, 513, 514, 515, 516, 517, 518, 519, 520, 521, 522, 523, 524, 525, 526, 527, 528, 529, 530, 531, 532, 533, 534, 535, 536, 537, 538, 539, 540, 541, 542, 543, 544, 545, 546, 547, 548, 549, 550, 551, 552, 553, 554, 555, 556, 557, 558, 559, 560, 561, 562, 563, 564, 565, 566, 567, 568, 569, 570, 571, 572, 573, 574, 575, 576, 577, 578, 579, 580, 581, 582, 583, 584, 585, 586, 587, 588, 589, 590, 591, 592, 593, 594, 595, 596, 597, 598, 599, 600, 601, 602, 603, 604, 605, 606, 607, 608, 609, 610, 611, 612, 613, 614, 615, 616, 617, 618, 619, 620, 621, 622, 623, 624, 625, 626, 627, 628, 629, 630, 631, 632, 633, 634, 635, 636, 637, 638, 639, 640, 641, 642, 643, 644, 645, 646, 647, 648, 649, 650, 651, 652, 653, 654, 655, 656, 657, 658, 659, 660, 661, 662, 663, 664, 665, 666, 667, 668, 669, 670, 671, 672, 673, 674, 675, 676, 677, 678, 679, 680, 681, 682, 683, 684, 685, 686, 687, 688, 689, 690, 691, 692, 693, 694, 695, 696, 697, 698, 699, 700, 701, 702, 703, 704, 705, 706, 707, 708, 709, 710, 711, 712, 713, 714, 715, 716, 717, 718, 719, 720, 721, 722, 723, 724, 725, 726, 727, 728, 729, 730, 731, 732, 733, 734, 735, 736, 737, 738, 739, 740, 741, 742, 743, 744, 745, 746, 747, 748, 749, 750, 751, 752, 753, 754, 755, 756, 757, 758, 759, 760, 761, 762, 763, 764, 765, 766, 767, 768, 769, 770, 771, 772, 773, 774, 775, 776, 777, 778, 779, 780, 781, 782, 783, 784, 785, 786, 787, 788, 789, 790, 791, 792, 793, 794, 795, 796, 797, 798, 799, 800, 801, 802, 803, 804, 805, 806, 807, 808, 809, 810, 811, 812, 813, 814, 815, 816, 817, 818, 819, 820, 821, 822, 823, 824, 825, 826, 827, 828, 829, 830, 831, 832, 833, 834, 835, 836, 837, 838, 839, 840, 841, 842, 843, 844, 845, 846, 847, 848, 849, 850, 851, 852, 853, 854, 855, 856, 857, 858, 859, 860, 861, 862, 863, 864, 865, 866, 867, 868, 869, 870, 871, 872, 873, 874, 875, 876, 877, 878, 879, 880, 881, 882, 883, 884, 885, 886, 887, 888, 889, 890, 891, 892, 893, 894, 895, 896, 897, 898, 899, 900, 901, 902, 903, 904, 905, 906, 907, 908, 909, 910, 911, 912, 913, 914, 915, 916, 917, 918, 919, 920, 921, 922, 923, 924, 925, 926, 927, 928, 929, 930, 931, 932, 933, 934, 935, 936, 937, 938, 939, 940, 941, 942, 943, 944, 945, 946, 947, 948, 949, 950, 951, 952, 953, 954, 955, 956, 957, 958, 959, 960, 961, 962, 963, 964, 965, 966, 967, 968, 969, 970, 971, 972, 973, 974, 975, 976, 977, 978, 979, 980, 981, 982, 983, 984, 985, 986, 987, 988, 989, 990, 991, 992, 993, 994, 995, 996, 997, 998, 999, 1000

MAIN CONTRACTOR :
Gammon

STRUCTURAL ENGINEER :
ARUP

FACADE CONSULTANT:
MEINHARDT

NOTE :
 1. ALL DIMENSIONS ARE IN mm.
 2. ALL ELEVATIONS ARE VIEWED FROM OUTSIDE.
 3. ALL DIMENSIONS TO BE VERIFIED ON SITE BEFORE FABRICATION.

LEGEND :
 (x1) — DETAIL MARK NO.
 (x001) — REFER SHEET NO.
 1. F.F.L. — FINISHED FLOOR LEVEL
 2. S.F.L. — STRUCTURAL FLOOR LEVEL
 3. (R) — REVERSED DETAIL

NO.	DATE	REVISION	BY
A	07/11/2020	REVISION SUBJECT TO ARCH.COMMENT	lvart

JOB NO. : J-852
 PROJECT :
 PROPOSED RESIDENTIAL DEVELOPMENT
 AT 139 - 147 ARGYLE STREET,
 NKIL 6005, 6035 R.P., 6036 R.P.,
 6037 R.P. & 6038 R.P.

TITLE :
 PART PLAN OF
 TOWER 3 (1/F)

DATE : 12-Dec-2019 SCALE : 1:150

DRAWN BY : MN CHECKED BY : DW

美特鋁質有限公司
MIDI ALUMINIUM FABRICATOR LTD.
 Units 6-8, Sunray Industrial Centre, 1/F
 610 Cha Kwo Ling Road, Kowloon
 Tel: 23489211-4 Fax: (852)27727666

DWG NO. : J852-SD-PB-3009 REV. : A



PLAN OF TOWER 3 (2/F~21F)

B.D. REF :

CLIENT :

ARCHITECT :
AGC DESIGN LTD
 161, 162, 163, 164, 165, 166, 167, 168, 169, 170, 171, 172, 173, 174, 175, 176, 177, 178, 179, 180, 181, 182, 183, 184, 185, 186, 187, 188, 189, 190, 191, 192, 193, 194, 195, 196, 197, 198, 199, 200, 201, 202, 203, 204, 205, 206, 207, 208, 209, 210, 211, 212, 213, 214, 215, 216, 217, 218, 219, 220, 221, 222, 223, 224, 225, 226, 227, 228, 229, 230, 231, 232, 233, 234, 235, 236, 237, 238, 239, 240, 241, 242, 243, 244, 245, 246, 247, 248, 249, 250, 251, 252, 253, 254, 255, 256, 257, 258, 259, 260, 261, 262, 263, 264, 265, 266, 267, 268, 269, 270, 271, 272, 273, 274, 275, 276, 277, 278, 279, 280, 281, 282, 283, 284, 285, 286, 287, 288, 289, 290, 291, 292, 293, 294, 295, 296, 297, 298, 299, 300, 301, 302, 303, 304, 305, 306, 307, 308, 309, 310, 311, 312, 313, 314, 315, 316, 317, 318, 319, 320, 321, 322, 323, 324, 325, 326, 327, 328, 329, 330, 331, 332, 333, 334, 335, 336, 337, 338, 339, 340, 341, 342, 343, 344, 345, 346, 347, 348, 349, 350, 351, 352, 353, 354, 355, 356, 357, 358, 359, 360, 361, 362, 363, 364, 365, 366, 367, 368, 369, 370, 371, 372, 373, 374, 375, 376, 377, 378, 379, 380, 381, 382, 383, 384, 385, 386, 387, 388, 389, 390, 391, 392, 393, 394, 395, 396, 397, 398, 399, 400, 401, 402, 403, 404, 405, 406, 407, 408, 409, 410, 411, 412, 413, 414, 415, 416, 417, 418, 419, 420, 421, 422, 423, 424, 425, 426, 427, 428, 429, 430, 431, 432, 433, 434, 435, 436, 437, 438, 439, 440, 441, 442, 443, 444, 445, 446, 447, 448, 449, 450, 451, 452, 453, 454, 455, 456, 457, 458, 459, 460, 461, 462, 463, 464, 465, 466, 467, 468, 469, 470, 471, 472, 473, 474, 475, 476, 477, 478, 479, 480, 481, 482, 483, 484, 485, 486, 487, 488, 489, 490, 491, 492, 493, 494, 495, 496, 497, 498, 499, 500, 501, 502, 503, 504, 505, 506, 507, 508, 509, 510, 511, 512, 513, 514, 515, 516, 517, 518, 519, 520, 521, 522, 523, 524, 525, 526, 527, 528, 529, 530, 531, 532, 533, 534, 535, 536, 537, 538, 539, 540, 541, 542, 543, 544, 545, 546, 547, 548, 549, 550, 551, 552, 553, 554, 555, 556, 557, 558, 559, 560, 561, 562, 563, 564, 565, 566, 567, 568, 569, 570, 571, 572, 573, 574, 575, 576, 577, 578, 579, 580, 581, 582, 583, 584, 585, 586, 587, 588, 589, 590, 591, 592, 593, 594, 595, 596, 597, 598, 599, 600, 601, 602, 603, 604, 605, 606, 607, 608, 609, 610, 611, 612, 613, 614, 615, 616, 617, 618, 619, 620, 621, 622, 623, 624, 625, 626, 627, 628, 629, 630, 631, 632, 633, 634, 635, 636, 637, 638, 639, 640, 641, 642, 643, 644, 645, 646, 647, 648, 649, 650, 651, 652, 653, 654, 655, 656, 657, 658, 659, 660, 661, 662, 663, 664, 665, 666, 667, 668, 669, 670, 671, 672, 673, 674, 675, 676, 677, 678, 679, 680, 681, 682, 683, 684, 685, 686, 687, 688, 689, 690, 691, 692, 693, 694, 695, 696, 697, 698, 699, 700, 701, 702, 703, 704, 705, 706, 707, 708, 709, 710, 711, 712, 713, 714, 715, 716, 717, 718, 719, 720, 721, 722, 723, 724, 725, 726, 727, 728, 729, 730, 731, 732, 733, 734, 735, 736, 737, 738, 739, 740, 741, 742, 743, 744, 745, 746, 747, 748, 749, 750, 751, 752, 753, 754, 755, 756, 757, 758, 759, 760, 761, 762, 763, 764, 765, 766, 767, 768, 769, 770, 771, 772, 773, 774, 775, 776, 777, 778, 779, 780, 781, 782, 783, 784, 785, 786, 787, 788, 789, 790, 791, 792, 793, 794, 795, 796, 797, 798, 799, 800, 801, 802, 803, 804, 805, 806, 807, 808, 809, 810, 811, 812, 813, 814, 815, 816, 817, 818, 819, 820, 821, 822, 823, 824, 825, 826, 827, 828, 829, 830, 831, 832, 833, 834, 835, 836, 837, 838, 839, 840, 841, 842, 843, 844, 845, 846, 847, 848, 849, 850, 851, 852, 853, 854, 855, 856, 857, 858, 859, 860, 861, 862, 863, 864, 865, 866, 867, 868, 869, 870, 871, 872, 873, 874, 875, 876, 877, 878, 879, 880, 881, 882, 883, 884, 885, 886, 887, 888, 889, 890, 891, 892, 893, 894, 895, 896, 897, 898, 899, 900, 901, 902, 903, 904, 905, 906, 907, 908, 909, 910, 911, 912, 913, 914, 915, 916, 917, 918, 919, 920, 921, 922, 923, 924, 925, 926, 927, 928, 929, 930, 931, 932, 933, 934, 935, 936, 937, 938, 939, 940, 941, 942, 943, 944, 945, 946, 947, 948, 949, 950, 951, 952, 953, 954, 955, 956, 957, 958, 959, 960, 961, 962, 963, 964, 965, 966, 967, 968, 969, 970, 971, 972, 973, 974, 975, 976, 977, 978, 979, 980, 981, 982, 983, 984, 985, 986, 987, 988, 989, 990, 991, 992, 993, 994, 995, 996, 997, 998, 999, 1000

MAIN CONTRACTOR :
Gammon

STRUCTURAL ENGINEER :
ARUP

FACADE CONSULTANT:
MEINHARDT

NOTE :
 1. ALL DIMENSIONS ARE IN mm.
 2. ALL ELEVATIONS ARE VIEWED FROM OUTSIDE.
 3. ALL DIMENSIONS TO BE VERIFIED ON SITE BEFORE FABRICATION.

LEGEND :
 (X1) --- DETAIL MARK NO.
 (X001) --- REFER SHEET NO.
 1. F.F.L. --- FINISHED FLOOR LEVEL
 2. S.F.L. --- STRUCTURAL FLOOR LEVEL
 3. (R) --- REVERSED DETAIL

NO.	DATE	REVISION	BY
A	07/11/2020	REVISION SUBJECT TO ARCH.COMMENT	lvart

JOB NO. : J-852
 PROJECT :
 PROPOSED RESIDENTIAL DEVELOPMENT
 AT 139 - 147 ARGYLE STREET,
 NKIL 6005, 6035 R.P., 6036 R.P.,
 6037 R.P. & 6038 R.P.

TITLE :
 PART PLAN OF
 TOWER 3 (2-21/F)

DATE : 12-Dec-2019 SCALE : 1:150

DRAWN BY : MN CHECKED BY : DW

美特鋁質有限公司
MIDI ALUMINIUM FABRICATOR LTD.
 Units 6-8, Sunray Industrial Centre, 1/F
 610 Cha Kwo Ling Road, Kowloon
 Tel: 23489211-4 Fax: (852)2727666

DWG NO. : J852-SD-PB-3010 REV. : A

B.D. REF :

CLIENT :

ARCHITECT :
AGC DESIGN LTD
AGC DESIGN LTD
 100, 14/F, Dynasty Plaza, 225, King's Road, North Point, Hong Kong
 Tel: (852)2779788, Fax: (852)2779789, Email: agc@agc.com.hk

MAIN CONTRACTOR :
Gammon

STRUCTURAL ENGINEER :
ARUP

FACADE CONSULTANT:
MEINHARDT

NOTE :
 1. ALL DIMENSIONS ARE IN mm.
 2. ALL ELEVATIONS ARE VIEWED FROM OUTSIDE.
 3. ALL DIMENSIONS TO BE VERIFIED ON SITE BEFORE FABRICATION.

LEGEND :
 X1 --- DETAIL MARK NO.
 X001 --- REFER SHEET NO.
 1. F.F.L. --- FINISHED FLOOR LEVEL
 2. S.F.L. --- STRUCTURAL FLOOR LEVEL
 3. (R) --- REVERSED DETAIL
 4. ▲ --- FIXING LOCATION
 5. △ --- FIXING LUG LOCATION
 6. GLASS LEGEND
 GL01 --- 8mm+12mm AIR GAP+10mm THK. I.G.U.
 GL01a --- 8mm+9mm AIR GAP+12mm THK. I.G.U.
 GL03 --- 6mm+12mm AIR GAP+6mm THK. I.G.U.
 GL04 --- 10mm THK. TEMPERED GLASS (PROTECTIVE BARRIER)
 GL05 --- 6mm+12mm AIR GAP+8mm THK. I.G.U.

A	07/11/2020	REVISION SUBJECT TO ARCH.COMMENT	Ivan
NO.	DATE	REVISED	BY

JOB NO. : J-852
 PROJECT :
 PROPOSED RESIDENTIAL DEVELOPMENT
 AT 139 - 147 ARGYLE STREET,
 NKIL 6005, 6035 R.P., 6036 R.P.,
 6037 R.P. & 6038 R.P.

TITLE :
 SCHEDULE FOR Plenum Box
 AT TOWER 1 (1-21F)

DATE : 05-Dec-19 SCALE : 1:40
 DRAWN BY : MN CHECKED BY : DW

美特鋁質有限公司
MIDI ALUMINIUM FABRICATOR LTD.
 Units 6-8, Sunray Industrial Centre, 1/F
 610 Cha Kwo Ling Road, Kowloon
 Tel:23489211-4 Fax:(852)27727666

DWG NO. : J852-SD-PB-4101 REV. : A

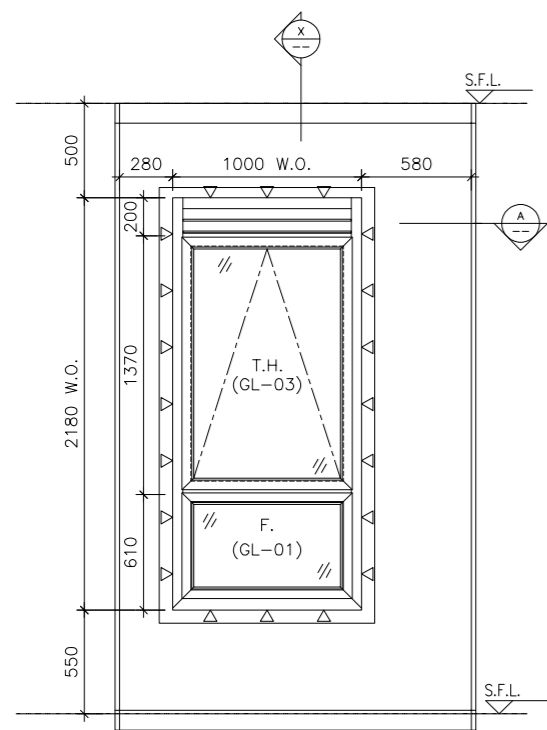

ELEVATION

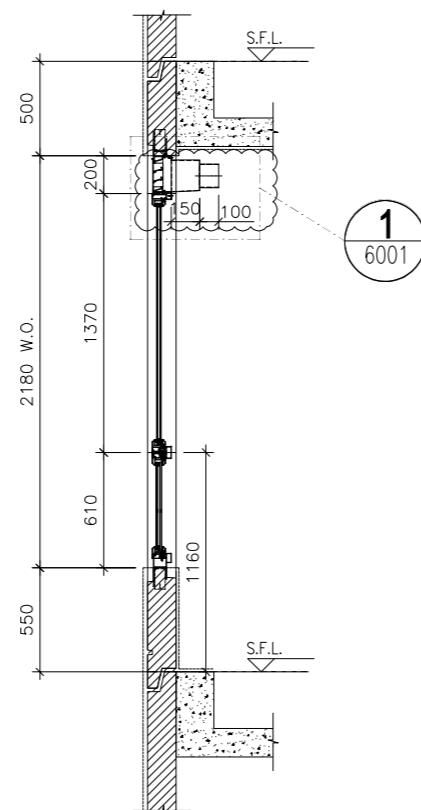

SECTION "X-X"

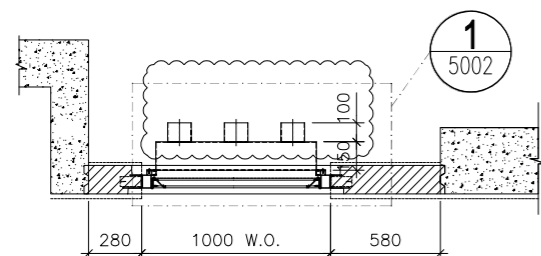

PART PLAN A

ELEVATION

WINDOW MARK

W4
T1A

LOCATION 1/F-20/F M.B. AT TOWER 1 FLAT A
 SECTION 70mm ALUM. SECTION
 GLAZING GL-01, GL-03
 QUANTITY 17
 REMARKS FACADE (PF-15)

ELEVATION

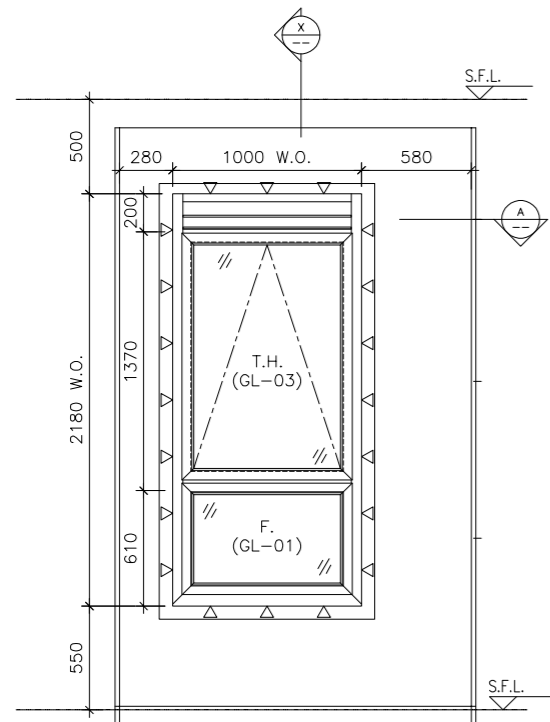

ELEVATION

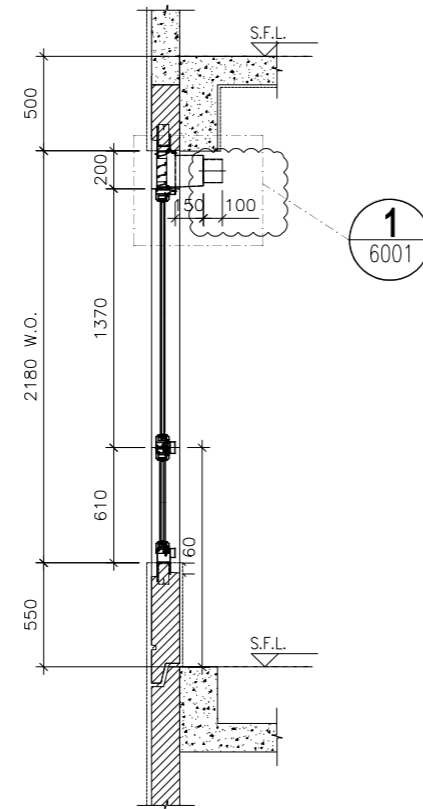

SECTION "X-X"

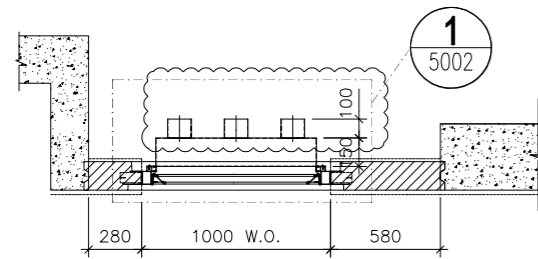

PART PLAN A

WINDOW MARK

W4
T1A

LOCATION 21/F M.B. AT TOWER 1 FLAT A

SECTION 70mm ALUM. SECTION

GLAZING GL-01, GL-03

QUANTITY 1

REMARKS FACADE (PF-15)

B.D. REF :

CLIENT :

ARCHITECT :

AGC
DESIGN LTD

MAIN CONTRACTOR :

Gammon

STRUCTURAL ENGINEER :

ARUP

FACADE CONSULTANT:

MEINHARDT

NOTE :

1. ALL DIMENSIONS ARE IN mm.
2. ALL ELEVATIONS ARE VIEWED FROM OUTSIDE.
3. ALL DIMENSIONS TO BE VERIFIED ON SITE BEFORE FABRICATION.

LEGEND :

- X1 --- DETAIL MARK NO.
- X001 --- REFER SHEET NO.

1. F.F.L. -- FINISHED FLOOR LEVEL
2. S.F.L. -- STRUCTURAL FLOOR LEVEL
3. (R) -- REVERSED DETAIL
4. ▲ -- FIXING LOCATION
5. △ -- FIXING LUG LOCATION

6. GLASS LEGEND
- GL01 -- 8mm+12mm AIR GAP+10mm THK. I.G.U.
 - GL01a -- 8mm+9mm AIR GAP+12mm THK. I.G.U.
 - GL03 -- 6mm+12mm AIR GAP+6mm THK. I.G.U.
 - GL04 -- 10mm THK. TEMPERED GLASS (PROTECTIVE BARRIER)
 - GL05 -- 6mm+12mm AIR GAP+8mm THK. I.G.U.

NO.	DATE	REVISION SUBJECT TO ARCH.COMMENT	BY
A	07/11/2020	REVISION SUBJECT TO ARCH.COMMENT	Ivan

JOB NO. : J-852

PROJECT :
PROPOSED RESIDENTIAL DEVELOPMENT
AT 139 - 147 ARGYLE STREET,
NKIL 6005, 6035 R.P., 6036 R.P.,
6037 R.P. & 6038 R.P.

TITLE :
SCHEDULE FOR Plenum Box
AT TOWER 1 (1-21F)

DATE : 22-Apr-20 SCALE : 1:40

DRAWN BY : MN CHECKED BY : DW

美特鋁質有限公司
MIDI ALUMINIUM FABRICATOR LTD.
Units 6-8, Sunray Industrial Centre, 1/F
610 Cha Kwo Ling Road, Kowloon
Tel:23489211-4 Fax:(852)27727666

DWG NO. : J852-SD-PB-4101A REV. : A

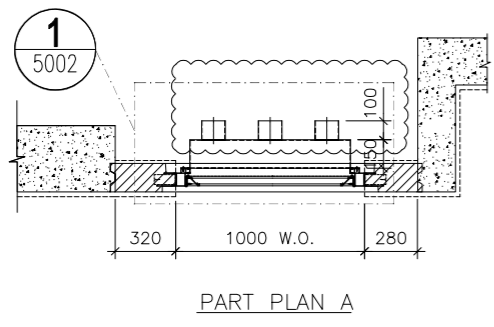
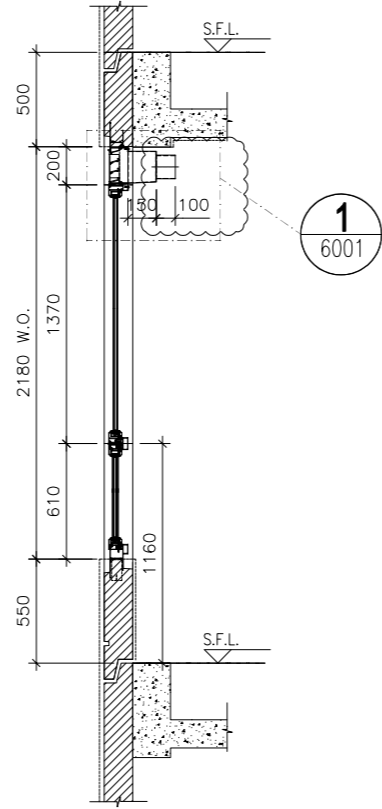
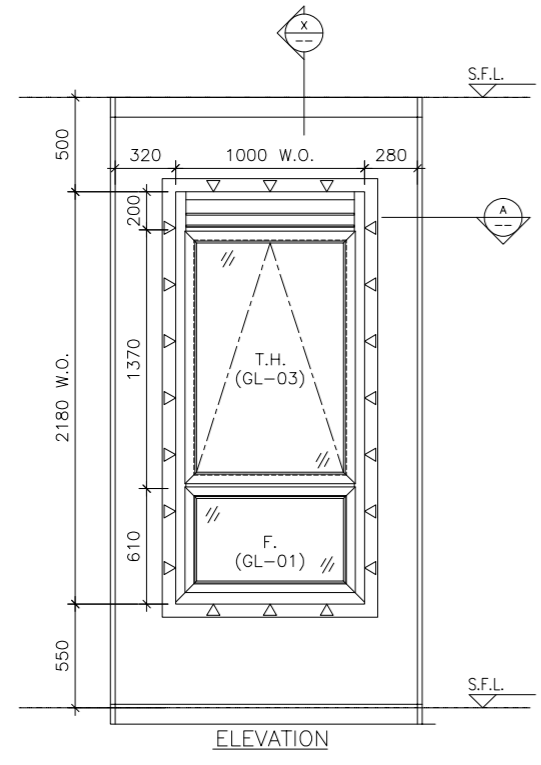

ELEVATION

WINDOW MARK	W5 T1A
LOCATION	1/F-20/F EN.B. AT TOWER 1 FLAT A
SECTION	70mm ALUM. SECTION
GLAZING	GL-01, GL-03
QUANTITY	17
REMARKS	FACADE (PF-16)

B.D. REF :

CLIENT :

ARCHITECT :

AGC DESIGN LTD

100, 14/F, Ocean Plaza, 225, King's Road, North Point, Hong Kong
Tel: (852) 2779788, Fax: (852) 2779733, Email: agc@agc.com.hk

MAIN CONTRACTOR :

Gammon

STRUCTURAL ENGINEER :

ARUP

FACADE CONSULTANT:

MEINHARDT

- NOTE :
- ALL DIMENSIONS ARE IN mm.
 - ALL ELEVATIONS ARE VIEWED FROM OUTSIDE.
 - ALL DIMENSIONS TO BE VERIFIED ON SITE BEFORE FABRICATION.
- LEGEND :
- X1 --- DETAIL MARK NO.
 - X001 --- REFER SHEET NO.
 - 1. F.F.L. --- FINISHED FLOOR LEVEL
 - 2. S.F.L. --- STRUCTURAL FLOOR LEVEL
 - 3. (R) --- REVERSED DETAIL
 - 4. ▲ --- FIXING LOCATION
 - 5. △ --- FIXING LUG LOCATION
 - 6. GLASS LEGEND
 - GL01 --- 8mm+12mm AIR GAP+10mm THK. I.G.U.
 - GL01a --- 8mm+9mm AIR GAP+12mm THK. I.G.U.
 - GL03 --- 6mm+12mm AIR GAP+6mm THK. I.G.U.
 - GL04 --- 10mm THK. TEMPERED GLASS (PROTECTIVE BARRIER)
 - GL05 --- 6mm+12mm AIR GAP+8mm THK. I.G.U.

NO.	DATE	REVISION SUBJECT TO ARCH.COMMENT	REVISOR	BY
A	07/11/2020	REVISION SUBJECT TO ARCH.COMMENT		Ivan

JOB NO. : J-852

PROJECT : PROPOSED RESIDENTIAL DEVELOPMENT AT 139 - 147 ARGYLE STREET, NKIL 6005, 6035 R.P., 6036 R.P., 6037 R.P. & 6038 R.P.

TITLE : SCHEDULE FOR Plenum Box AT TOWER 1 (1-21F)

DATE : 05-Dec-19 SCALE : 1:40

DRAWN BY : MN CHECKED BY : DW

美特鋁質有限公司
MIDI ALUMINIUM FABRICATOR LTD.
 Units 6-8, Sunray Industrial Centre, 1/F
 610 Cha Kwo Ling Road, Kowloon
 Tel: 23489211-4 Fax: (852) 27727666

DWG NO. : J852-SD-PB-4102 REV. : A

ELEVATION

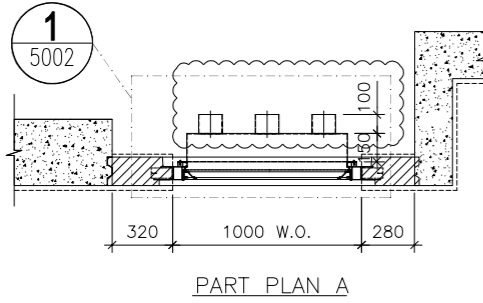
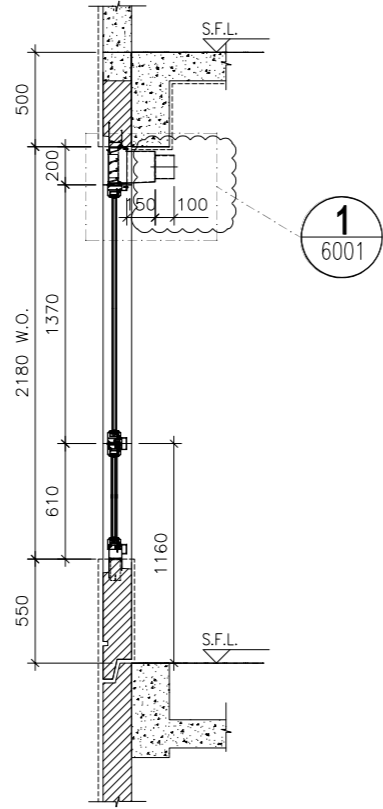
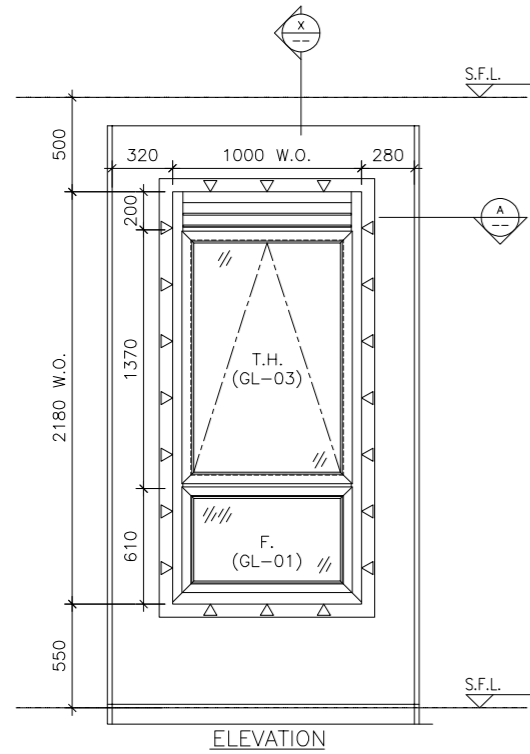

WINDOW MARK



LOCATION

21/F EN.B. AT TOWER 1 FLAT A

SECTION

70mm ALUM. SECTION

GLAZING

GL-01, GL-03

QUANTITY

1

REMARKS

FACADE (PF-16)

B.D. REF :

CLIENT :

ARCHITECT :
AGC DESIGN LTD
 1005, 14/F, Dynasty Plaza, 225, King's Road, North Point, Hong Kong
 Tel: (852)27797882, Fax: (852)27797823, Email: agc@agc.com.hk

MAIN CONTRACTOR :
Gammon

STRUCTURAL ENGINEER :
ARUP

FACADE CONSULTANT:
MEINHARDT

NOTE :
 1. ALL DIMENSIONS ARE IN mm.
 2. ALL ELEVATIONS ARE VIEWED FROM OUTSIDE.
 3. ALL DIMENSIONS TO BE VERIFIED ON SITE BEFORE FABRICATION.

LEGEND :
 X1 --- DETAIL MARK NO.
 X001 --- REFER SHEET NO.
 1. F.F.L. --- FINISHED FLOOR LEVEL
 2. S.F.L. --- STRUCTURAL FLOOR LEVEL
 3. (R) --- REVERSED DETAIL
 4. ▲ --- FIXING LOCATION
 5. △ --- FIXING LUG LOCATION
 6. GLASS LEGEND
 GL01 --- 8mm+12mm AIR GAP+10mm THK. I.G.U.
 GL01a --- 8mm+9mm AIR GAP+12mm THK. I.G.U.
 GL03 --- 6mm+12mm AIR GAP+6mm THK. I.G.U.
 GL04 --- 10mm THK. TEMPERED GLASS (PROTECTIVE BARRIER)
 GL05 --- 6mm+12mm AIR GAP+8mm THK. I.G.U.

A	07/11/2020	REVISION SUBJECT TO ARCH.COMMENT	Ivan
NO.	DATE	REVISED	BY

JOB NO. : J-852
 PROJECT :
 PROPOSED RESIDENTIAL DEVELOPMENT
 AT 139 - 147 ARGYLE STREET,
 NKIL 6005, 6035 R.P., 6036 R.P.,
 6037 R.P. & 6038 R.P.

TITLE :
 SCHEDULE FOR Plenum Box
 AT TOWER 1 (1-21F)

DATE : 22-Apr-20 SCALE : 1:40
 DRAWN BY : MN CHECKED BY : DW

美特鋁質有限公司
MIDI ALUMINIUM FABRICATOR LTD.
 Units 6-8, Sunray Industrial Centre, 1/F
 610 Cha Kwo Ling Road, Kowloon
 Tel:23489211-4 Fax:(852)27727666

DWG NO. : J852-SD-PB-4102A REV. : A

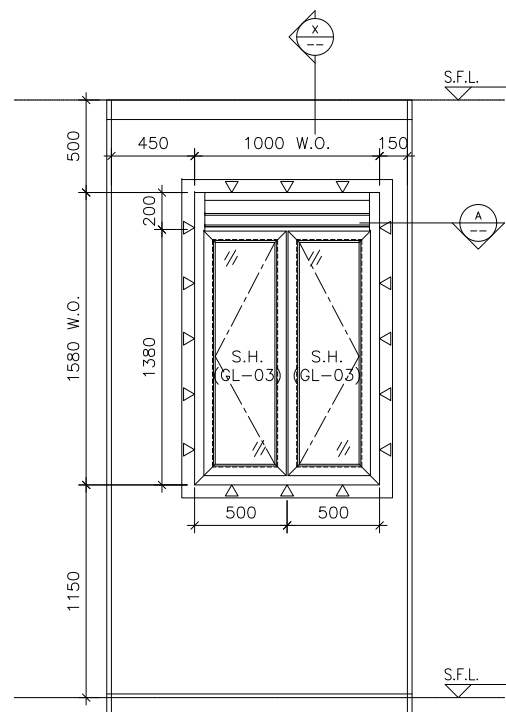

ELEVATION

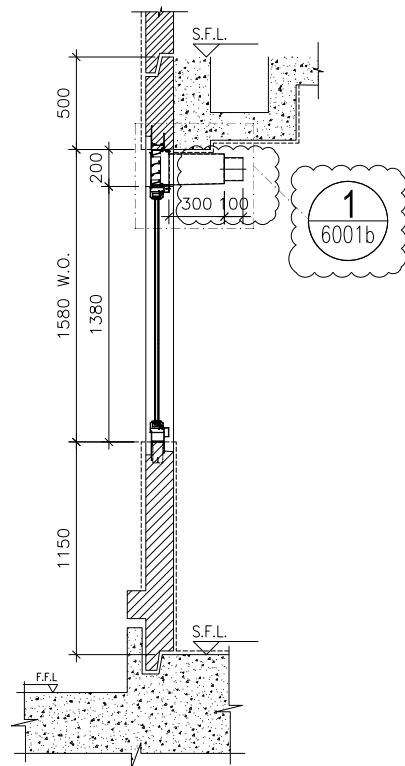

SECTION "X-X"

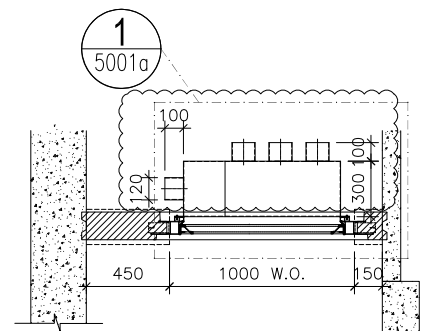

PART PLAN A

ELEVATION

WINDOW MARK



LOCATION 1/F KIT. AT TOWER 1 FLAT C

SECTION 70mm ALUM. SECTION

GLAZING GL-03

QUANTITY 1

REMARKS FACADE (PF-31)

B.D. REF :

CLIENT :

ARCHITECT :

AGC
DESIGN LTD

MAIN CONTRACTOR :

Gammon

STRUCTURAL ENGINEER :

ARUP

FACADE CONSULTANT:

MEINHARDT

NOTE :

1. ALL DIMENSIONS ARE IN mm.
2. ALL ELEVATIONS ARE VIEWED FROM OUTSIDE.
3. ALL DIMENSIONS TO BE VERIFIED ON SITE BEFORE FABRICATION.

LEGEND :

- x1 --- DETAIL MARK NO.
- x001 --- REFER SHEET NO.

1. F.F.L. --- FINISHED FLOOR LEVEL
2. S.F.L. --- STRUCTURAL FLOOR LEVEL
3. (R) --- REVERSED DETAIL
4. ▲ --- FIXING LOCATION
5. △ --- FIXING LUG LOCATION

6. GLASS LEGEND

- GL01 --- 8mm+12mm AIR GAP+10mm THK. I.G.U.
- GL01a --- 8mm+9mm AIR GAP+12mm THK. I.G.U.
- GL03 --- 6mm+12mm AIR GAP+6mm THK. I.G.U.
- GL04 --- 10mm THK. TEMPERED GLASS (PROTECTIVE BARRIER)
- GL05 --- 6mm+12mm AIR GAP+8mm THK. I.G.U.

NO.	DATE	REVISION	BY
A	09/12/2020	REVISION SUBJECT TO ARCH.COMMENT	lvac

JOB NO. : J-852

PROJECT :
PROPOSED RESIDENTIAL DEVELOPMENT
AT 139 - 147 ARGYLE STREET,
NKIL 6005, 6035 R.P., 6036 R.P.,
6037 R.P. & 6038 R.P.

TITLE :
SCHEDULE FOR Plenum Box
AT TOWER 1 (1-21F)

DATE : 22-Apr-20 SCALE : 1:40

DRAWN BY : MN CHECKED BY : DW

美特鋁質有限公司
MIDI ALUMINIUM FABRICATOR LTD.
Units 6-8, Sunray Industrial Centre, 1/F
610 Cha Kwo Ling Road, Kowloon
Tel:23489211-4 Fax:(852)2727666

DWG NO. : J852-SD-PB-4103 REV. : A

ELEVATION

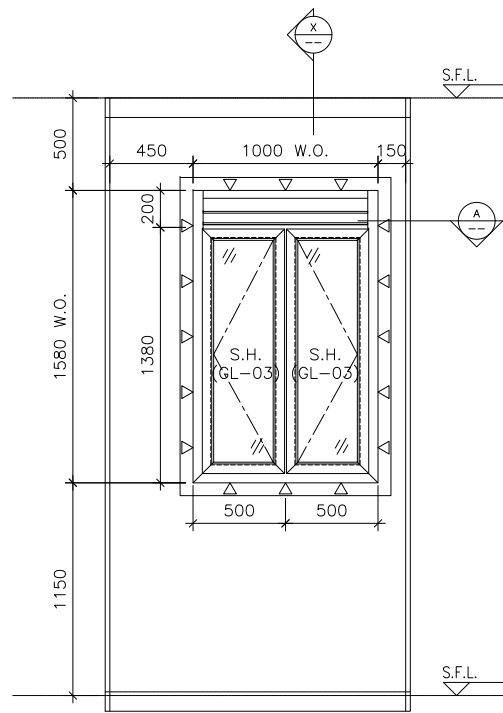

ELEVATION

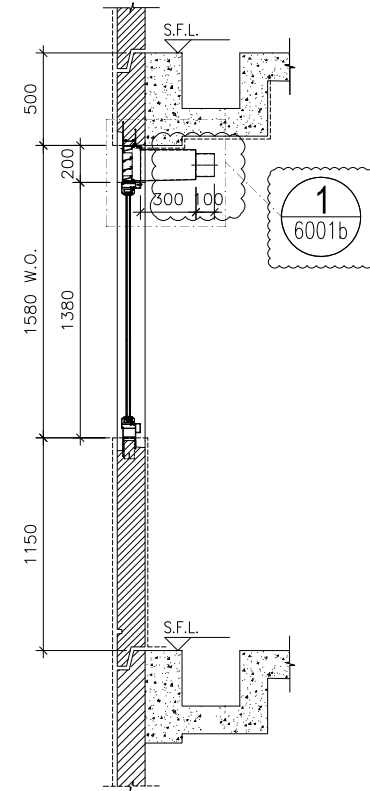

SECTION "X-X"

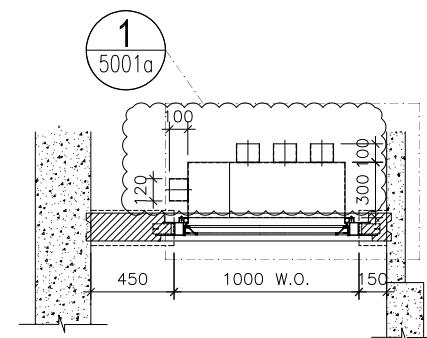

PART PLAN A

WINDOW MARK



LOCATION 2/F-21/F KIT. AT TOWER 1 FLAT C

SECTION 70mm ALUM. SECTION

GLAZING GL-03

QUANTITY 17

REMARKS FACADE (PF-31)

B.D. REF :

CLIENT :

ARCHITECT :
AGC DESIGN LTD
 101, 102, 103, 104, 105, 106, 107, 108, 109, 110, 111, 112, 113, 114, 115, 116, 117, 118, 119, 120, 121, 122, 123, 124, 125, 126, 127, 128, 129, 130, 131, 132, 133, 134, 135, 136, 137, 138, 139, 140, 141, 142, 143, 144, 145, 146, 147, 148, 149, 150, 151, 152, 153, 154, 155, 156, 157, 158, 159, 160, 161, 162, 163, 164, 165, 166, 167, 168, 169, 170, 171, 172, 173, 174, 175, 176, 177, 178, 179, 180, 181, 182, 183, 184, 185, 186, 187, 188, 189, 190, 191, 192, 193, 194, 195, 196, 197, 198, 199, 200, 201, 202, 203, 204, 205, 206, 207, 208, 209, 210, 211, 212, 213, 214, 215, 216, 217, 218, 219, 220, 221, 222, 223, 224, 225, 226, 227, 228, 229, 230, 231, 232, 233, 234, 235, 236, 237, 238, 239, 240, 241, 242, 243, 244, 245, 246, 247, 248, 249, 250, 251, 252, 253, 254, 255, 256, 257, 258, 259, 260, 261, 262, 263, 264, 265, 266, 267, 268, 269, 270, 271, 272, 273, 274, 275, 276, 277, 278, 279, 280, 281, 282, 283, 284, 285, 286, 287, 288, 289, 290, 291, 292, 293, 294, 295, 296, 297, 298, 299, 300, 301, 302, 303, 304, 305, 306, 307, 308, 309, 310, 311, 312, 313, 314, 315, 316, 317, 318, 319, 320, 321, 322, 323, 324, 325, 326, 327, 328, 329, 330, 331, 332, 333, 334, 335, 336, 337, 338, 339, 340, 341, 342, 343, 344, 345, 346, 347, 348, 349, 350, 351, 352, 353, 354, 355, 356, 357, 358, 359, 360, 361, 362, 363, 364, 365, 366, 367, 368, 369, 370, 371, 372, 373, 374, 375, 376, 377, 378, 379, 380, 381, 382, 383, 384, 385, 386, 387, 388, 389, 390, 391, 392, 393, 394, 395, 396, 397, 398, 399, 400, 401, 402, 403, 404, 405, 406, 407, 408, 409, 410, 411, 412, 413, 414, 415, 416, 417, 418, 419, 420, 421, 422, 423, 424, 425, 426, 427, 428, 429, 430, 431, 432, 433, 434, 435, 436, 437, 438, 439, 440, 441, 442, 443, 444, 445, 446, 447, 448, 449, 450, 451, 452, 453, 454, 455, 456, 457, 458, 459, 460, 461, 462, 463, 464, 465, 466, 467, 468, 469, 470, 471, 472, 473, 474, 475, 476, 477, 478, 479, 480, 481, 482, 483, 484, 485, 486, 487, 488, 489, 490, 491, 492, 493, 494, 495, 496, 497, 498, 499, 500, 501, 502, 503, 504, 505, 506, 507, 508, 509, 510, 511, 512, 513, 514, 515, 516, 517, 518, 519, 520, 521, 522, 523, 524, 525, 526, 527, 528, 529, 530, 531, 532, 533, 534, 535, 536, 537, 538, 539, 540, 541, 542, 543, 544, 545, 546, 547, 548, 549, 550, 551, 552, 553, 554, 555, 556, 557, 558, 559, 560, 561, 562, 563, 564, 565, 566, 567, 568, 569, 570, 571, 572, 573, 574, 575, 576, 577, 578, 579, 580, 581, 582, 583, 584, 585, 586, 587, 588, 589, 590, 591, 592, 593, 594, 595, 596, 597, 598, 599, 600, 601, 602, 603, 604, 605, 606, 607, 608, 609, 610, 611, 612, 613, 614, 615, 616, 617, 618, 619, 620, 621, 622, 623, 624, 625, 626, 627, 628, 629, 630, 631, 632, 633, 634, 635, 636, 637, 638, 639, 640, 641, 642, 643, 644, 645, 646, 647, 648, 649, 650, 651, 652, 653, 654, 655, 656, 657, 658, 659, 660, 661, 662, 663, 664, 665, 666, 667, 668, 669, 670, 671, 672, 673, 674, 675, 676, 677, 678, 679, 680, 681, 682, 683, 684, 685, 686, 687, 688, 689, 690, 691, 692, 693, 694, 695, 696, 697, 698, 699, 700, 701, 702, 703, 704, 705, 706, 707, 708, 709, 710, 711, 712, 713, 714, 715, 716, 717, 718, 719, 720, 721, 722, 723, 724, 725, 726, 727, 728, 729, 730, 731, 732, 733, 734, 735, 736, 737, 738, 739, 740, 741, 742, 743, 744, 745, 746, 747, 748, 749, 750, 751, 752, 753, 754, 755, 756, 757, 758, 759, 760, 761, 762, 763, 764, 765, 766, 767, 768, 769, 770, 771, 772, 773, 774, 775, 776, 777, 778, 779, 780, 781, 782, 783, 784, 785, 786, 787, 788, 789, 790, 791, 792, 793, 794, 795, 796, 797, 798, 799, 800, 801, 802, 803, 804, 805, 806, 807, 808, 809, 810, 811, 812, 813, 814, 815, 816, 817, 818, 819, 820, 821, 822, 823, 824, 825, 826, 827, 828, 829, 830, 831, 832, 833, 834, 835, 836, 837, 838, 839, 840, 841, 842, 843, 844, 845, 846, 847, 848, 849, 850, 851, 852, 853, 854, 855, 856, 857, 858, 859, 860, 861, 862, 863, 864, 865, 866, 867, 868, 869, 870, 871, 872, 873, 874, 875, 876, 877, 878, 879, 880, 881, 882, 883, 884, 885, 886, 887, 888, 889, 890, 891, 892, 893, 894, 895, 896, 897, 898, 899, 900, 901, 902, 903, 904, 905, 906, 907, 908, 909, 910, 911, 912, 913, 914, 915, 916, 917, 918, 919, 920, 921, 922, 923, 924, 925, 926, 927, 928, 929, 930, 931, 932, 933, 934, 935, 936, 937, 938, 939, 940, 941, 942, 943, 944, 945, 946, 947, 948, 949, 950, 951, 952, 953, 954, 955, 956, 957, 958, 959, 960, 961, 962, 963, 964, 965, 966, 967, 968, 969, 970, 971, 972, 973, 974, 975, 976, 977, 978, 979, 980, 981, 982, 983, 984, 985, 986, 987, 988, 989, 990, 991, 992, 993, 994, 995, 996, 997, 998, 999, 1000

MAIN CONTRACTOR :
Gammon

STRUCTURAL ENGINEER :
ARUP

FACADE CONSULTANT:
MEINHARDT

NOTE :
 1. ALL DIMENSIONS ARE IN mm.
 2. ALL ELEVATIONS ARE VIEWED FROM OUTSIDE.
 3. ALL DIMENSIONS TO BE VERIFIED ON SITE BEFORE FABRICATION.

LEGEND :
 (X1) --- DETAIL MARK NO.
 (X001) --- REFER SHEET NO.
 1. F.F.L. --- FINISHED FLOOR LEVEL
 2. S.F.L. --- STRUCTURAL FLOOR LEVEL
 3. (R) --- REVERSED DETAIL
 4. (▲) --- FIXING LOCATION
 5. (△) --- FIXING LUG LOCATION
 6. GLASS LEGEND
 GL01 --- 8mm+12mm AIR GAP+10mm THK. I.G.U.
 GL01a --- 8mm+9mm AIR GAP+12mm THK. I.G.U.
 GL03 --- 6mm+12mm AIR GAP+6mm THK. I.G.U.
 GL04 --- 10mm THK. TEMPERED GLASS (PROTECTIVE BARRIER)
 GL05 --- 6mm+12mm AIR GAP+8mm THK. I.G.U.

NO.	DATE	REVISION	BY
A	09/12/2020	REVISION SUBJECT TO ARCH.COMMENT	Ivan

JOB NO. : J-852
 PROJECT :
 PROPOSED RESIDENTIAL DEVELOPMENT
 AT 139 - 147 ARGYLE STREET,
 NKIL 6005, 6035 R.P., 6036 R.P.,
 6037 R.P. & 6038 R.P.

TITLE :
 SCHEDULE FOR Plenum Box
 AT TOWER 1 (1-21F)

DATE : 05-Dec-19 SCALE : 1:40
 DRAWN BY : MN CHECKED BY : DW

美特鋁質有限公司
MIDI ALUMINIUM FABRICATOR LTD.
 Units 6-8, Sunray Industrial Centre, 1/F
 610 Cha Kwo Ling Road, Kowloon
 Tel:23489211-4 Fax:(852)2727666
 DWG NO. : J852-SD-PB-4103A REV. : A

B.D. REF :

CLIENT :

ARCHITECT :
AGC DESIGN LTD
 100, 14/F, D'Amor Plaza, 255 King's Road, North Point, Hong Kong
 Tel: (852) 25797882, Fax: (852) 25797833, Email: agc@agc.com.hk

MAIN CONTRACTOR :
Gammon

STRUCTURAL ENGINEER :
ARUP

FACADE CONSULTANT:
MEINHARDT

NOTE :
 1. ALL DIMENSIONS ARE IN mm.
 2. ALL ELEVATIONS ARE VIEWED FROM OUTSIDE.
 3. ALL DIMENSIONS TO BE VERIFIED ON SITE BEFORE FABRICATION.

LEGEND :
 X1 --- DETAIL MARK NO.
 X001 --- REFER SHEET NO.
 1. F.F.L. --- FINISHED FLOOR LEVEL
 2. S.F.L. --- STRUCTURAL FLOOR LEVEL
 3. (R) --- REVERSED DETAIL
 4. ▲ --- FIXING LOCATION
 5. △ --- FIXING LUG LOCATION
 6. GLASS LEGEND
 GL01 --- 8mm+12mm AIR GAP+10mm THK. I.G.U.
 GL01a --- 8mm+9mm AIR GAP+12mm THK. I.G.U.
 GL03 --- 6mm+12mm AIR GAP+6mm THK. I.G.U.
 GL04 --- 10mm THK. TEMPERED GLASS (PROTECTIVE BARRIER)
 GL05 --- 6mm+12mm AIR GAP+8mm THK. I.G.U.

A	07/11/2020	REVISION SUBJECT TO ARCH.COMMENT	Ivan
NO.	DATE	REVISED	BY

JOB NO. : J-852
 PROJECT : PROPOSED RESIDENTIAL DEVELOPMENT AT 139 - 147 ARGYLE STREET, NKIL 6005, 6035 R.P., 6036 R.P., 6037 R.P. & 6038 R.P.

TITLE : SCHEDULE FOR Plenum Box AT TOWER 1 (1-21F)

DATE : 22-Apr-20 SCALE : 1:40
 DRAWN BY : MN CHECKED BY : DW

美特鋁質有限公司
MIDI ALUMINIUM FABRICATOR LTD.
 Units 6-8, Sunray Industrial Centre, 1/F
 610 Cha Kwo Ling Road, Kowloon
 Tel: 23489211-4 Fax: (852) 27727666

DWG NO. : J852-SD-PB-4104 REV. : A

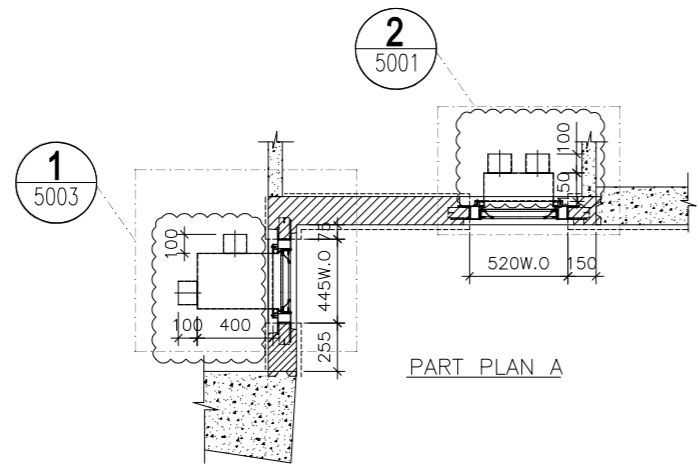
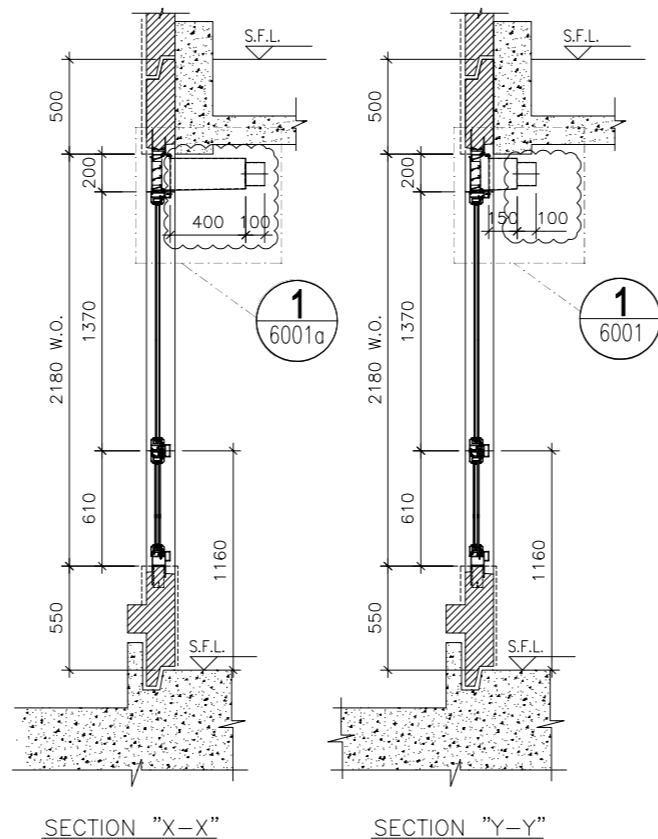
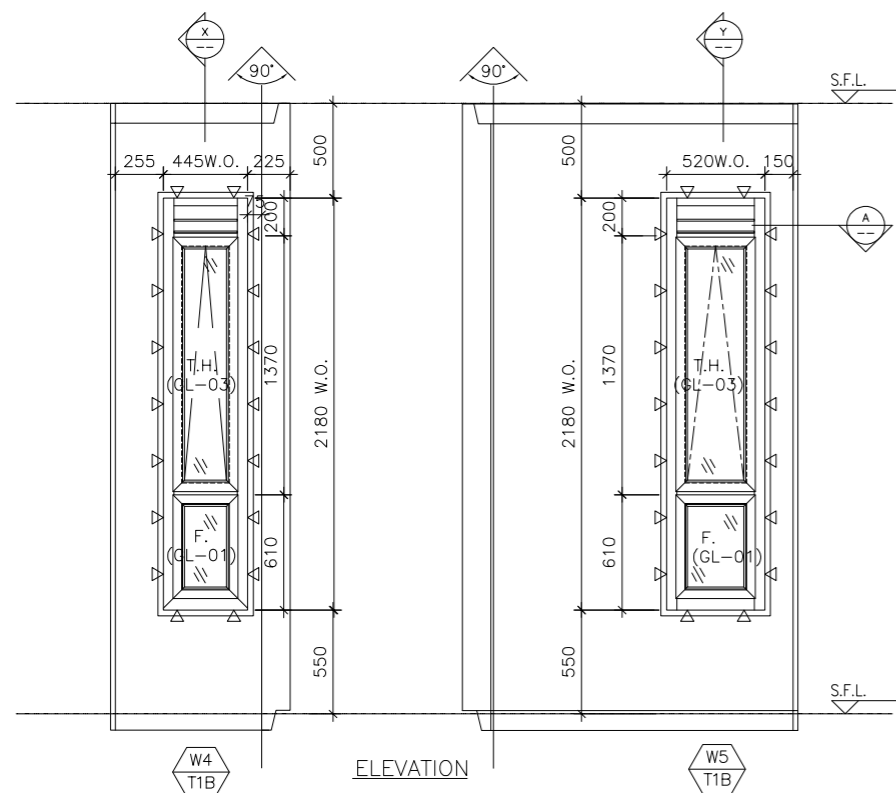

ELEVATION

WINDOW MARK **W5 / W4**
T1B / T1B

LOCATION 1/F M.B. & EN.B. AT TOWER 1 FLAT B
 SECTION 70mm ALUM. SECTION
 GLAZING GL-01, GL-03
 QUANTITY 1 / 1
 REMARKS FACADE (PF-37)

B.D. REF :

CLIENT :

ARCHITECT :
AGC DESIGN LTD
AGC DESIGN LTD, 205, King's Road, North Point, Hong Kong
 Tel: (852) 25191812, Fax: (852) 25191133, Email: agc@agc.com.hk

MAIN CONTRACTOR :
Gammon

STRUCTURAL ENGINEER :
ARUP

FACADE CONSULTANT:
MEINHARDT

NOTE :
 1. ALL DIMENSIONS ARE IN mm.
 2. ALL ELEVATIONS ARE VIEWED FROM OUTSIDE.
 3. ALL DIMENSIONS TO BE VERIFIED ON SITE BEFORE FABRICATION.

LEGEND :
 X1 --- DETAIL MARK NO.
 X001 --- REFER SHEET NO.
 1. F.F.L. --- FINISHED FLOOR LEVEL
 2. S.F.L. --- STRUCTURAL FLOOR LEVEL
 3. (R) --- REVERSED DETAIL
 4. ▲ --- FIXING LOCATION
 5. △ --- FIXING LUG LOCATION
 6. GLASS LEGEND
 GL01 --- 8mm+12mm AIR GAP+10mm THK. I.G.U.
 GL01a --- 8mm+9mm AIR GAP+12mm THK. I.G.U.
 GL03 --- 6mm+12mm AIR GAP+6mm THK. I.G.U.
 GL04 --- 10mm THK. TEMPERED GLASS (PROTECTIVE BARRIER)
 GL05 --- 6mm+12mm AIR GAP+8mm THK. I.G.U.

A	07/11/2020	REVISION SUBJECT TO ARCH.COMMENT	Ivan
NO.	DATE	REVISED	BY

JOB NO. : J-852
 PROJECT :
 PROPOSED RESIDENTIAL DEVELOPMENT
 AT 139 - 147 ARGYLE STREET,
 NKIL 6005, 6035 R.P., 6036 R.P.,
 6037 R.P. & 6038 R.P.
 TITLE :
 SCHEDULE FOR Plenum Box
 AT TOWER 1 (1-21F)

DATE : 22-Apr-20 SCALE : 1:40
 DRAWN BY : MN CHECKED BY : DW

美特鋁質有限公司
MIDI ALUMINIUM FABRICATOR LTD.
 Units 6-8, Sunray Industrial Centre, 1/F
 610 Cha Kwo Ling Road, Kowloon
 Tel: 23489211-4 Fax: (852) 2727666
 DWG NO. : J852-SD-PB-4104A REV. : A

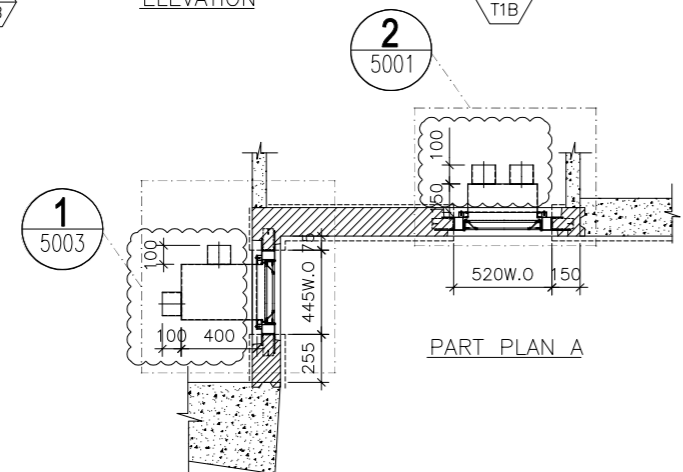
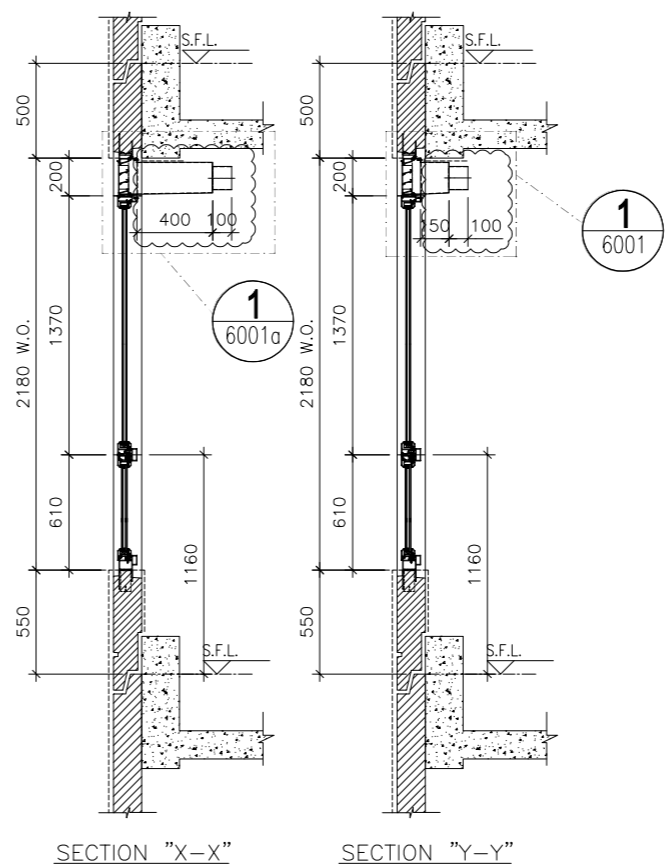
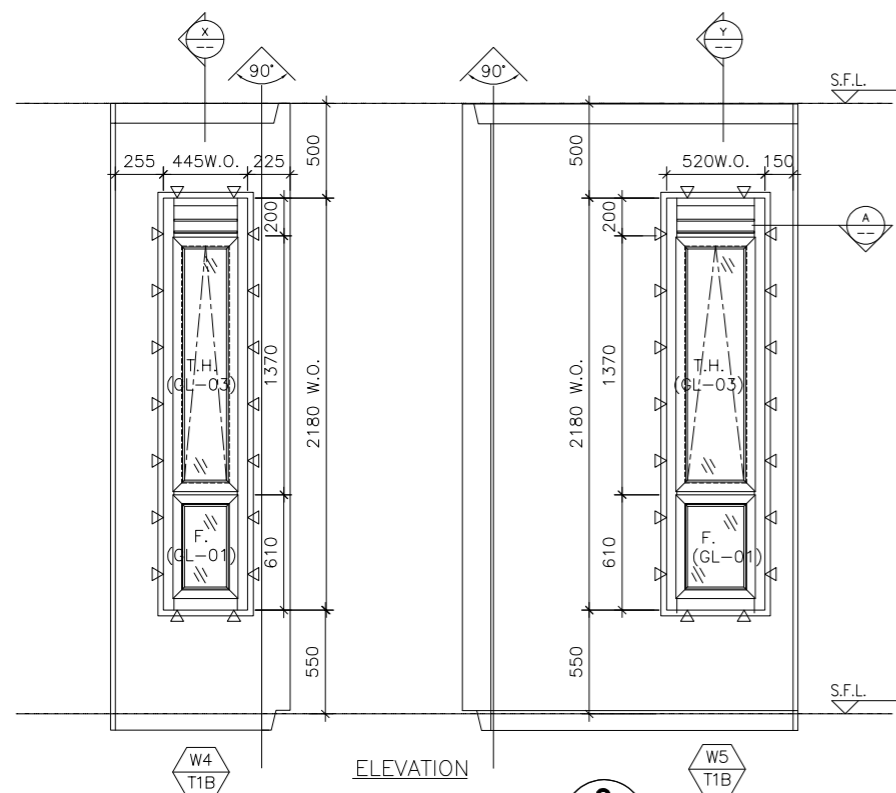

ELEVATION

WINDOW MARK
 W5 / W4
 T1B / T1B

LOCATION 2/F~21/F M.B. & EN.B. AT TOWER 1 FLAT B

SECTION 70mm ALUM. SECTION

GLAZING GL-01, GL-03

QUANTITY 17 / 17

REMARKS FACADE (PF-37)

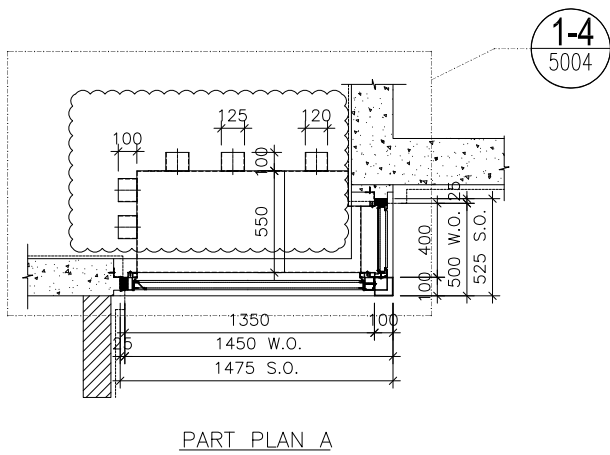
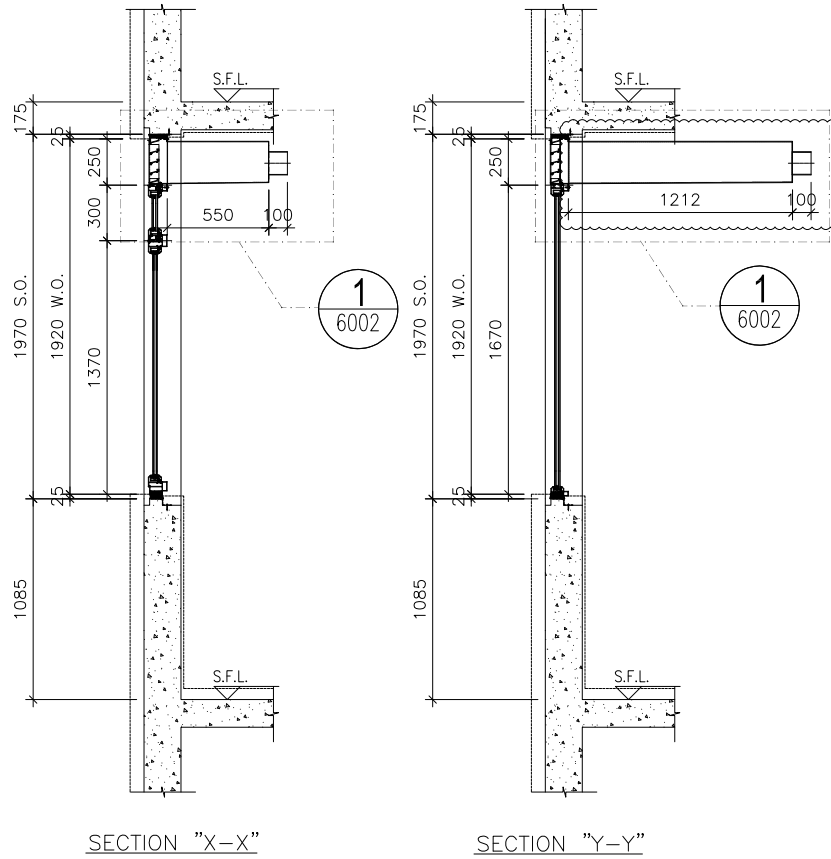
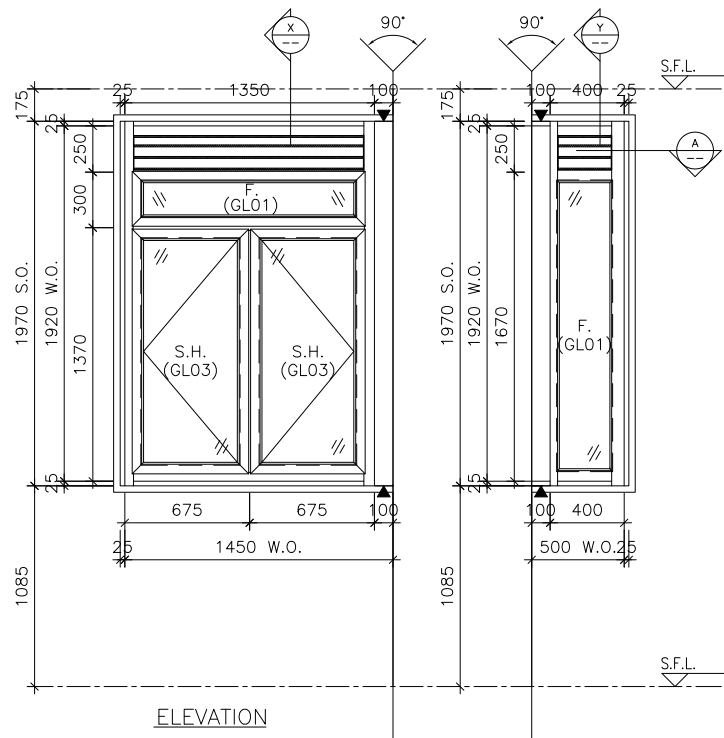

ELEVATION

ELEVATION

SECTION "X-X"

SECTION "Y-Y"

PART PLAN A

WINDOW MARK



LOCATION 1/F~21/F KIT. AT TOWER 1 FLAT B

SECTION 50mm ALUM. SECTION

GLAZING GL01, GL03

QUANTITY 18

REMARKS

B.D. REF :

CLIENT :

ARCHITECT :
AGC DESIGN LTD
 101, 102, 103, 104, 105, 106, 107, 108, 109, 110, 111, 112, 113, 114, 115, 116, 117, 118, 119, 120, 121, 122, 123, 124, 125, 126, 127, 128, 129, 130, 131, 132, 133, 134, 135, 136, 137, 138, 139, 140, 141, 142, 143, 144, 145, 146, 147, 148, 149, 150, 151, 152, 153, 154, 155, 156, 157, 158, 159, 160, 161, 162, 163, 164, 165, 166, 167, 168, 169, 170, 171, 172, 173, 174, 175, 176, 177, 178, 179, 180, 181, 182, 183, 184, 185, 186, 187, 188, 189, 190, 191, 192, 193, 194, 195, 196, 197, 198, 199, 200, 201, 202, 203, 204, 205, 206, 207, 208, 209, 210, 211, 212, 213, 214, 215, 216, 217, 218, 219, 220, 221, 222, 223, 224, 225, 226, 227, 228, 229, 230, 231, 232, 233, 234, 235, 236, 237, 238, 239, 240, 241, 242, 243, 244, 245, 246, 247, 248, 249, 250, 251, 252, 253, 254, 255, 256, 257, 258, 259, 260, 261, 262, 263, 264, 265, 266, 267, 268, 269, 270, 271, 272, 273, 274, 275, 276, 277, 278, 279, 280, 281, 282, 283, 284, 285, 286, 287, 288, 289, 290, 291, 292, 293, 294, 295, 296, 297, 298, 299, 300, 301, 302, 303, 304, 305, 306, 307, 308, 309, 310, 311, 312, 313, 314, 315, 316, 317, 318, 319, 320, 321, 322, 323, 324, 325, 326, 327, 328, 329, 330, 331, 332, 333, 334, 335, 336, 337, 338, 339, 340, 341, 342, 343, 344, 345, 346, 347, 348, 349, 350, 351, 352, 353, 354, 355, 356, 357, 358, 359, 360, 361, 362, 363, 364, 365, 366, 367, 368, 369, 370, 371, 372, 373, 374, 375, 376, 377, 378, 379, 380, 381, 382, 383, 384, 385, 386, 387, 388, 389, 390, 391, 392, 393, 394, 395, 396, 397, 398, 399, 400, 401, 402, 403, 404, 405, 406, 407, 408, 409, 410, 411, 412, 413, 414, 415, 416, 417, 418, 419, 420, 421, 422, 423, 424, 425, 426, 427, 428, 429, 430, 431, 432, 433, 434, 435, 436, 437, 438, 439, 440, 441, 442, 443, 444, 445, 446, 447, 448, 449, 450, 451, 452, 453, 454, 455, 456, 457, 458, 459, 460, 461, 462, 463, 464, 465, 466, 467, 468, 469, 470, 471, 472, 473, 474, 475, 476, 477, 478, 479, 480, 481, 482, 483, 484, 485, 486, 487, 488, 489, 490, 491, 492, 493, 494, 495, 496, 497, 498, 499, 500, 501, 502, 503, 504, 505, 506, 507, 508, 509, 510, 511, 512, 513, 514, 515, 516, 517, 518, 519, 520, 521, 522, 523, 524, 525, 526, 527, 528, 529, 530, 531, 532, 533, 534, 535, 536, 537, 538, 539, 540, 541, 542, 543, 544, 545, 546, 547, 548, 549, 550, 551, 552, 553, 554, 555, 556, 557, 558, 559, 560, 561, 562, 563, 564, 565, 566, 567, 568, 569, 570, 571, 572, 573, 574, 575, 576, 577, 578, 579, 580, 581, 582, 583, 584, 585, 586, 587, 588, 589, 590, 591, 592, 593, 594, 595, 596, 597, 598, 599, 600, 601, 602, 603, 604, 605, 606, 607, 608, 609, 610, 611, 612, 613, 614, 615, 616, 617, 618, 619, 620, 621, 622, 623, 624, 625, 626, 627, 628, 629, 630, 631, 632, 633, 634, 635, 636, 637, 638, 639, 640, 641, 642, 643, 644, 645, 646, 647, 648, 649, 650, 651, 652, 653, 654, 655, 656, 657, 658, 659, 660, 661, 662, 663, 664, 665, 666, 667, 668, 669, 670, 671, 672, 673, 674, 675, 676, 677, 678, 679, 680, 681, 682, 683, 684, 685, 686, 687, 688, 689, 690, 691, 692, 693, 694, 695, 696, 697, 698, 699, 700, 701, 702, 703, 704, 705, 706, 707, 708, 709, 710, 711, 712, 713, 714, 715, 716, 717, 718, 719, 720, 721, 722, 723, 724, 725, 726, 727, 728, 729, 730, 731, 732, 733, 734, 735, 736, 737, 738, 739, 740, 741, 742, 743, 744, 745, 746, 747, 748, 749, 750, 751, 752, 753, 754, 755, 756, 757, 758, 759, 760, 761, 762, 763, 764, 765, 766, 767, 768, 769, 770, 771, 772, 773, 774, 775, 776, 777, 778, 779, 780, 781, 782, 783, 784, 785, 786, 787, 788, 789, 790, 791, 792, 793, 794, 795, 796, 797, 798, 799, 800, 801, 802, 803, 804, 805, 806, 807, 808, 809, 810, 811, 812, 813, 814, 815, 816, 817, 818, 819, 820, 821, 822, 823, 824, 825, 826, 827, 828, 829, 830, 831, 832, 833, 834, 835, 836, 837, 838, 839, 840, 841, 842, 843, 844, 845, 846, 847, 848, 849, 850, 851, 852, 853, 854, 855, 856, 857, 858, 859, 860, 861, 862, 863, 864, 865, 866, 867, 868, 869, 870, 871, 872, 873, 874, 875, 876, 877, 878, 879, 880, 881, 882, 883, 884, 885, 886, 887, 888, 889, 890, 891, 892, 893, 894, 895, 896, 897, 898, 899, 900, 901, 902, 903, 904, 905, 906, 907, 908, 909, 910, 911, 912, 913, 914, 915, 916, 917, 918, 919, 920, 921, 922, 923, 924, 925, 926, 927, 928, 929, 930, 931, 932, 933, 934, 935, 936, 937, 938, 939, 940, 941, 942, 943, 944, 945, 946, 947, 948, 949, 950, 951, 952, 953, 954, 955, 956, 957, 958, 959, 960, 961, 962, 963, 964, 965, 966, 967, 968, 969, 970, 971, 972, 973, 974, 975, 976, 977, 978, 979, 980, 981, 982, 983, 984, 985, 986, 987, 988, 989, 990, 991, 992, 993, 994, 995, 996, 997, 998, 999, 1000

MAIN CONTRACTOR :
Gammon

STRUCTURAL ENGINEER :
ARUP

FACADE CONSULTANT:
MEINHARDT

NOTE :
 1. ALL DIMENSIONS ARE IN mm.
 2. ALL ELEVATIONS ARE VIEWED FROM OUTSIDE.
 3. ALL DIMENSIONS TO BE VERIFIED ON SITE BEFORE FABRICATION.

LEGEND :
 (X1) --- DETAIL MARK NO.
 (X001) --- REFER SHEET NO.
 1. F.F.L. --- FINISHED FLOOR LEVEL
 2. S.F.L. --- STRUCTURAL FLOOR LEVEL
 3. (R) --- REVERSED DETAIL
 4. ▲ --- FIXING LOCATION
 5. △ --- FIXING LUG LOCATION
 6. GLASS LEGEND
 GL01 --- 8mm+12mm AIR GAP+10mm THK. I.G.U.
 GL01a --- 8mm+9mm AIR GAP+12mm THK. I.G.U.
 GL03 --- 6mm+12mm AIR GAP+6mm THK. I.G.U.
 GL04 --- 10mm THK. TEMPERED GLASS (PROTECTIVE BARRIER)
 GL05 --- 6mm+12mm AIR GAP+8mm THK. I.G.U.

NO.	DATE	REVISION	BY
A	09/12/2020	REVISION SUBJECT TO ARCH.COMMENT	Ivan

JOB NO. : J-852
 PROJECT :
 PROPOSED RESIDENTIAL DEVELOPMENT
 AT 139 - 147 ARGYLE STREET,
 NKIL 6005, 6035 R.P., 6036 R.P.,
 6037 R.P. & 6038 R.P.

TITLE :
 SCHEDULE FOR Plenum Box
 At IN-SITU ALUM. WINDOW(T1:1-21F)

DATE : 05-FEB-20 SCALE : 1:100

DRAWN BY : MN CHECKED BY : DW

美特鋁質有限公司
MIDI ALUMINIUM FABRICATOR LTD.
 Units 6-8, Sunray Industrial Centre, 1/F
 610 Cha Kwo Ling Road, Kowloon
 Tel:23489211-4 Fax:(852)2727666

DWG NO. : J852-SD-PB-4105 REV. : A

ELEVATION

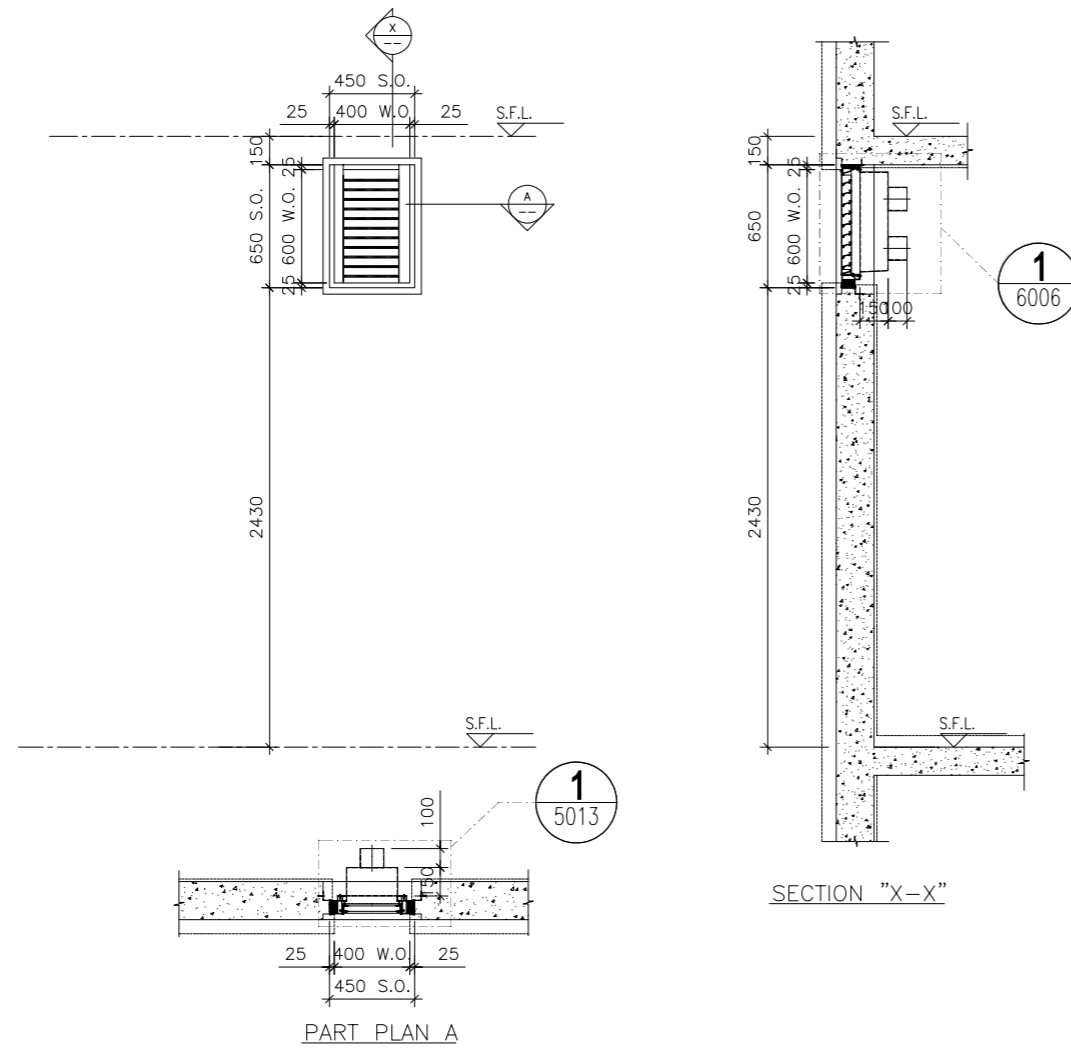

B.D. REF :

CLIENT :

ARCHITECT :
AGC DESIGN LTD
 100, 14/F, D'Almeida Place, 255, King's Road, North Point, Hong Kong
 Tel: (852) 27797816, Fax: (852) 27797133, Email: agc@agcdesign.com.hk

MAIN CONTRACTOR :
Gammon

STRUCTURAL ENGINEER :
ARUP

FACADE CONSULTANT:
MEINHARDT

NOTE :
 1. ALL DIMENSIONS ARE IN mm.
 2. ALL ELEVATIONS ARE VIEWED FROM OUTSIDE.
 3. ALL DIMENSIONS TO BE VERIFIED ON SITE BEFORE FABRICATION.

LEGEND :
 X1 --- DETAIL MARK NO.
 X001 --- REFER SHEET NO.
 1. F.F.L. --- FINISHED FLOOR LEVEL
 2. S.F.L. --- STRUCTURAL FLOOR LEVEL
 3. (R) --- REVERSED DETAIL
 4. ▲ --- FIXING LOCATION
 5. △ --- FIXING LUG LOCATION
 6. GLASS LEGEND
 GL01 --- 8mm+12mm AIR GAP+10mm THK. I.G.U.
 GL01a --- 8mm+9mm AIR GAP+12mm THK. I.G.U.
 GL03 --- 6mm+12mm AIR GAP+6mm THK. I.G.U.
 GL04 --- 10mm THK. TEMPERED GLASS (PROTECTIVE BARRIER)
 GL05 --- 6mm+12mm AIR GAP+8mm THK. I.G.U.

NO.	DATE	REVISED	BY
-----	------	---------	----

JOB NO. : J-852
 PROJECT : PROPOSED RESIDENTIAL DEVELOPMENT AT 139 - 147 ARGYLE STREET, NKIL 6005, 6035 R.P., 6036 R.P., 6037 R.P. & 6038 R.P.

TITLE : SCHEDULE FOR Plenum Box AT TOWER 1 (1-21F)

DATE : 05-Dec-19 SCALE : 1:40
 DRAWN BY : MN CHECKED BY : DW

美特鋁質有限公司
MIDI ALUMINIUM FABRICATOR LTD.
 Units 6-8, Sunray Industrial Centre, 1/F
 610 Cha Kwo Ling Road, Kowloon
 Tel: 23489211-4 Fax: (852) 27727666

WINDOW MARK	W9 T1C
LOCATION	1/F-21/F Corridor AT TOWER 1 FLAT C
SECTION	70mm ALUM. SECTION
GLAZING	
QUANTITY	18
REMARKS	

DWG NO. : J852-SD-PB-4106 REV. : -

ELEVATION

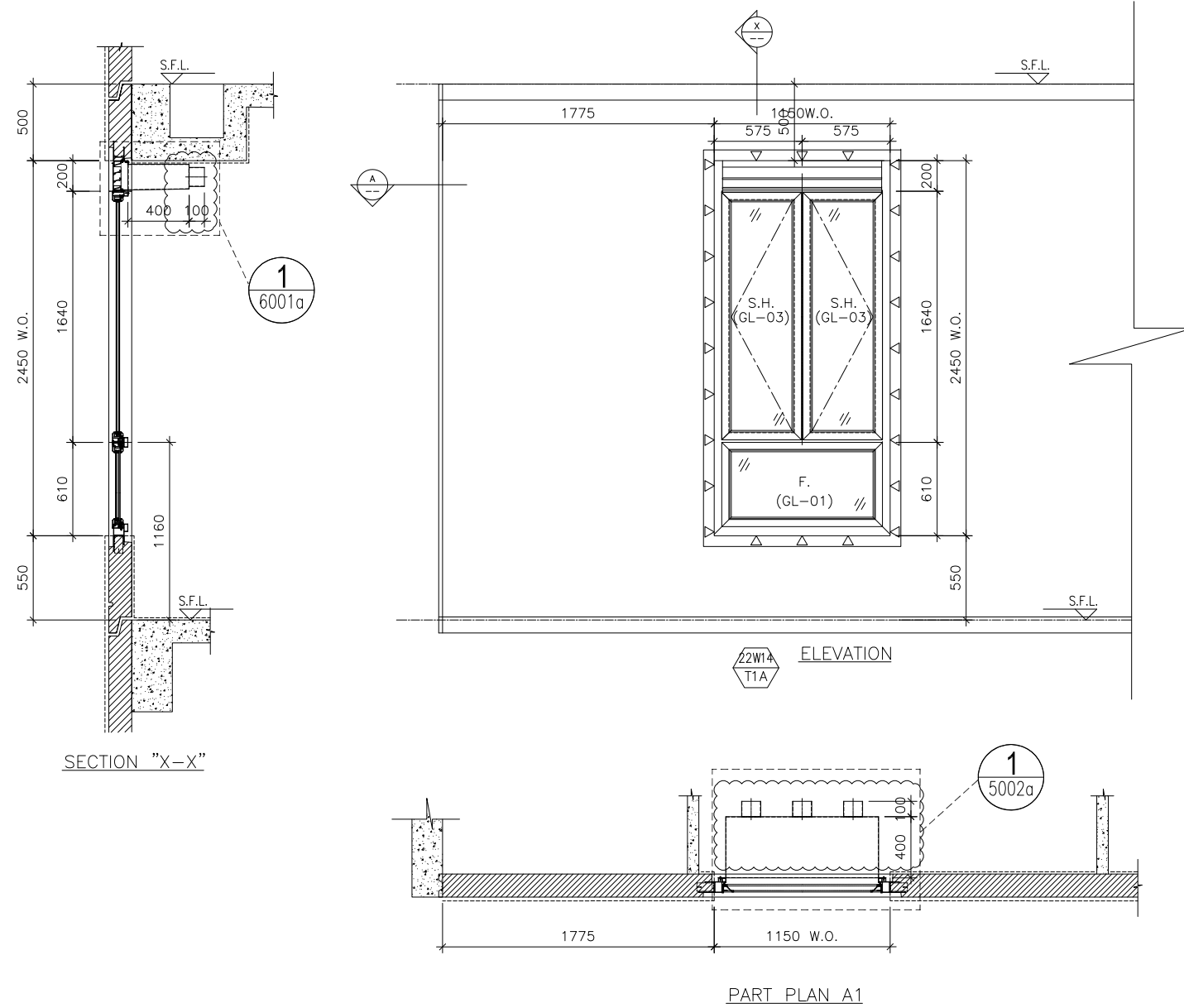

WINDOW MARK	22W14 T1A
LOCATION	22/F M.BATH & EN.B 3 AT TOWER 1 FLAT A
SECTION	70mm ALUM. SECTION
GLAZING	GL-01, GL-03
QUANTITY	1
REMARKS	FACADE (PF-22)

B.D. REF :

CLIENT :

ARCHITECT :
AGC DESIGN LTD
 101, 102, 103, 104, 105, 106, 107, 108, 109, 110, 111, 112, 113, 114, 115, 116, 117, 118, 119, 120, 121, 122, 123, 124, 125, 126, 127, 128, 129, 130, 131, 132, 133, 134, 135, 136, 137, 138, 139, 140, 141, 142, 143, 144, 145, 146, 147, 148, 149, 150, 151, 152, 153, 154, 155, 156, 157, 158, 159, 160, 161, 162, 163, 164, 165, 166, 167, 168, 169, 170, 171, 172, 173, 174, 175, 176, 177, 178, 179, 180, 181, 182, 183, 184, 185, 186, 187, 188, 189, 190, 191, 192, 193, 194, 195, 196, 197, 198, 199, 200, 201, 202, 203, 204, 205, 206, 207, 208, 209, 210, 211, 212, 213, 214, 215, 216, 217, 218, 219, 220, 221, 222, 223, 224, 225, 226, 227, 228, 229, 230, 231, 232, 233, 234, 235, 236, 237, 238, 239, 240, 241, 242, 243, 244, 245, 246, 247, 248, 249, 250, 251, 252, 253, 254, 255, 256, 257, 258, 259, 260, 261, 262, 263, 264, 265, 266, 267, 268, 269, 270, 271, 272, 273, 274, 275, 276, 277, 278, 279, 280, 281, 282, 283, 284, 285, 286, 287, 288, 289, 290, 291, 292, 293, 294, 295, 296, 297, 298, 299, 300, 301, 302, 303, 304, 305, 306, 307, 308, 309, 310, 311, 312, 313, 314, 315, 316, 317, 318, 319, 320, 321, 322, 323, 324, 325, 326, 327, 328, 329, 330, 331, 332, 333, 334, 335, 336, 337, 338, 339, 340, 341, 342, 343, 344, 345, 346, 347, 348, 349, 350, 351, 352, 353, 354, 355, 356, 357, 358, 359, 360, 361, 362, 363, 364, 365, 366, 367, 368, 369, 370, 371, 372, 373, 374, 375, 376, 377, 378, 379, 380, 381, 382, 383, 384, 385, 386, 387, 388, 389, 390, 391, 392, 393, 394, 395, 396, 397, 398, 399, 400, 401, 402, 403, 404, 405, 406, 407, 408, 409, 410, 411, 412, 413, 414, 415, 416, 417, 418, 419, 420, 421, 422, 423, 424, 425, 426, 427, 428, 429, 430, 431, 432, 433, 434, 435, 436, 437, 438, 439, 440, 441, 442, 443, 444, 445, 446, 447, 448, 449, 450, 451, 452, 453, 454, 455, 456, 457, 458, 459, 460, 461, 462, 463, 464, 465, 466, 467, 468, 469, 470, 471, 472, 473, 474, 475, 476, 477, 478, 479, 480, 481, 482, 483, 484, 485, 486, 487, 488, 489, 490, 491, 492, 493, 494, 495, 496, 497, 498, 499, 500, 501, 502, 503, 504, 505, 506, 507, 508, 509, 510, 511, 512, 513, 514, 515, 516, 517, 518, 519, 520, 521, 522, 523, 524, 525, 526, 527, 528, 529, 530, 531, 532, 533, 534, 535, 536, 537, 538, 539, 540, 541, 542, 543, 544, 545, 546, 547, 548, 549, 550, 551, 552, 553, 554, 555, 556, 557, 558, 559, 560, 561, 562, 563, 564, 565, 566, 567, 568, 569, 570, 571, 572, 573, 574, 575, 576, 577, 578, 579, 580, 581, 582, 583, 584, 585, 586, 587, 588, 589, 590, 591, 592, 593, 594, 595, 596, 597, 598, 599, 600, 601, 602, 603, 604, 605, 606, 607, 608, 609, 610, 611, 612, 613, 614, 615, 616, 617, 618, 619, 620, 621, 622, 623, 624, 625, 626, 627, 628, 629, 630, 631, 632, 633, 634, 635, 636, 637, 638, 639, 640, 641, 642, 643, 644, 645, 646, 647, 648, 649, 650, 651, 652, 653, 654, 655, 656, 657, 658, 659, 660, 661, 662, 663, 664, 665, 666, 667, 668, 669, 670, 671, 672, 673, 674, 675, 676, 677, 678, 679, 680, 681, 682, 683, 684, 685, 686, 687, 688, 689, 690, 691, 692, 693, 694, 695, 696, 697, 698, 699, 700, 701, 702, 703, 704, 705, 706, 707, 708, 709, 710, 711, 712, 713, 714, 715, 716, 717, 718, 719, 720, 721, 722, 723, 724, 725, 726, 727, 728, 729, 730, 731, 732, 733, 734, 735, 736, 737, 738, 739, 740, 741, 742, 743, 744, 745, 746, 747, 748, 749, 750, 751, 752, 753, 754, 755, 756, 757, 758, 759, 760, 761, 762, 763, 764, 765, 766, 767, 768, 769, 770, 771, 772, 773, 774, 775, 776, 777, 778, 779, 780, 781, 782, 783, 784, 785, 786, 787, 788, 789, 790, 791, 792, 793, 794, 795, 796, 797, 798, 799, 800, 801, 802, 803, 804, 805, 806, 807, 808, 809, 810, 811, 812, 813, 814, 815, 816, 817, 818, 819, 820, 821, 822, 823, 824, 825, 826, 827, 828, 829, 830, 831, 832, 833, 834, 835, 836, 837, 838, 839, 840, 841, 842, 843, 844, 845, 846, 847, 848, 849, 850, 851, 852, 853, 854, 855, 856, 857, 858, 859, 860, 861, 862, 863, 864, 865, 866, 867, 868, 869, 870, 871, 872, 873, 874, 875, 876, 877, 878, 879, 880, 881, 882, 883, 884, 885, 886, 887, 888, 889, 890, 891, 892, 893, 894, 895, 896, 897, 898, 899, 900, 901, 902, 903, 904, 905, 906, 907, 908, 909, 910, 911, 912, 913, 914, 915, 916, 917, 918, 919, 920, 921, 922, 923, 924, 925, 926, 927, 928, 929, 930, 931, 932, 933, 934, 935, 936, 937, 938, 939, 940, 941, 942, 943, 944, 945, 946, 947, 948, 949, 950, 951, 952, 953, 954, 955, 956, 957, 958, 959, 960, 961, 962, 963, 964, 965, 966, 967, 968, 969, 970, 971, 972, 973, 974, 975, 976, 977, 978, 979, 980, 981, 982, 983, 984, 985, 986, 987, 988, 989, 990, 991, 992, 993, 994, 995, 996, 997, 998, 999, 1000

MAIN CONTRACTOR :
Gammon

STRUCTURAL ENGINEER :
ARUP

FACADE CONSULTANT:
MEINHARDT

NOTE :
 1. ALL DIMENSIONS ARE IN mm.
 2. ALL ELEVATIONS ARE VIEWED FROM OUTSIDE.
 3. ALL DIMENSIONS TO BE VERIFIED ON SITE BEFORE FABRICATION.

LEGEND :
 (X1) --- DETAIL MARK NO.
 (X001) --- REFER SHEET NO.
 1. F.F.L. --- FINISHED FLOOR LEVEL
 2. S.F.L. --- STRUCTURAL FLOOR LEVEL
 3. (R) --- REVERSED DETAIL
 4. ▲ --- FIXING LOCATION
 5. △ --- FIXING LUG LOCATION
 6. GLASS LEGEND
 GL01 --- 8mm+12mm AIR GAP+10mm THK. I.G.U.
 GL01a --- 8mm+9mm AIR GAP+12mm THK. I.G.U.
 GL03 --- 6mm+12mm AIR GAP+6mm THK. I.G.U.
 GL04 --- 10mm THK. TEMPERED GLASS (PROTECTIVE BARRIER)
 GL05 --- 6mm+12mm AIR GAP+8mm THK. I.G.U.

A	09/12/2020	REVISION SUBJECT TO ARCH.COMMENT	lv
NO.	DATE	REVISION	BY

JOB NO. : J-852
 PROJECT :
 PROPOSED RESIDENTIAL DEVELOPMENT
 AT 139 - 147 ARGYLE STREET,
 NKIL 6005, 6035 R.P., 6036 R.P.,
 6037 R.P. & 6038 R.P.

TITLE :
 SCHEDULE FOR Plenum Box
 AT TOWER 1

DATE : 05-Dec-19 SCALE : 1:40
 DRAWN BY : MN CHECKED BY : DW

美特鋁質有限公司
MIDI ALUMINIUM FABRICATOR LTD.
 Units 6-8, Sunray Industrial Centre, 1/F
 610 Cha Kwo Ling Road, Kowloon
 Tel:23489211-4 Fax:(852)2727666

DWG NO. : J852-SD-PB-4107 REV. : A

ELEVATION

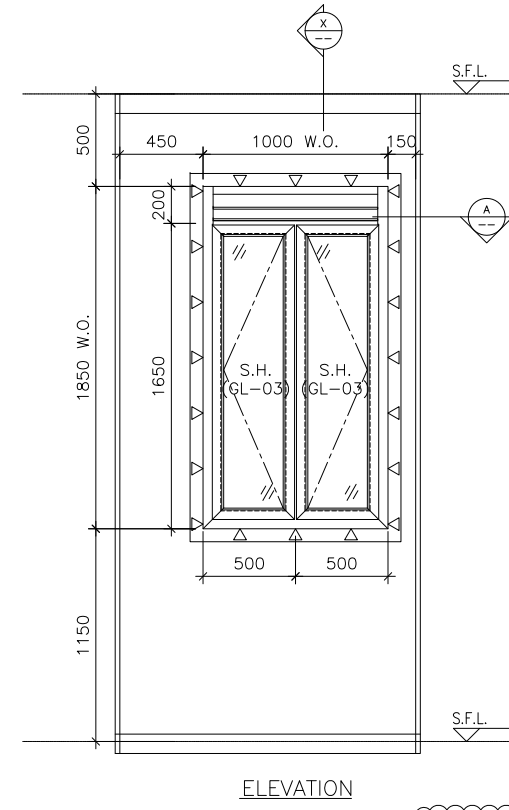

ELEVATION

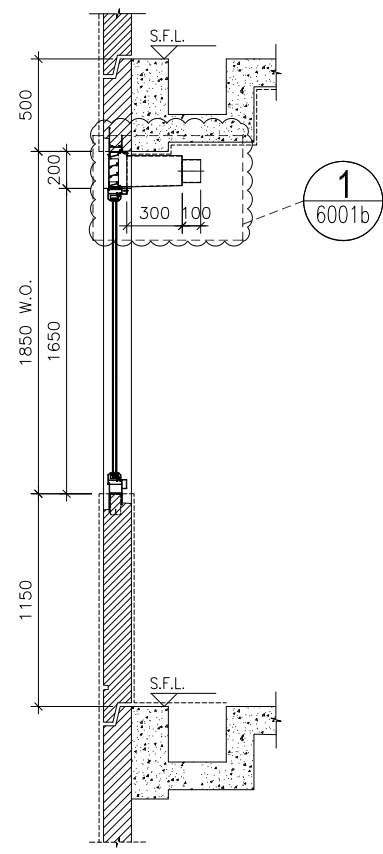

SECTION "X-X"

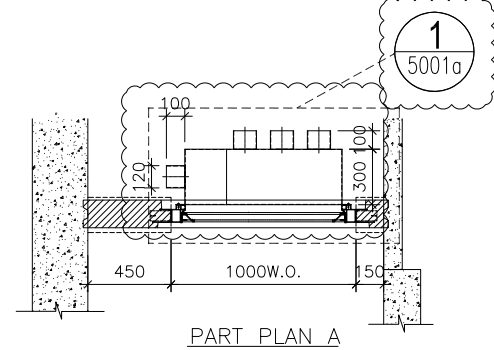

PART PLAN A

WINDOW MARK



LOCATION 22/F KIT. AT TOWER 1 FLAT C

SECTION 70mm ALUM. SECTION

GLAZING GL-03

QUANTITY 1

REMARKS FACADE (PF-31)

B.D. REF :

CLIENT :

ARCHITECT :
AGC DESIGN LTD
 101, 102, 103, 104, 105, 106, 107, 108, 109, 110, 111, 112, 113, 114, 115, 116, 117, 118, 119, 120, 121, 122, 123, 124, 125, 126, 127, 128, 129, 130, 131, 132, 133, 134, 135, 136, 137, 138, 139, 140, 141, 142, 143, 144, 145, 146, 147, 148, 149, 150, 151, 152, 153, 154, 155, 156, 157, 158, 159, 160, 161, 162, 163, 164, 165, 166, 167, 168, 169, 170, 171, 172, 173, 174, 175, 176, 177, 178, 179, 180, 181, 182, 183, 184, 185, 186, 187, 188, 189, 190, 191, 192, 193, 194, 195, 196, 197, 198, 199, 200, 201, 202, 203, 204, 205, 206, 207, 208, 209, 210, 211, 212, 213, 214, 215, 216, 217, 218, 219, 220, 221, 222, 223, 224, 225, 226, 227, 228, 229, 230, 231, 232, 233, 234, 235, 236, 237, 238, 239, 240, 241, 242, 243, 244, 245, 246, 247, 248, 249, 250, 251, 252, 253, 254, 255, 256, 257, 258, 259, 260, 261, 262, 263, 264, 265, 266, 267, 268, 269, 270, 271, 272, 273, 274, 275, 276, 277, 278, 279, 280, 281, 282, 283, 284, 285, 286, 287, 288, 289, 290, 291, 292, 293, 294, 295, 296, 297, 298, 299, 300, 301, 302, 303, 304, 305, 306, 307, 308, 309, 310, 311, 312, 313, 314, 315, 316, 317, 318, 319, 320, 321, 322, 323, 324, 325, 326, 327, 328, 329, 330, 331, 332, 333, 334, 335, 336, 337, 338, 339, 340, 341, 342, 343, 344, 345, 346, 347, 348, 349, 350, 351, 352, 353, 354, 355, 356, 357, 358, 359, 360, 361, 362, 363, 364, 365, 366, 367, 368, 369, 370, 371, 372, 373, 374, 375, 376, 377, 378, 379, 380, 381, 382, 383, 384, 385, 386, 387, 388, 389, 390, 391, 392, 393, 394, 395, 396, 397, 398, 399, 400, 401, 402, 403, 404, 405, 406, 407, 408, 409, 410, 411, 412, 413, 414, 415, 416, 417, 418, 419, 420, 421, 422, 423, 424, 425, 426, 427, 428, 429, 430, 431, 432, 433, 434, 435, 436, 437, 438, 439, 440, 441, 442, 443, 444, 445, 446, 447, 448, 449, 450, 451, 452, 453, 454, 455, 456, 457, 458, 459, 460, 461, 462, 463, 464, 465, 466, 467, 468, 469, 470, 471, 472, 473, 474, 475, 476, 477, 478, 479, 480, 481, 482, 483, 484, 485, 486, 487, 488, 489, 490, 491, 492, 493, 494, 495, 496, 497, 498, 499, 500, 501, 502, 503, 504, 505, 506, 507, 508, 509, 510, 511, 512, 513, 514, 515, 516, 517, 518, 519, 520, 521, 522, 523, 524, 525, 526, 527, 528, 529, 530, 531, 532, 533, 534, 535, 536, 537, 538, 539, 540, 541, 542, 543, 544, 545, 546, 547, 548, 549, 550, 551, 552, 553, 554, 555, 556, 557, 558, 559, 560, 561, 562, 563, 564, 565, 566, 567, 568, 569, 570, 571, 572, 573, 574, 575, 576, 577, 578, 579, 580, 581, 582, 583, 584, 585, 586, 587, 588, 589, 590, 591, 592, 593, 594, 595, 596, 597, 598, 599, 600, 601, 602, 603, 604, 605, 606, 607, 608, 609, 610, 611, 612, 613, 614, 615, 616, 617, 618, 619, 620, 621, 622, 623, 624, 625, 626, 627, 628, 629, 630, 631, 632, 633, 634, 635, 636, 637, 638, 639, 640, 641, 642, 643, 644, 645, 646, 647, 648, 649, 650, 651, 652, 653, 654, 655, 656, 657, 658, 659, 660, 661, 662, 663, 664, 665, 666, 667, 668, 669, 670, 671, 672, 673, 674, 675, 676, 677, 678, 679, 680, 681, 682, 683, 684, 685, 686, 687, 688, 689, 690, 691, 692, 693, 694, 695, 696, 697, 698, 699, 700, 701, 702, 703, 704, 705, 706, 707, 708, 709, 710, 711, 712, 713, 714, 715, 716, 717, 718, 719, 720, 721, 722, 723, 724, 725, 726, 727, 728, 729, 730, 731, 732, 733, 734, 735, 736, 737, 738, 739, 740, 741, 742, 743, 744, 745, 746, 747, 748, 749, 750, 751, 752, 753, 754, 755, 756, 757, 758, 759, 760, 761, 762, 763, 764, 765, 766, 767, 768, 769, 770, 771, 772, 773, 774, 775, 776, 777, 778, 779, 780, 781, 782, 783, 784, 785, 786, 787, 788, 789, 790, 791, 792, 793, 794, 795, 796, 797, 798, 799, 800, 801, 802, 803, 804, 805, 806, 807, 808, 809, 810, 811, 812, 813, 814, 815, 816, 817, 818, 819, 820, 821, 822, 823, 824, 825, 826, 827, 828, 829, 830, 831, 832, 833, 834, 835, 836, 837, 838, 839, 840, 841, 842, 843, 844, 845, 846, 847, 848, 849, 850, 851, 852, 853, 854, 855, 856, 857, 858, 859, 860, 861, 862, 863, 864, 865, 866, 867, 868, 869, 870, 871, 872, 873, 874, 875, 876, 877, 878, 879, 880, 881, 882, 883, 884, 885, 886, 887, 888, 889, 890, 891, 892, 893, 894, 895, 896, 897, 898, 899, 900, 901, 902, 903, 904, 905, 906, 907, 908, 909, 910, 911, 912, 913, 914, 915, 916, 917, 918, 919, 920, 921, 922, 923, 924, 925, 926, 927, 928, 929, 930, 931, 932, 933, 934, 935, 936, 937, 938, 939, 940, 941, 942, 943, 944, 945, 946, 947, 948, 949, 950, 951, 952, 953, 954, 955, 956, 957, 958, 959, 960, 961, 962, 963, 964, 965, 966, 967, 968, 969, 970, 971, 972, 973, 974, 975, 976, 977, 978, 979, 980, 981, 982, 983, 984, 985, 986, 987, 988, 989, 990, 991, 992, 993, 994, 995, 996, 997, 998, 999, 1000

MAIN CONTRACTOR :
Gammon

STRUCTURAL ENGINEER :
ARUP

FACADE CONSULTANT:
MEINHARDT

NOTE :
 1. ALL DIMENSIONS ARE IN mm.
 2. ALL ELEVATIONS ARE VIEWED FROM OUTSIDE.
 3. ALL DIMENSIONS TO BE VERIFIED ON SITE BEFORE FABRICATION.

LEGEND :
 (X1) --- DETAIL MARK NO.
 (X001) --- REFER SHEET NO.
 1. F.F.L. --- FINISHED FLOOR LEVEL
 2. S.F.L. --- STRUCTURAL FLOOR LEVEL
 3. (R) --- REVERSED DETAIL
 4. ▲ --- FIXING LOCATION
 5. △ --- FIXING LUG LOCATION
 6. GLASS LEGEND
 GL01 --- 8mm+12mm AIR GAP+10mm THK. I.G.U.
 GL01a --- 8mm+9mm AIR GAP+12mm THK. I.G.U.
 GL03 --- 6mm+12mm AIR GAP+6mm THK. I.G.U.
 GL04 --- 10mm THK. TEMPERED GLASS (PROTECTIVE BARRIER)
 GL05 --- 6mm+12mm AIR GAP+8mm THK. I.G.U.

A	09/12/2020	REVISION SUBJECT TO ARCH.COMMENT	lvart
NO.	DATE	REVISION	BY

JOB NO. : J-852
 PROJECT :
 PROPOSED RESIDENTIAL DEVELOPMENT
 AT 139 - 147 ARGYLE STREET,
 NKIL 6005, 6035 R.P., 6036 R.P.,
 6037 R.P. & 6038 R.P.

TITLE :
 SCHEDULE FOR Plenum Box
 AT TOWER 1

DATE : 05-Dec-19 SCALE : 1:40

DRAWN BY : MN CHECKED BY : DW

美特鋁質有限公司
MIDI ALUMINIUM FABRICATOR LTD.
 Units 6-8, Sunray Industrial Centre, 1/F
 610 Cha Kwo Ling Road, Kowloon
 Tel:23489211-4 Fax:(852)2727666

DWG NO. : J852-SD-PB-4108 REV. : A

ELEVATION

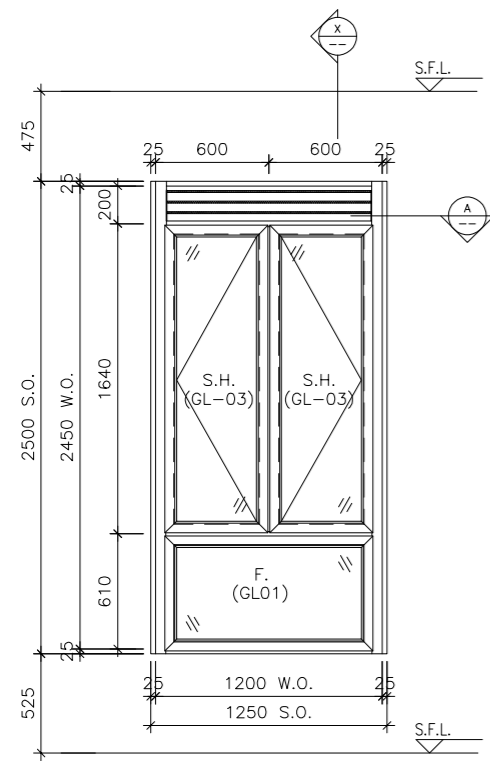

ELEVATION

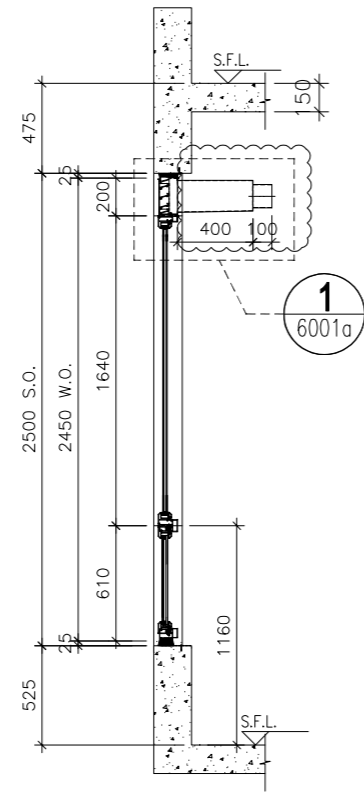

SECTION "X-X"

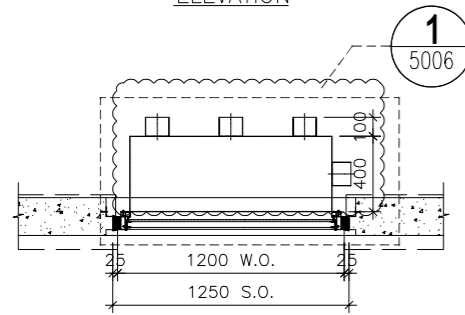

PART PLAN A

WINDOW MARK



LOCATION 22/F BATH AT TOWER 1 FLAT A

SECTION 70mm ALUM. SECTION

GLAZING GL-01, GL-03

QUANTITY 1

REMARKS

B.D. REF :

CLIENT :

ARCHITECT :
AGC DESIGN LTD
 1001, 14/F, Ocean Plaza, 225, King's Road, North Point, Hong Kong
 Tel: (852)27797812, Fax: (852)27797133, Email: agc@agc.com.hk

MAIN CONTRACTOR :
Gammon

STRUCTURAL ENGINEER :
ARUP

FACADE CONSULTANT:
MEINHARDT

NOTE :
 1. ALL DIMENSIONS ARE IN mm.
 2. ALL ELEVATIONS ARE VIEWED FROM OUTSIDE.
 3. ALL DIMENSIONS TO BE VERIFIED ON SITE BEFORE FABRICATION.

LEGEND :
 X1 --- DETAIL MARK NO.
 X001 --- REFER SHEET NO.
 1. F.F.L. --- FINISHED FLOOR LEVEL
 2. S.F.L. --- STRUCTURAL FLOOR LEVEL
 3. (R) --- REVERSED DETAIL

NO.	DATE	REVISION	REVISOR	BY
A	07/11/2020	REVISION SUBJECT TO ARCH.COMMENT		Ivan

JOB NO. : J-852
 PROJECT : PROPOSED RESIDENTIAL DEVELOPMENT AT 139 - 147 ARGYLE STREET, NKIL 6005, 6035 R.P., 6036 R.P., 6037 R.P. & 6038 R.P.

TITLE : SCHEDULE FOR Plenum Box At IN-SITU ALUM. WINDOW(T1-22F)

DATE : 05-FEB-20 SCALE : 1:100
 DRAWN BY : MN CHECKED BY : DW

美特鋁質有限公司
MIDI ALUMINIUM FABRICATOR LTD.
 Units 6-8, Sunray Industrial Centre, 1/F
 610 Cha Kwo Ling Road, Kowloon
 Tel:23489211-4 Fax:(852)27727666

DWG NO. : J852-SD-PB-4109 REV. : A

ELEVATION

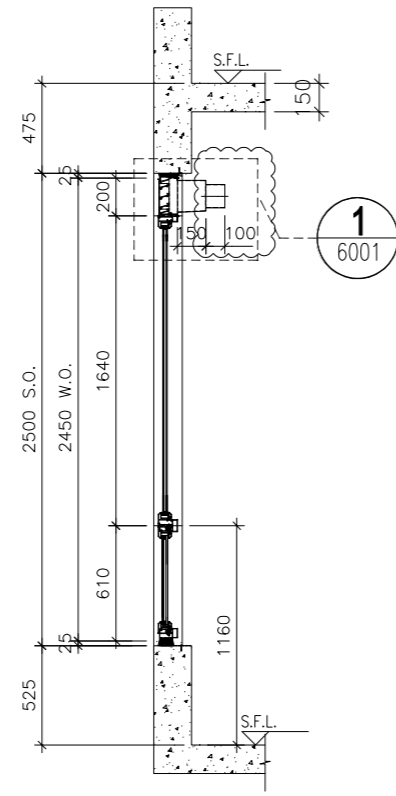
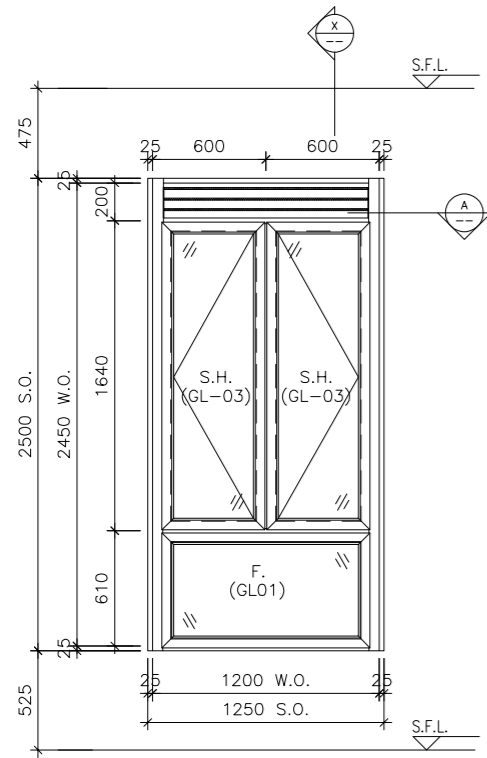

SECTION "X-X"

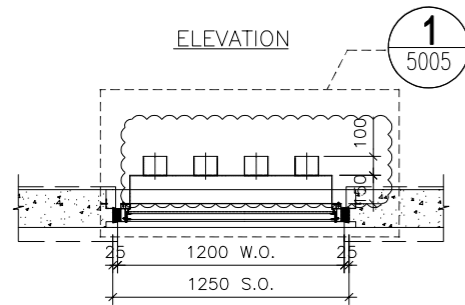

PART PLAN A

WINDOW MARK



LOCATION 22/F EN. B 3 AT TOWER 1 FLAT A

SECTION 70mm ALUM. SECTION

GLAZING GL-01, GL-03

QUANTITY 1

REMARKS

B.D. REF :

CLIENT :

ARCHITECT :
AGC DESIGN LTD
 1001, 14/F, Ocean Plaza, 225, King's Road, North Point, Hong Kong
 Tel: (852)27797812, Fax: (852)27797133, Email: agc@agc.com.hk

MAIN CONTRACTOR :
Gammon

STRUCTURAL ENGINEER :
ARUP

FACADE CONSULTANT:
MEINHARDT

NOTE :
 1. ALL DIMENSIONS ARE IN mm.
 2. ALL ELEVATIONS ARE VIEWED FROM OUTSIDE.
 3. ALL DIMENSIONS TO BE VERIFIED ON SITE BEFORE FABRICATION.

LEGEND :
 X1 --- DETAIL MARK NO.
 X001 --- REFER SHEET NO.

1. F.F.L. --- FINISHED FLOOR LEVEL
 2. S.F.L. --- STRUCTURAL FLOOR LEVEL
 3. (R) --- REVERSED DETAIL

NO.	DATE	REVISION	REVISOR	BY
A	07/11/2020	REVISION SUBJECT TO ARCH.COMMENT		Ivan

JOB NO. : J-852

PROJECT :
 PROPOSED RESIDENTIAL DEVELOPMENT
 AT 139 - 147 ARGYLE STREET,
 NKIL 6005, 6035 R.P., 6036 R.P.,
 6037 R.P. & 6038 R.P.

TITLE :
 SCHEDULE FOR Plenum Box
 At IN-SITU ALUM. WINDOW(T1-22F)

DATE : 05-FEB-20 SCALE : 1:100

DRAWN BY : MN CHECKED BY : DW

美特鋁質有限公司
MIDI ALUMINIUM FABRICATOR LTD.
 Units 6-8, Sunray Industrial Centre, 1/F
 610 Cha Kwo Ling Road, Kowloon
 Tel:23489211-4 Fax:(852)27727666

DWG NO. : J852-SD-PB-4110 REV. : A

ELEVATION

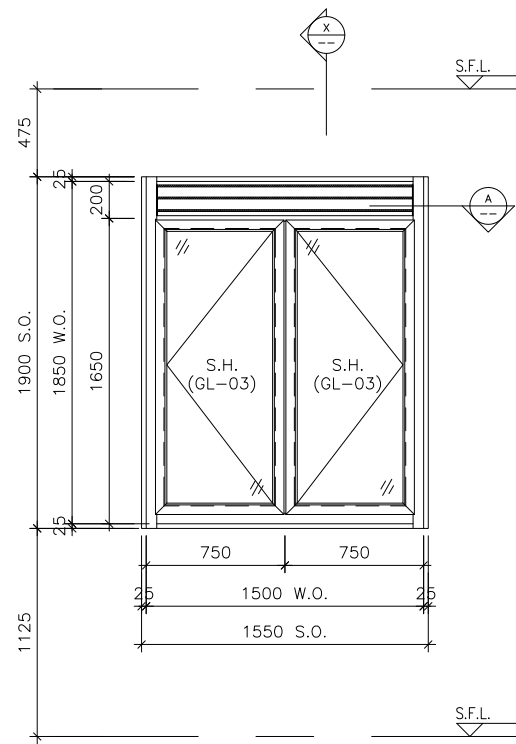

ELEVATION

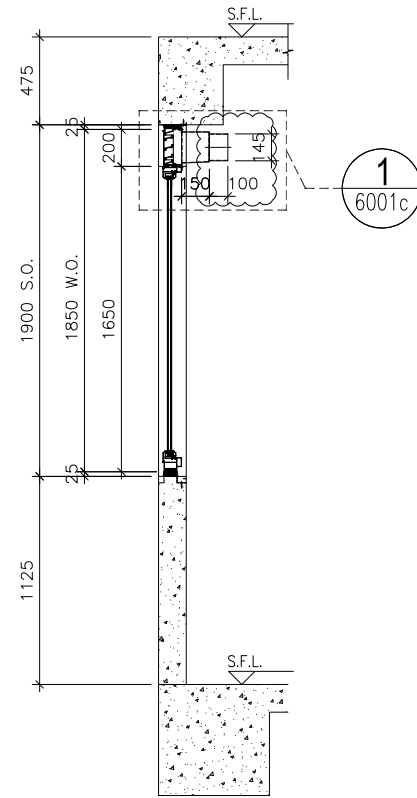

SECTION "X-X"

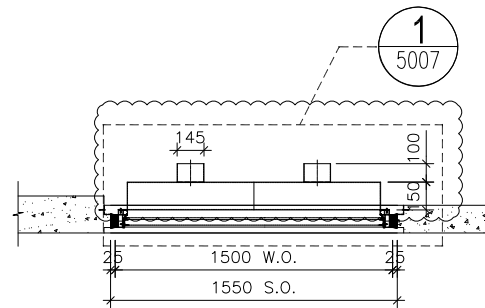

PART PLAN A

WINDOW MARK	
LOCATION	22/F KIT. AT TOWER 1 FLAT A
SECTION	70mm ALUM. SECTION
GLAZING	GL-03
QUANTITY	1
REMARKS	

B.D. REF :

CLIENT :

ARCHITECT :
AGC DESIGN LTD
 101, 102, 103, 104, 105, 106, 107, 108, 109, 110, 111, 112, 113, 114, 115, 116, 117, 118, 119, 120, 121, 122, 123, 124, 125, 126, 127, 128, 129, 130, 131, 132, 133, 134, 135, 136, 137, 138, 139, 140, 141, 142, 143, 144, 145, 146, 147, 148, 149, 150, 151, 152, 153, 154, 155, 156, 157, 158, 159, 160, 161, 162, 163, 164, 165, 166, 167, 168, 169, 170, 171, 172, 173, 174, 175, 176, 177, 178, 179, 180, 181, 182, 183, 184, 185, 186, 187, 188, 189, 190, 191, 192, 193, 194, 195, 196, 197, 198, 199, 200, 201, 202, 203, 204, 205, 206, 207, 208, 209, 210, 211, 212, 213, 214, 215, 216, 217, 218, 219, 220, 221, 222, 223, 224, 225, 226, 227, 228, 229, 230, 231, 232, 233, 234, 235, 236, 237, 238, 239, 240, 241, 242, 243, 244, 245, 246, 247, 248, 249, 250, 251, 252, 253, 254, 255, 256, 257, 258, 259, 260, 261, 262, 263, 264, 265, 266, 267, 268, 269, 270, 271, 272, 273, 274, 275, 276, 277, 278, 279, 280, 281, 282, 283, 284, 285, 286, 287, 288, 289, 290, 291, 292, 293, 294, 295, 296, 297, 298, 299, 300, 301, 302, 303, 304, 305, 306, 307, 308, 309, 310, 311, 312, 313, 314, 315, 316, 317, 318, 319, 320, 321, 322, 323, 324, 325, 326, 327, 328, 329, 330, 331, 332, 333, 334, 335, 336, 337, 338, 339, 340, 341, 342, 343, 344, 345, 346, 347, 348, 349, 350, 351, 352, 353, 354, 355, 356, 357, 358, 359, 360, 361, 362, 363, 364, 365, 366, 367, 368, 369, 370, 371, 372, 373, 374, 375, 376, 377, 378, 379, 380, 381, 382, 383, 384, 385, 386, 387, 388, 389, 390, 391, 392, 393, 394, 395, 396, 397, 398, 399, 400, 401, 402, 403, 404, 405, 406, 407, 408, 409, 410, 411, 412, 413, 414, 415, 416, 417, 418, 419, 420, 421, 422, 423, 424, 425, 426, 427, 428, 429, 430, 431, 432, 433, 434, 435, 436, 437, 438, 439, 440, 441, 442, 443, 444, 445, 446, 447, 448, 449, 450, 451, 452, 453, 454, 455, 456, 457, 458, 459, 460, 461, 462, 463, 464, 465, 466, 467, 468, 469, 470, 471, 472, 473, 474, 475, 476, 477, 478, 479, 480, 481, 482, 483, 484, 485, 486, 487, 488, 489, 490, 491, 492, 493, 494, 495, 496, 497, 498, 499, 500, 501, 502, 503, 504, 505, 506, 507, 508, 509, 510, 511, 512, 513, 514, 515, 516, 517, 518, 519, 520, 521, 522, 523, 524, 525, 526, 527, 528, 529, 530, 531, 532, 533, 534, 535, 536, 537, 538, 539, 540, 541, 542, 543, 544, 545, 546, 547, 548, 549, 550, 551, 552, 553, 554, 555, 556, 557, 558, 559, 560, 561, 562, 563, 564, 565, 566, 567, 568, 569, 570, 571, 572, 573, 574, 575, 576, 577, 578, 579, 580, 581, 582, 583, 584, 585, 586, 587, 588, 589, 590, 591, 592, 593, 594, 595, 596, 597, 598, 599, 600, 601, 602, 603, 604, 605, 606, 607, 608, 609, 610, 611, 612, 613, 614, 615, 616, 617, 618, 619, 620, 621, 622, 623, 624, 625, 626, 627, 628, 629, 630, 631, 632, 633, 634, 635, 636, 637, 638, 639, 640, 641, 642, 643, 644, 645, 646, 647, 648, 649, 650, 651, 652, 653, 654, 655, 656, 657, 658, 659, 660, 661, 662, 663, 664, 665, 666, 667, 668, 669, 670, 671, 672, 673, 674, 675, 676, 677, 678, 679, 680, 681, 682, 683, 684, 685, 686, 687, 688, 689, 690, 691, 692, 693, 694, 695, 696, 697, 698, 699, 700, 701, 702, 703, 704, 705, 706, 707, 708, 709, 710, 711, 712, 713, 714, 715, 716, 717, 718, 719, 720, 721, 722, 723, 724, 725, 726, 727, 728, 729, 730, 731, 732, 733, 734, 735, 736, 737, 738, 739, 740, 741, 742, 743, 744, 745, 746, 747, 748, 749, 750, 751, 752, 753, 754, 755, 756, 757, 758, 759, 760, 761, 762, 763, 764, 765, 766, 767, 768, 769, 770, 771, 772, 773, 774, 775, 776, 777, 778, 779, 780, 781, 782, 783, 784, 785, 786, 787, 788, 789, 790, 791, 792, 793, 794, 795, 796, 797, 798, 799, 800, 801, 802, 803, 804, 805, 806, 807, 808, 809, 810, 811, 812, 813, 814, 815, 816, 817, 818, 819, 820, 821, 822, 823, 824, 825, 826, 827, 828, 829, 830, 831, 832, 833, 834, 835, 836, 837, 838, 839, 840, 841, 842, 843, 844, 845, 846, 847, 848, 849, 850, 851, 852, 853, 854, 855, 856, 857, 858, 859, 860, 861, 862, 863, 864, 865, 866, 867, 868, 869, 870, 871, 872, 873, 874, 875, 876, 877, 878, 879, 880, 881, 882, 883, 884, 885, 886, 887, 888, 889, 890, 891, 892, 893, 894, 895, 896, 897, 898, 899, 900, 901, 902, 903, 904, 905, 906, 907, 908, 909, 910, 911, 912, 913, 914, 915, 916, 917, 918, 919, 920, 921, 922, 923, 924, 925, 926, 927, 928, 929, 930, 931, 932, 933, 934, 935, 936, 937, 938, 939, 940, 941, 942, 943, 944, 945, 946, 947, 948, 949, 950, 951, 952, 953, 954, 955, 956, 957, 958, 959, 960, 961, 962, 963, 964, 965, 966, 967, 968, 969, 970, 971, 972, 973, 974, 975, 976, 977, 978, 979, 980, 981, 982, 983, 984, 985, 986, 987, 988, 989, 990, 991, 992, 993, 994, 995, 996, 997, 998, 999, 1000

MAIN CONTRACTOR :

STRUCTURAL ENGINEER :

FACADE CONSULTANT:

NOTE :
 1. ALL DIMENSIONS ARE IN mm.
 2. ALL ELEVATIONS ARE VIEWED FROM OUTSIDE.
 3. ALL DIMENSIONS TO BE VERIFIED ON SITE BEFORE FABRICATION.

LEGEND :

 1. F.F.L. -- FINISHED FLOOR LEVEL
 2. S.F.L. -- STRUCTURAL FLOOR LEVEL
 3. (R) -- REVERSED DETAIL

NO.	DATE	REVISION	BY
A	09/12/2020	REVISION SUBJECT TO ARCH.COMMENT	Ivan

JOB NO. : J-852
 PROJECT : PROPOSED RESIDENTIAL DEVELOPMENT AT 139 - 147 ARGYLE STREET, NKIL 6005, 6035 R.P., 6036 R.P., 6037 R.P. & 6038 R.P.

TITLE : SCHEDULE FOR Plenum Box At IN-SITU ALUM. WINDOW(T1-22F)

DATE : 05-FEB-20 SCALE : 1:100
 DRAWN BY : MN CHECKED BY : DW

MIDI ALUMINIUM FABRICATOR LTD.
 Units 6-8, Sunray Industrial Centre, 1/F
 610 Cha Kwo Ling Road, Kowloon
 Tel:23489211-4 Fax:(852)2727666
 DWG NO. : J852-SD-PB-4111 REV. : A

ELEVATION

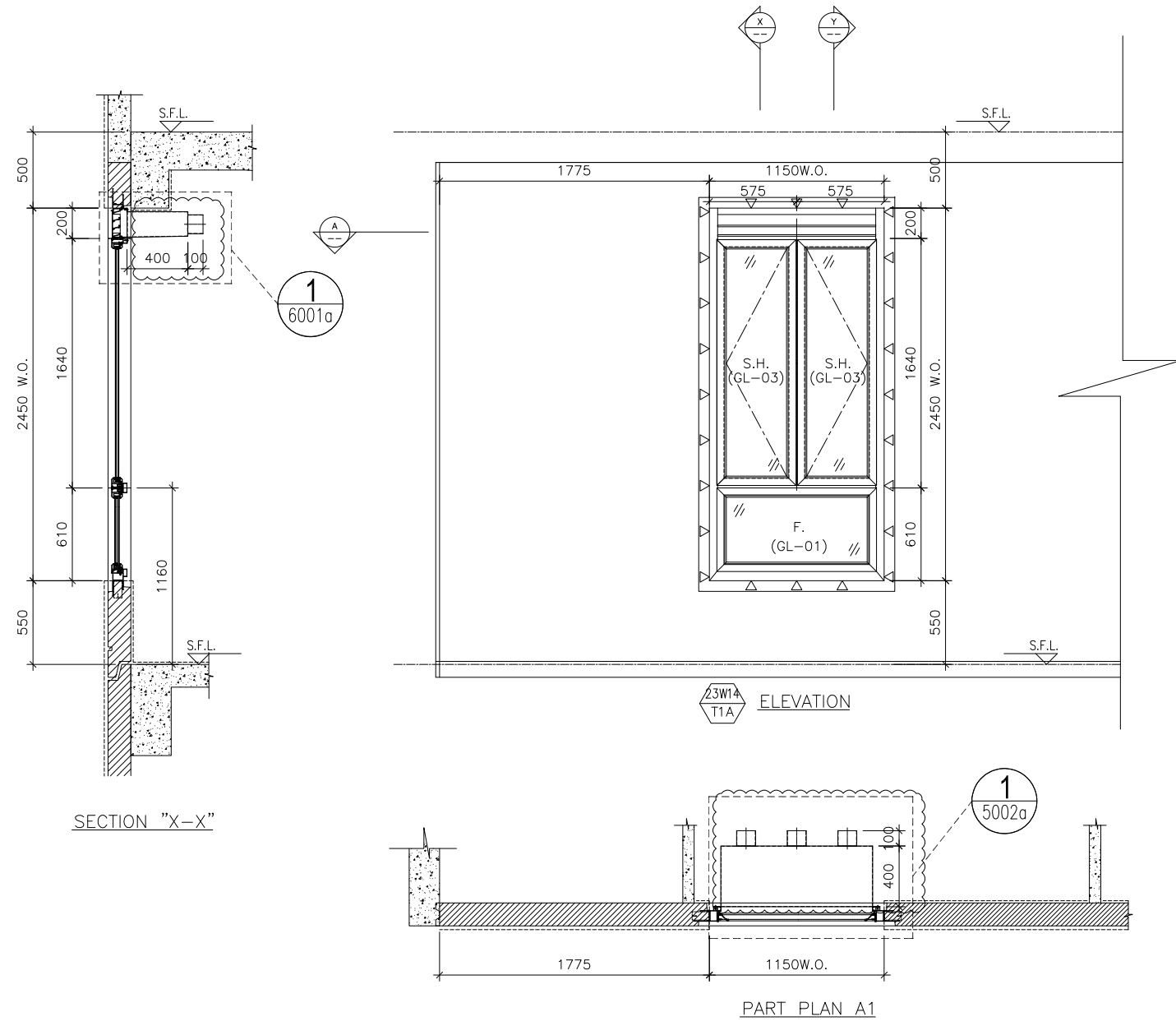

WINDOW MARK	
LOCATION	23/F M.B. & EN.B 3 AT TOWER 1 FLAT A
SECTION	70mm ALUM. SECTION
GLAZING	GL-01, GL-03
QUANTITY	1
REMARKS	FACADE (PF-22)

B.D. REF :

CLIENT :

ARCHITECT :

 AGC DESIGN LTD
 101, 102, 103, 104, 105, 106, 107, 108, 109, 110, 111, 112, 113, 114, 115, 116, 117, 118, 119, 120, 121, 122, 123, 124, 125, 126, 127, 128, 129, 130, 131, 132, 133, 134, 135, 136, 137, 138, 139, 140, 141, 142, 143, 144, 145, 146, 147, 148, 149, 150, 151, 152, 153, 154, 155, 156, 157, 158, 159, 160, 161, 162, 163, 164, 165, 166, 167, 168, 169, 170, 171, 172, 173, 174, 175, 176, 177, 178, 179, 180, 181, 182, 183, 184, 185, 186, 187, 188, 189, 190, 191, 192, 193, 194, 195, 196, 197, 198, 199, 200, 201, 202, 203, 204, 205, 206, 207, 208, 209, 210, 211, 212, 213, 214, 215, 216, 217, 218, 219, 220, 221, 222, 223, 224, 225, 226, 227, 228, 229, 230, 231, 232, 233, 234, 235, 236, 237, 238, 239, 240, 241, 242, 243, 244, 245, 246, 247, 248, 249, 250, 251, 252, 253, 254, 255, 256, 257, 258, 259, 260, 261, 262, 263, 264, 265, 266, 267, 268, 269, 270, 271, 272, 273, 274, 275, 276, 277, 278, 279, 280, 281, 282, 283, 284, 285, 286, 287, 288, 289, 290, 291, 292, 293, 294, 295, 296, 297, 298, 299, 300, 301, 302, 303, 304, 305, 306, 307, 308, 309, 310, 311, 312, 313, 314, 315, 316, 317, 318, 319, 320, 321, 322, 323, 324, 325, 326, 327, 328, 329, 330, 331, 332, 333, 334, 335, 336, 337, 338, 339, 340, 341, 342, 343, 344, 345, 346, 347, 348, 349, 350, 351, 352, 353, 354, 355, 356, 357, 358, 359, 360, 361, 362, 363, 364, 365, 366, 367, 368, 369, 370, 371, 372, 373, 374, 375, 376, 377, 378, 379, 380, 381, 382, 383, 384, 385, 386, 387, 388, 389, 390, 391, 392, 393, 394, 395, 396, 397, 398, 399, 400, 401, 402, 403, 404, 405, 406, 407, 408, 409, 410, 411, 412, 413, 414, 415, 416, 417, 418, 419, 420, 421, 422, 423, 424, 425, 426, 427, 428, 429, 430, 431, 432, 433, 434, 435, 436, 437, 438, 439, 440, 441, 442, 443, 444, 445, 446, 447, 448, 449, 450, 451, 452, 453, 454, 455, 456, 457, 458, 459, 460, 461, 462, 463, 464, 465, 466, 467, 468, 469, 470, 471, 472, 473, 474, 475, 476, 477, 478, 479, 480, 481, 482, 483, 484, 485, 486, 487, 488, 489, 490, 491, 492, 493, 494, 495, 496, 497, 498, 499, 500, 501, 502, 503, 504, 505, 506, 507, 508, 509, 510, 511, 512, 513, 514, 515, 516, 517, 518, 519, 520, 521, 522, 523, 524, 525, 526, 527, 528, 529, 530, 531, 532, 533, 534, 535, 536, 537, 538, 539, 540, 541, 542, 543, 544, 545, 546, 547, 548, 549, 550, 551, 552, 553, 554, 555, 556, 557, 558, 559, 560, 561, 562, 563, 564, 565, 566, 567, 568, 569, 570, 571, 572, 573, 574, 575, 576, 577, 578, 579, 580, 581, 582, 583, 584, 585, 586, 587, 588, 589, 590, 591, 592, 593, 594, 595, 596, 597, 598, 599, 600, 601, 602, 603, 604, 605, 606, 607, 608, 609, 610, 611, 612, 613, 614, 615, 616, 617, 618, 619, 620, 621, 622, 623, 624, 625, 626, 627, 628, 629, 630, 631, 632, 633, 634, 635, 636, 637, 638, 639, 640, 641, 642, 643, 644, 645, 646, 647, 648, 649, 650, 651, 652, 653, 654, 655, 656, 657, 658, 659, 660, 661, 662, 663, 664, 665, 666, 667, 668, 669, 670, 671, 672, 673, 674, 675, 676, 677, 678, 679, 680, 681, 682, 683, 684, 685, 686, 687, 688, 689, 690, 691, 692, 693, 694, 695, 696, 697, 698, 699, 700, 701, 702, 703, 704, 705, 706, 707, 708, 709, 710, 711, 712, 713, 714, 715, 716, 717, 718, 719, 720, 721, 722, 723, 724, 725, 726, 727, 728, 729, 730, 731, 732, 733, 734, 735, 736, 737, 738, 739, 740, 741, 742, 743, 744, 745, 746, 747, 748, 749, 750, 751, 752, 753, 754, 755, 756, 757, 758, 759, 760, 761, 762, 763, 764, 765, 766, 767, 768, 769, 770, 771, 772, 773, 774, 775, 776, 777, 778, 779, 780, 781, 782, 783, 784, 785, 786, 787, 788, 789, 790, 791, 792, 793, 794, 795, 796, 797, 798, 799, 800, 801, 802, 803, 804, 805, 806, 807, 808, 809, 810, 811, 812, 813, 814, 815, 816, 817, 818, 819, 820, 821, 822, 823, 824, 825, 826, 827, 828, 829, 830, 831, 832, 833, 834, 835, 836, 837, 838, 839, 840, 841, 842, 843, 844, 845, 846, 847, 848, 849, 850, 851, 852, 853, 854, 855, 856, 857, 858, 859, 860, 861, 862, 863, 864, 865, 866, 867, 868, 869, 870, 871, 872, 873, 874, 875, 876, 877, 878, 879, 880, 881, 882, 883, 884, 885, 886, 887, 888, 889, 890, 891, 892, 893, 894, 895, 896, 897, 898, 899, 900, 901, 902, 903, 904, 905, 906, 907, 908, 909, 910, 911, 912, 913, 914, 915, 916, 917, 918, 919, 920, 921, 922, 923, 924, 925, 926, 927, 928, 929, 930, 931, 932, 933, 934, 935, 936, 937, 938, 939, 940, 941, 942, 943, 944, 945, 946, 947, 948, 949, 950, 951, 952, 953, 954, 955, 956, 957, 958, 959, 960, 961, 962, 963, 964, 965, 966, 967, 968, 969, 970, 971, 972, 973, 974, 975, 976, 977, 978, 979, 980, 981, 982, 983, 984, 985, 986, 987, 988, 989, 990, 991, 992, 993, 994, 995, 996, 997, 998, 999, 1000

NOTE :

1. ALL DIMENSIONS ARE IN mm.
2. ALL ELEVATIONS ARE VIEWED FROM OUTSIDE.
3. ALL DIMENSIONS TO BE VERIFIED ON SITE BEFORE FABRICATION.

LEGEND :

x1 --- DETAIL MARK NO.
 x001 --- REFER SHEET NO.

1. F.F.L. --- FINISHED FLOOR LEVEL
2. S.F.L. --- STRUCTURAL FLOOR LEVEL
3. (R) --- REVERSED DETAIL
4. ▲ --- FIXING LOCATION
5. △ --- FIXING LUG LOCATION
6. GLASS LEGEND
 GL01 --- 8mm+12mm AIR GAP+10mm THK. I.G.U.
 GL01a --- 8mm+9mm AIR GAP+12mm THK. I.G.U.
 GL03 --- 6mm+12mm AIR GAP+6mm THK. I.G.U.
 GL04 --- 10mm THK. TEMPERED GLASS (PROTECTIVE BARRIER)
 GL05 --- 6mm+12mm AIR GAP+8mm THK. I.G.U.

A	09/12/2020	REVISION SUBJECT TO ARCH.COMMENT	lv
NO.	DATE	REVISION	BY

JOB NO. : J-852

PROJECT :
 PROPOSED RESIDENTIAL DEVELOPMENT
 AT 139 - 147 ARGYLE STREET,
 NKIL 6005, 6035 R.P., 6036 R.P.,
 6037 R.P. & 6038 R.P.

TITLE :
 SCHEDULE FOR Plenum Box
 AT TOWER 1

DATE : 05-Dec-19	SCALE : 1:40
DRAWN BY : MN	CHECKED BY : DW

MIDI ALUMINIUM FABRICATOR LTD.
 Units 6-8, Sunray Industrial Centre, 1/F
 610 Cha Kwo Ling Road, Kowloon
 Tel:23489211-4 Fax:(852)2727666

DWG NO. : J852-SD-PB-4112 REV. : A

ELEVATION

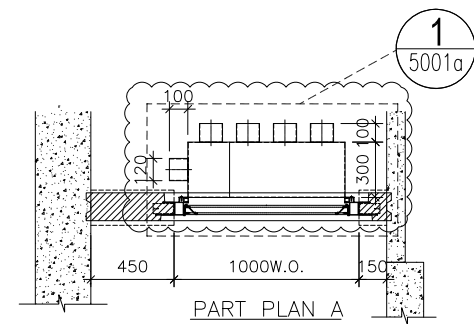
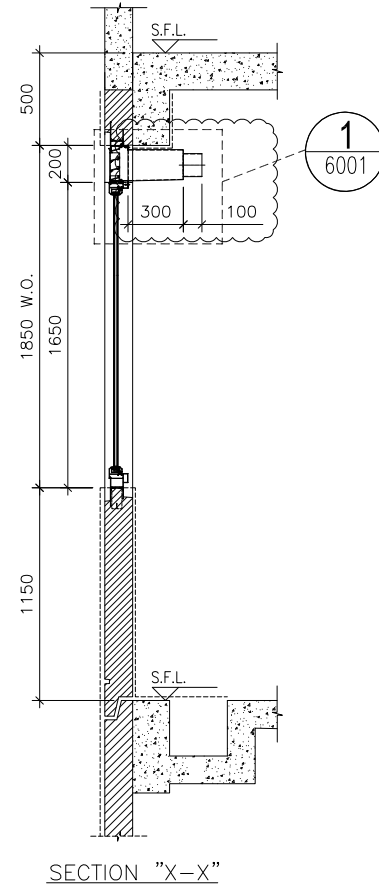
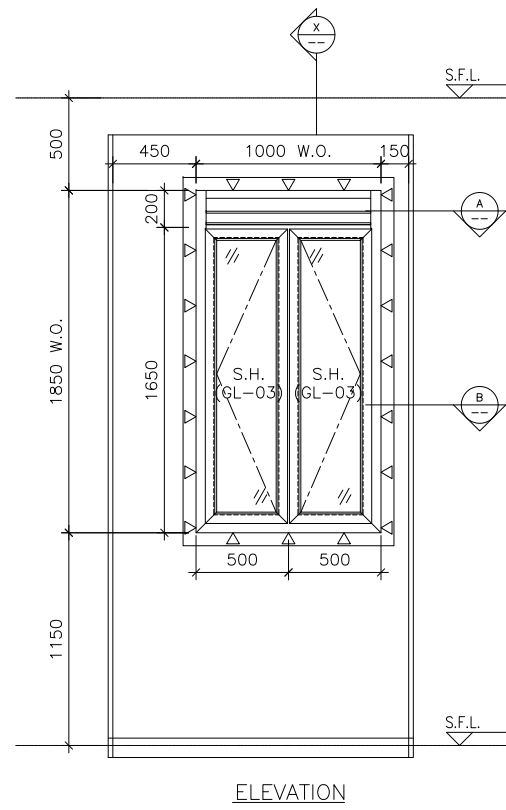

WINDOW MARK	
LOCATION	23/F KIT. AT TOWER 1 FLAT C
SECTION	70mm ALUM. SECTION
GLAZING	GL-03
QUANTITY	1
REMARKS	FACADE (PF-31)

B.D. REF :

CLIENT :

ARCHITECT :
AGC DESIGN LTD
 101, 102, 103, 104, 105, 106, 107, 108, 109, 110, 111, 112, 113, 114, 115, 116, 117, 118, 119, 120, 121, 122, 123, 124, 125, 126, 127, 128, 129, 130, 131, 132, 133, 134, 135, 136, 137, 138, 139, 140, 141, 142, 143, 144, 145, 146, 147, 148, 149, 150, 151, 152, 153, 154, 155, 156, 157, 158, 159, 160, 161, 162, 163, 164, 165, 166, 167, 168, 169, 170, 171, 172, 173, 174, 175, 176, 177, 178, 179, 180, 181, 182, 183, 184, 185, 186, 187, 188, 189, 190, 191, 192, 193, 194, 195, 196, 197, 198, 199, 200, 201, 202, 203, 204, 205, 206, 207, 208, 209, 210, 211, 212, 213, 214, 215, 216, 217, 218, 219, 220, 221, 222, 223, 224, 225, 226, 227, 228, 229, 230, 231, 232, 233, 234, 235, 236, 237, 238, 239, 240, 241, 242, 243, 244, 245, 246, 247, 248, 249, 250, 251, 252, 253, 254, 255, 256, 257, 258, 259, 260, 261, 262, 263, 264, 265, 266, 267, 268, 269, 270, 271, 272, 273, 274, 275, 276, 277, 278, 279, 280, 281, 282, 283, 284, 285, 286, 287, 288, 289, 290, 291, 292, 293, 294, 295, 296, 297, 298, 299, 300, 301, 302, 303, 304, 305, 306, 307, 308, 309, 310, 311, 312, 313, 314, 315, 316, 317, 318, 319, 320, 321, 322, 323, 324, 325, 326, 327, 328, 329, 330, 331, 332, 333, 334, 335, 336, 337, 338, 339, 340, 341, 342, 343, 344, 345, 346, 347, 348, 349, 350, 351, 352, 353, 354, 355, 356, 357, 358, 359, 360, 361, 362, 363, 364, 365, 366, 367, 368, 369, 370, 371, 372, 373, 374, 375, 376, 377, 378, 379, 380, 381, 382, 383, 384, 385, 386, 387, 388, 389, 390, 391, 392, 393, 394, 395, 396, 397, 398, 399, 400, 401, 402, 403, 404, 405, 406, 407, 408, 409, 410, 411, 412, 413, 414, 415, 416, 417, 418, 419, 420, 421, 422, 423, 424, 425, 426, 427, 428, 429, 430, 431, 432, 433, 434, 435, 436, 437, 438, 439, 440, 441, 442, 443, 444, 445, 446, 447, 448, 449, 450, 451, 452, 453, 454, 455, 456, 457, 458, 459, 460, 461, 462, 463, 464, 465, 466, 467, 468, 469, 470, 471, 472, 473, 474, 475, 476, 477, 478, 479, 480, 481, 482, 483, 484, 485, 486, 487, 488, 489, 490, 491, 492, 493, 494, 495, 496, 497, 498, 499, 500, 501, 502, 503, 504, 505, 506, 507, 508, 509, 510, 511, 512, 513, 514, 515, 516, 517, 518, 519, 520, 521, 522, 523, 524, 525, 526, 527, 528, 529, 530, 531, 532, 533, 534, 535, 536, 537, 538, 539, 540, 541, 542, 543, 544, 545, 546, 547, 548, 549, 550, 551, 552, 553, 554, 555, 556, 557, 558, 559, 560, 561, 562, 563, 564, 565, 566, 567, 568, 569, 570, 571, 572, 573, 574, 575, 576, 577, 578, 579, 580, 581, 582, 583, 584, 585, 586, 587, 588, 589, 590, 591, 592, 593, 594, 595, 596, 597, 598, 599, 600, 601, 602, 603, 604, 605, 606, 607, 608, 609, 610, 611, 612, 613, 614, 615, 616, 617, 618, 619, 620, 621, 622, 623, 624, 625, 626, 627, 628, 629, 630, 631, 632, 633, 634, 635, 636, 637, 638, 639, 640, 641, 642, 643, 644, 645, 646, 647, 648, 649, 650, 651, 652, 653, 654, 655, 656, 657, 658, 659, 660, 661, 662, 663, 664, 665, 666, 667, 668, 669, 670, 671, 672, 673, 674, 675, 676, 677, 678, 679, 680, 681, 682, 683, 684, 685, 686, 687, 688, 689, 690, 691, 692, 693, 694, 695, 696, 697, 698, 699, 700, 701, 702, 703, 704, 705, 706, 707, 708, 709, 710, 711, 712, 713, 714, 715, 716, 717, 718, 719, 720, 721, 722, 723, 724, 725, 726, 727, 728, 729, 730, 731, 732, 733, 734, 735, 736, 737, 738, 739, 740, 741, 742, 743, 744, 745, 746, 747, 748, 749, 750, 751, 752, 753, 754, 755, 756, 757, 758, 759, 760, 761, 762, 763, 764, 765, 766, 767, 768, 769, 770, 771, 772, 773, 774, 775, 776, 777, 778, 779, 780, 781, 782, 783, 784, 785, 786, 787, 788, 789, 790, 791, 792, 793, 794, 795, 796, 797, 798, 799, 800, 801, 802, 803, 804, 805, 806, 807, 808, 809, 810, 811, 812, 813, 814, 815, 816, 817, 818, 819, 820, 821, 822, 823, 824, 825, 826, 827, 828, 829, 830, 831, 832, 833, 834, 835, 836, 837, 838, 839, 840, 841, 842, 843, 844, 845, 846, 847, 848, 849, 850, 851, 852, 853, 854, 855, 856, 857, 858, 859, 860, 861, 862, 863, 864, 865, 866, 867, 868, 869, 870, 871, 872, 873, 874, 875, 876, 877, 878, 879, 880, 881, 882, 883, 884, 885, 886, 887, 888, 889, 890, 891, 892, 893, 894, 895, 896, 897, 898, 899, 900, 901, 902, 903, 904, 905, 906, 907, 908, 909, 910, 911, 912, 913, 914, 915, 916, 917, 918, 919, 920, 921, 922, 923, 924, 925, 926, 927, 928, 929, 930, 931, 932, 933, 934, 935, 936, 937, 938, 939, 940, 941, 942, 943, 944, 945, 946, 947, 948, 949, 950, 951, 952, 953, 954, 955, 956, 957, 958, 959, 960, 961, 962, 963, 964, 965, 966, 967, 968, 969, 970, 971, 972, 973, 974, 975, 976, 977, 978, 979, 980, 981, 982, 983, 984, 985, 986, 987, 988, 989, 990, 991, 992, 993, 994, 995, 996, 997, 998, 999, 1000

MAIN CONTRACTOR :
Gammon

STRUCTURAL ENGINEER :
ARUP

FACADE CONSULTANT:
MEINHARDT

NOTE :
 1. ALL DIMENSIONS ARE IN mm.
 2. ALL ELEVATIONS ARE VIEWED FROM OUTSIDE.
 3. ALL DIMENSIONS TO BE VERIFIED ON SITE BEFORE FABRICATION.

LEGEND :
 (x1) --- DETAIL MARK NO.
 (x001) --- REFER SHEET NO.
 1. F.F.L. --- FINISHED FLOOR LEVEL
 2. S.F.L. --- STRUCTURAL FLOOR LEVEL
 3. (R) --- REVERSED DETAIL
 4. ▲ --- FIXING LOCATION
 5. △ --- FIXING LUG LOCATION
 6. GLASS LEGEND
 GL01 --- 8mm+12mm AIR GAP+10mm THK. I.G.U.
 GL01a --- 8mm+9mm AIR GAP+12mm THK. I.G.U.
 GL03 --- 6mm+12mm AIR GAP+6mm THK. I.G.U.
 GL04 --- 10mm THK. TEMPERED GLASS (PROTECTIVE BARRIER)
 GL05 --- 6mm+12mm AIR GAP+8mm THK. I.G.U.

NO.	DATE	REVISION	BY
A	09/12/2020	REVISION SUBJECT TO ARCH.COMMENT	Ivan

JOB NO. : J-852
 PROJECT :
 PROPOSED RESIDENTIAL DEVELOPMENT
 AT 139 - 147 ARGYLE STREET,
 NKIL 6005, 6035 R.P., 6036 R.P.,
 6037 R.P. & 6038 R.P.

TITLE :
 SCHEDULE FOR Plenum Box
 AT TOWER 1

DATE : 05-Dec-19 SCALE : 1:40
 DRAWN BY : MN CHECKED BY : DW

美特鋁質有限公司
MIDI ALUMINIUM FABRICATOR LTD.
 Units 6-8, Sunray Industrial Centre, 1/F
 610 Cha Kwo Ling Road, Kowloon
 Tel:23489211-4 Fax:(852)2727666
 DWG NO. : J852-SD-PB-4113 REV. : A

ELEVATION

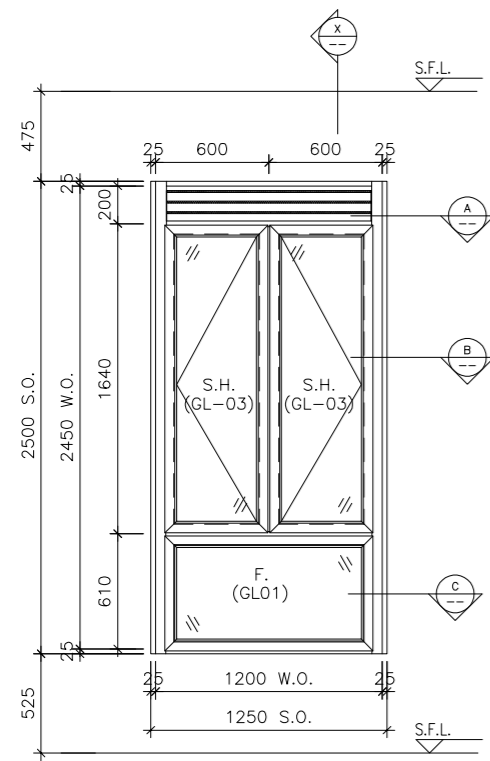

ELEVATION

1
5006

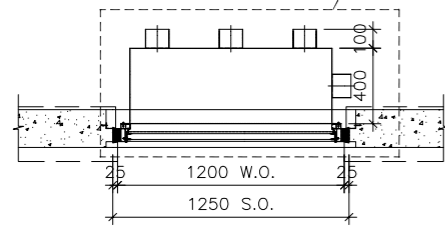

PART PLAN A

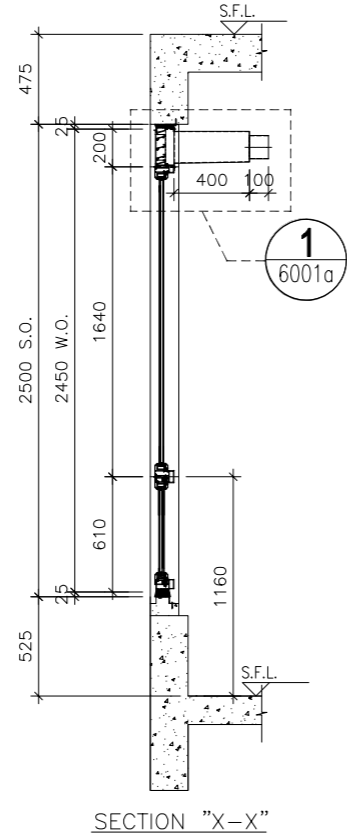

SECTION "X-X"

B.D. REF :

CLIENT :

ARCHITECT :
AGC DESIGN LTD
 1001, 14/F, Ocean Plaza, 225, King's Road, North Point, Hong Kong
 Tel: (852)27797812, Fax: (852)27797133, Email: agc@agc.com.hk

MAIN CONTRACTOR :
Gammon

STRUCTURAL ENGINEER :
ARUP

FACADE CONSULTANT:
MEINHARDT

NOTE :
 1. ALL DIMENSIONS ARE IN mm.
 2. ALL ELEVATIONS ARE VIEWED FROM OUTSIDE.
 3. ALL DIMENSIONS TO BE VERIFIED ON SITE BEFORE FABRICATION.

LEGEND :
 X1 --- DETAIL MARK NO.
 X001 --- REFER SHEET NO.
 1. F.F.L. --- FINISHED FLOOR LEVEL
 2. S.F.L. --- STRUCTURAL FLOOR LEVEL
 3. (R) --- REVERSED DETAIL

NO.	DATE	REVISED	BY
-----	------	---------	----

JOB NO. : J-852
 PROJECT : PROPOSED RESIDENTIAL DEVELOPMENT AT 139 - 147 ARGYLE STREET, NKIL 6005, 6035 R.P., 6036 R.P., 6037 R.P. & 6038 R.P.

TITLE : SCHEDULE FOR Plenum Box At IN-SITU ALUM. WINDOW(T1-23F)

DATE : 05-FEB-20 SCALE : 1:100
 DRAWN BY : MN CHECKED BY : DW

美特鋁質有限公司
MIDI ALUMINIUM FABRICATOR LTD.
 Units 6-8, Sunray Industrial Centre, 1/F
 610 Cha Kwo Ling Road, Kowloon
 Tel:23489211-4 Fax:(852)27727666

WINDOW MARK	23W6 T1A
LOCATION	23/F BATH AT TOWER 1 FLAT A
SECTION	70mm ALUM. SECTION
GLAZING	GL-01, GL-03
QUANTITY	1
REMARKS	

DWG NO. : J852-SD-PB-4114 REV. : -

ELEVATION

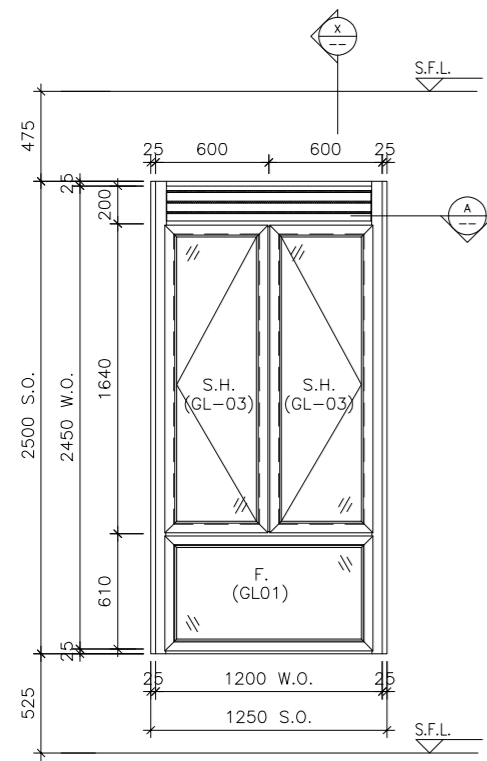

ELEVATION

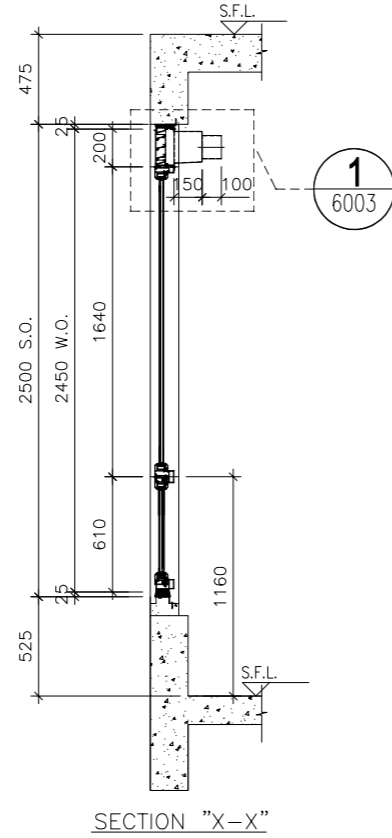

SECTION "X-X"

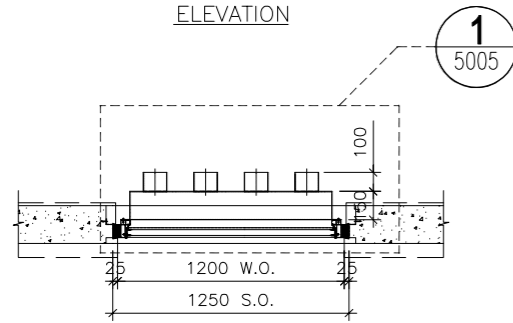

PART PLAN A

WINDOW MARK



LOCATION 23/F EN. B 3 AT TOWER 1 FLAT A

SECTION 70mm ALUM. SECTION

GLAZING GL-01, GL-03

QUANTITY 1

REMARKS

B.D. REF :

CLIENT :

ARCHITECT :
AGC DESIGN LTD
 1001, 14/F, Ocean Plaza, 225, King's Road, North Point, Hong Kong
 Tel: (852)2779788, Fax: (852)2779788, Email: agc@agc.com.hk

MAIN CONTRACTOR :
Gammon

STRUCTURAL ENGINEER :
ARUP

FACADE CONSULTANT:
MEINHARDT

NOTE :
 1. ALL DIMENSIONS ARE IN mm.
 2. ALL ELEVATIONS ARE VIEWED FROM OUTSIDE.
 3. ALL DIMENSIONS TO BE VERIFIED ON SITE BEFORE FABRICATION.

LEGEND :
 X1 --- DETAIL MARK NO.
 X001 --- REFER SHEET NO.
 1. F.F.L. --- FINISHED FLOOR LEVEL
 2. S.F.L. --- STRUCTURAL FLOOR LEVEL
 3. (R) --- REVERSED DETAIL

NO.	DATE	REVISED	BY
-----	------	---------	----

JOB NO. : J-852
 PROJECT : PROPOSED RESIDENTIAL DEVELOPMENT AT 139 - 147 ARGYLE STREET, NKIL 6005, 6035 R.P., 6036 R.P., 6037 R.P. & 6038 R.P.

TITLE : SCHEDULE FOR Plenum Box At IN-SITU ALUM. WINDOW(T1-23F)

DATE : 05-FEB-20 SCALE : 1:100

DRAWN BY : MN CHECKED BY : DW

美特鋁質有限公司
MIDI ALUMINIUM FABRICATOR LTD.
 Units 6-8, Sunray Industrial Centre, 1/F
 610 Cha Kwo Ling Road, Kowloon
 Tel:23489211-4 Fax:(852)27727666

DWG NO. : J852-SD-PB-4115 REV. : -

ELEVATION

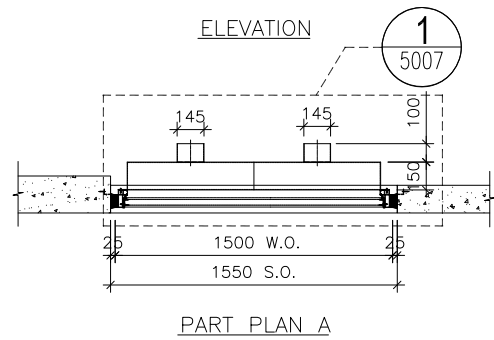
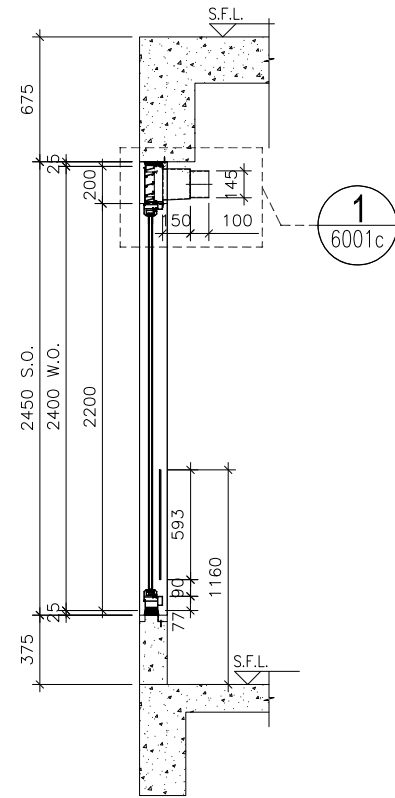
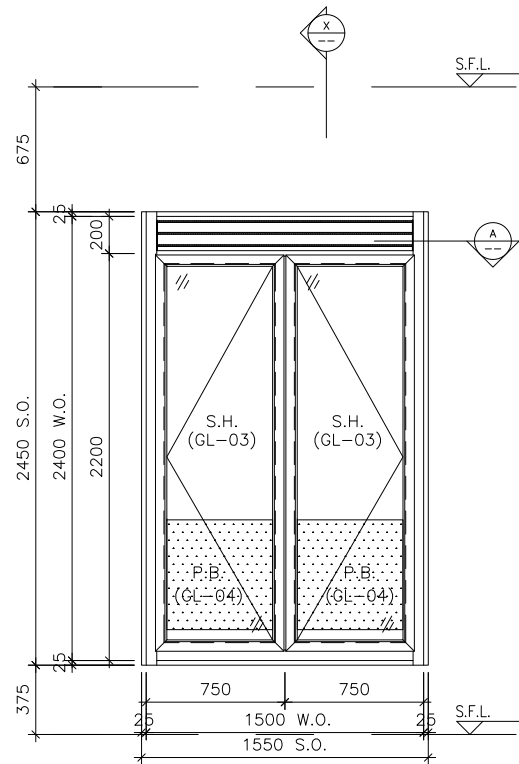

SECTION "X-X"

PART PLAN A

WINDOW MARK	
LOCATION	23/F KIT. AT TOWER 1 FLAT A
SECTION	70mm ALUM. SECTION
GLAZING	GL-01, GL-03
QUANTITY	1
REMARKS	

B.D. REF :

CLIENT :

ARCHITECT :
AGC DESIGN LTD
 101, 102, 103, 104, 105, 106, 107, 108, 109, 110, 111, 112, 113, 114, 115, 116, 117, 118, 119, 120, 121, 122, 123, 124, 125, 126, 127, 128, 129, 130, 131, 132, 133, 134, 135, 136, 137, 138, 139, 140, 141, 142, 143, 144, 145, 146, 147, 148, 149, 150, 151, 152, 153, 154, 155, 156, 157, 158, 159, 160, 161, 162, 163, 164, 165, 166, 167, 168, 169, 170, 171, 172, 173, 174, 175, 176, 177, 178, 179, 180, 181, 182, 183, 184, 185, 186, 187, 188, 189, 190, 191, 192, 193, 194, 195, 196, 197, 198, 199, 200, 201, 202, 203, 204, 205, 206, 207, 208, 209, 210, 211, 212, 213, 214, 215, 216, 217, 218, 219, 220, 221, 222, 223, 224, 225, 226, 227, 228, 229, 230, 231, 232, 233, 234, 235, 236, 237, 238, 239, 240, 241, 242, 243, 244, 245, 246, 247, 248, 249, 250, 251, 252, 253, 254, 255, 256, 257, 258, 259, 260, 261, 262, 263, 264, 265, 266, 267, 268, 269, 270, 271, 272, 273, 274, 275, 276, 277, 278, 279, 280, 281, 282, 283, 284, 285, 286, 287, 288, 289, 290, 291, 292, 293, 294, 295, 296, 297, 298, 299, 300, 301, 302, 303, 304, 305, 306, 307, 308, 309, 310, 311, 312, 313, 314, 315, 316, 317, 318, 319, 320, 321, 322, 323, 324, 325, 326, 327, 328, 329, 330, 331, 332, 333, 334, 335, 336, 337, 338, 339, 340, 341, 342, 343, 344, 345, 346, 347, 348, 349, 350, 351, 352, 353, 354, 355, 356, 357, 358, 359, 360, 361, 362, 363, 364, 365, 366, 367, 368, 369, 370, 371, 372, 373, 374, 375, 376, 377, 378, 379, 380, 381, 382, 383, 384, 385, 386, 387, 388, 389, 390, 391, 392, 393, 394, 395, 396, 397, 398, 399, 400, 401, 402, 403, 404, 405, 406, 407, 408, 409, 410, 411, 412, 413, 414, 415, 416, 417, 418, 419, 420, 421, 422, 423, 424, 425, 426, 427, 428, 429, 430, 431, 432, 433, 434, 435, 436, 437, 438, 439, 440, 441, 442, 443, 444, 445, 446, 447, 448, 449, 450, 451, 452, 453, 454, 455, 456, 457, 458, 459, 460, 461, 462, 463, 464, 465, 466, 467, 468, 469, 470, 471, 472, 473, 474, 475, 476, 477, 478, 479, 480, 481, 482, 483, 484, 485, 486, 487, 488, 489, 490, 491, 492, 493, 494, 495, 496, 497, 498, 499, 500, 501, 502, 503, 504, 505, 506, 507, 508, 509, 510, 511, 512, 513, 514, 515, 516, 517, 518, 519, 520, 521, 522, 523, 524, 525, 526, 527, 528, 529, 530, 531, 532, 533, 534, 535, 536, 537, 538, 539, 540, 541, 542, 543, 544, 545, 546, 547, 548, 549, 550, 551, 552, 553, 554, 555, 556, 557, 558, 559, 560, 561, 562, 563, 564, 565, 566, 567, 568, 569, 570, 571, 572, 573, 574, 575, 576, 577, 578, 579, 580, 581, 582, 583, 584, 585, 586, 587, 588, 589, 590, 591, 592, 593, 594, 595, 596, 597, 598, 599, 600, 601, 602, 603, 604, 605, 606, 607, 608, 609, 610, 611, 612, 613, 614, 615, 616, 617, 618, 619, 620, 621, 622, 623, 624, 625, 626, 627, 628, 629, 630, 631, 632, 633, 634, 635, 636, 637, 638, 639, 640, 641, 642, 643, 644, 645, 646, 647, 648, 649, 650, 651, 652, 653, 654, 655, 656, 657, 658, 659, 660, 661, 662, 663, 664, 665, 666, 667, 668, 669, 670, 671, 672, 673, 674, 675, 676, 677, 678, 679, 680, 681, 682, 683, 684, 685, 686, 687, 688, 689, 690, 691, 692, 693, 694, 695, 696, 697, 698, 699, 700, 701, 702, 703, 704, 705, 706, 707, 708, 709, 710, 711, 712, 713, 714, 715, 716, 717, 718, 719, 720, 721, 722, 723, 724, 725, 726, 727, 728, 729, 730, 731, 732, 733, 734, 735, 736, 737, 738, 739, 740, 741, 742, 743, 744, 745, 746, 747, 748, 749, 750, 751, 752, 753, 754, 755, 756, 757, 758, 759, 760, 761, 762, 763, 764, 765, 766, 767, 768, 769, 770, 771, 772, 773, 774, 775, 776, 777, 778, 779, 780, 781, 782, 783, 784, 785, 786, 787, 788, 789, 790, 791, 792, 793, 794, 795, 796, 797, 798, 799, 800, 801, 802, 803, 804, 805, 806, 807, 808, 809, 810, 811, 812, 813, 814, 815, 816, 817, 818, 819, 820, 821, 822, 823, 824, 825, 826, 827, 828, 829, 830, 831, 832, 833, 834, 835, 836, 837, 838, 839, 840, 841, 842, 843, 844, 845, 846, 847, 848, 849, 850, 851, 852, 853, 854, 855, 856, 857, 858, 859, 860, 861, 862, 863, 864, 865, 866, 867, 868, 869, 870, 871, 872, 873, 874, 875, 876, 877, 878, 879, 880, 881, 882, 883, 884, 885, 886, 887, 888, 889, 890, 891, 892, 893, 894, 895, 896, 897, 898, 899, 900, 901, 902, 903, 904, 905, 906, 907, 908, 909, 910, 911, 912, 913, 914, 915, 916, 917, 918, 919, 920, 921, 922, 923, 924, 925, 926, 927, 928, 929, 930, 931, 932, 933, 934, 935, 936, 937, 938, 939, 940, 941, 942, 943, 944, 945, 946, 947, 948, 949, 950, 951, 952, 953, 954, 955, 956, 957, 958, 959, 960, 961, 962, 963, 964, 965, 966, 967, 968, 969, 970, 971, 972, 973, 974, 975, 976, 977, 978, 979, 980, 981, 982, 983, 984, 985, 986, 987, 988, 989, 990, 991, 992, 993, 994, 995, 996, 997, 998, 999, 1000

MAIN CONTRACTOR :
Gammon

STRUCTURAL ENGINEER :
ARUP

FACADE CONSULTANT:
MEINHARDT

NOTE :
 1. ALL DIMENSIONS ARE IN mm.
 2. ALL ELEVATIONS ARE VIEWED FROM OUTSIDE.
 3. ALL DIMENSIONS TO BE VERIFIED ON SITE BEFORE FABRICATION.

LEGEND :
 (X1) — DETAIL MARK NO.
 (X001) — REFER SHEET NO.

1. F.F.L. -- FINISHED FLOOR LEVEL
 2. S.F.L. -- STRUCTURAL FLOOR LEVEL
 3. (R) -- REVERSED DETAIL

NO.	DATE	REVISED	BY

JOB NO. : J-852

PROJECT :
 PROPOSED RESIDENTIAL DEVELOPMENT
 AT 139 - 147 ARGYLE STREET,
 NKIL 6005, 6035 R.P., 6036 R.P.,
 6037 R.P. & 6038 R.P.

TITLE :
 SCHEDULE FOR Plenum Box
 At IN-SITU ALUM. WINDOW(T1-23F)

DATE : 05-FEB-20 SCALE : 1:100

DRAWN BY : MN CHECKED BY : DW

美特鋁質有限公司
MIDI ALUMINIUM FABRICATOR LTD.
 Units 6-8, Sunray Industrial Centre, 1/F
 610 Cha Kwo Ling Road, Kowloon
 Tel:23489211-4 Fax:(852)2727666

DWG NO. : J852-SD-PB-4116 REV. : -

ELEVATION

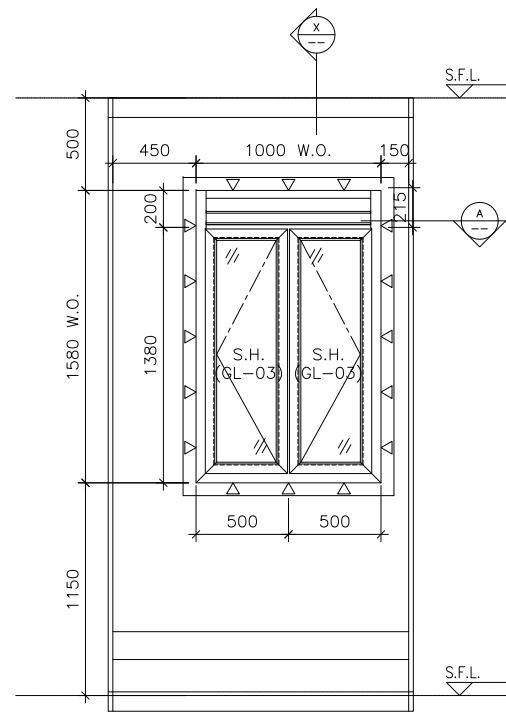

ELEVATION

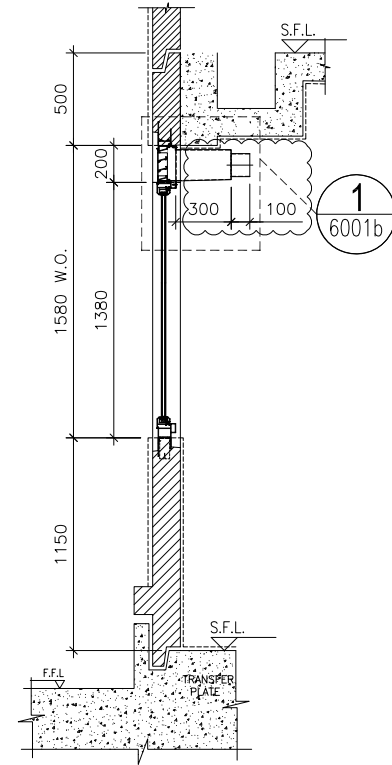

SECTION "X-X"

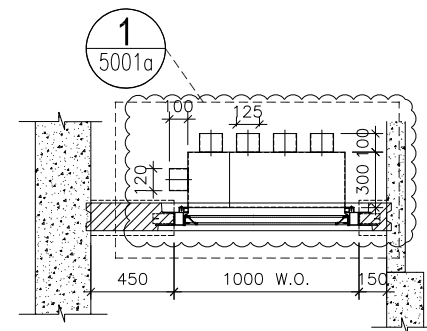

PART PLAN A

WINDOW MARK



LOCATION 1/F KIT. AT TOWER 2 FLAT C

SECTION 70mm ALUM. SECTION

GLAZING GL-03

QUANTITY 1

REMARKS FACADE (PF-28)

B.D. REF :

CLIENT :

ARCHITECT :

AGC
DESIGN LTD

MAIN CONTRACTOR :

Gammon

STRUCTURAL ENGINEER :

ARUP

FACADE CONSULTANT:

MEINHARDT

NOTE :

1. ALL DIMENSIONS ARE IN mm.
2. ALL ELEVATIONS ARE VIEWED FROM OUTSIDE.
3. ALL DIMENSIONS TO BE VERIFIED ON SITE BEFORE FABRICATION.

LEGEND :

- x1 --- DETAIL MARK NO.
- x001 --- REFER SHEET NO.

1. F.F.L. --- FINISHED FLOOR LEVEL
2. S.F.L. --- STRUCTURAL FLOOR LEVEL
3. (R) --- REVERSED DETAIL
4. ▲ --- FIXING LOCATION
5. △ --- FIXING LUG LOCATION

6. GLASS LEGEND

- GL01 --- 8mm+12mm AIR GAP+10mm THK. I.G.U.
- GL01a --- 8mm+9mm AIR GAP+10mm THK. I.G.U.
- GL03 --- 6mm+12mm AIR GAP+6mm THK. I.G.U.
- GL04 --- 10mm THK. TEMPERED GLASS (PROTECTIVE BARRIER)
- GL05 --- 6mm+12mm AIR GAP+8mm THK. I.G.U.

NO.	DATE	REVISION	BY
A	09/12/2020	REVISION SUBJECT TO ARCH.COMMENT	lvart

JOB NO. : J-852

PROJECT :
PROPOSED RESIDENTIAL DEVELOPMENT
AT 139 - 147 ARGYLE STREET,
NKIL 6005, 6035 R.P., 6036 R.P.,
6037 R.P. & 6038 R.P.

TITLE :
SCHEDULE FOR Plenum Box
AT TOWER 2 (1-21F)

DATE : 05-Dec-19 SCALE : 1:40

DRAWN BY : MN CHECKED BY : DW

美特鋁質有限公司
MIDI ALUMINIUM FABRICATOR LTD.
Units 6-8, Sunray Industrial Centre, 1/F
610 Cha Kwo Ling Road, Kowloon
Tel:23489211-4 Fax:(852)2727666

DWG NO. : J852-SD-PB-4201 REV. : A

ELEVATION

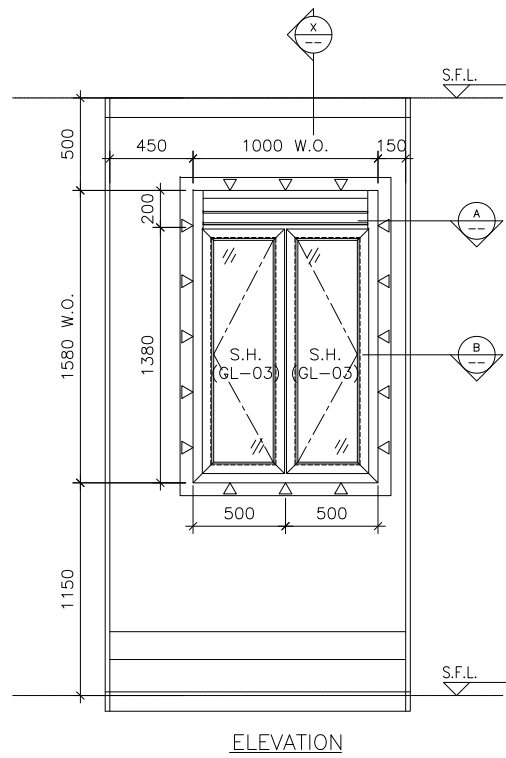

ELEVATION

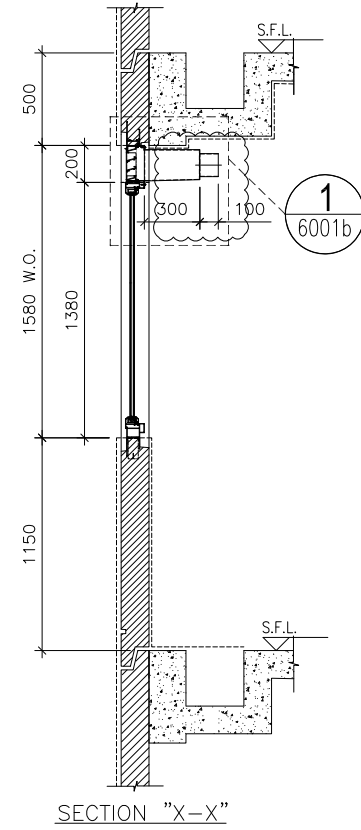

SECTION "X-X"

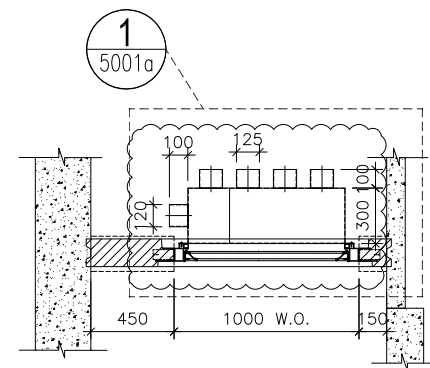

PART PLAN A

WINDOW MARK



LOCATION 2/F-21/F KIT. AT TOWER 2 FLAT C

SECTION 70mm ALUM. SECTION

GLAZING GL-03

QUANTITY 17

REMARKS FACADE (PF-28)

B.D. REF :

CLIENT :

ARCHITECT :

AGC
DESIGN LTD

MAIN CONTRACTOR :

Gammon

STRUCTURAL ENGINEER :

ARUP

FACADE CONSULTANT:

MEINHARDT

NOTE :

1. ALL DIMENSIONS ARE IN mm.
2. ALL ELEVATIONS ARE VIEWED FROM OUTSIDE.
3. ALL DIMENSIONS TO BE VERIFIED ON SITE BEFORE FABRICATION.

LEGEND :

- x1 --- DETAIL MARK NO.
- x001 --- REFER SHEET NO.

1. F.F.L. --- FINISHED FLOOR LEVEL
2. S.F.L. --- STRUCTURAL FLOOR LEVEL
3. (R) --- REVERSED DETAIL
4. ▲ --- FIXING LOCATION
5. △ --- FIXING LUG LOCATION

6. GLASS LEGEND

- GL01 --- 8mm+12mm AIR GAP+10mm THK. I.G.U.
- GL01a --- 8mm+9mm AIR GAP+10mm THK. I.G.U.
- GL03 --- 6mm+12mm AIR GAP+6mm THK. I.G.U.
- GL04 --- 10mm THK. TEMPERED GLASS (PROTECTIVE BARRIER)
- GL05 --- 6mm+12mm AIR GAP+8mm THK. I.G.U.

NO.	DATE	REVISION	BY
A	09/12/2020	REVISION SUBJECT TO ARCH.COMMENT	lvart

JOB NO. : J-852

PROJECT :
PROPOSED RESIDENTIAL DEVELOPMENT
AT 139 - 147 ARGYLE STREET,
NKIL 6005, 6035 R.P., 6036 R.P.,
6037 R.P. & 6038 R.P.

TITLE :
SCHEDULE FOR Plenum Box
AT TOWER 2 (1-21F)

DATE : 05-Dec-19 SCALE : 1:40

DRAWN BY : MN CHECKED BY : DW

美特鋁質有限公司
MIDI ALUMINIUM FABRICATOR LTD.
Units 6-8, Sunray Industrial Centre, 1/F
610 Cha Kwo Ling Road, Kowloon
Tel:23489211-4 Fax:(852)2727666

DWG NO. : J852-SD-PB-4201A REV. : A

B.D. REF :

CLIENT :

ARCHITECT :
AGC DESIGN LTD
 100, 14/F, Domain Place, 255 King's Road, North Point, Hong Kong
 Tel: (852) 27797882, Fax: (852) 27797823, Email: agc@agc.com.hk

MAIN CONTRACTOR :
Gammon

STRUCTURAL ENGINEER :
ARUP

FACADE CONSULTANT:
MEINHARDT

NOTE :
 1. ALL DIMENSIONS ARE IN mm.
 2. ALL ELEVATIONS ARE VIEWED FROM OUTSIDE.
 3. ALL DIMENSIONS TO BE VERIFIED ON SITE BEFORE FABRICATION.

LEGEND :
 X1 --- DETAIL MARK NO.
 X001 --- REFER SHEET NO.
 1. F.F.L. --- FINISHED FLOOR LEVEL
 2. S.F.L. --- STRUCTURAL FLOOR LEVEL
 3. (R) --- REVERSED DETAIL
 4. ▲ --- FIXING LOCATION
 5. △ --- FIXING LUG LOCATION
 6. GLASS LEGEND
 GL01 --- 8mm+12mm AIR GAP+10mm THK. I.G.U.
 GL01a --- 8mm+9mm AIR GAP+10mm THK. I.G.U.
 GL03 --- 6mm+12mm AIR GAP+6mm THK. I.G.U.
 GL04 --- 10mm THK. TEMPERED GLASS (PROTECTIVE BARRIER)
 GL05 --- 6mm+12mm AIR GAP+8mm THK. I.G.U.

A	07/11/2020	REVISION SUBJECT TO ARCH.COMMENT	Ivan
NO.	DATE	REVISED	BY

JOB NO. : J-852
 PROJECT :
 PROPOSED RESIDENTIAL DEVELOPMENT
 AT 139 - 147 ARGYLE STREET,
 NKIL 6005, 6035 R.P., 6036 R.P.,
 6037 R.P. & 6038 R.P.

TITLE :
 SCHEDULE FOR Plenum Box
 AT TOWER 2 (1-21F)

DATE : 05-Dec-19 SCALE : 1:40
 DRAWN BY : MN CHECKED BY : DW

美特鋁質有限公司
MIDI ALUMINIUM FABRICATOR LTD.
 Units 6-8, Sunray Industrial Centre, 1/F
 610 Cha Kwo Ling Road, Kowloon
 Tel: 23489211-4 Fax: (852) 27727666

DWG NO. : J852-SD-PB-4202 REV. : A

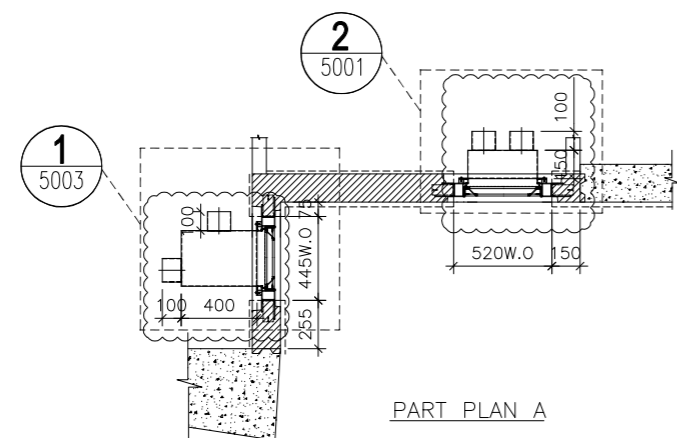
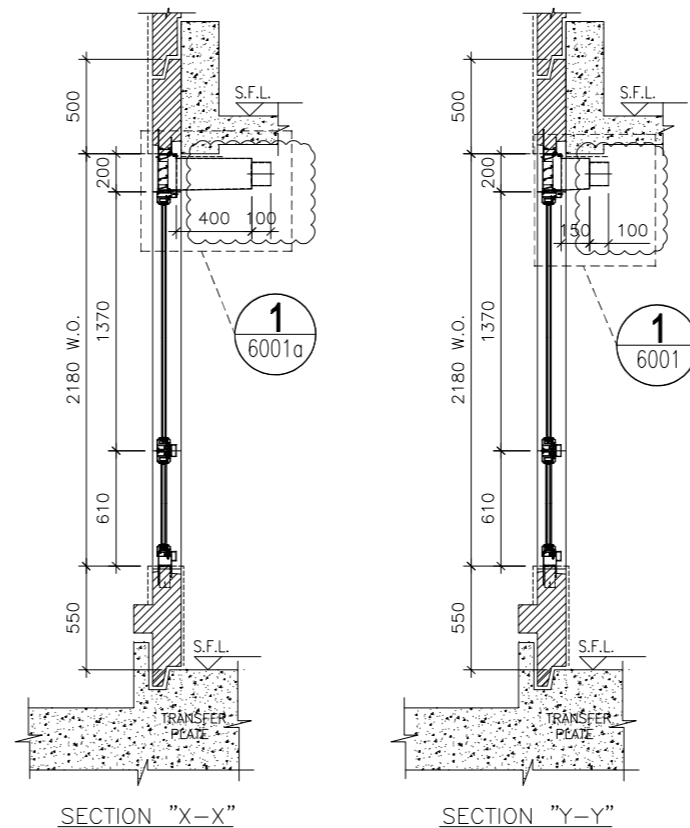
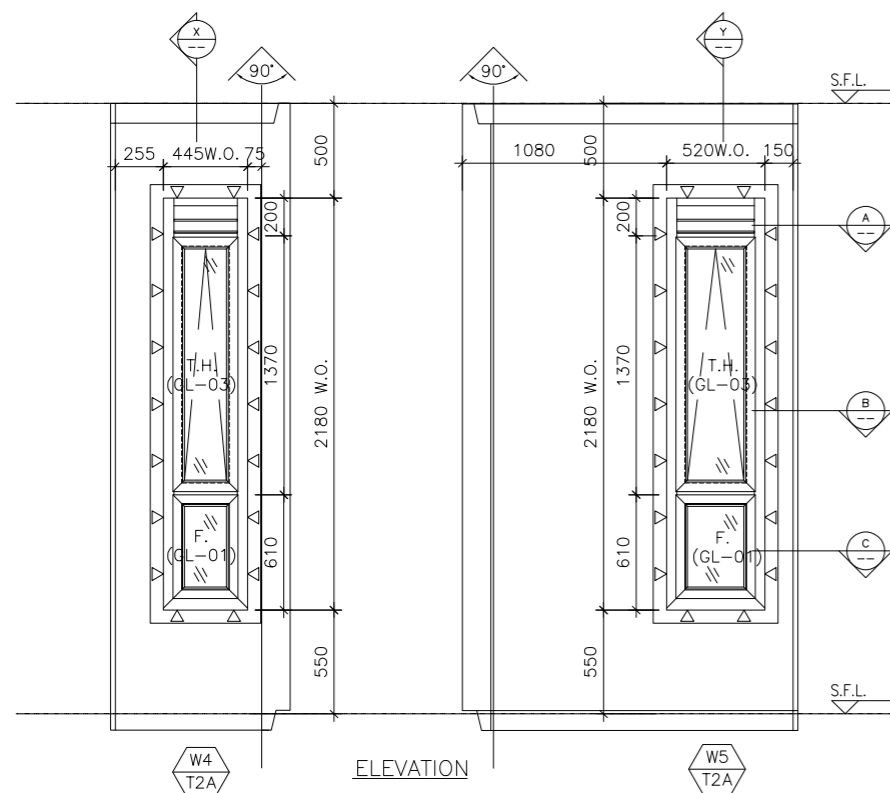

ELEVATION

WINDOW MARK
 W4 / W5
 T2A / T2A

LOCATION : 1/F M.B. & EN.B. AT TOWER 2 FLAT A
 SECTION : 70mm ALUM. SECTION
 GLAZING : GL-01, GL-03
 QUANTITY : 1 / 1
 REMARKS : FACADE (PF-35)

B.D. REF :

CLIENT :

ARCHITECT :
AGC DESIGN LTD
 100, 14/F, Dynasty Plaza, 225, King's Road, North Point, Hong Kong
 Tel: (852) 27791812, Fax: (852) 27791133, Email: agc@agc.com.hk

MAIN CONTRACTOR :
Gammon

STRUCTURAL ENGINEER :
ARUP

FACADE CONSULTANT:
MEINHARDT

NOTE :
 1. ALL DIMENSIONS ARE IN mm.
 2. ALL ELEVATIONS ARE VIEWED FROM OUTSIDE.
 3. ALL DIMENSIONS TO BE VERIFIED ON SITE BEFORE FABRICATION.

LEGEND :
 X1 --- DETAIL MARK NO.
 X001 --- REFER SHEET NO.
 1. F.F.L. --- FINISHED FLOOR LEVEL
 2. S.F.L. --- STRUCTURAL FLOOR LEVEL
 3. (R) --- REVERSED DETAIL
 4. ▲ --- FIXING LOCATION
 5. △ --- FIXING LUG LOCATION
 6. GLASS LEGEND
 GL01 --- 8mm+12mm AIR GAP+10mm THK. I.G.U.
 GL01a --- 8mm+9mm AIR GAP+10mm THK. I.G.U.
 GL03 --- 6mm+12mm AIR GAP+6mm THK. I.G.U.
 GL04 --- 10mm THK. TEMPERED GLASS (PROTECTIVE BARRIER)
 GL05 --- 6mm+12mm AIR GAP+8mm THK. I.G.U.

A	07/11/2020	REVISION SUBJECT TO ARCH.COMMENT	Ivan
NO.	DATE	REVISED	BY

JOB NO. : J-852
 PROJECT :
 PROPOSED RESIDENTIAL DEVELOPMENT
 AT 139 - 147 ARGYLE STREET,
 NKIL 6005, 6035 R.P., 6036 R.P.,
 6037 R.P. & 6038 R.P.
 TITLE :
 SCHEDULE FOR Plenum Box
 AT TOWER 2 (1-21F)

DATE : 05-Dec-19 SCALE : 1:40
 DRAWN BY : MN CHECKED BY : DW

美特鋁質有限公司
MIDI ALUMINIUM FABRICATOR LTD.
 Units 6-8, Sunray Industrial Centre, 1/F
 610 Cha Kwo Ling Road, Kowloon
 Tel: 23489211-4 Fax: (852) 27727666

DWG NO. : J852-SD-PB-4202A REV. : A

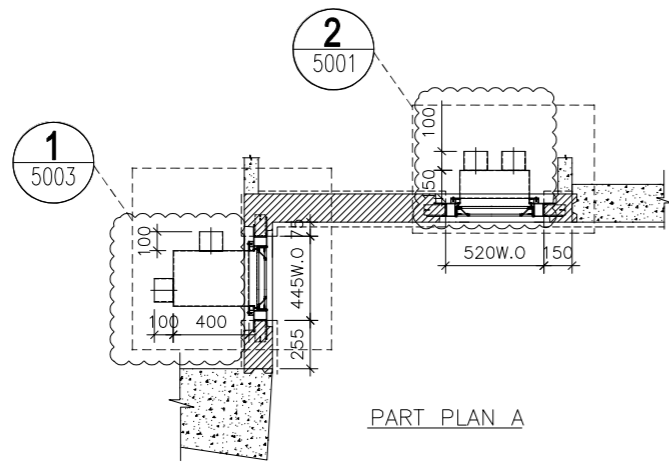
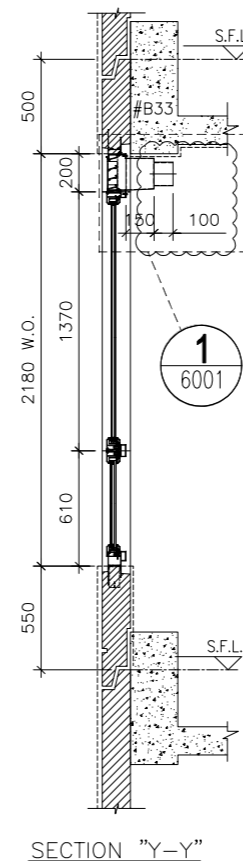
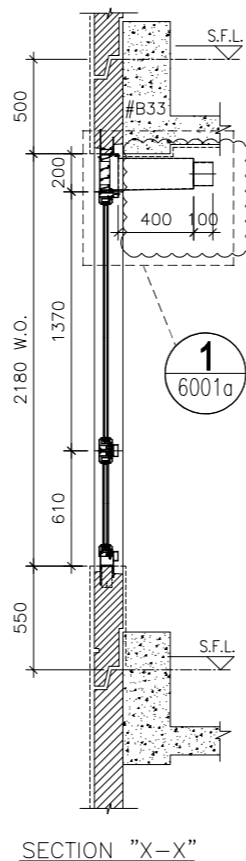
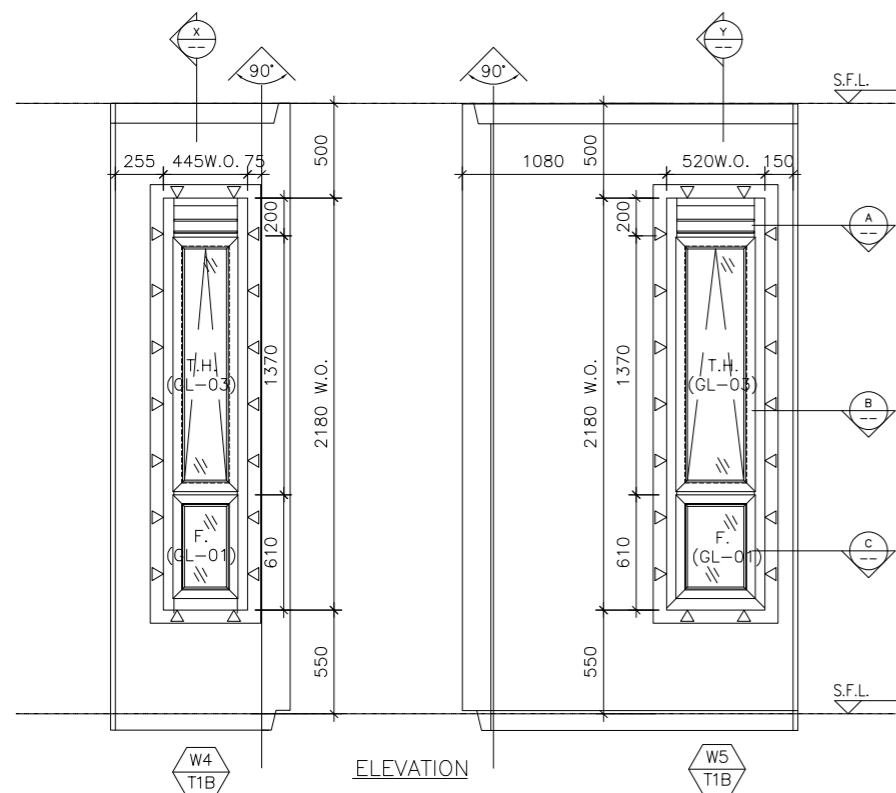

ELEVATION

WINDOW MARK	W4 / W5 T2A / T2A
LOCATION	2/F-21/F M.B. & EN.B. AT TOWER 2 FLAT A
SECTION	70mm ALUM. SECTION
GLAZING	GL-01, GL-03
QUANTITY	17 / 17
REMARKS	FACADE (PF-35)

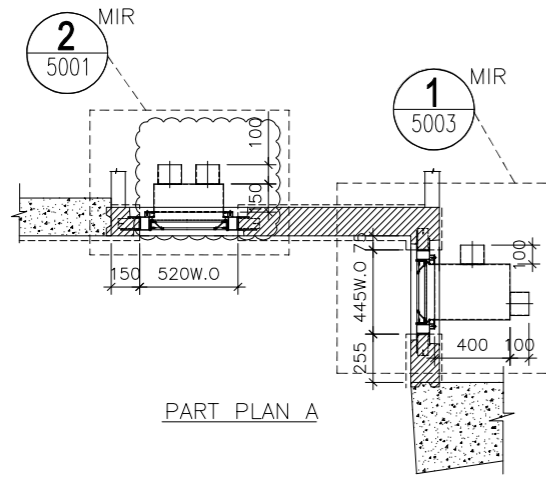
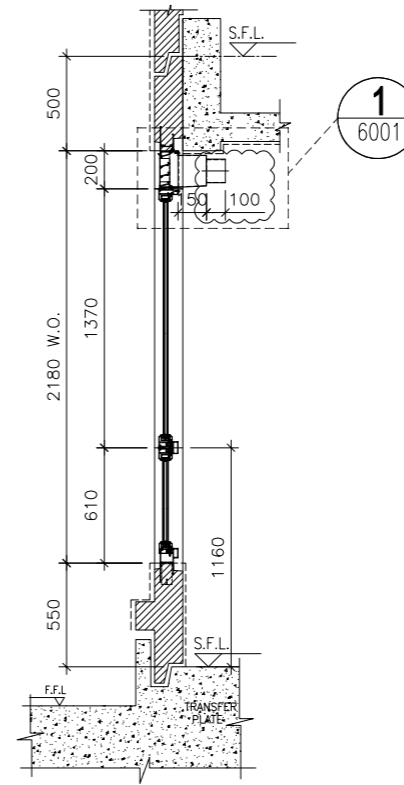
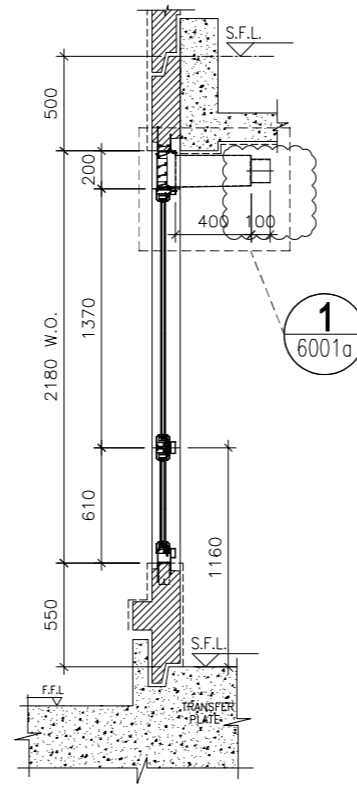
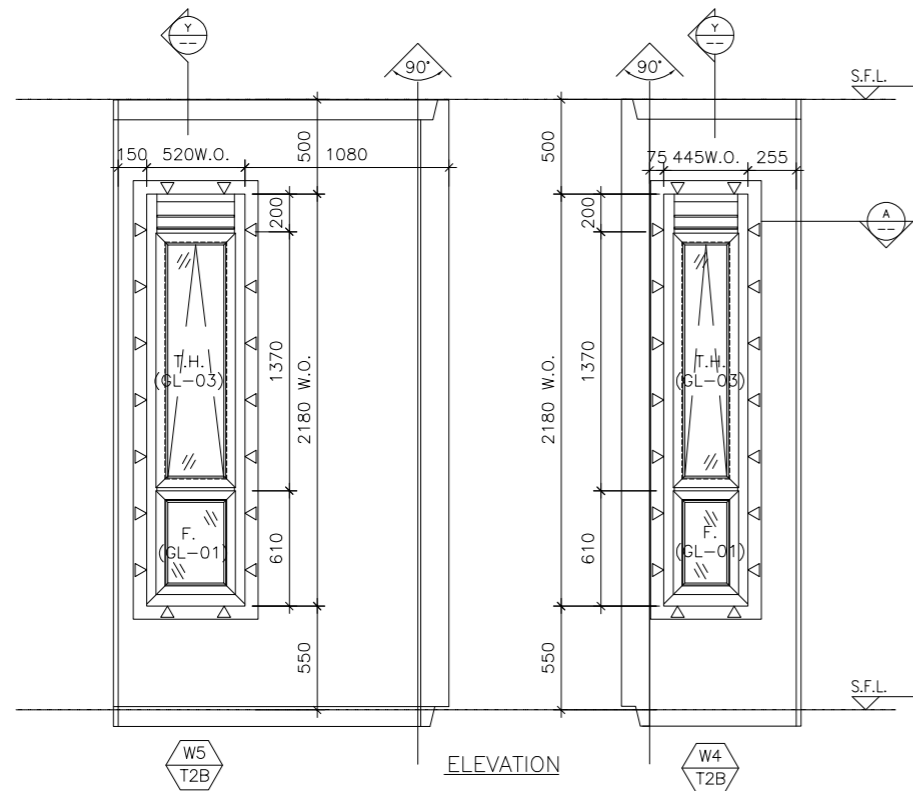

ELEVATION

SECTION "Y-Y"

SECTION "X-X"

PART PLAN A

B.D. REF :

CLIENT :

ARCHITECT :
AGC DESIGN LTD
 100, 14/F, Domain Place, 255 King's Road, North Point, Hong Kong
 Tel: (852)27797812, Fax: (852)27797133, Email: agc@agc.com.hk

MAIN CONTRACTOR :
Gammon

STRUCTURAL ENGINEER :
ARUP

FACADE CONSULTANT:
MEINHARDT

NOTE :
 1. ALL DIMENSIONS ARE IN mm.
 2. ALL ELEVATIONS ARE VIEWED FROM OUTSIDE.
 3. ALL DIMENSIONS TO BE VERIFIED ON SITE BEFORE FABRICATION.

LEGEND :
 X1 --- DETAIL MARK NO.
 X001 --- REFER SHEET NO.

1. F.F.L. --- FINISHED FLOOR LEVEL
 2. S.F.L. --- STRUCTURAL FLOOR LEVEL
 3. (R) --- REVERSED DETAIL

NO.	DATE	REVISION	SUBJECT TO ARCH.COMMENT	BY
A	07/11/2020	REVISION	SUBJECT TO ARCH.COMMENT	Ivan

JOB NO. : J-852
 PROJECT : PROPOSED RESIDENTIAL DEVELOPMENT AT 139 - 147 ARGYLE STREET, NKIL 6005, 6035 R.P., 6036 R.P., 6037 R.P. & 6038 R.P.
 TITLE : SCHEDULE FOR Plenum Box AT TOWER 2 (1-21F)

DATE : 05-Dec-19 SCALE : 1:40
 DRAWN BY : MN CHECKED BY : DW

美特鋁質有限公司
MIDI ALUMINIUM FABRICATOR LTD.
 Units 6-8, Sunray Industrial Centre, 1/F
 610 Cha Kwo Ling Road, Kowloon
 Tel:23489211-4 Fax:(852)27727666
 DWG NO. : J852-SD-PB-4203 REV. : A

WINDOW MARK	W5 / W4 T2B / T2B
LOCATION	1/F M.B. & EN.B. AT TOWER 2 FLAT B
SECTION	70mm ALUM. SECTION
GLAZING	GL-01, GL-03
QUANTITY	1 / 1
REMARKS	FACADE (PF-36)

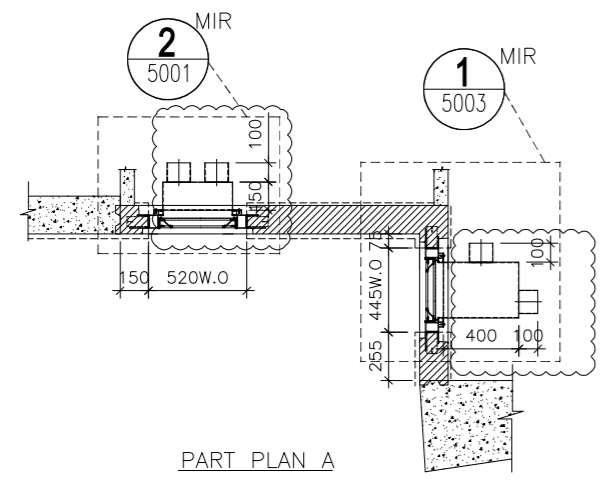
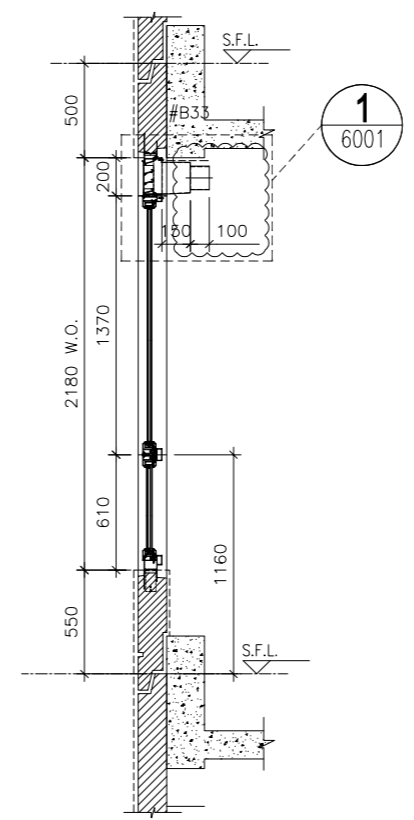
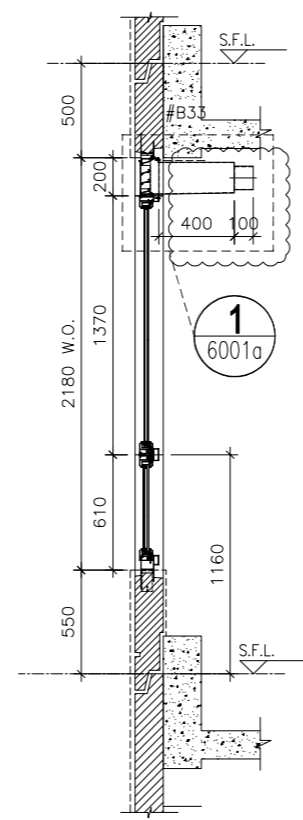
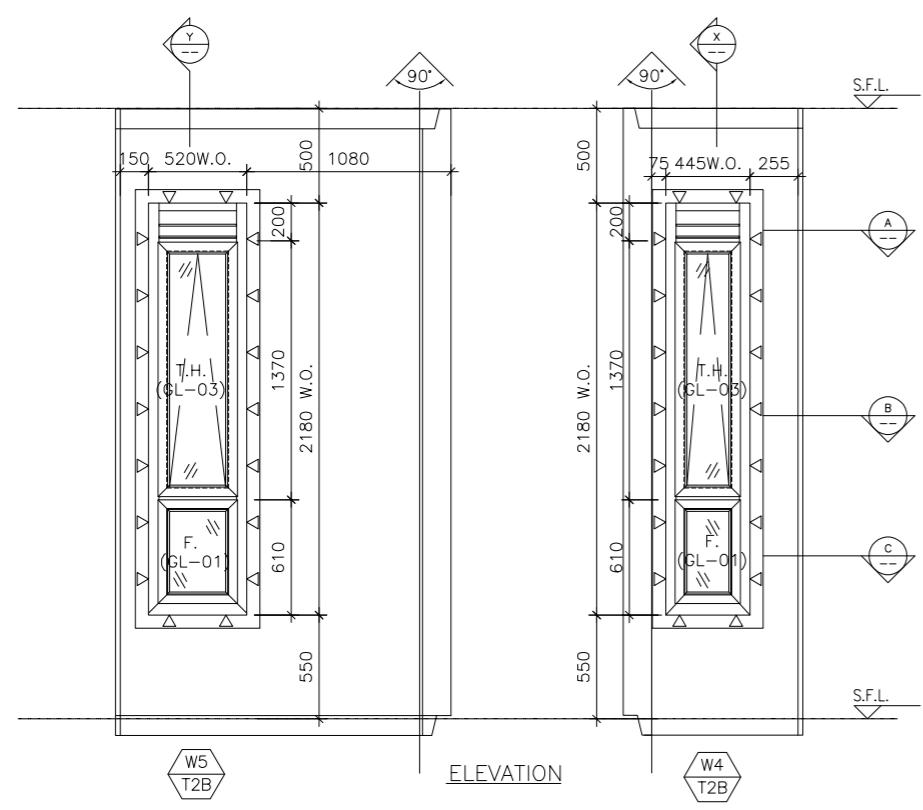

ELEVATION

SECTION "X-X"

SECTION "Y-Y"

PART PLAN A

B.D. REF :

CLIENT :

ARCHITECT :
AGC DESIGN LTD
 1001, 14/F, Oriental Plaza, 285 Hoi Sai Road, North Point, Hong Kong
 Tel: (852) 27797812, Fax: (852) 27791133, Email: agc@agc.com.hk

MAIN CONTRACTOR :
Gammon

STRUCTURAL ENGINEER :
ARUP

FACADE CONSULTANT:
MEINHARDT

NOTE :

1. ALL DIMENSIONS ARE IN mm.
2. ALL ELEVATIONS ARE VIEWED FROM OUTSIDE.
3. ALL DIMENSIONS TO BE VERIFIED ON SITE BEFORE FABRICATION.

LEGEND :

X1 — DETAIL MARK NO.
 X001 — REFER SHEET NO.

1. F.F.L. -- FINISHED FLOOR LEVEL
2. S.F.L. -- STRUCTURAL FLOOR LEVEL
3. (R) -- REVERSED DETAIL

NO.	DATE	REVISION	SUBJECT TO ARCH.COMMENT	BY
A	07/11/2020	REVISION	SUBJECT TO ARCH.COMMENT	Ivan

JOB NO. : J-852

PROJECT :
 PROPOSED RESIDENTIAL DEVELOPMENT
 AT 139 - 147 ARGYLE STREET,
 NKIL 6005, 6035 R.P., 6036 R.P.,
 6037 R.P. & 6038 R.P.

TITLE :
 SCHEDULE FOR Plenum Box
 AT TOWER 2 (1-21F)

DATE : 05-Dec-19 SCALE : 1:40

DRAWN BY : MN CHECKED BY : DW

美特鋁質有限公司
MIDI ALUMINIUM FABRICATOR LTD.
 Units 6-8, Sunray Industrial Centre, 1/F
 610 Cha Kwo Ling Road, Kowloon
 Tel: 23489211-4 Fax: (852) 27727666

DWG NO. : J852-SD-PB-4203A REV. : A

WINDOW MARK	W5 / W4 T2B / T2B
LOCATION	2/F-21/F M.B. & EN.B. AT TOWER 2 FLAT B
SECTION	70mm ALUM. SECTION
GLAZING	GL-01, GL-03
QUANTITY	17 / 17
REMARKS	FACADE (PF-36)

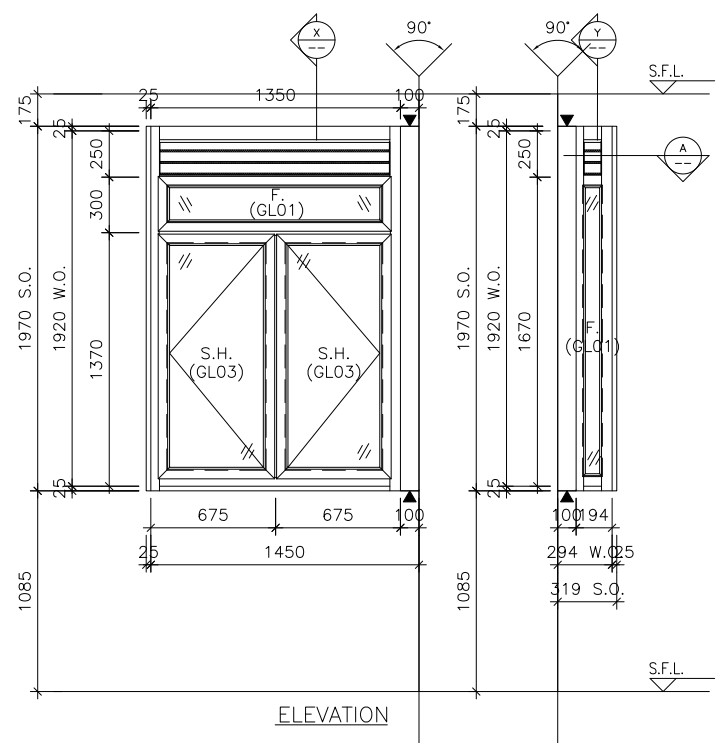

ELEVATION

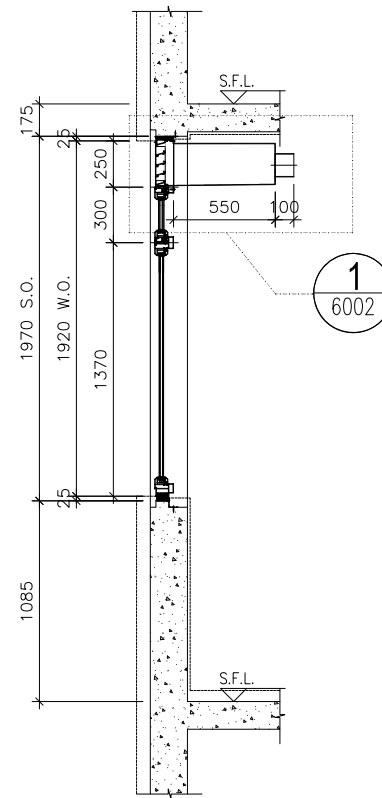

SECTION "X-X"

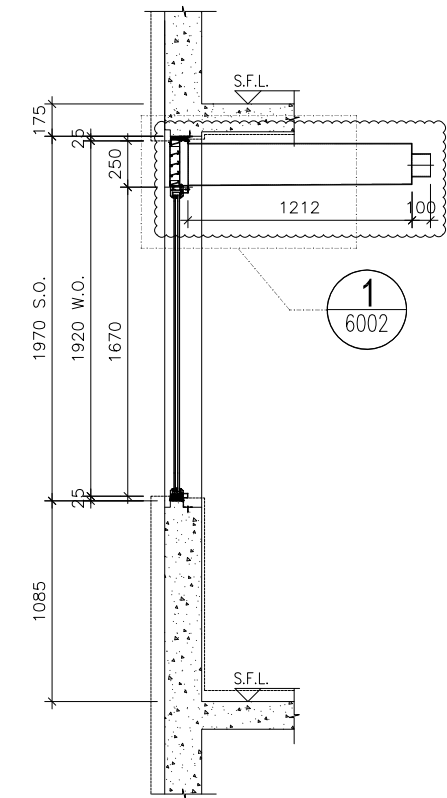

SECTION "Y-Y"

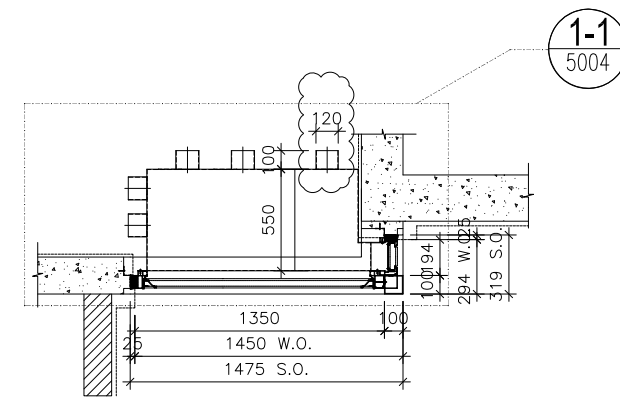

PART PLAN A

ELEVATION

WINDOW MARK	W8 T2A
LOCATION	1/F~21/F KIT. AT TOWER 2 FLAT A
SECTION	50mm ALUM. SECTION
GLAZING	GL01, GL03
QUANTITY	18
REMARKS	

B.D. REF :

CLIENT :

ARCHITECT :
AGC DESIGN LTD

MAIN CONTRACTOR :
Gammon

STRUCTURAL ENGINEER :
ARUP

FACADE CONSULTANT:
MEINHARDT

NOTE :

- ALL DIMENSIONS ARE IN mm.
- ALL ELEVATIONS ARE VIEWED FROM OUTSIDE.
- ALL DIMENSIONS TO BE VERIFIED ON SITE BEFORE FABRICATION.

LEGEND :

x1 --- DETAIL MARK NO.
x001 --- REFER SHEET NO.

- F.F.L. --- FINISHED FLOOR LEVEL
- S.F.L. --- STRUCTURAL FLOOR LEVEL
- (R) --- REVERSED DETAIL
- ▲ --- FIXING LOCATION
- △ --- FIXING LUG LOCATION

GLASS LEGEND

GL01 --- 8mm+12mm AIR GAP+10mm THK. I.G.U.
GL01a --- 8mm+9mm AIR GAP+10mm THK. I.G.U.
GL03 --- 6mm+12mm AIR GAP+6mm THK. I.G.U.
GL04 --- 10mm THK. TEMPERED GLASS (PROTECTIVE BARRIER)
GL05 --- 6mm+12mm AIR GAP+8mm THK. I.G.U.

A	09/12/2020	REVISION SUBJECT TO ARCH.COMMENT	Ivan
NO.	DATE	REVISED	BY

JOB NO. : J-852

PROJECT :
PROPOSED RESIDENTIAL DEVELOPMENT
AT 139 - 147 ARGYLE STREET,
NKIL 6005, 6035 R.P., 6036 R.P.,
6037 R.P. & 6038 R.P.

TITLE :
SCHEDULE FOR Plenum Box
At IN-SITU ALUM. WINDOW(T2-1-21F)

DATE : 05-FEB-20 SCALE : 1:100

DRAWN BY : MN CHECKED BY : DW

美特鋁質有限公司
MIDI ALUMINIUM FABRICATOR LTD.
Units 6-8, Sunray Industrial Centre, 1/F
610 Cha Kwo Ling Road, Kowloon
Tel:23489211-4 Fax:(852)2727666

DWG NO. : J852-SD-PB-4204 REV. : A

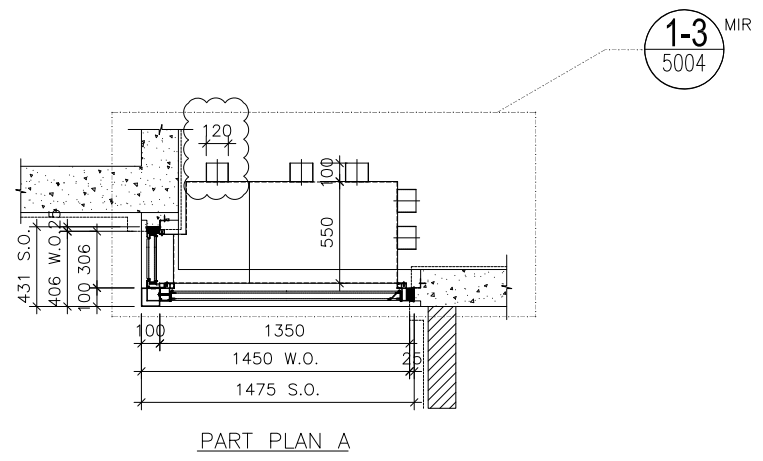
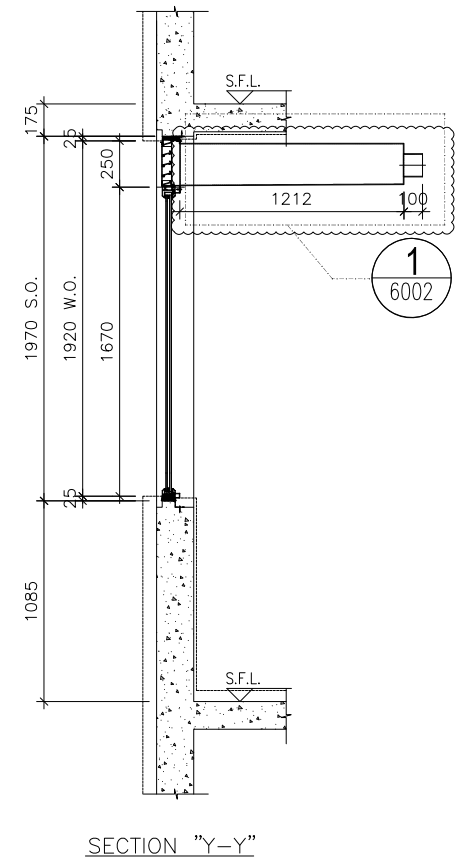
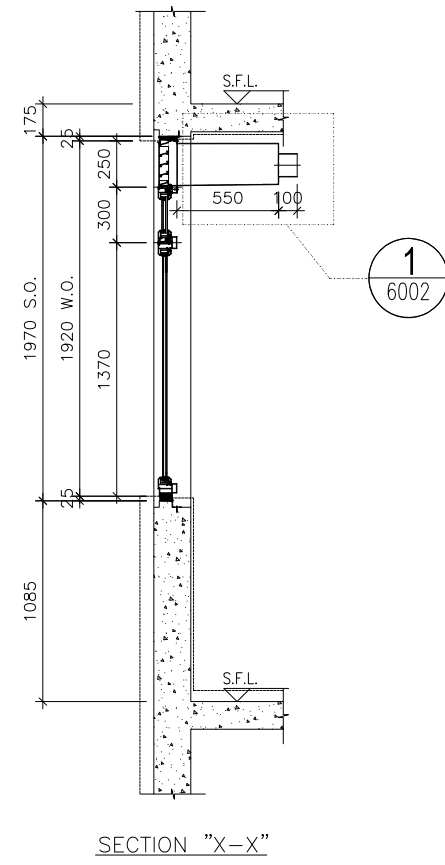
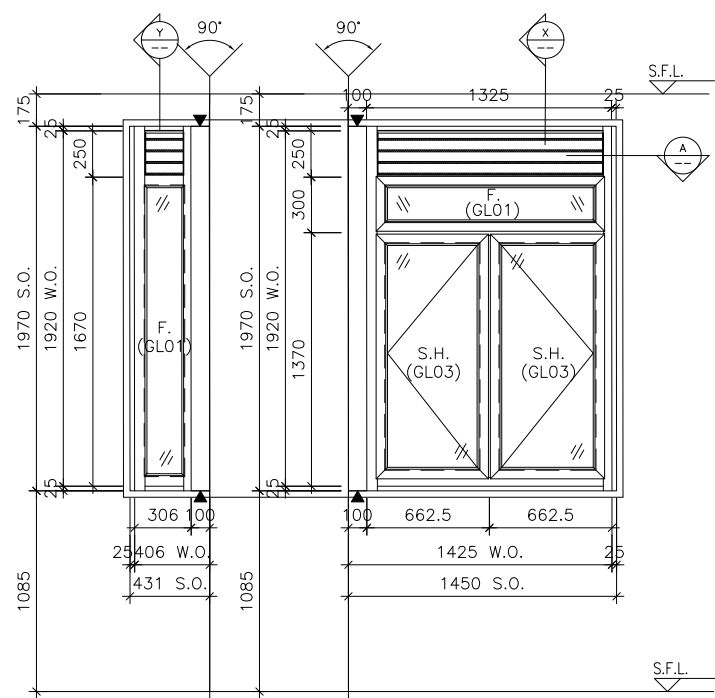

ELEVATION

WINDOW MARK



LOCATION	1/F~21/F KIT. AT TOWER 2 FLAT B
SECTION	50mm ALUM. SECTION
GLAZING	GL01, GL03
QUANTITY	18
REMARKS	

B.D. REF :

CLIENT :

ARCHITECT :
AGC DESIGN LTD
 10/F, 102, Queen Mary, 225, Hyslop Road, North Point, Hong Kong
 Tel: (852) 2511 1111, Fax: (852) 2511 1112, Email: agc@agc.com.hk

MAIN CONTRACTOR :
Gammon

STRUCTURAL ENGINEER :
ARUP

FACADE CONSULTANT:
MEINHARDT

NOTE :

- ALL DIMENSIONS ARE IN mm.
- ALL ELEVATIONS ARE VIEWED FROM OUTSIDE.
- ALL DIMENSIONS TO BE VERIFIED ON SITE BEFORE FABRICATION.

LEGEND :

x1 — DETAIL MARK NO.
 x001 — REFER SHEET NO.

- F.F.L. — FINISHED FLOOR LEVEL
- S.F.L. — STRUCTURAL FLOOR LEVEL
- (R) — REVERSED DETAIL
- (A) — FIXING LOCATION
- (Δ) — FIXING LUG LOCATION
- GLASS LEGEND
 GL01 — 8mm+12mm AIR GAP+10mm THK. I.G.U.
 GL01a — 8mm+9mm AIR GAP+10mm THK. I.G.U.
 GL03 — 6mm+12mm AIR GAP+6mm THK. I.G.U.
 GL04 — 10mm THK. TEMPERED GLASS (PROTECTIVE BARRIER)
 GL05 — 6mm+12mm AIR GAP+8mm THK. I.G.U.

NO.	DATE	REVISION	BY
A	09/12/2020	REVISION SUBJECT TO ARCH.COMMENT	lvart

JOB NO. : J-852

PROJECT :
 PROPOSED RESIDENTIAL DEVELOPMENT
 AT 139 - 147 ARGYLE STREET,
 NKIL 6005, 6035 R.P., 6036 R.P.,
 6037 R.P. & 6038 R.P.

TITLE :
 SCHEDULE FOR Plenum Box
 At IN-SITU ALUM. WINDOW(T2-1-21F)

DATE : 05-FEB-20 SCALE : 1:100

DRAWN BY : MN CHECKED BY : DW

美特鋁質有限公司
MIDI ALUMINIUM FABRICATOR LTD.
 Units 6-8, Sunray Industrial Centre, 1/F
 610 Cha Kwo Ling Road, Kowloon
 Tel:23489211-4 Fax:(852)27727666

DWG NO. : J852-SD-PB-4205 REV. : A

ELEVATION

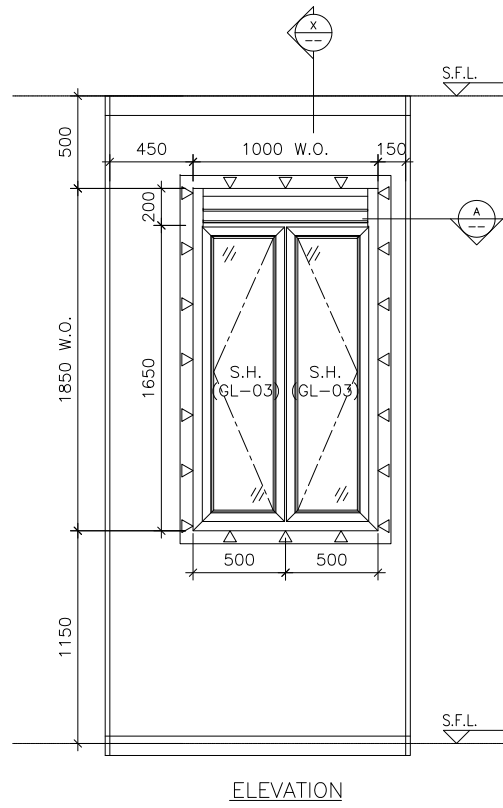

ELEVATION

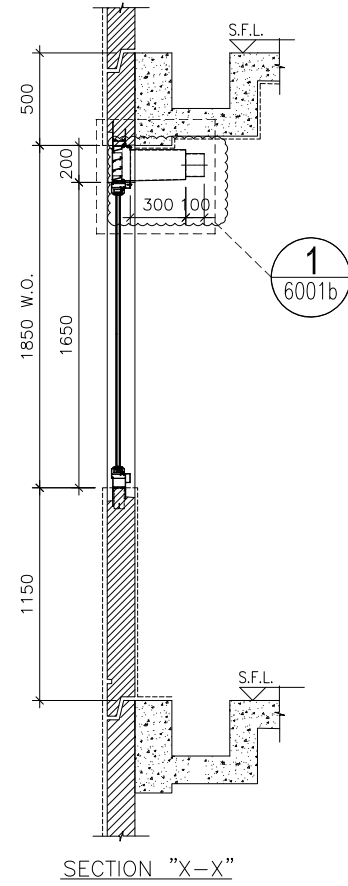

SECTION "X-X"

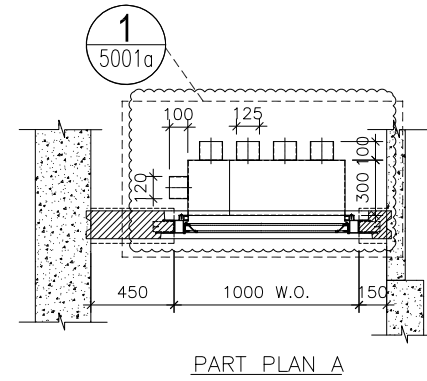

PART PLAN A

WINDOW MARK



LOCATION 22/F KIT. AT TOWER 2 FLAT C

SECTION 70mm ALUM. SECTION

GLAZING GL-03

QUANTITY 1

REMARKS FACADE (PF-28)

B.D. REF :

CLIENT :

ARCHITECT :

AGC
DESIGN LTD

MAIN CONTRACTOR :

Gammon

STRUCTURAL ENGINEER :

ARUP

FACADE CONSULTANT:

MEINHARDT

NOTE :

1. ALL DIMENSIONS ARE IN mm.
2. ALL ELEVATIONS ARE VIEWED FROM OUTSIDE.
3. ALL DIMENSIONS TO BE VERIFIED ON SITE BEFORE FABRICATION.

LEGEND :

- (x1) --- DETAIL MARK NO.
- (x001) --- REFER SHEET NO.

1. F.F.L. --- FINISHED FLOOR LEVEL
2. S.F.L. --- STRUCTURAL FLOOR LEVEL
3. (R) --- REVERSED DETAIL
4. ▲ --- FIXING LOCATION
5. △ --- FIXING LUG LOCATION

6. GLASS LEGEND

- GL01 -- 8mm+12mm AIR GAP+10mm THK. I.G.U.
- GL01a -- 8mm+9mm AIR GAP+10mm THK. I.G.U.
- GL03 -- 6mm+12mm AIR GAP+6mm THK. I.G.U.
- GL04 -- 10mm THK. TEMPERED GLASS (PROTECTIVE BARRIER)
- GL05 -- 6mm+12mm AIR GAP+8mm THK. I.G.U.

NO.	DATE	REVISION	BY
A	09/12/2020	REVISION SUBJECT TO ARCH.COMMENT	Ivan

JOB NO. : J-852

PROJECT :
PROPOSED RESIDENTIAL DEVELOPMENT
AT 139 - 147 ARGYLE STREET,
NKIL 6005, 6035 R.P., 6036 R.P.,
6037 R.P. & 6038 R.P.

TITLE :
SCHEDULE FOR Plenum Box
AT TOWER 2 (22F)

DATE : 05-Dec-19

SCALE : 1:40

DRAWN BY : MN

CHECKED BY : DW

美特鋁質有限公司
MIDI ALUMINIUM FABRICATOR LTD.
Units 6-8, Sunray Industrial Centre, 1/F
610 Cha Kwo Ling Road, Kowloon
Tel:23489211-4 Fax:(852)2727666

DWG NO. : J852-SD-PB-4206

REV. : A

B.D. REF :

CLIENT :

ARCHITECT :
AGC DESIGN LTD
AGC DESIGN LTD
 100, 10/F, D'Almeida Place, 255, King's Road, North Point, Hong Kong
 Tel: (852) 27797882, Fax: (852) 27797823, Email: agc@agc.com.hk

MAIN CONTRACTOR :
Gammon

STRUCTURAL ENGINEER :
ARUP

FACADE CONSULTANT:
MEINHARDT

NOTE :
 1. ALL DIMENSIONS ARE IN mm.
 2. ALL ELEVATIONS ARE VIEWED FROM OUTSIDE.
 3. ALL DIMENSIONS TO BE VERIFIED ON SITE BEFORE FABRICATION.

LEGEND :
 X1 --- DETAIL MARK NO.
 X001 --- REFER SHEET NO.
 1. F.F.L. --- FINISHED FLOOR LEVEL
 2. S.F.L. --- STRUCTURAL FLOOR LEVEL
 3. (R) --- REVERSED DETAIL
 4. ▲ --- FIXING LOCATION
 5. △ --- FIXING LUG LOCATION
 6. GLASS LEGEND
 GL01 --- 8mm+12mm AIR GAP+10mm THK. I.G.U.
 GL01a --- 8mm+9mm AIR GAP+10mm THK. I.G.U.
 GL03 --- 6mm+12mm AIR GAP+6mm THK. I.G.U.
 GL04 --- 10mm THK. TEMPERED GLASS (PROTECTIVE BARRIER)
 GL05 --- 6mm+12mm AIR GAP+8mm THK. I.G.U.

NO.	DATE	REVISION SUBJECT TO ARCH.COMMENT	REVISED	BY
A	07/11/2020	REVISION SUBJECT TO ARCH.COMMENT		Ivan

JOB NO. : J-852
 PROJECT : PROPOSED RESIDENTIAL DEVELOPMENT AT 139 - 147 ARGYLE STREET, NKIL 6005, 6035 R.P., 6036 R.P., 6037 R.P. & 6038 R.P.
 TITLE : SCHEDULE FOR Plenum Box AT TOWER 2 (22F)

DATE : 05-Dec-19 SCALE : 1:40
 DRAWN BY : MN CHECKED BY : DW

美特鋁質有限公司
MIDI ALUMINIUM FABRICATOR LTD.
 Units 6-8, Sunray Industrial Centre, 1/F
 610 Cha Kwo Ling Road, Kowloon
 Tel:23489211-4 Fax:(852)27727666
 DWG NO. : J852-SD-PB-4207 REV. : A

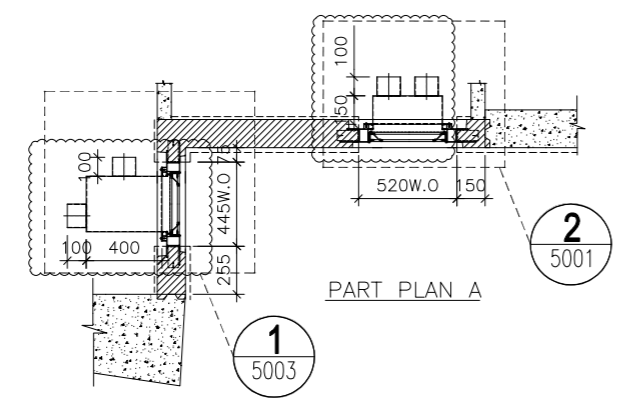
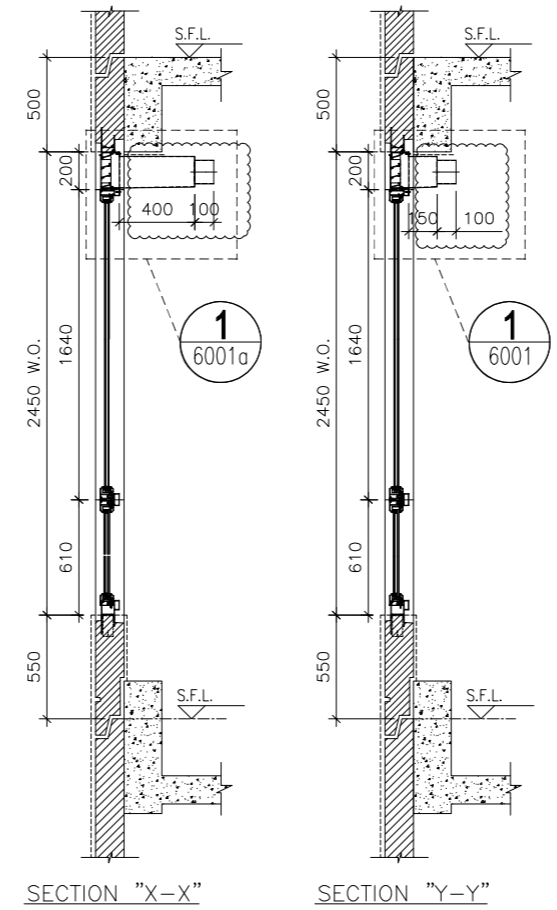
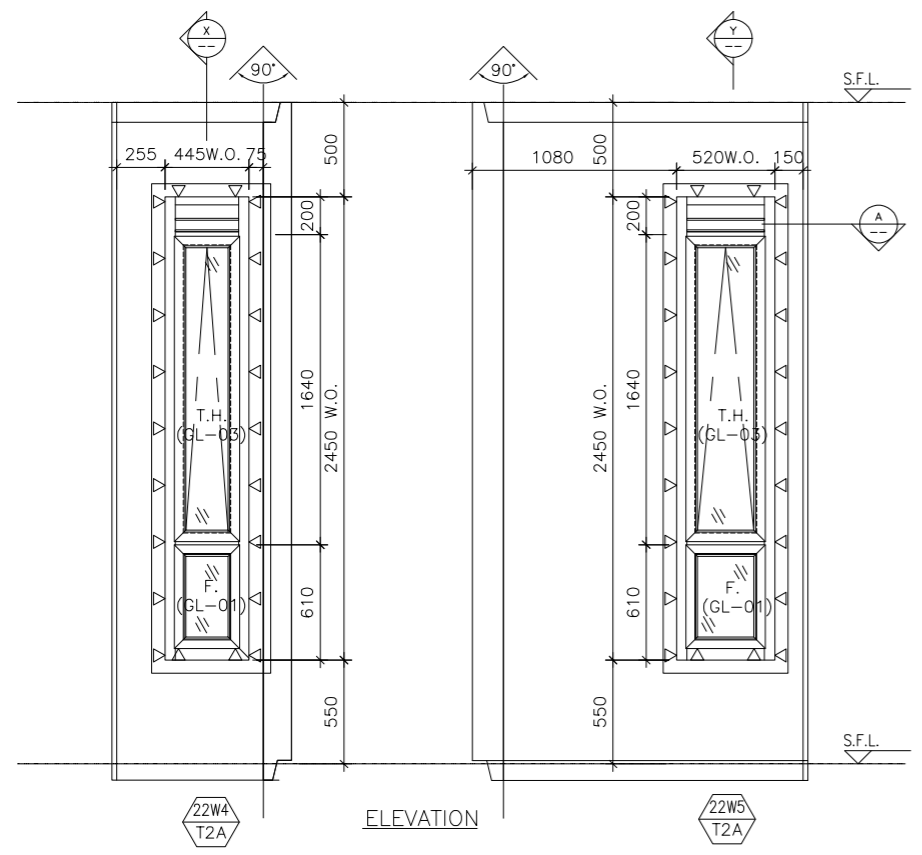

ELEVATION

WINDOW MARK	22W4 / 22W5 T2A / T2A
LOCATION	22/F M.B. & EN.B. AT TOWER 2 FLAT A
SECTION	70mm ALUM. SECTION
GLAZING	GL-01, (GL-03)
QUANTITY	1
REMARKS	FACADE (PF-35)

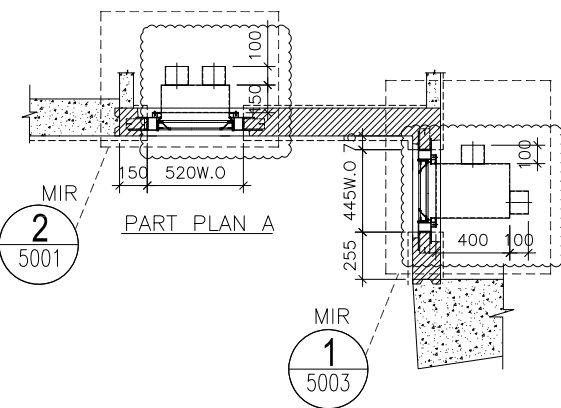
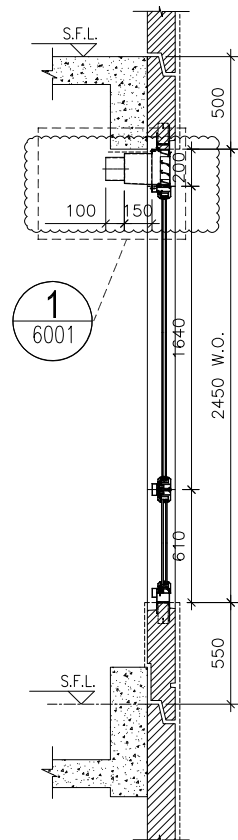
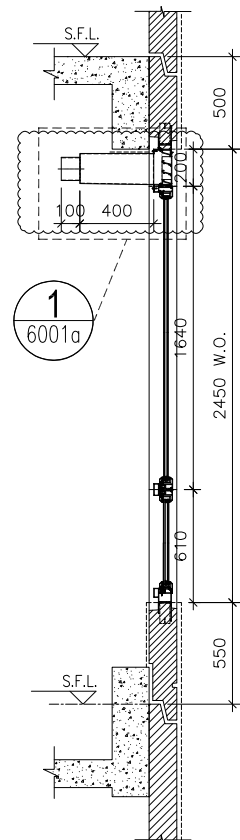
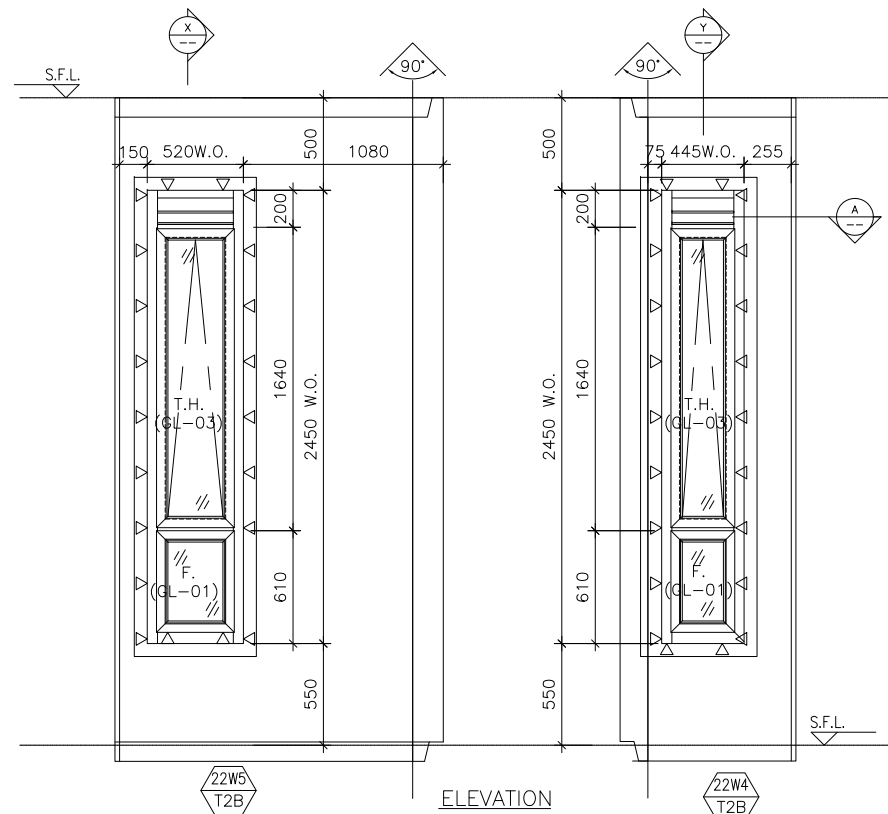

ELEVATION

SECTION "Y-Y"

SECTION "X-X"

B.D. REF :

CLIENT :

ARCHITECT :
AGC DESIGN LTD
 10/F, 100, Queen Mary, 251, Hong Kong
 Tel: (852)2111188 Fax: (852)2111152 Email: agc@agc.com.hk

MAIN CONTRACTOR :
Gammon

STRUCTURAL ENGINEER :
ARUP

FACADE CONSULTANT:
MEINHARDT

NOTE :
 1. ALL DIMENSIONS ARE IN mm.
 2. ALL ELEVATIONS ARE VIEWED FROM OUTSIDE.
 3. ALL DIMENSIONS TO BE VERIFIED ON SITE BEFORE FABRICATION.

LEGEND :
 (X1) --- DETAIL MARK NO.
 (X001) --- REFER SHEET NO.
 1. F.F.L. --- FINISHED FLOOR LEVEL
 2. S.F.L. --- STRUCTURAL FLOOR LEVEL
 3. (R) --- REVERSED DETAIL
 4. ▲ --- FIXING LOCATION
 5. △ --- FIXING LUG LOCATION
 6. GLASS LEGEND
 GL01 --- 8mm+12mm AIR GAP+10mm THK. I.G.U.
 GL01a --- 8mm+9mm AIR GAP+10mm THK. I.G.U.
 GL03 --- 6mm+12mm AIR GAP+6mm THK. I.G.U.
 GL04 --- 10mm THK. TEMPERED GLASS (PROTECTIVE BARRIER)
 GL05 --- 6mm+12mm AIR GAP+8mm THK. I.G.U.

NO.	DATE	REVISION	BY
A	07/11/2020	REVISION SUBJECT TO ARCH.COMMENT	lvart

JOB NO. : J-852
 PROJECT :
 PROPOSED RESIDENTIAL DEVELOPMENT
 AT 139 - 147 ARGYLE STREET,
 NKIL 6005, 6035 R.P., 6036 R.P.,
 6037 R.P. & 6038 R.P.

TITLE :
 SCHEDULE FOR Plenum Box
 AT TOWER 2 (22F)

DATE : 05-Dec-19 SCALE : 1:40
 DRAWN BY : MN CHECKED BY : DW

美特鋁質有限公司
MIDI ALUMINIUM FABRICATOR LTD.
 Units 6-8, Sunray Industrial Centre, 1/F
 610 Cha Kwo Ling Road, Kowloon
 Tel:23489211-4 Fax:(852)2727666

DWG NO. : J852-SD-PB-4208 REV. : A

WINDOW MARK	22W5 / 22W4 T2B / T2B
LOCATION	22/F M.B. & EN.B. AT TOWER 2 FLAT B
SECTION	70mm ALUM. SECTION
GLAZING	GL-01, GL-03
QUANTITY	1
REMARKS	FACADE (PF-36)

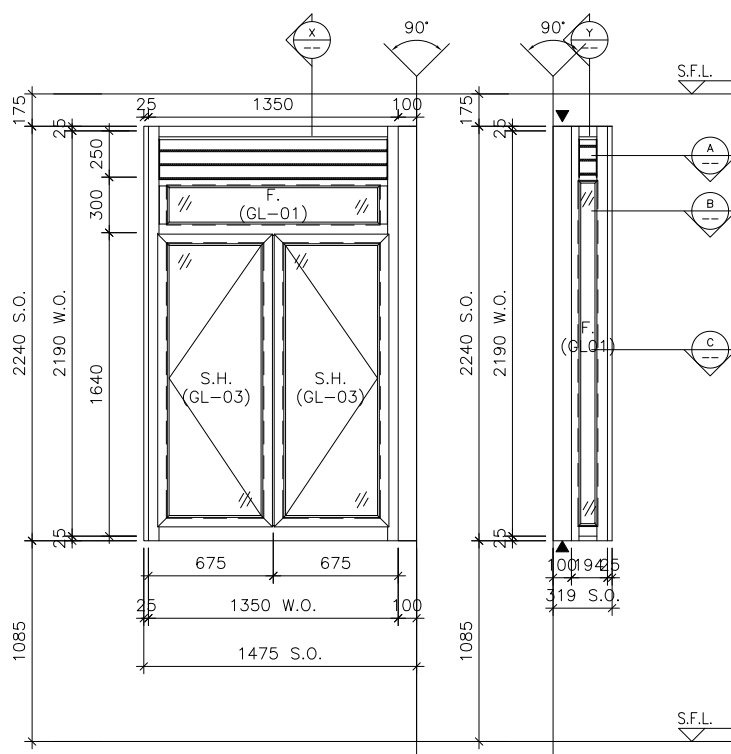

ELEVATION

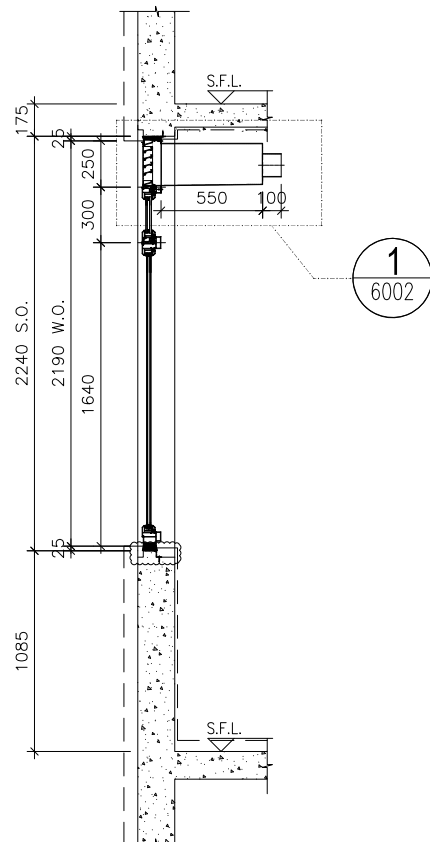

SECTION "X-X"

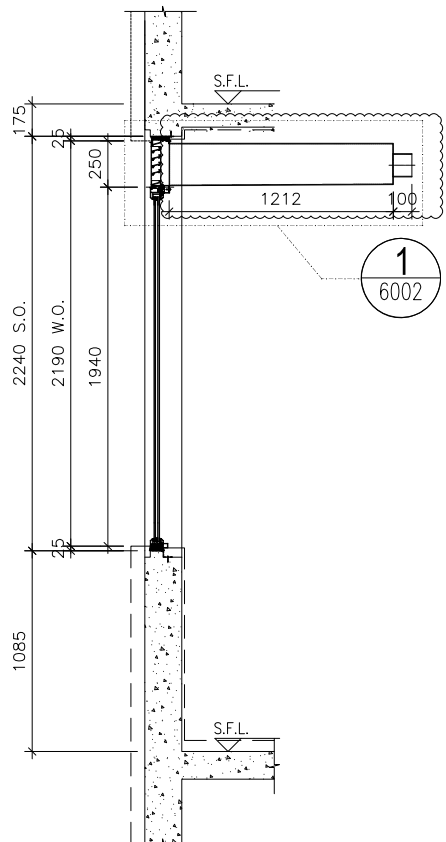

SECTION "Y-Y"

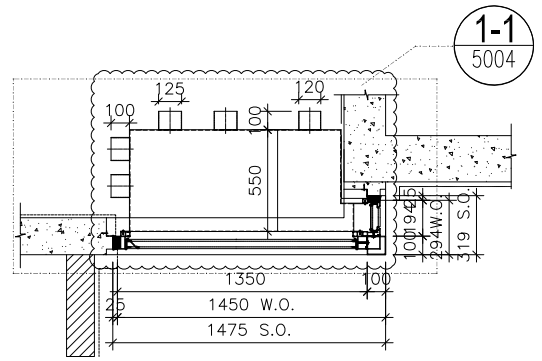

PART PLAN A

ELEVATION

B.D. REF :

CLIENT :

ARCHITECT :
AGC DESIGN LTD
 100, 101, 102, 103, 104, 105, 106, 107, 108, 109, 110, 111, 112, 113, 114, 115, 116, 117, 118, 119, 120, 121, 122, 123, 124, 125, 126, 127, 128, 129, 130, 131, 132, 133, 134, 135, 136, 137, 138, 139, 140, 141, 142, 143, 144, 145, 146, 147, 148, 149, 150, 151, 152, 153, 154, 155, 156, 157, 158, 159, 160, 161, 162, 163, 164, 165, 166, 167, 168, 169, 170, 171, 172, 173, 174, 175, 176, 177, 178, 179, 180, 181, 182, 183, 184, 185, 186, 187, 188, 189, 190, 191, 192, 193, 194, 195, 196, 197, 198, 199, 200, 201, 202, 203, 204, 205, 206, 207, 208, 209, 210, 211, 212, 213, 214, 215, 216, 217, 218, 219, 220, 221, 222, 223, 224, 225, 226, 227, 228, 229, 230, 231, 232, 233, 234, 235, 236, 237, 238, 239, 240, 241, 242, 243, 244, 245, 246, 247, 248, 249, 250, 251, 252, 253, 254, 255, 256, 257, 258, 259, 260, 261, 262, 263, 264, 265, 266, 267, 268, 269, 270, 271, 272, 273, 274, 275, 276, 277, 278, 279, 280, 281, 282, 283, 284, 285, 286, 287, 288, 289, 290, 291, 292, 293, 294, 295, 296, 297, 298, 299, 300, 301, 302, 303, 304, 305, 306, 307, 308, 309, 310, 311, 312, 313, 314, 315, 316, 317, 318, 319, 320, 321, 322, 323, 324, 325, 326, 327, 328, 329, 330, 331, 332, 333, 334, 335, 336, 337, 338, 339, 340, 341, 342, 343, 344, 345, 346, 347, 348, 349, 350, 351, 352, 353, 354, 355, 356, 357, 358, 359, 360, 361, 362, 363, 364, 365, 366, 367, 368, 369, 370, 371, 372, 373, 374, 375, 376, 377, 378, 379, 380, 381, 382, 383, 384, 385, 386, 387, 388, 389, 390, 391, 392, 393, 394, 395, 396, 397, 398, 399, 400, 401, 402, 403, 404, 405, 406, 407, 408, 409, 410, 411, 412, 413, 414, 415, 416, 417, 418, 419, 420, 421, 422, 423, 424, 425, 426, 427, 428, 429, 430, 431, 432, 433, 434, 435, 436, 437, 438, 439, 440, 441, 442, 443, 444, 445, 446, 447, 448, 449, 450, 451, 452, 453, 454, 455, 456, 457, 458, 459, 460, 461, 462, 463, 464, 465, 466, 467, 468, 469, 470, 471, 472, 473, 474, 475, 476, 477, 478, 479, 480, 481, 482, 483, 484, 485, 486, 487, 488, 489, 490, 491, 492, 493, 494, 495, 496, 497, 498, 499, 500, 501, 502, 503, 504, 505, 506, 507, 508, 509, 510, 511, 512, 513, 514, 515, 516, 517, 518, 519, 520, 521, 522, 523, 524, 525, 526, 527, 528, 529, 530, 531, 532, 533, 534, 535, 536, 537, 538, 539, 540, 541, 542, 543, 544, 545, 546, 547, 548, 549, 550, 551, 552, 553, 554, 555, 556, 557, 558, 559, 560, 561, 562, 563, 564, 565, 566, 567, 568, 569, 570, 571, 572, 573, 574, 575, 576, 577, 578, 579, 580, 581, 582, 583, 584, 585, 586, 587, 588, 589, 590, 591, 592, 593, 594, 595, 596, 597, 598, 599, 600, 601, 602, 603, 604, 605, 606, 607, 608, 609, 610, 611, 612, 613, 614, 615, 616, 617, 618, 619, 620, 621, 622, 623, 624, 625, 626, 627, 628, 629, 630, 631, 632, 633, 634, 635, 636, 637, 638, 639, 640, 641, 642, 643, 644, 645, 646, 647, 648, 649, 650, 651, 652, 653, 654, 655, 656, 657, 658, 659, 660, 661, 662, 663, 664, 665, 666, 667, 668, 669, 670, 671, 672, 673, 674, 675, 676, 677, 678, 679, 680, 681, 682, 683, 684, 685, 686, 687, 688, 689, 690, 691, 692, 693, 694, 695, 696, 697, 698, 699, 700, 701, 702, 703, 704, 705, 706, 707, 708, 709, 710, 711, 712, 713, 714, 715, 716, 717, 718, 719, 720, 721, 722, 723, 724, 725, 726, 727, 728, 729, 730, 731, 732, 733, 734, 735, 736, 737, 738, 739, 740, 741, 742, 743, 744, 745, 746, 747, 748, 749, 750, 751, 752, 753, 754, 755, 756, 757, 758, 759, 760, 761, 762, 763, 764, 765, 766, 767, 768, 769, 770, 771, 772, 773, 774, 775, 776, 777, 778, 779, 780, 781, 782, 783, 784, 785, 786, 787, 788, 789, 790, 791, 792, 793, 794, 795, 796, 797, 798, 799, 800, 801, 802, 803, 804, 805, 806, 807, 808, 809, 810, 811, 812, 813, 814, 815, 816, 817, 818, 819, 820, 821, 822, 823, 824, 825, 826, 827, 828, 829, 830, 831, 832, 833, 834, 835, 836, 837, 838, 839, 840, 841, 842, 843, 844, 845, 846, 847, 848, 849, 850, 851, 852, 853, 854, 855, 856, 857, 858, 859, 860, 861, 862, 863, 864, 865, 866, 867, 868, 869, 870, 871, 872, 873, 874, 875, 876, 877, 878, 879, 880, 881, 882, 883, 884, 885, 886, 887, 888, 889, 890, 891, 892, 893, 894, 895, 896, 897, 898, 899, 900, 901, 902, 903, 904, 905, 906, 907, 908, 909, 910, 911, 912, 913, 914, 915, 916, 917, 918, 919, 920, 921, 922, 923, 924, 925, 926, 927, 928, 929, 930, 931, 932, 933, 934, 935, 936, 937, 938, 939, 940, 941, 942, 943, 944, 945, 946, 947, 948, 949, 950, 951, 952, 953, 954, 955, 956, 957, 958, 959, 960, 961, 962, 963, 964, 965, 966, 967, 968, 969, 970, 971, 972, 973, 974, 975, 976, 977, 978, 979, 980, 981, 982, 983, 984, 985, 986, 987, 988, 989, 990, 991, 992, 993, 994, 995, 996, 997, 998, 999, 1000

MAIN CONTRACTOR :
Gammon

STRUCTURAL ENGINEER :
ARUP

FACADE CONSULTANT:
MEINHARDT

NOTE :
 1. ALL DIMENSIONS ARE IN mm.
 2. ALL ELEVATIONS ARE VIEWED FROM OUTSIDE.
 3. ALL DIMENSIONS TO BE VERIFIED ON SITE BEFORE FABRICATION.

LEGEND :
 (X1) --- DETAIL MARK NO.
 (X001) --- REFER SHEET NO.
 1. F.F.L. --- FINISHED FLOOR LEVEL
 2. S.F.L. --- STRUCTURAL FLOOR LEVEL
 3. (R) --- REVERSED DETAIL

NO.	DATE	REVISION	BY
A	09/12/2020	REVISION SUBJECT TO ARCH.COMMENT	Ivan

JOB NO. : J-852
 PROJECT :
 PROPOSED RESIDENTIAL DEVELOPMENT
 AT 139 - 147 ARGYLE STREET,
 NKIL 6005, 6035 R.P., 6036 R.P.,
 6037 R.P. & 6038 R.P.

TITLE :
 SCHEDULE FOR Plenum Box
 At IN-SITU ALUM. WINDOW(22F)

DATE : 05-FEB-20 SCALE : 1:100
 DRAWN BY : MN CHECKED BY : DW

美特鋁質有限公司
MIDI ALUMINIUM FABRICATOR LTD.
 Units 6-8, Sunray Industrial Centre, 1/F
 610 Cha Kwo Ling Road, Kowloon
 Tel:23489211-4 Fax:(852)2727666

DWG NO. : J852-SD-PB-4209 REV. : A

WINDOW MARK	
LOCATION	22/F KIT. AT TOWER 2 FLAT A
SECTION	50mm ALUM. SECTION
GLAZING	GL-01, GL-03
QUANTITY	1
REMARKS	

ELEVATION

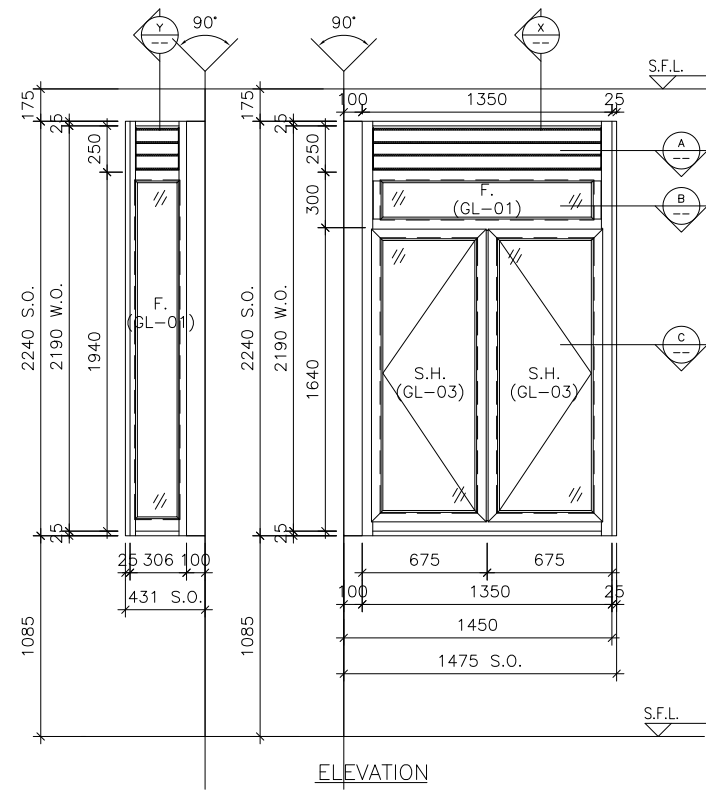

ELEVATION

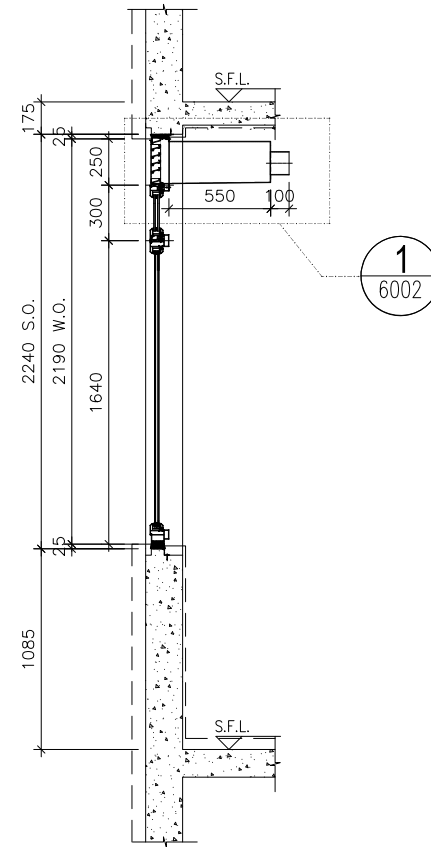

SECTION "X-X"

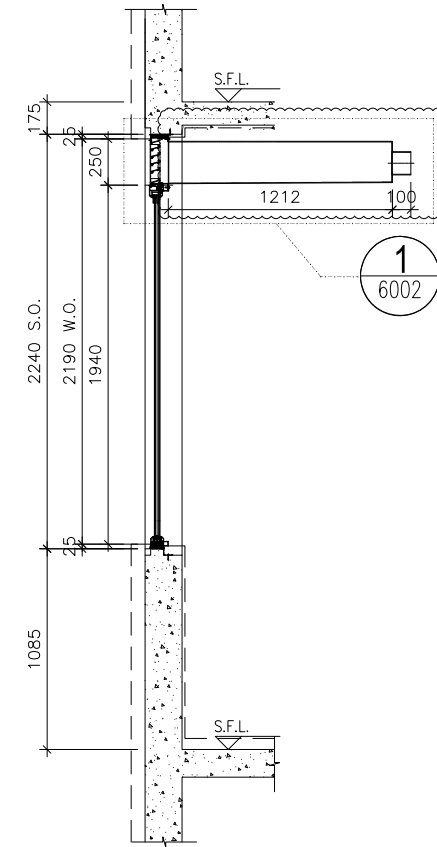

SECTION "Y-Y"

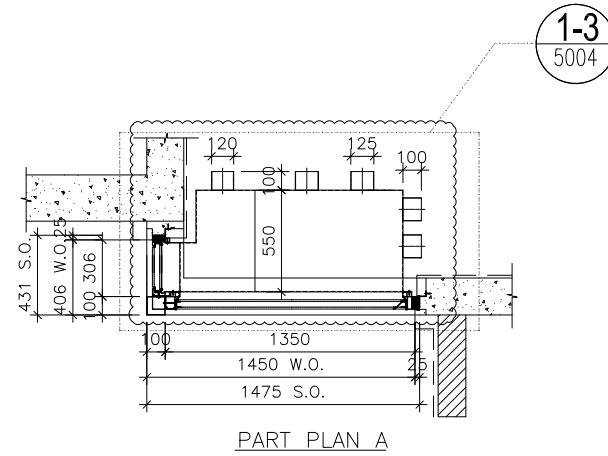

PART PLAN A

WINDOW MARK



LOCATION 22/F KIT. AT TOWER 2 FLAT B

SECTION 50mm ALUM. SECTION

GLAZING GL-01, GL-03

QUANTITY 1

REMARKS

B.D. REF :

CLIENT :

ARCHITECT :
AGC DESIGN LTD
 101, 102, 103, 104, 105, 106, 107, 108, 109, 110, 111, 112, 113, 114, 115, 116, 117, 118, 119, 120, 121, 122, 123, 124, 125, 126, 127, 128, 129, 130, 131, 132, 133, 134, 135, 136, 137, 138, 139, 140, 141, 142, 143, 144, 145, 146, 147, 148, 149, 150, 151, 152, 153, 154, 155, 156, 157, 158, 159, 160, 161, 162, 163, 164, 165, 166, 167, 168, 169, 170, 171, 172, 173, 174, 175, 176, 177, 178, 179, 180, 181, 182, 183, 184, 185, 186, 187, 188, 189, 190, 191, 192, 193, 194, 195, 196, 197, 198, 199, 200, 201, 202, 203, 204, 205, 206, 207, 208, 209, 210, 211, 212, 213, 214, 215, 216, 217, 218, 219, 220, 221, 222, 223, 224, 225, 226, 227, 228, 229, 230, 231, 232, 233, 234, 235, 236, 237, 238, 239, 240, 241, 242, 243, 244, 245, 246, 247, 248, 249, 250, 251, 252, 253, 254, 255, 256, 257, 258, 259, 260, 261, 262, 263, 264, 265, 266, 267, 268, 269, 270, 271, 272, 273, 274, 275, 276, 277, 278, 279, 280, 281, 282, 283, 284, 285, 286, 287, 288, 289, 290, 291, 292, 293, 294, 295, 296, 297, 298, 299, 300, 301, 302, 303, 304, 305, 306, 307, 308, 309, 310, 311, 312, 313, 314, 315, 316, 317, 318, 319, 320, 321, 322, 323, 324, 325, 326, 327, 328, 329, 330, 331, 332, 333, 334, 335, 336, 337, 338, 339, 340, 341, 342, 343, 344, 345, 346, 347, 348, 349, 350, 351, 352, 353, 354, 355, 356, 357, 358, 359, 360, 361, 362, 363, 364, 365, 366, 367, 368, 369, 370, 371, 372, 373, 374, 375, 376, 377, 378, 379, 380, 381, 382, 383, 384, 385, 386, 387, 388, 389, 390, 391, 392, 393, 394, 395, 396, 397, 398, 399, 400, 401, 402, 403, 404, 405, 406, 407, 408, 409, 410, 411, 412, 413, 414, 415, 416, 417, 418, 419, 420, 421, 422, 423, 424, 425, 426, 427, 428, 429, 430, 431, 432, 433, 434, 435, 436, 437, 438, 439, 440, 441, 442, 443, 444, 445, 446, 447, 448, 449, 450, 451, 452, 453, 454, 455, 456, 457, 458, 459, 460, 461, 462, 463, 464, 465, 466, 467, 468, 469, 470, 471, 472, 473, 474, 475, 476, 477, 478, 479, 480, 481, 482, 483, 484, 485, 486, 487, 488, 489, 490, 491, 492, 493, 494, 495, 496, 497, 498, 499, 500, 501, 502, 503, 504, 505, 506, 507, 508, 509, 510, 511, 512, 513, 514, 515, 516, 517, 518, 519, 520, 521, 522, 523, 524, 525, 526, 527, 528, 529, 530, 531, 532, 533, 534, 535, 536, 537, 538, 539, 540, 541, 542, 543, 544, 545, 546, 547, 548, 549, 550, 551, 552, 553, 554, 555, 556, 557, 558, 559, 560, 561, 562, 563, 564, 565, 566, 567, 568, 569, 570, 571, 572, 573, 574, 575, 576, 577, 578, 579, 580, 581, 582, 583, 584, 585, 586, 587, 588, 589, 590, 591, 592, 593, 594, 595, 596, 597, 598, 599, 600, 601, 602, 603, 604, 605, 606, 607, 608, 609, 610, 611, 612, 613, 614, 615, 616, 617, 618, 619, 620, 621, 622, 623, 624, 625, 626, 627, 628, 629, 630, 631, 632, 633, 634, 635, 636, 637, 638, 639, 640, 641, 642, 643, 644, 645, 646, 647, 648, 649, 650, 651, 652, 653, 654, 655, 656, 657, 658, 659, 660, 661, 662, 663, 664, 665, 666, 667, 668, 669, 670, 671, 672, 673, 674, 675, 676, 677, 678, 679, 680, 681, 682, 683, 684, 685, 686, 687, 688, 689, 690, 691, 692, 693, 694, 695, 696, 697, 698, 699, 700, 701, 702, 703, 704, 705, 706, 707, 708, 709, 710, 711, 712, 713, 714, 715, 716, 717, 718, 719, 720, 721, 722, 723, 724, 725, 726, 727, 728, 729, 730, 731, 732, 733, 734, 735, 736, 737, 738, 739, 740, 741, 742, 743, 744, 745, 746, 747, 748, 749, 750, 751, 752, 753, 754, 755, 756, 757, 758, 759, 760, 761, 762, 763, 764, 765, 766, 767, 768, 769, 770, 771, 772, 773, 774, 775, 776, 777, 778, 779, 780, 781, 782, 783, 784, 785, 786, 787, 788, 789, 790, 791, 792, 793, 794, 795, 796, 797, 798, 799, 800, 801, 802, 803, 804, 805, 806, 807, 808, 809, 810, 811, 812, 813, 814, 815, 816, 817, 818, 819, 820, 821, 822, 823, 824, 825, 826, 827, 828, 829, 830, 831, 832, 833, 834, 835, 836, 837, 838, 839, 840, 841, 842, 843, 844, 845, 846, 847, 848, 849, 850, 851, 852, 853, 854, 855, 856, 857, 858, 859, 860, 861, 862, 863, 864, 865, 866, 867, 868, 869, 870, 871, 872, 873, 874, 875, 876, 877, 878, 879, 880, 881, 882, 883, 884, 885, 886, 887, 888, 889, 890, 891, 892, 893, 894, 895, 896, 897, 898, 899, 900, 901, 902, 903, 904, 905, 906, 907, 908, 909, 910, 911, 912, 913, 914, 915, 916, 917, 918, 919, 920, 921, 922, 923, 924, 925, 926, 927, 928, 929, 930, 931, 932, 933, 934, 935, 936, 937, 938, 939, 940, 941, 942, 943, 944, 945, 946, 947, 948, 949, 950, 951, 952, 953, 954, 955, 956, 957, 958, 959, 960, 961, 962, 963, 964, 965, 966, 967, 968, 969, 970, 971, 972, 973, 974, 975, 976, 977, 978, 979, 980, 981, 982, 983, 984, 985, 986, 987, 988, 989, 990, 991, 992, 993, 994, 995, 996, 997, 998, 999, 1000

MAIN CONTRACTOR :
Gammon

STRUCTURAL ENGINEER :
ARUP

FACADE CONSULTANT:
MEINHARDT

NOTE :
 1. ALL DIMENSIONS ARE IN mm.
 2. ALL ELEVATIONS ARE VIEWED FROM OUTSIDE.
 3. ALL DIMENSIONS TO BE VERIFIED ON SITE BEFORE FABRICATION.

LEGEND :
 (X1) --- DETAIL MARK NO.
 (X001) --- REFER SHEET NO.

1. F.F.L. --- FINISHED FLOOR LEVEL
 2. S.F.L. --- STRUCTURAL FLOOR LEVEL
 3. (R) --- REVERSED DETAIL

NO.	DATE	REVISION	BY
A	09/12/2020	REVISION SUBJECT TO ARCH.COMMENT	Ivan

JOB NO. : J-852
 PROJECT :
 PROPOSED RESIDENTIAL DEVELOPMENT
 AT 139 - 147 ARGYLE STREET,
 NKIL 6005, 6035 R.P., 6036 R.P.,
 6037 R.P. & 6038 R.P.

TITLE :
 SCHEDULE FOR Plenum Box
 At IN-SITU ALUM. WINDOW(22F)

DATE : 05-FEB-20 SCALE : 1:100

DRAWN BY : MN CHECKED BY : DW

美特鋁質有限公司
MIDI ALUMINIUM FABRICATOR LTD.
 Units 6-8, Sunray Industrial Centre, 1/F
 610 Cha Kwo Ling Road, Kowloon
 Tel:23489211-4 Fax:(852)2727666

DWG NO. : J852-SD-PB-4210 REV. : A

ELEVATION

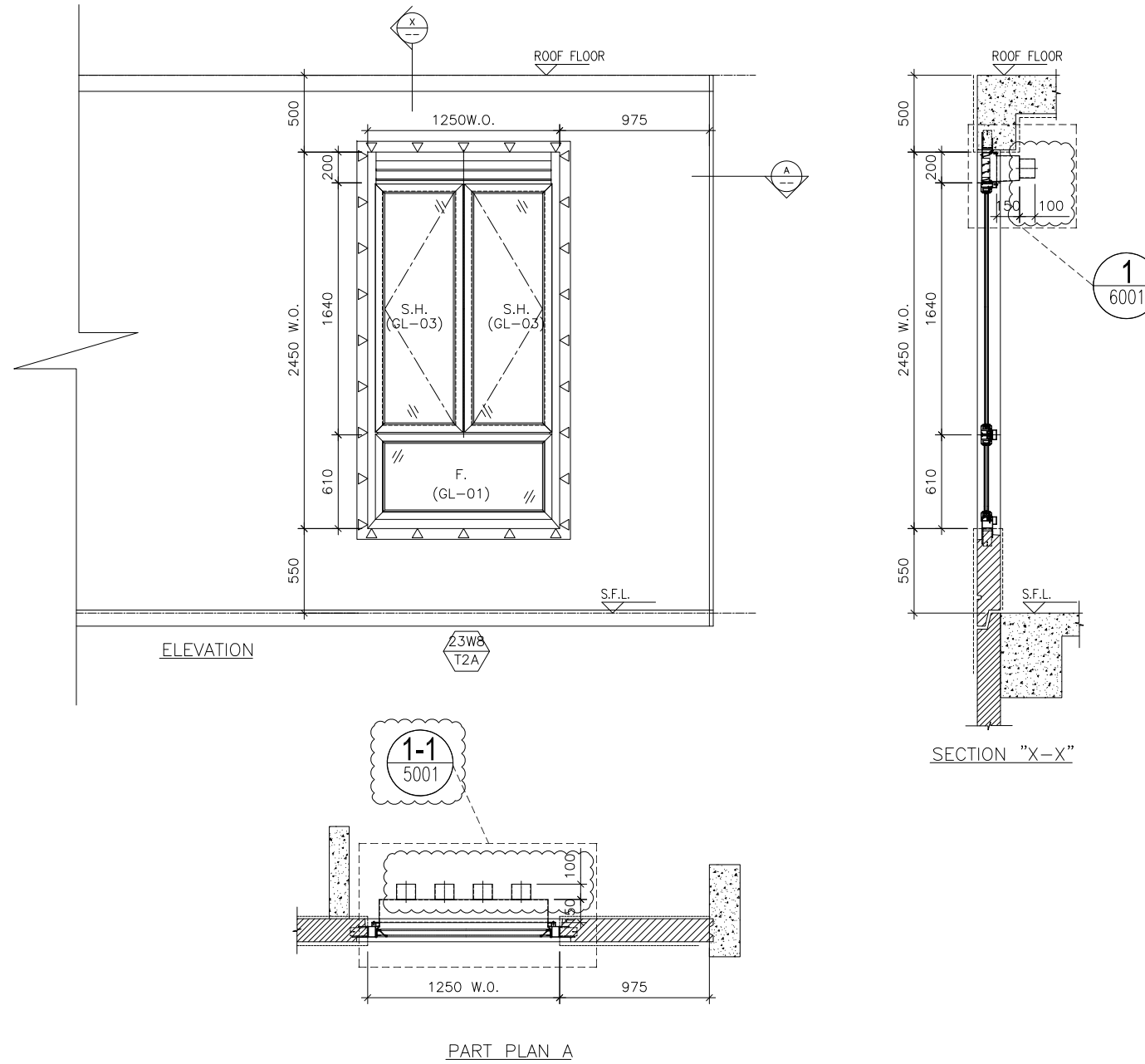

WINDOW MARK



LOCATION 23/F M.EN AT TOWER 2 FLAT A

SECTION 70mm ALUM. SECTION

GLAZING GL-01, GL-03

QUANTITY 1

REMARKS FACADE (PF-20)

B.D. REF :

CLIENT :

ARCHITECT :
AGC DESIGN LTD
 101, 102, 103, 104, 105, 106, 107, 108, 109, 110, 111, 112, 113, 114, 115, 116, 117, 118, 119, 120, 121, 122, 123, 124, 125, 126, 127, 128, 129, 130, 131, 132, 133, 134, 135, 136, 137, 138, 139, 140, 141, 142, 143, 144, 145, 146, 147, 148, 149, 150, 151, 152, 153, 154, 155, 156, 157, 158, 159, 160, 161, 162, 163, 164, 165, 166, 167, 168, 169, 170, 171, 172, 173, 174, 175, 176, 177, 178, 179, 180, 181, 182, 183, 184, 185, 186, 187, 188, 189, 190, 191, 192, 193, 194, 195, 196, 197, 198, 199, 200, 201, 202, 203, 204, 205, 206, 207, 208, 209, 210, 211, 212, 213, 214, 215, 216, 217, 218, 219, 220, 221, 222, 223, 224, 225, 226, 227, 228, 229, 230, 231, 232, 233, 234, 235, 236, 237, 238, 239, 240, 241, 242, 243, 244, 245, 246, 247, 248, 249, 250, 251, 252, 253, 254, 255, 256, 257, 258, 259, 260, 261, 262, 263, 264, 265, 266, 267, 268, 269, 270, 271, 272, 273, 274, 275, 276, 277, 278, 279, 280, 281, 282, 283, 284, 285, 286, 287, 288, 289, 290, 291, 292, 293, 294, 295, 296, 297, 298, 299, 300, 301, 302, 303, 304, 305, 306, 307, 308, 309, 310, 311, 312, 313, 314, 315, 316, 317, 318, 319, 320, 321, 322, 323, 324, 325, 326, 327, 328, 329, 330, 331, 332, 333, 334, 335, 336, 337, 338, 339, 340, 341, 342, 343, 344, 345, 346, 347, 348, 349, 350, 351, 352, 353, 354, 355, 356, 357, 358, 359, 360, 361, 362, 363, 364, 365, 366, 367, 368, 369, 370, 371, 372, 373, 374, 375, 376, 377, 378, 379, 380, 381, 382, 383, 384, 385, 386, 387, 388, 389, 390, 391, 392, 393, 394, 395, 396, 397, 398, 399, 400, 401, 402, 403, 404, 405, 406, 407, 408, 409, 410, 411, 412, 413, 414, 415, 416, 417, 418, 419, 420, 421, 422, 423, 424, 425, 426, 427, 428, 429, 430, 431, 432, 433, 434, 435, 436, 437, 438, 439, 440, 441, 442, 443, 444, 445, 446, 447, 448, 449, 450, 451, 452, 453, 454, 455, 456, 457, 458, 459, 460, 461, 462, 463, 464, 465, 466, 467, 468, 469, 470, 471, 472, 473, 474, 475, 476, 477, 478, 479, 480, 481, 482, 483, 484, 485, 486, 487, 488, 489, 490, 491, 492, 493, 494, 495, 496, 497, 498, 499, 500, 501, 502, 503, 504, 505, 506, 507, 508, 509, 510, 511, 512, 513, 514, 515, 516, 517, 518, 519, 520, 521, 522, 523, 524, 525, 526, 527, 528, 529, 530, 531, 532, 533, 534, 535, 536, 537, 538, 539, 540, 541, 542, 543, 544, 545, 546, 547, 548, 549, 550, 551, 552, 553, 554, 555, 556, 557, 558, 559, 560, 561, 562, 563, 564, 565, 566, 567, 568, 569, 570, 571, 572, 573, 574, 575, 576, 577, 578, 579, 580, 581, 582, 583, 584, 585, 586, 587, 588, 589, 590, 591, 592, 593, 594, 595, 596, 597, 598, 599, 600, 601, 602, 603, 604, 605, 606, 607, 608, 609, 610, 611, 612, 613, 614, 615, 616, 617, 618, 619, 620, 621, 622, 623, 624, 625, 626, 627, 628, 629, 630, 631, 632, 633, 634, 635, 636, 637, 638, 639, 640, 641, 642, 643, 644, 645, 646, 647, 648, 649, 650, 651, 652, 653, 654, 655, 656, 657, 658, 659, 660, 661, 662, 663, 664, 665, 666, 667, 668, 669, 670, 671, 672, 673, 674, 675, 676, 677, 678, 679, 680, 681, 682, 683, 684, 685, 686, 687, 688, 689, 690, 691, 692, 693, 694, 695, 696, 697, 698, 699, 700, 701, 702, 703, 704, 705, 706, 707, 708, 709, 710, 711, 712, 713, 714, 715, 716, 717, 718, 719, 720, 721, 722, 723, 724, 725, 726, 727, 728, 729, 730, 731, 732, 733, 734, 735, 736, 737, 738, 739, 740, 741, 742, 743, 744, 745, 746, 747, 748, 749, 750, 751, 752, 753, 754, 755, 756, 757, 758, 759, 760, 761, 762, 763, 764, 765, 766, 767, 768, 769, 770, 771, 772, 773, 774, 775, 776, 777, 778, 779, 780, 781, 782, 783, 784, 785, 786, 787, 788, 789, 790, 791, 792, 793, 794, 795, 796, 797, 798, 799, 800, 801, 802, 803, 804, 805, 806, 807, 808, 809, 810, 811, 812, 813, 814, 815, 816, 817, 818, 819, 820, 821, 822, 823, 824, 825, 826, 827, 828, 829, 830, 831, 832, 833, 834, 835, 836, 837, 838, 839, 840, 841, 842, 843, 844, 845, 846, 847, 848, 849, 850, 851, 852, 853, 854, 855, 856, 857, 858, 859, 860, 861, 862, 863, 864, 865, 866, 867, 868, 869, 870, 871, 872, 873, 874, 875, 876, 877, 878, 879, 880, 881, 882, 883, 884, 885, 886, 887, 888, 889, 890, 891, 892, 893, 894, 895, 896, 897, 898, 899, 900, 901, 902, 903, 904, 905, 906, 907, 908, 909, 910, 911, 912, 913, 914, 915, 916, 917, 918, 919, 920, 921, 922, 923, 924, 925, 926, 927, 928, 929, 930, 931, 932, 933, 934, 935, 936, 937, 938, 939, 940, 941, 942, 943, 944, 945, 946, 947, 948, 949, 950, 951, 952, 953, 954, 955, 956, 957, 958, 959, 960, 961, 962, 963, 964, 965, 966, 967, 968, 969, 970, 971, 972, 973, 974, 975, 976, 977, 978, 979, 980, 981, 982, 983, 984, 985, 986, 987, 988, 989, 990, 991, 992, 993, 994, 995, 996, 997, 998, 999, 1000

MAIN CONTRACTOR :
Gammon

STRUCTURAL ENGINEER :
ARUP

FACADE CONSULTANT:
MEINHARDT

NOTE :
 1. ALL DIMENSIONS ARE IN mm.
 2. ALL ELEVATIONS ARE VIEWED FROM OUTSIDE.
 3. ALL DIMENSIONS TO BE VERIFIED ON SITE BEFORE FABRICATION.

LEGEND :
 x1 -- DETAIL MARK NO.
 x001 -- REFER SHEET NO.
 1. F.F.L. -- FINISHED FLOOR LEVEL
 2. S.F.L. -- STRUCTURAL FLOOR LEVEL
 3. (R) -- REVERSED DETAIL
 4. ▲ -- FIXING LOCATION
 5. △ -- FIXING LUG LOCATION
 6. GLASS LEGEND
 GL01 -- 8mm+12mm AIR GAP+10mm THK. I.G.U.
 GL01a -- 8mm+12mm AIR GAP+10mm THK. I.G.U.
 GL03 -- 6mm+12mm AIR GAP+6mm THK. I.G.U.
 GL04 -- 10mm THK. TEMPERED GLASS (PROTECTIVE BARRIER)
 GL05 -- 6mm+12mm AIR GAP+8mm THK. I.G.U.

NO.	DATE	REVISION	BY
A	07/11/2020	REVISION SUBJECT TO ARCH.COMMENT	lvav

JOB NO. : J-852
 PROJECT :
 PROPOSED RESIDENTIAL DEVELOPMENT
 AT 139 - 147 ARGYLE STREET,
 NKIL 6005, 6035 R.P., 6036 R.P.,
 6037 R.P. & 6038 R.P.

TITLE :
 SCHEDULE FOR Plenum Box
 AT TOWER 2 (23F)

DATE : 05-Dec-19 SCALE : 1:40

DRAWN BY : MN CHECKED BY : DW

美特鋁質有限公司
MIDI ALUMINIUM FABRICATOR LTD.
 Units 6-8, Sunray Industrial Centre, 1/F
 610 Cha Kwo Ling Road, Kowloon
 Tel:23489211-4 Fax:(852)27727666

DWG NO. : J852-SD-PW-4211 REV. : A

ELEVATION

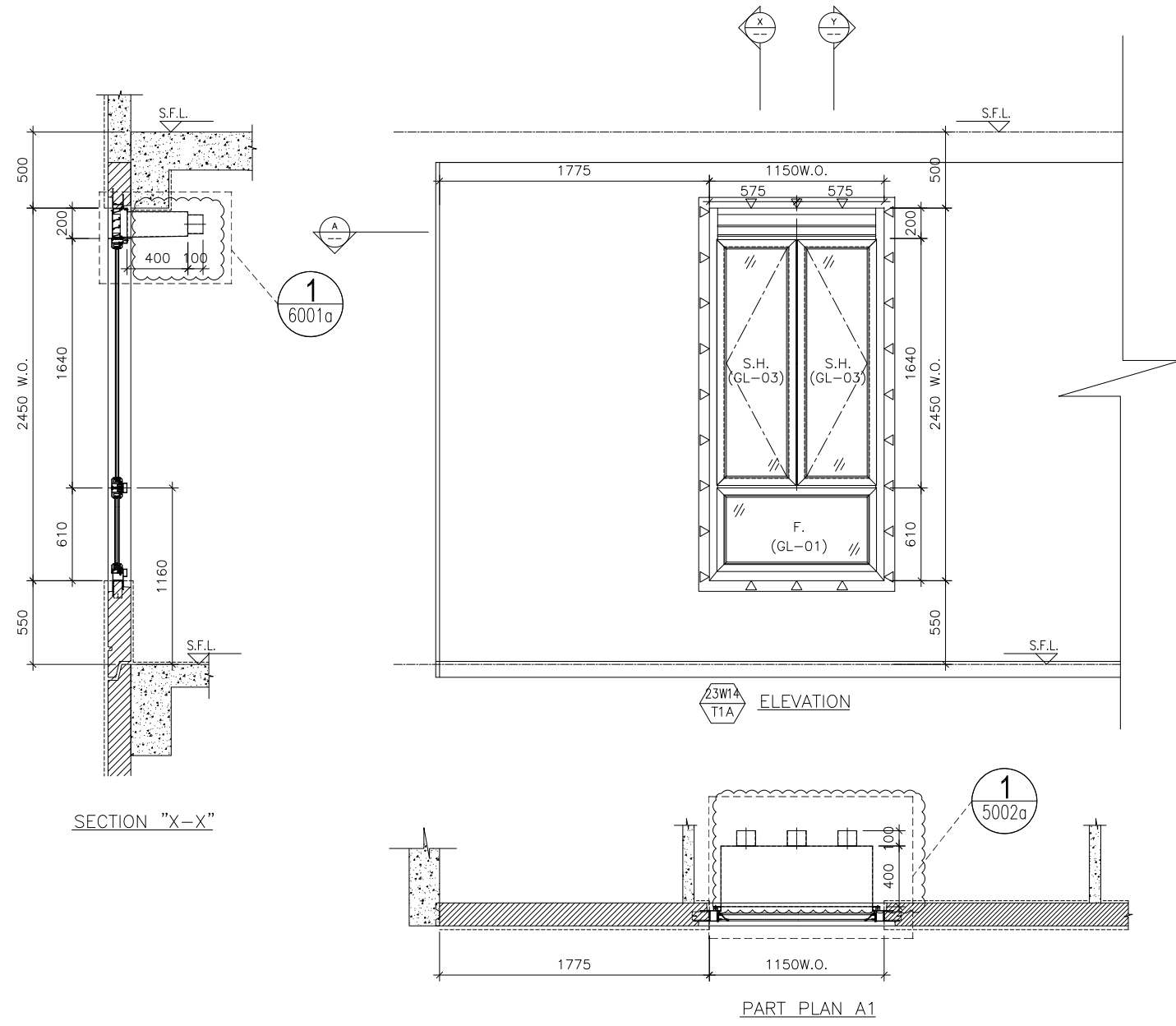

WINDOW MARK	
LOCATION	23/F M.B. & EN.B 3 AT TOWER 1 FLAT A
SECTION	70mm ALUM. SECTION
GLAZING	GL-01, GL-03
QUANTITY	1
REMARKS	FACADE (PF-22)

B.D. REF :

CLIENT :

ARCHITECT :

 101, 102, 103, 104, 105, 106, 107, 108, 109, 110, 111, 112, 113, 114, 115, 116, 117, 118, 119, 120, 121, 122, 123, 124, 125, 126, 127, 128, 129, 130, 131, 132, 133, 134, 135, 136, 137, 138, 139, 140, 141, 142, 143, 144, 145, 146, 147, 148, 149, 150, 151, 152, 153, 154, 155, 156, 157, 158, 159, 160, 161, 162, 163, 164, 165, 166, 167, 168, 169, 170, 171, 172, 173, 174, 175, 176, 177, 178, 179, 180, 181, 182, 183, 184, 185, 186, 187, 188, 189, 190, 191, 192, 193, 194, 195, 196, 197, 198, 199, 200, 201, 202, 203, 204, 205, 206, 207, 208, 209, 210, 211, 212, 213, 214, 215, 216, 217, 218, 219, 220, 221, 222, 223, 224, 225, 226, 227, 228, 229, 230, 231, 232, 233, 234, 235, 236, 237, 238, 239, 240, 241, 242, 243, 244, 245, 246, 247, 248, 249, 250, 251, 252, 253, 254, 255, 256, 257, 258, 259, 260, 261, 262, 263, 264, 265, 266, 267, 268, 269, 270, 271, 272, 273, 274, 275, 276, 277, 278, 279, 280, 281, 282, 283, 284, 285, 286, 287, 288, 289, 290, 291, 292, 293, 294, 295, 296, 297, 298, 299, 300, 301, 302, 303, 304, 305, 306, 307, 308, 309, 310, 311, 312, 313, 314, 315, 316, 317, 318, 319, 320, 321, 322, 323, 324, 325, 326, 327, 328, 329, 330, 331, 332, 333, 334, 335, 336, 337, 338, 339, 340, 341, 342, 343, 344, 345, 346, 347, 348, 349, 350, 351, 352, 353, 354, 355, 356, 357, 358, 359, 360, 361, 362, 363, 364, 365, 366, 367, 368, 369, 370, 371, 372, 373, 374, 375, 376, 377, 378, 379, 380, 381, 382, 383, 384, 385, 386, 387, 388, 389, 390, 391, 392, 393, 394, 395, 396, 397, 398, 399, 400, 401, 402, 403, 404, 405, 406, 407, 408, 409, 410, 411, 412, 413, 414, 415, 416, 417, 418, 419, 420, 421, 422, 423, 424, 425, 426, 427, 428, 429, 430, 431, 432, 433, 434, 435, 436, 437, 438, 439, 440, 441, 442, 443, 444, 445, 446, 447, 448, 449, 450, 451, 452, 453, 454, 455, 456, 457, 458, 459, 460, 461, 462, 463, 464, 465, 466, 467, 468, 469, 470, 471, 472, 473, 474, 475, 476, 477, 478, 479, 480, 481, 482, 483, 484, 485, 486, 487, 488, 489, 490, 491, 492, 493, 494, 495, 496, 497, 498, 499, 500, 501, 502, 503, 504, 505, 506, 507, 508, 509, 510, 511, 512, 513, 514, 515, 516, 517, 518, 519, 520, 521, 522, 523, 524, 525, 526, 527, 528, 529, 530, 531, 532, 533, 534, 535, 536, 537, 538, 539, 540, 541, 542, 543, 544, 545, 546, 547, 548, 549, 550, 551, 552, 553, 554, 555, 556, 557, 558, 559, 560, 561, 562, 563, 564, 565, 566, 567, 568, 569, 570, 571, 572, 573, 574, 575, 576, 577, 578, 579, 580, 581, 582, 583, 584, 585, 586, 587, 588, 589, 590, 591, 592, 593, 594, 595, 596, 597, 598, 599, 600, 601, 602, 603, 604, 605, 606, 607, 608, 609, 610, 611, 612, 613, 614, 615, 616, 617, 618, 619, 620, 621, 622, 623, 624, 625, 626, 627, 628, 629, 630, 631, 632, 633, 634, 635, 636, 637, 638, 639, 640, 641, 642, 643, 644, 645, 646, 647, 648, 649, 650, 651, 652, 653, 654, 655, 656, 657, 658, 659, 660, 661, 662, 663, 664, 665, 666, 667, 668, 669, 670, 671, 672, 673, 674, 675, 676, 677, 678, 679, 680, 681, 682, 683, 684, 685, 686, 687, 688, 689, 690, 691, 692, 693, 694, 695, 696, 697, 698, 699, 700, 701, 702, 703, 704, 705, 706, 707, 708, 709, 710, 711, 712, 713, 714, 715, 716, 717, 718, 719, 720, 721, 722, 723, 724, 725, 726, 727, 728, 729, 730, 731, 732, 733, 734, 735, 736, 737, 738, 739, 740, 741, 742, 743, 744, 745, 746, 747, 748, 749, 750, 751, 752, 753, 754, 755, 756, 757, 758, 759, 760, 761, 762, 763, 764, 765, 766, 767, 768, 769, 770, 771, 772, 773, 774, 775, 776, 777, 778, 779, 780, 781, 782, 783, 784, 785, 786, 787, 788, 789, 790, 791, 792, 793, 794, 795, 796, 797, 798, 799, 800, 801, 802, 803, 804, 805, 806, 807, 808, 809, 810, 811, 812, 813, 814, 815, 816, 817, 818, 819, 820, 821, 822, 823, 824, 825, 826, 827, 828, 829, 830, 831, 832, 833, 834, 835, 836, 837, 838, 839, 840, 841, 842, 843, 844, 845, 846, 847, 848, 849, 850, 851, 852, 853, 854, 855, 856, 857, 858, 859, 860, 861, 862, 863, 864, 865, 866, 867, 868, 869, 870, 871, 872, 873, 874, 875, 876, 877, 878, 879, 880, 881, 882, 883, 884, 885, 886, 887, 888, 889, 890, 891, 892, 893, 894, 895, 896, 897, 898, 899, 900, 901, 902, 903, 904, 905, 906, 907, 908, 909, 910, 911, 912, 913, 914, 915, 916, 917, 918, 919, 920, 921, 922, 923, 924, 925, 926, 927, 928, 929, 930, 931, 932, 933, 934, 935, 936, 937, 938, 939, 940, 941, 942, 943, 944, 945, 946, 947, 948, 949, 950, 951, 952, 953, 954, 955, 956, 957, 958, 959, 960, 961, 962, 963, 964, 965, 966, 967, 968, 969, 970, 971, 972, 973, 974, 975, 976, 977, 978, 979, 980, 981, 982, 983, 984, 985, 986, 987, 988, 989, 990, 991, 992, 993, 994, 995, 996, 997, 998, 999, 1000

NOTE :

- ALL DIMENSIONS ARE IN mm.
- ALL ELEVATIONS ARE VIEWED FROM OUTSIDE.
- ALL DIMENSIONS TO BE VERIFIED ON SITE BEFORE FABRICATION.

LEGEND :

x1 — DETAIL MARK NO.
 x001 — REFER SHEET NO.

- F.F.L. -- FINISHED FLOOR LEVEL
- S.F.L. -- STRUCTURAL FLOOR LEVEL
- (R) -- REVERSED DETAIL
- ▲ -- FIXING LOCATION
- △ -- FIXING LUG LOCATION

GLASS LEGEND

GL01 -- 8mm+12mm AIR GAP+10mm THK. I.G.U.
 GL01a -- 8mm+9mm AIR GAP+12mm THK. I.G.U.
 GL03 -- 6mm+12mm AIR GAP+6mm THK. I.G.U.
 GL04 -- 10mm THK. TEMPERED GLASS (PROTECTIVE BARRIER)
 GL05 -- 6mm+12mm AIR GAP+8mm THK. I.G.U.

A	09/12/2020	REVISION SUBJECT TO ARCH.COMMENT	lvn
NO.	DATE	REVISION	BY

JOB NO. : J-852

PROJECT :
 PROPOSED RESIDENTIAL DEVELOPMENT
 AT 139 - 147 ARGYLE STREET,
 NKIL 6005, 6035 R.P., 6036 R.P.,
 6037 R.P. & 6038 R.P.

TITLE :
 SCHEDULE FOR Plenum Box
 AT TOWER 1

DATE : 05-Dec-19	SCALE : 1:40
DRAWN BY : MN	CHECKED BY : DW

MIDI ALUMINIUM FABRICATOR LTD.
 Units 6-8, Sunray Industrial Centre, 1/F
 610 Cha Kwo Ling Road, Kowloon
 Tel:23489211-4 Fax:(852)2727666

DWG NO. : J852-SD-PB-4112 REV. : A

ELEVATION

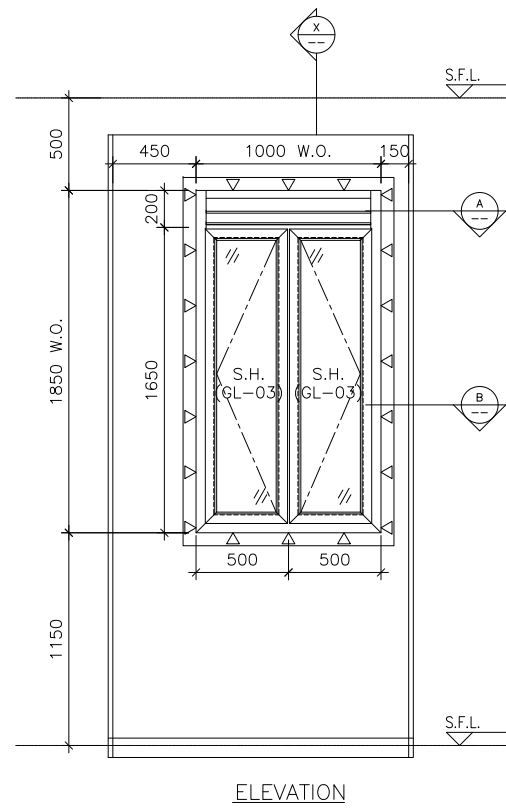

ELEVATION

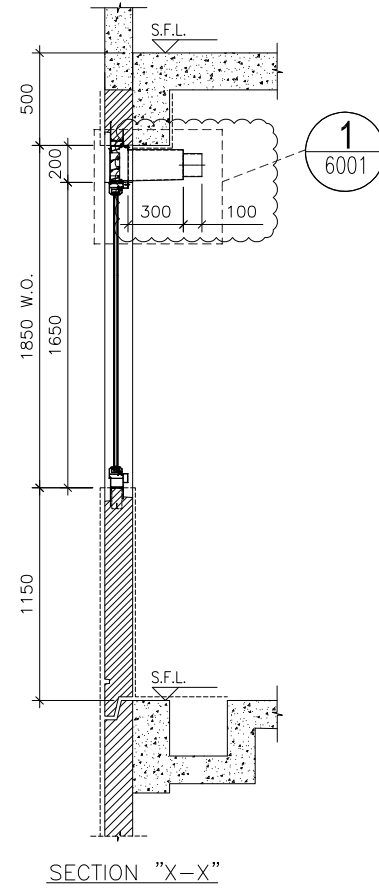

SECTION "X-X"

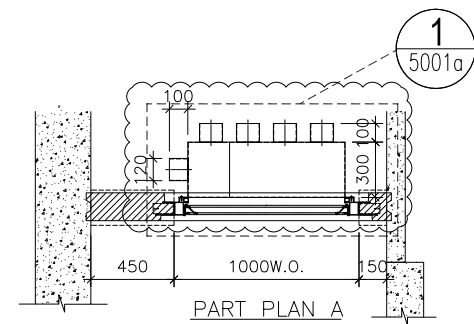

PART PLAN A

WINDOW MARK	
LOCATION	23/F KIT. AT TOWER 1 FLAT C
SECTION	70mm ALUM. SECTION
GLAZING	GL-03
QUANTITY	1
REMARKS	FACADE (PF-31)

B.D. REF :

CLIENT :

ARCHITECT :
AGC DESIGN LTD
 101, 102, 103, 104, 105, 106, 107, 108, 109, 110, 111, 112, 113, 114, 115, 116, 117, 118, 119, 120, 121, 122, 123, 124, 125, 126, 127, 128, 129, 130, 131, 132, 133, 134, 135, 136, 137, 138, 139, 140, 141, 142, 143, 144, 145, 146, 147, 148, 149, 150, 151, 152, 153, 154, 155, 156, 157, 158, 159, 160, 161, 162, 163, 164, 165, 166, 167, 168, 169, 170, 171, 172, 173, 174, 175, 176, 177, 178, 179, 180, 181, 182, 183, 184, 185, 186, 187, 188, 189, 190, 191, 192, 193, 194, 195, 196, 197, 198, 199, 200, 201, 202, 203, 204, 205, 206, 207, 208, 209, 210, 211, 212, 213, 214, 215, 216, 217, 218, 219, 220, 221, 222, 223, 224, 225, 226, 227, 228, 229, 230, 231, 232, 233, 234, 235, 236, 237, 238, 239, 240, 241, 242, 243, 244, 245, 246, 247, 248, 249, 250, 251, 252, 253, 254, 255, 256, 257, 258, 259, 260, 261, 262, 263, 264, 265, 266, 267, 268, 269, 270, 271, 272, 273, 274, 275, 276, 277, 278, 279, 280, 281, 282, 283, 284, 285, 286, 287, 288, 289, 290, 291, 292, 293, 294, 295, 296, 297, 298, 299, 300, 301, 302, 303, 304, 305, 306, 307, 308, 309, 310, 311, 312, 313, 314, 315, 316, 317, 318, 319, 320, 321, 322, 323, 324, 325, 326, 327, 328, 329, 330, 331, 332, 333, 334, 335, 336, 337, 338, 339, 340, 341, 342, 343, 344, 345, 346, 347, 348, 349, 350, 351, 352, 353, 354, 355, 356, 357, 358, 359, 360, 361, 362, 363, 364, 365, 366, 367, 368, 369, 370, 371, 372, 373, 374, 375, 376, 377, 378, 379, 380, 381, 382, 383, 384, 385, 386, 387, 388, 389, 390, 391, 392, 393, 394, 395, 396, 397, 398, 399, 400, 401, 402, 403, 404, 405, 406, 407, 408, 409, 410, 411, 412, 413, 414, 415, 416, 417, 418, 419, 420, 421, 422, 423, 424, 425, 426, 427, 428, 429, 430, 431, 432, 433, 434, 435, 436, 437, 438, 439, 440, 441, 442, 443, 444, 445, 446, 447, 448, 449, 450, 451, 452, 453, 454, 455, 456, 457, 458, 459, 460, 461, 462, 463, 464, 465, 466, 467, 468, 469, 470, 471, 472, 473, 474, 475, 476, 477, 478, 479, 480, 481, 482, 483, 484, 485, 486, 487, 488, 489, 490, 491, 492, 493, 494, 495, 496, 497, 498, 499, 500, 501, 502, 503, 504, 505, 506, 507, 508, 509, 510, 511, 512, 513, 514, 515, 516, 517, 518, 519, 520, 521, 522, 523, 524, 525, 526, 527, 528, 529, 530, 531, 532, 533, 534, 535, 536, 537, 538, 539, 540, 541, 542, 543, 544, 545, 546, 547, 548, 549, 550, 551, 552, 553, 554, 555, 556, 557, 558, 559, 560, 561, 562, 563, 564, 565, 566, 567, 568, 569, 570, 571, 572, 573, 574, 575, 576, 577, 578, 579, 580, 581, 582, 583, 584, 585, 586, 587, 588, 589, 590, 591, 592, 593, 594, 595, 596, 597, 598, 599, 600, 601, 602, 603, 604, 605, 606, 607, 608, 609, 610, 611, 612, 613, 614, 615, 616, 617, 618, 619, 620, 621, 622, 623, 624, 625, 626, 627, 628, 629, 630, 631, 632, 633, 634, 635, 636, 637, 638, 639, 640, 641, 642, 643, 644, 645, 646, 647, 648, 649, 650, 651, 652, 653, 654, 655, 656, 657, 658, 659, 660, 661, 662, 663, 664, 665, 666, 667, 668, 669, 670, 671, 672, 673, 674, 675, 676, 677, 678, 679, 680, 681, 682, 683, 684, 685, 686, 687, 688, 689, 690, 691, 692, 693, 694, 695, 696, 697, 698, 699, 700, 701, 702, 703, 704, 705, 706, 707, 708, 709, 710, 711, 712, 713, 714, 715, 716, 717, 718, 719, 720, 721, 722, 723, 724, 725, 726, 727, 728, 729, 730, 731, 732, 733, 734, 735, 736, 737, 738, 739, 740, 741, 742, 743, 744, 745, 746, 747, 748, 749, 750, 751, 752, 753, 754, 755, 756, 757, 758, 759, 760, 761, 762, 763, 764, 765, 766, 767, 768, 769, 770, 771, 772, 773, 774, 775, 776, 777, 778, 779, 780, 781, 782, 783, 784, 785, 786, 787, 788, 789, 790, 791, 792, 793, 794, 795, 796, 797, 798, 799, 800, 801, 802, 803, 804, 805, 806, 807, 808, 809, 810, 811, 812, 813, 814, 815, 816, 817, 818, 819, 820, 821, 822, 823, 824, 825, 826, 827, 828, 829, 830, 831, 832, 833, 834, 835, 836, 837, 838, 839, 840, 841, 842, 843, 844, 845, 846, 847, 848, 849, 850, 851, 852, 853, 854, 855, 856, 857, 858, 859, 860, 861, 862, 863, 864, 865, 866, 867, 868, 869, 870, 871, 872, 873, 874, 875, 876, 877, 878, 879, 880, 881, 882, 883, 884, 885, 886, 887, 888, 889, 890, 891, 892, 893, 894, 895, 896, 897, 898, 899, 900, 901, 902, 903, 904, 905, 906, 907, 908, 909, 910, 911, 912, 913, 914, 915, 916, 917, 918, 919, 920, 921, 922, 923, 924, 925, 926, 927, 928, 929, 930, 931, 932, 933, 934, 935, 936, 937, 938, 939, 940, 941, 942, 943, 944, 945, 946, 947, 948, 949, 950, 951, 952, 953, 954, 955, 956, 957, 958, 959, 960, 961, 962, 963, 964, 965, 966, 967, 968, 969, 970, 971, 972, 973, 974, 975, 976, 977, 978, 979, 980, 981, 982, 983, 984, 985, 986, 987, 988, 989, 990, 991, 992, 993, 994, 995, 996, 997, 998, 999, 1000

MAIN CONTRACTOR :

STRUCTURAL ENGINEER :

FACADE CONSULTANT:

NOTE :
 1. ALL DIMENSIONS ARE IN mm.
 2. ALL ELEVATIONS ARE VIEWED FROM OUTSIDE.
 3. ALL DIMENSIONS TO BE VERIFIED ON SITE BEFORE FABRICATION.

LEGEND :
 (x1) --- DETAIL MARK NO.
 (x001) --- REFER SHEET NO.
 1. F.F.L. --- FINISHED FLOOR LEVEL
 2. S.F.L. --- STRUCTURAL FLOOR LEVEL
 3. (R) --- REVERSED DETAIL
 4. ▲ --- FIXING LOCATION
 5. △ --- FIXING LUG LOCATION
 6. GLASS LEGEND
 GL01 --- 8mm+12mm AIR GAP+10mm THK. I.G.U.
 GL01a --- 8mm+9mm AIR GAP+12mm THK. I.G.U.
 GL03 --- 6mm+12mm AIR GAP+6mm THK. I.G.U.
 GL04 --- 10mm THK. TEMPERED GLASS (PROTECTIVE BARRIER)
 GL05 --- 6mm+12mm AIR GAP+8mm THK. I.G.U.

NO.	DATE	REVISED	BY
A	09/12/2020	REVISION SUBJECT TO ARCH.COMMENT	Ivan

JOB NO. : J-852
 PROJECT :
 PROPOSED RESIDENTIAL DEVELOPMENT
 AT 139 - 147 ARGYLE STREET,
 NKIL 6005, 6035 R.P., 6036 R.P.,
 6037 R.P. & 6038 R.P.

TITLE :
 SCHEDULE FOR Plenum Box
 AT TOWER 1

DATE : 05-Dec-19 SCALE : 1:40
 DRAWN BY : MN CHECKED BY : DW

MIDI ALUMINIUM FABRICATOR LTD.
 Units 6-8, Sunray Industrial Centre, 1/F
 610 Cha Kwo Ling Road, Kowloon
 Tel:23489211-4 Fax:(852)2727666
 DWG NO. : J852-SD-PB-4113 REV. : A

ELEVATION

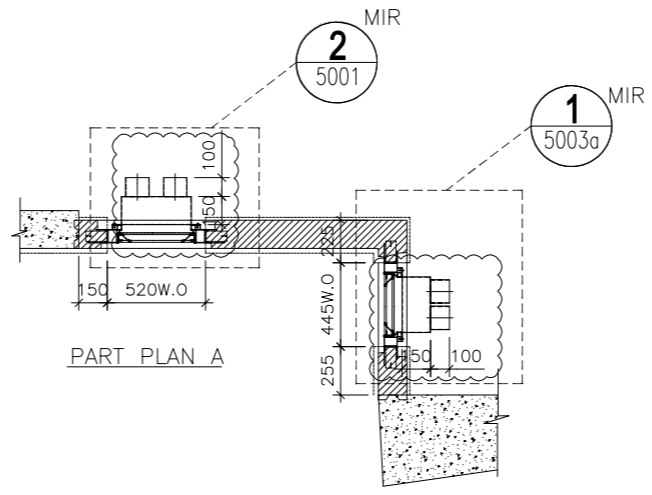
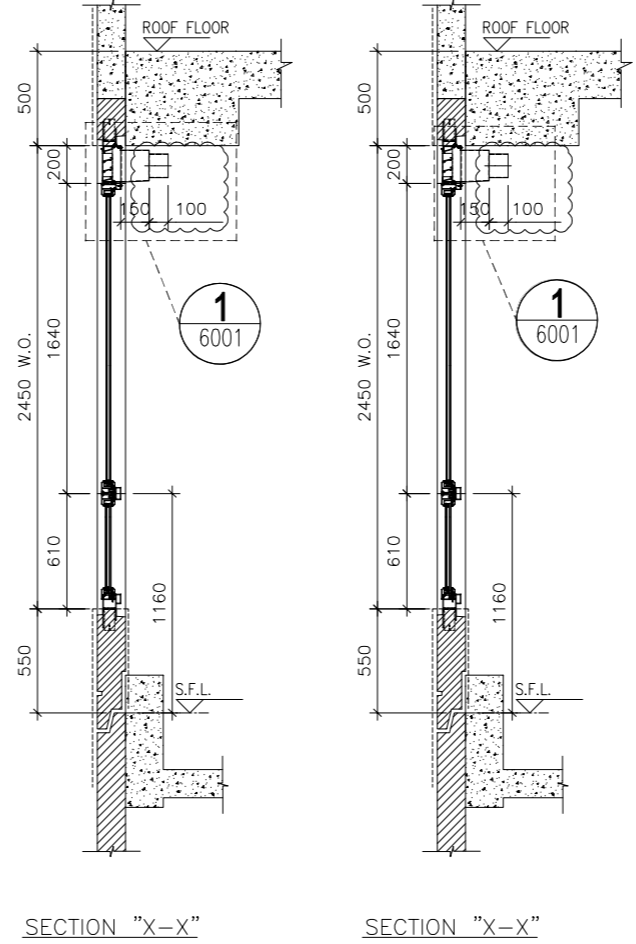
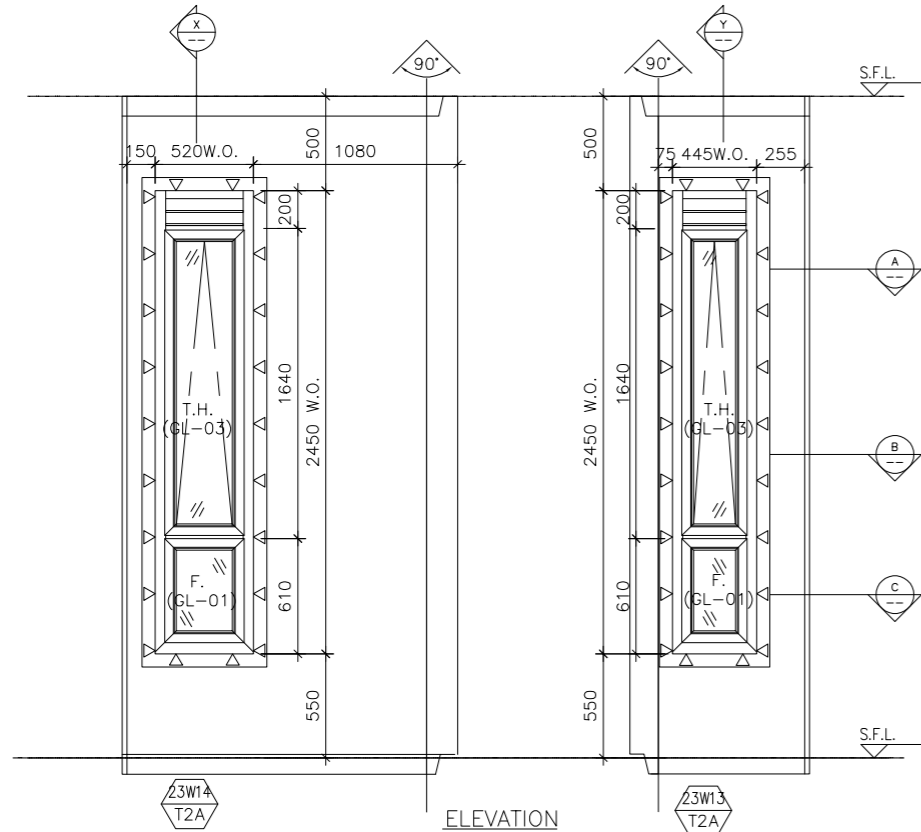

WINDOW MARK	23W14 T2A / 23W13 T2A
LOCATION	23/F E.N.B.3 & E.N.B.4 AT TOWER 2 FLAT A
SECTION	70mm ALUM. SECTION
GLAZING	GL-01, GL-03
QUANTITY	1
REMARKS	FACADE (PF-36)

B.D. REF :

CLIENT :

ARCHITECT :
AGC DESIGN LTD
 100, 14/F, D'Amico Place, 255 King's Road, North Point, Hong Kong
 Tel: (852) 2779788, Fax: (852) 2779733, Email: agc@agc.com.hk

MAIN CONTRACTOR :
Gammon

STRUCTURAL ENGINEER :
ARUP

FACADE CONSULTANT:
MEINHARDT

NOTE :
 1. ALL DIMENSIONS ARE IN mm.
 2. ALL ELEVATIONS ARE VIEWED FROM OUTSIDE.
 3. ALL DIMENSIONS TO BE VERIFIED ON SITE BEFORE FABRICATION.

LEGEND :
 X1 --- DETAIL MARK NO.
 X001 --- REFER SHEET NO.

1. F.F.L. --- FINISHED FLOOR LEVEL
 2. S.F.L. --- STRUCTURAL FLOOR LEVEL
 3. (R) --- REVERSED DETAIL

A	07/11/2020	REVISION SUBJECT TO ARCH.COMMENT	Ivan
NO.	DATE	REVISED	BY

JOB NO. : J-852
 PROJECT : PROPOSED RESIDENTIAL DEVELOPMENT AT 139 - 147 ARGYLE STREET, NKIL 6005, 6035 R.P., 6036 R.P., 6037 R.P. & 6038 R.P.
 TITLE : SCHEDULE FOR Plenum Box AT TOWER 2 (23F)

DATE : 05-Dec-19 SCALE : 1:40
 DRAWN BY : MN CHECKED BY : DW

美特鋁質有限公司
MIDI ALUMINIUM FABRICATOR LTD.
 Units 6-8, Sunray Industrial Centre, 1/F
 610 Cha Kwo Ling Road, Kowloon
 Tel: 23489211-4 Fax: (852) 27727666
 DWG NO. : J852-SD-PW-4214 REV. : A

ELEVATION

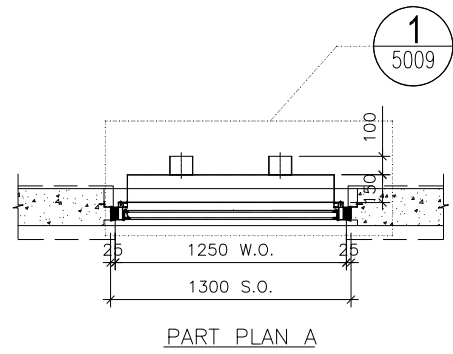
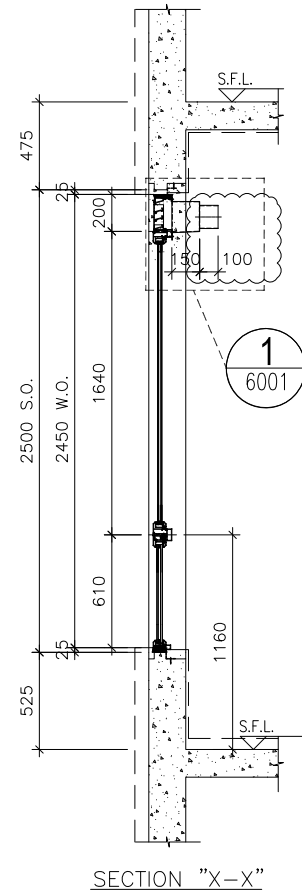
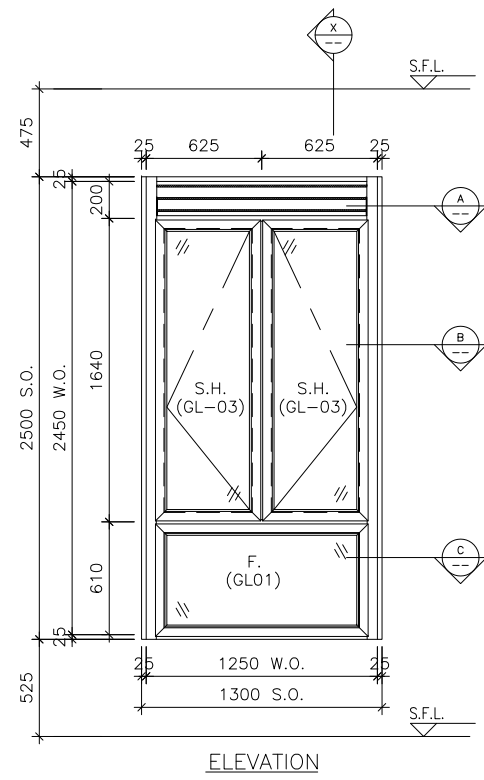

WINDOW MARK	
LOCATION	23/F BATH AT TOWER 2 FLAT A
SECTION	70mm ALUM. SECTION
GLAZING	GL-01, GL-03
QUANTITY	1
REMARKS	

B.D. REF :

CLIENT :

ARCHITECT :
AGC DESIGN LTD
 101, 102, 103, 104, 105, 106, 107, 108, 109, 110, 111, 112, 113, 114, 115, 116, 117, 118, 119, 120, 121, 122, 123, 124, 125, 126, 127, 128, 129, 130, 131, 132, 133, 134, 135, 136, 137, 138, 139, 140, 141, 142, 143, 144, 145, 146, 147, 148, 149, 150, 151, 152, 153, 154, 155, 156, 157, 158, 159, 160, 161, 162, 163, 164, 165, 166, 167, 168, 169, 170, 171, 172, 173, 174, 175, 176, 177, 178, 179, 180, 181, 182, 183, 184, 185, 186, 187, 188, 189, 190, 191, 192, 193, 194, 195, 196, 197, 198, 199, 200, 201, 202, 203, 204, 205, 206, 207, 208, 209, 210, 211, 212, 213, 214, 215, 216, 217, 218, 219, 220, 221, 222, 223, 224, 225, 226, 227, 228, 229, 230, 231, 232, 233, 234, 235, 236, 237, 238, 239, 240, 241, 242, 243, 244, 245, 246, 247, 248, 249, 250, 251, 252, 253, 254, 255, 256, 257, 258, 259, 260, 261, 262, 263, 264, 265, 266, 267, 268, 269, 270, 271, 272, 273, 274, 275, 276, 277, 278, 279, 280, 281, 282, 283, 284, 285, 286, 287, 288, 289, 290, 291, 292, 293, 294, 295, 296, 297, 298, 299, 300, 301, 302, 303, 304, 305, 306, 307, 308, 309, 310, 311, 312, 313, 314, 315, 316, 317, 318, 319, 320, 321, 322, 323, 324, 325, 326, 327, 328, 329, 330, 331, 332, 333, 334, 335, 336, 337, 338, 339, 340, 341, 342, 343, 344, 345, 346, 347, 348, 349, 350, 351, 352, 353, 354, 355, 356, 357, 358, 359, 360, 361, 362, 363, 364, 365, 366, 367, 368, 369, 370, 371, 372, 373, 374, 375, 376, 377, 378, 379, 380, 381, 382, 383, 384, 385, 386, 387, 388, 389, 390, 391, 392, 393, 394, 395, 396, 397, 398, 399, 400, 401, 402, 403, 404, 405, 406, 407, 408, 409, 410, 411, 412, 413, 414, 415, 416, 417, 418, 419, 420, 421, 422, 423, 424, 425, 426, 427, 428, 429, 430, 431, 432, 433, 434, 435, 436, 437, 438, 439, 440, 441, 442, 443, 444, 445, 446, 447, 448, 449, 450, 451, 452, 453, 454, 455, 456, 457, 458, 459, 460, 461, 462, 463, 464, 465, 466, 467, 468, 469, 470, 471, 472, 473, 474, 475, 476, 477, 478, 479, 480, 481, 482, 483, 484, 485, 486, 487, 488, 489, 490, 491, 492, 493, 494, 495, 496, 497, 498, 499, 500, 501, 502, 503, 504, 505, 506, 507, 508, 509, 510, 511, 512, 513, 514, 515, 516, 517, 518, 519, 520, 521, 522, 523, 524, 525, 526, 527, 528, 529, 530, 531, 532, 533, 534, 535, 536, 537, 538, 539, 540, 541, 542, 543, 544, 545, 546, 547, 548, 549, 550, 551, 552, 553, 554, 555, 556, 557, 558, 559, 560, 561, 562, 563, 564, 565, 566, 567, 568, 569, 570, 571, 572, 573, 574, 575, 576, 577, 578, 579, 580, 581, 582, 583, 584, 585, 586, 587, 588, 589, 590, 591, 592, 593, 594, 595, 596, 597, 598, 599, 600, 601, 602, 603, 604, 605, 606, 607, 608, 609, 610, 611, 612, 613, 614, 615, 616, 617, 618, 619, 620, 621, 622, 623, 624, 625, 626, 627, 628, 629, 630, 631, 632, 633, 634, 635, 636, 637, 638, 639, 640, 641, 642, 643, 644, 645, 646, 647, 648, 649, 650, 651, 652, 653, 654, 655, 656, 657, 658, 659, 660, 661, 662, 663, 664, 665, 666, 667, 668, 669, 670, 671, 672, 673, 674, 675, 676, 677, 678, 679, 680, 681, 682, 683, 684, 685, 686, 687, 688, 689, 690, 691, 692, 693, 694, 695, 696, 697, 698, 699, 700, 701, 702, 703, 704, 705, 706, 707, 708, 709, 710, 711, 712, 713, 714, 715, 716, 717, 718, 719, 720, 721, 722, 723, 724, 725, 726, 727, 728, 729, 730, 731, 732, 733, 734, 735, 736, 737, 738, 739, 740, 741, 742, 743, 744, 745, 746, 747, 748, 749, 750, 751, 752, 753, 754, 755, 756, 757, 758, 759, 760, 761, 762, 763, 764, 765, 766, 767, 768, 769, 770, 771, 772, 773, 774, 775, 776, 777, 778, 779, 780, 781, 782, 783, 784, 785, 786, 787, 788, 789, 790, 791, 792, 793, 794, 795, 796, 797, 798, 799, 800, 801, 802, 803, 804, 805, 806, 807, 808, 809, 810, 811, 812, 813, 814, 815, 816, 817, 818, 819, 820, 821, 822, 823, 824, 825, 826, 827, 828, 829, 830, 831, 832, 833, 834, 835, 836, 837, 838, 839, 840, 841, 842, 843, 844, 845, 846, 847, 848, 849, 850, 851, 852, 853, 854, 855, 856, 857, 858, 859, 860, 861, 862, 863, 864, 865, 866, 867, 868, 869, 870, 871, 872, 873, 874, 875, 876, 877, 878, 879, 880, 881, 882, 883, 884, 885, 886, 887, 888, 889, 890, 891, 892, 893, 894, 895, 896, 897, 898, 899, 900, 901, 902, 903, 904, 905, 906, 907, 908, 909, 910, 911, 912, 913, 914, 915, 916, 917, 918, 919, 920, 921, 922, 923, 924, 925, 926, 927, 928, 929, 930, 931, 932, 933, 934, 935, 936, 937, 938, 939, 940, 941, 942, 943, 944, 945, 946, 947, 948, 949, 950, 951, 952, 953, 954, 955, 956, 957, 958, 959, 960, 961, 962, 963, 964, 965, 966, 967, 968, 969, 970, 971, 972, 973, 974, 975, 976, 977, 978, 979, 980, 981, 982, 983, 984, 985, 986, 987, 988, 989, 990, 991, 992, 993, 994, 995, 996, 997, 998, 999, 1000

MAIN CONTRACTOR :
Gammon

STRUCTURAL ENGINEER :
ARUP

FACADE CONSULTANT:
MEINHARDT

NOTE :
 1. ALL DIMENSIONS ARE IN mm.
 2. ALL ELEVATIONS ARE VIEWED FROM OUTSIDE.
 3. ALL DIMENSIONS TO BE VERIFIED ON SITE BEFORE FABRICATION.

LEGEND :
 (X1) --- DETAIL MARK NO.
 (X001) --- REFER SHEET NO.
 1. F.F.L. --- FINISHED FLOOR LEVEL
 2. S.F.L. --- STRUCTURAL FLOOR LEVEL
 3. (R) --- REVERSED DETAIL

NO.	DATE	REVISION	BY
A	09/12/2020	REVISION SUBJECT TO ARCH.COMMENT	Ivan

JOB NO. : J-852
 PROJECT : PROPOSED RESIDENTIAL DEVELOPMENT AT 139 - 147 ARGYLE STREET, NKIL 6005, 6035 R.P., 6036 R.P., 6037 R.P. & 6038 R.P.

TITLE : SCHEDULE FOR Plenum Box At IN-SITU ALUM. WINDOW(23F)

DATE : 05-FEB-20 SCALE : 1:100
 DRAWN BY : MN CHECKED BY : DW

美特鋁質有限公司
MIDI ALUMINIUM FABRICATOR LTD.
 Units 6-8, Sunray Industrial Centre, 1/F
 610 Cha Kwo Ling Road, Kowloon
 Tel:23489211-4 Fax:(852)27727666
 DWG NO. : J852-SD-PB-4215 REV. : A

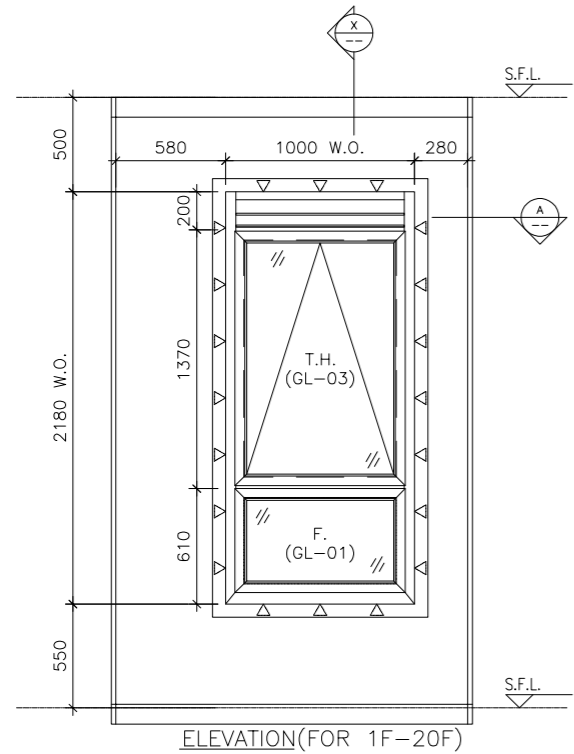

ELEVATION(FOR 1F-20F)

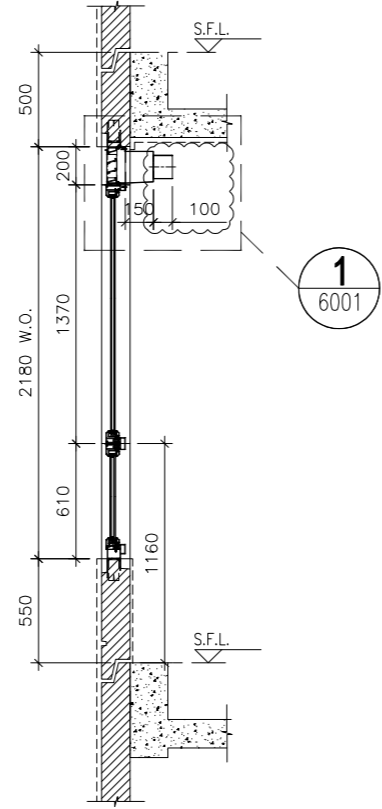

SECTION "X-X"(FOR 1F-20F)

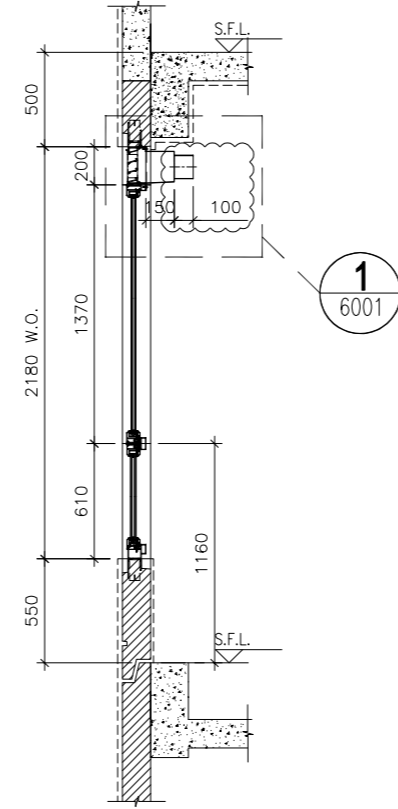

SECTION "X-X"(FOR 21F)

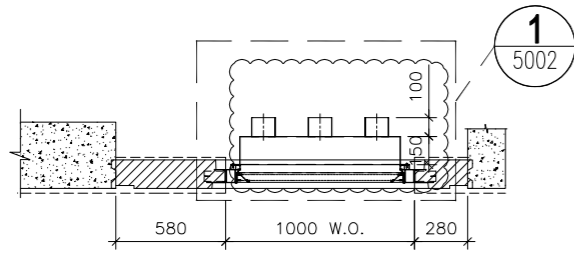

PART PLAN A

ELEVATION

WINDOW MARK	W4 T3A
LOCATION	1/F-21/F M.B. AT TOWER 3 FLAT A
SECTION	70mm ALUM. SECTION
GLAZING	GL-01, GL-03
QUANTITY	18
REMARKS	FACADE (PF-13)

B.D. REF :

CLIENT :

ARCHITECT :
AGC DESIGN LTD
 100, 14/F, D'Amor Plaza, 225, King's Road, North Point, Hong Kong
 Tel: (852) 27797812, Fax: (852) 27797133, Email: agc@agcdesign.com.hk

MAIN CONTRACTOR :
Gammon

STRUCTURAL ENGINEER :
ARUP

FACADE CONSULTANT:
MEINHARDT

- NOTE :
- ALL DIMENSIONS ARE IN mm.
 - ALL ELEVATIONS ARE VIEWED FROM OUTSIDE.
 - ALL DIMENSIONS TO BE VERIFIED ON SITE BEFORE FABRICATION.
- LEGEND :
- X1 --- DETAIL MARK NO.
 X001 --- REFER SHEET NO.
- F.F.L. --- FINISHED FLOOR LEVEL
 - S.F.L. --- STRUCTURAL FLOOR LEVEL
 - (R) --- REVERSED DETAIL
 - ▲ --- FIXING LOCATION
 - △ --- FIXING LUG LOCATION
6. GLASS LEGEND
- GL01 --- 8mm+12mm AIR GAP+10mm THK. I.G.U.
 - GL01α --- 8mm+12mm AIR GAP+12mm THK. I.G.U.
 - GL02 --- 10mm THK. TEMPERED GLASS (SPANDREL GLASS)
 - GL03 --- 6mm+12mm AIR GAP+6mm THK. I.G.U.
 - GL04 --- 10mm THK. TEMPERED GLASS (PROTECTIVE BARRIER)
 - GL05 --- 6mm+12mm AIR GAP+8mm THK. I.G.U.

A	07/11/2020	REVISION SUBJECT TO ARCH.COMMENT	Ivan
NO.	DATE	REVISED	BY

JOB NO. : J-852

PROJECT :
 PROPOSED RESIDENTIAL DEVELOPMENT
 AT 139 - 147 ARGYLE STREET,
 NKIL 6005, 6035 R.P., 6036 R.P.,
 6037 R.P. & 6038 R.P.

TITLE :
 SCHEDULE FOR Plenum Box
 AT TOWER 3 (1-21F)

DATE : 05-Dec-19 SCALE : 1:40

DRAWN BY : MN CHECKED BY : DW

美特鋁質有限公司
MIDI ALUMINIUM FABRICATOR LTD.
 Units 6-8, Sunray Industrial Centre, 1/F
 610 Cha Kwo Ling Road, Kowloon
 Tel: 23489211-4 Fax: (852) 27727666

DWG NO. : J852-SD-PB-4301 REV. : A

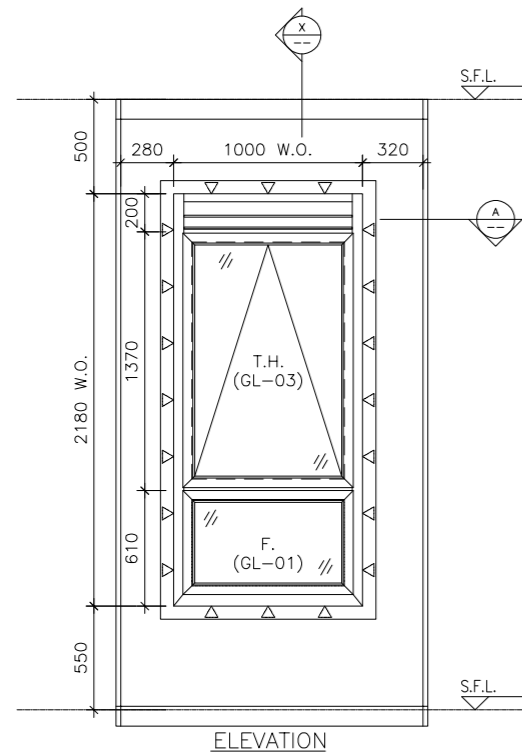

ELEVATION

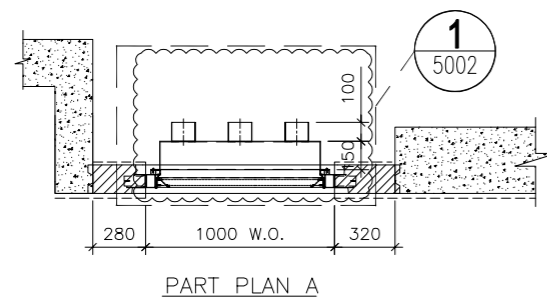

PART PLAN A

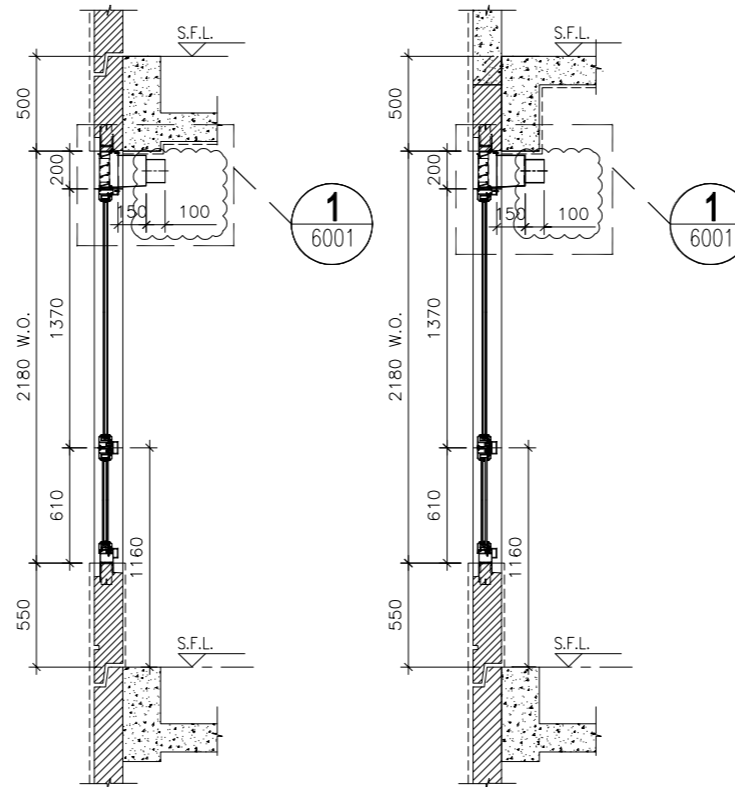

SECTION "X-X"(FOR 1F-20F)

SECTION "X-X"(FOR 21F)

B.D. REF :

CLIENT :

ARCHITECT :



MAIN CONTRACTOR :



STRUCTURAL ENGINEER :



FACADE CONSULTANT:



NOTE :

1. ALL DIMENSIONS ARE IN mm.
2. ALL ELEVATIONS ARE VIEWED FROM OUTSIDE.
3. ALL DIMENSIONS TO BE VERIFIED ON SITE BEFORE FABRICATION.

LEGEND :

- X1 --- DETAIL MARK NO.
- X001 --- REFER SHEET NO.

1. F.F.L. -- FINISHED FLOOR LEVEL
2. S.F.L. -- STRUCTURAL FLOOR LEVEL
3. (R) -- REVERSED DETAIL
4. ▲ -- FIXING LOCATION
5. △ -- FIXING LUG LOCATION

6. GLASS LEGEND

- GL01 -- 8mm+12mm AIR GAP+10mm THK. I.G.U.
- GL01α -- 8mm+12mm AIR GAP+12mm THK. I.G.U.
- GL02 -- 10mm THK. TEMPERED GLASS (SPANDREL GLASS)
- GL03 -- 6mm+12mm AIR GAP+6mm THK. I.G.U.
- GL04 -- 10mm THK. TEMPERED GLASS (PROTECTIVE BARRIER)
- GL05 -- 6mm+12mm AIR GAP+8mm THK. I.G.U.

NO.	DATE	REVISION SUBJECT TO ARCH.COMMENT	REVISED	BY
A	07/11/2020	REVISION SUBJECT TO ARCH.COMMENT		Ivan

JOB NO. : J-852

PROJECT :
PROPOSED RESIDENTIAL DEVELOPMENT
AT 139 - 147 ARGYLE STREET,
NKIL 6005, 6035 R.P., 6036 R.P.,
6037 R.P. & 6038 R.P.

TITLE :
SCHEDULE FOR Plenum Box
AT TOWER 3 (1-21F)

DATE : 05-Dec-19 SCALE : 1:40

DRAWN BY : MN CHECKED BY : DW

美特鋁質有限公司
MIDI ALUMINIUM FABRICATOR LTD.
Units 6-8, Sunray Industrial Centre, 1/F
610 Cha Kwo Ling Road, Kowloon
Tel:23489211-4 Fax:(852)27727666

DWG NO. : J852-SD-PB-4302 REV. : A

WINDOW MARK



LOCATION 1/F-21/F EN.B. AT TOWER 3 FLAT A

SECTION 70mm ALUM. SECTION

GLAZING GL-01, GL-03

QUANTITY 18

REMARKS FACADE (PF-14)

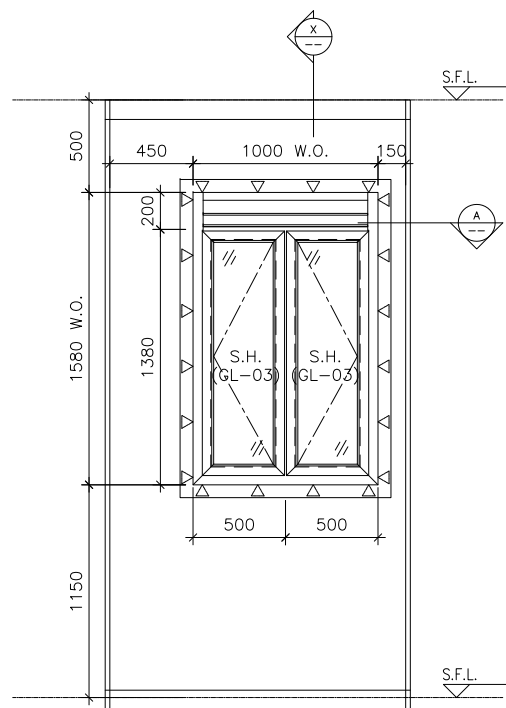

ELEVATION

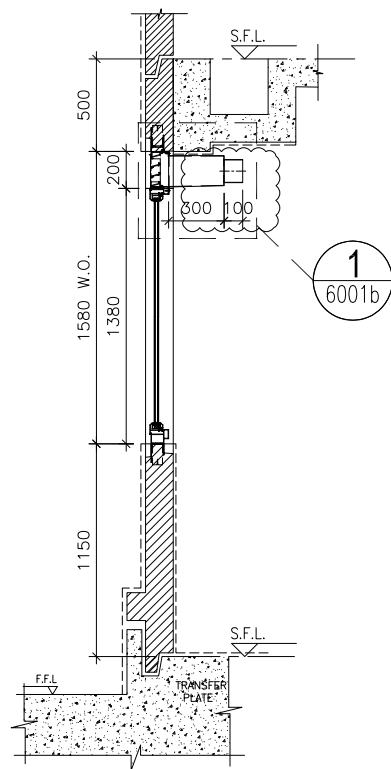

SECTION "X-X"(FOR 1F)

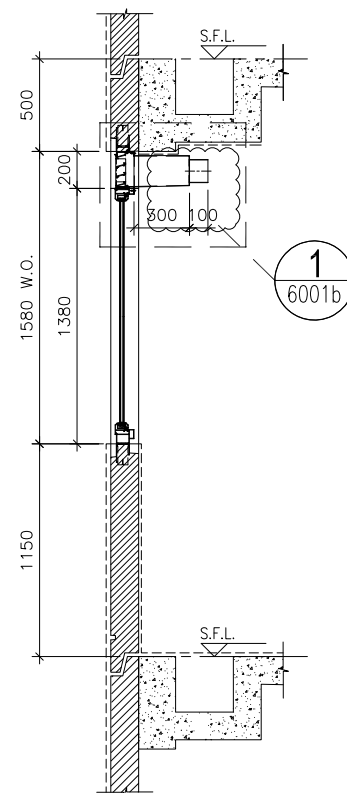

SECTION "X-X"(FOR 2F-21F)

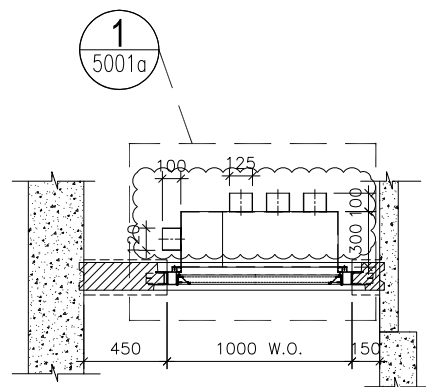

PART PLAN A

ELEVATION

WINDOW MARK



LOCATION 1/F-21/F KIT. AT TOWER 3 FLAT C

SECTION 70mm ALUM. SECTION

GLAZING GL-03

QUANTITY 18

REMARKS FACADE (PF-25)

B.D. REF :

CLIENT :

ARCHITECT :

AGC
DESIGN LTD

MAIN CONTRACTOR :

Gammon

STRUCTURAL ENGINEER :

ARUP

FACADE CONSULTANT:

MEINHARDT

- NOTE :
1. ALL DIMENSIONS ARE IN mm.
 2. ALL ELEVATIONS ARE VIEWED FROM OUTSIDE.
 3. ALL DIMENSIONS TO BE VERIFIED ON SITE BEFORE FABRICATION.

- LEGEND :
- (x1) --- DETAIL MARK NO.
 - (x001) --- REFER SHEET NO.
 - 1. F.F.L. --- FINISHED FLOOR LEVEL
 - 2. S.F.L. --- STRUCTURAL FLOOR LEVEL
 - 3. (R) --- REVERSED DETAIL
 - 4. ▲ --- FIXING LOCATION
 - 5. △ --- FIXING LUG LOCATION
 - 6. GLASS LEGEND
 - GL01 --- 8mm+12mm AIR GAP+10mm THK. I.G.U.
 - GL01a --- 8mm+12mm AIR GAP+12mm THK. I.G.U.
 - GL02 --- 10mm THK. TEMPERED GLASS (SPANDREL GLASS)
 - GL03 --- 6mm+12mm AIR GAP+6mm THK. I.G.U.
 - GL04 --- 10mm THK. TEMPERED GLASS (PROTECTIVE BARRIER)
 - GL05 --- 6mm+12mm AIR GAP+8mm THK. I.G.U.

A	09/12/2020	REVISION SUBJECT TO ARCH.COMMENT	Ivan
A	07/11/2020	REVISION SUBJECT TO ARCH.COMMENT	Ivan
NO.	DATE	REVISED	BY

JOB NO. : J-852
 PROJECT : PROPOSED RESIDENTIAL DEVELOPMENT AT 139 - 147 ARGYLE STREET, NKIL 6005, 6035 R.P., 6036 R.P., 6037 R.P. & 6038 R.P.

TITLE : SCHEDULE FOR Plenum Box AT TOWER 3 (1-21F)

DATE : 05-Dec-19 SCALE : 1:40

DRAWN BY : MN CHECKED BY : DW

美特鋁質有限公司
MIDI ALUMINIUM FABRICATOR LTD.
 Units 6-8, Sunray Industrial Centre, 1/F
 610 Cha Kwo Ling Road, Kowloon
 Tel:23489211-4 Fax:(852)2727666

DWG NO. : J852-SD-PB-4303 REV. : A

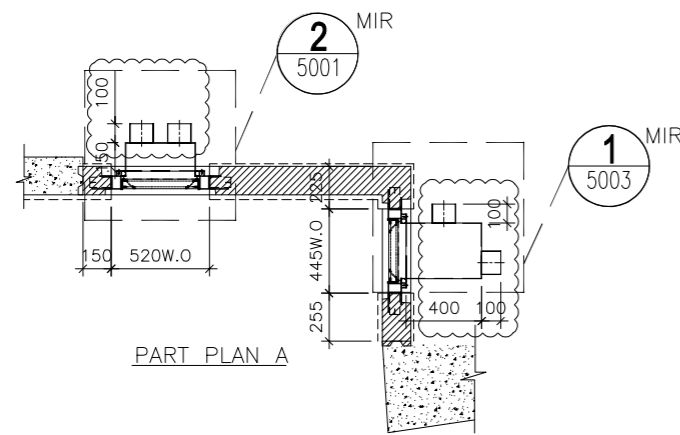
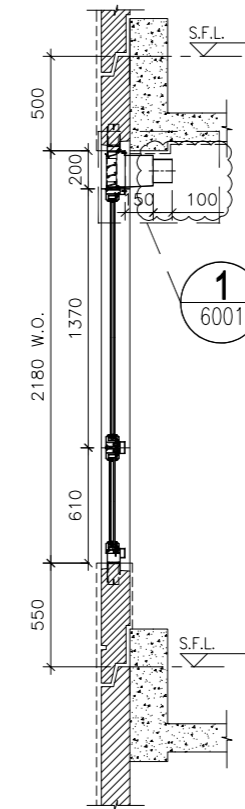
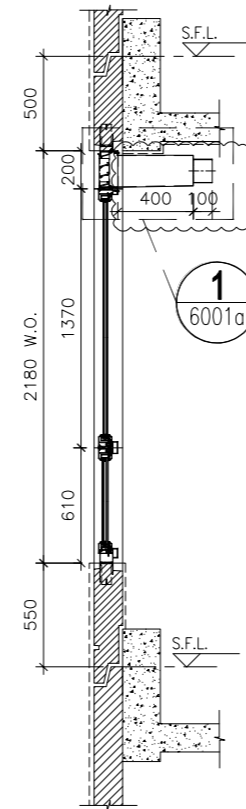
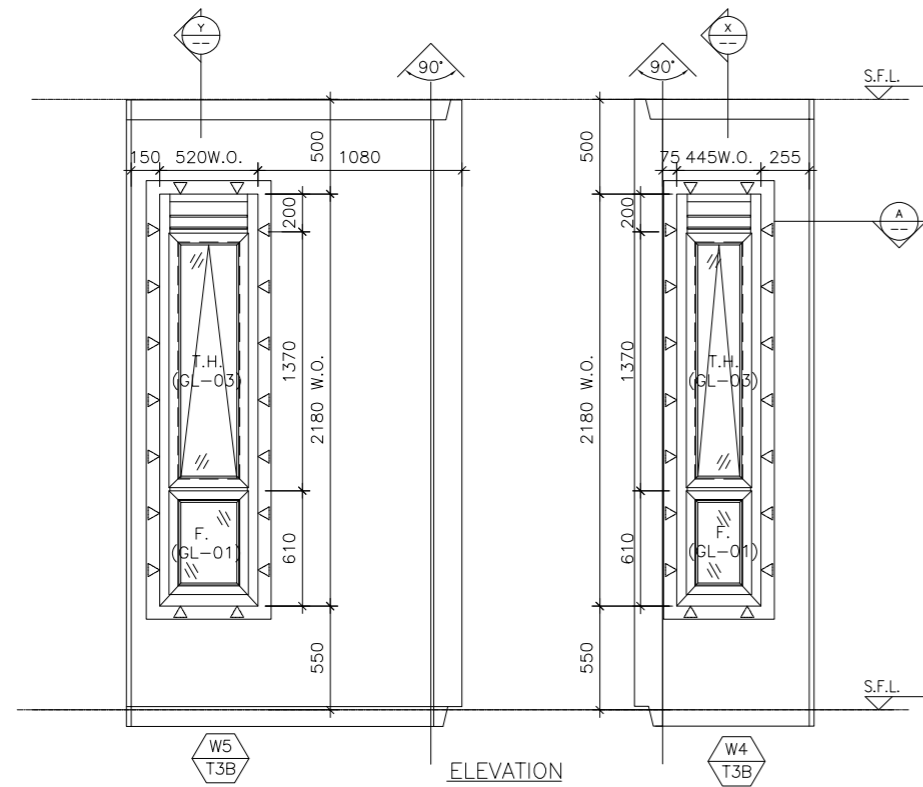

ELEVATION

SECTION "X-X"

SECTION "Y-Y"

PART PLAN A

B.D. REF :

CLIENT :

ARCHITECT :
AGC DESIGN LTD
 100, 14/F, Domain Place, 255, King's Road, North Point, Hong Kong
 Tel: (852) 27797882, Fax: (852) 27797833, Email: agc@agcdesign.com.hk

MAIN CONTRACTOR :
Gammon

STRUCTURAL ENGINEER :
ARUP

FACADE CONSULTANT:
MEINHARDT

NOTE :
 1. ALL DIMENSIONS ARE IN mm.
 2. ALL ELEVATIONS ARE VIEWED FROM OUTSIDE.
 3. ALL DIMENSIONS TO BE VERIFIED ON SITE BEFORE FABRICATION.

LEGEND :
 X1 --- DETAIL MARK NO.
 X001 --- REFER SHEET NO.

1. F.F.L. --- FINISHED FLOOR LEVEL
 2. S.F.L. --- STRUCTURAL FLOOR LEVEL
 3. (R) --- REVERSED DETAIL
 4. ▲ --- FIXING LOCATION
 5. △ --- FIXING LUG LOCATION
 6. GLASS LEGEND
 GL01 --- 8mm+12mm AIR GAP+10mm THK. I.G.U.
 GL01a --- 8mm+12mm AIR GAP+12mm THK. I.G.U.
 GL02 --- 10mm THK. TEMPERED GLASS (SPANDREL GLASS)
 GL03 --- 6mm+12mm AIR GAP+6mm THK. I.G.U.
 GL04 --- 10mm THK. TEMPERED GLASS (PROTECTIVE BARRIER)
 GL05 --- 6mm+12mm AIR GAP+8mm THK. I.G.U.

A	07/11/2020	REVISION SUBJECT TO ARCH.COMMENT	Ivan
NO.	DATE	REVISED	BY

JOB NO. : J-852
 PROJECT : PROPOSED RESIDENTIAL DEVELOPMENT AT 139 - 147 ARGYLE STREET, NKIL 6005, 6035 R.P., 6036 R.P., 6037 R.P. & 6038 R.P.
 TITLE : SCHEDULE FOR Plenum Box AT TOWER 3 (1-21F)

DATE : 05-Dec-19 SCALE : 1:40
 DRAWN BY : MN CHECKED BY : DW

美特鋁質有限公司
MIDI ALUMINIUM FABRICATOR LTD.
 Units 6-8, Sunray Industrial Centre, 1/F
 610 Cha Kwo Ling Road, Kowloon
 Tel: 23489211-4 Fax: (852) 27727666
 DWG NO. : J852-SD-PB-4304 REV. : A

WINDOW MARK	W5 / W4 / T3B / T3B
LOCATION	1/F-21/F M.B. & EN.B. AT TOWER 3 FLAT B
SECTION	70mm ALUM. SECTION
GLAZING	GL-01, GL-03
QUANTITY	18 / 18
REMARKS	FACADE (PF-34)

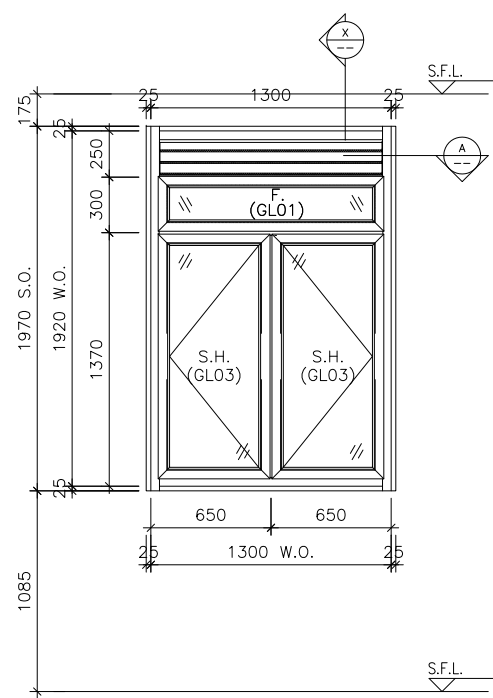

ELEVATION

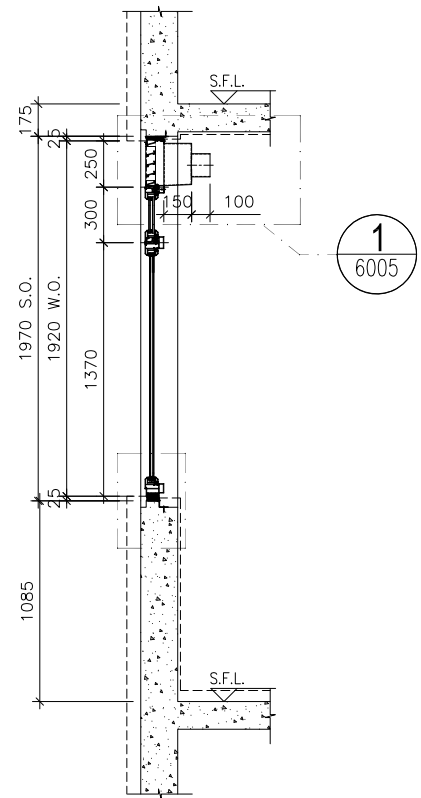

SECTION "X-X"

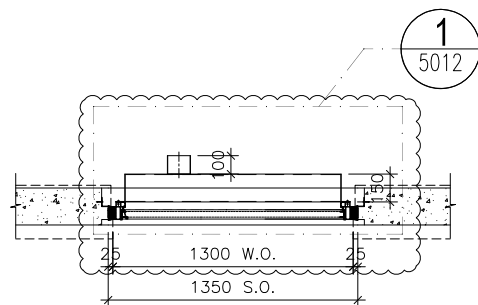

PART PLAN A

ELEVATION

WINDOW MARK	W10 T3A
LOCATION	1/F~20/F KIT. AT TOWER 3 FLAT A
SECTION	70mm ALUM. SECTION
GLAZING	GL01, GL03
QUANTITY	18
REMARKS	

B.D. REF :

CLIENT :

ARCHITECT :
AGC DESIGN LTD

MAIN CONTRACTOR :
Gammon

STRUCTURAL ENGINEER :
ARUP

FACADE CONSULTANT:
MEINHARDT

NOTE :
1. ALL DIMENSIONS ARE IN mm.
2. ALL ELEVATIONS ARE VIEWED FROM OUTSIDE.
3. ALL DIMENSIONS TO BE VERIFIED ON SITE BEFORE FABRICATION.

LEGEND :
 (x1) --- DETAIL MARK NO.
 (x001) --- REFER SHEET NO.
 1. F.F.L. --- FINISHED FLOOR LEVEL
 2. S.F.L. --- STRUCTURAL FLOOR LEVEL
 3. (R) --- REVERSED DETAIL
 4. (A) --- FIXING LOCATION
 5. Δ --- FIXING LUG LOCATION
 6. GLASS LEGEND
 GL01 --- 8mm+12mm AIR GAP+10mm THK. I.G.U.
 GL01a --- 8mm+12mm AIR GAP+12mm THK. I.G.U.
 GL02 --- 10mm THK. TEMPERED GLASS (SPANDREL GLASS)
 GL03 --- 6mm+12mm AIR GAP+6mm THK. I.G.U.
 GL04 --- 10mm THK. TEMPERED GLASS (PROTECTIVE BARRIER)
 GL05 --- 6mm+12mm AIR GAP+8mm THK. I.G.U.

NO.	DATE	REVISION	BY
A	09/12/2020	REVISION SUBJECT TO ARCH.COMMENT	lvn

JOB NO. : J-852
 PROJECT : PROPOSED RESIDENTIAL DEVELOPMENT AT 139 - 147 ARGYLE STREET, NKIL 6005, 6035 R.P., 6036 R.P., 6037 R.P. & 6038 R.P.

TITLE : SCHEDULE FOR Plenum Box At IN-SITU ALUM. WINDOW(T3: 1-21F)

DATE : 05-FEB-20 SCALE : 1:100

DRAWN BY : MN CHECKED BY : DW

美特鋁質有限公司
MIDI ALUMINIUM FABRICATOR LTD.
 Units 6-8, Sunray Industrial Centre, 1/F
 610 Cha Kwo Ling Road, Kowloon
 Tel:23489211-4 Fax:(852)2727666

DWG NO. : J852-SD-PB-4305 REV. : A

B.D. REF :

CLIENT :

ARCHITECT :
AGC DESIGN LTD
 100, 1/F, D'Almeida Place, 255, King's Road, North Point, Hong Kong
 Tel: (852) 25797816, Fax: (852) 25797133, Email: agc@agc.com.hk

MAIN CONTRACTOR :
Gammon

STRUCTURAL ENGINEER :
ARUP

FACADE CONSULTANT:
MEINHARDT

NOTE :
 1. ALL DIMENSIONS ARE IN mm.
 2. ALL ELEVATIONS ARE VIEWED FROM OUTSIDE.
 3. ALL DIMENSIONS TO BE VERIFIED ON SITE BEFORE FABRICATION.

LEGEND :

X1 --- DETAIL MARK NO.
 X001 --- REFER SHEET NO.

1. F.F.L. --- FINISHED FLOOR LEVEL
 2. S.F.L. --- STRUCTURAL FLOOR LEVEL
 3. (R) --- REVERSED DETAIL
 4. ▲ --- FIXING LOCATION
 5. △ --- FIXING LUG LOCATION
 6. GLASS LEGEND
 GL01 --- 8mm+12mm AIR GAP+10mm THK. I.G.U.
 GL01α --- 8mm+12mm AIR GAP+12mm THK. I.G.U.
 GL02 --- 10mm THK. TEMPERED GLASS (SPANDREL GLASS)
 GL03 --- 6mm+12mm AIR GAP+6mm THK. I.G.U.
 GL04 --- 10mm THK. TEMPERED GLASS (PROTECTIVE BARRIER)
 GL05 --- 6mm+12mm AIR GAP+8mm THK. I.G.U.

NO.	DATE	REVISION SUBJECT TO ARCH.COMMENT	BY
A	07/11/2020	REVISION SUBJECT TO ARCH.COMMENT	Ivan

JOB NO. : J-852
 PROJECT :
 PROPOSED RESIDENTIAL DEVELOPMENT
 AT 139 - 147 ARGYLE STREET,
 NKIL 6005, 6035 R.P., 6036 R.P.,
 6037 R.P. & 6038 R.P.

TITLE :
 SCHEDULE FOR Plenum Box
 At IN-SITU ALUM. WINDOW (T3: 1-21F)

DATE : 05-FEB-20 SCALE : 1:100
 DRAWN BY : MN CHECKED BY : DW

美特鋁質有限公司
MIDI ALUMINIUM FABRICATOR LTD.
 Units 6-8, Sunray Industrial Centre, 1/F
 610 Cha Kwo Ling Road, Kowloon
 Tel: 23489211-4 Fax: (852) 27727666
 DWG NO. : J852-SD-PB-4306 REV. : A

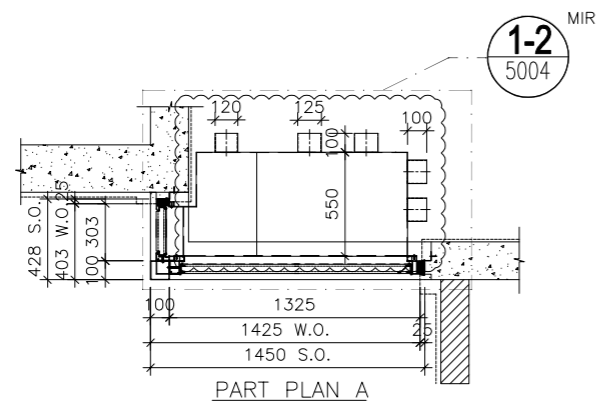
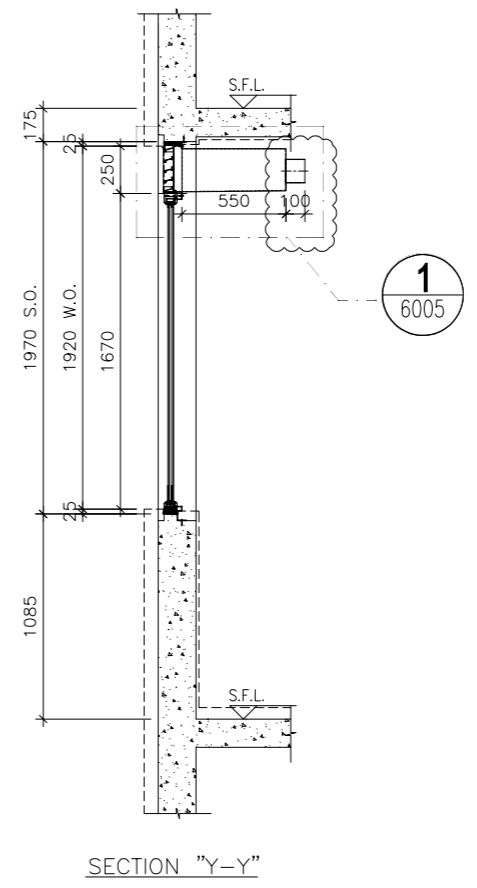
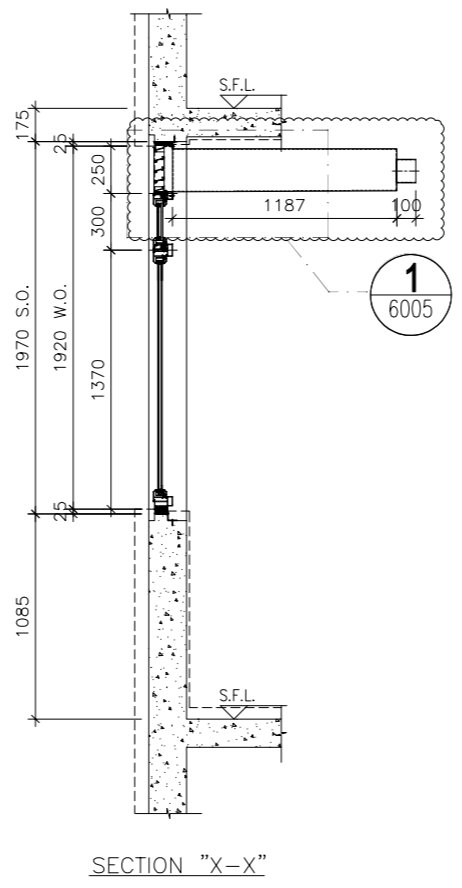
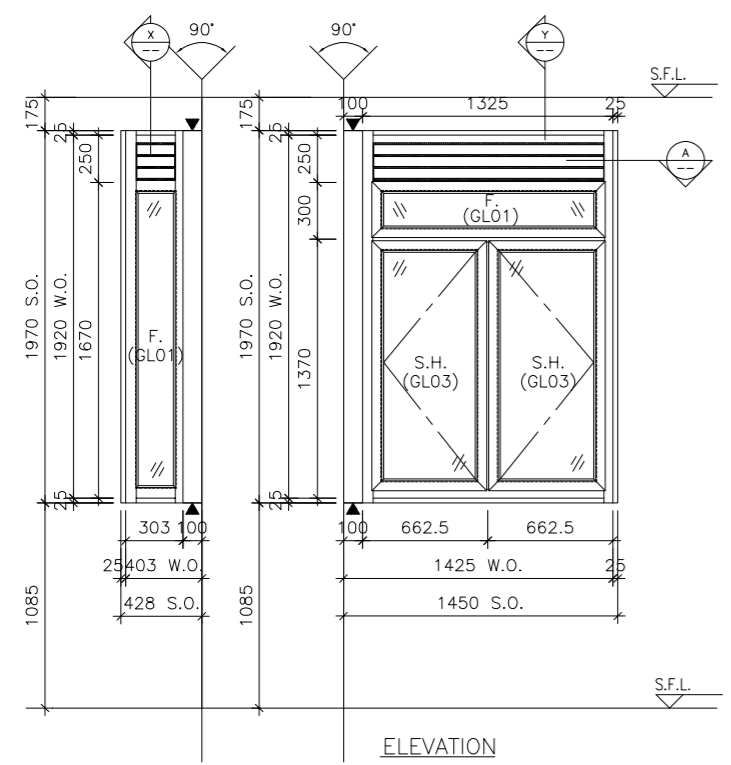

ELEVATION

WINDOW MARK
 W8
 T3B

LOCATION : 1/F~21/F KIT. AT TOWER 3 FLAT B
 SECTION : 50mm ALUM. SECTION
 GLAZING : GL01, GL03
 QUANTITY : 18
 REMARKS :

ELEVATION

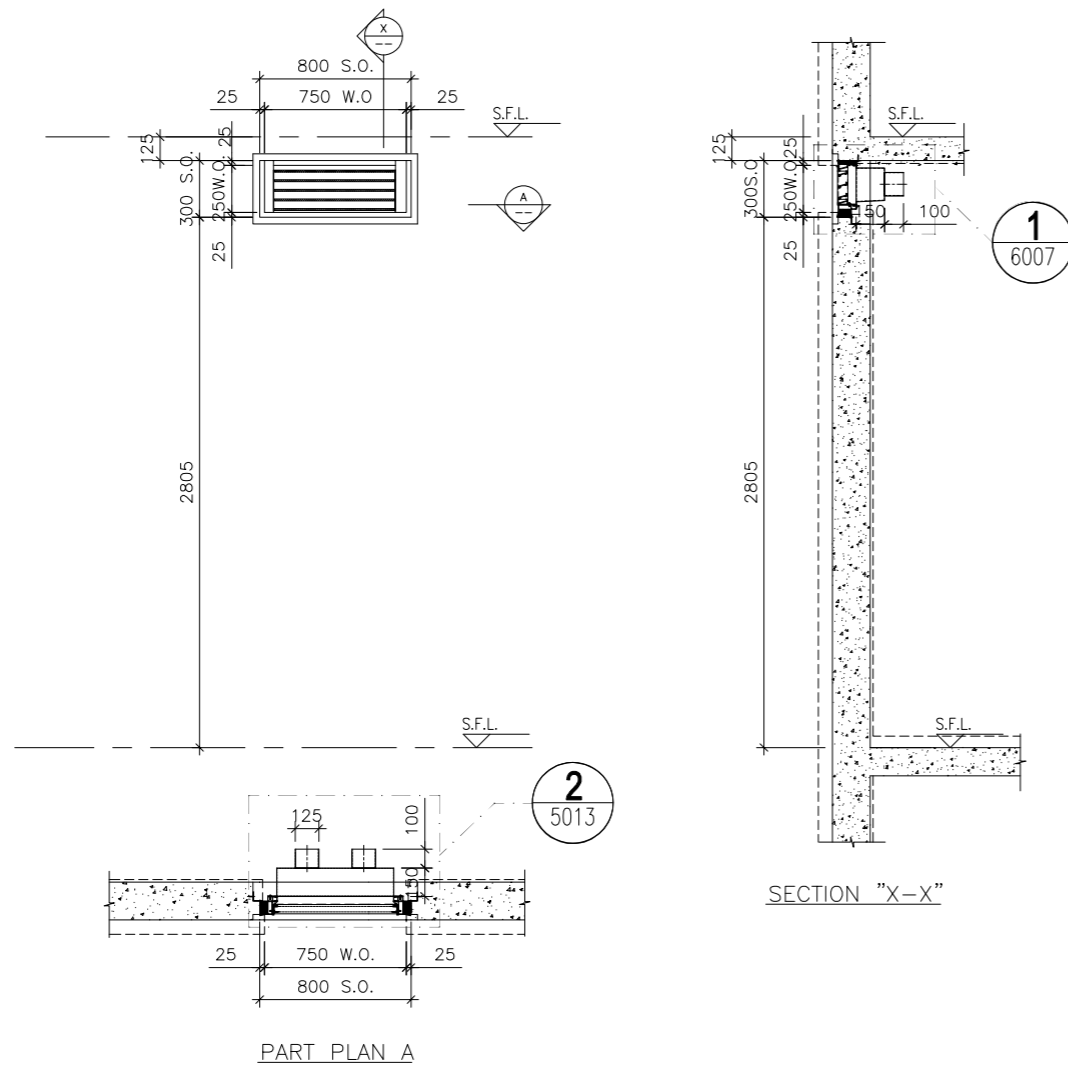

B.D. REF :

CLIENT :

ARCHITECT :
AGC DESIGN LTD
 100, 14/F, D'Almeida Place, 255, King's Road, North Point, Hong Kong
 Tel: (852) 2779788, Fax: (852) 2779788, Email: agc@agcdesign.com.hk

MAIN CONTRACTOR :
Gammon

STRUCTURAL ENGINEER :
ARUP

FACADE CONSULTANT:
MEINHARDT

NOTE :
 1. ALL DIMENSIONS ARE IN mm.
 2. ALL ELEVATIONS ARE VIEWED FROM OUTSIDE.
 3. ALL DIMENSIONS TO BE VERIFIED ON SITE BEFORE FABRICATION.

LEGEND :
 X1 --- DETAIL MARK NO.
 X001 --- REFER SHEET NO.
 1. F.F.L. --- FINISHED FLOOR LEVEL
 2. S.F.L. --- STRUCTURAL FLOOR LEVEL
 3. (R) --- REVERSED DETAIL
 4. ▲ --- FIXING LOCATION
 5. △ --- FIXING LUG LOCATION
 6. GLASS LEGEND
 GL01 --- 8mm+12mm AIR GAP+10mm THK. I.G.U.
 GL01α --- 8mm+12mm AIR GAP+12mm THK. I.G.U.
 GL02 --- 10mm THK. TEMPERED GLASS (SPANDREL GLASS)
 GL03 --- 6mm+12mm AIR GAP+6mm THK. I.G.U.
 GL04 --- 10mm THK. TEMPERED GLASS (PROTECTIVE BARRIER)
 GL05 --- 6mm+12mm AIR GAP+8mm THK. I.G.U.

NO.	DATE	REVISED	BY
-----	------	---------	----

JOB NO. : J-852
 PROJECT : PROPOSED RESIDENTIAL DEVELOPMENT AT 139 - 147 ARGYLE STREET, NKIL 6005, 6035 R.P., 6036 R.P., 6037 R.P. & 6038 R.P.
 TITLE : SCHEDULE FOR Plenum Box At IN-SITU ALUM. WINDOW (T3: 1-20F)

DATE : 05-FEB-20 SCALE : 1:100
 DRAWN BY : MN CHECKED BY : DW

美特鋁質有限公司
MIDI ALUMINIUM FABRICATOR LTD.
 Units 6-8, Sunray Industrial Centre, 1/F
 610 Cha Kwo Ling Road, Kowloon
 Tel: 23489211-4 Fax: (852) 27727666
 DWG NO. : J852-SD-PB-4307 REV. : -

WINDOW MARK	W9 T3A
LOCATION	1/F~20/F Corridor AT TOWER 3 FLAT C
SECTION	50mm ALUM. SECTION
GLAZING	
QUANTITY	17
REMARKS	

ELEVATION

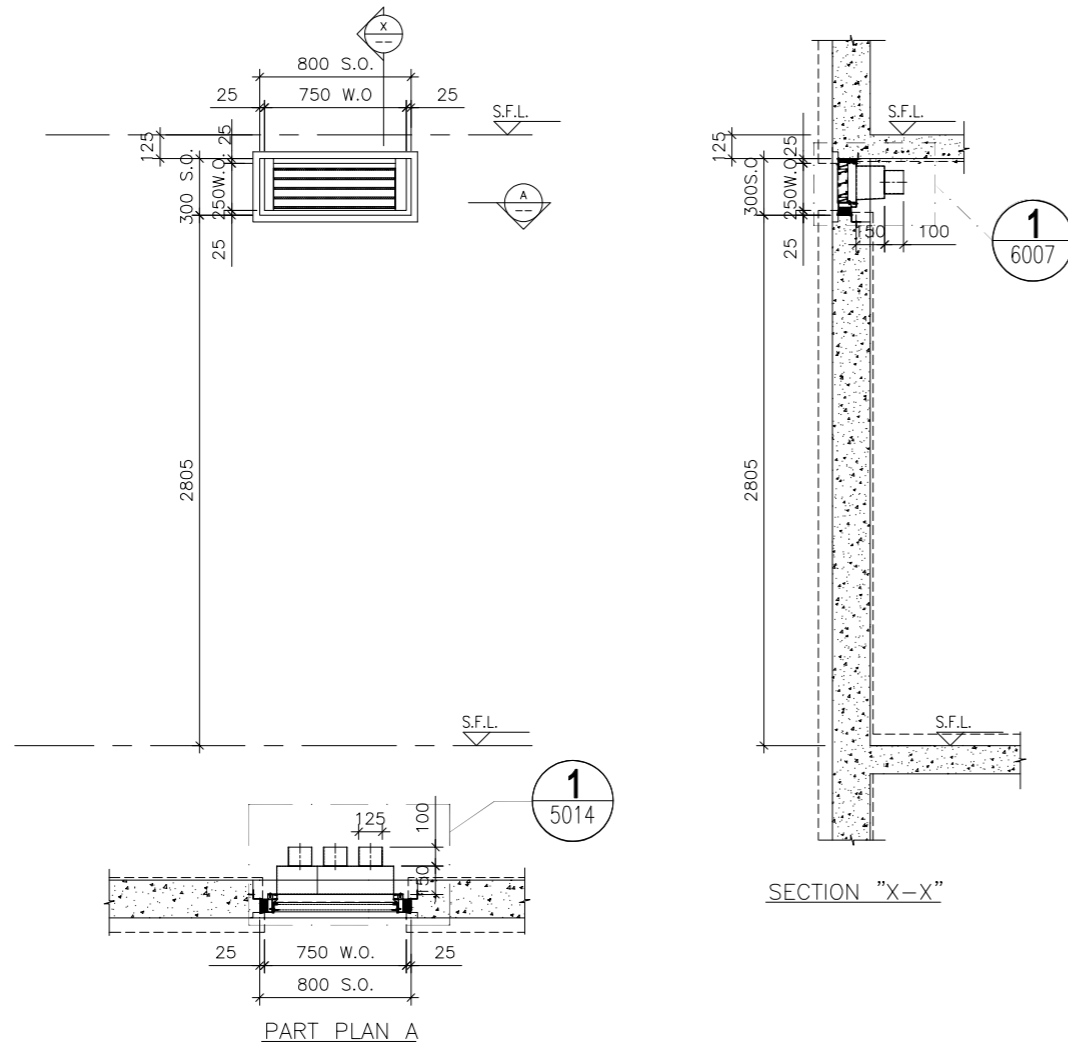

B.D. REF :

CLIENT :

ARCHITECT :
AGC DESIGN LTD
 1005, 14/F, Dynasty Plaza, 225, King's Road, North Point, Hong Kong
 Tel: (852) 27797812, Fax: (852) 27797133, Email: agc@agcdesign.com.hk

MAIN CONTRACTOR :
Gammon

STRUCTURAL ENGINEER :
ARUP

FACADE CONSULTANT:
MEINHARDT

NOTE :
 1. ALL DIMENSIONS ARE IN mm.
 2. ALL ELEVATIONS ARE VIEWED FROM OUTSIDE.
 3. ALL DIMENSIONS TO BE VERIFIED ON SITE BEFORE FABRICATION.

LEGEND :
 X1 --- DETAIL MARK NO.
 X001 --- REFER SHEET NO.
 1. F.F.L. --- FINISHED FLOOR LEVEL
 2. S.F.L. --- STRUCTURAL FLOOR LEVEL
 3. (R) --- REVERSED DETAIL
 4. ▲ --- FIXING LOCATION
 5. △ --- FIXING LUG LOCATION
 6. GLASS LEGEND
 GL01 --- 8mm+12mm AIR GAP+10mm THK. I.G.U.
 GL01c --- 8mm+12mm AIR GAP+12mm THK. I.G.U.
 GL02 --- 10mm THK. TEMPERED GLASS (SPANDREL GLASS)
 GL03 --- 6mm+12mm AIR GAP+6mm THK. I.G.U.
 GL04 --- 10mm THK. TEMPERED GLASS (PROTECTIVE BARRIER)
 GL05 --- 6mm+12mm AIR GAP+8mm THK. I.G.U.

NO.	DATE	REVISED	BY
-----	------	---------	----

JOB NO. : J-852
 PROJECT : PROPOSED RESIDENTIAL DEVELOPMENT AT 139 - 147 ARGYLE STREET, NKIL 6005, 6035 R.P., 6036 R.P., 6037 R.P. & 6038 R.P.
 TITLE : SCHEDULE FOR Plenum Box At IN-SITU ALUM. WINDOW (T3: 1-21F)

DATE : 05-FEB-20 SCALE : 1:100
 DRAWN BY : MN CHECKED BY : DW

美特鋁質有限公司
MIDI ALUMINIUM FABRICATOR LTD.
 Units 6-8, Sunray Industrial Centre, 1/F
 610 Cha Kwo Ling Road, Kowloon
 Tel: 23489211-4 Fax: (852) 27727666
 DWG NO. : J852-SD-PB-4308 REV. : -

WINDOW MARK	W9 T3A
LOCATION	21/F Corridor AT TOWER 3 FLAT C
SECTION	50mm ALUM. SECTION
GLAZING	
QUANTITY	1
REMARKS	

ELEVATION

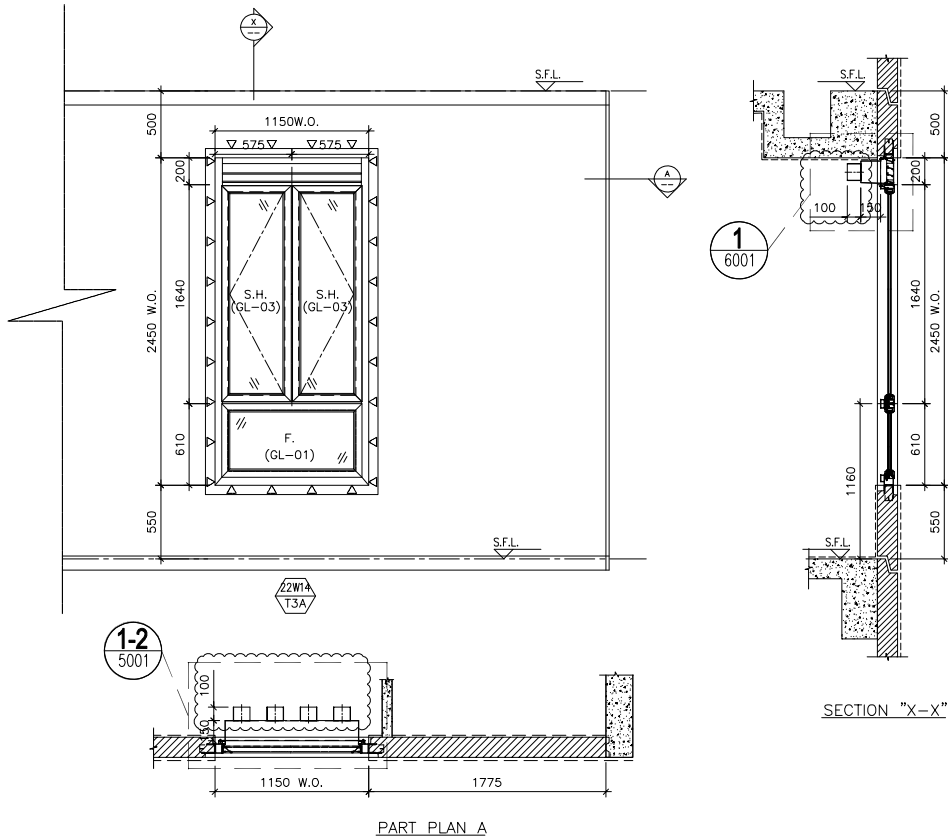

B.D. REF :
 CLIENT :
 ARCHITECT :
AGC DESIGN LTD

MAIN CONTRACTOR :
Gammon

STRUCTURAL ENGINEER :
ARUP

FAÇADE CONSULTANT :
MEINHARDT

NOTE :
 1. ALL DIMENSIONS ARE IN mm.
 2. ALL ELEVATIONS ARE VIEWED FROM OUTSIDE.
 3. ALL DIMENSIONS TO BE VERIFIED ON SITE BEFORE FABRICATION.

LEGEND :
 (X1) DETAIL MARK NO.
 (X001) REFER SHEET NO.
 1. F.F.L. -- FINISHED FLOOR LEVEL
 2. S.F.L. -- STRUCTURAL FLOOR LEVEL
 3. (R) -- REVERSED DETAIL
 4. ▲ -- FIXING LOCATION
 5. △ -- FIXING LUG LOCATION
 6. GLASS LEGEND
 GL01 -- 8mm+12mm AIR GAP+10mm THK. I.G.U.
 GL01α -- 8mm+9mm AIR GAP+12mm THK. I.G.U.
 GL03 -- 6mm+12mm AIR GAP+6mm THK. I.G.U.
 GL04 -- 10mm THK. TEMPERED GLASS (PROTECTIVE BARRIER)
 GL05 -- 6mm+12mm AIR GAP+8mm THK. I.G.U.

A	07/11/2020	REVISION SUBJECT TO ARCH COMMENT	ISSUED
NO.	DATE	REVISION	BY

JOB NO. : J-852
 PROJECT : PROPOSED RESIDENTIAL DEVELOPMENT AT 139 - 147 ARGYLE STREET, NKIL 6005, 6035 R.P., 6036 R.P., 6037 R.P. & 6038 R.P.

TITLE : SCHEDULE FOR Plenum Box AT TOWER 3 (22F)

DATE : 05-Dec-19 SCALE : 1:40
 DRAWN BY : MN CHECKED BY : DW

MIDI ALUMINIUM FABRICATOR LTD.
 Units 6-B, Sunray Industrial Centre, 1/F
 610 Cha Kwo Ling Road, Kowloon
 Tel: 23489211-4 Fax: (852) 2727666

DWG NO. : J852-SD-PB-4309 REV. : A

WINDOW MARK	
LOCATION	22/F EN.3 AT TOWER 3 FLAT A
SECTION	70mm ALUM. SECTION
GLAZING	GL-01, GL-03
QUANTITY	1
REMARKS	FAÇADE (PF-19)

ELEVATION

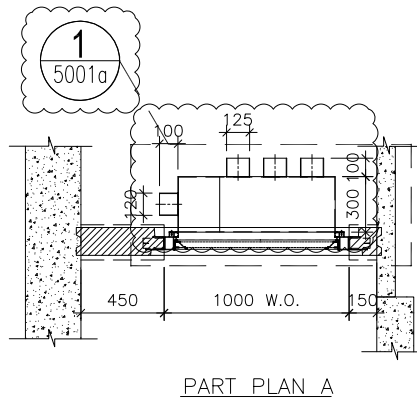
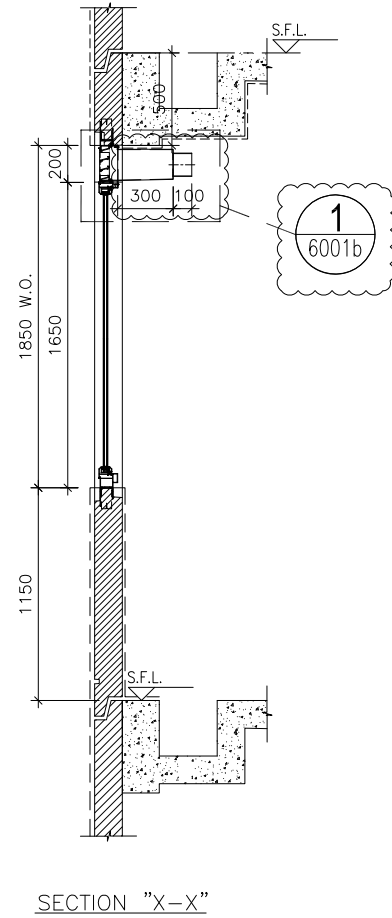
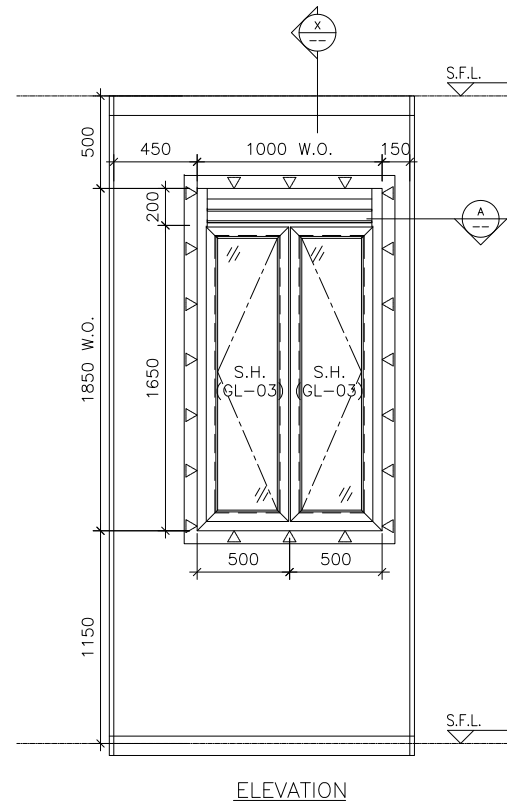

WINDOW MARK



LOCATION 22/F KIT. AT TOWER 3 FLAT C

SECTION 70mm ALUM. SECTION

GLAZING GL-03

QUANTITY 1

REMARKS FACADE (PF-25)

B.D. REF :

CLIENT :

ARCHITECT :

AGC
DESIGN LTD

MAIN CONTRACTOR :

Gammon

STRUCTURAL ENGINEER :

ARUP

FACADE CONSULTANT:

MEINHARDT

NOTE :

1. ALL DIMENSIONS ARE IN mm.
2. ALL ELEVATIONS ARE VIEWED FROM OUTSIDE.
3. ALL DIMENSIONS TO BE VERIFIED ON SITE BEFORE FABRICATION.

LEGEND :

- x1 --- DETAIL MARK NO.
- x001 --- REFER SHEET NO.

1. F.F.L. --- FINISHED FLOOR LEVEL
2. S.F.L. --- STRUCTURAL FLOOR LEVEL
3. (R) --- REVERSED DETAIL
4. ▲ --- FIXING LOCATION
5. △ --- FIXING LUG LOCATION

6. GLASS LEGEND

- GL01 --- 8mm+12mm AIR GAP+10mm THK. I.G.U.
- GL01a --- 8mm+9mm AIR GAP+12mm THK. I.G.U.
- GL03 --- 6mm+12mm AIR GAP+6mm THK. I.G.U.
- GL04 --- 10mm THK. TEMPERED GLASS (PROTECTIVE BARRIER)
- GL05 --- 6mm+12mm AIR GAP+8mm THK. I.G.U.

NO.	DATE	REVISION	BY
A	09/12/2020	REVISION SUBJECT TO ARCH.COMMENT	Ivan

JOB NO. : J-852

PROJECT :
PROPOSED RESIDENTIAL DEVELOPMENT
AT 139 - 147 ARGYLE STREET,
NKIL 6005, 6035 R.P., 6036 R.P.,
6037 R.P. & 6038 R.P.

TITLE :
SCHEDULE FOR Plenum Box
AT TOWER 3 (22F)

DATE : 05-Dec-19 SCALE : 1:40

DRAWN BY : MN CHECKED BY : DW

美特鋁質有限公司
MIDI ALUMINIUM FABRICATOR LTD.
Units 6-8, Sunray Industrial Centre, 1/F
610 Cha Kwo Ling Road, Kowloon
Tel:23489211-4 Fax:(852)2727666

DWG NO. : J852-SD-PB-4310 REV. : A

ELEVATION

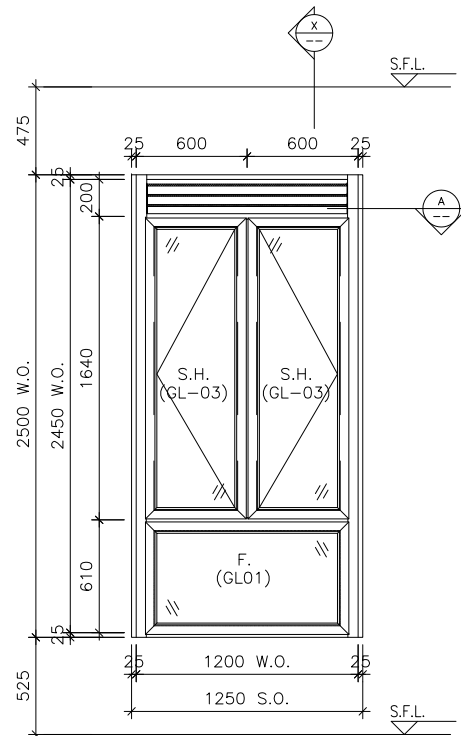

ELEVATION

1
5011

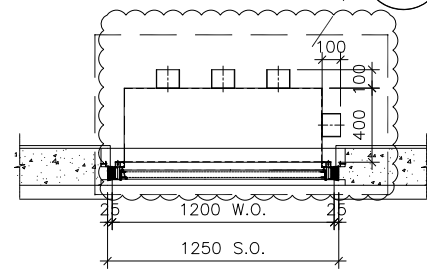

PART PLAN A

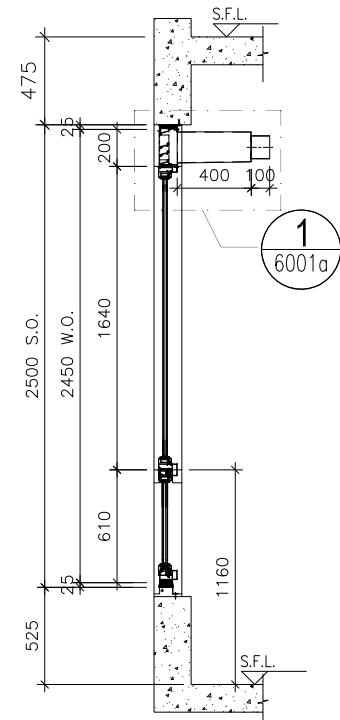

SECTION "X-X"

WINDOW MARK



LOCATION 22/F BATH AT TOWER 3 FLAT A

SECTION 70mm ALUM. SECTION

GLAZING GL-01, GL-03

QUANTITY 1

REMARKS

B.D. REF :

CLIENT :

ARCHITECT :

AGC
DESIGN LTD

MAIN CONTRACTOR :

Gammon

STRUCTURAL ENGINEER :

ARUP

FACADE CONSULTANT:

MEINHARDT

NOTE :

1. ALL DIMENSIONS ARE IN mm.
2. ALL ELEVATIONS ARE VIEWED FROM OUTSIDE.
3. ALL DIMENSIONS TO BE VERIFIED ON SITE BEFORE FABRICATION.

LEGEND :

- (x1) — DETAIL MARK NO.
- (x001) — REFER SHEET NO.

1. F.F.L. -- FINISHED FLOOR LEVEL
2. S.F.L. -- STRUCTURAL FLOOR LEVEL
3. (R) -- REVERSED DETAIL

NO.	DATE	REVISION	BY
A	09/12/2020	REVISION SUBJECT TO ARCH.COMMENT	Ivan

JOB NO. : J-852

PROJECT :
PROPOSED RESIDENTIAL DEVELOPMENT
AT 139 - 147 ARGYLE STREET,
NKIL 6005, 6035 R.P., 6036 R.P.,
6037 R.P. & 6038 R.P.

TITLE :
SCHEDULE FOR Plenum Box
At IN-SITU ALUM. WINDOW (T3-22F)

DATE : 05-FEB-20 SCALE : 1:100

DRAWN BY : MN CHECKED BY : DW

美特鋁質有限公司
MIDI ALUMINIUM FABRICATOR LTD.
Units 6-8, Sunray Industrial Centre, 1/F
610 Cha Kwo Ling Road, Kowloon
Tel:23489211-4 Fax:(852)2727666

DWG NO. : J852-SD-PB-4311 REV. : A

ELEVATION

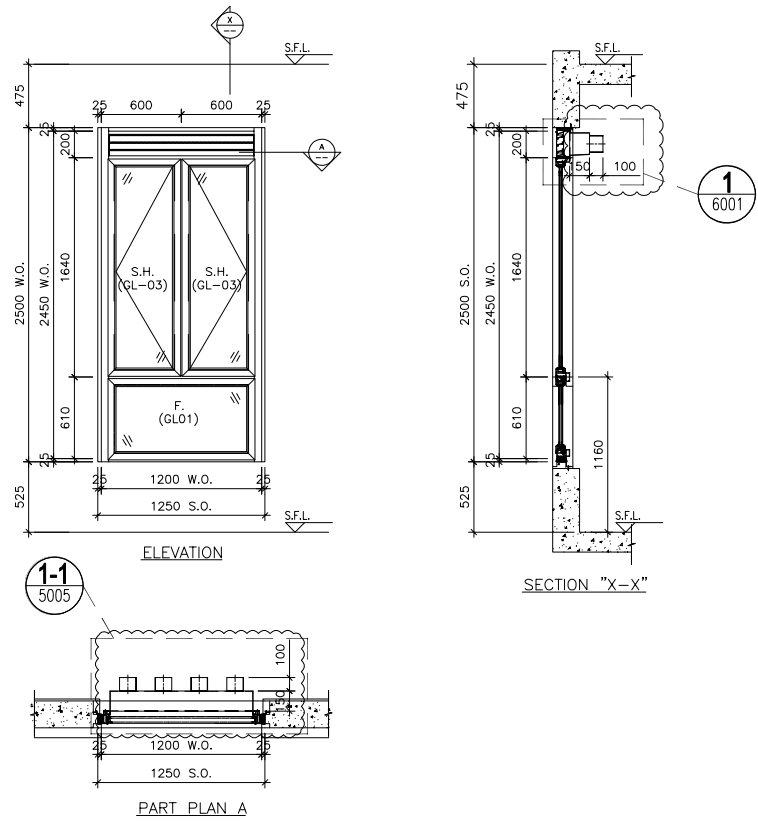

B.D. REF :

CLIENT :

ARCHITECT :
AGC DESIGN LTD

MAIN CONTRACTOR :
Gammon

STRUCTURAL ENGINEER :
ARUP

FAÇADE CONSULTANT:
MEINHARDT

NOTE:
 1. ALL DIMENSIONS ARE IN mm.
 2. ALL ELEVATIONS ARE VIEWED FROM OUTSIDE.
 3. ALL DIMENSIONS TO BE VERIFIED ON SITE BEFORE FABRICATION.

LEGEND :
 (X1) --- DETAIL MARK NO.
 (X001) --- REFER SHEET NO.
 1. F.F.L. --- FINISHED FLOOR LEVEL
 2. S.F.L. --- STRUCTURAL FLOOR LEVEL
 3. (R) --- REVERSED DETAIL

A	07/11/2020	REVISION SUBJECT TO ARCH COMMENT	ISSUE
NO.	DATE	REVISION	BY

JOB NO. : J-852
 PROJECT : PROPOSED RESIDENTIAL DEVELOPMENT AT 139 - 147 ARGYLE STREET, NKIL 6005, 6035 R.P., 6036 R.P., 6037 R.P. & 6038 R.P.

TITLE : SCHEDULE FOR Plenum Box At IN-SITU ALUM. WINDOW (T3-22F)

DATE : 05-FEB-20 SCALE : 1:100
 DRAWN BY : MN CHECKED BY : DW

MIDI ALUMINIUM FABRICATOR LTD.
 Units 6-B, Sunray Industrial Centre, 1/F
 610 Cha Kwo Ling Road, Kowloon
 Tel:23489211-4 Fax:(852)2727666

DWG NO. : J852-SD-PB-4312 REV. : A

WINDOW MARK	$\frac{22WB}{T3A}$
LOCATION	22/F EN. B 3 AT TOWER 3 FLAT A
SECTION	70mm ALUM. SECTION
GLAZING	GL-01, GL-03
QUANTITY	1
REMARKS	

ELEVATION

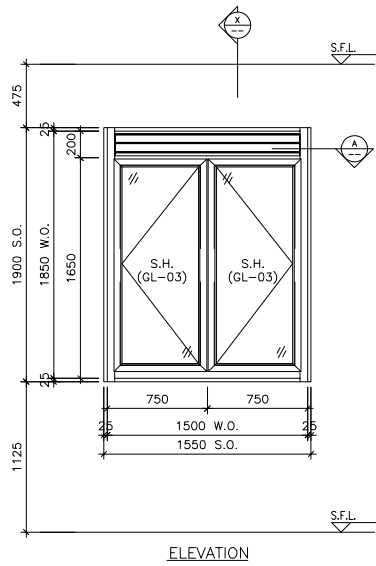

ELEVATION

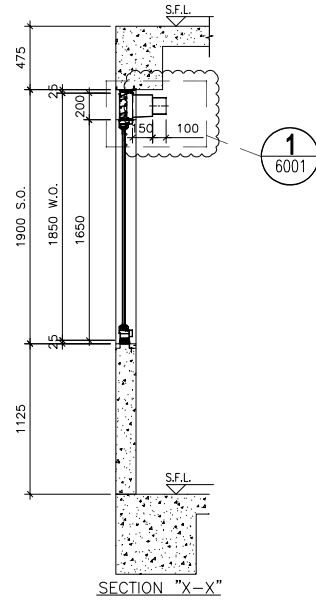

SECTION "X-X"

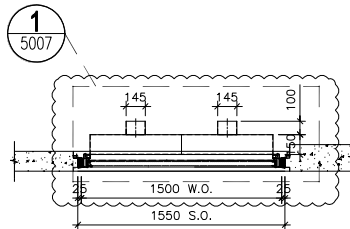

PART PLAN A

B.D. REF :

CLIENT :

ARCHITECT :
AGC DESIGN LTD

MAIN CONTRACTOR :
Gammon

STRUCTURAL ENGINEER :
ARUP

FAÇADE CONSULTANT:
MEINHARDT

NOTE :
1. ALL DIMENSIONS ARE IN mm.
2. ALL ELEVATIONS ARE VIEWED FROM OUTSIDE.
3. ALL DIMENSIONS TO BE VERIFIED ON SITE BEFORE FABRICATION.

LEGEND :
 (X1) --- DETAIL MARK NO.
 (X001) --- REFER SHEET NO.
 1. F.F.L. --- FINISHED FLOOR LEVEL
 2. S.F.L. --- STRUCTURAL FLOOR LEVEL
 3. (⊗) --- REVERSED DETAIL

No.	DATE	REVISION	BY
A	07/11/2020	REVISION SUBJECT TO ARCH COMMENT	xxxx

JOB NO. : J-852
 PROJECT : PROPOSED RESIDENTIAL DEVELOPMENT AT 139 - 147 ARGYLE STREET, NKIL 6005, 6035 R.P., 6036 R.P., 6037 R.P. & 6038 R.P.

TITLE : SCHEDULE FOR Plenum Box At IN-SITU ALUM. WINDOW (T3-22F)

DATE : 05-FEB-20 SCALE : 1:100
 DRAWN BY : MN CHECKED BY : DW

MIDI ALUMINIUM FABRICATOR LTD.
 Units 6-B, Sunray Industrial Centre, 1/F
 610 Cha Kwo Ling Road, Kowloon
 Tel: 23489211-4 Fax: (852) 27272666

DWG NO. : J852-SD-PB-4313 REV. : A

WINDOW MARK	$\frac{22W9x}{T3A}$
LOCATION	22/F KIT. AT TOWER 3 FLAT A
SECTION	70mm ALUM. SECTION
GLAZING	GL-03
QUANTITY	1
REMARKS	

ELEVATION

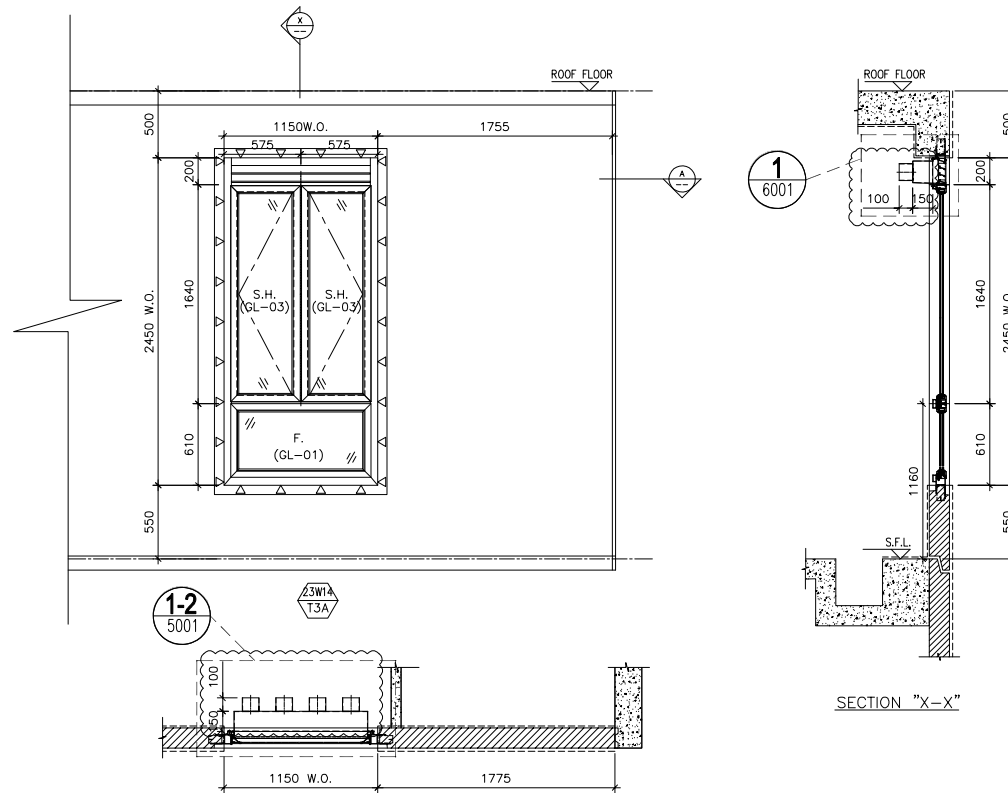

B.D. REF :

CLIENT :

ARCHITECT :

AGC DESIGN LTD

MAIN CONTRACTOR :

Gammon

STRUCTURAL ENGINEER :

ARUP

FAÇADE CONSULTANT:

MEINHARDT

NOTE :

1. ALL DIMENSIONS ARE IN mm.
2. ALL ELEVATIONS ARE VIEWED FROM OUTSIDE.
3. ALL DIMENSIONS TO BE VERIFIED ON SITE BEFORE FABRICATION.

LEGEND :

(X1) -- DETAIL MARK NO.
 (X001) -- REFER SHEET NO.

1. F.F.L. -- FINISHED FLOOR LEVEL
2. S.F.L. -- STRUCTURAL FLOOR LEVEL
3. (R) -- REVERSED DETAIL
4. (▲) -- FIXING LOCATION
5. (△) -- FIXING LUG LOCATION
6. GLASS LEGEND

GL01 -- 8mm+12mm AIR GAP+10mm THK. I.G.U.
 GL01a -- 8mm+9mm AIR GAP+12mm THK. I.G.U.
 GL02 -- 10mm THK. TEMPERED GLASS (SPANDREL GLASS)
 GL03 -- 6mm+12mm AIR GAP+6mm THK. I.G.U.
 GL04 -- 10mm THK. TEMPERED GLASS (PROTECTIVE BARRIER)
 GL05 -- 6mm+12mm AIR GAP+8mm THK. I.G.U.

No.	DATE	REVISION	COMMENT	BY
A	07/11/2020		REVISION SUBJECT TO ARCH.COMMENT	

JOB NO. : J-852

PROJECT : PROPOSED RESIDENTIAL DEVELOPMENT
 AT 139 - 147 ARGYLE STREET,
 NKIL 6005, 6035 R.P., 6036 R.P.,
 6037 R.P. & 6038 R.P.

TITLE : SCHEDULE FOR Plenum Box
 AT TOWER 3 (23F)

DATE : 05-Dec-19 SCALE : 1:40

DRAWN BY : MN CHECKED BY : DW

MIDI ALUMINIUM FABRICATOR LTD.

Units 6-B, Sunray Industrial Centre, 1/F
 610 Cha Kwo Ling Road, Kowloon
 Tel: 23489211-4 Fax: (852) 27272666

DWG NO. : J852-SD-PB-4314 REV. : A

WINDOW MARK	
LOCATION	23/F M.B AT TOWER 3 FLAT A
SECTION	70mm ALUM. SECTION
GLAZING	GL-01, GL-03
QUANTITY	1
REMARKS	FAÇADE (PF-19)

ELEVATION

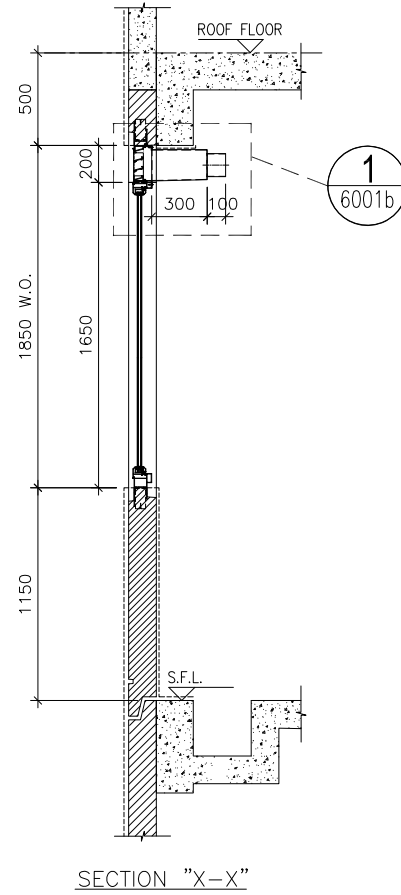
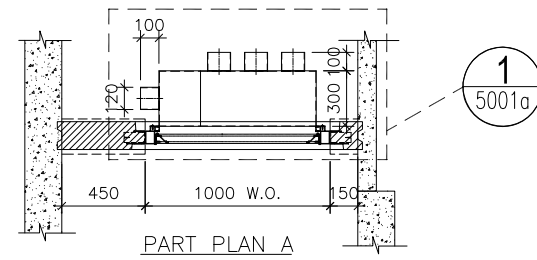
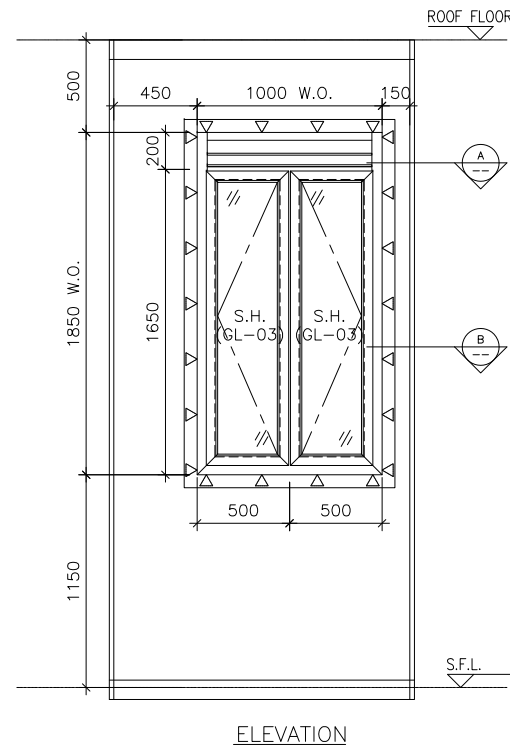

WINDOW MARK



LOCATION 23/F KIT. AT TOWER 3 FLAT C

SECTION 70mm ALUM. SECTION

GLAZING GL-03

QUANTITY 1

REMARKS FACADE (PF-25)

B.D. REF :

CLIENT :

ARCHITECT :

AGC
DESIGN LTD

MAIN CONTRACTOR :

Gammon

STRUCTURAL ENGINEER :

ARUP

FACADE CONSULTANT:

MEINHARDT

NOTE :

1. ALL DIMENSIONS ARE IN mm.
2. ALL ELEVATIONS ARE VIEWED FROM OUTSIDE.
3. ALL DIMENSIONS TO BE VERIFIED ON SITE BEFORE FABRICATION.

LEGEND :

- x1 --- DETAIL MARK NO.
- x001 --- REFER SHEET NO.

1. F.F.L. --- FINISHED FLOOR LEVEL
2. S.F.L. --- STRUCTURAL FLOOR LEVEL
3. (R) --- REVERSED DETAIL
4. ▲ --- FIXING LOCATION
5. △ --- FIXING LUG LOCATION

GLASS LEGEND

- GL01 --- 8mm+12mm AIR GAP+10mm THK. I.G.U.
- GL01a --- 8mm+9mm AIR GAP+12mm THK. I.G.U.
- GL02 --- 10mm THK. TEMPERED GLASS (SPANDREL GLASS)
- GL03 --- 6mm+12mm AIR GAP+6mm THK. I.G.U.
- GL04 --- 10mm THK. TEMPERED GLASS (PROTECTIVE BARRIER)
- GL05 --- 6mm+12mm AIR GAP+8mm THK. I.G.U.

NO.	DATE	REVISED	BY
JOB NO. : J-852			
PROJECT : PROPOSED RESIDENTIAL DEVELOPMENT AT 139 - 147 ARGYLE STREET, NKIL 6005, 6035 R.P., 6036 R.P., 6037 R.P. & 6038 R.P.			
TITLE : SCHEDULE FOR Plenum Box AT TOWER 3 (23F)			
DATE : 05-Dec-19		SCALE : 1:40	
DRAWN BY : MN		CHECKED BY : DW	
<p>美特鋁質有限公司 MIDI ALUMINIUM FABRICATOR LTD. Units 6-8, Sunray Industrial Centre, 1/F 610 Cha Kwo Ling Road, Kowloon Tel:23489211-4 Fax:(852)2727666</p>			
DWG NO. : J852-SD-PB-4315		REV. : -	

JOB NO. : J-852

PROJECT : PROPOSED RESIDENTIAL DEVELOPMENT AT 139 - 147 ARGYLE STREET, NKIL 6005, 6035 R.P., 6036 R.P., 6037 R.P. & 6038 R.P.

TITLE : SCHEDULE FOR Plenum Box AT TOWER 3 (23F)

DATE : 05-Dec-19

SCALE : 1:40

DRAWN BY : MN

CHECKED BY : DW

美特鋁質有限公司
MIDI ALUMINIUM FABRICATOR LTD.
Units 6-8, Sunray Industrial Centre, 1/F
610 Cha Kwo Ling Road, Kowloon
Tel:23489211-4 Fax:(852)2727666

DWG NO. : J852-SD-PB-4315

REV. : -

ELEVATION

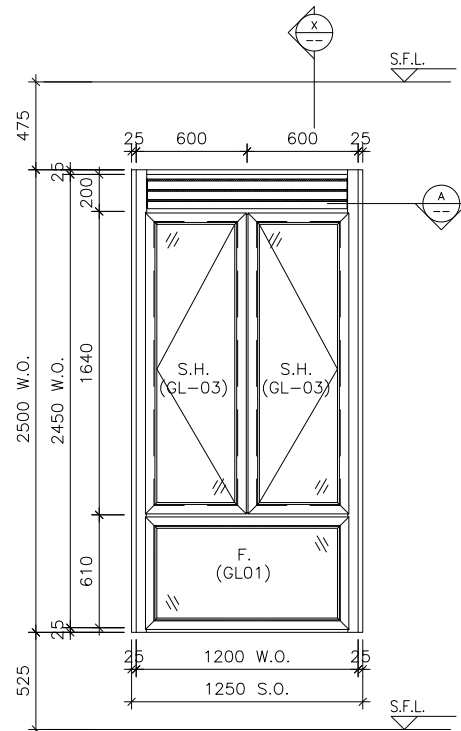

ELEVATION

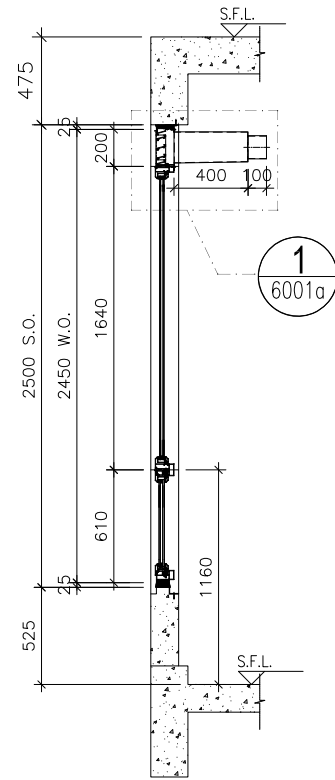

SECTION "X-X"

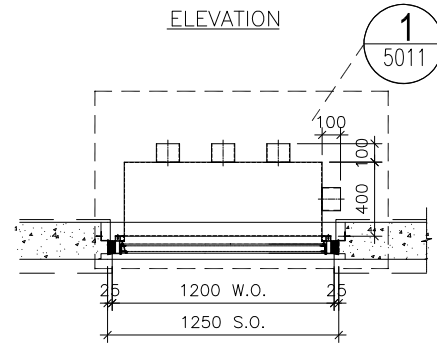

PART PLAN A

WINDOW MARK



LOCATION 23/F BATH AT TOWER 3 FLAT A

SECTION 70mm ALUM. SECTION

GLAZING GL-01, GL-03

QUANTITY 1

REMARKS

B.D. REF :

CLIENT :

ARCHITECT :

AGC
DESIGN LTD

MAIN CONTRACTOR :

Gammon

STRUCTURAL ENGINEER :

ARUP

FACADE CONSULTANT:

MEINHARDT

NOTE :

1. ALL DIMENSIONS ARE IN mm.
2. ALL ELEVATIONS ARE VIEWED FROM OUTSIDE.
3. ALL DIMENSIONS TO BE VERIFIED ON SITE BEFORE FABRICATION.

LEGEND :

- (X1) --- DETAIL MARK NO.
- (X001) --- REFER SHEET NO.

1. F.F.L. -- FINISHED FLOOR LEVEL
2. S.F.L. -- STRUCTURAL FLOOR LEVEL
3. (R) -- REVERSED DETAIL

NO.	DATE	REVISED	BY

JOB NO. : J-852

PROJECT :
PROPOSED RESIDENTIAL DEVELOPMENT
AT 139 - 147 ARGYLE STREET,
NKIL 6005, 6035 R.P., 6036 R.P.,
6037 R.P. & 6038 R.P.

TITLE :
SCHEDULE FOR Plenum Box
At IN-SITU ALUM. WINDOW (T3-23F)

DATE : 05-FEB-20 SCALE : 1:100

DRAWN BY : MN CHECKED BY : DW

美特鋁質有限公司
MIDI ALUMINIUM FABRICATOR LTD.
Units 6-8, Sunray Industrial Centre, 1/F
610 Cha Kwo Ling Road, Kowloon
Tel:23489211-4 Fax:(852)2727666

DWG NO. : J852-SD-PB-4316 REV. : -

ELEVATION

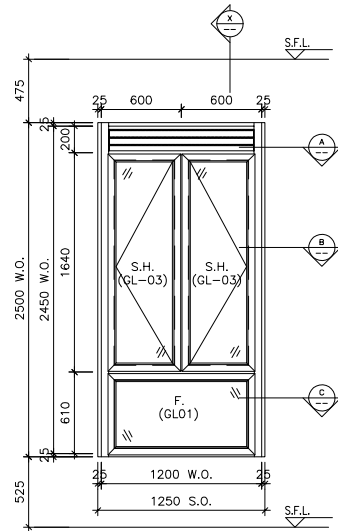

ELEVATION

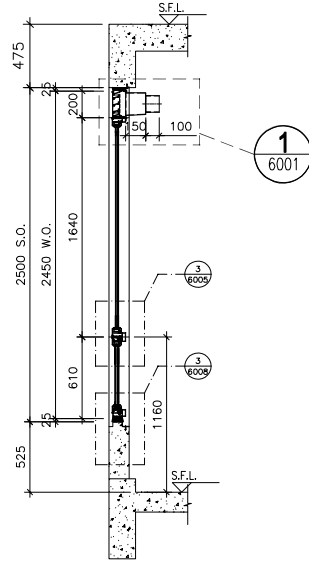

SECTION "X-X"

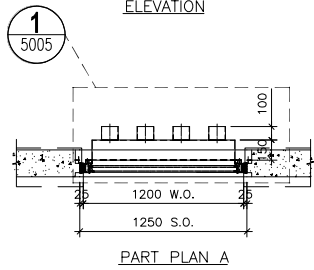

PART PLAN A

B.D. REF :

CLIENT :

ARCHITECT :
AGC DESIGN LTD

MAIN CONTRACTOR :
Gammon

STRUCTURAL ENGINEER :
ARUP

FACADE CONSULTANT:
MEINHARDT

NOTE :
 1. ALL DIMENSIONS ARE IN mm.
 2. ALL ELEVATIONS ARE VIEWED FROM OUTSIDE.
 3. ALL DIMENSIONS TO BE VERIFIED ON SITE BEFORE FABRICATION.

LEGEND :
 (X1) --- DETAIL MARK NO.
 (X001) --- REFER SHEET NO.
 1. F.F.L. --- FINISHED FLOOR LEVEL
 2. S.F.L. --- STRUCTURAL FLOOR LEVEL
 3. (R) --- REVERSED DETAIL

NO.	DATE	REVISED	BY
-----	------	---------	----

JOB NO. : J-852
 PROJECT : PROPOSED RESIDENTIAL DEVELOPMENT AT 139 - 147 ARGYLE STREET, NKIL 6005, 6035 R.P., 6036 R.P., 6037 R.P. & 6038 R.P.

TITLE : SCHEDULE FOR Plenum Box At IN-SITU ALUM. WINDOW (T3-23F)

DATE : 05-FEB-20 SCALE : 1:100
 DRAWN BY : MN CHECKED BY : DW

MIDI ALUMINIUM FABRICATOR LTD.
 Units 6-B, Sunray Industrial Centre, 1/F
 610 Cha Kwo Ling Road, Kowloon
 Tel:23489211-4 Fax:(852)2727666

DWG NO. : J852-SD-PB-4317 REV. : -

WINDOW MARK	△3WB ▽T3A
LOCATION	23/F EN. B 3 AT TOWER 3 FLAT A
SECTION	70mm ALUM. SECTION
GLAZING	GL-01, GL-03
QUANTITY	1
REMARKS	

ELEVATION

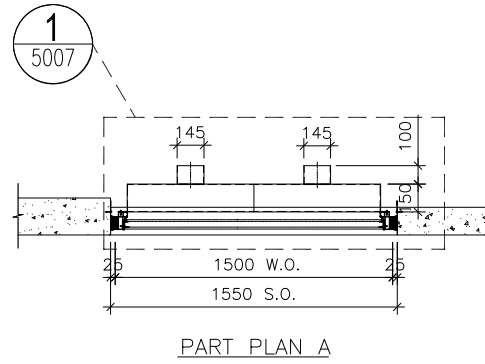
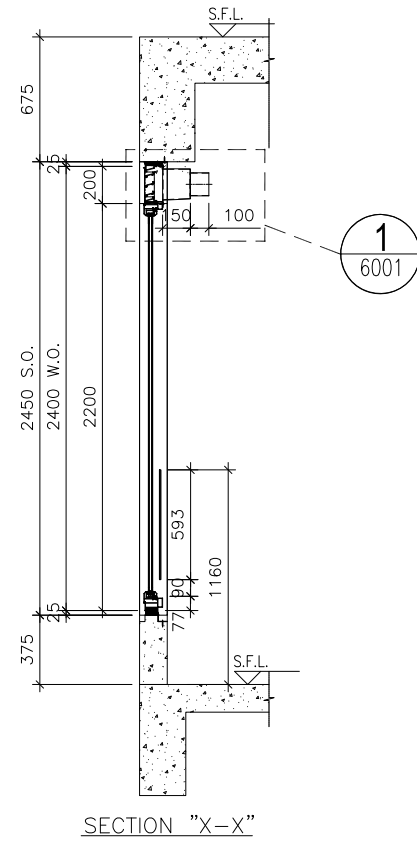
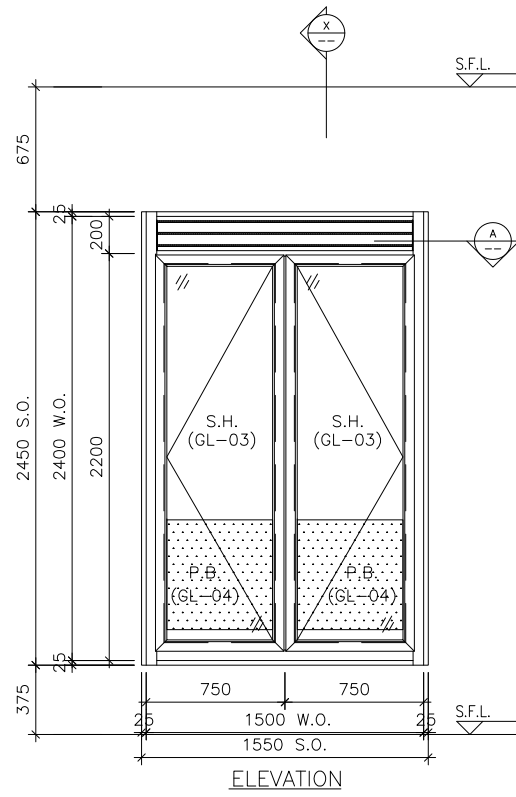

WINDOW MARK	
LOCATION	23/F KIT. AT TOWER 3 FLAT A
SECTION	70mm ALUM. SECTION
GLAZING	GL-03
QUANTITY	1
REMARKS	

B.D. REF :

CLIENT :

ARCHITECT :
AGC DESIGN LTD
 110, 112, 114, 116, 118, 120, 122, 124, 126, 128, 130, 132, 134, 136, 138, 140, 142, 144, 146, 148, 150, 152, 154, 156, 158, 160, 162, 164, 166, 168, 170, 172, 174, 176, 178, 180, 182, 184, 186, 188, 190, 192, 194, 196, 198, 200, 202, 204, 206, 208, 210, 212, 214, 216, 218, 220, 222, 224, 226, 228, 230, 232, 234, 236, 238, 240, 242, 244, 246, 248, 250, 252, 254, 256, 258, 260, 262, 264, 266, 268, 270, 272, 274, 276, 278, 280, 282, 284, 286, 288, 290, 292, 294, 296, 298, 300, 302, 304, 306, 308, 310, 312, 314, 316, 318, 320, 322, 324, 326, 328, 330, 332, 334, 336, 338, 340, 342, 344, 346, 348, 350, 352, 354, 356, 358, 360, 362, 364, 366, 368, 370, 372, 374, 376, 378, 380, 382, 384, 386, 388, 390, 392, 394, 396, 398, 400, 402, 404, 406, 408, 410, 412, 414, 416, 418, 420, 422, 424, 426, 428, 430, 432, 434, 436, 438, 440, 442, 444, 446, 448, 450, 452, 454, 456, 458, 460, 462, 464, 466, 468, 470, 472, 474, 476, 478, 480, 482, 484, 486, 488, 490, 492, 494, 496, 498, 500, 502, 504, 506, 508, 510, 512, 514, 516, 518, 520, 522, 524, 526, 528, 530, 532, 534, 536, 538, 540, 542, 544, 546, 548, 550, 552, 554, 556, 558, 560, 562, 564, 566, 568, 570, 572, 574, 576, 578, 580, 582, 584, 586, 588, 590, 592, 594, 596, 598, 600, 602, 604, 606, 608, 610, 612, 614, 616, 618, 620, 622, 624, 626, 628, 630, 632, 634, 636, 638, 640, 642, 644, 646, 648, 650, 652, 654, 656, 658, 660, 662, 664, 666, 668, 670, 672, 674, 676, 678, 680, 682, 684, 686, 688, 690, 692, 694, 696, 698, 700, 702, 704, 706, 708, 710, 712, 714, 716, 718, 720, 722, 724, 726, 728, 730, 732, 734, 736, 738, 740, 742, 744, 746, 748, 750, 752, 754, 756, 758, 760, 762, 764, 766, 768, 770, 772, 774, 776, 778, 780, 782, 784, 786, 788, 790, 792, 794, 796, 798, 800, 802, 804, 806, 808, 810, 812, 814, 816, 818, 820, 822, 824, 826, 828, 830, 832, 834, 836, 838, 840, 842, 844, 846, 848, 850, 852, 854, 856, 858, 860, 862, 864, 866, 868, 870, 872, 874, 876, 878, 880, 882, 884, 886, 888, 890, 892, 894, 896, 898, 900, 902, 904, 906, 908, 910, 912, 914, 916, 918, 920, 922, 924, 926, 928, 930, 932, 934, 936, 938, 940, 942, 944, 946, 948, 950, 952, 954, 956, 958, 960, 962, 964, 966, 968, 970, 972, 974, 976, 978, 980, 982, 984, 986, 988, 990, 992, 994, 996, 998, 1000

MAIN CONTRACTOR :
Gammon

STRUCTURAL ENGINEER :
ARUP

FACADE CONSULTANT:
MEINHARDT

NOTE :

1. ALL DIMENSIONS ARE IN mm.
2. ALL ELEVATIONS ARE VIEWED FROM OUTSIDE.
3. ALL DIMENSIONS TO BE VERIFIED ON SITE BEFORE FABRICATION.

LEGEND :

— DETAIL MARK NO.
 — REFER SHEET NO.

1. F.F.L. -- FINISHED FLOOR LEVEL
2. S.F.L. -- STRUCTURAL FLOOR LEVEL
3. -- REVERSED DETAIL

NO.	DATE	REVISED	BY
JOB NO. : J-852			
PROJECT : PROPOSED RESIDENTIAL DEVELOPMENT AT 139 - 147 ARGYLE STREET, NKIL 6005, 6035 R.P., 6036 R.P., 6037 R.P. & 6038 R.P.			
TITLE : SCHEDULE FOR Plenum Box At IN-SITU ALUM. WINDOW (T3-23F)			
DATE : 05-FEB-20		SCALE : 1:100	
DRAWN BY : MN		CHECKED BY : DW	
美特鋁質有限公司 MIDI ALUMINIUM FABRICATOR LTD. Units 6-8, Sunray Industrial Centre, 1/F 610 Cha Kwo Ling Road, Kowloon Tel:23489211-4 Fax:(852)2727666			
DWG NO. : J852-SD-PB-4318			REV. : -

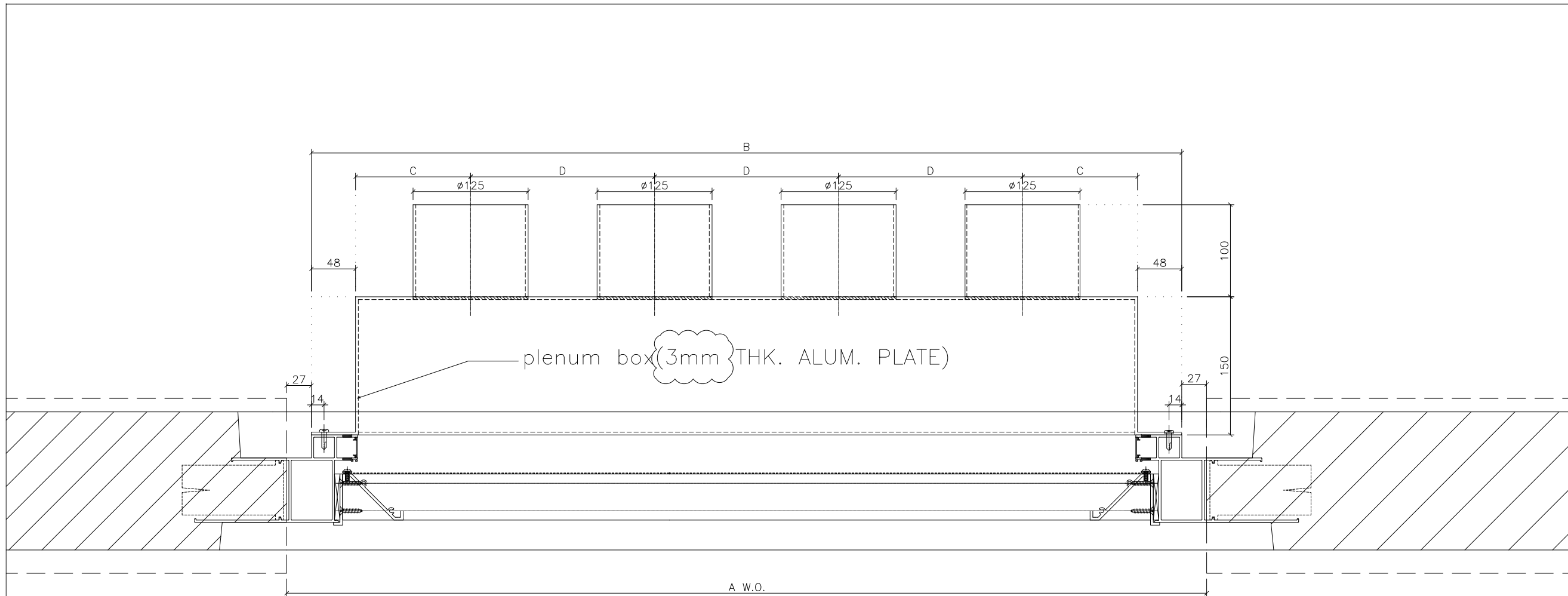

1 HORIZONTAL DETAIL OUTSIDE

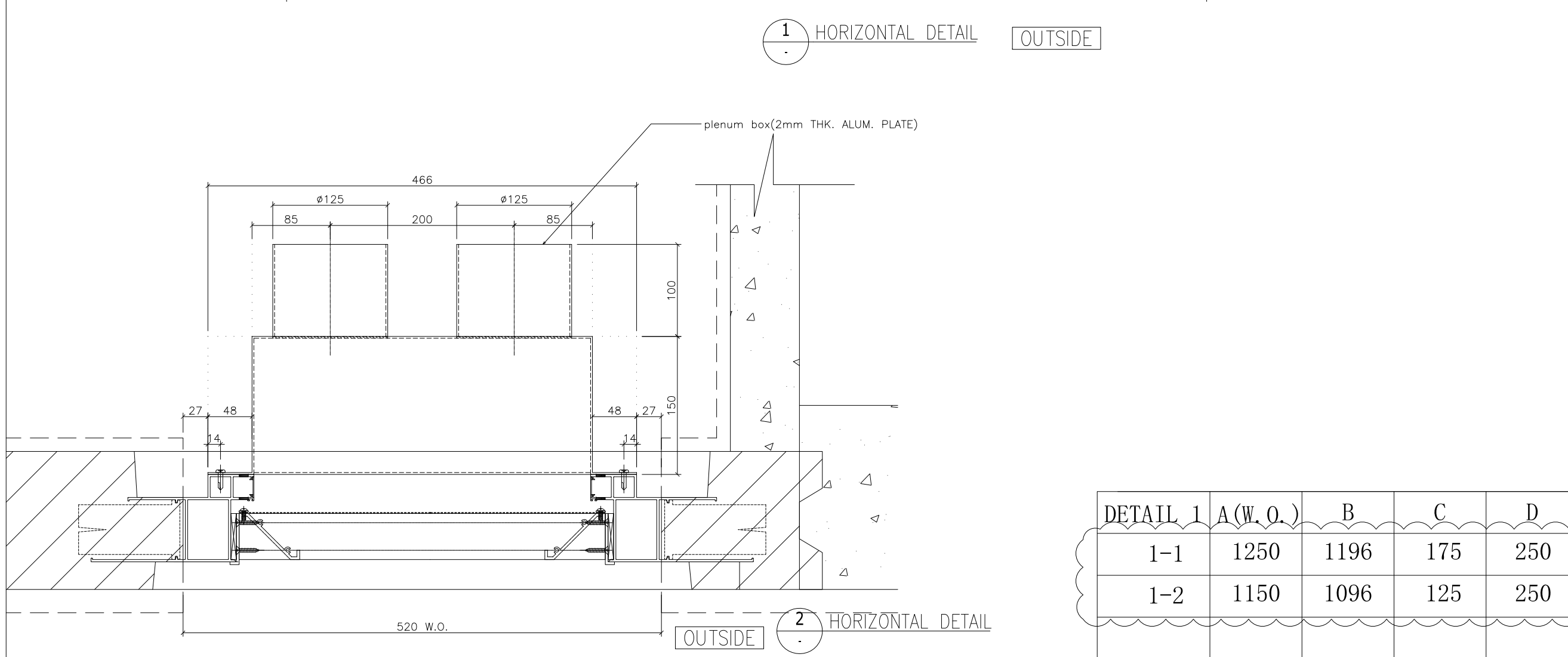

2 HORIZONTAL DETAIL OUTSIDE

DETAIL 1	A(W.O.)	B	C	D
1-1	1250	1196	175	250
1-2	1150	1096	125	250

B.D. REF :

CLIENT :

ARCHITECT :
AGC DESIGN LTD
 110, 112, 114, 116, 118, 120, 122, 124, 126, 128, 130, 132, 134, 136, 138, 140, 142, 144, 146, 148, 150, 152, 154, 156, 158, 160, 162, 164, 166, 168, 170, 172, 174, 176, 178, 180, 182, 184, 186, 188, 190, 192, 194, 196, 198, 200, 202, 204, 206, 208, 210, 212, 214, 216, 218, 220, 222, 224, 226, 228, 230, 232, 234, 236, 238, 240, 242, 244, 246, 248, 250, 252, 254, 256, 258, 260, 262, 264, 266, 268, 270, 272, 274, 276, 278, 280, 282, 284, 286, 288, 290, 292, 294, 296, 298, 300, 302, 304, 306, 308, 310, 312, 314, 316, 318, 320, 322, 324, 326, 328, 330, 332, 334, 336, 338, 340, 342, 344, 346, 348, 350, 352, 354, 356, 358, 360, 362, 364, 366, 368, 370, 372, 374, 376, 378, 380, 382, 384, 386, 388, 390, 392, 394, 396, 398, 400, 402, 404, 406, 408, 410, 412, 414, 416, 418, 420, 422, 424, 426, 428, 430, 432, 434, 436, 438, 440, 442, 444, 446, 448, 450, 452, 454, 456, 458, 460, 462, 464, 466, 468, 470, 472, 474, 476, 478, 480, 482, 484, 486, 488, 490, 492, 494, 496, 498, 500, 502, 504, 506, 508, 510, 512, 514, 516, 518, 520, 522, 524, 526, 528, 530, 532, 534, 536, 538, 540, 542, 544, 546, 548, 550, 552, 554, 556, 558, 560, 562, 564, 566, 568, 570, 572, 574, 576, 578, 580, 582, 584, 586, 588, 590, 592, 594, 596, 598, 600, 602, 604, 606, 608, 610, 612, 614, 616, 618, 620, 622, 624, 626, 628, 630, 632, 634, 636, 638, 640, 642, 644, 646, 648, 650, 652, 654, 656, 658, 660, 662, 664, 666, 668, 670, 672, 674, 676, 678, 680, 682, 684, 686, 688, 690, 692, 694, 696, 698, 700, 702, 704, 706, 708, 710, 712, 714, 716, 718, 720, 722, 724, 726, 728, 730, 732, 734, 736, 738, 740, 742, 744, 746, 748, 750, 752, 754, 756, 758, 760, 762, 764, 766, 768, 770, 772, 774, 776, 778, 780, 782, 784, 786, 788, 790, 792, 794, 796, 798, 800, 802, 804, 806, 808, 810, 812, 814, 816, 818, 820, 822, 824, 826, 828, 830, 832, 834, 836, 838, 840, 842, 844, 846, 848, 850, 852, 854, 856, 858, 860, 862, 864, 866, 868, 870, 872, 874, 876, 878, 880, 882, 884, 886, 888, 890, 892, 894, 896, 898, 900, 902, 904, 906, 908, 910, 912, 914, 916, 918, 920, 922, 924, 926, 928, 930, 932, 934, 936, 938, 940, 942, 944, 946, 948, 950, 952, 954, 956, 958, 960, 962, 964, 966, 968, 970, 972, 974, 976, 978, 980, 982, 984, 986, 988, 990, 992, 994, 996, 998, 1000

MAIN CONTRACTOR :
Gammon

STRUCTURAL ENGINEER :
ARUP

FACADE CONSULTANT:
MEINHARDT

NOTE :
 1. ALL DIMENSIONS ARE IN mm.
 2. ALL ELEVATIONS ARE VIEWED FROM OUTSIDE.
 3. ALL DIMENSIONS TO BE VERIFIED ON SITE BEFORE FABRICATION.

LEGEND :
 x1 — DETAIL MARK NO.
 x001 — REFER SHEET NO.
 1. F.F.L. — FINISHED FLOOR LEVEL
 2. S.F.L. — STRUCTURAL FLOOR LEVEL
 3. (A) — REVERSED DETAIL
 — FIXING LOCATION
 — FIXING LUG LOCATION

GLASS LEGEND
 GL01 — 8mm+12mm AIR GAP+10mm THK. I.G.U.
 GL01a — 8mm+9mm AIR GAP+12mm THK. I.G.U.
 GL03 — 6mm+12mm AIR GAP+6mm THK. I.G.U.
 GL04 — 10mm THK. TEMPERED GLASS (PROTECTIVE BARRIER)
 GL05 — 6mm+12mm AIR GAP+8mm THK. I.G.U.

NO.	DATE	REVISION	BY
A	09/12/2020	REVISION SUBJECT TO ARCH.COMMENT	lvart

JOB NO. : J-852
 PROJECT : PROPOSED RESIDENTIAL DEVELOPMENT AT 139 - 147 ARGYLE STREET, NKIL 6005, 6035 R.P., 6036 R.P., 6037 R.P. & 6038 R.P.

TITLE : DETAIL FOR Plenum Box

DATE : 05-Dec-19 SCALE : 1:2
 DRAWN BY : MN CHECKED BY : DW

美特鋁質有限公司
MIDI ALUMINIUM FABRICATOR LTD.
 Units 6-8, Sunray Industrial Centre, 1/F
 610 Cha Kwo Ling Road, Kowloon
 Tel:23489211-4 Fax:(852)27727666
 DWG NO. : J852-SD-PB-5001 REV. : A

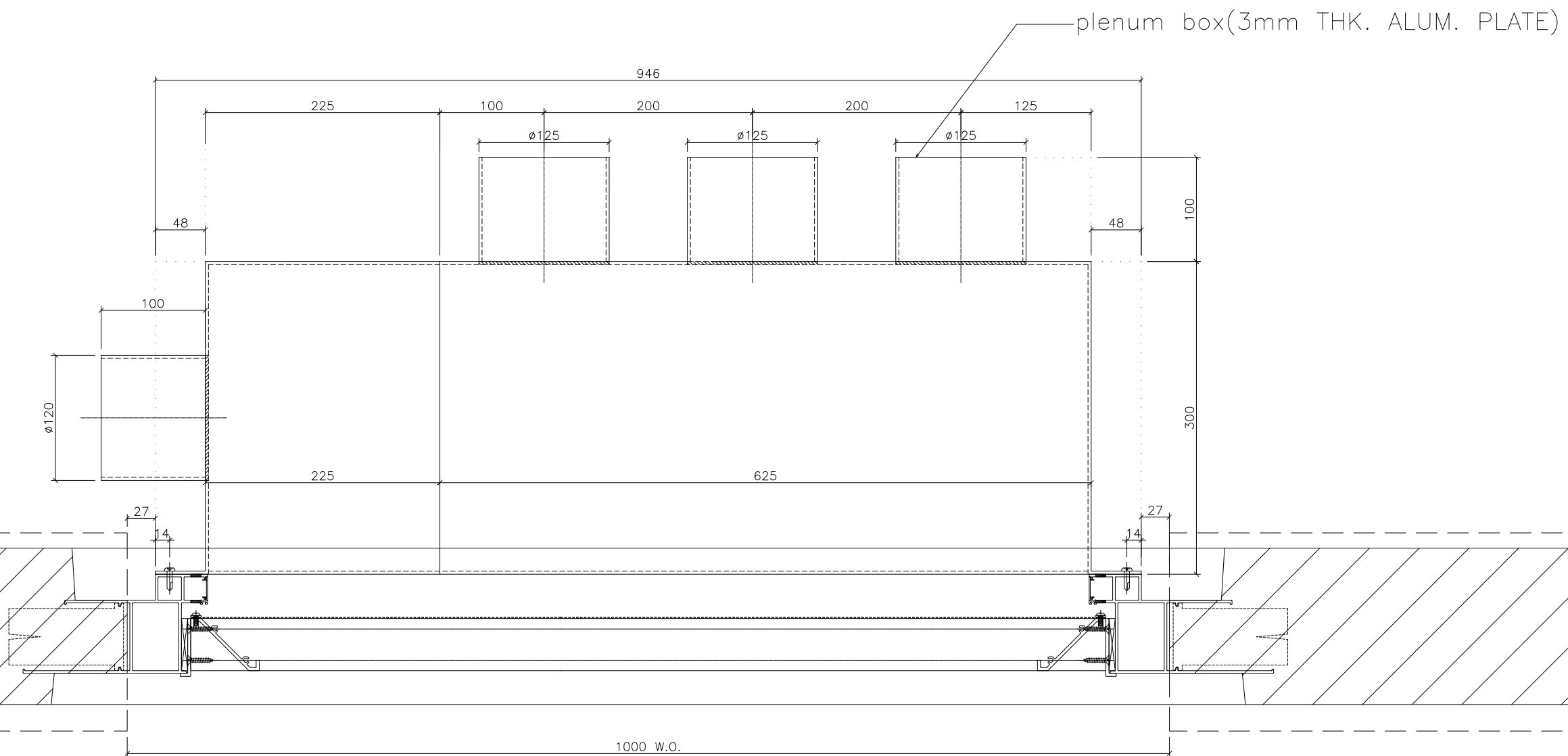

1 HORIZONTAL DETAIL SCALE 1:1 OUTSIDE

B.D. REF :

CLIENT :

ARCHITECT :
AGC DESIGN LTD
 181, 182, 183, 184, 185, 186, 187, 188, 189, 190, 191, 192, 193, 194, 195, 196, 197, 198, 199, 200, 201, 202, 203, 204, 205, 206, 207, 208, 209, 210, 211, 212, 213, 214, 215, 216, 217, 218, 219, 220, 221, 222, 223, 224, 225, 226, 227, 228, 229, 230, 231, 232, 233, 234, 235, 236, 237, 238, 239, 240, 241, 242, 243, 244, 245, 246, 247, 248, 249, 250, 251, 252, 253, 254, 255, 256, 257, 258, 259, 260, 261, 262, 263, 264, 265, 266, 267, 268, 269, 270, 271, 272, 273, 274, 275, 276, 277, 278, 279, 280, 281, 282, 283, 284, 285, 286, 287, 288, 289, 290, 291, 292, 293, 294, 295, 296, 297, 298, 299, 300, 301, 302, 303, 304, 305, 306, 307, 308, 309, 310, 311, 312, 313, 314, 315, 316, 317, 318, 319, 320, 321, 322, 323, 324, 325, 326, 327, 328, 329, 330, 331, 332, 333, 334, 335, 336, 337, 338, 339, 340, 341, 342, 343, 344, 345, 346, 347, 348, 349, 350, 351, 352, 353, 354, 355, 356, 357, 358, 359, 360, 361, 362, 363, 364, 365, 366, 367, 368, 369, 370, 371, 372, 373, 374, 375, 376, 377, 378, 379, 380, 381, 382, 383, 384, 385, 386, 387, 388, 389, 390, 391, 392, 393, 394, 395, 396, 397, 398, 399, 400, 401, 402, 403, 404, 405, 406, 407, 408, 409, 410, 411, 412, 413, 414, 415, 416, 417, 418, 419, 420, 421, 422, 423, 424, 425, 426, 427, 428, 429, 430, 431, 432, 433, 434, 435, 436, 437, 438, 439, 440, 441, 442, 443, 444, 445, 446, 447, 448, 449, 450, 451, 452, 453, 454, 455, 456, 457, 458, 459, 460, 461, 462, 463, 464, 465, 466, 467, 468, 469, 470, 471, 472, 473, 474, 475, 476, 477, 478, 479, 480, 481, 482, 483, 484, 485, 486, 487, 488, 489, 490, 491, 492, 493, 494, 495, 496, 497, 498, 499, 500, 501, 502, 503, 504, 505, 506, 507, 508, 509, 510, 511, 512, 513, 514, 515, 516, 517, 518, 519, 520, 521, 522, 523, 524, 525, 526, 527, 528, 529, 530, 531, 532, 533, 534, 535, 536, 537, 538, 539, 540, 541, 542, 543, 544, 545, 546, 547, 548, 549, 550, 551, 552, 553, 554, 555, 556, 557, 558, 559, 560, 561, 562, 563, 564, 565, 566, 567, 568, 569, 570, 571, 572, 573, 574, 575, 576, 577, 578, 579, 580, 581, 582, 583, 584, 585, 586, 587, 588, 589, 590, 591, 592, 593, 594, 595, 596, 597, 598, 599, 600, 601, 602, 603, 604, 605, 606, 607, 608, 609, 610, 611, 612, 613, 614, 615, 616, 617, 618, 619, 620, 621, 622, 623, 624, 625, 626, 627, 628, 629, 630, 631, 632, 633, 634, 635, 636, 637, 638, 639, 640, 641, 642, 643, 644, 645, 646, 647, 648, 649, 650, 651, 652, 653, 654, 655, 656, 657, 658, 659, 660, 661, 662, 663, 664, 665, 666, 667, 668, 669, 670, 671, 672, 673, 674, 675, 676, 677, 678, 679, 680, 681, 682, 683, 684, 685, 686, 687, 688, 689, 690, 691, 692, 693, 694, 695, 696, 697, 698, 699, 700, 701, 702, 703, 704, 705, 706, 707, 708, 709, 710, 711, 712, 713, 714, 715, 716, 717, 718, 719, 720, 721, 722, 723, 724, 725, 726, 727, 728, 729, 730, 731, 732, 733, 734, 735, 736, 737, 738, 739, 740, 741, 742, 743, 744, 745, 746, 747, 748, 749, 750, 751, 752, 753, 754, 755, 756, 757, 758, 759, 760, 761, 762, 763, 764, 765, 766, 767, 768, 769, 770, 771, 772, 773, 774, 775, 776, 777, 778, 779, 780, 781, 782, 783, 784, 785, 786, 787, 788, 789, 790, 791, 792, 793, 794, 795, 796, 797, 798, 799, 800, 801, 802, 803, 804, 805, 806, 807, 808, 809, 810, 811, 812, 813, 814, 815, 816, 817, 818, 819, 820, 821, 822, 823, 824, 825, 826, 827, 828, 829, 830, 831, 832, 833, 834, 835, 836, 837, 838, 839, 840, 841, 842, 843, 844, 845, 846, 847, 848, 849, 850, 851, 852, 853, 854, 855, 856, 857, 858, 859, 860, 861, 862, 863, 864, 865, 866, 867, 868, 869, 870, 871, 872, 873, 874, 875, 876, 877, 878, 879, 880, 881, 882, 883, 884, 885, 886, 887, 888, 889, 890, 891, 892, 893, 894, 895, 896, 897, 898, 899, 900, 901, 902, 903, 904, 905, 906, 907, 908, 909, 910, 911, 912, 913, 914, 915, 916, 917, 918, 919, 920, 921, 922, 923, 924, 925, 926, 927, 928, 929, 930, 931, 932, 933, 934, 935, 936, 937, 938, 939, 940, 941, 942, 943, 944, 945, 946, 947, 948, 949, 950, 951, 952, 953, 954, 955, 956, 957, 958, 959, 960, 961, 962, 963, 964, 965, 966, 967, 968, 969, 970, 971, 972, 973, 974, 975, 976, 977, 978, 979, 980, 981, 982, 983, 984, 985, 986, 987, 988, 989, 990, 991, 992, 993, 994, 995, 996, 997, 998, 999, 1000

NOTE :

1. ALL DIMENSIONS ARE IN mm.
2. ALL ELEVATIONS ARE VIEWED FROM OUTSIDE.
3. ALL DIMENSIONS TO BE VERIFIED ON SITE BEFORE FABRICATION.

LEGEND :

x1 — DETAIL MARK NO.
 x001 — REFER SHEET NO.

1. F.F.L. -- FINISHED FLOOR LEVEL
2. S.F.L. -- STRUCTURAL FLOOR LEVEL
3. (R) -- REVERSED DETAIL
- (F) -- FIXING LOCATION
- (L) -- FIXING LUG LOCATION

GLASS LEGEND

GL01 -- 8mm+12mm AIR GAP+10mm THK. I.G.U.
 GL01a -- 8mm+9mm AIR GAP+12mm THK. I.G.U.
 GL03 -- 6mm+12mm AIR GAP+6mm THK. I.G.U.
 GL04 -- 10mm THK. TEMPERED GLASS (PROTECTIVE BARRIER)
 GL05 -- 6mm+12mm AIR GAP+8mm THK. I.G.U.

NO.	DATE	REVISED	BY
JOB NO. : J-852			
PROJECT : PROPOSED RESIDENTIAL DEVELOPMENT AT 139 - 147 ARGYLE STREET, NKIL 6005, 6035 R.P., 6036 R.P., 6037 R.P. & 6038 R.P.			
TITLE : DETAIL FOR Plenum Box			
DATE : 05-Dec-19	SCALE : 1:2		
DRAWN BY : MN	CHECKED BY : DW		
<p>MIDI ALUMINIUM FABRICATOR LTD. Units 6-8, Sunray Industrial Centre, 1/F 610 Cha Kwo Ling Road, Kowloon Tel:23489211-4 Fax:(852)2727666</p>			
DWG NO. : J852-SD-PB-5001a	REV. : -		

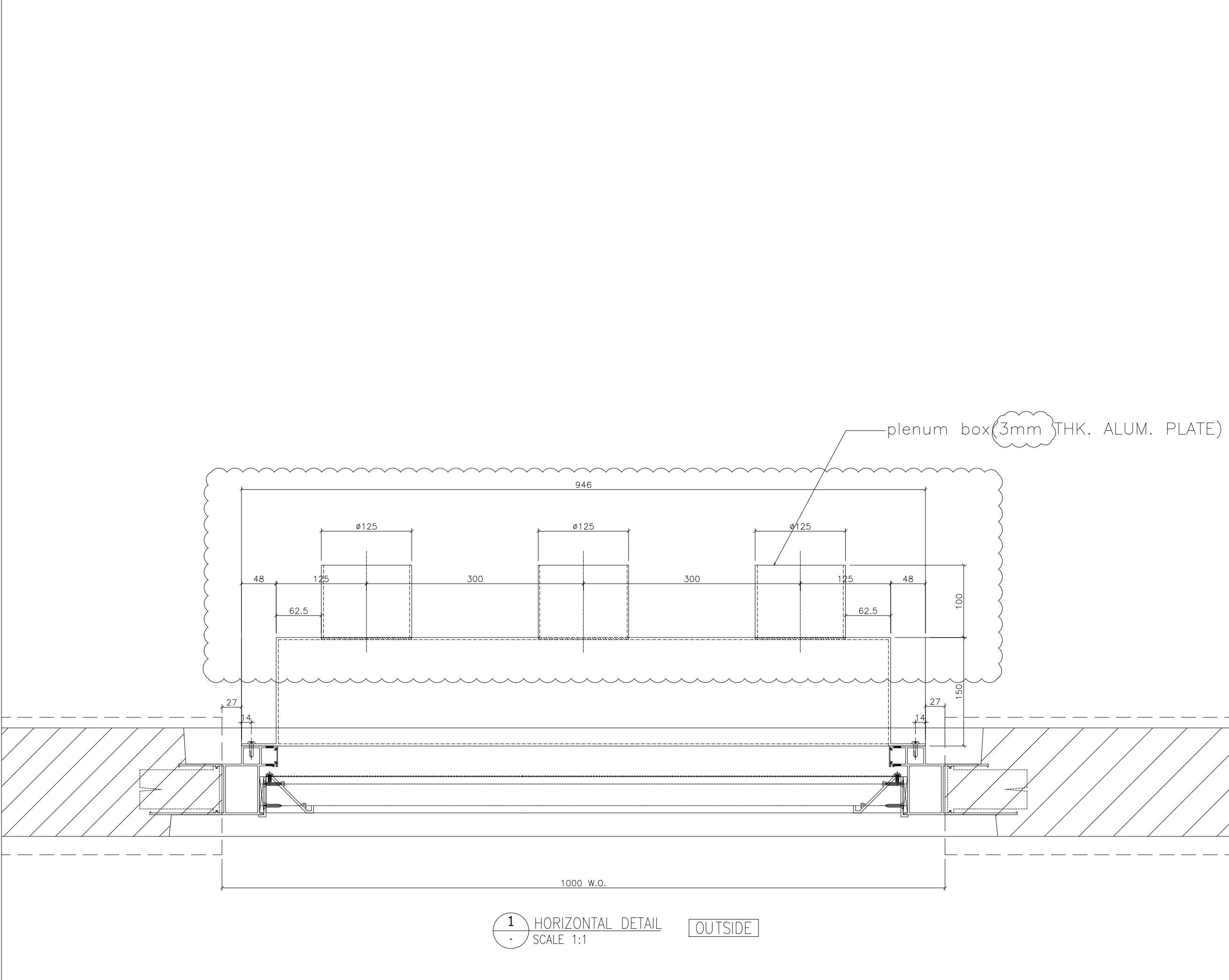

1 HORIZONTAL DETAIL OUTSIDE
SCALE 1:1

B.D. REF :

CLIENT :

ARCHITECT :
AGC DESIGN LTD
 181, 182, 183, 184, 185, 186, 187, 188, 189, 190, 191, 192, 193, 194, 195, 196, 197, 198, 199, 200, 201, 202, 203, 204, 205, 206, 207, 208, 209, 210, 211, 212, 213, 214, 215, 216, 217, 218, 219, 220, 221, 222, 223, 224, 225, 226, 227, 228, 229, 230, 231, 232, 233, 234, 235, 236, 237, 238, 239, 240, 241, 242, 243, 244, 245, 246, 247, 248, 249, 250, 251, 252, 253, 254, 255, 256, 257, 258, 259, 260, 261, 262, 263, 264, 265, 266, 267, 268, 269, 270, 271, 272, 273, 274, 275, 276, 277, 278, 279, 280, 281, 282, 283, 284, 285, 286, 287, 288, 289, 290, 291, 292, 293, 294, 295, 296, 297, 298, 299, 300, 301, 302, 303, 304, 305, 306, 307, 308, 309, 310, 311, 312, 313, 314, 315, 316, 317, 318, 319, 320, 321, 322, 323, 324, 325, 326, 327, 328, 329, 330, 331, 332, 333, 334, 335, 336, 337, 338, 339, 340, 341, 342, 343, 344, 345, 346, 347, 348, 349, 350, 351, 352, 353, 354, 355, 356, 357, 358, 359, 360, 361, 362, 363, 364, 365, 366, 367, 368, 369, 370, 371, 372, 373, 374, 375, 376, 377, 378, 379, 380, 381, 382, 383, 384, 385, 386, 387, 388, 389, 390, 391, 392, 393, 394, 395, 396, 397, 398, 399, 400, 401, 402, 403, 404, 405, 406, 407, 408, 409, 410, 411, 412, 413, 414, 415, 416, 417, 418, 419, 420, 421, 422, 423, 424, 425, 426, 427, 428, 429, 430, 431, 432, 433, 434, 435, 436, 437, 438, 439, 440, 441, 442, 443, 444, 445, 446, 447, 448, 449, 450, 451, 452, 453, 454, 455, 456, 457, 458, 459, 460, 461, 462, 463, 464, 465, 466, 467, 468, 469, 470, 471, 472, 473, 474, 475, 476, 477, 478, 479, 480, 481, 482, 483, 484, 485, 486, 487, 488, 489, 490, 491, 492, 493, 494, 495, 496, 497, 498, 499, 500, 501, 502, 503, 504, 505, 506, 507, 508, 509, 510, 511, 512, 513, 514, 515, 516, 517, 518, 519, 520, 521, 522, 523, 524, 525, 526, 527, 528, 529, 530, 531, 532, 533, 534, 535, 536, 537, 538, 539, 540, 541, 542, 543, 544, 545, 546, 547, 548, 549, 550, 551, 552, 553, 554, 555, 556, 557, 558, 559, 560, 561, 562, 563, 564, 565, 566, 567, 568, 569, 570, 571, 572, 573, 574, 575, 576, 577, 578, 579, 580, 581, 582, 583, 584, 585, 586, 587, 588, 589, 590, 591, 592, 593, 594, 595, 596, 597, 598, 599, 600, 601, 602, 603, 604, 605, 606, 607, 608, 609, 610, 611, 612, 613, 614, 615, 616, 617, 618, 619, 620, 621, 622, 623, 624, 625, 626, 627, 628, 629, 630, 631, 632, 633, 634, 635, 636, 637, 638, 639, 640, 641, 642, 643, 644, 645, 646, 647, 648, 649, 650, 651, 652, 653, 654, 655, 656, 657, 658, 659, 660, 661, 662, 663, 664, 665, 666, 667, 668, 669, 670, 671, 672, 673, 674, 675, 676, 677, 678, 679, 680, 681, 682, 683, 684, 685, 686, 687, 688, 689, 690, 691, 692, 693, 694, 695, 696, 697, 698, 699, 700, 701, 702, 703, 704, 705, 706, 707, 708, 709, 710, 711, 712, 713, 714, 715, 716, 717, 718, 719, 720, 721, 722, 723, 724, 725, 726, 727, 728, 729, 730, 731, 732, 733, 734, 735, 736, 737, 738, 739, 740, 741, 742, 743, 744, 745, 746, 747, 748, 749, 750, 751, 752, 753, 754, 755, 756, 757, 758, 759, 760, 761, 762, 763, 764, 765, 766, 767, 768, 769, 770, 771, 772, 773, 774, 775, 776, 777, 778, 779, 780, 781, 782, 783, 784, 785, 786, 787, 788, 789, 790, 791, 792, 793, 794, 795, 796, 797, 798, 799, 800, 801, 802, 803, 804, 805, 806, 807, 808, 809, 810, 811, 812, 813, 814, 815, 816, 817, 818, 819, 820, 821, 822, 823, 824, 825, 826, 827, 828, 829, 830, 831, 832, 833, 834, 835, 836, 837, 838, 839, 840, 841, 842, 843, 844, 845, 846, 847, 848, 849, 850, 851, 852, 853, 854, 855, 856, 857, 858, 859, 860, 861, 862, 863, 864, 865, 866, 867, 868, 869, 870, 871, 872, 873, 874, 875, 876, 877, 878, 879, 880, 881, 882, 883, 884, 885, 886, 887, 888, 889, 890, 891, 892, 893, 894, 895, 896, 897, 898, 899, 900, 901, 902, 903, 904, 905, 906, 907, 908, 909, 910, 911, 912, 913, 914, 915, 916, 917, 918, 919, 920, 921, 922, 923, 924, 925, 926, 927, 928, 929, 930, 931, 932, 933, 934, 935, 936, 937, 938, 939, 940, 941, 942, 943, 944, 945, 946, 947, 948, 949, 950, 951, 952, 953, 954, 955, 956, 957, 958, 959, 960, 961, 962, 963, 964, 965, 966, 967, 968, 969, 970, 971, 972, 973, 974, 975, 976, 977, 978, 979, 980, 981, 982, 983, 984, 985, 986, 987, 988, 989, 990, 991, 992, 993, 994, 995, 996, 997, 998, 999, 1000

MAIN CONTRACTOR :
Gammon

STRUCTURAL ENGINEER :
ARUP

FACADE CONSULTANT:
MEINHARDT

NOTE :
 1. ALL DIMENSIONS ARE IN mm.
 2. ALL ELEVATIONS ARE VIEWED FROM OUTSIDE.
 3. ALL DIMENSIONS TO BE VERIFIED ON SITE BEFORE FABRICATION.

LEGEND :
 x1 -- DETAIL MARK NO.
 x001 -- REFER SHEET NO.

1. F.F.L. -- FINISHED FLOOR LEVEL
 2. S.F.L. -- STRUCTURAL FLOOR LEVEL
 3. (R) -- REVERSED DETAIL
 -- FIXING LOCATION
 -- FIXING LUG LOCATION

GLASS LEGEND
 GL01 -- 8mm+12mm AIR GAP+10mm THK. I.G.U.
 GL01a -- 8mm+9mm AIR GAP+12mm THK. I.G.U.
 GL03 -- 6mm+12mm AIR GAP+6mm THK. I.G.U.
 GL04 -- 10mm THK. TEMPERED GLASS (PROTECTIVE BARRIER)
 GL05 -- 6mm+12mm AIR GAP+8mm THK. I.G.U.

A	07/11/2020	REVISION SUBJECT TO ARCH.COMMENT	Ivan
NO.	DATE	REVISED	BY
JOB NO. : J-852		PROJECT : PROPOSED RESIDENTIAL DEVELOPMENT AT 139 - 147 ARGYLE STREET, NKIL 6005, 6035 R.P., 6036 R.P., 6037 R.P. & 6038 R.P.	
TITLE : DETAIL FOR Plenum Box		DATE : 05-Dec-19 SCALE : 1:2	
DRAWN BY : MN		CHECKED BY : DW	
DWG NO. : J852-SD-PB-5002		REV. : A	

美特鋁質有限公司
MIDI ALUMINIUM FABRICATOR LTD.
 Units 6-8, Sunray Industrial Centre, 1/F
 610 Cha Kwo Ling Road, Kowloon
 Tel:23489211-4 Fax:(852)2727666

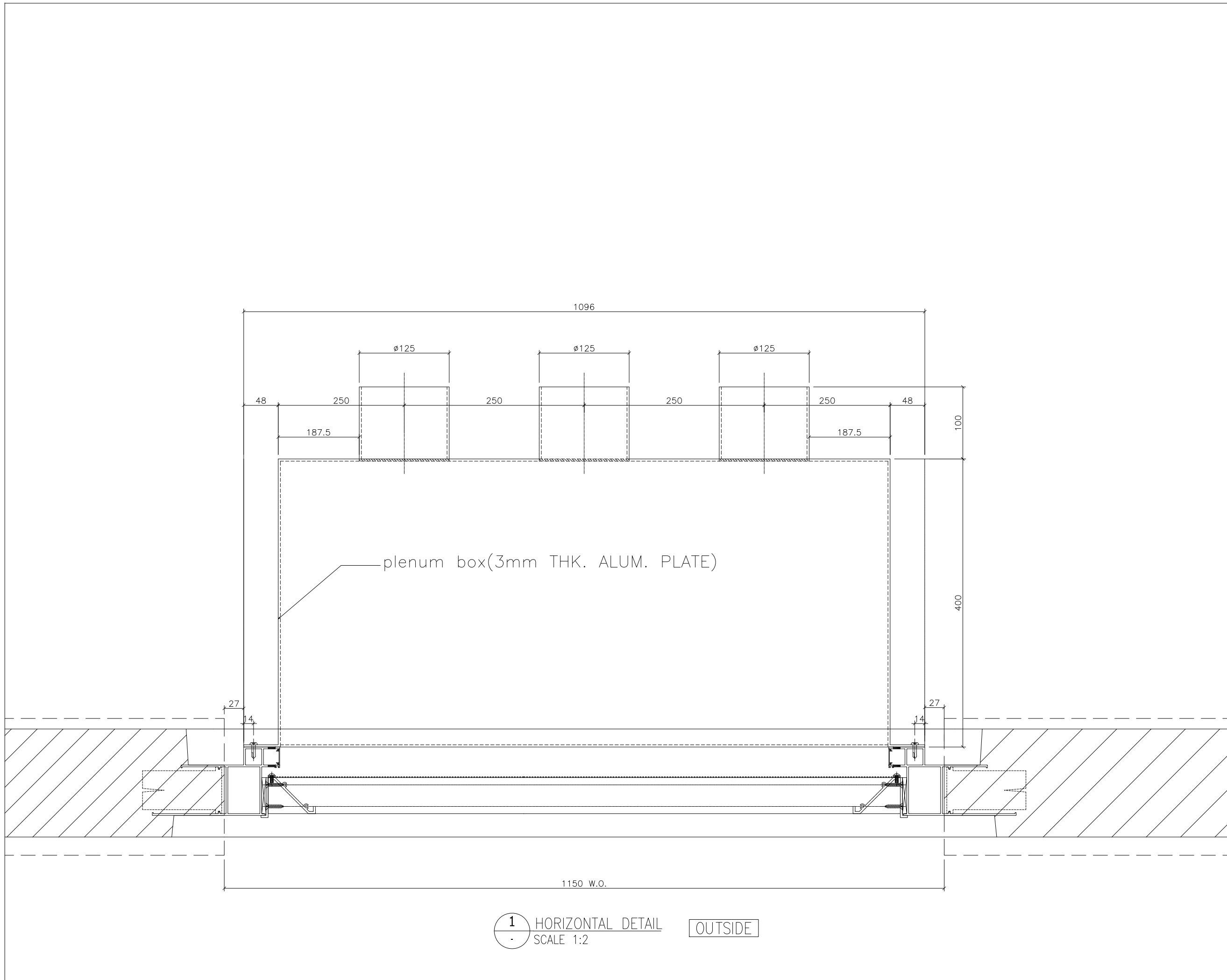

1 HORIZONTAL DETAIL OUTSIDE
SCALE 1:2

B.D. REF :

CLIENT :

ARCHITECT :
AGC
 DESIGN LTD
 187, 187, Upper Ring Road, 25th Floor, North Point, Hong Kong
 Tel: (852) 2721 1111 Fax: (852) 2721 1112 Email: agc@agc.com.hk

MAIN CONTRACTOR :
Gammon

STRUCTURAL ENGINEER :
ARUP

FAÇADE CONSULTANT:
MEINHARDT

NOTE :
 1. ALL DIMENSIONS ARE IN mm.
 2. ALL ELEVATIONS ARE VIEWED FROM OUTSIDE.
 3. ALL DIMENSIONS TO BE VERIFIED ON SITE BEFORE FABRICATION.

LEGEND :

(X1) — DETAIL MARK NO.
 (X001) — REFER SHEET NO.

1. F.F.L. -- FINISHED FLOOR LEVEL
 2. S.F.L. -- STRUCTURAL FLOOR LEVEL
 3. (R) -- REVERSED DETAIL
 -- FIXING LOCATION
 -- FIXING LUG LOCATION

GLASS LEGEND
 GL01 -- 8mm+12mm AIR GAP+10mm THK. I.G.U.
 GL01a -- 8mm+9mm AIR GAP+12mm THK. I.G.U.
 GL03 -- 6mm+12mm AIR GAP+6mm THK. I.G.U.
 GL04 -- 10mm THK. TEMPERED GLASS (PROTECTIVE BARRIER)
 GL05 -- 6mm+12mm AIR GAP+8mm THK. I.G.U.

NO.	DATE	REVISED	BY
-----	------	---------	----

JOB NO. : J-852
 PROJECT : PROPOSED RESIDENTIAL DEVELOPMENT AT 139 - 147 ARGYLE STREET, NKIL 6005, 6035 R.P., 6036 R.P., 6037 R.P. & 6038 R.P.

TITLE :
 DETAIL FOR Plenum Box

DATE : 05-Dec-19 SCALE : 1:2
 DRAWN BY : MN CHECKED BY : DW

MIDI 美特鋁質有限公司
 ALUMINIUM FABRICATOR LTD.
 Units 6-8, Sunray Industrial Centre, 1/F
 610 Cha Kwo Ling Road, Kowloon
 Tel:23489211-4 Fax:(852)2727666

DWG NO. : J852-SD-PB-5002a REV. : -

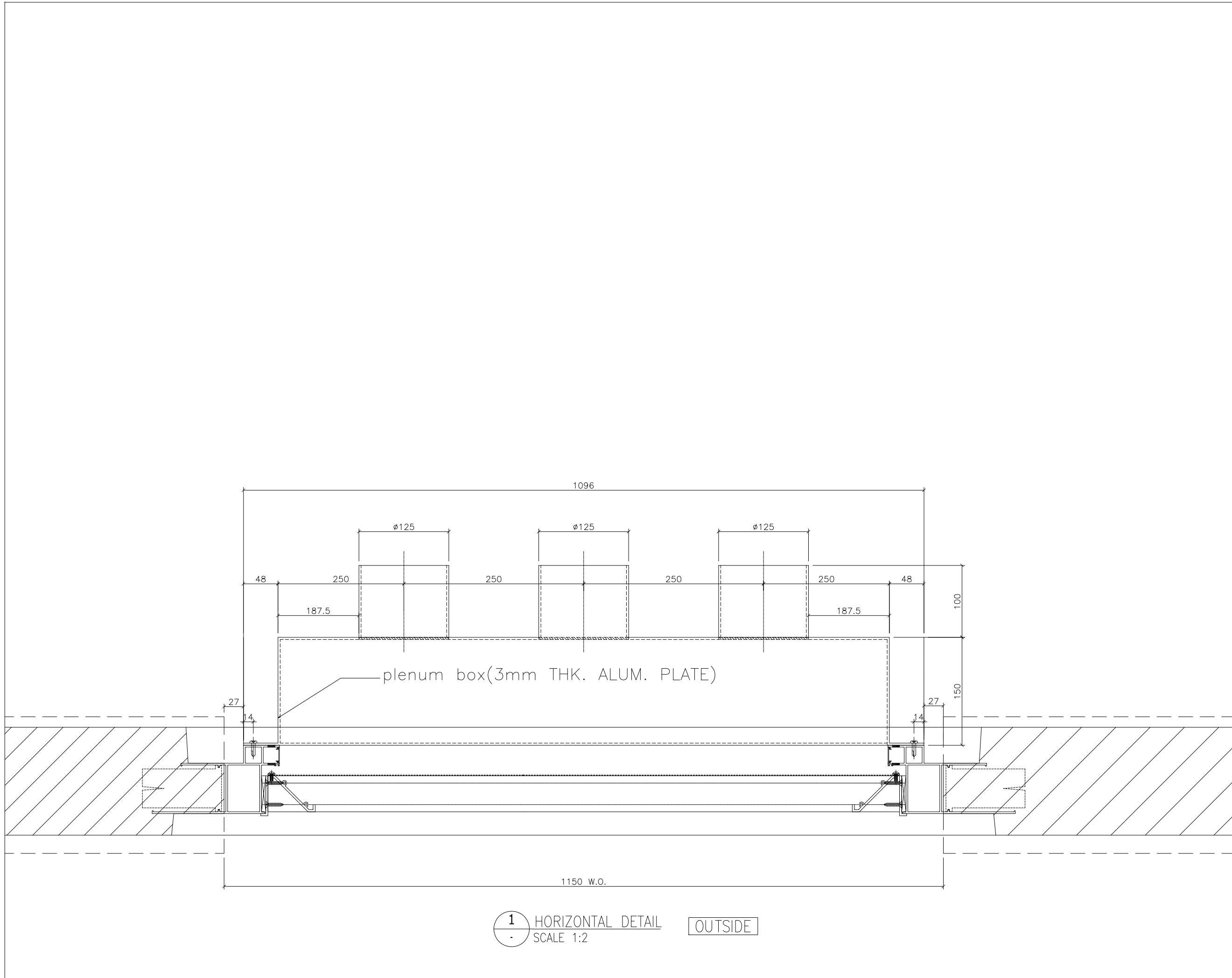

1 HORIZONTAL DETAIL OUTSIDE
SCALE 1:2

B.D. REF :

CLIENT :

ARCHITECT :
AGC DESIGN LTD
 香港建築師學會會員
 AGC Design Pty. Ltd. 221, King's Road, North Point, Hong Kong
 Tel: (852) 2771 1111 Fax: (852) 2771 1112 Email: agc@agcdesign.com.hk

MAIN CONTRACTOR :
Gammon

STRUCTURAL ENGINEER :
ARUP

FACADE CONSULTANT:
MEINHARDT

- NOTE :
1. ALL DIMENSIONS ARE IN mm.
 2. ALL ELEVATIONS ARE VIEWED FROM OUTSIDE.
 3. ALL DIMENSIONS TO BE VERIFIED ON SITE BEFORE FABRICATION.

- LEGEND :
- ⊙x1 --- DETAIL MARK NO.
 x001 --- REFER SHEET NO.
1. F.F.L. --- FINISHED FLOOR LEVEL
 2. S.F.L. --- STRUCTURAL FLOOR LEVEL
 3. (R) --- REVERSED DETAIL
 --- FIXING LOCATION
 --- FIXING LUG LOCATION
- GLASS LEGEND
 GL01 --- 8mm+12mm AIR GAP+10mm THK. I.G.U.
 GL01a --- 8mm+9mm AIR GAP+12mm THK. I.G.U.
 GL03 --- 6mm+12mm AIR GAP+6mm THK. I.G.U.
 GL04 --- 10mm THK. TEMPERED GLASS (PROTECTIVE BARRIER)
 GL05 --- 6mm+12mm AIR GAP+8mm THK. I.G.U.

NO.	DATE	REVISED	BY
JOB NO. : J-852			
PROJECT : PROPOSED RESIDENTIAL DEVELOPMENT AT 139 - 147 ARGYLE STREET, NKIL 6005, 6035 R.P., 6036 R.P., 6037 R.P. & 6038 R.P.			
TITLE : DETAIL FOR Plenum Box			
DATE : 05-Dec-19	SCALE : 1:2		
DRAWN BY : MN	CHECKED BY : DW		
美特鋁質有限公司 MIDI ALUMINIUM FABRICATOR LTD. Units 6-8, Sunray Industrial Centre, 1/F 610 Cha Kwo Ling Road, Kowloon Tel:23489211-4 Fax:(852)27727666			
DWG NO. : J852-SD-PB-5002b	REV. : -		

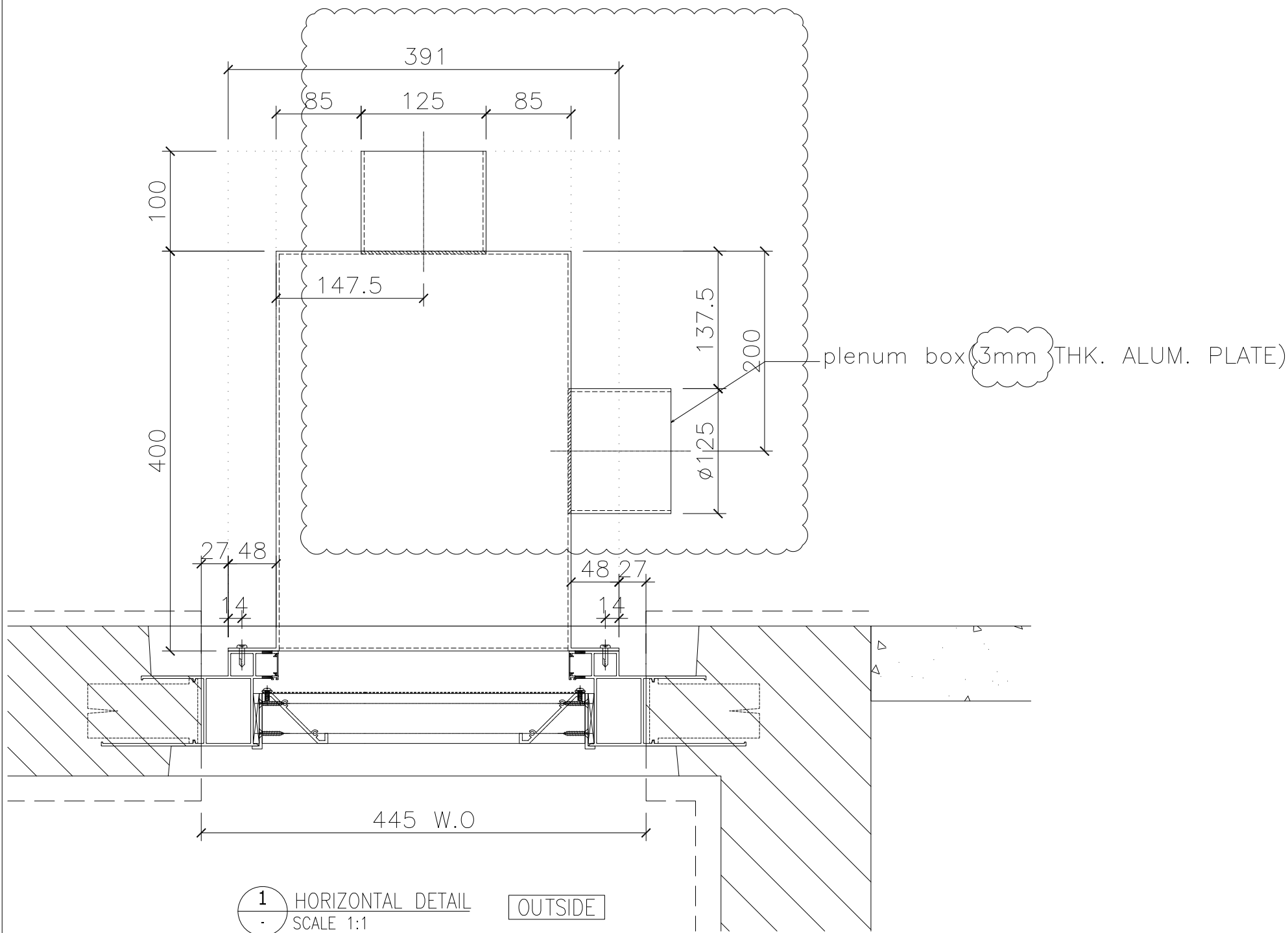

1 HORIZONTAL DETAIL
SCALE 1:1
OUTSIDE

plenum box (3mm THK. ALUM. PLATE)

B.D. REF :

CLIENT :

ARCHITECT :
AGC DESIGN LTD
AGC DESIGN LTD
101, 102, Ocean Park, 225, King's Road, Kowloon, Hong Kong
Tel: (852) 2711 1818 Fax: (852) 2711 1812 Email: agc@agc.com.hk

MAIN CONTRACTOR :
Gammon

STRUCTURAL ENGINEER :
ARUP

FACADE CONSULTANT:
MEINHARDT

NOTE :
1. ALL DIMENSIONS ARE IN mm.
2. ALL ELEVATIONS ARE VIEWED FROM OUTSIDE.
3. ALL DIMENSIONS TO BE VERIFIED ON SITE BEFORE FABRICATION.

LEGEND :
x1 — DETAIL MARK NO.
x001 — REFER SHEET NO.
1. F.F.L. -- FINISHED FLOOR LEVEL
2. S.F.L. -- STRUCTURAL FLOOR LEVEL
3. (R) -- REVERSED DETAIL
-- FIXING LOCATION
-- FIXING LUG LOCATION

GLASS LEGEND
GL01 -- 8mm+12mm AIR GAP+10mm THK. I.G.U.
GL01a -- 8mm+9mm AIR GAP+12mm THK. I.G.U.
GL03 -- 6mm+12mm AIR GAP+6mm THK. I.G.U.
GL04 -- 10mm THK. TEMPERED GLASS (PROTECTIVE BARRIER)
GL05 -- 6mm+12mm AIR GAP+8mm THK. I.G.U.

NO.	DATE	REVISION	BY
A	07/11/2020	REVISION SUBJECT TO ARCH.COMMENT	lvart

JOB NO. : J-852
PROJECT : PROPOSED RESIDENTIAL DEVELOPMENT AT 139 - 147 ARGYLE STREET, NKIL 6005, 6035 R.P., 6036 R.P., 6037 R.P. & 6038 R.P.

TITLE :
DETAIL FOR Plenum Box

DATE : 05-Dec-19 SCALE : 1:2

DRAWN BY : MN CHECKED BY : DW

美特鋁質有限公司
MIDI ALUMINIUM FABRICATOR LTD.
Units 6-8, Sunray Industrial Centre, 1/F
610 Cha Kwo Ling Road, Kowloon
Tel:23489211-4 Fax:(852)2727666

DWG NO. : J852-SD-PB-5003 REV. : A

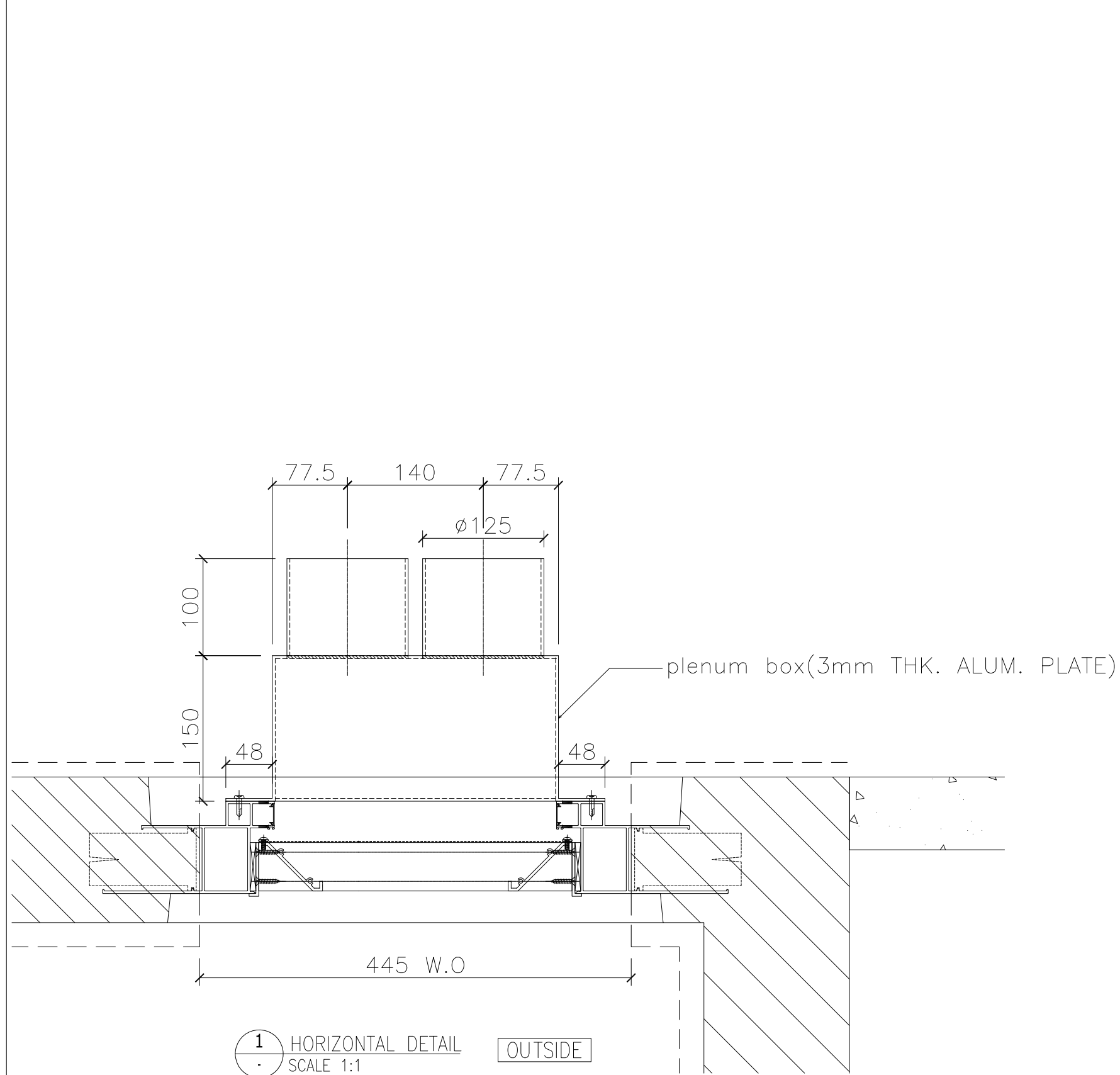

1 HORIZONTAL DETAIL
SCALE 1:1

OUTSIDE

B.D. REF :

CLIENT :

ARCHITECT :
AGC DESIGN LTD
AGC DESIGN LTD
181, 182, 183, 184, 185, 186, 187, 188, 189, 190, 191, 192, 193, 194, 195, 196, 197, 198, 199, 200, 201, 202, 203, 204, 205, 206, 207, 208, 209, 210, 211, 212, 213, 214, 215, 216, 217, 218, 219, 220, 221, 222, 223, 224, 225, 226, 227, 228, 229, 230, 231, 232, 233, 234, 235, 236, 237, 238, 239, 240, 241, 242, 243, 244, 245, 246, 247, 248, 249, 250, 251, 252, 253, 254, 255, 256, 257, 258, 259, 260, 261, 262, 263, 264, 265, 266, 267, 268, 269, 270, 271, 272, 273, 274, 275, 276, 277, 278, 279, 280, 281, 282, 283, 284, 285, 286, 287, 288, 289, 290, 291, 292, 293, 294, 295, 296, 297, 298, 299, 300, 301, 302, 303, 304, 305, 306, 307, 308, 309, 310, 311, 312, 313, 314, 315, 316, 317, 318, 319, 320, 321, 322, 323, 324, 325, 326, 327, 328, 329, 330, 331, 332, 333, 334, 335, 336, 337, 338, 339, 340, 341, 342, 343, 344, 345, 346, 347, 348, 349, 350, 351, 352, 353, 354, 355, 356, 357, 358, 359, 360, 361, 362, 363, 364, 365, 366, 367, 368, 369, 370, 371, 372, 373, 374, 375, 376, 377, 378, 379, 380, 381, 382, 383, 384, 385, 386, 387, 388, 389, 390, 391, 392, 393, 394, 395, 396, 397, 398, 399, 400, 401, 402, 403, 404, 405, 406, 407, 408, 409, 410, 411, 412, 413, 414, 415, 416, 417, 418, 419, 420, 421, 422, 423, 424, 425, 426, 427, 428, 429, 430, 431, 432, 433, 434, 435, 436, 437, 438, 439, 440, 441, 442, 443, 444, 445, 446, 447, 448, 449, 450, 451, 452, 453, 454, 455, 456, 457, 458, 459, 460, 461, 462, 463, 464, 465, 466, 467, 468, 469, 470, 471, 472, 473, 474, 475, 476, 477, 478, 479, 480, 481, 482, 483, 484, 485, 486, 487, 488, 489, 490, 491, 492, 493, 494, 495, 496, 497, 498, 499, 500, 501, 502, 503, 504, 505, 506, 507, 508, 509, 510, 511, 512, 513, 514, 515, 516, 517, 518, 519, 520, 521, 522, 523, 524, 525, 526, 527, 528, 529, 530, 531, 532, 533, 534, 535, 536, 537, 538, 539, 540, 541, 542, 543, 544, 545, 546, 547, 548, 549, 550, 551, 552, 553, 554, 555, 556, 557, 558, 559, 560, 561, 562, 563, 564, 565, 566, 567, 568, 569, 570, 571, 572, 573, 574, 575, 576, 577, 578, 579, 580, 581, 582, 583, 584, 585, 586, 587, 588, 589, 590, 591, 592, 593, 594, 595, 596, 597, 598, 599, 600, 601, 602, 603, 604, 605, 606, 607, 608, 609, 610, 611, 612, 613, 614, 615, 616, 617, 618, 619, 620, 621, 622, 623, 624, 625, 626, 627, 628, 629, 630, 631, 632, 633, 634, 635, 636, 637, 638, 639, 640, 641, 642, 643, 644, 645, 646, 647, 648, 649, 650, 651, 652, 653, 654, 655, 656, 657, 658, 659, 660, 661, 662, 663, 664, 665, 666, 667, 668, 669, 670, 671, 672, 673, 674, 675, 676, 677, 678, 679, 680, 681, 682, 683, 684, 685, 686, 687, 688, 689, 690, 691, 692, 693, 694, 695, 696, 697, 698, 699, 700, 701, 702, 703, 704, 705, 706, 707, 708, 709, 710, 711, 712, 713, 714, 715, 716, 717, 718, 719, 720, 721, 722, 723, 724, 725, 726, 727, 728, 729, 730, 731, 732, 733, 734, 735, 736, 737, 738, 739, 740, 741, 742, 743, 744, 745, 746, 747, 748, 749, 750, 751, 752, 753, 754, 755, 756, 757, 758, 759, 760, 761, 762, 763, 764, 765, 766, 767, 768, 769, 770, 771, 772, 773, 774, 775, 776, 777, 778, 779, 780, 781, 782, 783, 784, 785, 786, 787, 788, 789, 790, 791, 792, 793, 794, 795, 796, 797, 798, 799, 800, 801, 802, 803, 804, 805, 806, 807, 808, 809, 810, 811, 812, 813, 814, 815, 816, 817, 818, 819, 820, 821, 822, 823, 824, 825, 826, 827, 828, 829, 830, 831, 832, 833, 834, 835, 836, 837, 838, 839, 840, 841, 842, 843, 844, 845, 846, 847, 848, 849, 850, 851, 852, 853, 854, 855, 856, 857, 858, 859, 860, 861, 862, 863, 864, 865, 866, 867, 868, 869, 870, 871, 872, 873, 874, 875, 876, 877, 878, 879, 880, 881, 882, 883, 884, 885, 886, 887, 888, 889, 890, 891, 892, 893, 894, 895, 896, 897, 898, 899, 900, 901, 902, 903, 904, 905, 906, 907, 908, 909, 910, 911, 912, 913, 914, 915, 916, 917, 918, 919, 920, 921, 922, 923, 924, 925, 926, 927, 928, 929, 930, 931, 932, 933, 934, 935, 936, 937, 938, 939, 940, 941, 942, 943, 944, 945, 946, 947, 948, 949, 950, 951, 952, 953, 954, 955, 956, 957, 958, 959, 960, 961, 962, 963, 964, 965, 966, 967, 968, 969, 970, 971, 972, 973, 974, 975, 976, 977, 978, 979, 980, 981, 982, 983, 984, 985, 986, 987, 988, 989, 990, 991, 992, 993, 994, 995, 996, 997, 998, 999, 1000

MAIN CONTRACTOR :
Gammon

STRUCTURAL ENGINEER :
ARUP

FACADE CONSULTANT:
MEINHARDT

NOTE :
1. ALL DIMENSIONS ARE IN mm.
2. ALL ELEVATIONS ARE VIEWED FROM OUTSIDE.
3. ALL DIMENSIONS TO BE VERIFIED ON SITE BEFORE FABRICATION.

LEGEND :
x1 -- DETAIL MARK NO.
x001 -- REFER SHEET NO.
1. F.F.L. -- FINISHED FLOOR LEVEL
2. S.F.L. -- STRUCTURAL FLOOR LEVEL
3. (R) -- REVERSED DETAIL
-- FIXING LOCATION
-- FIXING LUG LOCATION

GLASS LEGEND
GL01 -- 8mm+12mm AIR GAP+10mm THK. I.G.U.
GL01a -- 8mm+9mm AIR GAP+12mm THK. I.G.U.
GL03 -- 6mm+12mm AIR GAP+6mm THK. I.G.U.
GL04 -- 10mm THK. TEMPERED GLASS (PROTECTIVE BARRIER)
GL05 -- 6mm+12mm AIR GAP+8mm THK. I.G.U.

NO.	DATE	REVISED	BY

JOB NO. : J-852

PROJECT :
PROPOSED RESIDENTIAL DEVELOPMENT
AT 139 - 147 ARGYLE STREET,
NKIL 6005, 6035 R.P., 6036 R.P.,
6037 R.P. & 6038 R.P.

TITLE :
DETAIL FOR
Plenum Box

DATE : 05-Dec-19 SCALE : 1:2

DRAWN BY : MN CHECKED BY : DW

美特鋁質有限公司
MIDI ALUMINIUM FABRICATOR LTD.
Units 6-8, Sunray Industrial Centre, 1/F
610 Cha Kwo Ling Road, Kowloon
Tel:23489211-4 Fax:(852)2727666

DWG NO. : J852-SD-PB-5003a REV. : -

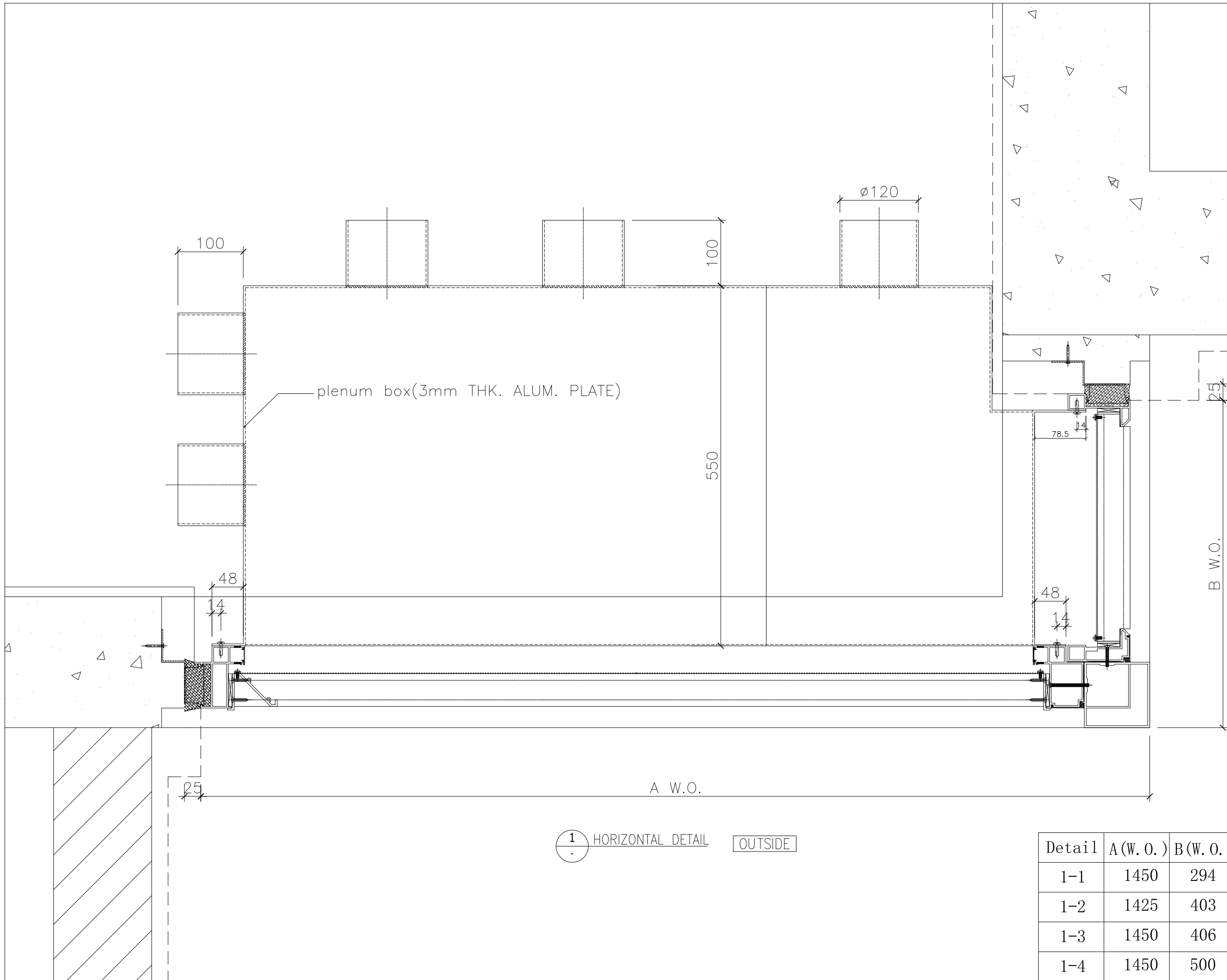

1 HORIZONTAL DETAIL OUTSIDE

Detail	A (W. O.)	B (W. O.)
1-1	1450	294
1-2	1425	403
1-3	1450	406
1-4	1450	500

B.D. REF :

CLIENT :

ARCHITECT :
AGC DESIGN LTD
 110, 112, 114, 116, 118, 120, 122, 124, 126, 128, 130, 132, 134, 136, 138, 140, 142, 144, 146, 148, 150, 152, 154, 156, 158, 160, 162, 164, 166, 168, 170, 172, 174, 176, 178, 180, 182, 184, 186, 188, 190, 192, 194, 196, 198, 200, 202, 204, 206, 208, 210, 212, 214, 216, 218, 220, 222, 224, 226, 228, 230, 232, 234, 236, 238, 240, 242, 244, 246, 248, 250, 252, 254, 256, 258, 260, 262, 264, 266, 268, 270, 272, 274, 276, 278, 280, 282, 284, 286, 288, 290, 292, 294, 296, 298, 300, 302, 304, 306, 308, 310, 312, 314, 316, 318, 320, 322, 324, 326, 328, 330, 332, 334, 336, 338, 340, 342, 344, 346, 348, 350, 352, 354, 356, 358, 360, 362, 364, 366, 368, 370, 372, 374, 376, 378, 380, 382, 384, 386, 388, 390, 392, 394, 396, 398, 400, 402, 404, 406, 408, 410, 412, 414, 416, 418, 420, 422, 424, 426, 428, 430, 432, 434, 436, 438, 440, 442, 444, 446, 448, 450, 452, 454, 456, 458, 460, 462, 464, 466, 468, 470, 472, 474, 476, 478, 480, 482, 484, 486, 488, 490, 492, 494, 496, 498, 500, 502, 504, 506, 508, 510, 512, 514, 516, 518, 520, 522, 524, 526, 528, 530, 532, 534, 536, 538, 540, 542, 544, 546, 548, 550, 552, 554, 556, 558, 560, 562, 564, 566, 568, 570, 572, 574, 576, 578, 580, 582, 584, 586, 588, 590, 592, 594, 596, 598, 600, 602, 604, 606, 608, 610, 612, 614, 616, 618, 620, 622, 624, 626, 628, 630, 632, 634, 636, 638, 640, 642, 644, 646, 648, 650, 652, 654, 656, 658, 660, 662, 664, 666, 668, 670, 672, 674, 676, 678, 680, 682, 684, 686, 688, 690, 692, 694, 696, 698, 700, 702, 704, 706, 708, 710, 712, 714, 716, 718, 720, 722, 724, 726, 728, 730, 732, 734, 736, 738, 740, 742, 744, 746, 748, 750, 752, 754, 756, 758, 760, 762, 764, 766, 768, 770, 772, 774, 776, 778, 780, 782, 784, 786, 788, 790, 792, 794, 796, 798, 800, 802, 804, 806, 808, 810, 812, 814, 816, 818, 820, 822, 824, 826, 828, 830, 832, 834, 836, 838, 840, 842, 844, 846, 848, 850, 852, 854, 856, 858, 860, 862, 864, 866, 868, 870, 872, 874, 876, 878, 880, 882, 884, 886, 888, 890, 892, 894, 896, 898, 900, 902, 904, 906, 908, 910, 912, 914, 916, 918, 920, 922, 924, 926, 928, 930, 932, 934, 936, 938, 940, 942, 944, 946, 948, 950, 952, 954, 956, 958, 960, 962, 964, 966, 968, 970, 972, 974, 976, 978, 980, 982, 984, 986, 988, 990, 992, 994, 996, 998, 1000

MAIN CONTRACTOR :
Gammon

STRUCTURAL ENGINEER :
ARUP

FACADE CONSULTANT:
MEINHARDT

- NOTE :
1. ALL DIMENSIONS ARE IN mm.
 2. ALL ELEVATIONS ARE VIEWED FROM OUTSIDE.
 3. ALL DIMENSIONS TO BE VERIFIED ON SITE BEFORE FABRICATION.

- LEGEND :
- x1 — DETAIL MARK NO.
 - x001 — REFER SHEET NO.
 - 1. F.F.L. — FINISHED FLOOR LEVEL
 - 2. S.F.L. — STRUCTURAL FLOOR LEVEL
 - 3. (A) — REVERSED DETAIL
 - FIXING LOCATION
 - FIXING LUG LOCATION

- GLASS LEGEND
- GL01 — 8mm+12mm AIR GAP+10mm THK. I.G.U.
 - GL01a — 8mm+9mm AIR GAP+12mm THK. I.G.U.
 - GL03 — 6mm+12mm AIR GAP+6mm THK. I.G.U.
 - GL04 — 10mm THK. TEMPERED GLASS (PROTECTIVE BARRIER)
 - GL05 — 6mm+12mm AIR GAP+8mm THK. I.G.U.

NO.	DATE	REVISION	BY
A	09/12/2020	REVISION SUBJECT TO ARCH.COMMENT	lvn

JOB NO. : J-852

PROJECT :
 PROPOSED RESIDENTIAL DEVELOPMENT
 AT 139 - 147 ARGYLE STREET,
 NKIL 6005, 6035 R.P., 6036 R.P.,
 6037 R.P. & 6038 R.P.

TITLE :
 DETAIL FOR
 Plenum Box

DATE : 05-Dec-19 SCALE : 1:2

DRAWN BY : MN CHECKED BY : DW

美特鋁質有限公司
MIDI ALUMINIUM FABRICATOR LTD.
 Units 6-8, Sunray Industrial Centre, 1/F
 610 Cha Kwo Ling Road, Kowloon
 Tel:23489211-4 Fax:(852)2727666

DWG NO. : J852-SD-PB-5004 REV. : A

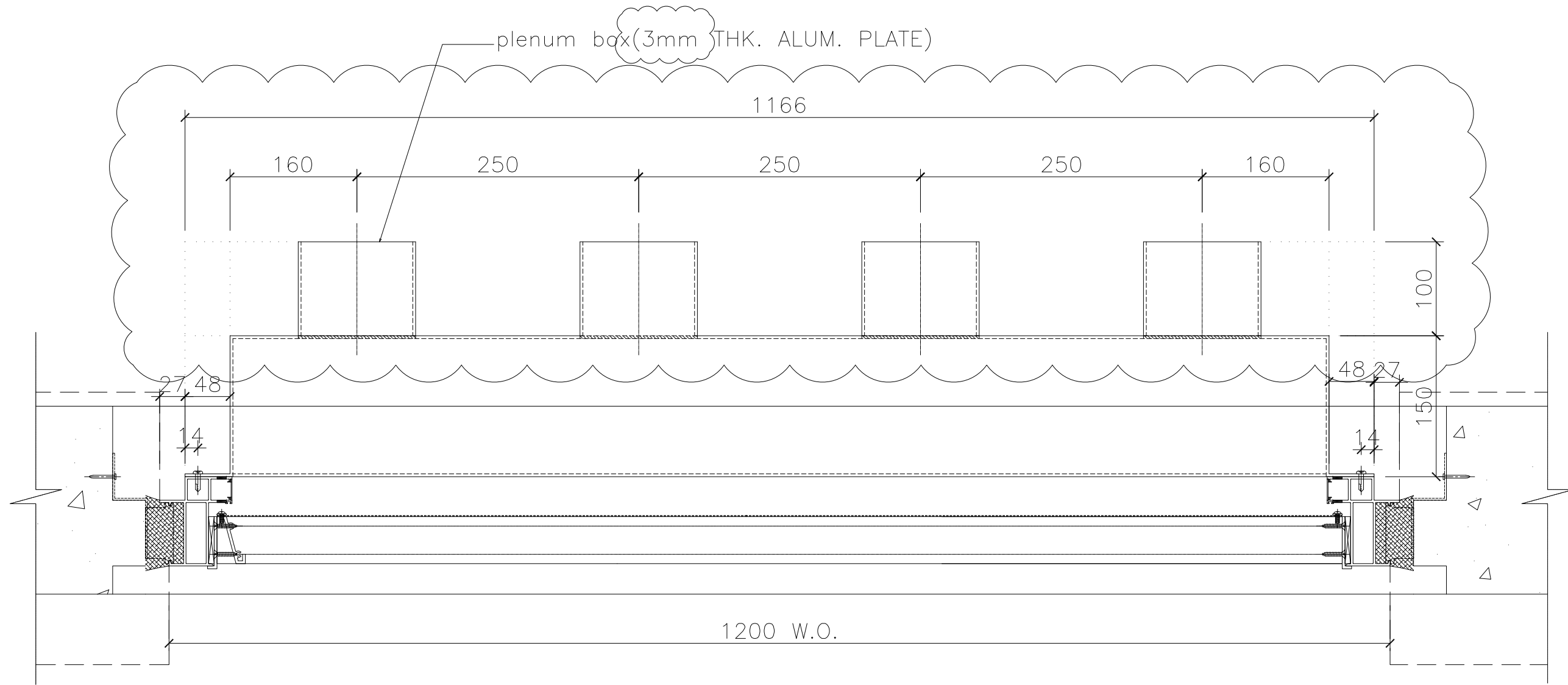

1 HORIZONTAL DETAIL OUTSIDE

B.D. REF :

CLIENT :

ARCHITECT :
AGC DESIGN LTD
 101, 102, 103, 104, 105, 106, 107, 108, 109, 110, 111, 112, 113, 114, 115, 116, 117, 118, 119, 120, 121, 122, 123, 124, 125, 126, 127, 128, 129, 130, 131, 132, 133, 134, 135, 136, 137, 138, 139, 140, 141, 142, 143, 144, 145, 146, 147, 148, 149, 150, 151, 152, 153, 154, 155, 156, 157, 158, 159, 160, 161, 162, 163, 164, 165, 166, 167, 168, 169, 170, 171, 172, 173, 174, 175, 176, 177, 178, 179, 180, 181, 182, 183, 184, 185, 186, 187, 188, 189, 190, 191, 192, 193, 194, 195, 196, 197, 198, 199, 200

MAIN CONTRACTOR :
Gammon

STRUCTURAL ENGINEER :
ARUP

FAÇADE CONSULTANT:
MEINHARDT

NOTE :
 1. ALL DIMENSIONS ARE IN mm.
 2. ALL ELEVATIONS ARE VIEWED FROM OUTSIDE.
 3. ALL DIMENSIONS TO BE VERIFIED ON SITE BEFORE FABRICATION.

LEGEND :
 x1 --- DETAIL MARK NO.
 x001 --- REFER SHEET NO.
 1. F.F.L. --- FINISHED FLOOR LEVEL
 2. S.F.L. --- STRUCTURAL FLOOR LEVEL
 3. (R) --- REVERSED DETAIL
 --- FIXING LOCATION
 --- FIXING LUG LOCATION

GLASS LEGEND
 GL01 --- 8mm+12mm AIR GAP+10mm THK. I.G.U.
 GL01a --- 8mm+9mm AIR GAP+12mm THK. I.G.U.
 GL03 --- 6mm+12mm AIR GAP+6mm THK. I.G.U.
 GL04 --- 10mm THK. TEMPERED GLASS (PROTECTIVE BARRIER)
 GL05 --- 6mm+12mm AIR GAP+8mm THK. I.G.U.

NO.	DATE	REVISION	BY
A	07/11/2020	REVISION SUBJECT TO ARCH.COMMENT	lvn

JOB NO. : J-852
 PROJECT :
 PROPOSED RESIDENTIAL DEVELOPMENT
 AT 139 - 147 ARGYLE STREET,
 NKIL 6005, 6035 R.P., 6036 R.P.,
 6037 R.P. & 6038 R.P.

TITLE :
 DETAIL FOR
 Plenum Box

DATE : 05-Dec-19 SCALE : 1:2
 DRAWN BY : MN CHECKED BY : DW

美特鋁質有限公司
MIDI ALUMINIUM FABRICATOR LTD.
 Units 6-8, Sunray Industrial Centre, 1/F
 610 Cha Kwo Ling Road, Kowloon
 Tel:23489211-4 Fax:(852)2727666

DWG NO. : J852-SD-PB-5005 REV. : A

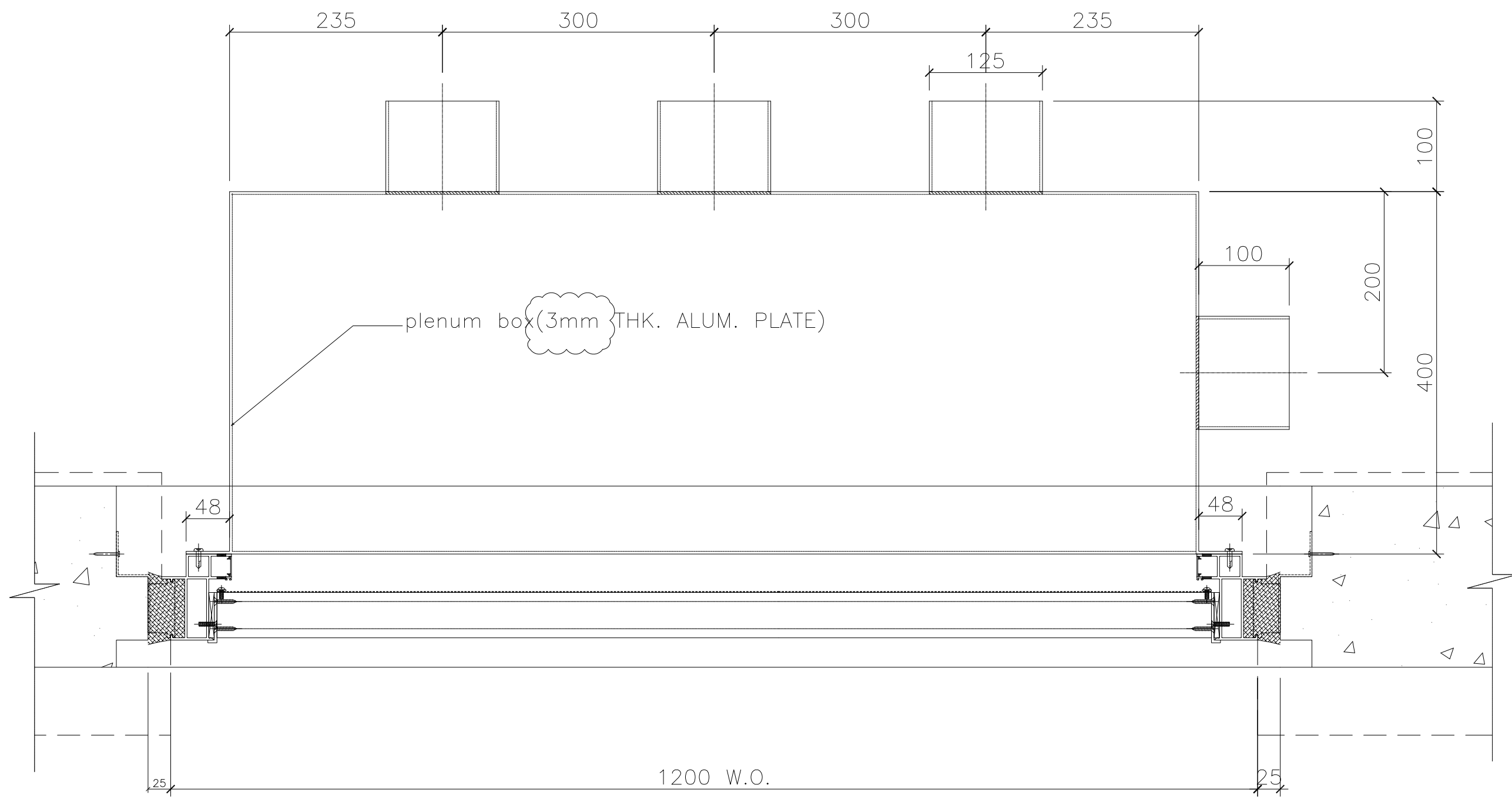

1 HORIZONTAL DETAIL OUTSIDE
SCALE 1:1

B.D. REF :

CLIENT :

ARCHITECT :
AGC DESIGN LTD

MAIN CONTRACTOR :
Gammon

STRUCTURAL ENGINEER :
ARUP

FACADE CONSULTANT:
MEINHARDT

NOTE :

- ALL DIMENSIONS ARE IN mm.
- ALL ELEVATIONS ARE VIEWED FROM OUTSIDE.
- ALL DIMENSIONS TO BE VERIFIED ON SITE BEFORE FABRICATION.

LEGEND :

x1 -- DETAIL MARK NO.
x001 -- REFER SHEET NO.

- F.F.L. -- FINISHED FLOOR LEVEL
- S.F.L. -- STRUCTURAL FLOOR LEVEL
- (R) -- REVERSED DETAIL
- FIXING LOCATION
- FIXING LUG LOCATION

GLASS LEGEND

GL01 -- 8mm+12mm AIR GAP+10mm THK. I.G.U.
GL01a -- 8mm+9mm AIR GAP+12mm THK. I.G.U.
GL03 -- 6mm+12mm AIR GAP+6mm THK. I.G.U.
GL04 -- 10mm THK. TEMPERED GLASS (PROTECTIVE BARRIER)
GL05 -- 6mm+12mm AIR GAP+8mm THK. I.G.U.

NO.	DATE	REVISED	BY
JOB NO. : J-852			
PROJECT : PROPOSED RESIDENTIAL DEVELOPMENT AT 139 - 147 ARGYLE STREET, NKIL 6005, 6035 R.P., 6036 R.P., 6037 R.P. & 6038 R.P.			
TITLE : DETAIL FOR Plenum Box			
DATE : 05-Dec-19		SCALE : 1:2	
DRAWN BY : MN		CHECKED BY : DW	
<p>美特鋁質有限公司 MIDI ALUMINIUM FABRICATOR LTD. Units 6-8, Sunray Industrial Centre, 1/F 610 Cha Kwo Ling Road, Kowloon Tel:23489211-4 Fax:(852)2727666</p>			
DWG NO. : J852-SD-PB-5006			REV. : -

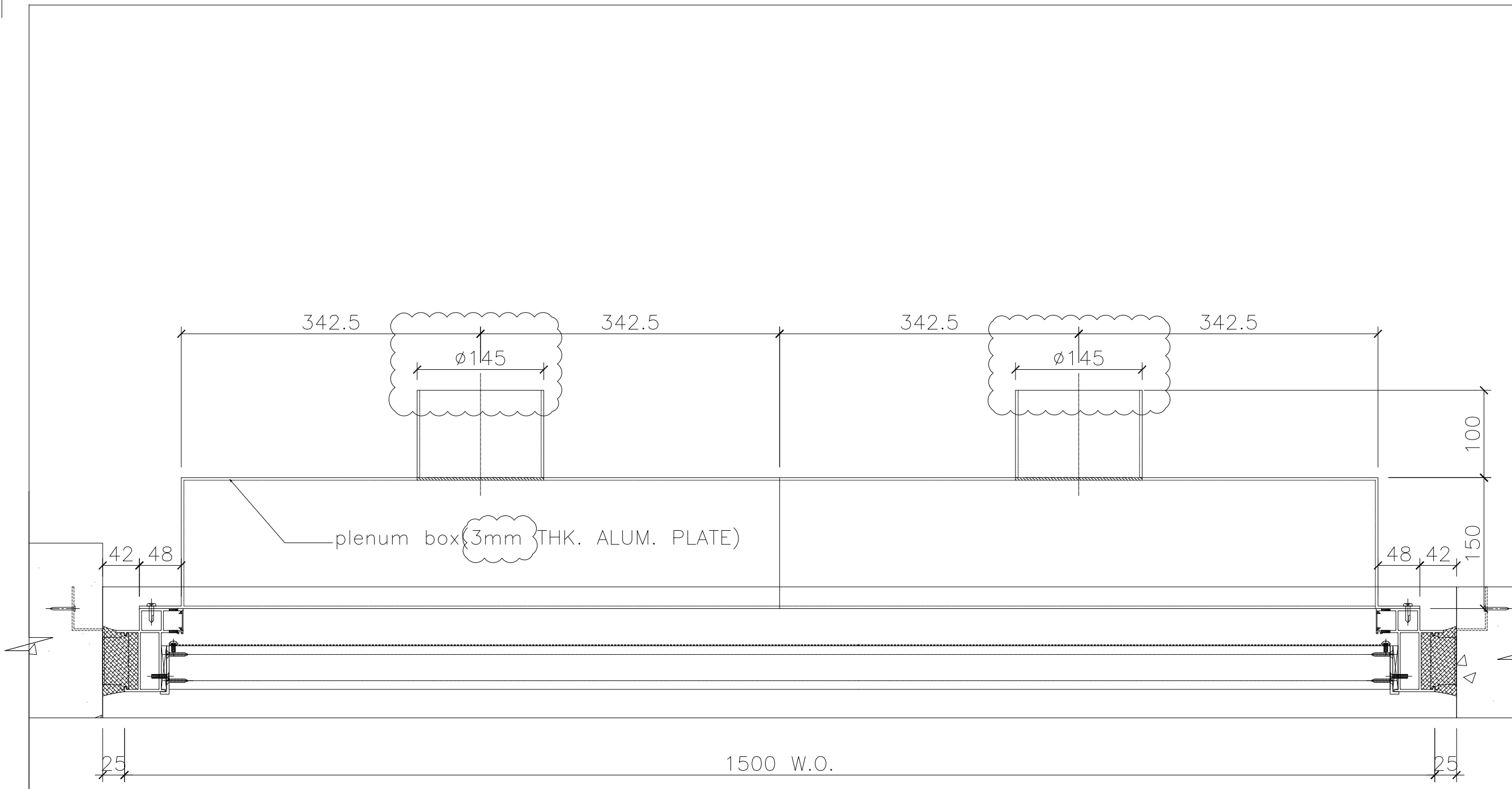

1 HORIZONTAL DETAIL
SCALE 1:1
OUTSIDE

B.D. REF :

CLIENT :

ARCHITECT :
AGC DESIGN LTD
101, 102, 103, 104, 105, 106, 107, 108, 109, 110, 111, 112, 113, 114, 115, 116, 117, 118, 119, 120, 121, 122, 123, 124, 125, 126, 127, 128, 129, 130, 131, 132, 133, 134, 135, 136, 137, 138, 139, 140, 141, 142, 143, 144, 145, 146, 147, 148, 149, 150, 151, 152, 153, 154, 155, 156, 157, 158, 159, 160, 161, 162, 163, 164, 165, 166, 167, 168, 169, 170, 171, 172, 173, 174, 175, 176, 177, 178, 179, 180, 181, 182, 183, 184, 185, 186, 187, 188, 189, 190, 191, 192, 193, 194, 195, 196, 197, 198, 199, 200, 201, 202, 203, 204, 205, 206, 207, 208, 209, 210, 211, 212, 213, 214, 215, 216, 217, 218, 219, 220, 221, 222, 223, 224, 225, 226, 227, 228, 229, 230, 231, 232, 233, 234, 235, 236, 237, 238, 239, 240, 241, 242, 243, 244, 245, 246, 247, 248, 249, 250, 251, 252, 253, 254, 255, 256, 257, 258, 259, 260, 261, 262, 263, 264, 265, 266, 267, 268, 269, 270, 271, 272, 273, 274, 275, 276, 277, 278, 279, 280, 281, 282, 283, 284, 285, 286, 287, 288, 289, 290, 291, 292, 293, 294, 295, 296, 297, 298, 299, 300, 301, 302, 303, 304, 305, 306, 307, 308, 309, 310, 311, 312, 313, 314, 315, 316, 317, 318, 319, 320, 321, 322, 323, 324, 325, 326, 327, 328, 329, 330, 331, 332, 333, 334, 335, 336, 337, 338, 339, 340, 341, 342, 343, 344, 345, 346, 347, 348, 349, 350, 351, 352, 353, 354, 355, 356, 357, 358, 359, 360, 361, 362, 363, 364, 365, 366, 367, 368, 369, 370, 371, 372, 373, 374, 375, 376, 377, 378, 379, 380, 381, 382, 383, 384, 385, 386, 387, 388, 389, 390, 391, 392, 393, 394, 395, 396, 397, 398, 399, 400, 401, 402, 403, 404, 405, 406, 407, 408, 409, 410, 411, 412, 413, 414, 415, 416, 417, 418, 419, 420, 421, 422, 423, 424, 425, 426, 427, 428, 429, 430, 431, 432, 433, 434, 435, 436, 437, 438, 439, 440, 441, 442, 443, 444, 445, 446, 447, 448, 449, 450, 451, 452, 453, 454, 455, 456, 457, 458, 459, 460, 461, 462, 463, 464, 465, 466, 467, 468, 469, 470, 471, 472, 473, 474, 475, 476, 477, 478, 479, 480, 481, 482, 483, 484, 485, 486, 487, 488, 489, 490, 491, 492, 493, 494, 495, 496, 497, 498, 499, 500, 501, 502, 503, 504, 505, 506, 507, 508, 509, 510, 511, 512, 513, 514, 515, 516, 517, 518, 519, 520, 521, 522, 523, 524, 525, 526, 527, 528, 529, 530, 531, 532, 533, 534, 535, 536, 537, 538, 539, 540, 541, 542, 543, 544, 545, 546, 547, 548, 549, 550, 551, 552, 553, 554, 555, 556, 557, 558, 559, 560, 561, 562, 563, 564, 565, 566, 567, 568, 569, 570, 571, 572, 573, 574, 575, 576, 577, 578, 579, 580, 581, 582, 583, 584, 585, 586, 587, 588, 589, 590, 591, 592, 593, 594, 595, 596, 597, 598, 599, 600, 601, 602, 603, 604, 605, 606, 607, 608, 609, 610, 611, 612, 613, 614, 615, 616, 617, 618, 619, 620, 621, 622, 623, 624, 625, 626, 627, 628, 629, 630, 631, 632, 633, 634, 635, 636, 637, 638, 639, 640, 641, 642, 643, 644, 645, 646, 647, 648, 649, 650, 651, 652, 653, 654, 655, 656, 657, 658, 659, 660, 661, 662, 663, 664, 665, 666, 667, 668, 669, 670, 671, 672, 673, 674, 675, 676, 677, 678, 679, 680, 681, 682, 683, 684, 685, 686, 687, 688, 689, 690, 691, 692, 693, 694, 695, 696, 697, 698, 699, 700, 701, 702, 703, 704, 705, 706, 707, 708, 709, 710, 711, 712, 713, 714, 715, 716, 717, 718, 719, 720, 721, 722, 723, 724, 725, 726, 727, 728, 729, 730, 731, 732, 733, 734, 735, 736, 737, 738, 739, 740, 741, 742, 743, 744, 745, 746, 747, 748, 749, 750, 751, 752, 753, 754, 755, 756, 757, 758, 759, 760, 761, 762, 763, 764, 765, 766, 767, 768, 769, 770, 771, 772, 773, 774, 775, 776, 777, 778, 779, 780, 781, 782, 783, 784, 785, 786, 787, 788, 789, 790, 791, 792, 793, 794, 795, 796, 797, 798, 799, 800, 801, 802, 803, 804, 805, 806, 807, 808, 809, 810, 811, 812, 813, 814, 815, 816, 817, 818, 819, 820, 821, 822, 823, 824, 825, 826, 827, 828, 829, 830, 831, 832, 833, 834, 835, 836, 837, 838, 839, 840, 841, 842, 843, 844, 845, 846, 847, 848, 849, 850, 851, 852, 853, 854, 855, 856, 857, 858, 859, 860, 861, 862, 863, 864, 865, 866, 867, 868, 869, 870, 871, 872, 873, 874, 875, 876, 877, 878, 879, 880, 881, 882, 883, 884, 885, 886, 887, 888, 889, 890, 891, 892, 893, 894, 895, 896, 897, 898, 899, 900, 901, 902, 903, 904, 905, 906, 907, 908, 909, 910, 911, 912, 913, 914, 915, 916, 917, 918, 919, 920, 921, 922, 923, 924, 925, 926, 927, 928, 929, 930, 931, 932, 933, 934, 935, 936, 937, 938, 939, 940, 941, 942, 943, 944, 945, 946, 947, 948, 949, 950, 951, 952, 953, 954, 955, 956, 957, 958, 959, 960, 961, 962, 963, 964, 965, 966, 967, 968, 969, 970, 971, 972, 973, 974, 975, 976, 977, 978, 979, 980, 981, 982, 983, 984, 985, 986, 987, 988, 989, 990, 991, 992, 993, 994, 995, 996, 997, 998, 999, 1000

MAIN CONTRACTOR :
Gammon

STRUCTURAL ENGINEER :
ARUP

FAÇADE CONSULTANT:
MEINHARDT

NOTE :

- ALL DIMENSIONS ARE IN mm.
- ALL ELEVATIONS ARE VIEWED FROM OUTSIDE.
- ALL DIMENSIONS TO BE VERIFIED ON SITE BEFORE FABRICATION.

LEGEND :

- (x1) -- DETAIL MARK NO.
- (x001) -- REFER SHEET NO.
- 1. F.F.L. -- FINISHED FLOOR LEVEL
- 2. S.F.L. -- STRUCTURAL FLOOR LEVEL
- 3. (R) -- REVERSED DETAIL
- (F) -- FIXING LOCATION
- (L) -- FIXING LUG LOCATION

GLASS LEGEND

- GL01 -- 8mm+12mm AIR GAP+10mm THK. I.G.U.
- GL01a -- 8mm+9mm AIR GAP+12mm THK. I.G.U.
- GL03 -- 6mm+12mm AIR GAP+6mm THK. I.G.U.
- GL04 -- 10mm THK. TEMPERED GLASS (PROTECTIVE BARRIER)
- GL05 -- 6mm+12mm AIR GAP+8mm THK. I.G.U.

NO.	DATE	REVISION	BY
A	30/11/2020	REVISION SUBJECT TO ARCH.COMMENT	lvn

JOB NO. : J-852

PROJECT :
PROPOSED RESIDENTIAL DEVELOPMENT
AT 139 - 147 ARGYLE STREET,
NKIL 6005, 6035 R.P., 6036 R.P.,
6037 R.P. & 6038 R.P.

TITLE :
DETAIL FOR
Plenum Box

DATE : 05-Dec-19 SCALE : 1:2

DRAWN BY : MN CHECKED BY : DW

美特鋁質有限公司
MIDI ALUMINIUM FABRICATOR LTD.
Units 6-8, Sunray Industrial Centre, 1/F
610 Cha Kwo Ling Road, Kowloon
Tel:23489211-4 Fax:(852)2727666

DWG NO. : J852-SD-PB-5007 REV. : A

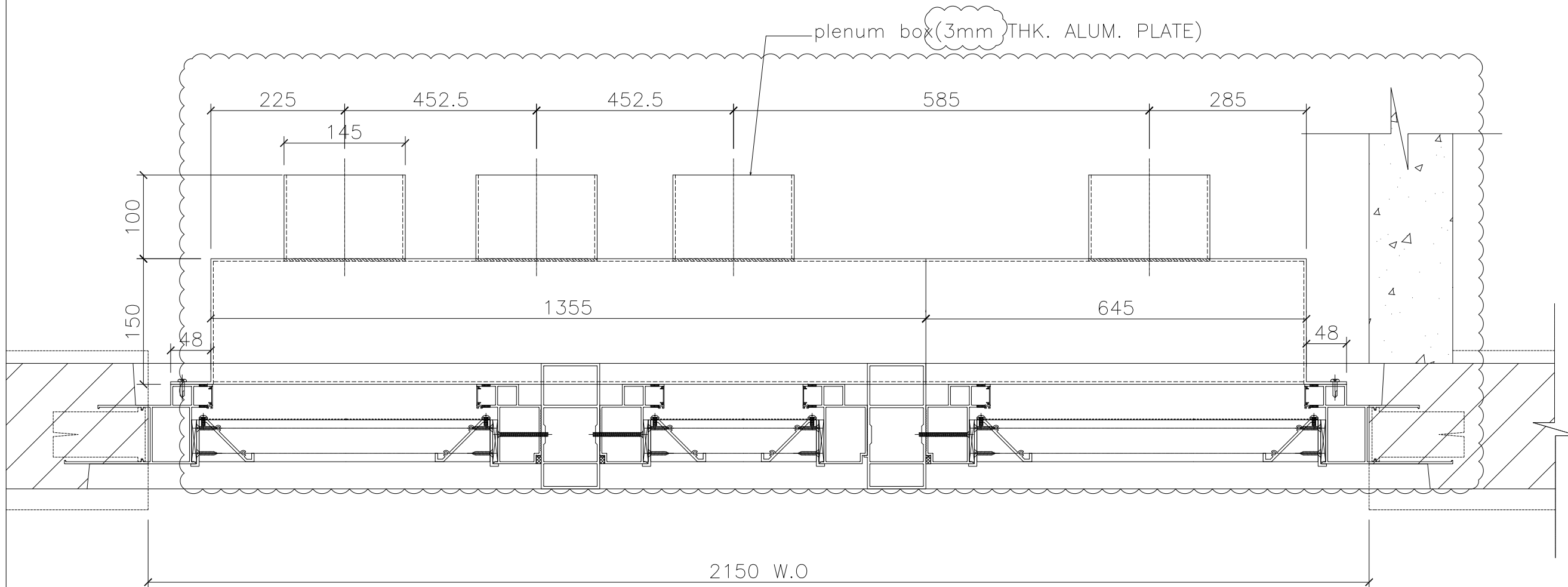

1 HORIZONTAL DETAIL OUTSIDE

B.D. REF :

CLIENT :

ARCHITECT :
AGC
 DESIGN LTD
 181, 182, 183, 184, 185, 186, 187, 188, 189, 190, 191, 192, 193, 194, 195, 196, 197, 198, 199, 200, 201, 202, 203, 204, 205, 206, 207, 208, 209, 210, 211, 212, 213, 214, 215, 216, 217, 218, 219, 220, 221, 222, 223, 224, 225, 226, 227, 228, 229, 230, 231, 232, 233, 234, 235, 236, 237, 238, 239, 240, 241, 242, 243, 244, 245, 246, 247, 248, 249, 250, 251, 252, 253, 254, 255, 256, 257, 258, 259, 260, 261, 262, 263, 264, 265, 266, 267, 268, 269, 270, 271, 272, 273, 274, 275, 276, 277, 278, 279, 280, 281, 282, 283, 284, 285, 286, 287, 288, 289, 290, 291, 292, 293, 294, 295, 296, 297, 298, 299, 300, 301, 302, 303, 304, 305, 306, 307, 308, 309, 310, 311, 312, 313, 314, 315, 316, 317, 318, 319, 320, 321, 322, 323, 324, 325, 326, 327, 328, 329, 330, 331, 332, 333, 334, 335, 336, 337, 338, 339, 340, 341, 342, 343, 344, 345, 346, 347, 348, 349, 350, 351, 352, 353, 354, 355, 356, 357, 358, 359, 360, 361, 362, 363, 364, 365, 366, 367, 368, 369, 370, 371, 372, 373, 374, 375, 376, 377, 378, 379, 380, 381, 382, 383, 384, 385, 386, 387, 388, 389, 390, 391, 392, 393, 394, 395, 396, 397, 398, 399, 400, 401, 402, 403, 404, 405, 406, 407, 408, 409, 410, 411, 412, 413, 414, 415, 416, 417, 418, 419, 420, 421, 422, 423, 424, 425, 426, 427, 428, 429, 430, 431, 432, 433, 434, 435, 436, 437, 438, 439, 440, 441, 442, 443, 444, 445, 446, 447, 448, 449, 450, 451, 452, 453, 454, 455, 456, 457, 458, 459, 460, 461, 462, 463, 464, 465, 466, 467, 468, 469, 470, 471, 472, 473, 474, 475, 476, 477, 478, 479, 480, 481, 482, 483, 484, 485, 486, 487, 488, 489, 490, 491, 492, 493, 494, 495, 496, 497, 498, 499, 500, 501, 502, 503, 504, 505, 506, 507, 508, 509, 510, 511, 512, 513, 514, 515, 516, 517, 518, 519, 520, 521, 522, 523, 524, 525, 526, 527, 528, 529, 530, 531, 532, 533, 534, 535, 536, 537, 538, 539, 540, 541, 542, 543, 544, 545, 546, 547, 548, 549, 550, 551, 552, 553, 554, 555, 556, 557, 558, 559, 560, 561, 562, 563, 564, 565, 566, 567, 568, 569, 570, 571, 572, 573, 574, 575, 576, 577, 578, 579, 580, 581, 582, 583, 584, 585, 586, 587, 588, 589, 590, 591, 592, 593, 594, 595, 596, 597, 598, 599, 600, 601, 602, 603, 604, 605, 606, 607, 608, 609, 610, 611, 612, 613, 614, 615, 616, 617, 618, 619, 620, 621, 622, 623, 624, 625, 626, 627, 628, 629, 630, 631, 632, 633, 634, 635, 636, 637, 638, 639, 640, 641, 642, 643, 644, 645, 646, 647, 648, 649, 650, 651, 652, 653, 654, 655, 656, 657, 658, 659, 660, 661, 662, 663, 664, 665, 666, 667, 668, 669, 670, 671, 672, 673, 674, 675, 676, 677, 678, 679, 680, 681, 682, 683, 684, 685, 686, 687, 688, 689, 690, 691, 692, 693, 694, 695, 696, 697, 698, 699, 700, 701, 702, 703, 704, 705, 706, 707, 708, 709, 710, 711, 712, 713, 714, 715, 716, 717, 718, 719, 720, 721, 722, 723, 724, 725, 726, 727, 728, 729, 730, 731, 732, 733, 734, 735, 736, 737, 738, 739, 740, 741, 742, 743, 744, 745, 746, 747, 748, 749, 750, 751, 752, 753, 754, 755, 756, 757, 758, 759, 760, 761, 762, 763, 764, 765, 766, 767, 768, 769, 770, 771, 772, 773, 774, 775, 776, 777, 778, 779, 780, 781, 782, 783, 784, 785, 786, 787, 788, 789, 790, 791, 792, 793, 794, 795, 796, 797, 798, 799, 800, 801, 802, 803, 804, 805, 806, 807, 808, 809, 810, 811, 812, 813, 814, 815, 816, 817, 818, 819, 820, 821, 822, 823, 824, 825, 826, 827, 828, 829, 830, 831, 832, 833, 834, 835, 836, 837, 838, 839, 840, 841, 842, 843, 844, 845, 846, 847, 848, 849, 850, 851, 852, 853, 854, 855, 856, 857, 858, 859, 860, 861, 862, 863, 864, 865, 866, 867, 868, 869, 870, 871, 872, 873, 874, 875, 876, 877, 878, 879, 880, 881, 882, 883, 884, 885, 886, 887, 888, 889, 890, 891, 892, 893, 894, 895, 896, 897, 898, 899, 900, 901, 902, 903, 904, 905, 906, 907, 908, 909, 910, 911, 912, 913, 914, 915, 916, 917, 918, 919, 920, 921, 922, 923, 924, 925, 926, 927, 928, 929, 930, 931, 932, 933, 934, 935, 936, 937, 938, 939, 940, 941, 942, 943, 944, 945, 946, 947, 948, 949, 950, 951, 952, 953, 954, 955, 956, 957, 958, 959, 960, 961, 962, 963, 964, 965, 966, 967, 968, 969, 970, 971, 972, 973, 974, 975, 976, 977, 978, 979, 980, 981, 982, 983, 984, 985, 986, 987, 988, 989, 990, 991, 992, 993, 994, 995, 996, 997, 998, 999, 1000

MAIN CONTRACTOR :
Gammon

STRUCTURAL ENGINEER :
ARUP

FAÇADE CONSULTANT:
MEINHARDT

NOTE :
 1. ALL DIMENSIONS ARE IN mm.
 2. ALL ELEVATIONS ARE VIEWED FROM OUTSIDE.
 3. ALL DIMENSIONS TO BE VERIFIED ON SITE BEFORE FABRICATION.

LEGEND :
 (X1) -- DETAIL MARK NO.
 (X001) -- REFER SHEET NO.
 1. F.F.L. -- FINISHED FLOOR LEVEL
 2. S.F.L. -- STRUCTURAL FLOOR LEVEL
 3. (R) -- REVERSED DETAIL

NO.	DATE	REVISION	BY
A	30/11/2020	REVISION SUBJECT TO ARCH.COMMENT	lvn

JOB NO. : J-852
 PROJECT :
 PROPOSED RESIDENTIAL DEVELOPMENT
 AT 139 - 147 ARGYLE STREET,
 NKIL 6005, 6035 R.P., 6036 R.P.,
 6037 R.P. & 6038 R.P.

TITLE :
 DETAIL FOR
 Plenum Box

DATE : 05-Dec-19 SCALE : 1:2

DRAWN BY : MN CHECKED BY : DW

美特鋁質有限公司
MIDI ALUMINIUM FABRICATOR LTD.
 Units 6-8, Sunray Industrial Centre, 1/F
 610 Cha Kwo Ling Road, Kowloon
 Tel:23489211-4 Fax:(852)2727666

DWG NO. : J852-SD-PB-5008 REV. : A

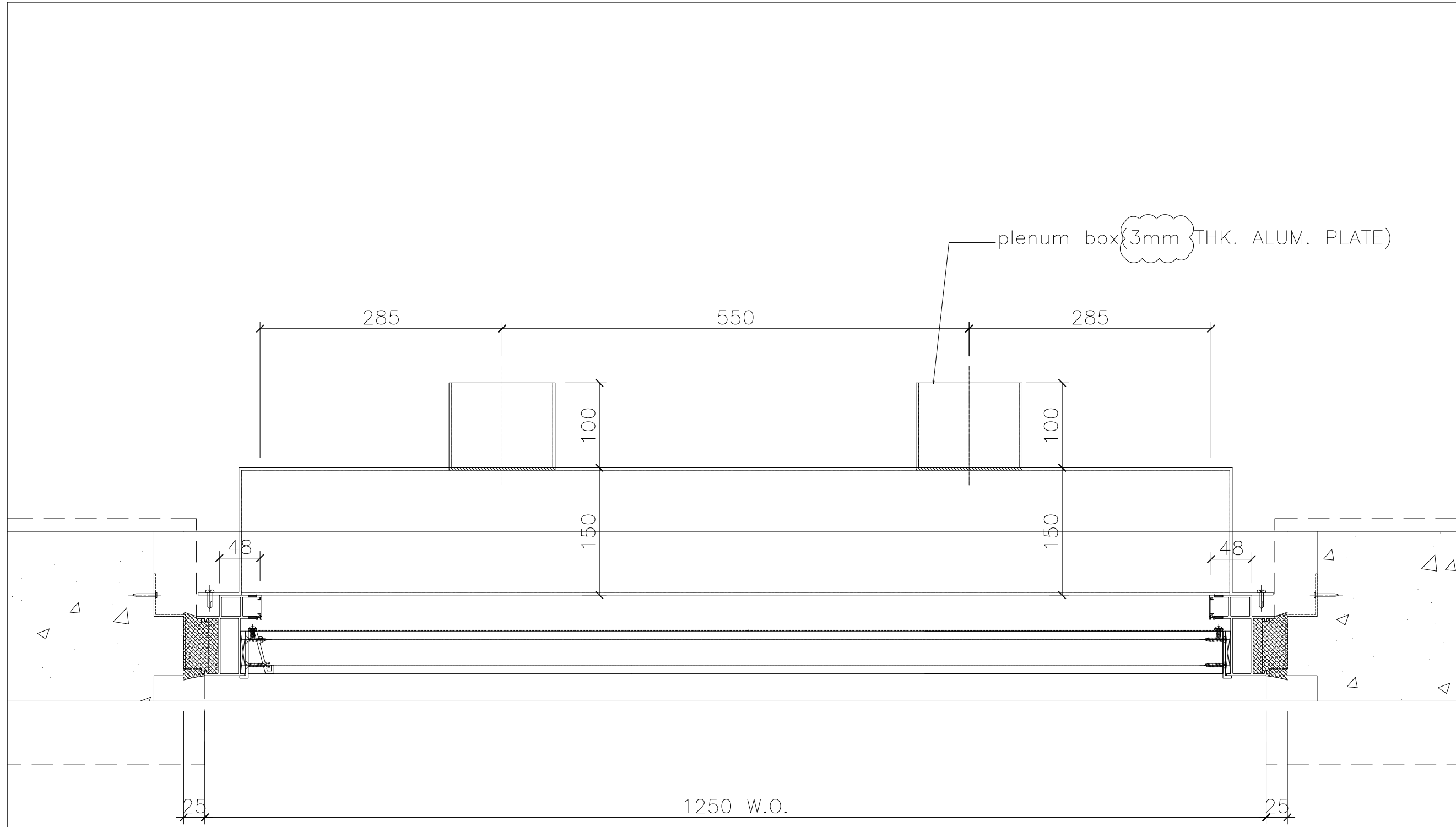

1 HORIZONTAL DETAIL
SCALE 1:1

OUTSIDE

B.D. REF :

CLIENT :

ARCHITECT :
AGC DESIGN LTD
AGC DESIGN LTD
101, 102, 103, 104, 105, 106, 107, 108, 109, 110, 111, 112, 113, 114, 115, 116, 117, 118, 119, 120, 121, 122, 123, 124, 125, 126, 127, 128, 129, 130, 131, 132, 133, 134, 135, 136, 137, 138, 139, 140, 141, 142, 143, 144, 145, 146, 147, 148, 149, 150, 151, 152, 153, 154, 155, 156, 157, 158, 159, 160, 161, 162, 163, 164, 165, 166, 167, 168, 169, 170, 171, 172, 173, 174, 175, 176, 177, 178, 179, 180, 181, 182, 183, 184, 185, 186, 187, 188, 189, 190, 191, 192, 193, 194, 195, 196, 197, 198, 199, 200, 201, 202, 203, 204, 205, 206, 207, 208, 209, 210, 211, 212, 213, 214, 215, 216, 217, 218, 219, 220, 221, 222, 223, 224, 225, 226, 227, 228, 229, 230, 231, 232, 233, 234, 235, 236, 237, 238, 239, 240, 241, 242, 243, 244, 245, 246, 247, 248, 249, 250, 251, 252, 253, 254, 255, 256, 257, 258, 259, 260, 261, 262, 263, 264, 265, 266, 267, 268, 269, 270, 271, 272, 273, 274, 275, 276, 277, 278, 279, 280, 281, 282, 283, 284, 285, 286, 287, 288, 289, 290, 291, 292, 293, 294, 295, 296, 297, 298, 299, 300, 301, 302, 303, 304, 305, 306, 307, 308, 309, 310, 311, 312, 313, 314, 315, 316, 317, 318, 319, 320, 321, 322, 323, 324, 325, 326, 327, 328, 329, 330, 331, 332, 333, 334, 335, 336, 337, 338, 339, 340, 341, 342, 343, 344, 345, 346, 347, 348, 349, 350, 351, 352, 353, 354, 355, 356, 357, 358, 359, 360, 361, 362, 363, 364, 365, 366, 367, 368, 369, 370, 371, 372, 373, 374, 375, 376, 377, 378, 379, 380, 381, 382, 383, 384, 385, 386, 387, 388, 389, 390, 391, 392, 393, 394, 395, 396, 397, 398, 399, 400, 401, 402, 403, 404, 405, 406, 407, 408, 409, 410, 411, 412, 413, 414, 415, 416, 417, 418, 419, 420, 421, 422, 423, 424, 425, 426, 427, 428, 429, 430, 431, 432, 433, 434, 435, 436, 437, 438, 439, 440, 441, 442, 443, 444, 445, 446, 447, 448, 449, 450, 451, 452, 453, 454, 455, 456, 457, 458, 459, 460, 461, 462, 463, 464, 465, 466, 467, 468, 469, 470, 471, 472, 473, 474, 475, 476, 477, 478, 479, 480, 481, 482, 483, 484, 485, 486, 487, 488, 489, 490, 491, 492, 493, 494, 495, 496, 497, 498, 499, 500, 501, 502, 503, 504, 505, 506, 507, 508, 509, 510, 511, 512, 513, 514, 515, 516, 517, 518, 519, 520, 521, 522, 523, 524, 525, 526, 527, 528, 529, 530, 531, 532, 533, 534, 535, 536, 537, 538, 539, 540, 541, 542, 543, 544, 545, 546, 547, 548, 549, 550, 551, 552, 553, 554, 555, 556, 557, 558, 559, 560, 561, 562, 563, 564, 565, 566, 567, 568, 569, 570, 571, 572, 573, 574, 575, 576, 577, 578, 579, 580, 581, 582, 583, 584, 585, 586, 587, 588, 589, 590, 591, 592, 593, 594, 595, 596, 597, 598, 599, 600, 601, 602, 603, 604, 605, 606, 607, 608, 609, 610, 611, 612, 613, 614, 615, 616, 617, 618, 619, 620, 621, 622, 623, 624, 625, 626, 627, 628, 629, 630, 631, 632, 633, 634, 635, 636, 637, 638, 639, 640, 641, 642, 643, 644, 645, 646, 647, 648, 649, 650, 651, 652, 653, 654, 655, 656, 657, 658, 659, 660, 661, 662, 663, 664, 665, 666, 667, 668, 669, 670, 671, 672, 673, 674, 675, 676, 677, 678, 679, 680, 681, 682, 683, 684, 685, 686, 687, 688, 689, 690, 691, 692, 693, 694, 695, 696, 697, 698, 699, 700, 701, 702, 703, 704, 705, 706, 707, 708, 709, 710, 711, 712, 713, 714, 715, 716, 717, 718, 719, 720, 721, 722, 723, 724, 725, 726, 727, 728, 729, 730, 731, 732, 733, 734, 735, 736, 737, 738, 739, 740, 741, 742, 743, 744, 745, 746, 747, 748, 749, 750, 751, 752, 753, 754, 755, 756, 757, 758, 759, 760, 761, 762, 763, 764, 765, 766, 767, 768, 769, 770, 771, 772, 773, 774, 775, 776, 777, 778, 779, 780, 781, 782, 783, 784, 785, 786, 787, 788, 789, 790, 791, 792, 793, 794, 795, 796, 797, 798, 799, 800, 801, 802, 803, 804, 805, 806, 807, 808, 809, 810, 811, 812, 813, 814, 815, 816, 817, 818, 819, 820, 821, 822, 823, 824, 825, 826, 827, 828, 829, 830, 831, 832, 833, 834, 835, 836, 837, 838, 839, 840, 841, 842, 843, 844, 845, 846, 847, 848, 849, 850, 851, 852, 853, 854, 855, 856, 857, 858, 859, 860, 861, 862, 863, 864, 865, 866, 867, 868, 869, 870, 871, 872, 873, 874, 875, 876, 877, 878, 879, 880, 881, 882, 883, 884, 885, 886, 887, 888, 889, 890, 891, 892, 893, 894, 895, 896, 897, 898, 899, 900, 901, 902, 903, 904, 905, 906, 907, 908, 909, 910, 911, 912, 913, 914, 915, 916, 917, 918, 919, 920, 921, 922, 923, 924, 925, 926, 927, 928, 929, 930, 931, 932, 933, 934, 935, 936, 937, 938, 939, 940, 941, 942, 943, 944, 945, 946, 947, 948, 949, 950, 951, 952, 953, 954, 955, 956, 957, 958, 959, 960, 961, 962, 963, 964, 965, 966, 967, 968, 969, 970, 971, 972, 973, 974, 975, 976, 977, 978, 979, 980, 981, 982, 983, 984, 985, 986, 987, 988, 989, 990, 991, 992, 993, 994, 995, 996, 997, 998, 999, 1000

MAIN CONTRACTOR :
Gammon

STRUCTURAL ENGINEER :
ARUP

FACADE CONSULTANT :
MEINHARDT

NOTE :
1. ALL DIMENSIONS ARE IN mm.
2. ALL ELEVATIONS ARE VIEWED FROM OUTSIDE.
3. ALL DIMENSIONS TO BE VERIFIED ON SITE BEFORE FABRICATION.

LEGEND :
x1 — DETAIL MARK NO.
x001 — REFER SHEET NO.
1. F.F.L. — FINISHED FLOOR LEVEL
2. S.F.L. — STRUCTURAL FLOOR LEVEL
3. (R) — REVERSED DETAIL
— FIXING LOCATION
— FIXING LUG LOCATION

GLASS LEGEND
GL01 — 8mm+12mm AIR GAP+10mm THK. I.G.U.
GL01a — 8mm+9mm AIR GAP+12mm THK. I.G.U.
GL03 — 6mm+12mm AIR GAP+6mm THK. I.G.U.
GL04 — 10mm THK. TEMPERED GLASS (PROTECTIVE BARRIER)
GL05 — 6mm+12mm AIR GAP+8mm THK. I.G.U.

NO.	DATE	REVISED	BY

JOB NO. : J-852
PROJECT : PROPOSED RESIDENTIAL DEVELOPMENT
AT 139 - 147 ARGYLE STREET,
NKIL 6005, 6035 R.P., 6036 R.P.,
6037 R.P. & 6038 R.P.

TITLE :
DETAIL FOR
Plenum Box

DATE : 05-Dec-19 SCALE : 1:2

DRAWN BY : MN CHECKED BY : DW

美特鋁質有限公司
MIDI ALUMINIUM FABRICATOR LTD.
Units 6-8, Sunray Industrial Centre, 1/F
610 Cha Kwo Ling Road, Kowloon
Tel:23489211-4 Fax:(852)2727666

DWG NO. : J852-SD-PB-5009 REV. : -

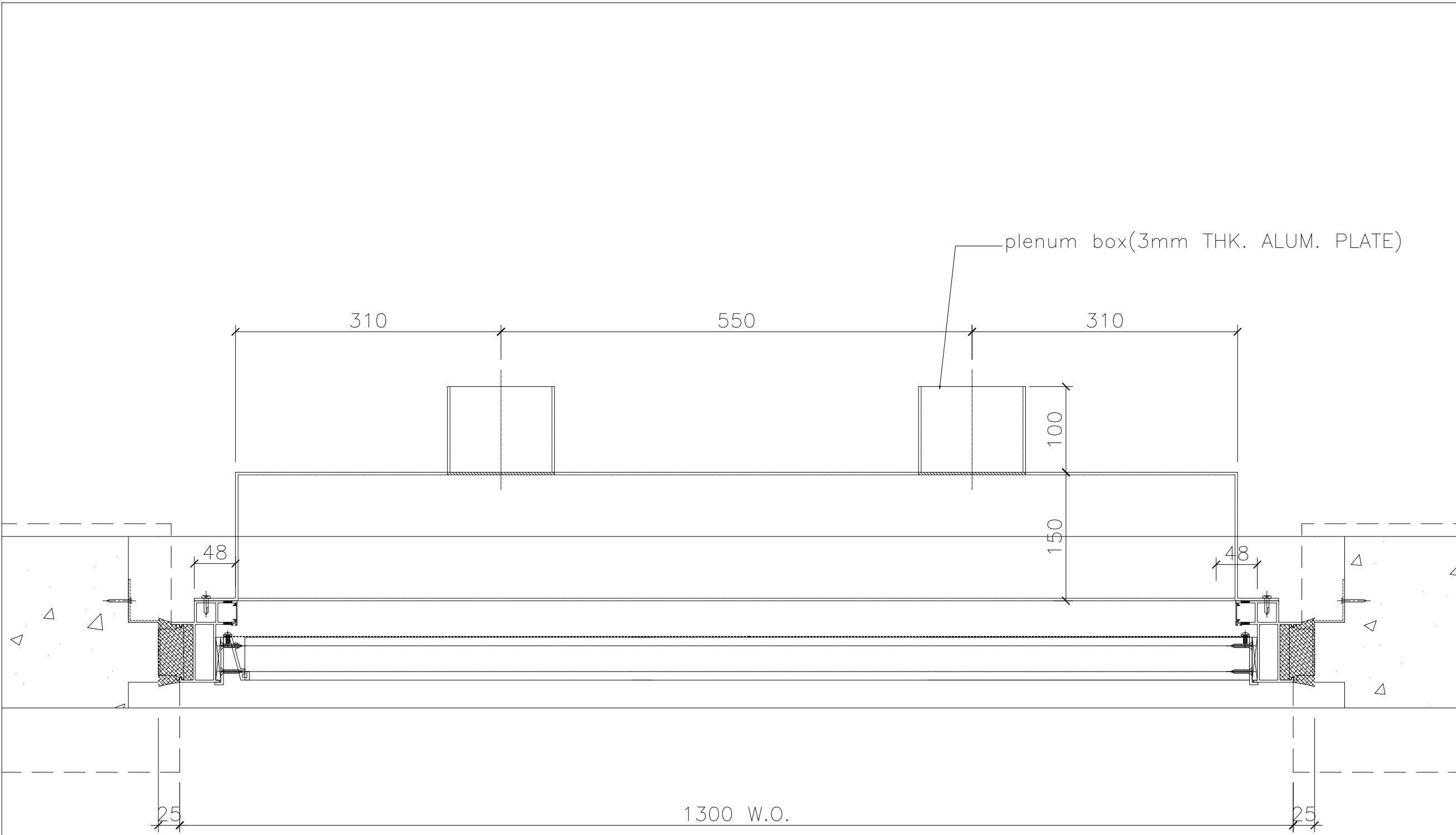

plenum box(3mm THK. ALUM. PLATE)

310

550

310

100

150

48

48

25

1300 W.O.

25

1 HORIZONTAL DETAIL
SCALE 1:1

OUTSIDE

B.D. REF :

CLIENT :

ARCHITECT :
AGC DESIGN LTD
 10/F, 107, Queen Mary Road, 220, Hong Kong
 Tel: (852) 2771 1111 Fax: (852) 2771 1112 Email: agc@agc.com.hk

MAIN CONTRACTOR :
Gammon

STRUCTURAL ENGINEER :
ARUP

FACADE CONSULTANT:
MEINHARDT

NOTE :
 1. ALL DIMENSIONS ARE IN mm.
 2. ALL ELEVATIONS ARE VIEWED FROM OUTSIDE.
 3. ALL DIMENSIONS TO BE VERIFIED ON SITE BEFORE FABRICATION.

LEGEND :
 (x1) -- DETAIL MARK NO.
 (x001) -- REFER SHEET NO.
 1. F.F.L. -- FINISHED FLOOR LEVEL
 2. S.F.L. -- STRUCTURAL FLOOR LEVEL
 3. (R) -- REVERSED DETAIL
 -- FIXING LOCATION
 -- FIXING LUG LOCATION

GLASS LEGEND
 GL01 -- 8mm+12mm AIR GAP+10mm THK. I.G.U.
 GL01a -- 8mm+9mm AIR GAP+12mm THK. I.G.U.
 GL03 -- 6mm+12mm AIR GAP+6mm THK. I.G.U.
 GL04 -- 10mm THK. TEMPERED GLASS (PROTECTIVE BARRIER)
 GL05 -- 6mm+12mm AIR GAP+8mm THK. I.G.U.

NO.	DATE	REVISED	BY
JOB NO. : J-852			
PROJECT : PROPOSED RESIDENTIAL DEVELOPMENT AT 139 - 147 ARGYLE STREET, NKIL 6005, 6035 R.P., 6036 R.P., 6037 R.P. & 6038 R.P.			
TITLE : DETAIL FOR Plenum Box			
DATE : 05-Dec-19		SCALE : 1:2	
DRAWN BY : MN		CHECKED BY : DW	
美特鋁質有限公司 MIDI ALUMINIUM FABRICATOR LTD. Units 6-8, Sunray Industrial Centre, 1/F 610 Cha Kwo Ling Road, Kowloon Tel:23489211-4 Fax:(852)2727666			
DWG NO. : J852-SD-PB-5010			REV. : -

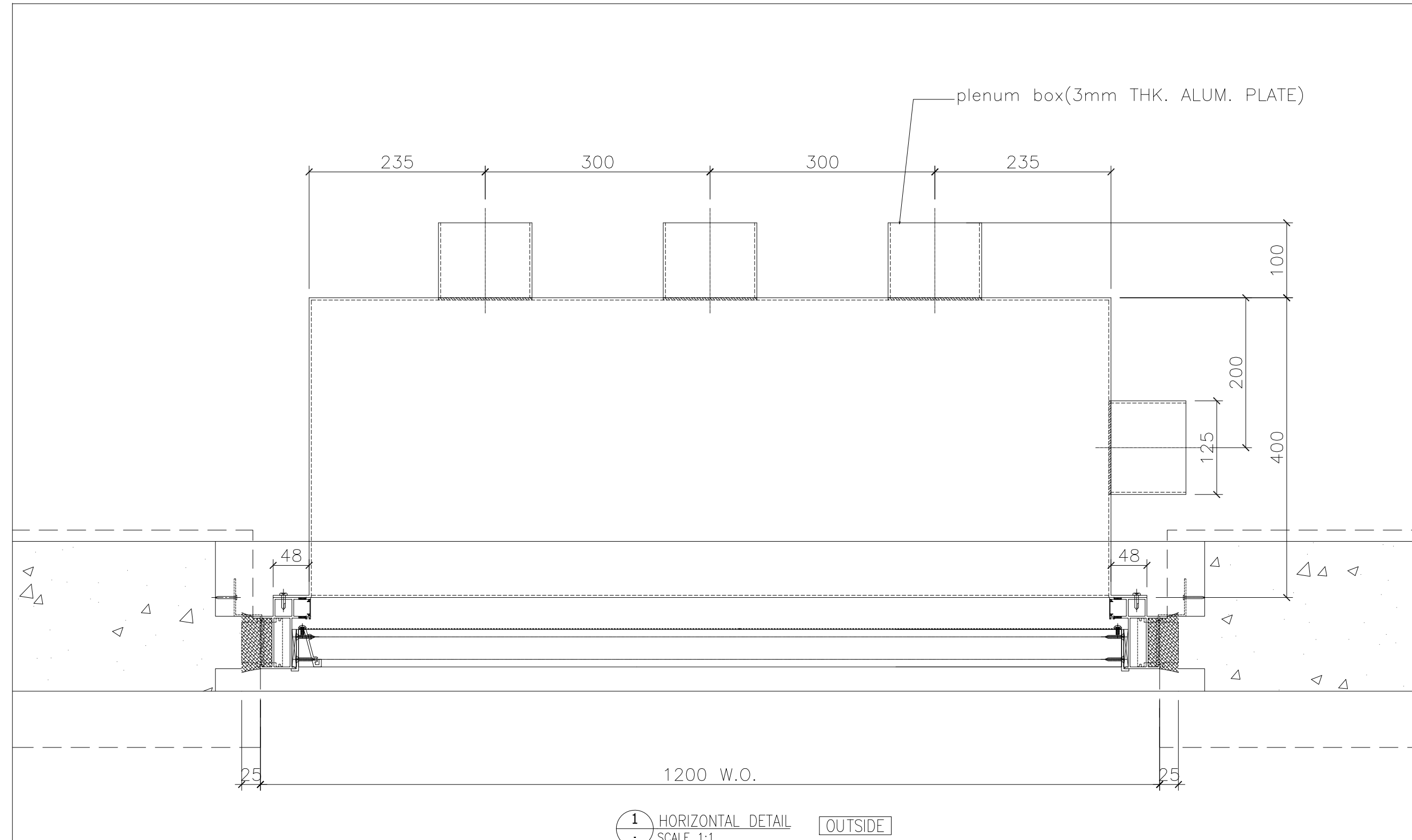

1 HORIZONTAL DETAIL
SCALE 1:1

OUTSIDE

B.D. REF :

CLIENT :

ARCHITECT :
AGC
DESIGN LTD

MAIN CONTRACTOR :
Gammon

STRUCTURAL ENGINEER :
ARUP

FACADE CONSULTANT:
MEINHARDT

NOTE :
1. ALL DIMENSIONS ARE IN mm.
2. ALL ELEVATIONS ARE VIEWED FROM OUTSIDE.
3. ALL DIMENSIONS TO BE VERIFIED ON SITE BEFORE FABRICATION.

LEGEND :
 (X1) --- DETAIL MARK NO.
 (X001) --- REFER SHEET NO.
 1. F.F.L. --- FINISHED FLOOR LEVEL
 2. S.F.L. --- STRUCTURAL FLOOR LEVEL
 3. (R) --- REVERSED DETAIL

NO.	DATE	REVISED	BY

JOB NO. : J-852
 PROJECT :
 PROPOSED RESIDENTIAL DEVELOPMENT
 AT 139 - 147 ARGYLE STREET,
 NKIL 6005, 6035 R.P., 6036 R.P.,
 6037 R.P. & 6038 R.P.

TITLE :
 DETAIL FOR
 Plenum Box

DATE : 05-Dec-19 SCALE : 1:2

DRAWN BY : MN CHECKED BY : DW

美特鋁質有限公司
MIDI ALUMINIUM FABRICATOR LTD.
 Units 6-8, Sunray Industrial Centre, 1/F
 610 Cha Kwo Ling Road, Kowloon
 Tel:23489211-4 Fax:(852)2727666

DWG NO. : J852-SD-PB-5011 REV. : -

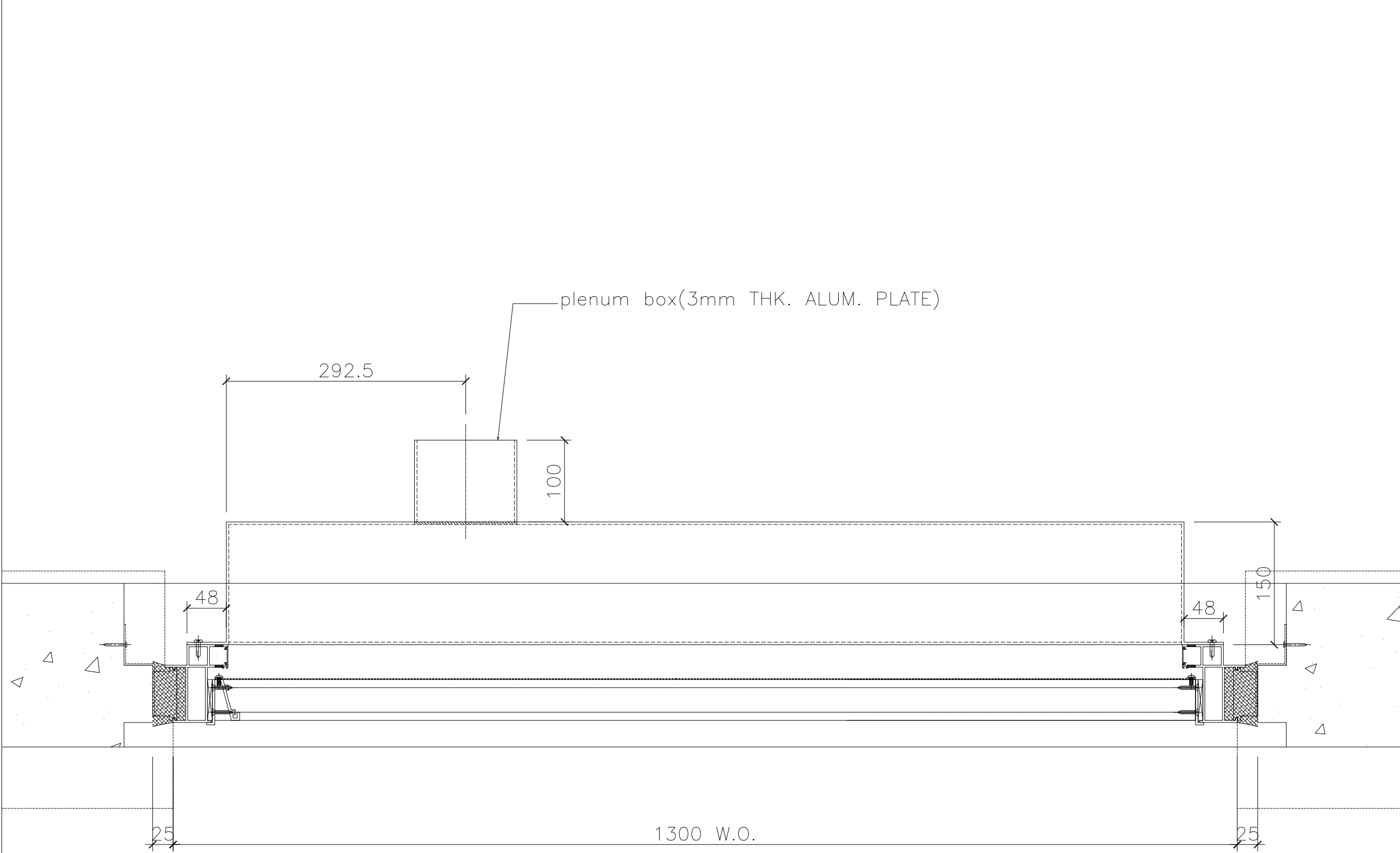

1 HORIZONTAL DETAIL
SCALE 1:1

OUTSIDE

B.D. REF :

CLIENT :

ARCHITECT :
AGC DESIGN LTD
 181, 182, 183, 184, 185, 186, 187, 188, 189, 190, 191, 192, 193, 194, 195, 196, 197, 198, 199, 200, 201, 202, 203, 204, 205, 206, 207, 208, 209, 210, 211, 212, 213, 214, 215, 216, 217, 218, 219, 220, 221, 222, 223, 224, 225, 226, 227, 228, 229, 230, 231, 232, 233, 234, 235, 236, 237, 238, 239, 240, 241, 242, 243, 244, 245, 246, 247, 248, 249, 250, 251, 252, 253, 254, 255, 256, 257, 258, 259, 260, 261, 262, 263, 264, 265, 266, 267, 268, 269, 270, 271, 272, 273, 274, 275, 276, 277, 278, 279, 280, 281, 282, 283, 284, 285, 286, 287, 288, 289, 290, 291, 292, 293, 294, 295, 296, 297, 298, 299, 300, 301, 302, 303, 304, 305, 306, 307, 308, 309, 310, 311, 312, 313, 314, 315, 316, 317, 318, 319, 320, 321, 322, 323, 324, 325, 326, 327, 328, 329, 330, 331, 332, 333, 334, 335, 336, 337, 338, 339, 340, 341, 342, 343, 344, 345, 346, 347, 348, 349, 350, 351, 352, 353, 354, 355, 356, 357, 358, 359, 360, 361, 362, 363, 364, 365, 366, 367, 368, 369, 370, 371, 372, 373, 374, 375, 376, 377, 378, 379, 380, 381, 382, 383, 384, 385, 386, 387, 388, 389, 390, 391, 392, 393, 394, 395, 396, 397, 398, 399, 400, 401, 402, 403, 404, 405, 406, 407, 408, 409, 410, 411, 412, 413, 414, 415, 416, 417, 418, 419, 420, 421, 422, 423, 424, 425, 426, 427, 428, 429, 430, 431, 432, 433, 434, 435, 436, 437, 438, 439, 440, 441, 442, 443, 444, 445, 446, 447, 448, 449, 450, 451, 452, 453, 454, 455, 456, 457, 458, 459, 460, 461, 462, 463, 464, 465, 466, 467, 468, 469, 470, 471, 472, 473, 474, 475, 476, 477, 478, 479, 480, 481, 482, 483, 484, 485, 486, 487, 488, 489, 490, 491, 492, 493, 494, 495, 496, 497, 498, 499, 500, 501, 502, 503, 504, 505, 506, 507, 508, 509, 510, 511, 512, 513, 514, 515, 516, 517, 518, 519, 520, 521, 522, 523, 524, 525, 526, 527, 528, 529, 530, 531, 532, 533, 534, 535, 536, 537, 538, 539, 540, 541, 542, 543, 544, 545, 546, 547, 548, 549, 550, 551, 552, 553, 554, 555, 556, 557, 558, 559, 560, 561, 562, 563, 564, 565, 566, 567, 568, 569, 570, 571, 572, 573, 574, 575, 576, 577, 578, 579, 580, 581, 582, 583, 584, 585, 586, 587, 588, 589, 590, 591, 592, 593, 594, 595, 596, 597, 598, 599, 600, 601, 602, 603, 604, 605, 606, 607, 608, 609, 610, 611, 612, 613, 614, 615, 616, 617, 618, 619, 620, 621, 622, 623, 624, 625, 626, 627, 628, 629, 630, 631, 632, 633, 634, 635, 636, 637, 638, 639, 640, 641, 642, 643, 644, 645, 646, 647, 648, 649, 650, 651, 652, 653, 654, 655, 656, 657, 658, 659, 660, 661, 662, 663, 664, 665, 666, 667, 668, 669, 670, 671, 672, 673, 674, 675, 676, 677, 678, 679, 680, 681, 682, 683, 684, 685, 686, 687, 688, 689, 690, 691, 692, 693, 694, 695, 696, 697, 698, 699, 700, 701, 702, 703, 704, 705, 706, 707, 708, 709, 710, 711, 712, 713, 714, 715, 716, 717, 718, 719, 720, 721, 722, 723, 724, 725, 726, 727, 728, 729, 730, 731, 732, 733, 734, 735, 736, 737, 738, 739, 740, 741, 742, 743, 744, 745, 746, 747, 748, 749, 750, 751, 752, 753, 754, 755, 756, 757, 758, 759, 760, 761, 762, 763, 764, 765, 766, 767, 768, 769, 770, 771, 772, 773, 774, 775, 776, 777, 778, 779, 780, 781, 782, 783, 784, 785, 786, 787, 788, 789, 790, 791, 792, 793, 794, 795, 796, 797, 798, 799, 800, 801, 802, 803, 804, 805, 806, 807, 808, 809, 810, 811, 812, 813, 814, 815, 816, 817, 818, 819, 820, 821, 822, 823, 824, 825, 826, 827, 828, 829, 830, 831, 832, 833, 834, 835, 836, 837, 838, 839, 840, 841, 842, 843, 844, 845, 846, 847, 848, 849, 850, 851, 852, 853, 854, 855, 856, 857, 858, 859, 860, 861, 862, 863, 864, 865, 866, 867, 868, 869, 870, 871, 872, 873, 874, 875, 876, 877, 878, 879, 880, 881, 882, 883, 884, 885, 886, 887, 888, 889, 890, 891, 892, 893, 894, 895, 896, 897, 898, 899, 900, 901, 902, 903, 904, 905, 906, 907, 908, 909, 910, 911, 912, 913, 914, 915, 916, 917, 918, 919, 920, 921, 922, 923, 924, 925, 926, 927, 928, 929, 930, 931, 932, 933, 934, 935, 936, 937, 938, 939, 940, 941, 942, 943, 944, 945, 946, 947, 948, 949, 950, 951, 952, 953, 954, 955, 956, 957, 958, 959, 960, 961, 962, 963, 964, 965, 966, 967, 968, 969, 970, 971, 972, 973, 974, 975, 976, 977, 978, 979, 980, 981, 982, 983, 984, 985, 986, 987, 988, 989, 990, 991, 992, 993, 994, 995, 996, 997, 998, 999, 1000

MAIN CONTRACTOR :
Gammon

STRUCTURAL ENGINEER :
ARUP

FACADE CONSULTANT:
MEINHARDT

NOTE :
 1. ALL DIMENSIONS ARE IN mm.
 2. ALL ELEVATIONS ARE VIEWED FROM OUTSIDE.
 3. ALL DIMENSIONS TO BE VERIFIED ON SITE BEFORE FABRICATION.

LEGEND :
 x1 -- DETAIL MARK NO.
 x001 -- REFER SHEET NO.
 1. F.F.L. -- FINISHED FLOOR LEVEL
 2. S.F.L. -- STRUCTURAL FLOOR LEVEL
 3. (R) -- REVERSED DETAIL
 -- FIXING LOCATION
 -- FIXING LUG LOCATION
 GLASS LEGEND
 GL01 -- 8mm+12mm AIR GAP+10mm THK. I.G.U.
 GL01a -- 8mm+9mm AIR GAP+12mm THK. I.G.U.
 GL03 -- 6mm+12mm AIR GAP+6mm THK. I.G.U.
 GL04 -- 10mm THK. TEMPERED GLASS (PROTECTIVE BARRIER)
 GL05 -- 6mm+12mm AIR GAP+8mm THK. I.G.U.

NO.	DATE	REVISED	BY

JOB NO. : J-852
 PROJECT :
 PROPOSED RESIDENTIAL DEVELOPMENT
 AT 139 - 147 ARGYLE STREET,
 NKIL 6005, 6035 R.P., 6036 R.P.,
 6037 R.P. & 6038 R.P.

TITLE :
 DETAIL FOR
 Plenum Box

DATE : 05-Dec-19 SCALE : 1:2

DRAWN BY : MN CHECKED BY : DW

美特鋁質有限公司
MIDI ALUMINIUM FABRICATOR LTD.
 Units 6-8, Sunray Industrial Centre, 1/F
 610 Cha Kwo Ling Road, Kowloon
 Tel:23489211-4 Fax:(852)2727666

DWG NO. : J852-SD-PB-5012 REV. : -

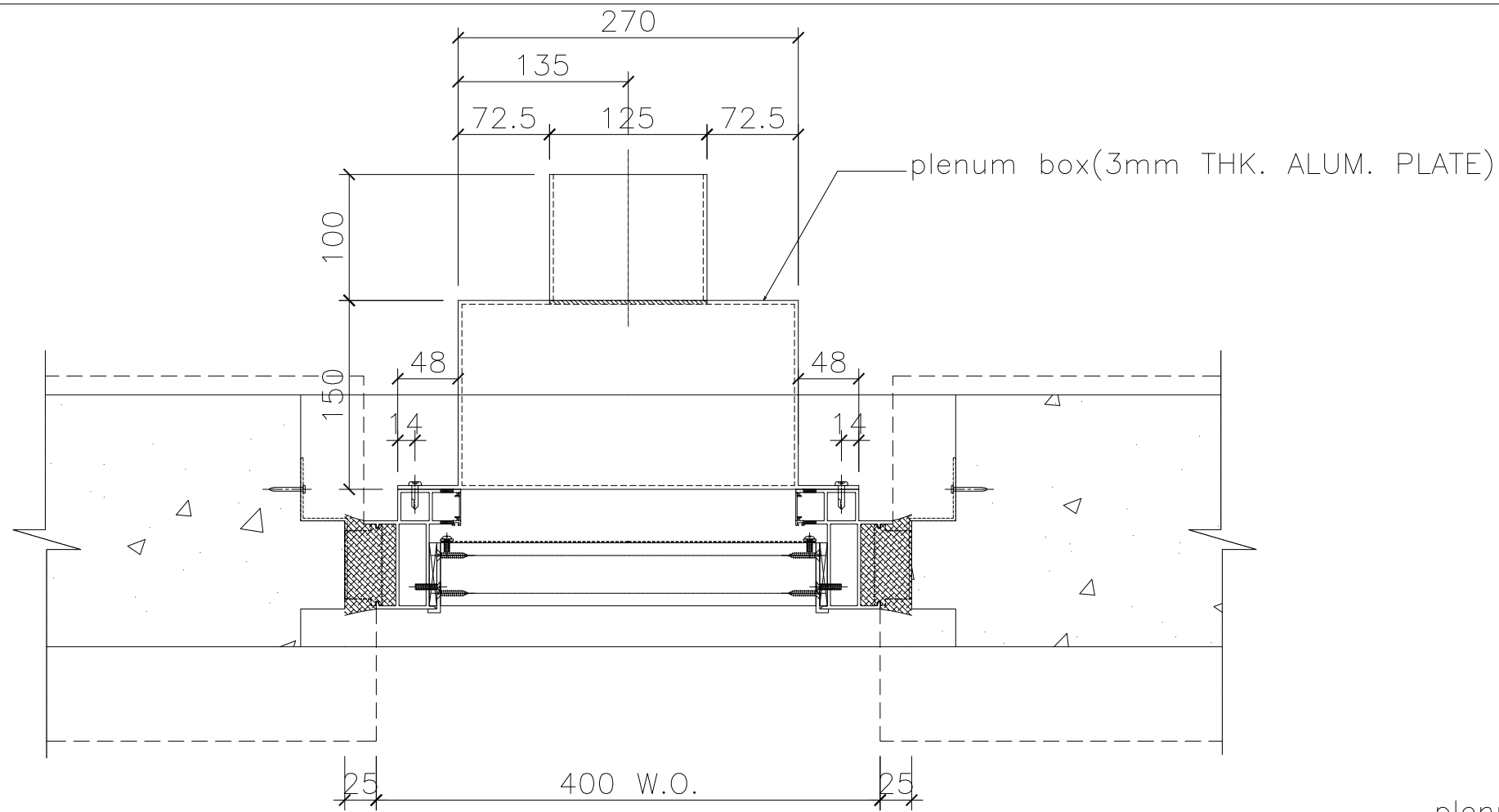

1 HORIZONTAL DETAIL SCALE 1:1 OUTSIDE

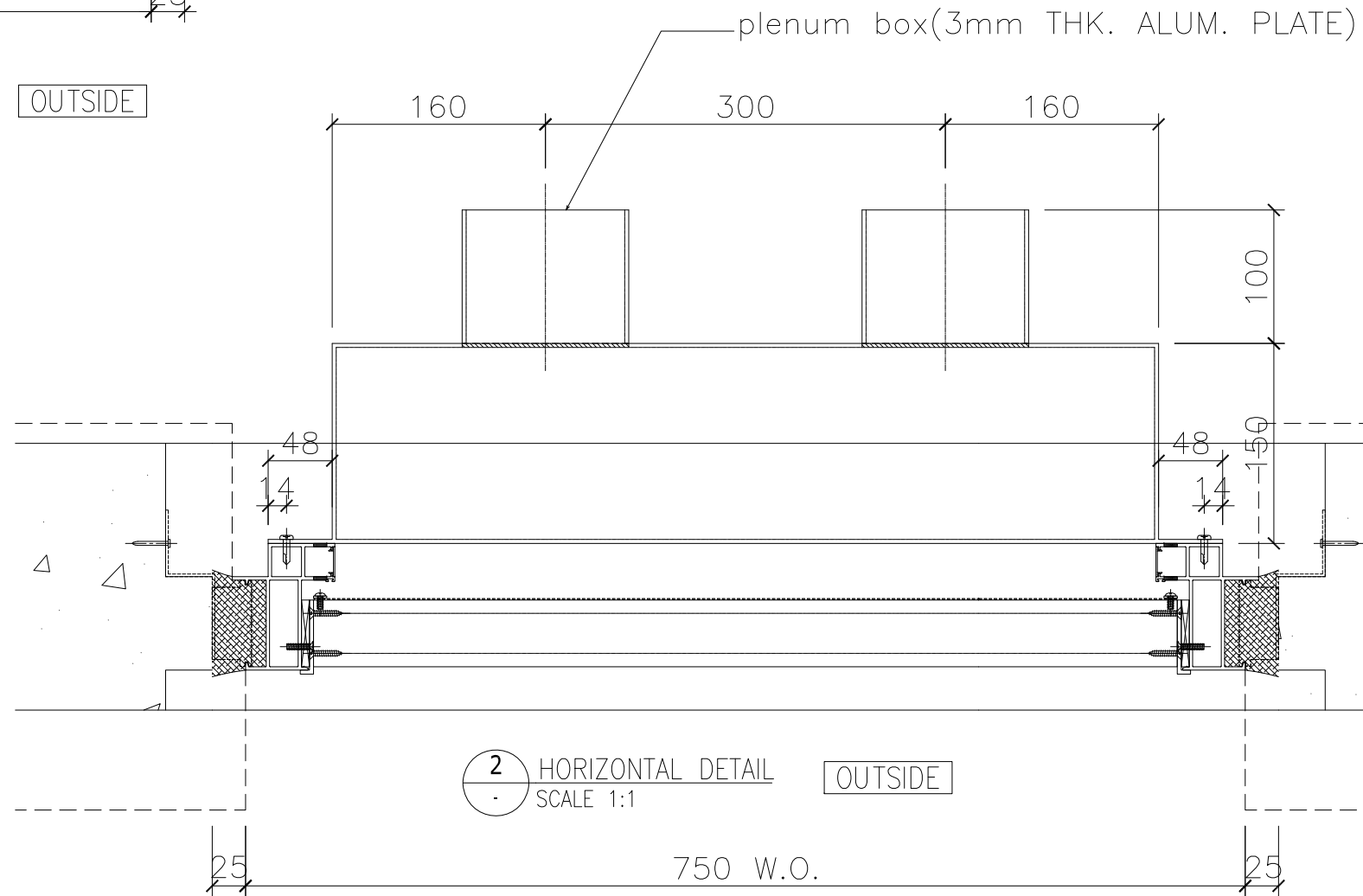

2 HORIZONTAL DETAIL SCALE 1:1 OUTSIDE

B.D. REF :

CLIENT :

ARCHITECT :
AGC DESIGN LTD
 181, 182, 183, 184, 185, 186, 187, 188, 189, 190, 191, 192, 193, 194, 195, 196, 197, 198, 199, 200, 201, 202, 203, 204, 205, 206, 207, 208, 209, 210, 211, 212, 213, 214, 215, 216, 217, 218, 219, 220, 221, 222, 223, 224, 225, 226, 227, 228, 229, 230, 231, 232, 233, 234, 235, 236, 237, 238, 239, 240, 241, 242, 243, 244, 245, 246, 247, 248, 249, 250, 251, 252, 253, 254, 255, 256, 257, 258, 259, 260, 261, 262, 263, 264, 265, 266, 267, 268, 269, 270, 271, 272, 273, 274, 275, 276, 277, 278, 279, 280, 281, 282, 283, 284, 285, 286, 287, 288, 289, 290, 291, 292, 293, 294, 295, 296, 297, 298, 299, 300, 301, 302, 303, 304, 305, 306, 307, 308, 309, 310, 311, 312, 313, 314, 315, 316, 317, 318, 319, 320, 321, 322, 323, 324, 325, 326, 327, 328, 329, 330, 331, 332, 333, 334, 335, 336, 337, 338, 339, 340, 341, 342, 343, 344, 345, 346, 347, 348, 349, 350, 351, 352, 353, 354, 355, 356, 357, 358, 359, 360, 361, 362, 363, 364, 365, 366, 367, 368, 369, 370, 371, 372, 373, 374, 375, 376, 377, 378, 379, 380, 381, 382, 383, 384, 385, 386, 387, 388, 389, 390, 391, 392, 393, 394, 395, 396, 397, 398, 399, 400, 401, 402, 403, 404, 405, 406, 407, 408, 409, 410, 411, 412, 413, 414, 415, 416, 417, 418, 419, 420, 421, 422, 423, 424, 425, 426, 427, 428, 429, 430, 431, 432, 433, 434, 435, 436, 437, 438, 439, 440, 441, 442, 443, 444, 445, 446, 447, 448, 449, 450, 451, 452, 453, 454, 455, 456, 457, 458, 459, 460, 461, 462, 463, 464, 465, 466, 467, 468, 469, 470, 471, 472, 473, 474, 475, 476, 477, 478, 479, 480, 481, 482, 483, 484, 485, 486, 487, 488, 489, 490, 491, 492, 493, 494, 495, 496, 497, 498, 499, 500, 501, 502, 503, 504, 505, 506, 507, 508, 509, 510, 511, 512, 513, 514, 515, 516, 517, 518, 519, 520, 521, 522, 523, 524, 525, 526, 527, 528, 529, 530, 531, 532, 533, 534, 535, 536, 537, 538, 539, 540, 541, 542, 543, 544, 545, 546, 547, 548, 549, 550, 551, 552, 553, 554, 555, 556, 557, 558, 559, 560, 561, 562, 563, 564, 565, 566, 567, 568, 569, 570, 571, 572, 573, 574, 575, 576, 577, 578, 579, 580, 581, 582, 583, 584, 585, 586, 587, 588, 589, 590, 591, 592, 593, 594, 595, 596, 597, 598, 599, 600, 601, 602, 603, 604, 605, 606, 607, 608, 609, 610, 611, 612, 613, 614, 615, 616, 617, 618, 619, 620, 621, 622, 623, 624, 625, 626, 627, 628, 629, 630, 631, 632, 633, 634, 635, 636, 637, 638, 639, 640, 641, 642, 643, 644, 645, 646, 647, 648, 649, 650, 651, 652, 653, 654, 655, 656, 657, 658, 659, 660, 661, 662, 663, 664, 665, 666, 667, 668, 669, 670, 671, 672, 673, 674, 675, 676, 677, 678, 679, 680, 681, 682, 683, 684, 685, 686, 687, 688, 689, 690, 691, 692, 693, 694, 695, 696, 697, 698, 699, 700, 701, 702, 703, 704, 705, 706, 707, 708, 709, 710, 711, 712, 713, 714, 715, 716, 717, 718, 719, 720, 721, 722, 723, 724, 725, 726, 727, 728, 729, 730, 731, 732, 733, 734, 735, 736, 737, 738, 739, 740, 741, 742, 743, 744, 745, 746, 747, 748, 749, 750, 751, 752, 753, 754, 755, 756, 757, 758, 759, 760, 761, 762, 763, 764, 765, 766, 767, 768, 769, 770, 771, 772, 773, 774, 775, 776, 777, 778, 779, 780, 781, 782, 783, 784, 785, 786, 787, 788, 789, 790, 791, 792, 793, 794, 795, 796, 797, 798, 799, 800, 801, 802, 803, 804, 805, 806, 807, 808, 809, 810, 811, 812, 813, 814, 815, 816, 817, 818, 819, 820, 821, 822, 823, 824, 825, 826, 827, 828, 829, 830, 831, 832, 833, 834, 835, 836, 837, 838, 839, 840, 841, 842, 843, 844, 845, 846, 847, 848, 849, 850, 851, 852, 853, 854, 855, 856, 857, 858, 859, 860, 861, 862, 863, 864, 865, 866, 867, 868, 869, 870, 871, 872, 873, 874, 875, 876, 877, 878, 879, 880, 881, 882, 883, 884, 885, 886, 887, 888, 889, 890, 891, 892, 893, 894, 895, 896, 897, 898, 899, 900, 901, 902, 903, 904, 905, 906, 907, 908, 909, 910, 911, 912, 913, 914, 915, 916, 917, 918, 919, 920, 921, 922, 923, 924, 925, 926, 927, 928, 929, 930, 931, 932, 933, 934, 935, 936, 937, 938, 939, 940, 941, 942, 943, 944, 945, 946, 947, 948, 949, 950, 951, 952, 953, 954, 955, 956, 957, 958, 959, 960, 961, 962, 963, 964, 965, 966, 967, 968, 969, 970, 971, 972, 973, 974, 975, 976, 977, 978, 979, 980, 981, 982, 983, 984, 985, 986, 987, 988, 989, 990, 991, 992, 993, 994, 995, 996, 997, 998, 999, 1000

MAIN CONTRACTOR :
Gammon

STRUCTURAL ENGINEER :
ARUP

FACADE CONSULTANT:
MEINHARDT

NOTE :
 1. ALL DIMENSIONS ARE IN mm.
 2. ALL ELEVATIONS ARE VIEWED FROM OUTSIDE.
 3. ALL DIMENSIONS TO BE VERIFIED ON SITE BEFORE FABRICATION.

LEGEND :
 X1 --- DETAIL MARK NO.
 X001 --- REFER SHEET NO.
 1. F.F.L. --- FINISHED FLOOR LEVEL
 2. S.F.L. --- STRUCTURAL FLOOR LEVEL
 3. (R) --- REVERSED DETAIL
 --- FIXING LOCATION
 --- FIXING LUG LOCATION
 GLASS LEGEND
 GL01 --- 8mm+12mm AIR GAP+10mm THK. I.G.U.
 GL01a --- 8mm+9mm AIR GAP+12mm THK. I.G.U.
 GL03 --- 6mm+12mm AIR GAP+6mm THK. I.G.U.
 GL04 --- 10mm THK. TEMPERED GLASS (PROTECTIVE BARRIER)
 GL05 --- 6mm+12mm AIR GAP+8mm THK. I.G.U.

NO.	DATE	REVISED	BY

JOB NO. : J-852
 PROJECT : PROPOSED RESIDENTIAL DEVELOPMENT
 AT 139 - 147 ARGYLE STREET,
 NKIL 6005, 6035 R.P., 6036 R.P.,
 6037 R.P. & 6038 R.P.

TITLE :
 DETAIL FOR
 Plenum Box

DATE : 05-Dec-19 SCALE : 1:2
 DRAWN BY : MN CHECKED BY : DW

美特鋁質有限公司
MIDI ALUMINIUM FABRICATOR LTD.
 Units 6-8, Sunray Industrial Centre, 1/F
 610 Cha Kwo Ling Road, Kowloon
 Tel:23489211-4 Fax:(852)2727666

DWG NO. : J852-SD-PB-5013 REV. : -

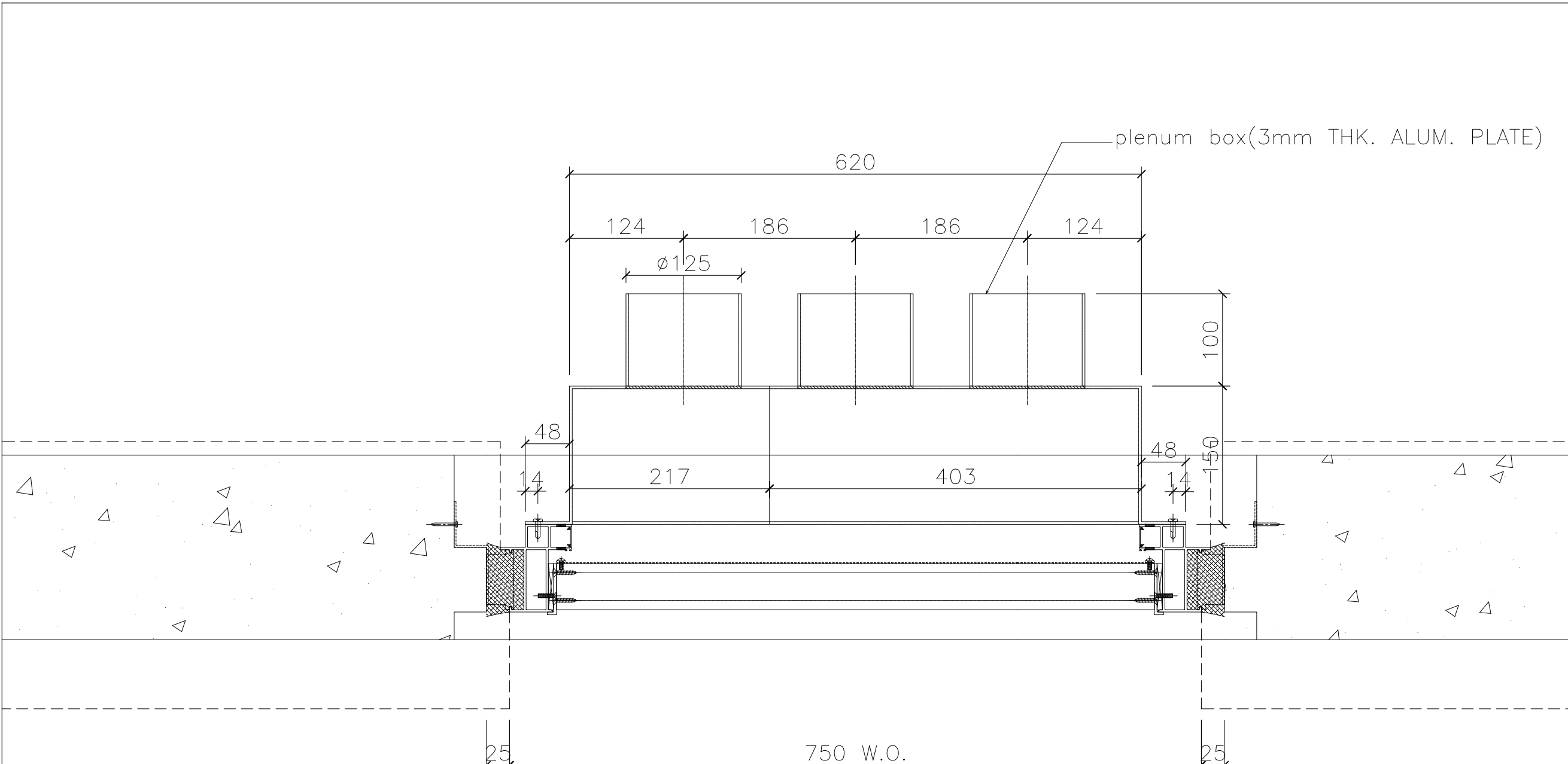

1 HORIZONTAL DETAIL OUTSIDE
SCALE 1:1

B.D. REF :

CLIENT :

ARCHITECT :
AGC DESIGN LTD
 110, 112, 114, 116, 118, 120, 122, 124, 126, 128, 130, 132, 134, 136, 138, 140, 142, 144, 146, 148, 150, 152, 154, 156, 158, 160, 162, 164, 166, 168, 170, 172, 174, 176, 178, 180, 182, 184, 186, 188, 190, 192, 194, 196, 198, 200, 202, 204, 206, 208, 210, 212, 214, 216, 218, 220, 222, 224, 226, 228, 230, 232, 234, 236, 238, 240, 242, 244, 246, 248, 250, 252, 254, 256, 258, 260, 262, 264, 266, 268, 270, 272, 274, 276, 278, 280, 282, 284, 286, 288, 290, 292, 294, 296, 298, 300, 302, 304, 306, 308, 310, 312, 314, 316, 318, 320, 322, 324, 326, 328, 330, 332, 334, 336, 338, 340, 342, 344, 346, 348, 350, 352, 354, 356, 358, 360, 362, 364, 366, 368, 370, 372, 374, 376, 378, 380, 382, 384, 386, 388, 390, 392, 394, 396, 398, 400, 402, 404, 406, 408, 410, 412, 414, 416, 418, 420, 422, 424, 426, 428, 430, 432, 434, 436, 438, 440, 442, 444, 446, 448, 450, 452, 454, 456, 458, 460, 462, 464, 466, 468, 470, 472, 474, 476, 478, 480, 482, 484, 486, 488, 490, 492, 494, 496, 498, 500, 502, 504, 506, 508, 510, 512, 514, 516, 518, 520, 522, 524, 526, 528, 530, 532, 534, 536, 538, 540, 542, 544, 546, 548, 550, 552, 554, 556, 558, 560, 562, 564, 566, 568, 570, 572, 574, 576, 578, 580, 582, 584, 586, 588, 590, 592, 594, 596, 598, 600, 602, 604, 606, 608, 610, 612, 614, 616, 618, 620, 622, 624, 626, 628, 630, 632, 634, 636, 638, 640, 642, 644, 646, 648, 650, 652, 654, 656, 658, 660, 662, 664, 666, 668, 670, 672, 674, 676, 678, 680, 682, 684, 686, 688, 690, 692, 694, 696, 698, 700, 702, 704, 706, 708, 710, 712, 714, 716, 718, 720, 722, 724, 726, 728, 730, 732, 734, 736, 738, 740, 742, 744, 746, 748, 750, 752, 754, 756, 758, 760, 762, 764, 766, 768, 770, 772, 774, 776, 778, 780, 782, 784, 786, 788, 790, 792, 794, 796, 798, 800, 802, 804, 806, 808, 810, 812, 814, 816, 818, 820, 822, 824, 826, 828, 830, 832, 834, 836, 838, 840, 842, 844, 846, 848, 850, 852, 854, 856, 858, 860, 862, 864, 866, 868, 870, 872, 874, 876, 878, 880, 882, 884, 886, 888, 890, 892, 894, 896, 898, 900, 902, 904, 906, 908, 910, 912, 914, 916, 918, 920, 922, 924, 926, 928, 930, 932, 934, 936, 938, 940, 942, 944, 946, 948, 950, 952, 954, 956, 958, 960, 962, 964, 966, 968, 970, 972, 974, 976, 978, 980, 982, 984, 986, 988, 990, 992, 994, 996, 998, 1000

MAIN CONTRACTOR :
Gammon

STRUCTURAL ENGINEER :
ARUP

FACADE CONSULTANT:
MEINHARDT

NOTE :
 1. ALL DIMENSIONS ARE IN mm.
 2. ALL ELEVATIONS ARE VIEWED FROM OUTSIDE.
 3. ALL DIMENSIONS TO BE VERIFIED ON SITE BEFORE FABRICATION.

LEGEND :
 x1 — DETAIL MARK NO.
 x001 — REFER SHEET NO.
 1. F.F.L. -- FINISHED FLOOR LEVEL
 2. S.F.L. -- STRUCTURAL FLOOR LEVEL
 3. (R) -- REVERSED DETAIL
 -- FIXING LOCATION
 -- FIXING LUG LOCATION

GLASS LEGEND
 GL01 -- 8mm+12mm AIR GAP+10mm THK. I.G.U.
 GL01a -- 8mm+9mm AIR GAP+12mm THK. I.G.U.
 GL03 -- 6mm+12mm AIR GAP+6mm THK. I.G.U.
 GL04 -- 10mm THK. TEMPERED GLASS (PROTECTIVE BARRIER)
 GL05 -- 6mm+12mm AIR GAP+8mm THK. I.G.U.

NO.	DATE	REVISED	BY

JOB NO. : J-852

PROJECT :
 PROPOSED RESIDENTIAL DEVELOPMENT
 AT 139 - 147 ARGYLE STREET,
 NKIL 6005, 6035 R.P., 6036 R.P.,
 6037 R.P. & 6038 R.P.

TITLE :
 DETAIL FOR
 Plenum Box

DATE : 05-Dec-19 SCALE : 1:2

DRAWN BY : MN CHECKED BY : DW

美特鋁質有限公司
MIDI ALUMINIUM FABRICATOR LTD.
 Units 6-8, Sunray Industrial Centre, 1/F
 610 Cha Kwo Ling Road, Kowloon
 Tel:23489211-4 Fax:(852)2727666

DWG NO. : J852-SD-PB-5014 REV. : -

OUTSIDE

200

W.O.

232

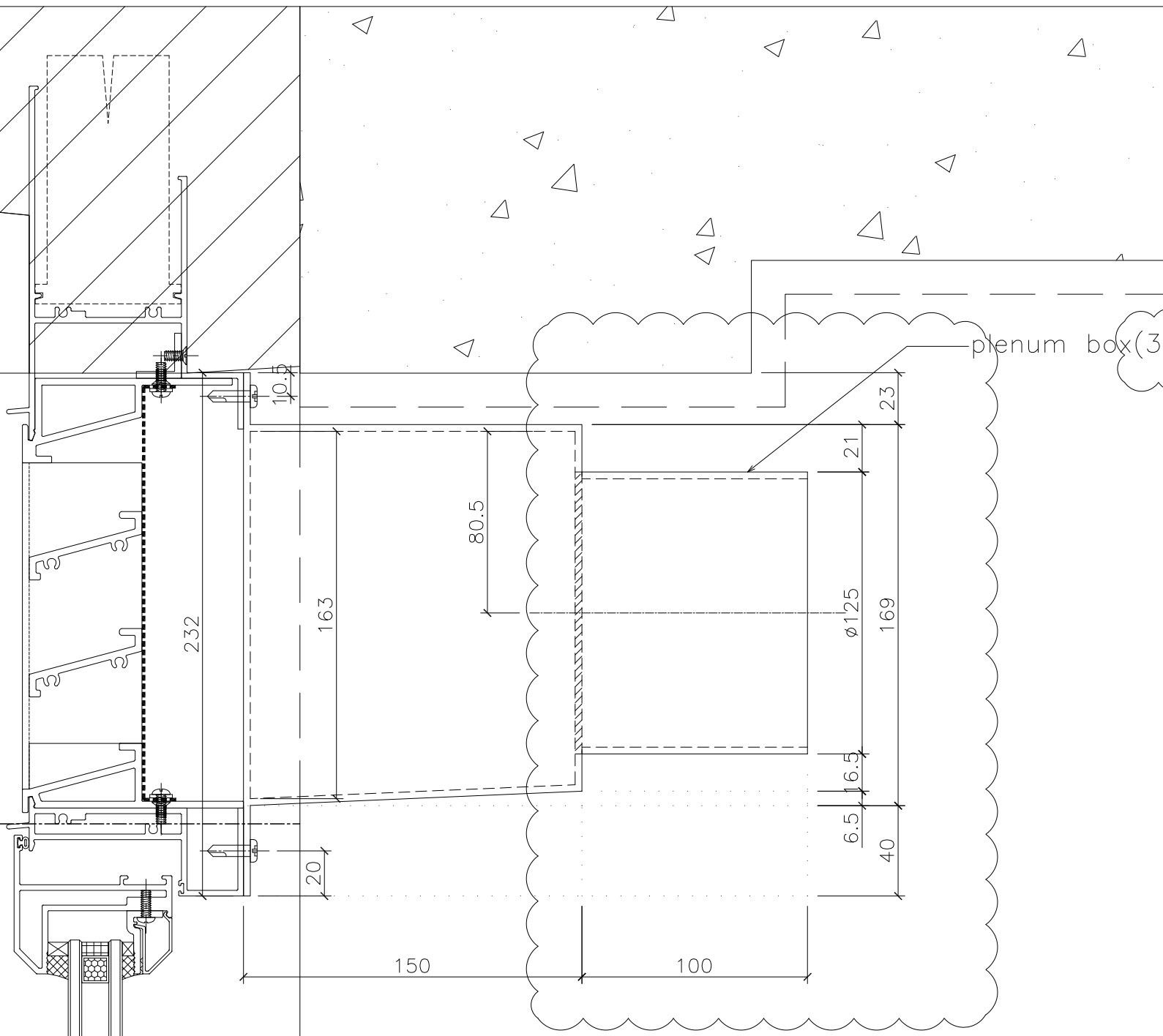

plenum box(3mm THK. ALUM. PLATE)

1 VERTICAL DETAIL
SCALE 1:1

B.D. REF :

CLIENT :

ARCHITECT :
AGC DESIGN LTD
AGC DESIGN LTD
161, 162, 163, 164, 165, 166, 167, 168, 169, 170, 171, 172, 173, 174, 175, 176, 177, 178, 179, 180, 181, 182, 183, 184, 185, 186, 187, 188, 189, 190, 191, 192, 193, 194, 195, 196, 197, 198, 199, 200, 201, 202, 203, 204, 205, 206, 207, 208, 209, 210, 211, 212, 213, 214, 215, 216, 217, 218, 219, 220, 221, 222, 223, 224, 225, 226, 227, 228, 229, 230, 231, 232, 233, 234, 235, 236, 237, 238, 239, 240, 241, 242, 243, 244, 245, 246, 247, 248, 249, 250, 251, 252, 253, 254, 255, 256, 257, 258, 259, 260, 261, 262, 263, 264, 265, 266, 267, 268, 269, 270, 271, 272, 273, 274, 275, 276, 277, 278, 279, 280, 281, 282, 283, 284, 285, 286, 287, 288, 289, 290, 291, 292, 293, 294, 295, 296, 297, 298, 299, 300, 301, 302, 303, 304, 305, 306, 307, 308, 309, 310, 311, 312, 313, 314, 315, 316, 317, 318, 319, 320, 321, 322, 323, 324, 325, 326, 327, 328, 329, 330, 331, 332, 333, 334, 335, 336, 337, 338, 339, 340, 341, 342, 343, 344, 345, 346, 347, 348, 349, 350, 351, 352, 353, 354, 355, 356, 357, 358, 359, 360, 361, 362, 363, 364, 365, 366, 367, 368, 369, 370, 371, 372, 373, 374, 375, 376, 377, 378, 379, 380, 381, 382, 383, 384, 385, 386, 387, 388, 389, 390, 391, 392, 393, 394, 395, 396, 397, 398, 399, 400, 401, 402, 403, 404, 405, 406, 407, 408, 409, 410, 411, 412, 413, 414, 415, 416, 417, 418, 419, 420, 421, 422, 423, 424, 425, 426, 427, 428, 429, 430, 431, 432, 433, 434, 435, 436, 437, 438, 439, 440, 441, 442, 443, 444, 445, 446, 447, 448, 449, 450, 451, 452, 453, 454, 455, 456, 457, 458, 459, 460, 461, 462, 463, 464, 465, 466, 467, 468, 469, 470, 471, 472, 473, 474, 475, 476, 477, 478, 479, 480, 481, 482, 483, 484, 485, 486, 487, 488, 489, 490, 491, 492, 493, 494, 495, 496, 497, 498, 499, 500, 501, 502, 503, 504, 505, 506, 507, 508, 509, 510, 511, 512, 513, 514, 515, 516, 517, 518, 519, 520, 521, 522, 523, 524, 525, 526, 527, 528, 529, 530, 531, 532, 533, 534, 535, 536, 537, 538, 539, 540, 541, 542, 543, 544, 545, 546, 547, 548, 549, 550, 551, 552, 553, 554, 555, 556, 557, 558, 559, 560, 561, 562, 563, 564, 565, 566, 567, 568, 569, 570, 571, 572, 573, 574, 575, 576, 577, 578, 579, 580, 581, 582, 583, 584, 585, 586, 587, 588, 589, 590, 591, 592, 593, 594, 595, 596, 597, 598, 599, 600, 601, 602, 603, 604, 605, 606, 607, 608, 609, 610, 611, 612, 613, 614, 615, 616, 617, 618, 619, 620, 621, 622, 623, 624, 625, 626, 627, 628, 629, 630, 631, 632, 633, 634, 635, 636, 637, 638, 639, 640, 641, 642, 643, 644, 645, 646, 647, 648, 649, 650, 651, 652, 653, 654, 655, 656, 657, 658, 659, 660, 661, 662, 663, 664, 665, 666, 667, 668, 669, 670, 671, 672, 673, 674, 675, 676, 677, 678, 679, 680, 681, 682, 683, 684, 685, 686, 687, 688, 689, 690, 691, 692, 693, 694, 695, 696, 697, 698, 699, 700, 701, 702, 703, 704, 705, 706, 707, 708, 709, 710, 711, 712, 713, 714, 715, 716, 717, 718, 719, 720, 721, 722, 723, 724, 725, 726, 727, 728, 729, 730, 731, 732, 733, 734, 735, 736, 737, 738, 739, 740, 741, 742, 743, 744, 745, 746, 747, 748, 749, 750, 751, 752, 753, 754, 755, 756, 757, 758, 759, 760, 761, 762, 763, 764, 765, 766, 767, 768, 769, 770, 771, 772, 773, 774, 775, 776, 777, 778, 779, 780, 781, 782, 783, 784, 785, 786, 787, 788, 789, 790, 791, 792, 793, 794, 795, 796, 797, 798, 799, 800, 801, 802, 803, 804, 805, 806, 807, 808, 809, 810, 811, 812, 813, 814, 815, 816, 817, 818, 819, 820, 821, 822, 823, 824, 825, 826, 827, 828, 829, 830, 831, 832, 833, 834, 835, 836, 837, 838, 839, 840, 841, 842, 843, 844, 845, 846, 847, 848, 849, 850, 851, 852, 853, 854, 855, 856, 857, 858, 859, 860, 861, 862, 863, 864, 865, 866, 867, 868, 869, 870, 871, 872, 873, 874, 875, 876, 877, 878, 879, 880, 881, 882, 883, 884, 885, 886, 887, 888, 889, 890, 891, 892, 893, 894, 895, 896, 897, 898, 899, 900, 901, 902, 903, 904, 905, 906, 907, 908, 909, 910, 911, 912, 913, 914, 915, 916, 917, 918, 919, 920, 921, 922, 923, 924, 925, 926, 927, 928, 929, 930, 931, 932, 933, 934, 935, 936, 937, 938, 939, 940, 941, 942, 943, 944, 945, 946, 947, 948, 949, 950, 951, 952, 953, 954, 955, 956, 957, 958, 959, 960, 961, 962, 963, 964, 965, 966, 967, 968, 969, 970, 971, 972, 973, 974, 975, 976, 977, 978, 979, 980, 981, 982, 983, 984, 985, 986, 987, 988, 989, 990, 991, 992, 993, 994, 995, 996, 997, 998, 999, 1000

MAIN CONTRACTOR :
Gammon

STRUCTURAL ENGINEER :
ARUP

FACADE CONSULTANT:
MEINHARDT

NOTE :

1. ALL DIMENSIONS ARE IN mm.
2. ALL ELEVATIONS ARE VIEWED FROM OUTSIDE.
3. ALL DIMENSIONS TO BE VERIFIED ON SITE BEFORE FABRICATION.

LEGEND :

x1 — DETAIL MARK NO.
x001 — REFER SHEET NO.

1. F.F.L. -- FINISHED FLOOR LEVEL
2. S.F.L. -- STRUCTURAL FLOOR LEVEL
3. (R) -- REVERSED DETAIL
4. ▲ -- FIXING LOCATION
5. △ -- FIXING LUG LOCATION
6. GLASS LEGEND
GL01 -- 8mm+12mm AIR GAP+10mm THK. I.G.U.
GL01a -- 8mm+9mm AIR GAP+12mm THK. I.G.U.
GL02 -- 10mm THK. TEMPERED GLASS (SPANDREL GLASS)
GL03 -- 6mm+12mm AIR GAP+6mm THK. I.G.U.
GL04 -- 10mm THK. TEMPERED GLASS (PROTECTIVE BARRIER)
GL05 -- 6mm+12mm AIR GAP+8mm THK. I.G.U.

NO.	DATE	REVISION	BY
A	07/11/2020	REVISION SUBJECT TO ARCH.COMMENT	lvn

JOB NO. : J-852

PROJECT :
PROPOSED RESIDENTIAL DEVELOPMENT
AT 139 - 147 ARGYLE STREET,
NKIL 6005, 6035 R.P., 6036 R.P.,
6037 R.P. & 6038 R.P.

TITLE :
DETAIL FOR
Plenum Box

DATE : 05-Dec-19 SCALE : 1:2

DRAWN BY : MN CHECKED BY : DW

美特鋁質有限公司
MIDI ALUMINIUM FABRICATOR LTD.
Units 6-8, Sunray Industrial Centre, 1/F
610 Cha Kwo Ling Road, Kowloon
Tel:23489211-4 Fax:(852)2727666

DWG NO. : J852-SD-PB-6001 REV. : A

OUTSIDE

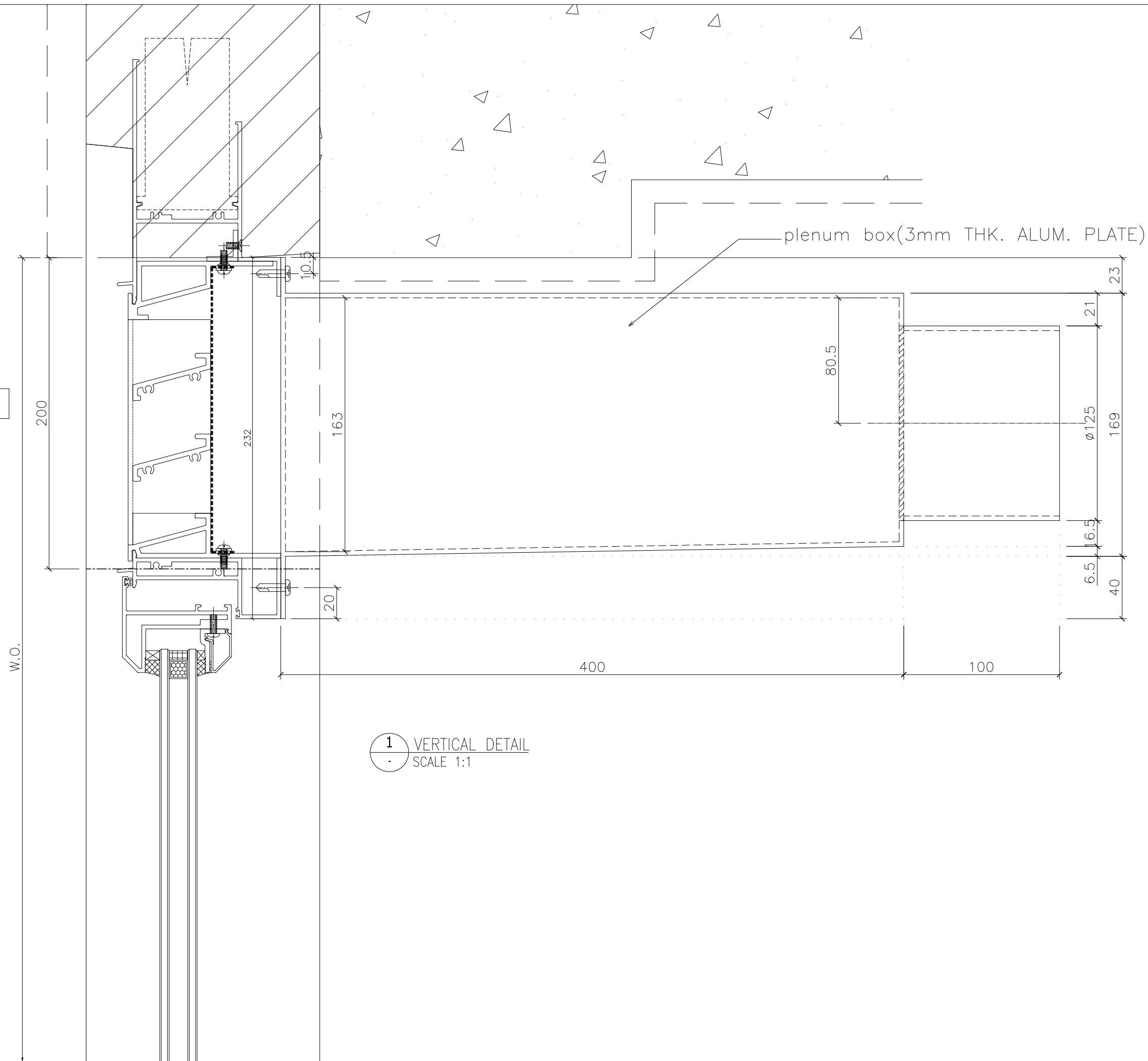

1 VERTICAL DETAIL
SCALE 1:1

B.D. REF :

CLIENT :

ARCHITECT :
AGC DESIGN LTD
 10/F, 100, Queen Mary Road, 200, King's Road, North Point, Hong Kong
 Tel: (852) 2511 1111 Fax: (852) 2511 1112 Email: agc@agc.com.hk

MAIN CONTRACTOR :
Gammon

STRUCTURAL ENGINEER :
ARUP

FAÇADE CONSULTANT:
MEINHARDT

NOTE :
 1. ALL DIMENSIONS ARE IN mm.
 2. ALL ELEVATIONS ARE VIEWED FROM OUTSIDE.
 3. ALL DIMENSIONS TO BE VERIFIED ON SITE BEFORE FABRICATION.

LEGEND :

x1 — DETAIL MARK NO.
 x001 — REFER SHEET NO.

1. F.F.L. -- FINISHED FLOOR LEVEL
 2. S.F.L. -- STRUCTURAL FLOOR LEVEL
 3. (R) -- REVERSED DETAIL
 4. ▲ -- FIXING LOCATION
 5. △ -- FIXING LUG LOCATION
 6. GLASS LEGEND
 GL01 -- 8mm+12mm AIR GAP+10mm THK. I.G.U.
 GL01a -- 8mm+9mm AIR GAP+12mm THK. I.G.U.
 GL02 -- 10mm THK. TEMPERED GLASS (SPANDREL GLASS)
 GL03 -- 6mm+12mm AIR GAP+6mm THK. I.G.U.
 GL04 -- 10mm THK. TEMPERED GLASS (PROTECTIVE BARRIER)
 GL05 -- 6mm+12mm AIR GAP+8mm THK. I.G.U.

NO.	DATE	REVISED	BY
-----	------	---------	----

JOB NO. : J-852
 PROJECT : PROPOSED RESIDENTIAL DEVELOPMENT
 AT 139 - 147 ARGYLE STREET,
 NKIL 6005, 6035 R.P., 6036 R.P.,
 6037 R.P. & 6038 R.P.

TITLE :
 DETAIL FOR
 Plenum Box

DATE : 05-Dec-19 SCALE : 1:2

DRAWN BY : MN CHECKED BY : DW

美特鋁質有限公司
MIDI ALUMINIUM FABRICATOR LTD.
 Units 6-8, Sunray Industrial Centre, 1/F
 610 Cha Kwo Ling Road, Kowloon
 Tel:23489211-4 Fax:(852)2727666

DWG NO. : J852-SD-PB-6001a REV. : -

OUTSIDE

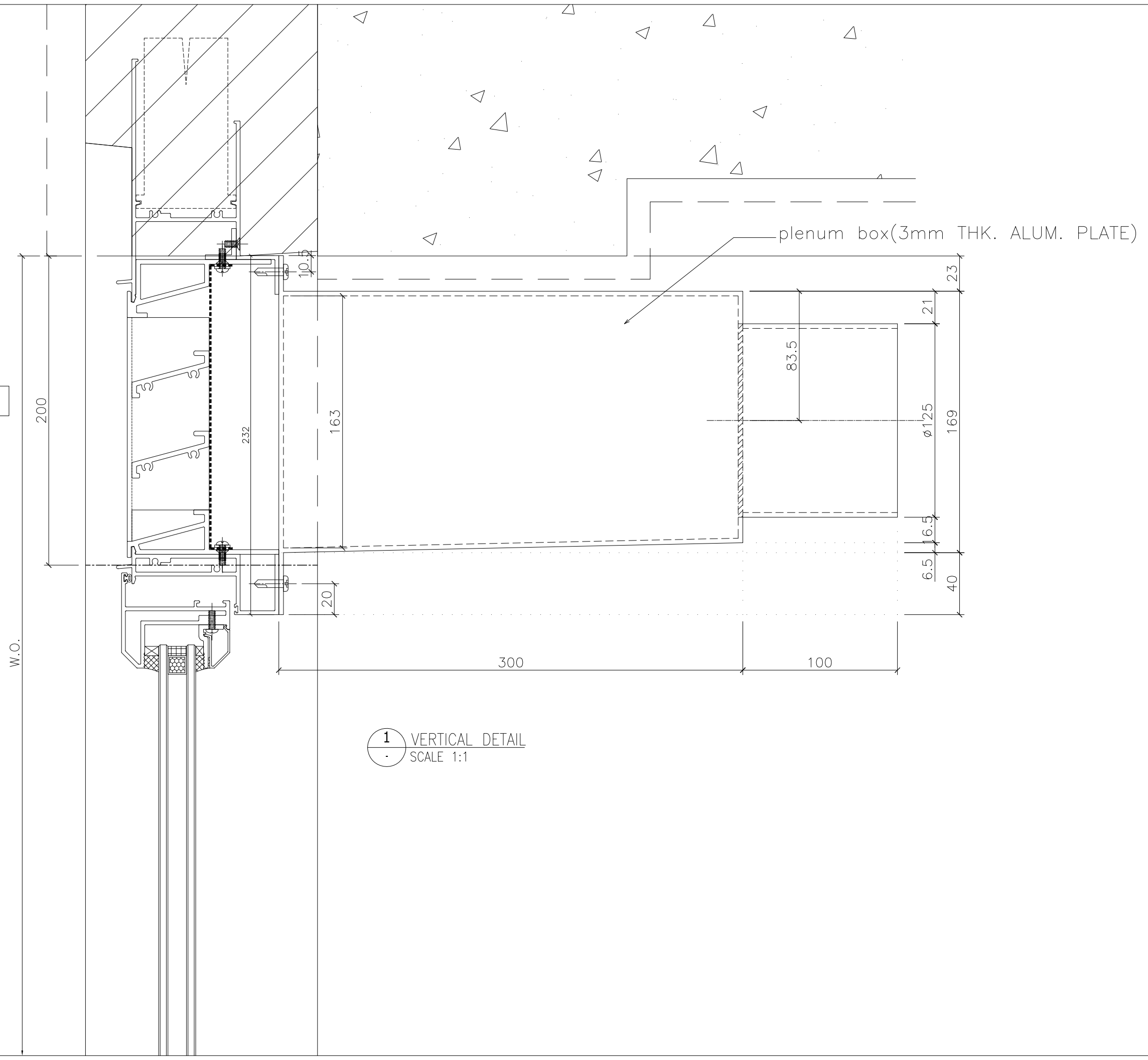

1 VERTICAL DETAIL
SCALE 1:1

B.D. REF :

CLIENT :

ARCHITECT :

AGC DESIGN LTD
 181, 182, 183, 184, 185, 186, 187, 188, 189, 190, 191, 192, 193, 194, 195, 196, 197, 198, 199, 200, 201, 202, 203, 204, 205, 206, 207, 208, 209, 210, 211, 212, 213, 214, 215, 216, 217, 218, 219, 220, 221, 222, 223, 224, 225, 226, 227, 228, 229, 230, 231, 232, 233, 234, 235, 236, 237, 238, 239, 240, 241, 242, 243, 244, 245, 246, 247, 248, 249, 250, 251, 252, 253, 254, 255, 256, 257, 258, 259, 260, 261, 262, 263, 264, 265, 266, 267, 268, 269, 270, 271, 272, 273, 274, 275, 276, 277, 278, 279, 280, 281, 282, 283, 284, 285, 286, 287, 288, 289, 290, 291, 292, 293, 294, 295, 296, 297, 298, 299, 300, 301, 302, 303, 304, 305, 306, 307, 308, 309, 310, 311, 312, 313, 314, 315, 316, 317, 318, 319, 320, 321, 322, 323, 324, 325, 326, 327, 328, 329, 330, 331, 332, 333, 334, 335, 336, 337, 338, 339, 340, 341, 342, 343, 344, 345, 346, 347, 348, 349, 350, 351, 352, 353, 354, 355, 356, 357, 358, 359, 360, 361, 362, 363, 364, 365, 366, 367, 368, 369, 370, 371, 372, 373, 374, 375, 376, 377, 378, 379, 380, 381, 382, 383, 384, 385, 386, 387, 388, 389, 390, 391, 392, 393, 394, 395, 396, 397, 398, 399, 400, 401, 402, 403, 404, 405, 406, 407, 408, 409, 410, 411, 412, 413, 414, 415, 416, 417, 418, 419, 420, 421, 422, 423, 424, 425, 426, 427, 428, 429, 430, 431, 432, 433, 434, 435, 436, 437, 438, 439, 440, 441, 442, 443, 444, 445, 446, 447, 448, 449, 450, 451, 452, 453, 454, 455, 456, 457, 458, 459, 460, 461, 462, 463, 464, 465, 466, 467, 468, 469, 470, 471, 472, 473, 474, 475, 476, 477, 478, 479, 480, 481, 482, 483, 484, 485, 486, 487, 488, 489, 490, 491, 492, 493, 494, 495, 496, 497, 498, 499, 500

MAIN CONTRACTOR :

Gammon

STRUCTURAL ENGINEER :

ARUP

FAÇADE CONSULTANT:

MEINHARDT

NOTE :

- ALL DIMENSIONS ARE IN mm.
- ALL ELEVATIONS ARE VIEWED FROM OUTSIDE.
- ALL DIMENSIONS TO BE VERIFIED ON SITE BEFORE FABRICATION.

LEGEND :

x1 --- DETAIL MARK NO.
 x001 --- REFER SHEET NO.

- F.F.L. -- FINISHED FLOOR LEVEL
- S.F.L. -- STRUCTURAL FLOOR LEVEL
- ⊗ -- REVERSED DETAIL
- ▲ -- FIXING LOCATION
- △ -- FIXING LUG LOCATION
- GLASS LEGEND

GL01 -- 8mm+12mm AIR GAP+10mm THK. I.G.U.
 GL01a -- 8mm+9mm AIR GAP+12mm THK. I.G.U.
 GL02 -- 10mm THK. TEMPERED GLASS (SPANDREL GLASS)
 GL03 -- 6mm+12mm AIR GAP+6mm THK. I.G.U.
 GL04 -- 10mm THK. TEMPERED GLASS (PROTECTIVE BARRIER)
 GL05 -- 6mm+12mm AIR GAP+8mm THK. I.G.U.

NO.	DATE	REVISED	BY
JOB NO. : J-852			
PROJECT : PROPOSED RESIDENTIAL DEVELOPMENT AT 139 - 147 ARGYLE STREET, NKIL 6005, 6035 R.P., 6036 R.P., 6037 R.P. & 6038 R.P.			
TITLE : DETAIL FOR Plenum Box			
DATE : 05-Dec-19		SCALE : 1:2	
DRAWN BY : MN		CHECKED BY : DW	
<p>美特鋁質有限公司 MIDI ALUMINIUM FABRICATOR LTD. Units 6-8, Sunray Industrial Centre, 1/F 610 Cha Kwo Ling Road, Kowloon Tel:23489211-4 Fax:(852)2727666</p>			
DWG NO. : J852-SD-PB-6001b			REV. : -

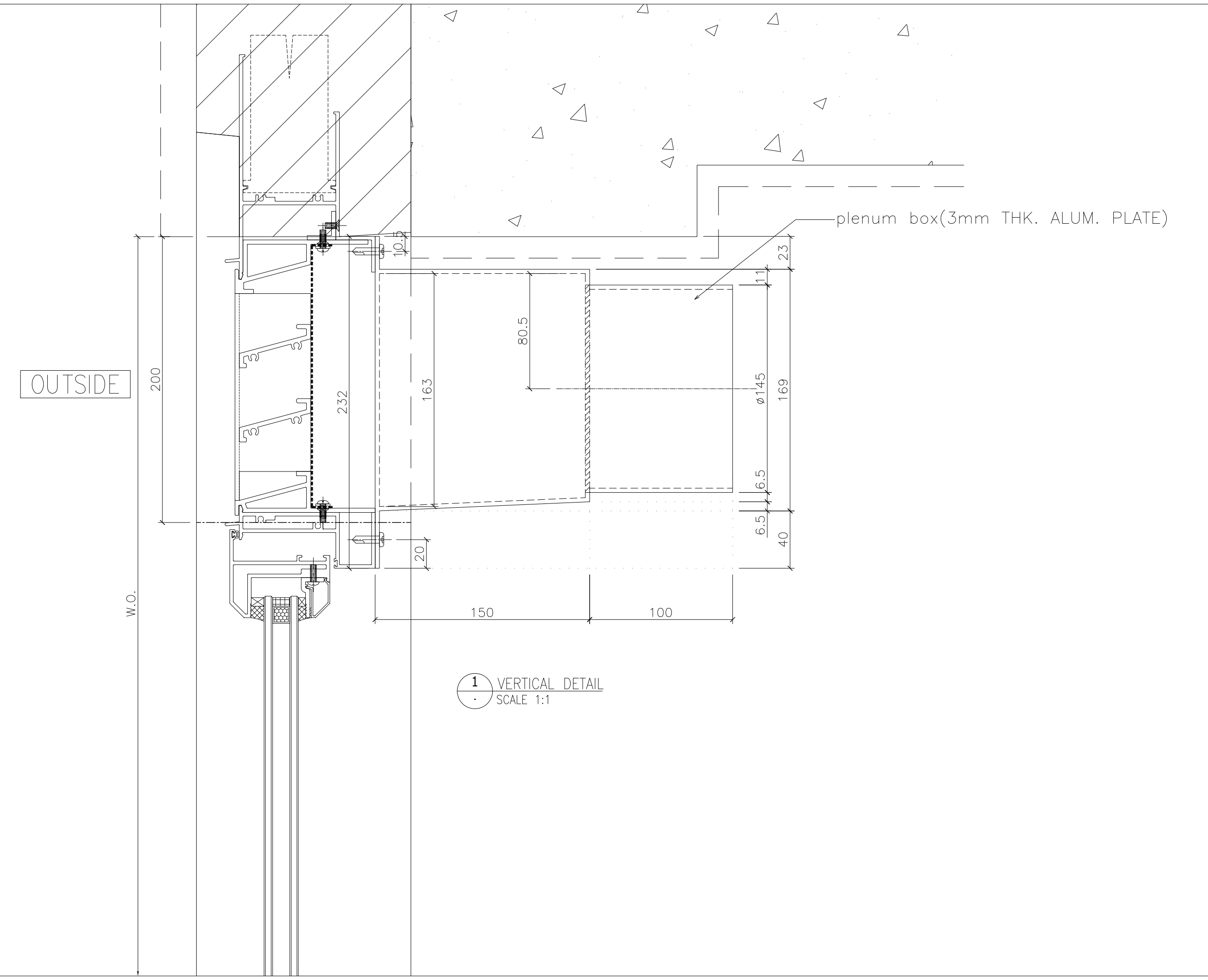

B.D. REF :

CLIENT :

ARCHITECT :
AGC DESIGN LTD
 181, 182, 183, 184, 185, 186, 187, 188, 189, 190, 191, 192, 193, 194, 195, 196, 197, 198, 199, 200, 201, 202, 203, 204, 205, 206, 207, 208, 209, 210, 211, 212, 213, 214, 215, 216, 217, 218, 219, 220, 221, 222, 223, 224, 225, 226, 227, 228, 229, 230, 231, 232, 233, 234, 235, 236, 237, 238, 239, 240, 241, 242, 243, 244, 245, 246, 247, 248, 249, 250, 251, 252, 253, 254, 255, 256, 257, 258, 259, 260, 261, 262, 263, 264, 265, 266, 267, 268, 269, 270, 271, 272, 273, 274, 275, 276, 277, 278, 279, 280, 281, 282, 283, 284, 285, 286, 287, 288, 289, 290, 291, 292, 293, 294, 295, 296, 297, 298, 299, 300, 301, 302, 303, 304, 305, 306, 307, 308, 309, 310, 311, 312, 313, 314, 315, 316, 317, 318, 319, 320, 321, 322, 323, 324, 325, 326, 327, 328, 329, 330, 331, 332, 333, 334, 335, 336, 337, 338, 339, 340, 341, 342, 343, 344, 345, 346, 347, 348, 349, 350, 351, 352, 353, 354, 355, 356, 357, 358, 359, 360, 361, 362, 363, 364, 365, 366, 367, 368, 369, 370, 371, 372, 373, 374, 375, 376, 377, 378, 379, 380, 381, 382, 383, 384, 385, 386, 387, 388, 389, 390, 391, 392, 393, 394, 395, 396, 397, 398, 399, 400, 401, 402, 403, 404, 405, 406, 407, 408, 409, 410, 411, 412, 413, 414, 415, 416, 417, 418, 419, 420, 421, 422, 423, 424, 425, 426, 427, 428, 429, 430, 431, 432, 433, 434, 435, 436, 437, 438, 439, 440, 441, 442, 443, 444, 445, 446, 447, 448, 449, 450, 451, 452, 453, 454, 455, 456, 457, 458, 459, 460, 461, 462, 463, 464, 465, 466, 467, 468, 469, 470, 471, 472, 473, 474, 475, 476, 477, 478, 479, 480, 481, 482, 483, 484, 485, 486, 487, 488, 489, 490, 491, 492, 493, 494, 495, 496, 497, 498, 499, 500, 501, 502, 503, 504, 505, 506, 507, 508, 509, 510, 511, 512, 513, 514, 515, 516, 517, 518, 519, 520, 521, 522, 523, 524, 525, 526, 527, 528, 529, 530, 531, 532, 533, 534, 535, 536, 537, 538, 539, 540, 541, 542, 543, 544, 545, 546, 547, 548, 549, 550, 551, 552, 553, 554, 555, 556, 557, 558, 559, 560, 561, 562, 563, 564, 565, 566, 567, 568, 569, 570, 571, 572, 573, 574, 575, 576, 577, 578, 579, 580, 581, 582, 583, 584, 585, 586, 587, 588, 589, 590, 591, 592, 593, 594, 595, 596, 597, 598, 599, 600, 601, 602, 603, 604, 605, 606, 607, 608, 609, 610, 611, 612, 613, 614, 615, 616, 617, 618, 619, 620, 621, 622, 623, 624, 625, 626, 627, 628, 629, 630, 631, 632, 633, 634, 635, 636, 637, 638, 639, 640, 641, 642, 643, 644, 645, 646, 647, 648, 649, 650, 651, 652, 653, 654, 655, 656, 657, 658, 659, 660, 661, 662, 663, 664, 665, 666, 667, 668, 669, 670, 671, 672, 673, 674, 675, 676, 677, 678, 679, 680, 681, 682, 683, 684, 685, 686, 687, 688, 689, 690, 691, 692, 693, 694, 695, 696, 697, 698, 699, 700, 701, 702, 703, 704, 705, 706, 707, 708, 709, 710, 711, 712, 713, 714, 715, 716, 717, 718, 719, 720, 721, 722, 723, 724, 725, 726, 727, 728, 729, 730, 731, 732, 733, 734, 735, 736, 737, 738, 739, 740, 741, 742, 743, 744, 745, 746, 747, 748, 749, 750, 751, 752, 753, 754, 755, 756, 757, 758, 759, 760, 761, 762, 763, 764, 765, 766, 767, 768, 769, 770, 771, 772, 773, 774, 775, 776, 777, 778, 779, 780, 781, 782, 783, 784, 785, 786, 787, 788, 789, 790, 791, 792, 793, 794, 795, 796, 797, 798, 799, 800, 801, 802, 803, 804, 805, 806, 807, 808, 809, 810, 811, 812, 813, 814, 815, 816, 817, 818, 819, 820, 821, 822, 823, 824, 825, 826, 827, 828, 829, 830, 831, 832, 833, 834, 835, 836, 837, 838, 839, 840, 841, 842, 843, 844, 845, 846, 847, 848, 849, 850, 851, 852, 853, 854, 855, 856, 857, 858, 859, 860, 861, 862, 863, 864, 865, 866, 867, 868, 869, 870, 871, 872, 873, 874, 875, 876, 877, 878, 879, 880, 881, 882, 883, 884, 885, 886, 887, 888, 889, 890, 891, 892, 893, 894, 895, 896, 897, 898, 899, 900, 901, 902, 903, 904, 905, 906, 907, 908, 909, 910, 911, 912, 913, 914, 915, 916, 917, 918, 919, 920, 921, 922, 923, 924, 925, 926, 927, 928, 929, 930, 931, 932, 933, 934, 935, 936, 937, 938, 939, 940, 941, 942, 943, 944, 945, 946, 947, 948, 949, 950, 951, 952, 953, 954, 955, 956, 957, 958, 959, 960, 961, 962, 963, 964, 965, 966, 967, 968, 969, 970, 971, 972, 973, 974, 975, 976, 977, 978, 979, 980, 981, 982, 983, 984, 985, 986, 987, 988, 989, 990, 991, 992, 993, 994, 995, 996, 997, 998, 999, 1000

MAIN CONTRACTOR :
Gammon

STRUCTURAL ENGINEER :
ARUP

FACADE CONSULTANT:
MEINHARDT

NOTE :
 1. ALL DIMENSIONS ARE IN mm.
 2. ALL ELEVATIONS ARE VIEWED FROM OUTSIDE.
 3. ALL DIMENSIONS TO BE VERIFIED ON SITE BEFORE FABRICATION.

LEGEND :
 (x1) --- DETAIL MARK NO.
 (x001) --- REFER SHEET NO.
 1. F.F.L. --- FINISHED FLOOR LEVEL
 2. S.F.L. --- STRUCTURAL FLOOR LEVEL
 3. (R) --- REVERSED DETAIL
 4. ▲ --- FIXING LOCATION
 5. △ --- FIXING LUG LOCATION
 6. GLASS LEGEND
 GL01 --- 8mm+12mm AIR GAP+10mm THK. I.G.U.
 GL01a --- 8mm+9mm AIR GAP+12mm THK. I.G.U.
 GL02 --- 10mm THK. TEMPERED GLASS (SPANDREL GLASS)
 GL03 --- 6mm+12mm AIR GAP+6mm THK. I.G.U.
 GL04 --- 10mm THK. TEMPERED GLASS (PROTECTIVE BARRIER)
 GL05 --- 6mm+12mm AIR GAP+8mm THK. I.G.U.

NO.	DATE	REVISED	BY
-----	------	---------	----

JOB NO. : J-852
 PROJECT : PROPOSED RESIDENTIAL DEVELOPMENT
 AT 139 - 147 ARGYLE STREET,
 NKIL 6005, 6035 R.P., 6036 R.P.,
 6037 R.P. & 6038 R.P.

TITLE :
 DETAIL FOR
 Plenum Box

DATE : 05-Dec-19 SCALE : 1:2
 DRAWN BY : MN CHECKED BY : DW

美特鋁質有限公司
MIDI ALUMINIUM FABRICATOR LTD.
 Units 6-8, Sunray Industrial Centre, 1/F
 610 Cha Kwo Ling Road, Kowloon
 Tel:23489211-4 Fax:(852)2727666

DWG NO. : J852-SD-PB-6001c REV. : -

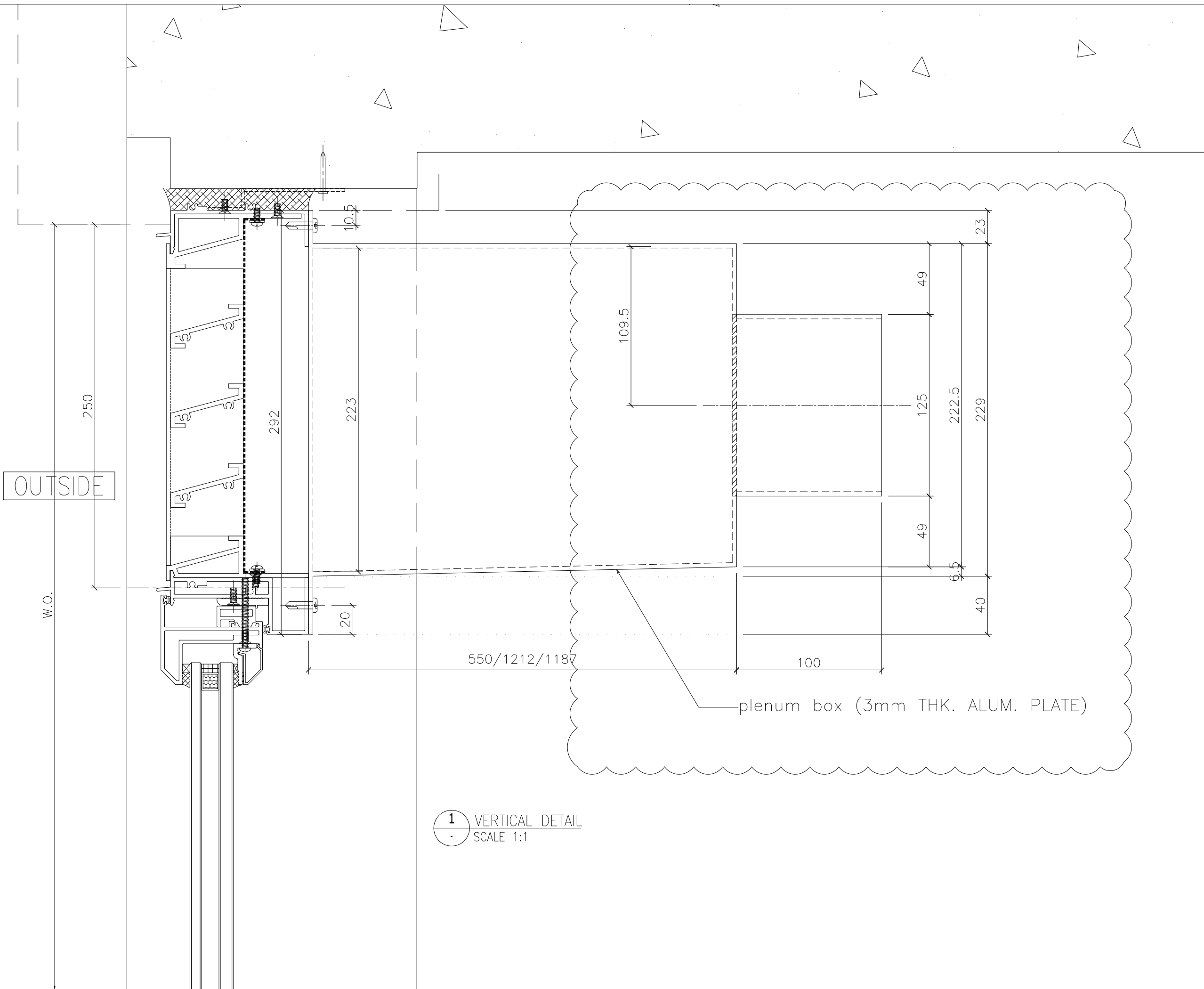

1 VERTICAL DETAIL
SCALE 1:1

B.D. REF :

CLIENT :

ARCHITECT :
AGC DESIGN LTD
 10/F, 107, Spadina Road, 221, Hong Kong
 Tel: (852) 2521 1111, Fax: (852) 2521 1112, Email: agc@agc.com.hk

MAIN CONTRACTOR :
Gammon

STRUCTURAL ENGINEER :
ARUP

FACADE CONSULTANT:
MEINHARDT

NOTE :

1. ALL DIMENSIONS ARE IN mm.
2. ALL ELEVATIONS ARE VIEWED FROM OUTSIDE.
3. ALL DIMENSIONS TO BE VERIFIED ON SITE BEFORE FABRICATION.

LEGEND :

(x1) — DETAIL MARK NO.
 (x001) — REFER SHEET NO.

1. F.F.L. -- FINISHED FLOOR LEVEL
2. S.F.L. -- STRUCTURAL FLOOR LEVEL
3. (R) -- REVERSED DETAIL
4. ▲ -- FIXING LOCATION
5. △ -- FIXING LUG LOCATION
6. GLASS LEGEND
 GL01 -- 8mm+12mm AIR GAP+10mm THK. I.G.U.
 GL01a -- 8mm+9mm AIR GAP+12mm THK. I.G.U.
 GL02 -- 10mm THK. TEMPERED GLASS (SPANDREL GLASS)
 GL03 -- 6mm+12mm AIR GAP+6mm THK. I.G.U.
 GL04 -- 10mm THK. TEMPERED GLASS (PROTECTIVE BARRIER)
 GL05 -- 6mm+12mm AIR GAP+8mm THK. I.G.U.

NO.	DATE	REVISION	BY
A	07/11/2020	REVISION SUBJECT TO ARCH.COMMENT	lvn

JOB NO. : J-852

PROJECT :
 PROPOSED RESIDENTIAL DEVELOPMENT
 AT 139 - 147 ARGYLE STREET,
 NKIL 6005, 6035 R.P., 6036 R.P.,
 6037 R.P. & 6038 R.P.

TITLE :
 DETAIL FOR
 Plenum Box

DATE : 05-Dec-19 SCALE : 1:2

DRAWN BY : MN CHECKED BY : DW

美特鋁質有限公司
MIDI ALUMINIUM FABRICATOR LTD.
 Units 6-8, Sunray Industrial Centre, 1/F
 610 Cha Kwo Ling Road, Kowloon
 Tel:23489211-4 Fax:(852)2727666

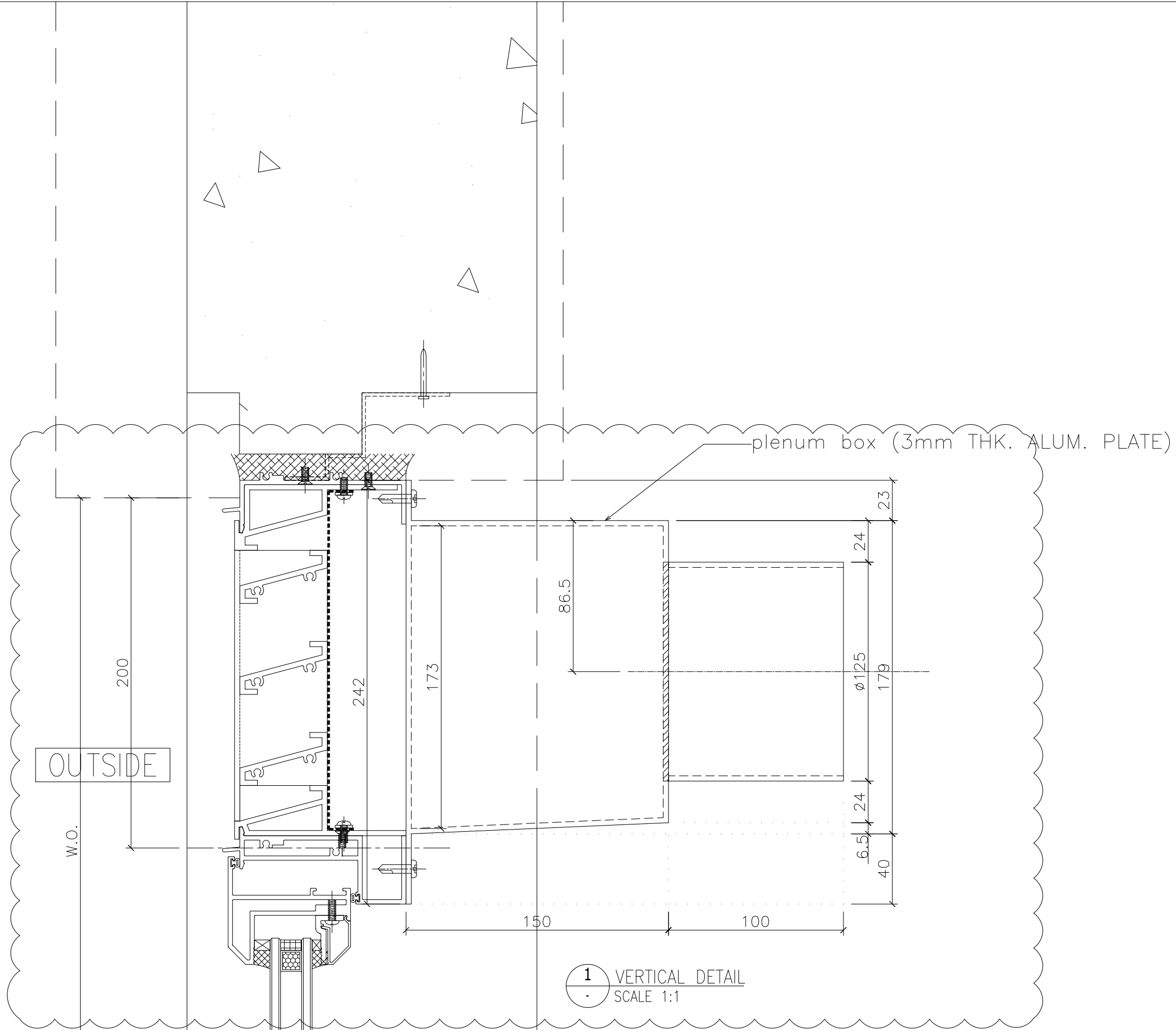

1 VERTICAL DETAIL
SCALE 1:1

B.D. REF :

CLIENT :

ARCHITECT :
AGC DESIGN LTD
181, 183, 185, 187, 189, 191, 193, 195, 197, 199, 201, 203, 205, 207, 209, 211, 213, 215, 217, 219, 221, 223, 225, 227, 229, 231, 233, 235, 237, 239, 241, 243, 245, 247, 249, 251, 253, 255, 257, 259, 261, 263, 265, 267, 269, 271, 273, 275, 277, 279, 281, 283, 285, 287, 289, 291, 293, 295, 297, 299, 301, 303, 305, 307, 309, 311, 313, 315, 317, 319, 321, 323, 325, 327, 329, 331, 333, 335, 337, 339, 341, 343, 345, 347, 349, 351, 353, 355, 357, 359, 361, 363, 365, 367, 369, 371, 373, 375, 377, 379, 381, 383, 385, 387, 389, 391, 393, 395, 397, 399, 401, 403, 405, 407, 409, 411, 413, 415, 417, 419, 421, 423, 425, 427, 429, 431, 433, 435, 437, 439, 441, 443, 445, 447, 449, 451, 453, 455, 457, 459, 461, 463, 465, 467, 469, 471, 473, 475, 477, 479, 481, 483, 485, 487, 489, 491, 493, 495, 497, 499, 501, 503, 505, 507, 509, 511, 513, 515, 517, 519, 521, 523, 525, 527, 529, 531, 533, 535, 537, 539, 541, 543, 545, 547, 549, 551, 553, 555, 557, 559, 561, 563, 565, 567, 569, 571, 573, 575, 577, 579, 581, 583, 585, 587, 589, 591, 593, 595, 597, 599, 601, 603, 605, 607, 609, 611, 613, 615, 617, 619, 621, 623, 625, 627, 629, 631, 633, 635, 637, 639, 641, 643, 645, 647, 649, 651, 653, 655, 657, 659, 661, 663, 665, 667, 669, 671, 673, 675, 677, 679, 681, 683, 685, 687, 689, 691, 693, 695, 697, 699, 701, 703, 705, 707, 709, 711, 713, 715, 717, 719, 721, 723, 725, 727, 729, 731, 733, 735, 737, 739, 741, 743, 745, 747, 749, 751, 753, 755, 757, 759, 761, 763, 765, 767, 769, 771, 773, 775, 777, 779, 781, 783, 785, 787, 789, 791, 793, 795, 797, 799, 801, 803, 805, 807, 809, 811, 813, 815, 817, 819, 821, 823, 825, 827, 829, 831, 833, 835, 837, 839, 841, 843, 845, 847, 849, 851, 853, 855, 857, 859, 861, 863, 865, 867, 869, 871, 873, 875, 877, 879, 881, 883, 885, 887, 889, 891, 893, 895, 897, 899, 901, 903, 905, 907, 909, 911, 913, 915, 917, 919, 921, 923, 925, 927, 929, 931, 933, 935, 937, 939, 941, 943, 945, 947, 949, 951, 953, 955, 957, 959, 961, 963, 965, 967, 969, 971, 973, 975, 977, 979, 981, 983, 985, 987, 989, 991, 993, 995, 997, 999

MAIN CONTRACTOR :
Gammon

STRUCTURAL ENGINEER :
ARUP

FACADE CONSULTANT:
MEINHARDT

NOTE :
1. ALL DIMENSIONS ARE IN mm.
2. ALL ELEVATIONS ARE VIEWED FROM OUTSIDE.
3. ALL DIMENSIONS TO BE VERIFIED ON SITE BEFORE FABRICATION.

LEGEND :
x1 — DETAIL MARK NO.
x001 — REFER SHEET NO.
1. F.F.L. -- FINISHED FLOOR LEVEL
2. S.F.L. -- STRUCTURAL FLOOR LEVEL
3. (R) -- REVERSED DETAIL

NO.	DATE	REVISION	BY
A	09/12/2020	REVISION SUBJECT TO ARCH.COMMENT	Ivan

JOB NO. : J-852
PROJECT : PROPOSED RESIDENTIAL DEVELOPMENT AT 139 - 147 ARGYLE STREET, NKIL 6005, 6035 R.P., 6036 R.P., 6037 R.P. & 6038 R.P.

TITLE : DETAIL FOR Plenum Box

DATE : 05-Dec-19 SCALE : 1:2
DRAWN BY : MN CHECKED BY : DW

美特鋁質有限公司
MIDI ALUMINIUM FABRICATOR LTD.
Units 6-8, Sunray Industrial Centre, 1/F
610 Cha Kwo Ling Road, Kowloon
Tel:23489211-4 Fax:(852)2727666

DWG NO. : J852-SD-PB-6003 REV. : A

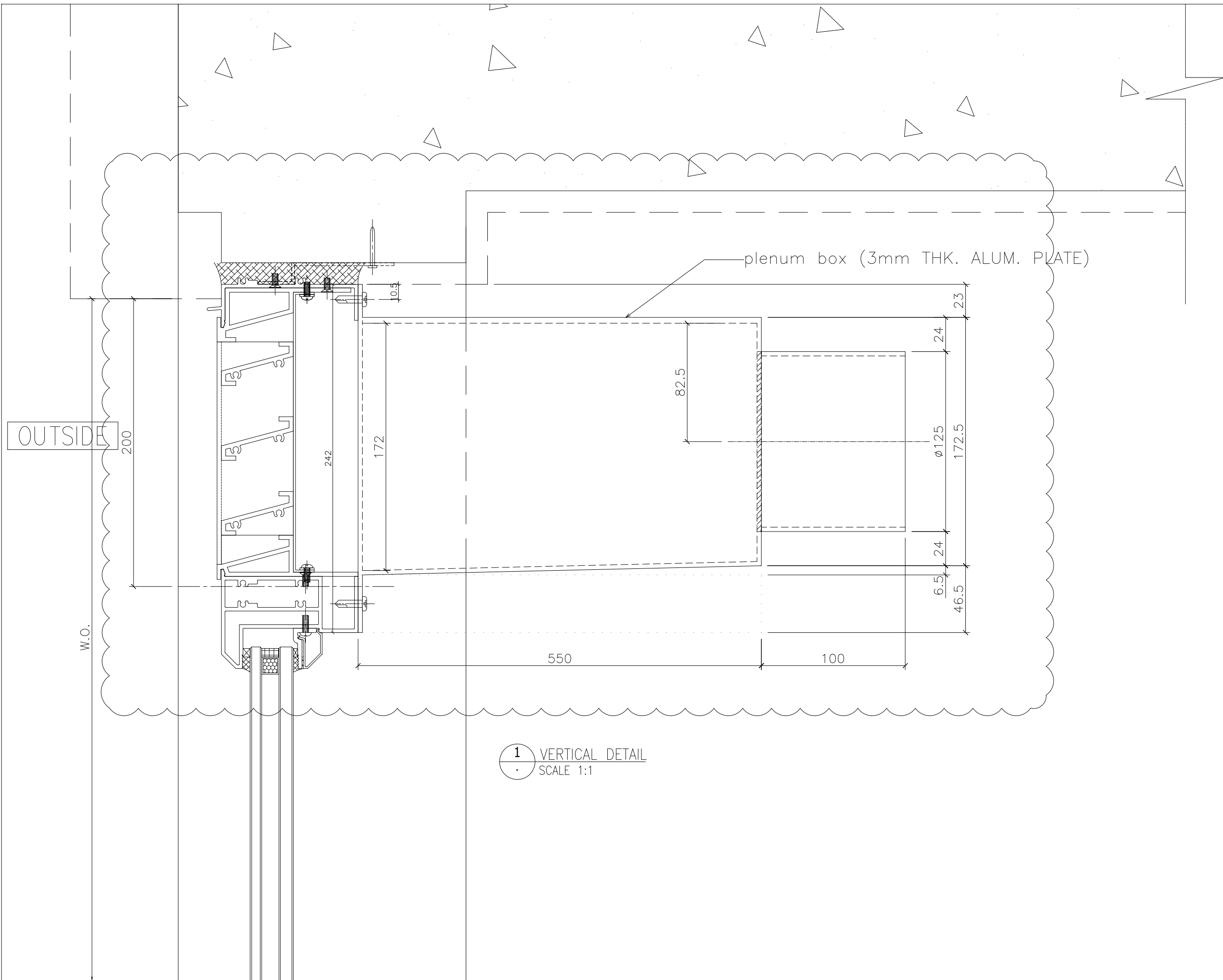

plenum box (3mm THK. ALUM. PLATE)

OUTSIDE

W.O.

1 VERTICAL DETAIL
SCALE 1:1

B.D. REF :

CLIENT :

ARCHITECT :
AGC DESIGN LTD
 180, 182, 184, 186, 188, 190, 192, 194, 196, 198, 200, 202, 204, 206, 208, 210, 212, 214, 216, 218, 220, 222, 224, 226, 228, 230, 232, 234, 236, 238, 240, 242, 244, 246, 248, 250, 252, 254, 256, 258, 260, 262, 264, 266, 268, 270, 272, 274, 276, 278, 280, 282, 284, 286, 288, 290, 292, 294, 296, 298, 300, 302, 304, 306, 308, 310, 312, 314, 316, 318, 320, 322, 324, 326, 328, 330, 332, 334, 336, 338, 340, 342, 344, 346, 348, 350, 352, 354, 356, 358, 360, 362, 364, 366, 368, 370, 372, 374, 376, 378, 380, 382, 384, 386, 388, 390, 392, 394, 396, 398, 400, 402, 404, 406, 408, 410, 412, 414, 416, 418, 420, 422, 424, 426, 428, 430, 432, 434, 436, 438, 440, 442, 444, 446, 448, 450, 452, 454, 456, 458, 460, 462, 464, 466, 468, 470, 472, 474, 476, 478, 480, 482, 484, 486, 488, 490, 492, 494, 496, 498, 500, 502, 504, 506, 508, 510, 512, 514, 516, 518, 520, 522, 524, 526, 528, 530, 532, 534, 536, 538, 540, 542, 544, 546, 548, 550, 552, 554, 556, 558, 560, 562, 564, 566, 568, 570, 572, 574, 576, 578, 580, 582, 584, 586, 588, 590, 592, 594, 596, 598, 600, 602, 604, 606, 608, 610, 612, 614, 616, 618, 620, 622, 624, 626, 628, 630, 632, 634, 636, 638, 640, 642, 644, 646, 648, 650, 652, 654, 656, 658, 660, 662, 664, 666, 668, 670, 672, 674, 676, 678, 680, 682, 684, 686, 688, 690, 692, 694, 696, 698, 700, 702, 704, 706, 708, 710, 712, 714, 716, 718, 720, 722, 724, 726, 728, 730, 732, 734, 736, 738, 740, 742, 744, 746, 748, 750, 752, 754, 756, 758, 760, 762, 764, 766, 768, 770, 772, 774, 776, 778, 780, 782, 784, 786, 788, 790, 792, 794, 796, 798, 800, 802, 804, 806, 808, 810, 812, 814, 816, 818, 820, 822, 824, 826, 828, 830, 832, 834, 836, 838, 840, 842, 844, 846, 848, 850, 852, 854, 856, 858, 860, 862, 864, 866, 868, 870, 872, 874, 876, 878, 880, 882, 884, 886, 888, 890, 892, 894, 896, 898, 900, 902, 904, 906, 908, 910, 912, 914, 916, 918, 920, 922, 924, 926, 928, 930, 932, 934, 936, 938, 940, 942, 944, 946, 948, 950, 952, 954, 956, 958, 960, 962, 964, 966, 968, 970, 972, 974, 976, 978, 980, 982, 984, 986, 988, 990, 992, 994, 996, 998, 1000

MAIN CONTRACTOR :
Gammon

STRUCTURAL ENGINEER :
ARUP

FACADE CONSULTANT:
MEINHARDT

NOTE :
 1. ALL DIMENSIONS ARE IN mm.
 2. ALL ELEVATIONS ARE VIEWED FROM OUTSIDE.
 3. ALL DIMENSIONS TO BE VERIFIED ON SITE BEFORE FABRICATION.

LEGEND :
 x1 --- DETAIL MARK NO.
 x001 --- REFER SHEET NO.

1. F.F.L. -- FINISHED FLOOR LEVEL
 2. S.F.L. -- STRUCTURAL FLOOR LEVEL
 3. (R) -- REVERSED DETAIL

A	09/12/2020	REVISION SUBJECT TO ARCH.COMMENT	lvn
NO.	DATE	REVISION	BY

JOB NO. : J-852

PROJECT :
 PROPOSED RESIDENTIAL DEVELOPMENT
 AT 139 - 147 ARGYLE STREET,
 NKIL 6005, 6035 R.P., 6036 R.P.,
 6037 R.P. & 6038 R.P.

TITLE :
 DETAIL FOR
 Plenum Box

DATE : 05-Dec-19 SCALE : 1:2

DRAWN BY : MN CHECKED BY : DW

美特鋁質有限公司
MIDI ALUMINIUM FABRICATOR LTD.
 Units 6-8, Sunray Industrial Centre, 1/F
 610 Cha Kwo Ling Road, Kowloon
 Tel:23489211-4 Fax:(852)2727666

DWG NO. : J852-SD-PB-6004 REV. : A

OUTSIDE

W.O.

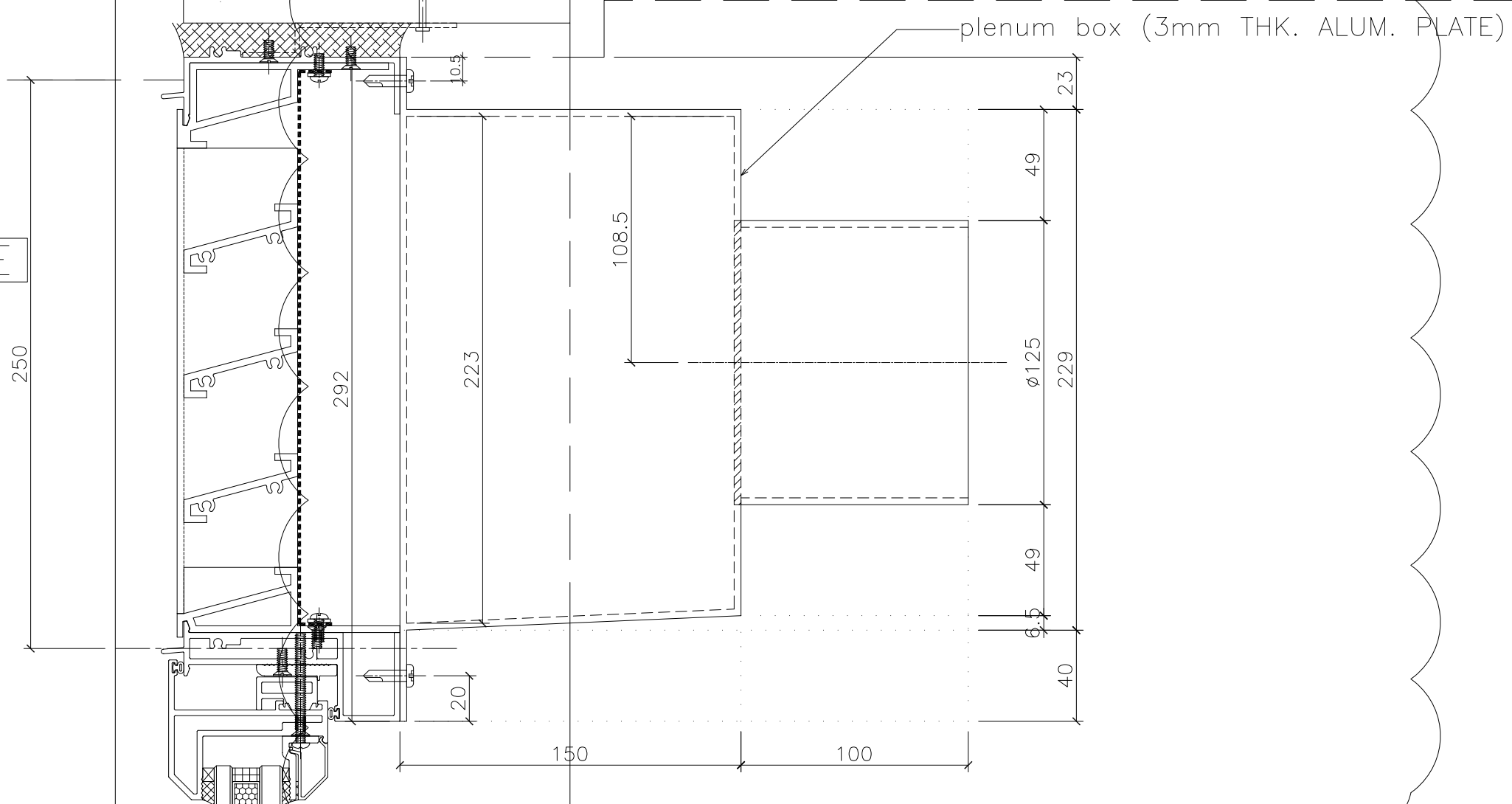

1 VERTICAL DETAIL
SCALE 1:1

B.D. REF :

CLIENT :

ARCHITECT :
AGC DESIGN LTD
 10/F, 107, Upper Ring Road, Hong Kong
 Tel: (852) 2511 1111 Fax: (852) 2511 1112 Email: agc@agc.com.hk

MAIN CONTRACTOR :
Gammon

STRUCTURAL ENGINEER :
ARUP

FACADE CONSULTANT:
MEINHARDT

NOTE :

1. ALL DIMENSIONS ARE IN mm.
2. ALL ELEVATIONS ARE VIEWED FROM OUTSIDE.
3. ALL DIMENSIONS TO BE VERIFIED ON SITE BEFORE FABRICATION.

LEGEND :

x1 — DETAIL MARK NO.
 x001 — REFER SHEET NO.

1. F.F.L. -- FINISHED FLOOR LEVEL
2. S.F.L. -- STRUCTURAL FLOOR LEVEL
3. (R) -- REVERSED DETAIL

NO.	DATE	REVISION	BY
A	09/12/2020	REVISION SUBJECT TO ARCH.COMMENT	lvart

JOB NO. : J-852

PROJECT :
 PROPOSED RESIDENTIAL DEVELOPMENT
 AT 139 - 147 ARGYLE STREET,
 NKIL 6005, 6035 R.P., 6036 R.P.,
 6037 R.P. & 6038 R.P.

TITLE :
 DETAIL FOR
 Plenum Box

DATE : 05-Dec-19 SCALE : 1:2

DRAWN BY : MN CHECKED BY : DW

美特鋁質有限公司
MIDI ALUMINIUM FABRICATOR LTD.
 Units 6-8, Sunray Industrial Centre, 1/F
 610 Cha Kwo Ling Road, Kowloon
 Tel:23489211-4 Fax:(852)2727666

DWG NO. : J852-SD-PB-6005 REV. : A

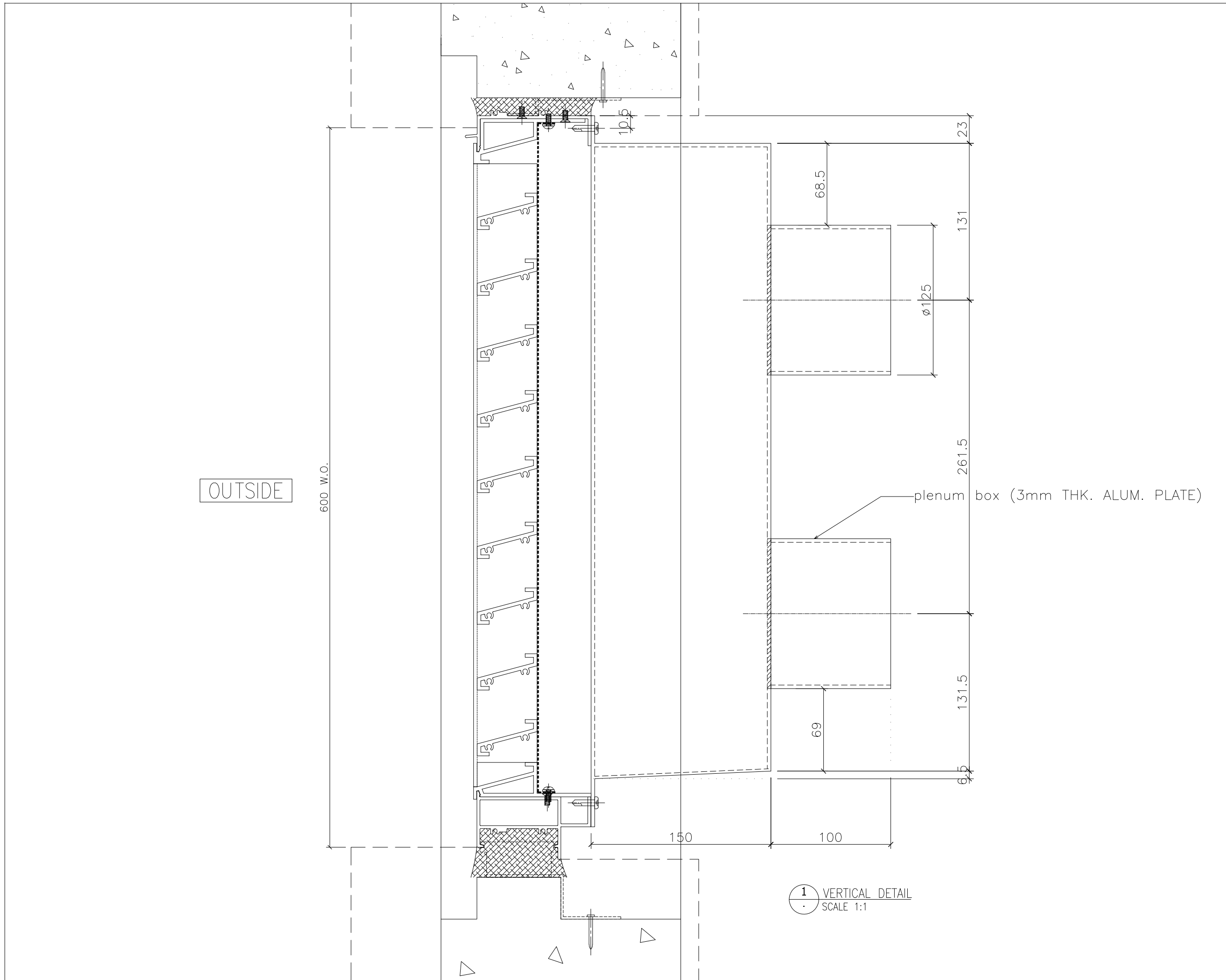

1 VERTICAL DETAIL
SCALE 1:1

B.D. REF :

CLIENT :

ARCHITECT :
AGC DESIGN LTD
 101, 102, 103, 104, 105, 106, 107, 108, 109, 110, 111, 112, 113, 114, 115, 116, 117, 118, 119, 120, 121, 122, 123, 124, 125, 126, 127, 128, 129, 130, 131, 132, 133, 134, 135, 136, 137, 138, 139, 140, 141, 142, 143, 144, 145, 146, 147, 148, 149, 150, 151, 152, 153, 154, 155, 156, 157, 158, 159, 160, 161, 162, 163, 164, 165, 166, 167, 168, 169, 170, 171, 172, 173, 174, 175, 176, 177, 178, 179, 180, 181, 182, 183, 184, 185, 186, 187, 188, 189, 190, 191, 192, 193, 194, 195, 196, 197, 198, 199, 200, 201, 202, 203, 204, 205, 206, 207, 208, 209, 210, 211, 212, 213, 214, 215, 216, 217, 218, 219, 220, 221, 222, 223, 224, 225, 226, 227, 228, 229, 230, 231, 232, 233, 234, 235, 236, 237, 238, 239, 240, 241, 242, 243, 244, 245, 246, 247, 248, 249, 250, 251, 252, 253, 254, 255, 256, 257, 258, 259, 260, 261, 262, 263, 264, 265, 266, 267, 268, 269, 270, 271, 272, 273, 274, 275, 276, 277, 278, 279, 280, 281, 282, 283, 284, 285, 286, 287, 288, 289, 290, 291, 292, 293, 294, 295, 296, 297, 298, 299, 300, 301, 302, 303, 304, 305, 306, 307, 308, 309, 310, 311, 312, 313, 314, 315, 316, 317, 318, 319, 320, 321, 322, 323, 324, 325, 326, 327, 328, 329, 330, 331, 332, 333, 334, 335, 336, 337, 338, 339, 340, 341, 342, 343, 344, 345, 346, 347, 348, 349, 350, 351, 352, 353, 354, 355, 356, 357, 358, 359, 360, 361, 362, 363, 364, 365, 366, 367, 368, 369, 370, 371, 372, 373, 374, 375, 376, 377, 378, 379, 380, 381, 382, 383, 384, 385, 386, 387, 388, 389, 390, 391, 392, 393, 394, 395, 396, 397, 398, 399, 400, 401, 402, 403, 404, 405, 406, 407, 408, 409, 410, 411, 412, 413, 414, 415, 416, 417, 418, 419, 420, 421, 422, 423, 424, 425, 426, 427, 428, 429, 430, 431, 432, 433, 434, 435, 436, 437, 438, 439, 440, 441, 442, 443, 444, 445, 446, 447, 448, 449, 450, 451, 452, 453, 454, 455, 456, 457, 458, 459, 460, 461, 462, 463, 464, 465, 466, 467, 468, 469, 470, 471, 472, 473, 474, 475, 476, 477, 478, 479, 480, 481, 482, 483, 484, 485, 486, 487, 488, 489, 490, 491, 492, 493, 494, 495, 496, 497, 498, 499, 500, 501, 502, 503, 504, 505, 506, 507, 508, 509, 510, 511, 512, 513, 514, 515, 516, 517, 518, 519, 520, 521, 522, 523, 524, 525, 526, 527, 528, 529, 530, 531, 532, 533, 534, 535, 536, 537, 538, 539, 540, 541, 542, 543, 544, 545, 546, 547, 548, 549, 550, 551, 552, 553, 554, 555, 556, 557, 558, 559, 560, 561, 562, 563, 564, 565, 566, 567, 568, 569, 570, 571, 572, 573, 574, 575, 576, 577, 578, 579, 580, 581, 582, 583, 584, 585, 586, 587, 588, 589, 590, 591, 592, 593, 594, 595, 596, 597, 598, 599, 600, 601, 602, 603, 604, 605, 606, 607, 608, 609, 610, 611, 612, 613, 614, 615, 616, 617, 618, 619, 620, 621, 622, 623, 624, 625, 626, 627, 628, 629, 630, 631, 632, 633, 634, 635, 636, 637, 638, 639, 640, 641, 642, 643, 644, 645, 646, 647, 648, 649, 650, 651, 652, 653, 654, 655, 656, 657, 658, 659, 660, 661, 662, 663, 664, 665, 666, 667, 668, 669, 670, 671, 672, 673, 674, 675, 676, 677, 678, 679, 680, 681, 682, 683, 684, 685, 686, 687, 688, 689, 690, 691, 692, 693, 694, 695, 696, 697, 698, 699, 700, 701, 702, 703, 704, 705, 706, 707, 708, 709, 710, 711, 712, 713, 714, 715, 716, 717, 718, 719, 720, 721, 722, 723, 724, 725, 726, 727, 728, 729, 730, 731, 732, 733, 734, 735, 736, 737, 738, 739, 740, 741, 742, 743, 744, 745, 746, 747, 748, 749, 750, 751, 752, 753, 754, 755, 756, 757, 758, 759, 760, 761, 762, 763, 764, 765, 766, 767, 768, 769, 770, 771, 772, 773, 774, 775, 776, 777, 778, 779, 780, 781, 782, 783, 784, 785, 786, 787, 788, 789, 790, 791, 792, 793, 794, 795, 796, 797, 798, 799, 800, 801, 802, 803, 804, 805, 806, 807, 808, 809, 810, 811, 812, 813, 814, 815, 816, 817, 818, 819, 820, 821, 822, 823, 824, 825, 826, 827, 828, 829, 830, 831, 832, 833, 834, 835, 836, 837, 838, 839, 840, 841, 842, 843, 844, 845, 846, 847, 848, 849, 850, 851, 852, 853, 854, 855, 856, 857, 858, 859, 860, 861, 862, 863, 864, 865, 866, 867, 868, 869, 870, 871, 872, 873, 874, 875, 876, 877, 878, 879, 880, 881, 882, 883, 884, 885, 886, 887, 888, 889, 890, 891, 892, 893, 894, 895, 896, 897, 898, 899, 900, 901, 902, 903, 904, 905, 906, 907, 908, 909, 910, 911, 912, 913, 914, 915, 916, 917, 918, 919, 920, 921, 922, 923, 924, 925, 926, 927, 928, 929, 930, 931, 932, 933, 934, 935, 936, 937, 938, 939, 940, 941, 942, 943, 944, 945, 946, 947, 948, 949, 950, 951, 952, 953, 954, 955, 956, 957, 958, 959, 960, 961, 962, 963, 964, 965, 966, 967, 968, 969, 970, 971, 972, 973, 974, 975, 976, 977, 978, 979, 980, 981, 982, 983, 984, 985, 986, 987, 988, 989, 990, 991, 992, 993, 994, 995, 996, 997, 998, 999, 1000

NOTE :

1. ALL DIMENSIONS ARE IN mm.
2. ALL ELEVATIONS ARE VIEWED FROM OUTSIDE.
3. ALL DIMENSIONS TO BE VERIFIED ON SITE BEFORE FABRICATION.

LEGEND :

x1 — DETAIL MARK NO.
 x001 — REFER SHEET NO.

1. F.F.L. -- FINISHED FLOOR LEVEL
2. S.F.L. -- STRUCTURAL FLOOR LEVEL
3. (A) -- REVERSED DETAIL

NO.	DATE	REVISED	BY
JOB NO. :		J-852	
PROJECT :			
PROPOSED RESIDENTIAL DEVELOPMENT AT 139 - 147 ARGYLE STREET, NKIL 6005, 6035 R.P., 6036 R.P., 6037 R.P. & 6038 R.P.			
TITLE :			
DETAIL FOR Plenum Box			
DATE : 05-Dec-19		SCALE : 1:2	
DRAWN BY : MN		CHECKED BY : DW	
美特鋁質有限公司 MIDI ALUMINIUM FABRICATOR LTD. Units 6-8, Sunray Industrial Centre, 1/F 610 Cha Kwo Ling Road, Kowloon Tel:23489211-4 Fax:(852)2727666			
DWG NO. : J852-SD-PB-6006		REV. : -	

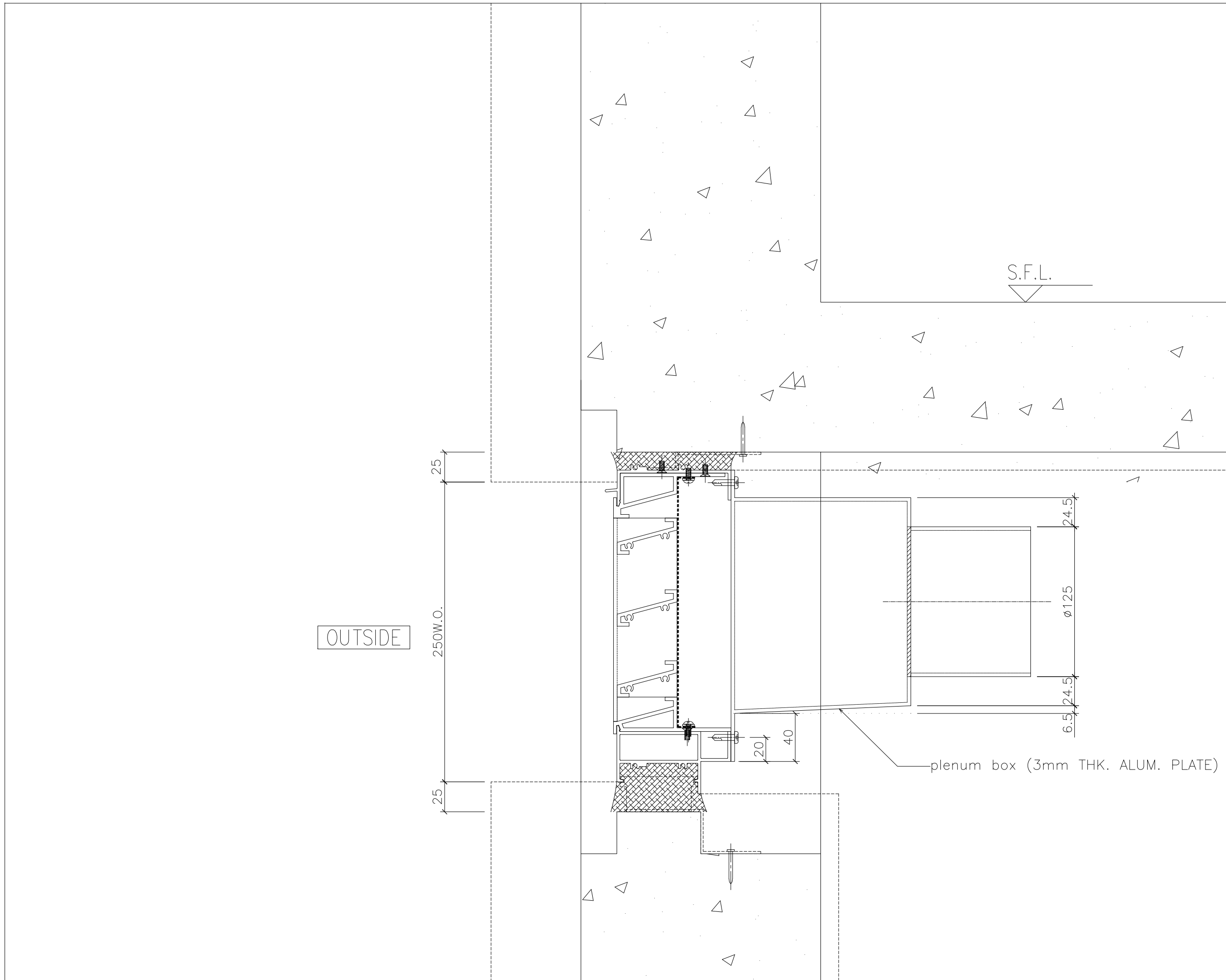

B.D. REF :

CLIENT :

ARCHITECT :
AGC DESIGN LTD
 香港建築師學會會員
 181, 182, 183, 184, 185, 186, 187, 188, 189, 190, 191, 192, 193, 194, 195, 196, 197, 198, 199, 200, 201, 202, 203, 204, 205, 206, 207, 208, 209, 210, 211, 212, 213, 214, 215, 216, 217, 218, 219, 220, 221, 222, 223, 224, 225, 226, 227, 228, 229, 230, 231, 232, 233, 234, 235, 236, 237, 238, 239, 240, 241, 242, 243, 244, 245, 246, 247, 248, 249, 250, 251, 252, 253, 254, 255, 256, 257, 258, 259, 260, 261, 262, 263, 264, 265, 266, 267, 268, 269, 270, 271, 272, 273, 274, 275, 276, 277, 278, 279, 280, 281, 282, 283, 284, 285, 286, 287, 288, 289, 290, 291, 292, 293, 294, 295, 296, 297, 298, 299, 300, 301, 302, 303, 304, 305, 306, 307, 308, 309, 310, 311, 312, 313, 314, 315, 316, 317, 318, 319, 320, 321, 322, 323, 324, 325, 326, 327, 328, 329, 330, 331, 332, 333, 334, 335, 336, 337, 338, 339, 340, 341, 342, 343, 344, 345, 346, 347, 348, 349, 350, 351, 352, 353, 354, 355, 356, 357, 358, 359, 360, 361, 362, 363, 364, 365, 366, 367, 368, 369, 370, 371, 372, 373, 374, 375, 376, 377, 378, 379, 380, 381, 382, 383, 384, 385, 386, 387, 388, 389, 390, 391, 392, 393, 394, 395, 396, 397, 398, 399, 400, 401, 402, 403, 404, 405, 406, 407, 408, 409, 410, 411, 412, 413, 414, 415, 416, 417, 418, 419, 420, 421, 422, 423, 424, 425, 426, 427, 428, 429, 430, 431, 432, 433, 434, 435, 436, 437, 438, 439, 440, 441, 442, 443, 444, 445, 446, 447, 448, 449, 450, 451, 452, 453, 454, 455, 456, 457, 458, 459, 460, 461, 462, 463, 464, 465, 466, 467, 468, 469, 470, 471, 472, 473, 474, 475, 476, 477, 478, 479, 480, 481, 482, 483, 484, 485, 486, 487, 488, 489, 490, 491, 492, 493, 494, 495, 496, 497, 498, 499, 500, 501, 502, 503, 504, 505, 506, 507, 508, 509, 510, 511, 512, 513, 514, 515, 516, 517, 518, 519, 520, 521, 522, 523, 524, 525, 526, 527, 528, 529, 530, 531, 532, 533, 534, 535, 536, 537, 538, 539, 540, 541, 542, 543, 544, 545, 546, 547, 548, 549, 550, 551, 552, 553, 554, 555, 556, 557, 558, 559, 560, 561, 562, 563, 564, 565, 566, 567, 568, 569, 570, 571, 572, 573, 574, 575, 576, 577, 578, 579, 580, 581, 582, 583, 584, 585, 586, 587, 588, 589, 590, 591, 592, 593, 594, 595, 596, 597, 598, 599, 600, 601, 602, 603, 604, 605, 606, 607, 608, 609, 610, 611, 612, 613, 614, 615, 616, 617, 618, 619, 620, 621, 622, 623, 624, 625, 626, 627, 628, 629, 630, 631, 632, 633, 634, 635, 636, 637, 638, 639, 640, 641, 642, 643, 644, 645, 646, 647, 648, 649, 650, 651, 652, 653, 654, 655, 656, 657, 658, 659, 660, 661, 662, 663, 664, 665, 666, 667, 668, 669, 670, 671, 672, 673, 674, 675, 676, 677, 678, 679, 680, 681, 682, 683, 684, 685, 686, 687, 688, 689, 690, 691, 692, 693, 694, 695, 696, 697, 698, 699, 700, 701, 702, 703, 704, 705, 706, 707, 708, 709, 710, 711, 712, 713, 714, 715, 716, 717, 718, 719, 720, 721, 722, 723, 724, 725, 726, 727, 728, 729, 730, 731, 732, 733, 734, 735, 736, 737, 738, 739, 740, 741, 742, 743, 744, 745, 746, 747, 748, 749, 750, 751, 752, 753, 754, 755, 756, 757, 758, 759, 760, 761, 762, 763, 764, 765, 766, 767, 768, 769, 770, 771, 772, 773, 774, 775, 776, 777, 778, 779, 780, 781, 782, 783, 784, 785, 786, 787, 788, 789, 790, 791, 792, 793, 794, 795, 796, 797, 798, 799, 800, 801, 802, 803, 804, 805, 806, 807, 808, 809, 810, 811, 812, 813, 814, 815, 816, 817, 818, 819, 820, 821, 822, 823, 824, 825, 826, 827, 828, 829, 830, 831, 832, 833, 834, 835, 836, 837, 838, 839, 840, 841, 842, 843, 844, 845, 846, 847, 848, 849, 850, 851, 852, 853, 854, 855, 856, 857, 858, 859, 860, 861, 862, 863, 864, 865, 866, 867, 868, 869, 870, 871, 872, 873, 874, 875, 876, 877, 878, 879, 880, 881, 882, 883, 884, 885, 886, 887, 888, 889, 890, 891, 892, 893, 894, 895, 896, 897, 898, 899, 900, 901, 902, 903, 904, 905, 906, 907, 908, 909, 910, 911, 912, 913, 914, 915, 916, 917, 918, 919, 920, 921, 922, 923, 924, 925, 926, 927, 928, 929, 930, 931, 932, 933, 934, 935, 936, 937, 938, 939, 940, 941, 942, 943, 944, 945, 946, 947, 948, 949, 950, 951, 952, 953, 954, 955, 956, 957, 958, 959, 960, 961, 962, 963, 964, 965, 966, 967, 968, 969, 970, 971, 972, 973, 974, 975, 976, 977, 978, 979, 980, 981, 982, 983, 984, 985, 986, 987, 988, 989, 990, 991, 992, 993, 994, 995, 996, 997, 998, 999, 1000

MAIN CONTRACTOR :
Gammon

STRUCTURAL ENGINEER :
ARUP

FACADE CONSULTANT:
MEINHARDT

NOTE :

1. ALL DIMENSIONS ARE IN mm.
2. "ALL ELEVATIONS ARE VIEWED FROM OUTSIDE."
3. ALL DIMENSIONS TO BE VERIFIED ON SITE BEFORE FABRICATION.

LEGEND :

x1 — DETAIL MARK NO.
 x001 — REFER SHEET NO.

1. F.F.L. -- FINISHED FLOOR LEVEL
2. S.F.L. -- STRUCTURAL FLOOR LEVEL
3. (R) -- REVERSED DETAIL

NO.	DATE	REVISED	BY
JOB NO. : J-852			
PROJECT : PROPOSED RESIDENTIAL DEVELOPMENT AT 139 - 147 ARGYLE STREET, NKIL 6005, 6035 R.P., 6036 R.P., 6037 R.P. & 6038 R.P.			
TITLE : DETAIL FOR Plenum Box			
DATE : 05-Dec-19		SCALE : 1:2	
DRAWN BY : MN		CHECKED BY : DW	
美特鋁質有限公司 MIDI ALUMINIUM FABRICATOR LTD. Units 6-8, Sunray Industrial Centre, 1/F 610 Cha Kwo Ling Road, Kowloon Tel:23489211-4 Fax:(852)2727666			
DWG NO. : J852-SD-PB-6007			REV. : -