

工程指示 / 要求簡箋(E.I.)

工程指示編號：EI / 2809 / 20

修改版次：A

工程編號：J - 852

工程名稱：亞皆老街中電

工程項目：大樓 偏林箱 圖紙

收件人：生統 / 胡冬雲

發件人：Ant Yeung

日期：07/04/2021

要求提供 / 確認 事項：

- | | | |
|------------------------------------|-------------------------------------|-------------------------------|
| <input type="checkbox"/> 初步鋁料 B.M. | <input type="checkbox"/> 加工拆圖，然後生產 | <input type="checkbox"/> 尺寸表 |
| <input type="checkbox"/> 正式鋁料 B.M. | <input type="checkbox"/> 技術上資料 / 指示 | <input type="checkbox"/> 報價 |
| <input type="checkbox"/> 配件 B.M. | <input type="checkbox"/> 樣辦或貨品說明書 | <input type="checkbox"/> 分判合約 |
| <input type="checkbox"/> 其他：_____ | | |

內容：

A 版:附上最新大圖，請覆核加工圖

請按附上大樓偏林箱圖紙，為生產分判 樣板層: T1,T2,T3, 5/F

T1 = 138 個

T2 = 137 個

T3 = 153 個 合共 428 個偏林箱

優先生產 T3, 5/F 數量交現場樣板層安裝

大貨 10 層一批，第一批預 2 月頭至中，實際日期到貨由地盤安排

分判：請先交樣板。 謝謝

請在 2021.04.10 前完成上列要求。

附：大圖 + CAD 檔

以上項目為：

- 原合約工程包 原合約工程加 / 減賬 新工程報價

原因：-

分發東莞各部門：

- | | | | |
|--|--|--|---|
| <input type="checkbox"/> 生產技術總監 <input type="checkbox"/> 連附件 | <input type="checkbox"/> 技術部 <input type="checkbox"/> 連附件 | <input type="checkbox"/> 生產部 <input type="checkbox"/> 連附件 | <input type="checkbox"/> 機械設計部 <input type="checkbox"/> 連附件 |
| <input type="checkbox"/> 採購部 <input type="checkbox"/> 連附件 | <input checked="" type="checkbox"/> 生產統籌部 <input checked="" type="checkbox"/> 連附件 <i>楊</i> | <input type="checkbox"/> 清 & 小羅 <input type="checkbox"/> 連附件 | |
| <input type="checkbox"/> 質檢部 <input type="checkbox"/> 連附件 | <input type="checkbox"/> 會計部 <input type="checkbox"/> 連附件 | <input type="checkbox"/> 報關組 <input type="checkbox"/> 連附件 | <input checked="" type="checkbox"/> 其他 <i>胡冬雲</i> <i>楊榮輝</i> <input type="checkbox"/> 連附件 |

分發其他分判：

- 水洪 連附件

分發香港各部門：

- | | | | |
|---|--|---|--|
| <input type="checkbox"/> 行政部 <input type="checkbox"/> 連附件 | <input type="checkbox"/> 會計部 <input type="checkbox"/> 連附件 | <input type="checkbox"/> 統籌部 <input type="checkbox"/> 連附件 | <input type="checkbox"/> 工程部地盤科文 <input type="checkbox"/> 連附件 |
| <input type="checkbox"/> 採購部 <input type="checkbox"/> 連附件 | <input type="checkbox"/> QS 部 <input type="checkbox"/> 連附件 | <input type="checkbox"/> 維修部 <input type="checkbox"/> 連附件 | <input type="checkbox"/> 其他 _____ <input type="checkbox"/> 連附件 |

傳遞編號：

HK 0715 / 2021

發件人簽署：

項目經理簽署：

Ant Yeung
Project Manager

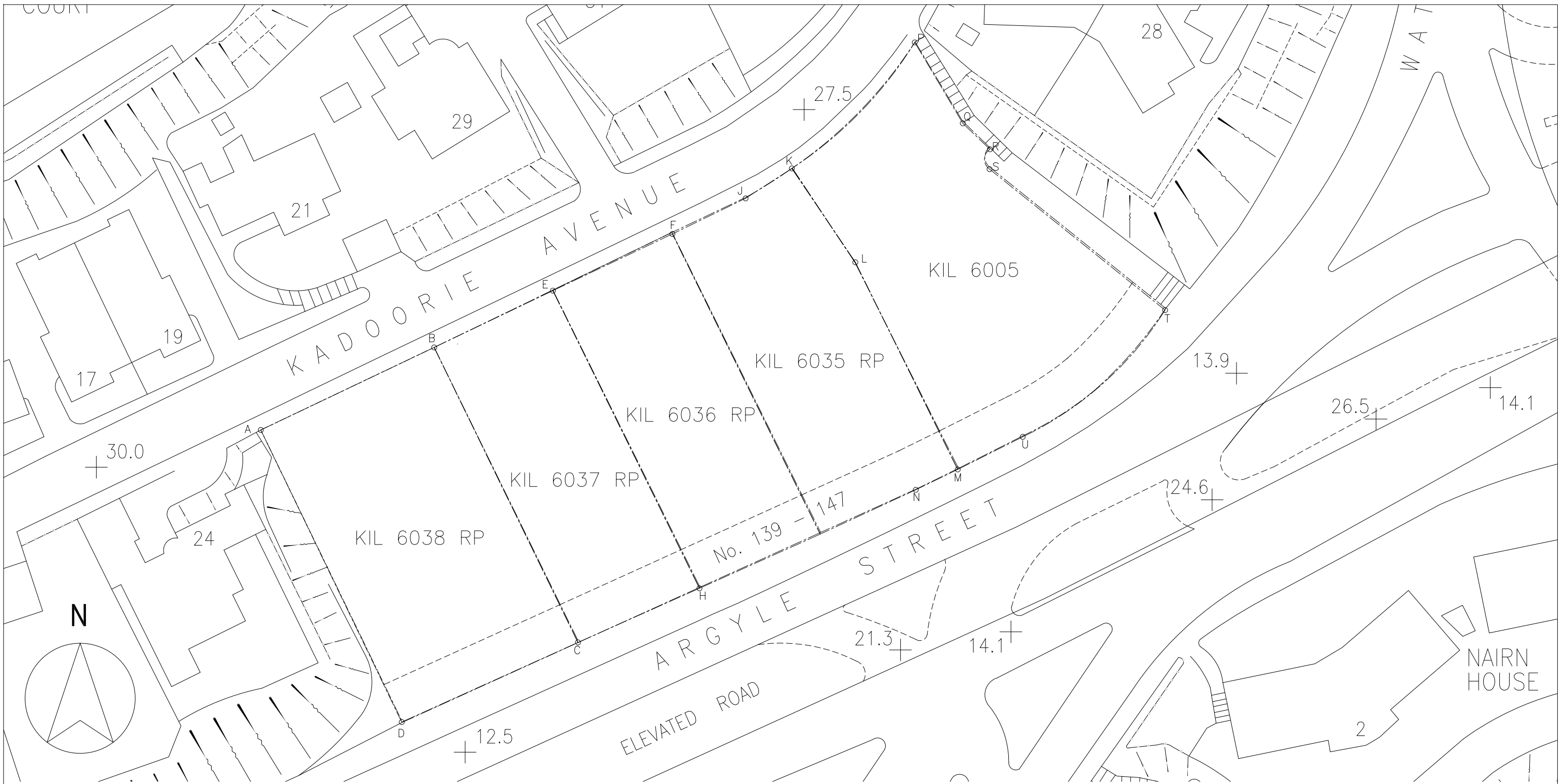

**PROJECT : PROPOSED RESIDENTIAL DEVELOPMENT AT 139 - 147 ARGYLE STREET,
NKIL 6005, 6035 R.P., 6036 R.P., 6037 R.P. & 6038 R.P.**

6

**TITLE : Plenum box
SHOPDRAWING SUBMISSION**

DATE: 23-March - 2021

DRAWING SUBMISSION REGISTER

PROJECT: PROPOSED RESIDENTIAL DEVELOPMENT AT 139-147 ARGYLE STREET, NKIL 6006, 6035 R.P., 6036 R.P., TITLE: PLENUM BOX AT PRECAST FACADE AND IN-SITU WINDOW SHOPDRAWING SUBMISSION											SUBMISSION STATE (FOR B.D / A.S.D)			SUBMISSION STATE (FOR CLIENT / CONSULTANT)			SUBMISSION STATE (FOR ARCHITECT)			FABRICATION / CONSTRUCTION STATE						
	ISSUE	1	2	3	4	5	6					AP - APPROVED			AP - APPROVED			AP - APPROVED			ISSUE TO CHINA OFFICE		ISSUE TO SITE		ISSUE TO SUB-CONTRACTOR	
	DAY	15	8	14	4	5	23					AC - APPROVED SUB. TO CONDITION			AC - APPROVED SUB. TO CONDITION			AC - APPROVED SUB. TO CONDITION								
	MONTH	8	12	1	2	3	3					NA - NOT APPROVED			NA - NOT APPROVED			NA - NOT APPROVED								
	YEAR	20	20	21	21	21	21																			
DRAWING TITLE	DWG. NO.	REVISIONS										COMMENT DATE	REV.	STATE	COMMENT DATE	REV.	STATE	COMMENT DATE	REV.	STATE	REV.	DATE	REV.	DATE	REV.	DATE
COVER PAGE	J852-SD-PB-0000	-	A	B	C	C	D																			
DRAWING REGISTER	J852-SD-PB-0001	-	-	-	-	-	-																			
DRAWING REGISTER	J852-SD-PB-0002	-	-	-	-	-	-																			
DRAWING REGISTER	J852-SD-PB-0003	-	-	-	-	-	-																			
BUILDING ELEVATION FOR TOWER 1 · 2&3	J852-SD-PB-2001	-	-	-	-	-	-																			
BUILDING ELEVATION FOR TOWER 1 · 2&3	J852-SD-PB-2002	-	-	-	-	-	-																			
BUILDING ELEVATION FOR TOWER 1 · 2&3	J852-SD-PB-2003	-	-	-	-	-	-																			
PART PLAN OF TOWER 1 (1/F)	J852-SD-PB-3001	-	A	B	B	B	B																			
PART PLAN OF TOWER 1 (2-21/F)	J852-SD-PB-3002	-	A	B	B	B	B																			
PART PLAN OF TOWER 1 (22/F)	J852-SD-PB-3003	-	A	B	B	B	B																			
PART PLAN OF TOWER 1 (23/F)	J852-SD-PB-3004	-	-	A	A	A	A																			
PART PLAN OF TOWER 2 (1/F)	J852-SD-PB-3005	-	-	-	-	-	-																			
PART PLAN OF TOWER 2 (2-21/F)	J852-SD-PB-3006	-	-	-	-	-	-																			
PART PLAN OF TOWER 2 (22/F)	J852-SD-PB-3007	-	A	A	A	A	A																			
PART PLAN OF TOWER 2 (23/F)	J852-SD-PB-3008	-	-	A	A	A	A																			
PART PLAN OF TOWER 3 (1/F)	J852-SD-PB-3009	-	A	A	A	A	A																			
PART PLAN OF TOWER 3 (2-21/F)	J852-SD-PB-3010	-	A	B	B	B	B																			
PART PLAN OF TOWER 3 (23/F)	J852-SD-PB-3011	-	-	A	A	A	A																			
PART PLAN OF TOWER 3 (23/F)	J852-SD-PB-3012	-	-	A	A	A	A																			
SCHEDULE FOR Plenum Box AT TOWER 1 (1-21F)	J852-SD-PB-4101	-	A	A	A	A	A																			
SCHEDULE FOR Plenum Box AT TOWER 1 (1-21F)	J852-SD-PB-4101A	-	A	A	A	A	A																			
SCHEDULE FOR Plenum Box AT TOWER 1 (1-21F)	J852-SD-PB-4102	-	A	A	A	A	A																			
SCHEDULE FOR Plenum Box AT TOWER 1 (1-21F)	J852-SD-PB-4102A	-	A	A	A	A	A																			
SCHEDULE FOR Plenum Box AT TOWER 1 (1-21F)	J852-SD-PB-4103	-	A	A	A	B	B																			
SCHEDULE FOR Plenum Box AT TOWER 1 (1-21F)	J852-SD-PB-4103A	-	A	A	A	B	B																			
SCHEDULE FOR Plenum Box AT TOWER 1 (1-21F)	J852-SD-PB-4104	-	A	B	B	B	C																			
SCHEDULE FOR Plenum Box AT TOWER 1 (1-21F)	J852-SD-PB-4104A	-	A	B	B	B	C																			
SCHEDULE FOR Plenum Box AT TOWER 1 (1-21F)	J852-SD-PB-4105	-	A	A	A	A	A																			
SCHEDULE FOR Plenum Box AT TOWER 1 (1-21F)	J852-SD-PB-4106	-	-	A	A	A	A																			
SCHEDULE FOR Plenum Box AT TOWER 1 (22F)	J852-SD-PB-4107	-	A	B	B	B	B																			
SCHEDULE FOR Plenum Box AT TOWER 1 (22F)	J852-SD-PB-4108	-	A	A	A	B	B																			
SCHEDULE FOR Plenum Box AT TOWER 1 (22F)	J852-SD-PB-4109	-	A	A	A	A	A																			
SCHEDULE FOR Plenum Box AT TOWER 1 (22F)	J852-SD-PB-4110	-	A	A	A	A	A																			
SCHEDULE FOR Plenum Box AT TOWER 1 (22F)	J852-SD-PB-4111	-	A	A	B	B	B																			
SCHEDULE FOR Plenum Box AT TOWER 1 (23F)	J852-SD-PB-4112	-	A	B	B	B	B																			
SCHEDULE FOR Plenum Box AT TOWER 1 (23F)	J852-SD-PB-4113	-	A	B	B	C	C																			
SCHEDULE FOR Plenum Box AT TOWER 1 (23F)	J852-SD-PB-4114	-	-	-	-	-	-																			
SCHEDULE FOR Plenum Box AT TOWER 1 (23F)	J852-SD-PB-4115	-	-	-	-	-	-																			
SCHEDULE FOR Plenum Box AT TOWER 1 (23F)	J852-SD-PB-4116	-	-	A	A	A	A																			
SCHEDULE FOR Plenum Box AT TOWER 2 (1-21F)	J852-SD-PB-4201	-	A	B	B	C	C																			
SCHEDULE FOR Plenum Box AT TOWER 2 (1-21F)	J852-SD-PB-4201A	-	A	B	B	C	C																			
SCHEDULE FOR Plenum Box AT TOWER 2 (1-21F)	J852-SD-PB-4202	-	A	B	B	B	C																			
SCHEDULE FOR Plenum Box AT TOWER 2 (1-21F)	J852-SD-PB-4202A	-	A	B	B	B	C																			
SCHEDULE FOR Plenum Box AT TOWER 2 (1-21F)	J852-SD-PB-4203	-	A	B	B	B	C																			

IN-HOUSE DESIGN CHECKER



MIDI ALUMINIUM FABRICATOR LTD.
 Units 6-8, Sunray Industrial Centre, 1/F
 610 Cha Kwo Ling Road, Kowloon
 Tel:23489211-4 Fax:(852)27727666

DWG NO. : J852-SD-PB-0001 REV. : -

DRAWING SUBMISSION REGISTER

PROJECT: PROPOSED RESIDENTIAL DEVELOPMENT AT 139-147 ARGYLE STREET, NKIL 6006, 6035 R.P., 6036 R.P., TITLE: PLENUM BOX AT PRECAST FACADE AND IN-SITU WINDOW SHOPDRAWING SUBMISSION	DATE OF ISSUE										SUBMISSION STATE (FOR B.D / A.S.D)			SUBMISSION STATE (FOR CLIENT / CONSULTANT)			SUBMISSION STATE (FOR ARCHITECT)			FABRICATION / CONSTRUCTION STATE						
	ISSUE	1	2	3	4	5	6					AP - APPROVED			AP - APPROVED			AP - APPROVED			ISSUE TO CHINA OFFICE		ISSUE TO SITE		ISSUE TO SUB-CONTRACTOR	
	DAY	15	9	14	4	5	23					AC - APPROVED SUB. TO CONDITION			AC - APPROVED SUB. TO CONDITION			AC - APPROVED SUB. TO CONDITION								
	MONTH	8	12	1	2	3	3					NA - NOT APPROVED			NA - NOT APPROVED			NA - NOT APPROVED								
	YEAR	20	20	21	21	21	21																			
DRAWING TITLE	DWG. NO.	REVISIONS									COMMENT DATE	REV.	STATE	COMMENT DATE	REV.	STATE	COMMENT DATE	REV.	STATE	REV.	DATE	REV.	DATE	REV.	DATE	
SCHEDULE FOR Plenum Box AT TOWER 2 (1-21F)	J852-SD-PB-4203A	-	A	B	B	B	C																			
SCHEDULE FOR Plenum Box AT TOWER 2 (1-21F)	J852-SD-PB-4204	-	A	A	A	A	A																			
SCHEDULE FOR Plenum Box AT TOWER 2 (1-21F)	J852-SD-PB-4205	-	A	A	A	A	A																			
SCHEDULE FOR Plenum Box AT TOWER 2 (22F)	J852-SD-PB-4206	-	A	B	B	C	C																			
SCHEDULE FOR Plenum Box AT TOWER 2 (22F)	J852-SD-PB-4207	-	A	B	B	B	C																			
SCHEDULE FOR Plenum Box AT TOWER 2 (22F)	J852-SD-PB-4208	-	A	B	B	B	C																			
SCHEDULE FOR Plenum Box AT TOWER 2 (22F)	J852-SD-PB-4209	-	A	A	A	A	A																			
SCHEDULE FOR Plenum Box AT TOWER 2 (22F)	J852-SD-PB-4210	-	A	A	A	A	A																			
SCHEDULE FOR Plenum Box AT TOWER 2 (23F)	J852-SD-PB-4211	-	A	B	B	B	B																			
SCHEDULE FOR Plenum Box AT TOWER 2 (23F)	J852-SD-PB-4212	-	A	B	B	B	B																			
SCHEDULE FOR Plenum Box AT TOWER 2 (23F)	J852-SD-PB-4213	-	A	A	A	B	B																			
SCHEDULE FOR Plenum Box AT TOWER 2 (23F)	J852-SD-PB-4214	-	A	A	A	A	B																			
SCHEDULE FOR Plenum Box AT TOWER 2 (23F)	J852-SD-PB-4215	-	A	A	A	A	A																			
SCHEDULE FOR Plenum Box AT TOWER 3 (1-21F)	J852-SD-PB-4301	-	A	A	A	A	A																			
SCHEDULE FOR Plenum Box AT TOWER 3 (1-21F)	J852-SD-PB-4302	-	A	A	A	A	A																			
SCHEDULE FOR Plenum Box AT TOWER 3 (1-21F)	J852-SD-PB-4303	-	A	A	A	B	B																			
SCHEDULE FOR Plenum Box AT TOWER 3 (1-21F)	J852-SD-PB-4304	-	A	B	B	B	C																			
SCHEDULE FOR Plenum Box AT TOWER 3 (1-21F)	J852-SD-PB-4305	-	A	A	A	A	A																			
SCHEDULE FOR Plenum Box AT TOWER 3 (1-21F)	J852-SD-PB-4306	-	A	A	A	A	A																			
SCHEDULE FOR Plenum Box AT TOWER 3 (1-21F)	J852-SD-PB-4307	-	-	A	A	A	A																			
SCHEDULE FOR Plenum Box AT TOWER 3 (1-21F)	J852-SD-PB-4308	-	-	A	A	A	A																			
SCHEDULE FOR Plenum Box AT TOWER 3 (22F)	J852-SD-PB-4309	-	A	A	A	A	A																			
SCHEDULE FOR Plenum Box AT TOWER 3 (22F)	J852-SD-PB-4310	-	A	A	A	B	B																			
SCHEDULE FOR Plenum Box AT TOWER 3 (22F)	J852-SD-PB-4311	-	A	B	B	B	B																			
SCHEDULE FOR Plenum Box AT TOWER 3 (22F)	J852-SD-PB-4312	-	A	A	A	A	A																			
SCHEDULE FOR Plenum Box AT TOWER 3 (22F)	J852-SD-PB-4313	-	A	B	B	B	B																			
SCHEDULE FOR Plenum Box AT TOWER 3 (23F)	J852-SD-PB-4314	-	A	A	A	A	A																			
SCHEDULE FOR Plenum Box AT TOWER 3 (23F)	J852-SD-PB-4315	-	-	-	-	A	A																			
SCHEDULE FOR Plenum Box AT TOWER 3 (23F)	J852-SD-PB-4316	-	-	A	A	A	A																			
SCHEDULE FOR Plenum Box AT TOWER 3 (23F)	J852-SD-PB-4317	-	-	-	-	-	-																			
SCHEDULE FOR Plenum Box AT TOWER 3 (23F)	J852-SD-PB-4318	-	-	A	A	A	A																			
DETAIL FOR Plenum Box	J852-SD-PB-5001	-	A	A	A	A	A																			
DETAIL FOR Plenum Box	J852-SD-PB-5001a	-	-	-	-	A	A																			
DETAIL FOR Plenum Box	J852-SD-PB-5002	-	A	A	A	A	A																			
DETAIL FOR Plenum Box	J852-SD-PB-5002a	-	-	A	A	A	A																			
DETAIL FOR Plenum Box	J852-SD-PB-5002b	-	-	-	-	-	-																			
DETAIL FOR Plenum Box	J852-SD-PB-5002c	-	-	-	-	-	-																			
DETAIL FOR Plenum Box	J852-SD-PB-5003	-	A	B	B	B	C																			
DETAIL FOR Plenum Box	J852-SD-PB-5003a	-	-	-	-	-	-																			
DETAIL FOR Plenum Box	J852-SD-PB-5004	-	A	A	A	A	A																			
DETAIL FOR Plenum Box	J852-SD-PB-5005	-	A	A	A	A	A																			
DETAIL FOR Plenum Box	J852-SD-PB-5006	-	-	-	-	-	-																			
DETAIL FOR Plenum Box	J852-SD-PB-5007	-	A	B	B	B	B																			

IN-HOUSE DESIGN CHECKER
 MIDI ALUMINIUM FABRICATOR LTD. Units 6-8, Sunray Industrial Centre, 1/F 610 Cha Kwo Ling Road, Kowloon Tel:23489211-4 Fax:(852)27727666
DWG NO. : J852-SD-PB-0002 REV. : -

DRAWING SUBMISSION REGISTER

PROJECT: PROPOSED RESIDENTIAL DEVELOPMENT AT 139-147 ARGYLE STREET, NKIL 6006, 6035 R.P., 6036 R.P., TITLE: ALUMINIUM WINDOWS AT PRECAST FACADE SHOPDRAWING SUBMISSION	DATE OF ISSUE							SUBMISSION STATE (FOR B.D / A.S.D)			SUBMISSION STATE (FOR CLIENT / CONSULTANT)			SUBMISSION STATE (FOR ARCHITECT)			FABRICATION / CONSTRUCTION STATE								
	ISSUE	1	2	3	4	5	6				AP - APPROVED			AP - APPROVED			AP - APPROVED			ISSUE TO CHINA OFFICE		ISSUE TO SITE		ISSUE TO SUB-CONTRACTOR	
	DAY	15	9	14	4	5	23				AC - APPROVED SUB. TO CONDITION			AC - APPROVED SUB. TO CONDITION			AC - APPROVED SUB. TO CONDITION								
	MONTH	8	12	1	2	3	3				NA - NOT APPROVED			NA - NOT APPROVED			NA - NOT APPROVED								
	YEAR	20	20	21	21	21	21																		
DRAWING TITLE	DWG. NO.	REVISIONS							COMMENT DATE	REV.	STATE	COMMENT DATE	REV.	STATE	COMMENT DATE	REV.	STATE	REV.	DATE	REV.	DATE	REV.	DATE		
DETAIL FOR Plenum Box	J852-SD-PB-5008		A	B	B	B	B																		
DETAIL FOR Plenum Box	J852-SD-PB-5009		-	-	-	-	-																		
DETAIL FOR Plenum Box	J852-SD-PB-5010		-	-	-	-	-																		
DETAIL FOR Plenum Box	J852-SD-PB-5011		-	-	-	-	-																		
DETAIL FOR Plenum Box	J852-SD-PB-5012		-	-	-	-	-																		
DETAIL FOR Plenum Box	J852-SD-PB-5013		-	A	A	A	A																		
DETAIL FOR Plenum Box	J852-SD-PB-5014		-	-	-	-	-																		
DETAIL FOR Plenum Box	J852-SD-PB-6001		-	A	A	A	A																		
DETAIL FOR Plenum Box	J852-SD-PB-6001a		-	-	-	-	A																		
DETAIL FOR Plenum Box	J852-SD-PB-6001b		-	-	-	A	A																		
DETAIL FOR Plenum Box	J852-SD-PB-6001c		-	-	-	-	-																		
DETAIL FOR Plenum Box	J852-SD-PB-6002		-	A	A	A	A																		
DETAIL FOR Plenum Box	J852-SD-PB-6003		-	A	A	A	A																		
DETAIL FOR Plenum Box	J852-SD-PB-6004		-	A	A	A	A																		
DETAIL FOR Plenum Box	J852-SD-PB-6005		-	A	A	A	A																		
DETAIL FOR Plenum Box	J852-SD-PB-6006		-	A	A	A	A																		
DETAIL FOR Plenum Box	J852-SD-PB-6007		-	-	-	-	-																		

IN-HOUSE DESIGN CHECKER

美特鋁質有限公司
MIDI ALUMINIUM FABRICATOR LTD.
 Units 6-8, Sunray Industrial Centre, 1/F
 610 Cha Kwo Ling Road, Kowloon
 Tel:23489211-4 Fax:(852)27727666

DWG NO. : J852-SD-PB-0003
REV. : -

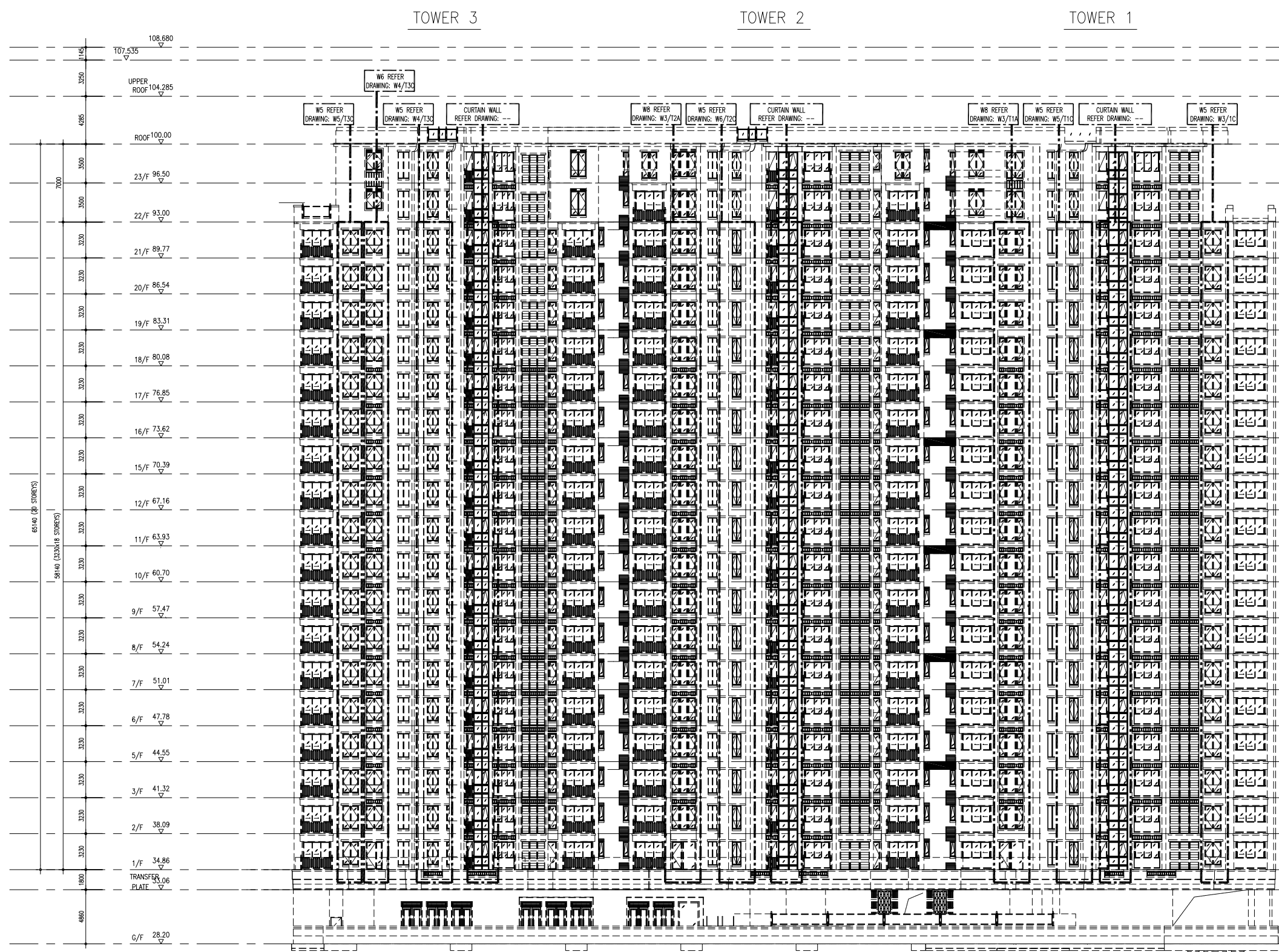
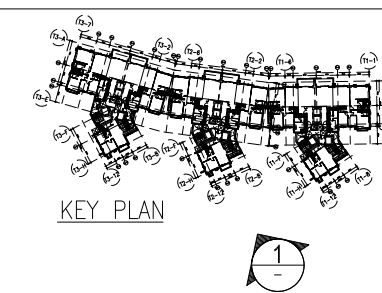

1 ELEVATION
SCALE 1:200

B.D. REF :

CLIENT :

ARCHITECT :

AGC
DESIGN LTD

MAIN CONTRACTOR :

Gammon

STRUCTURAL ENGINEER :

ARUP

FAÇADE CONSULTANT:

MEINHARDT

NOTE :

1. ALL DIMENSIONS ARE IN mm.
2. ALL ELEVATIONS ARE VIEWED FROM OUTSIDE.
3. ALL DIMENSIONS TO BE VERIFIED ON SITE BEFORE FABRICATION.

LEGEND :

(X1) — DETAIL MARK NO.
(X001) — REFER SHEET NO.

1. F.F.L. -- FINISHED FLOOR LEVEL
2. S.F.L. -- STRUCTURAL FLOOR LEVEL
3. (R) -- REVERSED DETAIL

NO.	DATE	REVISED	BY

JOB NO. : J-852

PROJECT : PROPOSED RESIDENTIAL DEVELOPMENT AT 139 - 147 ARGYLE STREET, NKIL 6005, 6035 R.P., 6036 R.P., 6037 R.P. & 6038 R.P.

TITLE : BUILDING ELEVATION FOR TOWER 1, 2 & 3

DATE : 12-Dec-2019 SCALE : 1:200

DRAWN BY : MN CHECKED BY : DW

美特鋁質有限公司
MIDI ALUMINIUM FABRICATOR LTD.
Units 6-8, Sunray Industrial Centre, 1/F
610 Cha Kwo Ling Road, Kowloon
Tel:23489211-4 Fax:(852)2727666

DWG NO. : J852-SD-PB-2001 REV. : -

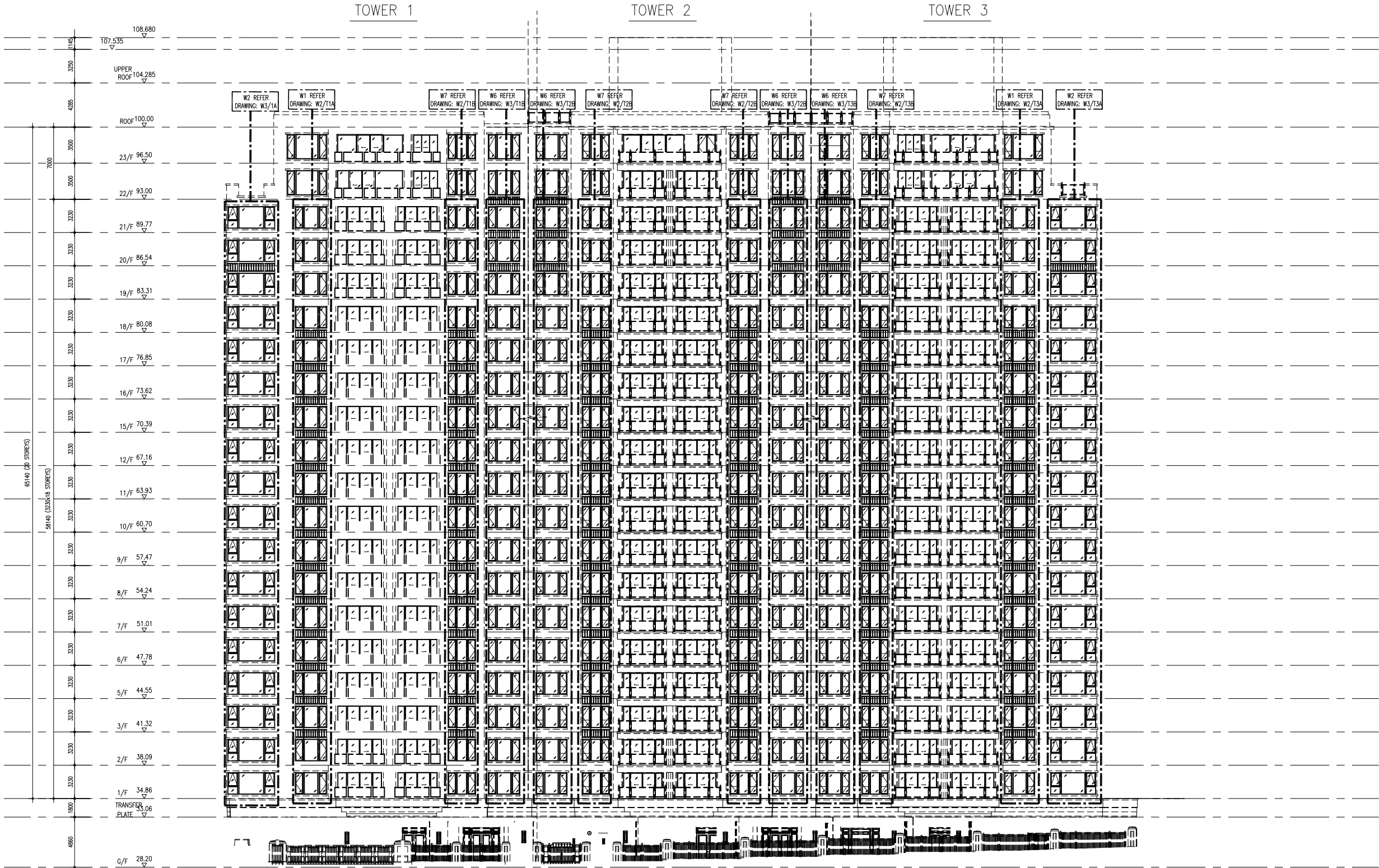
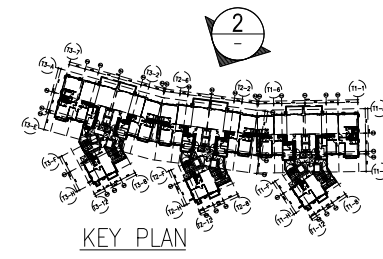

2 ELEVATION
SCALE 1:200
(4/F, 13/F & 14/F EXCLUDED)

B.D. REF :

CLIENT :

ARCHITECT :
AGC DESIGN LTD
101, 102, 103, 104, 105, 106, 107, 108, 109, 110, 111, 112, 113, 114, 115, 116, 117, 118, 119, 120, 121, 122, 123, 124, 125, 126, 127, 128, 129, 130, 131, 132, 133, 134, 135, 136, 137, 138, 139, 140, 141, 142, 143, 144, 145, 146, 147, 148, 149, 150, 151, 152, 153, 154, 155, 156, 157, 158, 159, 160, 161, 162, 163, 164, 165, 166, 167, 168, 169, 170, 171, 172, 173, 174, 175, 176, 177, 178, 179, 180, 181, 182, 183, 184, 185, 186, 187, 188, 189, 190, 191, 192, 193, 194, 195, 196, 197, 198, 199, 200, 201, 202, 203, 204, 205, 206, 207, 208, 209, 210, 211, 212, 213, 214, 215, 216, 217, 218, 219, 220, 221, 222, 223, 224, 225, 226, 227, 228, 229, 230, 231, 232, 233, 234, 235, 236, 237, 238, 239, 240, 241, 242, 243, 244, 245, 246, 247, 248, 249, 250, 251, 252, 253, 254, 255, 256, 257, 258, 259, 260, 261, 262, 263, 264, 265, 266, 267, 268, 269, 270, 271, 272, 273, 274, 275, 276, 277, 278, 279, 280, 281, 282, 283, 284, 285, 286, 287, 288, 289, 290, 291, 292, 293, 294, 295, 296, 297, 298, 299, 300, 301, 302, 303, 304, 305, 306, 307, 308, 309, 310, 311, 312, 313, 314, 315, 316, 317, 318, 319, 320, 321, 322, 323, 324, 325, 326, 327, 328, 329, 330, 331, 332, 333, 334, 335, 336, 337, 338, 339, 340, 341, 342, 343, 344, 345, 346, 347, 348, 349, 350, 351, 352, 353, 354, 355, 356, 357, 358, 359, 360, 361, 362, 363, 364, 365, 366, 367, 368, 369, 370, 371, 372, 373, 374, 375, 376, 377, 378, 379, 380, 381, 382, 383, 384, 385, 386, 387, 388, 389, 390, 391, 392, 393, 394, 395, 396, 397, 398, 399, 400, 401, 402, 403, 404, 405, 406, 407, 408, 409, 410, 411, 412, 413, 414, 415, 416, 417, 418, 419, 420, 421, 422, 423, 424, 425, 426, 427, 428, 429, 430, 431, 432, 433, 434, 435, 436, 437, 438, 439, 440, 441, 442, 443, 444, 445, 446, 447, 448, 449, 450, 451, 452, 453, 454, 455, 456, 457, 458, 459, 460, 461, 462, 463, 464, 465, 466, 467, 468, 469, 470, 471, 472, 473, 474, 475, 476, 477, 478, 479, 480, 481, 482, 483, 484, 485, 486, 487, 488, 489, 490, 491, 492, 493, 494, 495, 496, 497, 498, 499, 500, 501, 502, 503, 504, 505, 506, 507, 508, 509, 510, 511, 512, 513, 514, 515, 516, 517, 518, 519, 520, 521, 522, 523, 524, 525, 526, 527, 528, 529, 530, 531, 532, 533, 534, 535, 536, 537, 538, 539, 540, 541, 542, 543, 544, 545, 546, 547, 548, 549, 550, 551, 552, 553, 554, 555, 556, 557, 558, 559, 560, 561, 562, 563, 564, 565, 566, 567, 568, 569, 570, 571, 572, 573, 574, 575, 576, 577, 578, 579, 580, 581, 582, 583, 584, 585, 586, 587, 588, 589, 590, 591, 592, 593, 594, 595, 596, 597, 598, 599, 600, 601, 602, 603, 604, 605, 606, 607, 608, 609, 610, 611, 612, 613, 614, 615, 616, 617, 618, 619, 620, 621, 622, 623, 624, 625, 626, 627, 628, 629, 630, 631, 632, 633, 634, 635, 636, 637, 638, 639, 640, 641, 642, 643, 644, 645, 646, 647, 648, 649, 650, 651, 652, 653, 654, 655, 656, 657, 658, 659, 660, 661, 662, 663, 664, 665, 666, 667, 668, 669, 670, 671, 672, 673, 674, 675, 676, 677, 678, 679, 680, 681, 682, 683, 684, 685, 686, 687, 688, 689, 690, 691, 692, 693, 694, 695, 696, 697, 698, 699, 700, 701, 702, 703, 704, 705, 706, 707, 708, 709, 710, 711, 712, 713, 714, 715, 716, 717, 718, 719, 720, 721, 722, 723, 724, 725, 726, 727, 728, 729, 730, 731, 732, 733, 734, 735, 736, 737, 738, 739, 740, 741, 742, 743, 744, 745, 746, 747, 748, 749, 750, 751, 752, 753, 754, 755, 756, 757, 758, 759, 760, 761, 762, 763, 764, 765, 766, 767, 768, 769, 770, 771, 772, 773, 774, 775, 776, 777, 778, 779, 780, 781, 782, 783, 784, 785, 786, 787, 788, 789, 790, 791, 792, 793, 794, 795, 796, 797, 798, 799, 800, 801, 802, 803, 804, 805, 806, 807, 808, 809, 810, 811, 812, 813, 814, 815, 816, 817, 818, 819, 820, 821, 822, 823, 824, 825, 826, 827, 828, 829, 830, 831, 832, 833, 834, 835, 836, 837, 838, 839, 840, 841, 842, 843, 844, 845, 846, 847, 848, 849, 850, 851, 852, 853, 854, 855, 856, 857, 858, 859, 860, 861, 862, 863, 864, 865, 866, 867, 868, 869, 870, 871, 872, 873, 874, 875, 876, 877, 878, 879, 880, 881, 882, 883, 884, 885, 886, 887, 888, 889, 890, 891, 892, 893, 894, 895, 896, 897, 898, 899, 900, 901, 902, 903, 904, 905, 906, 907, 908, 909, 910, 911, 912, 913, 914, 915, 916, 917, 918, 919, 920, 921, 922, 923, 924, 925, 926, 927, 928, 929, 930, 931, 932, 933, 934, 935, 936, 937, 938, 939, 940, 941, 942, 943, 944, 945, 946, 947, 948, 949, 950, 951, 952, 953, 954, 955, 956, 957, 958, 959, 960, 961, 962, 963, 964, 965, 966, 967, 968, 969, 970, 971, 972, 973, 974, 975, 976, 977, 978, 979, 980, 981, 982, 983, 984, 985, 986, 987, 988, 989, 990, 991, 992, 993, 994, 995, 996, 997, 998, 999, 1000

NO. DATE REVISION BY

JOB NO. : J-852
PROJECT : PROPOSED RESIDENTIAL DEVELOPMENT AT 139 - 147 ARGYLE STREET, NKIL 6005, 6035 R.P., 6036 R.P., 6037 R.P. & 6038 R.P.
TITLE : BUILDING ELEVATION FOR TOWER 1, 2 & 3
DATE : 12-Dec-2019 SCALE : 1:200
DRAWN BY : MN CHECKED BY : DW
美特鋁質有限公司
MIDI ALUMINIUM FABRICATOR LTD.
Units 6-8, Sunray Industrial Centre, 1/F
610 Cha Kwo Ling Road, Kowloon
Tel:23489211-4 Fax:(852)2727666
DWG NO. : J852-SD-PB-2002 REV. : -

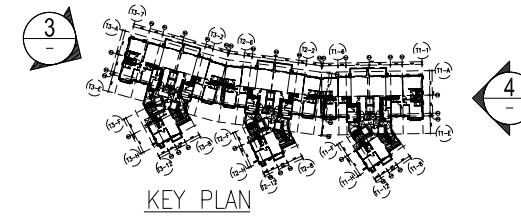

TOWER 3

TOWER 1

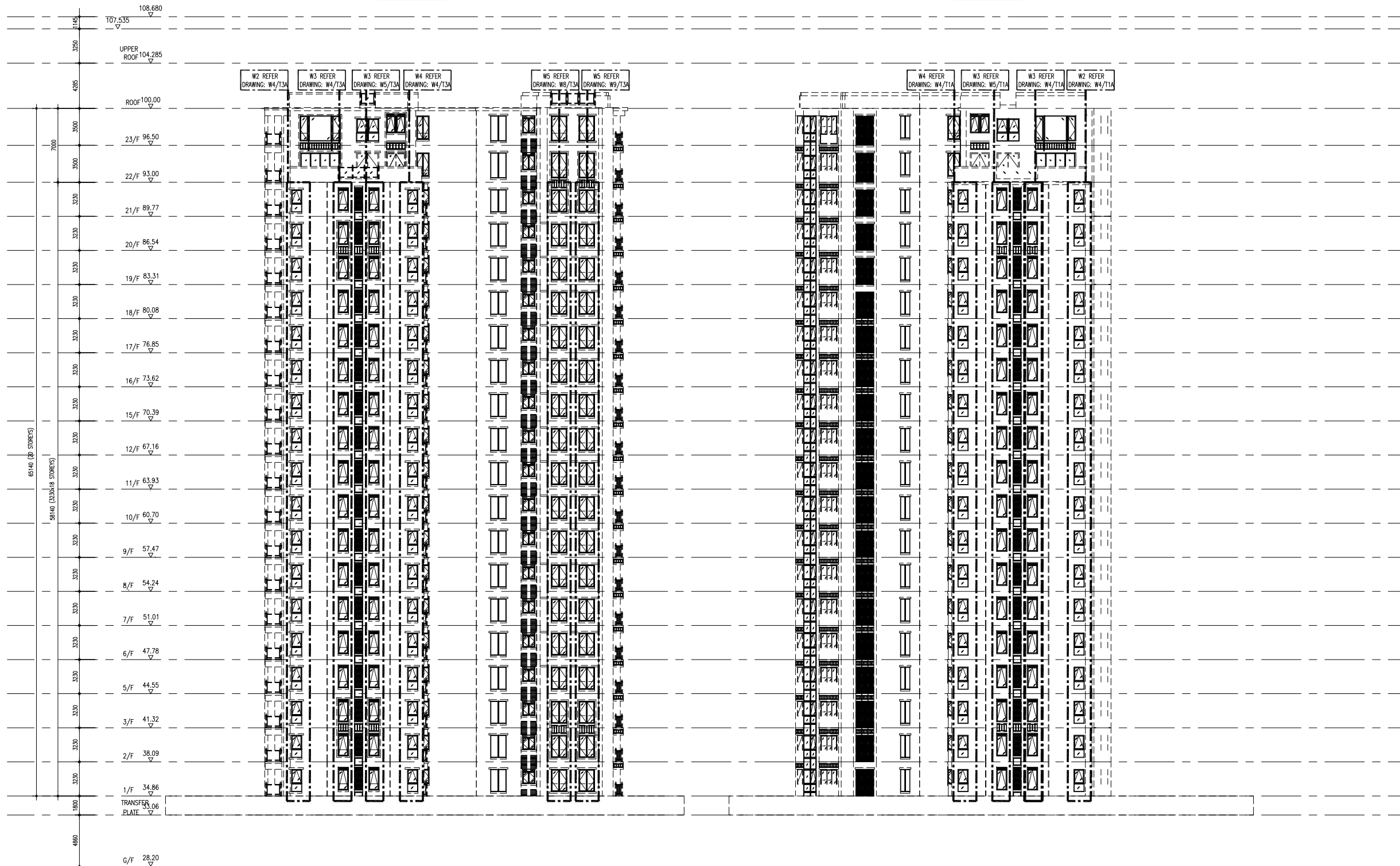

3 ELEVATION

SCALE 1:200
(4/F, 13/F & 14/F EXCLUDED)

4 ELEVATION

SCALE 1:200
(4/F, 13/F & 14/F EXCLUDED)

B.D. REF :

CLIENT :

ARCHITECT :
AGC DESIGN LTD

MAIN CONTRACTOR :
Gammon

STRUCTURAL ENGINEER :
ARUP

FACADE CONSULTANT:
MEINHARDT

NOTE :
1. ALL DIMENSIONS ARE IN mm.
2. ALL ELEVATIONS ARE VIEWED FROM OUTSIDE.
3. ALL DIMENSIONS TO BE VERIFIED ON SITE BEFORE FABRICATION.

LEGEND :
 (X1) --- DETAIL MARK NO.
 (X001) --- REFER SHEET NO.
 1. F.F.L. --- FINISHED FLOOR LEVEL
 2. S.F.L. --- STRUCTURAL FLOOR LEVEL
 3. (R) --- REVERSED DETAIL

NO.	DATE	REVISED	BY

JOB NO. : J-852
 PROJECT : PROPOSED RESIDENTIAL DEVELOPMENT AT 139 - 147 ARGYLE STREET, NKIL 6005, 6035 R.P., 6036 R.P., 6037 R.P. & 6038 R.P.

TITLE : BUILDING ELEVATION FOR TOWER 1, 2 & 3

DATE : 12-Dec-2019 SCALE : 1:200

DRAWN BY : MN CHECKED BY : DW

美特鋁質有限公司
MIDI ALUMINIUM FABRICATOR LTD.
 Units 6-8, Sunray Industrial Centre, 1/F
 610 Cha Kwo Ling Road, Kowloon
 Tel:23489211-4 Fax:(852)2727666

DWG NO. : J852-SD-PB-2003 REV. : -

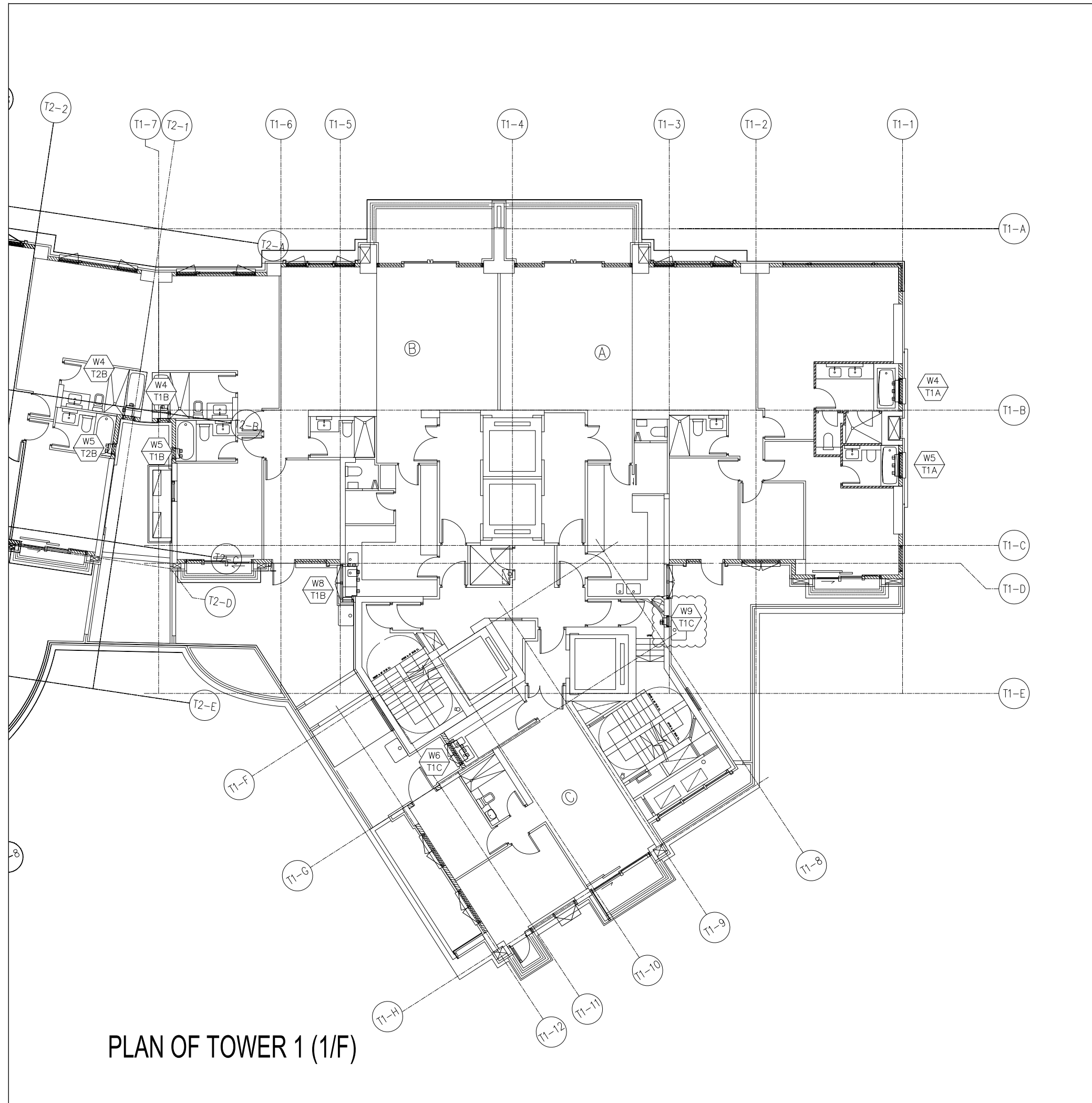

PLAN OF TOWER 1 (1/F)

B.D. REF :

CLIENT :

ARCHITECT :
AGC DESIGN LTD
 161, 162, 163, 164, 165, 166, 167, 168, 169, 170, 171, 172, 173, 174, 175, 176, 177, 178, 179, 180, 181, 182, 183, 184, 185, 186, 187, 188, 189, 190, 191, 192, 193, 194, 195, 196, 197, 198, 199, 200, 201, 202, 203, 204, 205, 206, 207, 208, 209, 210, 211, 212, 213, 214, 215, 216, 217, 218, 219, 220, 221, 222, 223, 224, 225, 226, 227, 228, 229, 230, 231, 232, 233, 234, 235, 236, 237, 238, 239, 240, 241, 242, 243, 244, 245, 246, 247, 248, 249, 250, 251, 252, 253, 254, 255, 256, 257, 258, 259, 260, 261, 262, 263, 264, 265, 266, 267, 268, 269, 270, 271, 272, 273, 274, 275, 276, 277, 278, 279, 280, 281, 282, 283, 284, 285, 286, 287, 288, 289, 290, 291, 292, 293, 294, 295, 296, 297, 298, 299, 300, 301, 302, 303, 304, 305, 306, 307, 308, 309, 310, 311, 312, 313, 314, 315, 316, 317, 318, 319, 320, 321, 322, 323, 324, 325, 326, 327, 328, 329, 330, 331, 332, 333, 334, 335, 336, 337, 338, 339, 340, 341, 342, 343, 344, 345, 346, 347, 348, 349, 350, 351, 352, 353, 354, 355, 356, 357, 358, 359, 360, 361, 362, 363, 364, 365, 366, 367, 368, 369, 370, 371, 372, 373, 374, 375, 376, 377, 378, 379, 380, 381, 382, 383, 384, 385, 386, 387, 388, 389, 390, 391, 392, 393, 394, 395, 396, 397, 398, 399, 400, 401, 402, 403, 404, 405, 406, 407, 408, 409, 410, 411, 412, 413, 414, 415, 416, 417, 418, 419, 420, 421, 422, 423, 424, 425, 426, 427, 428, 429, 430, 431, 432, 433, 434, 435, 436, 437, 438, 439, 440, 441, 442, 443, 444, 445, 446, 447, 448, 449, 450, 451, 452, 453, 454, 455, 456, 457, 458, 459, 460, 461, 462, 463, 464, 465, 466, 467, 468, 469, 470, 471, 472, 473, 474, 475, 476, 477, 478, 479, 480, 481, 482, 483, 484, 485, 486, 487, 488, 489, 490, 491, 492, 493, 494, 495, 496, 497, 498, 499, 500, 501, 502, 503, 504, 505, 506, 507, 508, 509, 510, 511, 512, 513, 514, 515, 516, 517, 518, 519, 520, 521, 522, 523, 524, 525, 526, 527, 528, 529, 530, 531, 532, 533, 534, 535, 536, 537, 538, 539, 540, 541, 542, 543, 544, 545, 546, 547, 548, 549, 550, 551, 552, 553, 554, 555, 556, 557, 558, 559, 560, 561, 562, 563, 564, 565, 566, 567, 568, 569, 570, 571, 572, 573, 574, 575, 576, 577, 578, 579, 580, 581, 582, 583, 584, 585, 586, 587, 588, 589, 590, 591, 592, 593, 594, 595, 596, 597, 598, 599, 600, 601, 602, 603, 604, 605, 606, 607, 608, 609, 610, 611, 612, 613, 614, 615, 616, 617, 618, 619, 620, 621, 622, 623, 624, 625, 626, 627, 628, 629, 630, 631, 632, 633, 634, 635, 636, 637, 638, 639, 640, 641, 642, 643, 644, 645, 646, 647, 648, 649, 650, 651, 652, 653, 654, 655, 656, 657, 658, 659, 660, 661, 662, 663, 664, 665, 666, 667, 668, 669, 670, 671, 672, 673, 674, 675, 676, 677, 678, 679, 680, 681, 682, 683, 684, 685, 686, 687, 688, 689, 690, 691, 692, 693, 694, 695, 696, 697, 698, 699, 700, 701, 702, 703, 704, 705, 706, 707, 708, 709, 710, 711, 712, 713, 714, 715, 716, 717, 718, 719, 720, 721, 722, 723, 724, 725, 726, 727, 728, 729, 730, 731, 732, 733, 734, 735, 736, 737, 738, 739, 740, 741, 742, 743, 744, 745, 746, 747, 748, 749, 750, 751, 752, 753, 754, 755, 756, 757, 758, 759, 760, 761, 762, 763, 764, 765, 766, 767, 768, 769, 770, 771, 772, 773, 774, 775, 776, 777, 778, 779, 780, 781, 782, 783, 784, 785, 786, 787, 788, 789, 790, 791, 792, 793, 794, 795, 796, 797, 798, 799, 800, 801, 802, 803, 804, 805, 806, 807, 808, 809, 810, 811, 812, 813, 814, 815, 816, 817, 818, 819, 820, 821, 822, 823, 824, 825, 826, 827, 828, 829, 830, 831, 832, 833, 834, 835, 836, 837, 838, 839, 840, 841, 842, 843, 844, 845, 846, 847, 848, 849, 850, 851, 852, 853, 854, 855, 856, 857, 858, 859, 860, 861, 862, 863, 864, 865, 866, 867, 868, 869, 870, 871, 872, 873, 874, 875, 876, 877, 878, 879, 880, 881, 882, 883, 884, 885, 886, 887, 888, 889, 890, 891, 892, 893, 894, 895, 896, 897, 898, 899, 900, 901, 902, 903, 904, 905, 906, 907, 908, 909, 910, 911, 912, 913, 914, 915, 916, 917, 918, 919, 920, 921, 922, 923, 924, 925, 926, 927, 928, 929, 930, 931, 932, 933, 934, 935, 936, 937, 938, 939, 940, 941, 942, 943, 944, 945, 946, 947, 948, 949, 950, 951, 952, 953, 954, 955, 956, 957, 958, 959, 960, 961, 962, 963, 964, 965, 966, 967, 968, 969, 970, 971, 972, 973, 974, 975, 976, 977, 978, 979, 980, 981, 982, 983, 984, 985, 986, 987, 988, 989, 990, 991, 992, 993, 994, 995, 996, 997, 998, 999, 1000

MAIN CONTRACTOR :
Gammon

STRUCTURAL ENGINEER :
ARUP

FAÇADE CONSULTANT:
MEINHARDT

NOTE :
 1. ALL DIMENSIONS ARE IN mm.
 2. ALL ELEVATIONS ARE VIEWED FROM OUTSIDE.
 3. ALL DIMENSIONS TO BE VERIFIED ON SITE BEFORE FABRICATION.

LEGEND :
 x1 — DETAIL MARK NO.
 x001 — REFER SHEET NO.
 1. F.F.L. -- FINISHED FLOOR LEVEL
 2. S.F.L. -- STRUCTURAL FLOOR LEVEL
 3. (R) -- REVERSED DETAIL

B	08/01/2021	REVISION SUBJECT TO ARCH.COMMENT	Ivan
A	07/11/2020	REVISION SUBJECT TO ARCH.COMMENT	Ivan
NO.	DATE	REVISION	BY

JOB NO. : J-852
 PROJECT :
 PROPOSED RESIDENTIAL DEVELOPMENT
 AT 139 - 147 ARGYLE STREET,
 NKIL 6005, 6035 R.P., 6036 R.P.,
 6037 R.P. & 6038 R.P.

TITLE :
 PART PLAN OF
 TOWER 1 (1/F)

DATE : 12-Dec-2019 SCALE : 1:150

DRAWN BY : MN CHECKED BY : DW

美特鋁質有限公司
MIDI ALUMINIUM FABRICATOR LTD.
 Units 6-8, Sunray Industrial Centre, 1/F
 610 Cha Kwo Ling Road, Kowloon
 Tel: 23489211-4 Fax: (852)2727666

DWG NO. : J852-SD-PB-3001 REV. : B

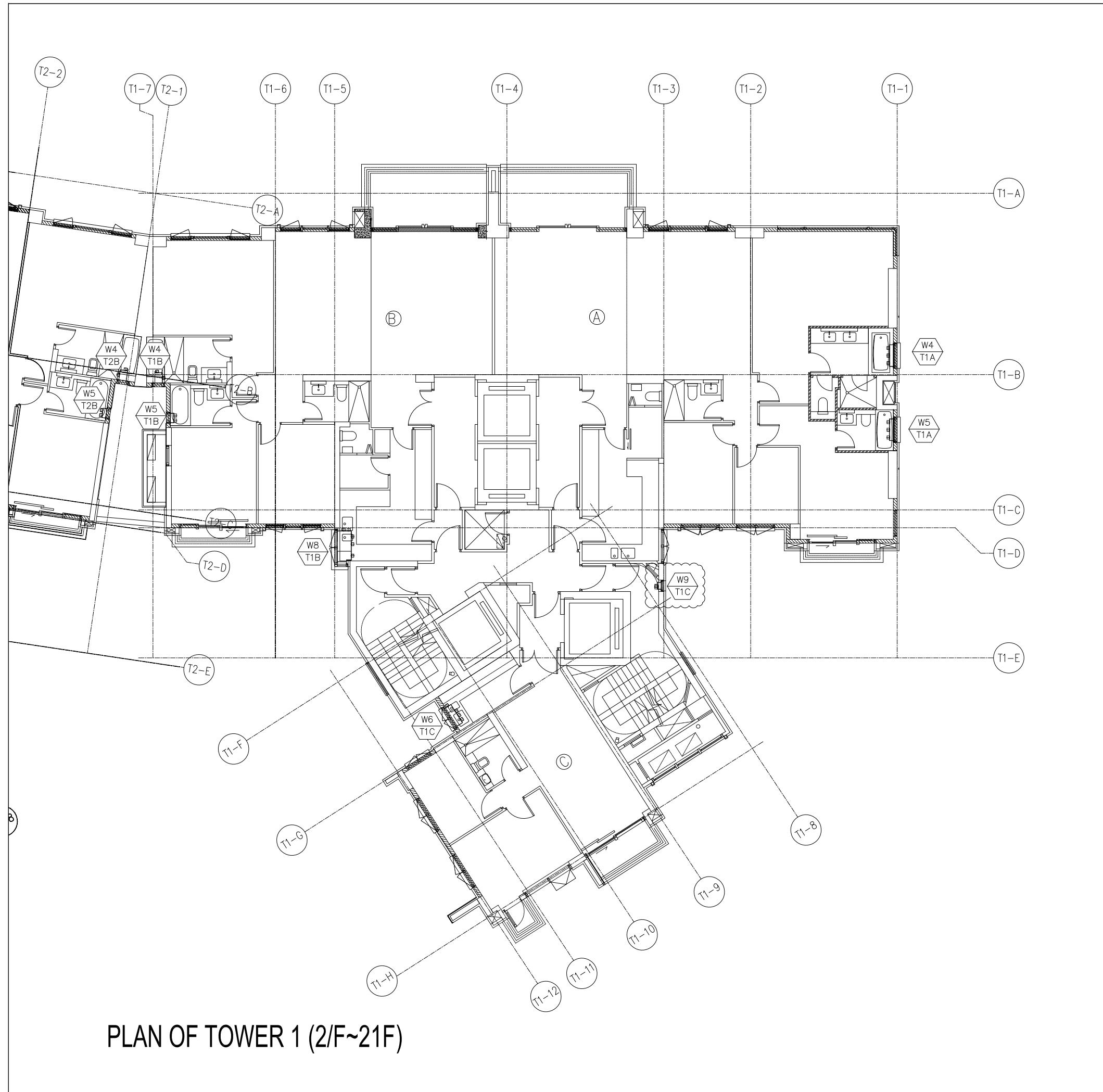

PLAN OF TOWER 1 (2/F~21/F)

B.D. REF :

CLIENT :

ARCHITECT :
AGC DESIGN LTD
 101, 102, 103, 104, 105, 106, 107, 108, 109, 110, 111, 112, 113, 114, 115, 116, 117, 118, 119, 120, 121, 122, 123, 124, 125, 126, 127, 128, 129, 130, 131, 132, 133, 134, 135, 136, 137, 138, 139, 140, 141, 142, 143, 144, 145, 146, 147, 148, 149, 150, 151, 152, 153, 154, 155, 156, 157, 158, 159, 160, 161, 162, 163, 164, 165, 166, 167, 168, 169, 170, 171, 172, 173, 174, 175, 176, 177, 178, 179, 180, 181, 182, 183, 184, 185, 186, 187, 188, 189, 190, 191, 192, 193, 194, 195, 196, 197, 198, 199, 200, 201, 202, 203, 204, 205, 206, 207, 208, 209, 210, 211, 212, 213, 214, 215, 216, 217, 218, 219, 220, 221, 222, 223, 224, 225, 226, 227, 228, 229, 230, 231, 232, 233, 234, 235, 236, 237, 238, 239, 240, 241, 242, 243, 244, 245, 246, 247, 248, 249, 250, 251, 252, 253, 254, 255, 256, 257, 258, 259, 260, 261, 262, 263, 264, 265, 266, 267, 268, 269, 270, 271, 272, 273, 274, 275, 276, 277, 278, 279, 280, 281, 282, 283, 284, 285, 286, 287, 288, 289, 290, 291, 292, 293, 294, 295, 296, 297, 298, 299, 300, 301, 302, 303, 304, 305, 306, 307, 308, 309, 310, 311, 312, 313, 314, 315, 316, 317, 318, 319, 320, 321, 322, 323, 324, 325, 326, 327, 328, 329, 330, 331, 332, 333, 334, 335, 336, 337, 338, 339, 340, 341, 342, 343, 344, 345, 346, 347, 348, 349, 350, 351, 352, 353, 354, 355, 356, 357, 358, 359, 360, 361, 362, 363, 364, 365, 366, 367, 368, 369, 370, 371, 372, 373, 374, 375, 376, 377, 378, 379, 380, 381, 382, 383, 384, 385, 386, 387, 388, 389, 390, 391, 392, 393, 394, 395, 396, 397, 398, 399, 400, 401, 402, 403, 404, 405, 406, 407, 408, 409, 410, 411, 412, 413, 414, 415, 416, 417, 418, 419, 420, 421, 422, 423, 424, 425, 426, 427, 428, 429, 430, 431, 432, 433, 434, 435, 436, 437, 438, 439, 440, 441, 442, 443, 444, 445, 446, 447, 448, 449, 450, 451, 452, 453, 454, 455, 456, 457, 458, 459, 460, 461, 462, 463, 464, 465, 466, 467, 468, 469, 470, 471, 472, 473, 474, 475, 476, 477, 478, 479, 480, 481, 482, 483, 484, 485, 486, 487, 488, 489, 490, 491, 492, 493, 494, 495, 496, 497, 498, 499, 500, 501, 502, 503, 504, 505, 506, 507, 508, 509, 510, 511, 512, 513, 514, 515, 516, 517, 518, 519, 520, 521, 522, 523, 524, 525, 526, 527, 528, 529, 530, 531, 532, 533, 534, 535, 536, 537, 538, 539, 540, 541, 542, 543, 544, 545, 546, 547, 548, 549, 550, 551, 552, 553, 554, 555, 556, 557, 558, 559, 560, 561, 562, 563, 564, 565, 566, 567, 568, 569, 570, 571, 572, 573, 574, 575, 576, 577, 578, 579, 580, 581, 582, 583, 584, 585, 586, 587, 588, 589, 590, 591, 592, 593, 594, 595, 596, 597, 598, 599, 600, 601, 602, 603, 604, 605, 606, 607, 608, 609, 610, 611, 612, 613, 614, 615, 616, 617, 618, 619, 620, 621, 622, 623, 624, 625, 626, 627, 628, 629, 630, 631, 632, 633, 634, 635, 636, 637, 638, 639, 640, 641, 642, 643, 644, 645, 646, 647, 648, 649, 650, 651, 652, 653, 654, 655, 656, 657, 658, 659, 660, 661, 662, 663, 664, 665, 666, 667, 668, 669, 670, 671, 672, 673, 674, 675, 676, 677, 678, 679, 680, 681, 682, 683, 684, 685, 686, 687, 688, 689, 690, 691, 692, 693, 694, 695, 696, 697, 698, 699, 700, 701, 702, 703, 704, 705, 706, 707, 708, 709, 710, 711, 712, 713, 714, 715, 716, 717, 718, 719, 720, 721, 722, 723, 724, 725, 726, 727, 728, 729, 730, 731, 732, 733, 734, 735, 736, 737, 738, 739, 740, 741, 742, 743, 744, 745, 746, 747, 748, 749, 750, 751, 752, 753, 754, 755, 756, 757, 758, 759, 760, 761, 762, 763, 764, 765, 766, 767, 768, 769, 770, 771, 772, 773, 774, 775, 776, 777, 778, 779, 780, 781, 782, 783, 784, 785, 786, 787, 788, 789, 790, 791, 792, 793, 794, 795, 796, 797, 798, 799, 800, 801, 802, 803, 804, 805, 806, 807, 808, 809, 810, 811, 812, 813, 814, 815, 816, 817, 818, 819, 820, 821, 822, 823, 824, 825, 826, 827, 828, 829, 830, 831, 832, 833, 834, 835, 836, 837, 838, 839, 840, 841, 842, 843, 844, 845, 846, 847, 848, 849, 850, 851, 852, 853, 854, 855, 856, 857, 858, 859, 860, 861, 862, 863, 864, 865, 866, 867, 868, 869, 870, 871, 872, 873, 874, 875, 876, 877, 878, 879, 880, 881, 882, 883, 884, 885, 886, 887, 888, 889, 890, 891, 892, 893, 894, 895, 896, 897, 898, 899, 900, 901, 902, 903, 904, 905, 906, 907, 908, 909, 910, 911, 912, 913, 914, 915, 916, 917, 918, 919, 920, 921, 922, 923, 924, 925, 926, 927, 928, 929, 930, 931, 932, 933, 934, 935, 936, 937, 938, 939, 940, 941, 942, 943, 944, 945, 946, 947, 948, 949, 950, 951, 952, 953, 954, 955, 956, 957, 958, 959, 960, 961, 962, 963, 964, 965, 966, 967, 968, 969, 970, 971, 972, 973, 974, 975, 976, 977, 978, 979, 980, 981, 982, 983, 984, 985, 986, 987, 988, 989, 990, 991, 992, 993, 994, 995, 996, 997, 998, 999, 1000

MAIN CONTRACTOR :
Gammon

STRUCTURAL ENGINEER :
ARUP

FAÇADE CONSULTANT:
MEINHARDT

NOTE :
 1. ALL DIMENSIONS ARE IN mm.
 2. ALL ELEVATIONS ARE VIEWED FROM OUTSIDE.
 3. ALL DIMENSIONS TO BE VERIFIED ON SITE BEFORE FABRICATION.

LEGEND :
 x1 — DETAIL MARK NO.
 x001 — REFER SHEET NO.
 1. F.F.L. -- FINISHED FLOOR LEVEL
 2. S.F.L. -- STRUCTURAL FLOOR LEVEL
 3. (R) -- REVERSED DETAIL

B	08/01/2021	REVISION SUBJECT TO ARCH.COMMENT	Ivan
A	07/11/2020	REVISION SUBJECT TO ARCH.COMMENT	Ivan
NO.	DATE	REVISED	BY

JOB NO. : J-852
 PROJECT :
 PROPOSED RESIDENTIAL DEVELOPMENT
 AT 139 - 147 ARGYLE STREET,
 NKIL 6005, 6035 R.P., 6036 R.P.,
 6037 R.P. & 6038 R.P.

TITLE :
 PART PLAN OF
 TOWER 1 (2-21/F)

DATE : 12-Dec-2019 SCALE : 1:150
 DRAWN BY : MN CHECKED BY : DW

美特鋁質有限公司
MIDI ALUMINIUM FABRICATOR LTD.
 Units 6-8, Sunray Industrial Centre, 1/F
 610 Cha Kwo Ling Road, Kowloon
 Tel: 23489211-4 Fax: (852)27727666

DWG NO. : J852-SD-PB-3002 REV. : B

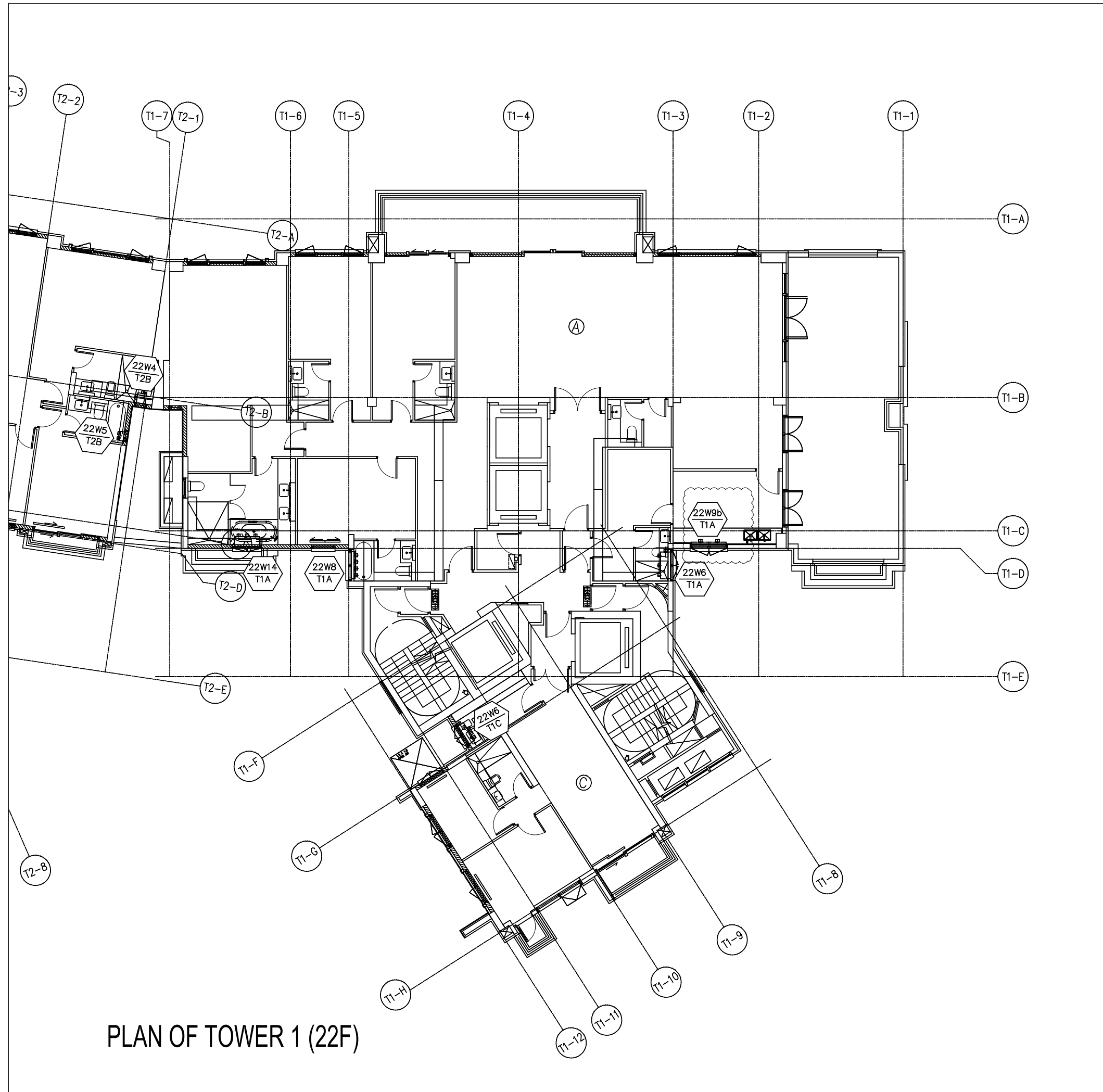

PLAN OF TOWER 1 (22F)

B.D. REF :

CLIENT :

ARCHITECT :
AGC DESIGN LTD
 181, 182, 183, 184, 185, 186, 187, 188, 189, 190, 191, 192, 193, 194, 195, 196, 197, 198, 199, 200, 201, 202, 203, 204, 205, 206, 207, 208, 209, 210, 211, 212, 213, 214, 215, 216, 217, 218, 219, 220, 221, 222, 223, 224, 225, 226, 227, 228, 229, 230, 231, 232, 233, 234, 235, 236, 237, 238, 239, 240, 241, 242, 243, 244, 245, 246, 247, 248, 249, 250, 251, 252, 253, 254, 255, 256, 257, 258, 259, 260, 261, 262, 263, 264, 265, 266, 267, 268, 269, 270, 271, 272, 273, 274, 275, 276, 277, 278, 279, 280, 281, 282, 283, 284, 285, 286, 287, 288, 289, 290, 291, 292, 293, 294, 295, 296, 297, 298, 299, 300, 301, 302, 303, 304, 305, 306, 307, 308, 309, 310, 311, 312, 313, 314, 315, 316, 317, 318, 319, 320, 321, 322, 323, 324, 325, 326, 327, 328, 329, 330, 331, 332, 333, 334, 335, 336, 337, 338, 339, 340, 341, 342, 343, 344, 345, 346, 347, 348, 349, 350, 351, 352, 353, 354, 355, 356, 357, 358, 359, 360, 361, 362, 363, 364, 365, 366, 367, 368, 369, 370, 371, 372, 373, 374, 375, 376, 377, 378, 379, 380, 381, 382, 383, 384, 385, 386, 387, 388, 389, 390, 391, 392, 393, 394, 395, 396, 397, 398, 399, 400, 401, 402, 403, 404, 405, 406, 407, 408, 409, 410, 411, 412, 413, 414, 415, 416, 417, 418, 419, 420, 421, 422, 423, 424, 425, 426, 427, 428, 429, 430, 431, 432, 433, 434, 435, 436, 437, 438, 439, 440, 441, 442, 443, 444, 445, 446, 447, 448, 449, 450, 451, 452, 453, 454, 455, 456, 457, 458, 459, 460, 461, 462, 463, 464, 465, 466, 467, 468, 469, 470, 471, 472, 473, 474, 475, 476, 477, 478, 479, 480, 481, 482, 483, 484, 485, 486, 487, 488, 489, 490, 491, 492, 493, 494, 495, 496, 497, 498, 499, 500, 501, 502, 503, 504, 505, 506, 507, 508, 509, 510, 511, 512, 513, 514, 515, 516, 517, 518, 519, 520, 521, 522, 523, 524, 525, 526, 527, 528, 529, 530, 531, 532, 533, 534, 535, 536, 537, 538, 539, 540, 541, 542, 543, 544, 545, 546, 547, 548, 549, 550, 551, 552, 553, 554, 555, 556, 557, 558, 559, 560, 561, 562, 563, 564, 565, 566, 567, 568, 569, 570, 571, 572, 573, 574, 575, 576, 577, 578, 579, 580, 581, 582, 583, 584, 585, 586, 587, 588, 589, 590, 591, 592, 593, 594, 595, 596, 597, 598, 599, 600, 601, 602, 603, 604, 605, 606, 607, 608, 609, 610, 611, 612, 613, 614, 615, 616, 617, 618, 619, 620, 621, 622, 623, 624, 625, 626, 627, 628, 629, 630, 631, 632, 633, 634, 635, 636, 637, 638, 639, 640, 641, 642, 643, 644, 645, 646, 647, 648, 649, 650, 651, 652, 653, 654, 655, 656, 657, 658, 659, 660, 661, 662, 663, 664, 665, 666, 667, 668, 669, 670, 671, 672, 673, 674, 675, 676, 677, 678, 679, 680, 681, 682, 683, 684, 685, 686, 687, 688, 689, 690, 691, 692, 693, 694, 695, 696, 697, 698, 699, 700, 701, 702, 703, 704, 705, 706, 707, 708, 709, 710, 711, 712, 713, 714, 715, 716, 717, 718, 719, 720, 721, 722, 723, 724, 725, 726, 727, 728, 729, 730, 731, 732, 733, 734, 735, 736, 737, 738, 739, 740, 741, 742, 743, 744, 745, 746, 747, 748, 749, 750, 751, 752, 753, 754, 755, 756, 757, 758, 759, 760, 761, 762, 763, 764, 765, 766, 767, 768, 769, 770, 771, 772, 773, 774, 775, 776, 777, 778, 779, 780, 781, 782, 783, 784, 785, 786, 787, 788, 789, 790, 791, 792, 793, 794, 795, 796, 797, 798, 799, 800, 801, 802, 803, 804, 805, 806, 807, 808, 809, 810, 811, 812, 813, 814, 815, 816, 817, 818, 819, 820, 821, 822, 823, 824, 825, 826, 827, 828, 829, 830, 831, 832, 833, 834, 835, 836, 837, 838, 839, 840, 841, 842, 843, 844, 845, 846, 847, 848, 849, 850, 851, 852, 853, 854, 855, 856, 857, 858, 859, 860, 861, 862, 863, 864, 865, 866, 867, 868, 869, 870, 871, 872, 873, 874, 875, 876, 877, 878, 879, 880, 881, 882, 883, 884, 885, 886, 887, 888, 889, 890, 891, 892, 893, 894, 895, 896, 897, 898, 899, 900, 901, 902, 903, 904, 905, 906, 907, 908, 909, 910, 911, 912, 913, 914, 915, 916, 917, 918, 919, 920, 921, 922, 923, 924, 925, 926, 927, 928, 929, 930, 931, 932, 933, 934, 935, 936, 937, 938, 939, 940, 941, 942, 943, 944, 945, 946, 947, 948, 949, 950, 951, 952, 953, 954, 955, 956, 957, 958, 959, 960, 961, 962, 963, 964, 965, 966, 967, 968, 969, 970, 971, 972, 973, 974, 975, 976, 977, 978, 979, 980, 981, 982, 983, 984, 985, 986, 987, 988, 989, 990, 991, 992, 993, 994, 995, 996, 997, 998, 999, 1000

MAIN CONTRACTOR :
Gammon

STRUCTURAL ENGINEER :
ARUP

FAÇADE CONSULTANT:
MEINHARDT

NOTE :
 1. ALL DIMENSIONS ARE IN mm.
 2. ALL ELEVATIONS ARE VIEWED FROM OUTSIDE.
 3. ALL DIMENSIONS TO BE VERIFIED ON SITE BEFORE FABRICATION.

LEGEND :
 x1 — DETAIL MARK NO.
 x001 — REFER SHEET NO.
 1. F.F.L. -- FINISHED FLOOR LEVEL
 2. S.F.L. -- STRUCTURAL FLOOR LEVEL
 3. (R) -- REVERSED DETAIL

B	08/01/2021	REVISION SUBJECT TO ARCH.COMMENT	Ivan
A	07/11/2020	REVISION SUBJECT TO ARCH.COMMENT	Ivan
NO.	DATE	REVISED	BY

JOB NO. : J-852
 PROJECT :
 PROPOSED RESIDENTIAL DEVELOPMENT
 AT 139 - 147 ARGYLE STREET,
 NKIL 6005, 6035 R.P., 6036 R.P.,
 6037 R.P. & 6038 R.P.

TITLE :
 PART PLAN OF
 TOWER 1 (22/F)

DATE : 12-Dec-2019 SCALE : 1:150

DRAWN BY : MN CHECKED BY : DW

美特鋁質有限公司
MIDI ALUMINIUM FABRICATOR LTD.
 Units 6-8, Sunray Industrial Centre, 1/F
 610 Cha Kwo Ling Road, Kowloon
 Tel: 23489211-4 Fax: (852)27727666

DWG NO. : J852-SD-PB-3003 REV. : B

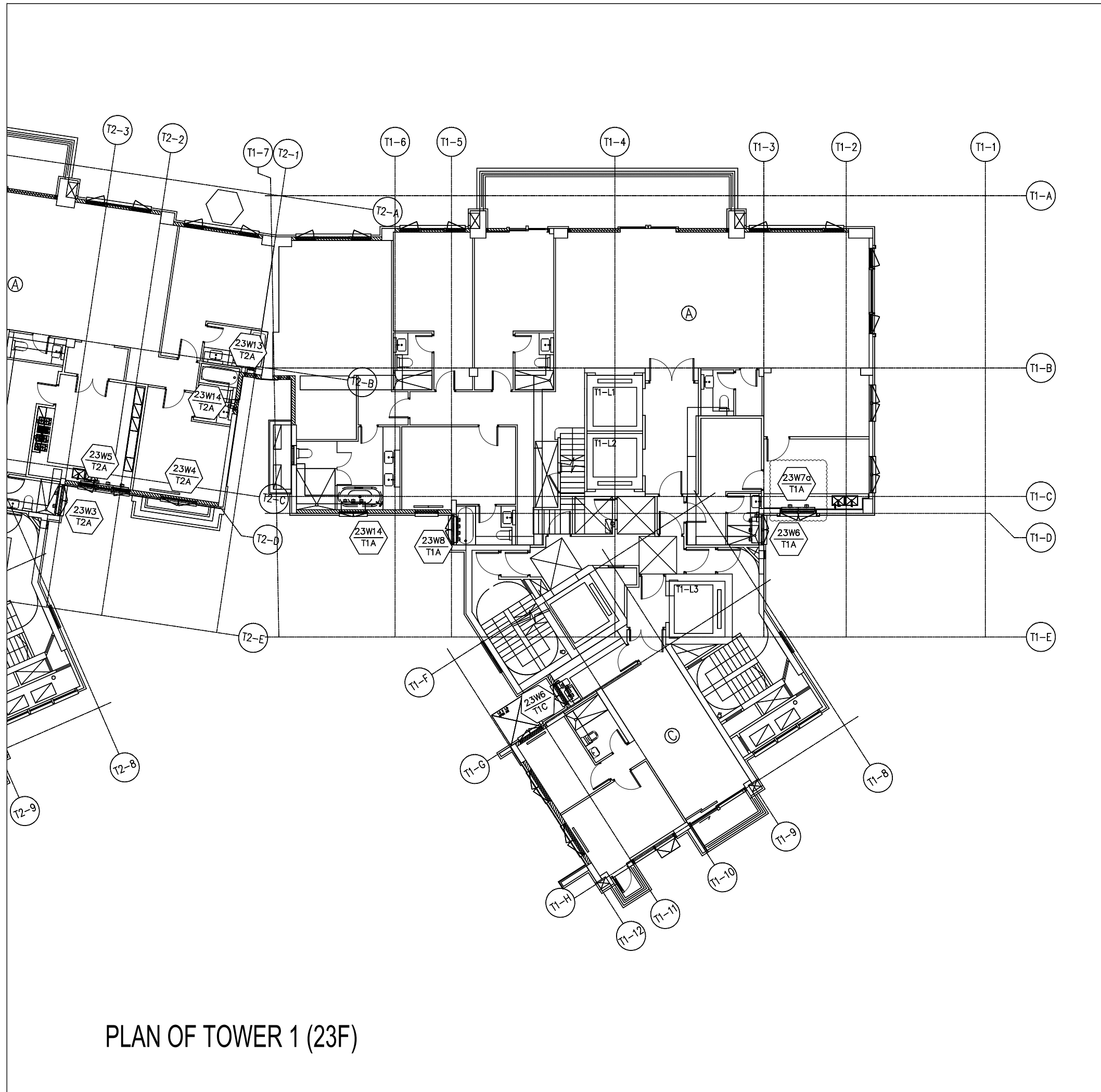

PLAN OF TOWER 1 (23F)

B.D. REF :

CLIENT :

ARCHITECT :
AGC DESIGN LTD
101, 102, 103, 104, 105, 106, 107, 108, 109, 110, 111, 112, 113, 114, 115, 116, 117, 118, 119, 120, 121, 122, 123, 124, 125, 126, 127, 128, 129, 130, 131, 132, 133, 134, 135, 136, 137, 138, 139, 140, 141, 142, 143, 144, 145, 146, 147, 148, 149, 150, 151, 152, 153, 154, 155, 156, 157, 158, 159, 160, 161, 162, 163, 164, 165, 166, 167, 168, 169, 170, 171, 172, 173, 174, 175, 176, 177, 178, 179, 180, 181, 182, 183, 184, 185, 186, 187, 188, 189, 190, 191, 192, 193, 194, 195, 196, 197, 198, 199, 200, 201, 202, 203, 204, 205, 206, 207, 208, 209, 210, 211, 212, 213, 214, 215, 216, 217, 218, 219, 220, 221, 222, 223, 224, 225, 226, 227, 228, 229, 230, 231, 232, 233, 234, 235, 236, 237, 238, 239, 240, 241, 242, 243, 244, 245, 246, 247, 248, 249, 250, 251, 252, 253, 254, 255, 256, 257, 258, 259, 260, 261, 262, 263, 264, 265, 266, 267, 268, 269, 270, 271, 272, 273, 274, 275, 276, 277, 278, 279, 280, 281, 282, 283, 284, 285, 286, 287, 288, 289, 290, 291, 292, 293, 294, 295, 296, 297, 298, 299, 300, 301, 302, 303, 304, 305, 306, 307, 308, 309, 310, 311, 312, 313, 314, 315, 316, 317, 318, 319, 320, 321, 322, 323, 324, 325, 326, 327, 328, 329, 330, 331, 332, 333, 334, 335, 336, 337, 338, 339, 340, 341, 342, 343, 344, 345, 346, 347, 348, 349, 350, 351, 352, 353, 354, 355, 356, 357, 358, 359, 360, 361, 362, 363, 364, 365, 366, 367, 368, 369, 370, 371, 372, 373, 374, 375, 376, 377, 378, 379, 380, 381, 382, 383, 384, 385, 386, 387, 388, 389, 390, 391, 392, 393, 394, 395, 396, 397, 398, 399, 400, 401, 402, 403, 404, 405, 406, 407, 408, 409, 410, 411, 412, 413, 414, 415, 416, 417, 418, 419, 420, 421, 422, 423, 424, 425, 426, 427, 428, 429, 430, 431, 432, 433, 434, 435, 436, 437, 438, 439, 440, 441, 442, 443, 444, 445, 446, 447, 448, 449, 450, 451, 452, 453, 454, 455, 456, 457, 458, 459, 460, 461, 462, 463, 464, 465, 466, 467, 468, 469, 470, 471, 472, 473, 474, 475, 476, 477, 478, 479, 480, 481, 482, 483, 484, 485, 486, 487, 488, 489, 490, 491, 492, 493, 494, 495, 496, 497, 498, 499, 500, 501, 502, 503, 504, 505, 506, 507, 508, 509, 510, 511, 512, 513, 514, 515, 516, 517, 518, 519, 520, 521, 522, 523, 524, 525, 526, 527, 528, 529, 530, 531, 532, 533, 534, 535, 536, 537, 538, 539, 540, 541, 542, 543, 544, 545, 546, 547, 548, 549, 550, 551, 552, 553, 554, 555, 556, 557, 558, 559, 560, 561, 562, 563, 564, 565, 566, 567, 568, 569, 570, 571, 572, 573, 574, 575, 576, 577, 578, 579, 580, 581, 582, 583, 584, 585, 586, 587, 588, 589, 590, 591, 592, 593, 594, 595, 596, 597, 598, 599, 600, 601, 602, 603, 604, 605, 606, 607, 608, 609, 610, 611, 612, 613, 614, 615, 616, 617, 618, 619, 620, 621, 622, 623, 624, 625, 626, 627, 628, 629, 630, 631, 632, 633, 634, 635, 636, 637, 638, 639, 640, 641, 642, 643, 644, 645, 646, 647, 648, 649, 650, 651, 652, 653, 654, 655, 656, 657, 658, 659, 660, 661, 662, 663, 664, 665, 666, 667, 668, 669, 670, 671, 672, 673, 674, 675, 676, 677, 678, 679, 680, 681, 682, 683, 684, 685, 686, 687, 688, 689, 690, 691, 692, 693, 694, 695, 696, 697, 698, 699, 700, 701, 702, 703, 704, 705, 706, 707, 708, 709, 710, 711, 712, 713, 714, 715, 716, 717, 718, 719, 720, 721, 722, 723, 724, 725, 726, 727, 728, 729, 730, 731, 732, 733, 734, 735, 736, 737, 738, 739, 740, 741, 742, 743, 744, 745, 746, 747, 748, 749, 750, 751, 752, 753, 754, 755, 756, 757, 758, 759, 760, 761, 762, 763, 764, 765, 766, 767, 768, 769, 770, 771, 772, 773, 774, 775, 776, 777, 778, 779, 780, 781, 782, 783, 784, 785, 786, 787, 788, 789, 790, 791, 792, 793, 794, 795, 796, 797, 798, 799, 800, 801, 802, 803, 804, 805, 806, 807, 808, 809, 810, 811, 812, 813, 814, 815, 816, 817, 818, 819, 820, 821, 822, 823, 824, 825, 826, 827, 828, 829, 830, 831, 832, 833, 834, 835, 836, 837, 838, 839, 840, 841, 842, 843, 844, 845, 846, 847, 848, 849, 850, 851, 852, 853, 854, 855, 856, 857, 858, 859, 860, 861, 862, 863, 864, 865, 866, 867, 868, 869, 870, 871, 872, 873, 874, 875, 876, 877, 878, 879, 880, 881, 882, 883, 884, 885, 886, 887, 888, 889, 890, 891, 892, 893, 894, 895, 896, 897, 898, 899, 900, 901, 902, 903, 904, 905, 906, 907, 908, 909, 910, 911, 912, 913, 914, 915, 916, 917, 918, 919, 920, 921, 922, 923, 924, 925, 926, 927, 928, 929, 930, 931, 932, 933, 934, 935, 936, 937, 938, 939, 940, 941, 942, 943, 944, 945, 946, 947, 948, 949, 950, 951, 952, 953, 954, 955, 956, 957, 958, 959, 960, 961, 962, 963, 964, 965, 966, 967, 968, 969, 970, 971, 972, 973, 974, 975, 976, 977, 978, 979, 980, 981, 982, 983, 984, 985, 986, 987, 988, 989, 990, 991, 992, 993, 994, 995, 996, 997, 998, 999, 1000

MAIN CONTRACTOR :
Gammon

STRUCTURAL ENGINEER :
ARUP

FAÇADE CONSULTANT:
MEINHARDT

NOTE :

- ALL DIMENSIONS ARE IN mm.
- ALL ELEVATIONS ARE VIEWED FROM OUTSIDE.
- ALL DIMENSIONS TO BE VERIFIED ON SITE BEFORE FABRICATION.

LEGEND :

x1 — DETAIL MARK NO.
 x001 — REFER SHEET NO.

- F.F.L. -- FINISHED FLOOR LEVEL
- S.F.L. -- STRUCTURAL FLOOR LEVEL
- ⊗ -- REVERSED DETAIL

NO.	DATE	REVISION	BY
A	08/01/2021	REVISION SUBJECT TO ARCH.COMMENT	lvav

JOB NO. : J-852

PROJECT :
 PROPOSED RESIDENTIAL DEVELOPMENT
 AT 139 - 147 ARGYLE STREET,
 NKIL 6005, 6035 R.P., 6036 R.P.,
 6037 R.P. & 6038 R.P.

TITLE :
 PART PLAN OF
 TOWER 1 (23/F)

DATE : 12-Dec-2019 SCALE : 1:150

DRAWN BY : MN CHECKED BY : DW

美特鋁質有限公司
MIDI ALUMINIUM FABRICATOR LTD.
 Units 6-8, Sunray Industrial Centre, 1/F
 610 Cha Kwo Ling Road, Kowloon
 Tel: 23489211-4 Fax: (852)27727666

DWG NO. : J852-SD-PB-3004 REV. : A

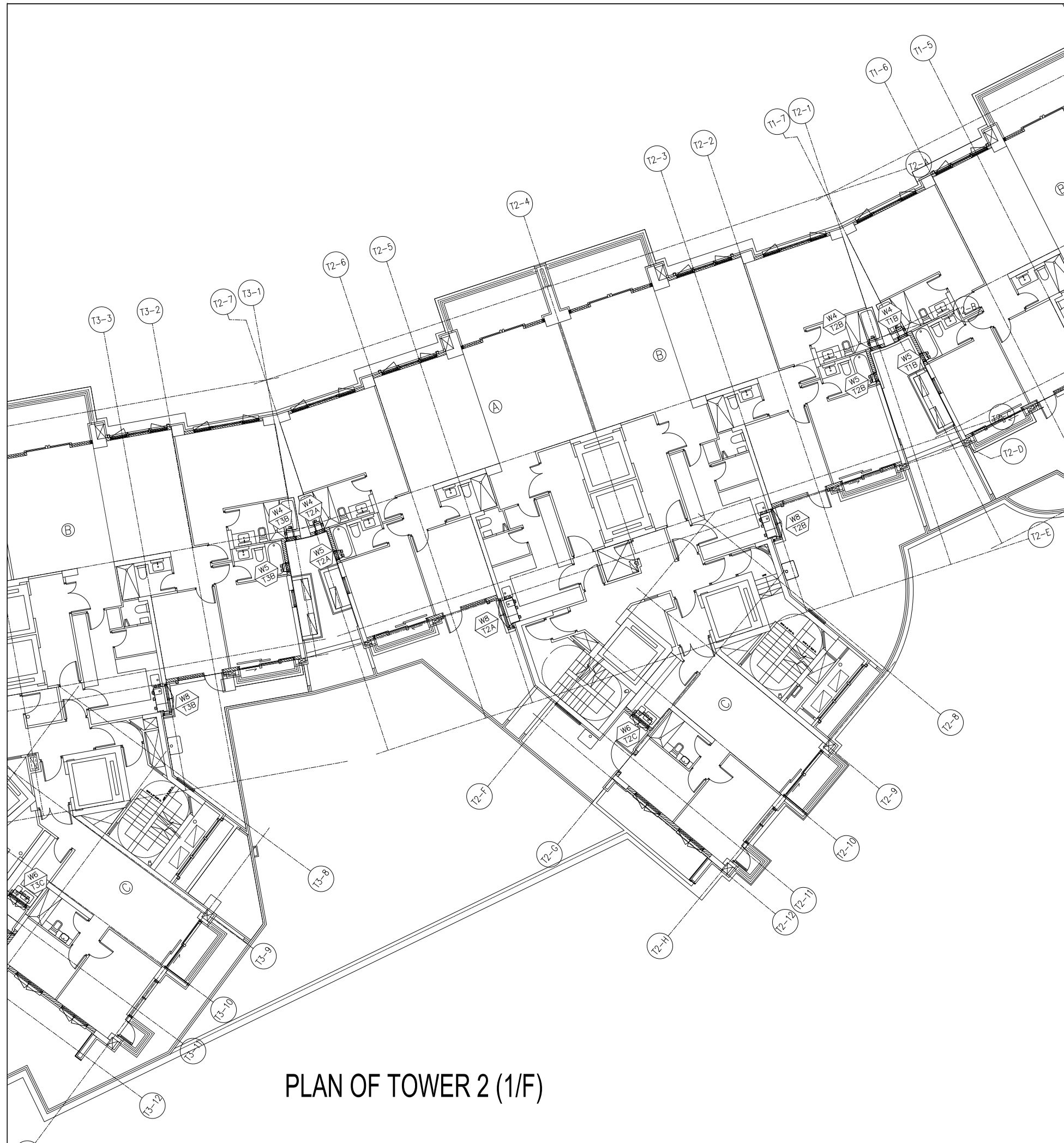

PLAN OF TOWER 2 (1/F)

B.D. REF :

CLIENT :

ARCHITECT :
AGC DESIGN LTD
 101, 102, 103, 104, 105, 106, 107, 108, 109, 110, 111, 112, 113, 114, 115, 116, 117, 118, 119, 120, 121, 122, 123, 124, 125, 126, 127, 128, 129, 130, 131, 132, 133, 134, 135, 136, 137, 138, 139, 140, 141, 142, 143, 144, 145, 146, 147, 148, 149, 150, 151, 152, 153, 154, 155, 156, 157, 158, 159, 160, 161, 162, 163, 164, 165, 166, 167, 168, 169, 170, 171, 172, 173, 174, 175, 176, 177, 178, 179, 180, 181, 182, 183, 184, 185, 186, 187, 188, 189, 190, 191, 192, 193, 194, 195, 196, 197, 198, 199, 200, 201, 202, 203, 204, 205, 206, 207, 208, 209, 210, 211, 212, 213, 214, 215, 216, 217, 218, 219, 220, 221, 222, 223, 224, 225, 226, 227, 228, 229, 230, 231, 232, 233, 234, 235, 236, 237, 238, 239, 240, 241, 242, 243, 244, 245, 246, 247, 248, 249, 250, 251, 252, 253, 254, 255, 256, 257, 258, 259, 260, 261, 262, 263, 264, 265, 266, 267, 268, 269, 270, 271, 272, 273, 274, 275, 276, 277, 278, 279, 280, 281, 282, 283, 284, 285, 286, 287, 288, 289, 290, 291, 292, 293, 294, 295, 296, 297, 298, 299, 300, 301, 302, 303, 304, 305, 306, 307, 308, 309, 310, 311, 312, 313, 314, 315, 316, 317, 318, 319, 320, 321, 322, 323, 324, 325, 326, 327, 328, 329, 330, 331, 332, 333, 334, 335, 336, 337, 338, 339, 340, 341, 342, 343, 344, 345, 346, 347, 348, 349, 350, 351, 352, 353, 354, 355, 356, 357, 358, 359, 360, 361, 362, 363, 364, 365, 366, 367, 368, 369, 370, 371, 372, 373, 374, 375, 376, 377, 378, 379, 380, 381, 382, 383, 384, 385, 386, 387, 388, 389, 390, 391, 392, 393, 394, 395, 396, 397, 398, 399, 400, 401, 402, 403, 404, 405, 406, 407, 408, 409, 410, 411, 412, 413, 414, 415, 416, 417, 418, 419, 420, 421, 422, 423, 424, 425, 426, 427, 428, 429, 430, 431, 432, 433, 434, 435, 436, 437, 438, 439, 440, 441, 442, 443, 444, 445, 446, 447, 448, 449, 450, 451, 452, 453, 454, 455, 456, 457, 458, 459, 460, 461, 462, 463, 464, 465, 466, 467, 468, 469, 470, 471, 472, 473, 474, 475, 476, 477, 478, 479, 480, 481, 482, 483, 484, 485, 486, 487, 488, 489, 490, 491, 492, 493, 494, 495, 496, 497, 498, 499, 500, 501, 502, 503, 504, 505, 506, 507, 508, 509, 510, 511, 512, 513, 514, 515, 516, 517, 518, 519, 520, 521, 522, 523, 524, 525, 526, 527, 528, 529, 530, 531, 532, 533, 534, 535, 536, 537, 538, 539, 540, 541, 542, 543, 544, 545, 546, 547, 548, 549, 550, 551, 552, 553, 554, 555, 556, 557, 558, 559, 560, 561, 562, 563, 564, 565, 566, 567, 568, 569, 570, 571, 572, 573, 574, 575, 576, 577, 578, 579, 580, 581, 582, 583, 584, 585, 586, 587, 588, 589, 590, 591, 592, 593, 594, 595, 596, 597, 598, 599, 600, 601, 602, 603, 604, 605, 606, 607, 608, 609, 610, 611, 612, 613, 614, 615, 616, 617, 618, 619, 620, 621, 622, 623, 624, 625, 626, 627, 628, 629, 630, 631, 632, 633, 634, 635, 636, 637, 638, 639, 640, 641, 642, 643, 644, 645, 646, 647, 648, 649, 650, 651, 652, 653, 654, 655, 656, 657, 658, 659, 660, 661, 662, 663, 664, 665, 666, 667, 668, 669, 670, 671, 672, 673, 674, 675, 676, 677, 678, 679, 680, 681, 682, 683, 684, 685, 686, 687, 688, 689, 690, 691, 692, 693, 694, 695, 696, 697, 698, 699, 700, 701, 702, 703, 704, 705, 706, 707, 708, 709, 710, 711, 712, 713, 714, 715, 716, 717, 718, 719, 720, 721, 722, 723, 724, 725, 726, 727, 728, 729, 730, 731, 732, 733, 734, 735, 736, 737, 738, 739, 740, 741, 742, 743, 744, 745, 746, 747, 748, 749, 750, 751, 752, 753, 754, 755, 756, 757, 758, 759, 760, 761, 762, 763, 764, 765, 766, 767, 768, 769, 770, 771, 772, 773, 774, 775, 776, 777, 778, 779, 780, 781, 782, 783, 784, 785, 786, 787, 788, 789, 790, 791, 792, 793, 794, 795, 796, 797, 798, 799, 800, 801, 802, 803, 804, 805, 806, 807, 808, 809, 810, 811, 812, 813, 814, 815, 816, 817, 818, 819, 820, 821, 822, 823, 824, 825, 826, 827, 828, 829, 830, 831, 832, 833, 834, 835, 836, 837, 838, 839, 840, 841, 842, 843, 844, 845, 846, 847, 848, 849, 850, 851, 852, 853, 854, 855, 856, 857, 858, 859, 860, 861, 862, 863, 864, 865, 866, 867, 868, 869, 870, 871, 872, 873, 874, 875, 876, 877, 878, 879, 880, 881, 882, 883, 884, 885, 886, 887, 888, 889, 890, 891, 892, 893, 894, 895, 896, 897, 898, 899, 900, 901, 902, 903, 904, 905, 906, 907, 908, 909, 910, 911, 912, 913, 914, 915, 916, 917, 918, 919, 920, 921, 922, 923, 924, 925, 926, 927, 928, 929, 930, 931, 932, 933, 934, 935, 936, 937, 938, 939, 940, 941, 942, 943, 944, 945, 946, 947, 948, 949, 950, 951, 952, 953, 954, 955, 956, 957, 958, 959, 960, 961, 962, 963, 964, 965, 966, 967, 968, 969, 970, 971, 972, 973, 974, 975, 976, 977, 978, 979, 980, 981, 982, 983, 984, 985, 986, 987, 988, 989, 990, 991, 992, 993, 994, 995, 996, 997, 998, 999, 1000

MAIN CONTRACTOR :
Gammon

STRUCTURAL ENGINEER :
ARUP

FACADE CONSULTANT:
MEINHARDT

NOTE :
 1. ALL DIMENSIONS ARE IN mm.
 2. ALL ELEVATIONS ARE VIEWED FROM OUTSIDE.
 3. ALL DIMENSIONS TO BE VERIFIED ON SITE BEFORE FABRICATION.

LEGEND :
 (X1) --- DETAIL MARK NO.
 (X001) --- REFER SHEET NO.
 1. F.F.L. --- FINISHED FLOOR LEVEL
 2. S.F.L. --- STRUCTURAL FLOOR LEVEL
 3. (R) --- REVERSED DETAIL

NO.	DATE	REVISED	BY
-----	------	---------	----

JOB NO. : J-852
 PROJECT : PROPOSED RESIDENTIAL DEVELOPMENT AT 139 - 147 ARGYLE STREET, NKIL 6005, 6035 R.P., 6036 R.P., 6037 R.P. & 6038 R.P.

TITLE : PART PLAN OF TOWER 2(1/F)

DATE : 12-Dec-2019 SCALE : 1:150

DRAWN BY : MN CHECKED BY : DW

美特鋁質有限公司
MIDI ALUMINIUM FABRICATOR LTD.
 Units 6-8, Sunray Industrial Centre, 1/F
 610 Cha Kwo Ling Road, Kowloon
 Tel: 23489211-4 Fax: (852)2727666

DWG NO. : J852-SD-PB-3005 REV. : -



PLAN OF TOWER 2 (2/F~21F)

B.D. REF :

CLIENT :

ARCHITECT :
AGC DESIGN LTD
 101, 102, 103, 104, 105, 106, 107, 108, 109, 110, 111, 112, 113, 114, 115, 116, 117, 118, 119, 120, 121, 122, 123, 124, 125, 126, 127, 128, 129, 130, 131, 132, 133, 134, 135, 136, 137, 138, 139, 140, 141, 142, 143, 144, 145, 146, 147, 148, 149, 150, 151, 152, 153, 154, 155, 156, 157, 158, 159, 160, 161, 162, 163, 164, 165, 166, 167, 168, 169, 170, 171, 172, 173, 174, 175, 176, 177, 178, 179, 180, 181, 182, 183, 184, 185, 186, 187, 188, 189, 190, 191, 192, 193, 194, 195, 196, 197, 198, 199, 200, 201, 202, 203, 204, 205, 206, 207, 208, 209, 210, 211, 212, 213, 214, 215, 216, 217, 218, 219, 220, 221, 222, 223, 224, 225, 226, 227, 228, 229, 230, 231, 232, 233, 234, 235, 236, 237, 238, 239, 240, 241, 242, 243, 244, 245, 246, 247, 248, 249, 250, 251, 252, 253, 254, 255, 256, 257, 258, 259, 260, 261, 262, 263, 264, 265, 266, 267, 268, 269, 270, 271, 272, 273, 274, 275, 276, 277, 278, 279, 280, 281, 282, 283, 284, 285, 286, 287, 288, 289, 290, 291, 292, 293, 294, 295, 296, 297, 298, 299, 300, 301, 302, 303, 304, 305, 306, 307, 308, 309, 310, 311, 312, 313, 314, 315, 316, 317, 318, 319, 320, 321, 322, 323, 324, 325, 326, 327, 328, 329, 330, 331, 332, 333, 334, 335, 336, 337, 338, 339, 340, 341, 342, 343, 344, 345, 346, 347, 348, 349, 350, 351, 352, 353, 354, 355, 356, 357, 358, 359, 360, 361, 362, 363, 364, 365, 366, 367, 368, 369, 370, 371, 372, 373, 374, 375, 376, 377, 378, 379, 380, 381, 382, 383, 384, 385, 386, 387, 388, 389, 390, 391, 392, 393, 394, 395, 396, 397, 398, 399, 400, 401, 402, 403, 404, 405, 406, 407, 408, 409, 410, 411, 412, 413, 414, 415, 416, 417, 418, 419, 420, 421, 422, 423, 424, 425, 426, 427, 428, 429, 430, 431, 432, 433, 434, 435, 436, 437, 438, 439, 440, 441, 442, 443, 444, 445, 446, 447, 448, 449, 450, 451, 452, 453, 454, 455, 456, 457, 458, 459, 460, 461, 462, 463, 464, 465, 466, 467, 468, 469, 470, 471, 472, 473, 474, 475, 476, 477, 478, 479, 480, 481, 482, 483, 484, 485, 486, 487, 488, 489, 490, 491, 492, 493, 494, 495, 496, 497, 498, 499, 500, 501, 502, 503, 504, 505, 506, 507, 508, 509, 510, 511, 512, 513, 514, 515, 516, 517, 518, 519, 520, 521, 522, 523, 524, 525, 526, 527, 528, 529, 530, 531, 532, 533, 534, 535, 536, 537, 538, 539, 540, 541, 542, 543, 544, 545, 546, 547, 548, 549, 550, 551, 552, 553, 554, 555, 556, 557, 558, 559, 560, 561, 562, 563, 564, 565, 566, 567, 568, 569, 570, 571, 572, 573, 574, 575, 576, 577, 578, 579, 580, 581, 582, 583, 584, 585, 586, 587, 588, 589, 590, 591, 592, 593, 594, 595, 596, 597, 598, 599, 600, 601, 602, 603, 604, 605, 606, 607, 608, 609, 610, 611, 612, 613, 614, 615, 616, 617, 618, 619, 620, 621, 622, 623, 624, 625, 626, 627, 628, 629, 630, 631, 632, 633, 634, 635, 636, 637, 638, 639, 640, 641, 642, 643, 644, 645, 646, 647, 648, 649, 650, 651, 652, 653, 654, 655, 656, 657, 658, 659, 660, 661, 662, 663, 664, 665, 666, 667, 668, 669, 670, 671, 672, 673, 674, 675, 676, 677, 678, 679, 680, 681, 682, 683, 684, 685, 686, 687, 688, 689, 690, 691, 692, 693, 694, 695, 696, 697, 698, 699, 700, 701, 702, 703, 704, 705, 706, 707, 708, 709, 710, 711, 712, 713, 714, 715, 716, 717, 718, 719, 720, 721, 722, 723, 724, 725, 726, 727, 728, 729, 730, 731, 732, 733, 734, 735, 736, 737, 738, 739, 740, 741, 742, 743, 744, 745, 746, 747, 748, 749, 750, 751, 752, 753, 754, 755, 756, 757, 758, 759, 760, 761, 762, 763, 764, 765, 766, 767, 768, 769, 770, 771, 772, 773, 774, 775, 776, 777, 778, 779, 780, 781, 782, 783, 784, 785, 786, 787, 788, 789, 790, 791, 792, 793, 794, 795, 796, 797, 798, 799, 800, 801, 802, 803, 804, 805, 806, 807, 808, 809, 810, 811, 812, 813, 814, 815, 816, 817, 818, 819, 820, 821, 822, 823, 824, 825, 826, 827, 828, 829, 830, 831, 832, 833, 834, 835, 836, 837, 838, 839, 840, 841, 842, 843, 844, 845, 846, 847, 848, 849, 850, 851, 852, 853, 854, 855, 856, 857, 858, 859, 860, 861, 862, 863, 864, 865, 866, 867, 868, 869, 870, 871, 872, 873, 874, 875, 876, 877, 878, 879, 880, 881, 882, 883, 884, 885, 886, 887, 888, 889, 890, 891, 892, 893, 894, 895, 896, 897, 898, 899, 900, 901, 902, 903, 904, 905, 906, 907, 908, 909, 910, 911, 912, 913, 914, 915, 916, 917, 918, 919, 920, 921, 922, 923, 924, 925, 926, 927, 928, 929, 930, 931, 932, 933, 934, 935, 936, 937, 938, 939, 940, 941, 942, 943, 944, 945, 946, 947, 948, 949, 950, 951, 952, 953, 954, 955, 956, 957, 958, 959, 960, 961, 962, 963, 964, 965, 966, 967, 968, 969, 970, 971, 972, 973, 974, 975, 976, 977, 978, 979, 980, 981, 982, 983, 984, 985, 986, 987, 988, 989, 990, 991, 992, 993, 994, 995, 996, 997, 998, 999, 1000.

MAIN CONTRACTOR :
Gammon

STRUCTURAL ENGINEER :
ARUP

FACADE CONSULTANT:
MEINHARDT

NOTE :
 1. ALL DIMENSIONS ARE IN mm.
 2. ALL ELEVATIONS ARE VIEWED FROM OUTSIDE.
 3. ALL DIMENSIONS TO BE VERIFIED ON SITE BEFORE FABRICATION.

LEGEND :
 (x1) --- DETAIL MARK NO.
 (x001) --- REFER SHEET NO.
 1. F.F.L. --- FINISHED FLOOR LEVEL
 2. S.F.L. --- STRUCTURAL FLOOR LEVEL
 3. (R) --- REVERSED DETAIL

NO.	DATE	REVISED	BY
-----	------	---------	----

JOB NO. : J-852
 PROJECT : PROPOSED RESIDENTIAL DEVELOPMENT AT 139 - 147 ARGYLE STREET, NKIL 6005, 6035 R.P., 6036 R.P., 6037 R.P. & 6038 R.P.

TITLE : PART PLAN OF TOWER 2 (2-21/F)

DATE : 12-Dec-2019 SCALE : 1:150

DRAWN BY : MN CHECKED BY : DW

美特鋁質有限公司
MIDI ALUMINIUM FABRICATOR LTD.
 Units 6-8, Sunray Industrial Centre, 1/F
 610 Cha Kwo Ling Road, Kowloon
 Tel: 23489211-4 Fax: (852)2727666

DWG NO. : J852-SD-PB-3006 REV. : -



PLAN OF TOWER 2 (22F)

B.D. REF :

CLIENT :

ARCHITECT :

AGC
DESIGN LTD

MAIN CONTRACTOR :

Gammon

STRUCTURAL ENGINEER :

ARUP

FACADE CONSULTANT:

MEINHARDT

NOTE :

1. ALL DIMENSIONS ARE IN mm.
2. ALL ELEVATIONS ARE VIEWED FROM OUTSIDE.
3. ALL DIMENSIONS TO BE VERIFIED ON SITE BEFORE FABRICATION.

LEGEND :

- x1 --- DETAIL MARK NO.
- x001 --- REFER SHEET NO.
- 1. F.F.L. --- FINISHED FLOOR LEVEL
- 2. S.F.L. --- STRUCTURAL FLOOR LEVEL
- 3. (R) --- REVERSED DETAIL

NO.	DATE	REVISION	BY
A	07/11/2020	REVISION SUBJECT TO ARCH.COMMENT	Ivan

JOB NO. : J-852
 PROJECT : PROPOSED RESIDENTIAL DEVELOPMENT
 AT 139 - 147 ARGYLE STREET,
 NKIL 6005, 6035 R.P., 6036 R.P.,
 6037 R.P. & 6038 R.P.

TITLE : PART PLAN OF
 TOWER 2 (22/F)

DATE : 12-Dec-2019 SCALE : 1:150

DRAWN BY : MN CHECKED BY : DW

美特鋁質有限公司
MIDI ALUMINIUM FABRICATOR LTD.
 Units 6-8, Sunray Industrial Centre, 1/F
 610 Cha Kwo Ling Road, Kowloon
 Tel: 23489211-4 Fax: (852)27727666

DWG NO. : J852-SD-PB-3007 REV. : A

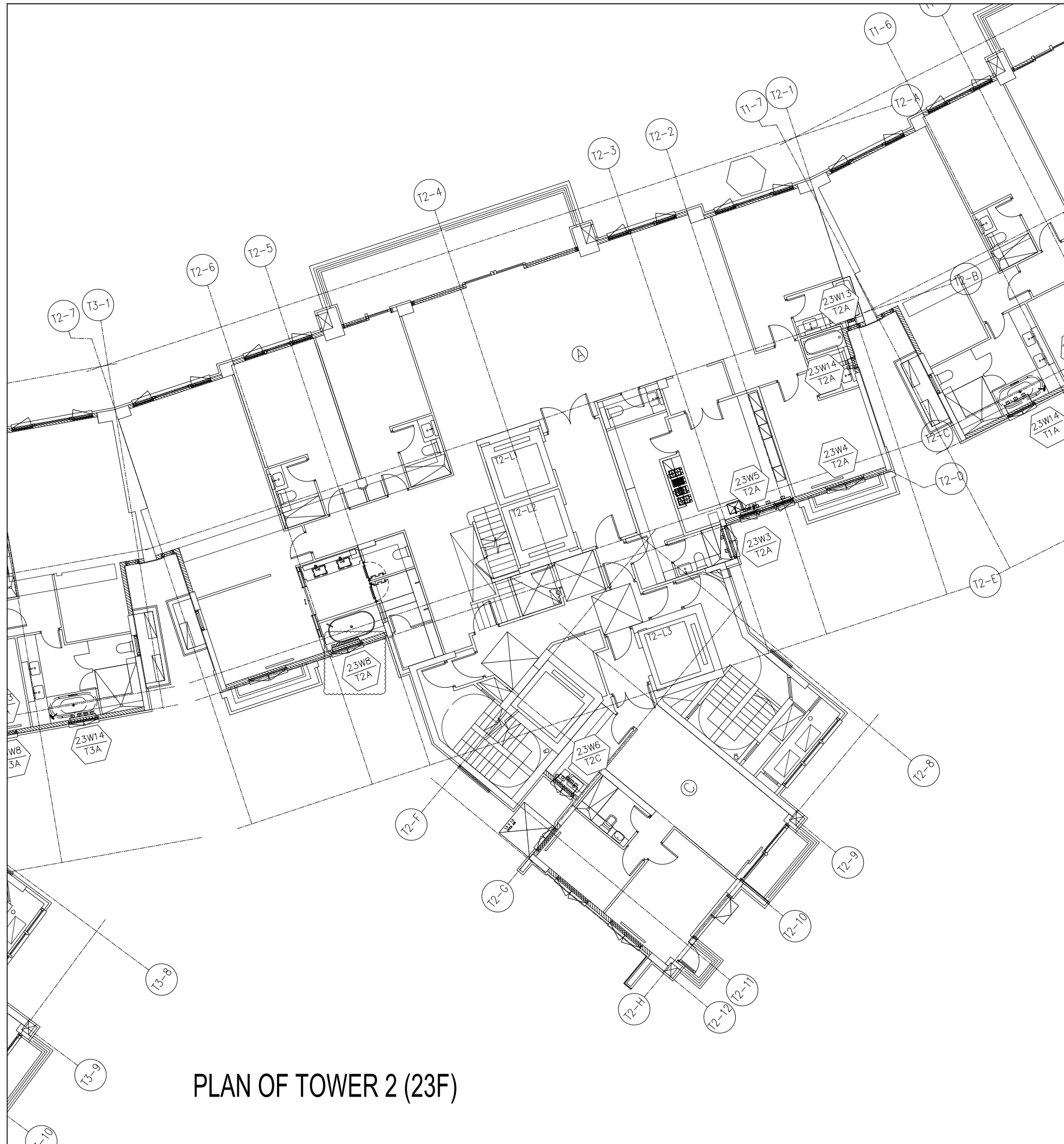

PLAN OF TOWER 2 (23F)

B.D. REF :

CLIENT :

ARCHITECT :
AGC DESIGN LTD
 101, 102, 103, 104, 105, 106, 107, 108, 109, 110, 111, 112, 113, 114, 115, 116, 117, 118, 119, 120, 121, 122, 123, 124, 125, 126, 127, 128, 129, 130, 131, 132, 133, 134, 135, 136, 137, 138, 139, 140, 141, 142, 143, 144, 145, 146, 147, 148, 149, 150, 151, 152, 153, 154, 155, 156, 157, 158, 159, 160, 161, 162, 163, 164, 165, 166, 167, 168, 169, 170, 171, 172, 173, 174, 175, 176, 177, 178, 179, 180, 181, 182, 183, 184, 185, 186, 187, 188, 189, 190, 191, 192, 193, 194, 195, 196, 197, 198, 199, 200, 201, 202, 203, 204, 205, 206, 207, 208, 209, 210, 211, 212, 213, 214, 215, 216, 217, 218, 219, 220, 221, 222, 223, 224, 225, 226, 227, 228, 229, 230, 231, 232, 233, 234, 235, 236, 237, 238, 239, 240, 241, 242, 243, 244, 245, 246, 247, 248, 249, 250, 251, 252, 253, 254, 255, 256, 257, 258, 259, 260, 261, 262, 263, 264, 265, 266, 267, 268, 269, 270, 271, 272, 273, 274, 275, 276, 277, 278, 279, 280, 281, 282, 283, 284, 285, 286, 287, 288, 289, 290, 291, 292, 293, 294, 295, 296, 297, 298, 299, 300, 301, 302, 303, 304, 305, 306, 307, 308, 309, 310, 311, 312, 313, 314, 315, 316, 317, 318, 319, 320, 321, 322, 323, 324, 325, 326, 327, 328, 329, 330, 331, 332, 333, 334, 335, 336, 337, 338, 339, 340, 341, 342, 343, 344, 345, 346, 347, 348, 349, 350, 351, 352, 353, 354, 355, 356, 357, 358, 359, 360, 361, 362, 363, 364, 365, 366, 367, 368, 369, 370, 371, 372, 373, 374, 375, 376, 377, 378, 379, 380, 381, 382, 383, 384, 385, 386, 387, 388, 389, 390, 391, 392, 393, 394, 395, 396, 397, 398, 399, 400, 401, 402, 403, 404, 405, 406, 407, 408, 409, 410, 411, 412, 413, 414, 415, 416, 417, 418, 419, 420, 421, 422, 423, 424, 425, 426, 427, 428, 429, 430, 431, 432, 433, 434, 435, 436, 437, 438, 439, 440, 441, 442, 443, 444, 445, 446, 447, 448, 449, 450, 451, 452, 453, 454, 455, 456, 457, 458, 459, 460, 461, 462, 463, 464, 465, 466, 467, 468, 469, 470, 471, 472, 473, 474, 475, 476, 477, 478, 479, 480, 481, 482, 483, 484, 485, 486, 487, 488, 489, 490, 491, 492, 493, 494, 495, 496, 497, 498, 499, 500, 501, 502, 503, 504, 505, 506, 507, 508, 509, 510, 511, 512, 513, 514, 515, 516, 517, 518, 519, 520, 521, 522, 523, 524, 525, 526, 527, 528, 529, 530, 531, 532, 533, 534, 535, 536, 537, 538, 539, 540, 541, 542, 543, 544, 545, 546, 547, 548, 549, 550, 551, 552, 553, 554, 555, 556, 557, 558, 559, 560, 561, 562, 563, 564, 565, 566, 567, 568, 569, 570, 571, 572, 573, 574, 575, 576, 577, 578, 579, 580, 581, 582, 583, 584, 585, 586, 587, 588, 589, 590, 591, 592, 593, 594, 595, 596, 597, 598, 599, 600, 601, 602, 603, 604, 605, 606, 607, 608, 609, 610, 611, 612, 613, 614, 615, 616, 617, 618, 619, 620, 621, 622, 623, 624, 625, 626, 627, 628, 629, 630, 631, 632, 633, 634, 635, 636, 637, 638, 639, 640, 641, 642, 643, 644, 645, 646, 647, 648, 649, 650, 651, 652, 653, 654, 655, 656, 657, 658, 659, 660, 661, 662, 663, 664, 665, 666, 667, 668, 669, 670, 671, 672, 673, 674, 675, 676, 677, 678, 679, 680, 681, 682, 683, 684, 685, 686, 687, 688, 689, 690, 691, 692, 693, 694, 695, 696, 697, 698, 699, 700, 701, 702, 703, 704, 705, 706, 707, 708, 709, 710, 711, 712, 713, 714, 715, 716, 717, 718, 719, 720, 721, 722, 723, 724, 725, 726, 727, 728, 729, 730, 731, 732, 733, 734, 735, 736, 737, 738, 739, 740, 741, 742, 743, 744, 745, 746, 747, 748, 749, 750, 751, 752, 753, 754, 755, 756, 757, 758, 759, 760, 761, 762, 763, 764, 765, 766, 767, 768, 769, 770, 771, 772, 773, 774, 775, 776, 777, 778, 779, 780, 781, 782, 783, 784, 785, 786, 787, 788, 789, 790, 791, 792, 793, 794, 795, 796, 797, 798, 799, 800, 801, 802, 803, 804, 805, 806, 807, 808, 809, 810, 811, 812, 813, 814, 815, 816, 817, 818, 819, 820, 821, 822, 823, 824, 825, 826, 827, 828, 829, 830, 831, 832, 833, 834, 835, 836, 837, 838, 839, 840, 841, 842, 843, 844, 845, 846, 847, 848, 849, 850, 851, 852, 853, 854, 855, 856, 857, 858, 859, 860, 861, 862, 863, 864, 865, 866, 867, 868, 869, 870, 871, 872, 873, 874, 875, 876, 877, 878, 879, 880, 881, 882, 883, 884, 885, 886, 887, 888, 889, 890, 891, 892, 893, 894, 895, 896, 897, 898, 899, 900, 901, 902, 903, 904, 905, 906, 907, 908, 909, 910, 911, 912, 913, 914, 915, 916, 917, 918, 919, 920, 921, 922, 923, 924, 925, 926, 927, 928, 929, 930, 931, 932, 933, 934, 935, 936, 937, 938, 939, 940, 941, 942, 943, 944, 945, 946, 947, 948, 949, 950, 951, 952, 953, 954, 955, 956, 957, 958, 959, 960, 961, 962, 963, 964, 965, 966, 967, 968, 969, 970, 971, 972, 973, 974, 975, 976, 977, 978, 979, 980, 981, 982, 983, 984, 985, 986, 987, 988, 989, 990, 991, 992, 993, 994, 995, 996, 997, 998, 999, 1000

MAIN CONTRACTOR :
Gammon

STRUCTURAL ENGINEER :
ARUP

FACADE CONSULTANT:
MEINHARDT

NOTE :
 1. ALL DIMENSIONS ARE IN mm.
 2. ALL ELEVATIONS ARE VIEWED FROM OUTSIDE.
 3. ALL DIMENSIONS TO BE VERIFIED ON SITE BEFORE FABRICATION.

LEGEND :
 (x1) --- DETAIL MARK NO.
 (x001) --- REFER SHEET NO.
 1. F.F.L. --- FINISHED FLOOR LEVEL
 2. S.F.L. --- STRUCTURAL FLOOR LEVEL
 3. (R) --- REVERSED DETAIL

NO.	DATE	REVISION	BY
A	08/01/2021	REVISION SUBJECT TO ARCH.COMMENT	Ivan

JOB NO. : J-852
 PROJECT : PROPOSED RESIDENTIAL DEVELOPMENT AT 139 - 147 ARGYLE STREET, NKIL 6005, 6035 R.P., 6036 R.P., 6037 R.P. & 6038 R.P.

TITLE : PART PLAN OF TOWER 2 (23/F)

DATE : 12-Dec-2019 SCALE : 1:150
 DRAWN BY : MN CHECKED BY : DW

美特鋁質有限公司
MIDI ALUMINIUM FABRICATOR LTD.
 Units 6-8, Sunray Industrial Centre, 1/F
 610 Cha Kwo Ling Road, Kowloon
 Tel: 23489211-4 Fax: (852)2727666

DWG NO. : J852-SD-PB-3008 REV. : A



PLAN OF TOWER 3 (1/F)

B.D. REF :

CLIENT :

ARCHITECT :
AGC DESIGN LTD
 161, 162, 163, 164, 165, 166, 167, 168, 169, 170, 171, 172, 173, 174, 175, 176, 177, 178, 179, 180, 181, 182, 183, 184, 185, 186, 187, 188, 189, 190, 191, 192, 193, 194, 195, 196, 197, 198, 199, 200, 201, 202, 203, 204, 205, 206, 207, 208, 209, 210, 211, 212, 213, 214, 215, 216, 217, 218, 219, 220, 221, 222, 223, 224, 225, 226, 227, 228, 229, 230, 231, 232, 233, 234, 235, 236, 237, 238, 239, 240, 241, 242, 243, 244, 245, 246, 247, 248, 249, 250, 251, 252, 253, 254, 255, 256, 257, 258, 259, 260, 261, 262, 263, 264, 265, 266, 267, 268, 269, 270, 271, 272, 273, 274, 275, 276, 277, 278, 279, 280, 281, 282, 283, 284, 285, 286, 287, 288, 289, 290, 291, 292, 293, 294, 295, 296, 297, 298, 299, 300, 301, 302, 303, 304, 305, 306, 307, 308, 309, 310, 311, 312, 313, 314, 315, 316, 317, 318, 319, 320, 321, 322, 323, 324, 325, 326, 327, 328, 329, 330, 331, 332, 333, 334, 335, 336, 337, 338, 339, 340, 341, 342, 343, 344, 345, 346, 347, 348, 349, 350, 351, 352, 353, 354, 355, 356, 357, 358, 359, 360, 361, 362, 363, 364, 365, 366, 367, 368, 369, 370, 371, 372, 373, 374, 375, 376, 377, 378, 379, 380, 381, 382, 383, 384, 385, 386, 387, 388, 389, 390, 391, 392, 393, 394, 395, 396, 397, 398, 399, 400, 401, 402, 403, 404, 405, 406, 407, 408, 409, 410, 411, 412, 413, 414, 415, 416, 417, 418, 419, 420, 421, 422, 423, 424, 425, 426, 427, 428, 429, 430, 431, 432, 433, 434, 435, 436, 437, 438, 439, 440, 441, 442, 443, 444, 445, 446, 447, 448, 449, 450, 451, 452, 453, 454, 455, 456, 457, 458, 459, 460, 461, 462, 463, 464, 465, 466, 467, 468, 469, 470, 471, 472, 473, 474, 475, 476, 477, 478, 479, 480, 481, 482, 483, 484, 485, 486, 487, 488, 489, 490, 491, 492, 493, 494, 495, 496, 497, 498, 499, 500, 501, 502, 503, 504, 505, 506, 507, 508, 509, 510, 511, 512, 513, 514, 515, 516, 517, 518, 519, 520, 521, 522, 523, 524, 525, 526, 527, 528, 529, 530, 531, 532, 533, 534, 535, 536, 537, 538, 539, 540, 541, 542, 543, 544, 545, 546, 547, 548, 549, 550, 551, 552, 553, 554, 555, 556, 557, 558, 559, 560, 561, 562, 563, 564, 565, 566, 567, 568, 569, 570, 571, 572, 573, 574, 575, 576, 577, 578, 579, 580, 581, 582, 583, 584, 585, 586, 587, 588, 589, 590, 591, 592, 593, 594, 595, 596, 597, 598, 599, 600, 601, 602, 603, 604, 605, 606, 607, 608, 609, 610, 611, 612, 613, 614, 615, 616, 617, 618, 619, 620, 621, 622, 623, 624, 625, 626, 627, 628, 629, 630, 631, 632, 633, 634, 635, 636, 637, 638, 639, 640, 641, 642, 643, 644, 645, 646, 647, 648, 649, 650, 651, 652, 653, 654, 655, 656, 657, 658, 659, 660, 661, 662, 663, 664, 665, 666, 667, 668, 669, 670, 671, 672, 673, 674, 675, 676, 677, 678, 679, 680, 681, 682, 683, 684, 685, 686, 687, 688, 689, 690, 691, 692, 693, 694, 695, 696, 697, 698, 699, 700, 701, 702, 703, 704, 705, 706, 707, 708, 709, 710, 711, 712, 713, 714, 715, 716, 717, 718, 719, 720, 721, 722, 723, 724, 725, 726, 727, 728, 729, 730, 731, 732, 733, 734, 735, 736, 737, 738, 739, 740, 741, 742, 743, 744, 745, 746, 747, 748, 749, 750, 751, 752, 753, 754, 755, 756, 757, 758, 759, 760, 761, 762, 763, 764, 765, 766, 767, 768, 769, 770, 771, 772, 773, 774, 775, 776, 777, 778, 779, 780, 781, 782, 783, 784, 785, 786, 787, 788, 789, 790, 791, 792, 793, 794, 795, 796, 797, 798, 799, 800, 801, 802, 803, 804, 805, 806, 807, 808, 809, 810, 811, 812, 813, 814, 815, 816, 817, 818, 819, 820, 821, 822, 823, 824, 825, 826, 827, 828, 829, 830, 831, 832, 833, 834, 835, 836, 837, 838, 839, 840, 841, 842, 843, 844, 845, 846, 847, 848, 849, 850, 851, 852, 853, 854, 855, 856, 857, 858, 859, 860, 861, 862, 863, 864, 865, 866, 867, 868, 869, 870, 871, 872, 873, 874, 875, 876, 877, 878, 879, 880, 881, 882, 883, 884, 885, 886, 887, 888, 889, 890, 891, 892, 893, 894, 895, 896, 897, 898, 899, 900, 901, 902, 903, 904, 905, 906, 907, 908, 909, 910, 911, 912, 913, 914, 915, 916, 917, 918, 919, 920, 921, 922, 923, 924, 925, 926, 927, 928, 929, 930, 931, 932, 933, 934, 935, 936, 937, 938, 939, 940, 941, 942, 943, 944, 945, 946, 947, 948, 949, 950, 951, 952, 953, 954, 955, 956, 957, 958, 959, 960, 961, 962, 963, 964, 965, 966, 967, 968, 969, 970, 971, 972, 973, 974, 975, 976, 977, 978, 979, 980, 981, 982, 983, 984, 985, 986, 987, 988, 989, 990, 991, 992, 993, 994, 995, 996, 997, 998, 999, 1000

MAIN CONTRACTOR :
Gammon

STRUCTURAL ENGINEER :
ARUP

FACADE CONSULTANT:
MEINHARDT

NOTE :
 1. ALL DIMENSIONS ARE IN mm.
 2. ALL ELEVATIONS ARE VIEWED FROM OUTSIDE.
 3. ALL DIMENSIONS TO BE VERIFIED ON SITE BEFORE FABRICATION.

LEGEND :
 x1 — DETAIL MARK NO.
 x001 — REFER SHEET NO.
 1. F.F.L. — FINISHED FLOOR LEVEL
 2. S.F.L. — STRUCTURAL FLOOR LEVEL
 3. (R) — REVERSED DETAIL

NO.	DATE	REVISION	BY
A	07/11/2020	REVISION SUBJECT TO ARCH.COMMENT	lvart

JOB NO. : J-852
 PROJECT :
 PROPOSED RESIDENTIAL DEVELOPMENT
 AT 139 - 147 ARGYLE STREET,
 NKIL 6005, 6035 R.P., 6036 R.P.,
 6037 R.P. & 6038 R.P.

TITLE :
 PART PLAN OF
 TOWER 3 (1/F)

DATE : 12-Dec-2019 SCALE : 1:150

DRAWN BY : MN CHECKED BY : DW

美特鋁質有限公司
MIDI ALUMINIUM FABRICATOR LTD.
 Units 6-8, Sunray Industrial Centre, 1/F
 610 Cha Kwo Ling Road, Kowloon
 Tel: 23489211-4 Fax: (852)2727666

DWG NO. : J852-SD-PB-3009 REV. : A



PLAN OF TOWER 3 (2/F~21F)

B.D. REF :

CLIENT :

ARCHITECT :
AGC DESIGN LTD
 101, 102, 103, 104, 105, 106, 107, 108, 109, 110, 111, 112, 113, 114, 115, 116, 117, 118, 119, 120, 121, 122, 123, 124, 125, 126, 127, 128, 129, 130, 131, 132, 133, 134, 135, 136, 137, 138, 139, 140, 141, 142, 143, 144, 145, 146, 147, 148, 149, 150, 151, 152, 153, 154, 155, 156, 157, 158, 159, 160, 161, 162, 163, 164, 165, 166, 167, 168, 169, 170, 171, 172, 173, 174, 175, 176, 177, 178, 179, 180, 181, 182, 183, 184, 185, 186, 187, 188, 189, 190, 191, 192, 193, 194, 195, 196, 197, 198, 199, 200, 201, 202, 203, 204, 205, 206, 207, 208, 209, 210, 211, 212, 213, 214, 215, 216, 217, 218, 219, 220, 221, 222, 223, 224, 225, 226, 227, 228, 229, 230, 231, 232, 233, 234, 235, 236, 237, 238, 239, 240, 241, 242, 243, 244, 245, 246, 247, 248, 249, 250, 251, 252, 253, 254, 255, 256, 257, 258, 259, 260, 261, 262, 263, 264, 265, 266, 267, 268, 269, 270, 271, 272, 273, 274, 275, 276, 277, 278, 279, 280, 281, 282, 283, 284, 285, 286, 287, 288, 289, 290, 291, 292, 293, 294, 295, 296, 297, 298, 299, 300, 301, 302, 303, 304, 305, 306, 307, 308, 309, 310, 311, 312, 313, 314, 315, 316, 317, 318, 319, 320, 321, 322, 323, 324, 325, 326, 327, 328, 329, 330, 331, 332, 333, 334, 335, 336, 337, 338, 339, 340, 341, 342, 343, 344, 345, 346, 347, 348, 349, 350, 351, 352, 353, 354, 355, 356, 357, 358, 359, 360, 361, 362, 363, 364, 365, 366, 367, 368, 369, 370, 371, 372, 373, 374, 375, 376, 377, 378, 379, 380, 381, 382, 383, 384, 385, 386, 387, 388, 389, 390, 391, 392, 393, 394, 395, 396, 397, 398, 399, 400, 401, 402, 403, 404, 405, 406, 407, 408, 409, 410, 411, 412, 413, 414, 415, 416, 417, 418, 419, 420, 421, 422, 423, 424, 425, 426, 427, 428, 429, 430, 431, 432, 433, 434, 435, 436, 437, 438, 439, 440, 441, 442, 443, 444, 445, 446, 447, 448, 449, 450, 451, 452, 453, 454, 455, 456, 457, 458, 459, 460, 461, 462, 463, 464, 465, 466, 467, 468, 469, 470, 471, 472, 473, 474, 475, 476, 477, 478, 479, 480, 481, 482, 483, 484, 485, 486, 487, 488, 489, 490, 491, 492, 493, 494, 495, 496, 497, 498, 499, 500, 501, 502, 503, 504, 505, 506, 507, 508, 509, 510, 511, 512, 513, 514, 515, 516, 517, 518, 519, 520, 521, 522, 523, 524, 525, 526, 527, 528, 529, 530, 531, 532, 533, 534, 535, 536, 537, 538, 539, 540, 541, 542, 543, 544, 545, 546, 547, 548, 549, 550, 551, 552, 553, 554, 555, 556, 557, 558, 559, 560, 561, 562, 563, 564, 565, 566, 567, 568, 569, 570, 571, 572, 573, 574, 575, 576, 577, 578, 579, 580, 581, 582, 583, 584, 585, 586, 587, 588, 589, 590, 591, 592, 593, 594, 595, 596, 597, 598, 599, 600, 601, 602, 603, 604, 605, 606, 607, 608, 609, 610, 611, 612, 613, 614, 615, 616, 617, 618, 619, 620, 621, 622, 623, 624, 625, 626, 627, 628, 629, 630, 631, 632, 633, 634, 635, 636, 637, 638, 639, 640, 641, 642, 643, 644, 645, 646, 647, 648, 649, 650, 651, 652, 653, 654, 655, 656, 657, 658, 659, 660, 661, 662, 663, 664, 665, 666, 667, 668, 669, 670, 671, 672, 673, 674, 675, 676, 677, 678, 679, 680, 681, 682, 683, 684, 685, 686, 687, 688, 689, 690, 691, 692, 693, 694, 695, 696, 697, 698, 699, 700, 701, 702, 703, 704, 705, 706, 707, 708, 709, 710, 711, 712, 713, 714, 715, 716, 717, 718, 719, 720, 721, 722, 723, 724, 725, 726, 727, 728, 729, 730, 731, 732, 733, 734, 735, 736, 737, 738, 739, 740, 741, 742, 743, 744, 745, 746, 747, 748, 749, 750, 751, 752, 753, 754, 755, 756, 757, 758, 759, 760, 761, 762, 763, 764, 765, 766, 767, 768, 769, 770, 771, 772, 773, 774, 775, 776, 777, 778, 779, 780, 781, 782, 783, 784, 785, 786, 787, 788, 789, 790, 791, 792, 793, 794, 795, 796, 797, 798, 799, 800, 801, 802, 803, 804, 805, 806, 807, 808, 809, 810, 811, 812, 813, 814, 815, 816, 817, 818, 819, 820, 821, 822, 823, 824, 825, 826, 827, 828, 829, 830, 831, 832, 833, 834, 835, 836, 837, 838, 839, 840, 841, 842, 843, 844, 845, 846, 847, 848, 849, 850, 851, 852, 853, 854, 855, 856, 857, 858, 859, 860, 861, 862, 863, 864, 865, 866, 867, 868, 869, 870, 871, 872, 873, 874, 875, 876, 877, 878, 879, 880, 881, 882, 883, 884, 885, 886, 887, 888, 889, 890, 891, 892, 893, 894, 895, 896, 897, 898, 899, 900, 901, 902, 903, 904, 905, 906, 907, 908, 909, 910, 911, 912, 913, 914, 915, 916, 917, 918, 919, 920, 921, 922, 923, 924, 925, 926, 927, 928, 929, 930, 931, 932, 933, 934, 935, 936, 937, 938, 939, 940, 941, 942, 943, 944, 945, 946, 947, 948, 949, 950, 951, 952, 953, 954, 955, 956, 957, 958, 959, 960, 961, 962, 963, 964, 965, 966, 967, 968, 969, 970, 971, 972, 973, 974, 975, 976, 977, 978, 979, 980, 981, 982, 983, 984, 985, 986, 987, 988, 989, 990, 991, 992, 993, 994, 995, 996, 997, 998, 999, 1000

MAIN CONTRACTOR :
Gammon

STRUCTURAL ENGINEER :
ARUP

FACADE CONSULTANT:
MEINHARDT

NOTE :
 1. ALL DIMENSIONS ARE IN mm.
 2. ALL ELEVATIONS ARE VIEWED FROM OUTSIDE.
 3. ALL DIMENSIONS TO BE VERIFIED ON SITE BEFORE FABRICATION.

LEGEND :
 x1 — DETAIL MARK NO.
 x001 — REFER SHEET NO.
 1. F.F.L. — FINISHED FLOOR LEVEL
 2. S.F.L. — STRUCTURAL FLOOR LEVEL
 3. (R) — REVERSED DETAIL

B	08/01/2021	REVISION SUBJECT TO ARCH.COMMENT	Ivan
A	07/11/2020	REVISION SUBJECT TO ARCH.COMMENT	Ivan
NO.	DATE	REVISION	BY

JOB NO. : J-852
 PROJECT :
 PROPOSED RESIDENTIAL DEVELOPMENT
 AT 139 - 147 ARGYLE STREET,
 NKIL 6005, 6035 R.P., 6036 R.P.,
 6037 R.P. & 6038 R.P.

TITLE :
 PART PLAN OF
 TOWER 3 (2-21/F)

DATE : 12-Dec-2019 SCALE : 1:150

DRAWN BY : MN CHECKED BY : DW

美特鋁質有限公司
MIDI ALUMINIUM FABRICATOR LTD.
 Units 6-8, Sunray Industrial Centre, 1/F
 610 Cha Kwo Ling Road, Kowloon
 Tel: 23489211-4 Fax: (852)2727666

DWG NO. : J852-SD-PB-3010 REV. : B

ELEVATION

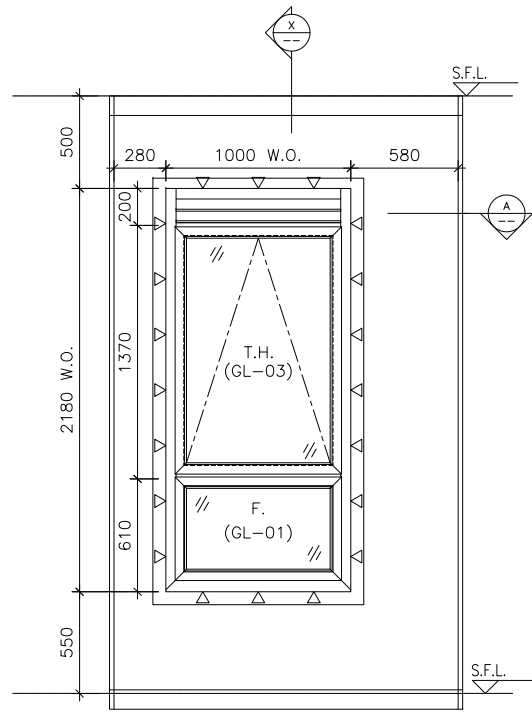

ELEVATION

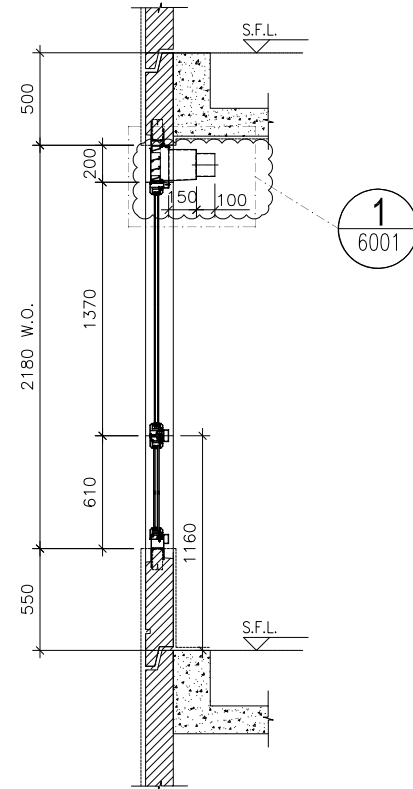

SECTION "X-X"

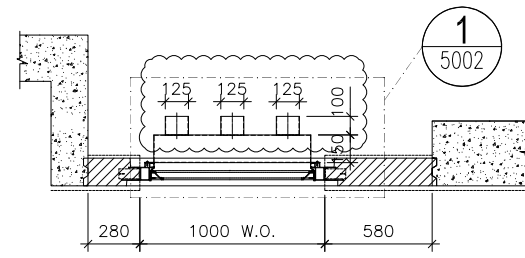

PART PLAN A

WINDOW MARK



LOCATION 1/F-20/F M.B. AT TOWER 1 FLAT A

SECTION 70mm ALUM. SECTION

GLAZING GL-01, GL-03

QUANTITY 17

REMARKS FACADE (PF-15)

B.D. REF :

CLIENT :

ARCHITECT :
AGC DESIGN LTD
 101, 102, 103, 104, 105, 106, 107, 108, 109, 110, 111, 112, 113, 114, 115, 116, 117, 118, 119, 120, 121, 122, 123, 124, 125, 126, 127, 128, 129, 130, 131, 132, 133, 134, 135, 136, 137, 138, 139, 140, 141, 142, 143, 144, 145, 146, 147, 148, 149, 150, 151, 152, 153, 154, 155, 156, 157, 158, 159, 160, 161, 162, 163, 164, 165, 166, 167, 168, 169, 170, 171, 172, 173, 174, 175, 176, 177, 178, 179, 180, 181, 182, 183, 184, 185, 186, 187, 188, 189, 190, 191, 192, 193, 194, 195, 196, 197, 198, 199, 200, 201, 202, 203, 204, 205, 206, 207, 208, 209, 210, 211, 212, 213, 214, 215, 216, 217, 218, 219, 220, 221, 222, 223, 224, 225, 226, 227, 228, 229, 230, 231, 232, 233, 234, 235, 236, 237, 238, 239, 240, 241, 242, 243, 244, 245, 246, 247, 248, 249, 250, 251, 252, 253, 254, 255, 256, 257, 258, 259, 260, 261, 262, 263, 264, 265, 266, 267, 268, 269, 270, 271, 272, 273, 274, 275, 276, 277, 278, 279, 280, 281, 282, 283, 284, 285, 286, 287, 288, 289, 290, 291, 292, 293, 294, 295, 296, 297, 298, 299, 300, 301, 302, 303, 304, 305, 306, 307, 308, 309, 310, 311, 312, 313, 314, 315, 316, 317, 318, 319, 320, 321, 322, 323, 324, 325, 326, 327, 328, 329, 330, 331, 332, 333, 334, 335, 336, 337, 338, 339, 340, 341, 342, 343, 344, 345, 346, 347, 348, 349, 350, 351, 352, 353, 354, 355, 356, 357, 358, 359, 360, 361, 362, 363, 364, 365, 366, 367, 368, 369, 370, 371, 372, 373, 374, 375, 376, 377, 378, 379, 380, 381, 382, 383, 384, 385, 386, 387, 388, 389, 390, 391, 392, 393, 394, 395, 396, 397, 398, 399, 400, 401, 402, 403, 404, 405, 406, 407, 408, 409, 410, 411, 412, 413, 414, 415, 416, 417, 418, 419, 420, 421, 422, 423, 424, 425, 426, 427, 428, 429, 430, 431, 432, 433, 434, 435, 436, 437, 438, 439, 440, 441, 442, 443, 444, 445, 446, 447, 448, 449, 450, 451, 452, 453, 454, 455, 456, 457, 458, 459, 460, 461, 462, 463, 464, 465, 466, 467, 468, 469, 470, 471, 472, 473, 474, 475, 476, 477, 478, 479, 480, 481, 482, 483, 484, 485, 486, 487, 488, 489, 490, 491, 492, 493, 494, 495, 496, 497, 498, 499, 500, 501, 502, 503, 504, 505, 506, 507, 508, 509, 510, 511, 512, 513, 514, 515, 516, 517, 518, 519, 520, 521, 522, 523, 524, 525, 526, 527, 528, 529, 530, 531, 532, 533, 534, 535, 536, 537, 538, 539, 540, 541, 542, 543, 544, 545, 546, 547, 548, 549, 550, 551, 552, 553, 554, 555, 556, 557, 558, 559, 560, 561, 562, 563, 564, 565, 566, 567, 568, 569, 570, 571, 572, 573, 574, 575, 576, 577, 578, 579, 580, 581, 582, 583, 584, 585, 586, 587, 588, 589, 590, 591, 592, 593, 594, 595, 596, 597, 598, 599, 600, 601, 602, 603, 604, 605, 606, 607, 608, 609, 610, 611, 612, 613, 614, 615, 616, 617, 618, 619, 620, 621, 622, 623, 624, 625, 626, 627, 628, 629, 630, 631, 632, 633, 634, 635, 636, 637, 638, 639, 640, 641, 642, 643, 644, 645, 646, 647, 648, 649, 650, 651, 652, 653, 654, 655, 656, 657, 658, 659, 660, 661, 662, 663, 664, 665, 666, 667, 668, 669, 670, 671, 672, 673, 674, 675, 676, 677, 678, 679, 680, 681, 682, 683, 684, 685, 686, 687, 688, 689, 690, 691, 692, 693, 694, 695, 696, 697, 698, 699, 700, 701, 702, 703, 704, 705, 706, 707, 708, 709, 710, 711, 712, 713, 714, 715, 716, 717, 718, 719, 720, 721, 722, 723, 724, 725, 726, 727, 728, 729, 730, 731, 732, 733, 734, 735, 736, 737, 738, 739, 740, 741, 742, 743, 744, 745, 746, 747, 748, 749, 750, 751, 752, 753, 754, 755, 756, 757, 758, 759, 760, 761, 762, 763, 764, 765, 766, 767, 768, 769, 770, 771, 772, 773, 774, 775, 776, 777, 778, 779, 780, 781, 782, 783, 784, 785, 786, 787, 788, 789, 790, 791, 792, 793, 794, 795, 796, 797, 798, 799, 800, 801, 802, 803, 804, 805, 806, 807, 808, 809, 810, 811, 812, 813, 814, 815, 816, 817, 818, 819, 820, 821, 822, 823, 824, 825, 826, 827, 828, 829, 830, 831, 832, 833, 834, 835, 836, 837, 838, 839, 840, 841, 842, 843, 844, 845, 846, 847, 848, 849, 850, 851, 852, 853, 854, 855, 856, 857, 858, 859, 860, 861, 862, 863, 864, 865, 866, 867, 868, 869, 870, 871, 872, 873, 874, 875, 876, 877, 878, 879, 880, 881, 882, 883, 884, 885, 886, 887, 888, 889, 890, 891, 892, 893, 894, 895, 896, 897, 898, 899, 900, 901, 902, 903, 904, 905, 906, 907, 908, 909, 910, 911, 912, 913, 914, 915, 916, 917, 918, 919, 920, 921, 922, 923, 924, 925, 926, 927, 928, 929, 930, 931, 932, 933, 934, 935, 936, 937, 938, 939, 940, 941, 942, 943, 944, 945, 946, 947, 948, 949, 950, 951, 952, 953, 954, 955, 956, 957, 958, 959, 960, 961, 962, 963, 964, 965, 966, 967, 968, 969, 970, 971, 972, 973, 974, 975, 976, 977, 978, 979, 980, 981, 982, 983, 984, 985, 986, 987, 988, 989, 990, 991, 992, 993, 994, 995, 996, 997, 998, 999, 1000

MAIN CONTRACTOR :
Gammon

STRUCTURAL ENGINEER :
ARUP

FACADE CONSULTANT:
MEINHARDT

NOTE :
 1. ALL DIMENSIONS ARE IN mm.
 2. ALL ELEVATIONS ARE VIEWED FROM OUTSIDE.
 3. ALL DIMENSIONS TO BE VERIFIED ON SITE BEFORE FABRICATION.

LEGEND :
 (X1) --- DETAIL MARK NO.
 (X001) --- REFER SHEET NO.
 1. F.F.L. --- FINISHED FLOOR LEVEL
 2. S.F.L. --- STRUCTURAL FLOOR LEVEL
 3. (R) --- REVERSED DETAIL
 4. ▲ --- FIXING LOCATION
 5. △ --- FIXING LUG LOCATION
 6. GLASS LEGEND
 GL01 -- 8mm+12mm AIR GAP+10mm THK. I.G.U.
 GL01a -- 8mm+9mm AIR GAP+12mm THK. I.G.U.
 GL03 -- 6mm+12mm AIR GAP+6mm THK. I.G.U.
 GL04 -- 10mm THK. TEMPERED GLASS (PROTECTIVE BARRIER)
 GL05 -- 6mm+12mm AIR GAP+8mm THK. I.G.U.

NO.	DATE	REVISION	BY
A	07/11/2020	REVISION SUBJECT TO ARCH.COMMENT	lvart

JOB NO. : J-852
 PROJECT :
 PROPOSED RESIDENTIAL DEVELOPMENT
 AT 139 - 147 ARGYLE STREET,
 NKIL 6005, 6035 R.P., 6036 R.P.,
 6037 R.P. & 6038 R.P.

TITLE :
 SCHEDULE FOR Plenum Box
 AT TOWER 1 (1-21F)

DATE : 05-Dec-19 SCALE : 1:40
 DRAWN BY : MN CHECKED BY : DW

美特鋁質有限公司
MIDI ALUMINIUM FABRICATOR LTD.
 Units 6-8, Sunray Industrial Centre, 1/F
 610 Cha Kwo Ling Road, Kowloon
 Tel:23489211-4 Fax:(852)2727666
 DWG NO. : J852-SD-PB-4101 REV. : A

ELEVATION

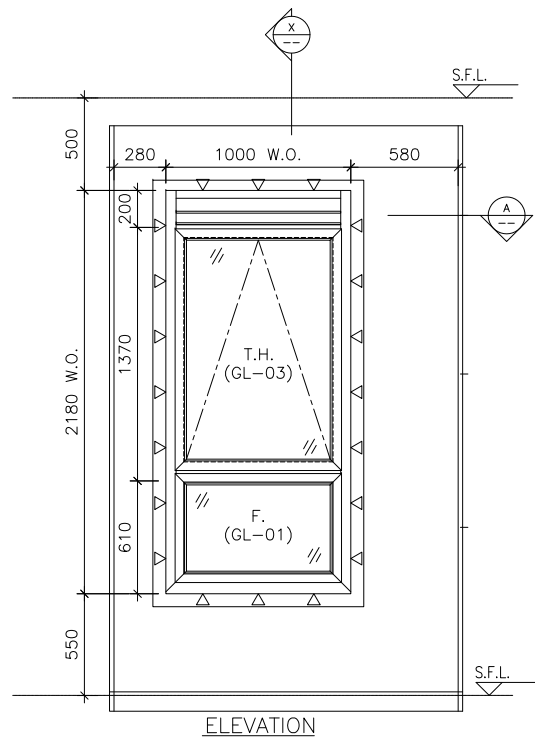

ELEVATION

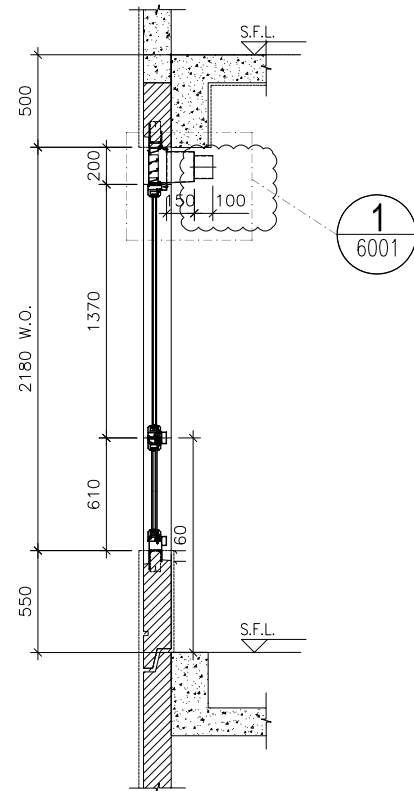

SECTION "X-X"

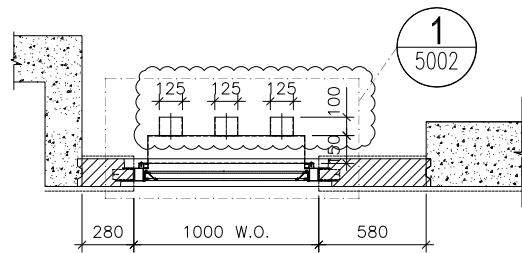

PART PLAN A

WINDOW MARK



LOCATION 21/F M.B. AT TOWER 1 FLAT A

SECTION 70mm ALUM. SECTION

GLAZING GL-01, GL-03

QUANTITY 1

REMARKS FACADE (PF-15)

B.D. REF :

CLIENT :

ARCHITECT :
AGC DESIGN LTD
 101, 102, 103, 104, 105, 106, 107, 108, 109, 110, 111, 112, 113, 114, 115, 116, 117, 118, 119, 120, 121, 122, 123, 124, 125, 126, 127, 128, 129, 130, 131, 132, 133, 134, 135, 136, 137, 138, 139, 140, 141, 142, 143, 144, 145, 146, 147, 148, 149, 150, 151, 152, 153, 154, 155, 156, 157, 158, 159, 160, 161, 162, 163, 164, 165, 166, 167, 168, 169, 170, 171, 172, 173, 174, 175, 176, 177, 178, 179, 180, 181, 182, 183, 184, 185, 186, 187, 188, 189, 190, 191, 192, 193, 194, 195, 196, 197, 198, 199, 200, 201, 202, 203, 204, 205, 206, 207, 208, 209, 210, 211, 212, 213, 214, 215, 216, 217, 218, 219, 220, 221, 222, 223, 224, 225, 226, 227, 228, 229, 230, 231, 232, 233, 234, 235, 236, 237, 238, 239, 240, 241, 242, 243, 244, 245, 246, 247, 248, 249, 250, 251, 252, 253, 254, 255, 256, 257, 258, 259, 260, 261, 262, 263, 264, 265, 266, 267, 268, 269, 270, 271, 272, 273, 274, 275, 276, 277, 278, 279, 280, 281, 282, 283, 284, 285, 286, 287, 288, 289, 290, 291, 292, 293, 294, 295, 296, 297, 298, 299, 300, 301, 302, 303, 304, 305, 306, 307, 308, 309, 310, 311, 312, 313, 314, 315, 316, 317, 318, 319, 320, 321, 322, 323, 324, 325, 326, 327, 328, 329, 330, 331, 332, 333, 334, 335, 336, 337, 338, 339, 340, 341, 342, 343, 344, 345, 346, 347, 348, 349, 350, 351, 352, 353, 354, 355, 356, 357, 358, 359, 360, 361, 362, 363, 364, 365, 366, 367, 368, 369, 370, 371, 372, 373, 374, 375, 376, 377, 378, 379, 380, 381, 382, 383, 384, 385, 386, 387, 388, 389, 390, 391, 392, 393, 394, 395, 396, 397, 398, 399, 400, 401, 402, 403, 404, 405, 406, 407, 408, 409, 410, 411, 412, 413, 414, 415, 416, 417, 418, 419, 420, 421, 422, 423, 424, 425, 426, 427, 428, 429, 430, 431, 432, 433, 434, 435, 436, 437, 438, 439, 440, 441, 442, 443, 444, 445, 446, 447, 448, 449, 450, 451, 452, 453, 454, 455, 456, 457, 458, 459, 460, 461, 462, 463, 464, 465, 466, 467, 468, 469, 470, 471, 472, 473, 474, 475, 476, 477, 478, 479, 480, 481, 482, 483, 484, 485, 486, 487, 488, 489, 490, 491, 492, 493, 494, 495, 496, 497, 498, 499, 500, 501, 502, 503, 504, 505, 506, 507, 508, 509, 510, 511, 512, 513, 514, 515, 516, 517, 518, 519, 520, 521, 522, 523, 524, 525, 526, 527, 528, 529, 530, 531, 532, 533, 534, 535, 536, 537, 538, 539, 540, 541, 542, 543, 544, 545, 546, 547, 548, 549, 550, 551, 552, 553, 554, 555, 556, 557, 558, 559, 560, 561, 562, 563, 564, 565, 566, 567, 568, 569, 570, 571, 572, 573, 574, 575, 576, 577, 578, 579, 580, 581, 582, 583, 584, 585, 586, 587, 588, 589, 590, 591, 592, 593, 594, 595, 596, 597, 598, 599, 600, 601, 602, 603, 604, 605, 606, 607, 608, 609, 610, 611, 612, 613, 614, 615, 616, 617, 618, 619, 620, 621, 622, 623, 624, 625, 626, 627, 628, 629, 630, 631, 632, 633, 634, 635, 636, 637, 638, 639, 640, 641, 642, 643, 644, 645, 646, 647, 648, 649, 650, 651, 652, 653, 654, 655, 656, 657, 658, 659, 660, 661, 662, 663, 664, 665, 666, 667, 668, 669, 670, 671, 672, 673, 674, 675, 676, 677, 678, 679, 680, 681, 682, 683, 684, 685, 686, 687, 688, 689, 690, 691, 692, 693, 694, 695, 696, 697, 698, 699, 700, 701, 702, 703, 704, 705, 706, 707, 708, 709, 710, 711, 712, 713, 714, 715, 716, 717, 718, 719, 720, 721, 722, 723, 724, 725, 726, 727, 728, 729, 730, 731, 732, 733, 734, 735, 736, 737, 738, 739, 740, 741, 742, 743, 744, 745, 746, 747, 748, 749, 750, 751, 752, 753, 754, 755, 756, 757, 758, 759, 760, 761, 762, 763, 764, 765, 766, 767, 768, 769, 770, 771, 772, 773, 774, 775, 776, 777, 778, 779, 780, 781, 782, 783, 784, 785, 786, 787, 788, 789, 790, 791, 792, 793, 794, 795, 796, 797, 798, 799, 800, 801, 802, 803, 804, 805, 806, 807, 808, 809, 810, 811, 812, 813, 814, 815, 816, 817, 818, 819, 820, 821, 822, 823, 824, 825, 826, 827, 828, 829, 830, 831, 832, 833, 834, 835, 836, 837, 838, 839, 840, 841, 842, 843, 844, 845, 846, 847, 848, 849, 850, 851, 852, 853, 854, 855, 856, 857, 858, 859, 860, 861, 862, 863, 864, 865, 866, 867, 868, 869, 870, 871, 872, 873, 874, 875, 876, 877, 878, 879, 880, 881, 882, 883, 884, 885, 886, 887, 888, 889, 890, 891, 892, 893, 894, 895, 896, 897, 898, 899, 900, 901, 902, 903, 904, 905, 906, 907, 908, 909, 910, 911, 912, 913, 914, 915, 916, 917, 918, 919, 920, 921, 922, 923, 924, 925, 926, 927, 928, 929, 930, 931, 932, 933, 934, 935, 936, 937, 938, 939, 940, 941, 942, 943, 944, 945, 946, 947, 948, 949, 950, 951, 952, 953, 954, 955, 956, 957, 958, 959, 960, 961, 962, 963, 964, 965, 966, 967, 968, 969, 970, 971, 972, 973, 974, 975, 976, 977, 978, 979, 980, 981, 982, 983, 984, 985, 986, 987, 988, 989, 990, 991, 992, 993, 994, 995, 996, 997, 998, 999, 1000

MAIN CONTRACTOR :
Gammon

STRUCTURAL ENGINEER :
ARUP

FACADE CONSULTANT:
MEINHARDT

NOTE :
 1. ALL DIMENSIONS ARE IN mm.
 2. ALL ELEVATIONS ARE VIEWED FROM OUTSIDE.
 3. ALL DIMENSIONS TO BE VERIFIED ON SITE BEFORE FABRICATION.

LEGEND :
 (x1) --- DETAIL MARK NO.
 (x001) --- REFER SHEET NO.
 1. F.F.L. --- FINISHED FLOOR LEVEL
 2. S.F.L. --- STRUCTURAL FLOOR LEVEL
 3. (R) --- REVERSED DETAIL
 4. (A) --- FIXING LOCATION
 5. (Δ) --- FIXING LUG LOCATION
 6. GLASS LEGEND
 GL01 --- 8mm+12mm AIR GAP+10mm THK. I.G.U.
 GL01a --- 8mm+9mm AIR GAP+12mm THK. I.G.U.
 GL03 --- 6mm+12mm AIR GAP+6mm THK. I.G.U.
 GL04 --- 10mm THK. TEMPERED GLASS (PROTECTIVE BARRIER)
 GL05 --- 6mm+12mm AIR GAP+8mm THK. I.G.U.

NO.	DATE	REVISION	BY
A	07/11/2020	REVISION SUBJECT TO ARCH.COMMENT	lvart

JOB NO. : J-852
 PROJECT : PROPOSED RESIDENTIAL DEVELOPMENT AT 139 - 147 ARGYLE STREET, NKIL 6005, 6035 R.P., 6036 R.P., 6037 R.P. & 6038 R.P.

TITLE : SCHEDULE FOR Plenum Box AT TOWER 1 (1-21F)

DATE : 22-Apr-20 SCALE : 1:40
 DRAWN BY : MN CHECKED BY : DW

美特鋁質有限公司
MIDI ALUMINIUM FABRICATOR LTD.
 Units 6-8, Sunray Industrial Centre, 1/F
 610 Cha Kwo Ling Road, Kowloon
 Tel:23489211-4 Fax:(852)2727666
 DWG NO. : J852-SD-PB-4101A REV. : A

ELEVATION

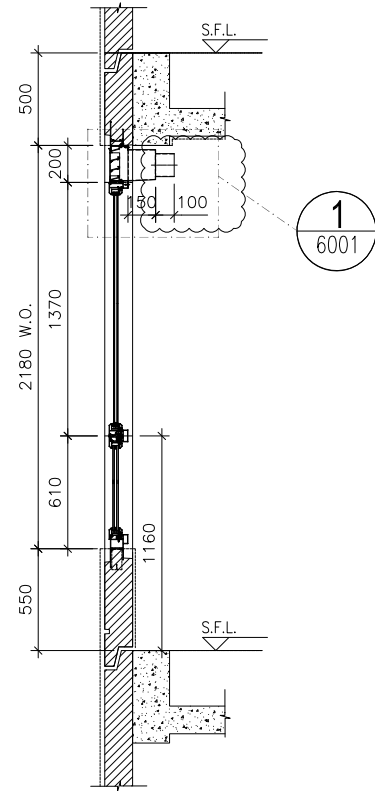
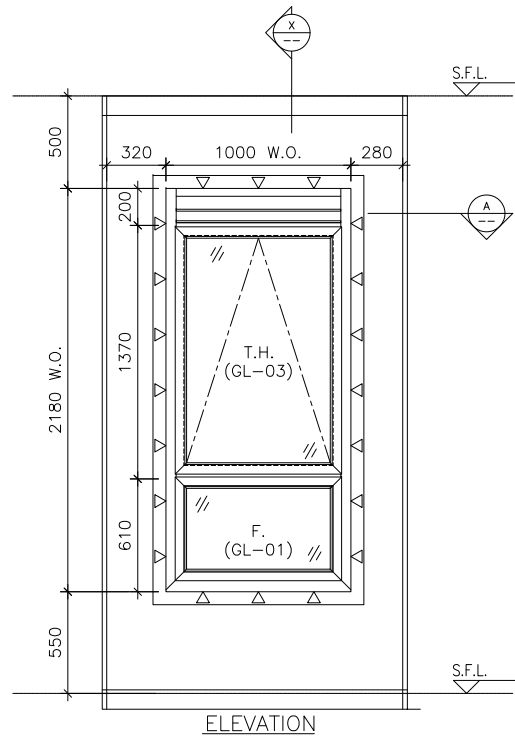

SECTION "X-X"

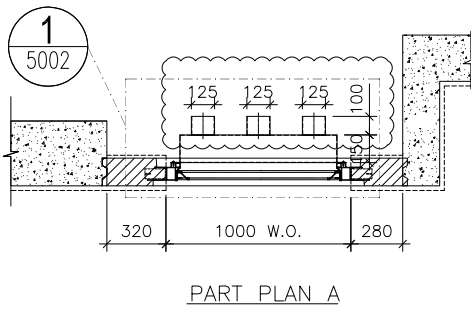

PART PLAN A

WINDOW MARK



LOCATION 1/F-20/F EN.B. AT TOWER 1 FLAT A

SECTION 70mm ALUM. SECTION

GLAZING GL-01, GL-03

QUANTITY 17

REMARKS FACADE (PF-16)

B.D. REF :

CLIENT :

ARCHITECT :
AGC DESIGN LTD
 101, 102, 103, 104, 105, 106, 107, 108, 109, 110, 111, 112, 113, 114, 115, 116, 117, 118, 119, 120, 121, 122, 123, 124, 125, 126, 127, 128, 129, 130, 131, 132, 133, 134, 135, 136, 137, 138, 139, 140, 141, 142, 143, 144, 145, 146, 147, 148, 149, 150, 151, 152, 153, 154, 155, 156, 157, 158, 159, 160, 161, 162, 163, 164, 165, 166, 167, 168, 169, 170, 171, 172, 173, 174, 175, 176, 177, 178, 179, 180, 181, 182, 183, 184, 185, 186, 187, 188, 189, 190, 191, 192, 193, 194, 195, 196, 197, 198, 199, 200, 201, 202, 203, 204, 205, 206, 207, 208, 209, 210, 211, 212, 213, 214, 215, 216, 217, 218, 219, 220, 221, 222, 223, 224, 225, 226, 227, 228, 229, 230, 231, 232, 233, 234, 235, 236, 237, 238, 239, 240, 241, 242, 243, 244, 245, 246, 247, 248, 249, 250, 251, 252, 253, 254, 255, 256, 257, 258, 259, 260, 261, 262, 263, 264, 265, 266, 267, 268, 269, 270, 271, 272, 273, 274, 275, 276, 277, 278, 279, 280, 281, 282, 283, 284, 285, 286, 287, 288, 289, 290, 291, 292, 293, 294, 295, 296, 297, 298, 299, 300, 301, 302, 303, 304, 305, 306, 307, 308, 309, 310, 311, 312, 313, 314, 315, 316, 317, 318, 319, 320, 321, 322, 323, 324, 325, 326, 327, 328, 329, 330, 331, 332, 333, 334, 335, 336, 337, 338, 339, 340, 341, 342, 343, 344, 345, 346, 347, 348, 349, 350, 351, 352, 353, 354, 355, 356, 357, 358, 359, 360, 361, 362, 363, 364, 365, 366, 367, 368, 369, 370, 371, 372, 373, 374, 375, 376, 377, 378, 379, 380, 381, 382, 383, 384, 385, 386, 387, 388, 389, 390, 391, 392, 393, 394, 395, 396, 397, 398, 399, 400, 401, 402, 403, 404, 405, 406, 407, 408, 409, 410, 411, 412, 413, 414, 415, 416, 417, 418, 419, 420, 421, 422, 423, 424, 425, 426, 427, 428, 429, 430, 431, 432, 433, 434, 435, 436, 437, 438, 439, 440, 441, 442, 443, 444, 445, 446, 447, 448, 449, 450, 451, 452, 453, 454, 455, 456, 457, 458, 459, 460, 461, 462, 463, 464, 465, 466, 467, 468, 469, 470, 471, 472, 473, 474, 475, 476, 477, 478, 479, 480, 481, 482, 483, 484, 485, 486, 487, 488, 489, 490, 491, 492, 493, 494, 495, 496, 497, 498, 499, 500, 501, 502, 503, 504, 505, 506, 507, 508, 509, 510, 511, 512, 513, 514, 515, 516, 517, 518, 519, 520, 521, 522, 523, 524, 525, 526, 527, 528, 529, 530, 531, 532, 533, 534, 535, 536, 537, 538, 539, 540, 541, 542, 543, 544, 545, 546, 547, 548, 549, 550, 551, 552, 553, 554, 555, 556, 557, 558, 559, 560, 561, 562, 563, 564, 565, 566, 567, 568, 569, 570, 571, 572, 573, 574, 575, 576, 577, 578, 579, 580, 581, 582, 583, 584, 585, 586, 587, 588, 589, 590, 591, 592, 593, 594, 595, 596, 597, 598, 599, 600, 601, 602, 603, 604, 605, 606, 607, 608, 609, 610, 611, 612, 613, 614, 615, 616, 617, 618, 619, 620, 621, 622, 623, 624, 625, 626, 627, 628, 629, 630, 631, 632, 633, 634, 635, 636, 637, 638, 639, 640, 641, 642, 643, 644, 645, 646, 647, 648, 649, 650, 651, 652, 653, 654, 655, 656, 657, 658, 659, 660, 661, 662, 663, 664, 665, 666, 667, 668, 669, 670, 671, 672, 673, 674, 675, 676, 677, 678, 679, 680, 681, 682, 683, 684, 685, 686, 687, 688, 689, 690, 691, 692, 693, 694, 695, 696, 697, 698, 699, 700, 701, 702, 703, 704, 705, 706, 707, 708, 709, 710, 711, 712, 713, 714, 715, 716, 717, 718, 719, 720, 721, 722, 723, 724, 725, 726, 727, 728, 729, 730, 731, 732, 733, 734, 735, 736, 737, 738, 739, 740, 741, 742, 743, 744, 745, 746, 747, 748, 749, 750, 751, 752, 753, 754, 755, 756, 757, 758, 759, 760, 761, 762, 763, 764, 765, 766, 767, 768, 769, 770, 771, 772, 773, 774, 775, 776, 777, 778, 779, 780, 781, 782, 783, 784, 785, 786, 787, 788, 789, 790, 791, 792, 793, 794, 795, 796, 797, 798, 799, 800, 801, 802, 803, 804, 805, 806, 807, 808, 809, 810, 811, 812, 813, 814, 815, 816, 817, 818, 819, 820, 821, 822, 823, 824, 825, 826, 827, 828, 829, 830, 831, 832, 833, 834, 835, 836, 837, 838, 839, 840, 841, 842, 843, 844, 845, 846, 847, 848, 849, 850, 851, 852, 853, 854, 855, 856, 857, 858, 859, 860, 861, 862, 863, 864, 865, 866, 867, 868, 869, 870, 871, 872, 873, 874, 875, 876, 877, 878, 879, 880, 881, 882, 883, 884, 885, 886, 887, 888, 889, 890, 891, 892, 893, 894, 895, 896, 897, 898, 899, 900, 901, 902, 903, 904, 905, 906, 907, 908, 909, 910, 911, 912, 913, 914, 915, 916, 917, 918, 919, 920, 921, 922, 923, 924, 925, 926, 927, 928, 929, 930, 931, 932, 933, 934, 935, 936, 937, 938, 939, 940, 941, 942, 943, 944, 945, 946, 947, 948, 949, 950, 951, 952, 953, 954, 955, 956, 957, 958, 959, 960, 961, 962, 963, 964, 965, 966, 967, 968, 969, 970, 971, 972, 973, 974, 975, 976, 977, 978, 979, 980, 981, 982, 983, 984, 985, 986, 987, 988, 989, 990, 991, 992, 993, 994, 995, 996, 997, 998, 999, 1000

MAIN CONTRACTOR :
Gammon

STRUCTURAL ENGINEER :
ARUP

FACADE CONSULTANT:
MEINHARDT

NOTE :
 1. ALL DIMENSIONS ARE IN mm.
 2. ALL ELEVATIONS ARE VIEWED FROM OUTSIDE.
 3. ALL DIMENSIONS TO BE VERIFIED ON SITE BEFORE FABRICATION.

LEGEND :
 (X1) --- DETAIL MARK NO.
 (X001) --- REFER SHEET NO.
 1. F.F.L. --- FINISHED FLOOR LEVEL
 2. S.F.L. --- STRUCTURAL FLOOR LEVEL
 3. (R) --- REVERSED DETAIL
 4. (▲) --- FIXING LOCATION
 5. (△) --- FIXING LUG LOCATION
 6. GLASS LEGEND
 GL01 --- 8mm+12mm AIR GAP+10mm THK. I.G.U.
 GL01a --- 8mm+9mm AIR GAP+12mm THK. I.G.U.
 GL03 --- 6mm+12mm AIR GAP+6mm THK. I.G.U.
 GL04 --- 10mm THK. TEMPERED GLASS (PROTECTIVE BARRIER)
 GL05 --- 6mm+12mm AIR GAP+8mm THK. I.G.U.

NO.	DATE	REVISION	BY
A	07/11/2020	REVISION SUBJECT TO ARCH.COMMENT	lvart

JOB NO. : J-852
 PROJECT :
 PROPOSED RESIDENTIAL DEVELOPMENT
 AT 139 - 147 ARGYLE STREET,
 NKIL 6005, 6035 R.P., 6036 R.P.,
 6037 R.P. & 6038 R.P.

TITLE :
 SCHEDULE FOR Plenum Box
 AT TOWER 1 (1-21F)

DATE : 05-Dec-19 SCALE : 1:40
 DRAWN BY : MN CHECKED BY : DW

美特鋁質有限公司
MIDI ALUMINIUM FABRICATOR LTD.
 Units 6-8, Sunray Industrial Centre, 1/F
 610 Cha Kwo Ling Road, Kowloon
 Tel:23489211-4 Fax:(852)2727666
 DWG NO. : J852-SD-PB-4102 REV. : A

ELEVATION

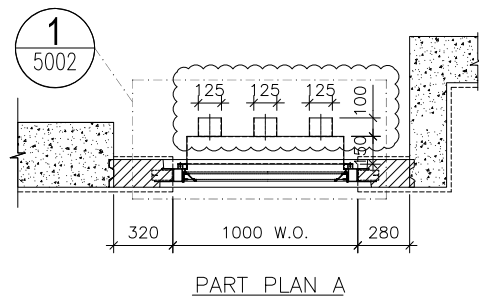
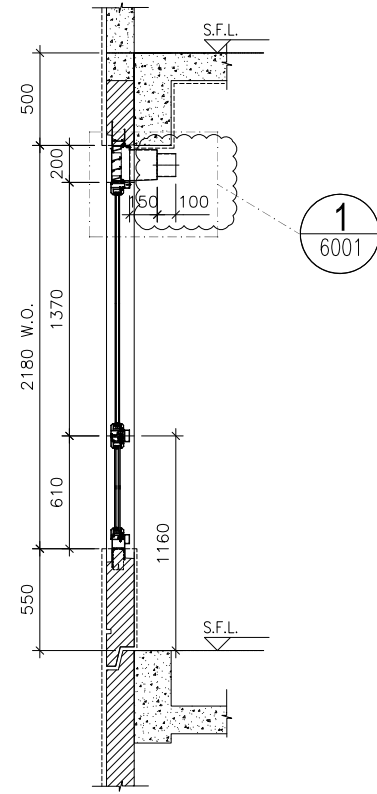
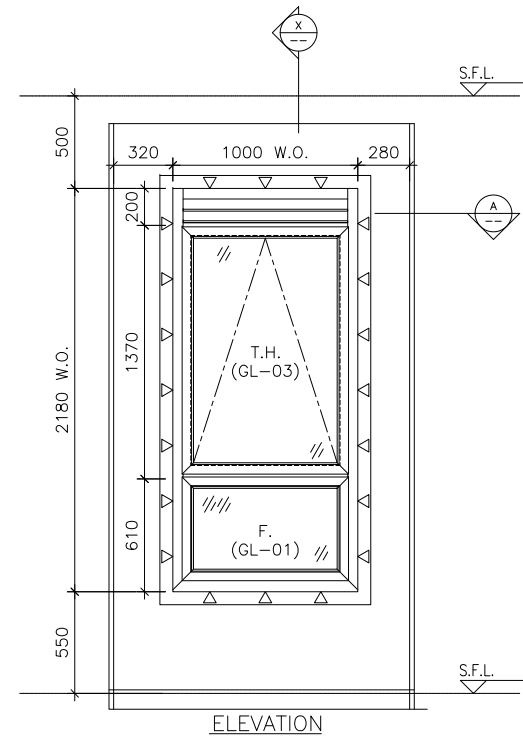

SECTION "X-X"

PART PLAN A

WINDOW MARK



LOCATION 21/F EN.B. AT TOWER 1 FLAT A

SECTION 70mm ALUM. SECTION

GLAZING GL-01, GL-03

QUANTITY 1

REMARKS FACADE (PF-16)

B.D. REF :

CLIENT :

ARCHITECT :



MAIN CONTRACTOR :



STRUCTURAL ENGINEER :



FACADE CONSULTANT:



NOTE :

1. ALL DIMENSIONS ARE IN mm.
2. ALL ELEVATIONS ARE VIEWED FROM OUTSIDE.
3. ALL DIMENSIONS TO BE VERIFIED ON SITE BEFORE FABRICATION.

LEGEND :

- (x1) --- DETAIL MARK NO.
- (x001) --- REFER SHEET NO.

1. F.F.L. -- FINISHED FLOOR LEVEL
2. S.F.L. -- STRUCTURAL FLOOR LEVEL
3. (R) -- REVERSED DETAIL
4. ▲ -- FIXING LOCATION
5. △ -- FIXING LUG LOCATION

6. GLASS LEGEND

- GL01 -- 8mm+12mm AIR GAP+10mm THK. I.G.U.
- GL01a -- 8mm+9mm AIR GAP+12mm THK. I.G.U.
- GL03 -- 6mm+12mm AIR GAP+6mm THK. I.G.U.
- GL04 -- 10mm THK. TEMPERED GLASS (PROTECTIVE BARRIER)
- GL05 -- 6mm+12mm AIR GAP+8mm THK. I.G.U.

NO.	DATE	REVISION	BY
A	07/11/2020	REVISION SUBJECT TO ARCH.COMMENT	lvart

JOB NO. : J-852

PROJECT :
PROPOSED RESIDENTIAL DEVELOPMENT
AT 139 - 147 ARGYLE STREET,
NKIL 6005, 6035 R.P., 6036 R.P.,
6037 R.P. & 6038 R.P.

TITLE :
SCHEDULE FOR Plenum Box
AT TOWER 1 (1-21F)

DATE : 22-Apr-20 SCALE : 1:40

DRAWN BY : MN CHECKED BY : DW

美特鋁質有限公司
MIDI ALUMINIUM FABRICATOR LTD.
Units 6-8, Sunray Industrial Centre, 1/F
610 Cha Kwo Ling Road, Kowloon
Tel:23489211-4 Fax:(852)2727666

DWG NO. : J852-SD-PB-4102A REV. : A

ELEVATION

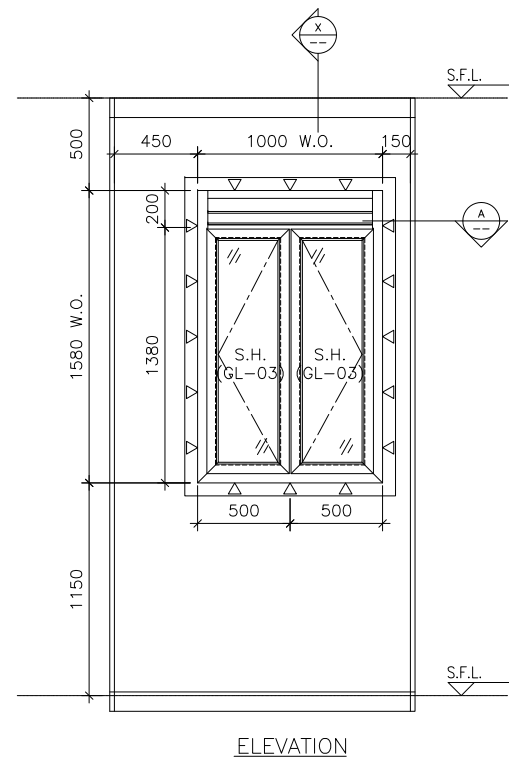

ELEVATION

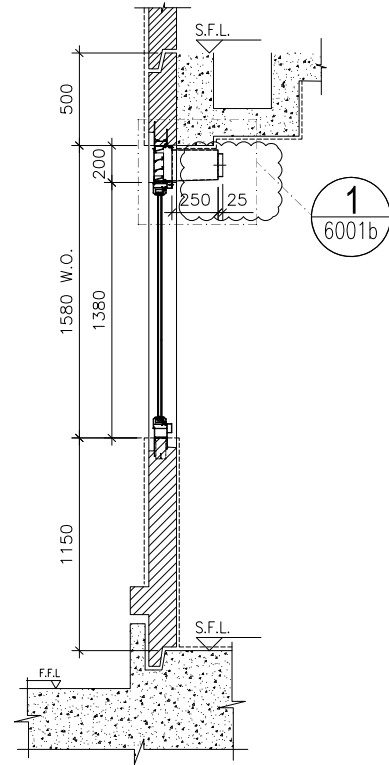

SECTION "X-X"

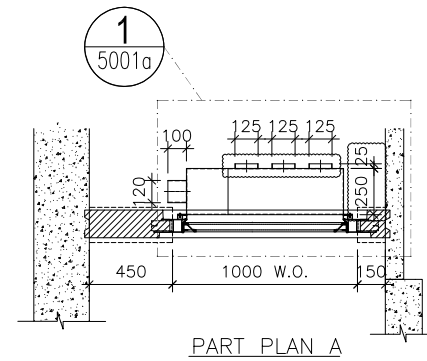

PART PLAN A

WINDOW MARK



LOCATION 1/F KIT. AT TOWER 1 FLAT C

SECTION 70mm ALUM. SECTION

GLAZING GL-03

QUANTITY 1

REMARKS FACADE (PF-31)

B.D. REF :

CLIENT :

ARCHITECT :

AGC
DESIGN LTD

MAIN CONTRACTOR :

Gammon

STRUCTURAL ENGINEER :

ARUP

FACADE CONSULTANT:

MEINHARDT

NOTE :

1. ALL DIMENSIONS ARE IN mm.
2. ALL ELEVATIONS ARE VIEWED FROM OUTSIDE.
3. ALL DIMENSIONS TO BE VERIFIED ON SITE BEFORE FABRICATION.

LEGEND :

- (X1) --- DETAIL MARK NO.
- (X001) --- REFER SHEET NO.

1. F.F.L. --- FINISHED FLOOR LEVEL
2. S.F.L. --- STRUCTURAL FLOOR LEVEL
3. (R) --- REVERSED DETAIL
4. ▲ --- FIXING LOCATION
5. △ --- FIXING LUG LOCATION

6. GLASS LEGEND

- GL01 --- 8mm+12mm AIR GAP+10mm THK. I.G.U.
- GL01a --- 8mm+9mm AIR GAP+12mm THK. I.G.U.
- GL03 --- 6mm+12mm AIR GAP+6mm THK. I.G.U.
- GL04 --- 10mm THK. TEMPERED GLASS (PROTECTIVE BARRIER)
- GL05 --- 6mm+12mm AIR GAP+8mm THK. I.G.U.

B	05/03/2021	REVISION SUBJECT TO ARCH.COMMENT	Ivan
A	09/12/2020	REVISION SUBJECT TO ARCH.COMMENT	Ivan
NO.	DATE	REVISED	BY

JOB NO. : J-852

PROJECT :
PROPOSED RESIDENTIAL DEVELOPMENT
AT 139 - 147 ARGYLE STREET,
NKIL 6005, 6035 R.P., 6036 R.P.,
6037 R.P. & 6038 R.P.

TITLE :
SCHEDULE FOR Plenum Box
AT TOWER 1 (1-21F)

DATE : 22-Apr-20 SCALE : 1:40

DRAWN BY : MN CHECKED BY : DW

美特鋁質有限公司
MIDI ALUMINIUM FABRICATOR LTD.
Units 6-8, Sunray Industrial Centre, 1/F
610 Cha Kwo Ling Road, Kowloon
Tel:23489211-4 Fax:(852)2727666

DWG NO. : J852-SD-PB-4103 REV. : B

ELEVATION

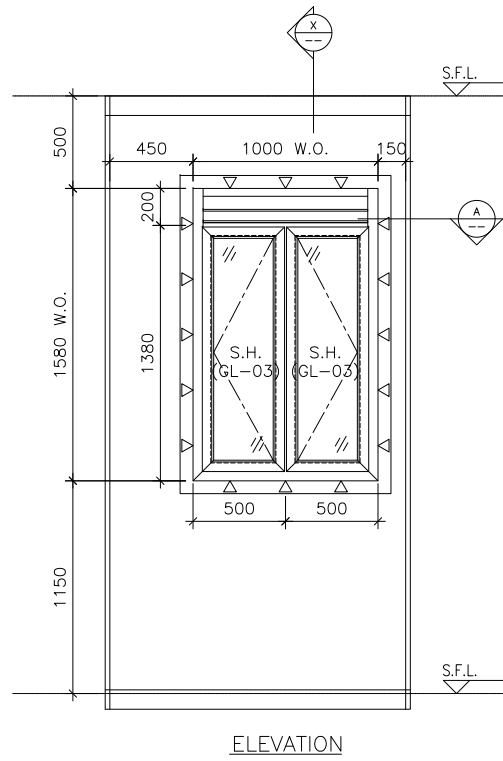

ELEVATION

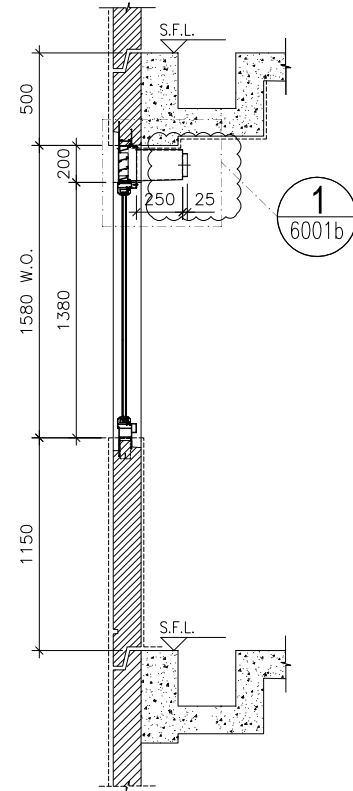

SECTION "X-X"

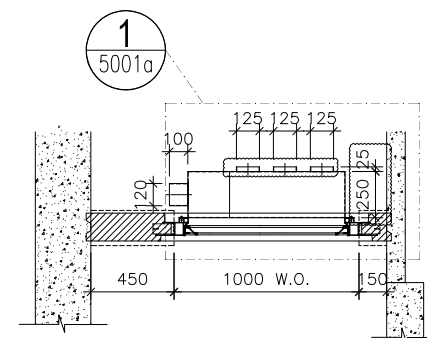

PART PLAN A

WINDOW MARK



LOCATION 2/F-21/F KIT. AT TOWER 1 FLAT C

SECTION 70mm ALUM. SECTION

GLAZING GL-03

QUANTITY 17

REMARKS FACADE (PF-31)

B.D. REF :

CLIENT :

ARCHITECT :

AGC
DESIGN LTD

MAIN CONTRACTOR :

Gammon

STRUCTURAL ENGINEER :

ARUP

FACADE CONSULTANT:

MEINHARDT

NOTE :

1. ALL DIMENSIONS ARE IN mm.
2. ALL ELEVATIONS ARE VIEWED FROM OUTSIDE.
3. ALL DIMENSIONS TO BE VERIFIED ON SITE BEFORE FABRICATION.

LEGEND :

- (x1) --- DETAIL MARK NO.
- (x001) --- REFER SHEET NO.

1. F.F.L. --- FINISHED FLOOR LEVEL
2. S.F.L. --- STRUCTURAL FLOOR LEVEL
3. (R) --- REVERSED DETAIL
4. ▲ --- FIXING LOCATION
5. △ --- FIXING LUG LOCATION

6. GLASS LEGEND

- GL01 --- 8mm+12mm AIR GAP+10mm THK. I.G.U.
- GL01a --- 8mm+9mm AIR GAP+12mm THK. I.G.U.
- GL03 --- 6mm+12mm AIR GAP+6mm THK. I.G.U.
- GL04 --- 10mm THK. TEMPERED GLASS (PROTECTIVE BARRIER)
- GL05 --- 6mm+12mm AIR GAP+8mm THK. I.G.U.

B	05/03/2021	REVISION SUBJECT TO ARCH.COMMENT	Ivan
A	09/12/2020	REVISION SUBJECT TO ARCH.COMMENT	Ivan
NO.	DATE	REVISED	BY

JOB NO. : J-852

PROJECT :
PROPOSED RESIDENTIAL DEVELOPMENT
AT 139 - 147 ARGYLE STREET,
NKIL 6005, 6035 R.P., 6036 R.P.,
6037 R.P. & 6038 R.P.

TITLE :
SCHEDULE FOR Plenum Box
AT TOWER 1 (1-21F)

DATE : 05-Dec-19 SCALE : 1:40

DRAWN BY : MN CHECKED BY : DW

美特鋁質有限公司
MIDI ALUMINIUM FABRICATOR LTD.
Units 6-8, Sunray Industrial Centre, 1/F
610 Cha Kwo Ling Road, Kowloon
Tel:23489211-4 Fax:(852)2727666

DWG NO. : J852-SD-PB-4103A REV. : B

ELEVATION

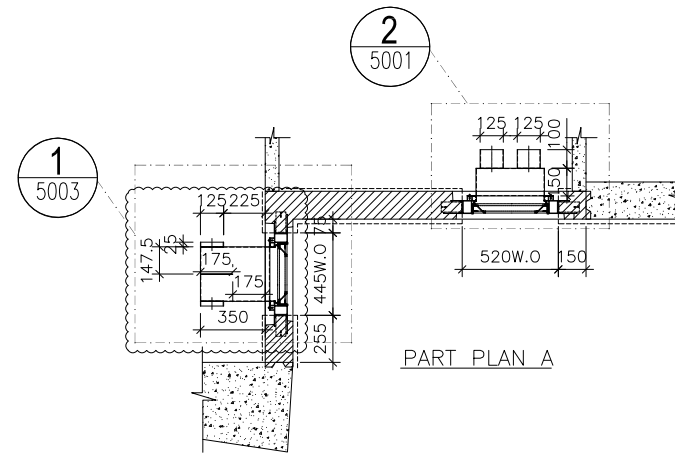
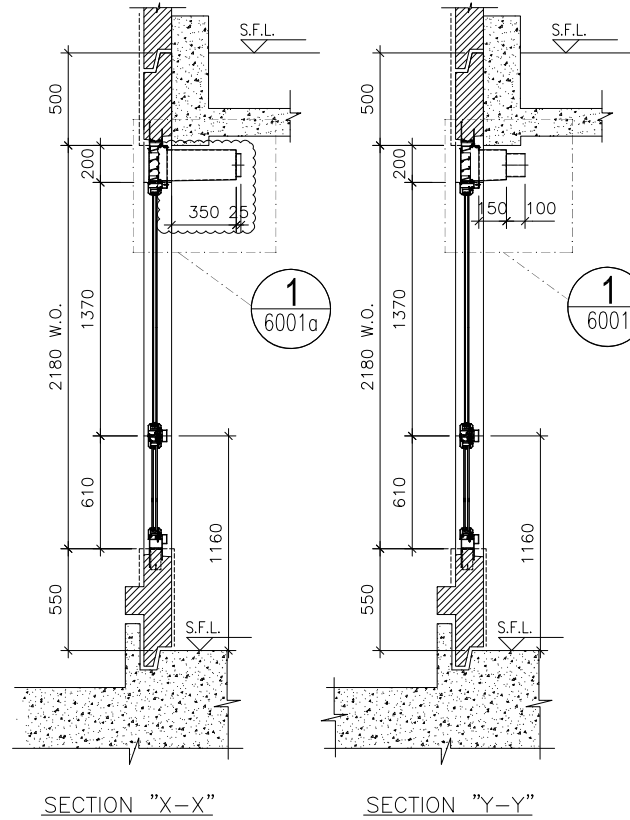
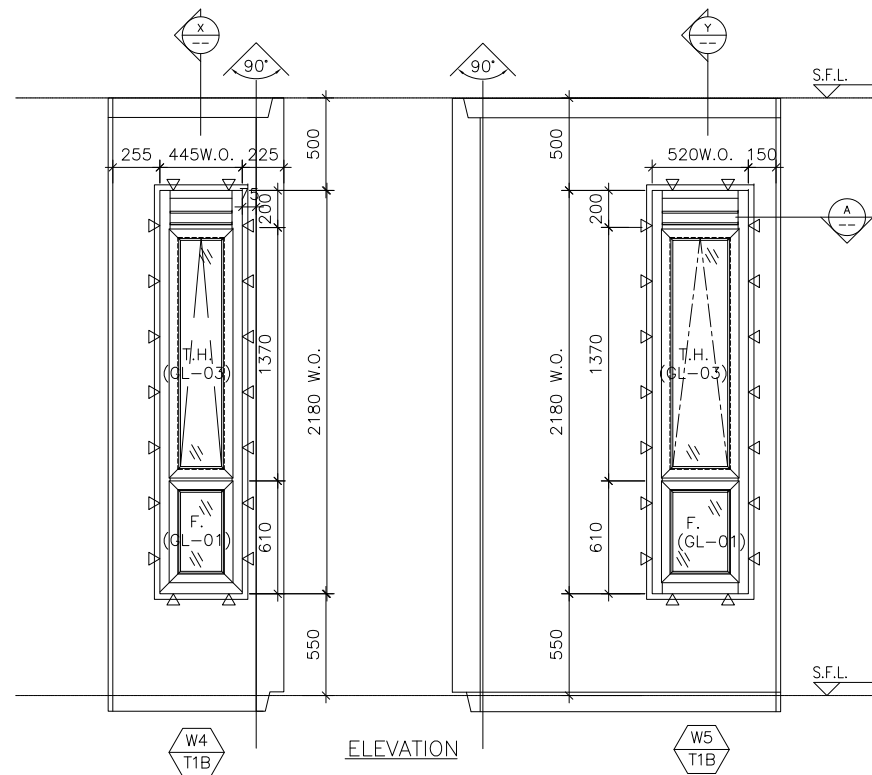

WINDOW MARK W5
T1B / W4
T1B

LOCATION 1/F M.B. & EN.B. AT TOWER 1 FLAT B

SECTION 70mm ALUM. SECTION

GLAZING GL-01, GL-03

QUANTITY 1 / 1

REMARKS FACADE (PF-37)

B.D. REF :

CLIENT :

ARCHITECT :
AGC DESIGN LTD
AGC DESIGN LTD
101, 102, 103, 104, 105, 106, 107, 108, 109, 110, 111, 112, 113, 114, 115, 116, 117, 118, 119, 120, 121, 122, 123, 124, 125, 126, 127, 128, 129, 130, 131, 132, 133, 134, 135, 136, 137, 138, 139, 140, 141, 142, 143, 144, 145, 146, 147, 148, 149, 150, 151, 152, 153, 154, 155, 156, 157, 158, 159, 160, 161, 162, 163, 164, 165, 166, 167, 168, 169, 170, 171, 172, 173, 174, 175, 176, 177, 178, 179, 180, 181, 182, 183, 184, 185, 186, 187, 188, 189, 190, 191, 192, 193, 194, 195, 196, 197, 198, 199, 200, 201, 202, 203, 204, 205, 206, 207, 208, 209, 210, 211, 212, 213, 214, 215, 216, 217, 218, 219, 220, 221, 222, 223, 224, 225, 226, 227, 228, 229, 230, 231, 232, 233, 234, 235, 236, 237, 238, 239, 240, 241, 242, 243, 244, 245, 246, 247, 248, 249, 250, 251, 252, 253, 254, 255, 256, 257, 258, 259, 260, 261, 262, 263, 264, 265, 266, 267, 268, 269, 270, 271, 272, 273, 274, 275, 276, 277, 278, 279, 280, 281, 282, 283, 284, 285, 286, 287, 288, 289, 290, 291, 292, 293, 294, 295, 296, 297, 298, 299, 300, 301, 302, 303, 304, 305, 306, 307, 308, 309, 310, 311, 312, 313, 314, 315, 316, 317, 318, 319, 320, 321, 322, 323, 324, 325, 326, 327, 328, 329, 330, 331, 332, 333, 334, 335, 336, 337, 338, 339, 340, 341, 342, 343, 344, 345, 346, 347, 348, 349, 350, 351, 352, 353, 354, 355, 356, 357, 358, 359, 360, 361, 362, 363, 364, 365, 366, 367, 368, 369, 370, 371, 372, 373, 374, 375, 376, 377, 378, 379, 380, 381, 382, 383, 384, 385, 386, 387, 388, 389, 390, 391, 392, 393, 394, 395, 396, 397, 398, 399, 400, 401, 402, 403, 404, 405, 406, 407, 408, 409, 410, 411, 412, 413, 414, 415, 416, 417, 418, 419, 420, 421, 422, 423, 424, 425, 426, 427, 428, 429, 430, 431, 432, 433, 434, 435, 436, 437, 438, 439, 440, 441, 442, 443, 444, 445, 446, 447, 448, 449, 450, 451, 452, 453, 454, 455, 456, 457, 458, 459, 460, 461, 462, 463, 464, 465, 466, 467, 468, 469, 470, 471, 472, 473, 474, 475, 476, 477, 478, 479, 480, 481, 482, 483, 484, 485, 486, 487, 488, 489, 490, 491, 492, 493, 494, 495, 496, 497, 498, 499, 500, 501, 502, 503, 504, 505, 506, 507, 508, 509, 510, 511, 512, 513, 514, 515, 516, 517, 518, 519, 520, 521, 522, 523, 524, 525, 526, 527, 528, 529, 530, 531, 532, 533, 534, 535, 536, 537, 538, 539, 540, 541, 542, 543, 544, 545, 546, 547, 548, 549, 550, 551, 552, 553, 554, 555, 556, 557, 558, 559, 560, 561, 562, 563, 564, 565, 566, 567, 568, 569, 570, 571, 572, 573, 574, 575, 576, 577, 578, 579, 580, 581, 582, 583, 584, 585, 586, 587, 588, 589, 590, 591, 592, 593, 594, 595, 596, 597, 598, 599, 600, 601, 602, 603, 604, 605, 606, 607, 608, 609, 610, 611, 612, 613, 614, 615, 616, 617, 618, 619, 620, 621, 622, 623, 624, 625, 626, 627, 628, 629, 630, 631, 632, 633, 634, 635, 636, 637, 638, 639, 640, 641, 642, 643, 644, 645, 646, 647, 648, 649, 650, 651, 652, 653, 654, 655, 656, 657, 658, 659, 660, 661, 662, 663, 664, 665, 666, 667, 668, 669, 670, 671, 672, 673, 674, 675, 676, 677, 678, 679, 680, 681, 682, 683, 684, 685, 686, 687, 688, 689, 690, 691, 692, 693, 694, 695, 696, 697, 698, 699, 700, 701, 702, 703, 704, 705, 706, 707, 708, 709, 710, 711, 712, 713, 714, 715, 716, 717, 718, 719, 720, 721, 722, 723, 724, 725, 726, 727, 728, 729, 730, 731, 732, 733, 734, 735, 736, 737, 738, 739, 740, 741, 742, 743, 744, 745, 746, 747, 748, 749, 750, 751, 752, 753, 754, 755, 756, 757, 758, 759, 760, 761, 762, 763, 764, 765, 766, 767, 768, 769, 770, 771, 772, 773, 774, 775, 776, 777, 778, 779, 780, 781, 782, 783, 784, 785, 786, 787, 788, 789, 790, 791, 792, 793, 794, 795, 796, 797, 798, 799, 800, 801, 802, 803, 804, 805, 806, 807, 808, 809, 810, 811, 812, 813, 814, 815, 816, 817, 818, 819, 820, 821, 822, 823, 824, 825, 826, 827, 828, 829, 830, 831, 832, 833, 834, 835, 836, 837, 838, 839, 840, 841, 842, 843, 844, 845, 846, 847, 848, 849, 850, 851, 852, 853, 854, 855, 856, 857, 858, 859, 860, 861, 862, 863, 864, 865, 866, 867, 868, 869, 870, 871, 872, 873, 874, 875, 876, 877, 878, 879, 880, 881, 882, 883, 884, 885, 886, 887, 888, 889, 890, 891, 892, 893, 894, 895, 896, 897, 898, 899, 900, 901, 902, 903, 904, 905, 906, 907, 908, 909, 910, 911, 912, 913, 914, 915, 916, 917, 918, 919, 920, 921, 922, 923, 924, 925, 926, 927, 928, 929, 930, 931, 932, 933, 934, 935, 936, 937, 938, 939, 940, 941, 942, 943, 944, 945, 946, 947, 948, 949, 950, 951, 952, 953, 954, 955, 956, 957, 958, 959, 960, 961, 962, 963, 964, 965, 966, 967, 968, 969, 970, 971, 972, 973, 974, 975, 976, 977, 978, 979, 980, 981, 982, 983, 984, 985, 986, 987, 988, 989, 990, 991, 992, 993, 994, 995, 996, 997, 998, 999, 1000

MAIN CONTRACTOR :
Gammon

STRUCTURAL ENGINEER :
ARUP

FACADE CONSULTANT:
MEINHARDT

NOTE :
1. ALL DIMENSIONS ARE IN mm.
2. ALL ELEVATIONS ARE VIEWED FROM OUTSIDE.
3. ALL DIMENSIONS TO BE VERIFIED ON SITE BEFORE FABRICATION.

LEGEND :
x1 --- DETAIL MARK NO.
x001 --- REFER SHEET NO.
1. F.F.L. --- FINISHED FLOOR LEVEL
2. S.F.L. --- STRUCTURAL FLOOR LEVEL
3. (R) --- REVERSED DETAIL
4. ▲ --- FIXING LOCATION
5. △ --- FIXING LUG LOCATION
6. GLASS LEGEND
GL01 --- 8mm+12mm AIR GAP+10mm THK. I.G.U.
GL01a --- 8mm+9mm AIR GAP+12mm THK. I.G.U.
GL03 --- 6mm+12mm AIR GAP+6mm THK. I.G.U.
GL04 --- 10mm THK. TEMPERED GLASS (PROTECTIVE BARRIER)
GL05 --- 6mm+12mm AIR GAP+8mm THK. I.G.U.

C	22/03/2021	REVISION SUBJECT TO ARCH.COMMENT	Ivan
B	06/01/2021	REVISION SUBJECT TO ARCH.COMMENT	Ivan
A	07/11/2020	REVISION SUBJECT TO ARCH.COMMENT	Ivan
NO.	DATE	REVISED	BY

JOB NO. : J-852
PROJECT : PROPOSED RESIDENTIAL DEVELOPMENT AT 139 - 147 ARGYLE STREET, NKIL 6005, 6035 R.P., 6036 R.P., 6037 R.P. & 6038 R.P.
TITLE : SCHEDULE FOR Plenum Box AT TOWER 1 (1-21F)

DATE : 22-Apr-20 SCALE : 1:40
DRAWN BY : MN CHECKED BY : DW

美特鋁質有限公司
MIDI ALUMINIUM FABRICATOR LTD.
Units 6-8, Sunray Industrial Centre, 1/F
610 Cha Kwo Ling Road, Kowloon
Tel:23489211-4 Fax:(852)2727666
DWG NO. : J852-SD-PB-4104 REV. : C

ELEVATION

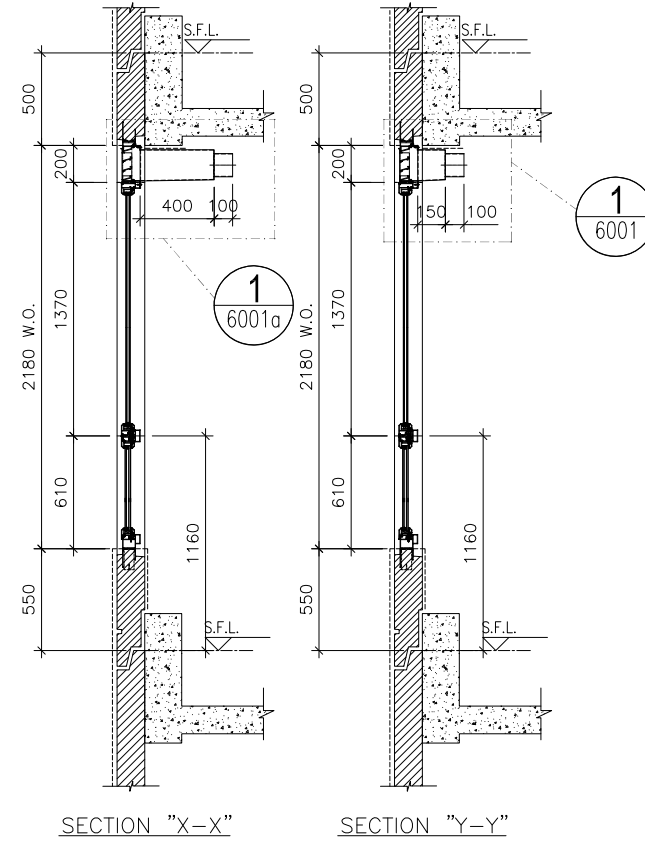
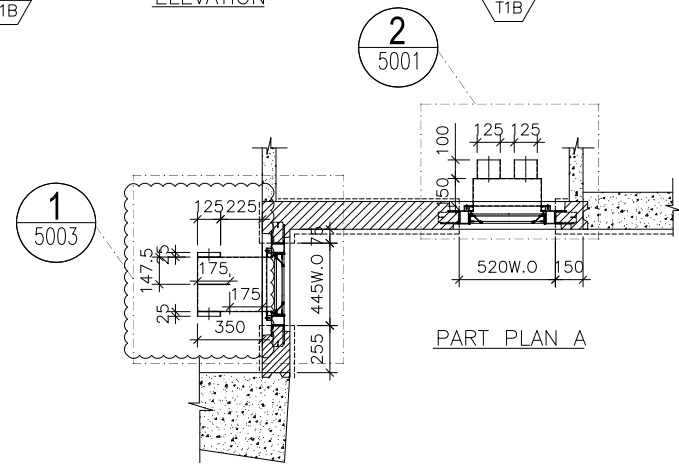
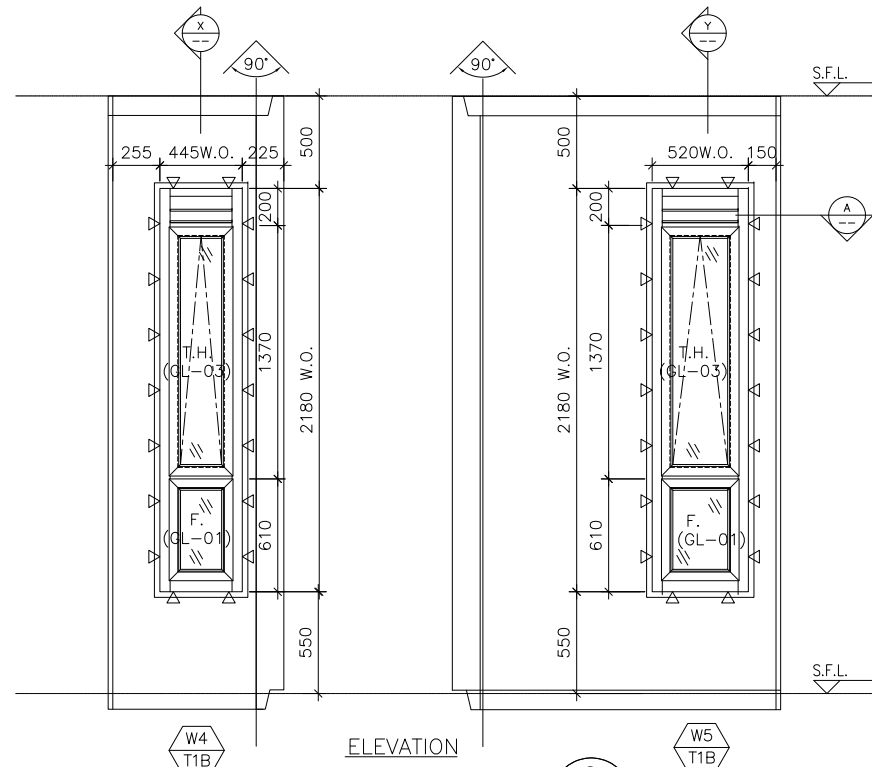

WINDOW MARK



LOCATION 2/F~21/F M.B. & EN.B. AT TOWER 1 FLAT B

SECTION 70mm ALUM. SECTION

GLAZING GL-01, GL-03

QUANTITY 17 / 17

REMARKS FACADE (PF-37)

B.D. REF :

CLIENT :

ARCHITECT :



MAIN CONTRACTOR :



STRUCTURAL ENGINEER :



FACADE CONSULTANT:



NOTE :

1. ALL DIMENSIONS ARE IN mm.
2. ALL ELEVATIONS ARE VIEWED FROM OUTSIDE.
3. ALL DIMENSIONS TO BE VERIFIED ON SITE BEFORE FABRICATION.

LEGEND :

- (X1) --- DETAIL MARK NO.
- (X001) --- REFER SHEET NO.

1. F.F.L. -- FINISHED FLOOR LEVEL
2. S.F.L. -- STRUCTURAL FLOOR LEVEL
3. (R) -- REVERSED DETAIL
4. ▲ -- FIXING LOCATION
5. △ -- FIXING LUG LOCATION

6. GLASS LEGEND
- GL01 -- 8mm+12mm AIR GAP+10mm THK. I.G.U.
 - GL01a -- 8mm+9mm AIR GAP+12mm THK. I.G.U.
 - GL03 -- 6mm+12mm AIR GAP+6mm THK. I.G.U.
 - GL04 -- 10mm THK. TEMPERED GLASS (PROTECTIVE BARRIER)
 - GL05 -- 6mm+12mm AIR GAP+8mm THK. I.G.U.

NO.	DATE	REVISION	BY
C	22/03/2021	REVISION SUBJECT TO ARCH.COMMENT	Ivan
B	06/01/2021	REVISION SUBJECT TO ARCH.COMMENT	Ivan
A	07/11/2020	REVISION SUBJECT TO ARCH.COMMENT	Ivan

JOB NO. : J-852
 PROJECT : PROPOSED RESIDENTIAL DEVELOPMENT AT 139 - 147 ARGYLE STREET, NKIL 6005, 6035 R.P., 6036 R.P., 6037 R.P. & 6038 R.P.

TITLE : SCHEDULE FOR Plenum Box AT TOWER 1 (1-21F)

DATE : 22-Apr-20 SCALE : 1:40

DRAWN BY : MN CHECKED BY : DW

美特鋁質有限公司
 MIDI ALUMINIUM FABRICATOR LTD.
 Units 6-8, Sunray Industrial Centre, 1/F
 610 Cha Kwo Ling Road, Kowloon
 Tel:23489211-4 Fax:(852)2727666

DWG NO. : J852-SD-PB-4104A REV. : C

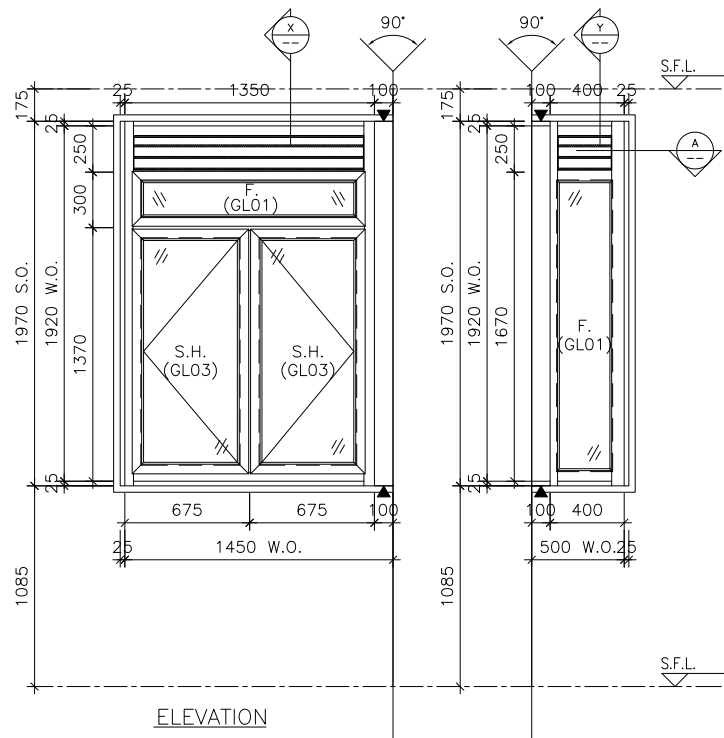

ELEVATION

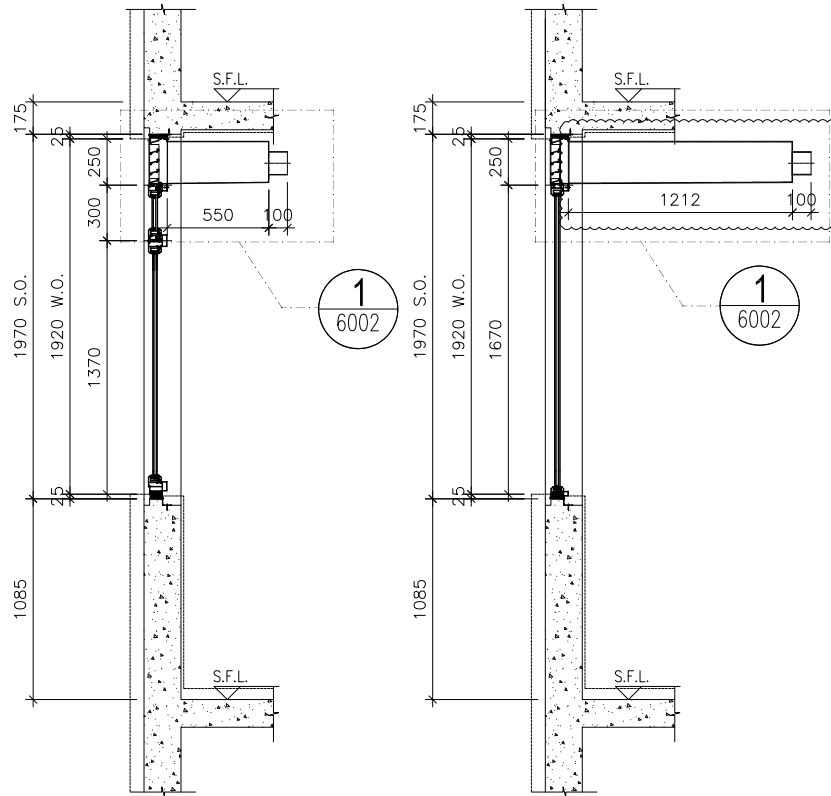

SECTION "X-X"

SECTION "Y-Y"

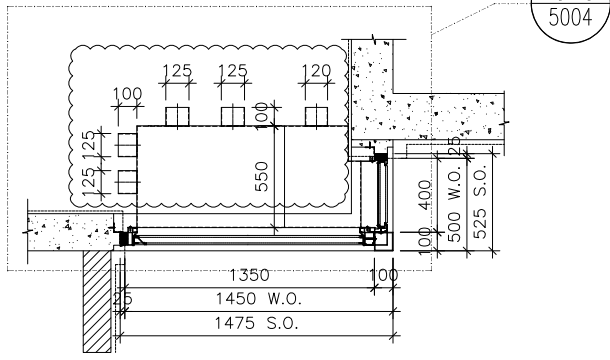

PART PLAN A

ELEVATION

WINDOW MARK



LOCATION 1/F~21/F KIT. AT TOWER 1 FLAT B

SECTION 50mm ALUM. SECTION

GLAZING GL01, GL03

QUANTITY 18

REMARKS

B.D. REF :

CLIENT :

ARCHITECT :
AGC DESIGN LTD
 101, 102, 103, 104, 105, 106, 107, 108, 109, 110, 111, 112, 113, 114, 115, 116, 117, 118, 119, 120, 121, 122, 123, 124, 125, 126, 127, 128, 129, 130, 131, 132, 133, 134, 135, 136, 137, 138, 139, 140, 141, 142, 143, 144, 145, 146, 147, 148, 149, 150, 151, 152, 153, 154, 155, 156, 157, 158, 159, 160, 161, 162, 163, 164, 165, 166, 167, 168, 169, 170, 171, 172, 173, 174, 175, 176, 177, 178, 179, 180, 181, 182, 183, 184, 185, 186, 187, 188, 189, 190, 191, 192, 193, 194, 195, 196, 197, 198, 199, 200, 201, 202, 203, 204, 205, 206, 207, 208, 209, 210, 211, 212, 213, 214, 215, 216, 217, 218, 219, 220, 221, 222, 223, 224, 225, 226, 227, 228, 229, 230, 231, 232, 233, 234, 235, 236, 237, 238, 239, 240, 241, 242, 243, 244, 245, 246, 247, 248, 249, 250, 251, 252, 253, 254, 255, 256, 257, 258, 259, 260, 261, 262, 263, 264, 265, 266, 267, 268, 269, 270, 271, 272, 273, 274, 275, 276, 277, 278, 279, 280, 281, 282, 283, 284, 285, 286, 287, 288, 289, 290, 291, 292, 293, 294, 295, 296, 297, 298, 299, 300, 301, 302, 303, 304, 305, 306, 307, 308, 309, 310, 311, 312, 313, 314, 315, 316, 317, 318, 319, 320, 321, 322, 323, 324, 325, 326, 327, 328, 329, 330, 331, 332, 333, 334, 335, 336, 337, 338, 339, 340, 341, 342, 343, 344, 345, 346, 347, 348, 349, 350, 351, 352, 353, 354, 355, 356, 357, 358, 359, 360, 361, 362, 363, 364, 365, 366, 367, 368, 369, 370, 371, 372, 373, 374, 375, 376, 377, 378, 379, 380, 381, 382, 383, 384, 385, 386, 387, 388, 389, 390, 391, 392, 393, 394, 395, 396, 397, 398, 399, 400, 401, 402, 403, 404, 405, 406, 407, 408, 409, 410, 411, 412, 413, 414, 415, 416, 417, 418, 419, 420, 421, 422, 423, 424, 425, 426, 427, 428, 429, 430, 431, 432, 433, 434, 435, 436, 437, 438, 439, 440, 441, 442, 443, 444, 445, 446, 447, 448, 449, 450, 451, 452, 453, 454, 455, 456, 457, 458, 459, 460, 461, 462, 463, 464, 465, 466, 467, 468, 469, 470, 471, 472, 473, 474, 475, 476, 477, 478, 479, 480, 481, 482, 483, 484, 485, 486, 487, 488, 489, 490, 491, 492, 493, 494, 495, 496, 497, 498, 499, 500, 501, 502, 503, 504, 505, 506, 507, 508, 509, 510, 511, 512, 513, 514, 515, 516, 517, 518, 519, 520, 521, 522, 523, 524, 525, 526, 527, 528, 529, 530, 531, 532, 533, 534, 535, 536, 537, 538, 539, 540, 541, 542, 543, 544, 545, 546, 547, 548, 549, 550, 551, 552, 553, 554, 555, 556, 557, 558, 559, 560, 561, 562, 563, 564, 565, 566, 567, 568, 569, 570, 571, 572, 573, 574, 575, 576, 577, 578, 579, 580, 581, 582, 583, 584, 585, 586, 587, 588, 589, 590, 591, 592, 593, 594, 595, 596, 597, 598, 599, 600, 601, 602, 603, 604, 605, 606, 607, 608, 609, 610, 611, 612, 613, 614, 615, 616, 617, 618, 619, 620, 621, 622, 623, 624, 625, 626, 627, 628, 629, 630, 631, 632, 633, 634, 635, 636, 637, 638, 639, 640, 641, 642, 643, 644, 645, 646, 647, 648, 649, 650, 651, 652, 653, 654, 655, 656, 657, 658, 659, 660, 661, 662, 663, 664, 665, 666, 667, 668, 669, 670, 671, 672, 673, 674, 675, 676, 677, 678, 679, 680, 681, 682, 683, 684, 685, 686, 687, 688, 689, 690, 691, 692, 693, 694, 695, 696, 697, 698, 699, 700, 701, 702, 703, 704, 705, 706, 707, 708, 709, 710, 711, 712, 713, 714, 715, 716, 717, 718, 719, 720, 721, 722, 723, 724, 725, 726, 727, 728, 729, 730, 731, 732, 733, 734, 735, 736, 737, 738, 739, 740, 741, 742, 743, 744, 745, 746, 747, 748, 749, 750, 751, 752, 753, 754, 755, 756, 757, 758, 759, 760, 761, 762, 763, 764, 765, 766, 767, 768, 769, 770, 771, 772, 773, 774, 775, 776, 777, 778, 779, 780, 781, 782, 783, 784, 785, 786, 787, 788, 789, 790, 791, 792, 793, 794, 795, 796, 797, 798, 799, 800, 801, 802, 803, 804, 805, 806, 807, 808, 809, 810, 811, 812, 813, 814, 815, 816, 817, 818, 819, 820, 821, 822, 823, 824, 825, 826, 827, 828, 829, 830, 831, 832, 833, 834, 835, 836, 837, 838, 839, 840, 841, 842, 843, 844, 845, 846, 847, 848, 849, 850, 851, 852, 853, 854, 855, 856, 857, 858, 859, 860, 861, 862, 863, 864, 865, 866, 867, 868, 869, 870, 871, 872, 873, 874, 875, 876, 877, 878, 879, 880, 881, 882, 883, 884, 885, 886, 887, 888, 889, 890, 891, 892, 893, 894, 895, 896, 897, 898, 899, 900, 901, 902, 903, 904, 905, 906, 907, 908, 909, 910, 911, 912, 913, 914, 915, 916, 917, 918, 919, 920, 921, 922, 923, 924, 925, 926, 927, 928, 929, 930, 931, 932, 933, 934, 935, 936, 937, 938, 939, 940, 941, 942, 943, 944, 945, 946, 947, 948, 949, 950, 951, 952, 953, 954, 955, 956, 957, 958, 959, 960, 961, 962, 963, 964, 965, 966, 967, 968, 969, 970, 971, 972, 973, 974, 975, 976, 977, 978, 979, 980, 981, 982, 983, 984, 985, 986, 987, 988, 989, 990, 991, 992, 993, 994, 995, 996, 997, 998, 999, 1000.

MAIN CONTRACTOR :
Gammon

STRUCTURAL ENGINEER :
ARUP

FACADE CONSULTANT:
MEINHARDT

NOTE :
 1. ALL DIMENSIONS ARE IN mm.
 2. ALL ELEVATIONS ARE VIEWED FROM OUTSIDE.
 3. ALL DIMENSIONS TO BE VERIFIED ON SITE BEFORE FABRICATION.

LEGEND :
 (X1) --- DETAIL MARK NO.
 (X001) --- REFER SHEET NO.
 1. F.F.L. --- FINISHED FLOOR LEVEL
 2. S.F.L. --- STRUCTURAL FLOOR LEVEL
 3. (R) --- REVERSED DETAIL
 4. ▲ --- FIXING LOCATION
 5. △ --- FIXING LUG LOCATION
 6. GLASS LEGEND
 GL01 --- 8mm+12mm AIR GAP+10mm THK. I.G.U.
 GL01a --- 8mm+9mm AIR GAP+12mm THK. I.G.U.
 GL03 --- 6mm+12mm AIR GAP+6mm THK. I.G.U.
 GL04 --- 10mm THK. TEMPERED GLASS (PROTECTIVE BARRIER)
 GL05 --- 6mm+12mm AIR GAP+8mm THK. I.G.U.

NO.	DATE	REVISION	BY
A	09/12/2020	REVISION SUBJECT TO ARCH.COMMENT	Ivan

JOB NO. : J-852
 PROJECT :
 PROPOSED RESIDENTIAL DEVELOPMENT
 AT 139 - 147 ARGYLE STREET,
 NKIL 6005, 6035 R.P., 6036 R.P.,
 6037 R.P. & 6038 R.P.

TITLE :
 SCHEDULE FOR Plenum Box
 AT TOWER 1 (1-21F)

DATE : 05-FEB-20 SCALE : 1:100
 DRAWN BY : MN CHECKED BY : DW

美特鋁質有限公司
MIDI ALUMINIUM FABRICATOR LTD.
 Units 6-8, Sunray Industrial Centre, 1/F
 610 Cha Kwo Ling Road, Kowloon
 Tel:23489211-4 Fax:(852)2727666

DWG NO. : J852-SD-PB-4105 REV. : A

ELEVATION

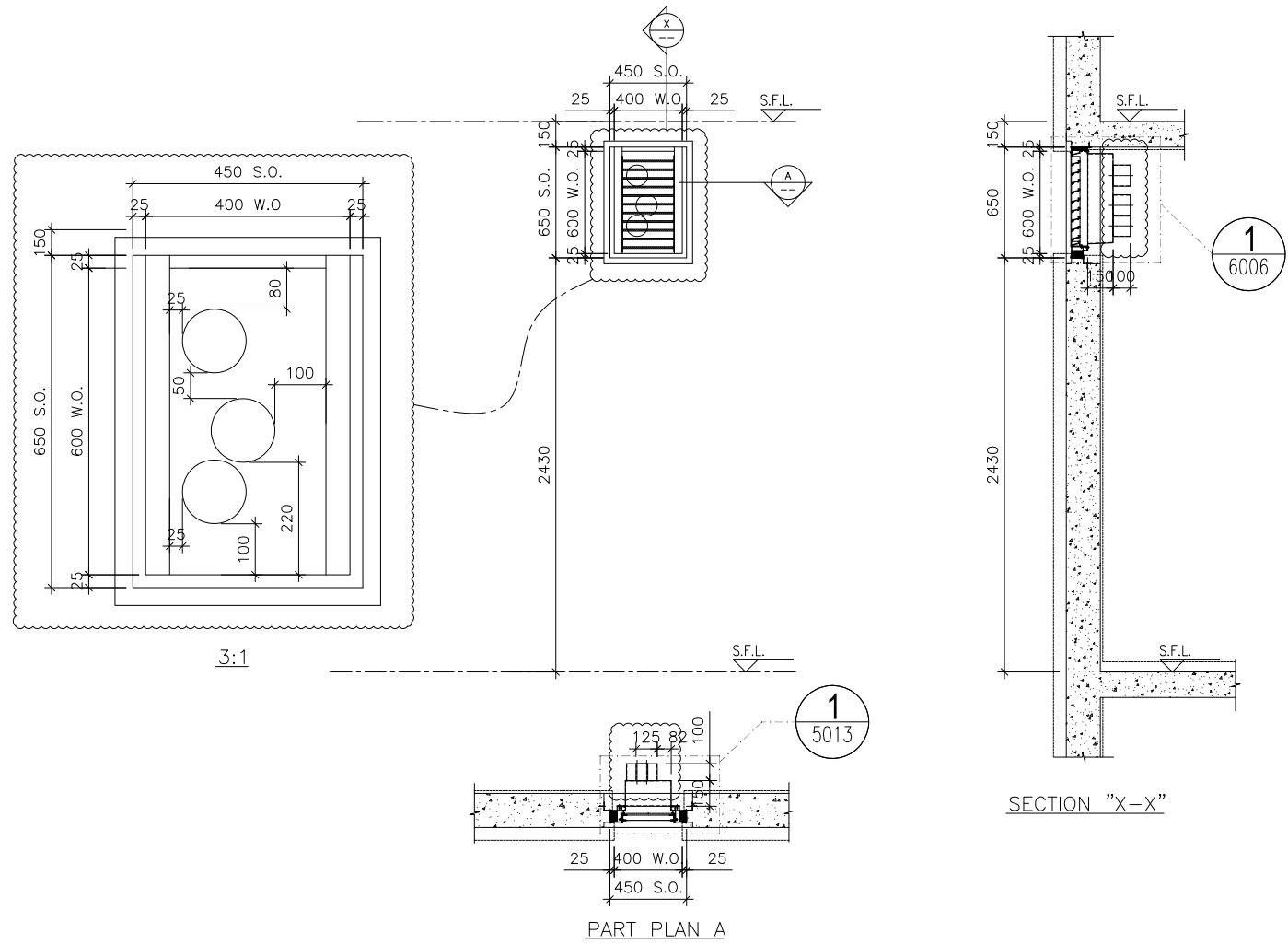

WINDOW MARK



LOCATION 1/F-21/F Corridor AT TOWER 1 FLAT C

SECTION 70mm ALUM. SECTION

GLAZING

QUANTITY 18

REMARKS

B.D. REF :

CLIENT :

ARCHITECT :
AGC DESIGN LTD
 101, 102, 103, 104, 105, 106, 107, 108, 109, 110, 111, 112, 113, 114, 115, 116, 117, 118, 119, 120, 121, 122, 123, 124, 125, 126, 127, 128, 129, 130, 131, 132, 133, 134, 135, 136, 137, 138, 139, 140, 141, 142, 143, 144, 145, 146, 147, 148, 149, 150, 151, 152, 153, 154, 155, 156, 157, 158, 159, 160, 161, 162, 163, 164, 165, 166, 167, 168, 169, 170, 171, 172, 173, 174, 175, 176, 177, 178, 179, 180, 181, 182, 183, 184, 185, 186, 187, 188, 189, 190, 191, 192, 193, 194, 195, 196, 197, 198, 199, 200, 201, 202, 203, 204, 205, 206, 207, 208, 209, 210, 211, 212, 213, 214, 215, 216, 217, 218, 219, 220, 221, 222, 223, 224, 225, 226, 227, 228, 229, 230, 231, 232, 233, 234, 235, 236, 237, 238, 239, 240, 241, 242, 243, 244, 245, 246, 247, 248, 249, 250, 251, 252, 253, 254, 255, 256, 257, 258, 259, 260, 261, 262, 263, 264, 265, 266, 267, 268, 269, 270, 271, 272, 273, 274, 275, 276, 277, 278, 279, 280, 281, 282, 283, 284, 285, 286, 287, 288, 289, 290, 291, 292, 293, 294, 295, 296, 297, 298, 299, 300, 301, 302, 303, 304, 305, 306, 307, 308, 309, 310, 311, 312, 313, 314, 315, 316, 317, 318, 319, 320, 321, 322, 323, 324, 325, 326, 327, 328, 329, 330, 331, 332, 333, 334, 335, 336, 337, 338, 339, 340, 341, 342, 343, 344, 345, 346, 347, 348, 349, 350, 351, 352, 353, 354, 355, 356, 357, 358, 359, 360, 361, 362, 363, 364, 365, 366, 367, 368, 369, 370, 371, 372, 373, 374, 375, 376, 377, 378, 379, 380, 381, 382, 383, 384, 385, 386, 387, 388, 389, 390, 391, 392, 393, 394, 395, 396, 397, 398, 399, 400, 401, 402, 403, 404, 405, 406, 407, 408, 409, 410, 411, 412, 413, 414, 415, 416, 417, 418, 419, 420, 421, 422, 423, 424, 425, 426, 427, 428, 429, 430, 431, 432, 433, 434, 435, 436, 437, 438, 439, 440, 441, 442, 443, 444, 445, 446, 447, 448, 449, 450, 451, 452, 453, 454, 455, 456, 457, 458, 459, 460, 461, 462, 463, 464, 465, 466, 467, 468, 469, 470, 471, 472, 473, 474, 475, 476, 477, 478, 479, 480, 481, 482, 483, 484, 485, 486, 487, 488, 489, 490, 491, 492, 493, 494, 495, 496, 497, 498, 499, 500, 501, 502, 503, 504, 505, 506, 507, 508, 509, 510, 511, 512, 513, 514, 515, 516, 517, 518, 519, 520, 521, 522, 523, 524, 525, 526, 527, 528, 529, 530, 531, 532, 533, 534, 535, 536, 537, 538, 539, 540, 541, 542, 543, 544, 545, 546, 547, 548, 549, 550, 551, 552, 553, 554, 555, 556, 557, 558, 559, 560, 561, 562, 563, 564, 565, 566, 567, 568, 569, 570, 571, 572, 573, 574, 575, 576, 577, 578, 579, 580, 581, 582, 583, 584, 585, 586, 587, 588, 589, 590, 591, 592, 593, 594, 595, 596, 597, 598, 599, 600, 601, 602, 603, 604, 605, 606, 607, 608, 609, 610, 611, 612, 613, 614, 615, 616, 617, 618, 619, 620, 621, 622, 623, 624, 625, 626, 627, 628, 629, 630, 631, 632, 633, 634, 635, 636, 637, 638, 639, 640, 641, 642, 643, 644, 645, 646, 647, 648, 649, 650, 651, 652, 653, 654, 655, 656, 657, 658, 659, 660, 661, 662, 663, 664, 665, 666, 667, 668, 669, 670, 671, 672, 673, 674, 675, 676, 677, 678, 679, 680, 681, 682, 683, 684, 685, 686, 687, 688, 689, 690, 691, 692, 693, 694, 695, 696, 697, 698, 699, 700, 701, 702, 703, 704, 705, 706, 707, 708, 709, 710, 711, 712, 713, 714, 715, 716, 717, 718, 719, 720, 721, 722, 723, 724, 725, 726, 727, 728, 729, 730, 731, 732, 733, 734, 735, 736, 737, 738, 739, 740, 741, 742, 743, 744, 745, 746, 747, 748, 749, 750, 751, 752, 753, 754, 755, 756, 757, 758, 759, 760, 761, 762, 763, 764, 765, 766, 767, 768, 769, 770, 771, 772, 773, 774, 775, 776, 777, 778, 779, 780, 781, 782, 783, 784, 785, 786, 787, 788, 789, 790, 791, 792, 793, 794, 795, 796, 797, 798, 799, 800, 801, 802, 803, 804, 805, 806, 807, 808, 809, 810, 811, 812, 813, 814, 815, 816, 817, 818, 819, 820, 821, 822, 823, 824, 825, 826, 827, 828, 829, 830, 831, 832, 833, 834, 835, 836, 837, 838, 839, 840, 841, 842, 843, 844, 845, 846, 847, 848, 849, 850, 851, 852, 853, 854, 855, 856, 857, 858, 859, 860, 861, 862, 863, 864, 865, 866, 867, 868, 869, 870, 871, 872, 873, 874, 875, 876, 877, 878, 879, 880, 881, 882, 883, 884, 885, 886, 887, 888, 889, 890, 891, 892, 893, 894, 895, 896, 897, 898, 899, 900, 901, 902, 903, 904, 905, 906, 907, 908, 909, 910, 911, 912, 913, 914, 915, 916, 917, 918, 919, 920, 921, 922, 923, 924, 925, 926, 927, 928, 929, 930, 931, 932, 933, 934, 935, 936, 937, 938, 939, 940, 941, 942, 943, 944, 945, 946, 947, 948, 949, 950, 951, 952, 953, 954, 955, 956, 957, 958, 959, 960, 961, 962, 963, 964, 965, 966, 967, 968, 969, 970, 971, 972, 973, 974, 975, 976, 977, 978, 979, 980, 981, 982, 983, 984, 985, 986, 987, 988, 989, 990, 991, 992, 993, 994, 995, 996, 997, 998, 999, 1000

MAIN CONTRACTOR :
Gammon

STRUCTURAL ENGINEER :
ARUP

FACADE CONSULTANT:
MEINHARDT

NOTE :
 1. ALL DIMENSIONS ARE IN mm.
 2. ALL ELEVATIONS ARE VIEWED FROM OUTSIDE.
 3. ALL DIMENSIONS TO BE VERIFIED ON SITE BEFORE FABRICATION.

LEGEND :
 (X1) --- DETAIL MARK NO.
 (X001) --- REFER SHEET NO.
 1. F.F.L. --- FINISHED FLOOR LEVEL
 2. S.F.L. --- STRUCTURAL FLOOR LEVEL
 3. (R) --- REVERSED DETAIL
 4. ▲ --- FIXING LOCATION
 5. △ --- FIXING LUG LOCATION
 6. GLASS LEGEND
 GL01 --- 8mm+12mm AIR GAP+10mm THK. I.G.U.
 GL01a --- 8mm+9mm AIR GAP+12mm THK. I.G.U.
 GL03 --- 6mm+12mm AIR GAP+6mm THK. I.G.U.
 GL04 --- 10mm THK. TEMPERED GLASS (PROTECTIVE BARRIER)
 GL05 --- 6mm+12mm AIR GAP+8mm THK. I.G.U.

NO.	DATE	REVISION	BY
A	06/01/2021	REVISION SUBJECT TO ARCH.COMMENT	lvart

JOB NO. : J-852
 PROJECT : PROPOSED RESIDENTIAL DEVELOPMENT AT 139 - 147 ARGYLE STREET, NKIL 6005, 6035 R.P., 6036 R.P., 6037 R.P. & 6038 R.P.

TITLE : SCHEDULE FOR Plenum Box AT TOWER 1 (1-21F)

DATE : 05-Dec-19 SCALE : 1:40

DRAWN BY : MN CHECKED BY : DW

美特鋁質有限公司
MIDI ALUMINIUM FABRICATOR LTD.
 Units 6-8, Sunray Industrial Centre, 1/F
 610 Cha Kwo Ling Road, Kowloon
 Tel:23489211-4 Fax:(852)27727666

DWG NO. : J852-SD-PB-4106 REV. : A

ELEVATION

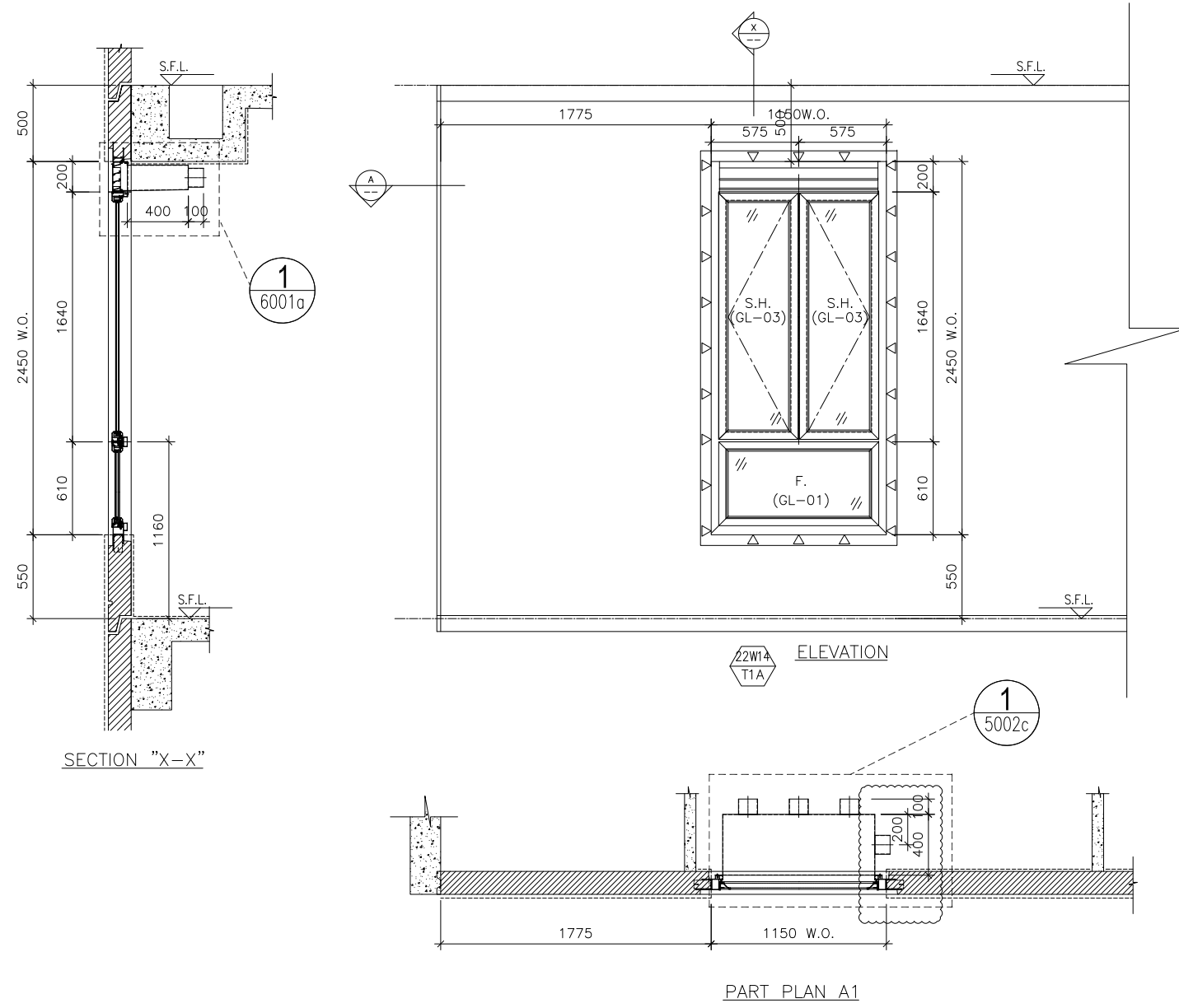

WINDOW MARK	22W14 T1A
LOCATION	22/F M. BATH AT TOWER 1 FLAT A
SECTION	70mm ALUM. SECTION
GLAZING	GL-01, GL-03
QUANTITY	1
REMARKS	FACADE (PF-22)

B.D. REF :

CLIENT :

ARCHITECT :
AGC DESIGN LTD
 101, 102, 103, 104, 105, 106, 107, 108, 109, 110, 111, 112, 113, 114, 115, 116, 117, 118, 119, 120, 121, 122, 123, 124, 125, 126, 127, 128, 129, 130, 131, 132, 133, 134, 135, 136, 137, 138, 139, 140, 141, 142, 143, 144, 145, 146, 147, 148, 149, 150, 151, 152, 153, 154, 155, 156, 157, 158, 159, 160, 161, 162, 163, 164, 165, 166, 167, 168, 169, 170, 171, 172, 173, 174, 175, 176, 177, 178, 179, 180, 181, 182, 183, 184, 185, 186, 187, 188, 189, 190, 191, 192, 193, 194, 195, 196, 197, 198, 199, 200, 201, 202, 203, 204, 205, 206, 207, 208, 209, 210, 211, 212, 213, 214, 215, 216, 217, 218, 219, 220, 221, 222, 223, 224, 225, 226, 227, 228, 229, 230, 231, 232, 233, 234, 235, 236, 237, 238, 239, 240, 241, 242, 243, 244, 245, 246, 247, 248, 249, 250, 251, 252, 253, 254, 255, 256, 257, 258, 259, 260, 261, 262, 263, 264, 265, 266, 267, 268, 269, 270, 271, 272, 273, 274, 275, 276, 277, 278, 279, 280, 281, 282, 283, 284, 285, 286, 287, 288, 289, 290, 291, 292, 293, 294, 295, 296, 297, 298, 299, 300, 301, 302, 303, 304, 305, 306, 307, 308, 309, 310, 311, 312, 313, 314, 315, 316, 317, 318, 319, 320, 321, 322, 323, 324, 325, 326, 327, 328, 329, 330, 331, 332, 333, 334, 335, 336, 337, 338, 339, 340, 341, 342, 343, 344, 345, 346, 347, 348, 349, 350, 351, 352, 353, 354, 355, 356, 357, 358, 359, 360, 361, 362, 363, 364, 365, 366, 367, 368, 369, 370, 371, 372, 373, 374, 375, 376, 377, 378, 379, 380, 381, 382, 383, 384, 385, 386, 387, 388, 389, 390, 391, 392, 393, 394, 395, 396, 397, 398, 399, 400, 401, 402, 403, 404, 405, 406, 407, 408, 409, 410, 411, 412, 413, 414, 415, 416, 417, 418, 419, 420, 421, 422, 423, 424, 425, 426, 427, 428, 429, 430, 431, 432, 433, 434, 435, 436, 437, 438, 439, 440, 441, 442, 443, 444, 445, 446, 447, 448, 449, 450, 451, 452, 453, 454, 455, 456, 457, 458, 459, 460, 461, 462, 463, 464, 465, 466, 467, 468, 469, 470, 471, 472, 473, 474, 475, 476, 477, 478, 479, 480, 481, 482, 483, 484, 485, 486, 487, 488, 489, 490, 491, 492, 493, 494, 495, 496, 497, 498, 499, 500, 501, 502, 503, 504, 505, 506, 507, 508, 509, 510, 511, 512, 513, 514, 515, 516, 517, 518, 519, 520, 521, 522, 523, 524, 525, 526, 527, 528, 529, 530, 531, 532, 533, 534, 535, 536, 537, 538, 539, 540, 541, 542, 543, 544, 545, 546, 547, 548, 549, 550, 551, 552, 553, 554, 555, 556, 557, 558, 559, 560, 561, 562, 563, 564, 565, 566, 567, 568, 569, 570, 571, 572, 573, 574, 575, 576, 577, 578, 579, 580, 581, 582, 583, 584, 585, 586, 587, 588, 589, 590, 591, 592, 593, 594, 595, 596, 597, 598, 599, 600, 601, 602, 603, 604, 605, 606, 607, 608, 609, 610, 611, 612, 613, 614, 615, 616, 617, 618, 619, 620, 621, 622, 623, 624, 625, 626, 627, 628, 629, 630, 631, 632, 633, 634, 635, 636, 637, 638, 639, 640, 641, 642, 643, 644, 645, 646, 647, 648, 649, 650, 651, 652, 653, 654, 655, 656, 657, 658, 659, 660, 661, 662, 663, 664, 665, 666, 667, 668, 669, 670, 671, 672, 673, 674, 675, 676, 677, 678, 679, 680, 681, 682, 683, 684, 685, 686, 687, 688, 689, 690, 691, 692, 693, 694, 695, 696, 697, 698, 699, 700, 701, 702, 703, 704, 705, 706, 707, 708, 709, 710, 711, 712, 713, 714, 715, 716, 717, 718, 719, 720, 721, 722, 723, 724, 725, 726, 727, 728, 729, 730, 731, 732, 733, 734, 735, 736, 737, 738, 739, 740, 741, 742, 743, 744, 745, 746, 747, 748, 749, 750, 751, 752, 753, 754, 755, 756, 757, 758, 759, 760, 761, 762, 763, 764, 765, 766, 767, 768, 769, 770, 771, 772, 773, 774, 775, 776, 777, 778, 779, 780, 781, 782, 783, 784, 785, 786, 787, 788, 789, 790, 791, 792, 793, 794, 795, 796, 797, 798, 799, 800, 801, 802, 803, 804, 805, 806, 807, 808, 809, 810, 811, 812, 813, 814, 815, 816, 817, 818, 819, 820, 821, 822, 823, 824, 825, 826, 827, 828, 829, 830, 831, 832, 833, 834, 835, 836, 837, 838, 839, 840, 841, 842, 843, 844, 845, 846, 847, 848, 849, 850, 851, 852, 853, 854, 855, 856, 857, 858, 859, 860, 861, 862, 863, 864, 865, 866, 867, 868, 869, 870, 871, 872, 873, 874, 875, 876, 877, 878, 879, 880, 881, 882, 883, 884, 885, 886, 887, 888, 889, 890, 891, 892, 893, 894, 895, 896, 897, 898, 899, 900, 901, 902, 903, 904, 905, 906, 907, 908, 909, 910, 911, 912, 913, 914, 915, 916, 917, 918, 919, 920, 921, 922, 923, 924, 925, 926, 927, 928, 929, 930, 931, 932, 933, 934, 935, 936, 937, 938, 939, 940, 941, 942, 943, 944, 945, 946, 947, 948, 949, 950, 951, 952, 953, 954, 955, 956, 957, 958, 959, 960, 961, 962, 963, 964, 965, 966, 967, 968, 969, 970, 971, 972, 973, 974, 975, 976, 977, 978, 979, 980, 981, 982, 983, 984, 985, 986, 987, 988, 989, 990, 991, 992, 993, 994, 995, 996, 997, 998, 999, 1000

NOTE :

- ALL DIMENSIONS ARE IN mm.
- ALL ELEVATIONS ARE VIEWED FROM OUTSIDE.
- ALL DIMENSIONS TO BE VERIFIED ON SITE BEFORE FABRICATION.

LEGEND :

x1 — DETAIL MARK NO.
 x001 — REFER SHEET NO.

- F.F.L. — FINISHED FLOOR LEVEL
- S.F.L. — STRUCTURAL FLOOR LEVEL
- ⊖ — REVERSED DETAIL
- ▲ — FIXING LOCATION
- △ — FIXING LUG LOCATION

GLASS LEGEND

GL01 — 8mm+12mm AIR GAP+10mm THK. I.G.U.
 GL01a — 8mm+9mm AIR GAP+12mm THK. I.G.U.
 GL03 — 6mm+12mm AIR GAP+6mm THK. I.G.U.
 GL04 — 10mm THK. TEMPERED GLASS (PROTECTIVE BARRIER)
 GL05 — 6mm+12mm AIR GAP+8mm THK. I.G.U.

B	06/01/2021	REVISION SUBJECT TO ARCH.COMMENT	Ivan
A	09/12/2020	REVISION SUBJECT TO ARCH.COMMENT	Ivan
NO.	DATE	REVISED	BY

JOB NO. : J-852

PROJECT :
 PROPOSED RESIDENTIAL DEVELOPMENT
 AT 139 - 147 ARGYLE STREET,
 NKIL 6005, 6035 R.P., 6036 R.P.,
 6037 R.P. & 6038 R.P.

TITLE :
 SCHEDULE FOR Plenum Box
 AT TOWER 1 (22F)

DATE : 05-Dec-19 SCALE : 1:40

DRAWN BY : MN CHECKED BY : DW

美特鋁質有限公司
MIDI ALUMINIUM FABRICATOR LTD.
 Units 6-8, Sunray Industrial Centre, 1/F
 610 Cha Kwo Ling Road, Kowloon
 Tel:23489211-4 Fax:(852)2727666

DWG NO. : J852-SD-PB-4107 REV. : B

ELEVATION

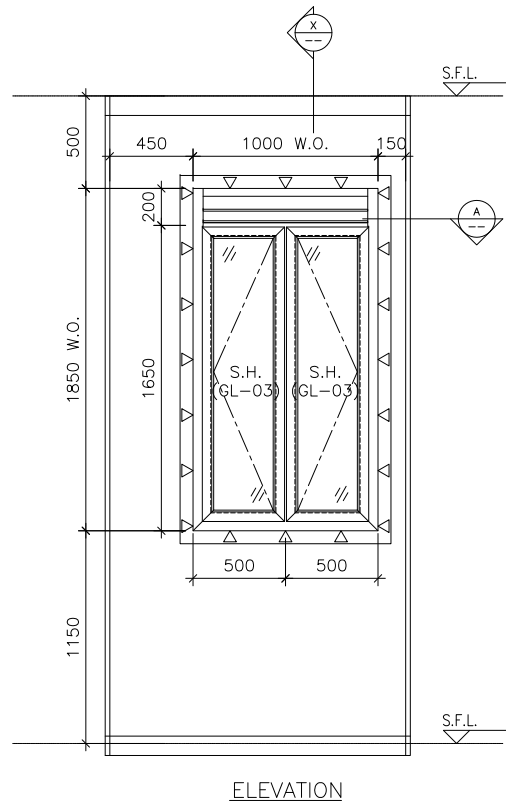

ELEVATION

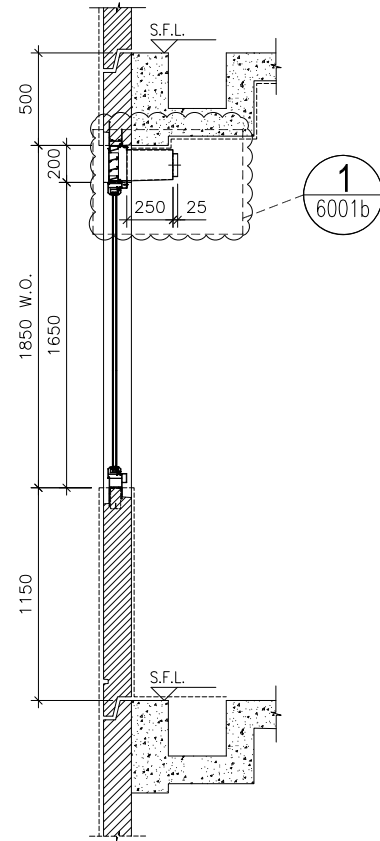

SECTION "X-X"

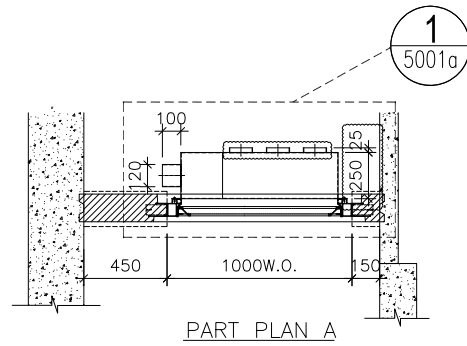

PART PLAN A

WINDOW MARK



LOCATION 22/F KIT. AT TOWER 1 FLAT C

SECTION 70mm ALUM. SECTION

GLAZING GL-03

QUANTITY 1

REMARKS FACADE (PF-31)

B.D. REF :

CLIENT :

ARCHITECT :

AGC
DESIGN LTD

MAIN CONTRACTOR :

Gammon

STRUCTURAL ENGINEER :

ARUP

FACADE CONSULTANT:

MEINHARDT

NOTE :

1. ALL DIMENSIONS ARE IN mm.
2. ALL ELEVATIONS ARE VIEWED FROM OUTSIDE.
3. ALL DIMENSIONS TO BE VERIFIED ON SITE BEFORE FABRICATION.

LEGEND :

- (x1) --- DETAIL MARK NO.
- (x001) --- REFER SHEET NO.

1. F.F.L. --- FINISHED FLOOR LEVEL
2. S.F.L. --- STRUCTURAL FLOOR LEVEL
3. (R) --- REVERSED DETAIL
4. ▲ --- FIXING LOCATION
5. △ --- FIXING LUG LOCATION

6. GLASS LEGEND

- GL01 --- 8mm+12mm AIR GAP+10mm THK. I.G.U.
- GL01a --- 8mm+9mm AIR GAP+12mm THK. I.G.U.
- GL03 --- 6mm+12mm AIR GAP+6mm THK. I.G.U.
- GL04 --- 10mm THK. TEMPERED GLASS (PROTECTIVE BARRIER)
- GL05 --- 6mm+12mm AIR GAP+8mm THK. I.G.U.

B	05/03/2021	REVISION SUBJECT TO ARCH.COMMENT	Ivan
A	09/12/2020	REVISION SUBJECT TO ARCH.COMMENT	Ivan
NO.	DATE	REVISION	BY

JOB NO. : J-852

PROJECT :
PROPOSED RESIDENTIAL DEVELOPMENT
AT 139 - 147 ARGYLE STREET,
NKIL 6005, 6035 R.P., 6036 R.P.,
6037 R.P. & 6038 R.P.

TITLE :
SCHEDULE FOR Plenum Box
AT TOWER 1 (22F)

DATE : 05-Dec-19 SCALE : 1:40

DRAWN BY : MN CHECKED BY : DW

美特鋁質有限公司
MIDI ALUMINIUM FABRICATOR LTD.
Units 6-8, Sunray Industrial Centre, 1/F
610 Cha Kwo Ling Road, Kowloon
Tel:23489211-4 Fax:(852)2727666

DWG NO. : J852-SD-PB-4108 REV. : B

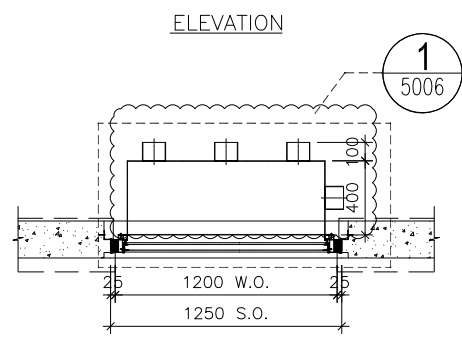
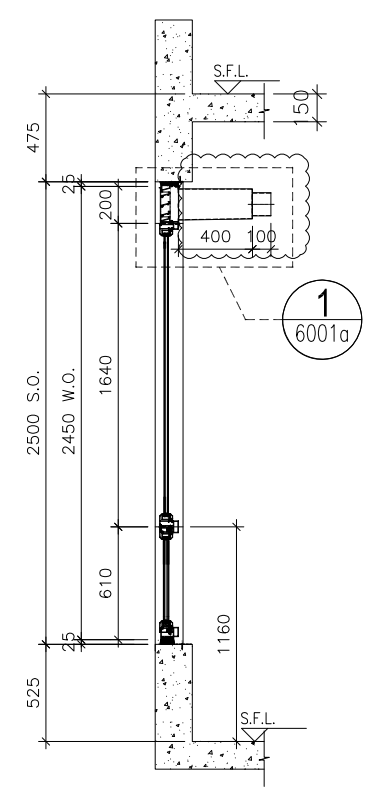
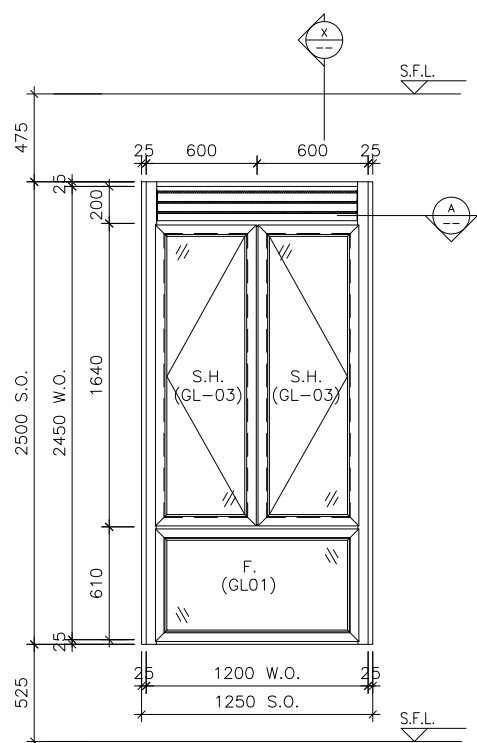

ELEVATION

SECTION "X-X"

PART PLAN A

ELEVATION

WINDOW MARK	
LOCATION	22/F BATH AT TOWER 1 FLAT A
SECTION	70mm ALUM. SECTION
GLAZING	GL-01, GL-03
QUANTITY	1
REMARKS	

B.D. REF :

CLIENT :

ARCHITECT :

 AGC DESIGN LTD
 181, 182, 183, 184, 185, 186, 187, 188, 189, 190, 191, 192, 193, 194, 195, 196, 197, 198, 199, 200, 201, 202, 203, 204, 205, 206, 207, 208, 209, 210, 211, 212, 213, 214, 215, 216, 217, 218, 219, 220, 221, 222, 223, 224, 225, 226, 227, 228, 229, 230, 231, 232, 233, 234, 235, 236, 237, 238, 239, 240, 241, 242, 243, 244, 245, 246, 247, 248, 249, 250, 251, 252, 253, 254, 255, 256, 257, 258, 259, 260, 261, 262, 263, 264, 265, 266, 267, 268, 269, 270, 271, 272, 273, 274, 275, 276, 277, 278, 279, 280, 281, 282, 283, 284, 285, 286, 287, 288, 289, 290, 291, 292, 293, 294, 295, 296, 297, 298, 299, 300, 301, 302, 303, 304, 305, 306, 307, 308, 309, 310, 311, 312, 313, 314, 315, 316, 317, 318, 319, 320, 321, 322, 323, 324, 325, 326, 327, 328, 329, 330, 331, 332, 333, 334, 335, 336, 337, 338, 339, 340, 341, 342, 343, 344, 345, 346, 347, 348, 349, 350, 351, 352, 353, 354, 355, 356, 357, 358, 359, 360, 361, 362, 363, 364, 365, 366, 367, 368, 369, 370, 371, 372, 373, 374, 375, 376, 377, 378, 379, 380, 381, 382, 383, 384, 385, 386, 387, 388, 389, 390, 391, 392, 393, 394, 395, 396, 397, 398, 399, 400, 401, 402, 403, 404, 405, 406, 407, 408, 409, 410, 411, 412, 413, 414, 415, 416, 417, 418, 419, 420, 421, 422, 423, 424, 425, 426, 427, 428, 429, 430, 431, 432, 433, 434, 435, 436, 437, 438, 439, 440, 441, 442, 443, 444, 445, 446, 447, 448, 449, 450, 451, 452, 453, 454, 455, 456, 457, 458, 459, 460, 461, 462, 463, 464, 465, 466, 467, 468, 469, 470, 471, 472, 473, 474, 475, 476, 477, 478, 479, 480, 481, 482, 483, 484, 485, 486, 487, 488, 489, 490, 491, 492, 493, 494, 495, 496, 497, 498, 499, 500, 501, 502, 503, 504, 505, 506, 507, 508, 509, 510, 511, 512, 513, 514, 515, 516, 517, 518, 519, 520, 521, 522, 523, 524, 525, 526, 527, 528, 529, 530, 531, 532, 533, 534, 535, 536, 537, 538, 539, 540, 541, 542, 543, 544, 545, 546, 547, 548, 549, 550, 551, 552, 553, 554, 555, 556, 557, 558, 559, 560, 561, 562, 563, 564, 565, 566, 567, 568, 569, 570, 571, 572, 573, 574, 575, 576, 577, 578, 579, 580, 581, 582, 583, 584, 585, 586, 587, 588, 589, 590, 591, 592, 593, 594, 595, 596, 597, 598, 599, 600, 601, 602, 603, 604, 605, 606, 607, 608, 609, 610, 611, 612, 613, 614, 615, 616, 617, 618, 619, 620, 621, 622, 623, 624, 625, 626, 627, 628, 629, 630, 631, 632, 633, 634, 635, 636, 637, 638, 639, 640, 641, 642, 643, 644, 645, 646, 647, 648, 649, 650, 651, 652, 653, 654, 655, 656, 657, 658, 659, 660, 661, 662, 663, 664, 665, 666, 667, 668, 669, 670, 671, 672, 673, 674, 675, 676, 677, 678, 679, 680, 681, 682, 683, 684, 685, 686, 687, 688, 689, 690, 691, 692, 693, 694, 695, 696, 697, 698, 699, 700, 701, 702, 703, 704, 705, 706, 707, 708, 709, 710, 711, 712, 713, 714, 715, 716, 717, 718, 719, 720, 721, 722, 723, 724, 725, 726, 727, 728, 729, 730, 731, 732, 733, 734, 735, 736, 737, 738, 739, 740, 741, 742, 743, 744, 745, 746, 747, 748, 749, 750, 751, 752, 753, 754, 755, 756, 757, 758, 759, 760, 761, 762, 763, 764, 765, 766, 767, 768, 769, 770, 771, 772, 773, 774, 775, 776, 777, 778, 779, 780, 781, 782, 783, 784, 785, 786, 787, 788, 789, 790, 791, 792, 793, 794, 795, 796, 797, 798, 799, 800, 801, 802, 803, 804, 805, 806, 807, 808, 809, 810, 811, 812, 813, 814, 815, 816, 817, 818, 819, 820, 821, 822, 823, 824, 825, 826, 827, 828, 829, 830, 831, 832, 833, 834, 835, 836, 837, 838, 839, 840, 841, 842, 843, 844, 845, 846, 847, 848, 849, 850, 851, 852, 853, 854, 855, 856, 857, 858, 859, 860, 861, 862, 863, 864, 865, 866, 867, 868, 869, 870, 871, 872, 873, 874, 875, 876, 877, 878, 879, 880, 881, 882, 883, 884, 885, 886, 887, 888, 889, 890, 891, 892, 893, 894, 895, 896, 897, 898, 899, 900, 901, 902, 903, 904, 905, 906, 907, 908, 909, 910, 911, 912, 913, 914, 915, 916, 917, 918, 919, 920, 921, 922, 923, 924, 925, 926, 927, 928, 929, 930, 931, 932, 933, 934, 935, 936, 937, 938, 939, 940, 941, 942, 943, 944, 945, 946, 947, 948, 949, 950, 951, 952, 953, 954, 955, 956, 957, 958, 959, 960, 961, 962, 963, 964, 965, 966, 967, 968, 969, 970, 971, 972, 973, 974, 975, 976, 977, 978, 979, 980, 981, 982, 983, 984, 985, 986, 987, 988, 989, 990, 991, 992, 993, 994, 995, 996, 997, 998, 999, 1000

NOTE :

1. ALL DIMENSIONS ARE IN mm.
2. ALL ELEVATIONS ARE VIEWED FROM OUTSIDE.
3. ALL DIMENSIONS TO BE VERIFIED ON SITE BEFORE FABRICATION.

LEGEND :

(X1) --- DETAIL MARK NO.
 (X001) --- REFER SHEET NO.

1. F.F.L. --- FINISHED FLOOR LEVEL
2. S.F.L. --- STRUCTURAL FLOOR LEVEL
3. (R) --- REVERSED DETAIL

NO.	DATE	REVISION	BY
A	07/11/2020	REVISION SUBJECT TO ARCH.COMMENT	Ivan

JOB NO. : J-852

PROJECT :
 PROPOSED RESIDENTIAL DEVELOPMENT
 AT 139 - 147 ARGYLE STREET,
 NKIL 6005, 6035 R.P., 6036 R.P.,
 6037 R.P. & 6038 R.P.

TITLE :
 SCHEDULE FOR Plenum Box
 AT TOWER 1 (22F)

DATE : 05-FEB-20 SCALE : 1:100

DRAWN BY : MN CHECKED BY : DW

MIDI ALUMINIUM FABRICATOR LTD.
 Units 6-8, Sunray Industrial Centre, 1/F
 610 Cha Kwo Ling Road, Kowloon
 Tel:23489211-4 Fax:(852)2727666

DWG NO. : J852-SD-PB-4109 REV. : A

ELEVATION

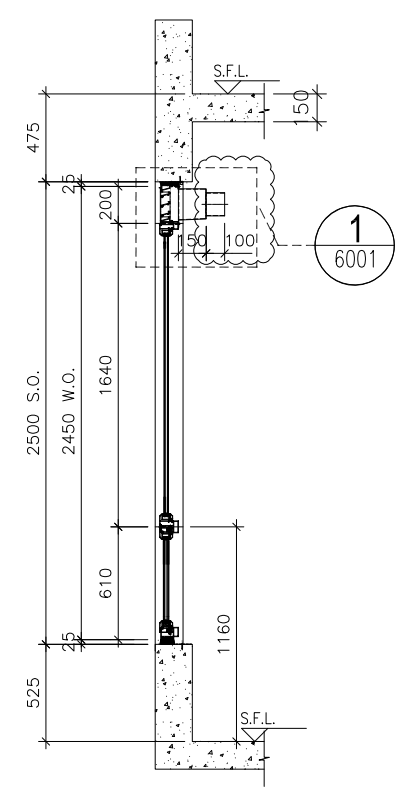
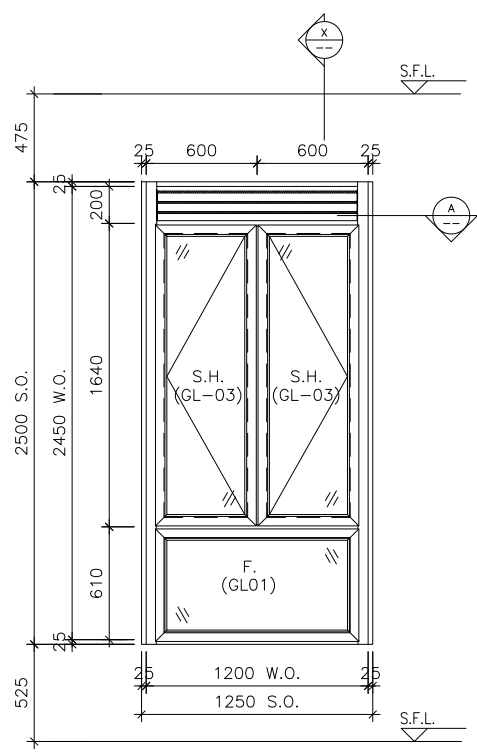

SECTION "X-X"

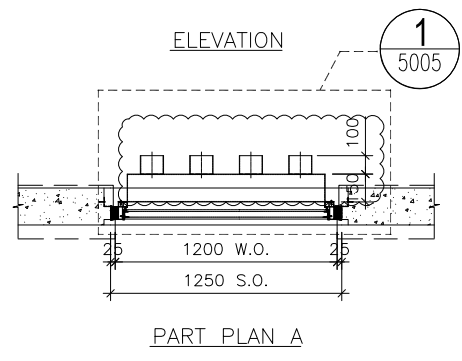

PART PLAN A

WINDOW MARK	
LOCATION	22/F EN. B 3 AT TOWER 1 FLAT A
SECTION	70mm ALUM. SECTION
GLAZING	GL-01, GL-03
QUANTITY	1
REMARKS	

B.D. REF :

CLIENT :

ARCHITECT :
AGC DESIGN LTD
 101, 102, 103, 104, 105, 106, 107, 108, 109, 110, 111, 112, 113, 114, 115, 116, 117, 118, 119, 120, 121, 122, 123, 124, 125, 126, 127, 128, 129, 130, 131, 132, 133, 134, 135, 136, 137, 138, 139, 140, 141, 142, 143, 144, 145, 146, 147, 148, 149, 150, 151, 152, 153, 154, 155, 156, 157, 158, 159, 160, 161, 162, 163, 164, 165, 166, 167, 168, 169, 170, 171, 172, 173, 174, 175, 176, 177, 178, 179, 180, 181, 182, 183, 184, 185, 186, 187, 188, 189, 190, 191, 192, 193, 194, 195, 196, 197, 198, 199, 200, 201, 202, 203, 204, 205, 206, 207, 208, 209, 210, 211, 212, 213, 214, 215, 216, 217, 218, 219, 220, 221, 222, 223, 224, 225, 226, 227, 228, 229, 230, 231, 232, 233, 234, 235, 236, 237, 238, 239, 240, 241, 242, 243, 244, 245, 246, 247, 248, 249, 250, 251, 252, 253, 254, 255, 256, 257, 258, 259, 260, 261, 262, 263, 264, 265, 266, 267, 268, 269, 270, 271, 272, 273, 274, 275, 276, 277, 278, 279, 280, 281, 282, 283, 284, 285, 286, 287, 288, 289, 290, 291, 292, 293, 294, 295, 296, 297, 298, 299, 300, 301, 302, 303, 304, 305, 306, 307, 308, 309, 310, 311, 312, 313, 314, 315, 316, 317, 318, 319, 320, 321, 322, 323, 324, 325, 326, 327, 328, 329, 330, 331, 332, 333, 334, 335, 336, 337, 338, 339, 340, 341, 342, 343, 344, 345, 346, 347, 348, 349, 350, 351, 352, 353, 354, 355, 356, 357, 358, 359, 360, 361, 362, 363, 364, 365, 366, 367, 368, 369, 370, 371, 372, 373, 374, 375, 376, 377, 378, 379, 380, 381, 382, 383, 384, 385, 386, 387, 388, 389, 390, 391, 392, 393, 394, 395, 396, 397, 398, 399, 400, 401, 402, 403, 404, 405, 406, 407, 408, 409, 410, 411, 412, 413, 414, 415, 416, 417, 418, 419, 420, 421, 422, 423, 424, 425, 426, 427, 428, 429, 430, 431, 432, 433, 434, 435, 436, 437, 438, 439, 440, 441, 442, 443, 444, 445, 446, 447, 448, 449, 450, 451, 452, 453, 454, 455, 456, 457, 458, 459, 460, 461, 462, 463, 464, 465, 466, 467, 468, 469, 470, 471, 472, 473, 474, 475, 476, 477, 478, 479, 480, 481, 482, 483, 484, 485, 486, 487, 488, 489, 490, 491, 492, 493, 494, 495, 496, 497, 498, 499, 500, 501, 502, 503, 504, 505, 506, 507, 508, 509, 510, 511, 512, 513, 514, 515, 516, 517, 518, 519, 520, 521, 522, 523, 524, 525, 526, 527, 528, 529, 530, 531, 532, 533, 534, 535, 536, 537, 538, 539, 540, 541, 542, 543, 544, 545, 546, 547, 548, 549, 550, 551, 552, 553, 554, 555, 556, 557, 558, 559, 560, 561, 562, 563, 564, 565, 566, 567, 568, 569, 570, 571, 572, 573, 574, 575, 576, 577, 578, 579, 580, 581, 582, 583, 584, 585, 586, 587, 588, 589, 590, 591, 592, 593, 594, 595, 596, 597, 598, 599, 600, 601, 602, 603, 604, 605, 606, 607, 608, 609, 610, 611, 612, 613, 614, 615, 616, 617, 618, 619, 620, 621, 622, 623, 624, 625, 626, 627, 628, 629, 630, 631, 632, 633, 634, 635, 636, 637, 638, 639, 640, 641, 642, 643, 644, 645, 646, 647, 648, 649, 650, 651, 652, 653, 654, 655, 656, 657, 658, 659, 660, 661, 662, 663, 664, 665, 666, 667, 668, 669, 670, 671, 672, 673, 674, 675, 676, 677, 678, 679, 680, 681, 682, 683, 684, 685, 686, 687, 688, 689, 690, 691, 692, 693, 694, 695, 696, 697, 698, 699, 700, 701, 702, 703, 704, 705, 706, 707, 708, 709, 710, 711, 712, 713, 714, 715, 716, 717, 718, 719, 720, 721, 722, 723, 724, 725, 726, 727, 728, 729, 730, 731, 732, 733, 734, 735, 736, 737, 738, 739, 740, 741, 742, 743, 744, 745, 746, 747, 748, 749, 750, 751, 752, 753, 754, 755, 756, 757, 758, 759, 760, 761, 762, 763, 764, 765, 766, 767, 768, 769, 770, 771, 772, 773, 774, 775, 776, 777, 778, 779, 780, 781, 782, 783, 784, 785, 786, 787, 788, 789, 790, 791, 792, 793, 794, 795, 796, 797, 798, 799, 800, 801, 802, 803, 804, 805, 806, 807, 808, 809, 810, 811, 812, 813, 814, 815, 816, 817, 818, 819, 820, 821, 822, 823, 824, 825, 826, 827, 828, 829, 830, 831, 832, 833, 834, 835, 836, 837, 838, 839, 840, 841, 842, 843, 844, 845, 846, 847, 848, 849, 850, 851, 852, 853, 854, 855, 856, 857, 858, 859, 860, 861, 862, 863, 864, 865, 866, 867, 868, 869, 870, 871, 872, 873, 874, 875, 876, 877, 878, 879, 880, 881, 882, 883, 884, 885, 886, 887, 888, 889, 890, 891, 892, 893, 894, 895, 896, 897, 898, 899, 900, 901, 902, 903, 904, 905, 906, 907, 908, 909, 910, 911, 912, 913, 914, 915, 916, 917, 918, 919, 920, 921, 922, 923, 924, 925, 926, 927, 928, 929, 930, 931, 932, 933, 934, 935, 936, 937, 938, 939, 940, 941, 942, 943, 944, 945, 946, 947, 948, 949, 950, 951, 952, 953, 954, 955, 956, 957, 958, 959, 960, 961, 962, 963, 964, 965, 966, 967, 968, 969, 970, 971, 972, 973, 974, 975, 976, 977, 978, 979, 980, 981, 982, 983, 984, 985, 986, 987, 988, 989, 990, 991, 992, 993, 994, 995, 996, 997, 998, 999, 1000

MAIN CONTRACTOR :
Gammon

STRUCTURAL ENGINEER :
ARUP

FACADE CONSULTANT:
MEINHARDT

NOTE :
 1. ALL DIMENSIONS ARE IN mm.
 2. ALL ELEVATIONS ARE VIEWED FROM OUTSIDE.
 3. ALL DIMENSIONS TO BE VERIFIED ON SITE BEFORE FABRICATION.

LEGEND :
 (X1) --- DETAIL MARK NO.
 (X001) --- REFER SHEET NO.

1. F.F.L. --- FINISHED FLOOR LEVEL
 2. S.F.L. --- STRUCTURAL FLOOR LEVEL
 3. (R) --- REVERSED DETAIL

A	07/11/2020	REVISION SUBJECT TO ARCH.COMMENT	Ivan
NO.	DATE	REVISION	BY

JOB NO. : J-852

PROJECT :
 PROPOSED RESIDENTIAL DEVELOPMENT
 AT 139 - 147 ARGYLE STREET,
 NKIL 6005, 6035 R.P., 6036 R.P.,
 6037 R.P. & 6038 R.P.

TITLE :
 SCHEDULE FOR Plenum Box
 AT TOWER 1 (22F)

DATE : 05-FEB-20 SCALE : 1:100

DRAWN BY : MN CHECKED BY : DW

美特鋁質有限公司
MIDI ALUMINIUM FABRICATOR LTD.
 Units 6-8, Sunray Industrial Centre, 1/F
 610 Cha Kwo Ling Road, Kowloon
 Tel:23489211-4 Fax:(852)2727666

DWG NO. : J852-SD-PB-4110 REV. : A

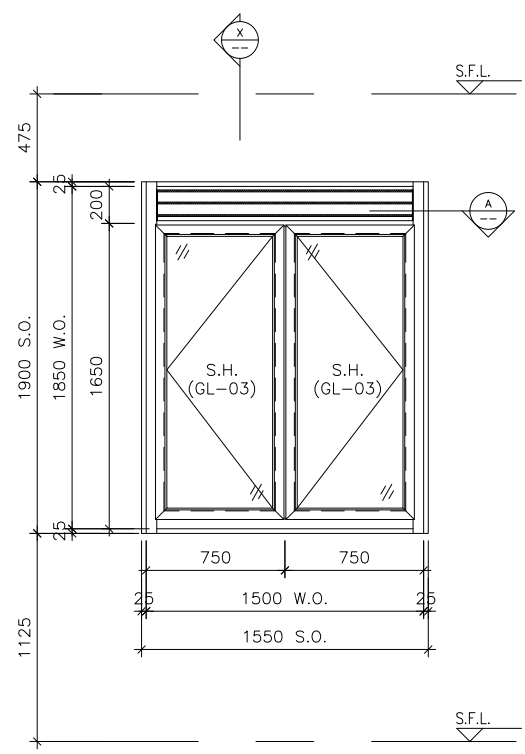

ELEVATION

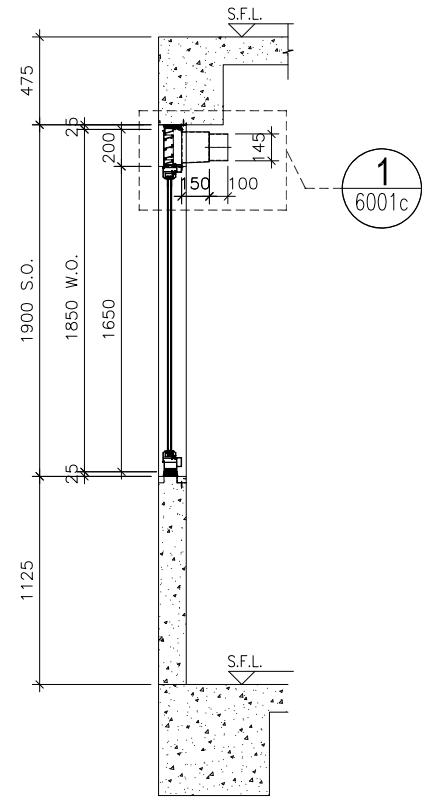

SECTION "X-X"

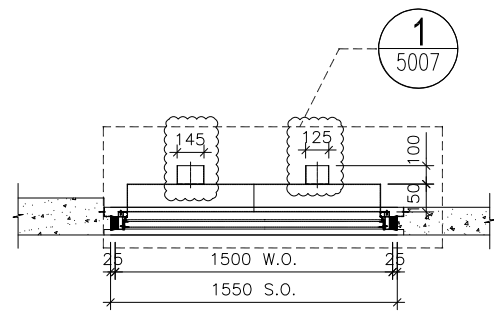

PART PLAN A

ELEVATION

B.D. REF :

CLIENT :

ARCHITECT :
AGC DESIGN LTD
 101, 102, 103, 104, 105, 106, 107, 108, 109, 110, 111, 112, 113, 114, 115, 116, 117, 118, 119, 120, 121, 122, 123, 124, 125, 126, 127, 128, 129, 130, 131, 132, 133, 134, 135, 136, 137, 138, 139, 140, 141, 142, 143, 144, 145, 146, 147, 148, 149, 150, 151, 152, 153, 154, 155, 156, 157, 158, 159, 160, 161, 162, 163, 164, 165, 166, 167, 168, 169, 170, 171, 172, 173, 174, 175, 176, 177, 178, 179, 180, 181, 182, 183, 184, 185, 186, 187, 188, 189, 190, 191, 192, 193, 194, 195, 196, 197, 198, 199, 200, 201, 202, 203, 204, 205, 206, 207, 208, 209, 210, 211, 212, 213, 214, 215, 216, 217, 218, 219, 220, 221, 222, 223, 224, 225, 226, 227, 228, 229, 230, 231, 232, 233, 234, 235, 236, 237, 238, 239, 240, 241, 242, 243, 244, 245, 246, 247, 248, 249, 250, 251, 252, 253, 254, 255, 256, 257, 258, 259, 260, 261, 262, 263, 264, 265, 266, 267, 268, 269, 270, 271, 272, 273, 274, 275, 276, 277, 278, 279, 280, 281, 282, 283, 284, 285, 286, 287, 288, 289, 290, 291, 292, 293, 294, 295, 296, 297, 298, 299, 300, 301, 302, 303, 304, 305, 306, 307, 308, 309, 310, 311, 312, 313, 314, 315, 316, 317, 318, 319, 320, 321, 322, 323, 324, 325, 326, 327, 328, 329, 330, 331, 332, 333, 334, 335, 336, 337, 338, 339, 340, 341, 342, 343, 344, 345, 346, 347, 348, 349, 350, 351, 352, 353, 354, 355, 356, 357, 358, 359, 360, 361, 362, 363, 364, 365, 366, 367, 368, 369, 370, 371, 372, 373, 374, 375, 376, 377, 378, 379, 380, 381, 382, 383, 384, 385, 386, 387, 388, 389, 390, 391, 392, 393, 394, 395, 396, 397, 398, 399, 400, 401, 402, 403, 404, 405, 406, 407, 408, 409, 410, 411, 412, 413, 414, 415, 416, 417, 418, 419, 420, 421, 422, 423, 424, 425, 426, 427, 428, 429, 430, 431, 432, 433, 434, 435, 436, 437, 438, 439, 440, 441, 442, 443, 444, 445, 446, 447, 448, 449, 450, 451, 452, 453, 454, 455, 456, 457, 458, 459, 460, 461, 462, 463, 464, 465, 466, 467, 468, 469, 470, 471, 472, 473, 474, 475, 476, 477, 478, 479, 480, 481, 482, 483, 484, 485, 486, 487, 488, 489, 490, 491, 492, 493, 494, 495, 496, 497, 498, 499, 500, 501, 502, 503, 504, 505, 506, 507, 508, 509, 510, 511, 512, 513, 514, 515, 516, 517, 518, 519, 520, 521, 522, 523, 524, 525, 526, 527, 528, 529, 530, 531, 532, 533, 534, 535, 536, 537, 538, 539, 540, 541, 542, 543, 544, 545, 546, 547, 548, 549, 550, 551, 552, 553, 554, 555, 556, 557, 558, 559, 560, 561, 562, 563, 564, 565, 566, 567, 568, 569, 570, 571, 572, 573, 574, 575, 576, 577, 578, 579, 580, 581, 582, 583, 584, 585, 586, 587, 588, 589, 590, 591, 592, 593, 594, 595, 596, 597, 598, 599, 600, 601, 602, 603, 604, 605, 606, 607, 608, 609, 610, 611, 612, 613, 614, 615, 616, 617, 618, 619, 620, 621, 622, 623, 624, 625, 626, 627, 628, 629, 630, 631, 632, 633, 634, 635, 636, 637, 638, 639, 640, 641, 642, 643, 644, 645, 646, 647, 648, 649, 650, 651, 652, 653, 654, 655, 656, 657, 658, 659, 660, 661, 662, 663, 664, 665, 666, 667, 668, 669, 670, 671, 672, 673, 674, 675, 676, 677, 678, 679, 680, 681, 682, 683, 684, 685, 686, 687, 688, 689, 690, 691, 692, 693, 694, 695, 696, 697, 698, 699, 700, 701, 702, 703, 704, 705, 706, 707, 708, 709, 710, 711, 712, 713, 714, 715, 716, 717, 718, 719, 720, 721, 722, 723, 724, 725, 726, 727, 728, 729, 730, 731, 732, 733, 734, 735, 736, 737, 738, 739, 740, 741, 742, 743, 744, 745, 746, 747, 748, 749, 750, 751, 752, 753, 754, 755, 756, 757, 758, 759, 760, 761, 762, 763, 764, 765, 766, 767, 768, 769, 770, 771, 772, 773, 774, 775, 776, 777, 778, 779, 780, 781, 782, 783, 784, 785, 786, 787, 788, 789, 790, 791, 792, 793, 794, 795, 796, 797, 798, 799, 800, 801, 802, 803, 804, 805, 806, 807, 808, 809, 810, 811, 812, 813, 814, 815, 816, 817, 818, 819, 820, 821, 822, 823, 824, 825, 826, 827, 828, 829, 830, 831, 832, 833, 834, 835, 836, 837, 838, 839, 840, 841, 842, 843, 844, 845, 846, 847, 848, 849, 850, 851, 852, 853, 854, 855, 856, 857, 858, 859, 860, 861, 862, 863, 864, 865, 866, 867, 868, 869, 870, 871, 872, 873, 874, 875, 876, 877, 878, 879, 880, 881, 882, 883, 884, 885, 886, 887, 888, 889, 890, 891, 892, 893, 894, 895, 896, 897, 898, 899, 900, 901, 902, 903, 904, 905, 906, 907, 908, 909, 910, 911, 912, 913, 914, 915, 916, 917, 918, 919, 920, 921, 922, 923, 924, 925, 926, 927, 928, 929, 930, 931, 932, 933, 934, 935, 936, 937, 938, 939, 940, 941, 942, 943, 944, 945, 946, 947, 948, 949, 950, 951, 952, 953, 954, 955, 956, 957, 958, 959, 960, 961, 962, 963, 964, 965, 966, 967, 968, 969, 970, 971, 972, 973, 974, 975, 976, 977, 978, 979, 980, 981, 982, 983, 984, 985, 986, 987, 988, 989, 990, 991, 992, 993, 994, 995, 996, 997, 998, 999, 1000

MAIN CONTRACTOR :
Gammon

STRUCTURAL ENGINEER :
ARUP

FACADE CONSULTANT:
MEINHARDT

NOTE :
 1. ALL DIMENSIONS ARE IN mm.
 2. ALL ELEVATIONS ARE VIEWED FROM OUTSIDE.
 3. ALL DIMENSIONS TO BE VERIFIED ON SITE BEFORE FABRICATION.

LEGEND :
 (x1) — DETAIL MARK NO.
 (x001) — REFER SHEET NO.
 1. F.F.L. -- FINISHED FLOOR LEVEL
 2. S.F.L. -- STRUCTURAL FLOOR LEVEL
 3. (R) -- REVERSED DETAIL

B	04/02/2021	REVISION SUBJECT TO ARCH.COMMENT	Ivan
A	09/12/2020	REVISION SUBJECT TO ARCH.COMMENT	Ivan
NO.	DATE	REVISION	BY

JOB NO. : J-852
 PROJECT :
 PROPOSED RESIDENTIAL DEVELOPMENT
 AT 139 - 147 ARGYLE STREET,
 NKIL 6005, 6035 R.P., 6036 R.P.,
 6037 R.P. & 6038 R.P.

TITLE :
 SCHEDULE FOR Plenum Box
 AT TOWER 1 (22F)

DATE : 05-FEB-20 SCALE : 1:100
 DRAWN BY : MN CHECKED BY : DW

美特鋁質有限公司
MIDI ALUMINIUM FABRICATOR LTD.
 Units 6-8, Sunray Industrial Centre, 1/F
 610 Cha Kwo Ling Road, Kowloon
 Tel:23489211-4 Fax:(852)2727666

WINDOW MARK	
LOCATION	22/F KIT. AT TOWER 1 FLAT A
SECTION	70mm ALUM. SECTION
GLAZING	GL-03
QUANTITY	1
REMARKS	

DWG NO. : J852-SD-PB-4111 REV. : B

ELEVATION

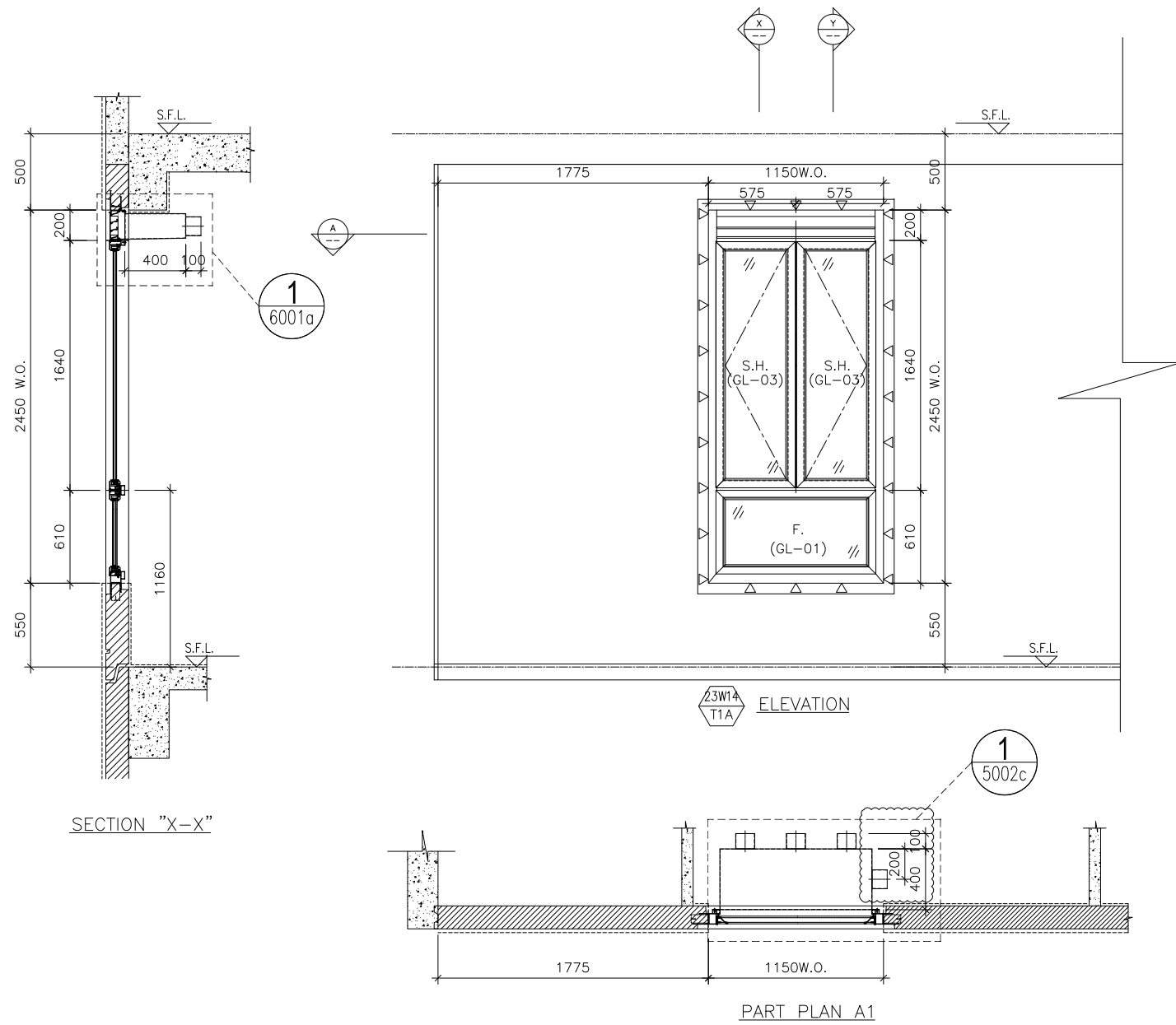

WINDOW MARK	23W14 T1A
LOCATION	23/F M. BATH AT TOWER 1 FLAT A
SECTION	70mm ALUM. SECTION
GLAZING	GL-01, GL-03
QUANTITY	1
REMARKS	FACADE (PF-22)

B.D. REF :

CLIENT :

ARCHITECT :
AGC DESIGN LTD
 101, 102, 103, 104, 105, 106, 107, 108, 109, 110, 111, 112, 113, 114, 115, 116, 117, 118, 119, 120, 121, 122, 123, 124, 125, 126, 127, 128, 129, 130, 131, 132, 133, 134, 135, 136, 137, 138, 139, 140, 141, 142, 143, 144, 145, 146, 147, 148, 149, 150, 151, 152, 153, 154, 155, 156, 157, 158, 159, 160, 161, 162, 163, 164, 165, 166, 167, 168, 169, 170, 171, 172, 173, 174, 175, 176, 177, 178, 179, 180, 181, 182, 183, 184, 185, 186, 187, 188, 189, 190, 191, 192, 193, 194, 195, 196, 197, 198, 199, 200, 201, 202, 203, 204, 205, 206, 207, 208, 209, 210, 211, 212, 213, 214, 215, 216, 217, 218, 219, 220, 221, 222, 223, 224, 225, 226, 227, 228, 229, 230, 231, 232, 233, 234, 235, 236, 237, 238, 239, 240, 241, 242, 243, 244, 245, 246, 247, 248, 249, 250, 251, 252, 253, 254, 255, 256, 257, 258, 259, 260, 261, 262, 263, 264, 265, 266, 267, 268, 269, 270, 271, 272, 273, 274, 275, 276, 277, 278, 279, 280, 281, 282, 283, 284, 285, 286, 287, 288, 289, 290, 291, 292, 293, 294, 295, 296, 297, 298, 299, 300, 301, 302, 303, 304, 305, 306, 307, 308, 309, 310, 311, 312, 313, 314, 315, 316, 317, 318, 319, 320, 321, 322, 323, 324, 325, 326, 327, 328, 329, 330, 331, 332, 333, 334, 335, 336, 337, 338, 339, 340, 341, 342, 343, 344, 345, 346, 347, 348, 349, 350, 351, 352, 353, 354, 355, 356, 357, 358, 359, 360, 361, 362, 363, 364, 365, 366, 367, 368, 369, 370, 371, 372, 373, 374, 375, 376, 377, 378, 379, 380, 381, 382, 383, 384, 385, 386, 387, 388, 389, 390, 391, 392, 393, 394, 395, 396, 397, 398, 399, 400, 401, 402, 403, 404, 405, 406, 407, 408, 409, 410, 411, 412, 413, 414, 415, 416, 417, 418, 419, 420, 421, 422, 423, 424, 425, 426, 427, 428, 429, 430, 431, 432, 433, 434, 435, 436, 437, 438, 439, 440, 441, 442, 443, 444, 445, 446, 447, 448, 449, 450, 451, 452, 453, 454, 455, 456, 457, 458, 459, 460, 461, 462, 463, 464, 465, 466, 467, 468, 469, 470, 471, 472, 473, 474, 475, 476, 477, 478, 479, 480, 481, 482, 483, 484, 485, 486, 487, 488, 489, 490, 491, 492, 493, 494, 495, 496, 497, 498, 499, 500, 501, 502, 503, 504, 505, 506, 507, 508, 509, 510, 511, 512, 513, 514, 515, 516, 517, 518, 519, 520, 521, 522, 523, 524, 525, 526, 527, 528, 529, 530, 531, 532, 533, 534, 535, 536, 537, 538, 539, 540, 541, 542, 543, 544, 545, 546, 547, 548, 549, 550, 551, 552, 553, 554, 555, 556, 557, 558, 559, 560, 561, 562, 563, 564, 565, 566, 567, 568, 569, 570, 571, 572, 573, 574, 575, 576, 577, 578, 579, 580, 581, 582, 583, 584, 585, 586, 587, 588, 589, 590, 591, 592, 593, 594, 595, 596, 597, 598, 599, 600, 601, 602, 603, 604, 605, 606, 607, 608, 609, 610, 611, 612, 613, 614, 615, 616, 617, 618, 619, 620, 621, 622, 623, 624, 625, 626, 627, 628, 629, 630, 631, 632, 633, 634, 635, 636, 637, 638, 639, 640, 641, 642, 643, 644, 645, 646, 647, 648, 649, 650, 651, 652, 653, 654, 655, 656, 657, 658, 659, 660, 661, 662, 663, 664, 665, 666, 667, 668, 669, 670, 671, 672, 673, 674, 675, 676, 677, 678, 679, 680, 681, 682, 683, 684, 685, 686, 687, 688, 689, 690, 691, 692, 693, 694, 695, 696, 697, 698, 699, 700, 701, 702, 703, 704, 705, 706, 707, 708, 709, 710, 711, 712, 713, 714, 715, 716, 717, 718, 719, 720, 721, 722, 723, 724, 725, 726, 727, 728, 729, 730, 731, 732, 733, 734, 735, 736, 737, 738, 739, 740, 741, 742, 743, 744, 745, 746, 747, 748, 749, 750, 751, 752, 753, 754, 755, 756, 757, 758, 759, 760, 761, 762, 763, 764, 765, 766, 767, 768, 769, 770, 771, 772, 773, 774, 775, 776, 777, 778, 779, 780, 781, 782, 783, 784, 785, 786, 787, 788, 789, 790, 791, 792, 793, 794, 795, 796, 797, 798, 799, 800, 801, 802, 803, 804, 805, 806, 807, 808, 809, 810, 811, 812, 813, 814, 815, 816, 817, 818, 819, 820, 821, 822, 823, 824, 825, 826, 827, 828, 829, 830, 831, 832, 833, 834, 835, 836, 837, 838, 839, 840, 841, 842, 843, 844, 845, 846, 847, 848, 849, 850, 851, 852, 853, 854, 855, 856, 857, 858, 859, 860, 861, 862, 863, 864, 865, 866, 867, 868, 869, 870, 871, 872, 873, 874, 875, 876, 877, 878, 879, 880, 881, 882, 883, 884, 885, 886, 887, 888, 889, 890, 891, 892, 893, 894, 895, 896, 897, 898, 899, 900, 901, 902, 903, 904, 905, 906, 907, 908, 909, 910, 911, 912, 913, 914, 915, 916, 917, 918, 919, 920, 921, 922, 923, 924, 925, 926, 927, 928, 929, 930, 931, 932, 933, 934, 935, 936, 937, 938, 939, 940, 941, 942, 943, 944, 945, 946, 947, 948, 949, 950, 951, 952, 953, 954, 955, 956, 957, 958, 959, 960, 961, 962, 963, 964, 965, 966, 967, 968, 969, 970, 971, 972, 973, 974, 975, 976, 977, 978, 979, 980, 981, 982, 983, 984, 985, 986, 987, 988, 989, 990, 991, 992, 993, 994, 995, 996, 997, 998, 999, 1000

NOTE :

- ALL DIMENSIONS ARE IN mm.
- ALL ELEVATIONS ARE VIEWED FROM OUTSIDE.
- ALL DIMENSIONS TO BE VERIFIED ON SITE BEFORE FABRICATION.

LEGEND :

x1 --- DETAIL MARK NO.
 x001 --- REFER SHEET NO.

- F.F.L. --- FINISHED FLOOR LEVEL
- S.F.L. --- STRUCTURAL FLOOR LEVEL
- ⊗ --- REVERSED DETAIL
- ▲ --- FIXING LOCATION
- △ --- FIXING LUG LOCATION

GLASS LEGEND

GL01 --- 8mm+12mm AIR GAP+10mm THK. I.G.U.
 GL01a --- 8mm+9mm AIR GAP+12mm THK. I.G.U.
 GL03 --- 6mm+12mm AIR GAP+6mm THK. I.G.U.
 GL04 --- 10mm THK. TEMPERED GLASS (PROTECTIVE BARRIER)
 GL05 --- 6mm+12mm AIR GAP+8mm THK. I.G.U.

B	06/01/2021	REVISION SUBJECT TO ARCH.COMMENT	Ivan
A	09/12/2020	REVISION SUBJECT TO ARCH.COMMENT	Ivan
NO.	DATE	REVISED	BY

JOB NO. : J-852

PROJECT :
 PROPOSED RESIDENTIAL DEVELOPMENT
 AT 139 - 147 ARGYLE STREET,
 NKIL 6005, 6035 R.P., 6036 R.P.,
 6037 R.P. & 6038 R.P.

TITLE :
 SCHEDULE FOR Plenum Box
 AT TOWER 1 (23F)

DATE : 05-Dec-19 SCALE : 1:40

DRAWN BY : MN CHECKED BY : DW

美特鋁質有限公司
MIDI ALUMINIUM FABRICATOR LTD.
 Units 6-8, Sunray Industrial Centre, 1/F
 610 Cha Kwo Ling Road, Kowloon
 Tel:23489211-4 Fax:(852)2727666

DWG NO. : J852-SD-PB-4112 REV. : B

ELEVATION

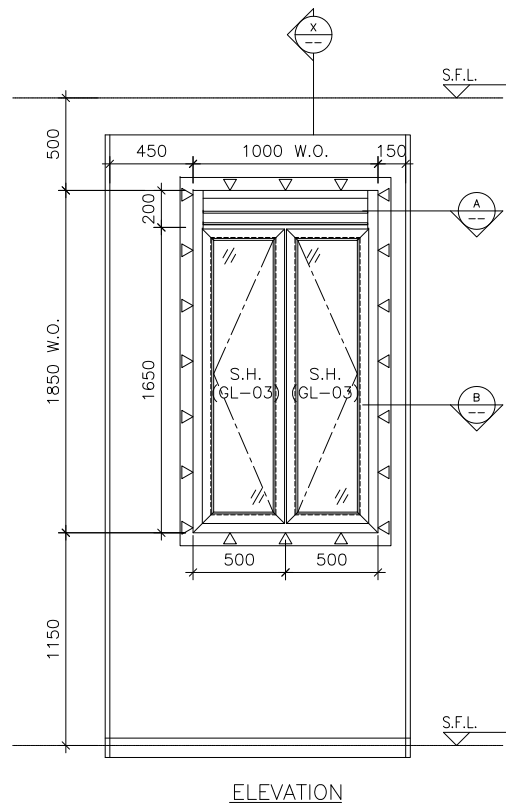

ELEVATION

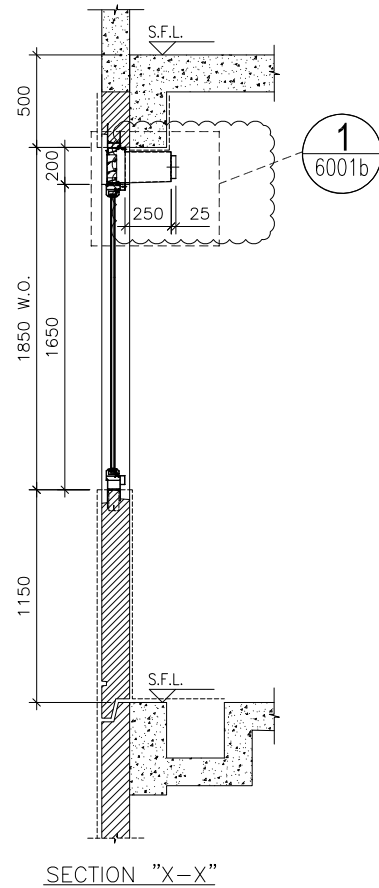

SECTION "X-X"

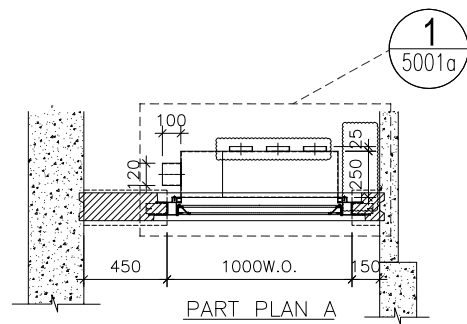

PART PLAN A

WINDOW MARK



LOCATION 23/F KIT. AT TOWER 1 FLAT C

SECTION 70mm ALUM. SECTION

GLAZING GL-03

QUANTITY 1

REMARKS FACADE (PF-31)

B.D. REF :

CLIENT :

ARCHITECT :
AGC DESIGN LTD
 101, 102, 103, 104, 105, 106, 107, 108, 109, 110, 111, 112, 113, 114, 115, 116, 117, 118, 119, 120, 121, 122, 123, 124, 125, 126, 127, 128, 129, 130, 131, 132, 133, 134, 135, 136, 137, 138, 139, 140, 141, 142, 143, 144, 145, 146, 147, 148, 149, 150, 151, 152, 153, 154, 155, 156, 157, 158, 159, 160, 161, 162, 163, 164, 165, 166, 167, 168, 169, 170, 171, 172, 173, 174, 175, 176, 177, 178, 179, 180, 181, 182, 183, 184, 185, 186, 187, 188, 189, 190, 191, 192, 193, 194, 195, 196, 197, 198, 199, 200, 201, 202, 203, 204, 205, 206, 207, 208, 209, 210, 211, 212, 213, 214, 215, 216, 217, 218, 219, 220, 221, 222, 223, 224, 225, 226, 227, 228, 229, 230, 231, 232, 233, 234, 235, 236, 237, 238, 239, 240, 241, 242, 243, 244, 245, 246, 247, 248, 249, 250, 251, 252, 253, 254, 255, 256, 257, 258, 259, 260, 261, 262, 263, 264, 265, 266, 267, 268, 269, 270, 271, 272, 273, 274, 275, 276, 277, 278, 279, 280, 281, 282, 283, 284, 285, 286, 287, 288, 289, 290, 291, 292, 293, 294, 295, 296, 297, 298, 299, 300, 301, 302, 303, 304, 305, 306, 307, 308, 309, 310, 311, 312, 313, 314, 315, 316, 317, 318, 319, 320, 321, 322, 323, 324, 325, 326, 327, 328, 329, 330, 331, 332, 333, 334, 335, 336, 337, 338, 339, 340, 341, 342, 343, 344, 345, 346, 347, 348, 349, 350, 351, 352, 353, 354, 355, 356, 357, 358, 359, 360, 361, 362, 363, 364, 365, 366, 367, 368, 369, 370, 371, 372, 373, 374, 375, 376, 377, 378, 379, 380, 381, 382, 383, 384, 385, 386, 387, 388, 389, 390, 391, 392, 393, 394, 395, 396, 397, 398, 399, 400, 401, 402, 403, 404, 405, 406, 407, 408, 409, 410, 411, 412, 413, 414, 415, 416, 417, 418, 419, 420, 421, 422, 423, 424, 425, 426, 427, 428, 429, 430, 431, 432, 433, 434, 435, 436, 437, 438, 439, 440, 441, 442, 443, 444, 445, 446, 447, 448, 449, 450, 451, 452, 453, 454, 455, 456, 457, 458, 459, 460, 461, 462, 463, 464, 465, 466, 467, 468, 469, 470, 471, 472, 473, 474, 475, 476, 477, 478, 479, 480, 481, 482, 483, 484, 485, 486, 487, 488, 489, 490, 491, 492, 493, 494, 495, 496, 497, 498, 499, 500, 501, 502, 503, 504, 505, 506, 507, 508, 509, 510, 511, 512, 513, 514, 515, 516, 517, 518, 519, 520, 521, 522, 523, 524, 525, 526, 527, 528, 529, 530, 531, 532, 533, 534, 535, 536, 537, 538, 539, 540, 541, 542, 543, 544, 545, 546, 547, 548, 549, 550, 551, 552, 553, 554, 555, 556, 557, 558, 559, 560, 561, 562, 563, 564, 565, 566, 567, 568, 569, 570, 571, 572, 573, 574, 575, 576, 577, 578, 579, 580, 581, 582, 583, 584, 585, 586, 587, 588, 589, 590, 591, 592, 593, 594, 595, 596, 597, 598, 599, 600, 601, 602, 603, 604, 605, 606, 607, 608, 609, 610, 611, 612, 613, 614, 615, 616, 617, 618, 619, 620, 621, 622, 623, 624, 625, 626, 627, 628, 629, 630, 631, 632, 633, 634, 635, 636, 637, 638, 639, 640, 641, 642, 643, 644, 645, 646, 647, 648, 649, 650, 651, 652, 653, 654, 655, 656, 657, 658, 659, 660, 661, 662, 663, 664, 665, 666, 667, 668, 669, 670, 671, 672, 673, 674, 675, 676, 677, 678, 679, 680, 681, 682, 683, 684, 685, 686, 687, 688, 689, 690, 691, 692, 693, 694, 695, 696, 697, 698, 699, 700, 701, 702, 703, 704, 705, 706, 707, 708, 709, 710, 711, 712, 713, 714, 715, 716, 717, 718, 719, 720, 721, 722, 723, 724, 725, 726, 727, 728, 729, 730, 731, 732, 733, 734, 735, 736, 737, 738, 739, 740, 741, 742, 743, 744, 745, 746, 747, 748, 749, 750, 751, 752, 753, 754, 755, 756, 757, 758, 759, 760, 761, 762, 763, 764, 765, 766, 767, 768, 769, 770, 771, 772, 773, 774, 775, 776, 777, 778, 779, 780, 781, 782, 783, 784, 785, 786, 787, 788, 789, 790, 791, 792, 793, 794, 795, 796, 797, 798, 799, 800, 801, 802, 803, 804, 805, 806, 807, 808, 809, 810, 811, 812, 813, 814, 815, 816, 817, 818, 819, 820, 821, 822, 823, 824, 825, 826, 827, 828, 829, 830, 831, 832, 833, 834, 835, 836, 837, 838, 839, 840, 841, 842, 843, 844, 845, 846, 847, 848, 849, 850, 851, 852, 853, 854, 855, 856, 857, 858, 859, 860, 861, 862, 863, 864, 865, 866, 867, 868, 869, 870, 871, 872, 873, 874, 875, 876, 877, 878, 879, 880, 881, 882, 883, 884, 885, 886, 887, 888, 889, 890, 891, 892, 893, 894, 895, 896, 897, 898, 899, 900, 901, 902, 903, 904, 905, 906, 907, 908, 909, 910, 911, 912, 913, 914, 915, 916, 917, 918, 919, 920, 921, 922, 923, 924, 925, 926, 927, 928, 929, 930, 931, 932, 933, 934, 935, 936, 937, 938, 939, 940, 941, 942, 943, 944, 945, 946, 947, 948, 949, 950, 951, 952, 953, 954, 955, 956, 957, 958, 959, 960, 961, 962, 963, 964, 965, 966, 967, 968, 969, 970, 971, 972, 973, 974, 975, 976, 977, 978, 979, 980, 981, 982, 983, 984, 985, 986, 987, 988, 989, 990, 991, 992, 993, 994, 995, 996, 997, 998, 999, 1000

MAIN CONTRACTOR :
Gammon

STRUCTURAL ENGINEER :
ARUP

FACADE CONSULTANT:
MEINHARDT

NOTE :
 1. ALL DIMENSIONS ARE IN mm.
 2. ALL ELEVATIONS ARE VIEWED FROM OUTSIDE.
 3. ALL DIMENSIONS TO BE VERIFIED ON SITE BEFORE FABRICATION.

LEGEND :
 (x1) --- DETAIL MARK NO.
 (x001) --- REFER SHEET NO.
 1. F.F.L. --- FINISHED FLOOR LEVEL
 2. S.F.L. --- STRUCTURAL FLOOR LEVEL
 3. (R) --- REVERSED DETAIL
 4. ▲ --- FIXING LOCATION
 5. △ --- FIXING LUG LOCATION
 6. GLASS LEGEND
 GL01 --- 8mm+12mm AIR GAP+10mm THK. I.G.U.
 GL01a --- 8mm+9mm AIR GAP+12mm THK. I.G.U.
 GL03 --- 6mm+12mm AIR GAP+6mm THK. I.G.U.
 GL04 --- 10mm THK. TEMPERED GLASS (PROTECTIVE BARRIER)
 GL05 --- 6mm+12mm AIR GAP+8mm THK. I.G.U.

C	05/03/2021	REVISION SUBJECT TO ARCH.COMMENT	Ivan
B	06/01/2021	REVISION SUBJECT TO ARCH.COMMENT	Ivan
A	09/12/2020	REVISION SUBJECT TO ARCH.COMMENT	Ivan
NO.	DATE	REVISED	BY

JOB NO. : J-852
 PROJECT :
 PROPOSED RESIDENTIAL DEVELOPMENT
 AT 139 - 147 ARGYLE STREET,
 NKIL 6005, 6035 R.P., 6036 R.P.,
 6037 R.P. & 6038 R.P.

TITLE :
 SCHEDULE FOR Plenum Box
 AT TOWER 1 (23F)

DATE : 05-Dec-19 SCALE : 1:40
 DRAWN BY : MN CHECKED BY : DW

美特鋁質有限公司
MIDI ALUMINIUM FABRICATOR LTD.
 Units 6-8, Sunray Industrial Centre, 1/F
 610 Cha Kwo Ling Road, Kowloon
 Tel:23489211-4 Fax:(852)27727666
 DWG NO. : J852-SD-PB-4113 REV. : C

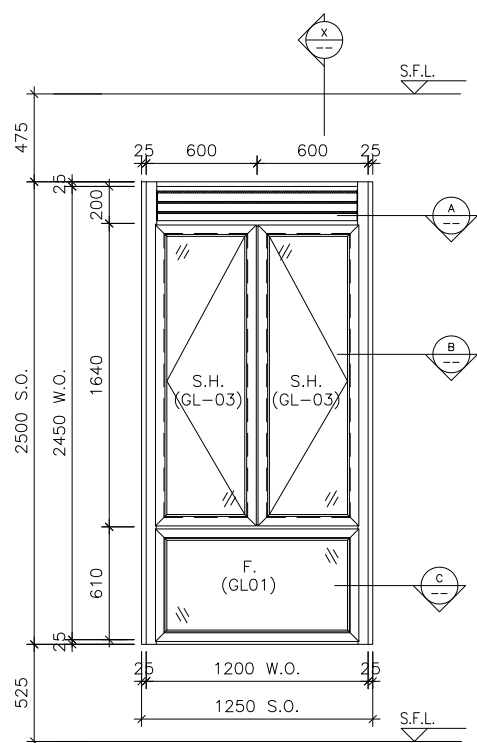

ELEVATION

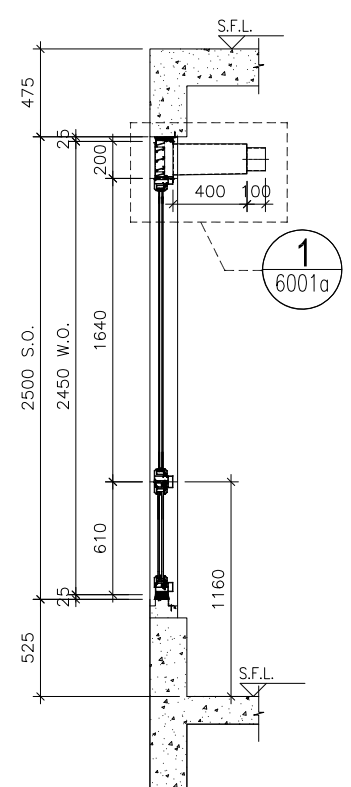

SECTION "X-X"

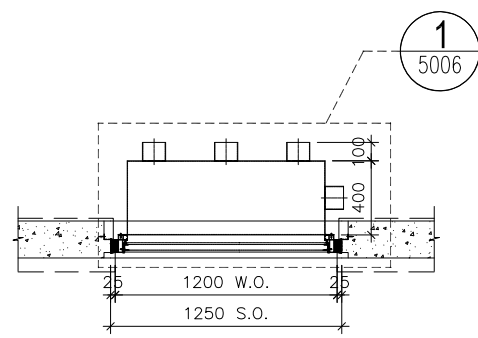

PART PLAN A

ELEVATION

B.D. REF :

CLIENT :

ARCHITECT :
AGC DESIGN LTD
 101, 102, 103, 104, 105, 106, 107, 108, 109, 110, 111, 112, 113, 114, 115, 116, 117, 118, 119, 120, 121, 122, 123, 124, 125, 126, 127, 128, 129, 130, 131, 132, 133, 134, 135, 136, 137, 138, 139, 140, 141, 142, 143, 144, 145, 146, 147, 148, 149, 150, 151, 152, 153, 154, 155, 156, 157, 158, 159, 160, 161, 162, 163, 164, 165, 166, 167, 168, 169, 170, 171, 172, 173, 174, 175, 176, 177, 178, 179, 180, 181, 182, 183, 184, 185, 186, 187, 188, 189, 190, 191, 192, 193, 194, 195, 196, 197, 198, 199, 200

MAIN CONTRACTOR :
Gammon

STRUCTURAL ENGINEER :
ARUP

FACADE CONSULTANT:
MEINHARDT

NOTE :
 1. ALL DIMENSIONS ARE IN mm.
 2. ALL ELEVATIONS ARE VIEWED FROM OUTSIDE.
 3. ALL DIMENSIONS TO BE VERIFIED ON SITE BEFORE FABRICATION.

LEGEND :
 (X1) --- DETAIL MARK NO.
 (X001) --- REFER SHEET NO.
 1. F.F.L. --- FINISHED FLOOR LEVEL
 2. S.F.L. --- STRUCTURAL FLOOR LEVEL
 3. (R) --- REVERSED DETAIL

NO.	DATE	REVISED	BY
-----	------	---------	----

JOB NO. : J-852
 PROJECT : PROPOSED RESIDENTIAL DEVELOPMENT AT 139 - 147 ARGYLE STREET, NKIL 6005, 6035 R.P., 6036 R.P., 6037 R.P. & 6038 R.P.

TITLE : SCHEDULE FOR Plenum Box AT TOWER 1 (23F)

DATE : 05-FEB-20 SCALE : 1:100

DRAWN BY : MN CHECKED BY : DW

美特鋁質有限公司
MIDI ALUMINIUM FABRICATOR LTD.
 Units 6-8, Sunray Industrial Centre, 1/F
 610 Cha Kwo Ling Road, Kowloon
 Tel:23489211-4 Fax:(852)2727666
 DWG NO. : J852-SD-PB-4114 REV. : -

WINDOW MARK	
LOCATION	23/F BATH AT TOWER 1 FLAT A
SECTION	70mm ALUM. SECTION
GLAZING	GL-01, GL-03
QUANTITY	1
REMARKS	

ELEVATION

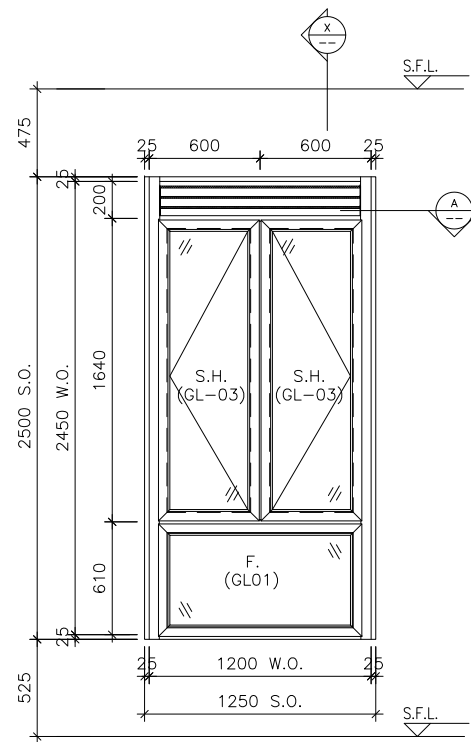

ELEVATION

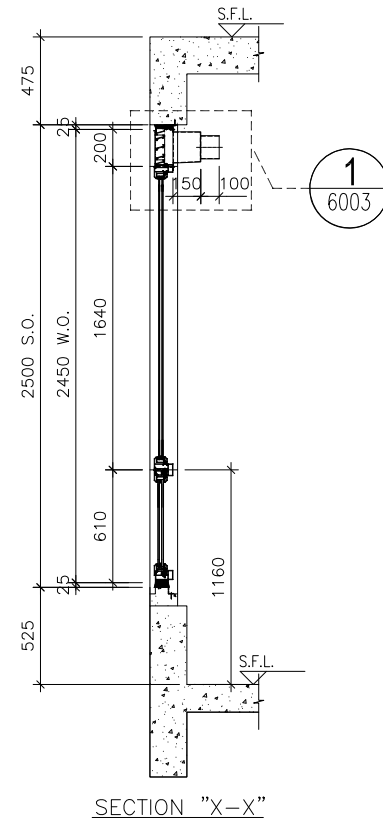

SECTION "X-X"

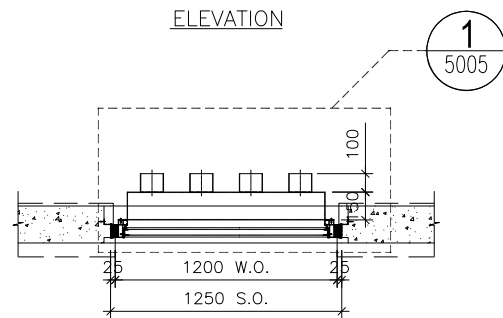

PART PLAN A

WINDOW MARK	
LOCATION	23/F EN. B 3 AT TOWER 1 FLAT A
SECTION	70mm ALUM. SECTION
GLAZING	GL-01, GL-03
QUANTITY	1
REMARKS	

B.D. REF :

CLIENT :

ARCHITECT :
AGC DESIGN LTD
 101, 102, 103, 104, 105, 106, 107, 108, 109, 110, 111, 112, 113, 114, 115, 116, 117, 118, 119, 120, 121, 122, 123, 124, 125, 126, 127, 128, 129, 130, 131, 132, 133, 134, 135, 136, 137, 138, 139, 140, 141, 142, 143, 144, 145, 146, 147, 148, 149, 150, 151, 152, 153, 154, 155, 156, 157, 158, 159, 160, 161, 162, 163, 164, 165, 166, 167, 168, 169, 170, 171, 172, 173, 174, 175, 176, 177, 178, 179, 180, 181, 182, 183, 184, 185, 186, 187, 188, 189, 190, 191, 192, 193, 194, 195, 196, 197, 198, 199, 200, 201, 202, 203, 204, 205, 206, 207, 208, 209, 210, 211, 212, 213, 214, 215, 216, 217, 218, 219, 220, 221, 222, 223, 224, 225, 226, 227, 228, 229, 230, 231, 232, 233, 234, 235, 236, 237, 238, 239, 240, 241, 242, 243, 244, 245, 246, 247, 248, 249, 250, 251, 252, 253, 254, 255, 256, 257, 258, 259, 260, 261, 262, 263, 264, 265, 266, 267, 268, 269, 270, 271, 272, 273, 274, 275, 276, 277, 278, 279, 280, 281, 282, 283, 284, 285, 286, 287, 288, 289, 290, 291, 292, 293, 294, 295, 296, 297, 298, 299, 300, 301, 302, 303, 304, 305, 306, 307, 308, 309, 310, 311, 312, 313, 314, 315, 316, 317, 318, 319, 320, 321, 322, 323, 324, 325, 326, 327, 328, 329, 330, 331, 332, 333, 334, 335, 336, 337, 338, 339, 340, 341, 342, 343, 344, 345, 346, 347, 348, 349, 350, 351, 352, 353, 354, 355, 356, 357, 358, 359, 360, 361, 362, 363, 364, 365, 366, 367, 368, 369, 370, 371, 372, 373, 374, 375, 376, 377, 378, 379, 380, 381, 382, 383, 384, 385, 386, 387, 388, 389, 390, 391, 392, 393, 394, 395, 396, 397, 398, 399, 400, 401, 402, 403, 404, 405, 406, 407, 408, 409, 410, 411, 412, 413, 414, 415, 416, 417, 418, 419, 420, 421, 422, 423, 424, 425, 426, 427, 428, 429, 430, 431, 432, 433, 434, 435, 436, 437, 438, 439, 440, 441, 442, 443, 444, 445, 446, 447, 448, 449, 450, 451, 452, 453, 454, 455, 456, 457, 458, 459, 460, 461, 462, 463, 464, 465, 466, 467, 468, 469, 470, 471, 472, 473, 474, 475, 476, 477, 478, 479, 480, 481, 482, 483, 484, 485, 486, 487, 488, 489, 490, 491, 492, 493, 494, 495, 496, 497, 498, 499, 500, 501, 502, 503, 504, 505, 506, 507, 508, 509, 510, 511, 512, 513, 514, 515, 516, 517, 518, 519, 520, 521, 522, 523, 524, 525, 526, 527, 528, 529, 530, 531, 532, 533, 534, 535, 536, 537, 538, 539, 540, 541, 542, 543, 544, 545, 546, 547, 548, 549, 550, 551, 552, 553, 554, 555, 556, 557, 558, 559, 560, 561, 562, 563, 564, 565, 566, 567, 568, 569, 570, 571, 572, 573, 574, 575, 576, 577, 578, 579, 580, 581, 582, 583, 584, 585, 586, 587, 588, 589, 590, 591, 592, 593, 594, 595, 596, 597, 598, 599, 600, 601, 602, 603, 604, 605, 606, 607, 608, 609, 610, 611, 612, 613, 614, 615, 616, 617, 618, 619, 620, 621, 622, 623, 624, 625, 626, 627, 628, 629, 630, 631, 632, 633, 634, 635, 636, 637, 638, 639, 640, 641, 642, 643, 644, 645, 646, 647, 648, 649, 650, 651, 652, 653, 654, 655, 656, 657, 658, 659, 660, 661, 662, 663, 664, 665, 666, 667, 668, 669, 670, 671, 672, 673, 674, 675, 676, 677, 678, 679, 680, 681, 682, 683, 684, 685, 686, 687, 688, 689, 690, 691, 692, 693, 694, 695, 696, 697, 698, 699, 700, 701, 702, 703, 704, 705, 706, 707, 708, 709, 710, 711, 712, 713, 714, 715, 716, 717, 718, 719, 720, 721, 722, 723, 724, 725, 726, 727, 728, 729, 730, 731, 732, 733, 734, 735, 736, 737, 738, 739, 740, 741, 742, 743, 744, 745, 746, 747, 748, 749, 750, 751, 752, 753, 754, 755, 756, 757, 758, 759, 760, 761, 762, 763, 764, 765, 766, 767, 768, 769, 770, 771, 772, 773, 774, 775, 776, 777, 778, 779, 780, 781, 782, 783, 784, 785, 786, 787, 788, 789, 790, 791, 792, 793, 794, 795, 796, 797, 798, 799, 800, 801, 802, 803, 804, 805, 806, 807, 808, 809, 810, 811, 812, 813, 814, 815, 816, 817, 818, 819, 820, 821, 822, 823, 824, 825, 826, 827, 828, 829, 830, 831, 832, 833, 834, 835, 836, 837, 838, 839, 840, 841, 842, 843, 844, 845, 846, 847, 848, 849, 850, 851, 852, 853, 854, 855, 856, 857, 858, 859, 860, 861, 862, 863, 864, 865, 866, 867, 868, 869, 870, 871, 872, 873, 874, 875, 876, 877, 878, 879, 880, 881, 882, 883, 884, 885, 886, 887, 888, 889, 890, 891, 892, 893, 894, 895, 896, 897, 898, 899, 900, 901, 902, 903, 904, 905, 906, 907, 908, 909, 910, 911, 912, 913, 914, 915, 916, 917, 918, 919, 920, 921, 922, 923, 924, 925, 926, 927, 928, 929, 930, 931, 932, 933, 934, 935, 936, 937, 938, 939, 940, 941, 942, 943, 944, 945, 946, 947, 948, 949, 950, 951, 952, 953, 954, 955, 956, 957, 958, 959, 960, 961, 962, 963, 964, 965, 966, 967, 968, 969, 970, 971, 972, 973, 974, 975, 976, 977, 978, 979, 980, 981, 982, 983, 984, 985, 986, 987, 988, 989, 990, 991, 992, 993, 994, 995, 996, 997, 998, 999, 1000

MAIN CONTRACTOR :
Gammon

STRUCTURAL ENGINEER :
ARUP

FACADE CONSULTANT:
MEINHARDT

NOTE :
 1. ALL DIMENSIONS ARE IN mm.
 2. ALL ELEVATIONS ARE VIEWED FROM OUTSIDE.
 3. ALL DIMENSIONS TO BE VERIFIED ON SITE BEFORE FABRICATION.

LEGEND :

 1. F.F.L. -- FINISHED FLOOR LEVEL
 2. S.F.L. -- STRUCTURAL FLOOR LEVEL
 3. (R) -- REVERSED DETAIL

NO.	DATE	REVISED	BY
-----	------	---------	----

JOB NO. : J-852
 PROJECT : PROPOSED RESIDENTIAL DEVELOPMENT AT 139 - 147 ARGYLE STREET, NKIL 6005, 6035 R.P., 6036 R.P., 6037 R.P. & 6038 R.P.

TITLE : SCHEDULE FOR Plenum Box AT TOWER 1 (23F)

DATE : 05-FEB-20 SCALE : 1:100
 DRAWN BY : MN CHECKED BY : DW

美特鋁質有限公司
MIDI ALUMINIUM FABRICATOR LTD.
 Units 6-8, Sunray Industrial Centre, 1/F
 610 Cha Kwo Ling Road, Kowloon
 Tel:23489211-4 Fax:(852)2727666
 DWG NO. : J852-SD-PB-4115 REV. : -

ELEVATION

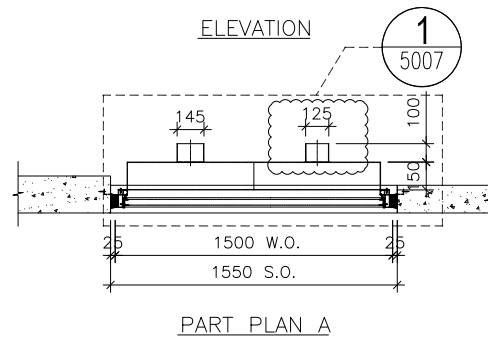
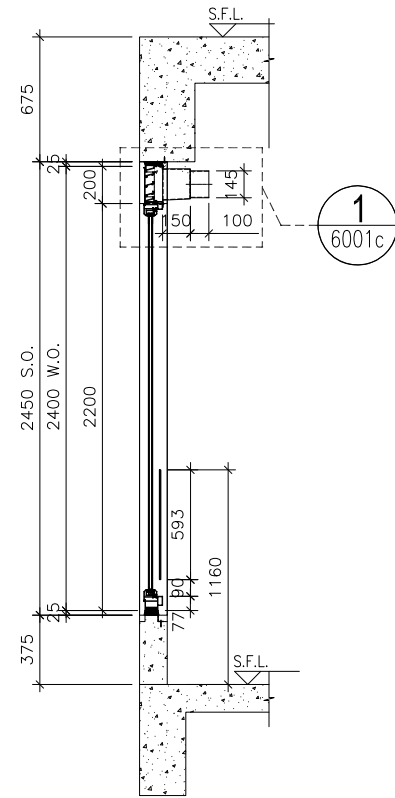
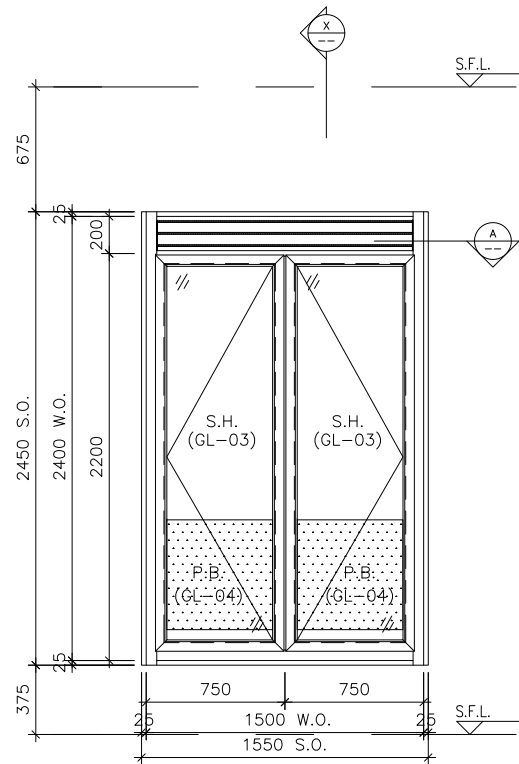

SECTION "X-X"

PART PLAN A

WINDOW MARK	
LOCATION	23/F KIT. AT TOWER 1 FLAT A
SECTION	70mm ALUM. SECTION
GLAZING	GL-01, GL-03
QUANTITY	1
REMARKS	

B.D. REF :

CLIENT :

ARCHITECT :
AGC DESIGN LTD
 101, 102, 103, 104, 105, 106, 107, 108, 109, 110, 111, 112, 113, 114, 115, 116, 117, 118, 119, 120, 121, 122, 123, 124, 125, 126, 127, 128, 129, 130, 131, 132, 133, 134, 135, 136, 137, 138, 139, 140, 141, 142, 143, 144, 145, 146, 147, 148, 149, 150, 151, 152, 153, 154, 155, 156, 157, 158, 159, 160, 161, 162, 163, 164, 165, 166, 167, 168, 169, 170, 171, 172, 173, 174, 175, 176, 177, 178, 179, 180, 181, 182, 183, 184, 185, 186, 187, 188, 189, 190, 191, 192, 193, 194, 195, 196, 197, 198, 199, 200, 201, 202, 203, 204, 205, 206, 207, 208, 209, 210, 211, 212, 213, 214, 215, 216, 217, 218, 219, 220, 221, 222, 223, 224, 225, 226, 227, 228, 229, 230, 231, 232, 233, 234, 235, 236, 237, 238, 239, 240, 241, 242, 243, 244, 245, 246, 247, 248, 249, 250, 251, 252, 253, 254, 255, 256, 257, 258, 259, 260, 261, 262, 263, 264, 265, 266, 267, 268, 269, 270, 271, 272, 273, 274, 275, 276, 277, 278, 279, 280, 281, 282, 283, 284, 285, 286, 287, 288, 289, 290, 291, 292, 293, 294, 295, 296, 297, 298, 299, 300, 301, 302, 303, 304, 305, 306, 307, 308, 309, 310, 311, 312, 313, 314, 315, 316, 317, 318, 319, 320, 321, 322, 323, 324, 325, 326, 327, 328, 329, 330, 331, 332, 333, 334, 335, 336, 337, 338, 339, 340, 341, 342, 343, 344, 345, 346, 347, 348, 349, 350, 351, 352, 353, 354, 355, 356, 357, 358, 359, 360, 361, 362, 363, 364, 365, 366, 367, 368, 369, 370, 371, 372, 373, 374, 375, 376, 377, 378, 379, 380, 381, 382, 383, 384, 385, 386, 387, 388, 389, 390, 391, 392, 393, 394, 395, 396, 397, 398, 399, 400, 401, 402, 403, 404, 405, 406, 407, 408, 409, 410, 411, 412, 413, 414, 415, 416, 417, 418, 419, 420, 421, 422, 423, 424, 425, 426, 427, 428, 429, 430, 431, 432, 433, 434, 435, 436, 437, 438, 439, 440, 441, 442, 443, 444, 445, 446, 447, 448, 449, 450, 451, 452, 453, 454, 455, 456, 457, 458, 459, 460, 461, 462, 463, 464, 465, 466, 467, 468, 469, 470, 471, 472, 473, 474, 475, 476, 477, 478, 479, 480, 481, 482, 483, 484, 485, 486, 487, 488, 489, 490, 491, 492, 493, 494, 495, 496, 497, 498, 499, 500, 501, 502, 503, 504, 505, 506, 507, 508, 509, 510, 511, 512, 513, 514, 515, 516, 517, 518, 519, 520, 521, 522, 523, 524, 525, 526, 527, 528, 529, 530, 531, 532, 533, 534, 535, 536, 537, 538, 539, 540, 541, 542, 543, 544, 545, 546, 547, 548, 549, 550, 551, 552, 553, 554, 555, 556, 557, 558, 559, 560, 561, 562, 563, 564, 565, 566, 567, 568, 569, 570, 571, 572, 573, 574, 575, 576, 577, 578, 579, 580, 581, 582, 583, 584, 585, 586, 587, 588, 589, 590, 591, 592, 593, 594, 595, 596, 597, 598, 599, 600, 601, 602, 603, 604, 605, 606, 607, 608, 609, 610, 611, 612, 613, 614, 615, 616, 617, 618, 619, 620, 621, 622, 623, 624, 625, 626, 627, 628, 629, 630, 631, 632, 633, 634, 635, 636, 637, 638, 639, 640, 641, 642, 643, 644, 645, 646, 647, 648, 649, 650, 651, 652, 653, 654, 655, 656, 657, 658, 659, 660, 661, 662, 663, 664, 665, 666, 667, 668, 669, 670, 671, 672, 673, 674, 675, 676, 677, 678, 679, 680, 681, 682, 683, 684, 685, 686, 687, 688, 689, 690, 691, 692, 693, 694, 695, 696, 697, 698, 699, 700, 701, 702, 703, 704, 705, 706, 707, 708, 709, 710, 711, 712, 713, 714, 715, 716, 717, 718, 719, 720, 721, 722, 723, 724, 725, 726, 727, 728, 729, 730, 731, 732, 733, 734, 735, 736, 737, 738, 739, 740, 741, 742, 743, 744, 745, 746, 747, 748, 749, 750, 751, 752, 753, 754, 755, 756, 757, 758, 759, 760, 761, 762, 763, 764, 765, 766, 767, 768, 769, 770, 771, 772, 773, 774, 775, 776, 777, 778, 779, 780, 781, 782, 783, 784, 785, 786, 787, 788, 789, 790, 791, 792, 793, 794, 795, 796, 797, 798, 799, 800, 801, 802, 803, 804, 805, 806, 807, 808, 809, 810, 811, 812, 813, 814, 815, 816, 817, 818, 819, 820, 821, 822, 823, 824, 825, 826, 827, 828, 829, 830, 831, 832, 833, 834, 835, 836, 837, 838, 839, 840, 841, 842, 843, 844, 845, 846, 847, 848, 849, 850, 851, 852, 853, 854, 855, 856, 857, 858, 859, 860, 861, 862, 863, 864, 865, 866, 867, 868, 869, 870, 871, 872, 873, 874, 875, 876, 877, 878, 879, 880, 881, 882, 883, 884, 885, 886, 887, 888, 889, 890, 891, 892, 893, 894, 895, 896, 897, 898, 899, 900, 901, 902, 903, 904, 905, 906, 907, 908, 909, 910, 911, 912, 913, 914, 915, 916, 917, 918, 919, 920, 921, 922, 923, 924, 925, 926, 927, 928, 929, 930, 931, 932, 933, 934, 935, 936, 937, 938, 939, 940, 941, 942, 943, 944, 945, 946, 947, 948, 949, 950, 951, 952, 953, 954, 955, 956, 957, 958, 959, 960, 961, 962, 963, 964, 965, 966, 967, 968, 969, 970, 971, 972, 973, 974, 975, 976, 977, 978, 979, 980, 981, 982, 983, 984, 985, 986, 987, 988, 989, 990, 991, 992, 993, 994, 995, 996, 997, 998, 999, 1000

MAIN CONTRACTOR :
Gammon

STRUCTURAL ENGINEER :
ARUP

FACADE CONSULTANT:
MEINHARDT

NOTE :
 1. ALL DIMENSIONS ARE IN mm.
 2. ALL ELEVATIONS ARE VIEWED FROM OUTSIDE.
 3. ALL DIMENSIONS TO BE VERIFIED ON SITE BEFORE FABRICATION.

LEGEND :
 (X1) --- DETAIL MARK NO.
 (X001) --- REFER SHEET NO.
 1. F.F.L. --- FINISHED FLOOR LEVEL
 2. S.F.L. --- STRUCTURAL FLOOR LEVEL
 3. (R) --- REVERSED DETAIL

NO.	DATE	REVISION	BY
A	06/01/2021	REVISION SUBJECT TO ARCH.COMMENT	Ivan

JOB NO. : J-852
 PROJECT : PROPOSED RESIDENTIAL DEVELOPMENT AT 139 - 147 ARGYLE STREET, NKIL 6005, 6035 R.P., 6036 R.P., 6037 R.P. & 6038 R.P.
 TITLE : SCHEDULE FOR Plenum Box AT TOWER 1 (23F)

DATE : 05-FEB-20 SCALE : 1:100
 DRAWN BY : MN CHECKED BY : DW

美特鋁質有限公司
MIDI ALUMINIUM FABRICATOR LTD.
 Units 6-8, Sunray Industrial Centre, 1/F
 610 Cha Kwo Ling Road, Kowloon
 Tel:23489211-4 Fax:(852)2727666
 DWG NO. : J852-SD-PB-4116 REV. : A

ELEVATION

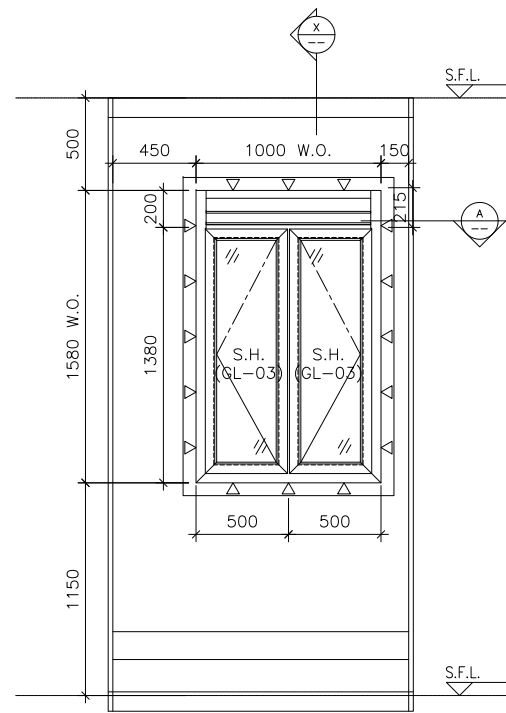

ELEVATION

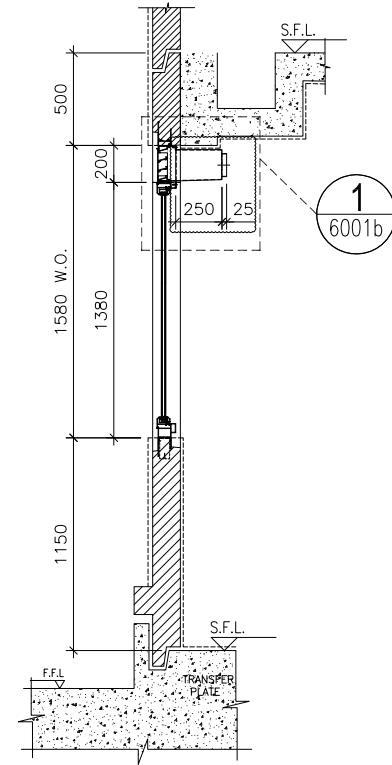

SECTION "X-X"

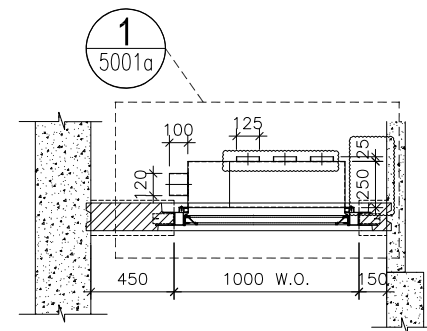

PART PLAN A

WINDOW MARK



LOCATION 1/F KIT. AT TOWER 2 FLAT C

SECTION 70mm ALUM. SECTION

GLAZING GL-03

QUANTITY 1

REMARKS FACADE (PF-28)

B.D. REF :

CLIENT :

ARCHITECT :

AGC
DESIGN LTD

MAIN CONTRACTOR :

Gammon

STRUCTURAL ENGINEER :

ARUP

FACADE CONSULTANT:

MEINHARDT

NOTE :

1. ALL DIMENSIONS ARE IN mm.
2. ALL ELEVATIONS ARE VIEWED FROM OUTSIDE.
3. ALL DIMENSIONS TO BE VERIFIED ON SITE BEFORE FABRICATION.

LEGEND :

- x1 — DETAIL MARK NO.
- x001 — REFER SHEET NO.

1. F.F.L. -- FINISHED FLOOR LEVEL
2. S.F.L. -- STRUCTURAL FLOOR LEVEL
3. (R) -- REVERSED DETAIL
4. ▲ -- FIXING LOCATION
5. △ -- FIXING LUG LOCATION

6. GLASS LEGEND

- GL01 -- 8mm+12mm AIR GAP+10mm THK. I.G.U.
- GL01a -- 8mm+9mm AIR GAP+10mm THK. I.G.U.
- GL03 -- 6mm+12mm AIR GAP+6mm THK. I.G.U.
- GL04 -- 10mm THK. TEMPERED GLASS (PROTECTIVE BARRIER)
- GL05 -- 6mm+12mm AIR GAP+8mm THK. I.G.U.

NO.	DATE	REVISION	BY
C	05/03/2021	REVISION SUBJECT TO ARCH.COMMENT	Ivan
B	06/01/2021	REVISION SUBJECT TO ARCH.COMMENT	Ivan
A	09/12/2020	REVISION SUBJECT TO ARCH.COMMENT	Ivan

JOB NO. : J-852

PROJECT :
PROPOSED RESIDENTIAL DEVELOPMENT
AT 139 - 147 ARGYLE STREET,
NKIL 6005, 6035 R.P., 6036 R.P.,
6037 R.P. & 6038 R.P.

TITLE :
SCHEDULE FOR Plenum Box
AT TOWER 2 (1-21F)

DATE : 05-Dec-19

SCALE : 1:40

DRAWN BY : MN

CHECKED BY : DW

美特鋁質有限公司
MIDI ALUMINIUM FABRICATOR LTD.
Units 6-8, Sunray Industrial Centre, 1/F
610 Cha Kwo Ling Road, Kowloon
Tel:23489211-4 Fax:(852)2727666

DWG NO. : J852-SD-PB-4201

REV. : C

ELEVATION

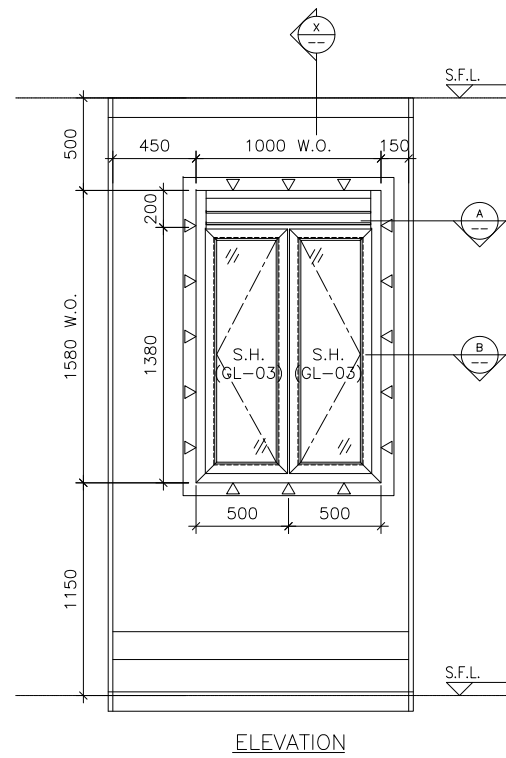

ELEVATION

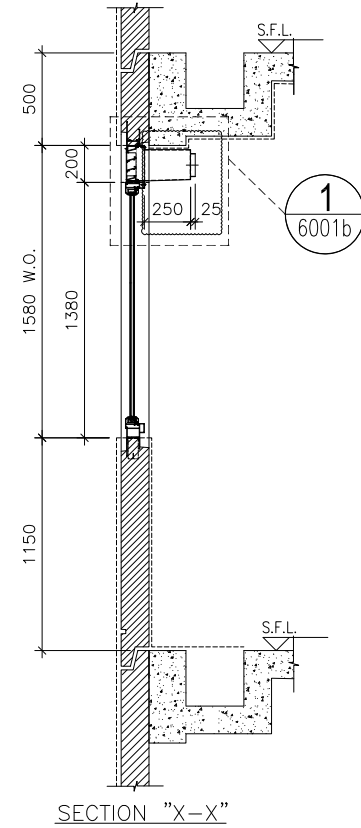

SECTION "X-X"

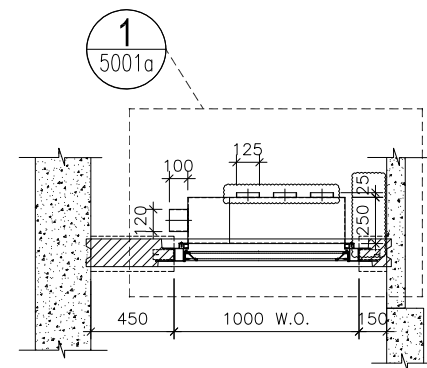

PART PLAN A

WINDOW MARK



LOCATION 2/F-21/F KIT. AT TOWER 2 FLAT C

SECTION 70mm ALUM. SECTION

GLAZING GL-03

QUANTITY 17

REMARKS FACADE (PF-28)

B.D. REF :

CLIENT :

ARCHITECT :
AGC DESIGN LTD
 101, 102, 103, 104, 105, 106, 107, 108, 109, 110, 111, 112, 113, 114, 115, 116, 117, 118, 119, 120, 121, 122, 123, 124, 125, 126, 127, 128, 129, 130, 131, 132, 133, 134, 135, 136, 137, 138, 139, 140, 141, 142, 143, 144, 145, 146, 147, 148, 149, 150, 151, 152, 153, 154, 155, 156, 157, 158, 159, 160, 161, 162, 163, 164, 165, 166, 167, 168, 169, 170, 171, 172, 173, 174, 175, 176, 177, 178, 179, 180, 181, 182, 183, 184, 185, 186, 187, 188, 189, 190, 191, 192, 193, 194, 195, 196, 197, 198, 199, 200, 201, 202, 203, 204, 205, 206, 207, 208, 209, 210, 211, 212, 213, 214, 215, 216, 217, 218, 219, 220, 221, 222, 223, 224, 225, 226, 227, 228, 229, 230, 231, 232, 233, 234, 235, 236, 237, 238, 239, 240, 241, 242, 243, 244, 245, 246, 247, 248, 249, 250, 251, 252, 253, 254, 255, 256, 257, 258, 259, 260, 261, 262, 263, 264, 265, 266, 267, 268, 269, 270, 271, 272, 273, 274, 275, 276, 277, 278, 279, 280, 281, 282, 283, 284, 285, 286, 287, 288, 289, 290, 291, 292, 293, 294, 295, 296, 297, 298, 299, 300, 301, 302, 303, 304, 305, 306, 307, 308, 309, 310, 311, 312, 313, 314, 315, 316, 317, 318, 319, 320, 321, 322, 323, 324, 325, 326, 327, 328, 329, 330, 331, 332, 333, 334, 335, 336, 337, 338, 339, 340, 341, 342, 343, 344, 345, 346, 347, 348, 349, 350, 351, 352, 353, 354, 355, 356, 357, 358, 359, 360, 361, 362, 363, 364, 365, 366, 367, 368, 369, 370, 371, 372, 373, 374, 375, 376, 377, 378, 379, 380, 381, 382, 383, 384, 385, 386, 387, 388, 389, 390, 391, 392, 393, 394, 395, 396, 397, 398, 399, 400, 401, 402, 403, 404, 405, 406, 407, 408, 409, 410, 411, 412, 413, 414, 415, 416, 417, 418, 419, 420, 421, 422, 423, 424, 425, 426, 427, 428, 429, 430, 431, 432, 433, 434, 435, 436, 437, 438, 439, 440, 441, 442, 443, 444, 445, 446, 447, 448, 449, 450, 451, 452, 453, 454, 455, 456, 457, 458, 459, 460, 461, 462, 463, 464, 465, 466, 467, 468, 469, 470, 471, 472, 473, 474, 475, 476, 477, 478, 479, 480, 481, 482, 483, 484, 485, 486, 487, 488, 489, 490, 491, 492, 493, 494, 495, 496, 497, 498, 499, 500, 501, 502, 503, 504, 505, 506, 507, 508, 509, 510, 511, 512, 513, 514, 515, 516, 517, 518, 519, 520, 521, 522, 523, 524, 525, 526, 527, 528, 529, 530, 531, 532, 533, 534, 535, 536, 537, 538, 539, 540, 541, 542, 543, 544, 545, 546, 547, 548, 549, 550, 551, 552, 553, 554, 555, 556, 557, 558, 559, 560, 561, 562, 563, 564, 565, 566, 567, 568, 569, 570, 571, 572, 573, 574, 575, 576, 577, 578, 579, 580, 581, 582, 583, 584, 585, 586, 587, 588, 589, 590, 591, 592, 593, 594, 595, 596, 597, 598, 599, 600, 601, 602, 603, 604, 605, 606, 607, 608, 609, 610, 611, 612, 613, 614, 615, 616, 617, 618, 619, 620, 621, 622, 623, 624, 625, 626, 627, 628, 629, 630, 631, 632, 633, 634, 635, 636, 637, 638, 639, 640, 641, 642, 643, 644, 645, 646, 647, 648, 649, 650, 651, 652, 653, 654, 655, 656, 657, 658, 659, 660, 661, 662, 663, 664, 665, 666, 667, 668, 669, 670, 671, 672, 673, 674, 675, 676, 677, 678, 679, 680, 681, 682, 683, 684, 685, 686, 687, 688, 689, 690, 691, 692, 693, 694, 695, 696, 697, 698, 699, 700, 701, 702, 703, 704, 705, 706, 707, 708, 709, 710, 711, 712, 713, 714, 715, 716, 717, 718, 719, 720, 721, 722, 723, 724, 725, 726, 727, 728, 729, 730, 731, 732, 733, 734, 735, 736, 737, 738, 739, 740, 741, 742, 743, 744, 745, 746, 747, 748, 749, 750, 751, 752, 753, 754, 755, 756, 757, 758, 759, 760, 761, 762, 763, 764, 765, 766, 767, 768, 769, 770, 771, 772, 773, 774, 775, 776, 777, 778, 779, 780, 781, 782, 783, 784, 785, 786, 787, 788, 789, 790, 791, 792, 793, 794, 795, 796, 797, 798, 799, 800, 801, 802, 803, 804, 805, 806, 807, 808, 809, 810, 811, 812, 813, 814, 815, 816, 817, 818, 819, 820, 821, 822, 823, 824, 825, 826, 827, 828, 829, 830, 831, 832, 833, 834, 835, 836, 837, 838, 839, 840, 841, 842, 843, 844, 845, 846, 847, 848, 849, 850, 851, 852, 853, 854, 855, 856, 857, 858, 859, 860, 861, 862, 863, 864, 865, 866, 867, 868, 869, 870, 871, 872, 873, 874, 875, 876, 877, 878, 879, 880, 881, 882, 883, 884, 885, 886, 887, 888, 889, 890, 891, 892, 893, 894, 895, 896, 897, 898, 899, 900, 901, 902, 903, 904, 905, 906, 907, 908, 909, 910, 911, 912, 913, 914, 915, 916, 917, 918, 919, 920, 921, 922, 923, 924, 925, 926, 927, 928, 929, 930, 931, 932, 933, 934, 935, 936, 937, 938, 939, 940, 941, 942, 943, 944, 945, 946, 947, 948, 949, 950, 951, 952, 953, 954, 955, 956, 957, 958, 959, 960, 961, 962, 963, 964, 965, 966, 967, 968, 969, 970, 971, 972, 973, 974, 975, 976, 977, 978, 979, 980, 981, 982, 983, 984, 985, 986, 987, 988, 989, 990, 991, 992, 993, 994, 995, 996, 997, 998, 999, 1000

MAIN CONTRACTOR :
Gammon

STRUCTURAL ENGINEER :
ARUP

FACADE CONSULTANT:
MEINHARDT

NOTE :
 1. ALL DIMENSIONS ARE IN mm.
 2. ALL ELEVATIONS ARE VIEWED FROM OUTSIDE.
 3. ALL DIMENSIONS TO BE VERIFIED ON SITE BEFORE FABRICATION.

LEGEND :
 (x1) --- DETAIL MARK NO.
 (x001) --- REFER SHEET NO.
 1. F.F.L. --- FINISHED FLOOR LEVEL
 2. S.F.L. --- STRUCTURAL FLOOR LEVEL
 3. (R) --- REVERSED DETAIL
 4. ▲ --- FIXING LOCATION
 5. △ --- FIXING LUG LOCATION
 6. GLASS LEGEND
 GL01 --- 8mm+12mm AIR GAP+10mm THK. I.G.U.
 GL01a --- 8mm+9mm AIR GAP+10mm THK. I.G.U.
 GL03 --- 6mm+12mm AIR GAP+6mm THK. I.G.U.
 GL04 --- 10mm THK. TEMPERED GLASS (PROTECTIVE BARRIER)
 GL05 --- 6mm+12mm AIR GAP+8mm THK. I.G.U.

C	05/03/2021	REVISION SUBJECT TO ARCH.COMMENT	Ivan
B	06/01/2021	REVISION SUBJECT TO ARCH.COMMENT	Ivan
A	09/12/2020	REVISION SUBJECT TO ARCH.COMMENT	Ivan
NO.	DATE	REVISED	BY

JOB NO. : J-852
 PROJECT :
 PROPOSED RESIDENTIAL DEVELOPMENT
 AT 139 - 147 ARGYLE STREET,
 NKIL 6005, 6035 R.P., 6036 R.P.,
 6037 R.P. & 6038 R.P.
 TITLE :
 SCHEDULE FOR Plenum Box
 AT TOWER 2 (1-21F)

DATE : 05-Dec-19 SCALE : 1:40
 DRAWN BY : MN CHECKED BY : DW

美特鋁質有限公司
MIDI ALUMINIUM FABRICATOR LTD.
 Units 6-8, Sunray Industrial Centre, 1/F
 610 Cha Kwo Ling Road, Kowloon
 Tel:23489211-4 Fax:(852)27727666

DWG NO. : J852-SD-PB-4201A REV. : C

ELEVATION

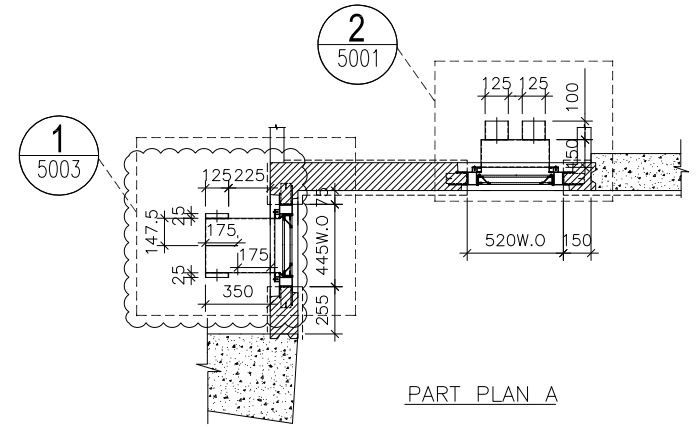
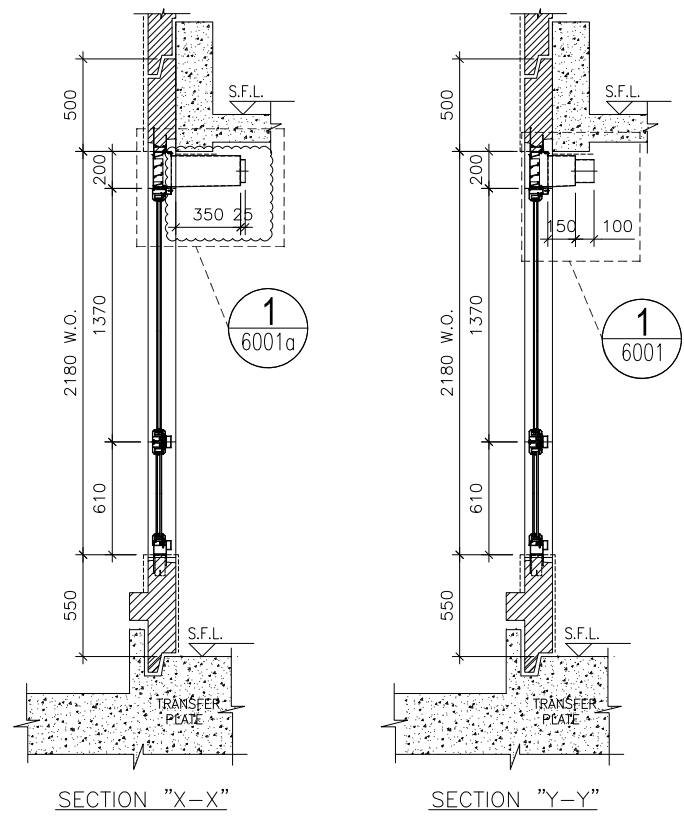
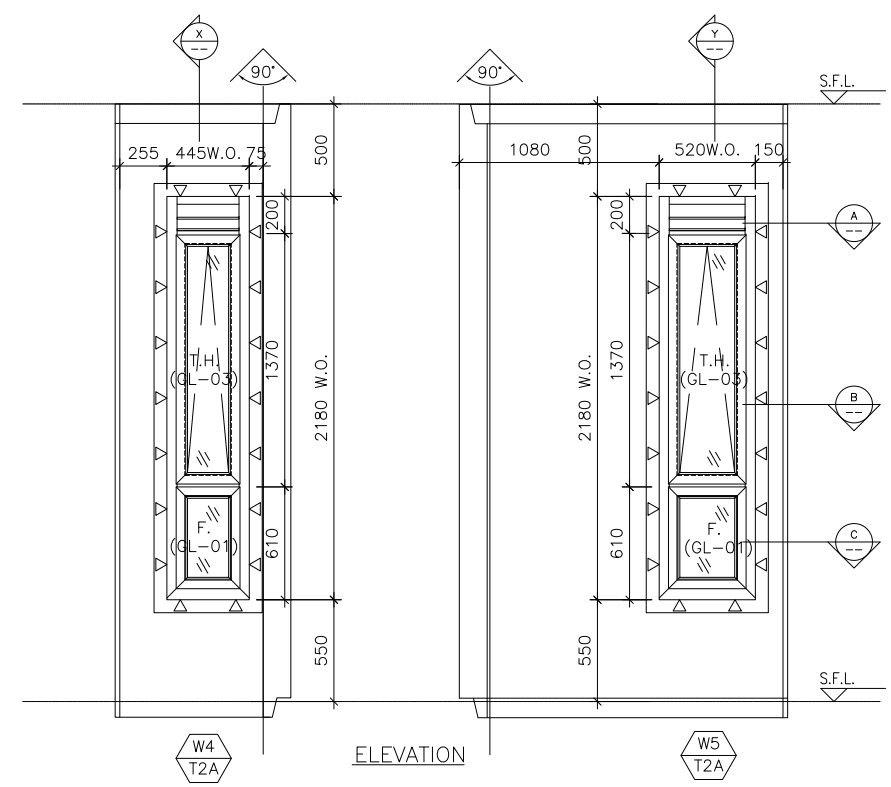

WINDOW MARK	W4 / W5 T2A / T2A
LOCATION	1/F M.B. & EN.B. AT TOWER 2 FLAT A
SECTION	70mm ALUM. SECTION
GLAZING	GL-01, GL-03
QUANTITY	1 / 1
REMARKS	FACADE (PF-35)

B.D. REF :

CLIENT :

ARCHITECT :
AGC DESIGN LTD
 101, 102, 103, 104, 105, 106, 107, 108, 109, 110, 111, 112, 113, 114, 115, 116, 117, 118, 119, 120, 121, 122, 123, 124, 125, 126, 127, 128, 129, 130, 131, 132, 133, 134, 135, 136, 137, 138, 139, 140, 141, 142, 143, 144, 145, 146, 147, 148, 149, 150, 151, 152, 153, 154, 155, 156, 157, 158, 159, 160, 161, 162, 163, 164, 165, 166, 167, 168, 169, 170, 171, 172, 173, 174, 175, 176, 177, 178, 179, 180, 181, 182, 183, 184, 185, 186, 187, 188, 189, 190, 191, 192, 193, 194, 195, 196, 197, 198, 199, 200, 201, 202, 203, 204, 205, 206, 207, 208, 209, 210, 211, 212, 213, 214, 215, 216, 217, 218, 219, 220, 221, 222, 223, 224, 225, 226, 227, 228, 229, 230, 231, 232, 233, 234, 235, 236, 237, 238, 239, 240, 241, 242, 243, 244, 245, 246, 247, 248, 249, 250, 251, 252, 253, 254, 255, 256, 257, 258, 259, 260, 261, 262, 263, 264, 265, 266, 267, 268, 269, 270, 271, 272, 273, 274, 275, 276, 277, 278, 279, 280, 281, 282, 283, 284, 285, 286, 287, 288, 289, 290, 291, 292, 293, 294, 295, 296, 297, 298, 299, 300, 301, 302, 303, 304, 305, 306, 307, 308, 309, 310, 311, 312, 313, 314, 315, 316, 317, 318, 319, 320, 321, 322, 323, 324, 325, 326, 327, 328, 329, 330, 331, 332, 333, 334, 335, 336, 337, 338, 339, 340, 341, 342, 343, 344, 345, 346, 347, 348, 349, 350, 351, 352, 353, 354, 355, 356, 357, 358, 359, 360, 361, 362, 363, 364, 365, 366, 367, 368, 369, 370, 371, 372, 373, 374, 375, 376, 377, 378, 379, 380, 381, 382, 383, 384, 385, 386, 387, 388, 389, 390, 391, 392, 393, 394, 395, 396, 397, 398, 399, 400, 401, 402, 403, 404, 405, 406, 407, 408, 409, 410, 411, 412, 413, 414, 415, 416, 417, 418, 419, 420, 421, 422, 423, 424, 425, 426, 427, 428, 429, 430, 431, 432, 433, 434, 435, 436, 437, 438, 439, 440, 441, 442, 443, 444, 445, 446, 447, 448, 449, 450, 451, 452, 453, 454, 455, 456, 457, 458, 459, 460, 461, 462, 463, 464, 465, 466, 467, 468, 469, 470, 471, 472, 473, 474, 475, 476, 477, 478, 479, 480, 481, 482, 483, 484, 485, 486, 487, 488, 489, 490, 491, 492, 493, 494, 495, 496, 497, 498, 499, 500, 501, 502, 503, 504, 505, 506, 507, 508, 509, 510, 511, 512, 513, 514, 515, 516, 517, 518, 519, 520, 521, 522, 523, 524, 525, 526, 527, 528, 529, 530, 531, 532, 533, 534, 535, 536, 537, 538, 539, 540, 541, 542, 543, 544, 545, 546, 547, 548, 549, 550, 551, 552, 553, 554, 555, 556, 557, 558, 559, 560, 561, 562, 563, 564, 565, 566, 567, 568, 569, 570, 571, 572, 573, 574, 575, 576, 577, 578, 579, 580, 581, 582, 583, 584, 585, 586, 587, 588, 589, 590, 591, 592, 593, 594, 595, 596, 597, 598, 599, 600, 601, 602, 603, 604, 605, 606, 607, 608, 609, 610, 611, 612, 613, 614, 615, 616, 617, 618, 619, 620, 621, 622, 623, 624, 625, 626, 627, 628, 629, 630, 631, 632, 633, 634, 635, 636, 637, 638, 639, 640, 641, 642, 643, 644, 645, 646, 647, 648, 649, 650, 651, 652, 653, 654, 655, 656, 657, 658, 659, 660, 661, 662, 663, 664, 665, 666, 667, 668, 669, 670, 671, 672, 673, 674, 675, 676, 677, 678, 679, 680, 681, 682, 683, 684, 685, 686, 687, 688, 689, 690, 691, 692, 693, 694, 695, 696, 697, 698, 699, 700, 701, 702, 703, 704, 705, 706, 707, 708, 709, 710, 711, 712, 713, 714, 715, 716, 717, 718, 719, 720, 721, 722, 723, 724, 725, 726, 727, 728, 729, 730, 731, 732, 733, 734, 735, 736, 737, 738, 739, 740, 741, 742, 743, 744, 745, 746, 747, 748, 749, 750, 751, 752, 753, 754, 755, 756, 757, 758, 759, 760, 761, 762, 763, 764, 765, 766, 767, 768, 769, 770, 771, 772, 773, 774, 775, 776, 777, 778, 779, 780, 781, 782, 783, 784, 785, 786, 787, 788, 789, 790, 791, 792, 793, 794, 795, 796, 797, 798, 799, 800, 801, 802, 803, 804, 805, 806, 807, 808, 809, 810, 811, 812, 813, 814, 815, 816, 817, 818, 819, 820, 821, 822, 823, 824, 825, 826, 827, 828, 829, 830, 831, 832, 833, 834, 835, 836, 837, 838, 839, 840, 841, 842, 843, 844, 845, 846, 847, 848, 849, 850, 851, 852, 853, 854, 855, 856, 857, 858, 859, 860, 861, 862, 863, 864, 865, 866, 867, 868, 869, 870, 871, 872, 873, 874, 875, 876, 877, 878, 879, 880, 881, 882, 883, 884, 885, 886, 887, 888, 889, 890, 891, 892, 893, 894, 895, 896, 897, 898, 899, 900, 901, 902, 903, 904, 905, 906, 907, 908, 909, 910, 911, 912, 913, 914, 915, 916, 917, 918, 919, 920, 921, 922, 923, 924, 925, 926, 927, 928, 929, 930, 931, 932, 933, 934, 935, 936, 937, 938, 939, 940, 941, 942, 943, 944, 945, 946, 947, 948, 949, 950, 951, 952, 953, 954, 955, 956, 957, 958, 959, 960, 961, 962, 963, 964, 965, 966, 967, 968, 969, 970, 971, 972, 973, 974, 975, 976, 977, 978, 979, 980, 981, 982, 983, 984, 985, 986, 987, 988, 989, 990, 991, 992, 993, 994, 995, 996, 997, 998, 999, 1000

NOTE :

- ALL DIMENSIONS ARE IN mm.
- ALL ELEVATIONS ARE VIEWED FROM OUTSIDE.
- ALL DIMENSIONS TO BE VERIFIED ON SITE BEFORE FABRICATION.

LEGEND :

(X1) --- DETAIL MARK NO.
 (X001) --- REFER SHEET NO.

- F.F.L. --- FINISHED FLOOR LEVEL
- S.F.L. --- STRUCTURAL FLOOR LEVEL
- (R) --- REVERSED DETAIL
- (A) --- FIXING LOCATION
- (L) --- FIXING LUG LOCATION

6. GLASS LEGEND

GL01 -- 8mm+12mm AIR GAP+10mm THK. I.G.U.
 GL01a -- 8mm+9mm AIR GAP+10mm THK. I.G.U.
 GL03 -- 6mm+12mm AIR GAP+6mm THK. I.G.U.
 GL04 -- 10mm THK. TEMPERED GLASS (PROTECTIVE BARRIER)
 GL05 -- 6mm+12mm AIR GAP+8mm THK. I.G.U.

C	22/03/2021	REVISION SUBJECT TO ARCH.COMMENT	Ivan
B	06/01/2021	REVISION SUBJECT TO ARCH.COMMENT	Ivan
A	07/11/2020	REVISION SUBJECT TO ARCH.COMMENT	Ivan
NO.	DATE	REVISED	BY

JOB NO. : J-852

PROJECT :
 PROPOSED RESIDENTIAL DEVELOPMENT
 AT 139 - 147 ARGYLE STREET,
 NKIL 6005, 6035 R.P., 6036 R.P.,
 6037 R.P. & 6038 R.P.

TITLE :
 SCHEDULE FOR Plenum Box
 AT TOWER 2 (1-21F)

DATE : 05-Dec-19 SCALE : 1:40

DRAWN BY : MN CHECKED BY : DW

美特鋁質有限公司
MIDI ALUMINIUM FABRICATOR LTD.
 Units 6-8, Sunray Industrial Centre, 1/F
 610 Cha Kwo Ling Road, Kowloon
 Tel:23489211-4 Fax:(852)2727666

DWG NO. : J852-SD-PB-4202 REV. : C

ELEVATION

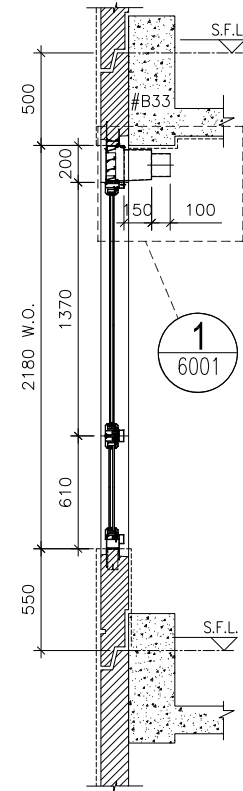
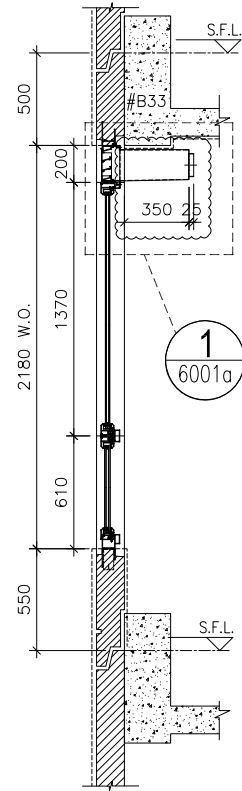
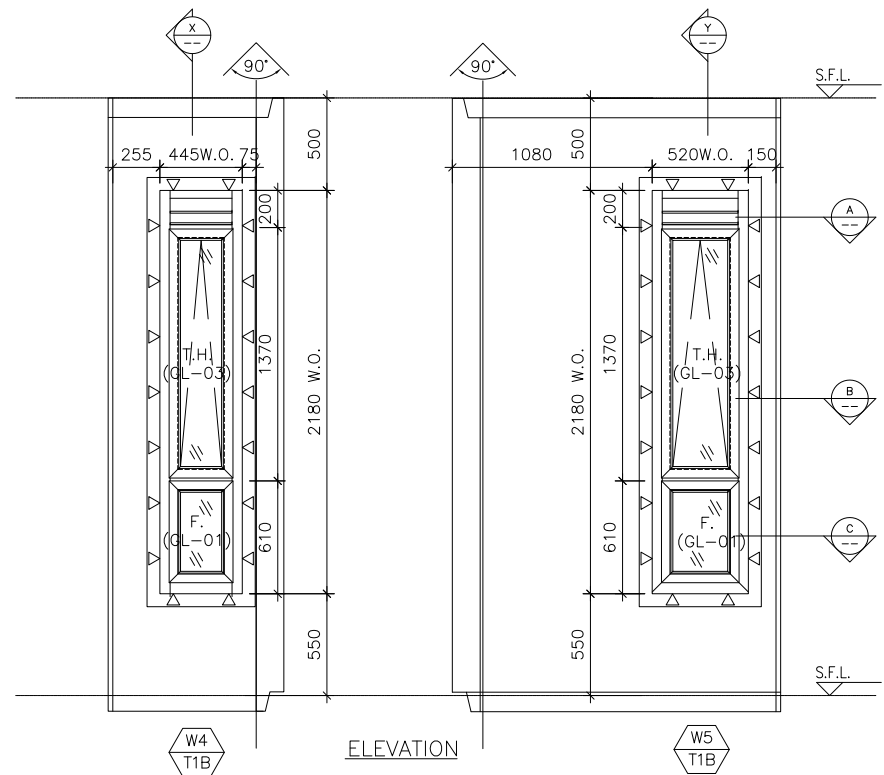

SECTION "X-X"

SECTION "Y-Y"

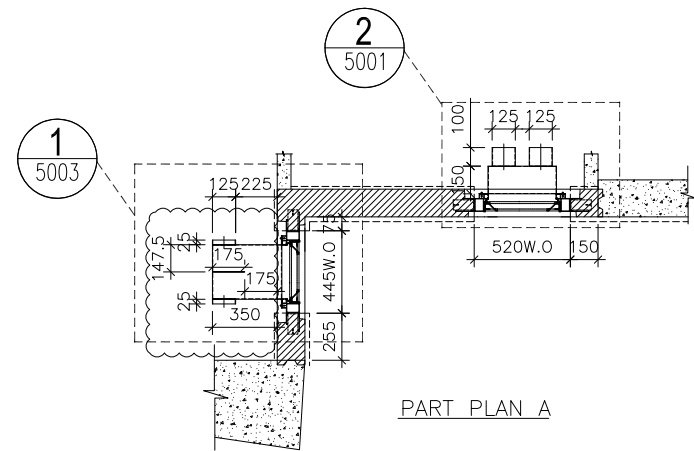

PART PLAN A

WINDOW MARK W4 / W5
T2A / T2A

LOCATION 2/F-21/F M.B. & EN.B. AT TOWER 2 FLAT A

SECTION 70mm ALUM. SECTION

GLAZING GL-01, GL-03

QUANTITY 17 / 17

REMARKS FACADE (PF-35)

B.D. REF :

CLIENT :

ARCHITECT :
AGC DESIGN LTD
101, 102, 103, 104, 105, 106, 107, 108, 109, 110, 111, 112, 113, 114, 115, 116, 117, 118, 119, 120, 121, 122, 123, 124, 125, 126, 127, 128, 129, 130, 131, 132, 133, 134, 135, 136, 137, 138, 139, 140, 141, 142, 143, 144, 145, 146, 147, 148, 149, 150, 151, 152, 153, 154, 155, 156, 157, 158, 159, 160, 161, 162, 163, 164, 165, 166, 167, 168, 169, 170, 171, 172, 173, 174, 175, 176, 177, 178, 179, 180, 181, 182, 183, 184, 185, 186, 187, 188, 189, 190, 191, 192, 193, 194, 195, 196, 197, 198, 199, 200, 201, 202, 203, 204, 205, 206, 207, 208, 209, 210, 211, 212, 213, 214, 215, 216, 217, 218, 219, 220, 221, 222, 223, 224, 225, 226, 227, 228, 229, 230, 231, 232, 233, 234, 235, 236, 237, 238, 239, 240, 241, 242, 243, 244, 245, 246, 247, 248, 249, 250, 251, 252, 253, 254, 255, 256, 257, 258, 259, 260, 261, 262, 263, 264, 265, 266, 267, 268, 269, 270, 271, 272, 273, 274, 275, 276, 277, 278, 279, 280, 281, 282, 283, 284, 285, 286, 287, 288, 289, 290, 291, 292, 293, 294, 295, 296, 297, 298, 299, 300, 301, 302, 303, 304, 305, 306, 307, 308, 309, 310, 311, 312, 313, 314, 315, 316, 317, 318, 319, 320, 321, 322, 323, 324, 325, 326, 327, 328, 329, 330, 331, 332, 333, 334, 335, 336, 337, 338, 339, 340, 341, 342, 343, 344, 345, 346, 347, 348, 349, 350, 351, 352, 353, 354, 355, 356, 357, 358, 359, 360, 361, 362, 363, 364, 365, 366, 367, 368, 369, 370, 371, 372, 373, 374, 375, 376, 377, 378, 379, 380, 381, 382, 383, 384, 385, 386, 387, 388, 389, 390, 391, 392, 393, 394, 395, 396, 397, 398, 399, 400, 401, 402, 403, 404, 405, 406, 407, 408, 409, 410, 411, 412, 413, 414, 415, 416, 417, 418, 419, 420, 421, 422, 423, 424, 425, 426, 427, 428, 429, 430, 431, 432, 433, 434, 435, 436, 437, 438, 439, 440, 441, 442, 443, 444, 445, 446, 447, 448, 449, 450, 451, 452, 453, 454, 455, 456, 457, 458, 459, 460, 461, 462, 463, 464, 465, 466, 467, 468, 469, 470, 471, 472, 473, 474, 475, 476, 477, 478, 479, 480, 481, 482, 483, 484, 485, 486, 487, 488, 489, 490, 491, 492, 493, 494, 495, 496, 497, 498, 499, 500, 501, 502, 503, 504, 505, 506, 507, 508, 509, 510, 511, 512, 513, 514, 515, 516, 517, 518, 519, 520, 521, 522, 523, 524, 525, 526, 527, 528, 529, 530, 531, 532, 533, 534, 535, 536, 537, 538, 539, 540, 541, 542, 543, 544, 545, 546, 547, 548, 549, 550, 551, 552, 553, 554, 555, 556, 557, 558, 559, 560, 561, 562, 563, 564, 565, 566, 567, 568, 569, 570, 571, 572, 573, 574, 575, 576, 577, 578, 579, 580, 581, 582, 583, 584, 585, 586, 587, 588, 589, 590, 591, 592, 593, 594, 595, 596, 597, 598, 599, 600, 601, 602, 603, 604, 605, 606, 607, 608, 609, 610, 611, 612, 613, 614, 615, 616, 617, 618, 619, 620, 621, 622, 623, 624, 625, 626, 627, 628, 629, 630, 631, 632, 633, 634, 635, 636, 637, 638, 639, 640, 641, 642, 643, 644, 645, 646, 647, 648, 649, 650, 651, 652, 653, 654, 655, 656, 657, 658, 659, 660, 661, 662, 663, 664, 665, 666, 667, 668, 669, 670, 671, 672, 673, 674, 675, 676, 677, 678, 679, 680, 681, 682, 683, 684, 685, 686, 687, 688, 689, 690, 691, 692, 693, 694, 695, 696, 697, 698, 699, 700, 701, 702, 703, 704, 705, 706, 707, 708, 709, 710, 711, 712, 713, 714, 715, 716, 717, 718, 719, 720, 721, 722, 723, 724, 725, 726, 727, 728, 729, 730, 731, 732, 733, 734, 735, 736, 737, 738, 739, 740, 741, 742, 743, 744, 745, 746, 747, 748, 749, 750, 751, 752, 753, 754, 755, 756, 757, 758, 759, 760, 761, 762, 763, 764, 765, 766, 767, 768, 769, 770, 771, 772, 773, 774, 775, 776, 777, 778, 779, 780, 781, 782, 783, 784, 785, 786, 787, 788, 789, 790, 791, 792, 793, 794, 795, 796, 797, 798, 799, 800, 801, 802, 803, 804, 805, 806, 807, 808, 809, 810, 811, 812, 813, 814, 815, 816, 817, 818, 819, 820, 821, 822, 823, 824, 825, 826, 827, 828, 829, 830, 831, 832, 833, 834, 835, 836, 837, 838, 839, 840, 841, 842, 843, 844, 845, 846, 847, 848, 849, 850, 851, 852, 853, 854, 855, 856, 857, 858, 859, 860, 861, 862, 863, 864, 865, 866, 867, 868, 869, 870, 871, 872, 873, 874, 875, 876, 877, 878, 879, 880, 881, 882, 883, 884, 885, 886, 887, 888, 889, 890, 891, 892, 893, 894, 895, 896, 897, 898, 899, 900, 901, 902, 903, 904, 905, 906, 907, 908, 909, 910, 911, 912, 913, 914, 915, 916, 917, 918, 919, 920, 921, 922, 923, 924, 925, 926, 927, 928, 929, 930, 931, 932, 933, 934, 935, 936, 937, 938, 939, 940, 941, 942, 943, 944, 945, 946, 947, 948, 949, 950, 951, 952, 953, 954, 955, 956, 957, 958, 959, 960, 961, 962, 963, 964, 965, 966, 967, 968, 969, 970, 971, 972, 973, 974, 975, 976, 977, 978, 979, 980, 981, 982, 983, 984, 985, 986, 987, 988, 989, 990, 991, 992, 993, 994, 995, 996, 997, 998, 999, 1000

MAIN CONTRACTOR :
Gammon

STRUCTURAL ENGINEER :
ARUP

FACADE CONSULTANT:
MEINHARDT

NOTE :
1. ALL DIMENSIONS ARE IN mm.
2. ALL ELEVATIONS ARE VIEWED FROM OUTSIDE.
3. ALL DIMENSIONS TO BE VERIFIED ON SITE BEFORE FABRICATION.

LEGEND :
x1 --- DETAIL MARK NO.
x001 --- REFER SHEET NO.
1. F.F.L. --- FINISHED FLOOR LEVEL
2. S.F.L. --- STRUCTURAL FLOOR LEVEL
3. (R) --- REVERSED DETAIL
4. ▲ --- FIXING LOCATION
5. △ --- FIXING LUG LOCATION
6. GLASS LEGEND
GL01 --- 8mm+12mm AIR GAP+10mm THK. I.G.U.
GL01a --- 8mm+9mm AIR GAP+10mm THK. I.G.U.
GL03 --- 6mm+12mm AIR GAP+6mm THK. I.G.U.
GL04 --- 10mm THK. TEMPERED GLASS (PROTECTIVE BARRIER)
GL05 --- 6mm+12mm AIR GAP+8mm THK. I.G.U.

C	22/03/2021	REVISION SUBJECT TO ARCH.COMMENT	Ivan
B	06/01/2021	REVISION SUBJECT TO ARCH.COMMENT	Ivan
A	07/11/2020	REVISION SUBJECT TO ARCH.COMMENT	Ivan
NO.	DATE	REVISED	BY

JOB NO. : J-852
PROJECT : PROPOSED RESIDENTIAL DEVELOPMENT AT 139 - 147 ARGYLE STREET, NKIL 6005, 6035 R.P., 6036 R.P., 6037 R.P. & 6038 R.P.

TITLE : SCHEDULE FOR Plenum Box AT TOWER 2 (1-21F)

DATE : 05-Dec-19 SCALE : 1:40
DRAWN BY : MN CHECKED BY : DW

美特鋁質有限公司
MIDI ALUMINIUM FABRICATOR LTD.
Units 6-8, Sunray Industrial Centre, 1/F
610 Cha Kwo Ling Road, Kowloon
Tel:23489211-4 Fax:(852)2727666

DWG NO. : J852-SD-PB-4202A REV. : C

ELEVATION

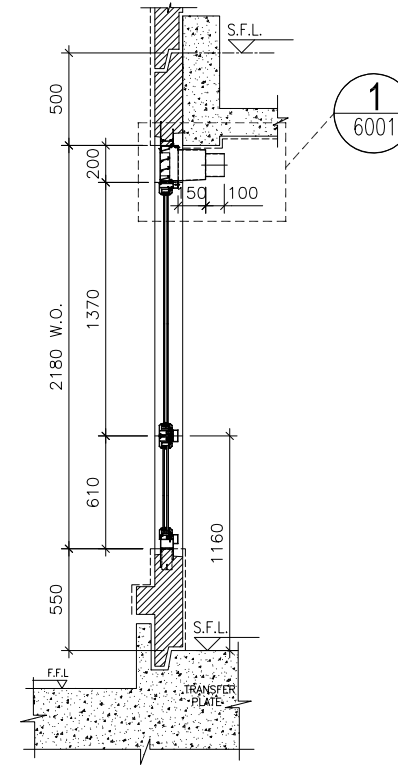
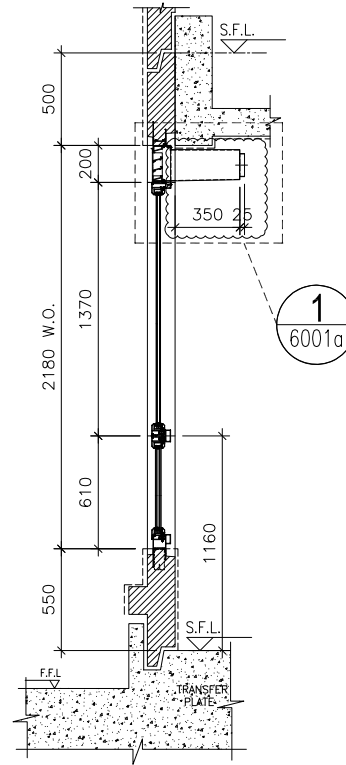
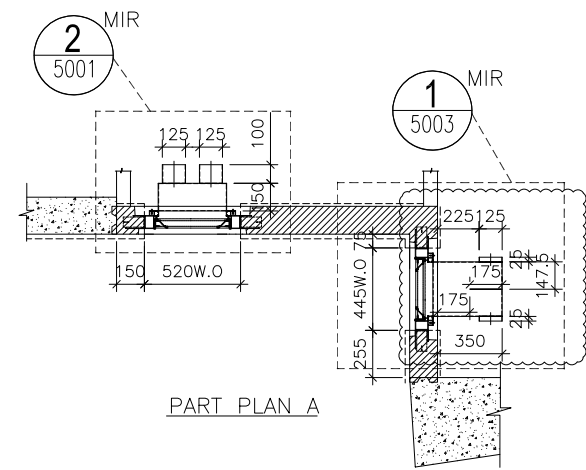
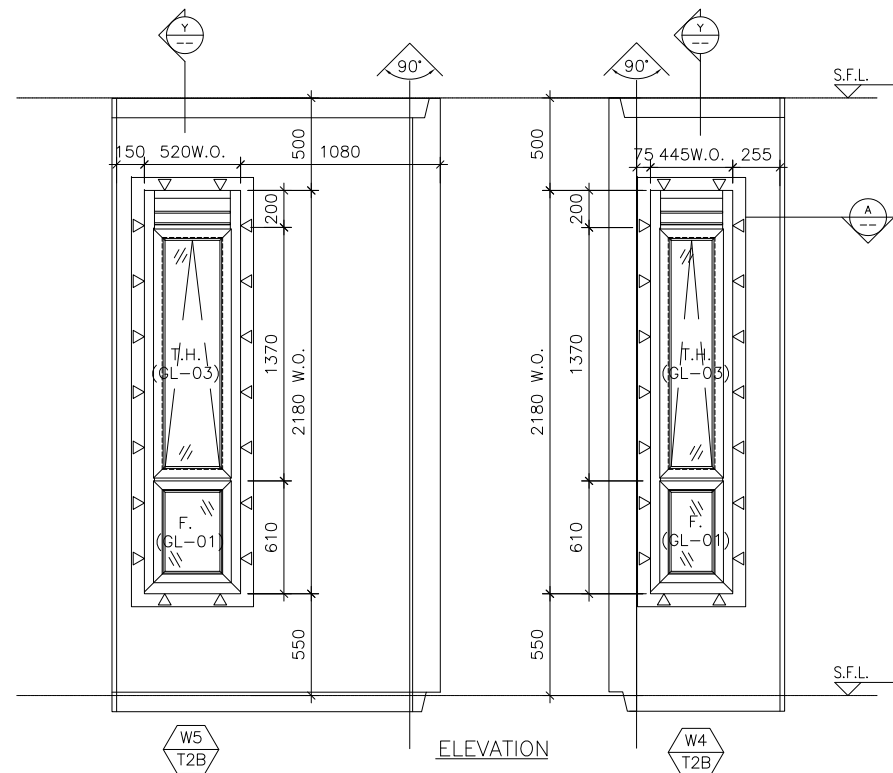

SECTION "Y-Y"

SECTION "X-X"

WINDOW MARK W5
T2B / W4
T2B

LOCATION 1/F M.B. & EN.B. AT TOWER 2 FLAT B

SECTION 70mm ALUM. SECTION

GLAZING GL-01, GL-03

QUANTITY 1 / 1

REMARKS FACADE (PF-36)

B.D. REF :

CLIENT :

ARCHITECT :
AGC DESIGN LTD
AGC DESIGN LTD
101, 102, 103, 104, 105, 106, 107, 108, 109, 110, 111, 112, 113, 114, 115, 116, 117, 118, 119, 120, 121, 122, 123, 124, 125, 126, 127, 128, 129, 130, 131, 132, 133, 134, 135, 136, 137, 138, 139, 140, 141, 142, 143, 144, 145, 146, 147, 148, 149, 150, 151, 152, 153, 154, 155, 156, 157, 158, 159, 160, 161, 162, 163, 164, 165, 166, 167, 168, 169, 170, 171, 172, 173, 174, 175, 176, 177, 178, 179, 180, 181, 182, 183, 184, 185, 186, 187, 188, 189, 190, 191, 192, 193, 194, 195, 196, 197, 198, 199, 200, 201, 202, 203, 204, 205, 206, 207, 208, 209, 210, 211, 212, 213, 214, 215, 216, 217, 218, 219, 220, 221, 222, 223, 224, 225, 226, 227, 228, 229, 230, 231, 232, 233, 234, 235, 236, 237, 238, 239, 240, 241, 242, 243, 244, 245, 246, 247, 248, 249, 250, 251, 252, 253, 254, 255, 256, 257, 258, 259, 260, 261, 262, 263, 264, 265, 266, 267, 268, 269, 270, 271, 272, 273, 274, 275, 276, 277, 278, 279, 280, 281, 282, 283, 284, 285, 286, 287, 288, 289, 290, 291, 292, 293, 294, 295, 296, 297, 298, 299, 300, 301, 302, 303, 304, 305, 306, 307, 308, 309, 310, 311, 312, 313, 314, 315, 316, 317, 318, 319, 320, 321, 322, 323, 324, 325, 326, 327, 328, 329, 330, 331, 332, 333, 334, 335, 336, 337, 338, 339, 340, 341, 342, 343, 344, 345, 346, 347, 348, 349, 350, 351, 352, 353, 354, 355, 356, 357, 358, 359, 360, 361, 362, 363, 364, 365, 366, 367, 368, 369, 370, 371, 372, 373, 374, 375, 376, 377, 378, 379, 380, 381, 382, 383, 384, 385, 386, 387, 388, 389, 390, 391, 392, 393, 394, 395, 396, 397, 398, 399, 400, 401, 402, 403, 404, 405, 406, 407, 408, 409, 410, 411, 412, 413, 414, 415, 416, 417, 418, 419, 420, 421, 422, 423, 424, 425, 426, 427, 428, 429, 430, 431, 432, 433, 434, 435, 436, 437, 438, 439, 440, 441, 442, 443, 444, 445, 446, 447, 448, 449, 450, 451, 452, 453, 454, 455, 456, 457, 458, 459, 460, 461, 462, 463, 464, 465, 466, 467, 468, 469, 470, 471, 472, 473, 474, 475, 476, 477, 478, 479, 480, 481, 482, 483, 484, 485, 486, 487, 488, 489, 490, 491, 492, 493, 494, 495, 496, 497, 498, 499, 500, 501, 502, 503, 504, 505, 506, 507, 508, 509, 510, 511, 512, 513, 514, 515, 516, 517, 518, 519, 520, 521, 522, 523, 524, 525, 526, 527, 528, 529, 530, 531, 532, 533, 534, 535, 536, 537, 538, 539, 540, 541, 542, 543, 544, 545, 546, 547, 548, 549, 550, 551, 552, 553, 554, 555, 556, 557, 558, 559, 560, 561, 562, 563, 564, 565, 566, 567, 568, 569, 570, 571, 572, 573, 574, 575, 576, 577, 578, 579, 580, 581, 582, 583, 584, 585, 586, 587, 588, 589, 590, 591, 592, 593, 594, 595, 596, 597, 598, 599, 600, 601, 602, 603, 604, 605, 606, 607, 608, 609, 610, 611, 612, 613, 614, 615, 616, 617, 618, 619, 620, 621, 622, 623, 624, 625, 626, 627, 628, 629, 630, 631, 632, 633, 634, 635, 636, 637, 638, 639, 640, 641, 642, 643, 644, 645, 646, 647, 648, 649, 650, 651, 652, 653, 654, 655, 656, 657, 658, 659, 660, 661, 662, 663, 664, 665, 666, 667, 668, 669, 670, 671, 672, 673, 674, 675, 676, 677, 678, 679, 680, 681, 682, 683, 684, 685, 686, 687, 688, 689, 690, 691, 692, 693, 694, 695, 696, 697, 698, 699, 700, 701, 702, 703, 704, 705, 706, 707, 708, 709, 710, 711, 712, 713, 714, 715, 716, 717, 718, 719, 720, 721, 722, 723, 724, 725, 726, 727, 728, 729, 730, 731, 732, 733, 734, 735, 736, 737, 738, 739, 740, 741, 742, 743, 744, 745, 746, 747, 748, 749, 750, 751, 752, 753, 754, 755, 756, 757, 758, 759, 760, 761, 762, 763, 764, 765, 766, 767, 768, 769, 770, 771, 772, 773, 774, 775, 776, 777, 778, 779, 780, 781, 782, 783, 784, 785, 786, 787, 788, 789, 790, 791, 792, 793, 794, 795, 796, 797, 798, 799, 800, 801, 802, 803, 804, 805, 806, 807, 808, 809, 810, 811, 812, 813, 814, 815, 816, 817, 818, 819, 820, 821, 822, 823, 824, 825, 826, 827, 828, 829, 830, 831, 832, 833, 834, 835, 836, 837, 838, 839, 840, 841, 842, 843, 844, 845, 846, 847, 848, 849, 850, 851, 852, 853, 854, 855, 856, 857, 858, 859, 860, 861, 862, 863, 864, 865, 866, 867, 868, 869, 870, 871, 872, 873, 874, 875, 876, 877, 878, 879, 880, 881, 882, 883, 884, 885, 886, 887, 888, 889, 890, 891, 892, 893, 894, 895, 896, 897, 898, 899, 900, 901, 902, 903, 904, 905, 906, 907, 908, 909, 910, 911, 912, 913, 914, 915, 916, 917, 918, 919, 920, 921, 922, 923, 924, 925, 926, 927, 928, 929, 930, 931, 932, 933, 934, 935, 936, 937, 938, 939, 940, 941, 942, 943, 944, 945, 946, 947, 948, 949, 950, 951, 952, 953, 954, 955, 956, 957, 958, 959, 960, 961, 962, 963, 964, 965, 966, 967, 968, 969, 970, 971, 972, 973, 974, 975, 976, 977, 978, 979, 980, 981, 982, 983, 984, 985, 986, 987, 988, 989, 990, 991, 992, 993, 994, 995, 996, 997, 998, 999, 1000

MAIN CONTRACTOR :
Gammon

STRUCTURAL ENGINEER :
ARUP

FACADE CONSULTANT:
MEINHARDT

NOTE :
1. ALL DIMENSIONS ARE IN mm.
2. ALL ELEVATIONS ARE VIEWED FROM OUTSIDE.
3. ALL DIMENSIONS TO BE VERIFIED ON SITE BEFORE FABRICATION.

LEGEND :
x1 — DETAIL MARK NO.
x001 — REFER SHEET NO.

1. F.F.L. -- FINISHED FLOOR LEVEL
2. S.F.L. -- STRUCTURAL FLOOR LEVEL
3. (R) -- REVERSED DETAIL

C	22/03/2021	REVISION SUBJECT TO ARCH.COMMENT	Ivan
B	06/01/2021	REVISION SUBJECT TO ARCH.COMMENT	Ivan
A	07/11/2020	REVISION SUBJECT TO ARCH.COMMENT	Ivan
NO.	DATE	REVISION	BY

JOB NO. : J-852
PROJECT : PROPOSED RESIDENTIAL DEVELOPMENT AT 139 - 147 ARGYLE STREET, NKIL 6005, 6035 R.P., 6036 R.P., 6037 R.P. & 6038 R.P.
TITLE : SCHEDULE FOR Plenum Box AT TOWER 2 (1-21F)

DATE : 05-Dec-19 SCALE : 1:40
DRAWN BY : MN CHECKED BY : DW

美特鋁質有限公司
MIDI ALUMINIUM FABRICATOR LTD.
Units 6-8, Sunray Industrial Centre, 1/F
610 Cha Kwo Ling Road, Kowloon
Tel:23489211-4 Fax:(852)2727666

DWG NO. : J852-SD-PB-4203 REV. : C

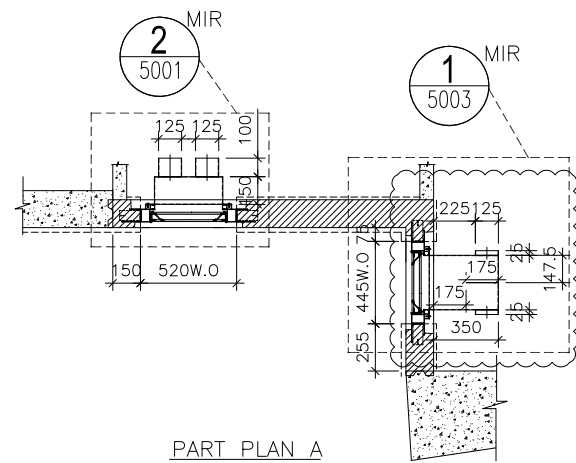
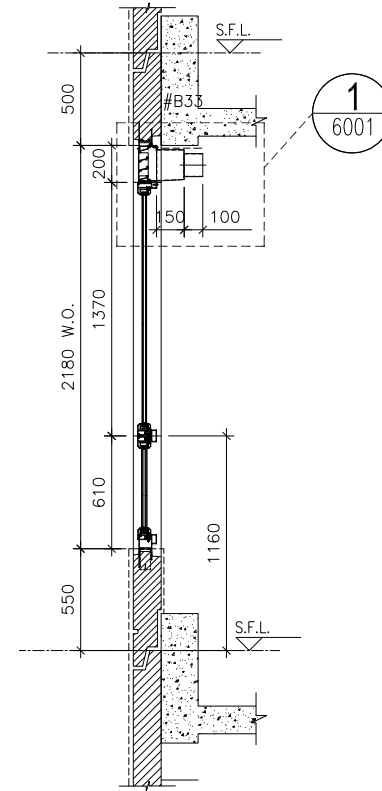
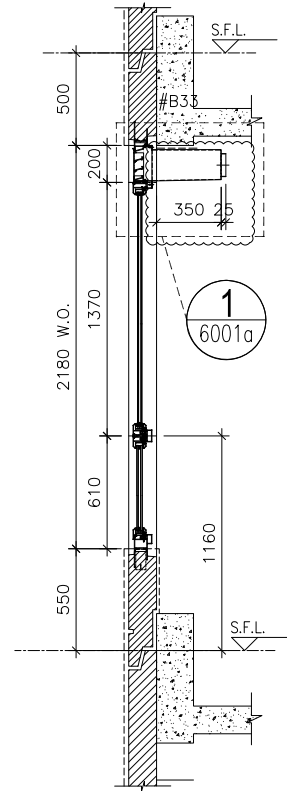
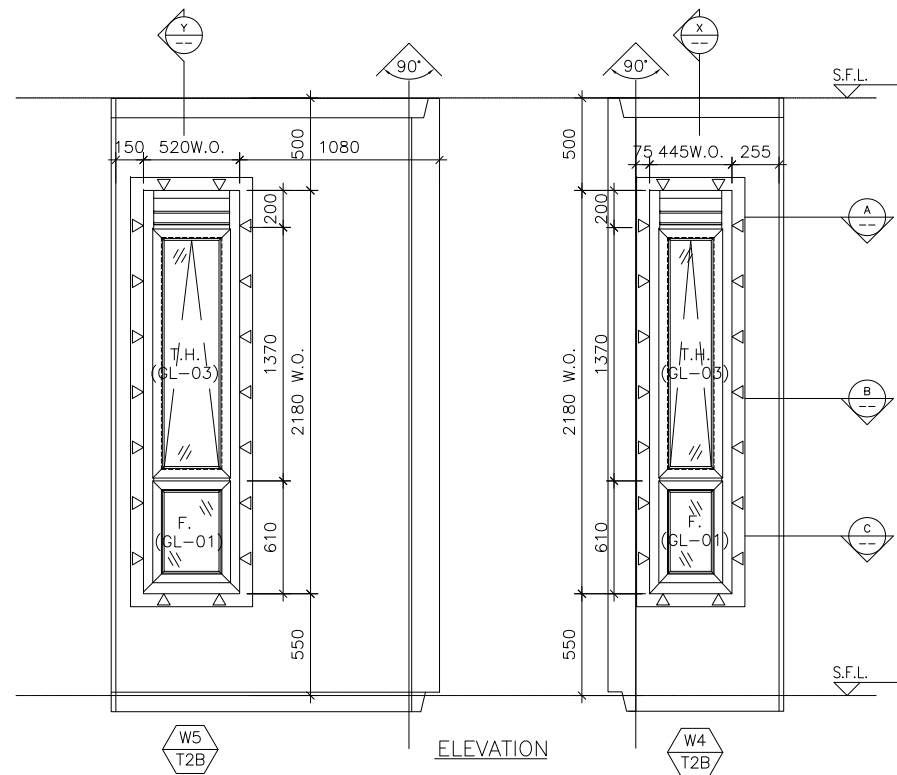

ELEVATION

SECTION "X-X"

SECTION "Y-Y"

PART PLAN A

B.D. REF :

CLIENT :

ARCHITECT :
AGC DESIGN LTD
 100, 101, 102, 103, 104, 105, 106, 107, 108, 109, 110, 111, 112, 113, 114, 115, 116, 117, 118, 119, 120, 121, 122, 123, 124, 125, 126, 127, 128, 129, 130, 131, 132, 133, 134, 135, 136, 137, 138, 139, 140, 141, 142, 143, 144, 145, 146, 147, 148, 149, 150, 151, 152, 153, 154, 155, 156, 157, 158, 159, 160, 161, 162, 163, 164, 165, 166, 167, 168, 169, 170, 171, 172, 173, 174, 175, 176, 177, 178, 179, 180, 181, 182, 183, 184, 185, 186, 187, 188, 189, 190, 191, 192, 193, 194, 195, 196, 197, 198, 199, 200, 201, 202, 203, 204, 205, 206, 207, 208, 209, 210, 211, 212, 213, 214, 215, 216, 217, 218, 219, 220, 221, 222, 223, 224, 225, 226, 227, 228, 229, 230, 231, 232, 233, 234, 235, 236, 237, 238, 239, 240, 241, 242, 243, 244, 245, 246, 247, 248, 249, 250, 251, 252, 253, 254, 255, 256, 257, 258, 259, 260, 261, 262, 263, 264, 265, 266, 267, 268, 269, 270, 271, 272, 273, 274, 275, 276, 277, 278, 279, 280, 281, 282, 283, 284, 285, 286, 287, 288, 289, 290, 291, 292, 293, 294, 295, 296, 297, 298, 299, 300, 301, 302, 303, 304, 305, 306, 307, 308, 309, 310, 311, 312, 313, 314, 315, 316, 317, 318, 319, 320, 321, 322, 323, 324, 325, 326, 327, 328, 329, 330, 331, 332, 333, 334, 335, 336, 337, 338, 339, 340, 341, 342, 343, 344, 345, 346, 347, 348, 349, 350, 351, 352, 353, 354, 355, 356, 357, 358, 359, 360, 361, 362, 363, 364, 365, 366, 367, 368, 369, 370, 371, 372, 373, 374, 375, 376, 377, 378, 379, 380, 381, 382, 383, 384, 385, 386, 387, 388, 389, 390, 391, 392, 393, 394, 395, 396, 397, 398, 399, 400, 401, 402, 403, 404, 405, 406, 407, 408, 409, 410, 411, 412, 413, 414, 415, 416, 417, 418, 419, 420, 421, 422, 423, 424, 425, 426, 427, 428, 429, 430, 431, 432, 433, 434, 435, 436, 437, 438, 439, 440, 441, 442, 443, 444, 445, 446, 447, 448, 449, 450, 451, 452, 453, 454, 455, 456, 457, 458, 459, 460, 461, 462, 463, 464, 465, 466, 467, 468, 469, 470, 471, 472, 473, 474, 475, 476, 477, 478, 479, 480, 481, 482, 483, 484, 485, 486, 487, 488, 489, 490, 491, 492, 493, 494, 495, 496, 497, 498, 499, 500, 501, 502, 503, 504, 505, 506, 507, 508, 509, 510, 511, 512, 513, 514, 515, 516, 517, 518, 519, 520, 521, 522, 523, 524, 525, 526, 527, 528, 529, 530, 531, 532, 533, 534, 535, 536, 537, 538, 539, 540, 541, 542, 543, 544, 545, 546, 547, 548, 549, 550, 551, 552, 553, 554, 555, 556, 557, 558, 559, 560, 561, 562, 563, 564, 565, 566, 567, 568, 569, 570, 571, 572, 573, 574, 575, 576, 577, 578, 579, 580, 581, 582, 583, 584, 585, 586, 587, 588, 589, 590, 591, 592, 593, 594, 595, 596, 597, 598, 599, 600, 601, 602, 603, 604, 605, 606, 607, 608, 609, 610, 611, 612, 613, 614, 615, 616, 617, 618, 619, 620, 621, 622, 623, 624, 625, 626, 627, 628, 629, 630, 631, 632, 633, 634, 635, 636, 637, 638, 639, 640, 641, 642, 643, 644, 645, 646, 647, 648, 649, 650, 651, 652, 653, 654, 655, 656, 657, 658, 659, 660, 661, 662, 663, 664, 665, 666, 667, 668, 669, 670, 671, 672, 673, 674, 675, 676, 677, 678, 679, 680, 681, 682, 683, 684, 685, 686, 687, 688, 689, 690, 691, 692, 693, 694, 695, 696, 697, 698, 699, 700, 701, 702, 703, 704, 705, 706, 707, 708, 709, 710, 711, 712, 713, 714, 715, 716, 717, 718, 719, 720, 721, 722, 723, 724, 725, 726, 727, 728, 729, 730, 731, 732, 733, 734, 735, 736, 737, 738, 739, 740, 741, 742, 743, 744, 745, 746, 747, 748, 749, 750, 751, 752, 753, 754, 755, 756, 757, 758, 759, 760, 761, 762, 763, 764, 765, 766, 767, 768, 769, 770, 771, 772, 773, 774, 775, 776, 777, 778, 779, 780, 781, 782, 783, 784, 785, 786, 787, 788, 789, 790, 791, 792, 793, 794, 795, 796, 797, 798, 799, 800, 801, 802, 803, 804, 805, 806, 807, 808, 809, 810, 811, 812, 813, 814, 815, 816, 817, 818, 819, 820, 821, 822, 823, 824, 825, 826, 827, 828, 829, 830, 831, 832, 833, 834, 835, 836, 837, 838, 839, 840, 841, 842, 843, 844, 845, 846, 847, 848, 849, 850, 851, 852, 853, 854, 855, 856, 857, 858, 859, 860, 861, 862, 863, 864, 865, 866, 867, 868, 869, 870, 871, 872, 873, 874, 875, 876, 877, 878, 879, 880, 881, 882, 883, 884, 885, 886, 887, 888, 889, 890, 891, 892, 893, 894, 895, 896, 897, 898, 899, 900, 901, 902, 903, 904, 905, 906, 907, 908, 909, 910, 911, 912, 913, 914, 915, 916, 917, 918, 919, 920, 921, 922, 923, 924, 925, 926, 927, 928, 929, 930, 931, 932, 933, 934, 935, 936, 937, 938, 939, 940, 941, 942, 943, 944, 945, 946, 947, 948, 949, 950, 951, 952, 953, 954, 955, 956, 957, 958, 959, 960, 961, 962, 963, 964, 965, 966, 967, 968, 969, 970, 971, 972, 973, 974, 975, 976, 977, 978, 979, 980, 981, 982, 983, 984, 985, 986, 987, 988, 989, 990, 991, 992, 993, 994, 995, 996, 997, 998, 999, 1000

MAIN CONTRACTOR :
Gammon

STRUCTURAL ENGINEER :
ARUP

FACADE CONSULTANT:
MEINHARDT

NOTE :
 1. ALL DIMENSIONS ARE IN mm.
 2. ALL ELEVATIONS ARE VIEWED FROM OUTSIDE.
 3. ALL DIMENSIONS TO BE VERIFIED ON SITE BEFORE FABRICATION.

LEGEND :
 (x1) — DETAIL MARK NO.
 (x001) — REFER SHEET NO.
 1. F.F.L. — FINISHED FLOOR LEVEL
 2. S.F.L. — STRUCTURAL FLOOR LEVEL
 3. (R) — REVERSED DETAIL

C	22/03/2021	REVISION SUBJECT TO ARCH.COMMENT	Ivan
B	06/01/2021	REVISION SUBJECT TO ARCH.COMMENT	Ivan
A	07/11/2020	REVISION SUBJECT TO ARCH.COMMENT	Ivan
NO.	DATE	REVISED	BY

JOB NO. : J-852
 PROJECT :
 PROPOSED RESIDENTIAL DEVELOPMENT
 AT 139 - 147 ARGYLE STREET,
 NKIL 6005, 6035 R.P., 6036 R.P.,
 6037 R.P. & 6038 R.P.

TITLE :
 SCHEDULE FOR Plenum Box
 AT TOWER 2 (1-21F)

DATE : 05-Dec-19 SCALE : 1:40

DRAWN BY : MN CHECKED BY : DW

美特鋁質有限公司
MIDI ALUMINIUM FABRICATOR LTD.
 Units 6-8, Sunray Industrial Centre, 1/F
 610 Cha Kwo Ling Road, Kowloon
 Tel:23489211-4 Fax:(852)2727666

DWG NO. : J852-SD-PB-4203A REV. : C

WINDOW MARK	W5 T2B / W4 T2B
LOCATION	2/F-21/F M.B. & EN.B. AT TOWER 2 FLAT B
SECTION	70mm ALUM. SECTION
GLAZING	GL-01, GL-03
QUANTITY	17 / 17
REMARKS	FACADE (PF-36)

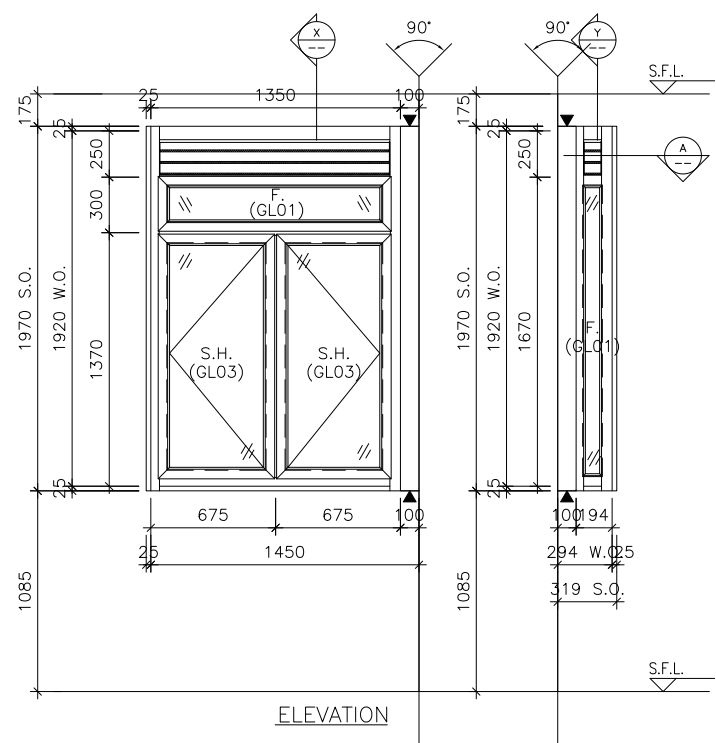

ELEVATION

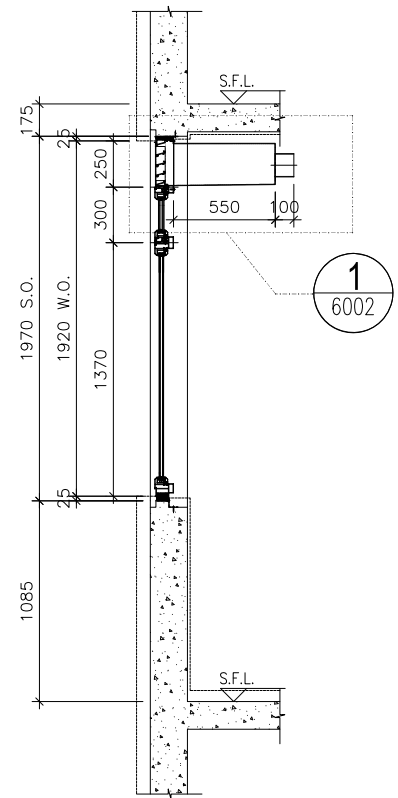

SECTION "X-X"

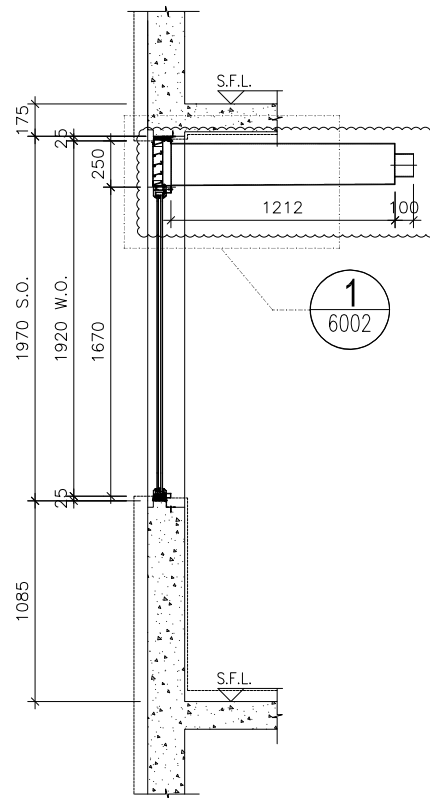

SECTION "Y-Y"

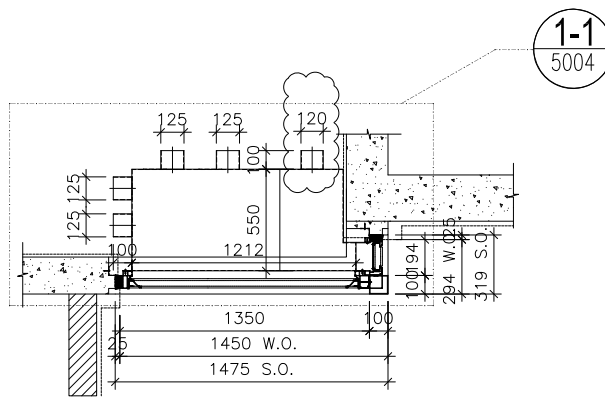

PART PLAN A

ELEVATION

WINDOW MARK	W8 T2A
LOCATION	1/F~21/F KIT. AT TOWER 2 FLAT A
SECTION	50mm ALUM. SECTION
GLAZING	GL01, GL03
QUANTITY	18
REMARKS	

B.D. REF :

CLIENT :

ARCHITECT :

AGC DESIGN LTD

MAIN CONTRACTOR :

Gammon

STRUCTURAL ENGINEER :

ARUP

FACADE CONSULTANT:

MEINHARDT

NOTE :

- ALL DIMENSIONS ARE IN mm.
- ALL ELEVATIONS ARE VIEWED FROM OUTSIDE.
- ALL DIMENSIONS TO BE VERIFIED ON SITE BEFORE FABRICATION.

LEGEND :

x1 --- DETAIL MARK NO.
x001 --- REFER SHEET NO.

- F.F.L. --- FINISHED FLOOR LEVEL
- S.F.L. --- STRUCTURAL FLOOR LEVEL
- ⊗ --- REVERSED DETAIL
- ▲ --- FIXING LOCATION
- △ --- FIXING LUG LOCATION
- GLASS LEGEND
 - GL01 --- 8mm+12mm AIR GAP+10mm THK. I.G.U.
 - GL01a --- 8mm+9mm AIR GAP+10mm THK. I.G.U.
 - GL03 --- 6mm+12mm AIR GAP+6mm THK. I.G.U.
 - GL04 --- 10mm THK. TEMPERED GLASS (PROTECTIVE BARRIER)
 - GL05 --- 6mm+12mm AIR GAP+8mm THK. I.G.U.

NO.	DATE	REVISION	BY
A	09/12/2020	REVISION SUBJECT TO ARCH.COMMENT	lvart

JOB NO. : J-852

PROJECT :

PROPOSED RESIDENTIAL DEVELOPMENT
AT 139 - 147 ARGYLE STREET,
NKIL 6005, 6035 R.P., 6036 R.P.,
6037 R.P. & 6038 R.P.

TITLE :

SCHEDULE FOR Plenum Box
AT TOWER 2 (1-21F)

DATE : 05-FEB-20 SCALE : 1:100

DRAWN BY : MN CHECKED BY : DW

美特鋁質有限公司
MIDI ALUMINIUM FABRICATOR LTD.
Units 6-8, Sunray Industrial Centre, 1/F
610 Cha Kwo Ling Road, Kowloon
Tel:23489211-4 Fax:(852)2727666

DWG NO. : J852-SD-PB-4204 REV. : A

ELEVATION

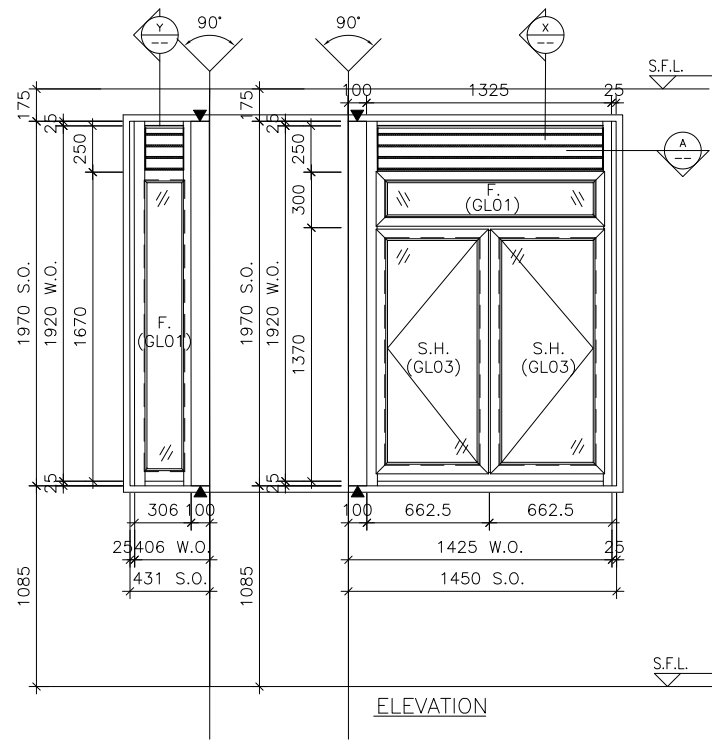

ELEVATION

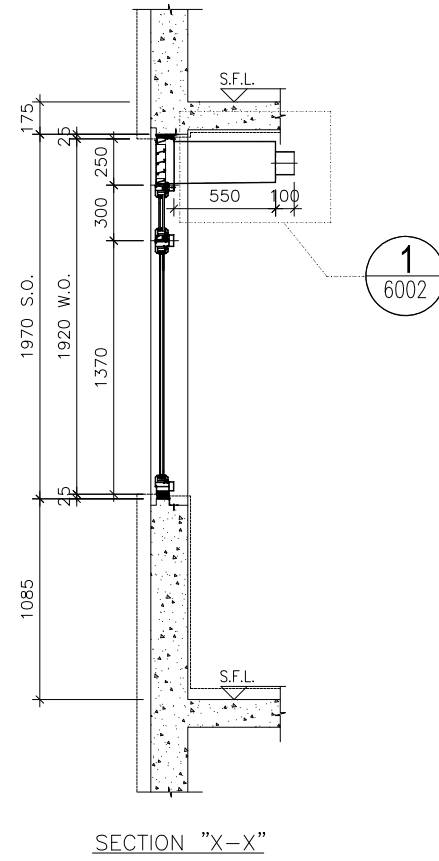

SECTION "X-X"

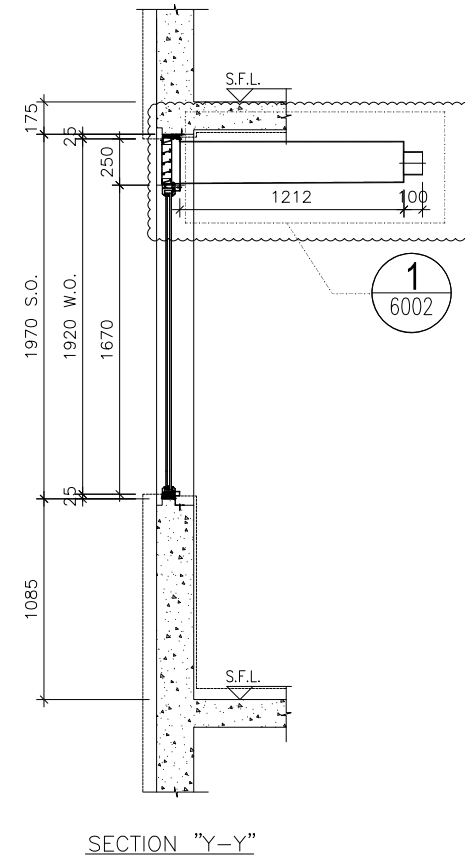

SECTION "Y-Y"

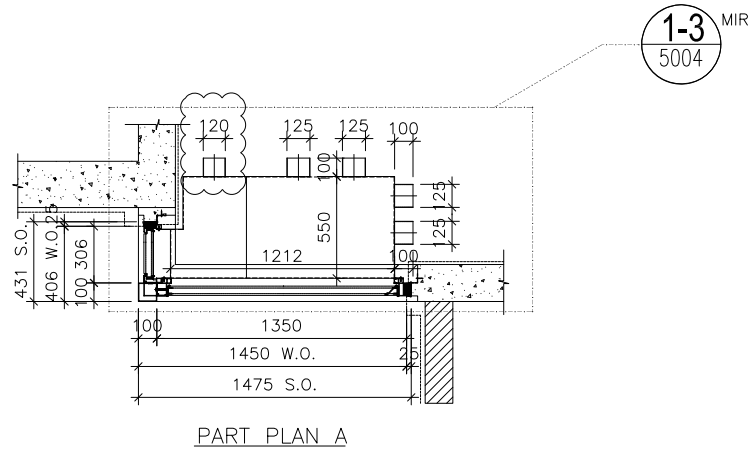

PART PLAN A

WINDOW MARK



LOCATION 1/F~21/F KIT. AT TOWER 2 FLAT B

SECTION 50mm ALUM. SECTION

GLAZING GL01, GL03

QUANTITY 18

REMARKS

B.D. REF :

CLIENT :

ARCHITECT :
AGC DESIGN LTD

MAIN CONTRACTOR :
Gammon

STRUCTURAL ENGINEER :
ARUP

FAÇADE CONSULTANT:
MEINHARDT

NOTE :
1. ALL DIMENSIONS ARE IN mm.
2. ALL ELEVATIONS ARE VIEWED FROM OUTSIDE.
3. ALL DIMENSIONS TO BE VERIFIED ON SITE BEFORE FABRICATION.

LEGEND :
x1 — DETAIL MARK NO.
x001 — REFER SHEET NO.
1. F.F.L. — FINISHED FLOOR LEVEL
2. S.F.L. — STRUCTURAL FLOOR LEVEL
3. (R) — REVERSED DETAIL
4. ▲ — FIXING LOCATION
5. △ — FIXING LUG LOCATION
6. GLASS LEGEND
GL01 — 8mm+12mm AIR GAP+10mm THK. I.G.U.
GL01a — 8mm+9mm AIR GAP+10mm THK. I.G.U.
GL03 — 6mm+12mm AIR GAP+6mm THK. I.G.U.
GL04 — 10mm THK. TEMPERED GLASS (PROTECTIVE BARRIER)
GL05 — 6mm+12mm AIR GAP+8mm THK. I.G.U.

NO.	DATE	REVISION	BY
A	09/12/2020	REVISION SUBJECT TO ARCH.COMMENT	lvart

JOB NO. : J-852
PROJECT : PROPOSED RESIDENTIAL DEVELOPMENT AT 139 - 147 ARGYLE STREET, NKIL 6005, 6035 R.P., 6036 R.P., 6037 R.P. & 6038 R.P.

TITLE : SCHEDULE FOR Plenum Box AT TOWER 2 (1-21F)

DATE : 05-FEB-20 SCALE : 1:100

DRAWN BY : MN CHECKED BY : DW

美特鋁質有限公司
MIDI ALUMINIUM FABRICATOR LTD.
Units 6-8, Sunray Industrial Centre, 1/F
610 Cha Kwo Ling Road, Kowloon
Tel:23489211-4 Fax:(852)27727666

DWG NO. : J852-SD-PB-4205 REV. : A

ELEVATION

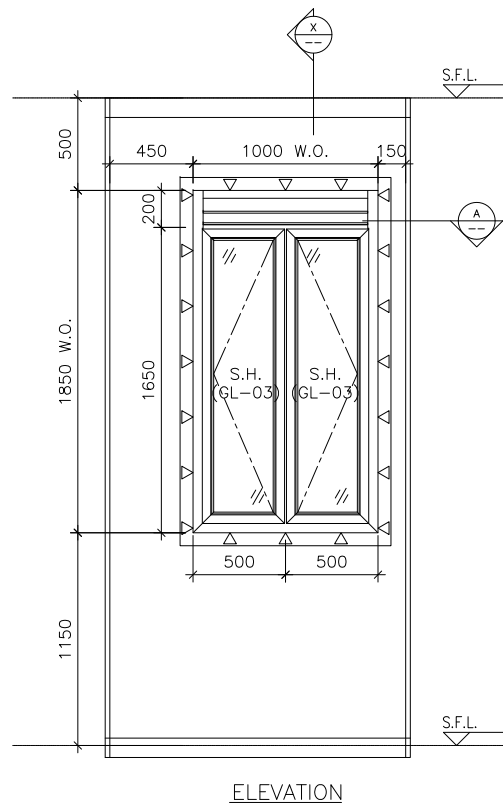

ELEVATION

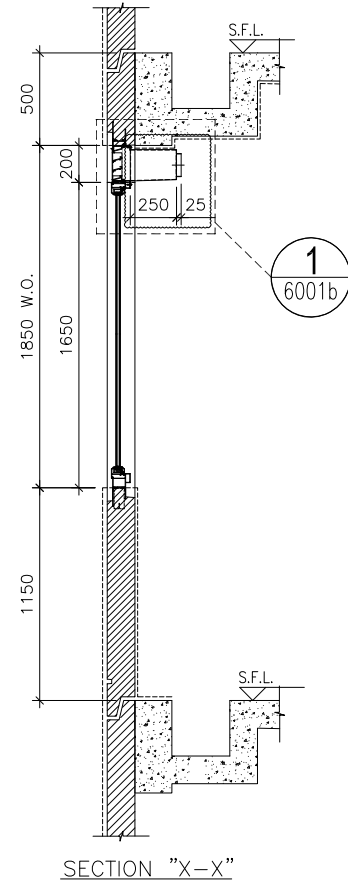

SECTION "X-X"

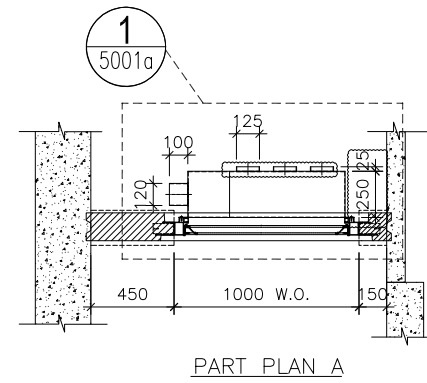

PART PLAN A

WINDOW MARK



LOCATION 22/F KIT. AT TOWER 2 FLAT C

SECTION 70mm ALUM. SECTION

GLAZING GL-03

QUANTITY 1

REMARKS FACADE (PF-28)

B.D. REF :

CLIENT :

ARCHITECT :

AGC
DESIGN LTD

MAIN CONTRACTOR :

Gammon

STRUCTURAL ENGINEER :

ARUP

FACADE CONSULTANT:

MEINHARDT

NOTE :

1. ALL DIMENSIONS ARE IN mm.
2. ALL ELEVATIONS ARE VIEWED FROM OUTSIDE.
3. ALL DIMENSIONS TO BE VERIFIED ON SITE BEFORE FABRICATION.

LEGEND :

- x1 --- DETAIL MARK NO.
- x001 --- REFER SHEET NO.

1. F.F.L. --- FINISHED FLOOR LEVEL
2. S.F.L. --- STRUCTURAL FLOOR LEVEL
3. (R) --- REVERSED DETAIL
4. ▲ --- FIXING LOCATION
5. △ --- FIXING LUG LOCATION

6. GLASS LEGEND

- GL01 -- 8mm+12mm AIR GAP+10mm THK. I.G.U.
- GL01a -- 8mm+9mm AIR GAP+10mm THK. I.G.U.
- GL03 -- 6mm+12mm AIR GAP+6mm THK. I.G.U.
- GL04 -- 10mm THK. TEMPERED GLASS (PROTECTIVE BARRIER)
- GL05 -- 6mm+12mm AIR GAP+8mm THK. I.G.U.

C	05/03/2021	REVISION SUBJECT TO ARCH.COMMENT	Ivan
B	06/01/2021	REVISION SUBJECT TO ARCH.COMMENT	Ivan
A	09/12/2020	REVISION SUBJECT TO ARCH.COMMENT	Ivan
NO.	DATE	REVISED	BY

JOB NO. : J-852

PROJECT :
PROPOSED RESIDENTIAL DEVELOPMENT
AT 139 - 147 ARGYLE STREET,
NKIL 6005, 6035 R.P., 6036 R.P.,
6037 R.P. & 6038 R.P.

TITLE :
SCHEDULE FOR Plenum Box
AT TOWER 2 (22F)

DATE : 05-Dec-19

SCALE : 1:40

DRAWN BY : MN

CHECKED BY : DW

美特鋁質有限公司
MIDI ALUMINIUM FABRICATOR LTD.
Units 6-8, Sunray Industrial Centre, 1/F
610 Cha Kwo Ling Road, Kowloon
Tel:23489211-4 Fax:(852)2727666

DWG NO. : J852-SD-PB-4206

REV. : C

ELEVATION

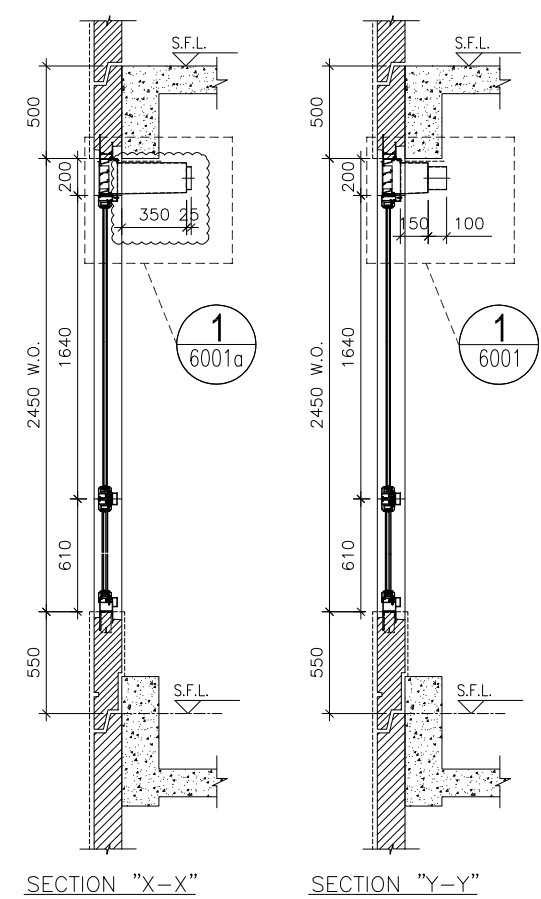
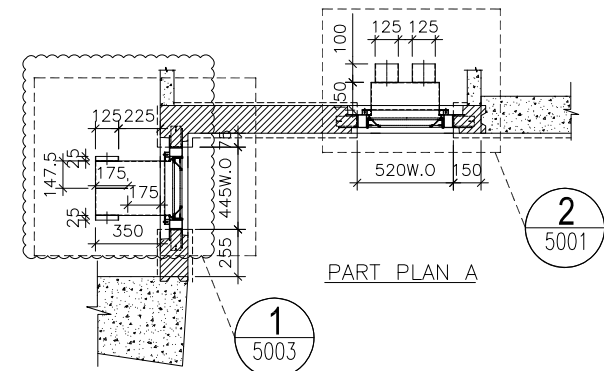
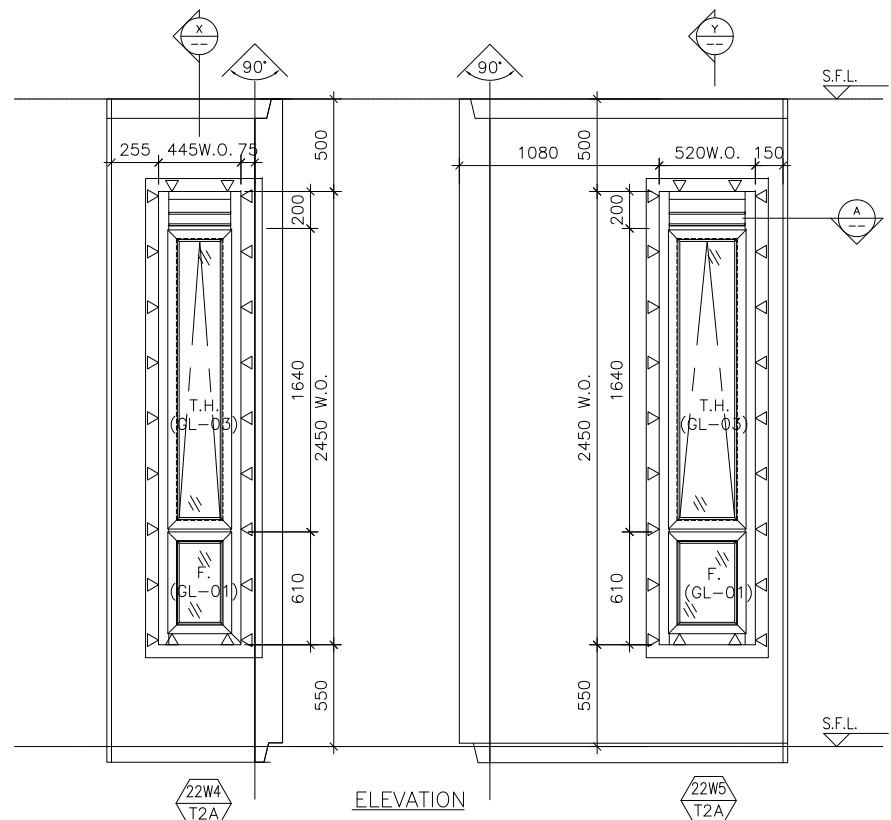

WINDOW MARK	22W4 T2A / 22W5 T2A
LOCATION	22/F M.B. & EN.B. AT TOWER 2 FLAT A
SECTION	70mm ALUM. SECTION
GLAZING	GL-01, GL-03
QUANTITY	1
REMARKS	FACADE (PF-35)

B.D. REF :

CLIENT :

ARCHITECT :
AGC DESIGN LTD
 101, 102, 103, 104, 105, 106, 107, 108, 109, 110, 111, 112, 113, 114, 115, 116, 117, 118, 119, 120, 121, 122, 123, 124, 125, 126, 127, 128, 129, 130, 131, 132, 133, 134, 135, 136, 137, 138, 139, 140, 141, 142, 143, 144, 145, 146, 147, 148, 149, 150, 151, 152, 153, 154, 155, 156, 157, 158, 159, 160, 161, 162, 163, 164, 165, 166, 167, 168, 169, 170, 171, 172, 173, 174, 175, 176, 177, 178, 179, 180, 181, 182, 183, 184, 185, 186, 187, 188, 189, 190, 191, 192, 193, 194, 195, 196, 197, 198, 199, 200, 201, 202, 203, 204, 205, 206, 207, 208, 209, 210, 211, 212, 213, 214, 215, 216, 217, 218, 219, 220, 221, 222, 223, 224, 225, 226, 227, 228, 229, 230, 231, 232, 233, 234, 235, 236, 237, 238, 239, 240, 241, 242, 243, 244, 245, 246, 247, 248, 249, 250, 251, 252, 253, 254, 255, 256, 257, 258, 259, 260, 261, 262, 263, 264, 265, 266, 267, 268, 269, 270, 271, 272, 273, 274, 275, 276, 277, 278, 279, 280, 281, 282, 283, 284, 285, 286, 287, 288, 289, 290, 291, 292, 293, 294, 295, 296, 297, 298, 299, 300, 301, 302, 303, 304, 305, 306, 307, 308, 309, 310, 311, 312, 313, 314, 315, 316, 317, 318, 319, 320, 321, 322, 323, 324, 325, 326, 327, 328, 329, 330, 331, 332, 333, 334, 335, 336, 337, 338, 339, 340, 341, 342, 343, 344, 345, 346, 347, 348, 349, 350, 351, 352, 353, 354, 355, 356, 357, 358, 359, 360, 361, 362, 363, 364, 365, 366, 367, 368, 369, 370, 371, 372, 373, 374, 375, 376, 377, 378, 379, 380, 381, 382, 383, 384, 385, 386, 387, 388, 389, 390, 391, 392, 393, 394, 395, 396, 397, 398, 399, 400, 401, 402, 403, 404, 405, 406, 407, 408, 409, 410, 411, 412, 413, 414, 415, 416, 417, 418, 419, 420, 421, 422, 423, 424, 425, 426, 427, 428, 429, 430, 431, 432, 433, 434, 435, 436, 437, 438, 439, 440, 441, 442, 443, 444, 445, 446, 447, 448, 449, 450, 451, 452, 453, 454, 455, 456, 457, 458, 459, 460, 461, 462, 463, 464, 465, 466, 467, 468, 469, 470, 471, 472, 473, 474, 475, 476, 477, 478, 479, 480, 481, 482, 483, 484, 485, 486, 487, 488, 489, 490, 491, 492, 493, 494, 495, 496, 497, 498, 499, 500, 501, 502, 503, 504, 505, 506, 507, 508, 509, 510, 511, 512, 513, 514, 515, 516, 517, 518, 519, 520, 521, 522, 523, 524, 525, 526, 527, 528, 529, 530, 531, 532, 533, 534, 535, 536, 537, 538, 539, 540, 541, 542, 543, 544, 545, 546, 547, 548, 549, 550, 551, 552, 553, 554, 555, 556, 557, 558, 559, 560, 561, 562, 563, 564, 565, 566, 567, 568, 569, 570, 571, 572, 573, 574, 575, 576, 577, 578, 579, 580, 581, 582, 583, 584, 585, 586, 587, 588, 589, 590, 591, 592, 593, 594, 595, 596, 597, 598, 599, 600, 601, 602, 603, 604, 605, 606, 607, 608, 609, 610, 611, 612, 613, 614, 615, 616, 617, 618, 619, 620, 621, 622, 623, 624, 625, 626, 627, 628, 629, 630, 631, 632, 633, 634, 635, 636, 637, 638, 639, 640, 641, 642, 643, 644, 645, 646, 647, 648, 649, 650, 651, 652, 653, 654, 655, 656, 657, 658, 659, 660, 661, 662, 663, 664, 665, 666, 667, 668, 669, 670, 671, 672, 673, 674, 675, 676, 677, 678, 679, 680, 681, 682, 683, 684, 685, 686, 687, 688, 689, 690, 691, 692, 693, 694, 695, 696, 697, 698, 699, 700, 701, 702, 703, 704, 705, 706, 707, 708, 709, 710, 711, 712, 713, 714, 715, 716, 717, 718, 719, 720, 721, 722, 723, 724, 725, 726, 727, 728, 729, 730, 731, 732, 733, 734, 735, 736, 737, 738, 739, 740, 741, 742, 743, 744, 745, 746, 747, 748, 749, 750, 751, 752, 753, 754, 755, 756, 757, 758, 759, 760, 761, 762, 763, 764, 765, 766, 767, 768, 769, 770, 771, 772, 773, 774, 775, 776, 777, 778, 779, 780, 781, 782, 783, 784, 785, 786, 787, 788, 789, 790, 791, 792, 793, 794, 795, 796, 797, 798, 799, 800, 801, 802, 803, 804, 805, 806, 807, 808, 809, 810, 811, 812, 813, 814, 815, 816, 817, 818, 819, 820, 821, 822, 823, 824, 825, 826, 827, 828, 829, 830, 831, 832, 833, 834, 835, 836, 837, 838, 839, 840, 841, 842, 843, 844, 845, 846, 847, 848, 849, 850, 851, 852, 853, 854, 855, 856, 857, 858, 859, 860, 861, 862, 863, 864, 865, 866, 867, 868, 869, 870, 871, 872, 873, 874, 875, 876, 877, 878, 879, 880, 881, 882, 883, 884, 885, 886, 887, 888, 889, 890, 891, 892, 893, 894, 895, 896, 897, 898, 899, 900, 901, 902, 903, 904, 905, 906, 907, 908, 909, 910, 911, 912, 913, 914, 915, 916, 917, 918, 919, 920, 921, 922, 923, 924, 925, 926, 927, 928, 929, 930, 931, 932, 933, 934, 935, 936, 937, 938, 939, 940, 941, 942, 943, 944, 945, 946, 947, 948, 949, 950, 951, 952, 953, 954, 955, 956, 957, 958, 959, 960, 961, 962, 963, 964, 965, 966, 967, 968, 969, 970, 971, 972, 973, 974, 975, 976, 977, 978, 979, 980, 981, 982, 983, 984, 985, 986, 987, 988, 989, 990, 991, 992, 993, 994, 995, 996, 997, 998, 999, 1000

MAIN CONTRACTOR :
Gammon

STRUCTURAL ENGINEER :
ARUP

FACADE CONSULTANT:
MEINHARDT

NOTE :
 1. ALL DIMENSIONS ARE IN mm.
 2. ALL ELEVATIONS ARE VIEWED FROM OUTSIDE.
 3. ALL DIMENSIONS TO BE VERIFIED ON SITE BEFORE FABRICATION.

LEGEND :
 x1 -- DETAIL MARK NO.
 x001 -- REFER SHEET NO.

1. F.F.L. -- FINISHED FLOOR LEVEL
 2. S.F.L. -- STRUCTURAL FLOOR LEVEL
 3. (R) -- REVERSED DETAIL
 4. ▲ -- FIXING LOCATION
 5. △ -- FIXING LUG LOCATION
 6. GLASS LEGEND
 GL01 -- 8mm+12mm AIR GAP+10mm THK. I.G.U.
 GL01a -- 8mm+9mm AIR GAP+10mm THK. I.G.U.
 GL03 -- 6mm+12mm AIR GAP+6mm THK. I.G.U.
 GL04 -- 10mm THK. TEMPERED GLASS (PROTECTIVE BARRIER)
 GL05 -- 6mm+12mm AIR GAP+8mm THK. I.G.U.

C	22/03/2021	REVISION SUBJECT TO ARCH.COMMENT	Ivan
B	06/01/2021	REVISION SUBJECT TO ARCH.COMMENT	Ivan
A	07/11/2020	REVISION SUBJECT TO ARCH.COMMENT	Ivan
NO.	DATE	REVISED	BY

JOB NO. : J-852
 PROJECT :
 PROPOSED RESIDENTIAL DEVELOPMENT
 AT 139 - 147 ARGYLE STREET,
 NKIL 6005, 6035 R.P., 6036 R.P.,
 6037 R.P. & 6038 R.P.

TITLE :
 SCHEDULE FOR Plenum Box
 AT TOWER 2 (22F)

DATE : 05-Dec-19 SCALE : 1:40
 DRAWN BY : MN CHECKED BY : DW

美特鋁質有限公司
MIDI ALUMINIUM FABRICATOR LTD.
 Units 6-8, Sunray Industrial Centre, 1/F
 610 Cha Kwo Ling Road, Kowloon
 Tel:23489211-4 Fax:(852)2727666

DWG NO. : J852-SD-PB-4207 REV. : C

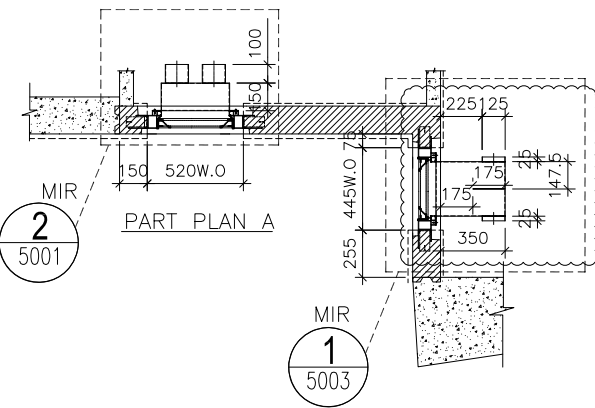
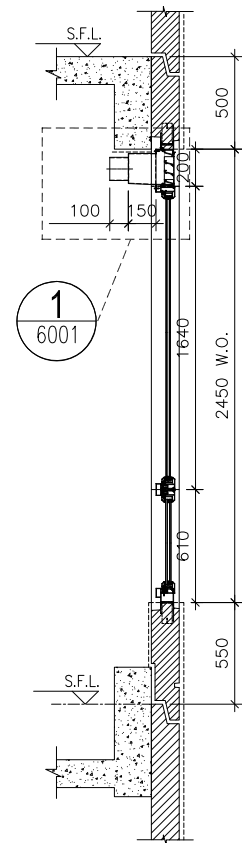
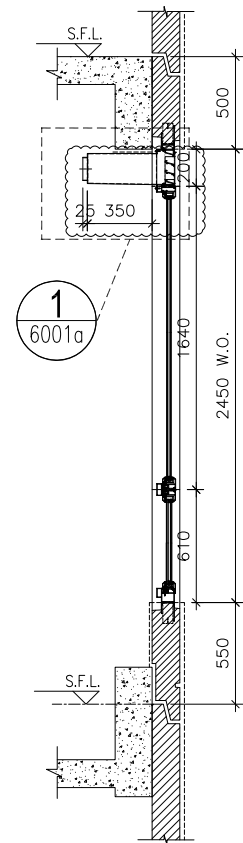
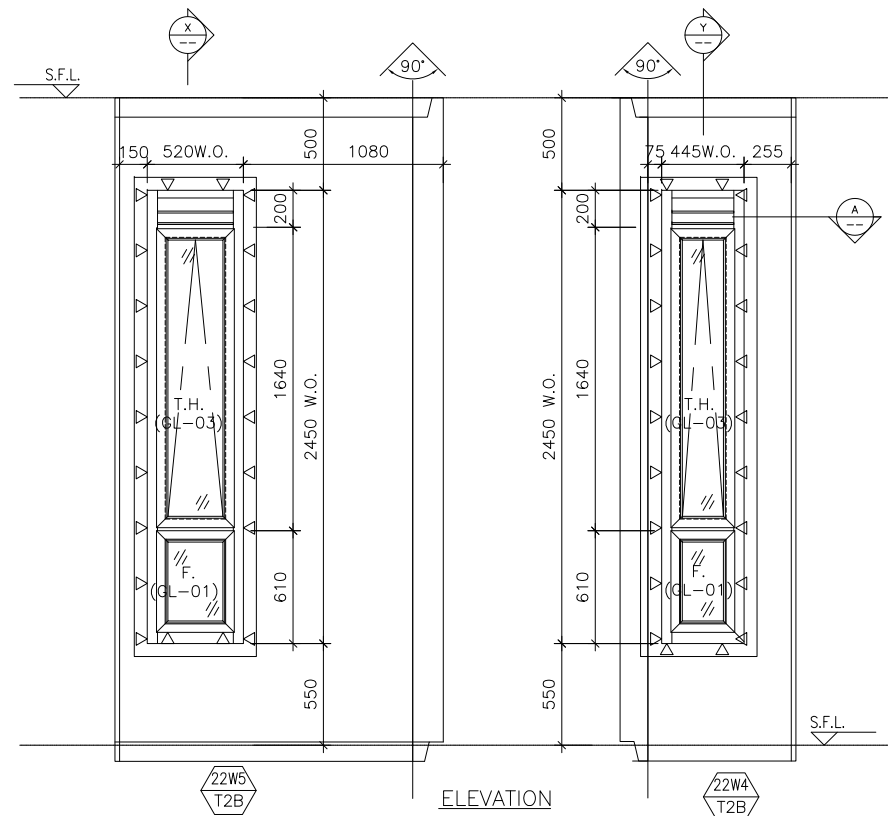

ELEVATION

SECTION "Y-Y"

SECTION "X-X"

WINDOW MARK	22W5 / 22W4 T2B / T2B
LOCATION	22/F M.B. & EN.B. AT TOWER 2 FLAT B
SECTION	70mm ALUM. SECTION
GLAZING	GL-01, GL-03
QUANTITY	1
REMARKS	FACADE (PF-36)

B.D. REF :

CLIENT :

ARCHITECT :
AGC DESIGN LTD

MAIN CONTRACTOR :
Gammon

STRUCTURAL ENGINEER :
ARUP

FACADE CONSULTANT:
MEINHARDT

NOTE :
1. ALL DIMENSIONS ARE IN mm.
2. ALL ELEVATIONS ARE VIEWED FROM OUTSIDE.
3. ALL DIMENSIONS TO BE VERIFIED ON SITE BEFORE FABRICATION.

LEGEND :
x1 — DETAIL MARK NO.
x001 — REFER SHEET NO.
1. F.F.L. — FINISHED FLOOR LEVEL
2. S.F.L. — STRUCTURAL FLOOR LEVEL
3. (R) — REVERSED DETAIL
4. ▲ — FIXING LOCATION
5. △ — FIXING LUG LOCATION
6. GLASS LEGEND
GL01 — 8mm+12mm AIR GAP+10mm THK. I.G.U.
GL01a — 8mm+9mm AIR GAP+10mm THK. I.G.U.
GL03 — 6mm+12mm AIR GAP+6mm THK. I.G.U.
GL04 — 10mm THK. TEMPERED GLASS (PROTECTIVE BARRIER)
GL05 — 6mm+12mm AIR GAP+8mm THK. I.G.U.

C	22/03/2021	REVISION SUBJECT TO ARCH.COMMENT	Ivan
B	06/01/2021	REVISION SUBJECT TO ARCH.COMMENT	Ivan
A	07/11/2020	REVISION SUBJECT TO ARCH.COMMENT	Ivan
NO.	DATE	REVISED	BY

JOB NO. : J-852
PROJECT : PROPOSED RESIDENTIAL DEVELOPMENT AT 139 - 147 ARGYLE STREET, NKIL 6005, 6035 R.P., 6036 R.P., 6037 R.P. & 6038 R.P.

TITLE : SCHEDULE FOR Plenum Box AT TOWER 2 (22F)

DATE : 05-Dec-19 SCALE : 1:40
DRAWN BY : MN CHECKED BY : DW

美特鋁質有限公司
MIDI ALUMINIUM FABRICATOR LTD.
Units 6-8, Sunray Industrial Centre, 1/F
610 Cha Kwo Ling Road, Kowloon
Tel:23489211-4 Fax:(852)2727666
DWG NO. : J852-SD-PB-4208 REV. : C

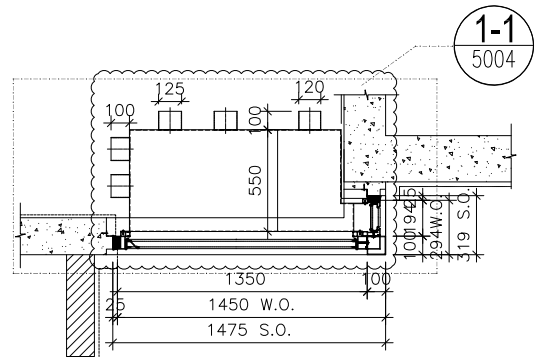
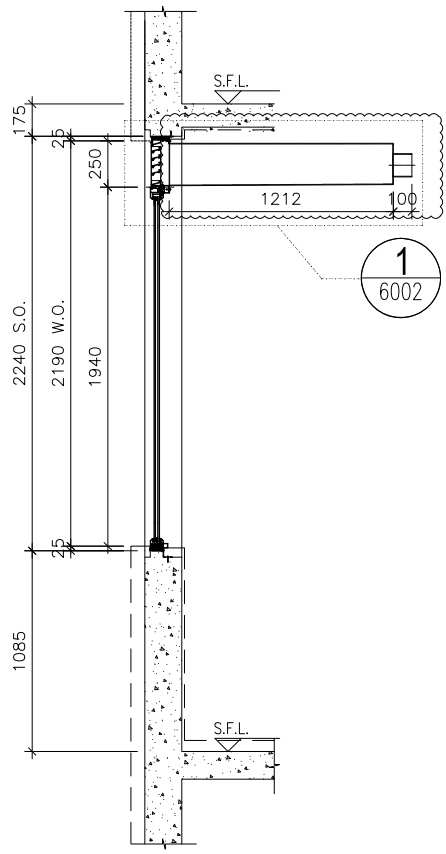
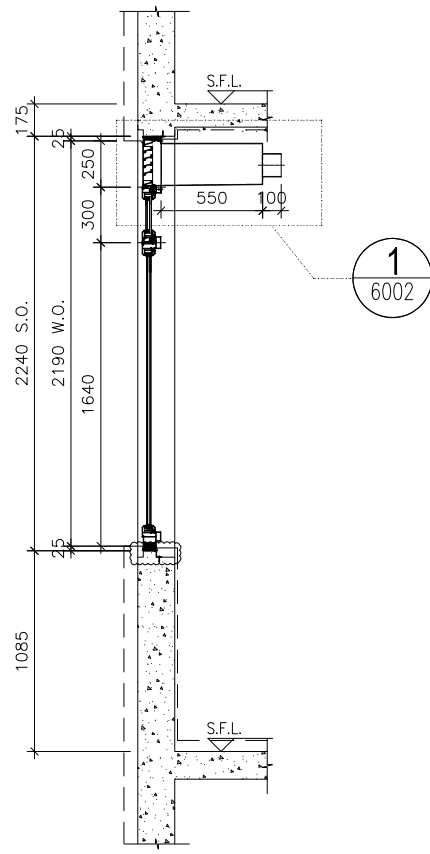
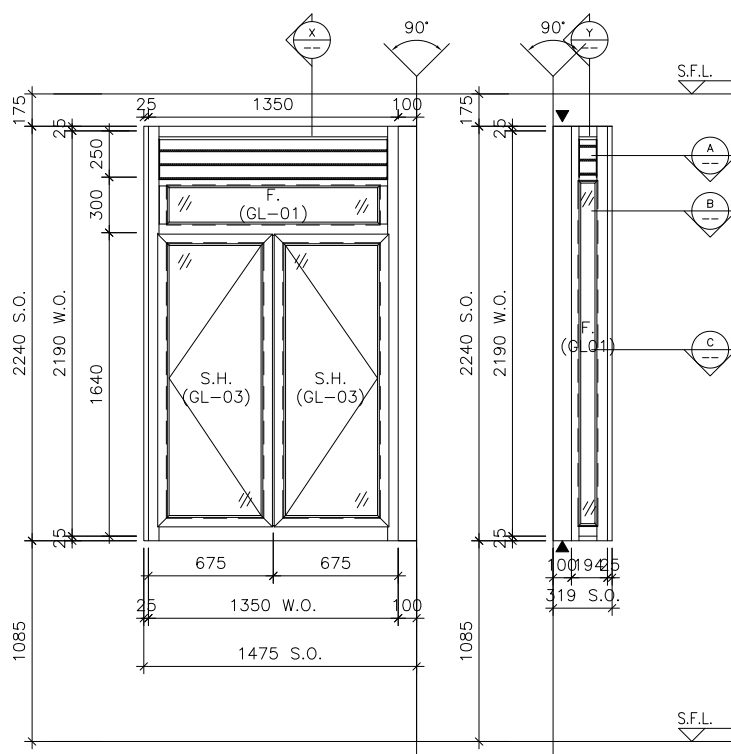

ELEVATION

ELEVATION

SECTION "X-X"

SECTION "Y-Y"

PART PLAN A

B.D. REF :

CLIENT :

ARCHITECT :
AGC DESIGN LTD
 101, 102, 103, 104, 105, 106, 107, 108, 109, 110, 111, 112, 113, 114, 115, 116, 117, 118, 119, 120, 121, 122, 123, 124, 125, 126, 127, 128, 129, 130, 131, 132, 133, 134, 135, 136, 137, 138, 139, 140, 141, 142, 143, 144, 145, 146, 147, 148, 149, 150, 151, 152, 153, 154, 155, 156, 157, 158, 159, 160, 161, 162, 163, 164, 165, 166, 167, 168, 169, 170, 171, 172, 173, 174, 175, 176, 177, 178, 179, 180, 181, 182, 183, 184, 185, 186, 187, 188, 189, 190, 191, 192, 193, 194, 195, 196, 197, 198, 199, 200, 201, 202, 203, 204, 205, 206, 207, 208, 209, 210, 211, 212, 213, 214, 215, 216, 217, 218, 219, 220, 221, 222, 223, 224, 225, 226, 227, 228, 229, 230, 231, 232, 233, 234, 235, 236, 237, 238, 239, 240, 241, 242, 243, 244, 245, 246, 247, 248, 249, 250, 251, 252, 253, 254, 255, 256, 257, 258, 259, 260, 261, 262, 263, 264, 265, 266, 267, 268, 269, 270, 271, 272, 273, 274, 275, 276, 277, 278, 279, 280, 281, 282, 283, 284, 285, 286, 287, 288, 289, 290, 291, 292, 293, 294, 295, 296, 297, 298, 299, 300, 301, 302, 303, 304, 305, 306, 307, 308, 309, 310, 311, 312, 313, 314, 315, 316, 317, 318, 319, 320, 321, 322, 323, 324, 325, 326, 327, 328, 329, 330, 331, 332, 333, 334, 335, 336, 337, 338, 339, 340, 341, 342, 343, 344, 345, 346, 347, 348, 349, 350, 351, 352, 353, 354, 355, 356, 357, 358, 359, 360, 361, 362, 363, 364, 365, 366, 367, 368, 369, 370, 371, 372, 373, 374, 375, 376, 377, 378, 379, 380, 381, 382, 383, 384, 385, 386, 387, 388, 389, 390, 391, 392, 393, 394, 395, 396, 397, 398, 399, 400, 401, 402, 403, 404, 405, 406, 407, 408, 409, 410, 411, 412, 413, 414, 415, 416, 417, 418, 419, 420, 421, 422, 423, 424, 425, 426, 427, 428, 429, 430, 431, 432, 433, 434, 435, 436, 437, 438, 439, 440, 441, 442, 443, 444, 445, 446, 447, 448, 449, 450, 451, 452, 453, 454, 455, 456, 457, 458, 459, 460, 461, 462, 463, 464, 465, 466, 467, 468, 469, 470, 471, 472, 473, 474, 475, 476, 477, 478, 479, 480, 481, 482, 483, 484, 485, 486, 487, 488, 489, 490, 491, 492, 493, 494, 495, 496, 497, 498, 499, 500, 501, 502, 503, 504, 505, 506, 507, 508, 509, 510, 511, 512, 513, 514, 515, 516, 517, 518, 519, 520, 521, 522, 523, 524, 525, 526, 527, 528, 529, 530, 531, 532, 533, 534, 535, 536, 537, 538, 539, 540, 541, 542, 543, 544, 545, 546, 547, 548, 549, 550, 551, 552, 553, 554, 555, 556, 557, 558, 559, 560, 561, 562, 563, 564, 565, 566, 567, 568, 569, 570, 571, 572, 573, 574, 575, 576, 577, 578, 579, 580, 581, 582, 583, 584, 585, 586, 587, 588, 589, 590, 591, 592, 593, 594, 595, 596, 597, 598, 599, 600, 601, 602, 603, 604, 605, 606, 607, 608, 609, 610, 611, 612, 613, 614, 615, 616, 617, 618, 619, 620, 621, 622, 623, 624, 625, 626, 627, 628, 629, 630, 631, 632, 633, 634, 635, 636, 637, 638, 639, 640, 641, 642, 643, 644, 645, 646, 647, 648, 649, 650, 651, 652, 653, 654, 655, 656, 657, 658, 659, 660, 661, 662, 663, 664, 665, 666, 667, 668, 669, 670, 671, 672, 673, 674, 675, 676, 677, 678, 679, 680, 681, 682, 683, 684, 685, 686, 687, 688, 689, 690, 691, 692, 693, 694, 695, 696, 697, 698, 699, 700, 701, 702, 703, 704, 705, 706, 707, 708, 709, 710, 711, 712, 713, 714, 715, 716, 717, 718, 719, 720, 721, 722, 723, 724, 725, 726, 727, 728, 729, 730, 731, 732, 733, 734, 735, 736, 737, 738, 739, 740, 741, 742, 743, 744, 745, 746, 747, 748, 749, 750, 751, 752, 753, 754, 755, 756, 757, 758, 759, 760, 761, 762, 763, 764, 765, 766, 767, 768, 769, 770, 771, 772, 773, 774, 775, 776, 777, 778, 779, 780, 781, 782, 783, 784, 785, 786, 787, 788, 789, 790, 791, 792, 793, 794, 795, 796, 797, 798, 799, 800, 801, 802, 803, 804, 805, 806, 807, 808, 809, 810, 811, 812, 813, 814, 815, 816, 817, 818, 819, 820, 821, 822, 823, 824, 825, 826, 827, 828, 829, 830, 831, 832, 833, 834, 835, 836, 837, 838, 839, 840, 841, 842, 843, 844, 845, 846, 847, 848, 849, 850, 851, 852, 853, 854, 855, 856, 857, 858, 859, 860, 861, 862, 863, 864, 865, 866, 867, 868, 869, 870, 871, 872, 873, 874, 875, 876, 877, 878, 879, 880, 881, 882, 883, 884, 885, 886, 887, 888, 889, 890, 891, 892, 893, 894, 895, 896, 897, 898, 899, 900, 901, 902, 903, 904, 905, 906, 907, 908, 909, 910, 911, 912, 913, 914, 915, 916, 917, 918, 919, 920, 921, 922, 923, 924, 925, 926, 927, 928, 929, 930, 931, 932, 933, 934, 935, 936, 937, 938, 939, 940, 941, 942, 943, 944, 945, 946, 947, 948, 949, 950, 951, 952, 953, 954, 955, 956, 957, 958, 959, 960, 961, 962, 963, 964, 965, 966, 967, 968, 969, 970, 971, 972, 973, 974, 975, 976, 977, 978, 979, 980, 981, 982, 983, 984, 985, 986, 987, 988, 989, 990, 991, 992, 993, 994, 995, 996, 997, 998, 999, 1000

MAIN CONTRACTOR :
Gammon

STRUCTURAL ENGINEER :
ARUP

FACADE CONSULTANT:
MEINHARDT

NOTE :
 1. ALL DIMENSIONS ARE IN mm.
 2. ALL ELEVATIONS ARE VIEWED FROM OUTSIDE.
 3. ALL DIMENSIONS TO BE VERIFIED ON SITE BEFORE FABRICATION.

LEGEND :
 (X1) --- DETAIL MARK NO.
 (X001) --- REFER SHEET NO.
 1. F.F.L. --- FINISHED FLOOR LEVEL
 2. S.F.L. --- STRUCTURAL FLOOR LEVEL
 3. (R) --- REVERSED DETAIL

NO.	DATE	REVISION	BY
A	09/12/2020	REVISION SUBJECT TO ARCH.COMMENT	Ivan

JOB NO. : J-852
 PROJECT :
 PROPOSED RESIDENTIAL DEVELOPMENT
 AT 139 - 147 ARGYLE STREET,
 NKIL 6005, 6035 R.P., 6036 R.P.,
 6037 R.P. & 6038 R.P.

TITLE :
 SCHEDULE FOR Plenum Box
 AT TOWER 2 (22F)

DATE : 05-FEB-20 SCALE : 1:100

DRAWN BY : MN CHECKED BY : DW

美特鋁質有限公司
MIDI ALUMINIUM FABRICATOR LTD.
 Units 6-8, Sunray Industrial Centre, 1/F
 610 Cha Kwo Ling Road, Kowloon
 Tel:23489211-4 Fax:(852)27727666

DWG NO. : J852-SD-PB-4209 REV. : A

WINDOW MARK



LOCATION 22/F KIT. AT TOWER 2 FLAT A

SECTION 50mm ALUM. SECTION

GLAZING GL-01, GL-03

QUANTITY 1

REMARKS

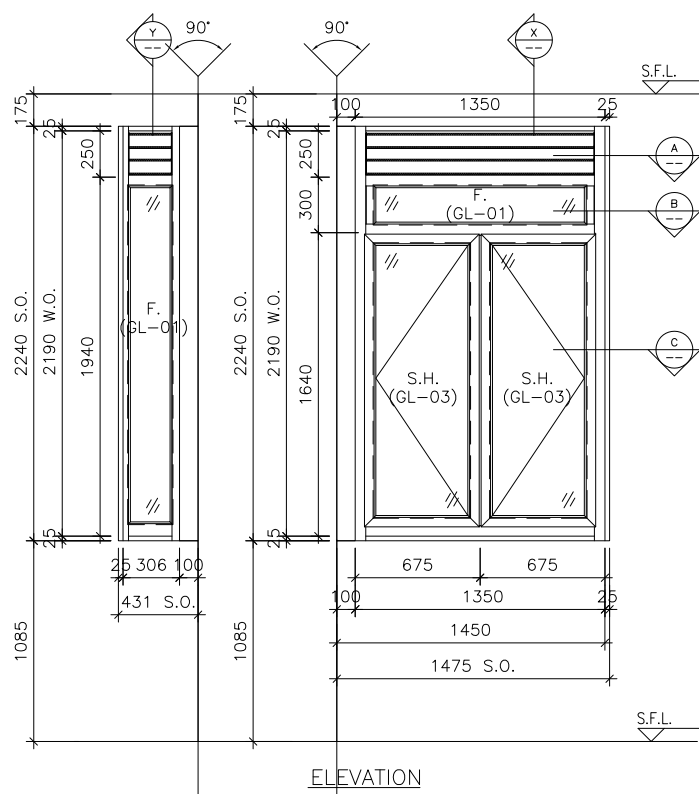

ELEVATION

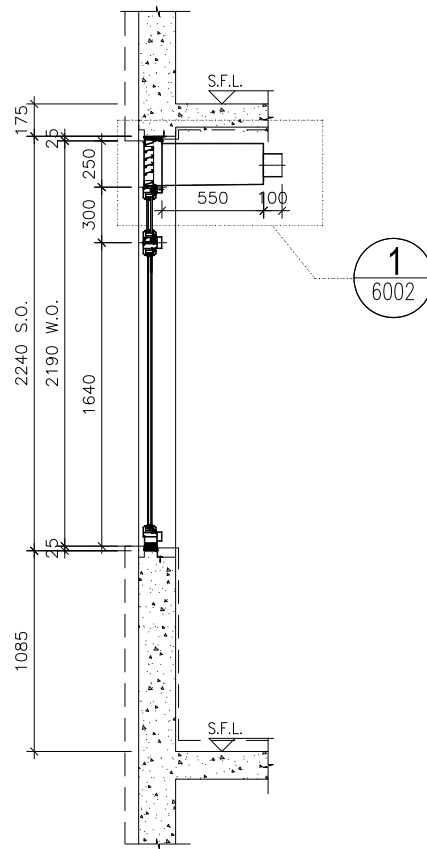

SECTION "X-X"

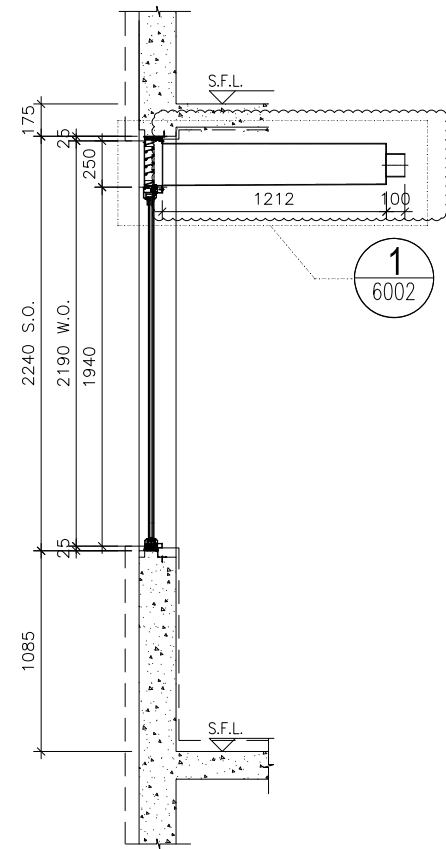

SECTION "Y-Y"

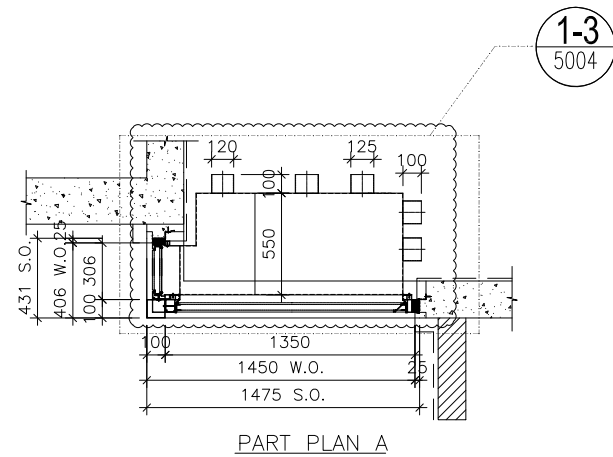

PART PLAN A

ELEVATION

WINDOW MARK	
LOCATION	22/F KIT. AT TOWER 2 FLAT B
SECTION	50mm ALUM. SECTION
GLAZING	GL-01, GL-03
QUANTITY	1
REMARKS	

B.D. REF :

CLIENT :

ARCHITECT :
AGC DESIGN LTD
 101, 102, 103, 104, 105, 106, 107, 108, 109, 110, 111, 112, 113, 114, 115, 116, 117, 118, 119, 120, 121, 122, 123, 124, 125, 126, 127, 128, 129, 130, 131, 132, 133, 134, 135, 136, 137, 138, 139, 140, 141, 142, 143, 144, 145, 146, 147, 148, 149, 150, 151, 152, 153, 154, 155, 156, 157, 158, 159, 160, 161, 162, 163, 164, 165, 166, 167, 168, 169, 170, 171, 172, 173, 174, 175, 176, 177, 178, 179, 180, 181, 182, 183, 184, 185, 186, 187, 188, 189, 190, 191, 192, 193, 194, 195, 196, 197, 198, 199, 200, 201, 202, 203, 204, 205, 206, 207, 208, 209, 210, 211, 212, 213, 214, 215, 216, 217, 218, 219, 220, 221, 222, 223, 224, 225, 226, 227, 228, 229, 230, 231, 232, 233, 234, 235, 236, 237, 238, 239, 240, 241, 242, 243, 244, 245, 246, 247, 248, 249, 250, 251, 252, 253, 254, 255, 256, 257, 258, 259, 260, 261, 262, 263, 264, 265, 266, 267, 268, 269, 270, 271, 272, 273, 274, 275, 276, 277, 278, 279, 280, 281, 282, 283, 284, 285, 286, 287, 288, 289, 290, 291, 292, 293, 294, 295, 296, 297, 298, 299, 300, 301, 302, 303, 304, 305, 306, 307, 308, 309, 310, 311, 312, 313, 314, 315, 316, 317, 318, 319, 320, 321, 322, 323, 324, 325, 326, 327, 328, 329, 330, 331, 332, 333, 334, 335, 336, 337, 338, 339, 340, 341, 342, 343, 344, 345, 346, 347, 348, 349, 350, 351, 352, 353, 354, 355, 356, 357, 358, 359, 360, 361, 362, 363, 364, 365, 366, 367, 368, 369, 370, 371, 372, 373, 374, 375, 376, 377, 378, 379, 380, 381, 382, 383, 384, 385, 386, 387, 388, 389, 390, 391, 392, 393, 394, 395, 396, 397, 398, 399, 400, 401, 402, 403, 404, 405, 406, 407, 408, 409, 410, 411, 412, 413, 414, 415, 416, 417, 418, 419, 420, 421, 422, 423, 424, 425, 426, 427, 428, 429, 430, 431, 432, 433, 434, 435, 436, 437, 438, 439, 440, 441, 442, 443, 444, 445, 446, 447, 448, 449, 450, 451, 452, 453, 454, 455, 456, 457, 458, 459, 460, 461, 462, 463, 464, 465, 466, 467, 468, 469, 470, 471, 472, 473, 474, 475, 476, 477, 478, 479, 480, 481, 482, 483, 484, 485, 486, 487, 488, 489, 490, 491, 492, 493, 494, 495, 496, 497, 498, 499, 500, 501, 502, 503, 504, 505, 506, 507, 508, 509, 510, 511, 512, 513, 514, 515, 516, 517, 518, 519, 520, 521, 522, 523, 524, 525, 526, 527, 528, 529, 530, 531, 532, 533, 534, 535, 536, 537, 538, 539, 540, 541, 542, 543, 544, 545, 546, 547, 548, 549, 550, 551, 552, 553, 554, 555, 556, 557, 558, 559, 560, 561, 562, 563, 564, 565, 566, 567, 568, 569, 570, 571, 572, 573, 574, 575, 576, 577, 578, 579, 580, 581, 582, 583, 584, 585, 586, 587, 588, 589, 590, 591, 592, 593, 594, 595, 596, 597, 598, 599, 600, 601, 602, 603, 604, 605, 606, 607, 608, 609, 610, 611, 612, 613, 614, 615, 616, 617, 618, 619, 620, 621, 622, 623, 624, 625, 626, 627, 628, 629, 630, 631, 632, 633, 634, 635, 636, 637, 638, 639, 640, 641, 642, 643, 644, 645, 646, 647, 648, 649, 650, 651, 652, 653, 654, 655, 656, 657, 658, 659, 660, 661, 662, 663, 664, 665, 666, 667, 668, 669, 670, 671, 672, 673, 674, 675, 676, 677, 678, 679, 680, 681, 682, 683, 684, 685, 686, 687, 688, 689, 690, 691, 692, 693, 694, 695, 696, 697, 698, 699, 700, 701, 702, 703, 704, 705, 706, 707, 708, 709, 710, 711, 712, 713, 714, 715, 716, 717, 718, 719, 720, 721, 722, 723, 724, 725, 726, 727, 728, 729, 730, 731, 732, 733, 734, 735, 736, 737, 738, 739, 740, 741, 742, 743, 744, 745, 746, 747, 748, 749, 750, 751, 752, 753, 754, 755, 756, 757, 758, 759, 760, 761, 762, 763, 764, 765, 766, 767, 768, 769, 770, 771, 772, 773, 774, 775, 776, 777, 778, 779, 780, 781, 782, 783, 784, 785, 786, 787, 788, 789, 790, 791, 792, 793, 794, 795, 796, 797, 798, 799, 800, 801, 802, 803, 804, 805, 806, 807, 808, 809, 810, 811, 812, 813, 814, 815, 816, 817, 818, 819, 820, 821, 822, 823, 824, 825, 826, 827, 828, 829, 830, 831, 832, 833, 834, 835, 836, 837, 838, 839, 840, 841, 842, 843, 844, 845, 846, 847, 848, 849, 850, 851, 852, 853, 854, 855, 856, 857, 858, 859, 860, 861, 862, 863, 864, 865, 866, 867, 868, 869, 870, 871, 872, 873, 874, 875, 876, 877, 878, 879, 880, 881, 882, 883, 884, 885, 886, 887, 888, 889, 890, 891, 892, 893, 894, 895, 896, 897, 898, 899, 900, 901, 902, 903, 904, 905, 906, 907, 908, 909, 910, 911, 912, 913, 914, 915, 916, 917, 918, 919, 920, 921, 922, 923, 924, 925, 926, 927, 928, 929, 930, 931, 932, 933, 934, 935, 936, 937, 938, 939, 940, 941, 942, 943, 944, 945, 946, 947, 948, 949, 950, 951, 952, 953, 954, 955, 956, 957, 958, 959, 960, 961, 962, 963, 964, 965, 966, 967, 968, 969, 970, 971, 972, 973, 974, 975, 976, 977, 978, 979, 980, 981, 982, 983, 984, 985, 986, 987, 988, 989, 990, 991, 992, 993, 994, 995, 996, 997, 998, 999, 1000

MAIN CONTRACTOR :
Gammon

STRUCTURAL ENGINEER :
ARUP

FACADE CONSULTANT:
MEINHARDT

NOTE :

1. ALL DIMENSIONS ARE IN mm.
2. ALL ELEVATIONS ARE VIEWED FROM OUTSIDE.
3. ALL DIMENSIONS TO BE VERIFIED ON SITE BEFORE FABRICATION.

LEGEND :

(x1) --- DETAIL MARK NO.
 (x001) --- REFER SHEET NO.

1. F.F.L. --- FINISHED FLOOR LEVEL
2. S.F.L. --- STRUCTURAL FLOOR LEVEL
3. (R) --- REVERSED DETAIL

NO.	DATE	REVISION	BY
A	09/12/2020	REVISION SUBJECT TO ARCH.COMMENT	Ivan

JOB NO. : J-852

PROJECT :
 PROPOSED RESIDENTIAL DEVELOPMENT
 AT 139 - 147 ARGYLE STREET,
 NKIL 6005, 6035 R.P., 6036 R.P.,
 6037 R.P. & 6038 R.P.

TITLE :
 SCHEDULE FOR Plenum Box
 AT TOWER 2 (22F)

DATE : 05-FEB-20 SCALE : 1:100

DRAWN BY : MN CHECKED BY : DW

美特鋁質有限公司
MIDI ALUMINIUM FABRICATOR LTD.
 Units 6-8, Sunray Industrial Centre, 1/F
 610 Cha Kwo Ling Road, Kowloon
 Tel:23489211-4 Fax:(852)2727666

DWG NO. : J852-SD-PB-4210 REV. : A

ELEVATION

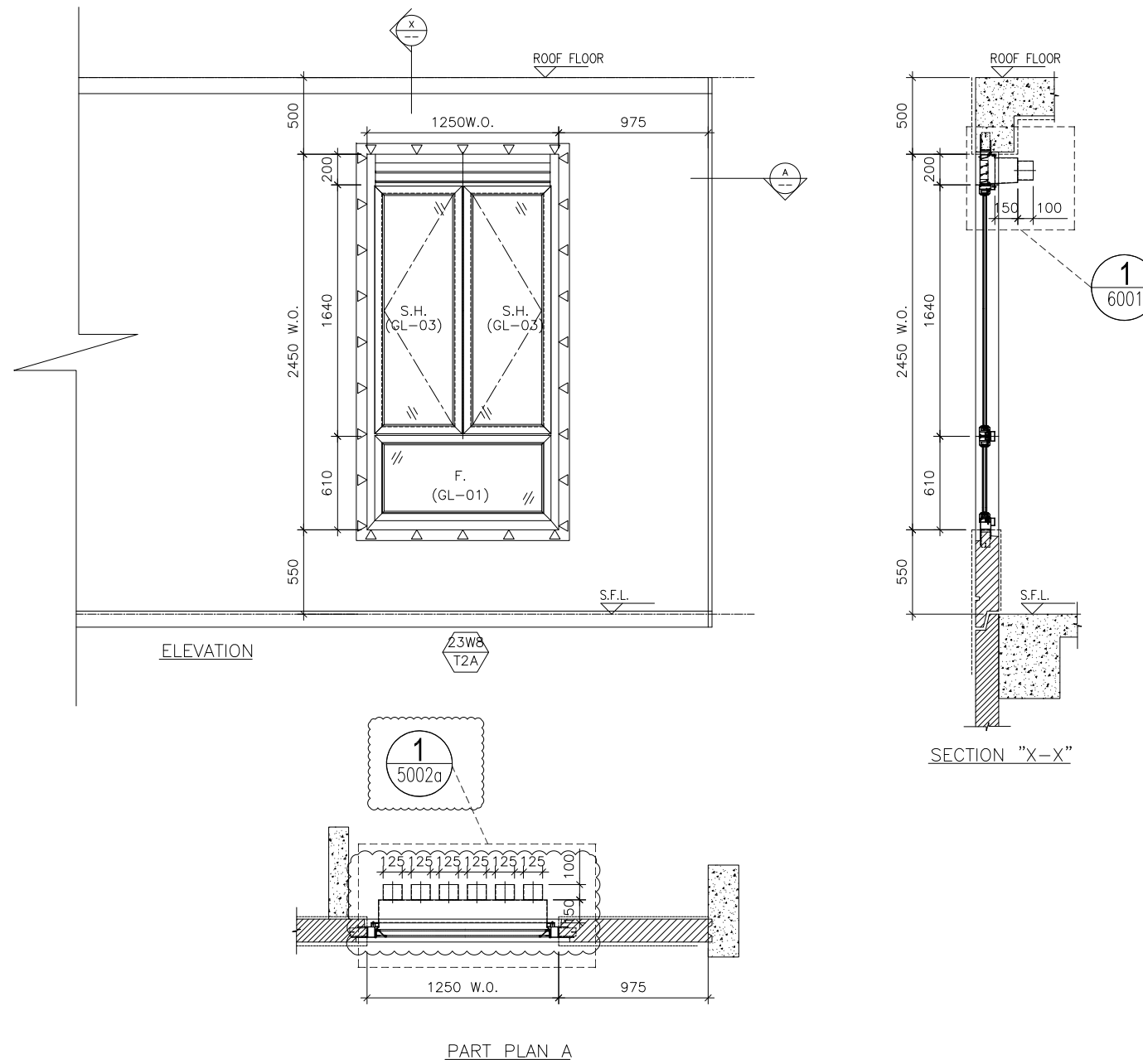

B.D. REF :

CLIENT :

ARCHITECT :
AGC DESIGN LTD
 101, 102, 103, 104, 105, 106, 107, 108, 109, 110, 111, 112, 113, 114, 115, 116, 117, 118, 119, 120, 121, 122, 123, 124, 125, 126, 127, 128, 129, 130, 131, 132, 133, 134, 135, 136, 137, 138, 139, 140, 141, 142, 143, 144, 145, 146, 147, 148, 149, 150, 151, 152, 153, 154, 155, 156, 157, 158, 159, 160, 161, 162, 163, 164, 165, 166, 167, 168, 169, 170, 171, 172, 173, 174, 175, 176, 177, 178, 179, 180, 181, 182, 183, 184, 185, 186, 187, 188, 189, 190, 191, 192, 193, 194, 195, 196, 197, 198, 199, 200, 201, 202, 203, 204, 205, 206, 207, 208, 209, 210, 211, 212, 213, 214, 215, 216, 217, 218, 219, 220, 221, 222, 223, 224, 225, 226, 227, 228, 229, 230, 231, 232, 233, 234, 235, 236, 237, 238, 239, 240, 241, 242, 243, 244, 245, 246, 247, 248, 249, 250, 251, 252, 253, 254, 255, 256, 257, 258, 259, 260, 261, 262, 263, 264, 265, 266, 267, 268, 269, 270, 271, 272, 273, 274, 275, 276, 277, 278, 279, 280, 281, 282, 283, 284, 285, 286, 287, 288, 289, 290, 291, 292, 293, 294, 295, 296, 297, 298, 299, 300, 301, 302, 303, 304, 305, 306, 307, 308, 309, 310, 311, 312, 313, 314, 315, 316, 317, 318, 319, 320, 321, 322, 323, 324, 325, 326, 327, 328, 329, 330, 331, 332, 333, 334, 335, 336, 337, 338, 339, 340, 341, 342, 343, 344, 345, 346, 347, 348, 349, 350, 351, 352, 353, 354, 355, 356, 357, 358, 359, 360, 361, 362, 363, 364, 365, 366, 367, 368, 369, 370, 371, 372, 373, 374, 375, 376, 377, 378, 379, 380, 381, 382, 383, 384, 385, 386, 387, 388, 389, 390, 391, 392, 393, 394, 395, 396, 397, 398, 399, 400, 401, 402, 403, 404, 405, 406, 407, 408, 409, 410, 411, 412, 413, 414, 415, 416, 417, 418, 419, 420, 421, 422, 423, 424, 425, 426, 427, 428, 429, 430, 431, 432, 433, 434, 435, 436, 437, 438, 439, 440, 441, 442, 443, 444, 445, 446, 447, 448, 449, 450, 451, 452, 453, 454, 455, 456, 457, 458, 459, 460, 461, 462, 463, 464, 465, 466, 467, 468, 469, 470, 471, 472, 473, 474, 475, 476, 477, 478, 479, 480, 481, 482, 483, 484, 485, 486, 487, 488, 489, 490, 491, 492, 493, 494, 495, 496, 497, 498, 499, 500, 501, 502, 503, 504, 505, 506, 507, 508, 509, 510, 511, 512, 513, 514, 515, 516, 517, 518, 519, 520, 521, 522, 523, 524, 525, 526, 527, 528, 529, 530, 531, 532, 533, 534, 535, 536, 537, 538, 539, 540, 541, 542, 543, 544, 545, 546, 547, 548, 549, 550, 551, 552, 553, 554, 555, 556, 557, 558, 559, 560, 561, 562, 563, 564, 565, 566, 567, 568, 569, 570, 571, 572, 573, 574, 575, 576, 577, 578, 579, 580, 581, 582, 583, 584, 585, 586, 587, 588, 589, 590, 591, 592, 593, 594, 595, 596, 597, 598, 599, 600, 601, 602, 603, 604, 605, 606, 607, 608, 609, 610, 611, 612, 613, 614, 615, 616, 617, 618, 619, 620, 621, 622, 623, 624, 625, 626, 627, 628, 629, 630, 631, 632, 633, 634, 635, 636, 637, 638, 639, 640, 641, 642, 643, 644, 645, 646, 647, 648, 649, 650, 651, 652, 653, 654, 655, 656, 657, 658, 659, 660, 661, 662, 663, 664, 665, 666, 667, 668, 669, 670, 671, 672, 673, 674, 675, 676, 677, 678, 679, 680, 681, 682, 683, 684, 685, 686, 687, 688, 689, 690, 691, 692, 693, 694, 695, 696, 697, 698, 699, 700, 701, 702, 703, 704, 705, 706, 707, 708, 709, 710, 711, 712, 713, 714, 715, 716, 717, 718, 719, 720, 721, 722, 723, 724, 725, 726, 727, 728, 729, 730, 731, 732, 733, 734, 735, 736, 737, 738, 739, 740, 741, 742, 743, 744, 745, 746, 747, 748, 749, 750, 751, 752, 753, 754, 755, 756, 757, 758, 759, 760, 761, 762, 763, 764, 765, 766, 767, 768, 769, 770, 771, 772, 773, 774, 775, 776, 777, 778, 779, 780, 781, 782, 783, 784, 785, 786, 787, 788, 789, 790, 791, 792, 793, 794, 795, 796, 797, 798, 799, 800, 801, 802, 803, 804, 805, 806, 807, 808, 809, 810, 811, 812, 813, 814, 815, 816, 817, 818, 819, 820, 821, 822, 823, 824, 825, 826, 827, 828, 829, 830, 831, 832, 833, 834, 835, 836, 837, 838, 839, 840, 841, 842, 843, 844, 845, 846, 847, 848, 849, 850, 851, 852, 853, 854, 855, 856, 857, 858, 859, 860, 861, 862, 863, 864, 865, 866, 867, 868, 869, 870, 871, 872, 873, 874, 875, 876, 877, 878, 879, 880, 881, 882, 883, 884, 885, 886, 887, 888, 889, 890, 891, 892, 893, 894, 895, 896, 897, 898, 899, 900, 901, 902, 903, 904, 905, 906, 907, 908, 909, 910, 911, 912, 913, 914, 915, 916, 917, 918, 919, 920, 921, 922, 923, 924, 925, 926, 927, 928, 929, 930, 931, 932, 933, 934, 935, 936, 937, 938, 939, 940, 941, 942, 943, 944, 945, 946, 947, 948, 949, 950, 951, 952, 953, 954, 955, 956, 957, 958, 959, 960, 961, 962, 963, 964, 965, 966, 967, 968, 969, 970, 971, 972, 973, 974, 975, 976, 977, 978, 979, 980, 981, 982, 983, 984, 985, 986, 987, 988, 989, 990, 991, 992, 993, 994, 995, 996, 997, 998, 999, 1000

MAIN CONTRACTOR :
Gammon

STRUCTURAL ENGINEER :
ARUP

FACADE CONSULTANT:
MEINHARDT

NOTE :
 1. ALL DIMENSIONS ARE IN mm.
 2. ALL ELEVATIONS ARE VIEWED FROM OUTSIDE.
 3. ALL DIMENSIONS TO BE VERIFIED ON SITE BEFORE FABRICATION.

LEGEND :
 x1 -- DETAIL MARK NO.
 x001 -- REFER SHEET NO.
 1. F.F.L. -- FINISHED FLOOR LEVEL
 2. S.F.L. -- STRUCTURAL FLOOR LEVEL
 3. (R) -- REVERSED DETAIL
 4. ▲ -- FIXING LOCATION
 5. △ -- FIXING LUG LOCATION
 6. GLASS LEGEND
 GL01 -- 8mm+12mm AIR GAP+10mm THK. I.G.U.
 GL01a -- 8mm+12mm AIR GAP+10mm THK. I.G.U.
 GL03 -- 6mm+12mm AIR GAP+6mm THK. I.G.U.
 GL04 -- 10mm THK. TEMPERED GLASS (PROTECTIVE BARRIER)
 GL05 -- 6mm+12mm AIR GAP+8mm THK. I.G.U.

B	06/01/2021	REVISION SUBJECT TO ARCH.COMMENT	Ivan
A	07/11/2020	REVISION SUBJECT TO ARCH.COMMENT	Ivan
NO.	DATE	REVISED	BY

JOB NO. : J-852
 PROJECT :
 PROPOSED RESIDENTIAL DEVELOPMENT
 AT 139 - 147 ARGYLE STREET,
 NKIL 6005, 6035 R.P., 6036 R.P.,
 6037 R.P. & 6038 R.P.
 TITLE :
 SCHEDULE FOR Plenum Box
 AT TOWER 2 (23F)

DATE : 05-Dec-19 SCALE : 1:40
 DRAWN BY : MN CHECKED BY : DW

美特鋁質有限公司
MIDI ALUMINIUM FABRICATOR LTD.
 Units 6-8, Sunray Industrial Centre, 1/F
 610 Cha Kwo Ling Road, Kowloon
 Tel:23489211-4 Fax:(852)2727666

DWG NO. : J852-SD-PB-4211 REV. : B

WINDOW MARK	23WB T2A
LOCATION	23/F M.B. AT TOWER 2 FLAT A
SECTION	70mm ALUM. SECTION
GLAZING	GL-01, GL-03
QUANTITY	1
REMARKS	FACADE (PF-20)

ELEVATION

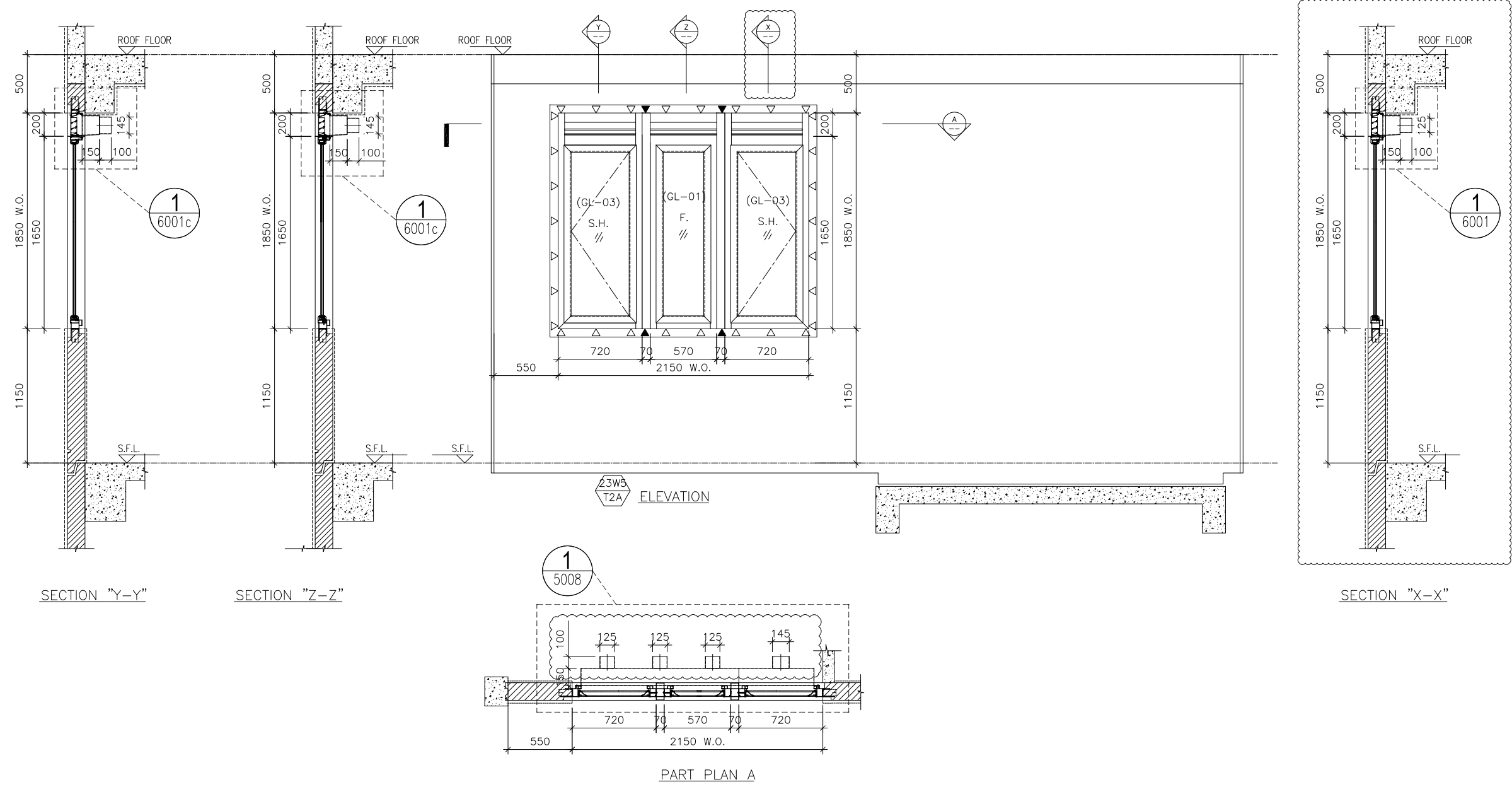

B.D. REF :

CLIENT :

ARCHITECT :
AGC DESIGN LTD
 180, 182, 184, 186, 188, 190, 192, 194, 196, 198, 200, 202, 204, 206, 208, 210, 212, 214, 216, 218, 220, 222, 224, 226, 228, 230, 232, 234, 236, 238, 240, 242, 244, 246, 248, 250, 252, 254, 256, 258, 260, 262, 264, 266, 268, 270, 272, 274, 276, 278, 280, 282, 284, 286, 288, 290, 292, 294, 296, 298, 300, 302, 304, 306, 308, 310, 312, 314, 316, 318, 320, 322, 324, 326, 328, 330, 332, 334, 336, 338, 340, 342, 344, 346, 348, 350, 352, 354, 356, 358, 360, 362, 364, 366, 368, 370, 372, 374, 376, 378, 380, 382, 384, 386, 388, 390, 392, 394, 396, 398, 400, 402, 404, 406, 408, 410, 412, 414, 416, 418, 420, 422, 424, 426, 428, 430, 432, 434, 436, 438, 440, 442, 444, 446, 448, 450, 452, 454, 456, 458, 460, 462, 464, 466, 468, 470, 472, 474, 476, 478, 480, 482, 484, 486, 488, 490, 492, 494, 496, 498, 500, 502, 504, 506, 508, 510, 512, 514, 516, 518, 520, 522, 524, 526, 528, 530, 532, 534, 536, 538, 540, 542, 544, 546, 548, 550, 552, 554, 556, 558, 560, 562, 564, 566, 568, 570, 572, 574, 576, 578, 580, 582, 584, 586, 588, 590, 592, 594, 596, 598, 600, 602, 604, 606, 608, 610, 612, 614, 616, 618, 620, 622, 624, 626, 628, 630, 632, 634, 636, 638, 640, 642, 644, 646, 648, 650, 652, 654, 656, 658, 660, 662, 664, 666, 668, 670, 672, 674, 676, 678, 680, 682, 684, 686, 688, 690, 692, 694, 696, 698, 700, 702, 704, 706, 708, 710, 712, 714, 716, 718, 720, 722, 724, 726, 728, 730, 732, 734, 736, 738, 740, 742, 744, 746, 748, 750, 752, 754, 756, 758, 760, 762, 764, 766, 768, 770, 772, 774, 776, 778, 780, 782, 784, 786, 788, 790, 792, 794, 796, 798, 800, 802, 804, 806, 808, 810, 812, 814, 816, 818, 820, 822, 824, 826, 828, 830, 832, 834, 836, 838, 840, 842, 844, 846, 848, 850, 852, 854, 856, 858, 860, 862, 864, 866, 868, 870, 872, 874, 876, 878, 880, 882, 884, 886, 888, 890, 892, 894, 896, 898, 900, 902, 904, 906, 908, 910, 912, 914, 916, 918, 920, 922, 924, 926, 928, 930, 932, 934, 936, 938, 940, 942, 944, 946, 948, 950, 952, 954, 956, 958, 960, 962, 964, 966, 968, 970, 972, 974, 976, 978, 980, 982, 984, 986, 988, 990, 992, 994, 996, 998, 1000

MAIN CONTRACTOR :
Gammon

STRUCTURAL ENGINEER :
ARUP

FACADE CONSULTANT:
MEINHARDT

NOTE :
 1. ALL DIMENSIONS ARE IN mm.
 2. ALL ELEVATIONS ARE VIEWED FROM OUTSIDE.
 3. ALL DIMENSIONS TO BE VERIFIED ON SITE BEFORE FABRICATION.

LEGEND :
 (X1) --- DETAIL MARK NO.
 (X001) --- REFER SHEET NO.
 1. F.F.L. --- FINISHED FLOOR LEVEL
 2. S.F.L. --- STRUCTURAL FLOOR LEVEL
 3. (R) --- REVERSED DETAIL
 4. (A) --- FIXING LOCATION
 5. (Δ) --- FIXING LUG LOCATION
 6. GLASS LEGEND
 GL01 --- 8mm+12mm AIR GAP+10mm THK. I.G.U.
 GL01a --- 8mm+12mm AIR GAP+10mm THK. I.G.U.
 GL03 --- 6mm+12mm AIR GAP+6mm THK. I.G.U.
 GL04 --- 10mm THK. TEMPERED GLASS (PROTECTIVE BARRIER)
 GL05 --- 6mm+12mm AIR GAP+8mm THK. I.G.U.

B	06/01/2021	REVISION SUBJECT TO ARCH.COMMENT	Ivan
A	09/12/2020	REVISION SUBJECT TO ARCH.COMMENT	Ivan
NO.	DATE	REVISED	BY

JOB NO. : J-852
 PROJECT :
 PROPOSED RESIDENTIAL DEVELOPMENT
 AT 139 - 147 ARGYLE STREET,
 NKIL 6005, 6035 R.P., 6036 R.P.,
 6037 R.P. & 6038 R.P.
 TITLE :
 SCHEDULE FOR Plenum Box
 AT TOWER 2 (23F)

DATE : 05-Dec-19 SCALE : 1:40
 DRAWN BY : MN CHECKED BY : DW

美特鋁質有限公司
MIDI ALUMINIUM FABRICATOR LTD.
 Units 6-8, Sunray Industrial Centre, 1/F
 610 Cha Kwo Ling Road, Kowloon
 Tel:23489211-4 Fax:(852)2727666
 DWG NO. : J852-SD-PB-4212 REV. : B

WINDOW MARK	23WB T2A
LOCATION	23/F KIT. AT TOWER 2 FLAT A
SECTION	70mm ALUM. SECTION
GLAZING	GL-01, GL-03
QUANTITY	1
REMARKS	FACADE (PF-21)

ELEVATION

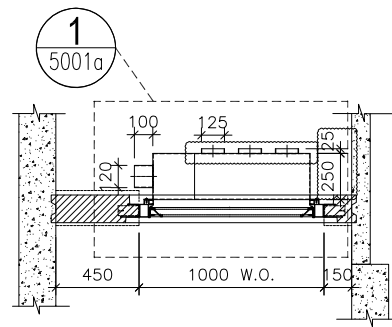
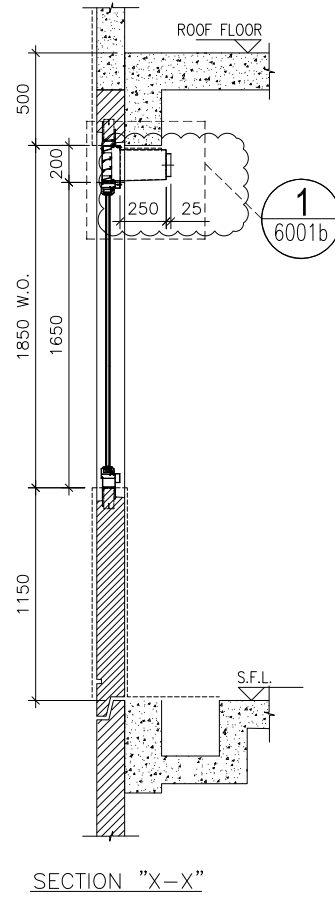
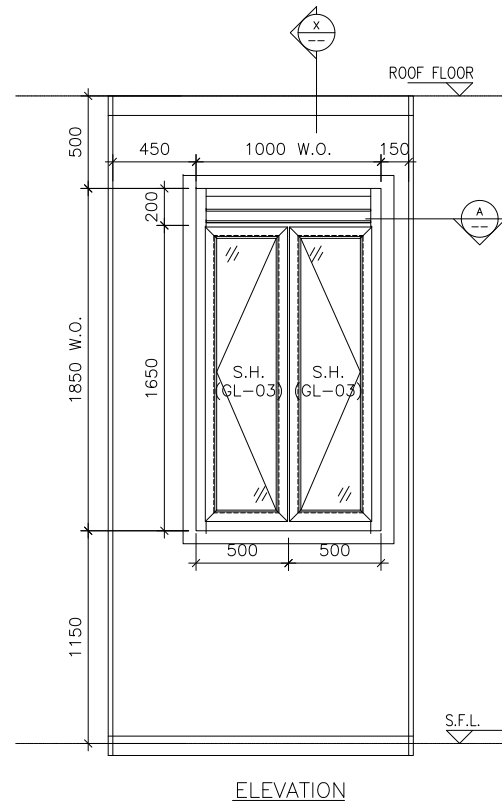

WINDOW MARK	
LOCATION	23/F KIT. AT TOWER 2 FLAT C
SECTION	70mm ALUM. SECTION
GLAZING	GL-03
QUANTITY	1
REMARKS	FACADE (PF-28)

B.D. REF :

CLIENT :

ARCHITECT :
AGC DESIGN LTD
 101, 102, 103, 104, 105, 106, 107, 108, 109, 110, 111, 112, 113, 114, 115, 116, 117, 118, 119, 120, 121, 122, 123, 124, 125, 126, 127, 128, 129, 130, 131, 132, 133, 134, 135, 136, 137, 138, 139, 140, 141, 142, 143, 144, 145, 146, 147, 148, 149, 150, 151, 152, 153, 154, 155, 156, 157, 158, 159, 160, 161, 162, 163, 164, 165, 166, 167, 168, 169, 170, 171, 172, 173, 174, 175, 176, 177, 178, 179, 180, 181, 182, 183, 184, 185, 186, 187, 188, 189, 190, 191, 192, 193, 194, 195, 196, 197, 198, 199, 200, 201, 202, 203, 204, 205, 206, 207, 208, 209, 210, 211, 212, 213, 214, 215, 216, 217, 218, 219, 220, 221, 222, 223, 224, 225, 226, 227, 228, 229, 230, 231, 232, 233, 234, 235, 236, 237, 238, 239, 240, 241, 242, 243, 244, 245, 246, 247, 248, 249, 250, 251, 252, 253, 254, 255, 256, 257, 258, 259, 260, 261, 262, 263, 264, 265, 266, 267, 268, 269, 270, 271, 272, 273, 274, 275, 276, 277, 278, 279, 280, 281, 282, 283, 284, 285, 286, 287, 288, 289, 290, 291, 292, 293, 294, 295, 296, 297, 298, 299, 300, 301, 302, 303, 304, 305, 306, 307, 308, 309, 310, 311, 312, 313, 314, 315, 316, 317, 318, 319, 320, 321, 322, 323, 324, 325, 326, 327, 328, 329, 330, 331, 332, 333, 334, 335, 336, 337, 338, 339, 340, 341, 342, 343, 344, 345, 346, 347, 348, 349, 350, 351, 352, 353, 354, 355, 356, 357, 358, 359, 360, 361, 362, 363, 364, 365, 366, 367, 368, 369, 370, 371, 372, 373, 374, 375, 376, 377, 378, 379, 380, 381, 382, 383, 384, 385, 386, 387, 388, 389, 390, 391, 392, 393, 394, 395, 396, 397, 398, 399, 400, 401, 402, 403, 404, 405, 406, 407, 408, 409, 410, 411, 412, 413, 414, 415, 416, 417, 418, 419, 420, 421, 422, 423, 424, 425, 426, 427, 428, 429, 430, 431, 432, 433, 434, 435, 436, 437, 438, 439, 440, 441, 442, 443, 444, 445, 446, 447, 448, 449, 450, 451, 452, 453, 454, 455, 456, 457, 458, 459, 460, 461, 462, 463, 464, 465, 466, 467, 468, 469, 470, 471, 472, 473, 474, 475, 476, 477, 478, 479, 480, 481, 482, 483, 484, 485, 486, 487, 488, 489, 490, 491, 492, 493, 494, 495, 496, 497, 498, 499, 500, 501, 502, 503, 504, 505, 506, 507, 508, 509, 510, 511, 512, 513, 514, 515, 516, 517, 518, 519, 520, 521, 522, 523, 524, 525, 526, 527, 528, 529, 530, 531, 532, 533, 534, 535, 536, 537, 538, 539, 540, 541, 542, 543, 544, 545, 546, 547, 548, 549, 550, 551, 552, 553, 554, 555, 556, 557, 558, 559, 560, 561, 562, 563, 564, 565, 566, 567, 568, 569, 570, 571, 572, 573, 574, 575, 576, 577, 578, 579, 580, 581, 582, 583, 584, 585, 586, 587, 588, 589, 590, 591, 592, 593, 594, 595, 596, 597, 598, 599, 600, 601, 602, 603, 604, 605, 606, 607, 608, 609, 610, 611, 612, 613, 614, 615, 616, 617, 618, 619, 620, 621, 622, 623, 624, 625, 626, 627, 628, 629, 630, 631, 632, 633, 634, 635, 636, 637, 638, 639, 640, 641, 642, 643, 644, 645, 646, 647, 648, 649, 650, 651, 652, 653, 654, 655, 656, 657, 658, 659, 660, 661, 662, 663, 664, 665, 666, 667, 668, 669, 670, 671, 672, 673, 674, 675, 676, 677, 678, 679, 680, 681, 682, 683, 684, 685, 686, 687, 688, 689, 690, 691, 692, 693, 694, 695, 696, 697, 698, 699, 700, 701, 702, 703, 704, 705, 706, 707, 708, 709, 710, 711, 712, 713, 714, 715, 716, 717, 718, 719, 720, 721, 722, 723, 724, 725, 726, 727, 728, 729, 730, 731, 732, 733, 734, 735, 736, 737, 738, 739, 740, 741, 742, 743, 744, 745, 746, 747, 748, 749, 750, 751, 752, 753, 754, 755, 756, 757, 758, 759, 760, 761, 762, 763, 764, 765, 766, 767, 768, 769, 770, 771, 772, 773, 774, 775, 776, 777, 778, 779, 780, 781, 782, 783, 784, 785, 786, 787, 788, 789, 790, 791, 792, 793, 794, 795, 796, 797, 798, 799, 800, 801, 802, 803, 804, 805, 806, 807, 808, 809, 810, 811, 812, 813, 814, 815, 816, 817, 818, 819, 820, 821, 822, 823, 824, 825, 826, 827, 828, 829, 830, 831, 832, 833, 834, 835, 836, 837, 838, 839, 840, 841, 842, 843, 844, 845, 846, 847, 848, 849, 850, 851, 852, 853, 854, 855, 856, 857, 858, 859, 860, 861, 862, 863, 864, 865, 866, 867, 868, 869, 870, 871, 872, 873, 874, 875, 876, 877, 878, 879, 880, 881, 882, 883, 884, 885, 886, 887, 888, 889, 890, 891, 892, 893, 894, 895, 896, 897, 898, 899, 900, 901, 902, 903, 904, 905, 906, 907, 908, 909, 910, 911, 912, 913, 914, 915, 916, 917, 918, 919, 920, 921, 922, 923, 924, 925, 926, 927, 928, 929, 930, 931, 932, 933, 934, 935, 936, 937, 938, 939, 940, 941, 942, 943, 944, 945, 946, 947, 948, 949, 950, 951, 952, 953, 954, 955, 956, 957, 958, 959, 960, 961, 962, 963, 964, 965, 966, 967, 968, 969, 970, 971, 972, 973, 974, 975, 976, 977, 978, 979, 980, 981, 982, 983, 984, 985, 986, 987, 988, 989, 990, 991, 992, 993, 994, 995, 996, 997, 998, 999, 1000

MAIN CONTRACTOR :
Gammon

STRUCTURAL ENGINEER :
ARUP

FACADE CONSULTANT:
MEINHARDT

NOTE :
 1. ALL DIMENSIONS ARE IN mm.
 2. ALL ELEVATIONS ARE VIEWED FROM OUTSIDE.
 3. ALL DIMENSIONS TO BE VERIFIED ON SITE BEFORE FABRICATION.

LEGEND :
 x1 --- DETAIL MARK NO.
 x001 --- REFER SHEET NO.

1. F.F.L. --- FINISHED FLOOR LEVEL
 2. S.F.L. --- STRUCTURAL FLOOR LEVEL
 3. (R) --- REVERSED DETAIL
 4. ▲ --- FIXING LOCATION
 5. △ --- FIXING LUG LOCATION
 6. GLASS LEGEND
 GL01 --- 8mm+12mm AIR GAP+10mm THK. I.G.U.
 GL01a --- 8mm+12mm AIR GAP+10mm THK. I.G.U.
 GL03 --- 6mm+12mm AIR GAP+6mm THK. I.G.U.
 GL04 --- 10mm THK. TEMPERED GLASS (PROTECTIVE BARRIER)
 GL05 --- 6mm+12mm AIR GAP+8mm THK. I.G.U.

B	05/03/2021	REVISION SUBJECT TO ARCH.COMMENT	Ivan
A	09/12/2020	REVISION SUBJECT TO ARCH.COMMENT	Ivan
NO.	DATE	REVISION	BY

JOB NO. : J-852
 PROJECT : PROPOSED RESIDENTIAL DEVELOPMENT AT 139 - 147 ARGYLE STREET, NKIL 6005, 6035 R.P., 6036 R.P., 6037 R.P. & 6038 R.P.
 TITLE : SCHEDULE FOR Plenum Box AT TOWER 2 (23F)

DATE : 05-Dec-19 SCALE : 1:40
 DRAWN BY : MN CHECKED BY : DW

美特鋁質有限公司
MIDI ALUMINIUM FABRICATOR LTD.
 Units 6-8, Sunray Industrial Centre, 1/F
 610 Cha Kwo Ling Road, Kowloon
 Tel:23489211-4 Fax:(852)2727666

DWG NO. : J852-SD-PB-4213 REV. : B

ELEVATION

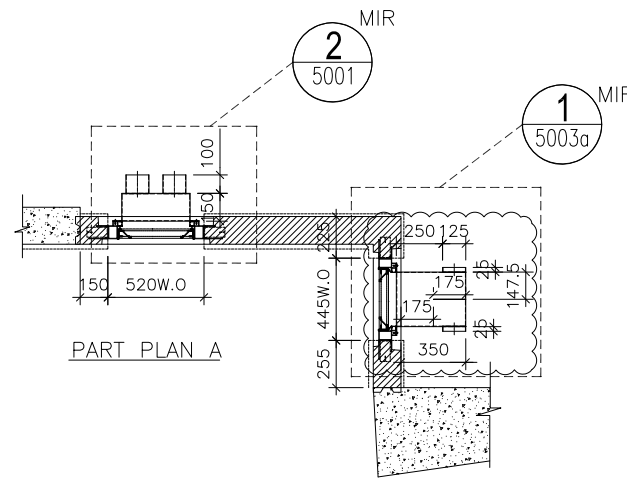
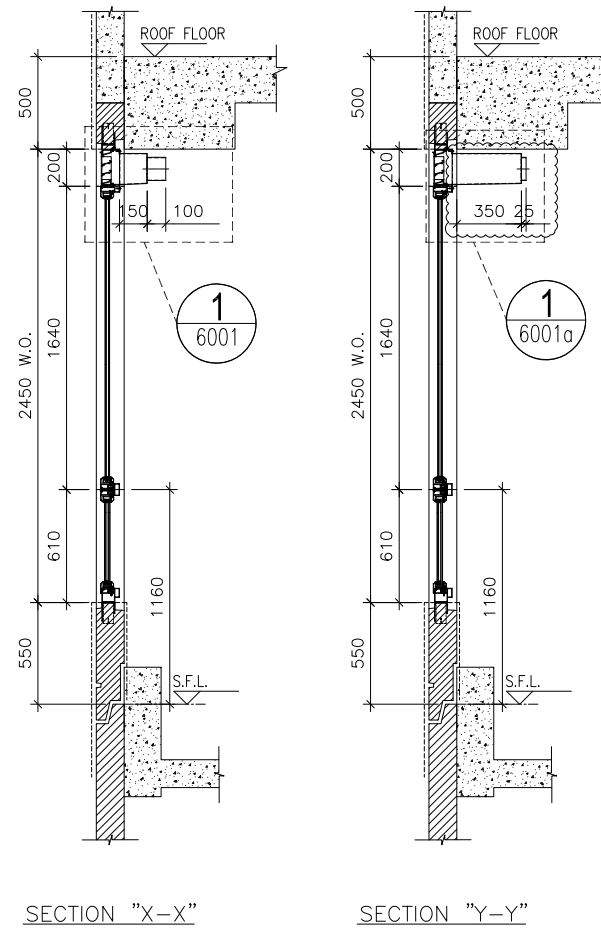
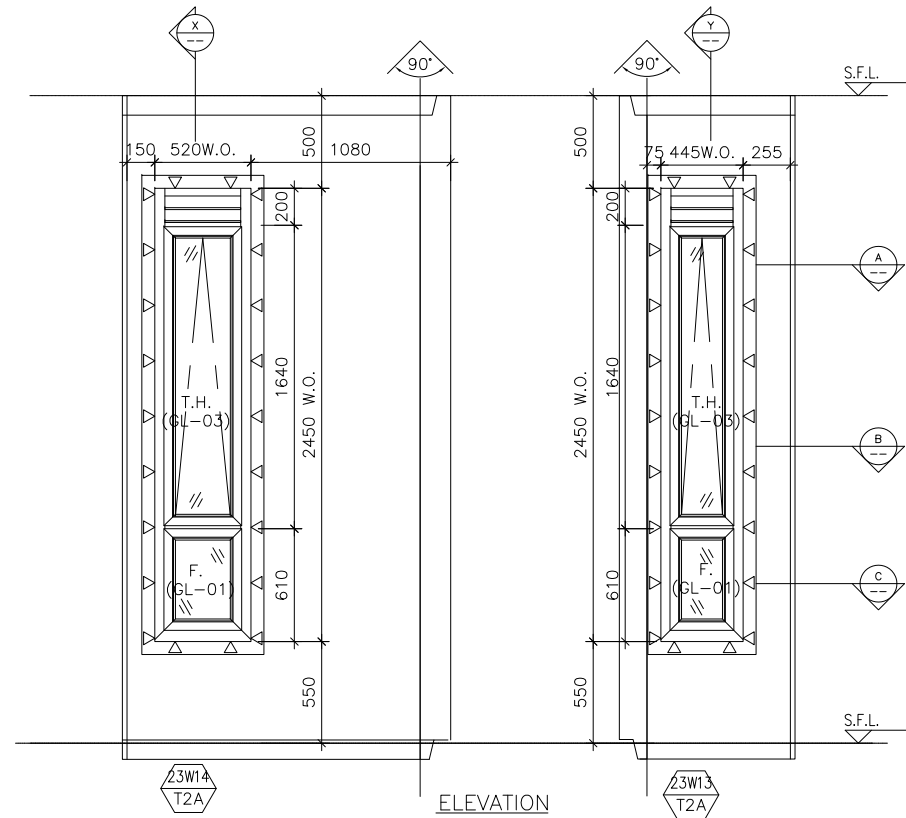

B.D. REF :

CLIENT :

ARCHITECT :
AGC DESIGN LTD
 101, 102, 103, 104, 105, 106, 107, 108, 109, 110, 111, 112, 113, 114, 115, 116, 117, 118, 119, 120, 121, 122, 123, 124, 125, 126, 127, 128, 129, 130, 131, 132, 133, 134, 135, 136, 137, 138, 139, 140, 141, 142, 143, 144, 145, 146, 147, 148, 149, 150, 151, 152, 153, 154, 155, 156, 157, 158, 159, 160, 161, 162, 163, 164, 165, 166, 167, 168, 169, 170, 171, 172, 173, 174, 175, 176, 177, 178, 179, 180, 181, 182, 183, 184, 185, 186, 187, 188, 189, 190, 191, 192, 193, 194, 195, 196, 197, 198, 199, 200, 201, 202, 203, 204, 205, 206, 207, 208, 209, 210, 211, 212, 213, 214, 215, 216, 217, 218, 219, 220, 221, 222, 223, 224, 225, 226, 227, 228, 229, 230, 231, 232, 233, 234, 235, 236, 237, 238, 239, 240, 241, 242, 243, 244, 245, 246, 247, 248, 249, 250, 251, 252, 253, 254, 255, 256, 257, 258, 259, 260, 261, 262, 263, 264, 265, 266, 267, 268, 269, 270, 271, 272, 273, 274, 275, 276, 277, 278, 279, 280, 281, 282, 283, 284, 285, 286, 287, 288, 289, 290, 291, 292, 293, 294, 295, 296, 297, 298, 299, 300, 301, 302, 303, 304, 305, 306, 307, 308, 309, 310, 311, 312, 313, 314, 315, 316, 317, 318, 319, 320, 321, 322, 323, 324, 325, 326, 327, 328, 329, 330, 331, 332, 333, 334, 335, 336, 337, 338, 339, 340, 341, 342, 343, 344, 345, 346, 347, 348, 349, 350, 351, 352, 353, 354, 355, 356, 357, 358, 359, 360, 361, 362, 363, 364, 365, 366, 367, 368, 369, 370, 371, 372, 373, 374, 375, 376, 377, 378, 379, 380, 381, 382, 383, 384, 385, 386, 387, 388, 389, 390, 391, 392, 393, 394, 395, 396, 397, 398, 399, 400, 401, 402, 403, 404, 405, 406, 407, 408, 409, 410, 411, 412, 413, 414, 415, 416, 417, 418, 419, 420, 421, 422, 423, 424, 425, 426, 427, 428, 429, 430, 431, 432, 433, 434, 435, 436, 437, 438, 439, 440, 441, 442, 443, 444, 445, 446, 447, 448, 449, 450, 451, 452, 453, 454, 455, 456, 457, 458, 459, 460, 461, 462, 463, 464, 465, 466, 467, 468, 469, 470, 471, 472, 473, 474, 475, 476, 477, 478, 479, 480, 481, 482, 483, 484, 485, 486, 487, 488, 489, 490, 491, 492, 493, 494, 495, 496, 497, 498, 499, 500, 501, 502, 503, 504, 505, 506, 507, 508, 509, 510, 511, 512, 513, 514, 515, 516, 517, 518, 519, 520, 521, 522, 523, 524, 525, 526, 527, 528, 529, 530, 531, 532, 533, 534, 535, 536, 537, 538, 539, 540, 541, 542, 543, 544, 545, 546, 547, 548, 549, 550, 551, 552, 553, 554, 555, 556, 557, 558, 559, 560, 561, 562, 563, 564, 565, 566, 567, 568, 569, 570, 571, 572, 573, 574, 575, 576, 577, 578, 579, 580, 581, 582, 583, 584, 585, 586, 587, 588, 589, 590, 591, 592, 593, 594, 595, 596, 597, 598, 599, 600, 601, 602, 603, 604, 605, 606, 607, 608, 609, 610, 611, 612, 613, 614, 615, 616, 617, 618, 619, 620, 621, 622, 623, 624, 625, 626, 627, 628, 629, 630, 631, 632, 633, 634, 635, 636, 637, 638, 639, 640, 641, 642, 643, 644, 645, 646, 647, 648, 649, 650, 651, 652, 653, 654, 655, 656, 657, 658, 659, 660, 661, 662, 663, 664, 665, 666, 667, 668, 669, 670, 671, 672, 673, 674, 675, 676, 677, 678, 679, 680, 681, 682, 683, 684, 685, 686, 687, 688, 689, 690, 691, 692, 693, 694, 695, 696, 697, 698, 699, 700, 701, 702, 703, 704, 705, 706, 707, 708, 709, 710, 711, 712, 713, 714, 715, 716, 717, 718, 719, 720, 721, 722, 723, 724, 725, 726, 727, 728, 729, 730, 731, 732, 733, 734, 735, 736, 737, 738, 739, 740, 741, 742, 743, 744, 745, 746, 747, 748, 749, 750, 751, 752, 753, 754, 755, 756, 757, 758, 759, 760, 761, 762, 763, 764, 765, 766, 767, 768, 769, 770, 771, 772, 773, 774, 775, 776, 777, 778, 779, 780, 781, 782, 783, 784, 785, 786, 787, 788, 789, 790, 791, 792, 793, 794, 795, 796, 797, 798, 799, 800, 801, 802, 803, 804, 805, 806, 807, 808, 809, 810, 811, 812, 813, 814, 815, 816, 817, 818, 819, 820, 821, 822, 823, 824, 825, 826, 827, 828, 829, 830, 831, 832, 833, 834, 835, 836, 837, 838, 839, 840, 841, 842, 843, 844, 845, 846, 847, 848, 849, 850, 851, 852, 853, 854, 855, 856, 857, 858, 859, 860, 861, 862, 863, 864, 865, 866, 867, 868, 869, 870, 871, 872, 873, 874, 875, 876, 877, 878, 879, 880, 881, 882, 883, 884, 885, 886, 887, 888, 889, 890, 891, 892, 893, 894, 895, 896, 897, 898, 899, 900, 901, 902, 903, 904, 905, 906, 907, 908, 909, 910, 911, 912, 913, 914, 915, 916, 917, 918, 919, 920, 921, 922, 923, 924, 925, 926, 927, 928, 929, 930, 931, 932, 933, 934, 935, 936, 937, 938, 939, 940, 941, 942, 943, 944, 945, 946, 947, 948, 949, 950, 951, 952, 953, 954, 955, 956, 957, 958, 959, 960, 961, 962, 963, 964, 965, 966, 967, 968, 969, 970, 971, 972, 973, 974, 975, 976, 977, 978, 979, 980, 981, 982, 983, 984, 985, 986, 987, 988, 989, 990, 991, 992, 993, 994, 995, 996, 997, 998, 999, 1000

MAIN CONTRACTOR :
Gammon

STRUCTURAL ENGINEER :
ARUP

FACADE CONSULTANT:
MEINHARDT

NOTE :
 1. ALL DIMENSIONS ARE IN mm.
 2. ALL ELEVATIONS ARE VIEWED FROM OUTSIDE.
 3. ALL DIMENSIONS TO BE VERIFIED ON SITE BEFORE FABRICATION.

LEGEND :
 (X1) — DETAIL MARK NO.
 (X001) — REFER SHEET NO.
 1. F.F.L. -- FINISHED FLOOR LEVEL
 2. S.F.L. -- STRUCTURAL FLOOR LEVEL
 3. (R) -- REVERSED DETAIL

B	22/03/2021	REVISION SUBJECT TO ARCH.COMMENT	Ivan
A	07/11/2020	REVISION SUBJECT TO ARCH.COMMENT	Ivan
NO.	DATE	REVISION	BY

JOB NO. : J-852
 PROJECT : PROPOSED RESIDENTIAL DEVELOPMENT AT 139 - 147 ARGYLE STREET, NKIL 6005, 6035 R.P., 6036 R.P., 6037 R.P. & 6038 R.P.

TITLE : SCHEDULE FOR Plenum Box AT TOWER 2 (23F)

DATE : 05-Dec-19 SCALE : 1:40
 DRAWN BY : MN CHECKED BY : DW

美特鋁質有限公司
MIDI ALUMINIUM FABRICATOR LTD.
 Units 6-8, Sunray Industrial Centre, 1/F
 610 Cha Kwo Ling Road, Kowloon
 Tel:23489211-4 Fax:(852)2727666

WINDOW MARK	23W14 / 23W13 T2A
LOCATION	23/F E.N.B.3 & E.N.B.4 AT TOWER 2 FLAT A
SECTION	70mm ALUM. SECTION
GLAZING	GL-01, GL-03
QUANTITY	1
REMARKS	FACADE (PF-36)

DWG NO. : J852-SD-PB-4214 REV. : B

ELEVATION

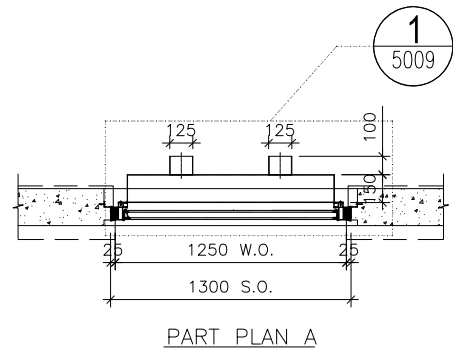
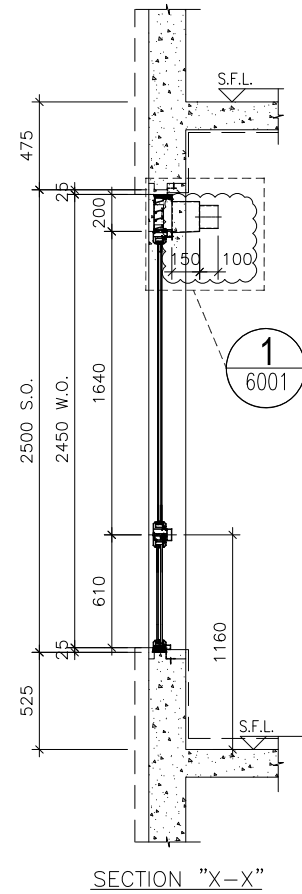
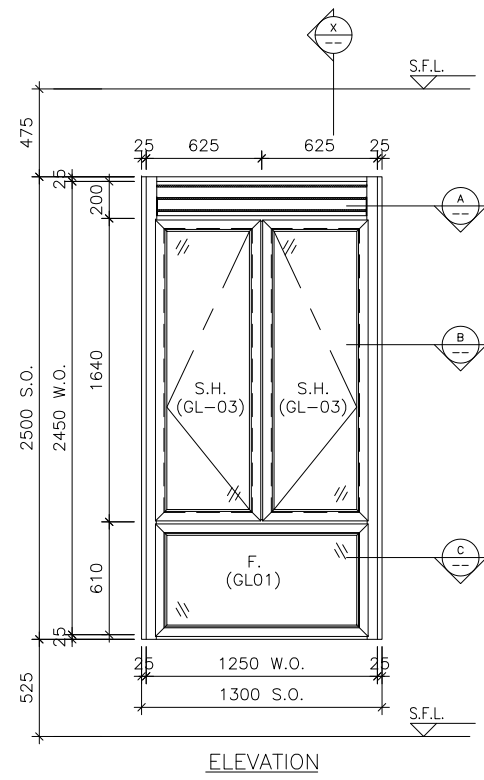

WINDOW MARK	
LOCATION	23/F BATH AT TOWER 2 FLAT A
SECTION	70mm ALUM. SECTION
GLAZING	GL-01, GL-03
QUANTITY	1
REMARKS	

B.D. REF :

CLIENT :

ARCHITECT :
AGC DESIGN LTD
 101, 102, 103, 104, 105, 106, 107, 108, 109, 110, 111, 112, 113, 114, 115, 116, 117, 118, 119, 120, 121, 122, 123, 124, 125, 126, 127, 128, 129, 130, 131, 132, 133, 134, 135, 136, 137, 138, 139, 140, 141, 142, 143, 144, 145, 146, 147, 148, 149, 150, 151, 152, 153, 154, 155, 156, 157, 158, 159, 160, 161, 162, 163, 164, 165, 166, 167, 168, 169, 170, 171, 172, 173, 174, 175, 176, 177, 178, 179, 180, 181, 182, 183, 184, 185, 186, 187, 188, 189, 190, 191, 192, 193, 194, 195, 196, 197, 198, 199, 200, 201, 202, 203, 204, 205, 206, 207, 208, 209, 210, 211, 212, 213, 214, 215, 216, 217, 218, 219, 220, 221, 222, 223, 224, 225, 226, 227, 228, 229, 230, 231, 232, 233, 234, 235, 236, 237, 238, 239, 240, 241, 242, 243, 244, 245, 246, 247, 248, 249, 250, 251, 252, 253, 254, 255, 256, 257, 258, 259, 260, 261, 262, 263, 264, 265, 266, 267, 268, 269, 270, 271, 272, 273, 274, 275, 276, 277, 278, 279, 280, 281, 282, 283, 284, 285, 286, 287, 288, 289, 290, 291, 292, 293, 294, 295, 296, 297, 298, 299, 300, 301, 302, 303, 304, 305, 306, 307, 308, 309, 310, 311, 312, 313, 314, 315, 316, 317, 318, 319, 320, 321, 322, 323, 324, 325, 326, 327, 328, 329, 330, 331, 332, 333, 334, 335, 336, 337, 338, 339, 340, 341, 342, 343, 344, 345, 346, 347, 348, 349, 350, 351, 352, 353, 354, 355, 356, 357, 358, 359, 360, 361, 362, 363, 364, 365, 366, 367, 368, 369, 370, 371, 372, 373, 374, 375, 376, 377, 378, 379, 380, 381, 382, 383, 384, 385, 386, 387, 388, 389, 390, 391, 392, 393, 394, 395, 396, 397, 398, 399, 400, 401, 402, 403, 404, 405, 406, 407, 408, 409, 410, 411, 412, 413, 414, 415, 416, 417, 418, 419, 420, 421, 422, 423, 424, 425, 426, 427, 428, 429, 430, 431, 432, 433, 434, 435, 436, 437, 438, 439, 440, 441, 442, 443, 444, 445, 446, 447, 448, 449, 450, 451, 452, 453, 454, 455, 456, 457, 458, 459, 460, 461, 462, 463, 464, 465, 466, 467, 468, 469, 470, 471, 472, 473, 474, 475, 476, 477, 478, 479, 480, 481, 482, 483, 484, 485, 486, 487, 488, 489, 490, 491, 492, 493, 494, 495, 496, 497, 498, 499, 500, 501, 502, 503, 504, 505, 506, 507, 508, 509, 510, 511, 512, 513, 514, 515, 516, 517, 518, 519, 520, 521, 522, 523, 524, 525, 526, 527, 528, 529, 530, 531, 532, 533, 534, 535, 536, 537, 538, 539, 540, 541, 542, 543, 544, 545, 546, 547, 548, 549, 550, 551, 552, 553, 554, 555, 556, 557, 558, 559, 560, 561, 562, 563, 564, 565, 566, 567, 568, 569, 570, 571, 572, 573, 574, 575, 576, 577, 578, 579, 580, 581, 582, 583, 584, 585, 586, 587, 588, 589, 590, 591, 592, 593, 594, 595, 596, 597, 598, 599, 600, 601, 602, 603, 604, 605, 606, 607, 608, 609, 610, 611, 612, 613, 614, 615, 616, 617, 618, 619, 620, 621, 622, 623, 624, 625, 626, 627, 628, 629, 630, 631, 632, 633, 634, 635, 636, 637, 638, 639, 640, 641, 642, 643, 644, 645, 646, 647, 648, 649, 650, 651, 652, 653, 654, 655, 656, 657, 658, 659, 660, 661, 662, 663, 664, 665, 666, 667, 668, 669, 670, 671, 672, 673, 674, 675, 676, 677, 678, 679, 680, 681, 682, 683, 684, 685, 686, 687, 688, 689, 690, 691, 692, 693, 694, 695, 696, 697, 698, 699, 700, 701, 702, 703, 704, 705, 706, 707, 708, 709, 710, 711, 712, 713, 714, 715, 716, 717, 718, 719, 720, 721, 722, 723, 724, 725, 726, 727, 728, 729, 730, 731, 732, 733, 734, 735, 736, 737, 738, 739, 740, 741, 742, 743, 744, 745, 746, 747, 748, 749, 750, 751, 752, 753, 754, 755, 756, 757, 758, 759, 760, 761, 762, 763, 764, 765, 766, 767, 768, 769, 770, 771, 772, 773, 774, 775, 776, 777, 778, 779, 780, 781, 782, 783, 784, 785, 786, 787, 788, 789, 790, 791, 792, 793, 794, 795, 796, 797, 798, 799, 800, 801, 802, 803, 804, 805, 806, 807, 808, 809, 810, 811, 812, 813, 814, 815, 816, 817, 818, 819, 820, 821, 822, 823, 824, 825, 826, 827, 828, 829, 830, 831, 832, 833, 834, 835, 836, 837, 838, 839, 840, 841, 842, 843, 844, 845, 846, 847, 848, 849, 850, 851, 852, 853, 854, 855, 856, 857, 858, 859, 860, 861, 862, 863, 864, 865, 866, 867, 868, 869, 870, 871, 872, 873, 874, 875, 876, 877, 878, 879, 880, 881, 882, 883, 884, 885, 886, 887, 888, 889, 890, 891, 892, 893, 894, 895, 896, 897, 898, 899, 900, 901, 902, 903, 904, 905, 906, 907, 908, 909, 910, 911, 912, 913, 914, 915, 916, 917, 918, 919, 920, 921, 922, 923, 924, 925, 926, 927, 928, 929, 930, 931, 932, 933, 934, 935, 936, 937, 938, 939, 940, 941, 942, 943, 944, 945, 946, 947, 948, 949, 950, 951, 952, 953, 954, 955, 956, 957, 958, 959, 960, 961, 962, 963, 964, 965, 966, 967, 968, 969, 970, 971, 972, 973, 974, 975, 976, 977, 978, 979, 980, 981, 982, 983, 984, 985, 986, 987, 988, 989, 990, 991, 992, 993, 994, 995, 996, 997, 998, 999, 1000

MAIN CONTRACTOR :
Gammon

STRUCTURAL ENGINEER :
ARUP

FACADE CONSULTANT:
MEINHARDT

NOTE :
 1. ALL DIMENSIONS ARE IN mm.
 2. ALL ELEVATIONS ARE VIEWED FROM OUTSIDE.
 3. ALL DIMENSIONS TO BE VERIFIED ON SITE BEFORE FABRICATION.

LEGEND :
 (X1) --- DETAIL MARK NO.
 (X001) --- REFER SHEET NO.
 1. F.F.L. --- FINISHED FLOOR LEVEL
 2. S.F.L. --- STRUCTURAL FLOOR LEVEL
 3. (R) --- REVERSED DETAIL

NO.	DATE	REVISION	BY
A	09/12/2020	REVISION SUBJECT TO ARCH.COMMENT	Ivan

JOB NO. : J-852
 PROJECT : PROPOSED RESIDENTIAL DEVELOPMENT AT 139 - 147 ARGYLE STREET, NKIL 6005, 6035 R.P., 6036 R.P., 6037 R.P. & 6038 R.P.

TITLE : SCHEDULE FOR Plenum Box AT TOWER 2 (23F)

DATE : 05-FEB-20 SCALE : 1:100
 DRAWN BY : MN CHECKED BY : DW

美特鋁質有限公司
MIDI ALUMINIUM FABRICATOR LTD.
 Units 6-8, Sunray Industrial Centre, 1/F
 610 Cha Kwo Ling Road, Kowloon
 Tel:23489211-4 Fax:(852)27727666
 DWG NO. : J852-SD-PB-4215 REV. : A

ELEVATION

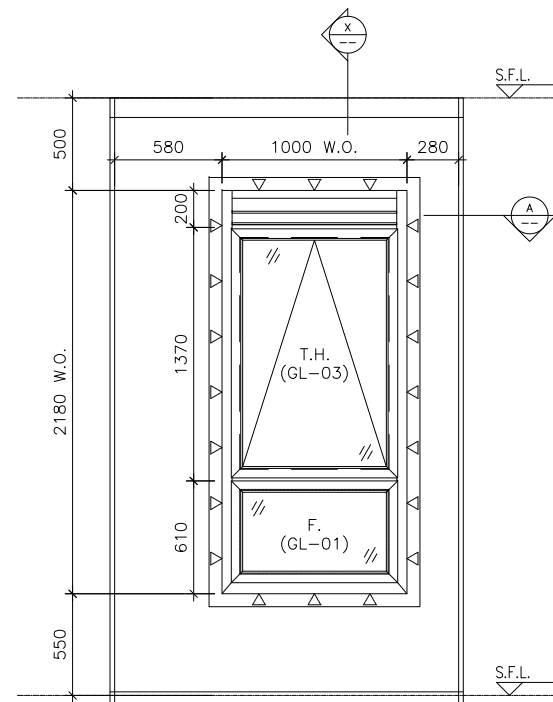

ELEVATION(FOR 1F-20F)

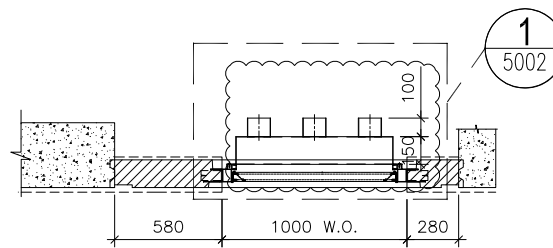

PART PLAN A

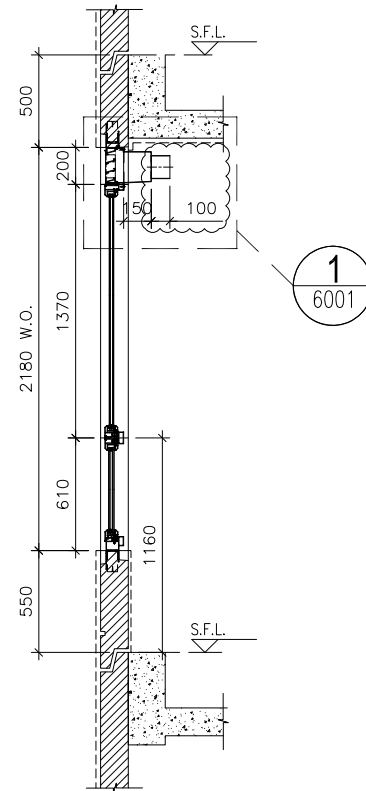

SECTION "X-X"(FOR 1F-20F)

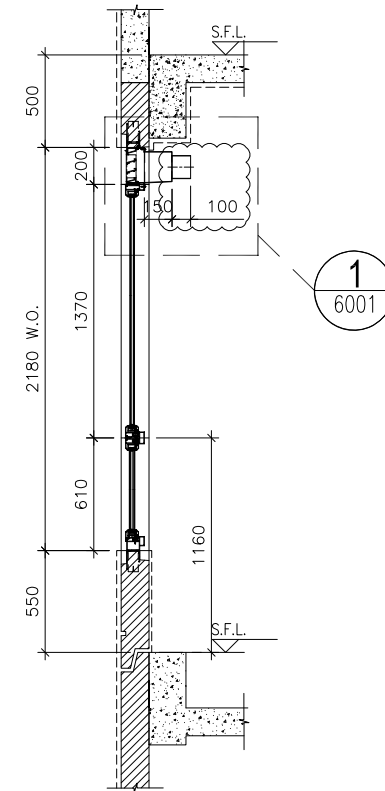

SECTION "X-X"(FOR 21F)

B.D. REF :

CLIENT :

ARCHITECT :
AGC DESIGN LTD
 101, 102, 103, 104, 105, 106, 107, 108, 109, 110, 111, 112, 113, 114, 115, 116, 117, 118, 119, 120, 121, 122, 123, 124, 125, 126, 127, 128, 129, 130, 131, 132, 133, 134, 135, 136, 137, 138, 139, 140, 141, 142, 143, 144, 145, 146, 147, 148, 149, 150, 151, 152, 153, 154, 155, 156, 157, 158, 159, 160, 161, 162, 163, 164, 165, 166, 167, 168, 169, 170, 171, 172, 173, 174, 175, 176, 177, 178, 179, 180, 181, 182, 183, 184, 185, 186, 187, 188, 189, 190, 191, 192, 193, 194, 195, 196, 197, 198, 199, 200, 201, 202, 203, 204, 205, 206, 207, 208, 209, 210, 211, 212, 213, 214, 215, 216, 217, 218, 219, 220, 221, 222, 223, 224, 225, 226, 227, 228, 229, 230, 231, 232, 233, 234, 235, 236, 237, 238, 239, 240, 241, 242, 243, 244, 245, 246, 247, 248, 249, 250, 251, 252, 253, 254, 255, 256, 257, 258, 259, 260, 261, 262, 263, 264, 265, 266, 267, 268, 269, 270, 271, 272, 273, 274, 275, 276, 277, 278, 279, 280, 281, 282, 283, 284, 285, 286, 287, 288, 289, 290, 291, 292, 293, 294, 295, 296, 297, 298, 299, 300, 301, 302, 303, 304, 305, 306, 307, 308, 309, 310, 311, 312, 313, 314, 315, 316, 317, 318, 319, 320, 321, 322, 323, 324, 325, 326, 327, 328, 329, 330, 331, 332, 333, 334, 335, 336, 337, 338, 339, 340, 341, 342, 343, 344, 345, 346, 347, 348, 349, 350, 351, 352, 353, 354, 355, 356, 357, 358, 359, 360, 361, 362, 363, 364, 365, 366, 367, 368, 369, 370, 371, 372, 373, 374, 375, 376, 377, 378, 379, 380, 381, 382, 383, 384, 385, 386, 387, 388, 389, 390, 391, 392, 393, 394, 395, 396, 397, 398, 399, 400, 401, 402, 403, 404, 405, 406, 407, 408, 409, 410, 411, 412, 413, 414, 415, 416, 417, 418, 419, 420, 421, 422, 423, 424, 425, 426, 427, 428, 429, 430, 431, 432, 433, 434, 435, 436, 437, 438, 439, 440, 441, 442, 443, 444, 445, 446, 447, 448, 449, 450, 451, 452, 453, 454, 455, 456, 457, 458, 459, 460, 461, 462, 463, 464, 465, 466, 467, 468, 469, 470, 471, 472, 473, 474, 475, 476, 477, 478, 479, 480, 481, 482, 483, 484, 485, 486, 487, 488, 489, 490, 491, 492, 493, 494, 495, 496, 497, 498, 499, 500, 501, 502, 503, 504, 505, 506, 507, 508, 509, 510, 511, 512, 513, 514, 515, 516, 517, 518, 519, 520, 521, 522, 523, 524, 525, 526, 527, 528, 529, 530, 531, 532, 533, 534, 535, 536, 537, 538, 539, 540, 541, 542, 543, 544, 545, 546, 547, 548, 549, 550, 551, 552, 553, 554, 555, 556, 557, 558, 559, 560, 561, 562, 563, 564, 565, 566, 567, 568, 569, 570, 571, 572, 573, 574, 575, 576, 577, 578, 579, 580, 581, 582, 583, 584, 585, 586, 587, 588, 589, 590, 591, 592, 593, 594, 595, 596, 597, 598, 599, 600, 601, 602, 603, 604, 605, 606, 607, 608, 609, 610, 611, 612, 613, 614, 615, 616, 617, 618, 619, 620, 621, 622, 623, 624, 625, 626, 627, 628, 629, 630, 631, 632, 633, 634, 635, 636, 637, 638, 639, 640, 641, 642, 643, 644, 645, 646, 647, 648, 649, 650, 651, 652, 653, 654, 655, 656, 657, 658, 659, 660, 661, 662, 663, 664, 665, 666, 667, 668, 669, 670, 671, 672, 673, 674, 675, 676, 677, 678, 679, 680, 681, 682, 683, 684, 685, 686, 687, 688, 689, 690, 691, 692, 693, 694, 695, 696, 697, 698, 699, 700, 701, 702, 703, 704, 705, 706, 707, 708, 709, 710, 711, 712, 713, 714, 715, 716, 717, 718, 719, 720, 721, 722, 723, 724, 725, 726, 727, 728, 729, 730, 731, 732, 733, 734, 735, 736, 737, 738, 739, 740, 741, 742, 743, 744, 745, 746, 747, 748, 749, 750, 751, 752, 753, 754, 755, 756, 757, 758, 759, 760, 761, 762, 763, 764, 765, 766, 767, 768, 769, 770, 771, 772, 773, 774, 775, 776, 777, 778, 779, 780, 781, 782, 783, 784, 785, 786, 787, 788, 789, 790, 791, 792, 793, 794, 795, 796, 797, 798, 799, 800, 801, 802, 803, 804, 805, 806, 807, 808, 809, 810, 811, 812, 813, 814, 815, 816, 817, 818, 819, 820, 821, 822, 823, 824, 825, 826, 827, 828, 829, 830, 831, 832, 833, 834, 835, 836, 837, 838, 839, 840, 841, 842, 843, 844, 845, 846, 847, 848, 849, 850, 851, 852, 853, 854, 855, 856, 857, 858, 859, 860, 861, 862, 863, 864, 865, 866, 867, 868, 869, 870, 871, 872, 873, 874, 875, 876, 877, 878, 879, 880, 881, 882, 883, 884, 885, 886, 887, 888, 889, 890, 891, 892, 893, 894, 895, 896, 897, 898, 899, 900, 901, 902, 903, 904, 905, 906, 907, 908, 909, 910, 911, 912, 913, 914, 915, 916, 917, 918, 919, 920, 921, 922, 923, 924, 925, 926, 927, 928, 929, 930, 931, 932, 933, 934, 935, 936, 937, 938, 939, 940, 941, 942, 943, 944, 945, 946, 947, 948, 949, 950, 951, 952, 953, 954, 955, 956, 957, 958, 959, 960, 961, 962, 963, 964, 965, 966, 967, 968, 969, 970, 971, 972, 973, 974, 975, 976, 977, 978, 979, 980, 981, 982, 983, 984, 985, 986, 987, 988, 989, 990, 991, 992, 993, 994, 995, 996, 997, 998, 999, 1000

MAIN CONTRACTOR :
Gammon

STRUCTURAL ENGINEER :
ARUP

FACADE CONSULTANT:
MEINHARDT

NOTE :
 1. ALL DIMENSIONS ARE IN mm.
 2. ALL ELEVATIONS ARE VIEWED FROM OUTSIDE.
 3. ALL DIMENSIONS TO BE VERIFIED ON SITE BEFORE FABRICATION.

LEGEND :
 x1 --- DETAIL MARK NO.
 x001 --- REFER SHEET NO.
 1. F.F.L. --- FINISHED FLOOR LEVEL
 2. S.F.L. --- STRUCTURAL FLOOR LEVEL
 3. (R) --- REVERSED DETAIL
 4. ▲ --- FIXING LOCATION
 5. △ --- FIXING LUG LOCATION
 6. GLASS LEGEND
 GL01 --- 8mm+12mm AIR GAP+10mm THK. I.G.U.
 GL01a --- 8mm+12mm AIR GAP+12mm THK. I.G.U.
 GL02 --- 10mm THK. TEMPERED GLASS (SPANDREL GLASS)
 GL03 --- 6mm+12mm AIR GAP+6mm THK. I.G.U.
 GL04 --- 10mm THK. TEMPERED GLASS (PROTECTIVE BARRIER)
 GL05 --- 6mm+12mm AIR GAP+8mm THK. I.G.U.

NO.	DATE	REVISION	BY
A	07/11/2020	REVISION SUBJECT TO ARCH.COMMENT	lvart

JOB NO. : J-852
 PROJECT :
 PROPOSED RESIDENTIAL DEVELOPMENT
 AT 139 - 147 ARGYLE STREET,
 NKIL 6005, 6035 R.P., 6036 R.P.,
 6037 R.P. & 6038 R.P.
 TITLE :
 SCHEDULE FOR Plenum Box
 AT TOWER 3 (1-21F)

DATE : 05-Dec-19 SCALE : 1:40
 DRAWN BY : MN CHECKED BY : DW

美特鋁質有限公司
MIDI ALUMINIUM FABRICATOR LTD.
 Units 6-8, Sunray Industrial Centre, 1/F
 610 Cha Kwo Ling Road, Kowloon
 Tel:23489211-4 Fax:(852)2727666

WINDOW MARK	W4 T3A
LOCATION	1/F-21/F M.B. AT TOWER 3 FLAT A
SECTION	70mm ALUM. SECTION
GLAZING	GL-01, GL-03
QUANTITY	18
REMARKS	FACADE (PF-13)

DWG NO. : J852-SD-PB-4301 REV. : A

ELEVATION

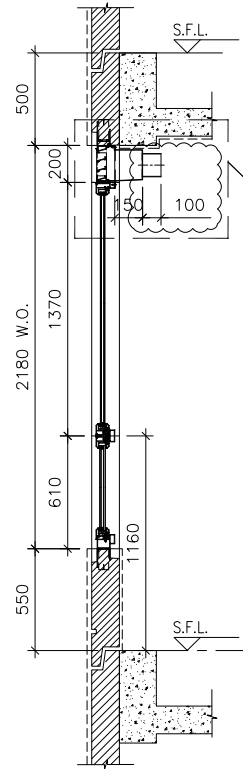
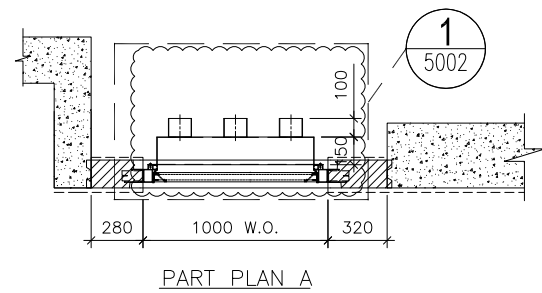
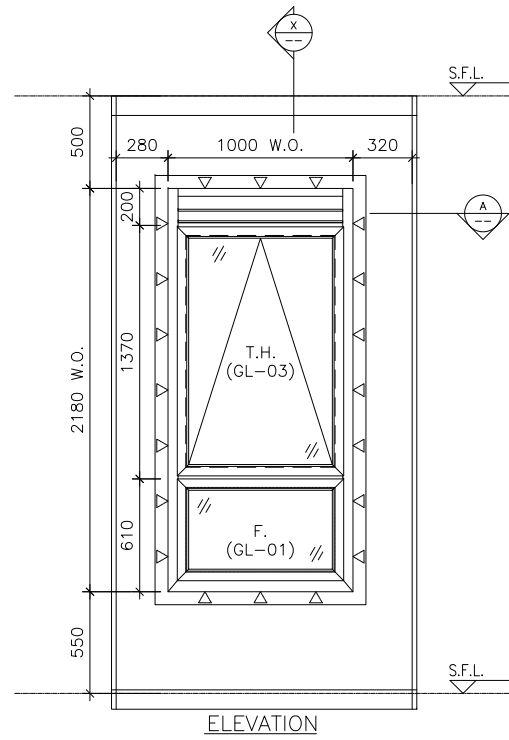

SECTION "X-X"(FOR 1F-20F)

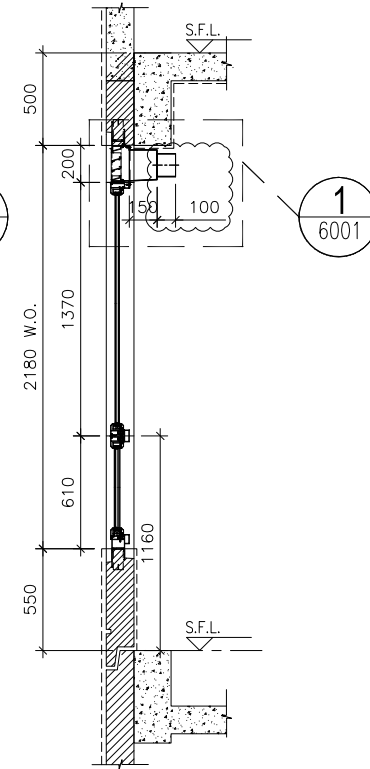

SECTION "X-X"(FOR 21F)

WINDOW MARK



LOCATION 1/F-21/F EN.B. AT TOWER 3 FLAT A

SECTION 70mm ALUM. SECTION

GLAZING GL-01, GL-03

QUANTITY 18

REMARKS FACADE (PF-14)

B.D. REF :

CLIENT :

ARCHITECT :



MAIN CONTRACTOR :



STRUCTURAL ENGINEER :



FACADE CONSULTANT:



NOTE :

1. ALL DIMENSIONS ARE IN mm.
2. ALL ELEVATIONS ARE VIEWED FROM OUTSIDE.
3. ALL DIMENSIONS TO BE VERIFIED ON SITE BEFORE FABRICATION.

LEGEND :

- x1 --- DETAIL MARK NO.
- x001 --- REFER SHEET NO.

1. F.F.L. --- FINISHED FLOOR LEVEL
2. S.F.L. --- STRUCTURAL FLOOR LEVEL
3. (R) --- REVERSED DETAIL
4. ▲ --- FIXING LOCATION
5. △ --- FIXING LUG LOCATION

6. GLASS LEGEND

- GL01 --- 8mm+12mm AIR GAP+10mm THK. I.G.U.
- GL01a --- 8mm+12mm AIR GAP+12mm THK. I.G.U.
- GL02 --- 10mm THK. TEMPERED GLASS (SPANDREL GLASS)
- GL03 --- 6mm+12mm AIR GAP+6mm THK. I.G.U.
- GL04 --- 10mm THK. TEMPERED GLASS (PROTECTIVE BARRIER)
- GL05 --- 6mm+12mm AIR GAP+8mm THK. I.G.U.

NO.	DATE	REVISION	BY
A	07/11/2020	REVISION SUBJECT TO ARCH.COMMENT	lvart

JOB NO. : J-852

PROJECT :
PROPOSED RESIDENTIAL DEVELOPMENT
AT 139 - 147 ARGYLE STREET,
NKIL 6005, 6035 R.P., 6036 R.P.,
6037 R.P. & 6038 R.P.

TITLE :
SCHEDULE FOR Plenum Box
AT TOWER 3 (1-21F)

DATE : 05-Dec-19 SCALE : 1:40

DRAWN BY : MN CHECKED BY : DW

美特鋁質有限公司
MIDI ALUMINIUM FABRICATOR LTD.
Units 6-8, Sunray Industrial Centre, 1/F
610 Cha Kwo Ling Road, Kowloon
Tel:23489211-4 Fax:(852)2727666

DWG NO. : J852-SD-PB-4302 REV. : A

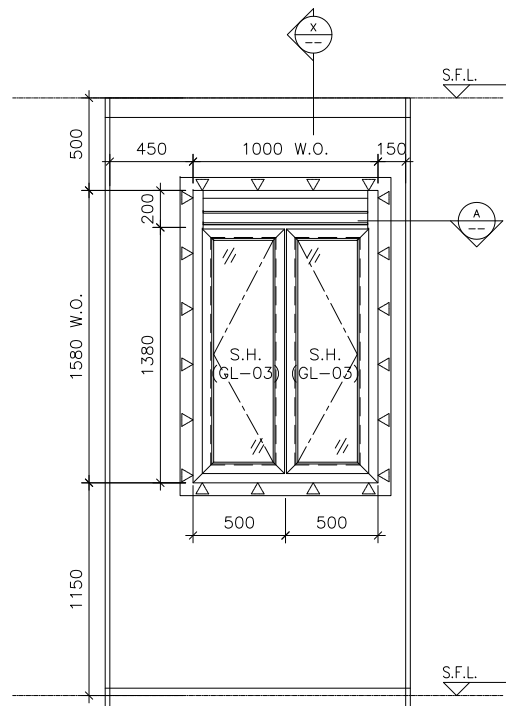

ELEVATION

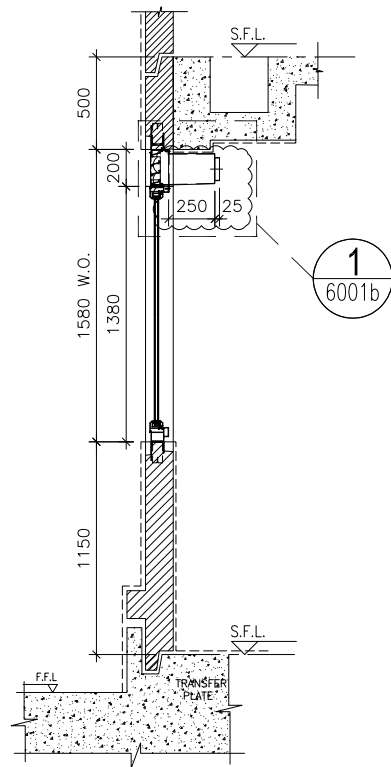

SECTION "X-X"(FOR 1F)

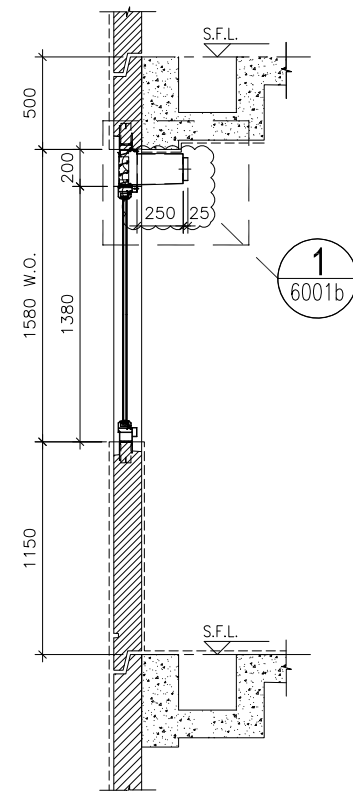

SECTION "X-X"(FOR 2F-21F)

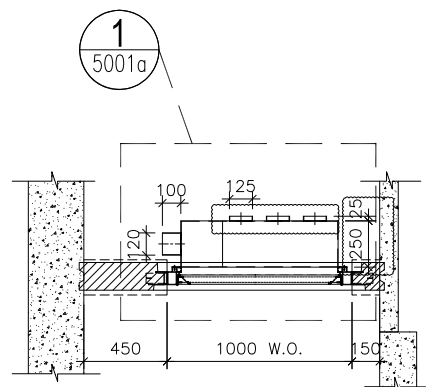

PART PLAN A

ELEVATION

WINDOW MARK



LOCATION 1/F-21/F KIT. AT TOWER 3 FLAT C

SECTION 70mm ALUM. SECTION

GLAZING GL-03

QUANTITY 18

REMARKS FACADE (PF-25)

B.D. REF :

CLIENT :

ARCHITECT :



MAIN CONTRACTOR :



STRUCTURAL ENGINEER :



FACADE CONSULTANT:



NOTE :

1. ALL DIMENSIONS ARE IN mm.
2. ALL ELEVATIONS ARE VIEWED FROM OUTSIDE.
3. ALL DIMENSIONS TO BE VERIFIED ON SITE BEFORE FABRICATION.

LEGEND :

- (x1) --- DETAIL MARK NO.
- (x001) --- REFER SHEET NO.

1. F.F.L. --- FINISHED FLOOR LEVEL
2. S.F.L. --- STRUCTURAL FLOOR LEVEL
3. (R) --- REVERSED DETAIL
4. ▲ --- FIXING LOCATION
5. △ --- FIXING LUG LOCATION

6. GLASS LEGEND
- GL01 --- 8mm+12mm AIR GAP+10mm THK. I.G.U.
 - GL01a --- 8mm+12mm AIR GAP+12mm THK. I.G.U.
 - GL02 --- 10mm THK. TEMPERED GLASS (SPANDREL GLASS)
 - GL03 --- 6mm+12mm AIR GAP+6mm THK. I.G.U.
 - GL04 --- 10mm THK. TEMPERED GLASS (PROTECTIVE BARRIER)
 - GL05 --- 6mm+12mm AIR GAP+8mm THK. I.G.U.

B	05/03/2021	REVISION SUBJECT TO ARCH.COMMENT	Ivan
A	07/11/2020	REVISION SUBJECT TO ARCH.COMMENT	Ivan
NO.	DATE	REVISED	BY

JOB NO. : J-852
 PROJECT : PROPOSED RESIDENTIAL DEVELOPMENT AT 139 - 147 ARGYLE STREET, NKIL 6005, 6035 R.P., 6036 R.P., 6037 R.P. & 6038 R.P.

TITLE : SCHEDULE FOR Plenum Box AT TOWER 3 (1-21F)

DATE : 05-Dec-19 SCALE : 1:40
 DRAWN BY : MN CHECKED BY : DW



DWG NO. : J852-SD-PB-4303 REV. : B

ELEVATION

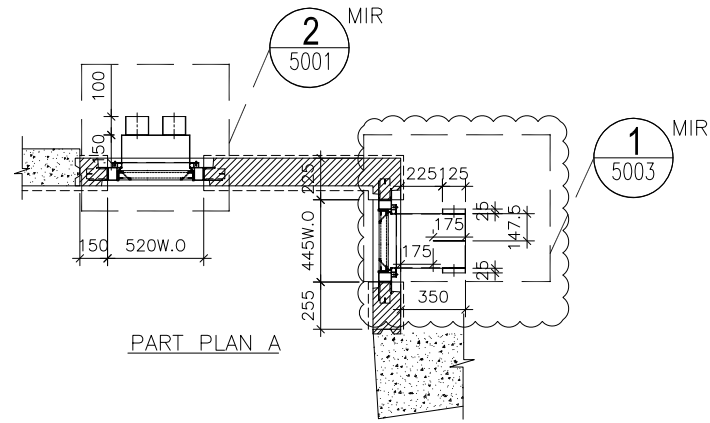
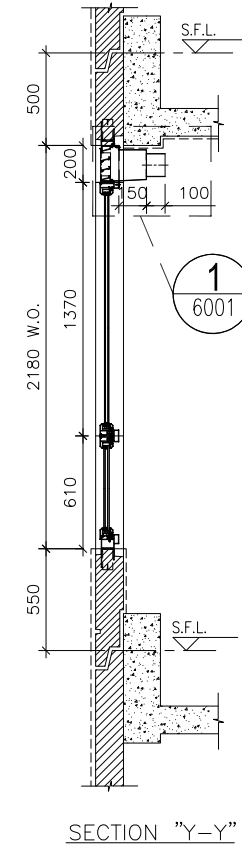
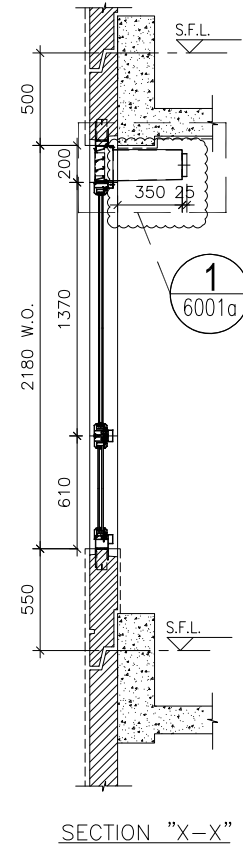
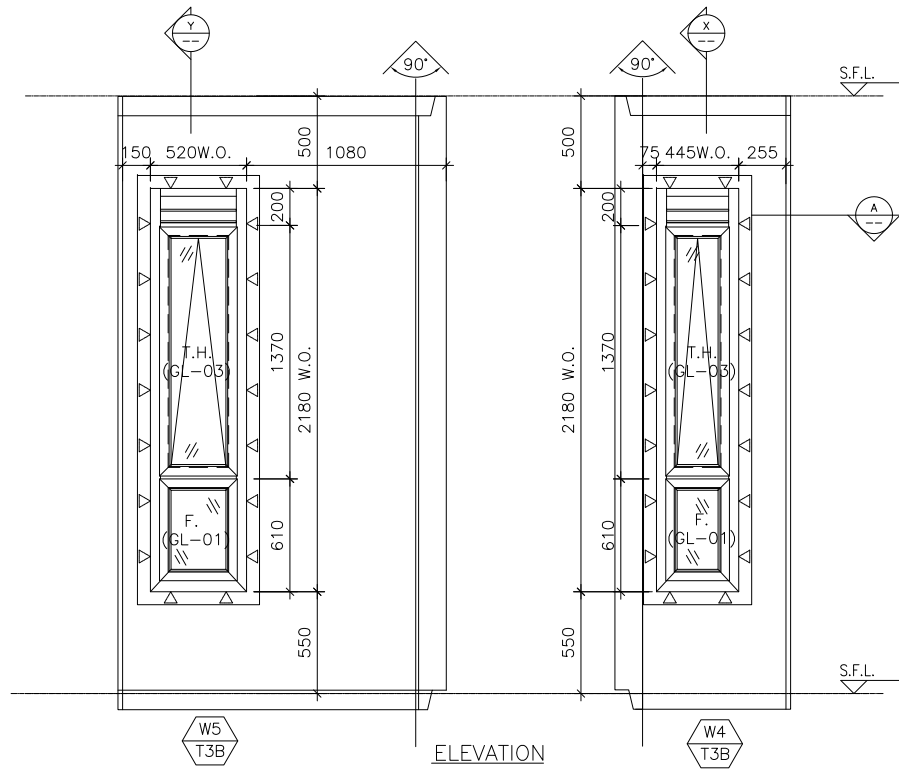

WINDOW MARK /

LOCATION 1/F-21/F M.B. & EN.B. AT TOWER 3 FLAT B

SECTION 70mm ALUM. SECTION

GLAZING GL-01, GL-03

QUANTITY 18 / 18

REMARKS FACADE (PF-34)

B.D. REF :

CLIENT :

ARCHITECT :
AGC DESIGN LTD
101, 102, 103, 104, 105, 106, 107, 108, 109, 110, 111, 112, 113, 114, 115, 116, 117, 118, 119, 120, 121, 122, 123, 124, 125, 126, 127, 128, 129, 130, 131, 132, 133, 134, 135, 136, 137, 138, 139, 140, 141, 142, 143, 144, 145, 146, 147, 148, 149, 150, 151, 152, 153, 154, 155, 156, 157, 158, 159, 160, 161, 162, 163, 164, 165, 166, 167, 168, 169, 170, 171, 172, 173, 174, 175, 176, 177, 178, 179, 180, 181, 182, 183, 184, 185, 186, 187, 188, 189, 190, 191, 192, 193, 194, 195, 196, 197, 198, 199, 200, 201, 202, 203, 204, 205, 206, 207, 208, 209, 210, 211, 212, 213, 214, 215, 216, 217, 218, 219, 220, 221, 222, 223, 224, 225, 226, 227, 228, 229, 230, 231, 232, 233, 234, 235, 236, 237, 238, 239, 240, 241, 242, 243, 244, 245, 246, 247, 248, 249, 250, 251, 252, 253, 254, 255, 256, 257, 258, 259, 260, 261, 262, 263, 264, 265, 266, 267, 268, 269, 270, 271, 272, 273, 274, 275, 276, 277, 278, 279, 280, 281, 282, 283, 284, 285, 286, 287, 288, 289, 290, 291, 292, 293, 294, 295, 296, 297, 298, 299, 300, 301, 302, 303, 304, 305, 306, 307, 308, 309, 310, 311, 312, 313, 314, 315, 316, 317, 318, 319, 320, 321, 322, 323, 324, 325, 326, 327, 328, 329, 330, 331, 332, 333, 334, 335, 336, 337, 338, 339, 340, 341, 342, 343, 344, 345, 346, 347, 348, 349, 350, 351, 352, 353, 354, 355, 356, 357, 358, 359, 360, 361, 362, 363, 364, 365, 366, 367, 368, 369, 370, 371, 372, 373, 374, 375, 376, 377, 378, 379, 380, 381, 382, 383, 384, 385, 386, 387, 388, 389, 390, 391, 392, 393, 394, 395, 396, 397, 398, 399, 400, 401, 402, 403, 404, 405, 406, 407, 408, 409, 410, 411, 412, 413, 414, 415, 416, 417, 418, 419, 420, 421, 422, 423, 424, 425, 426, 427, 428, 429, 430, 431, 432, 433, 434, 435, 436, 437, 438, 439, 440, 441, 442, 443, 444, 445, 446, 447, 448, 449, 450, 451, 452, 453, 454, 455, 456, 457, 458, 459, 460, 461, 462, 463, 464, 465, 466, 467, 468, 469, 470, 471, 472, 473, 474, 475, 476, 477, 478, 479, 480, 481, 482, 483, 484, 485, 486, 487, 488, 489, 490, 491, 492, 493, 494, 495, 496, 497, 498, 499, 500, 501, 502, 503, 504, 505, 506, 507, 508, 509, 510, 511, 512, 513, 514, 515, 516, 517, 518, 519, 520, 521, 522, 523, 524, 525, 526, 527, 528, 529, 530, 531, 532, 533, 534, 535, 536, 537, 538, 539, 540, 541, 542, 543, 544, 545, 546, 547, 548, 549, 550, 551, 552, 553, 554, 555, 556, 557, 558, 559, 560, 561, 562, 563, 564, 565, 566, 567, 568, 569, 570, 571, 572, 573, 574, 575, 576, 577, 578, 579, 580, 581, 582, 583, 584, 585, 586, 587, 588, 589, 590, 591, 592, 593, 594, 595, 596, 597, 598, 599, 600, 601, 602, 603, 604, 605, 606, 607, 608, 609, 610, 611, 612, 613, 614, 615, 616, 617, 618, 619, 620, 621, 622, 623, 624, 625, 626, 627, 628, 629, 630, 631, 632, 633, 634, 635, 636, 637, 638, 639, 640, 641, 642, 643, 644, 645, 646, 647, 648, 649, 650, 651, 652, 653, 654, 655, 656, 657, 658, 659, 660, 661, 662, 663, 664, 665, 666, 667, 668, 669, 670, 671, 672, 673, 674, 675, 676, 677, 678, 679, 680, 681, 682, 683, 684, 685, 686, 687, 688, 689, 690, 691, 692, 693, 694, 695, 696, 697, 698, 699, 700, 701, 702, 703, 704, 705, 706, 707, 708, 709, 710, 711, 712, 713, 714, 715, 716, 717, 718, 719, 720, 721, 722, 723, 724, 725, 726, 727, 728, 729, 730, 731, 732, 733, 734, 735, 736, 737, 738, 739, 740, 741, 742, 743, 744, 745, 746, 747, 748, 749, 750, 751, 752, 753, 754, 755, 756, 757, 758, 759, 760, 761, 762, 763, 764, 765, 766, 767, 768, 769, 770, 771, 772, 773, 774, 775, 776, 777, 778, 779, 780, 781, 782, 783, 784, 785, 786, 787, 788, 789, 790, 791, 792, 793, 794, 795, 796, 797, 798, 799, 800, 801, 802, 803, 804, 805, 806, 807, 808, 809, 810, 811, 812, 813, 814, 815, 816, 817, 818, 819, 820, 821, 822, 823, 824, 825, 826, 827, 828, 829, 830, 831, 832, 833, 834, 835, 836, 837, 838, 839, 840, 841, 842, 843, 844, 845, 846, 847, 848, 849, 850, 851, 852, 853, 854, 855, 856, 857, 858, 859, 860, 861, 862, 863, 864, 865, 866, 867, 868, 869, 870, 871, 872, 873, 874, 875, 876, 877, 878, 879, 880, 881, 882, 883, 884, 885, 886, 887, 888, 889, 890, 891, 892, 893, 894, 895, 896, 897, 898, 899, 900, 901, 902, 903, 904, 905, 906, 907, 908, 909, 910, 911, 912, 913, 914, 915, 916, 917, 918, 919, 920, 921, 922, 923, 924, 925, 926, 927, 928, 929, 930, 931, 932, 933, 934, 935, 936, 937, 938, 939, 940, 941, 942, 943, 944, 945, 946, 947, 948, 949, 950, 951, 952, 953, 954, 955, 956, 957, 958, 959, 960, 961, 962, 963, 964, 965, 966, 967, 968, 969, 970, 971, 972, 973, 974, 975, 976, 977, 978, 979, 980, 981, 982, 983, 984, 985, 986, 987, 988, 989, 990, 991, 992, 993, 994, 995, 996, 997, 998, 999, 1000

MAIN CONTRACTOR :
Gammon

STRUCTURAL ENGINEER :
ARUP

FACADE CONSULTANT:
MEINHARDT

NOTE :
1. ALL DIMENSIONS ARE IN mm.
2. ALL ELEVATIONS ARE VIEWED FROM OUTSIDE.
3. ALL DIMENSIONS TO BE VERIFIED ON SITE BEFORE FABRICATION.

LEGEND :
x1 -- DETAIL MARK NO.
x001 -- REFER SHEET NO.
1. F.F.L. -- FINISHED FLOOR LEVEL
2. S.F.L. -- STRUCTURAL FLOOR LEVEL
3. (R) -- REVERSED DETAIL
4. ▲ -- FIXING LOCATION
5. △ -- FIXING LUG LOCATION
6. GLASS LEGEND
GL01 -- 8mm+12mm AIR GAP+10mm THK. I.G.U.
GL01a -- 8mm+12mm AIR GAP+12mm THK. I.G.U.
GL02 -- 10mm THK. TEMPERED GLASS (SPANDREL GLASS)
GL03 -- 6mm+12mm AIR GAP+6mm THK. I.G.U.
GL04 -- 10mm THK. TEMPERED GLASS (PROTECTIVE BARRIER)
GL05 -- 6mm+12mm AIR GAP+8mm THK. I.G.U.

C	22/03/2021	REVISION SUBJECT TO ARCH.COMMENT	Ivan
B	06/01/2021	REVISION SUBJECT TO ARCH.COMMENT	Ivan
A	07/11/2020	REVISION SUBJECT TO ARCH.COMMENT	Ivan
NO.	DATE	REVISION	BY

JOB NO. : J-852
PROJECT : PROPOSED RESIDENTIAL DEVELOPMENT AT 139 - 147 ARGYLE STREET, NKIL 6005, 6035 R.P., 6036 R.P., 6037 R.P. & 6038 R.P.
TITLE : SCHEDULE FOR Plenum Box AT TOWER 3 (1-21F)

DATE : 05-Dec-19 SCALE : 1:40
DRAWN BY : MN CHECKED BY : DW

美特鋁質有限公司
MIDI ALUMINIUM FABRICATOR LTD.
Units 6-8, Sunray Industrial Centre, 1/F
610 Cha Kwo Ling Road, Kowloon
Tel:23489211-4 Fax:(852)2727666

DWG NO. : J852-SD-PB-4304 REV. : C

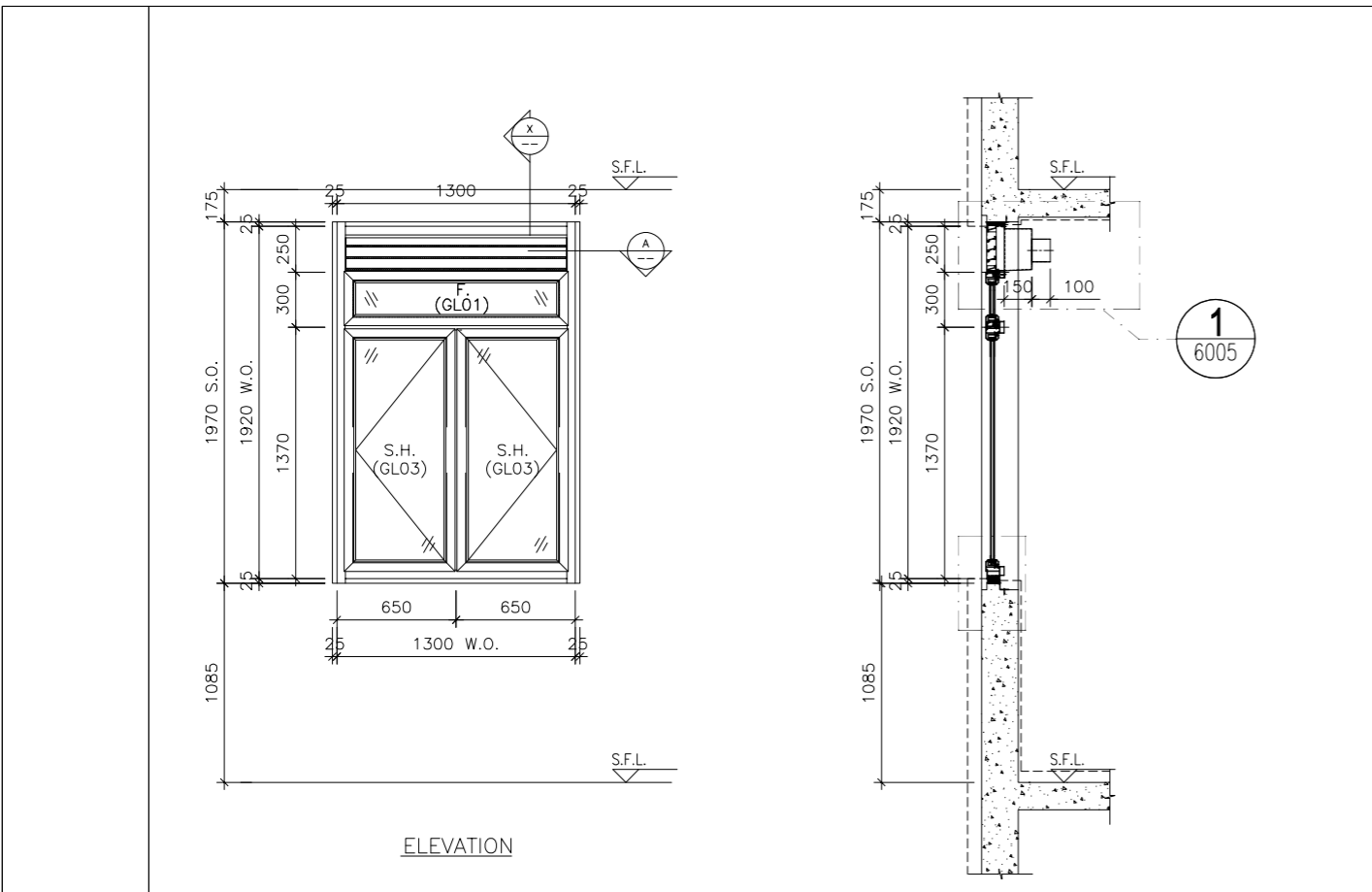

ELEVATION

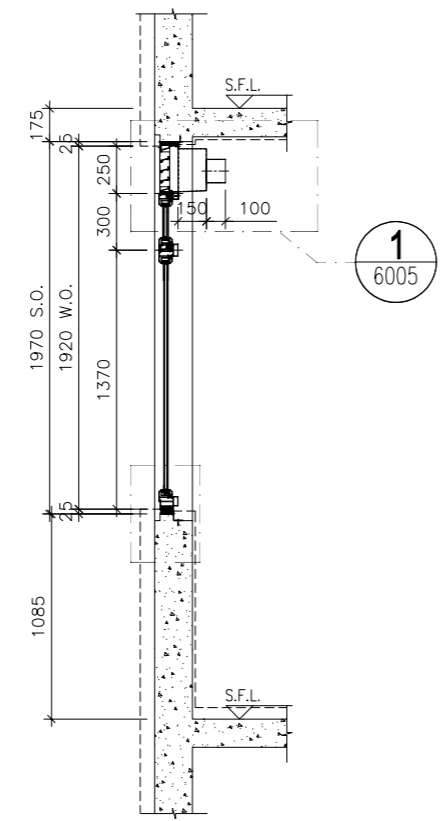

SECTION "X-X"

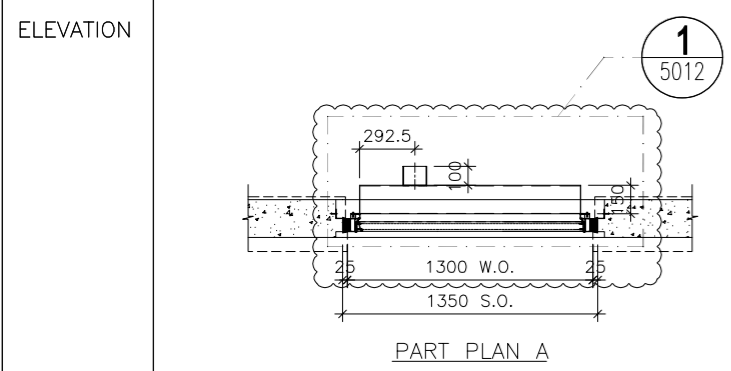

PART PLAN A

ELEVATION

WINDOW MARK	W10 T3A
LOCATION	1/F~20/F KIT. AT TOWER 3 FLAT A
SECTION	70mm ALUM. SECTION
GLAZING	GL01, GL03
QUANTITY	17
REMARKS	

B.D. REF :

CLIENT :

ARCHITECT :
AGC DESIGN LTD
 100, 14/F, Domain Place, 255 King's Road, North Point, Hong Kong
 Tel: (852)2797816, Fax: (852)2797133, Email: agc@agc.com.hk

MAIN CONTRACTOR :
Gammon

STRUCTURAL ENGINEER :
ARUP

FACADE CONSULTANT:
MEINHARDT

NOTE :
 1. ALL DIMENSIONS ARE IN mm.
 2. ALL ELEVATIONS ARE VIEWED FROM OUTSIDE.
 3. ALL DIMENSIONS TO BE VERIFIED ON SITE BEFORE FABRICATION.

LEGEND :
 X1 --- DETAIL MARK NO.
 X001 --- REFER SHEET NO.
 1. F.F.L. --- FINISHED FLOOR LEVEL
 2. S.F.L. --- STRUCTURAL FLOOR LEVEL
 3. (R) --- REVERSED DETAIL
 4. ▲ --- FIXING LOCATION
 5. △ --- FIXING LUG LOCATION
 6. GLASS LEGEND
 GL01 --- 8mm+12mm AIR GAP+10mm THK. I.G.U.
 GL01α --- 8mm+12mm AIR GAP+12mm THK. I.G.U.
 GL02 --- 10mm THK. TEMPERED GLASS (SPANDREL GLASS)
 GL03 --- 6mm+12mm AIR GAP+6mm THK. I.G.U.
 GL04 --- 10mm THK. TEMPERED GLASS (PROTECTIVE BARRIER)
 GL05 --- 6mm+12mm AIR GAP+8mm THK. I.G.U.

NO.	DATE	REVISION SUBJECT TO ARCH.COMMENT	REVISOR	BY
A	09/12/2020	REVISION SUBJECT TO ARCH.COMMENT		Ivan

JOB NO. : J-852
 PROJECT :
 PROPOSED RESIDENTIAL DEVELOPMENT
 AT 139 - 147 ARGYLE STREET,
 NKIL 6005, 6035 R.P., 6036 R.P.,
 6037 R.P. & 6038 R.P.
 TITLE :
 SCHEDULE FOR Plenum Box
 AT TOWER 3 (1-21F)

DATE : 05-FEB-20 SCALE : 1:100
 DRAWN BY : MN CHECKED BY : DW

美特鋁質有限公司
MIDI ALUMINIUM FABRICATOR LTD.
 Units 6-8, Sunray Industrial Centre, 1/F
 610 Cha Kwo Ling Road, Kowloon
 Tel:23489211-4 Fax:(852)27727666
 DWG NO. : J852-SD-PB-4305 REV. : A

B.D. REF :

CLIENT :

ARCHITECT :
AGC DESIGN LTD
AGC DESIGN LTD
 100, 1/F, D'Almeida Place, 255, King's Road, North Point, Hong Kong
 Tel: (852) 25191818, Fax: (852) 25191133, Email: agc@agcdesign.com.hk

MAIN CONTRACTOR :
Gammon

STRUCTURAL ENGINEER :
ARUP

FACADE CONSULTANT:
MEINHARDT

NOTE :
 1. ALL DIMENSIONS ARE IN mm.
 2. ALL ELEVATIONS ARE VIEWED FROM OUTSIDE.
 3. ALL DIMENSIONS TO BE VERIFIED ON SITE BEFORE FABRICATION.

LEGEND :
 X1 --- DETAIL MARK NO.
 X001 --- REFER SHEET NO.

1. F.F.L. --- FINISHED FLOOR LEVEL
 2. S.F.L. --- STRUCTURAL FLOOR LEVEL
 3. (R) --- REVERSED DETAIL
 4. ▲ --- FIXING LOCATION
 5. △ --- FIXING LUG LOCATION
 6. GLASS LEGEND
 GL01 --- 8mm+12mm AIR GAP+10mm THK. I.G.U.
 GL01α --- 8mm+12mm AIR GAP+12mm THK. I.G.U.
 GL02 --- 10mm THK. TEMPERED GLASS (SPANDREL GLASS)
 GL03 --- 6mm+12mm AIR GAP+6mm THK. I.G.U.
 GL04 --- 10mm THK. TEMPERED GLASS (PROTECTIVE BARRIER)
 GL05 --- 6mm+12mm AIR GAP+8mm THK. I.G.U.

A	07/11/2020	REVISION SUBJECT TO ARCH.COMMENT	Ivan
NO.	DATE	REVISED	BY

JOB NO. : J-852
 PROJECT :
 PROPOSED RESIDENTIAL DEVELOPMENT
 AT 139 - 147 ARGYLE STREET,
 NKIL 6005, 6035 R.P., 6036 R.P.,
 6037 R.P. & 6038 R.P.

TITLE :
 SCHEDULE FOR Plenum Box
 AT TOWER 3 (1-21F)

DATE : 05-FEB-20 SCALE : 1:100
 DRAWN BY : MN CHECKED BY : DW

美特鋁質有限公司
MIDI ALUMINIUM FABRICATOR LTD.
 Units 6-8, Sunray Industrial Centre, 1/F
 610 Cha Kwo Ling Road, Kowloon
 Tel:23489211-4 Fax:(852)2772666
 DWG NO. : J852-SD-PB-4306 REV. : A

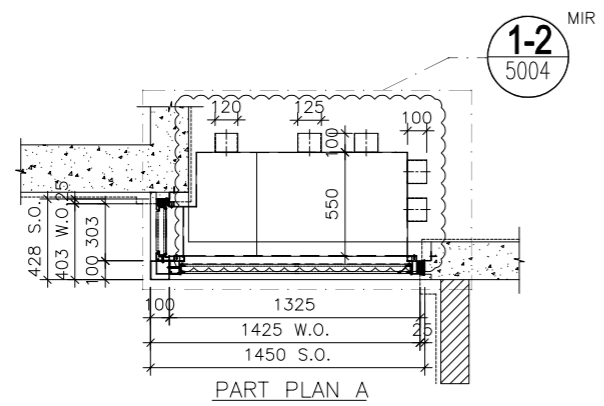
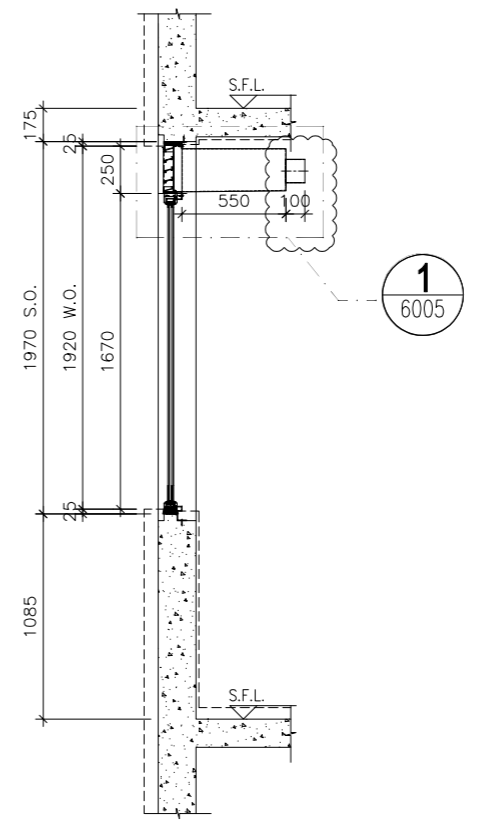
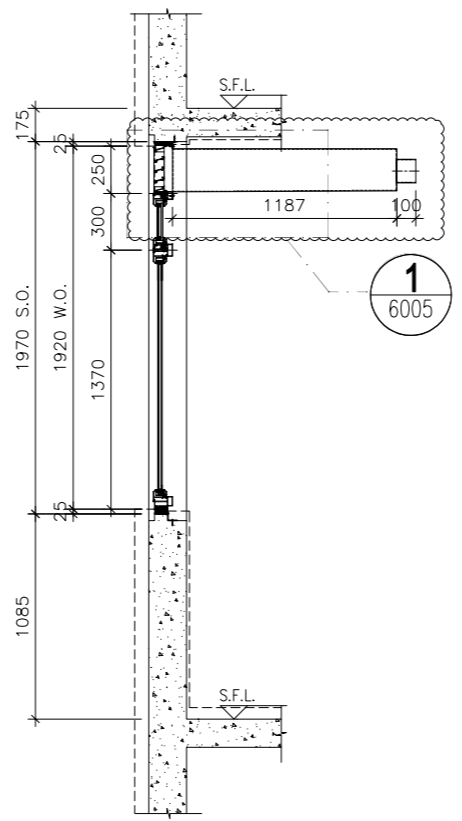
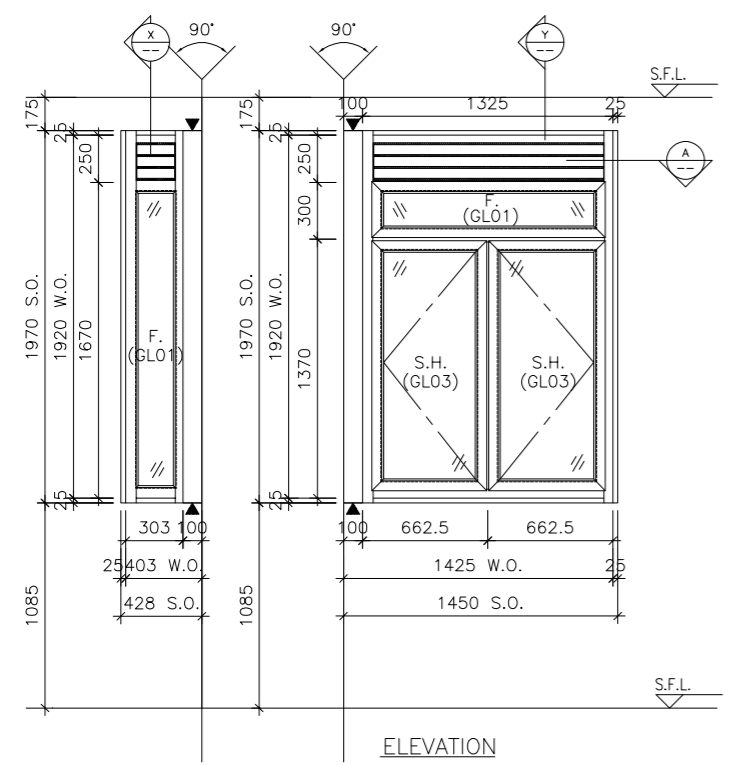

ELEVATION

SECTION "X-X"

SECTION "Y-Y"

ELEVATION

PART PLAN A

WINDOW MARK	W8 T3B
LOCATION	1/F~21/F KIT. AT TOWER 3 FLAT B
SECTION	50mm ALUM. SECTION
GLAZING	GL01, GL03
QUANTITY	18
REMARKS	

ELEVATION

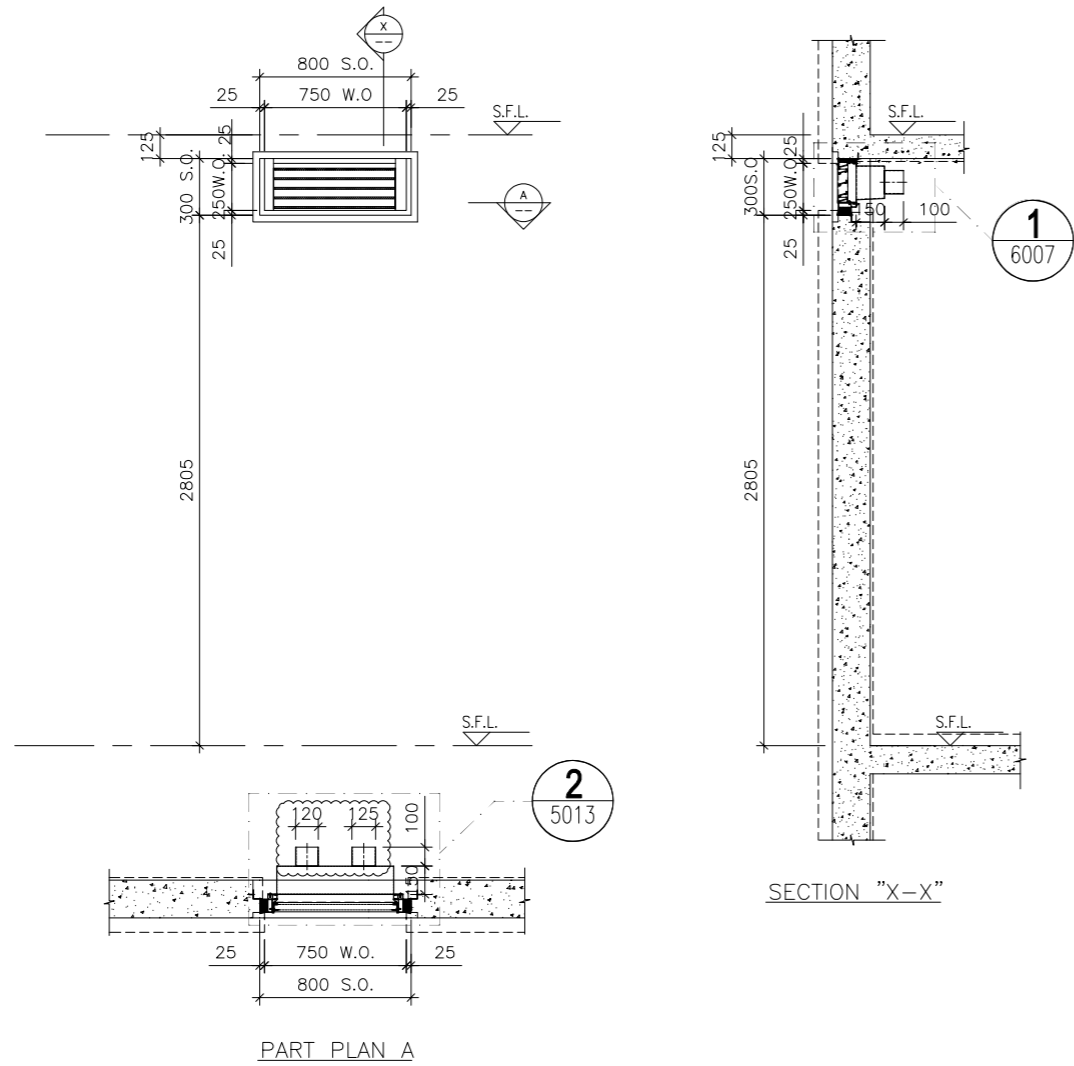

WINDOW MARK	W9 T3A
LOCATION	1/F~20/F Corridor AT TOWER 3 FLAT C
SECTION	50mm ALUM. SECTION
GLAZING	
QUANTITY	17
REMARKS	

B.D. REF :

CLIENT :

ARCHITECT :
AGC DESIGN LTD
 1001, 14/F, Ocean Plaza, 225, King's Road, North Point, Hong Kong
 Tel: (852)2779788, Fax: (852)2779789, Email: agc@agc.com.hk

MAIN CONTRACTOR :
Gammon

STRUCTURAL ENGINEER :
ARUP

FACADE CONSULTANT:
MEINHARDT

NOTE :
 1. ALL DIMENSIONS ARE IN mm.
 2. ALL ELEVATIONS ARE VIEWED FROM OUTSIDE.
 3. ALL DIMENSIONS TO BE VERIFIED ON SITE BEFORE FABRICATION.

LEGEND :
 X1 --- DETAIL MARK NO.
 X001 --- REFER SHEET NO.
 1. F.F.L. --- FINISHED FLOOR LEVEL
 2. S.F.L. --- STRUCTURAL FLOOR LEVEL
 3. (R) --- REVERSED DETAIL
 4. ▲ --- FIXING LOCATION
 5. △ --- FIXING LUG LOCATION
 6. GLASS LEGEND
 GLO1 --- 8mm+12mm AIR GAP+10mm THK. I.G.U.
 GLO1c --- 8mm+12mm AIR GAP+12mm THK. I.G.U.
 GLO2 --- 10mm THK. TEMPERED GLASS (SPANDREL GLASS)
 GLO3 --- 6mm+12mm AIR GAP+6mm THK. I.G.U.
 GLO4 --- 10mm THK. TEMPERED GLASS (PROTECTIVE BARRIER)
 GLO5 --- 6mm+12mm AIR GAP+8mm THK. I.G.U.

A	06/01/2021	REVISION SUBJECT TO ARCH.COMMENT	Ivan
NO.	DATE	REVISED	BY

JOB NO. : J-852
 PROJECT :
 PROPOSED RESIDENTIAL DEVELOPMENT
 AT 139 - 147 ARGYLE STREET,
 NKIL 6005, 6035 R.P., 6036 R.P.,
 6037 R.P. & 6038 R.P.
 TITLE :
 SCHEDULE FOR Plenum Box
 AT TOWER 3 (1-21F)

DATE : 05-FEB-20 SCALE : 1:100
 DRAWN BY : MN CHECKED BY : DW

美特鋁質有限公司
MIDI ALUMINIUM FABRICATOR LTD.
 Units 6-8, Sunray Industrial Centre, 1/F
 610 Cha Kwo Ling Road, Kowloon
 Tel:23489211-4 Fax:(852)27727666
 DWG NO. : J852-SD-PB-4307 REV. : A

ELEVATION

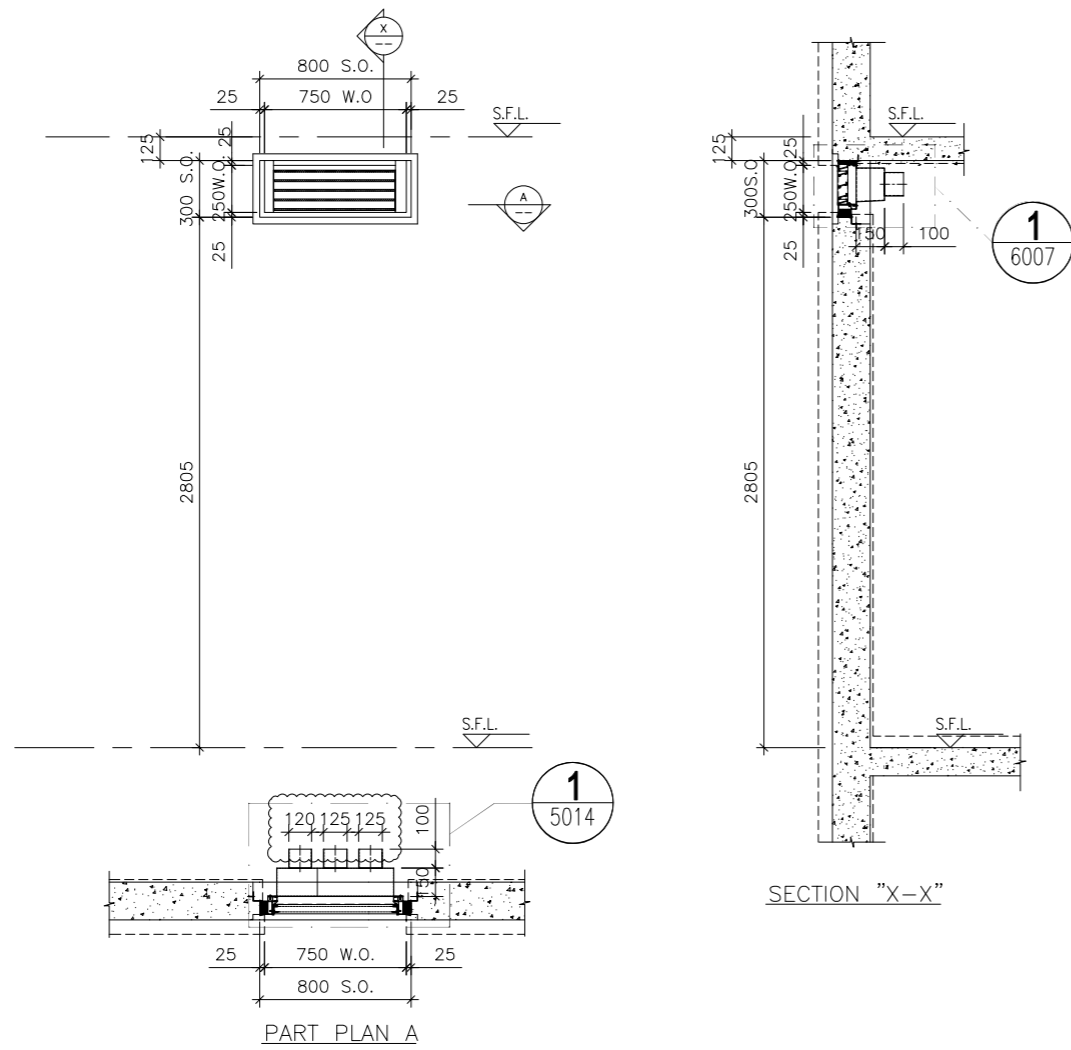

B.D. REF :

CLIENT :

ARCHITECT :
AGC DESIGN LTD
 100, 14/F, Olympic Plaza, 225, King's Road, North Point, Hong Kong
 Tel: (852) 27797812, Fax: (852) 27797133, Email: agc@agcdesign.com.hk

MAIN CONTRACTOR :
Gammon

STRUCTURAL ENGINEER :
ARUP

FACADE CONSULTANT:
MEINHARDT

NOTE :
 1. ALL DIMENSIONS ARE IN mm.
 2. ALL ELEVATIONS ARE VIEWED FROM OUTSIDE.
 3. ALL DIMENSIONS TO BE VERIFIED ON SITE BEFORE FABRICATION.

LEGEND :
 X1 --- DETAIL MARK NO.
 X001 --- REFER SHEET NO.
 1. F.F.L. --- FINISHED FLOOR LEVEL
 2. S.F.L. --- STRUCTURAL FLOOR LEVEL
 3. (R) --- REVERSED DETAIL
 4. ▲ --- FIXING LOCATION
 5. △ --- FIXING LUG LOCATION
 6. GLASS LEGEND
 GLO1 --- 8mm+12mm AIR GAP+10mm THK. I.G.U.
 GLO1c --- 8mm+12mm AIR GAP+12mm THK. I.G.U.
 GLO2 --- 10mm THK. TEMPERED GLASS (SPANDREL GLASS)
 GLO3 --- 6mm+12mm AIR GAP+6mm THK. I.G.U.
 GLO4 --- 10mm THK. TEMPERED GLASS (PROTECTIVE BARRIER)
 GLO5 --- 6mm+12mm AIR GAP+8mm THK. I.G.U.

A	06/01/2021	REVISION SUBJECT TO ARCH.COMMENT	Ivan
NO.	DATE	REVISED	BY

JOB NO. : J-852
 PROJECT :
 PROPOSED RESIDENTIAL DEVELOPMENT
 AT 139 - 147 ARGYLE STREET,
 NKIL 6005, 6035 R.P., 6036 R.P.,
 6037 R.P. & 6038 R.P.
 TITLE :
 SCHEDULE FOR Plenum Box
 AT TOWER 3 (1-21F)

DATE : 05-FEB-20 SCALE : 1:100
 DRAWN BY : MN CHECKED BY : DW

美特鋁質有限公司
MIDI ALUMINIUM FABRICATOR LTD.
 Units 6-8, Sunray Industrial Centre, 1/F
 610 Cha Kwo Ling Road, Kowloon
 Tel: 23489211-4 Fax: (852) 27727666
 DWG NO. : J852-SD-PB-4308 REV. : A

WINDOW MARK	W9 T3A
LOCATION	21/F Corridor AT TOWER 3 FLAT C
SECTION	50mm ALUM. SECTION
GLAZING	
QUANTITY	1
REMARKS	

ELEVATION

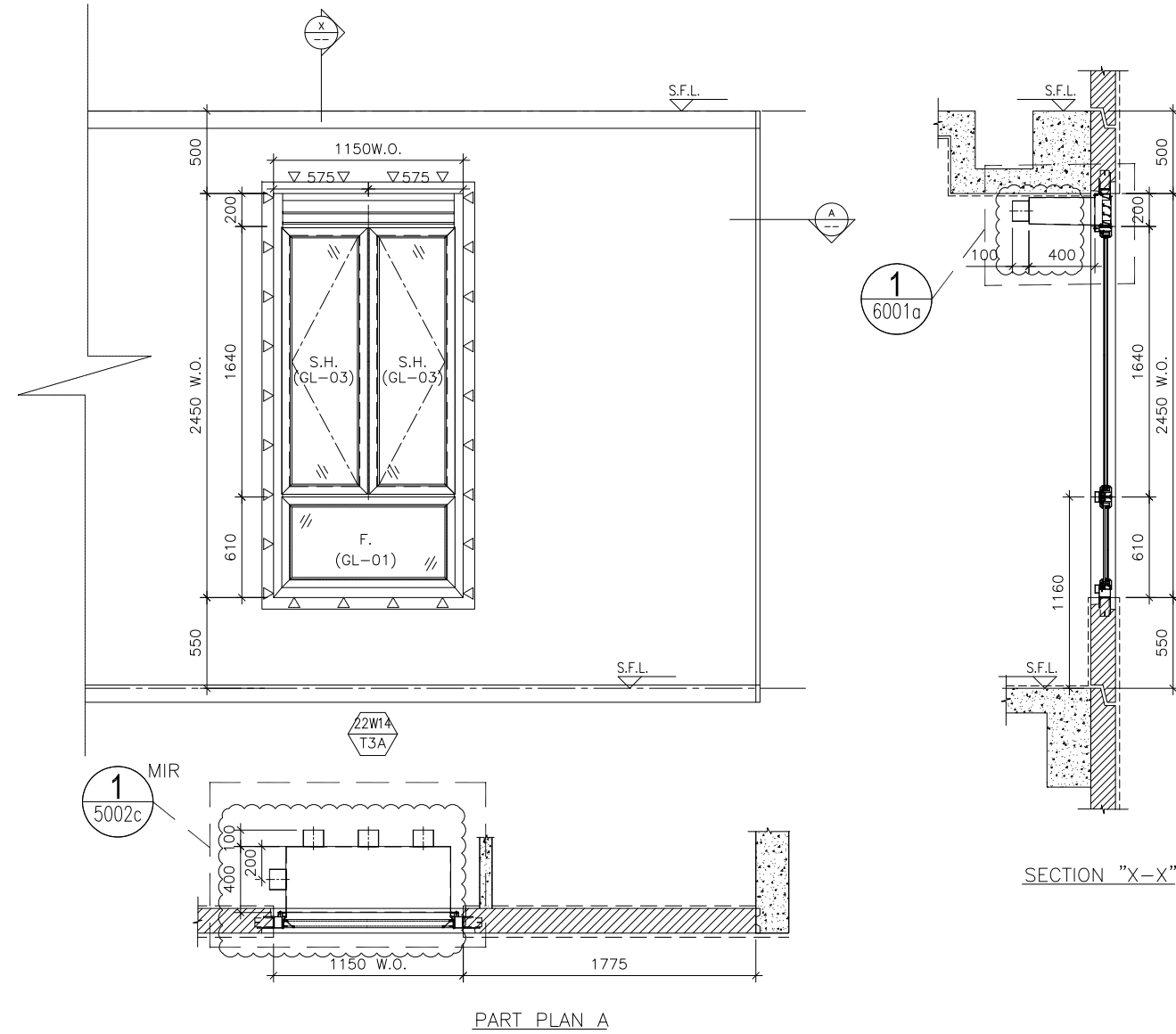

B.D. REF :

CLIENT :

ARCHITECT :

AGC
DESIGN LTD

MAIN CONTRACTOR :

Gammon

STRUCTURAL ENGINEER :

ARUP

FACADE CONSULTANT:

MEINHARDT

NOTE :

1. ALL DIMENSIONS ARE IN mm.
2. ALL ELEVATIONS ARE VIEWED FROM OUTSIDE.
3. ALL DIMENSIONS TO BE VERIFIED ON SITE BEFORE FABRICATION.

LEGEND :

- x1 — DETAIL MARK NO.
- x001 — REFER SHEET NO.

1. F.F.L. -- FINISHED FLOOR LEVEL
2. S.F.L. -- STRUCTURAL FLOOR LEVEL
3. (R) -- REVERSED DETAIL
4. ▲ -- FIXING LOCATION
5. △ -- FIXING LUG LOCATION

6. GLASS LEGEND

- GL01 -- 8mm+12mm AIR GAP+10mm THK. I.G.U.
- GL01a -- 8mm+9mm AIR GAP+12mm THK. I.G.U.
- GL03 -- 6mm+12mm AIR GAP+6mm THK. I.G.U.
- GL04 -- 10mm THK. TEMPERED GLASS (PROTECTIVE BARRIER)
- GL05 -- 6mm+12mm AIR GAP+8mm THK. I.G.U.

NO.	DATE	REVISION	BY
A	07/11/2020	REVISION SUBJECT TO ARCH.COMMENT	lvn

JOB NO. : J-852

PROJECT :
PROPOSED RESIDENTIAL DEVELOPMENT
AT 139 - 147 ARGYLE STREET,
NKIL 6005, 6035 R.P., 6036 R.P.,
6037 R.P. & 6038 R.P.

TITLE :
SCHEDULE FOR Plenum Box
AT TOWER 3 (22F)

DATE : 05-Dec-19 SCALE : 1:40

DRAWN BY : MN CHECKED BY : DW

美特鋁質有限公司
MIDI ALUMINIUM FABRICATOR LTD.
Units 6-8, Sunray Industrial Centre, 1/F
610 Cha Kwo Ling Road, Kowloon
Tel:23489211-4 Fax:(852)27727666

DWG NO. : J852-SD-PB-4309 REV. : A

WINDOW MARK	22W14 T3A
LOCATION	22/F M. BATH AT TOWER 3 FLAT A
SECTION	70mm ALUM. SECTION
GLAZING	GL-01, GL-03
QUANTITY	1
REMARKS	FACADE (PF-19)

ELEVATION

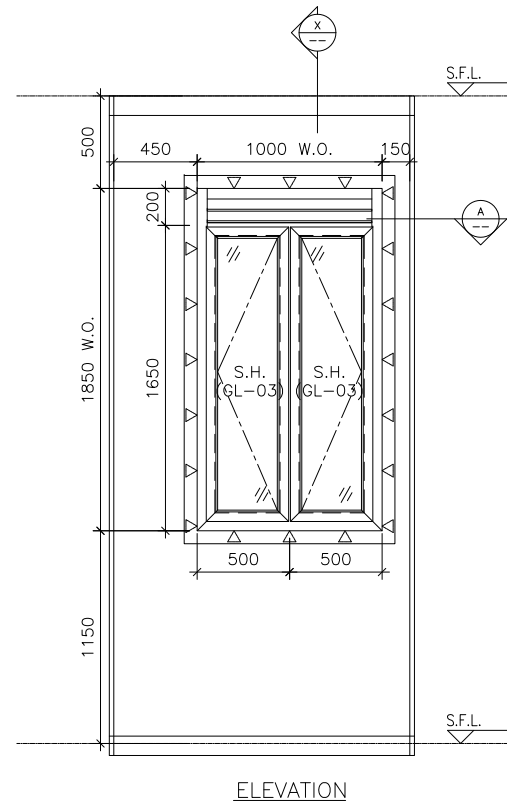

ELEVATION

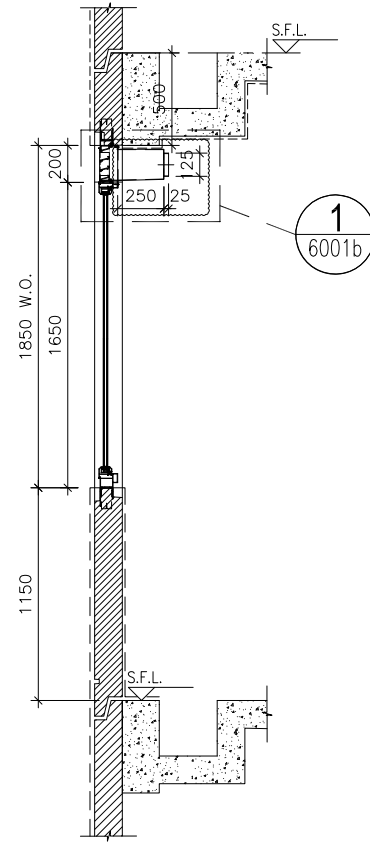

SECTION "X-X"

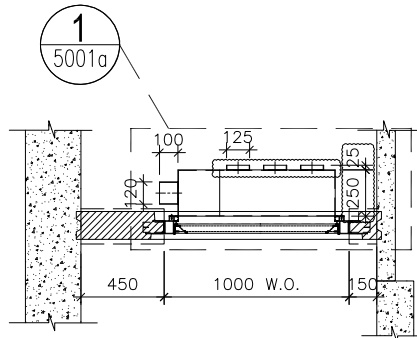

PART PLAN A

WINDOW MARK



LOCATION 22/F KIT. AT TOWER 3 FLAT C

SECTION 70mm ALUM. SECTION

GLAZING GL-03

QUANTITY 1

REMARKS FACADE (PF-25)

B.D. REF :

CLIENT :

ARCHITECT :



MAIN CONTRACTOR :



STRUCTURAL ENGINEER :



FACADE CONSULTANT:



NOTE :

1. ALL DIMENSIONS ARE IN mm.
2. ALL ELEVATIONS ARE VIEWED FROM OUTSIDE.
3. ALL DIMENSIONS TO BE VERIFIED ON SITE BEFORE FABRICATION.

LEGEND :

- (x1) --- DETAIL MARK NO.
- (x001) --- REFER SHEET NO.

1. F.F.L. --- FINISHED FLOOR LEVEL
2. S.F.L. --- STRUCTURAL FLOOR LEVEL
3. (R) --- REVERSED DETAIL
4. (A) --- FIXING LOCATION
5. (Δ) --- FIXING LUG LOCATION

6. GLASS LEGEND

- GL01 --- 8mm+12mm AIR GAP+10mm THK. I.G.U.
- GL01a --- 8mm+9mm AIR GAP+12mm THK. I.G.U.
- GL03 --- 6mm+12mm AIR GAP+6mm THK. I.G.U.
- GL04 --- 10mm THK. TEMPERED GLASS (PROTECTIVE BARRIER)
- GL05 --- 6mm+12mm AIR GAP+8mm THK. I.G.U.

B	05/03/2021	REVISION SUBJECT TO ARCH.COMMENT	Ivan
A	09/12/2020	REVISION SUBJECT TO ARCH.COMMENT	Ivan
NO.	DATE	REVISED	BY

JOB NO. : J-852

PROJECT :
PROPOSED RESIDENTIAL DEVELOPMENT
AT 139 - 147 ARGYLE STREET,
NKIL 6005, 6035 R.P., 6036 R.P.,
6037 R.P. & 6038 R.P.

TITLE :
SCHEDULE FOR Plenum Box
AT TOWER 3 (22F)

DATE : 05-Dec-19 SCALE : 1:40

DRAWN BY : MN CHECKED BY : DW



DWG NO. : J852-SD-PB-4310 REV. : B

ELEVATION

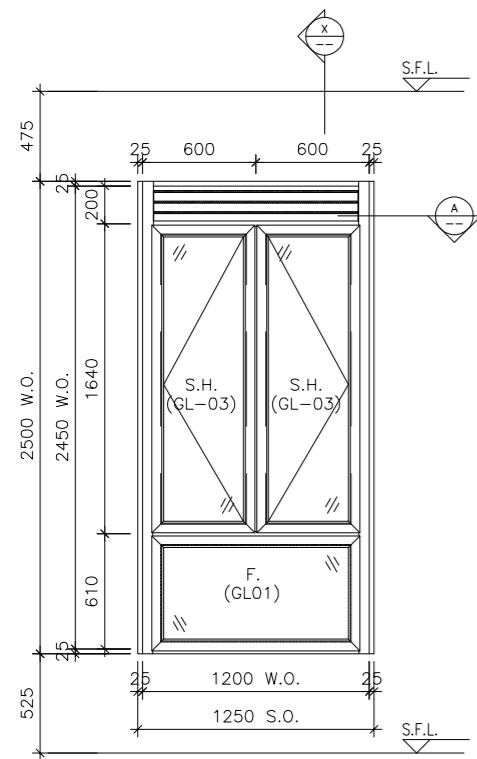

ELEVATION

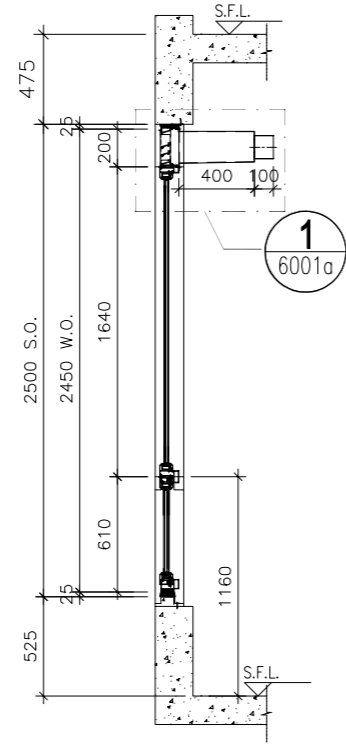

SECTION "X-X"

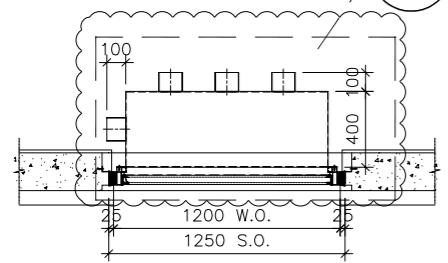

PART PLAN A

WINDOW MARK



LOCATION 22/F BATH AT TOWER 3 FLAT A

SECTION 70mm ALUM. SECTION

GLAZING GL-01, GL-03

QUANTITY 1

REMARKS

B.D. REF :

CLIENT :

ARCHITECT :



MAIN CONTRACTOR :



STRUCTURAL ENGINEER :



FACADE CONSULTANT:



NOTE :

1. ALL DIMENSIONS ARE IN mm.
2. ALL ELEVATIONS ARE VIEWED FROM OUTSIDE.
3. ALL DIMENSIONS TO BE VERIFIED ON SITE BEFORE FABRICATION.

LEGEND :

- X1 --- DETAIL MARK NO.
- X001 --- REFER SHEET NO.

1. F.F.L. --- FINISHED FLOOR LEVEL
2. S.F.L. --- STRUCTURAL FLOOR LEVEL
3. (R) --- REVERSED DETAIL

B	06/01/2021	REVISION SUBJECT TO ARCH.COMMENT	Ivan
A	09/12/2020	REVISION SUBJECT TO ARCH.COMMENT	Ivan
NO.	DATE	REVISED	BY

JOB NO. : J-852

PROJECT :
PROPOSED RESIDENTIAL DEVELOPMENT
AT 139 - 147 ARGYLE STREET,
NKIL 6005, 6035 R.P., 6036 R.P.,
6037 R.P. & 6038 R.P.

TITLE :
SCHEDULE FOR Plenum Box
AT TOWER 3 (22F)

DATE : 05-FEB-20 SCALE : 1:100

DRAWN BY : MN CHECKED BY : DW

美特鋁質有限公司
MIDI ALUMINIUM FABRICATOR LTD.
Units 6-8, Sunray Industrial Centre, 1/F
610 Cha Kwo Ling Road, Kowloon
Tel:23489211-4 Fax:(852)27727666

DWG NO. : J852-SD-PB-4311 REV. : B

ELEVATION

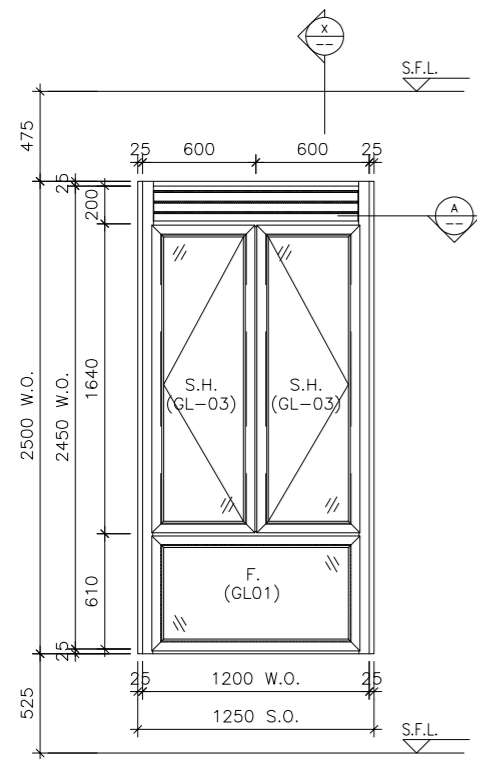

ELEVATION

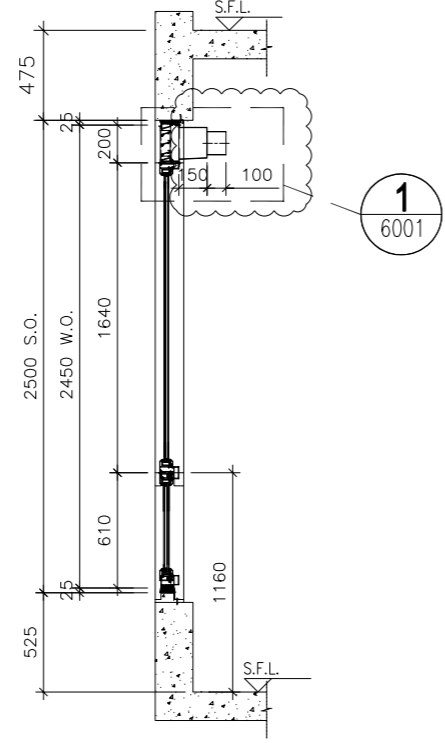

SECTION "X-X"

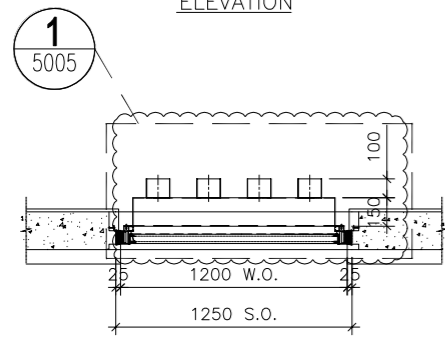

PART PLAN A

WINDOW MARK	22W8 T3A
LOCATION	22/F EN. B 3 AT TOWER 3 FLAT A
SECTION	70mm ALUM. SECTION
GLAZING	GL-01, GL-03
QUANTITY	1
REMARKS	

B.D. REF :

CLIENT :

ARCHITECT :
AGC DESIGN LTD
 1001, 14/F, Dynasty Plaza, 225 King's Road, North Point, Hong Kong
 Tel: (852) 27797882, Fax: (852) 27797823, Email: agc@agcdesign.com.hk

MAIN CONTRACTOR :
Gammon

STRUCTURAL ENGINEER :
ARUP

FACADE CONSULTANT:
MEINHARDT

NOTE :
 1. ALL DIMENSIONS ARE IN mm.
 2. ALL ELEVATIONS ARE VIEWED FROM OUTSIDE.
 3. ALL DIMENSIONS TO BE VERIFIED ON SITE BEFORE FABRICATION.

LEGEND :
 X1 — DETAIL MARK NO.
 X001 — REFER SHEET NO.

1. F.F.L. -- FINISHED FLOOR LEVEL
 2. S.F.L. -- STRUCTURAL FLOOR LEVEL
 3. (R) -- REVERSED DETAIL

NO.	DATE	REVISION	SUBJECT TO ARCH.COMMENT	BY
A	07/11/2020	REVISION	SUBJECT TO ARCH.COMMENT	Ivan

JOB NO. : J-852

PROJECT :
 PROPOSED RESIDENTIAL DEVELOPMENT
 AT 139 - 147 ARGYLE STREET,
 NKIL 6005, 6035 R.P., 6036 R.P.,
 6037 R.P. & 6038 R.P.

TITLE :
 SCHEDULE FOR Plenum Box
 AT TOWER 3 (22F)

DATE : 05-FEB-20 SCALE : 1:100

DRAWN BY : MN CHECKED BY : DW

美特鋁質有限公司
MIDI ALUMINIUM FABRICATOR LTD.
 Units 6-8, Sunray Industrial Centre, 1/F
 610 Cha Kwo Ling Road, Kowloon
 Tel: 23489211-4 Fax: (852) 27727666

DWG NO. : J852-SD-PB-4312 REV. : A

ELEVATION

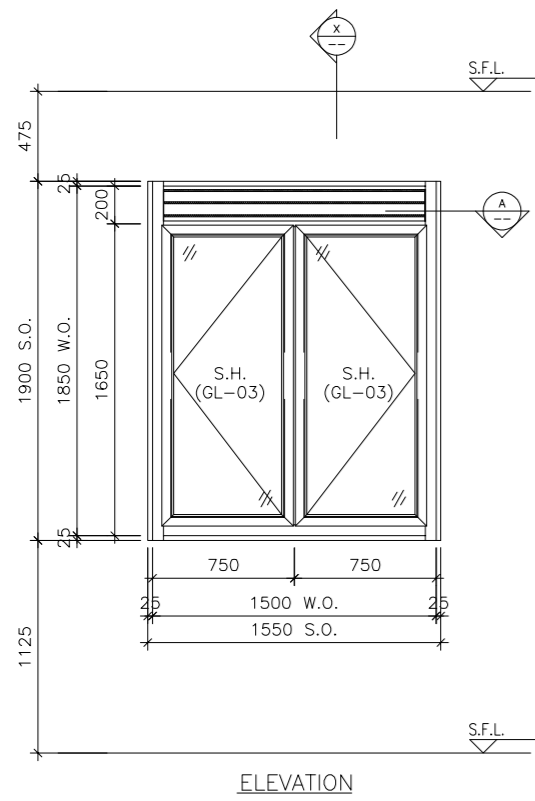

ELEVATION

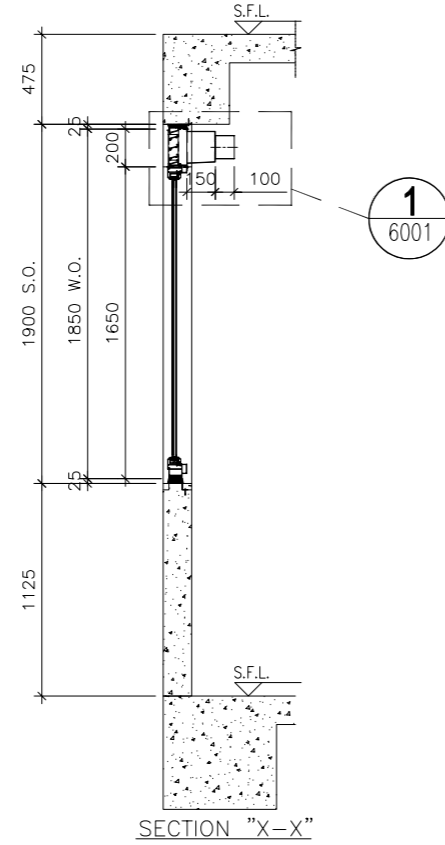

SECTION "X-X"

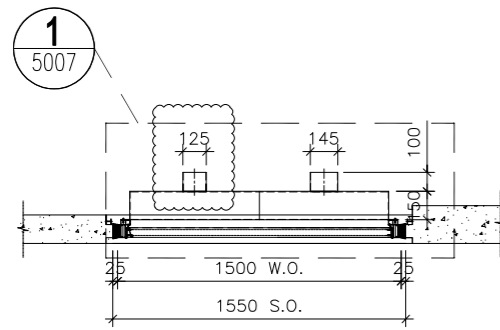

PART PLAN A

WINDOW MARK



LOCATION

22/F KIT. AT TOWER 3 FLAT A

SECTION

70mm ALUM. SECTION

GLAZING

GL-03

QUANTITY

1

REMARKS

B.D. REF :

CLIENT :

ARCHITECT :



MAIN CONTRACTOR :



STRUCTURAL ENGINEER :



FACADE CONSULTANT:



NOTE :

1. ALL DIMENSIONS ARE IN mm.
2. ALL ELEVATIONS ARE VIEWED FROM OUTSIDE.
3. ALL DIMENSIONS TO BE VERIFIED ON SITE BEFORE FABRICATION.

LEGEND :

- X1 --- DETAIL MARK NO.
- X001 --- REFER SHEET NO.

1. F.F.L. --- FINISHED FLOOR LEVEL
2. S.F.L. --- STRUCTURAL FLOOR LEVEL
3. (R) --- REVERSED DETAIL

B	06/01/2021	REVISION SUBJECT TO ARCH.COMMENT	Ivan
A	07/11/2020	REVISION SUBJECT TO ARCH.COMMENT	Ivan
NO.	DATE	REVISED	BY

JOB NO. : J-852

PROJECT :
PROPOSED RESIDENTIAL DEVELOPMENT
AT 139 - 147 ARGYLE STREET,
NKIL 6005, 6035 R.P., 6036 R.P.,
6037 R.P. & 6038 R.P.

TITLE :
SCHEDULE FOR Plenum Box
AT TOWER 3 (22F)

DATE : 05-FEB-20 SCALE : 1:100

DRAWN BY : MN CHECKED BY : DW

美特鋁質有限公司
MIDI ALUMINIUM FABRICATOR LTD.
Units 6-8, Sunray Industrial Centre, 1/F
610 Cha Kwo Ling Road, Kowloon
Tel:23489211-4 Fax:(852)27727666

DWG NO. : J852-SD-PB-4313 REV. : B

ELEVATION

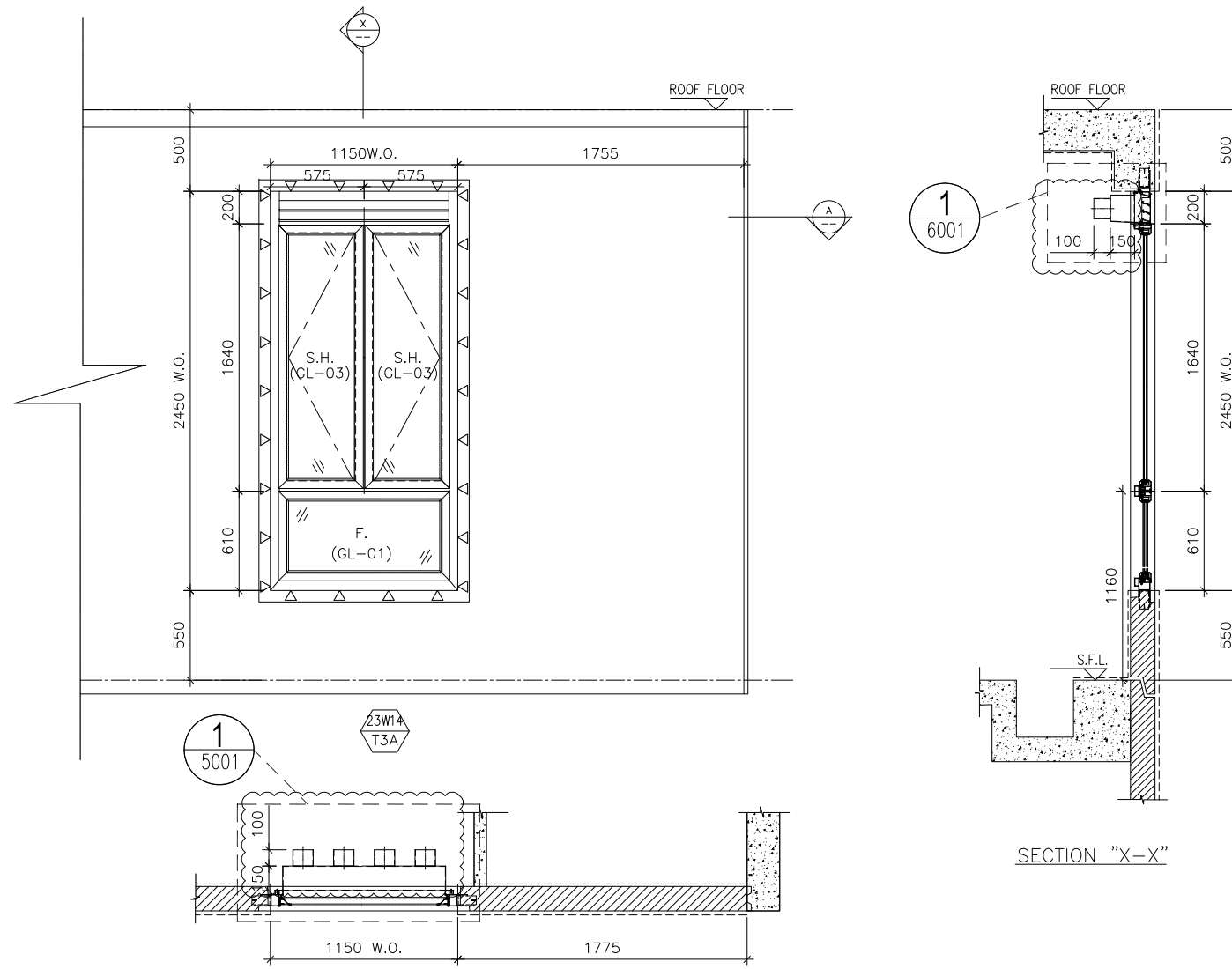

B.D. REF :

CLIENT :

ARCHITECT :
AGC DESIGN LTD
 101, 102, 103, 104, 105, 106, 107, 108, 109, 110, 111, 112, 113, 114, 115, 116, 117, 118, 119, 120, 121, 122, 123, 124, 125, 126, 127, 128, 129, 130, 131, 132, 133, 134, 135, 136, 137, 138, 139, 140, 141, 142, 143, 144, 145, 146, 147, 148, 149, 150, 151, 152, 153, 154, 155, 156, 157, 158, 159, 160, 161, 162, 163, 164, 165, 166, 167, 168, 169, 170, 171, 172, 173, 174, 175, 176, 177, 178, 179, 180, 181, 182, 183, 184, 185, 186, 187, 188, 189, 190, 191, 192, 193, 194, 195, 196, 197, 198, 199, 200, 201, 202, 203, 204, 205, 206, 207, 208, 209, 210, 211, 212, 213, 214, 215, 216, 217, 218, 219, 220, 221, 222, 223, 224, 225, 226, 227, 228, 229, 230, 231, 232, 233, 234, 235, 236, 237, 238, 239, 240, 241, 242, 243, 244, 245, 246, 247, 248, 249, 250, 251, 252, 253, 254, 255, 256, 257, 258, 259, 260, 261, 262, 263, 264, 265, 266, 267, 268, 269, 270, 271, 272, 273, 274, 275, 276, 277, 278, 279, 280, 281, 282, 283, 284, 285, 286, 287, 288, 289, 290, 291, 292, 293, 294, 295, 296, 297, 298, 299, 300, 301, 302, 303, 304, 305, 306, 307, 308, 309, 310, 311, 312, 313, 314, 315, 316, 317, 318, 319, 320, 321, 322, 323, 324, 325, 326, 327, 328, 329, 330, 331, 332, 333, 334, 335, 336, 337, 338, 339, 340, 341, 342, 343, 344, 345, 346, 347, 348, 349, 350, 351, 352, 353, 354, 355, 356, 357, 358, 359, 360, 361, 362, 363, 364, 365, 366, 367, 368, 369, 370, 371, 372, 373, 374, 375, 376, 377, 378, 379, 380, 381, 382, 383, 384, 385, 386, 387, 388, 389, 390, 391, 392, 393, 394, 395, 396, 397, 398, 399, 400, 401, 402, 403, 404, 405, 406, 407, 408, 409, 410, 411, 412, 413, 414, 415, 416, 417, 418, 419, 420, 421, 422, 423, 424, 425, 426, 427, 428, 429, 430, 431, 432, 433, 434, 435, 436, 437, 438, 439, 440, 441, 442, 443, 444, 445, 446, 447, 448, 449, 450, 451, 452, 453, 454, 455, 456, 457, 458, 459, 460, 461, 462, 463, 464, 465, 466, 467, 468, 469, 470, 471, 472, 473, 474, 475, 476, 477, 478, 479, 480, 481, 482, 483, 484, 485, 486, 487, 488, 489, 490, 491, 492, 493, 494, 495, 496, 497, 498, 499, 500, 501, 502, 503, 504, 505, 506, 507, 508, 509, 510, 511, 512, 513, 514, 515, 516, 517, 518, 519, 520, 521, 522, 523, 524, 525, 526, 527, 528, 529, 530, 531, 532, 533, 534, 535, 536, 537, 538, 539, 540, 541, 542, 543, 544, 545, 546, 547, 548, 549, 550, 551, 552, 553, 554, 555, 556, 557, 558, 559, 560, 561, 562, 563, 564, 565, 566, 567, 568, 569, 570, 571, 572, 573, 574, 575, 576, 577, 578, 579, 580, 581, 582, 583, 584, 585, 586, 587, 588, 589, 590, 591, 592, 593, 594, 595, 596, 597, 598, 599, 600, 601, 602, 603, 604, 605, 606, 607, 608, 609, 610, 611, 612, 613, 614, 615, 616, 617, 618, 619, 620, 621, 622, 623, 624, 625, 626, 627, 628, 629, 630, 631, 632, 633, 634, 635, 636, 637, 638, 639, 640, 641, 642, 643, 644, 645, 646, 647, 648, 649, 650, 651, 652, 653, 654, 655, 656, 657, 658, 659, 660, 661, 662, 663, 664, 665, 666, 667, 668, 669, 670, 671, 672, 673, 674, 675, 676, 677, 678, 679, 680, 681, 682, 683, 684, 685, 686, 687, 688, 689, 690, 691, 692, 693, 694, 695, 696, 697, 698, 699, 700, 701, 702, 703, 704, 705, 706, 707, 708, 709, 710, 711, 712, 713, 714, 715, 716, 717, 718, 719, 720, 721, 722, 723, 724, 725, 726, 727, 728, 729, 730, 731, 732, 733, 734, 735, 736, 737, 738, 739, 740, 741, 742, 743, 744, 745, 746, 747, 748, 749, 750, 751, 752, 753, 754, 755, 756, 757, 758, 759, 760, 761, 762, 763, 764, 765, 766, 767, 768, 769, 770, 771, 772, 773, 774, 775, 776, 777, 778, 779, 780, 781, 782, 783, 784, 785, 786, 787, 788, 789, 790, 791, 792, 793, 794, 795, 796, 797, 798, 799, 800, 801, 802, 803, 804, 805, 806, 807, 808, 809, 810, 811, 812, 813, 814, 815, 816, 817, 818, 819, 820, 821, 822, 823, 824, 825, 826, 827, 828, 829, 830, 831, 832, 833, 834, 835, 836, 837, 838, 839, 840, 841, 842, 843, 844, 845, 846, 847, 848, 849, 850, 851, 852, 853, 854, 855, 856, 857, 858, 859, 860, 861, 862, 863, 864, 865, 866, 867, 868, 869, 870, 871, 872, 873, 874, 875, 876, 877, 878, 879, 880, 881, 882, 883, 884, 885, 886, 887, 888, 889, 890, 891, 892, 893, 894, 895, 896, 897, 898, 899, 900, 901, 902, 903, 904, 905, 906, 907, 908, 909, 910, 911, 912, 913, 914, 915, 916, 917, 918, 919, 920, 921, 922, 923, 924, 925, 926, 927, 928, 929, 930, 931, 932, 933, 934, 935, 936, 937, 938, 939, 940, 941, 942, 943, 944, 945, 946, 947, 948, 949, 950, 951, 952, 953, 954, 955, 956, 957, 958, 959, 960, 961, 962, 963, 964, 965, 966, 967, 968, 969, 970, 971, 972, 973, 974, 975, 976, 977, 978, 979, 980, 981, 982, 983, 984, 985, 986, 987, 988, 989, 990, 991, 992, 993, 994, 995, 996, 997, 998, 999, 1000

MAIN CONTRACTOR :
Gammon

STRUCTURAL ENGINEER :
ARUP

FACADE CONSULTANT:
MEINHARDT

NOTE :
 1. ALL DIMENSIONS ARE IN mm.
 2. ALL ELEVATIONS ARE VIEWED FROM OUTSIDE.
 3. ALL DIMENSIONS TO BE VERIFIED ON SITE BEFORE FABRICATION.

LEGEND :
 x1 --- DETAIL MARK NO.
 x001 --- REFER SHEET NO.
 1. F.F.L. --- FINISHED FLOOR LEVEL
 2. S.F.L. --- STRUCTURAL FLOOR LEVEL
 3. (R) --- REVERSED DETAIL
 4. ▲ --- FIXING LOCATION
 5. △ --- FIXING LUG LOCATION
 6. GLASS LEGEND
 GL01 --- 8mm+12mm AIR GAP+10mm THK. I.G.U.
 GL01a --- 8mm+9mm AIR GAP+12mm THK. I.G.U.
 GL02 --- 10mm THK. TEMPERED GLASS (SPANDREL GLASS)
 GL03 --- 6mm+12mm AIR GAP+6mm THK. I.G.U.
 GL04 --- 10mm THK. TEMPERED GLASS (PROTECTIVE BARRIER)
 GL05 --- 6mm+12mm AIR GAP+8mm THK. I.G.U.

NO.	DATE	REVISION	BY
A	07/11/2020	REVISION SUBJECT TO ARCH.COMMENT	lvav

JOB NO. : J-852
 PROJECT :
 PROPOSED RESIDENTIAL DEVELOPMENT
 AT 139 - 147 ARGYLE STREET,
 NKIL 6005, 6035 R.P., 6036 R.P.,
 6037 R.P. & 6038 R.P.

TITLE :
 SCHEDULE FOR Plenum Box
 AT TOWER 3 (23F)

DATE : 05-Dec-19 SCALE : 1:40

DRAWN BY : MN CHECKED BY : DW

美特鋁質有限公司
MIDI ALUMINIUM FABRICATOR LTD.
 Units 6-8, Sunray Industrial Centre, 1/F
 610 Cha Kwo Ling Road, Kowloon
 Tel:23489211-4 Fax:(852)2727666

DWG NO. : J852-SD-PB-4314 REV. : A

WINDOW MARK	23W14 T3A
LOCATION	23/F M.B AT TOWER 3 FLAT A
SECTION	70mm ALUM. SECTION
GLAZING	GL-01, GL-03
QUANTITY	1
REMARKS	FACADE (PF-19)

ELEVATION

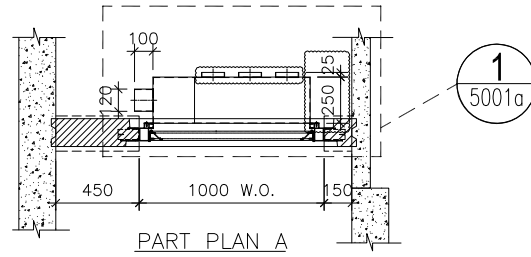
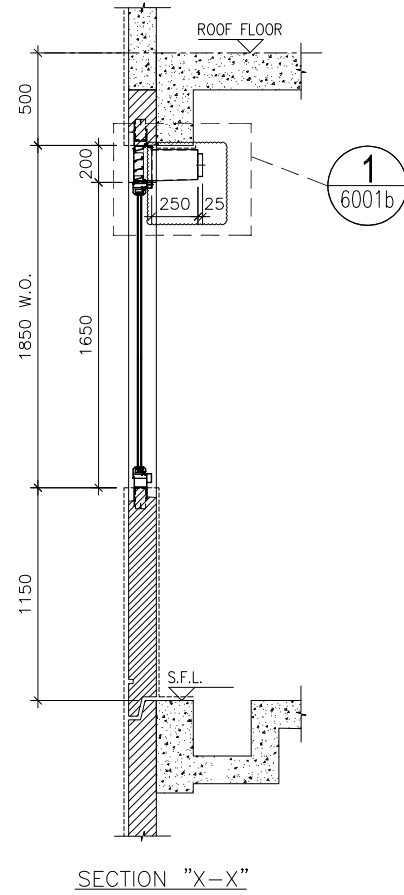
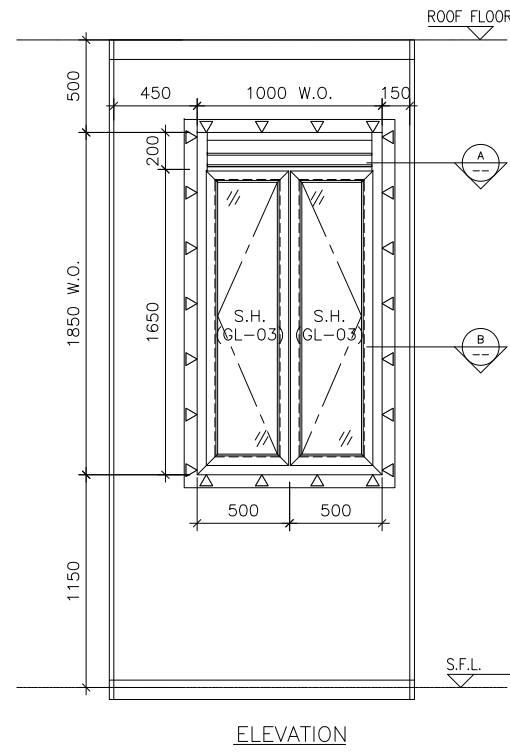

WINDOW MARK



LOCATION 23/F KIT. AT TOWER 3 FLAT C

SECTION 70mm ALUM. SECTION

GLAZING GL-03

QUANTITY 1

REMARKS FACADE (PF-25)

B.D. REF :

CLIENT :

ARCHITECT :

AGC
DESIGN LTD

MAIN CONTRACTOR :

Gammon

STRUCTURAL ENGINEER :

ARUP

FACADE CONSULTANT:

MEINHARDT

NOTE :

1. ALL DIMENSIONS ARE IN mm.
2. ALL ELEVATIONS ARE VIEWED FROM OUTSIDE.
3. ALL DIMENSIONS TO BE VERIFIED ON SITE BEFORE FABRICATION.

LEGEND :

- x1 --- DETAIL MARK NO.
- x001 --- REFER SHEET NO.

1. F.F.L. --- FINISHED FLOOR LEVEL
2. S.F.L. --- STRUCTURAL FLOOR LEVEL
3. (R) --- REVERSED DETAIL
4. ▲ --- FIXING LOCATION
5. △ --- FIXING LUG LOCATION

6. GLASS LEGEND

- GL01 --- 8mm+12mm AIR GAP+10mm THK. I.G.U.
- GL01a --- 8mm+9mm AIR GAP+12mm THK. I.G.U.
- GL02 --- 10mm THK. TEMPERED GLASS (SPANDREL GLASS)
- GL03 --- 6mm+12mm AIR GAP+6mm THK. I.G.U.
- GL04 --- 10mm THK. TEMPERED GLASS (PROTECTIVE BARRIER)
- GL05 --- 6mm+12mm AIR GAP+8mm THK. I.G.U.

NO.	DATE	REVISION	BY
A	05/03/2021	REVISION SUBJECT TO ARCH.COMMENT	lvart

JOB NO. : J-852

PROJECT :
PROPOSED RESIDENTIAL DEVELOPMENT
AT 139 - 147 ARGYLE STREET,
NKIL 6005, 6035 R.P., 6036 R.P.,
6037 R.P. & 6038 R.P.

TITLE :
SCHEDULE FOR Plenum Box
AT TOWER 3 (23F)

DATE : 05-Dec-19 SCALE : 1:40

DRAWN BY : MN CHECKED BY : DW

美特鋁質有限公司
MIDI ALUMINIUM FABRICATOR LTD.
Units 6-8, Sunray Industrial Centre, 1/F
610 Cha Kwo Ling Road, Kowloon
Tel:23489211-4 Fax:(852)2727666

DWG NO. : J852-SD-PB-4315 REV. : A

ELEVATION

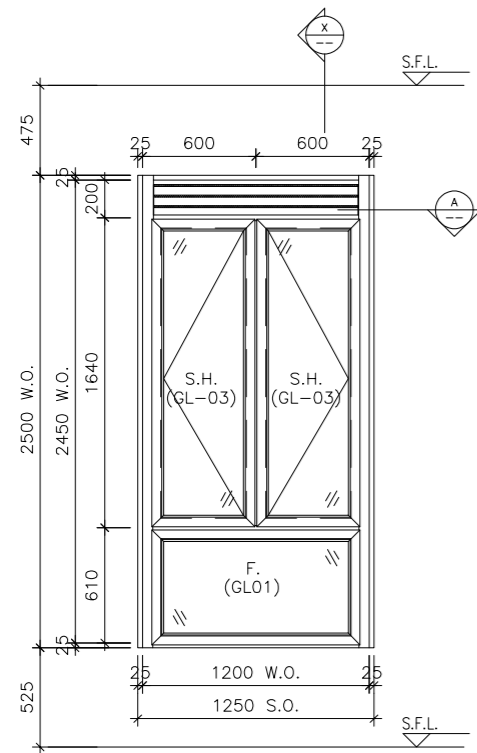

ELEVATION

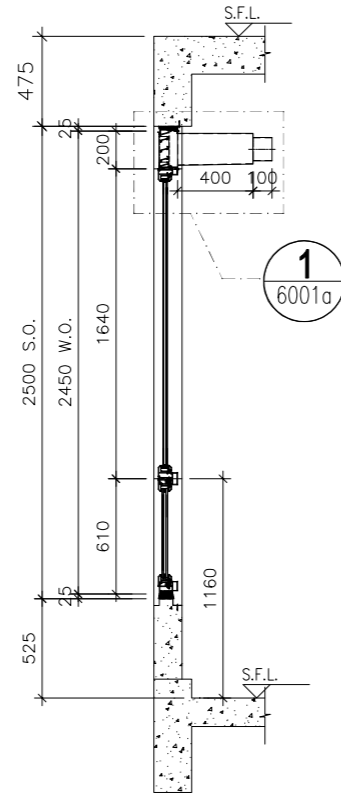

SECTION "X-X"

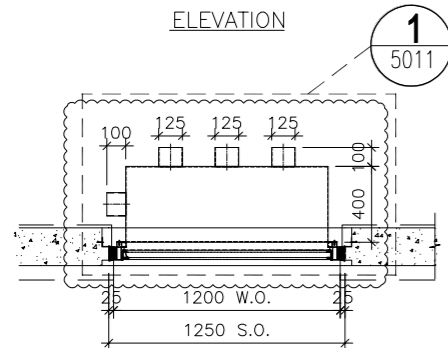

PART PLAN A

WINDOW MARK



LOCATION

23/F BATH AT TOWER 3 FLAT A

SECTION

70mm ALUM. SECTION

GLAZING

GL-01, GL-03

QUANTITY

1

REMARKS

B.D. REF :

CLIENT :

ARCHITECT :
AGC DESIGN LTD
 1001, 14/F, Dynasty Plaza, 225 King's Road, North Point, Hong Kong
 Tel: (852)27797816, Fax: (852)27797133, Email: agc@agcdesign.com.hk

MAIN CONTRACTOR :
Gammon

STRUCTURAL ENGINEER :
ARUP

FACADE CONSULTANT:
MEINHARDT

NOTE :
 1. ALL DIMENSIONS ARE IN mm.
 2. ALL ELEVATIONS ARE VIEWED FROM OUTSIDE.
 3. ALL DIMENSIONS TO BE VERIFIED ON SITE BEFORE FABRICATION.

LEGEND :
 X1 --- DETAIL MARK NO.
 X001 --- REFER SHEET NO.
 1. F.F.L. --- FINISHED FLOOR LEVEL
 2. S.F.L. --- STRUCTURAL FLOOR LEVEL
 3. (R) --- REVERSED DETAIL

A NO.	DATE	REVISION SUBJECT TO ARCH.COMMENT REVISED	BY
A	06/01/2021	REVISION SUBJECT TO ARCH.COMMENT	Ivan

JOB NO. : J-852
 PROJECT : PROPOSED RESIDENTIAL DEVELOPMENT AT 139 - 147 ARGYLE STREET, NKIL 6005, 6035 R.P., 6036 R.P., 6037 R.P. & 6038 R.P.

TITLE : SCHEDULE FOR Plenum Box AT TOWER 3 (23F)

DATE : 05-FEB-20 SCALE : 1:100
 DRAWN BY : MN CHECKED BY : DW

美特鋁質有限公司
MIDI ALUMINIUM FABRICATOR LTD.
 Units 6-8, Sunray Industrial Centre, 1/F
 610 Cha Kwo Ling Road, Kowloon
 Tel:23489211-4 Fax:(852)27727666

DWG NO. : J852-SD-PB-4316 REV. : A

ELEVATION

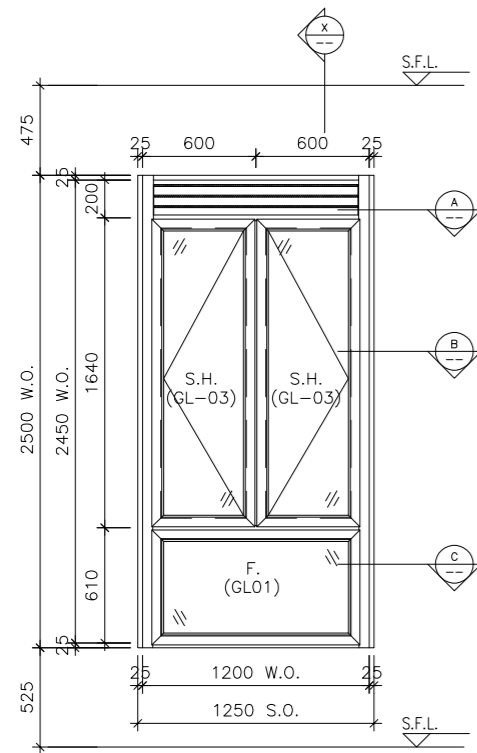

ELEVATION

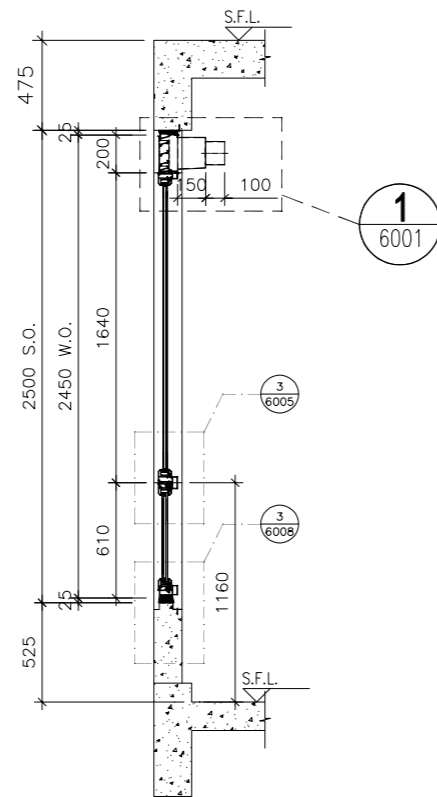

SECTION "X-X"

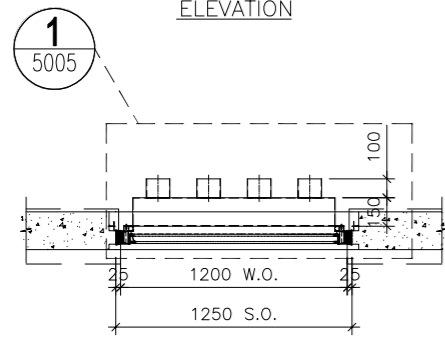

PART PLAN A

WINDOW MARK	23WB T3A
LOCATION	23/F EN. B 3 AT TOWER 3 FLAT A
SECTION	70mm ALUM. SECTION
GLAZING	GL-01, GL-03
QUANTITY	1
REMARKS	

B.D. REF :

CLIENT :

ARCHITECT :
AGC DESIGN LTD
 1001, 14/F, Dynasty Plaza, 225, King's Road, North Point, Hong Kong
 Tel: (852) 27797812, Fax: (852) 27797133, Email: agc@agcdesign.com.hk

MAIN CONTRACTOR :
Gammon

STRUCTURAL ENGINEER :
ARUP

FACADE CONSULTANT:
MEINHARDT

NOTE :
 1. ALL DIMENSIONS ARE IN mm.
 2. ALL ELEVATIONS ARE VIEWED FROM OUTSIDE.
 3. ALL DIMENSIONS TO BE VERIFIED ON SITE BEFORE FABRICATION.

LEGEND :
 X1 --- DETAIL MARK NO.
 X001 --- REFER SHEET NO.

1. F.F.L. --- FINISHED FLOOR LEVEL
 2. S.F.L. --- STRUCTURAL FLOOR LEVEL
 3. (R) --- REVERSED DETAIL

NO.	DATE	REVISED	BY
-----	------	---------	----

JOB NO. : J-852
 PROJECT : PROPOSED RESIDENTIAL DEVELOPMENT AT 139 - 147 ARGYLE STREET, NKIL 6005, 6035 R.P., 6036 R.P., 6037 R.P. & 6038 R.P.
 TITLE : SCHEDULE FOR Plenum Box AT TOWER 3 (23F)

DATE : 05-FEB-20 SCALE : 1:100
 DRAWN BY : MN CHECKED BY : DW

美特鋁質有限公司
MIDI ALUMINIUM FABRICATOR LTD.
 Units 6-8, Sunray Industrial Centre, 1/F
 610 Cha Kwo Ling Road, Kowloon
 Tel: 23489211-4 Fax: (852) 27727666
 DWG NO. : J852-SD-PB-4317 REV. : -

ELEVATION

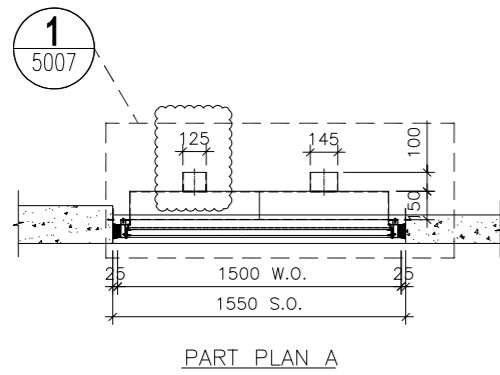
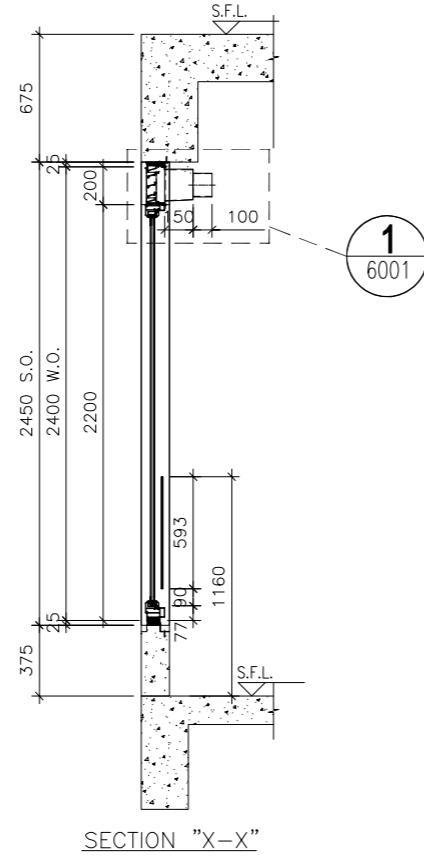
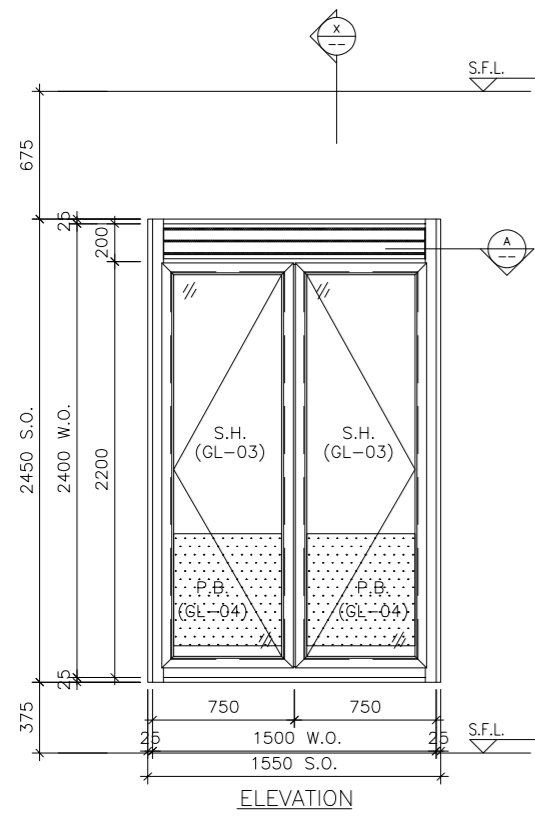

WINDOW MARK



LOCATION

23/F KIT. AT TOWER 3 FLAT A

SECTION

70mm ALUM. SECTION

GLAZING

GL-03

QUANTITY

1

REMARKS

B.D. REF :

CLIENT :

ARCHITECT :



MAIN CONTRACTOR :



STRUCTURAL ENGINEER :



FACADE CONSULTANT:



- NOTE :
1. ALL DIMENSIONS ARE IN mm.
 2. ALL ELEVATIONS ARE VIEWED FROM OUTSIDE.
 3. ALL DIMENSIONS TO BE VERIFIED ON SITE BEFORE FABRICATION.

- LEGEND :
- X1 — DETAIL MARK NO.
 - X001 — REFER SHEET NO.

1. F.F.L. -- FINISHED FLOOR LEVEL
2. S.F.L. -- STRUCTURAL FLOOR LEVEL
3. (R) -- REVERSED DETAIL

A NO.	DATE	REVISION SUBJECT TO ARCH.COMMENT REVERSED	BY
A	06/01/2021	REVISION SUBJECT TO ARCH.COMMENT	Ivan

JOB NO. : J-852

PROJECT : PROPOSED RESIDENTIAL DEVELOPMENT AT 139 - 147 ARGYLE STREET, NKIL 6005, 6035 R.P., 6036 R.P., 6037 R.P. & 6038 R.P.

TITLE : SCHEDULE FOR Plenum Box AT TOWER 3 (23F)

DATE : 05-FEB-20 SCALE : 1:100

DRAWN BY : MN CHECKED BY : DW

美特鋁質有限公司
MIDI ALUMINIUM FABRICATOR LTD.
Units 6-8, Sunray Industrial Centre, 1/F
610 Cha Kwo Ling Road, Kowloon
Tel:23489211-4 Fax:(852)27727666

DWG NO. : J852-SD-PB-4318 REV. : A

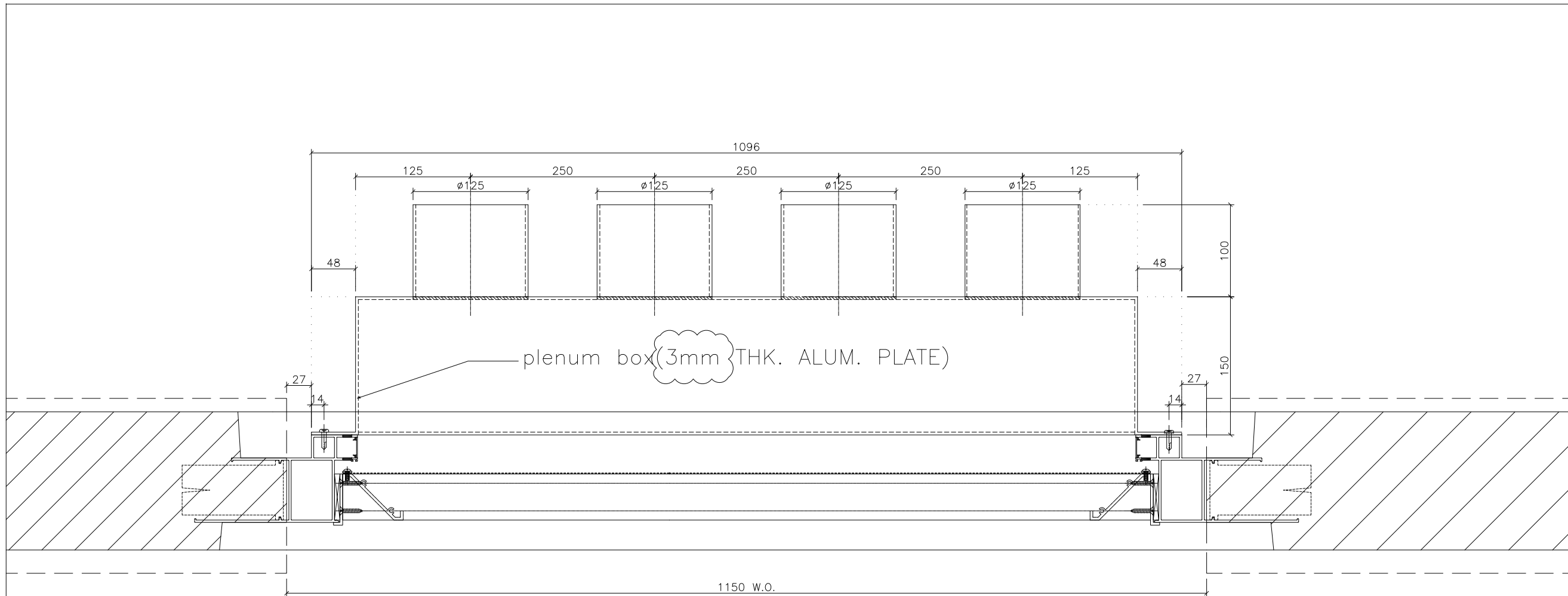

1 HORIZONTAL DETAIL OUTSIDE

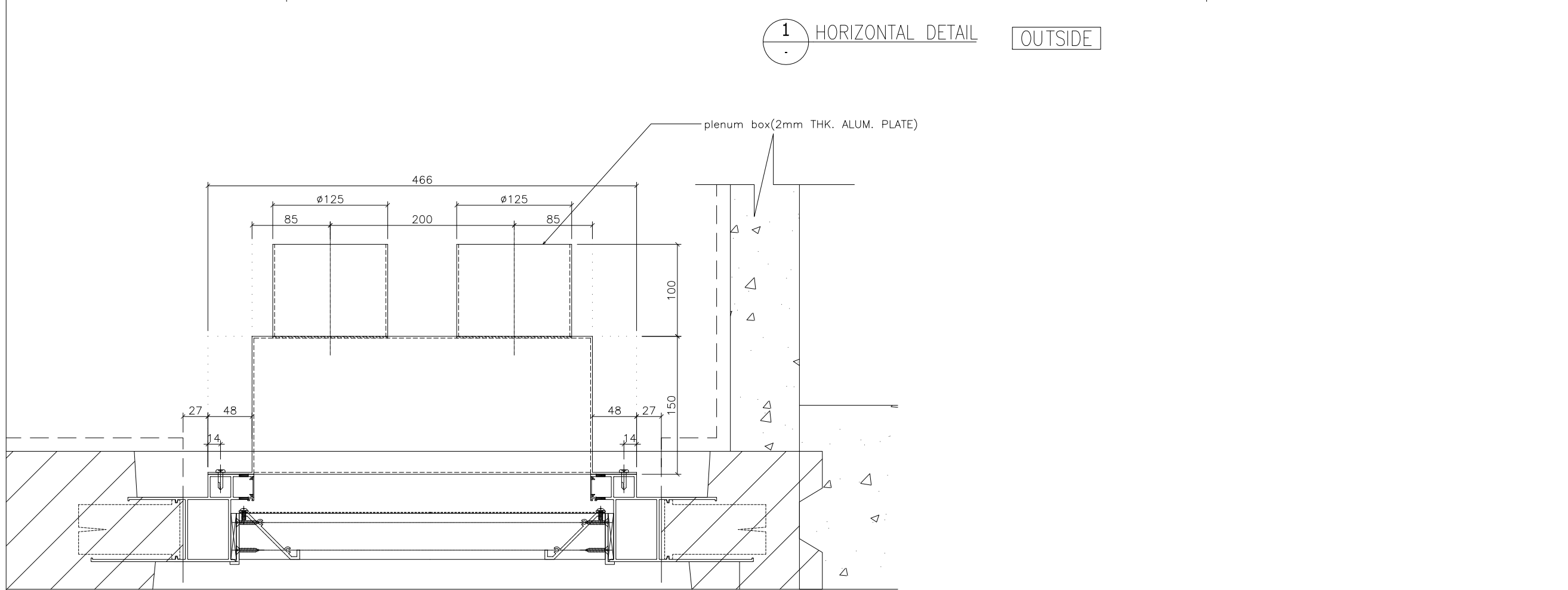

2 HORIZONTAL DETAIL OUTSIDE

B.D. REF :

CLIENT :

ARCHITECT :
AGC DESIGN LTD
 110, 112, 114, 116, 118, 120, 122, 124, 126, 128, 130, 132, 134, 136, 138, 140, 142, 144, 146, 148, 150, 152, 154, 156, 158, 160, 162, 164, 166, 168, 170, 172, 174, 176, 178, 180, 182, 184, 186, 188, 190, 192, 194, 196, 198, 200, 202, 204, 206, 208, 210, 212, 214, 216, 218, 220, 222, 224, 226, 228, 230, 232, 234, 236, 238, 240, 242, 244, 246, 248, 250, 252, 254, 256, 258, 260, 262, 264, 266, 268, 270, 272, 274, 276, 278, 280, 282, 284, 286, 288, 290, 292, 294, 296, 298, 300, 302, 304, 306, 308, 310, 312, 314, 316, 318, 320, 322, 324, 326, 328, 330, 332, 334, 336, 338, 340, 342, 344, 346, 348, 350, 352, 354, 356, 358, 360, 362, 364, 366, 368, 370, 372, 374, 376, 378, 380, 382, 384, 386, 388, 390, 392, 394, 396, 398, 400, 402, 404, 406, 408, 410, 412, 414, 416, 418, 420, 422, 424, 426, 428, 430, 432, 434, 436, 438, 440, 442, 444, 446, 448, 450, 452, 454, 456, 458, 460, 462, 464, 466, 468, 470, 472, 474, 476, 478, 480, 482, 484, 486, 488, 490, 492, 494, 496, 498, 500, 502, 504, 506, 508, 510, 512, 514, 516, 518, 520, 522, 524, 526, 528, 530, 532, 534, 536, 538, 540, 542, 544, 546, 548, 550, 552, 554, 556, 558, 560, 562, 564, 566, 568, 570, 572, 574, 576, 578, 580, 582, 584, 586, 588, 590, 592, 594, 596, 598, 600, 602, 604, 606, 608, 610, 612, 614, 616, 618, 620, 622, 624, 626, 628, 630, 632, 634, 636, 638, 640, 642, 644, 646, 648, 650, 652, 654, 656, 658, 660, 662, 664, 666, 668, 670, 672, 674, 676, 678, 680, 682, 684, 686, 688, 690, 692, 694, 696, 698, 700, 702, 704, 706, 708, 710, 712, 714, 716, 718, 720, 722, 724, 726, 728, 730, 732, 734, 736, 738, 740, 742, 744, 746, 748, 750, 752, 754, 756, 758, 760, 762, 764, 766, 768, 770, 772, 774, 776, 778, 780, 782, 784, 786, 788, 790, 792, 794, 796, 798, 800, 802, 804, 806, 808, 810, 812, 814, 816, 818, 820, 822, 824, 826, 828, 830, 832, 834, 836, 838, 840, 842, 844, 846, 848, 850, 852, 854, 856, 858, 860, 862, 864, 866, 868, 870, 872, 874, 876, 878, 880, 882, 884, 886, 888, 890, 892, 894, 896, 898, 900, 902, 904, 906, 908, 910, 912, 914, 916, 918, 920, 922, 924, 926, 928, 930, 932, 934, 936, 938, 940, 942, 944, 946, 948, 950, 952, 954, 956, 958, 960, 962, 964, 966, 968, 970, 972, 974, 976, 978, 980, 982, 984, 986, 988, 990, 992, 994, 996, 998, 1000

MAIN CONTRACTOR :
Gammon

STRUCTURAL ENGINEER :
ARUP

FACADE CONSULTANT:
MEINHARDT

NOTE :

1. ALL DIMENSIONS ARE IN mm.
2. ALL ELEVATIONS ARE VIEWED FROM OUTSIDE.
3. ALL DIMENSIONS TO BE VERIFIED ON SITE BEFORE FABRICATION.

LEGEND :

x1 — DETAIL MARK NO.
 x001 — REFER SHEET NO.

1. F.F.L. — FINISHED FLOOR LEVEL
2. S.F.L. — STRUCTURAL FLOOR LEVEL
3. (A) — REVERSED DETAIL
 — FIXING LOCATION
 — FIXING LUG LOCATION

GLASS LEGEND

GL01 — 8mm+12mm AIR GAP+10mm THK. I.G.U.
 GL01a — 8mm+9mm AIR GAP+12mm THK. I.G.U.
 GL03 — 6mm+12mm AIR GAP+6mm THK. I.G.U.
 GL04 — 10mm THK. TEMPERED GLASS (PROTECTIVE BARRIER)
 GL05 — 6mm+12mm AIR GAP+8mm THK. I.G.U.

NO.	DATE	REVISION	BY
A	09/12/2020	REVISION SUBJECT TO ARCH.COMMENT	lv

JOB NO. : J-852

PROJECT :
 PROPOSED RESIDENTIAL DEVELOPMENT
 AT 139 - 147 ARGYLE STREET,
 NKIL 6005, 6035 R.P., 6036 R.P.,
 6037 R.P. & 6038 R.P.

TITLE :
 DETAIL FOR
 Plenum Box

DATE : 05-Dec-19 SCALE : 1:2

DRAWN BY : MN CHECKED BY : DW

美特鋁質有限公司
MIDI ALUMINIUM FABRICATOR LTD.
 Units 6-8, Sunray Industrial Centre, 1/F
 610 Cha Kwo Ling Road, Kowloon
 Tel:23489211-4 Fax:(852)2727666

DWG NO. : J852-SD-PB-5001 REV. : A

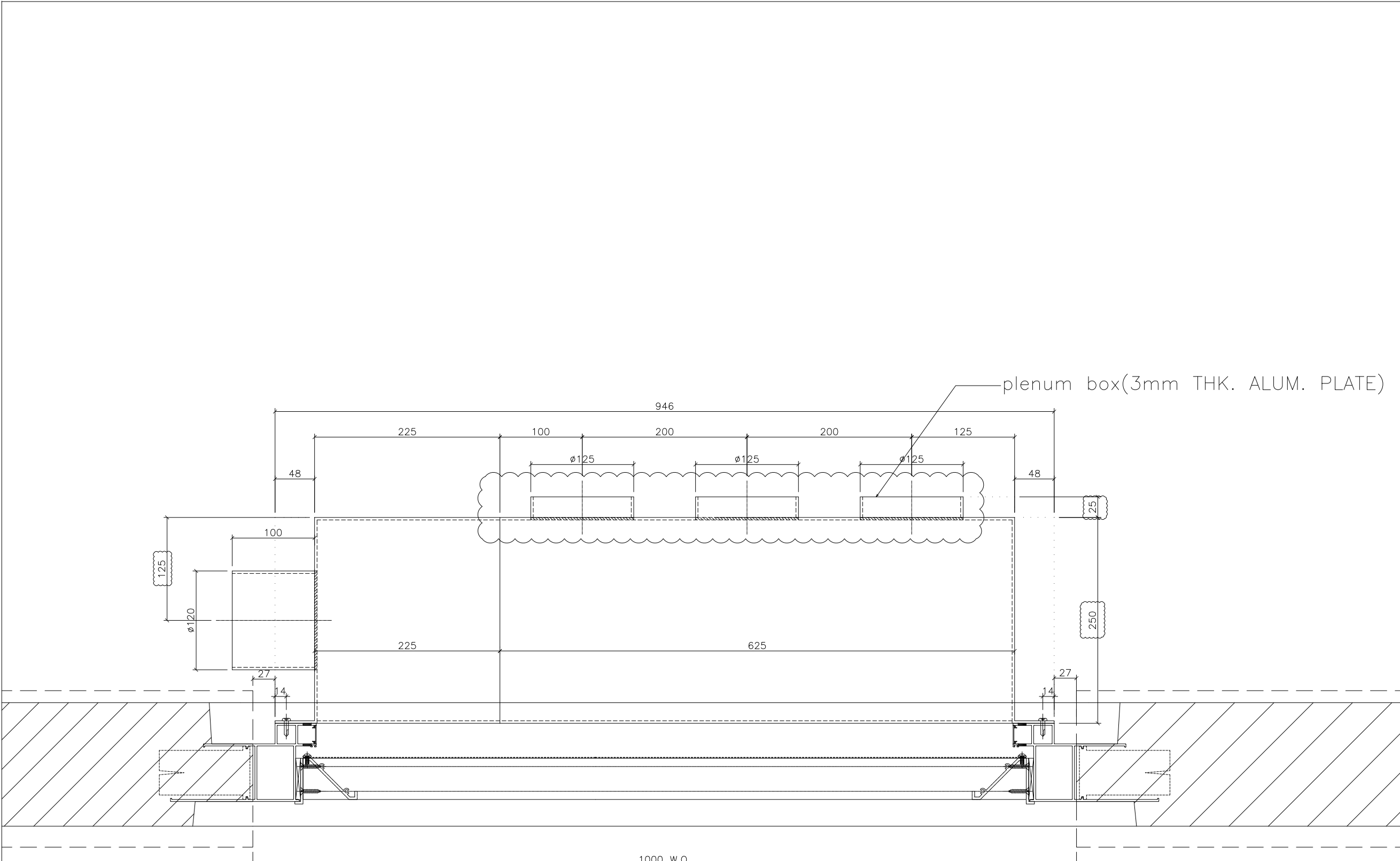

1 HORIZONTAL DETAIL SCALE 1:1 OUTSIDE

B.D. REF :

CLIENT :

ARCHITECT :
AGC DESIGN LTD
 181, 182, 183, 184, 185, 186, 187, 188, 189, 190, 191, 192, 193, 194, 195, 196, 197, 198, 199, 200, 201, 202, 203, 204, 205, 206, 207, 208, 209, 210, 211, 212, 213, 214, 215, 216, 217, 218, 219, 220, 221, 222, 223, 224, 225, 226, 227, 228, 229, 230, 231, 232, 233, 234, 235, 236, 237, 238, 239, 240, 241, 242, 243, 244, 245, 246, 247, 248, 249, 250, 251, 252, 253, 254, 255, 256, 257, 258, 259, 260, 261, 262, 263, 264, 265, 266, 267, 268, 269, 270, 271, 272, 273, 274, 275, 276, 277, 278, 279, 280, 281, 282, 283, 284, 285, 286, 287, 288, 289, 290, 291, 292, 293, 294, 295, 296, 297, 298, 299, 300, 301, 302, 303, 304, 305, 306, 307, 308, 309, 310, 311, 312, 313, 314, 315, 316, 317, 318, 319, 320, 321, 322, 323, 324, 325, 326, 327, 328, 329, 330, 331, 332, 333, 334, 335, 336, 337, 338, 339, 340, 341, 342, 343, 344, 345, 346, 347, 348, 349, 350, 351, 352, 353, 354, 355, 356, 357, 358, 359, 360, 361, 362, 363, 364, 365, 366, 367, 368, 369, 370, 371, 372, 373, 374, 375, 376, 377, 378, 379, 380, 381, 382, 383, 384, 385, 386, 387, 388, 389, 390, 391, 392, 393, 394, 395, 396, 397, 398, 399, 400, 401, 402, 403, 404, 405, 406, 407, 408, 409, 410, 411, 412, 413, 414, 415, 416, 417, 418, 419, 420, 421, 422, 423, 424, 425, 426, 427, 428, 429, 430, 431, 432, 433, 434, 435, 436, 437, 438, 439, 440, 441, 442, 443, 444, 445, 446, 447, 448, 449, 450, 451, 452, 453, 454, 455, 456, 457, 458, 459, 460, 461, 462, 463, 464, 465, 466, 467, 468, 469, 470, 471, 472, 473, 474, 475, 476, 477, 478, 479, 480, 481, 482, 483, 484, 485, 486, 487, 488, 489, 490, 491, 492, 493, 494, 495, 496, 497, 498, 499, 500, 501, 502, 503, 504, 505, 506, 507, 508, 509, 510, 511, 512, 513, 514, 515, 516, 517, 518, 519, 520, 521, 522, 523, 524, 525, 526, 527, 528, 529, 530, 531, 532, 533, 534, 535, 536, 537, 538, 539, 540, 541, 542, 543, 544, 545, 546, 547, 548, 549, 550, 551, 552, 553, 554, 555, 556, 557, 558, 559, 560, 561, 562, 563, 564, 565, 566, 567, 568, 569, 570, 571, 572, 573, 574, 575, 576, 577, 578, 579, 580, 581, 582, 583, 584, 585, 586, 587, 588, 589, 590, 591, 592, 593, 594, 595, 596, 597, 598, 599, 600, 601, 602, 603, 604, 605, 606, 607, 608, 609, 610, 611, 612, 613, 614, 615, 616, 617, 618, 619, 620, 621, 622, 623, 624, 625, 626, 627, 628, 629, 630, 631, 632, 633, 634, 635, 636, 637, 638, 639, 640, 641, 642, 643, 644, 645, 646, 647, 648, 649, 650, 651, 652, 653, 654, 655, 656, 657, 658, 659, 660, 661, 662, 663, 664, 665, 666, 667, 668, 669, 670, 671, 672, 673, 674, 675, 676, 677, 678, 679, 680, 681, 682, 683, 684, 685, 686, 687, 688, 689, 690, 691, 692, 693, 694, 695, 696, 697, 698, 699, 700, 701, 702, 703, 704, 705, 706, 707, 708, 709, 710, 711, 712, 713, 714, 715, 716, 717, 718, 719, 720, 721, 722, 723, 724, 725, 726, 727, 728, 729, 730, 731, 732, 733, 734, 735, 736, 737, 738, 739, 740, 741, 742, 743, 744, 745, 746, 747, 748, 749, 750, 751, 752, 753, 754, 755, 756, 757, 758, 759, 760, 761, 762, 763, 764, 765, 766, 767, 768, 769, 770, 771, 772, 773, 774, 775, 776, 777, 778, 779, 780, 781, 782, 783, 784, 785, 786, 787, 788, 789, 790, 791, 792, 793, 794, 795, 796, 797, 798, 799, 800, 801, 802, 803, 804, 805, 806, 807, 808, 809, 810, 811, 812, 813, 814, 815, 816, 817, 818, 819, 820, 821, 822, 823, 824, 825, 826, 827, 828, 829, 830, 831, 832, 833, 834, 835, 836, 837, 838, 839, 840, 841, 842, 843, 844, 845, 846, 847, 848, 849, 850, 851, 852, 853, 854, 855, 856, 857, 858, 859, 860, 861, 862, 863, 864, 865, 866, 867, 868, 869, 870, 871, 872, 873, 874, 875, 876, 877, 878, 879, 880, 881, 882, 883, 884, 885, 886, 887, 888, 889, 890, 891, 892, 893, 894, 895, 896, 897, 898, 899, 900, 901, 902, 903, 904, 905, 906, 907, 908, 909, 910, 911, 912, 913, 914, 915, 916, 917, 918, 919, 920, 921, 922, 923, 924, 925, 926, 927, 928, 929, 930, 931, 932, 933, 934, 935, 936, 937, 938, 939, 940, 941, 942, 943, 944, 945, 946, 947, 948, 949, 950, 951, 952, 953, 954, 955, 956, 957, 958, 959, 960, 961, 962, 963, 964, 965, 966, 967, 968, 969, 970, 971, 972, 973, 974, 975, 976, 977, 978, 979, 980, 981, 982, 983, 984, 985, 986, 987, 988, 989, 990, 991, 992, 993, 994, 995, 996, 997, 998, 999, 1000

MAIN CONTRACTOR :
Gammon

STRUCTURAL ENGINEER :
ARUP

FACADE CONSULTANT:
MEINHARDT

NOTE :

1. ALL DIMENSIONS ARE IN mm.
2. ALL ELEVATIONS ARE VIEWED FROM OUTSIDE.
3. ALL DIMENSIONS TO BE VERIFIED ON SITE BEFORE FABRICATION.

LEGEND :

x1 — DETAIL MARK NO.
 x001 — REFER SHEET NO.

1. F.F.L. -- FINISHED FLOOR LEVEL
2. S.F.L. -- STRUCTURAL FLOOR LEVEL
3. (R) -- REVERSED DETAIL
- (X) -- FIXING LOCATION
- (L) -- FIXING LUG LOCATION

GLASS LEGEND

GL01 -- 8mm+12mm AIR GAP+10mm THK. I.G.U.
 GL01a -- 8mm+9mm AIR GAP+12mm THK. I.G.U.
 GL03 -- 6mm+12mm AIR GAP+6mm THK. I.G.U.
 GL04 -- 10mm THK. TEMPERED GLASS (PROTECTIVE BARRIER)
 GL05 -- 6mm+12mm AIR GAP+8mm THK. I.G.U.

NO.	DATE	REVISION	BY
A	05/03/2021	REVISION SUBJECT TO ARCH.COMMENT	lvart

JOB NO. : J-852

PROJECT :
 PROPOSED RESIDENTIAL DEVELOPMENT
 AT 139 - 147 ARGYLE STREET,
 NKIL 6005, 6035 R.P., 6036 R.P.,
 6037 R.P. & 6038 R.P.

TITLE :
 DETAIL FOR
 Plenum Box

DATE : 05-Dec-19 SCALE : 1:2

DRAWN BY : MN CHECKED BY : DW

美特鋁質有限公司
MIDI ALUMINIUM FABRICATOR LTD.
 Units 6-8, Sunray Industrial Centre, 1/F
 610 Cha Kwo Ling Road, Kowloon
 Tel:23489211-4 Fax:(852)2727666

DWG NO. : J852-SD-PB-5001a REV. : A

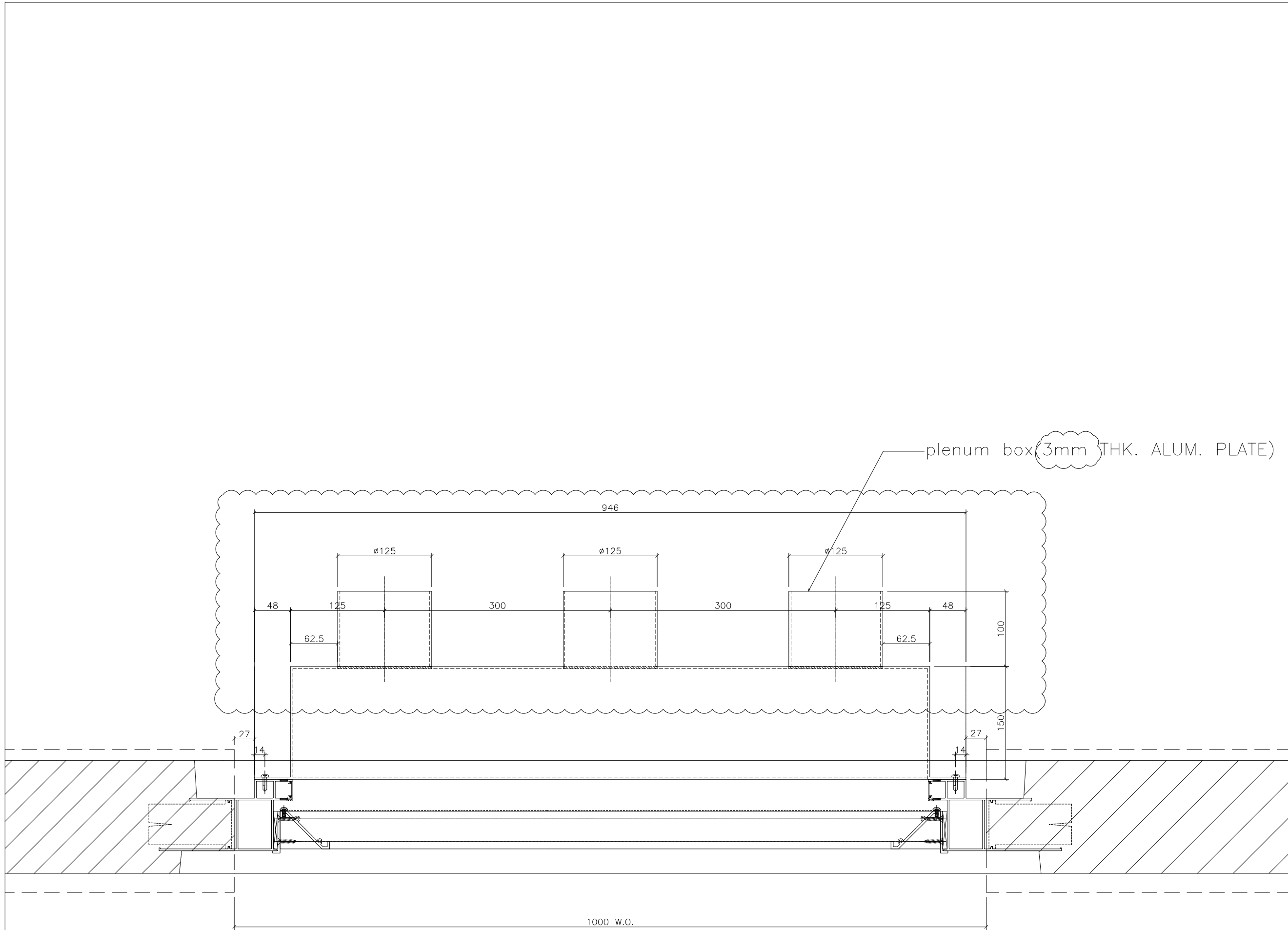

1 HORIZONTAL DETAIL OUTSIDE
SCALE 1:1

B.D. REF :

CLIENT :

ARCHITECT :
AGC DESIGN LTD
AGC DESIGN LTD
101, 102, 103, 104, 105, 106, 107, 108, 109, 110, 111, 112, 113, 114, 115, 116, 117, 118, 119, 120, 121, 122, 123, 124, 125, 126, 127, 128, 129, 130, 131, 132, 133, 134, 135, 136, 137, 138, 139, 140, 141, 142, 143, 144, 145, 146, 147, 148, 149, 150, 151, 152, 153, 154, 155, 156, 157, 158, 159, 160, 161, 162, 163, 164, 165, 166, 167, 168, 169, 170, 171, 172, 173, 174, 175, 176, 177, 178, 179, 180, 181, 182, 183, 184, 185, 186, 187, 188, 189, 190, 191, 192, 193, 194, 195, 196, 197, 198, 199, 200, 201, 202, 203, 204, 205, 206, 207, 208, 209, 210, 211, 212, 213, 214, 215, 216, 217, 218, 219, 220, 221, 222, 223, 224, 225, 226, 227, 228, 229, 230, 231, 232, 233, 234, 235, 236, 237, 238, 239, 240, 241, 242, 243, 244, 245, 246, 247, 248, 249, 250, 251, 252, 253, 254, 255, 256, 257, 258, 259, 260, 261, 262, 263, 264, 265, 266, 267, 268, 269, 270, 271, 272, 273, 274, 275, 276, 277, 278, 279, 280, 281, 282, 283, 284, 285, 286, 287, 288, 289, 290, 291, 292, 293, 294, 295, 296, 297, 298, 299, 300, 301, 302, 303, 304, 305, 306, 307, 308, 309, 310, 311, 312, 313, 314, 315, 316, 317, 318, 319, 320, 321, 322, 323, 324, 325, 326, 327, 328, 329, 330, 331, 332, 333, 334, 335, 336, 337, 338, 339, 340, 341, 342, 343, 344, 345, 346, 347, 348, 349, 350, 351, 352, 353, 354, 355, 356, 357, 358, 359, 360, 361, 362, 363, 364, 365, 366, 367, 368, 369, 370, 371, 372, 373, 374, 375, 376, 377, 378, 379, 380, 381, 382, 383, 384, 385, 386, 387, 388, 389, 390, 391, 392, 393, 394, 395, 396, 397, 398, 399, 400, 401, 402, 403, 404, 405, 406, 407, 408, 409, 410, 411, 412, 413, 414, 415, 416, 417, 418, 419, 420, 421, 422, 423, 424, 425, 426, 427, 428, 429, 430, 431, 432, 433, 434, 435, 436, 437, 438, 439, 440, 441, 442, 443, 444, 445, 446, 447, 448, 449, 450, 451, 452, 453, 454, 455, 456, 457, 458, 459, 460, 461, 462, 463, 464, 465, 466, 467, 468, 469, 470, 471, 472, 473, 474, 475, 476, 477, 478, 479, 480, 481, 482, 483, 484, 485, 486, 487, 488, 489, 490, 491, 492, 493, 494, 495, 496, 497, 498, 499, 500, 501, 502, 503, 504, 505, 506, 507, 508, 509, 510, 511, 512, 513, 514, 515, 516, 517, 518, 519, 520, 521, 522, 523, 524, 525, 526, 527, 528, 529, 530, 531, 532, 533, 534, 535, 536, 537, 538, 539, 540, 541, 542, 543, 544, 545, 546, 547, 548, 549, 550, 551, 552, 553, 554, 555, 556, 557, 558, 559, 560, 561, 562, 563, 564, 565, 566, 567, 568, 569, 570, 571, 572, 573, 574, 575, 576, 577, 578, 579, 580, 581, 582, 583, 584, 585, 586, 587, 588, 589, 590, 591, 592, 593, 594, 595, 596, 597, 598, 599, 600, 601, 602, 603, 604, 605, 606, 607, 608, 609, 610, 611, 612, 613, 614, 615, 616, 617, 618, 619, 620, 621, 622, 623, 624, 625, 626, 627, 628, 629, 630, 631, 632, 633, 634, 635, 636, 637, 638, 639, 640, 641, 642, 643, 644, 645, 646, 647, 648, 649, 650, 651, 652, 653, 654, 655, 656, 657, 658, 659, 660, 661, 662, 663, 664, 665, 666, 667, 668, 669, 670, 671, 672, 673, 674, 675, 676, 677, 678, 679, 680, 681, 682, 683, 684, 685, 686, 687, 688, 689, 690, 691, 692, 693, 694, 695, 696, 697, 698, 699, 700, 701, 702, 703, 704, 705, 706, 707, 708, 709, 710, 711, 712, 713, 714, 715, 716, 717, 718, 719, 720, 721, 722, 723, 724, 725, 726, 727, 728, 729, 730, 731, 732, 733, 734, 735, 736, 737, 738, 739, 740, 741, 742, 743, 744, 745, 746, 747, 748, 749, 750, 751, 752, 753, 754, 755, 756, 757, 758, 759, 760, 761, 762, 763, 764, 765, 766, 767, 768, 769, 770, 771, 772, 773, 774, 775, 776, 777, 778, 779, 780, 781, 782, 783, 784, 785, 786, 787, 788, 789, 790, 791, 792, 793, 794, 795, 796, 797, 798, 799, 800, 801, 802, 803, 804, 805, 806, 807, 808, 809, 810, 811, 812, 813, 814, 815, 816, 817, 818, 819, 820, 821, 822, 823, 824, 825, 826, 827, 828, 829, 830, 831, 832, 833, 834, 835, 836, 837, 838, 839, 840, 841, 842, 843, 844, 845, 846, 847, 848, 849, 850, 851, 852, 853, 854, 855, 856, 857, 858, 859, 860, 861, 862, 863, 864, 865, 866, 867, 868, 869, 870, 871, 872, 873, 874, 875, 876, 877, 878, 879, 880, 881, 882, 883, 884, 885, 886, 887, 888, 889, 890, 891, 892, 893, 894, 895, 896, 897, 898, 899, 900, 901, 902, 903, 904, 905, 906, 907, 908, 909, 910, 911, 912, 913, 914, 915, 916, 917, 918, 919, 920, 921, 922, 923, 924, 925, 926, 927, 928, 929, 930, 931, 932, 933, 934, 935, 936, 937, 938, 939, 940, 941, 942, 943, 944, 945, 946, 947, 948, 949, 950, 951, 952, 953, 954, 955, 956, 957, 958, 959, 960, 961, 962, 963, 964, 965, 966, 967, 968, 969, 970, 971, 972, 973, 974, 975, 976, 977, 978, 979, 980, 981, 982, 983, 984, 985, 986, 987, 988, 989, 990, 991, 992, 993, 994, 995, 996, 997, 998, 999, 1000

MAIN CONTRACTOR :
Gammon

STRUCTURAL ENGINEER :
ARUP

FACADE CONSULTANT:
MEINHARDT

NOTE :
1. ALL DIMENSIONS ARE IN mm.
2. ALL ELEVATIONS ARE VIEWED FROM OUTSIDE.
3. ALL DIMENSIONS TO BE VERIFIED ON SITE BEFORE FABRICATION.

LEGEND :
x1 -- DETAIL MARK NO.
x001 -- REFER SHEET NO.
1. F.F.L. -- FINISHED FLOOR LEVEL
2. S.F.L. -- STRUCTURAL FLOOR LEVEL
3. (R) -- REVERSED DETAIL
-- FIXING LOCATION
-- FIXING LUG LOCATION

GLASS LEGEND
GL01 -- 8mm+12mm AIR GAP+10mm THK. I.G.U.
GL01a -- 8mm+9mm AIR GAP+12mm THK. I.G.U.
GL03 -- 6mm+12mm AIR GAP+6mm THK. I.G.U.
GL04 -- 10mm THK. TEMPERED GLASS (PROTECTIVE BARRIER)
GL05 -- 6mm+12mm AIR GAP+8mm THK. I.G.U.

NO.	DATE	REVISION SUBJECT TO ARCH.COMMENT	BY
A	09/12/2020	REVISION SUBJECT TO ARCH.COMMENT	Ivan

JOB NO. : J-852
PROJECT : PROPOSED RESIDENTIAL DEVELOPMENT AT 139 - 147 ARGYLE STREET, NKIL 6005, 6035 R.P., 6036 R.P., 6037 R.P. & 6038 R.P.

TITLE : DETAIL FOR Plenum Box

DATE : 05-Dec-19 SCALE : 1:2

DRAWN BY : MN CHECKED BY : DW

美特鋁質有限公司
MIDI ALUMINIUM FABRICATOR LTD.
Units 6-8, Sunray Industrial Centre, 1/F
610 Cha Kwo Ling Road, Kowloon
Tel:23489211-4 Fax:(852)2727666

DWG NO. : J852-SD-PB-5002 REV. : A

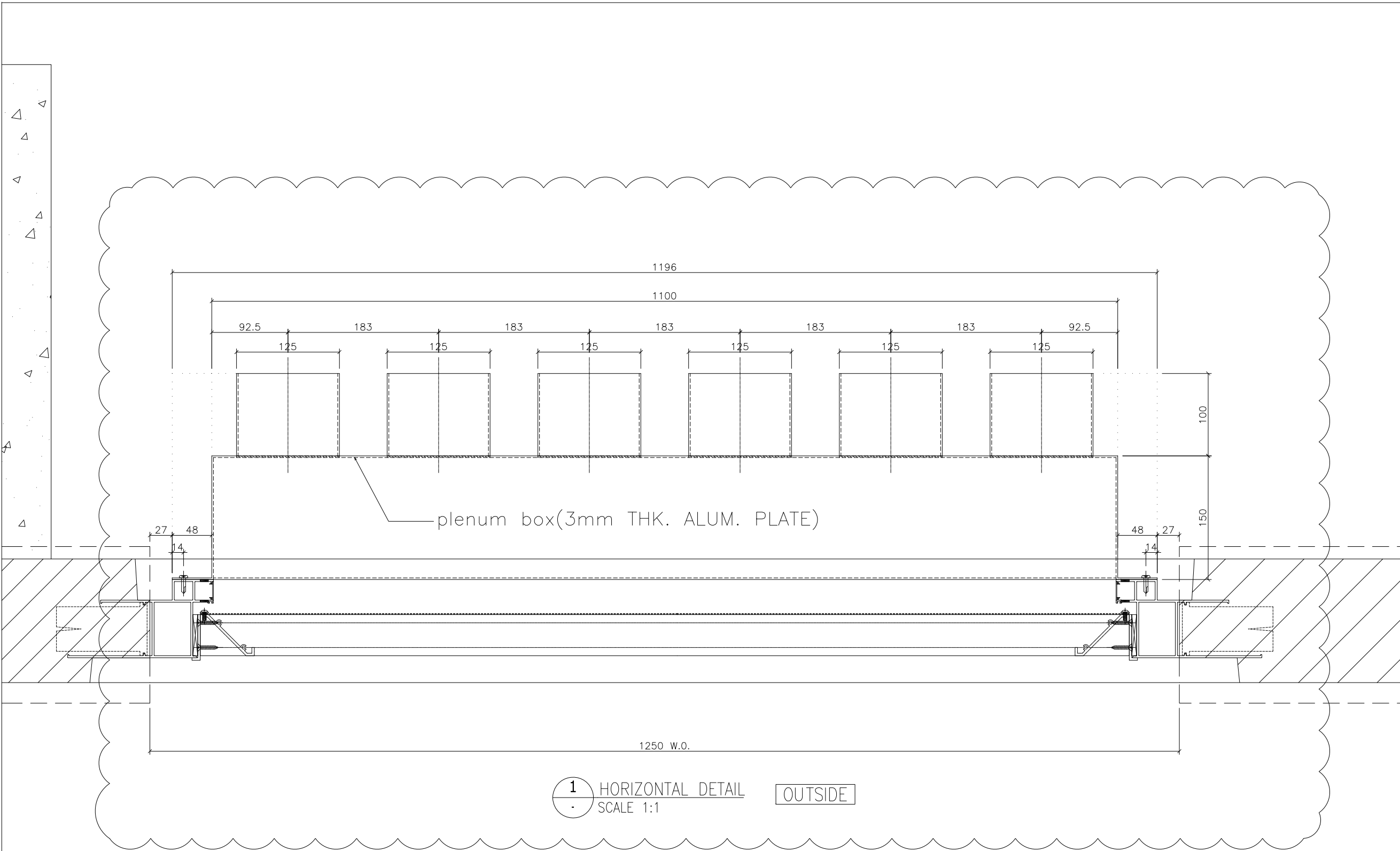

1 HORIZONTAL DETAIL
SCALE 1:1

OUTSIDE

B.D. REF :

CLIENT :

ARCHITECT :
AGC DESIGN LTD
AGC DESIGN LTD
101, 102, 103, 104, 105, 106, 107, 108, 109, 110, 111, 112, 113, 114, 115, 116, 117, 118, 119, 120, 121, 122, 123, 124, 125, 126, 127, 128, 129, 130, 131, 132, 133, 134, 135, 136, 137, 138, 139, 140, 141, 142, 143, 144, 145, 146, 147, 148, 149, 150, 151, 152, 153, 154, 155, 156, 157, 158, 159, 160, 161, 162, 163, 164, 165, 166, 167, 168, 169, 170, 171, 172, 173, 174, 175, 176, 177, 178, 179, 180, 181, 182, 183, 184, 185, 186, 187, 188, 189, 190, 191, 192, 193, 194, 195, 196, 197, 198, 199, 200, 201, 202, 203, 204, 205, 206, 207, 208, 209, 210, 211, 212, 213, 214, 215, 216, 217, 218, 219, 220, 221, 222, 223, 224, 225, 226, 227, 228, 229, 230, 231, 232, 233, 234, 235, 236, 237, 238, 239, 240, 241, 242, 243, 244, 245, 246, 247, 248, 249, 250, 251, 252, 253, 254, 255, 256, 257, 258, 259, 260, 261, 262, 263, 264, 265, 266, 267, 268, 269, 270, 271, 272, 273, 274, 275, 276, 277, 278, 279, 280, 281, 282, 283, 284, 285, 286, 287, 288, 289, 290, 291, 292, 293, 294, 295, 296, 297, 298, 299, 300, 301, 302, 303, 304, 305, 306, 307, 308, 309, 310, 311, 312, 313, 314, 315, 316, 317, 318, 319, 320, 321, 322, 323, 324, 325, 326, 327, 328, 329, 330, 331, 332, 333, 334, 335, 336, 337, 338, 339, 340, 341, 342, 343, 344, 345, 346, 347, 348, 349, 350, 351, 352, 353, 354, 355, 356, 357, 358, 359, 360, 361, 362, 363, 364, 365, 366, 367, 368, 369, 370, 371, 372, 373, 374, 375, 376, 377, 378, 379, 380, 381, 382, 383, 384, 385, 386, 387, 388, 389, 390, 391, 392, 393, 394, 395, 396, 397, 398, 399, 400, 401, 402, 403, 404, 405, 406, 407, 408, 409, 410, 411, 412, 413, 414, 415, 416, 417, 418, 419, 420, 421, 422, 423, 424, 425, 426, 427, 428, 429, 430, 431, 432, 433, 434, 435, 436, 437, 438, 439, 440, 441, 442, 443, 444, 445, 446, 447, 448, 449, 450, 451, 452, 453, 454, 455, 456, 457, 458, 459, 460, 461, 462, 463, 464, 465, 466, 467, 468, 469, 470, 471, 472, 473, 474, 475, 476, 477, 478, 479, 480, 481, 482, 483, 484, 485, 486, 487, 488, 489, 490, 491, 492, 493, 494, 495, 496, 497, 498, 499, 500, 501, 502, 503, 504, 505, 506, 507, 508, 509, 510, 511, 512, 513, 514, 515, 516, 517, 518, 519, 520, 521, 522, 523, 524, 525, 526, 527, 528, 529, 530, 531, 532, 533, 534, 535, 536, 537, 538, 539, 540, 541, 542, 543, 544, 545, 546, 547, 548, 549, 550, 551, 552, 553, 554, 555, 556, 557, 558, 559, 560, 561, 562, 563, 564, 565, 566, 567, 568, 569, 570, 571, 572, 573, 574, 575, 576, 577, 578, 579, 580, 581, 582, 583, 584, 585, 586, 587, 588, 589, 590, 591, 592, 593, 594, 595, 596, 597, 598, 599, 600, 601, 602, 603, 604, 605, 606, 607, 608, 609, 610, 611, 612, 613, 614, 615, 616, 617, 618, 619, 620, 621, 622, 623, 624, 625, 626, 627, 628, 629, 630, 631, 632, 633, 634, 635, 636, 637, 638, 639, 640, 641, 642, 643, 644, 645, 646, 647, 648, 649, 650, 651, 652, 653, 654, 655, 656, 657, 658, 659, 660, 661, 662, 663, 664, 665, 666, 667, 668, 669, 670, 671, 672, 673, 674, 675, 676, 677, 678, 679, 680, 681, 682, 683, 684, 685, 686, 687, 688, 689, 690, 691, 692, 693, 694, 695, 696, 697, 698, 699, 700, 701, 702, 703, 704, 705, 706, 707, 708, 709, 710, 711, 712, 713, 714, 715, 716, 717, 718, 719, 720, 721, 722, 723, 724, 725, 726, 727, 728, 729, 730, 731, 732, 733, 734, 735, 736, 737, 738, 739, 740, 741, 742, 743, 744, 745, 746, 747, 748, 749, 750, 751, 752, 753, 754, 755, 756, 757, 758, 759, 760, 761, 762, 763, 764, 765, 766, 767, 768, 769, 770, 771, 772, 773, 774, 775, 776, 777, 778, 779, 780, 781, 782, 783, 784, 785, 786, 787, 788, 789, 790, 791, 792, 793, 794, 795, 796, 797, 798, 799, 800, 801, 802, 803, 804, 805, 806, 807, 808, 809, 810, 811, 812, 813, 814, 815, 816, 817, 818, 819, 820, 821, 822, 823, 824, 825, 826, 827, 828, 829, 830, 831, 832, 833, 834, 835, 836, 837, 838, 839, 840, 841, 842, 843, 844, 845, 846, 847, 848, 849, 850, 851, 852, 853, 854, 855, 856, 857, 858, 859, 860, 861, 862, 863, 864, 865, 866, 867, 868, 869, 870, 871, 872, 873, 874, 875, 876, 877, 878, 879, 880, 881, 882, 883, 884, 885, 886, 887, 888, 889, 890, 891, 892, 893, 894, 895, 896, 897, 898, 899, 900, 901, 902, 903, 904, 905, 906, 907, 908, 909, 910, 911, 912, 913, 914, 915, 916, 917, 918, 919, 920, 921, 922, 923, 924, 925, 926, 927, 928, 929, 930, 931, 932, 933, 934, 935, 936, 937, 938, 939, 940, 941, 942, 943, 944, 945, 946, 947, 948, 949, 950, 951, 952, 953, 954, 955, 956, 957, 958, 959, 960, 961, 962, 963, 964, 965, 966, 967, 968, 969, 970, 971, 972, 973, 974, 975, 976, 977, 978, 979, 980, 981, 982, 983, 984, 985, 986, 987, 988, 989, 990, 991, 992, 993, 994, 995, 996, 997, 998, 999, 1000

MAIN CONTRACTOR :
Gammon

STRUCTURAL ENGINEER :
ARUP

FAÇADE CONSULTANT:
MEINHARDT

NOTE :
1. ALL DIMENSIONS ARE IN mm.
2. ALL ELEVATIONS ARE VIEWED FROM OUTSIDE.
3. ALL DIMENSIONS TO BE VERIFIED ON SITE BEFORE FABRICATION.

LEGEND :
x1 -- DETAIL MARK NO.
x001 -- REFER SHEET NO.
1. F.F.L. -- FINISHED FLOOR LEVEL
2. S.F.L. -- STRUCTURAL FLOOR LEVEL
3. (R) -- REVERSED DETAIL
-- FIXING LOCATION
-- FIXING LUG LOCATION

GLASS LEGEND
GL01 -- 8mm+12mm AIR GAP+10mm THK. I.G.U.
GL01a -- 8mm+9mm AIR GAP+12mm THK. I.G.U.
GL03 -- 6mm+12mm AIR GAP+6mm THK. I.G.U.
GL04 -- 10mm THK. TEMPERED GLASS (PROTECTIVE BARRIER)
GL05 -- 6mm+12mm AIR GAP+8mm THK. I.G.U.

NO.	DATE	REVISION	BY
A	06/01/2021	REVISION SUBJECT TO ARCH.COMMENT	lvn

JOB NO. : J-852
PROJECT :
PROPOSED RESIDENTIAL DEVELOPMENT
AT 139 - 147 ARGYLE STREET,
NKIL 6005, 6035 R.P., 6036 R.P.,
6037 R.P. & 6038 R.P.

TITLE :
DETAIL FOR
Plenum Box

DATE : 05-Dec-19 SCALE : 1:2

DRAWN BY : MN CHECKED BY : DW

美特鋁質有限公司
MIDI ALUMINIUM FABRICATOR LTD.
Units 6-8, Sunray Industrial Centre, 1/F
610 Cha Kwo Ling Road, Kowloon
Tel:23489211-4 Fax:(852)2727666

DWG NO. : J852-SD-PB-5002a REV. : A

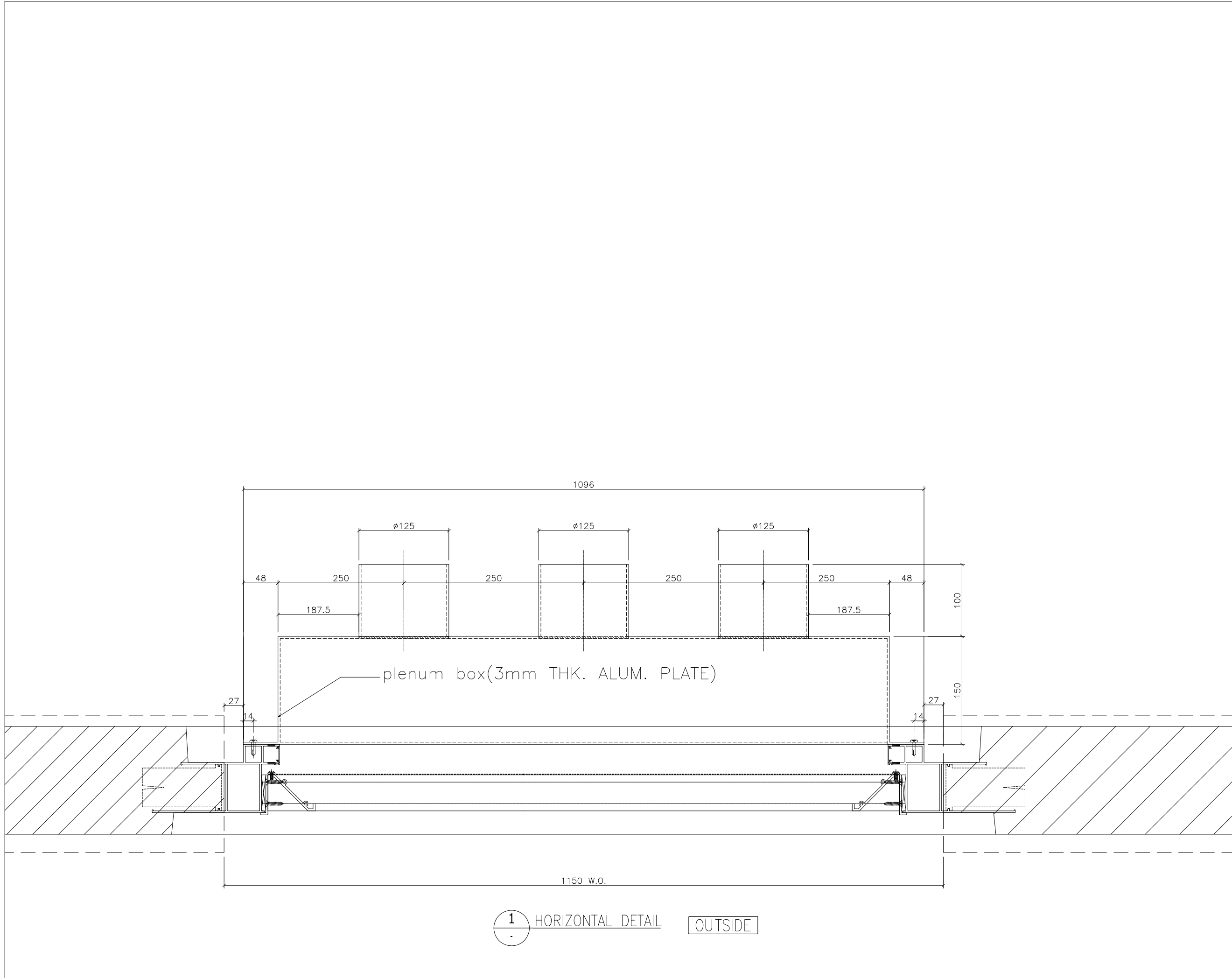

1 HORIZONTAL DETAIL OUTSIDE

B.D. REF :

CLIENT :

ARCHITECT :
AGC DESIGN LTD
 101, 102, 103, 104, 105, 106, 107, 108, 109, 110, 111, 112, 113, 114, 115, 116, 117, 118, 119, 120, 121, 122, 123, 124, 125, 126, 127, 128, 129, 130, 131, 132, 133, 134, 135, 136, 137, 138, 139, 140, 141, 142, 143, 144, 145, 146, 147, 148, 149, 150, 151, 152, 153, 154, 155, 156, 157, 158, 159, 160, 161, 162, 163, 164, 165, 166, 167, 168, 169, 170, 171, 172, 173, 174, 175, 176, 177, 178, 179, 180, 181, 182, 183, 184, 185, 186, 187, 188, 189, 190, 191, 192, 193, 194, 195, 196, 197, 198, 199, 200, 201, 202, 203, 204, 205, 206, 207, 208, 209, 210, 211, 212, 213, 214, 215, 216, 217, 218, 219, 220, 221, 222, 223, 224, 225, 226, 227, 228, 229, 230, 231, 232, 233, 234, 235, 236, 237, 238, 239, 240, 241, 242, 243, 244, 245, 246, 247, 248, 249, 250, 251, 252, 253, 254, 255, 256, 257, 258, 259, 260, 261, 262, 263, 264, 265, 266, 267, 268, 269, 270, 271, 272, 273, 274, 275, 276, 277, 278, 279, 280, 281, 282, 283, 284, 285, 286, 287, 288, 289, 290, 291, 292, 293, 294, 295, 296, 297, 298, 299, 300, 301, 302, 303, 304, 305, 306, 307, 308, 309, 310, 311, 312, 313, 314, 315, 316, 317, 318, 319, 320, 321, 322, 323, 324, 325, 326, 327, 328, 329, 330, 331, 332, 333, 334, 335, 336, 337, 338, 339, 340, 341, 342, 343, 344, 345, 346, 347, 348, 349, 350, 351, 352, 353, 354, 355, 356, 357, 358, 359, 360, 361, 362, 363, 364, 365, 366, 367, 368, 369, 370, 371, 372, 373, 374, 375, 376, 377, 378, 379, 380, 381, 382, 383, 384, 385, 386, 387, 388, 389, 390, 391, 392, 393, 394, 395, 396, 397, 398, 399, 400, 401, 402, 403, 404, 405, 406, 407, 408, 409, 410, 411, 412, 413, 414, 415, 416, 417, 418, 419, 420, 421, 422, 423, 424, 425, 426, 427, 428, 429, 430, 431, 432, 433, 434, 435, 436, 437, 438, 439, 440, 441, 442, 443, 444, 445, 446, 447, 448, 449, 450, 451, 452, 453, 454, 455, 456, 457, 458, 459, 460, 461, 462, 463, 464, 465, 466, 467, 468, 469, 470, 471, 472, 473, 474, 475, 476, 477, 478, 479, 480, 481, 482, 483, 484, 485, 486, 487, 488, 489, 490, 491, 492, 493, 494, 495, 496, 497, 498, 499, 500, 501, 502, 503, 504, 505, 506, 507, 508, 509, 510, 511, 512, 513, 514, 515, 516, 517, 518, 519, 520, 521, 522, 523, 524, 525, 526, 527, 528, 529, 530, 531, 532, 533, 534, 535, 536, 537, 538, 539, 540, 541, 542, 543, 544, 545, 546, 547, 548, 549, 550, 551, 552, 553, 554, 555, 556, 557, 558, 559, 560, 561, 562, 563, 564, 565, 566, 567, 568, 569, 570, 571, 572, 573, 574, 575, 576, 577, 578, 579, 580, 581, 582, 583, 584, 585, 586, 587, 588, 589, 590, 591, 592, 593, 594, 595, 596, 597, 598, 599, 600, 601, 602, 603, 604, 605, 606, 607, 608, 609, 610, 611, 612, 613, 614, 615, 616, 617, 618, 619, 620, 621, 622, 623, 624, 625, 626, 627, 628, 629, 630, 631, 632, 633, 634, 635, 636, 637, 638, 639, 640, 641, 642, 643, 644, 645, 646, 647, 648, 649, 650, 651, 652, 653, 654, 655, 656, 657, 658, 659, 660, 661, 662, 663, 664, 665, 666, 667, 668, 669, 670, 671, 672, 673, 674, 675, 676, 677, 678, 679, 680, 681, 682, 683, 684, 685, 686, 687, 688, 689, 690, 691, 692, 693, 694, 695, 696, 697, 698, 699, 700, 701, 702, 703, 704, 705, 706, 707, 708, 709, 710, 711, 712, 713, 714, 715, 716, 717, 718, 719, 720, 721, 722, 723, 724, 725, 726, 727, 728, 729, 730, 731, 732, 733, 734, 735, 736, 737, 738, 739, 740, 741, 742, 743, 744, 745, 746, 747, 748, 749, 750, 751, 752, 753, 754, 755, 756, 757, 758, 759, 760, 761, 762, 763, 764, 765, 766, 767, 768, 769, 770, 771, 772, 773, 774, 775, 776, 777, 778, 779, 780, 781, 782, 783, 784, 785, 786, 787, 788, 789, 790, 791, 792, 793, 794, 795, 796, 797, 798, 799, 800, 801, 802, 803, 804, 805, 806, 807, 808, 809, 810, 811, 812, 813, 814, 815, 816, 817, 818, 819, 820, 821, 822, 823, 824, 825, 826, 827, 828, 829, 830, 831, 832, 833, 834, 835, 836, 837, 838, 839, 840, 841, 842, 843, 844, 845, 846, 847, 848, 849, 850, 851, 852, 853, 854, 855, 856, 857, 858, 859, 860, 861, 862, 863, 864, 865, 866, 867, 868, 869, 870, 871, 872, 873, 874, 875, 876, 877, 878, 879, 880, 881, 882, 883, 884, 885, 886, 887, 888, 889, 890, 891, 892, 893, 894, 895, 896, 897, 898, 899, 900, 901, 902, 903, 904, 905, 906, 907, 908, 909, 910, 911, 912, 913, 914, 915, 916, 917, 918, 919, 920, 921, 922, 923, 924, 925, 926, 927, 928, 929, 930, 931, 932, 933, 934, 935, 936, 937, 938, 939, 940, 941, 942, 943, 944, 945, 946, 947, 948, 949, 950, 951, 952, 953, 954, 955, 956, 957, 958, 959, 960, 961, 962, 963, 964, 965, 966, 967, 968, 969, 970, 971, 972, 973, 974, 975, 976, 977, 978, 979, 980, 981, 982, 983, 984, 985, 986, 987, 988, 989, 990, 991, 992, 993, 994, 995, 996, 997, 998, 999, 1000

MAIN CONTRACTOR :
Gammon

STRUCTURAL ENGINEER :
ARUP

FACADE CONSULTANT:
MEINHARDT

NOTE :
 1. ALL DIMENSIONS ARE IN mm.
 2. ALL ELEVATIONS ARE VIEWED FROM OUTSIDE.
 3. ALL DIMENSIONS TO BE VERIFIED ON SITE BEFORE FABRICATION.

LEGEND :
 (x1) — DETAIL MARK NO.
 (x001) — REFER SHEET NO.

1. F.F.L. -- FINISHED FLOOR LEVEL
 2. S.F.L. -- STRUCTURAL FLOOR LEVEL
 3. (R) -- REVERSED DETAIL
 -- FIXING LOCATION
 -- FIXING LUG LOCATION

GLASS LEGEND
 GL01 -- 8mm+12mm AIR GAP+10mm THK. I.G.U.
 GL01a -- 8mm+9mm AIR GAP+12mm THK. I.G.U.
 GL03 -- 6mm+12mm AIR GAP+6mm THK. I.G.U.
 GL04 -- 10mm THK. TEMPERED GLASS (PROTECTIVE BARRIER)
 GL05 -- 6mm+12mm AIR GAP+8mm THK. I.G.U.

NO.	DATE	REVISED	BY
-----	------	---------	----

JOB NO. : J-852
 PROJECT : PROPOSED RESIDENTIAL DEVELOPMENT AT 139 - 147 ARGYLE STREET, NKIL 6005, 6035 R.P., 6036 R.P., 6037 R.P. & 6038 R.P.

TITLE : DETAIL FOR Plenum Box

DATE : 05-Dec-19 SCALE : 1:2

DRAWN BY : MN CHECKED BY : DW

美特鋁質有限公司
MIDI ALUMINIUM FABRICATOR LTD.
 Units 6-8, Sunray Industrial Centre, 1/F
 610 Cha Kwo Ling Road, Kowloon
 Tel:23489211-4 Fax:(852)2727666

DWG NO. : J852-SD-PB-5002b REV. : -

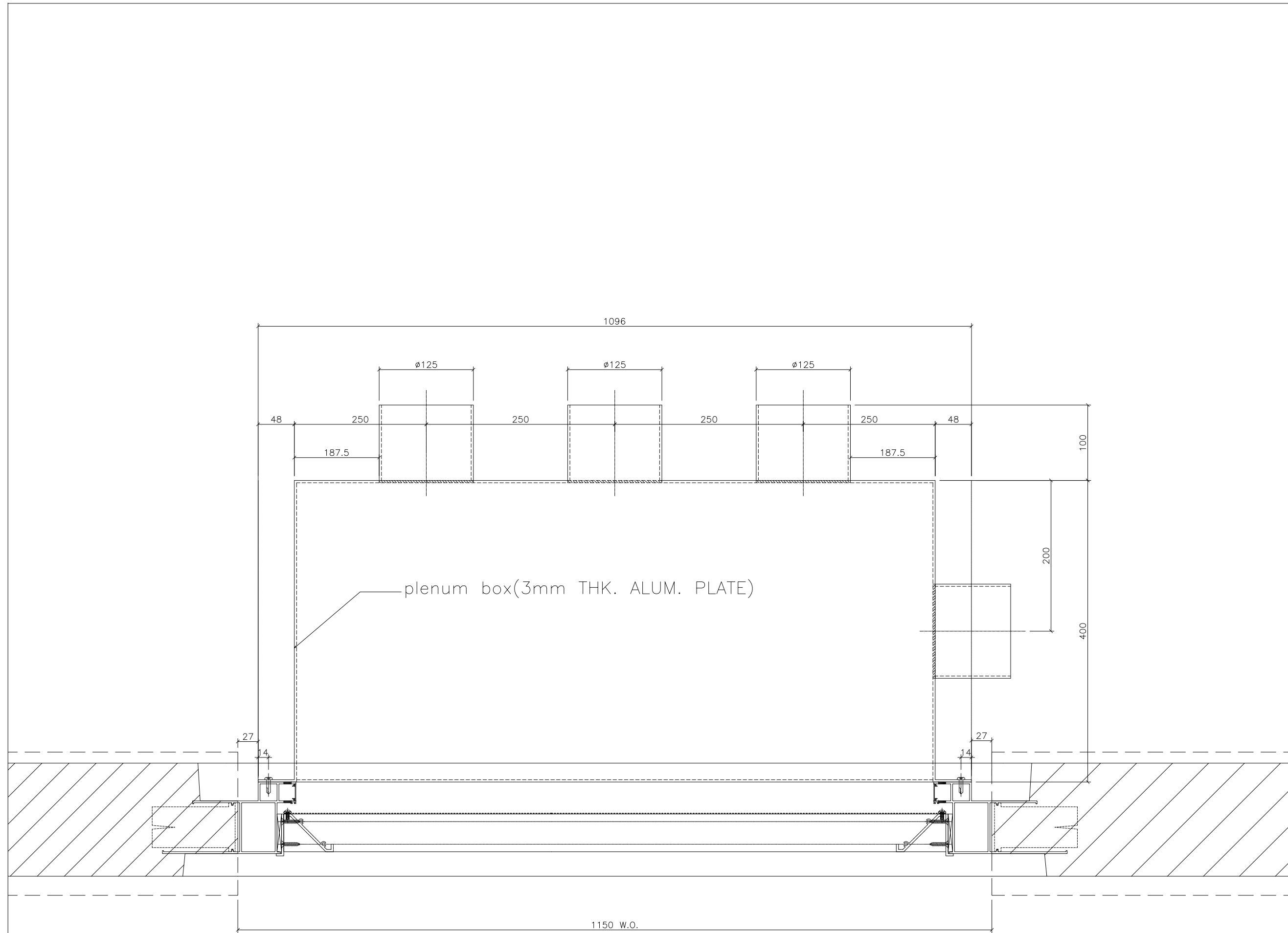

1 HORIZONTAL DETAIL OUTSIDE
SCALE 1:2

B.D. REF :

CLIENT :

ARCHITECT :
AGC DESIGN LTD
AGC DESIGN LTD
101, 102, 103, 104, 105, 106, 107, 108, 109, 110, 111, 112, 113, 114, 115, 116, 117, 118, 119, 120, 121, 122, 123, 124, 125, 126, 127, 128, 129, 130, 131, 132, 133, 134, 135, 136, 137, 138, 139, 140, 141, 142, 143, 144, 145, 146, 147, 148, 149, 150, 151, 152, 153, 154, 155, 156, 157, 158, 159, 160, 161, 162, 163, 164, 165, 166, 167, 168, 169, 170, 171, 172, 173, 174, 175, 176, 177, 178, 179, 180, 181, 182, 183, 184, 185, 186, 187, 188, 189, 190, 191, 192, 193, 194, 195, 196, 197, 198, 199, 200, 201, 202, 203, 204, 205, 206, 207, 208, 209, 210, 211, 212, 213, 214, 215, 216, 217, 218, 219, 220, 221, 222, 223, 224, 225, 226, 227, 228, 229, 230, 231, 232, 233, 234, 235, 236, 237, 238, 239, 240, 241, 242, 243, 244, 245, 246, 247, 248, 249, 250, 251, 252, 253, 254, 255, 256, 257, 258, 259, 260, 261, 262, 263, 264, 265, 266, 267, 268, 269, 270, 271, 272, 273, 274, 275, 276, 277, 278, 279, 280, 281, 282, 283, 284, 285, 286, 287, 288, 289, 290, 291, 292, 293, 294, 295, 296, 297, 298, 299, 300, 301, 302, 303, 304, 305, 306, 307, 308, 309, 310, 311, 312, 313, 314, 315, 316, 317, 318, 319, 320, 321, 322, 323, 324, 325, 326, 327, 328, 329, 330, 331, 332, 333, 334, 335, 336, 337, 338, 339, 340, 341, 342, 343, 344, 345, 346, 347, 348, 349, 350, 351, 352, 353, 354, 355, 356, 357, 358, 359, 360, 361, 362, 363, 364, 365, 366, 367, 368, 369, 370, 371, 372, 373, 374, 375, 376, 377, 378, 379, 380, 381, 382, 383, 384, 385, 386, 387, 388, 389, 390, 391, 392, 393, 394, 395, 396, 397, 398, 399, 400, 401, 402, 403, 404, 405, 406, 407, 408, 409, 410, 411, 412, 413, 414, 415, 416, 417, 418, 419, 420, 421, 422, 423, 424, 425, 426, 427, 428, 429, 430, 431, 432, 433, 434, 435, 436, 437, 438, 439, 440, 441, 442, 443, 444, 445, 446, 447, 448, 449, 450, 451, 452, 453, 454, 455, 456, 457, 458, 459, 460, 461, 462, 463, 464, 465, 466, 467, 468, 469, 470, 471, 472, 473, 474, 475, 476, 477, 478, 479, 480, 481, 482, 483, 484, 485, 486, 487, 488, 489, 490, 491, 492, 493, 494, 495, 496, 497, 498, 499, 500, 501, 502, 503, 504, 505, 506, 507, 508, 509, 510, 511, 512, 513, 514, 515, 516, 517, 518, 519, 520, 521, 522, 523, 524, 525, 526, 527, 528, 529, 530, 531, 532, 533, 534, 535, 536, 537, 538, 539, 540, 541, 542, 543, 544, 545, 546, 547, 548, 549, 550, 551, 552, 553, 554, 555, 556, 557, 558, 559, 560, 561, 562, 563, 564, 565, 566, 567, 568, 569, 570, 571, 572, 573, 574, 575, 576, 577, 578, 579, 580, 581, 582, 583, 584, 585, 586, 587, 588, 589, 590, 591, 592, 593, 594, 595, 596, 597, 598, 599, 600, 601, 602, 603, 604, 605, 606, 607, 608, 609, 610, 611, 612, 613, 614, 615, 616, 617, 618, 619, 620, 621, 622, 623, 624, 625, 626, 627, 628, 629, 630, 631, 632, 633, 634, 635, 636, 637, 638, 639, 640, 641, 642, 643, 644, 645, 646, 647, 648, 649, 650, 651, 652, 653, 654, 655, 656, 657, 658, 659, 660, 661, 662, 663, 664, 665, 666, 667, 668, 669, 670, 671, 672, 673, 674, 675, 676, 677, 678, 679, 680, 681, 682, 683, 684, 685, 686, 687, 688, 689, 690, 691, 692, 693, 694, 695, 696, 697, 698, 699, 700, 701, 702, 703, 704, 705, 706, 707, 708, 709, 710, 711, 712, 713, 714, 715, 716, 717, 718, 719, 720, 721, 722, 723, 724, 725, 726, 727, 728, 729, 730, 731, 732, 733, 734, 735, 736, 737, 738, 739, 740, 741, 742, 743, 744, 745, 746, 747, 748, 749, 750, 751, 752, 753, 754, 755, 756, 757, 758, 759, 760, 761, 762, 763, 764, 765, 766, 767, 768, 769, 770, 771, 772, 773, 774, 775, 776, 777, 778, 779, 780, 781, 782, 783, 784, 785, 786, 787, 788, 789, 790, 791, 792, 793, 794, 795, 796, 797, 798, 799, 800, 801, 802, 803, 804, 805, 806, 807, 808, 809, 810, 811, 812, 813, 814, 815, 816, 817, 818, 819, 820, 821, 822, 823, 824, 825, 826, 827, 828, 829, 830, 831, 832, 833, 834, 835, 836, 837, 838, 839, 840, 841, 842, 843, 844, 845, 846, 847, 848, 849, 850, 851, 852, 853, 854, 855, 856, 857, 858, 859, 860, 861, 862, 863, 864, 865, 866, 867, 868, 869, 870, 871, 872, 873, 874, 875, 876, 877, 878, 879, 880, 881, 882, 883, 884, 885, 886, 887, 888, 889, 890, 891, 892, 893, 894, 895, 896, 897, 898, 899, 900, 901, 902, 903, 904, 905, 906, 907, 908, 909, 910, 911, 912, 913, 914, 915, 916, 917, 918, 919, 920, 921, 922, 923, 924, 925, 926, 927, 928, 929, 930, 931, 932, 933, 934, 935, 936, 937, 938, 939, 940, 941, 942, 943, 944, 945, 946, 947, 948, 949, 950, 951, 952, 953, 954, 955, 956, 957, 958, 959, 960, 961, 962, 963, 964, 965, 966, 967, 968, 969, 970, 971, 972, 973, 974, 975, 976, 977, 978, 979, 980, 981, 982, 983, 984, 985, 986, 987, 988, 989, 990, 991, 992, 993, 994, 995, 996, 997, 998, 999, 1000

MAIN CONTRACTOR :
Gammon

STRUCTURAL ENGINEER :
ARUP

FAÇADE CONSULTANT:
MEINHARDT

NOTE :
1. ALL DIMENSIONS ARE IN mm.
2. ALL ELEVATIONS ARE VIEWED FROM OUTSIDE.
3. ALL DIMENSIONS TO BE VERIFIED ON SITE BEFORE FABRICATION.

LEGEND :
x1 — DETAIL MARK NO.
x001 — REFER SHEET NO.
1. F.F.L. -- FINISHED FLOOR LEVEL
2. S.F.L. -- STRUCTURAL FLOOR LEVEL
3. (R) -- REVERSED DETAIL
-- FIXING LOCATION
-- FIXING LUG LOCATION

GLASS LEGEND
GL01 -- 8mm+12mm AIR GAP+10mm THK. I.G.U.
GL01a -- 8mm+9mm AIR GAP+12mm THK. I.G.U.
GL03 -- 6mm+12mm AIR GAP+6mm THK. I.G.U.
GL04 -- 10mm THK. TEMPERED GLASS (PROTECTIVE BARRIER)
GL05 -- 6mm+12mm AIR GAP+8mm THK. I.G.U.

NO.	DATE	REVISED	BY
-----	------	---------	----

JOB NO. : J-852
PROJECT : PROPOSED RESIDENTIAL DEVELOPMENT AT 139 - 147 ARGYLE STREET, NKIL 6005, 6035 R.P., 6036 R.P., 6037 R.P. & 6038 R.P.

TITLE : DETAIL FOR Plenum Box

DATE : 05-Dec-19 SCALE : 1:2

DRAWN BY : MN CHECKED BY : DW

美特鋁質有限公司
MIDI ALUMINIUM FABRICATOR LTD.
Units 6-8, Sunray Industrial Centre, 1/F
610 Cha Kwo Ling Road, Kowloon
Tel:23489211-4 Fax:(852)2727666

DWG NO. : J852-SD-PB-5002c REV. : -

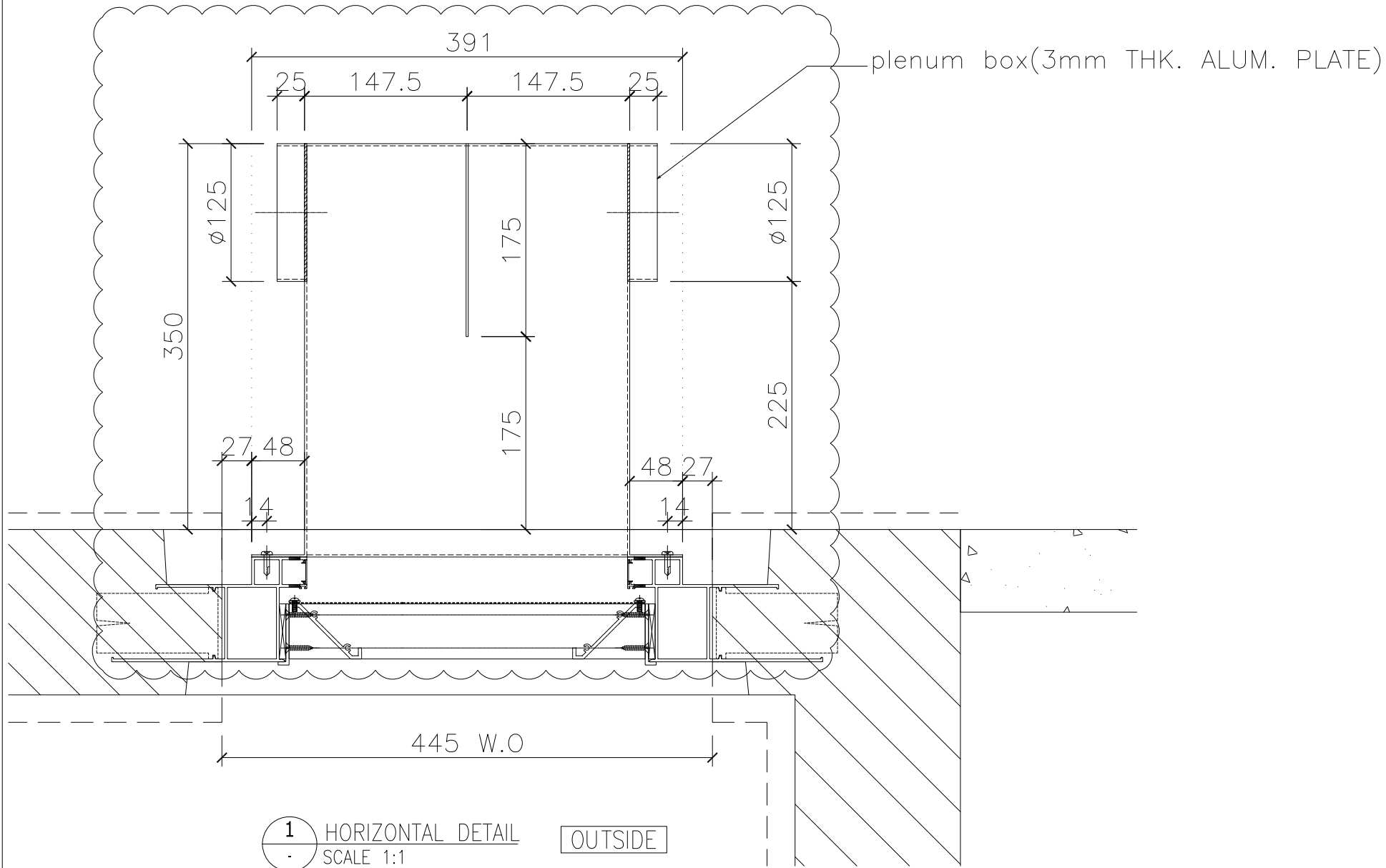

B.D. REF :

CLIENT :

ARCHITECT :
AGC DESIGN LTD
 181, 182, 183, 184, 185, 186, 187, 188, 189, 190, 191, 192, 193, 194, 195, 196, 197, 198, 199, 200, 201, 202, 203, 204, 205, 206, 207, 208, 209, 210, 211, 212, 213, 214, 215, 216, 217, 218, 219, 220, 221, 222, 223, 224, 225, 226, 227, 228, 229, 230, 231, 232, 233, 234, 235, 236, 237, 238, 239, 240, 241, 242, 243, 244, 245, 246, 247, 248, 249, 250, 251, 252, 253, 254, 255, 256, 257, 258, 259, 260, 261, 262, 263, 264, 265, 266, 267, 268, 269, 270, 271, 272, 273, 274, 275, 276, 277, 278, 279, 280, 281, 282, 283, 284, 285, 286, 287, 288, 289, 290, 291, 292, 293, 294, 295, 296, 297, 298, 299, 300, 301, 302, 303, 304, 305, 306, 307, 308, 309, 310, 311, 312, 313, 314, 315, 316, 317, 318, 319, 320, 321, 322, 323, 324, 325, 326, 327, 328, 329, 330, 331, 332, 333, 334, 335, 336, 337, 338, 339, 340, 341, 342, 343, 344, 345, 346, 347, 348, 349, 350, 351, 352, 353, 354, 355, 356, 357, 358, 359, 360, 361, 362, 363, 364, 365, 366, 367, 368, 369, 370, 371, 372, 373, 374, 375, 376, 377, 378, 379, 380, 381, 382, 383, 384, 385, 386, 387, 388, 389, 390, 391, 392, 393, 394, 395, 396, 397, 398, 399, 400, 401, 402, 403, 404, 405, 406, 407, 408, 409, 410, 411, 412, 413, 414, 415, 416, 417, 418, 419, 420, 421, 422, 423, 424, 425, 426, 427, 428, 429, 430, 431, 432, 433, 434, 435, 436, 437, 438, 439, 440, 441, 442, 443, 444, 445, 446, 447, 448, 449, 450, 451, 452, 453, 454, 455, 456, 457, 458, 459, 460, 461, 462, 463, 464, 465, 466, 467, 468, 469, 470, 471, 472, 473, 474, 475, 476, 477, 478, 479, 480, 481, 482, 483, 484, 485, 486, 487, 488, 489, 490, 491, 492, 493, 494, 495, 496, 497, 498, 499, 500, 501, 502, 503, 504, 505, 506, 507, 508, 509, 510, 511, 512, 513, 514, 515, 516, 517, 518, 519, 520, 521, 522, 523, 524, 525, 526, 527, 528, 529, 530, 531, 532, 533, 534, 535, 536, 537, 538, 539, 540, 541, 542, 543, 544, 545, 546, 547, 548, 549, 550, 551, 552, 553, 554, 555, 556, 557, 558, 559, 560, 561, 562, 563, 564, 565, 566, 567, 568, 569, 570, 571, 572, 573, 574, 575, 576, 577, 578, 579, 580, 581, 582, 583, 584, 585, 586, 587, 588, 589, 590, 591, 592, 593, 594, 595, 596, 597, 598, 599, 600, 601, 602, 603, 604, 605, 606, 607, 608, 609, 610, 611, 612, 613, 614, 615, 616, 617, 618, 619, 620, 621, 622, 623, 624, 625, 626, 627, 628, 629, 630, 631, 632, 633, 634, 635, 636, 637, 638, 639, 640, 641, 642, 643, 644, 645, 646, 647, 648, 649, 650, 651, 652, 653, 654, 655, 656, 657, 658, 659, 660, 661, 662, 663, 664, 665, 666, 667, 668, 669, 670, 671, 672, 673, 674, 675, 676, 677, 678, 679, 680, 681, 682, 683, 684, 685, 686, 687, 688, 689, 690, 691, 692, 693, 694, 695, 696, 697, 698, 699, 700, 701, 702, 703, 704, 705, 706, 707, 708, 709, 710, 711, 712, 713, 714, 715, 716, 717, 718, 719, 720, 721, 722, 723, 724, 725, 726, 727, 728, 729, 730, 731, 732, 733, 734, 735, 736, 737, 738, 739, 740, 741, 742, 743, 744, 745, 746, 747, 748, 749, 750, 751, 752, 753, 754, 755, 756, 757, 758, 759, 760, 761, 762, 763, 764, 765, 766, 767, 768, 769, 770, 771, 772, 773, 774, 775, 776, 777, 778, 779, 780, 781, 782, 783, 784, 785, 786, 787, 788, 789, 790, 791, 792, 793, 794, 795, 796, 797, 798, 799, 800, 801, 802, 803, 804, 805, 806, 807, 808, 809, 810, 811, 812, 813, 814, 815, 816, 817, 818, 819, 820, 821, 822, 823, 824, 825, 826, 827, 828, 829, 830, 831, 832, 833, 834, 835, 836, 837, 838, 839, 840, 841, 842, 843, 844, 845, 846, 847, 848, 849, 850, 851, 852, 853, 854, 855, 856, 857, 858, 859, 860, 861, 862, 863, 864, 865, 866, 867, 868, 869, 870, 871, 872, 873, 874, 875, 876, 877, 878, 879, 880, 881, 882, 883, 884, 885, 886, 887, 888, 889, 890, 891, 892, 893, 894, 895, 896, 897, 898, 899, 900, 901, 902, 903, 904, 905, 906, 907, 908, 909, 910, 911, 912, 913, 914, 915, 916, 917, 918, 919, 920, 921, 922, 923, 924, 925, 926, 927, 928, 929, 930, 931, 932, 933, 934, 935, 936, 937, 938, 939, 940, 941, 942, 943, 944, 945, 946, 947, 948, 949, 950, 951, 952, 953, 954, 955, 956, 957, 958, 959, 960, 961, 962, 963, 964, 965, 966, 967, 968, 969, 970, 971, 972, 973, 974, 975, 976, 977, 978, 979, 980, 981, 982, 983, 984, 985, 986, 987, 988, 989, 990, 991, 992, 993, 994, 995, 996, 997, 998, 999, 1000

MAIN CONTRACTOR :
Gammon

STRUCTURAL ENGINEER :
ARUP

FACADE CONSULTANT:
MEINHARDT

NOTE :

1. ALL DIMENSIONS ARE IN mm.
2. ALL ELEVATIONS ARE VIEWED FROM OUTSIDE.
3. ALL DIMENSIONS TO BE VERIFIED ON SITE BEFORE FABRICATION.

LEGEND :

(x1) — DETAIL MARK NO.
 (x001) — REFER SHEET NO.

1. F.F.L. -- FINISHED FLOOR LEVEL
2. S.F.L. -- STRUCTURAL FLOOR LEVEL
3. (R) -- REVERSED DETAIL
- (X) -- FIXING LOCATION
- (L) -- FIXING LUG LOCATION

GLASS LEGEND

GL01 -- 8mm+12mm AIR GAP+10mm THK. I.G.U.
 GL01a -- 8mm+9mm AIR GAP+12mm THK. I.G.U.
 GL03 -- 6mm+12mm AIR GAP+6mm THK. I.G.U.
 GL04 -- 10mm THK. TEMPERED GLASS (PROTECTIVE BARRIER)
 GL05 -- 6mm+12mm AIR GAP+8mm THK. I.G.U.

NO.	DATE	REVISED	BY
C	22/03/2021	REVISION SUBJECT TO ARCH.COMMENT	Ivan
B	06/01/2021	REVISION SUBJECT TO ARCH.COMMENT	Ivan
A	09/12/2020	REVISION SUBJECT TO ARCH.COMMENT	Ivan

JOB NO. : J-852

PROJECT :
 PROPOSED RESIDENTIAL DEVELOPMENT
 AT 139 - 147 ARGYLE STREET,
 NKIL 6005, 6035 R.P., 6036 R.P.,
 6037 R.P. & 6038 R.P.

TITLE :
 DETAIL FOR
 Plenum Box

DATE : 05-Dec-19 SCALE : 1:2

DRAWN BY : MN CHECKED BY : DW

美特鋁質有限公司
MIDI ALUMINIUM FABRICATOR LTD.
 Units 6-8, Sunray Industrial Centre, 1/F
 610 Cha Kwo Ling Road, Kowloon
 Tel:23489211-4 Fax:(852)2727666

DWG NO. : J852-SD-PB-5003 REV. : C

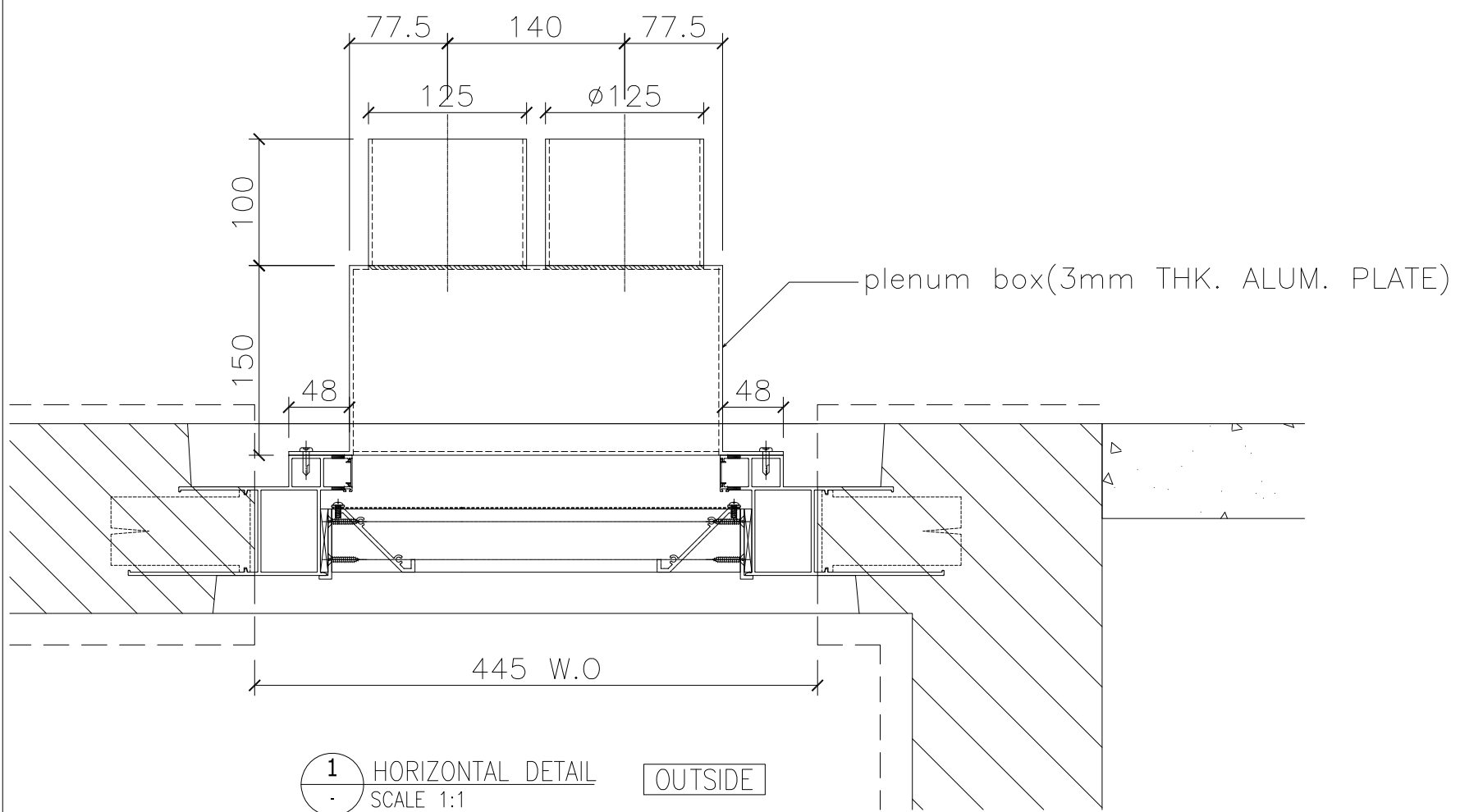

B.D. REF :

CLIENT :

ARCHITECT :
AGC DESIGN LTD
 101, 102, 103, 104, 105, 106, 107, 108, 109, 110, 111, 112, 113, 114, 115, 116, 117, 118, 119, 120, 121, 122, 123, 124, 125, 126, 127, 128, 129, 130, 131, 132, 133, 134, 135, 136, 137, 138, 139, 140, 141, 142, 143, 144, 145, 146, 147, 148, 149, 150, 151, 152, 153, 154, 155, 156, 157, 158, 159, 160, 161, 162, 163, 164, 165, 166, 167, 168, 169, 170, 171, 172, 173, 174, 175, 176, 177, 178, 179, 180, 181, 182, 183, 184, 185, 186, 187, 188, 189, 190, 191, 192, 193, 194, 195, 196, 197, 198, 199, 200, 201, 202, 203, 204, 205, 206, 207, 208, 209, 210, 211, 212, 213, 214, 215, 216, 217, 218, 219, 220, 221, 222, 223, 224, 225, 226, 227, 228, 229, 230, 231, 232, 233, 234, 235, 236, 237, 238, 239, 240, 241, 242, 243, 244, 245, 246, 247, 248, 249, 250, 251, 252, 253, 254, 255, 256, 257, 258, 259, 260, 261, 262, 263, 264, 265, 266, 267, 268, 269, 270, 271, 272, 273, 274, 275, 276, 277, 278, 279, 280, 281, 282, 283, 284, 285, 286, 287, 288, 289, 290, 291, 292, 293, 294, 295, 296, 297, 298, 299, 300, 301, 302, 303, 304, 305, 306, 307, 308, 309, 310, 311, 312, 313, 314, 315, 316, 317, 318, 319, 320, 321, 322, 323, 324, 325, 326, 327, 328, 329, 330, 331, 332, 333, 334, 335, 336, 337, 338, 339, 340, 341, 342, 343, 344, 345, 346, 347, 348, 349, 350, 351, 352, 353, 354, 355, 356, 357, 358, 359, 360, 361, 362, 363, 364, 365, 366, 367, 368, 369, 370, 371, 372, 373, 374, 375, 376, 377, 378, 379, 380, 381, 382, 383, 384, 385, 386, 387, 388, 389, 390, 391, 392, 393, 394, 395, 396, 397, 398, 399, 400, 401, 402, 403, 404, 405, 406, 407, 408, 409, 410, 411, 412, 413, 414, 415, 416, 417, 418, 419, 420, 421, 422, 423, 424, 425, 426, 427, 428, 429, 430, 431, 432, 433, 434, 435, 436, 437, 438, 439, 440, 441, 442, 443, 444, 445, 446, 447, 448, 449, 450, 451, 452, 453, 454, 455, 456, 457, 458, 459, 460, 461, 462, 463, 464, 465, 466, 467, 468, 469, 470, 471, 472, 473, 474, 475, 476, 477, 478, 479, 480, 481, 482, 483, 484, 485, 486, 487, 488, 489, 490, 491, 492, 493, 494, 495, 496, 497, 498, 499, 500, 501, 502, 503, 504, 505, 506, 507, 508, 509, 510, 511, 512, 513, 514, 515, 516, 517, 518, 519, 520, 521, 522, 523, 524, 525, 526, 527, 528, 529, 530, 531, 532, 533, 534, 535, 536, 537, 538, 539, 540, 541, 542, 543, 544, 545, 546, 547, 548, 549, 550, 551, 552, 553, 554, 555, 556, 557, 558, 559, 560, 561, 562, 563, 564, 565, 566, 567, 568, 569, 570, 571, 572, 573, 574, 575, 576, 577, 578, 579, 580, 581, 582, 583, 584, 585, 586, 587, 588, 589, 590, 591, 592, 593, 594, 595, 596, 597, 598, 599, 600, 601, 602, 603, 604, 605, 606, 607, 608, 609, 610, 611, 612, 613, 614, 615, 616, 617, 618, 619, 620, 621, 622, 623, 624, 625, 626, 627, 628, 629, 630, 631, 632, 633, 634, 635, 636, 637, 638, 639, 640, 641, 642, 643, 644, 645, 646, 647, 648, 649, 650, 651, 652, 653, 654, 655, 656, 657, 658, 659, 660, 661, 662, 663, 664, 665, 666, 667, 668, 669, 670, 671, 672, 673, 674, 675, 676, 677, 678, 679, 680, 681, 682, 683, 684, 685, 686, 687, 688, 689, 690, 691, 692, 693, 694, 695, 696, 697, 698, 699, 700, 701, 702, 703, 704, 705, 706, 707, 708, 709, 710, 711, 712, 713, 714, 715, 716, 717, 718, 719, 720, 721, 722, 723, 724, 725, 726, 727, 728, 729, 730, 731, 732, 733, 734, 735, 736, 737, 738, 739, 740, 741, 742, 743, 744, 745, 746, 747, 748, 749, 750, 751, 752, 753, 754, 755, 756, 757, 758, 759, 760, 761, 762, 763, 764, 765, 766, 767, 768, 769, 770, 771, 772, 773, 774, 775, 776, 777, 778, 779, 780, 781, 782, 783, 784, 785, 786, 787, 788, 789, 790, 791, 792, 793, 794, 795, 796, 797, 798, 799, 800, 801, 802, 803, 804, 805, 806, 807, 808, 809, 810, 811, 812, 813, 814, 815, 816, 817, 818, 819, 820, 821, 822, 823, 824, 825, 826, 827, 828, 829, 830, 831, 832, 833, 834, 835, 836, 837, 838, 839, 840, 841, 842, 843, 844, 845, 846, 847, 848, 849, 850, 851, 852, 853, 854, 855, 856, 857, 858, 859, 860, 861, 862, 863, 864, 865, 866, 867, 868, 869, 870, 871, 872, 873, 874, 875, 876, 877, 878, 879, 880, 881, 882, 883, 884, 885, 886, 887, 888, 889, 890, 891, 892, 893, 894, 895, 896, 897, 898, 899, 900, 901, 902, 903, 904, 905, 906, 907, 908, 909, 910, 911, 912, 913, 914, 915, 916, 917, 918, 919, 920, 921, 922, 923, 924, 925, 926, 927, 928, 929, 930, 931, 932, 933, 934, 935, 936, 937, 938, 939, 940, 941, 942, 943, 944, 945, 946, 947, 948, 949, 950, 951, 952, 953, 954, 955, 956, 957, 958, 959, 960, 961, 962, 963, 964, 965, 966, 967, 968, 969, 970, 971, 972, 973, 974, 975, 976, 977, 978, 979, 980, 981, 982, 983, 984, 985, 986, 987, 988, 989, 990, 991, 992, 993, 994, 995, 996, 997, 998, 999, 1000

MAIN CONTRACTOR :
Gammon

STRUCTURAL ENGINEER :
ARUP

FACADE CONSULTANT:
MEINHARDT

NOTE :
 1. ALL DIMENSIONS ARE IN mm.
 2. ALL ELEVATIONS ARE VIEWED FROM OUTSIDE.
 3. ALL DIMENSIONS TO BE VERIFIED ON SITE BEFORE FABRICATION.

LEGEND :
 (x1) — DETAIL MARK NO.
 (x001) — REFER SHEET NO.
 1. F.F.L. -- FINISHED FLOOR LEVEL
 2. S.F.L. -- STRUCTURAL FLOOR LEVEL
 3. (R) -- REVERSED DETAIL
 -- FIXING LOCATION
 -- FIXING LUG LOCATION

GLASS LEGEND
 GL01 -- 8mm+12mm AIR GAP+10mm THK. I.G.U.
 GL01a -- 8mm+9mm AIR GAP+12mm THK. I.G.U.
 GL03 -- 6mm+12mm AIR GAP+6mm THK. I.G.U.
 GL04 -- 10mm THK. TEMPERED GLASS (PROTECTIVE BARRIER)
 GL05 -- 6mm+12mm AIR GAP+8mm THK. I.G.U.

NO.	DATE	REVISED	BY
-----	------	---------	----

JOB NO. : J-852
 PROJECT : PROPOSED RESIDENTIAL DEVELOPMENT AT 139 - 147 ARGYLE STREET, NKIL 6005, 6035 R.P., 6036 R.P., 6037 R.P. & 6038 R.P.

TITLE : DETAIL FOR Plenum Box

DATE : 05-Dec-19 SCALE : 1:2

DRAWN BY : MN CHECKED BY : DW

美特鋁質有限公司
MIDI ALUMINIUM FABRICATOR LTD.
 Units 6-8, Sunray Industrial Centre, 1/F
 610 Cha Kwo Ling Road, Kowloon
 Tel:23489211-4 Fax:(852)2727666

DWG NO. : J852-SD-PB-5003a REV. : -

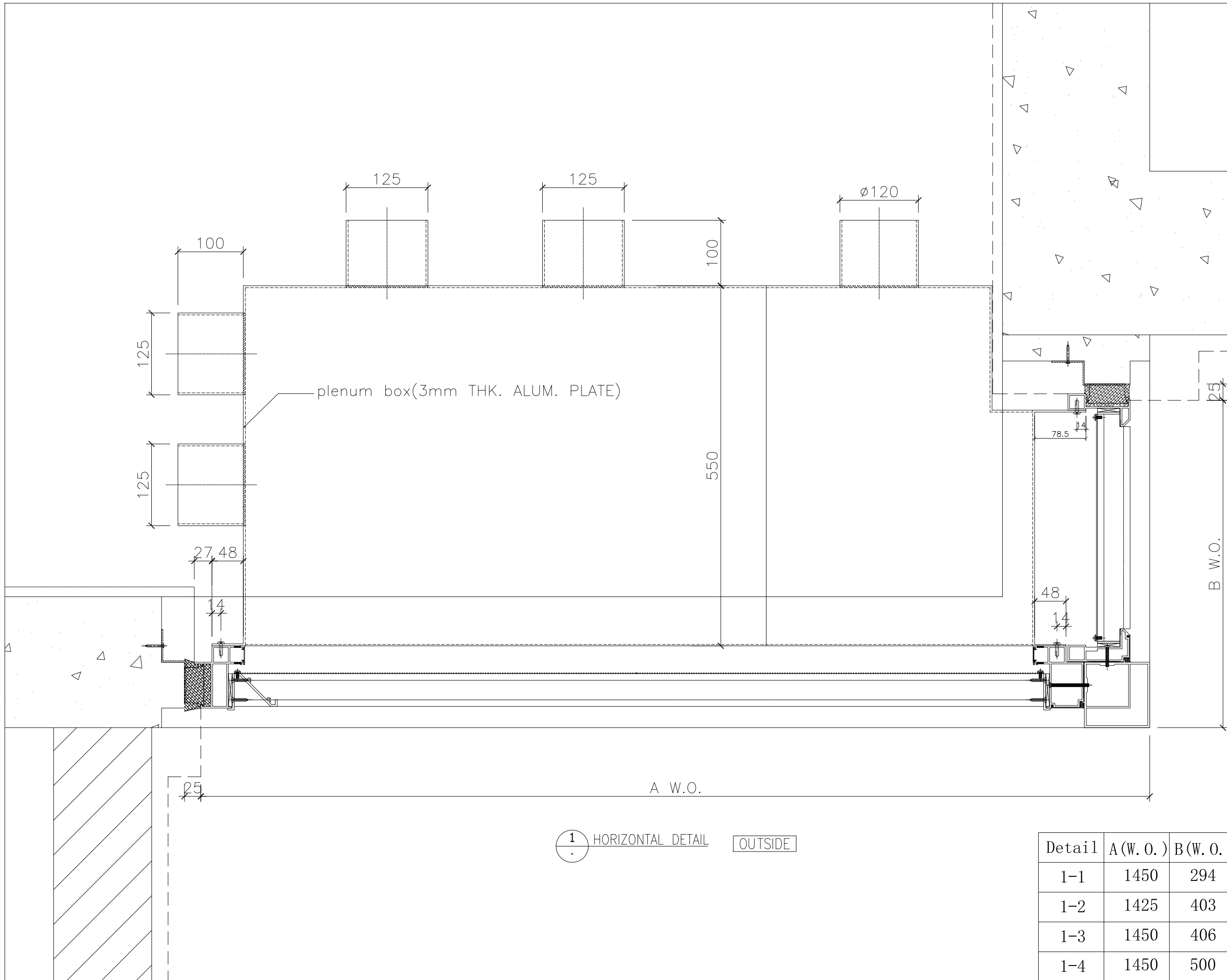

B.D. REF :

CLIENT :

ARCHITECT :
AGC DESIGN LTD
 100, 101, 102, 103, 104, 105, 106, 107, 108, 109, 110, 111, 112, 113, 114, 115, 116, 117, 118, 119, 120, 121, 122, 123, 124, 125, 126, 127, 128, 129, 130, 131, 132, 133, 134, 135, 136, 137, 138, 139, 140, 141, 142, 143, 144, 145, 146, 147, 148, 149, 150, 151, 152, 153, 154, 155, 156, 157, 158, 159, 160, 161, 162, 163, 164, 165, 166, 167, 168, 169, 170, 171, 172, 173, 174, 175, 176, 177, 178, 179, 180, 181, 182, 183, 184, 185, 186, 187, 188, 189, 190, 191, 192, 193, 194, 195, 196, 197, 198, 199, 200, 201, 202, 203, 204, 205, 206, 207, 208, 209, 210, 211, 212, 213, 214, 215, 216, 217, 218, 219, 220, 221, 222, 223, 224, 225, 226, 227, 228, 229, 230, 231, 232, 233, 234, 235, 236, 237, 238, 239, 240, 241, 242, 243, 244, 245, 246, 247, 248, 249, 250, 251, 252, 253, 254, 255, 256, 257, 258, 259, 260, 261, 262, 263, 264, 265, 266, 267, 268, 269, 270, 271, 272, 273, 274, 275, 276, 277, 278, 279, 280, 281, 282, 283, 284, 285, 286, 287, 288, 289, 290, 291, 292, 293, 294, 295, 296, 297, 298, 299, 300, 301, 302, 303, 304, 305, 306, 307, 308, 309, 310, 311, 312, 313, 314, 315, 316, 317, 318, 319, 320, 321, 322, 323, 324, 325, 326, 327, 328, 329, 330, 331, 332, 333, 334, 335, 336, 337, 338, 339, 340, 341, 342, 343, 344, 345, 346, 347, 348, 349, 350, 351, 352, 353, 354, 355, 356, 357, 358, 359, 360, 361, 362, 363, 364, 365, 366, 367, 368, 369, 370, 371, 372, 373, 374, 375, 376, 377, 378, 379, 380, 381, 382, 383, 384, 385, 386, 387, 388, 389, 390, 391, 392, 393, 394, 395, 396, 397, 398, 399, 400, 401, 402, 403, 404, 405, 406, 407, 408, 409, 410, 411, 412, 413, 414, 415, 416, 417, 418, 419, 420, 421, 422, 423, 424, 425, 426, 427, 428, 429, 430, 431, 432, 433, 434, 435, 436, 437, 438, 439, 440, 441, 442, 443, 444, 445, 446, 447, 448, 449, 450, 451, 452, 453, 454, 455, 456, 457, 458, 459, 460, 461, 462, 463, 464, 465, 466, 467, 468, 469, 470, 471, 472, 473, 474, 475, 476, 477, 478, 479, 480, 481, 482, 483, 484, 485, 486, 487, 488, 489, 490, 491, 492, 493, 494, 495, 496, 497, 498, 499, 500, 501, 502, 503, 504, 505, 506, 507, 508, 509, 510, 511, 512, 513, 514, 515, 516, 517, 518, 519, 520, 521, 522, 523, 524, 525, 526, 527, 528, 529, 530, 531, 532, 533, 534, 535, 536, 537, 538, 539, 540, 541, 542, 543, 544, 545, 546, 547, 548, 549, 550, 551, 552, 553, 554, 555, 556, 557, 558, 559, 560, 561, 562, 563, 564, 565, 566, 567, 568, 569, 570, 571, 572, 573, 574, 575, 576, 577, 578, 579, 580, 581, 582, 583, 584, 585, 586, 587, 588, 589, 590, 591, 592, 593, 594, 595, 596, 597, 598, 599, 600, 601, 602, 603, 604, 605, 606, 607, 608, 609, 610, 611, 612, 613, 614, 615, 616, 617, 618, 619, 620, 621, 622, 623, 624, 625, 626, 627, 628, 629, 630, 631, 632, 633, 634, 635, 636, 637, 638, 639, 640, 641, 642, 643, 644, 645, 646, 647, 648, 649, 650, 651, 652, 653, 654, 655, 656, 657, 658, 659, 660, 661, 662, 663, 664, 665, 666, 667, 668, 669, 670, 671, 672, 673, 674, 675, 676, 677, 678, 679, 680, 681, 682, 683, 684, 685, 686, 687, 688, 689, 690, 691, 692, 693, 694, 695, 696, 697, 698, 699, 700, 701, 702, 703, 704, 705, 706, 707, 708, 709, 710, 711, 712, 713, 714, 715, 716, 717, 718, 719, 720, 721, 722, 723, 724, 725, 726, 727, 728, 729, 730, 731, 732, 733, 734, 735, 736, 737, 738, 739, 740, 741, 742, 743, 744, 745, 746, 747, 748, 749, 750, 751, 752, 753, 754, 755, 756, 757, 758, 759, 760, 761, 762, 763, 764, 765, 766, 767, 768, 769, 770, 771, 772, 773, 774, 775, 776, 777, 778, 779, 780, 781, 782, 783, 784, 785, 786, 787, 788, 789, 790, 791, 792, 793, 794, 795, 796, 797, 798, 799, 800, 801, 802, 803, 804, 805, 806, 807, 808, 809, 810, 811, 812, 813, 814, 815, 816, 817, 818, 819, 820, 821, 822, 823, 824, 825, 826, 827, 828, 829, 830, 831, 832, 833, 834, 835, 836, 837, 838, 839, 840, 841, 842, 843, 844, 845, 846, 847, 848, 849, 850, 851, 852, 853, 854, 855, 856, 857, 858, 859, 860, 861, 862, 863, 864, 865, 866, 867, 868, 869, 870, 871, 872, 873, 874, 875, 876, 877, 878, 879, 880, 881, 882, 883, 884, 885, 886, 887, 888, 889, 890, 891, 892, 893, 894, 895, 896, 897, 898, 899, 900, 901, 902, 903, 904, 905, 906, 907, 908, 909, 910, 911, 912, 913, 914, 915, 916, 917, 918, 919, 920, 921, 922, 923, 924, 925, 926, 927, 928, 929, 930, 931, 932, 933, 934, 935, 936, 937, 938, 939, 940, 941, 942, 943, 944, 945, 946, 947, 948, 949, 950, 951, 952, 953, 954, 955, 956, 957, 958, 959, 960, 961, 962, 963, 964, 965, 966, 967, 968, 969, 970, 971, 972, 973, 974, 975, 976, 977, 978, 979, 980, 981, 982, 983, 984, 985, 986, 987, 988, 989, 990, 991, 992, 993, 994, 995, 996, 997, 998, 999, 1000

MAIN CONTRACTOR :
Gammon

STRUCTURAL ENGINEER :
ARUP

FACADE CONSULTANT:
MEINHARDT

NOTE :

1. ALL DIMENSIONS ARE IN mm.
2. ALL ELEVATIONS ARE VIEWED FROM OUTSIDE.
3. ALL DIMENSIONS TO BE VERIFIED ON SITE BEFORE FABRICATION.

LEGEND :

(x1) — DETAIL MARK NO.
 (x001) — REFER SHEET NO.

1. F.F.L. — FINISHED FLOOR LEVEL
2. S.F.L. — STRUCTURAL FLOOR LEVEL
3. (R) — REVERSED DETAIL
- FIXING LOCATION
- FIXING LUG LOCATION

GLASS LEGEND

GL01 — 8mm+12mm AIR GAP+10mm THK. I.G.U.
 GL01a — 8mm+9mm AIR GAP+12mm THK. I.G.U.
 GL03 — 6mm+12mm AIR GAP+6mm THK. I.G.U.
 GL04 — 10mm THK. TEMPERED GLASS (PROTECTIVE BARRIER)
 GL05 — 6mm+12mm AIR GAP+8mm THK. I.G.U.

NO.	DATE	REVISION	BY
A	09/12/2020	REVISION SUBJECT TO ARCH.COMMENT	lvn

JOB NO. : J-852

PROJECT :
 PROPOSED RESIDENTIAL DEVELOPMENT
 AT 139 - 147 ARGYLE STREET,
 NKIL 6005, 6035 R.P., 6036 R.P.,
 6037 R.P. & 6038 R.P.

TITLE :
 DETAIL FOR
 Plenum Box

DATE : 05-Dec-19 SCALE : 1:2

DRAWN BY : MN CHECKED BY : DW

美特鋁質有限公司
MIDI ALUMINIUM FABRICATOR LTD.
 Units 6-8, Sunray Industrial Centre, 1/F
 610 Cha Kwo Ling Road, Kowloon
 Tel:23489211-4 Fax:(852)2727666

DWG NO. : J852-SD-PB-5004 REV. : A

Detail	A (W. O.)	B (W. O.)
1-1	1450	294
1-2	1425	403
1-3	1450	406
1-4	1450	500

1 HORIZONTAL DETAIL OUTSIDE

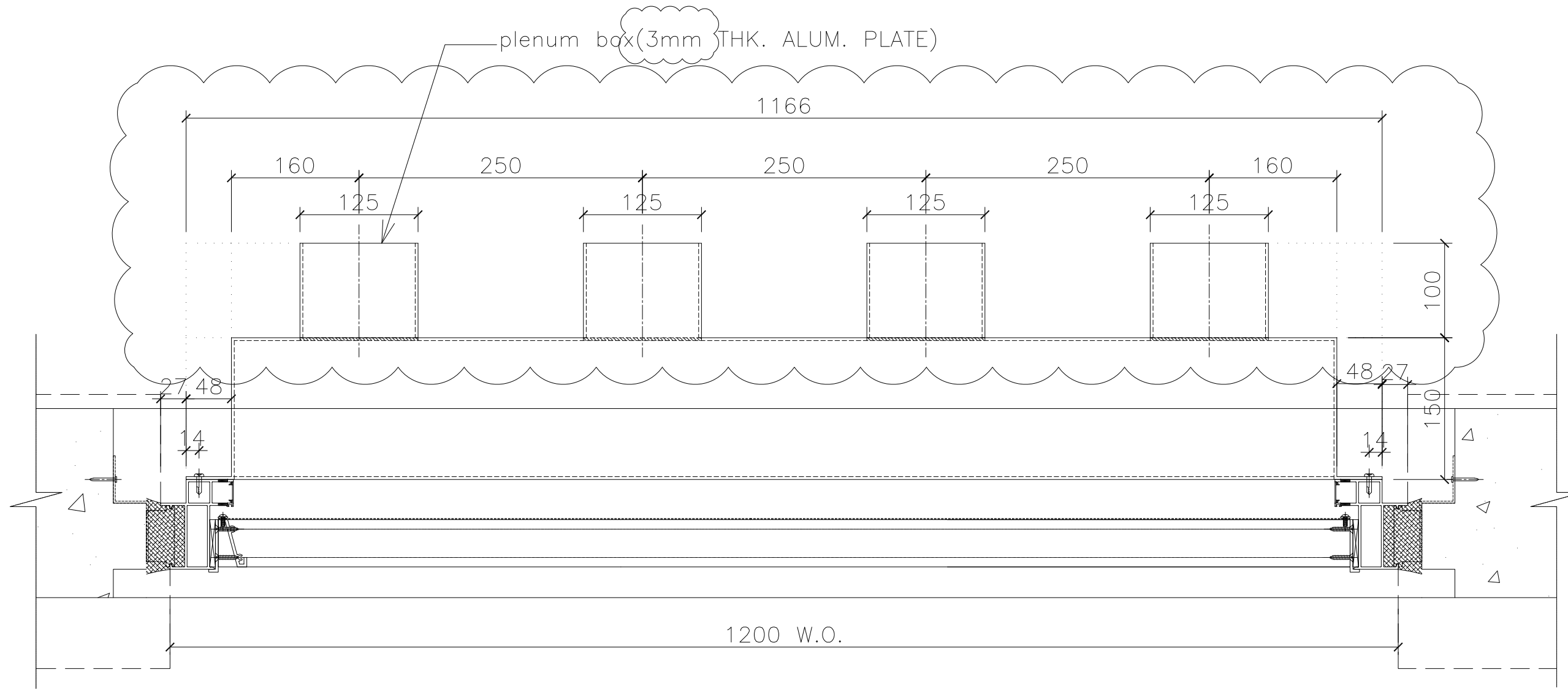

1 HORIZONTAL DETAIL OUTSIDE

B.D. REF :

CLIENT :

ARCHITECT :
AGC DESIGN LTD
 101, 102, 103, 104, 105, 106, 107, 108, 109, 110, 111, 112, 113, 114, 115, 116, 117, 118, 119, 120, 121, 122, 123, 124, 125, 126, 127, 128, 129, 130, 131, 132, 133, 134, 135, 136, 137, 138, 139, 140, 141, 142, 143, 144, 145, 146, 147, 148, 149, 150, 151, 152, 153, 154, 155, 156, 157, 158, 159, 160, 161, 162, 163, 164, 165, 166, 167, 168, 169, 170, 171, 172, 173, 174, 175, 176, 177, 178, 179, 180, 181, 182, 183, 184, 185, 186, 187, 188, 189, 190, 191, 192, 193, 194, 195, 196, 197, 198, 199, 200

MAIN CONTRACTOR :
Gammon

STRUCTURAL ENGINEER :
ARUP

FACADE CONSULTANT:
MEINHARDT

NOTE :
 1. ALL DIMENSIONS ARE IN mm.
 2. ALL ELEVATIONS ARE VIEWED FROM OUTSIDE.
 3. ALL DIMENSIONS TO BE VERIFIED ON SITE BEFORE FABRICATION.

LEGEND :
 (x1) — DETAIL MARK NO.
 (x001) — REFER SHEET NO.
 1. F.F.L. — FINISHED FLOOR LEVEL
 2. S.F.L. — STRUCTURAL FLOOR LEVEL
 3. (R) — REVERSED DETAIL
 — FIXING LOCATION
 — FIXING LUG LOCATION

GLASS LEGEND
 GL01 — 8mm+12mm AIR GAP+10mm THK. I.G.U.
 GL01a — 8mm+9mm AIR GAP+12mm THK. I.G.U.
 GL03 — 6mm+12mm AIR GAP+6mm THK. I.G.U.
 GL04 — 10mm THK. TEMPERED GLASS (PROTECTIVE BARRIER)
 GL05 — 6mm+12mm AIR GAP+8mm THK. I.G.U.

NO.	DATE	REVISION	BY
A	09/12/2020	REVISION SUBJECT TO ARCH.COMMENT	lvn

JOB NO. : J-852
 PROJECT :
 PROPOSED RESIDENTIAL DEVELOPMENT
 AT 139 - 147 ARGYLE STREET,
 NKIL 6005, 6035 R.P., 6036 R.P.,
 6037 R.P. & 6038 R.P.

TITLE :
 DETAIL FOR
 Plenum Box

DATE : 05-Dec-19 SCALE : 1:2
 DRAWN BY : MN CHECKED BY : DW

美特鋁質有限公司
MIDI ALUMINIUM FABRICATOR LTD.
 Units 6-8, Sunray Industrial Centre, 1/F
 610 Cha Kwo Ling Road, Kowloon
 Tel:23489211-4 Fax:(852)2727666

DWG NO. : J852-SD-PB-5005 REV. : A

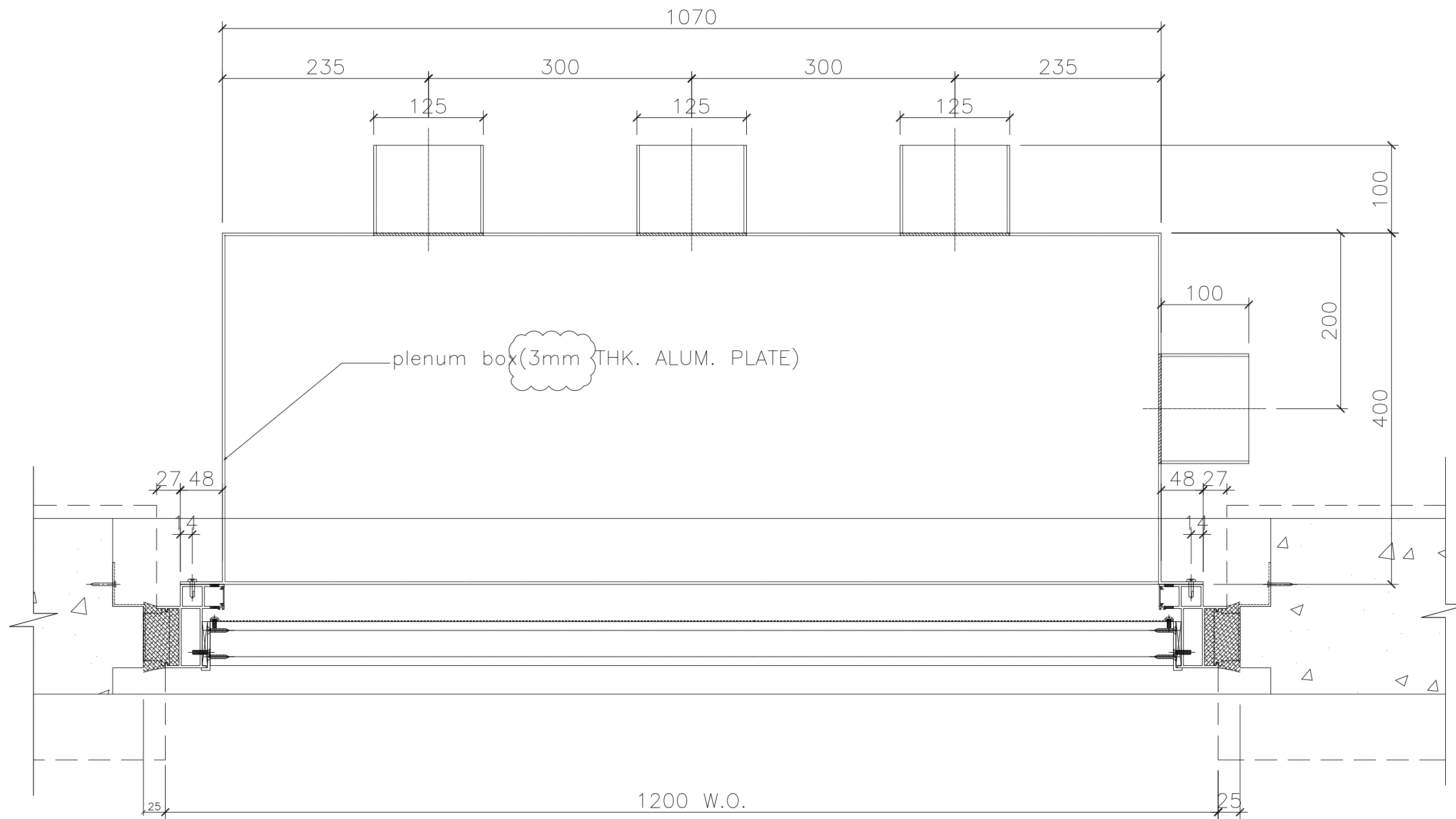

1 HORIZONTAL DETAIL OUTSIDE
SCALE 1:1

B.D. REF :

CLIENT :

ARCHITECT :
AGC DESIGN LTD
AGC DESIGN LTD
101, 102, 103, 104, 105, 106, 107, 108, 109, 110, 111, 112, 113, 114, 115, 116, 117, 118, 119, 120, 121, 122, 123, 124, 125, 126, 127, 128, 129, 130, 131, 132, 133, 134, 135, 136, 137, 138, 139, 140, 141, 142, 143, 144, 145, 146, 147, 148, 149, 150, 151, 152, 153, 154, 155, 156, 157, 158, 159, 160, 161, 162, 163, 164, 165, 166, 167, 168, 169, 170, 171, 172, 173, 174, 175, 176, 177, 178, 179, 180, 181, 182, 183, 184, 185, 186, 187, 188, 189, 190, 191, 192, 193, 194, 195, 196, 197, 198, 199, 200, 201, 202, 203, 204, 205, 206, 207, 208, 209, 210, 211, 212, 213, 214, 215, 216, 217, 218, 219, 220, 221, 222, 223, 224, 225, 226, 227, 228, 229, 230, 231, 232, 233, 234, 235, 236, 237, 238, 239, 240, 241, 242, 243, 244, 245, 246, 247, 248, 249, 250, 251, 252, 253, 254, 255, 256, 257, 258, 259, 260, 261, 262, 263, 264, 265, 266, 267, 268, 269, 270, 271, 272, 273, 274, 275, 276, 277, 278, 279, 280, 281, 282, 283, 284, 285, 286, 287, 288, 289, 290, 291, 292, 293, 294, 295, 296, 297, 298, 299, 300, 301, 302, 303, 304, 305, 306, 307, 308, 309, 310, 311, 312, 313, 314, 315, 316, 317, 318, 319, 320, 321, 322, 323, 324, 325, 326, 327, 328, 329, 330, 331, 332, 333, 334, 335, 336, 337, 338, 339, 340, 341, 342, 343, 344, 345, 346, 347, 348, 349, 350, 351, 352, 353, 354, 355, 356, 357, 358, 359, 360, 361, 362, 363, 364, 365, 366, 367, 368, 369, 370, 371, 372, 373, 374, 375, 376, 377, 378, 379, 380, 381, 382, 383, 384, 385, 386, 387, 388, 389, 390, 391, 392, 393, 394, 395, 396, 397, 398, 399, 400, 401, 402, 403, 404, 405, 406, 407, 408, 409, 410, 411, 412, 413, 414, 415, 416, 417, 418, 419, 420, 421, 422, 423, 424, 425, 426, 427, 428, 429, 430, 431, 432, 433, 434, 435, 436, 437, 438, 439, 440, 441, 442, 443, 444, 445, 446, 447, 448, 449, 450, 451, 452, 453, 454, 455, 456, 457, 458, 459, 460, 461, 462, 463, 464, 465, 466, 467, 468, 469, 470, 471, 472, 473, 474, 475, 476, 477, 478, 479, 480, 481, 482, 483, 484, 485, 486, 487, 488, 489, 490, 491, 492, 493, 494, 495, 496, 497, 498, 499, 500, 501, 502, 503, 504, 505, 506, 507, 508, 509, 510, 511, 512, 513, 514, 515, 516, 517, 518, 519, 520, 521, 522, 523, 524, 525, 526, 527, 528, 529, 530, 531, 532, 533, 534, 535, 536, 537, 538, 539, 540, 541, 542, 543, 544, 545, 546, 547, 548, 549, 550, 551, 552, 553, 554, 555, 556, 557, 558, 559, 560, 561, 562, 563, 564, 565, 566, 567, 568, 569, 570, 571, 572, 573, 574, 575, 576, 577, 578, 579, 580, 581, 582, 583, 584, 585, 586, 587, 588, 589, 590, 591, 592, 593, 594, 595, 596, 597, 598, 599, 600, 601, 602, 603, 604, 605, 606, 607, 608, 609, 610, 611, 612, 613, 614, 615, 616, 617, 618, 619, 620, 621, 622, 623, 624, 625, 626, 627, 628, 629, 630, 631, 632, 633, 634, 635, 636, 637, 638, 639, 640, 641, 642, 643, 644, 645, 646, 647, 648, 649, 650, 651, 652, 653, 654, 655, 656, 657, 658, 659, 660, 661, 662, 663, 664, 665, 666, 667, 668, 669, 670, 671, 672, 673, 674, 675, 676, 677, 678, 679, 680, 681, 682, 683, 684, 685, 686, 687, 688, 689, 690, 691, 692, 693, 694, 695, 696, 697, 698, 699, 700, 701, 702, 703, 704, 705, 706, 707, 708, 709, 710, 711, 712, 713, 714, 715, 716, 717, 718, 719, 720, 721, 722, 723, 724, 725, 726, 727, 728, 729, 730, 731, 732, 733, 734, 735, 736, 737, 738, 739, 740, 741, 742, 743, 744, 745, 746, 747, 748, 749, 750, 751, 752, 753, 754, 755, 756, 757, 758, 759, 760, 761, 762, 763, 764, 765, 766, 767, 768, 769, 770, 771, 772, 773, 774, 775, 776, 777, 778, 779, 780, 781, 782, 783, 784, 785, 786, 787, 788, 789, 790, 791, 792, 793, 794, 795, 796, 797, 798, 799, 800, 801, 802, 803, 804, 805, 806, 807, 808, 809, 810, 811, 812, 813, 814, 815, 816, 817, 818, 819, 820, 821, 822, 823, 824, 825, 826, 827, 828, 829, 830, 831, 832, 833, 834, 835, 836, 837, 838, 839, 840, 841, 842, 843, 844, 845, 846, 847, 848, 849, 850, 851, 852, 853, 854, 855, 856, 857, 858, 859, 860, 861, 862, 863, 864, 865, 866, 867, 868, 869, 870, 871, 872, 873, 874, 875, 876, 877, 878, 879, 880, 881, 882, 883, 884, 885, 886, 887, 888, 889, 890, 891, 892, 893, 894, 895, 896, 897, 898, 899, 900, 901, 902, 903, 904, 905, 906, 907, 908, 909, 910, 911, 912, 913, 914, 915, 916, 917, 918, 919, 920, 921, 922, 923, 924, 925, 926, 927, 928, 929, 930, 931, 932, 933, 934, 935, 936, 937, 938, 939, 940, 941, 942, 943, 944, 945, 946, 947, 948, 949, 950, 951, 952, 953, 954, 955, 956, 957, 958, 959, 960, 961, 962, 963, 964, 965, 966, 967, 968, 969, 970, 971, 972, 973, 974, 975, 976, 977, 978, 979, 980, 981, 982, 983, 984, 985, 986, 987, 988, 989, 990, 991, 992, 993, 994, 995, 996, 997, 998, 999, 1000

MAIN CONTRACTOR :
Gammon

STRUCTURAL ENGINEER :
ARUP

FACADE CONSULTANT:
MEINHARDT

- NOTE :
- ALL DIMENSIONS ARE IN mm.
 - ALL ELEVATIONS ARE VIEWED FROM OUTSIDE.
 - ALL DIMENSIONS TO BE VERIFIED ON SITE BEFORE FABRICATION.
- LEGEND :
- x1 -- DETAIL MARK NO.
 - x001 -- REFER SHEET NO.
 - 1. F.F.L. -- FINISHED FLOOR LEVEL
 - 2. S.F.L. -- STRUCTURAL FLOOR LEVEL
 - 3. (R) -- REVERSED DETAIL
 - FIXING LOCATION
 - FIXING LUG LOCATION
- GLASS LEGEND
- GL01 -- 8mm+12mm AIR GAP+10mm THK. I.G.U.
 - GL01a -- 8mm+9mm AIR GAP+12mm THK. I.G.U.
 - GL03 -- 6mm+12mm AIR GAP+6mm THK. I.G.U.
 - GL04 -- 10mm THK. TEMPERED GLASS (PROTECTIVE BARRIER)
 - GL05 -- 6mm+12mm AIR GAP+8mm THK. I.G.U.

NO.	DATE	REVISED	BY
JOB NO. : J-852			
PROJECT : PROPOSED RESIDENTIAL DEVELOPMENT AT 139 - 147 ARGYLE STREET, NKIL 6005, 6035 R.P., 6036 R.P., 6037 R.P. & 6038 R.P.			
TITLE : DETAIL FOR Plenum Box			
DATE : 05-Dec-19		SCALE : 1:2	
DRAWN BY : MN		CHECKED BY : DW	
<p>MIDI ALUMINIUM FABRICATOR LTD. Units 6-8, Sunray Industrial Centre, 1/F 610 Cha Kwo Ling Road, Kowloon Tel:23489211-4 Fax:(852)2727666</p>			
DWG NO. : J852-SD-PB-5006			REV. : -

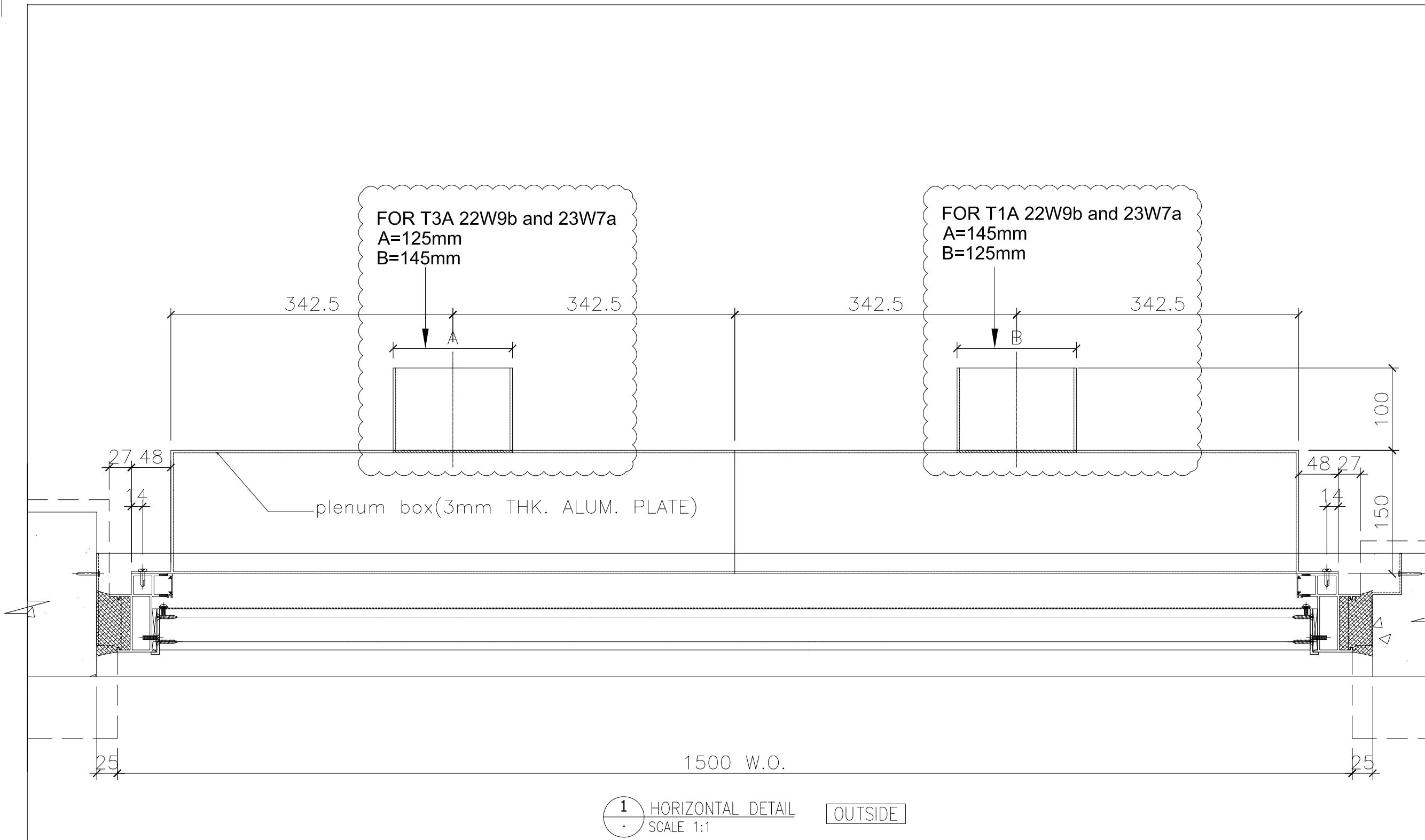

1 HORIZONTAL DETAIL
SCALE 1:1

OUTSIDE

B.D. REF :

CLIENT :

ARCHITECT :
AGC DESIGN LTD

MAIN CONTRACTOR :
Gammon

STRUCTURAL ENGINEER :
ARUP

FAÇADE CONSULTANT:
MEINHARDT

NOTE :
1. ALL DIMENSIONS ARE IN mm.
2. ALL ELEVATIONS ARE VIEWED FROM OUTSIDE.
3. ALL DIMENSIONS TO BE VERIFIED ON SITE BEFORE FABRICATION.

LEGEND :
x1 - DETAIL MARK NO.
X001 - REFER SHEET NO.
1. F.F.L. -- FINISHED FLOOR LEVEL
2. S.F.L. -- STRUCTURAL FLOOR LEVEL
3. (R) -- REVERSED DETAIL
-- FIXING LOCATION
-- FIXING LUG LOCATION

GLASS LEGEND
GL01 -- 8mm+12mm AIR GAP+10mm THK. I.G.U.
GL01a -- 8mm+9mm AIR GAP+12mm THK. I.G.U.
GL03 -- 6mm+12mm AIR GAP+6mm THK. I.G.U.
GL04 -- 10mm THK. TEMPERED GLASS (PROTECTIVE BARRIER)
GL05 -- 6mm+12mm AIR GAP+8mm THK. I.G.U.

NO.	DATE	REVISED	BY
B	06/01/2021	REVISION SUBJECT TO ARCH.COMMENT	Ivan
A	30/11/2020	REVISION SUBJECT TO ARCH.COMMENT	Ivan

JOB NO. : J-852
PROJECT :
PROPOSED RESIDENTIAL DEVELOPMENT
AT 139 - 147 ARGYLE STREET,
NKIL 6005, 6035 R.P., 6036 R.P.,
6037 R.P. & 6038 R.P.

TITLE :
DETAIL FOR
Plenum Box

DATE : 05-Dec-19 SCALE : 1:2
DRAWN BY : MN CHECKED BY : DW

美特鋁質有限公司
MIDI ALUMINIUM FABRICATOR LTD.
Units 6-8, Sunray Industrial Centre, 1/F
610 Cha Kwo Ling Road, Kowloon
Tel:23489211-4 Fax:(852)2727666

DWG NO. : J852-SD-PB-5007 REV. : B

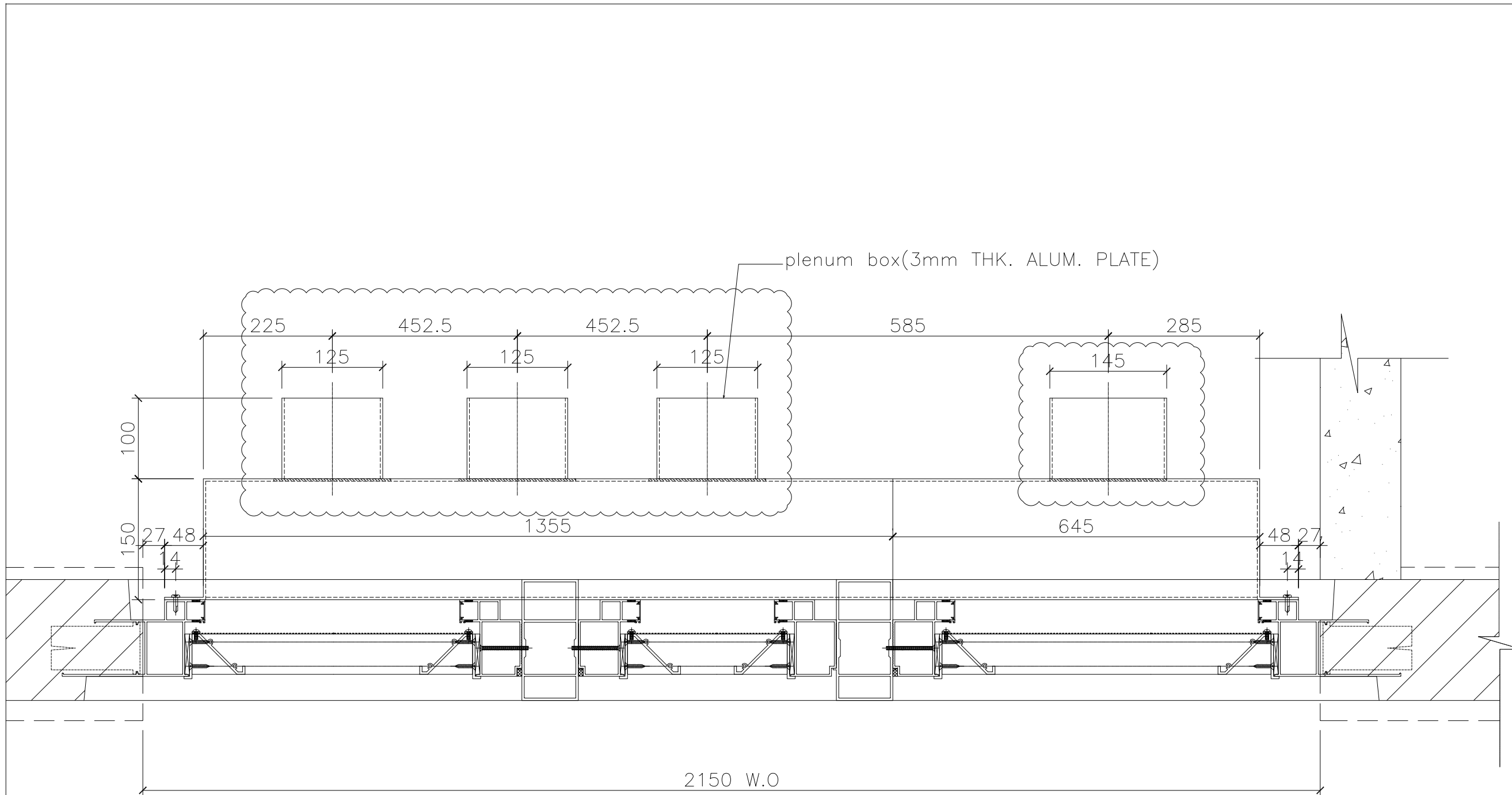

① HORIZONTAL DETAIL OUTSIDE

B.D. REF :

CLIENT :

ARCHITECT :
AGC DESIGN LTD
 181, 182, 183, 184, 185, 186, 187, 188, 189, 190, 191, 192, 193, 194, 195, 196, 197, 198, 199, 200, 201, 202, 203, 204, 205, 206, 207, 208, 209, 210, 211, 212, 213, 214, 215, 216, 217, 218, 219, 220, 221, 222, 223, 224, 225, 226, 227, 228, 229, 230, 231, 232, 233, 234, 235, 236, 237, 238, 239, 240, 241, 242, 243, 244, 245, 246, 247, 248, 249, 250, 251, 252, 253, 254, 255, 256, 257, 258, 259, 260, 261, 262, 263, 264, 265, 266, 267, 268, 269, 270, 271, 272, 273, 274, 275, 276, 277, 278, 279, 280, 281, 282, 283, 284, 285, 286, 287, 288, 289, 290, 291, 292, 293, 294, 295, 296, 297, 298, 299, 300, 301, 302, 303, 304, 305, 306, 307, 308, 309, 310, 311, 312, 313, 314, 315, 316, 317, 318, 319, 320, 321, 322, 323, 324, 325, 326, 327, 328, 329, 330, 331, 332, 333, 334, 335, 336, 337, 338, 339, 340, 341, 342, 343, 344, 345, 346, 347, 348, 349, 350, 351, 352, 353, 354, 355, 356, 357, 358, 359, 360, 361, 362, 363, 364, 365, 366, 367, 368, 369, 370, 371, 372, 373, 374, 375, 376, 377, 378, 379, 380, 381, 382, 383, 384, 385, 386, 387, 388, 389, 390, 391, 392, 393, 394, 395, 396, 397, 398, 399, 400, 401, 402, 403, 404, 405, 406, 407, 408, 409, 410, 411, 412, 413, 414, 415, 416, 417, 418, 419, 420, 421, 422, 423, 424, 425, 426, 427, 428, 429, 430, 431, 432, 433, 434, 435, 436, 437, 438, 439, 440, 441, 442, 443, 444, 445, 446, 447, 448, 449, 450, 451, 452, 453, 454, 455, 456, 457, 458, 459, 460, 461, 462, 463, 464, 465, 466, 467, 468, 469, 470, 471, 472, 473, 474, 475, 476, 477, 478, 479, 480, 481, 482, 483, 484, 485, 486, 487, 488, 489, 490, 491, 492, 493, 494, 495, 496, 497, 498, 499, 500, 501, 502, 503, 504, 505, 506, 507, 508, 509, 510, 511, 512, 513, 514, 515, 516, 517, 518, 519, 520, 521, 522, 523, 524, 525, 526, 527, 528, 529, 530, 531, 532, 533, 534, 535, 536, 537, 538, 539, 540, 541, 542, 543, 544, 545, 546, 547, 548, 549, 550, 551, 552, 553, 554, 555, 556, 557, 558, 559, 560, 561, 562, 563, 564, 565, 566, 567, 568, 569, 570, 571, 572, 573, 574, 575, 576, 577, 578, 579, 580, 581, 582, 583, 584, 585, 586, 587, 588, 589, 590, 591, 592, 593, 594, 595, 596, 597, 598, 599, 600, 601, 602, 603, 604, 605, 606, 607, 608, 609, 610, 611, 612, 613, 614, 615, 616, 617, 618, 619, 620, 621, 622, 623, 624, 625, 626, 627, 628, 629, 630, 631, 632, 633, 634, 635, 636, 637, 638, 639, 640, 641, 642, 643, 644, 645, 646, 647, 648, 649, 650, 651, 652, 653, 654, 655, 656, 657, 658, 659, 660, 661, 662, 663, 664, 665, 666, 667, 668, 669, 670, 671, 672, 673, 674, 675, 676, 677, 678, 679, 680, 681, 682, 683, 684, 685, 686, 687, 688, 689, 690, 691, 692, 693, 694, 695, 696, 697, 698, 699, 700, 701, 702, 703, 704, 705, 706, 707, 708, 709, 710, 711, 712, 713, 714, 715, 716, 717, 718, 719, 720, 721, 722, 723, 724, 725, 726, 727, 728, 729, 730, 731, 732, 733, 734, 735, 736, 737, 738, 739, 740, 741, 742, 743, 744, 745, 746, 747, 748, 749, 750, 751, 752, 753, 754, 755, 756, 757, 758, 759, 760, 761, 762, 763, 764, 765, 766, 767, 768, 769, 770, 771, 772, 773, 774, 775, 776, 777, 778, 779, 780, 781, 782, 783, 784, 785, 786, 787, 788, 789, 790, 791, 792, 793, 794, 795, 796, 797, 798, 799, 800, 801, 802, 803, 804, 805, 806, 807, 808, 809, 810, 811, 812, 813, 814, 815, 816, 817, 818, 819, 820, 821, 822, 823, 824, 825, 826, 827, 828, 829, 830, 831, 832, 833, 834, 835, 836, 837, 838, 839, 840, 841, 842, 843, 844, 845, 846, 847, 848, 849, 850, 851, 852, 853, 854, 855, 856, 857, 858, 859, 860, 861, 862, 863, 864, 865, 866, 867, 868, 869, 870, 871, 872, 873, 874, 875, 876, 877, 878, 879, 880, 881, 882, 883, 884, 885, 886, 887, 888, 889, 890, 891, 892, 893, 894, 895, 896, 897, 898, 899, 900, 901, 902, 903, 904, 905, 906, 907, 908, 909, 910, 911, 912, 913, 914, 915, 916, 917, 918, 919, 920, 921, 922, 923, 924, 925, 926, 927, 928, 929, 930, 931, 932, 933, 934, 935, 936, 937, 938, 939, 940, 941, 942, 943, 944, 945, 946, 947, 948, 949, 950, 951, 952, 953, 954, 955, 956, 957, 958, 959, 960, 961, 962, 963, 964, 965, 966, 967, 968, 969, 970, 971, 972, 973, 974, 975, 976, 977, 978, 979, 980, 981, 982, 983, 984, 985, 986, 987, 988, 989, 990, 991, 992, 993, 994, 995, 996, 997, 998, 999, 1000

MAIN CONTRACTOR :
Gammon

STRUCTURAL ENGINEER :
ARUP

FACADE CONSULTANT:
MEINHARDT

NOTE :
 1. ALL DIMENSIONS ARE IN mm.
 2. ALL ELEVATIONS ARE VIEWED FROM OUTSIDE.
 3. ALL DIMENSIONS TO BE VERIFIED ON SITE BEFORE FABRICATION.

LEGEND :
 (X1) -- DETAIL MARK NO.
 (X001) -- REFER SHEET NO.
 1. F.F.L. -- FINISHED FLOOR LEVEL
 2. S.F.L. -- STRUCTURAL FLOOR LEVEL
 3. (R) -- REVERSED DETAIL

B	06/01/2021	REVISION SUBJECT TO ARCH.COMMENT	Ivan
A	30/11/2020	REVISION SUBJECT TO ARCH.COMMENT	Ivan
NO.	DATE	REVISED	BY

JOB NO. : J-852
 PROJECT :
 PROPOSED RESIDENTIAL DEVELOPMENT
 AT 139 - 147 ARGYLE STREET,
 NKIL 6005, 6035 R.P., 6036 R.P.,
 6037 R.P. & 6038 R.P.

TITLE :
 DETAIL FOR
 Plenum Box

DATE : 05-Dec-19 SCALE : 1:2

DRAWN BY : MN CHECKED BY : DW

美特鋁質有限公司
MIDI ALUMINIUM FABRICATOR LTD.
 Units 6-8, Sunray Industrial Centre, 1/F
 610 Cha Kwo Ling Road, Kowloon
 Tel:23489211-4 Fax:(852)2727666

DWG NO. : J852-SD-PB-5008 REV. : B

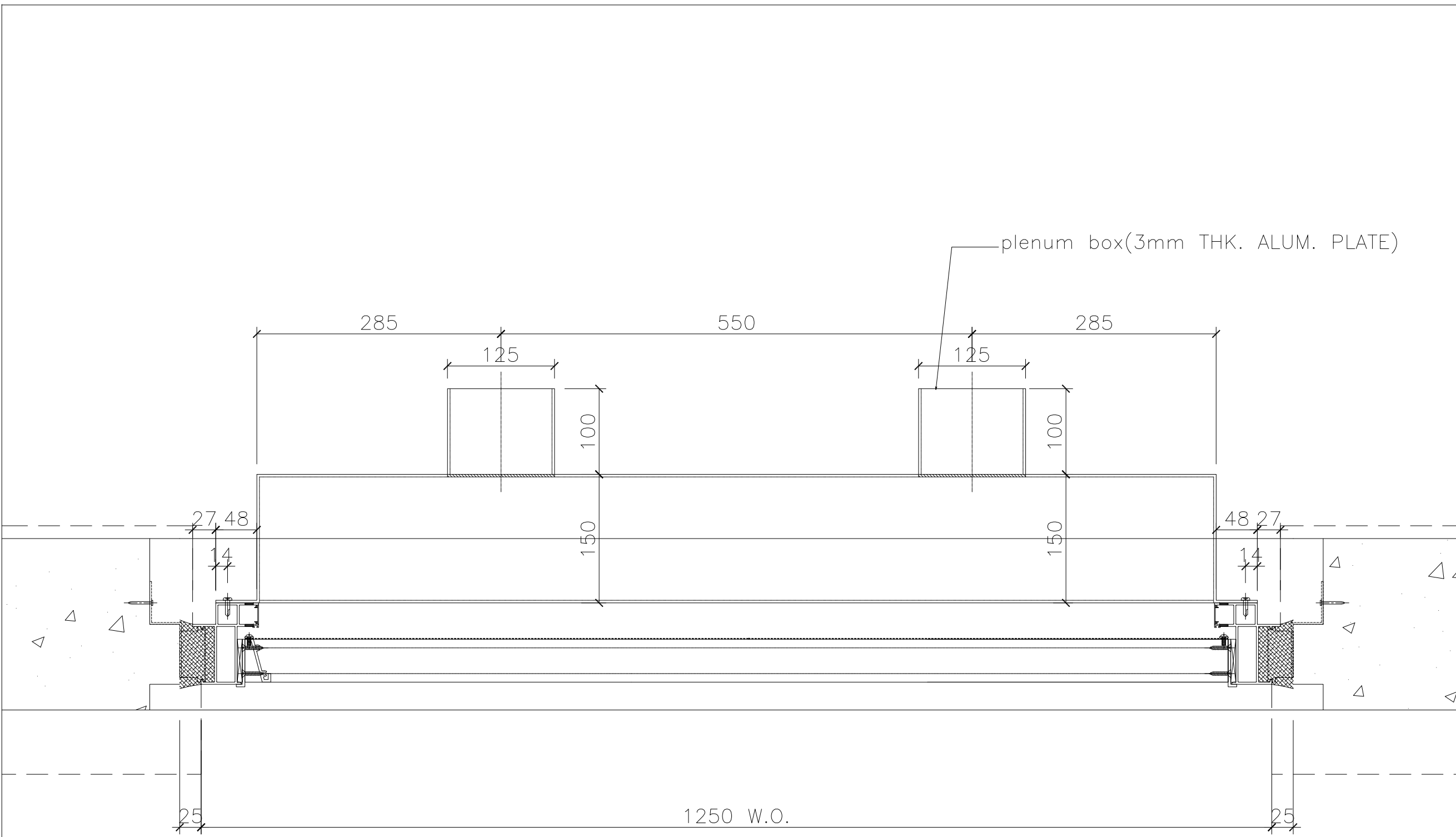

plenum box(3mm THK. ALUM. PLATE)

285

550

285

125

125

100

100

150

150

27 48

48 27

14

14

25

1250 W.O.

25

1 HORIZONTAL DETAIL
SCALE 1:1

OUTSIDE

B.D. REF :

CLIENT :

ARCHITECT :
AGC DESIGN LTD

MAIN CONTRACTOR :
Gammon

STRUCTURAL ENGINEER :
ARUP

FACADE CONSULTANT:
MEINHARDT

NOTE :
1. ALL DIMENSIONS ARE IN mm.
2. ALL ELEVATIONS ARE VIEWED FROM OUTSIDE.
3. ALL DIMENSIONS TO BE VERIFIED ON SITE BEFORE FABRICATION.

LEGEND :
x1 - DETAIL MARK NO.
x001 - REFER SHEET NO.
1. F.F.L. -- FINISHED FLOOR LEVEL
2. S.F.L. -- STRUCTURAL FLOOR LEVEL
3. (R) -- REVERSED DETAIL
-- FIXING LOCATION
-- FIXING LUG LOCATION

GLASS LEGEND
GL01 -- 8mm+12mm AIR GAP+10mm THK. I.G.U.
GL01a -- 8mm+9mm AIR GAP+12mm THK. I.G.U.
GL03 -- 6mm+12mm AIR GAP+6mm THK. I.G.U.
GL04 -- 10mm THK. TEMPERED GLASS (PROTECTIVE BARRIER)
GL05 -- 6mm+12mm AIR GAP+8mm THK. I.G.U.

NO.	DATE	REVISED	BY
-----	------	---------	----

JOB NO. : J-852
PROJECT : PROPOSED RESIDENTIAL DEVELOPMENT AT 139 - 147 ARGYLE STREET, NKIL 6005, 6035 R.P., 6036 R.P., 6037 R.P. & 6038 R.P.

TITLE :
DETAIL FOR Plenum Box

DATE : 05-Dec-19 SCALE : 1:2

DRAWN BY : MN CHECKED BY : DW

美特鋁質有限公司
MIDI ALUMINIUM FABRICATOR LTD.
Units 6-8, Sunray Industrial Centre, 1/F
610 Cha Kwo Ling Road, Kowloon
Tel:23489211-4 Fax:(852)2727666

DWG NO. : J852-SD-PB-5009 REV. : -

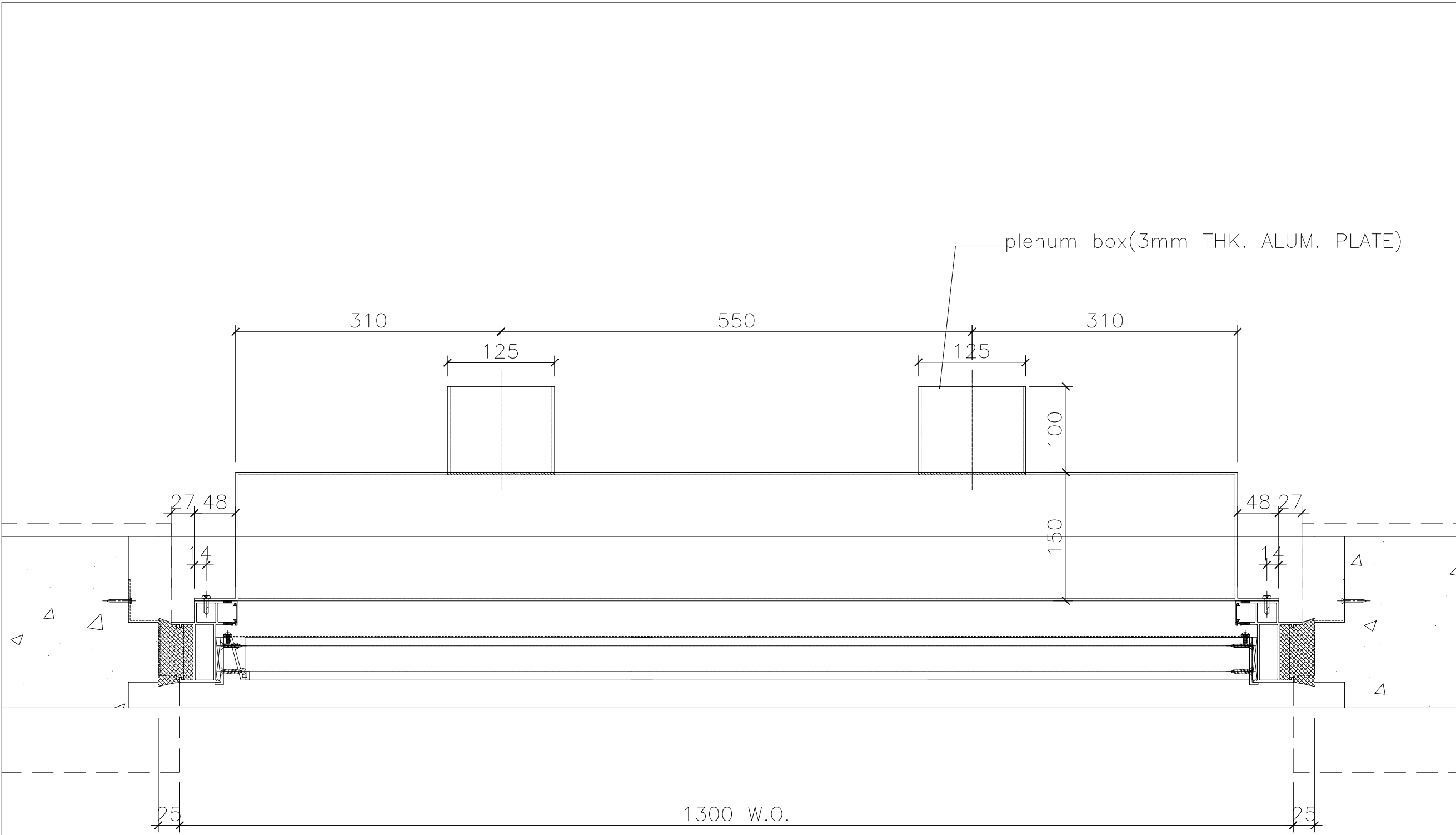

1 HORIZONTAL DETAIL
SCALE 1:1

OUTSIDE

B.D. REF :

CLIENT :

ARCHITECT :
AGC DESIGN LTD
AGC DESIGN LTD. 222, King's Road, North Point, Hong Kong
 Tel: (852) 2511 1111 Fax: (852) 2511 1112 Email: agc@agc.com.hk

MAIN CONTRACTOR :
Gammon

STRUCTURAL ENGINEER :
ARUP

FACADE CONSULTANT:
MEINHARDT

NOTE :

1. ALL DIMENSIONS ARE IN mm.
2. ALL ELEVATIONS ARE VIEWED FROM OUTSIDE.
3. ALL DIMENSIONS TO BE VERIFIED ON SITE BEFORE FABRICATION.

LEGEND :

(x1) — DETAIL MARK NO.
 (x001) — REFER SHEET NO.

1. F.F.L. — FINISHED FLOOR LEVEL
2. S.F.L. — STRUCTURAL FLOOR LEVEL
3. (R) — REVERSED DETAIL
 — FIXING LOCATION
 — FIXING LUG LOCATION

GLASS LEGEND

GL01 — 8mm+12mm AIR GAP+10mm THK. I.G.U.
 GL01a — 8mm+9mm AIR GAP+12mm THK. I.G.U.
 GL03 — 6mm+12mm AIR GAP+6mm THK. I.G.U.
 GL04 — 10mm THK. TEMPERED GLASS (PROTECTIVE BARRIER)
 GL05 — 6mm+12mm AIR GAP+8mm THK. I.G.U.

NO.	DATE	REVISED	BY
JOB NO. : J-852			
PROJECT : PROPOSED RESIDENTIAL DEVELOPMENT AT 139 - 147 ARGYLE STREET, NKIL 6005, 6035 R.P., 6036 R.P., 6037 R.P. & 6038 R.P.			
TITLE : DETAIL FOR Plenum Box			
DATE : 05-Dec-19		SCALE : 1:2	
DRAWN BY : MN		CHECKED BY : DW	
美特鋁質有限公司 MIDI ALUMINIUM FABRICATOR LTD. Units 6-8, Sunray Industrial Centre, 1/F 610 Cha Kwo Ling Road, Kowloon Tel:23489211-4 Fax:(852)2727666			
DWG NO. : J852-SD-PB-5010			REV. : -

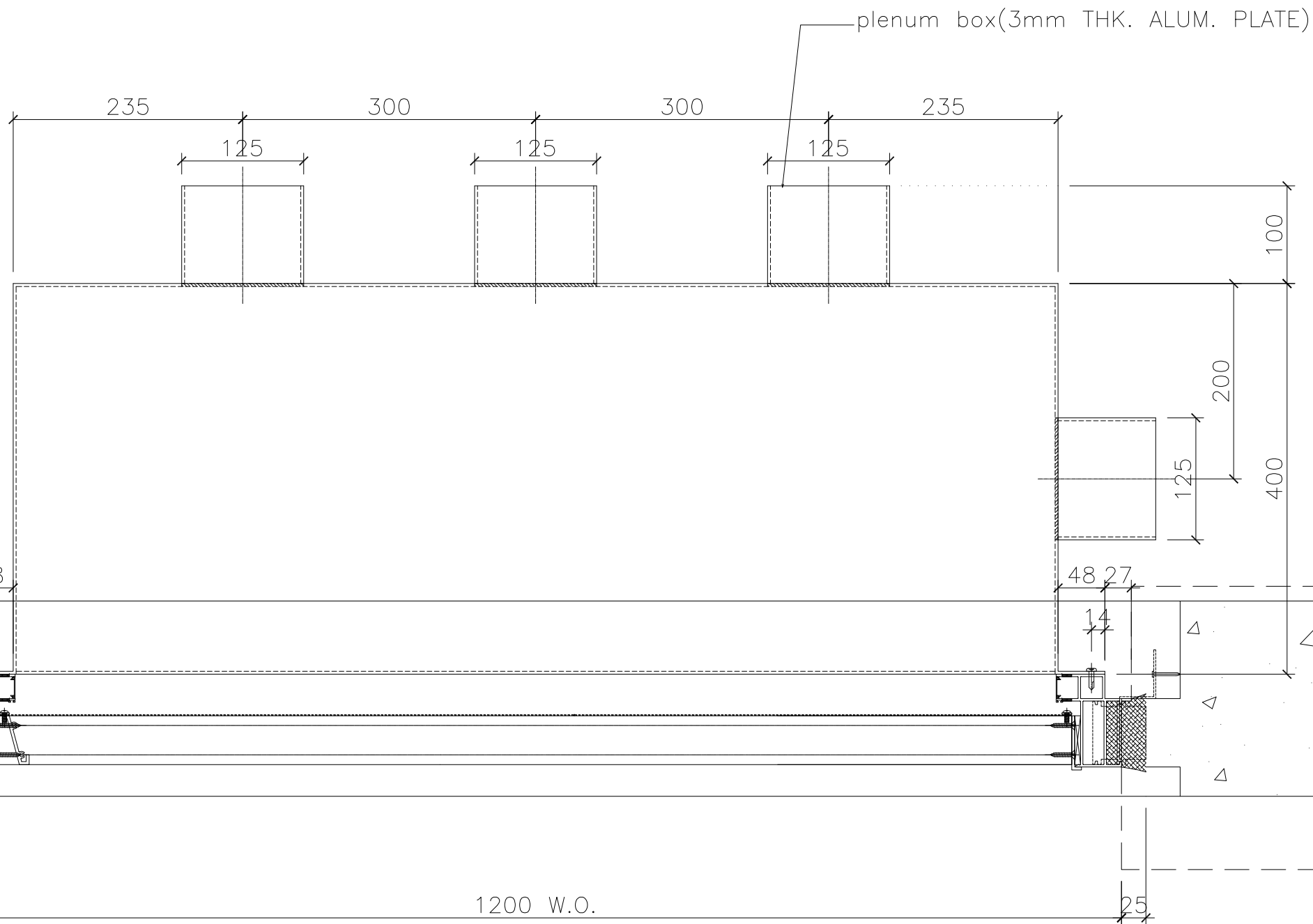

1 HORIZONTAL DETAIL
SCALE 1:1

OUTSIDE

B.D. REF :

CLIENT :

ARCHITECT :
AGC DESIGN LTD
AGC DESIGN LTD
101, 102, 103, 104, 105, 106, 107, 108, 109, 110, 111, 112, 113, 114, 115, 116, 117, 118, 119, 120, 121, 122, 123, 124, 125, 126, 127, 128, 129, 130, 131, 132, 133, 134, 135, 136, 137, 138, 139, 140, 141, 142, 143, 144, 145, 146, 147, 148, 149, 150, 151, 152, 153, 154, 155, 156, 157, 158, 159, 160, 161, 162, 163, 164, 165, 166, 167, 168, 169, 170, 171, 172, 173, 174, 175, 176, 177, 178, 179, 180, 181, 182, 183, 184, 185, 186, 187, 188, 189, 190, 191, 192, 193, 194, 195, 196, 197, 198, 199, 200, 201, 202, 203, 204, 205, 206, 207, 208, 209, 210, 211, 212, 213, 214, 215, 216, 217, 218, 219, 220, 221, 222, 223, 224, 225, 226, 227, 228, 229, 230, 231, 232, 233, 234, 235, 236, 237, 238, 239, 240, 241, 242, 243, 244, 245, 246, 247, 248, 249, 250, 251, 252, 253, 254, 255, 256, 257, 258, 259, 260, 261, 262, 263, 264, 265, 266, 267, 268, 269, 270, 271, 272, 273, 274, 275, 276, 277, 278, 279, 280, 281, 282, 283, 284, 285, 286, 287, 288, 289, 290, 291, 292, 293, 294, 295, 296, 297, 298, 299, 300, 301, 302, 303, 304, 305, 306, 307, 308, 309, 310, 311, 312, 313, 314, 315, 316, 317, 318, 319, 320, 321, 322, 323, 324, 325, 326, 327, 328, 329, 330, 331, 332, 333, 334, 335, 336, 337, 338, 339, 340, 341, 342, 343, 344, 345, 346, 347, 348, 349, 350, 351, 352, 353, 354, 355, 356, 357, 358, 359, 360, 361, 362, 363, 364, 365, 366, 367, 368, 369, 370, 371, 372, 373, 374, 375, 376, 377, 378, 379, 380, 381, 382, 383, 384, 385, 386, 387, 388, 389, 390, 391, 392, 393, 394, 395, 396, 397, 398, 399, 400, 401, 402, 403, 404, 405, 406, 407, 408, 409, 410, 411, 412, 413, 414, 415, 416, 417, 418, 419, 420, 421, 422, 423, 424, 425, 426, 427, 428, 429, 430, 431, 432, 433, 434, 435, 436, 437, 438, 439, 440, 441, 442, 443, 444, 445, 446, 447, 448, 449, 450, 451, 452, 453, 454, 455, 456, 457, 458, 459, 460, 461, 462, 463, 464, 465, 466, 467, 468, 469, 470, 471, 472, 473, 474, 475, 476, 477, 478, 479, 480, 481, 482, 483, 484, 485, 486, 487, 488, 489, 490, 491, 492, 493, 494, 495, 496, 497, 498, 499, 500, 501, 502, 503, 504, 505, 506, 507, 508, 509, 510, 511, 512, 513, 514, 515, 516, 517, 518, 519, 520, 521, 522, 523, 524, 525, 526, 527, 528, 529, 530, 531, 532, 533, 534, 535, 536, 537, 538, 539, 540, 541, 542, 543, 544, 545, 546, 547, 548, 549, 550, 551, 552, 553, 554, 555, 556, 557, 558, 559, 560, 561, 562, 563, 564, 565, 566, 567, 568, 569, 570, 571, 572, 573, 574, 575, 576, 577, 578, 579, 580, 581, 582, 583, 584, 585, 586, 587, 588, 589, 590, 591, 592, 593, 594, 595, 596, 597, 598, 599, 600, 601, 602, 603, 604, 605, 606, 607, 608, 609, 610, 611, 612, 613, 614, 615, 616, 617, 618, 619, 620, 621, 622, 623, 624, 625, 626, 627, 628, 629, 630, 631, 632, 633, 634, 635, 636, 637, 638, 639, 640, 641, 642, 643, 644, 645, 646, 647, 648, 649, 650, 651, 652, 653, 654, 655, 656, 657, 658, 659, 660, 661, 662, 663, 664, 665, 666, 667, 668, 669, 670, 671, 672, 673, 674, 675, 676, 677, 678, 679, 680, 681, 682, 683, 684, 685, 686, 687, 688, 689, 690, 691, 692, 693, 694, 695, 696, 697, 698, 699, 700, 701, 702, 703, 704, 705, 706, 707, 708, 709, 710, 711, 712, 713, 714, 715, 716, 717, 718, 719, 720, 721, 722, 723, 724, 725, 726, 727, 728, 729, 730, 731, 732, 733, 734, 735, 736, 737, 738, 739, 740, 741, 742, 743, 744, 745, 746, 747, 748, 749, 750, 751, 752, 753, 754, 755, 756, 757, 758, 759, 760, 761, 762, 763, 764, 765, 766, 767, 768, 769, 770, 771, 772, 773, 774, 775, 776, 777, 778, 779, 780, 781, 782, 783, 784, 785, 786, 787, 788, 789, 790, 791, 792, 793, 794, 795, 796, 797, 798, 799, 800, 801, 802, 803, 804, 805, 806, 807, 808, 809, 810, 811, 812, 813, 814, 815, 816, 817, 818, 819, 820, 821, 822, 823, 824, 825, 826, 827, 828, 829, 830, 831, 832, 833, 834, 835, 836, 837, 838, 839, 840, 841, 842, 843, 844, 845, 846, 847, 848, 849, 850, 851, 852, 853, 854, 855, 856, 857, 858, 859, 860, 861, 862, 863, 864, 865, 866, 867, 868, 869, 870, 871, 872, 873, 874, 875, 876, 877, 878, 879, 880, 881, 882, 883, 884, 885, 886, 887, 888, 889, 890, 891, 892, 893, 894, 895, 896, 897, 898, 899, 900, 901, 902, 903, 904, 905, 906, 907, 908, 909, 910, 911, 912, 913, 914, 915, 916, 917, 918, 919, 920, 921, 922, 923, 924, 925, 926, 927, 928, 929, 930, 931, 932, 933, 934, 935, 936, 937, 938, 939, 940, 941, 942, 943, 944, 945, 946, 947, 948, 949, 950, 951, 952, 953, 954, 955, 956, 957, 958, 959, 960, 961, 962, 963, 964, 965, 966, 967, 968, 969, 970, 971, 972, 973, 974, 975, 976, 977, 978, 979, 980, 981, 982, 983, 984, 985, 986, 987, 988, 989, 990, 991, 992, 993, 994, 995, 996, 997, 998, 999, 1000

MAIN CONTRACTOR :
Gammon

STRUCTURAL ENGINEER :
ARUP

FACADE CONSULTANT:
MEINHARDT

NOTE :
1. ALL DIMENSIONS ARE IN mm.
2. ALL ELEVATIONS ARE VIEWED FROM OUTSIDE.
3. ALL DIMENSIONS TO BE VERIFIED ON SITE BEFORE FABRICATION.

LEGEND :
X1 - DETAIL MARK NO.
X001 - REFER SHEET NO.
1. F.F.L. -- FINISHED FLOOR LEVEL
2. S.F.L. -- STRUCTURAL FLOOR LEVEL
3. (R) -- REVERSED DETAIL

NO.	DATE	REVISED	BY

JOB NO. : J-852
PROJECT : PROPOSED RESIDENTIAL DEVELOPMENT AT 139 - 147 ARGYLE STREET, NKIL 6005, 6035 R.P., 6036 R.P., 6037 R.P. & 6038 R.P.

TITLE :
DETAIL FOR Plenum Box

DATE : 05-Dec-19 SCALE : 1:2

DRAWN BY : MN CHECKED BY : DW

美特鋁質有限公司
MIDI ALUMINIUM FABRICATOR LTD.
Units 6-8, Sunray Industrial Centre, 1/F
610 Cha Kwo Ling Road, Kowloon
Tel:23489211-4 Fax:(852)2727666

DWG NO. : J852-SD-PB-5011 REV. : -

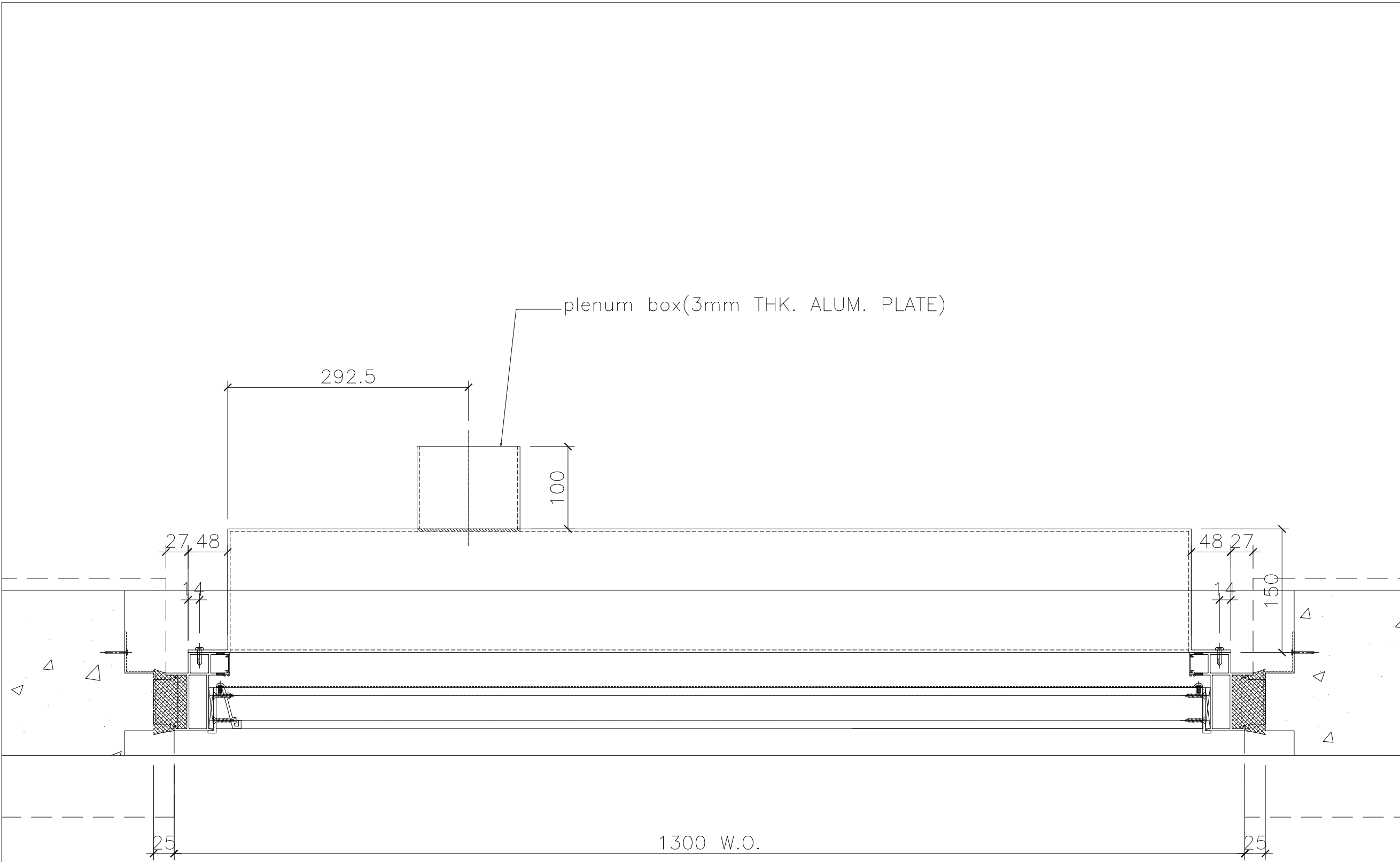

1 HORIZONTAL DETAIL
SCALE 1:1

OUTSIDE

B.D. REF :

CLIENT :

ARCHITECT :
AGC DESIGN LTD
 10/F, 107, Queen Mary Road, Hong Kong
 Tel: (852) 2771 1111 Fax: (852) 2771 1112 Email: agc@agc.com.hk

MAIN CONTRACTOR :
Gammon

STRUCTURAL ENGINEER :
ARUP

FACADE CONSULTANT:
MEINHARDT

NOTE :

1. ALL DIMENSIONS ARE IN mm.
2. ALL ELEVATIONS ARE VIEWED FROM OUTSIDE.
3. ALL DIMENSIONS TO BE VERIFIED ON SITE BEFORE FABRICATION.

LEGEND :

(x1) — DETAIL MARK NO.
 (x001) — REFER SHEET NO.

1. F.F.L. — FINISHED FLOOR LEVEL
2. S.F.L. — STRUCTURAL FLOOR LEVEL
3. (R) — REVERSED DETAIL
 — FIXING LOCATION
 — FIXING LUG LOCATION

GLASS LEGEND

GL01 — 8mm+12mm AIR GAP+10mm THK. I.G.U.
 GL01a — 8mm+9mm AIR GAP+12mm THK. I.G.U.
 GL03 — 6mm+12mm AIR GAP+6mm THK. I.G.U.
 GL04 — 10mm THK. TEMPERED GLASS (PROTECTIVE BARRIER)
 GL05 — 6mm+12mm AIR GAP+8mm THK. I.G.U.

NO.	DATE	REVISED	BY

JOB NO. : J-852

PROJECT :
 PROPOSED RESIDENTIAL DEVELOPMENT
 AT 139 - 147 ARGYLE STREET,
 NKIL 6005, 6035 R.P., 6036 R.P.,
 6037 R.P. & 6038 R.P.

TITLE :
 DETAIL FOR
 Plenum Box

DATE : 05-Dec-19 SCALE : 1:2

DRAWN BY : MN CHECKED BY : DW

美特鋁質有限公司
MIDI ALUMINIUM FABRICATOR LTD.
 Units 6-8, Sunray Industrial Centre, 1/F
 610 Cha Kwo Ling Road, Kowloon
 Tel:23489211-4 Fax:(852)2727666

DWG NO. : J852-SD-PB-5012 REV. : -

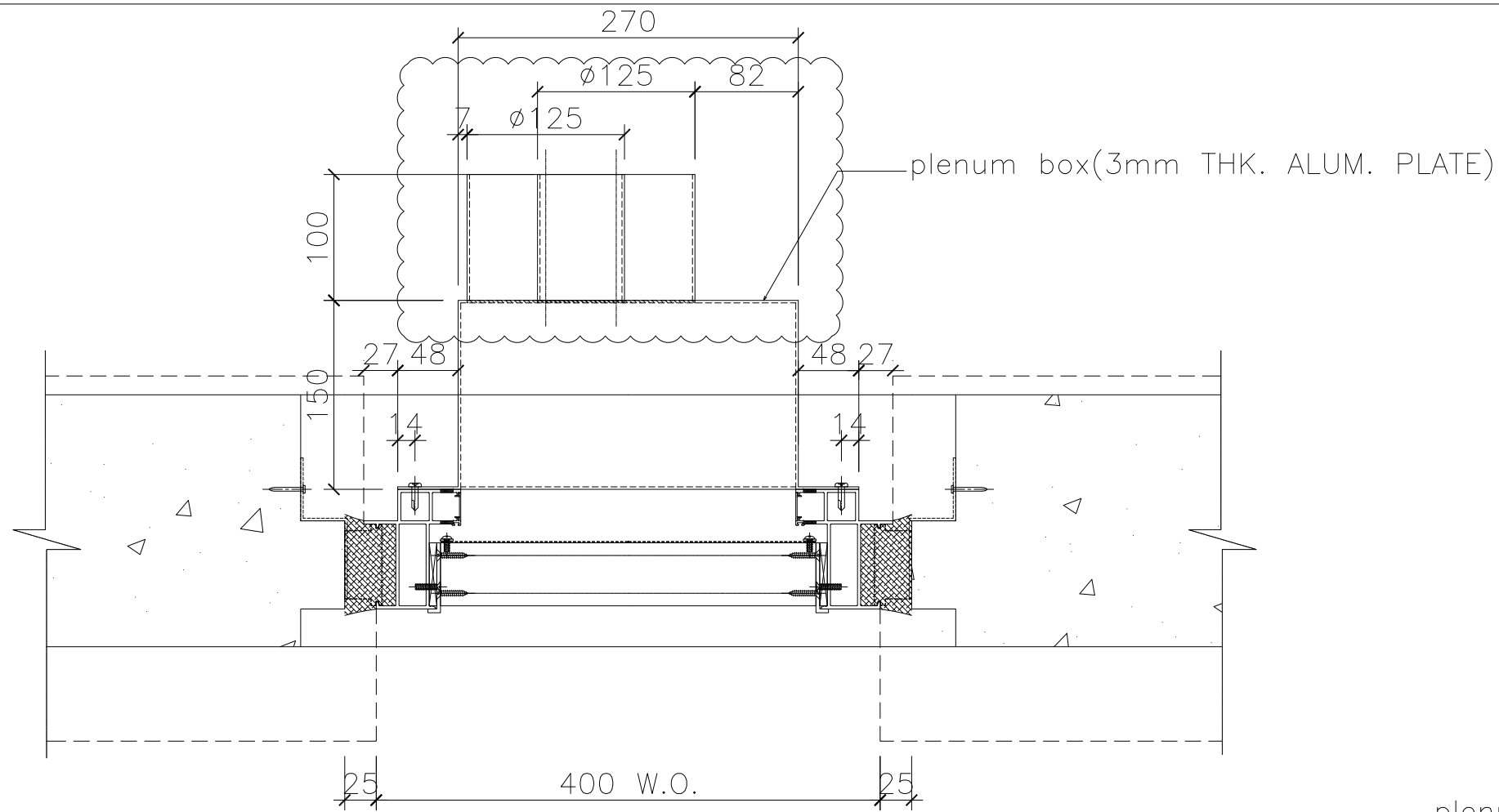

1 HORIZONTAL DETAIL SCALE 1:1 OUTSIDE

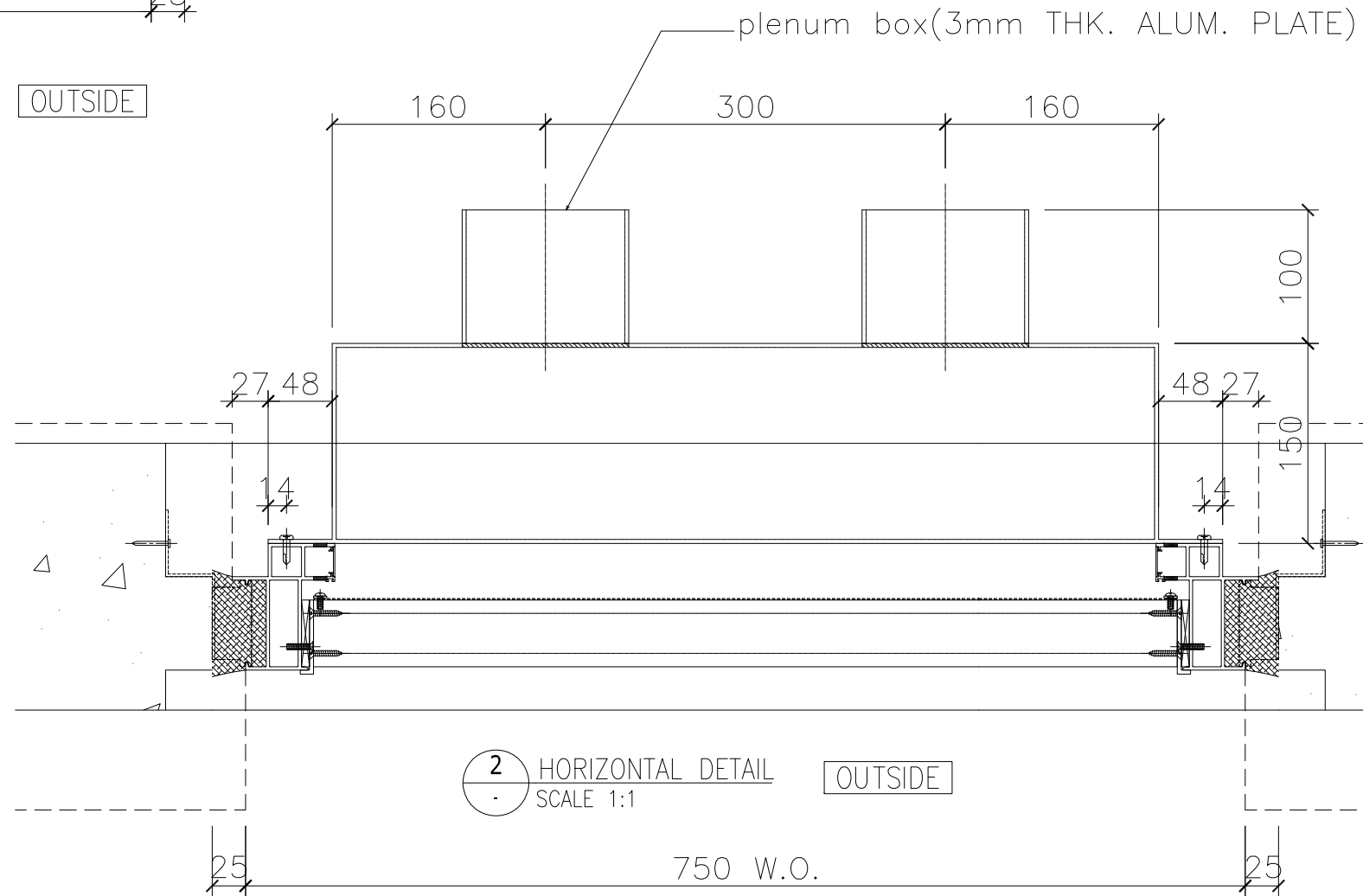

2 HORIZONTAL DETAIL SCALE 1:1 OUTSIDE

B.D. REF :

CLIENT :

ARCHITECT :
AGC DESIGN LTD
 101, 102, 103, 104, 105, 106, 107, 108, 109, 110, 111, 112, 113, 114, 115, 116, 117, 118, 119, 120, 121, 122, 123, 124, 125, 126, 127, 128, 129, 130, 131, 132, 133, 134, 135, 136, 137, 138, 139, 140, 141, 142, 143, 144, 145, 146, 147, 148, 149, 150, 151, 152, 153, 154, 155, 156, 157, 158, 159, 160, 161, 162, 163, 164, 165, 166, 167, 168, 169, 170, 171, 172, 173, 174, 175, 176, 177, 178, 179, 180, 181, 182, 183, 184, 185, 186, 187, 188, 189, 190, 191, 192, 193, 194, 195, 196, 197, 198, 199, 200, 201, 202, 203, 204, 205, 206, 207, 208, 209, 210, 211, 212, 213, 214, 215, 216, 217, 218, 219, 220, 221, 222, 223, 224, 225, 226, 227, 228, 229, 230, 231, 232, 233, 234, 235, 236, 237, 238, 239, 240, 241, 242, 243, 244, 245, 246, 247, 248, 249, 250, 251, 252, 253, 254, 255, 256, 257, 258, 259, 260, 261, 262, 263, 264, 265, 266, 267, 268, 269, 270, 271, 272, 273, 274, 275, 276, 277, 278, 279, 280, 281, 282, 283, 284, 285, 286, 287, 288, 289, 290, 291, 292, 293, 294, 295, 296, 297, 298, 299, 300, 301, 302, 303, 304, 305, 306, 307, 308, 309, 310, 311, 312, 313, 314, 315, 316, 317, 318, 319, 320, 321, 322, 323, 324, 325, 326, 327, 328, 329, 330, 331, 332, 333, 334, 335, 336, 337, 338, 339, 340, 341, 342, 343, 344, 345, 346, 347, 348, 349, 350, 351, 352, 353, 354, 355, 356, 357, 358, 359, 360, 361, 362, 363, 364, 365, 366, 367, 368, 369, 370, 371, 372, 373, 374, 375, 376, 377, 378, 379, 380, 381, 382, 383, 384, 385, 386, 387, 388, 389, 390, 391, 392, 393, 394, 395, 396, 397, 398, 399, 400, 401, 402, 403, 404, 405, 406, 407, 408, 409, 410, 411, 412, 413, 414, 415, 416, 417, 418, 419, 420, 421, 422, 423, 424, 425, 426, 427, 428, 429, 430, 431, 432, 433, 434, 435, 436, 437, 438, 439, 440, 441, 442, 443, 444, 445, 446, 447, 448, 449, 450, 451, 452, 453, 454, 455, 456, 457, 458, 459, 460, 461, 462, 463, 464, 465, 466, 467, 468, 469, 470, 471, 472, 473, 474, 475, 476, 477, 478, 479, 480, 481, 482, 483, 484, 485, 486, 487, 488, 489, 490, 491, 492, 493, 494, 495, 496, 497, 498, 499, 500, 501, 502, 503, 504, 505, 506, 507, 508, 509, 510, 511, 512, 513, 514, 515, 516, 517, 518, 519, 520, 521, 522, 523, 524, 525, 526, 527, 528, 529, 530, 531, 532, 533, 534, 535, 536, 537, 538, 539, 540, 541, 542, 543, 544, 545, 546, 547, 548, 549, 550, 551, 552, 553, 554, 555, 556, 557, 558, 559, 560, 561, 562, 563, 564, 565, 566, 567, 568, 569, 570, 571, 572, 573, 574, 575, 576, 577, 578, 579, 580, 581, 582, 583, 584, 585, 586, 587, 588, 589, 590, 591, 592, 593, 594, 595, 596, 597, 598, 599, 600, 601, 602, 603, 604, 605, 606, 607, 608, 609, 610, 611, 612, 613, 614, 615, 616, 617, 618, 619, 620, 621, 622, 623, 624, 625, 626, 627, 628, 629, 630, 631, 632, 633, 634, 635, 636, 637, 638, 639, 640, 641, 642, 643, 644, 645, 646, 647, 648, 649, 650, 651, 652, 653, 654, 655, 656, 657, 658, 659, 660, 661, 662, 663, 664, 665, 666, 667, 668, 669, 670, 671, 672, 673, 674, 675, 676, 677, 678, 679, 680, 681, 682, 683, 684, 685, 686, 687, 688, 689, 690, 691, 692, 693, 694, 695, 696, 697, 698, 699, 700, 701, 702, 703, 704, 705, 706, 707, 708, 709, 710, 711, 712, 713, 714, 715, 716, 717, 718, 719, 720, 721, 722, 723, 724, 725, 726, 727, 728, 729, 730, 731, 732, 733, 734, 735, 736, 737, 738, 739, 740, 741, 742, 743, 744, 745, 746, 747, 748, 749, 750, 751, 752, 753, 754, 755, 756, 757, 758, 759, 760, 761, 762, 763, 764, 765, 766, 767, 768, 769, 770, 771, 772, 773, 774, 775, 776, 777, 778, 779, 780, 781, 782, 783, 784, 785, 786, 787, 788, 789, 790, 791, 792, 793, 794, 795, 796, 797, 798, 799, 800, 801, 802, 803, 804, 805, 806, 807, 808, 809, 810, 811, 812, 813, 814, 815, 816, 817, 818, 819, 820, 821, 822, 823, 824, 825, 826, 827, 828, 829, 830, 831, 832, 833, 834, 835, 836, 837, 838, 839, 840, 841, 842, 843, 844, 845, 846, 847, 848, 849, 850, 851, 852, 853, 854, 855, 856, 857, 858, 859, 860, 861, 862, 863, 864, 865, 866, 867, 868, 869, 870, 871, 872, 873, 874, 875, 876, 877, 878, 879, 880, 881, 882, 883, 884, 885, 886, 887, 888, 889, 890, 891, 892, 893, 894, 895, 896, 897, 898, 899, 900, 901, 902, 903, 904, 905, 906, 907, 908, 909, 910, 911, 912, 913, 914, 915, 916, 917, 918, 919, 920, 921, 922, 923, 924, 925, 926, 927, 928, 929, 930, 931, 932, 933, 934, 935, 936, 937, 938, 939, 940, 941, 942, 943, 944, 945, 946, 947, 948, 949, 950, 951, 952, 953, 954, 955, 956, 957, 958, 959, 960, 961, 962, 963, 964, 965, 966, 967, 968, 969, 970, 971, 972, 973, 974, 975, 976, 977, 978, 979, 980, 981, 982, 983, 984, 985, 986, 987, 988, 989, 990, 991, 992, 993, 994, 995, 996, 997, 998, 999, 1000

MAIN CONTRACTOR :
Gammon

STRUCTURAL ENGINEER :
ARUP

FACADE CONSULTANT:
MEINHARDT

NOTE :
 1. ALL DIMENSIONS ARE IN mm.
 2. ALL ELEVATIONS ARE VIEWED FROM OUTSIDE.
 3. ALL DIMENSIONS TO BE VERIFIED ON SITE BEFORE FABRICATION.

LEGEND :
 (X1) --- DETAIL MARK NO.
 (X001) --- REFER SHEET NO.
 1. F.F.L. --- FINISHED FLOOR LEVEL
 2. S.F.L. --- STRUCTURAL FLOOR LEVEL
 3. (R) --- REVERSED DETAIL
 --- FIXING LOCATION
 --- FIXING LUG LOCATION
 GLASS LEGEND
 GL01 --- 8mm+12mm AIR GAP+10mm THK. I.G.U.
 GL01a --- 8mm+9mm AIR GAP+12mm THK. I.G.U.
 GL03 --- 6mm+12mm AIR GAP+6mm THK. I.G.U.
 GL04 --- 10mm THK. TEMPERED GLASS (PROTECTIVE BARRIER)
 GL05 --- 6mm+12mm AIR GAP+8mm THK. I.G.U.

NO.	DATE	REVISION	BY
A	06/01/2021	REVISION SUBJECT TO ARCH.COMMENT	lvn

JOB NO. : J-852
 PROJECT : PROPOSED RESIDENTIAL DEVELOPMENT
 AT 139 - 147 ARGYLE STREET,
 NKIL 6005, 6035 R.P., 6036 R.P.,
 6037 R.P. & 6038 R.P.

TITLE :
 DETAIL FOR
 Plenum Box

DATE : 05-Dec-19 SCALE : 1:2
 DRAWN BY : MN CHECKED BY : DW

美特鋁質有限公司
MIDI ALUMINIUM FABRICATOR LTD.
 Units 6-8, Sunray Industrial Centre, 1/F
 610 Cha Kwo Ling Road, Kowloon
 Tel:23489211-4 Fax:(852)2727666

DWG NO. : J852-SD-PB-5013 REV. : A

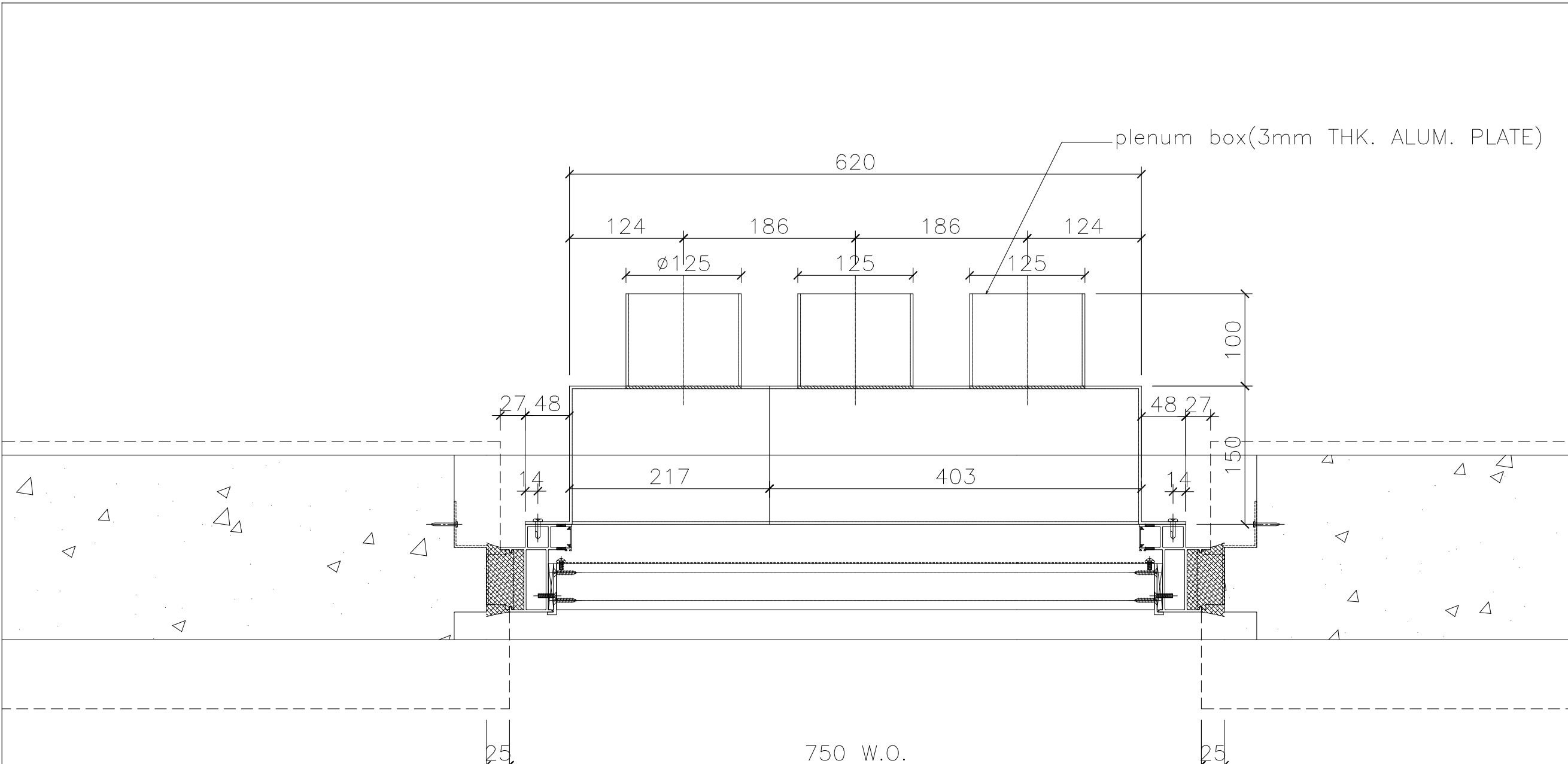

1 HORIZONTAL DETAIL OUTSIDE
SCALE 1:1

B.D. REF :

CLIENT :

ARCHITECT :
AGC DESIGN LTD

MAIN CONTRACTOR :
Gammon

STRUCTURAL ENGINEER :
ARUP

FACADE CONSULTANT:
MEINHARDT

NOTE :

1. ALL DIMENSIONS ARE IN mm.
2. ALL ELEVATIONS ARE VIEWED FROM OUTSIDE.
3. ALL DIMENSIONS TO BE VERIFIED ON SITE BEFORE FABRICATION.

LEGEND :

x1 — DETAIL MARK NO.
x001 — REFER SHEET NO.

1. F.F.L. -- FINISHED FLOOR LEVEL
2. S.F.L. -- STRUCTURAL FLOOR LEVEL
3. (R) -- REVERSED DETAIL
- (L) -- FIXING LOCATION
- (L) -- FIXING LUG LOCATION

GLASS LEGEND

GL01 -- 8mm+12mm AIR GAP+10mm THK. I.G.U.
GL01a -- 8mm+9mm AIR GAP+12mm THK. I.G.U.
GL03 -- 6mm+12mm AIR GAP+6mm THK. I.G.U.
GL04 -- 10mm THK. TEMPERED GLASS (PROTECTIVE BARRIER)
GL05 -- 6mm+12mm AIR GAP+8mm THK. I.G.U.

NO.	DATE	REVISED	BY
JOB NO. : J-852			
PROJECT : PROPOSED RESIDENTIAL DEVELOPMENT AT 139 - 147 ARGYLE STREET, NKIL 6005, 6035 R.P., 6036 R.P., 6037 R.P. & 6038 R.P.			
TITLE : DETAIL FOR Plenum Box			
DATE : 05-Dec-19		SCALE : 1:2	
DRAWN BY : MN		CHECKED BY : DW	
<p>美特鋁質有限公司 MIDI ALUMINIUM FABRICATOR LTD. Units 6-8, Sunray Industrial Centre, 1/F 610 Cha Kwo Ling Road, Kowloon Tel:23489211-4 Fax:(852)2727666</p>			
DWG NO. : J852-SD-PB-5014			REV. : -

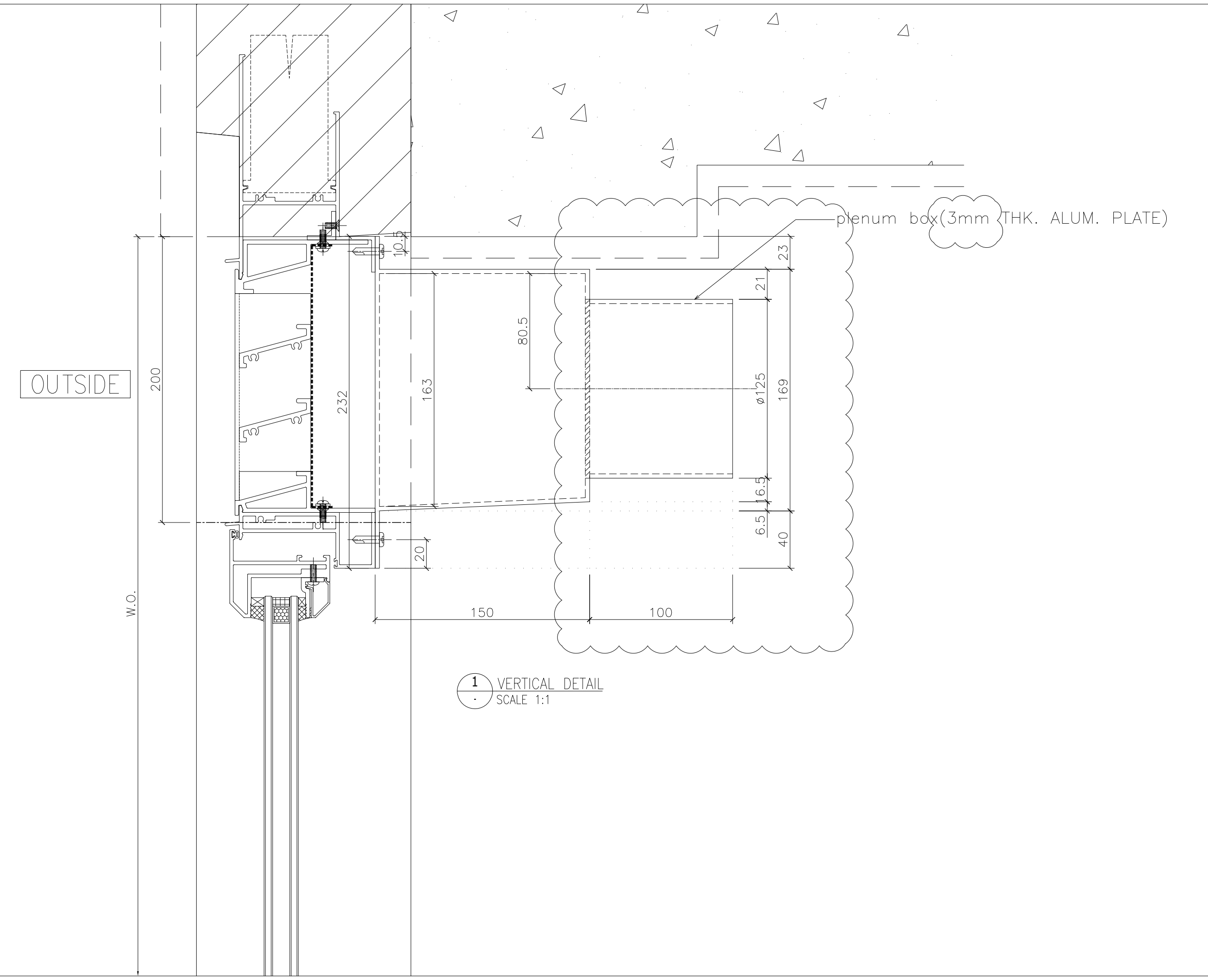

plenum box(3mm THK. ALUM. PLATE)

OUTSIDE

W.O.

1 VERTICAL DETAIL
SCALE 1:1

B.D. REF :

CLIENT :

ARCHITECT :
AGC DESIGN LTD
 101, 102, 103, 104, 105, 106, 107, 108, 109, 110, 111, 112, 113, 114, 115, 116, 117, 118, 119, 120, 121, 122, 123, 124, 125, 126, 127, 128, 129, 130, 131, 132, 133, 134, 135, 136, 137, 138, 139, 140, 141, 142, 143, 144, 145, 146, 147, 148, 149, 150, 151, 152, 153, 154, 155, 156, 157, 158, 159, 160, 161, 162, 163, 164, 165, 166, 167, 168, 169, 170, 171, 172, 173, 174, 175, 176, 177, 178, 179, 180, 181, 182, 183, 184, 185, 186, 187, 188, 189, 190, 191, 192, 193, 194, 195, 196, 197, 198, 199, 200, 201, 202, 203, 204, 205, 206, 207, 208, 209, 210, 211, 212, 213, 214, 215, 216, 217, 218, 219, 220, 221, 222, 223, 224, 225, 226, 227, 228, 229, 230, 231, 232, 233, 234, 235, 236, 237, 238, 239, 240, 241, 242, 243, 244, 245, 246, 247, 248, 249, 250, 251, 252, 253, 254, 255, 256, 257, 258, 259, 260, 261, 262, 263, 264, 265, 266, 267, 268, 269, 270, 271, 272, 273, 274, 275, 276, 277, 278, 279, 280, 281, 282, 283, 284, 285, 286, 287, 288, 289, 290, 291, 292, 293, 294, 295, 296, 297, 298, 299, 300, 301, 302, 303, 304, 305, 306, 307, 308, 309, 310, 311, 312, 313, 314, 315, 316, 317, 318, 319, 320, 321, 322, 323, 324, 325, 326, 327, 328, 329, 330, 331, 332, 333, 334, 335, 336, 337, 338, 339, 340, 341, 342, 343, 344, 345, 346, 347, 348, 349, 350, 351, 352, 353, 354, 355, 356, 357, 358, 359, 360, 361, 362, 363, 364, 365, 366, 367, 368, 369, 370, 371, 372, 373, 374, 375, 376, 377, 378, 379, 380, 381, 382, 383, 384, 385, 386, 387, 388, 389, 390, 391, 392, 393, 394, 395, 396, 397, 398, 399, 400, 401, 402, 403, 404, 405, 406, 407, 408, 409, 410, 411, 412, 413, 414, 415, 416, 417, 418, 419, 420, 421, 422, 423, 424, 425, 426, 427, 428, 429, 430, 431, 432, 433, 434, 435, 436, 437, 438, 439, 440, 441, 442, 443, 444, 445, 446, 447, 448, 449, 450, 451, 452, 453, 454, 455, 456, 457, 458, 459, 460, 461, 462, 463, 464, 465, 466, 467, 468, 469, 470, 471, 472, 473, 474, 475, 476, 477, 478, 479, 480, 481, 482, 483, 484, 485, 486, 487, 488, 489, 490, 491, 492, 493, 494, 495, 496, 497, 498, 499, 500, 501, 502, 503, 504, 505, 506, 507, 508, 509, 510, 511, 512, 513, 514, 515, 516, 517, 518, 519, 520, 521, 522, 523, 524, 525, 526, 527, 528, 529, 530, 531, 532, 533, 534, 535, 536, 537, 538, 539, 540, 541, 542, 543, 544, 545, 546, 547, 548, 549, 550, 551, 552, 553, 554, 555, 556, 557, 558, 559, 560, 561, 562, 563, 564, 565, 566, 567, 568, 569, 570, 571, 572, 573, 574, 575, 576, 577, 578, 579, 580, 581, 582, 583, 584, 585, 586, 587, 588, 589, 590, 591, 592, 593, 594, 595, 596, 597, 598, 599, 600, 601, 602, 603, 604, 605, 606, 607, 608, 609, 610, 611, 612, 613, 614, 615, 616, 617, 618, 619, 620, 621, 622, 623, 624, 625, 626, 627, 628, 629, 630, 631, 632, 633, 634, 635, 636, 637, 638, 639, 640, 641, 642, 643, 644, 645, 646, 647, 648, 649, 650, 651, 652, 653, 654, 655, 656, 657, 658, 659, 660, 661, 662, 663, 664, 665, 666, 667, 668, 669, 670, 671, 672, 673, 674, 675, 676, 677, 678, 679, 680, 681, 682, 683, 684, 685, 686, 687, 688, 689, 690, 691, 692, 693, 694, 695, 696, 697, 698, 699, 700, 701, 702, 703, 704, 705, 706, 707, 708, 709, 710, 711, 712, 713, 714, 715, 716, 717, 718, 719, 720, 721, 722, 723, 724, 725, 726, 727, 728, 729, 730, 731, 732, 733, 734, 735, 736, 737, 738, 739, 740, 741, 742, 743, 744, 745, 746, 747, 748, 749, 750, 751, 752, 753, 754, 755, 756, 757, 758, 759, 760, 761, 762, 763, 764, 765, 766, 767, 768, 769, 770, 771, 772, 773, 774, 775, 776, 777, 778, 779, 780, 781, 782, 783, 784, 785, 786, 787, 788, 789, 790, 791, 792, 793, 794, 795, 796, 797, 798, 799, 800, 801, 802, 803, 804, 805, 806, 807, 808, 809, 810, 811, 812, 813, 814, 815, 816, 817, 818, 819, 820, 821, 822, 823, 824, 825, 826, 827, 828, 829, 830, 831, 832, 833, 834, 835, 836, 837, 838, 839, 840, 841, 842, 843, 844, 845, 846, 847, 848, 849, 850, 851, 852, 853, 854, 855, 856, 857, 858, 859, 860, 861, 862, 863, 864, 865, 866, 867, 868, 869, 870, 871, 872, 873, 874, 875, 876, 877, 878, 879, 880, 881, 882, 883, 884, 885, 886, 887, 888, 889, 890, 891, 892, 893, 894, 895, 896, 897, 898, 899, 900, 901, 902, 903, 904, 905, 906, 907, 908, 909, 910, 911, 912, 913, 914, 915, 916, 917, 918, 919, 920, 921, 922, 923, 924, 925, 926, 927, 928, 929, 930, 931, 932, 933, 934, 935, 936, 937, 938, 939, 940, 941, 942, 943, 944, 945, 946, 947, 948, 949, 950, 951, 952, 953, 954, 955, 956, 957, 958, 959, 960, 961, 962, 963, 964, 965, 966, 967, 968, 969, 970, 971, 972, 973, 974, 975, 976, 977, 978, 979, 980, 981, 982, 983, 984, 985, 986, 987, 988, 989, 990, 991, 992, 993, 994, 995, 996, 997, 998, 999, 1000

MAIN CONTRACTOR :
Gammon

STRUCTURAL ENGINEER :
ARUP

FACADE CONSULTANT:
MEINHARDT

NOTE :

1. ALL DIMENSIONS ARE IN mm.
2. ALL ELEVATIONS ARE VIEWED FROM OUTSIDE.
3. ALL DIMENSIONS TO BE VERIFIED ON SITE BEFORE FABRICATION.

LEGEND :

x1 — DETAIL MARK NO.
 x001 — REFER SHEET NO.

1. F.F.L. -- FINISHED FLOOR LEVEL
2. S.F.L. -- STRUCTURAL FLOOR LEVEL
3. (R) -- REVERSED DETAIL
4. ▲ -- FIXING LOCATION
5. △ -- FIXING LUG LOCATION
6. GLASS LEGEND
 GL01 -- 8mm+12mm AIR GAP+10mm THK. I.G.U.
 GL01a -- 8mm+9mm AIR GAP+12mm THK. I.G.U.
 GL02 -- 10mm THK. TEMPERED GLASS (SPANDREL GLASS)
 GL03 -- 6mm+12mm AIR GAP+6mm THK. I.G.U.
 GL04 -- 10mm THK. TEMPERED GLASS (PROTECTIVE BARRIER)
 GL05 -- 6mm+12mm AIR GAP+8mm THK. I.G.U.

NO.	DATE	REVISION	BY
A	09/12/2020	REVISION SUBJECT TO ARCH.COMMENT	lvn

JOB NO. : J-852

PROJECT :
 PROPOSED RESIDENTIAL DEVELOPMENT
 AT 139 - 147 ARGYLE STREET,
 NKIL 6005, 6035 R.P., 6036 R.P.,
 6037 R.P. & 6038 R.P.

TITLE :
 DETAIL FOR
 Plenum Box

DATE : 05-Dec-19 SCALE : 1:2

DRAWN BY : MN CHECKED BY : DW

美特鋁質有限公司
MIDI ALUMINIUM FABRICATOR LTD.
 Units 6-8, Sunray Industrial Centre, 1/F
 610 Cha Kwo Ling Road, Kowloon
 Tel:23489211-4 Fax:(852)2727666

DWG NO. : J852-SD-PB-6001 REV. : A

OUTSIDE

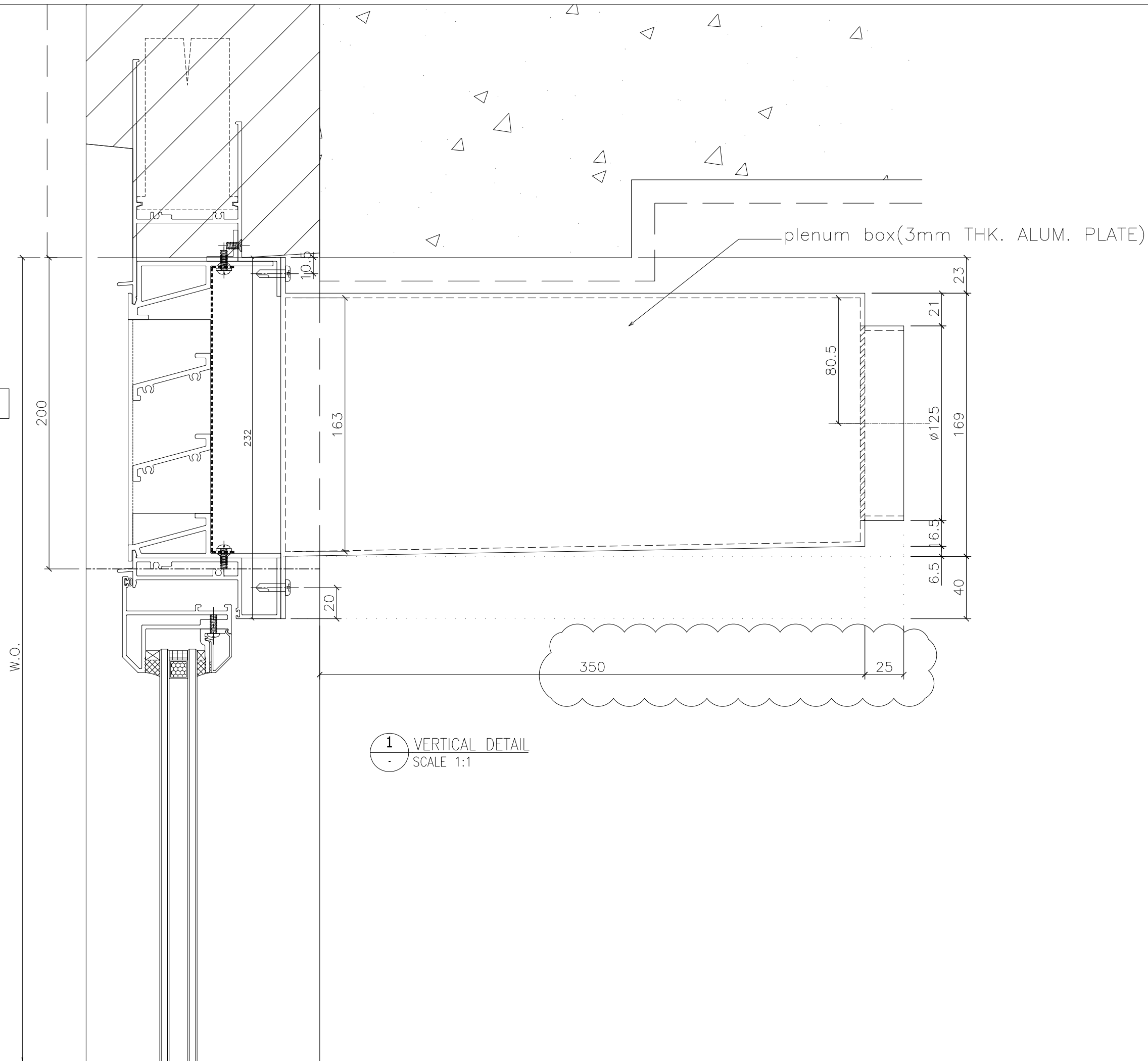

1 VERTICAL DETAIL
SCALE 1:1

B.D. REF :

CLIENT :

ARCHITECT :
AGC DESIGN LTD
 101, 102, 103, 104, 105, 106, 107, 108, 109, 110, 111, 112, 113, 114, 115, 116, 117, 118, 119, 120, 121, 122, 123, 124, 125, 126, 127, 128, 129, 130, 131, 132, 133, 134, 135, 136, 137, 138, 139, 140, 141, 142, 143, 144, 145, 146, 147, 148, 149, 150, 151, 152, 153, 154, 155, 156, 157, 158, 159, 160, 161, 162, 163, 164, 165, 166, 167, 168, 169, 170, 171, 172, 173, 174, 175, 176, 177, 178, 179, 180, 181, 182, 183, 184, 185, 186, 187, 188, 189, 190, 191, 192, 193, 194, 195, 196, 197, 198, 199, 200, 201, 202, 203, 204, 205, 206, 207, 208, 209, 210, 211, 212, 213, 214, 215, 216, 217, 218, 219, 220, 221, 222, 223, 224, 225, 226, 227, 228, 229, 230, 231, 232, 233, 234, 235, 236, 237, 238, 239, 240, 241, 242, 243, 244, 245, 246, 247, 248, 249, 250, 251, 252, 253, 254, 255, 256, 257, 258, 259, 260, 261, 262, 263, 264, 265, 266, 267, 268, 269, 270, 271, 272, 273, 274, 275, 276, 277, 278, 279, 280, 281, 282, 283, 284, 285, 286, 287, 288, 289, 290, 291, 292, 293, 294, 295, 296, 297, 298, 299, 300, 301, 302, 303, 304, 305, 306, 307, 308, 309, 310, 311, 312, 313, 314, 315, 316, 317, 318, 319, 320, 321, 322, 323, 324, 325, 326, 327, 328, 329, 330, 331, 332, 333, 334, 335, 336, 337, 338, 339, 340, 341, 342, 343, 344, 345, 346, 347, 348, 349, 350, 351, 352, 353, 354, 355, 356, 357, 358, 359, 360, 361, 362, 363, 364, 365, 366, 367, 368, 369, 370, 371, 372, 373, 374, 375, 376, 377, 378, 379, 380, 381, 382, 383, 384, 385, 386, 387, 388, 389, 390, 391, 392, 393, 394, 395, 396, 397, 398, 399, 400, 401, 402, 403, 404, 405, 406, 407, 408, 409, 410, 411, 412, 413, 414, 415, 416, 417, 418, 419, 420, 421, 422, 423, 424, 425, 426, 427, 428, 429, 430, 431, 432, 433, 434, 435, 436, 437, 438, 439, 440, 441, 442, 443, 444, 445, 446, 447, 448, 449, 450, 451, 452, 453, 454, 455, 456, 457, 458, 459, 460, 461, 462, 463, 464, 465, 466, 467, 468, 469, 470, 471, 472, 473, 474, 475, 476, 477, 478, 479, 480, 481, 482, 483, 484, 485, 486, 487, 488, 489, 490, 491, 492, 493, 494, 495, 496, 497, 498, 499, 500, 501, 502, 503, 504, 505, 506, 507, 508, 509, 510, 511, 512, 513, 514, 515, 516, 517, 518, 519, 520, 521, 522, 523, 524, 525, 526, 527, 528, 529, 530, 531, 532, 533, 534, 535, 536, 537, 538, 539, 540, 541, 542, 543, 544, 545, 546, 547, 548, 549, 550, 551, 552, 553, 554, 555, 556, 557, 558, 559, 560, 561, 562, 563, 564, 565, 566, 567, 568, 569, 570, 571, 572, 573, 574, 575, 576, 577, 578, 579, 580, 581, 582, 583, 584, 585, 586, 587, 588, 589, 590, 591, 592, 593, 594, 595, 596, 597, 598, 599, 600, 601, 602, 603, 604, 605, 606, 607, 608, 609, 610, 611, 612, 613, 614, 615, 616, 617, 618, 619, 620, 621, 622, 623, 624, 625, 626, 627, 628, 629, 630, 631, 632, 633, 634, 635, 636, 637, 638, 639, 640, 641, 642, 643, 644, 645, 646, 647, 648, 649, 650, 651, 652, 653, 654, 655, 656, 657, 658, 659, 660, 661, 662, 663, 664, 665, 666, 667, 668, 669, 670, 671, 672, 673, 674, 675, 676, 677, 678, 679, 680, 681, 682, 683, 684, 685, 686, 687, 688, 689, 690, 691, 692, 693, 694, 695, 696, 697, 698, 699, 700, 701, 702, 703, 704, 705, 706, 707, 708, 709, 710, 711, 712, 713, 714, 715, 716, 717, 718, 719, 720, 721, 722, 723, 724, 725, 726, 727, 728, 729, 730, 731, 732, 733, 734, 735, 736, 737, 738, 739, 740, 741, 742, 743, 744, 745, 746, 747, 748, 749, 750, 751, 752, 753, 754, 755, 756, 757, 758, 759, 760, 761, 762, 763, 764, 765, 766, 767, 768, 769, 770, 771, 772, 773, 774, 775, 776, 777, 778, 779, 780, 781, 782, 783, 784, 785, 786, 787, 788, 789, 790, 791, 792, 793, 794, 795, 796, 797, 798, 799, 800, 801, 802, 803, 804, 805, 806, 807, 808, 809, 810, 811, 812, 813, 814, 815, 816, 817, 818, 819, 820, 821, 822, 823, 824, 825, 826, 827, 828, 829, 830, 831, 832, 833, 834, 835, 836, 837, 838, 839, 840, 841, 842, 843, 844, 845, 846, 847, 848, 849, 850, 851, 852, 853, 854, 855, 856, 857, 858, 859, 860, 861, 862, 863, 864, 865, 866, 867, 868, 869, 870, 871, 872, 873, 874, 875, 876, 877, 878, 879, 880, 881, 882, 883, 884, 885, 886, 887, 888, 889, 890, 891, 892, 893, 894, 895, 896, 897, 898, 899, 900, 901, 902, 903, 904, 905, 906, 907, 908, 909, 910, 911, 912, 913, 914, 915, 916, 917, 918, 919, 920, 921, 922, 923, 924, 925, 926, 927, 928, 929, 930, 931, 932, 933, 934, 935, 936, 937, 938, 939, 940, 941, 942, 943, 944, 945, 946, 947, 948, 949, 950, 951, 952, 953, 954, 955, 956, 957, 958, 959, 960, 961, 962, 963, 964, 965, 966, 967, 968, 969, 970, 971, 972, 973, 974, 975, 976, 977, 978, 979, 980, 981, 982, 983, 984, 985, 986, 987, 988, 989, 990, 991, 992, 993, 994, 995, 996, 997, 998, 999, 1000

MAIN CONTRACTOR :
Gammon

STRUCTURAL ENGINEER :
ARUP

FAÇADE CONSULTANT:
MEINHARDT

NOTE :
 1. ALL DIMENSIONS ARE IN mm.
 2. ALL ELEVATIONS ARE VIEWED FROM OUTSIDE.
 3. ALL DIMENSIONS TO BE VERIFIED ON SITE BEFORE FABRICATION.

LEGEND :
 (x1) --- DETAIL MARK NO.
 (x001) --- REFER SHEET NO.
 1. F.F.L. --- FINISHED FLOOR LEVEL
 2. S.F.L. --- STRUCTURAL FLOOR LEVEL
 3. (R) --- REVERSED DETAIL
 4. ▲ --- FIXING LOCATION
 5. △ --- FIXING LUG LOCATION
 6. GLASS LEGEND
 GL01 --- 8mm+12mm AIR GAP+10mm THK. I.G.U.
 GL01a --- 8mm+9mm AIR GAP+12mm THK. I.G.U.
 GL02 --- 10mm THK. TEMPERED GLASS (SPANDREL GLASS)
 GL03 --- 6mm+12mm AIR GAP+6mm THK. I.G.U.
 GL04 --- 10mm THK. TEMPERED GLASS (PROTECTIVE BARRIER)
 GL05 --- 6mm+12mm AIR GAP+8mm THK. I.G.U.

NO.	DATE	REVISION	BY
A	23/03/2021	REVISION SUBJECT TO ARCH.COMMENT	Ivan

JOB NO. : J-852
 PROJECT :
 PROPOSED RESIDENTIAL DEVELOPMENT
 AT 139 - 147 ARGYLE STREET,
 NKIL 6005, 6035 R.P., 6036 R.P.,
 6037 R.P. & 6038 R.P.

TITLE :
 DETAIL FOR
 Plenum Box

DATE : 05-Dec-19 SCALE : 1:2
 DRAWN BY : MN CHECKED BY : DW

美特鋁質有限公司
MIDI ALUMINIUM FABRICATOR LTD.
 Units 6-8, Sunray Industrial Centre, 1/F
 610 Cha Kwo Ling Road, Kowloon
 Tel:23489211-4 Fax:(852)2727666

DWG NO. : J852-SD-PB-6001a REV. : A

OUTSIDE

W.O.
200

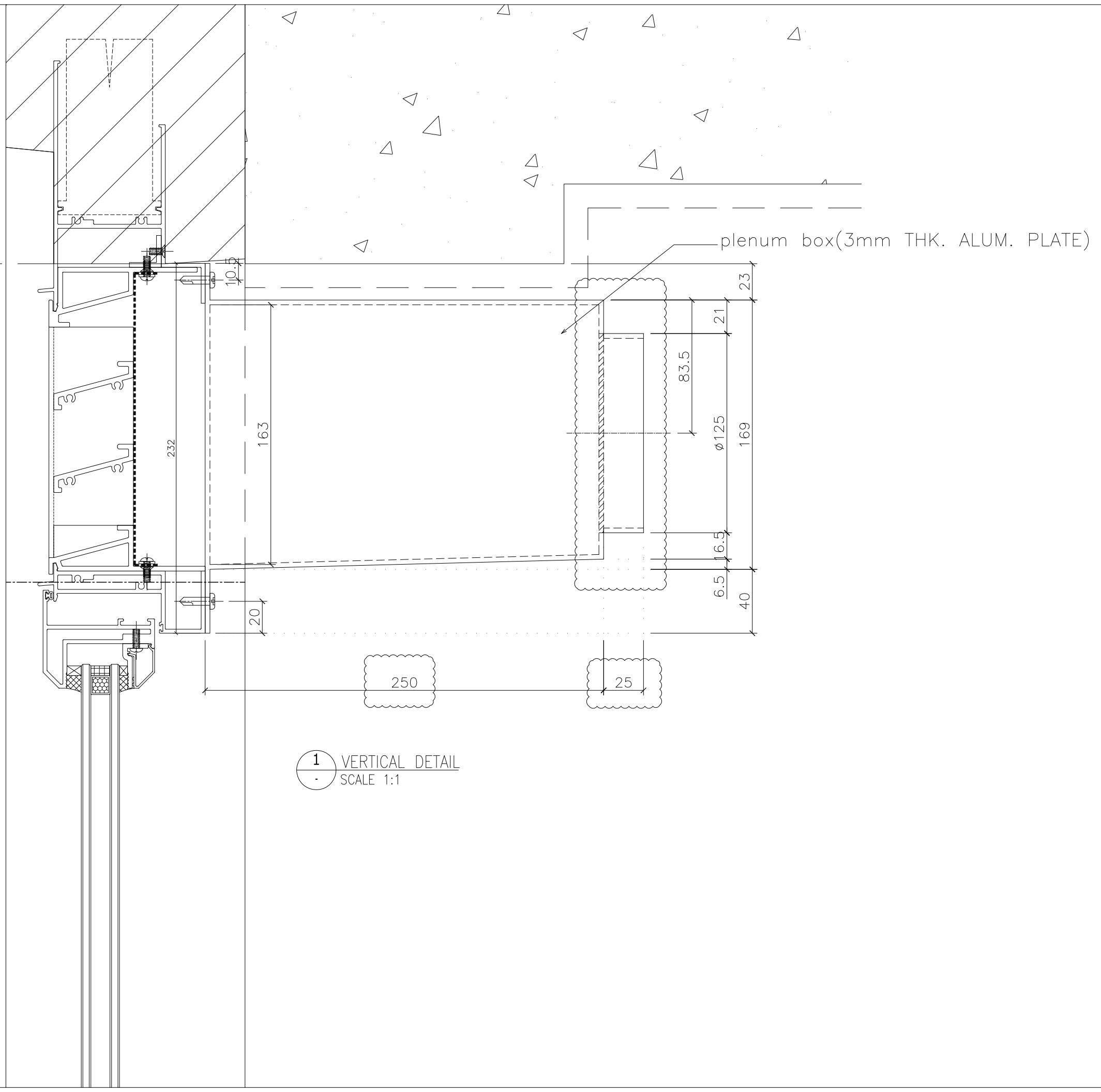

1 VERTICAL DETAIL
SCALE 1:1

B.D. REF :

CLIENT :

ARCHITECT :
AGC DESIGN LTD
 101, 102, 103, 104, 105, 106, 107, 108, 109, 110, 111, 112, 113, 114, 115, 116, 117, 118, 119, 120, 121, 122, 123, 124, 125, 126, 127, 128, 129, 130, 131, 132, 133, 134, 135, 136, 137, 138, 139, 140, 141, 142, 143, 144, 145, 146, 147, 148, 149, 150, 151, 152, 153, 154, 155, 156, 157, 158, 159, 160, 161, 162, 163, 164, 165, 166, 167, 168, 169, 170, 171, 172, 173, 174, 175, 176, 177, 178, 179, 180, 181, 182, 183, 184, 185, 186, 187, 188, 189, 190, 191, 192, 193, 194, 195, 196, 197, 198, 199, 200, 201, 202, 203, 204, 205, 206, 207, 208, 209, 210, 211, 212, 213, 214, 215, 216, 217, 218, 219, 220, 221, 222, 223, 224, 225, 226, 227, 228, 229, 230, 231, 232, 233, 234, 235, 236, 237, 238, 239, 240, 241, 242, 243, 244, 245, 246, 247, 248, 249, 250, 251, 252, 253, 254, 255, 256, 257, 258, 259, 260, 261, 262, 263, 264, 265, 266, 267, 268, 269, 270, 271, 272, 273, 274, 275, 276, 277, 278, 279, 280, 281, 282, 283, 284, 285, 286, 287, 288, 289, 290, 291, 292, 293, 294, 295, 296, 297, 298, 299, 300, 301, 302, 303, 304, 305, 306, 307, 308, 309, 310, 311, 312, 313, 314, 315, 316, 317, 318, 319, 320, 321, 322, 323, 324, 325, 326, 327, 328, 329, 330, 331, 332, 333, 334, 335, 336, 337, 338, 339, 340, 341, 342, 343, 344, 345, 346, 347, 348, 349, 350, 351, 352, 353, 354, 355, 356, 357, 358, 359, 360, 361, 362, 363, 364, 365, 366, 367, 368, 369, 370, 371, 372, 373, 374, 375, 376, 377, 378, 379, 380, 381, 382, 383, 384, 385, 386, 387, 388, 389, 390, 391, 392, 393, 394, 395, 396, 397, 398, 399, 400, 401, 402, 403, 404, 405, 406, 407, 408, 409, 410, 411, 412, 413, 414, 415, 416, 417, 418, 419, 420, 421, 422, 423, 424, 425, 426, 427, 428, 429, 430, 431, 432, 433, 434, 435, 436, 437, 438, 439, 440, 441, 442, 443, 444, 445, 446, 447, 448, 449, 450, 451, 452, 453, 454, 455, 456, 457, 458, 459, 460, 461, 462, 463, 464, 465, 466, 467, 468, 469, 470, 471, 472, 473, 474, 475, 476, 477, 478, 479, 480, 481, 482, 483, 484, 485, 486, 487, 488, 489, 490, 491, 492, 493, 494, 495, 496, 497, 498, 499, 500, 501, 502, 503, 504, 505, 506, 507, 508, 509, 510, 511, 512, 513, 514, 515, 516, 517, 518, 519, 520, 521, 522, 523, 524, 525, 526, 527, 528, 529, 530, 531, 532, 533, 534, 535, 536, 537, 538, 539, 540, 541, 542, 543, 544, 545, 546, 547, 548, 549, 550, 551, 552, 553, 554, 555, 556, 557, 558, 559, 560, 561, 562, 563, 564, 565, 566, 567, 568, 569, 570, 571, 572, 573, 574, 575, 576, 577, 578, 579, 580, 581, 582, 583, 584, 585, 586, 587, 588, 589, 590, 591, 592, 593, 594, 595, 596, 597, 598, 599, 600, 601, 602, 603, 604, 605, 606, 607, 608, 609, 610, 611, 612, 613, 614, 615, 616, 617, 618, 619, 620, 621, 622, 623, 624, 625, 626, 627, 628, 629, 630, 631, 632, 633, 634, 635, 636, 637, 638, 639, 640, 641, 642, 643, 644, 645, 646, 647, 648, 649, 650, 651, 652, 653, 654, 655, 656, 657, 658, 659, 660, 661, 662, 663, 664, 665, 666, 667, 668, 669, 670, 671, 672, 673, 674, 675, 676, 677, 678, 679, 680, 681, 682, 683, 684, 685, 686, 687, 688, 689, 690, 691, 692, 693, 694, 695, 696, 697, 698, 699, 700, 701, 702, 703, 704, 705, 706, 707, 708, 709, 710, 711, 712, 713, 714, 715, 716, 717, 718, 719, 720, 721, 722, 723, 724, 725, 726, 727, 728, 729, 730, 731, 732, 733, 734, 735, 736, 737, 738, 739, 740, 741, 742, 743, 744, 745, 746, 747, 748, 749, 750, 751, 752, 753, 754, 755, 756, 757, 758, 759, 760, 761, 762, 763, 764, 765, 766, 767, 768, 769, 770, 771, 772, 773, 774, 775, 776, 777, 778, 779, 780, 781, 782, 783, 784, 785, 786, 787, 788, 789, 790, 791, 792, 793, 794, 795, 796, 797, 798, 799, 800, 801, 802, 803, 804, 805, 806, 807, 808, 809, 810, 811, 812, 813, 814, 815, 816, 817, 818, 819, 820, 821, 822, 823, 824, 825, 826, 827, 828, 829, 830, 831, 832, 833, 834, 835, 836, 837, 838, 839, 840, 841, 842, 843, 844, 845, 846, 847, 848, 849, 850, 851, 852, 853, 854, 855, 856, 857, 858, 859, 860, 861, 862, 863, 864, 865, 866, 867, 868, 869, 870, 871, 872, 873, 874, 875, 876, 877, 878, 879, 880, 881, 882, 883, 884, 885, 886, 887, 888, 889, 890, 891, 892, 893, 894, 895, 896, 897, 898, 899, 900, 901, 902, 903, 904, 905, 906, 907, 908, 909, 910, 911, 912, 913, 914, 915, 916, 917, 918, 919, 920, 921, 922, 923, 924, 925, 926, 927, 928, 929, 930, 931, 932, 933, 934, 935, 936, 937, 938, 939, 940, 941, 942, 943, 944, 945, 946, 947, 948, 949, 950, 951, 952, 953, 954, 955, 956, 957, 958, 959, 960, 961, 962, 963, 964, 965, 966, 967, 968, 969, 970, 971, 972, 973, 974, 975, 976, 977, 978, 979, 980, 981, 982, 983, 984, 985, 986, 987, 988, 989, 990, 991, 992, 993, 994, 995, 996, 997, 998, 999, 1000

MAIN CONTRACTOR :
Gammon

STRUCTURAL ENGINEER :
ARUP

FACADE CONSULTANT:
MEINHARDT

NOTE :
 1. ALL DIMENSIONS ARE IN mm.
 2. ALL ELEVATIONS ARE VIEWED FROM OUTSIDE.
 3. ALL DIMENSIONS TO BE VERIFIED ON SITE BEFORE FABRICATION.

LEGEND :
 (x1) --- DETAIL MARK NO.
 (x001) --- REFER SHEET NO.
 1. F.F.L. --- FINISHED FLOOR LEVEL
 2. S.F.L. --- STRUCTURAL FLOOR LEVEL
 3. (R) --- REVERSED DETAIL
 4. ▲ --- FIXING LOCATION
 5. △ --- FIXING LUG LOCATION
 6. GLASS LEGEND
 GL01 --- 8mm+12mm AIR GAP+10mm THK. I.G.U.
 GL01a --- 8mm+9mm AIR GAP+12mm THK. I.G.U.
 GL02 --- 10mm THK. TEMPERED GLASS (SPANDREL GLASS)
 GL03 --- 6mm+12mm AIR GAP+6mm THK. I.G.U.
 GL04 --- 10mm THK. TEMPERED GLASS (PROTECTIVE BARRIER)
 GL05 --- 6mm+12mm AIR GAP+8mm THK. I.G.U.

NO.	DATE	REVISION	BY
A	05/03/2021	REVISION SUBJECT TO ARCH.COMMENT	lvart

JOB NO. : J-852
 PROJECT :
 PROPOSED RESIDENTIAL DEVELOPMENT
 AT 139 - 147 ARGYLE STREET,
 NKIL 6005, 6035 R.P., 6036 R.P.,
 6037 R.P. & 6038 R.P.

TITLE :
 DETAIL FOR
 Plenum Box

DATE : 05-Dec-19 SCALE : 1:2

DRAWN BY : MN CHECKED BY : DW

美特鋁質有限公司
MIDI ALUMINIUM FABRICATOR LTD.
 Units 6-8, Sunray Industrial Centre, 1/F
 610 Cha Kwo Ling Road, Kowloon
 Tel:23489211-4 Fax:(852)2727666

DWG NO. : J852-SD-PB-6001b REV. : A

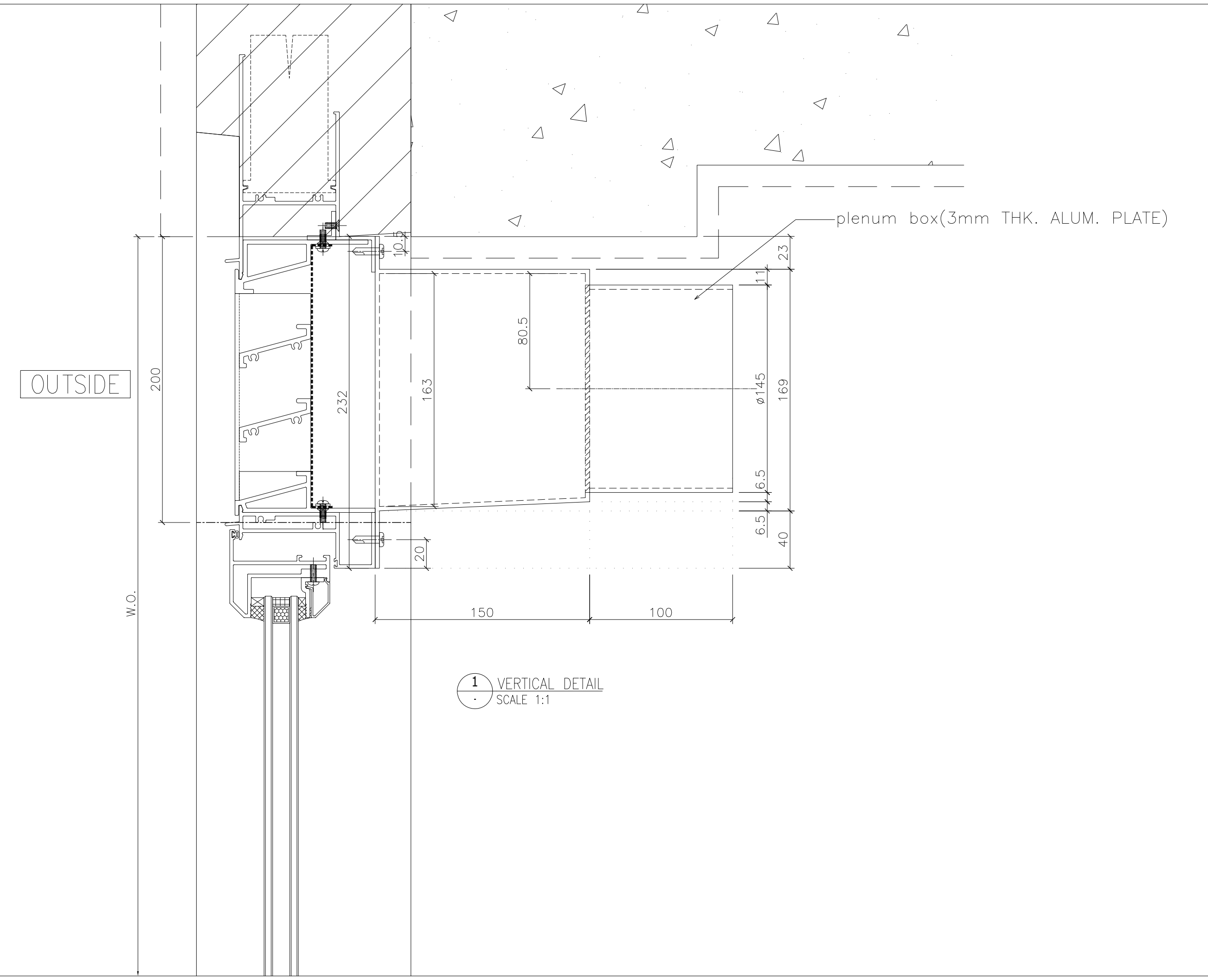

plenum box(3mm THK. ALUM. PLATE)

1 VERTICAL DETAIL
SCALE 1:1

B.D. REF :

CLIENT :

ARCHITECT :
AGC DESIGN LTD
 101, 102, 103, 104, 105, 106, 107, 108, 109, 110, 111, 112, 113, 114, 115, 116, 117, 118, 119, 120, 121, 122, 123, 124, 125, 126, 127, 128, 129, 130, 131, 132, 133, 134, 135, 136, 137, 138, 139, 140, 141, 142, 143, 144, 145, 146, 147, 148, 149, 150, 151, 152, 153, 154, 155, 156, 157, 158, 159, 160, 161, 162, 163, 164, 165, 166, 167, 168, 169, 170, 171, 172, 173, 174, 175, 176, 177, 178, 179, 180, 181, 182, 183, 184, 185, 186, 187, 188, 189, 190, 191, 192, 193, 194, 195, 196, 197, 198, 199, 200, 201, 202, 203, 204, 205, 206, 207, 208, 209, 210, 211, 212, 213, 214, 215, 216, 217, 218, 219, 220, 221, 222, 223, 224, 225, 226, 227, 228, 229, 230, 231, 232, 233, 234, 235, 236, 237, 238, 239, 240, 241, 242, 243, 244, 245, 246, 247, 248, 249, 250, 251, 252, 253, 254, 255, 256, 257, 258, 259, 260, 261, 262, 263, 264, 265, 266, 267, 268, 269, 270, 271, 272, 273, 274, 275, 276, 277, 278, 279, 280, 281, 282, 283, 284, 285, 286, 287, 288, 289, 290, 291, 292, 293, 294, 295, 296, 297, 298, 299, 300, 301, 302, 303, 304, 305, 306, 307, 308, 309, 310, 311, 312, 313, 314, 315, 316, 317, 318, 319, 320, 321, 322, 323, 324, 325, 326, 327, 328, 329, 330, 331, 332, 333, 334, 335, 336, 337, 338, 339, 340, 341, 342, 343, 344, 345, 346, 347, 348, 349, 350, 351, 352, 353, 354, 355, 356, 357, 358, 359, 360, 361, 362, 363, 364, 365, 366, 367, 368, 369, 370, 371, 372, 373, 374, 375, 376, 377, 378, 379, 380, 381, 382, 383, 384, 385, 386, 387, 388, 389, 390, 391, 392, 393, 394, 395, 396, 397, 398, 399, 400, 401, 402, 403, 404, 405, 406, 407, 408, 409, 410, 411, 412, 413, 414, 415, 416, 417, 418, 419, 420, 421, 422, 423, 424, 425, 426, 427, 428, 429, 430, 431, 432, 433, 434, 435, 436, 437, 438, 439, 440, 441, 442, 443, 444, 445, 446, 447, 448, 449, 450, 451, 452, 453, 454, 455, 456, 457, 458, 459, 460, 461, 462, 463, 464, 465, 466, 467, 468, 469, 470, 471, 472, 473, 474, 475, 476, 477, 478, 479, 480, 481, 482, 483, 484, 485, 486, 487, 488, 489, 490, 491, 492, 493, 494, 495, 496, 497, 498, 499, 500, 501, 502, 503, 504, 505, 506, 507, 508, 509, 510, 511, 512, 513, 514, 515, 516, 517, 518, 519, 520, 521, 522, 523, 524, 525, 526, 527, 528, 529, 530, 531, 532, 533, 534, 535, 536, 537, 538, 539, 540, 541, 542, 543, 544, 545, 546, 547, 548, 549, 550, 551, 552, 553, 554, 555, 556, 557, 558, 559, 560, 561, 562, 563, 564, 565, 566, 567, 568, 569, 570, 571, 572, 573, 574, 575, 576, 577, 578, 579, 580, 581, 582, 583, 584, 585, 586, 587, 588, 589, 590, 591, 592, 593, 594, 595, 596, 597, 598, 599, 600, 601, 602, 603, 604, 605, 606, 607, 608, 609, 610, 611, 612, 613, 614, 615, 616, 617, 618, 619, 620, 621, 622, 623, 624, 625, 626, 627, 628, 629, 630, 631, 632, 633, 634, 635, 636, 637, 638, 639, 640, 641, 642, 643, 644, 645, 646, 647, 648, 649, 650, 651, 652, 653, 654, 655, 656, 657, 658, 659, 660, 661, 662, 663, 664, 665, 666, 667, 668, 669, 670, 671, 672, 673, 674, 675, 676, 677, 678, 679, 680, 681, 682, 683, 684, 685, 686, 687, 688, 689, 690, 691, 692, 693, 694, 695, 696, 697, 698, 699, 700, 701, 702, 703, 704, 705, 706, 707, 708, 709, 710, 711, 712, 713, 714, 715, 716, 717, 718, 719, 720, 721, 722, 723, 724, 725, 726, 727, 728, 729, 730, 731, 732, 733, 734, 735, 736, 737, 738, 739, 740, 741, 742, 743, 744, 745, 746, 747, 748, 749, 750, 751, 752, 753, 754, 755, 756, 757, 758, 759, 760, 761, 762, 763, 764, 765, 766, 767, 768, 769, 770, 771, 772, 773, 774, 775, 776, 777, 778, 779, 780, 781, 782, 783, 784, 785, 786, 787, 788, 789, 790, 791, 792, 793, 794, 795, 796, 797, 798, 799, 800, 801, 802, 803, 804, 805, 806, 807, 808, 809, 810, 811, 812, 813, 814, 815, 816, 817, 818, 819, 820, 821, 822, 823, 824, 825, 826, 827, 828, 829, 830, 831, 832, 833, 834, 835, 836, 837, 838, 839, 840, 841, 842, 843, 844, 845, 846, 847, 848, 849, 850, 851, 852, 853, 854, 855, 856, 857, 858, 859, 860, 861, 862, 863, 864, 865, 866, 867, 868, 869, 870, 871, 872, 873, 874, 875, 876, 877, 878, 879, 880, 881, 882, 883, 884, 885, 886, 887, 888, 889, 890, 891, 892, 893, 894, 895, 896, 897, 898, 899, 900, 901, 902, 903, 904, 905, 906, 907, 908, 909, 910, 911, 912, 913, 914, 915, 916, 917, 918, 919, 920, 921, 922, 923, 924, 925, 926, 927, 928, 929, 930, 931, 932, 933, 934, 935, 936, 937, 938, 939, 940, 941, 942, 943, 944, 945, 946, 947, 948, 949, 950, 951, 952, 953, 954, 955, 956, 957, 958, 959, 960, 961, 962, 963, 964, 965, 966, 967, 968, 969, 970, 971, 972, 973, 974, 975, 976, 977, 978, 979, 980, 981, 982, 983, 984, 985, 986, 987, 988, 989, 990, 991, 992, 993, 994, 995, 996, 997, 998, 999, 1000

NOTE :

- ALL DIMENSIONS ARE IN mm.
- ALL ELEVATIONS ARE VIEWED FROM OUTSIDE.
- ALL DIMENSIONS TO BE VERIFIED ON SITE BEFORE FABRICATION.

LEGEND :

x1 — DETAIL MARK NO.
 x001 — REFER SHEET NO.

- F.F.L. -- FINISHED FLOOR LEVEL
- S.F.L. -- STRUCTURAL FLOOR LEVEL
- (R) -- REVERSED DETAIL
- ▲ -- FIXING LOCATION
- △ -- FIXING LUG LOCATION
- GLASS LEGEND
 GL01 -- 8mm+12mm AIR GAP+10mm THK. I.G.U.
 GL01a -- 8mm+9mm AIR GAP+12mm THK. I.G.U.
 GL02 -- 10mm THK. TEMPERED GLASS (SPANDREL GLASS)
 GL03 -- 6mm+12mm AIR GAP+6mm THK. I.G.U.
 GL04 -- 10mm THK. TEMPERED GLASS (PROTECTIVE BARRIER)
 GL05 -- 6mm+12mm AIR GAP+8mm THK. I.G.U.

NO.	DATE	REVISED	BY
JOB NO. : J-852			
PROJECT : PROPOSED RESIDENTIAL DEVELOPMENT AT 139 - 147 ARGYLE STREET, NKIL 6005, 6035 R.P., 6036 R.P., 6037 R.P. & 6038 R.P.			
TITLE : DETAIL FOR Plenum Box			
DATE : 05-Dec-19		SCALE : 1:2	
DRAWN BY : MN		CHECKED BY : DW	
美特鋁質有限公司 MIDI ALUMINIUM FABRICATOR LTD. Units 6-8, Sunray Industrial Centre, 1/F 610 Cha Kwo Ling Road, Kowloon Tel:23489211-4 Fax:(852)2727666			
DWG NO. : J852-SD-PB-6001c			REV. : -

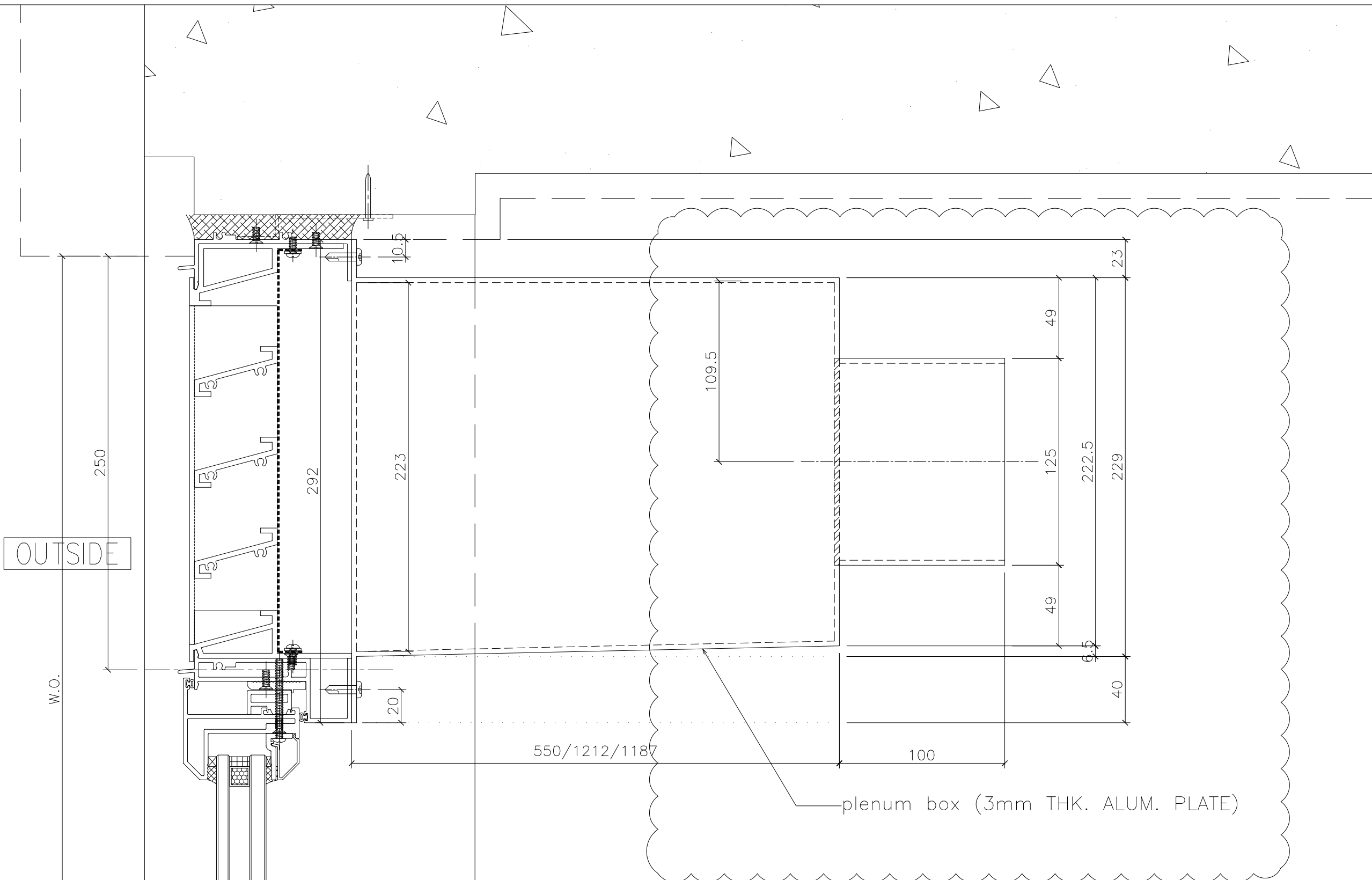

1 VERTICAL DETAIL
SCALE 1:1

B.D. REF :

CLIENT :

ARCHITECT :
AGC DESIGN LTD
 10/F, 107, Spadina Road, 225, Hong Kong
 Tel: (852) 2521 1111, Fax: (852) 2521 1112, Email: agc@agc.com.hk

MAIN CONTRACTOR :
Gammon

STRUCTURAL ENGINEER :
ARUP

FACADE CONSULTANT:
MEINHARDT

NOTE :

1. ALL DIMENSIONS ARE IN mm.
2. ALL ELEVATIONS ARE VIEWED FROM OUTSIDE.
3. ALL DIMENSIONS TO BE VERIFIED ON SITE BEFORE FABRICATION.

LEGEND :

(x1) — DETAIL MARK NO.
 (x001) — REFER SHEET NO.

1. F.F.L. -- FINISHED FLOOR LEVEL
2. S.F.L. -- STRUCTURAL FLOOR LEVEL
3. (R) -- REVERSED DETAIL
4. ▲ -- FIXING LOCATION
5. △ -- FIXING LUG LOCATION
6. GLASS LEGEND
 GL01 -- 8mm+12mm AIR GAP+10mm THK. I.G.U.
 GL01a -- 8mm+9mm AIR GAP+12mm THK. I.G.U.
 GL02 -- 10mm THK. TEMPERED GLASS (SPANDREL GLASS)
 GL03 -- 6mm+12mm AIR GAP+6mm THK. I.G.U.
 GL04 -- 10mm THK. TEMPERED GLASS (PROTECTIVE BARRIER)
 GL05 -- 6mm+12mm AIR GAP+8mm THK. I.G.U.

NO.	DATE	REVISION	BY
A	09/12/2020	REVISION SUBJECT TO ARCH.COMMENT	lvn

JOB NO. : J-852

PROJECT :
 PROPOSED RESIDENTIAL DEVELOPMENT
 AT 139 - 147 ARGYLE STREET,
 NKIL 6005, 6035 R.P., 6036 R.P.,
 6037 R.P. & 6038 R.P.

TITLE :
 DETAIL FOR
 Plenum Box

DATE : 05-Dec-19 SCALE : 1:2

DRAWN BY : MN CHECKED BY : DW

美特鋁質有限公司
MIDI ALUMINIUM FABRICATOR LTD.
 Units 6-8, Sunray Industrial Centre, 1/F
 610 Cha Kwo Ling Road, Kowloon
 Tel:23489211-4 Fax:(852)2727666

DWG NO. : J852-SD-PB-6002 REV. : A

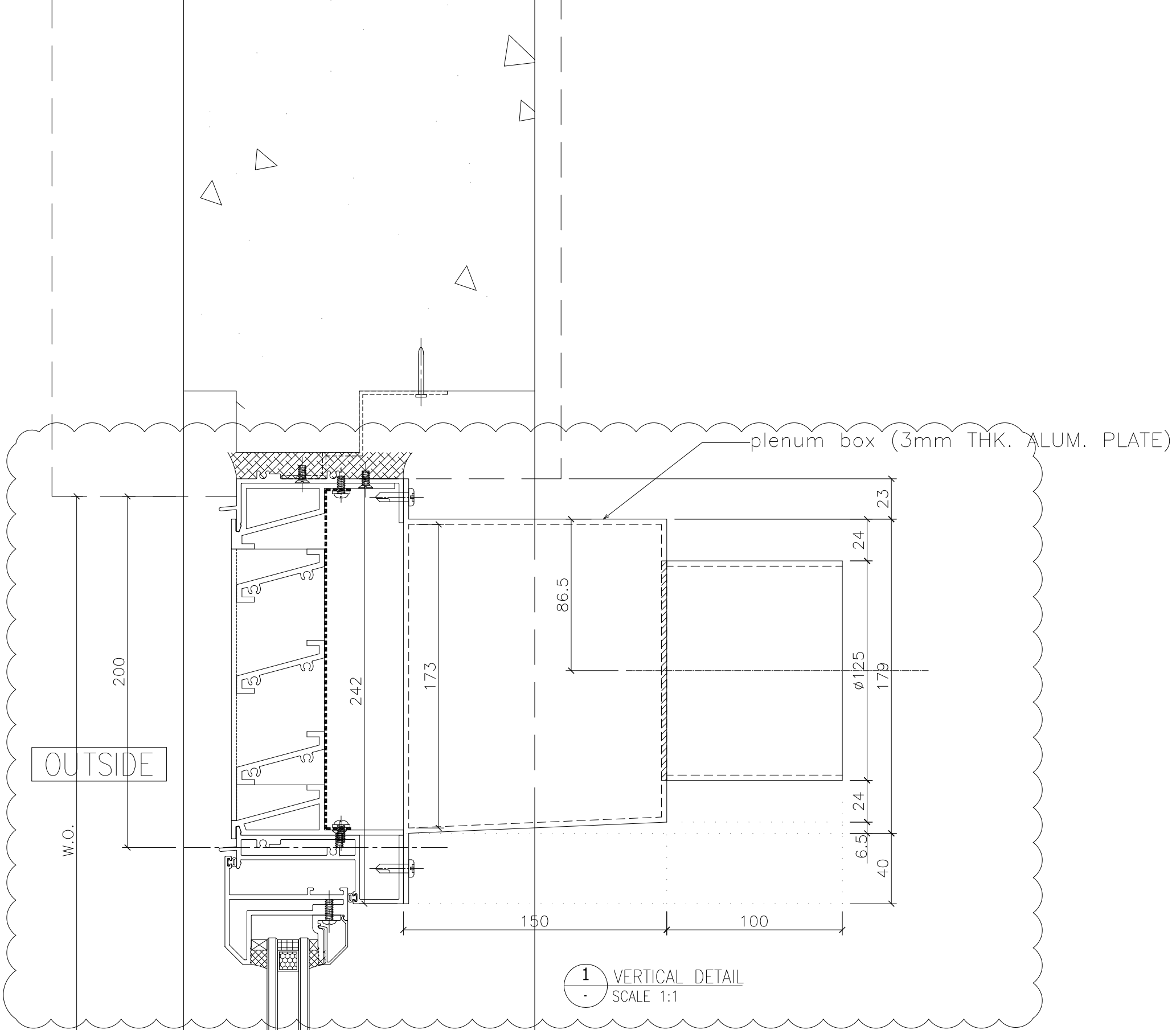

B.D. REF :

CLIENT :

ARCHITECT :
AGC DESIGN LTD
 101, 102, 103, 104, 105, 106, 107, 108, 109, 110, 111, 112, 113, 114, 115, 116, 117, 118, 119, 120, 121, 122, 123, 124, 125, 126, 127, 128, 129, 130, 131, 132, 133, 134, 135, 136, 137, 138, 139, 140, 141, 142, 143, 144, 145, 146, 147, 148, 149, 150, 151, 152, 153, 154, 155, 156, 157, 158, 159, 160, 161, 162, 163, 164, 165, 166, 167, 168, 169, 170, 171, 172, 173, 174, 175, 176, 177, 178, 179, 180, 181, 182, 183, 184, 185, 186, 187, 188, 189, 190, 191, 192, 193, 194, 195, 196, 197, 198, 199, 200, 201, 202, 203, 204, 205, 206, 207, 208, 209, 210, 211, 212, 213, 214, 215, 216, 217, 218, 219, 220, 221, 222, 223, 224, 225, 226, 227, 228, 229, 230, 231, 232, 233, 234, 235, 236, 237, 238, 239, 240, 241, 242, 243, 244, 245, 246, 247, 248, 249, 250, 251, 252, 253, 254, 255, 256, 257, 258, 259, 260, 261, 262, 263, 264, 265, 266, 267, 268, 269, 270, 271, 272, 273, 274, 275, 276, 277, 278, 279, 280, 281, 282, 283, 284, 285, 286, 287, 288, 289, 290, 291, 292, 293, 294, 295, 296, 297, 298, 299, 300, 301, 302, 303, 304, 305, 306, 307, 308, 309, 310, 311, 312, 313, 314, 315, 316, 317, 318, 319, 320, 321, 322, 323, 324, 325, 326, 327, 328, 329, 330, 331, 332, 333, 334, 335, 336, 337, 338, 339, 340, 341, 342, 343, 344, 345, 346, 347, 348, 349, 350, 351, 352, 353, 354, 355, 356, 357, 358, 359, 360, 361, 362, 363, 364, 365, 366, 367, 368, 369, 370, 371, 372, 373, 374, 375, 376, 377, 378, 379, 380, 381, 382, 383, 384, 385, 386, 387, 388, 389, 390, 391, 392, 393, 394, 395, 396, 397, 398, 399, 400, 401, 402, 403, 404, 405, 406, 407, 408, 409, 410, 411, 412, 413, 414, 415, 416, 417, 418, 419, 420, 421, 422, 423, 424, 425, 426, 427, 428, 429, 430, 431, 432, 433, 434, 435, 436, 437, 438, 439, 440, 441, 442, 443, 444, 445, 446, 447, 448, 449, 450, 451, 452, 453, 454, 455, 456, 457, 458, 459, 460, 461, 462, 463, 464, 465, 466, 467, 468, 469, 470, 471, 472, 473, 474, 475, 476, 477, 478, 479, 480, 481, 482, 483, 484, 485, 486, 487, 488, 489, 490, 491, 492, 493, 494, 495, 496, 497, 498, 499, 500, 501, 502, 503, 504, 505, 506, 507, 508, 509, 510, 511, 512, 513, 514, 515, 516, 517, 518, 519, 520, 521, 522, 523, 524, 525, 526, 527, 528, 529, 530, 531, 532, 533, 534, 535, 536, 537, 538, 539, 540, 541, 542, 543, 544, 545, 546, 547, 548, 549, 550, 551, 552, 553, 554, 555, 556, 557, 558, 559, 560, 561, 562, 563, 564, 565, 566, 567, 568, 569, 570, 571, 572, 573, 574, 575, 576, 577, 578, 579, 580, 581, 582, 583, 584, 585, 586, 587, 588, 589, 590, 591, 592, 593, 594, 595, 596, 597, 598, 599, 600, 601, 602, 603, 604, 605, 606, 607, 608, 609, 610, 611, 612, 613, 614, 615, 616, 617, 618, 619, 620, 621, 622, 623, 624, 625, 626, 627, 628, 629, 630, 631, 632, 633, 634, 635, 636, 637, 638, 639, 640, 641, 642, 643, 644, 645, 646, 647, 648, 649, 650, 651, 652, 653, 654, 655, 656, 657, 658, 659, 660, 661, 662, 663, 664, 665, 666, 667, 668, 669, 670, 671, 672, 673, 674, 675, 676, 677, 678, 679, 680, 681, 682, 683, 684, 685, 686, 687, 688, 689, 690, 691, 692, 693, 694, 695, 696, 697, 698, 699, 700, 701, 702, 703, 704, 705, 706, 707, 708, 709, 710, 711, 712, 713, 714, 715, 716, 717, 718, 719, 720, 721, 722, 723, 724, 725, 726, 727, 728, 729, 730, 731, 732, 733, 734, 735, 736, 737, 738, 739, 740, 741, 742, 743, 744, 745, 746, 747, 748, 749, 750, 751, 752, 753, 754, 755, 756, 757, 758, 759, 760, 761, 762, 763, 764, 765, 766, 767, 768, 769, 770, 771, 772, 773, 774, 775, 776, 777, 778, 779, 780, 781, 782, 783, 784, 785, 786, 787, 788, 789, 790, 791, 792, 793, 794, 795, 796, 797, 798, 799, 800, 801, 802, 803, 804, 805, 806, 807, 808, 809, 810, 811, 812, 813, 814, 815, 816, 817, 818, 819, 820, 821, 822, 823, 824, 825, 826, 827, 828, 829, 830, 831, 832, 833, 834, 835, 836, 837, 838, 839, 840, 841, 842, 843, 844, 845, 846, 847, 848, 849, 850, 851, 852, 853, 854, 855, 856, 857, 858, 859, 860, 861, 862, 863, 864, 865, 866, 867, 868, 869, 870, 871, 872, 873, 874, 875, 876, 877, 878, 879, 880, 881, 882, 883, 884, 885, 886, 887, 888, 889, 890, 891, 892, 893, 894, 895, 896, 897, 898, 899, 900, 901, 902, 903, 904, 905, 906, 907, 908, 909, 910, 911, 912, 913, 914, 915, 916, 917, 918, 919, 920, 921, 922, 923, 924, 925, 926, 927, 928, 929, 930, 931, 932, 933, 934, 935, 936, 937, 938, 939, 940, 941, 942, 943, 944, 945, 946, 947, 948, 949, 950, 951, 952, 953, 954, 955, 956, 957, 958, 959, 960, 961, 962, 963, 964, 965, 966, 967, 968, 969, 970, 971, 972, 973, 974, 975, 976, 977, 978, 979, 980, 981, 982, 983, 984, 985, 986, 987, 988, 989, 990, 991, 992, 993, 994, 995, 996, 997, 998, 999, 1000

MAIN CONTRACTOR :
Gammon

STRUCTURAL ENGINEER :
ARUP

FACADE CONSULTANT:
MEINHARDT

NOTE :
 1. ALL DIMENSIONS ARE IN mm.
 2. ALL ELEVATIONS ARE VIEWED FROM OUTSIDE.
 3. ALL DIMENSIONS TO BE VERIFIED ON SITE BEFORE FABRICATION.

LEGEND :
 (X1) — DETAIL MARK NO.
 (X001) — REFER SHEET NO.
 1. F.F.L. -- FINISHED FLOOR LEVEL
 2. S.F.L. -- STRUCTURAL FLOOR LEVEL
 3. (R) -- REVERSED DETAIL

NO.	DATE	REVISION	BY
A	09/12/2020	REVISION SUBJECT TO ARCH.COMMENT	Ivan

JOB NO. : J-852
 PROJECT : PROPOSED RESIDENTIAL DEVELOPMENT AT 139 - 147 ARGYLE STREET, NKIL 6005, 6035 R.P., 6036 R.P., 6037 R.P. & 6038 R.P.

TITLE :
 DETAIL FOR Plenum Box

DATE : 05-Dec-19 SCALE : 1:2
 DRAWN BY : MN CHECKED BY : DW

美特鋁質有限公司
MIDI ALUMINIUM FABRICATOR LTD.
 Units 6-8, Sunray Industrial Centre, 1/F
 610 Cha Kwo Ling Road, Kowloon
 Tel:23489211-4 Fax:(852)2727666

DWG NO. : J852-SD-PB-6003 REV. : A

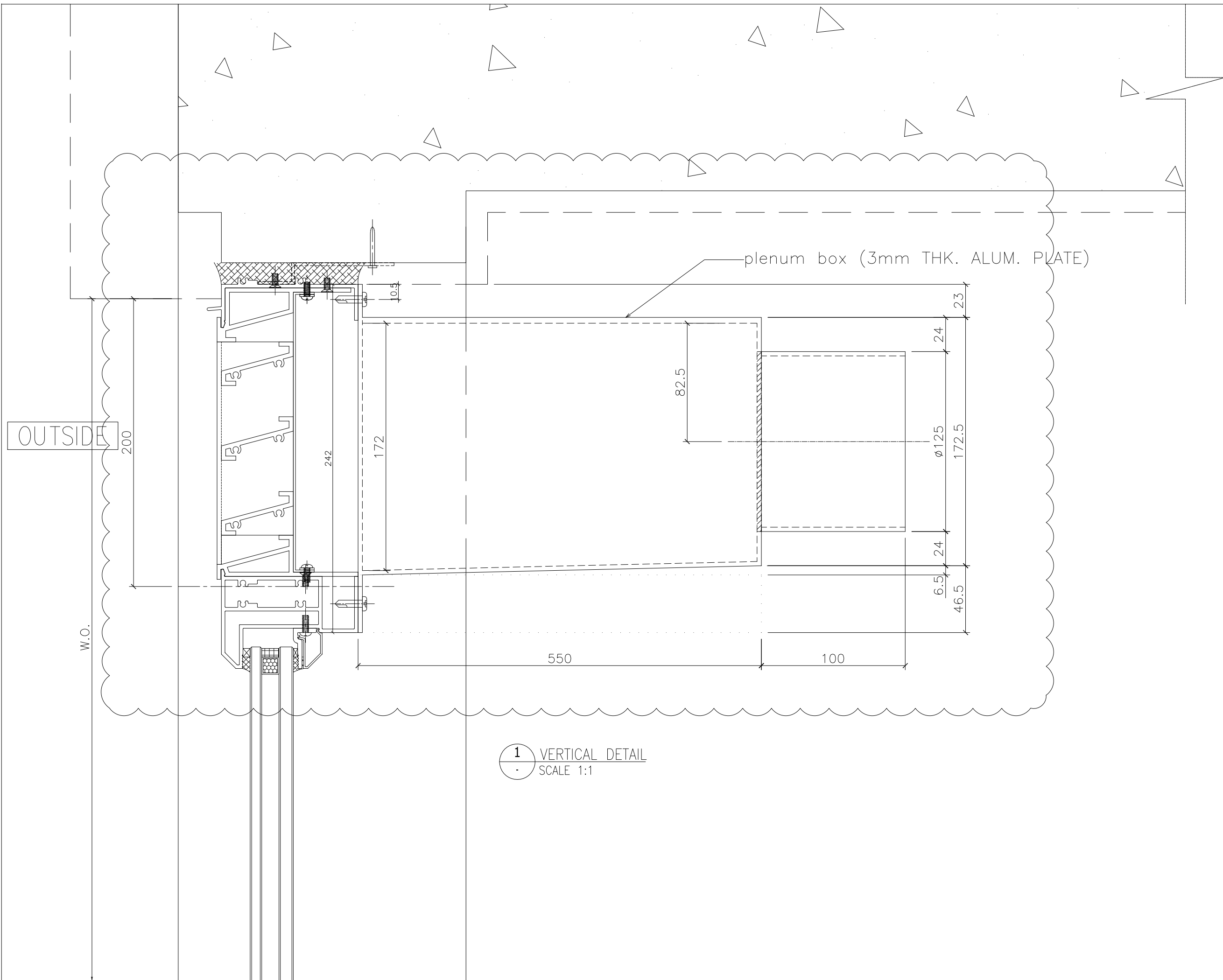

B.D. REF :

CLIENT :

ARCHITECT :
AGC
 DESIGN LTD
 181, 182, 183, 184, 185, 186, 187, 188, 189, 190, 191, 192, 193, 194, 195, 196, 197, 198, 199, 200, 201, 202, 203, 204, 205, 206, 207, 208, 209, 210, 211, 212, 213, 214, 215, 216, 217, 218, 219, 220, 221, 222, 223, 224, 225, 226, 227, 228, 229, 230, 231, 232, 233, 234, 235, 236, 237, 238, 239, 240, 241, 242, 243, 244, 245, 246, 247, 248, 249, 250, 251, 252, 253, 254, 255, 256, 257, 258, 259, 260, 261, 262, 263, 264, 265, 266, 267, 268, 269, 270, 271, 272, 273, 274, 275, 276, 277, 278, 279, 280, 281, 282, 283, 284, 285, 286, 287, 288, 289, 290, 291, 292, 293, 294, 295, 296, 297, 298, 299, 300, 301, 302, 303, 304, 305, 306, 307, 308, 309, 310, 311, 312, 313, 314, 315, 316, 317, 318, 319, 320, 321, 322, 323, 324, 325, 326, 327, 328, 329, 330, 331, 332, 333, 334, 335, 336, 337, 338, 339, 340, 341, 342, 343, 344, 345, 346, 347, 348, 349, 350, 351, 352, 353, 354, 355, 356, 357, 358, 359, 360, 361, 362, 363, 364, 365, 366, 367, 368, 369, 370, 371, 372, 373, 374, 375, 376, 377, 378, 379, 380, 381, 382, 383, 384, 385, 386, 387, 388, 389, 390, 391, 392, 393, 394, 395, 396, 397, 398, 399, 400, 401, 402, 403, 404, 405, 406, 407, 408, 409, 410, 411, 412, 413, 414, 415, 416, 417, 418, 419, 420, 421, 422, 423, 424, 425, 426, 427, 428, 429, 430, 431, 432, 433, 434, 435, 436, 437, 438, 439, 440, 441, 442, 443, 444, 445, 446, 447, 448, 449, 450, 451, 452, 453, 454, 455, 456, 457, 458, 459, 460, 461, 462, 463, 464, 465, 466, 467, 468, 469, 470, 471, 472, 473, 474, 475, 476, 477, 478, 479, 480, 481, 482, 483, 484, 485, 486, 487, 488, 489, 490, 491, 492, 493, 494, 495, 496, 497, 498, 499, 500, 501, 502, 503, 504, 505, 506, 507, 508, 509, 510, 511, 512, 513, 514, 515, 516, 517, 518, 519, 520, 521, 522, 523, 524, 525, 526, 527, 528, 529, 530, 531, 532, 533, 534, 535, 536, 537, 538, 539, 540, 541, 542, 543, 544, 545, 546, 547, 548, 549, 550, 551, 552, 553, 554, 555, 556, 557, 558, 559, 560, 561, 562, 563, 564, 565, 566, 567, 568, 569, 570, 571, 572, 573, 574, 575, 576, 577, 578, 579, 580, 581, 582, 583, 584, 585, 586, 587, 588, 589, 590, 591, 592, 593, 594, 595, 596, 597, 598, 599, 600, 601, 602, 603, 604, 605, 606, 607, 608, 609, 610, 611, 612, 613, 614, 615, 616, 617, 618, 619, 620, 621, 622, 623, 624, 625, 626, 627, 628, 629, 630, 631, 632, 633, 634, 635, 636, 637, 638, 639, 640, 641, 642, 643, 644, 645, 646, 647, 648, 649, 650, 651, 652, 653, 654, 655, 656, 657, 658, 659, 660, 661, 662, 663, 664, 665, 666, 667, 668, 669, 670, 671, 672, 673, 674, 675, 676, 677, 678, 679, 680, 681, 682, 683, 684, 685, 686, 687, 688, 689, 690, 691, 692, 693, 694, 695, 696, 697, 698, 699, 700, 701, 702, 703, 704, 705, 706, 707, 708, 709, 710, 711, 712, 713, 714, 715, 716, 717, 718, 719, 720, 721, 722, 723, 724, 725, 726, 727, 728, 729, 730, 731, 732, 733, 734, 735, 736, 737, 738, 739, 740, 741, 742, 743, 744, 745, 746, 747, 748, 749, 750, 751, 752, 753, 754, 755, 756, 757, 758, 759, 760, 761, 762, 763, 764, 765, 766, 767, 768, 769, 770, 771, 772, 773, 774, 775, 776, 777, 778, 779, 780, 781, 782, 783, 784, 785, 786, 787, 788, 789, 790, 791, 792, 793, 794, 795, 796, 797, 798, 799, 800, 801, 802, 803, 804, 805, 806, 807, 808, 809, 810, 811, 812, 813, 814, 815, 816, 817, 818, 819, 820, 821, 822, 823, 824, 825, 826, 827, 828, 829, 830, 831, 832, 833, 834, 835, 836, 837, 838, 839, 840, 841, 842, 843, 844, 845, 846, 847, 848, 849, 850, 851, 852, 853, 854, 855, 856, 857, 858, 859, 860, 861, 862, 863, 864, 865, 866, 867, 868, 869, 870, 871, 872, 873, 874, 875, 876, 877, 878, 879, 880, 881, 882, 883, 884, 885, 886, 887, 888, 889, 890, 891, 892, 893, 894, 895, 896, 897, 898, 899, 900, 901, 902, 903, 904, 905, 906, 907, 908, 909, 910, 911, 912, 913, 914, 915, 916, 917, 918, 919, 920, 921, 922, 923, 924, 925, 926, 927, 928, 929, 930, 931, 932, 933, 934, 935, 936, 937, 938, 939, 940, 941, 942, 943, 944, 945, 946, 947, 948, 949, 950, 951, 952, 953, 954, 955, 956, 957, 958, 959, 960, 961, 962, 963, 964, 965, 966, 967, 968, 969, 970, 971, 972, 973, 974, 975, 976, 977, 978, 979, 980, 981, 982, 983, 984, 985, 986, 987, 988, 989, 990, 991, 992, 993, 994, 995, 996, 997, 998, 999, 1000

MAIN CONTRACTOR :
Gammon

STRUCTURAL ENGINEER :
ARUP

FACADE CONSULTANT:
MEINHARDT

NOTE :
 1. ALL DIMENSIONS ARE IN mm.
 2. ALL ELEVATIONS ARE VIEWED FROM OUTSIDE.
 3. ALL DIMENSIONS TO BE VERIFIED ON SITE BEFORE FABRICATION.

LEGEND :
 (x1) --- DETAIL MARK NO.
 (x001) --- REFER SHEET NO.
 1. F.F.L. --- FINISHED FLOOR LEVEL
 2. S.F.L. --- STRUCTURAL FLOOR LEVEL
 3. (R) --- REVERSED DETAIL

NO.	DATE	REVISION	BY
A	09/12/2020	REVISION SUBJECT TO ARCH.COMMENT	lvart

JOB NO. : J-852
 PROJECT :
 PROPOSED RESIDENTIAL DEVELOPMENT
 AT 139 - 147 ARGYLE STREET,
 NKIL 6005, 6035 R.P., 6036 R.P.,
 6037 R.P. & 6038 R.P.

TITLE :
 DETAIL FOR
 Plenum Box

DATE : 05-Dec-19 SCALE : 1:2
 DRAWN BY : MN CHECKED BY : DW

美特鋁質有限公司
MIDI ALUMINIUM FABRICATOR LTD.
 Units 6-8, Sunray Industrial Centre, 1/F
 610 Cha Kwo Ling Road, Kowloon
 Tel:23489211-4 Fax:(852)2727666
 DWG NO. : J852-SD-PB-6004 REV. : A

OUTSIDE

W.O.

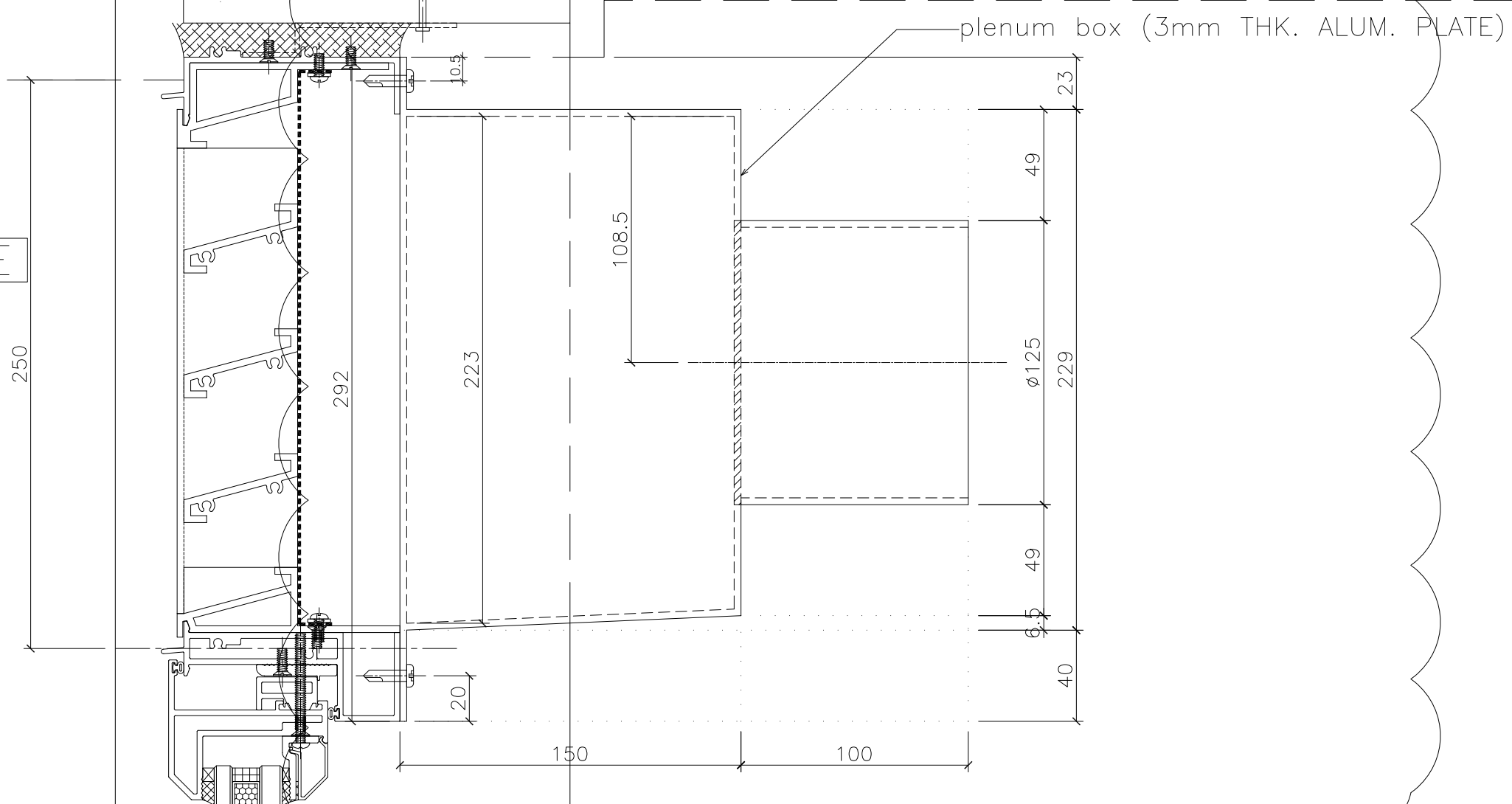

1 VERTICAL DETAIL
SCALE 1:1

B.D. REF :

CLIENT :

ARCHITECT :
AGC
 DESIGN LTD
 100, 101, 102, 103, 104, 105, 106, 107, 108, 109, 110, 111, 112, 113, 114, 115, 116, 117, 118, 119, 120, 121, 122, 123, 124, 125, 126, 127, 128, 129, 130, 131, 132, 133, 134, 135, 136, 137, 138, 139, 140, 141, 142, 143, 144, 145, 146, 147, 148, 149, 150, 151, 152, 153, 154, 155, 156, 157, 158, 159, 160, 161, 162, 163, 164, 165, 166, 167, 168, 169, 170, 171, 172, 173, 174, 175, 176, 177, 178, 179, 180, 181, 182, 183, 184, 185, 186, 187, 188, 189, 190, 191, 192, 193, 194, 195, 196, 197, 198, 199, 200, 201, 202, 203, 204, 205, 206, 207, 208, 209, 210, 211, 212, 213, 214, 215, 216, 217, 218, 219, 220, 221, 222, 223, 224, 225, 226, 227, 228, 229, 230, 231, 232, 233, 234, 235, 236, 237, 238, 239, 240, 241, 242, 243, 244, 245, 246, 247, 248, 249, 250, 251, 252, 253, 254, 255, 256, 257, 258, 259, 260, 261, 262, 263, 264, 265, 266, 267, 268, 269, 270, 271, 272, 273, 274, 275, 276, 277, 278, 279, 280, 281, 282, 283, 284, 285, 286, 287, 288, 289, 290, 291, 292, 293, 294, 295, 296, 297, 298, 299, 300, 301, 302, 303, 304, 305, 306, 307, 308, 309, 310, 311, 312, 313, 314, 315, 316, 317, 318, 319, 320, 321, 322, 323, 324, 325, 326, 327, 328, 329, 330, 331, 332, 333, 334, 335, 336, 337, 338, 339, 340, 341, 342, 343, 344, 345, 346, 347, 348, 349, 350, 351, 352, 353, 354, 355, 356, 357, 358, 359, 360, 361, 362, 363, 364, 365, 366, 367, 368, 369, 370, 371, 372, 373, 374, 375, 376, 377, 378, 379, 380, 381, 382, 383, 384, 385, 386, 387, 388, 389, 390, 391, 392, 393, 394, 395, 396, 397, 398, 399, 400, 401, 402, 403, 404, 405, 406, 407, 408, 409, 410, 411, 412, 413, 414, 415, 416, 417, 418, 419, 420, 421, 422, 423, 424, 425, 426, 427, 428, 429, 430, 431, 432, 433, 434, 435, 436, 437, 438, 439, 440, 441, 442, 443, 444, 445, 446, 447, 448, 449, 450, 451, 452, 453, 454, 455, 456, 457, 458, 459, 460, 461, 462, 463, 464, 465, 466, 467, 468, 469, 470, 471, 472, 473, 474, 475, 476, 477, 478, 479, 480, 481, 482, 483, 484, 485, 486, 487, 488, 489, 490, 491, 492, 493, 494, 495, 496, 497, 498, 499, 500, 501, 502, 503, 504, 505, 506, 507, 508, 509, 510, 511, 512, 513, 514, 515, 516, 517, 518, 519, 520, 521, 522, 523, 524, 525, 526, 527, 528, 529, 530, 531, 532, 533, 534, 535, 536, 537, 538, 539, 540, 541, 542, 543, 544, 545, 546, 547, 548, 549, 550, 551, 552, 553, 554, 555, 556, 557, 558, 559, 560, 561, 562, 563, 564, 565, 566, 567, 568, 569, 570, 571, 572, 573, 574, 575, 576, 577, 578, 579, 580, 581, 582, 583, 584, 585, 586, 587, 588, 589, 590, 591, 592, 593, 594, 595, 596, 597, 598, 599, 600, 601, 602, 603, 604, 605, 606, 607, 608, 609, 610, 611, 612, 613, 614, 615, 616, 617, 618, 619, 620, 621, 622, 623, 624, 625, 626, 627, 628, 629, 630, 631, 632, 633, 634, 635, 636, 637, 638, 639, 640, 641, 642, 643, 644, 645, 646, 647, 648, 649, 650, 651, 652, 653, 654, 655, 656, 657, 658, 659, 660, 661, 662, 663, 664, 665, 666, 667, 668, 669, 670, 671, 672, 673, 674, 675, 676, 677, 678, 679, 680, 681, 682, 683, 684, 685, 686, 687, 688, 689, 690, 691, 692, 693, 694, 695, 696, 697, 698, 699, 700, 701, 702, 703, 704, 705, 706, 707, 708, 709, 710, 711, 712, 713, 714, 715, 716, 717, 718, 719, 720, 721, 722, 723, 724, 725, 726, 727, 728, 729, 730, 731, 732, 733, 734, 735, 736, 737, 738, 739, 740, 741, 742, 743, 744, 745, 746, 747, 748, 749, 750, 751, 752, 753, 754, 755, 756, 757, 758, 759, 760, 761, 762, 763, 764, 765, 766, 767, 768, 769, 770, 771, 772, 773, 774, 775, 776, 777, 778, 779, 780, 781, 782, 783, 784, 785, 786, 787, 788, 789, 790, 791, 792, 793, 794, 795, 796, 797, 798, 799, 800, 801, 802, 803, 804, 805, 806, 807, 808, 809, 810, 811, 812, 813, 814, 815, 816, 817, 818, 819, 820, 821, 822, 823, 824, 825, 826, 827, 828, 829, 830, 831, 832, 833, 834, 835, 836, 837, 838, 839, 840, 841, 842, 843, 844, 845, 846, 847, 848, 849, 850, 851, 852, 853, 854, 855, 856, 857, 858, 859, 860, 861, 862, 863, 864, 865, 866, 867, 868, 869, 870, 871, 872, 873, 874, 875, 876, 877, 878, 879, 880, 881, 882, 883, 884, 885, 886, 887, 888, 889, 890, 891, 892, 893, 894, 895, 896, 897, 898, 899, 900, 901, 902, 903, 904, 905, 906, 907, 908, 909, 910, 911, 912, 913, 914, 915, 916, 917, 918, 919, 920, 921, 922, 923, 924, 925, 926, 927, 928, 929, 930, 931, 932, 933, 934, 935, 936, 937, 938, 939, 940, 941, 942, 943, 944, 945, 946, 947, 948, 949, 950, 951, 952, 953, 954, 955, 956, 957, 958, 959, 960, 961, 962, 963, 964, 965, 966, 967, 968, 969, 970, 971, 972, 973, 974, 975, 976, 977, 978, 979, 980, 981, 982, 983, 984, 985, 986, 987, 988, 989, 990, 991, 992, 993, 994, 995, 996, 997, 998, 999, 1000

MAIN CONTRACTOR :
Gammon

STRUCTURAL ENGINEER :
ARUP

FACADE CONSULTANT:
MEINHARDT

NOTE :
 1. ALL DIMENSIONS ARE IN mm.
 2. ALL ELEVATIONS ARE VIEWED FROM OUTSIDE.
 3. ALL DIMENSIONS TO BE VERIFIED ON SITE BEFORE FABRICATION.

LEGEND :
 (x1) --- DETAIL MARK NO.
 (x001) --- REFER SHEET NO.
 1. F.F.L. --- FINISHED FLOOR LEVEL
 2. S.F.L. --- STRUCTURAL FLOOR LEVEL
 3. (R) --- REVERSED DETAIL

NO.	DATE	REVISION	BY
A	09/12/2020	REVISION SUBJECT TO ARCH.COMMENT	lvart

JOB NO. : J-852
 PROJECT :
 PROPOSED RESIDENTIAL DEVELOPMENT
 AT 139 - 147 ARGYLE STREET,
 NKIL 6005, 6035 R.P., 6036 R.P.,
 6037 R.P. & 6038 R.P.

TITLE :
 DETAIL FOR
 Plenum Box

DATE : 05-Dec-19 SCALE : 1:2

DRAWN BY : MN CHECKED BY : DW

美特鋁質有限公司
MIDI ALUMINIUM FABRICATOR LTD.
 Units 6-8, Sunray Industrial Centre, 1/F
 610 Cha Kwo Ling Road, Kowloon
 Tel:23489211-4 Fax:(852)2727666

DWG NO. : J852-SD-PB-6005 REV. : A

OUTSIDE

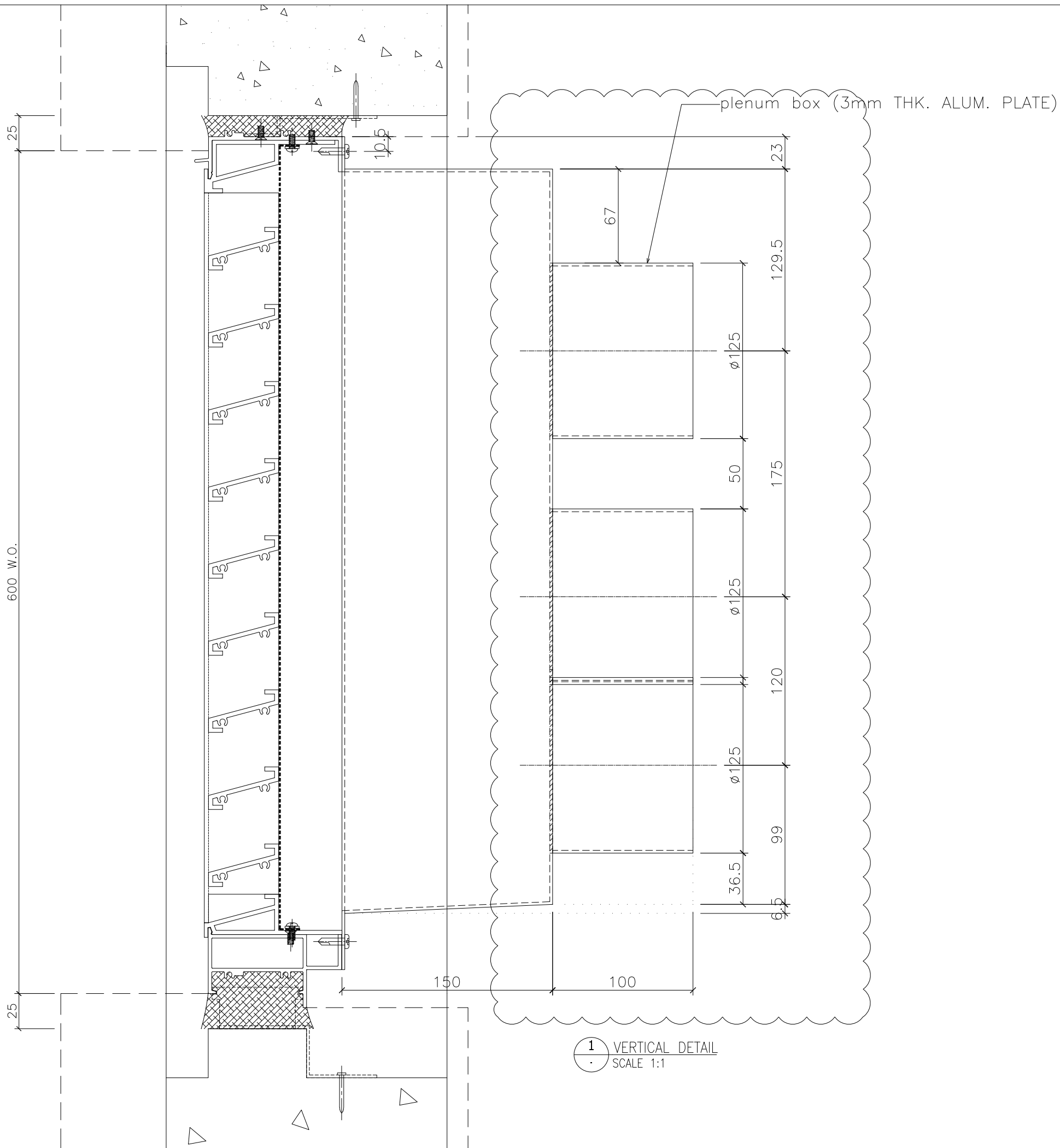

1 VERTICAL DETAIL
SCALE 1:1

B.D. REF :

CLIENT :

ARCHITECT :
AGC DESIGN LTD
AGC DESIGN LTD
101, 102, 103, 104, 105, 106, 107, 108, 109, 110, 111, 112, 113, 114, 115, 116, 117, 118, 119, 120, 121, 122, 123, 124, 125, 126, 127, 128, 129, 130, 131, 132, 133, 134, 135, 136, 137, 138, 139, 140, 141, 142, 143, 144, 145, 146, 147, 148, 149, 150, 151, 152, 153, 154, 155, 156, 157, 158, 159, 160, 161, 162, 163, 164, 165, 166, 167, 168, 169, 170, 171, 172, 173, 174, 175, 176, 177, 178, 179, 180, 181, 182, 183, 184, 185, 186, 187, 188, 189, 190, 191, 192, 193, 194, 195, 196, 197, 198, 199, 200, 201, 202, 203, 204, 205, 206, 207, 208, 209, 210, 211, 212, 213, 214, 215, 216, 217, 218, 219, 220, 221, 222, 223, 224, 225, 226, 227, 228, 229, 230, 231, 232, 233, 234, 235, 236, 237, 238, 239, 240, 241, 242, 243, 244, 245, 246, 247, 248, 249, 250, 251, 252, 253, 254, 255, 256, 257, 258, 259, 260, 261, 262, 263, 264, 265, 266, 267, 268, 269, 270, 271, 272, 273, 274, 275, 276, 277, 278, 279, 280, 281, 282, 283, 284, 285, 286, 287, 288, 289, 290, 291, 292, 293, 294, 295, 296, 297, 298, 299, 300, 301, 302, 303, 304, 305, 306, 307, 308, 309, 310, 311, 312, 313, 314, 315, 316, 317, 318, 319, 320, 321, 322, 323, 324, 325, 326, 327, 328, 329, 330, 331, 332, 333, 334, 335, 336, 337, 338, 339, 340, 341, 342, 343, 344, 345, 346, 347, 348, 349, 350, 351, 352, 353, 354, 355, 356, 357, 358, 359, 360, 361, 362, 363, 364, 365, 366, 367, 368, 369, 370, 371, 372, 373, 374, 375, 376, 377, 378, 379, 380, 381, 382, 383, 384, 385, 386, 387, 388, 389, 390, 391, 392, 393, 394, 395, 396, 397, 398, 399, 400, 401, 402, 403, 404, 405, 406, 407, 408, 409, 410, 411, 412, 413, 414, 415, 416, 417, 418, 419, 420, 421, 422, 423, 424, 425, 426, 427, 428, 429, 430, 431, 432, 433, 434, 435, 436, 437, 438, 439, 440, 441, 442, 443, 444, 445, 446, 447, 448, 449, 450, 451, 452, 453, 454, 455, 456, 457, 458, 459, 460, 461, 462, 463, 464, 465, 466, 467, 468, 469, 470, 471, 472, 473, 474, 475, 476, 477, 478, 479, 480, 481, 482, 483, 484, 485, 486, 487, 488, 489, 490, 491, 492, 493, 494, 495, 496, 497, 498, 499, 500, 501, 502, 503, 504, 505, 506, 507, 508, 509, 510, 511, 512, 513, 514, 515, 516, 517, 518, 519, 520, 521, 522, 523, 524, 525, 526, 527, 528, 529, 530, 531, 532, 533, 534, 535, 536, 537, 538, 539, 540, 541, 542, 543, 544, 545, 546, 547, 548, 549, 550, 551, 552, 553, 554, 555, 556, 557, 558, 559, 560, 561, 562, 563, 564, 565, 566, 567, 568, 569, 570, 571, 572, 573, 574, 575, 576, 577, 578, 579, 580, 581, 582, 583, 584, 585, 586, 587, 588, 589, 590, 591, 592, 593, 594, 595, 596, 597, 598, 599, 600, 601, 602, 603, 604, 605, 606, 607, 608, 609, 610, 611, 612, 613, 614, 615, 616, 617, 618, 619, 620, 621, 622, 623, 624, 625, 626, 627, 628, 629, 630, 631, 632, 633, 634, 635, 636, 637, 638, 639, 640, 641, 642, 643, 644, 645, 646, 647, 648, 649, 650, 651, 652, 653, 654, 655, 656, 657, 658, 659, 660, 661, 662, 663, 664, 665, 666, 667, 668, 669, 670, 671, 672, 673, 674, 675, 676, 677, 678, 679, 680, 681, 682, 683, 684, 685, 686, 687, 688, 689, 690, 691, 692, 693, 694, 695, 696, 697, 698, 699, 700, 701, 702, 703, 704, 705, 706, 707, 708, 709, 710, 711, 712, 713, 714, 715, 716, 717, 718, 719, 720, 721, 722, 723, 724, 725, 726, 727, 728, 729, 730, 731, 732, 733, 734, 735, 736, 737, 738, 739, 740, 741, 742, 743, 744, 745, 746, 747, 748, 749, 750, 751, 752, 753, 754, 755, 756, 757, 758, 759, 760, 761, 762, 763, 764, 765, 766, 767, 768, 769, 770, 771, 772, 773, 774, 775, 776, 777, 778, 779, 780, 781, 782, 783, 784, 785, 786, 787, 788, 789, 790, 791, 792, 793, 794, 795, 796, 797, 798, 799, 800, 801, 802, 803, 804, 805, 806, 807, 808, 809, 810, 811, 812, 813, 814, 815, 816, 817, 818, 819, 820, 821, 822, 823, 824, 825, 826, 827, 828, 829, 830, 831, 832, 833, 834, 835, 836, 837, 838, 839, 840, 841, 842, 843, 844, 845, 846, 847, 848, 849, 850, 851, 852, 853, 854, 855, 856, 857, 858, 859, 860, 861, 862, 863, 864, 865, 866, 867, 868, 869, 870, 871, 872, 873, 874, 875, 876, 877, 878, 879, 880, 881, 882, 883, 884, 885, 886, 887, 888, 889, 890, 891, 892, 893, 894, 895, 896, 897, 898, 899, 900, 901, 902, 903, 904, 905, 906, 907, 908, 909, 910, 911, 912, 913, 914, 915, 916, 917, 918, 919, 920, 921, 922, 923, 924, 925, 926, 927, 928, 929, 930, 931, 932, 933, 934, 935, 936, 937, 938, 939, 940, 941, 942, 943, 944, 945, 946, 947, 948, 949, 950, 951, 952, 953, 954, 955, 956, 957, 958, 959, 960, 961, 962, 963, 964, 965, 966, 967, 968, 969, 970, 971, 972, 973, 974, 975, 976, 977, 978, 979, 980, 981, 982, 983, 984, 985, 986, 987, 988, 989, 990, 991, 992, 993, 994, 995, 996, 997, 998, 999, 1000

MAIN CONTRACTOR :
Gammon

STRUCTURAL ENGINEER :
ARUP

FACADE CONSULTANT:
MEINHARDT

NOTE :
1. ALL DIMENSIONS ARE IN mm.
2. ALL ELEVATIONS ARE VIEWED FROM OUTSIDE.
3. ALL DIMENSIONS TO BE VERIFIED ON SITE BEFORE FABRICATION.

LEGEND :
x1 — DETAIL MARK NO.
x001 — REFER SHEET NO.
1. F.F.L. -- FINISHED FLOOR LEVEL
2. S.F.L. -- STRUCTURAL FLOOR LEVEL
3. (R) -- REVERSED DETAIL

NO.	DATE	REVISION	BY
A	06/01/2021	REVISION SUBJECT TO ARCH.COMMENT	lvart

JOB NO. : J-852
PROJECT : PROPOSED RESIDENTIAL DEVELOPMENT AT 139 - 147 ARGYLE STREET, NKIL 6005, 6035 R.P., 6036 R.P., 6037 R.P. & 6038 R.P.

TITLE : DETAIL FOR Plenum Box

DATE : 05-Dec-19 SCALE : 1:2

DRAWN BY : MN CHECKED BY : DW

美特鋁質有限公司
MIDI ALUMINIUM FABRICATOR LTD.
Units 6-8, Sunray Industrial Centre, 1/F
610 Cha Kwo Ling Road, Kowloon
Tel:23489211-4 Fax:(852)2727666

DWG NO. : J852-SD-PB-6006 REV. : A

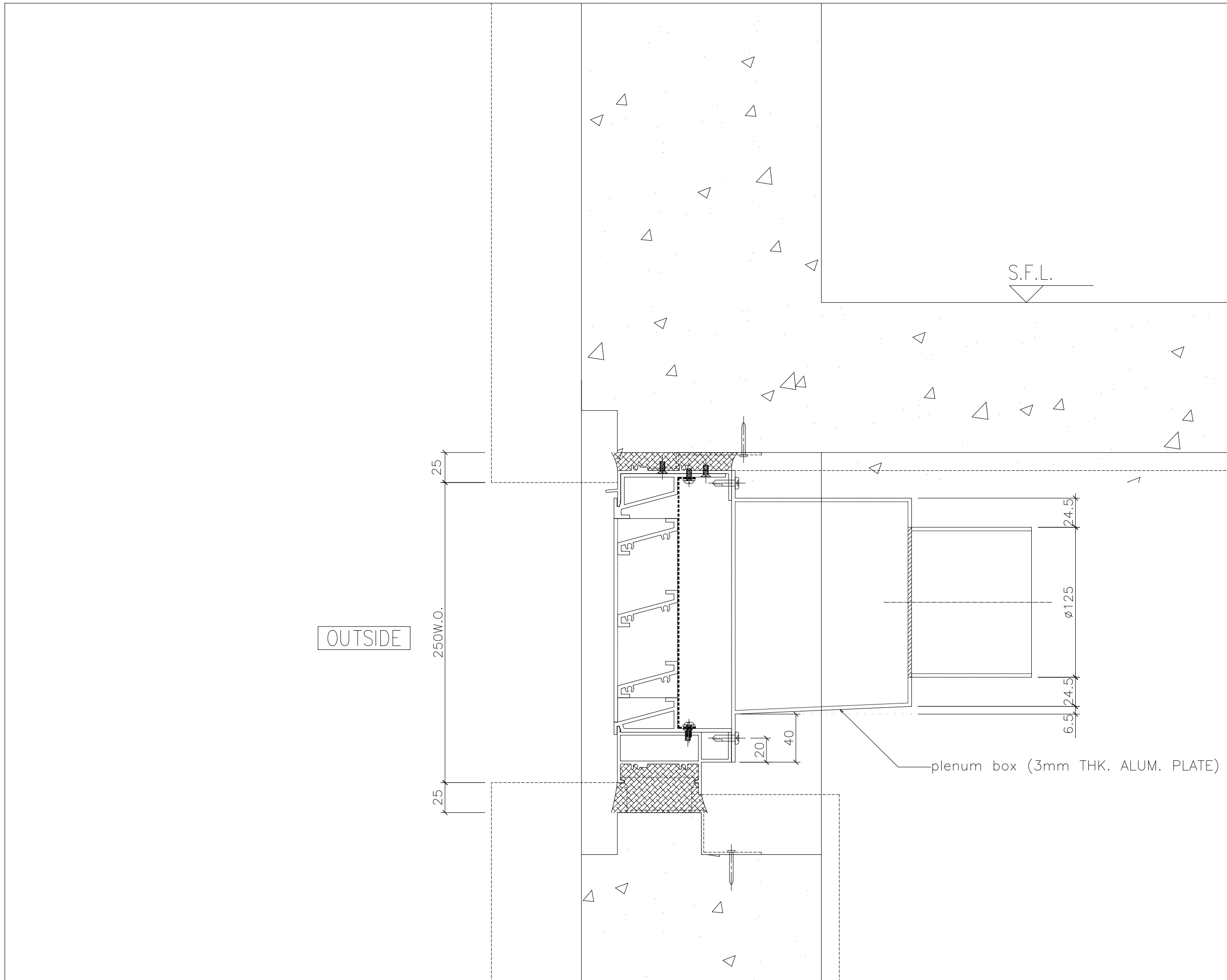

B.D. REF :

CLIENT :

ARCHITECT :
AGC DESIGN LTD
 101, 102, 103, 104, 105, 106, 107, 108, 109, 110, 111, 112, 113, 114, 115, 116, 117, 118, 119, 120, 121, 122, 123, 124, 125, 126, 127, 128, 129, 130, 131, 132, 133, 134, 135, 136, 137, 138, 139, 140, 141, 142, 143, 144, 145, 146, 147, 148, 149, 150, 151, 152, 153, 154, 155, 156, 157, 158, 159, 160, 161, 162, 163, 164, 165, 166, 167, 168, 169, 170, 171, 172, 173, 174, 175, 176, 177, 178, 179, 180, 181, 182, 183, 184, 185, 186, 187, 188, 189, 190, 191, 192, 193, 194, 195, 196, 197, 198, 199, 200, 201, 202, 203, 204, 205, 206, 207, 208, 209, 210, 211, 212, 213, 214, 215, 216, 217, 218, 219, 220, 221, 222, 223, 224, 225, 226, 227, 228, 229, 230, 231, 232, 233, 234, 235, 236, 237, 238, 239, 240, 241, 242, 243, 244, 245, 246, 247, 248, 249, 250, 251, 252, 253, 254, 255, 256, 257, 258, 259, 260, 261, 262, 263, 264, 265, 266, 267, 268, 269, 270, 271, 272, 273, 274, 275, 276, 277, 278, 279, 280, 281, 282, 283, 284, 285, 286, 287, 288, 289, 290, 291, 292, 293, 294, 295, 296, 297, 298, 299, 300, 301, 302, 303, 304, 305, 306, 307, 308, 309, 310, 311, 312, 313, 314, 315, 316, 317, 318, 319, 320, 321, 322, 323, 324, 325, 326, 327, 328, 329, 330, 331, 332, 333, 334, 335, 336, 337, 338, 339, 340, 341, 342, 343, 344, 345, 346, 347, 348, 349, 350, 351, 352, 353, 354, 355, 356, 357, 358, 359, 360, 361, 362, 363, 364, 365, 366, 367, 368, 369, 370, 371, 372, 373, 374, 375, 376, 377, 378, 379, 380, 381, 382, 383, 384, 385, 386, 387, 388, 389, 390, 391, 392, 393, 394, 395, 396, 397, 398, 399, 400, 401, 402, 403, 404, 405, 406, 407, 408, 409, 410, 411, 412, 413, 414, 415, 416, 417, 418, 419, 420, 421, 422, 423, 424, 425, 426, 427, 428, 429, 430, 431, 432, 433, 434, 435, 436, 437, 438, 439, 440, 441, 442, 443, 444, 445, 446, 447, 448, 449, 450, 451, 452, 453, 454, 455, 456, 457, 458, 459, 460, 461, 462, 463, 464, 465, 466, 467, 468, 469, 470, 471, 472, 473, 474, 475, 476, 477, 478, 479, 480, 481, 482, 483, 484, 485, 486, 487, 488, 489, 490, 491, 492, 493, 494, 495, 496, 497, 498, 499, 500, 501, 502, 503, 504, 505, 506, 507, 508, 509, 510, 511, 512, 513, 514, 515, 516, 517, 518, 519, 520, 521, 522, 523, 524, 525, 526, 527, 528, 529, 530, 531, 532, 533, 534, 535, 536, 537, 538, 539, 540, 541, 542, 543, 544, 545, 546, 547, 548, 549, 550, 551, 552, 553, 554, 555, 556, 557, 558, 559, 560, 561, 562, 563, 564, 565, 566, 567, 568, 569, 570, 571, 572, 573, 574, 575, 576, 577, 578, 579, 580, 581, 582, 583, 584, 585, 586, 587, 588, 589, 590, 591, 592, 593, 594, 595, 596, 597, 598, 599, 600, 601, 602, 603, 604, 605, 606, 607, 608, 609, 610, 611, 612, 613, 614, 615, 616, 617, 618, 619, 620, 621, 622, 623, 624, 625, 626, 627, 628, 629, 630, 631, 632, 633, 634, 635, 636, 637, 638, 639, 640, 641, 642, 643, 644, 645, 646, 647, 648, 649, 650, 651, 652, 653, 654, 655, 656, 657, 658, 659, 660, 661, 662, 663, 664, 665, 666, 667, 668, 669, 670, 671, 672, 673, 674, 675, 676, 677, 678, 679, 680, 681, 682, 683, 684, 685, 686, 687, 688, 689, 690, 691, 692, 693, 694, 695, 696, 697, 698, 699, 700, 701, 702, 703, 704, 705, 706, 707, 708, 709, 710, 711, 712, 713, 714, 715, 716, 717, 718, 719, 720, 721, 722, 723, 724, 725, 726, 727, 728, 729, 730, 731, 732, 733, 734, 735, 736, 737, 738, 739, 740, 741, 742, 743, 744, 745, 746, 747, 748, 749, 750, 751, 752, 753, 754, 755, 756, 757, 758, 759, 760, 761, 762, 763, 764, 765, 766, 767, 768, 769, 770, 771, 772, 773, 774, 775, 776, 777, 778, 779, 780, 781, 782, 783, 784, 785, 786, 787, 788, 789, 790, 791, 792, 793, 794, 795, 796, 797, 798, 799, 800, 801, 802, 803, 804, 805, 806, 807, 808, 809, 810, 811, 812, 813, 814, 815, 816, 817, 818, 819, 820, 821, 822, 823, 824, 825, 826, 827, 828, 829, 830, 831, 832, 833, 834, 835, 836, 837, 838, 839, 840, 841, 842, 843, 844, 845, 846, 847, 848, 849, 850, 851, 852, 853, 854, 855, 856, 857, 858, 859, 860, 861, 862, 863, 864, 865, 866, 867, 868, 869, 870, 871, 872, 873, 874, 875, 876, 877, 878, 879, 880, 881, 882, 883, 884, 885, 886, 887, 888, 889, 890, 891, 892, 893, 894, 895, 896, 897, 898, 899, 900, 901, 902, 903, 904, 905, 906, 907, 908, 909, 910, 911, 912, 913, 914, 915, 916, 917, 918, 919, 920, 921, 922, 923, 924, 925, 926, 927, 928, 929, 930, 931, 932, 933, 934, 935, 936, 937, 938, 939, 940, 941, 942, 943, 944, 945, 946, 947, 948, 949, 950, 951, 952, 953, 954, 955, 956, 957, 958, 959, 960, 961, 962, 963, 964, 965, 966, 967, 968, 969, 970, 971, 972, 973, 974, 975, 976, 977, 978, 979, 980, 981, 982, 983, 984, 985, 986, 987, 988, 989, 990, 991, 992, 993, 994, 995, 996, 997, 998, 999, 1000

MAIN CONTRACTOR :
Gammon

STRUCTURAL ENGINEER :
ARUP

FACADE CONSULTANT:
MEINHARDT

NOTE :

1. ALL DIMENSIONS ARE IN mm.
2. ALL ELEVATIONS ARE VIEWED FROM OUTSIDE.
3. ALL DIMENSIONS TO BE VERIFIED ON SITE BEFORE FABRICATION.

LEGEND :

(x1) — DETAIL MARK NO.
 (x001) — REFER SHEET NO.

1. F.F.L. -- FINISHED FLOOR LEVEL
2. S.F.L. -- STRUCTURAL FLOOR LEVEL
3. (R) -- REVERSED DETAIL

NO.	DATE	REVISED	BY
JOB NO. :		J-852	
PROJECT :			
PROPOSED RESIDENTIAL DEVELOPMENT AT 139 - 147 ARGYLE STREET, NKIL 6005, 6035 R.P., 6036 R.P., 6037 R.P. & 6038 R.P.			
TITLE :		DETAIL FOR Plenum Box	
DATE : 05-Dec-19		SCALE : 1:2	
DRAWN BY : MN		CHECKED BY : DW	
美特鋁質有限公司 MIDI ALUMINIUM FABRICATOR LTD. Units 6-8, Sunray Industrial Centre, 1/F 610 Cha Kwo Ling Road, Kowloon Tel:23489211-4 Fax:(852)2727666			
DWG NO. : J852-SD-PB-6007			REV. : -