

工程指示 / 要求簡箋(E.I.)

工程指示編號：EI / 2445 / 20

修改版次：

工程編號：J - 852

工程名稱：亞皆老街中電

工程項目：平台制房百葉地盤用防水片 (LV SWITCH ROOM 1) LG2

收件人：生統

發件人：Ant Yeung

日期：17/09/2020

要求提供 / 確認 事項：

- | | | |
|------------------------------------|-------------------------------------|-------------------------------|
| <input type="checkbox"/> 初步鋁料 B.M. | <input type="checkbox"/> 加工拆圖，然後生產 | <input type="checkbox"/> 尺寸表 |
| <input type="checkbox"/> 正式鋁料 B.M. | <input type="checkbox"/> 技術上資料 / 指示 | <input type="checkbox"/> 報價 |
| <input type="checkbox"/> 配件 B.M. | <input type="checkbox"/> 樣辦或貨品說明書 | <input type="checkbox"/> 分判合約 |
| <input type="checkbox"/> 其他：_____ | | |

內容：

請按此加工制房百葉地盤用防水片

本工程所有防水片用鉻化片

請在 2020.09.23 前完成上列要求。

附有關圖紙 / 文件：

以上項目為：

- 原合約工程包 原合約工程加 / 減賬 新工程報價

原因：-

分發東莞各部門：

- () 生產技術總監 連附件 () 技術部 連附件 () 生產部 連附件 () 機械設計部 連附件
 () 採購部 連附件 () 生產統籌部 連附件
 () 質檢部 連附件 () 會計部 連附件 () 報關組 連附件 () 其他 _____ 連附件

分發其他分判：

- (v) 水洪 連附件

分發香港各部門：

- () 行政部 連附件 () 會計部 連附件 () 統籌部 連附件 () 工程部地盤科文 連附件 祥哥
 () 採購部 連附件 () QS 部 連附件 () 維修部 連附件 () 其他 _____ 連附件

傳遞編號：

HK 2119 / 20

發件人簽署：

項目經理簽署：

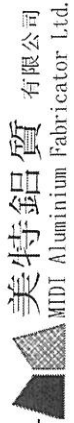

美特鋁質有限公司
MIDI Aluminium Fabricator Ltd.

工程號: J852
地盤名稱: 亞皆老街
項目類別: 平臺百頁樓梯防水片
修改版次:

計算: LHR
核對:
批准:

日期: 13/6/2020
日期:
日期:

送呈:
副本:

地盤用鋁板B.M.表

序號	修改內容	鋁板圖號	鋁板名稱	顏色	實用	後備	總數	總重量	總展開面積		總重量:	9.12	備註	位置				
									單件展開面積	總展開面積								
BM編號:													總重量:		9.12		此BM依據**拆圖資料計算	
A/C Code:													平方米		平方米			
1		LVA-API-04	1.5mm厚鋁板	MILL	4		4	2.730	0.168	0.672	0.000	0.000		詳見位置圖				
2		LVA-API-05	1.5mm厚鋁板	MILL	4		4	2.730	0.168	0.672	0.000	0.000		詳見位置圖				
3		LVA-API-06	1.5mm厚鋁板	MILL	4		4	1.830	0.113	0.450	0.000	0.000		詳見位置圖				
4		LVA-API-07	1.5mm厚鋁板	MILL	4		4	1.830	0.113	0.450	0.000	0.000		詳見位置圖				
5					0		0	0.000	0.000	0.000	0.000	0.000						
6					0		0	0.000	0.000	0.000	0.000	0.000						
7					0		0	0.000	0.000	0.000	0.000	0.000						
8					0		0	0.000	0.000	0.000	0.000	0.000						
9					0		0	0.000	0.000	0.000	0.000	0.000						
10					0		0	0.000	0.000	0.000	0.000	0.000						
11					0		0	0.000	0.000	0.000	0.000	0.000						
12					0		0	0.000	0.000	0.000	0.000	0.000						
13					0		0	0.000	0.000	0.000	0.000	0.000						
14					0		0	0.000	0.000	0.000	0.000	0.000						
15					0		0	0.000	0.000	0.000	0.000	0.000						
總計: 16													9.12	2.24	0.00			



美特鋁質 有限公司
MIDI Aluminium Fabricator Ltd.

工程號 J852 | 地盤 | 亞皆老街

地盤用

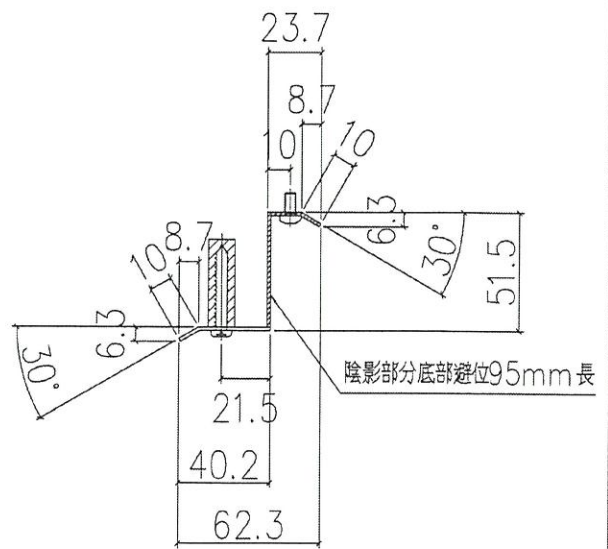
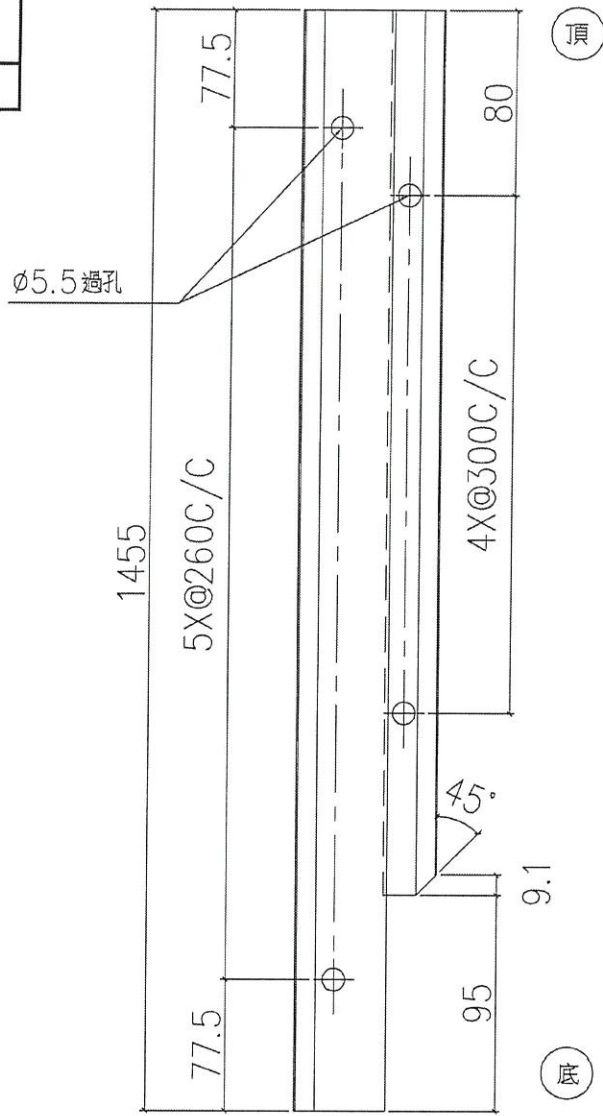

序號	物料編號	數量	使用位置	樓層
01	LVA-AP1-04	4	AL-501c,501d	LG2

名稱	防水片拆圖	制圖	LHR	2020.06.12	修改		
材料	1.5mm 鋁板	復核	-	-	日期		
顏色	MILK	批准			圖號	J852-LVA-AP1-04	

 美特鋁質 有限公司
MIDI Aluminium Fabricator Ltd.

工程號 J852 | 地盤 | 亞皆老街

地盤用

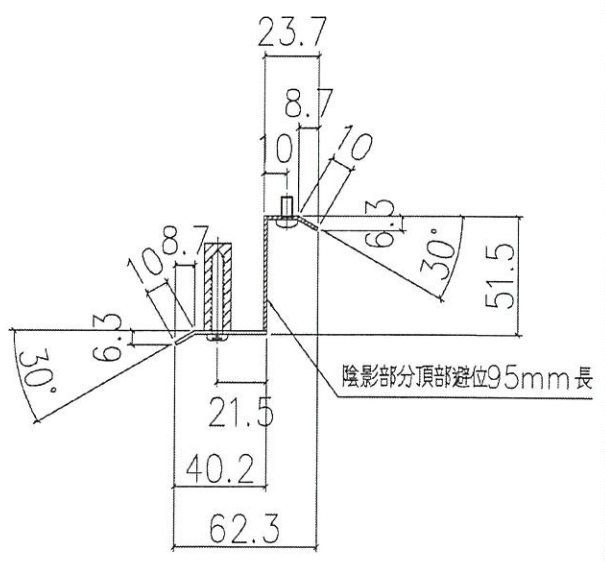
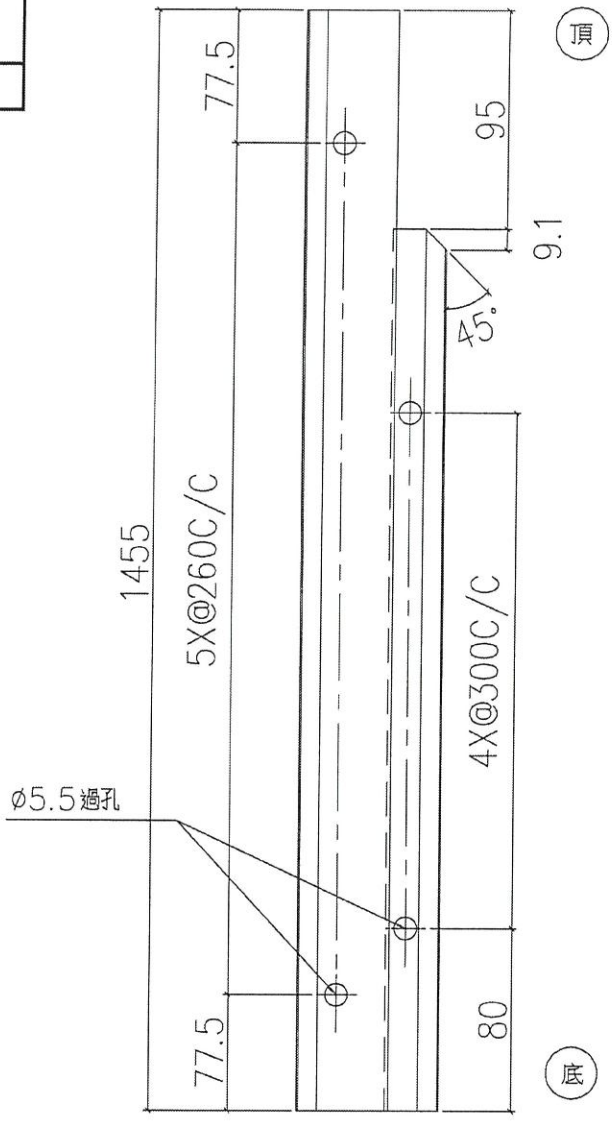

序號	物料編號	數量	使用位置	樓層
01	LVA-AP1-05	4	AL-501c,501d	LG2

名稱	防水片拆圖	制圖	LHR	2020.06.12	修改			
材料	1.5mm 鋁板	復核	-	-	日期			
顏色	MIL	批准			圖號	J852-LVA-AP1-05		

Handwritten signature



美特鋁質 有限公司
MIDI Aluminium Fabricator Ltd.

工程號 J852 | 地盤 亞皆老街

地盤用

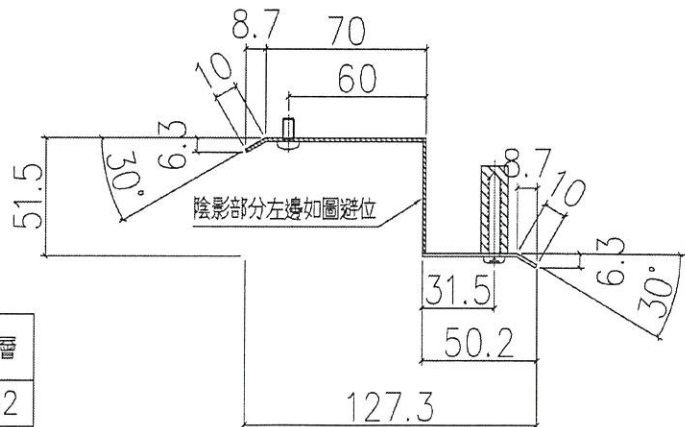
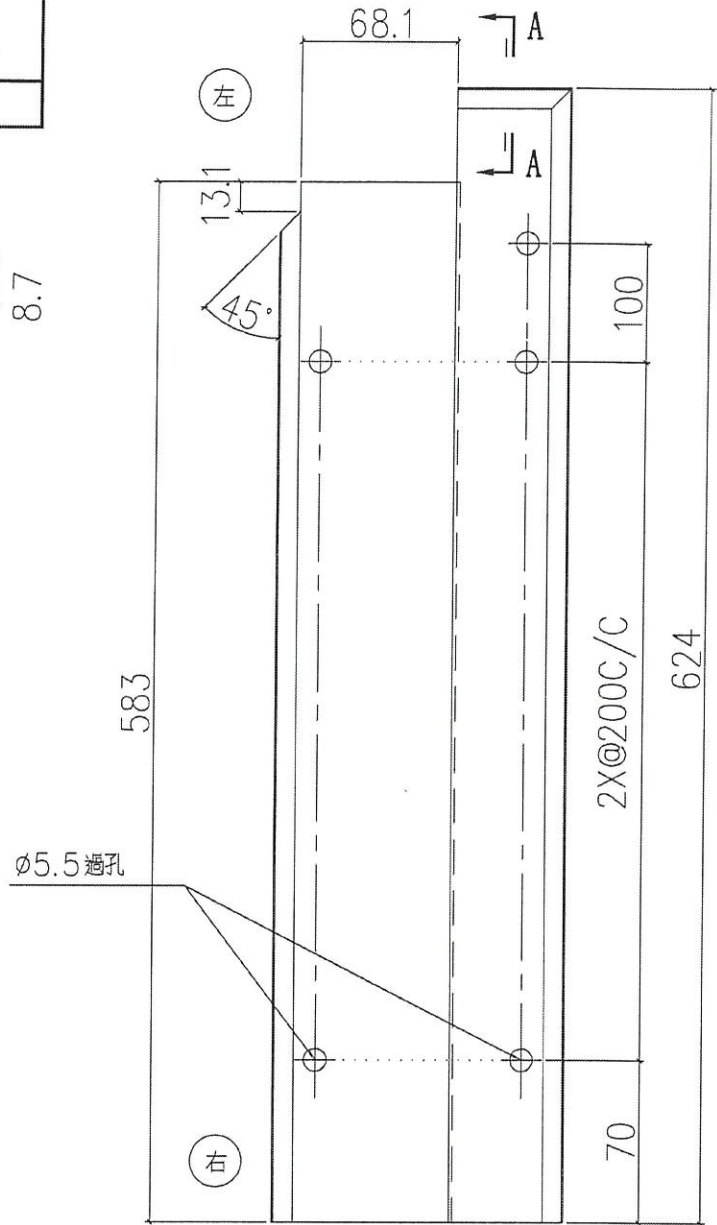
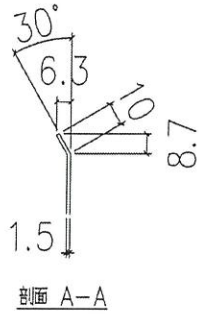

序號	物料編號	數量	使用位置	樓層
01	LVA-AP1-06	4	AL-501c,501d	LG2

名稱	防水片拆圖	制圖	LHR	2020.06.12	修改		
材料	1.5mm 鋁板	復核	-	-	日期		
顏色	MtL <i>Handwritten signature</i>	批准			圖號	J852-LVA-AP1-06	

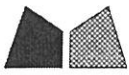

美特鋁質 有限公司
MIDI Aluminium Fabricator Ltd.

工程號 J852 | 地盤 亞皆老街

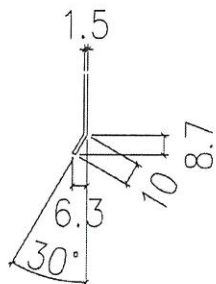
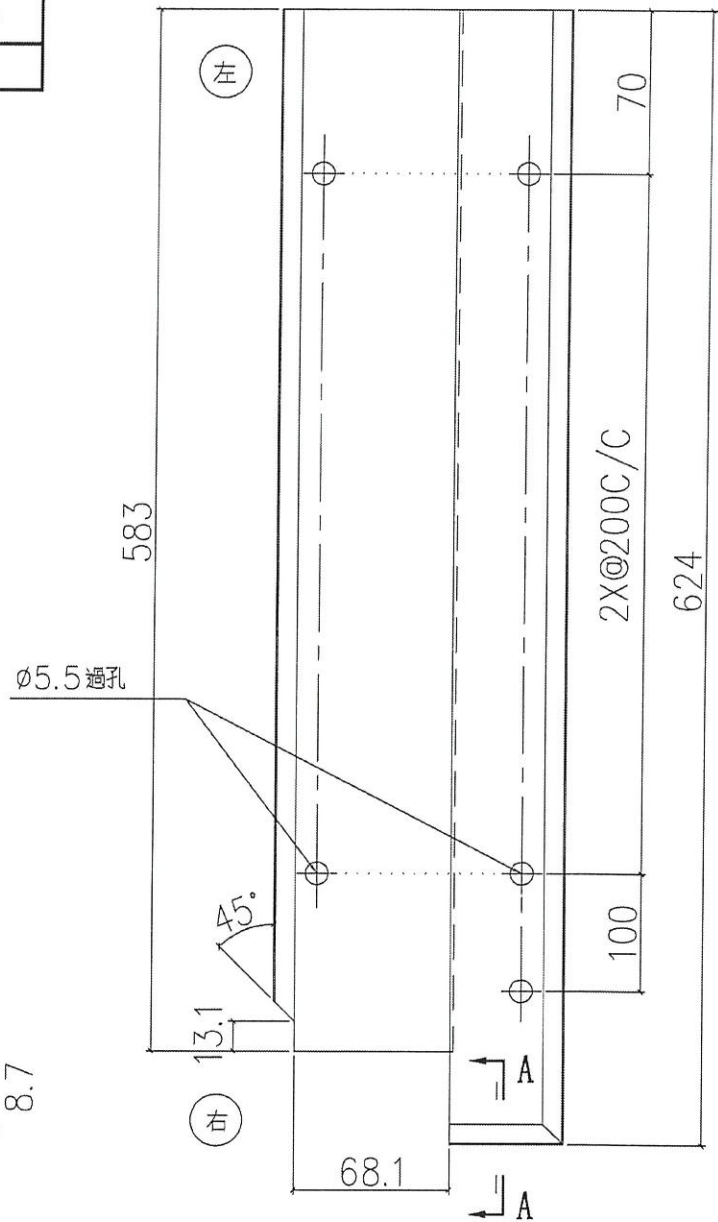

剖面 A-A

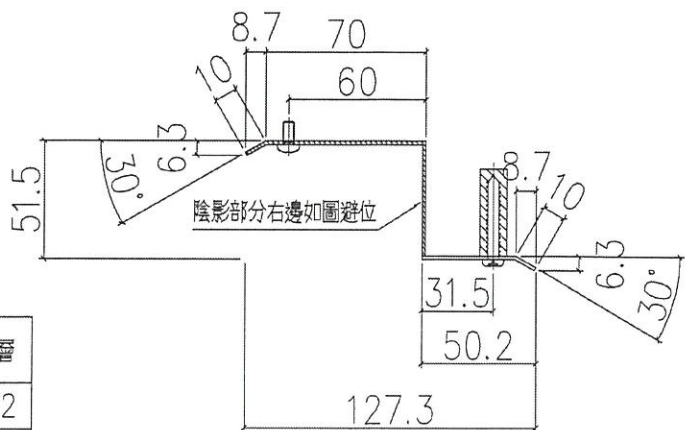

序號	物料編號	數量	使用位置	樓層
01	LVA-AP1-07	4	AL-501c,501d	LG2

名稱	防水片拆圖	制圖	LHR	2020.06.12	修改		
材料	1.5mm 鋁板	復核	-	-	日期		
顏色	MILL	批准			圖號	J852-LVA-AP1-07	

派位圖

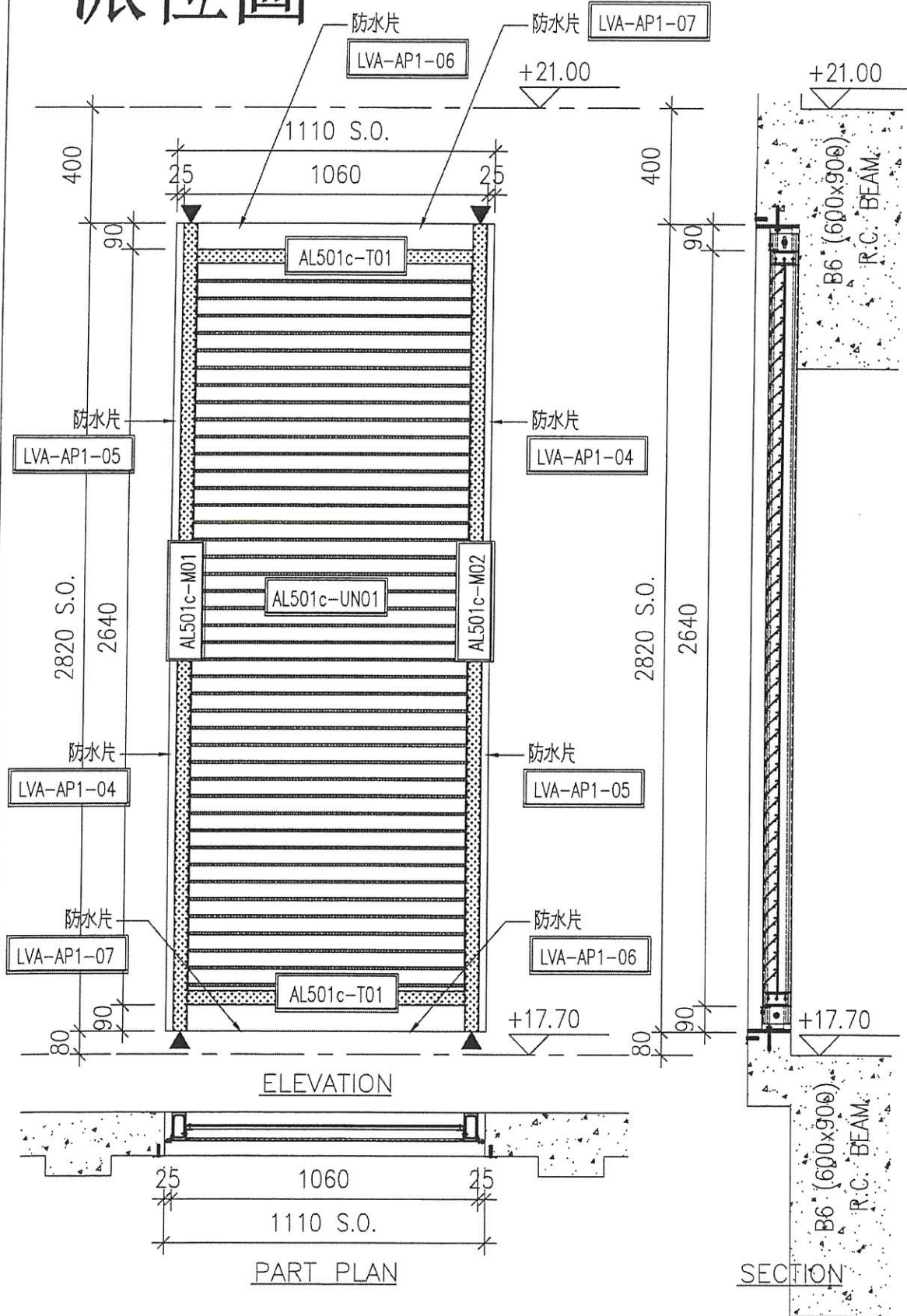

ELEVATION

PART PLAN

SECTION

AL-501c

LG2/F

LV SWITCH ROOM 1

1

WEATHERPROOF LOUVER (60% FREE AREA)

派位圖

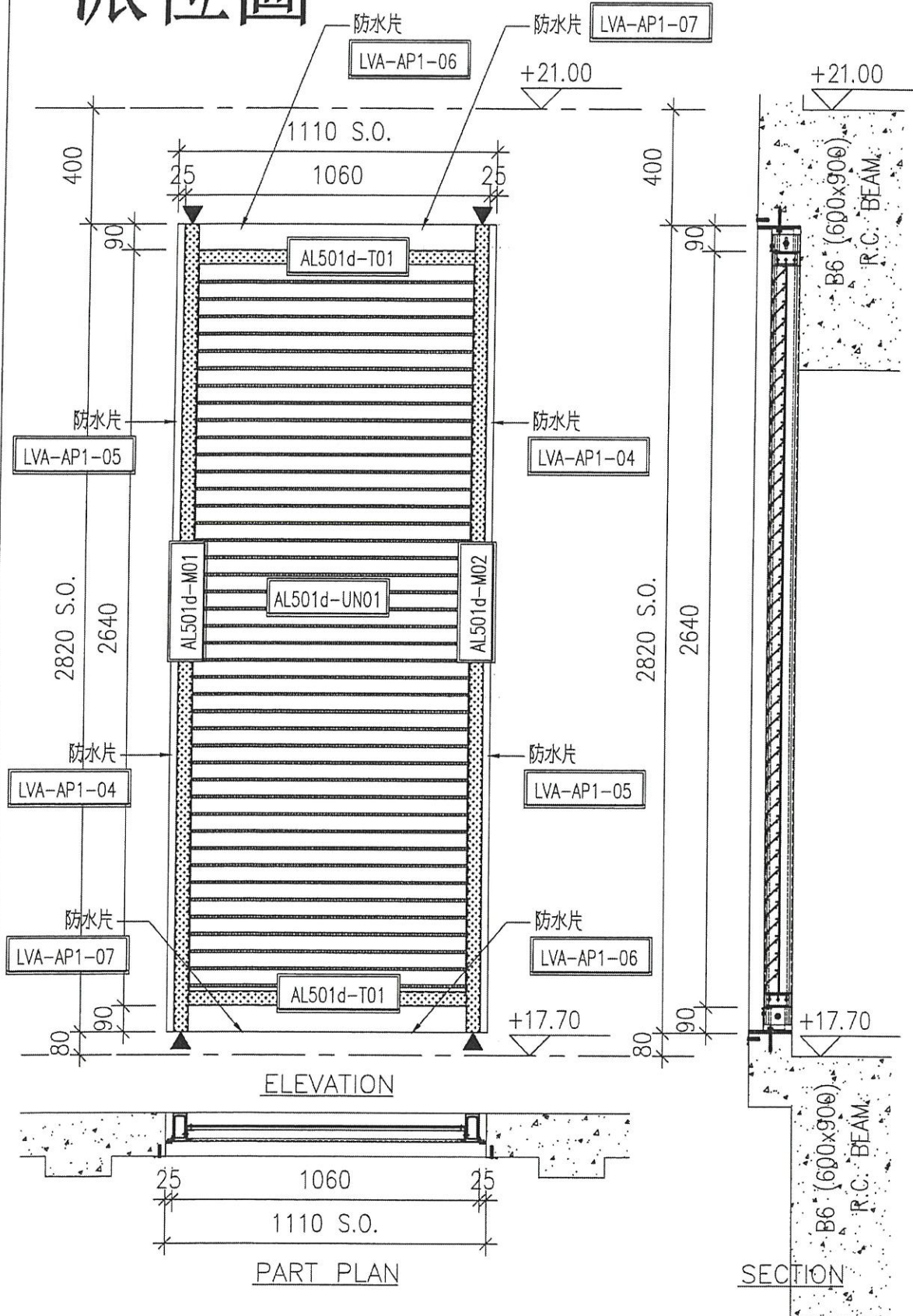

AL-501d

LG2/F

LV SWITCH ROOM 1

1

WEATHERPROOF LOUVER (60% FREE AREA)

R.O. REF :

CUSTOM :

ARCHITECT :
AGC
REGISTERED ARCHITECTS
100, 102, 104, 106, 108, 110, 112, 114, 116, 118, 120, 122, 124, 126, 128, 130, 132, 134, 136, 138, 140, 142, 144, 146, 148, 150, 152, 154, 156, 158, 160, 162, 164, 166, 168, 170, 172, 174, 176, 178, 180, 182, 184, 186, 188, 190, 192, 194, 196, 198, 200, 202, 204, 206, 208, 210, 212, 214, 216, 218, 220, 222, 224, 226, 228, 230, 232, 234, 236, 238, 240, 242, 244, 246, 248, 250, 252, 254, 256, 258, 260, 262, 264, 266, 268, 270, 272, 274, 276, 278, 280, 282, 284, 286, 288, 290, 292, 294, 296, 298, 300, 302, 304, 306, 308, 310, 312, 314, 316, 318, 320, 322, 324, 326, 328, 330, 332, 334, 336, 338, 340, 342, 344, 346, 348, 350, 352, 354, 356, 358, 360, 362, 364, 366, 368, 370, 372, 374, 376, 378, 380, 382, 384, 386, 388, 390, 392, 394, 396, 398, 400, 402, 404, 406, 408, 410, 412, 414, 416, 418, 420, 422, 424, 426, 428, 430, 432, 434, 436, 438, 440, 442, 444, 446, 448, 450, 452, 454, 456, 458, 460, 462, 464, 466, 468, 470, 472, 474, 476, 478, 480, 482, 484, 486, 488, 490, 492, 494, 496, 498, 500, 502, 504, 506, 508, 510, 512, 514, 516, 518, 520, 522, 524, 526, 528, 530, 532, 534, 536, 538, 540, 542, 544, 546, 548, 550, 552, 554, 556, 558, 560, 562, 564, 566, 568, 570, 572, 574, 576, 578, 580, 582, 584, 586, 588, 590, 592, 594, 596, 598, 600, 602, 604, 606, 608, 610, 612, 614, 616, 618, 620, 622, 624, 626, 628, 630, 632, 634, 636, 638, 640, 642, 644, 646, 648, 650, 652, 654, 656, 658, 660, 662, 664, 666, 668, 670, 672, 674, 676, 678, 680, 682, 684, 686, 688, 690, 692, 694, 696, 698, 700, 702, 704, 706, 708, 710, 712, 714, 716, 718, 720, 722, 724, 726, 728, 730, 732, 734, 736, 738, 740, 742, 744, 746, 748, 750, 752, 754, 756, 758, 760, 762, 764, 766, 768, 770, 772, 774, 776, 778, 780, 782, 784, 786, 788, 790, 792, 794, 796, 798, 800, 802, 804, 806, 808, 810, 812, 814, 816, 818, 820, 822, 824, 826, 828, 830, 832, 834, 836, 838, 840, 842, 844, 846, 848, 850, 852, 854, 856, 858, 860, 862, 864, 866, 868, 870, 872, 874, 876, 878, 880, 882, 884, 886, 888, 890, 892, 894, 896, 898, 900, 902, 904, 906, 908, 910, 912, 914, 916, 918, 920, 922, 924, 926, 928, 930, 932, 934, 936, 938, 940, 942, 944, 946, 948, 950, 952, 954, 956, 958, 960, 962, 964, 966, 968, 970, 972, 974, 976, 978, 980, 982, 984, 986, 988, 990, 992, 994, 996, 998, 1000

MAIN CONTRACTOR :



STRUCTURAL ENGINEER :



FACADE CONSULTANT :



NOTE :
1. ALL DIMENSIONS ARE IN mm.
2. ALL ELEVATIONS ARE VIEWED FROM OUTSIDE.
3. ALL DIMENSIONS TO BE VIEWED ON SITE.
BEFORE FABRICATION.

LEGEND :
1. F.F.L. --- FINISHED FLOOR LEVEL
2. S.F.L. --- STRUCTURAL FLOOR LEVEL
3. --- REVERSED DETAIL

--- DETAIL MARK NO.
--- REFER SHEET NO.

REVISIONS
NO. DATE BY REASON

DATE : 27/01/2020
GENERAL REVISED
A 19/02/2020
GENERAL REVISED

JOB NO. : J-RS2

PROJECT :
PROPOSED RESIDENTIAL DEVELOPMENT
AT 139 - 147 ARGYLE STREET,
MKL 6005, 6035 R.P., 6036 R.P.,
6037 R.P. & 6038 R.P.

TITLE :
LOCATION PLAN OF
ALUM. LOUVER
AT LG2/F

DATE : 9-Jan-2020 SCALE : 1:200

DRAWN BY : LHR CHECKED BY : DW

UNITED ALUMINIUM INDUSTRIES LTD.
Units 6-8, Sorely Industrial Centre, 1/1
100 Chin Kee Ung Road, Kowloon
TEL: 230821-4 Fax: (852) 2727665
DWG NO. : JRS2-S0-LVA-3001 REV. : B

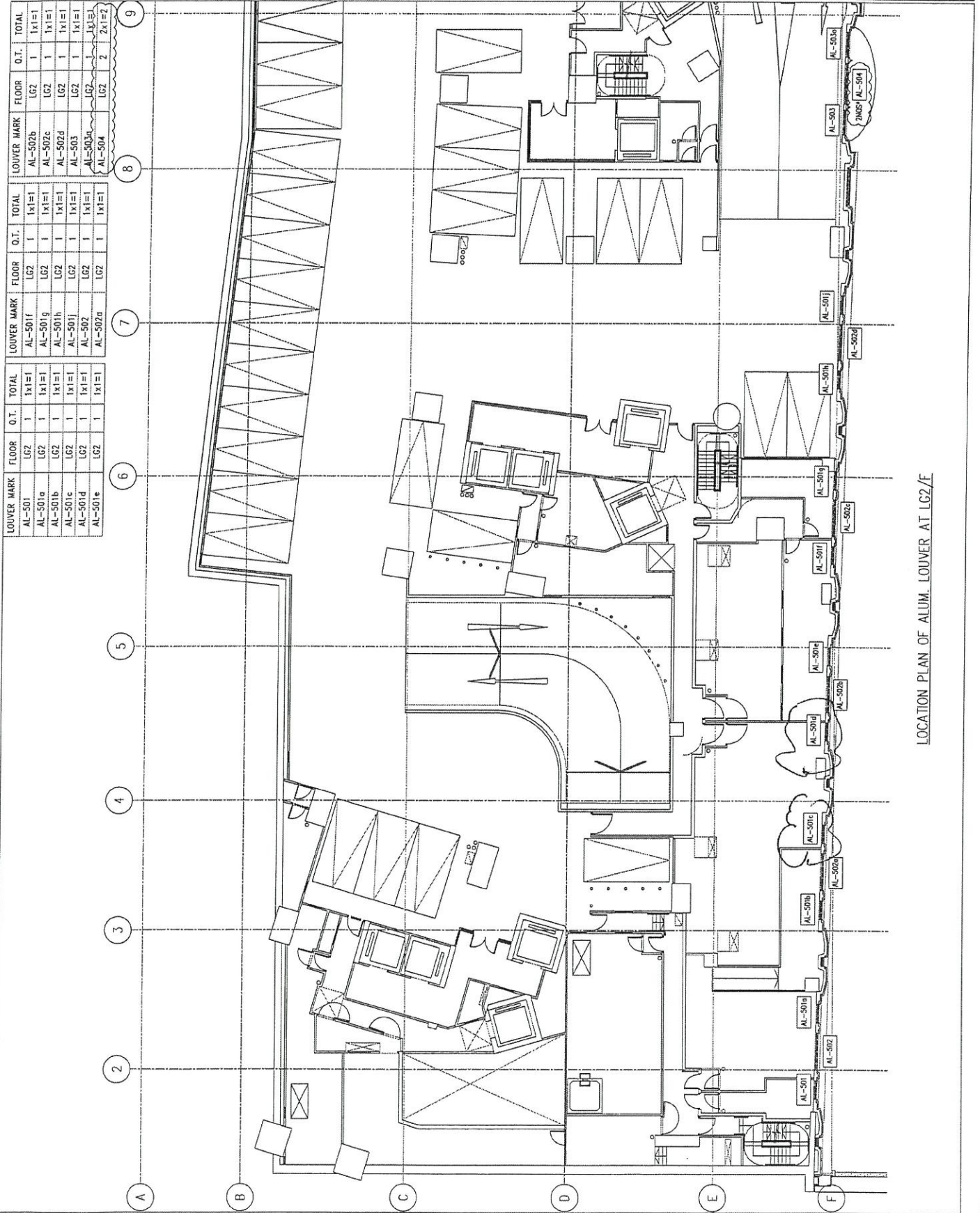

LOUVER MARK	FLOOR	Q.T.	TOTAL	LOUVER MARK	FLOOR	Q.T.	TOTAL	LOUVER MARK	FLOOR	Q.T.	TOTAL
AL-501	LG2	1	1x1=1	AL-501f	LG2	1	1x1=1	AL-502b	LG2	1	1x1=1
AL-501a	LG2	1	1x1=1	AL-501g	LG2	1	1x1=1	AL-502c	LG2	1	1x1=1
AL-501b	LG2	1	1x1=1	AL-501h	LG2	1	1x1=1	AL-502d	LG2	1	1x1=1
AL-501c	LG2	1	1x1=1	AL-501i	LG2	1	1x1=1	AL-503	LG2	1	1x1=1
AL-501d	LG2	1	1x1=1	AL-502	LG2	1	1x1=1	AL-503a	LG2	1	1x1=1
AL-501e	LG2	1	1x1=1	AL-502a	LG2	1	1x1=1	AL-503b	LG2	1	1x1=1
AL-502	LG2	1	1x1=1	AL-502b	LG2	1	1x1=1	AL-503c	LG2	1	1x1=1
AL-502a	LG2	1	1x1=1	AL-502c	LG2	1	1x1=1	AL-503d	LG2	1	1x1=1
AL-502b	LG2	1	1x1=1	AL-502d	LG2	1	1x1=1	AL-504	LG2	2	2x1=2
AL-502c	LG2	1	1x1=1	AL-502e	LG2	1	1x1=1				
AL-502d	LG2	1	1x1=1	AL-502f	LG2	1	1x1=1				
AL-502e	LG2	1	1x1=1	AL-502g	LG2	1	1x1=1				
AL-502f	LG2	1	1x1=1	AL-502h	LG2	1	1x1=1				
AL-502g	LG2	1	1x1=1	AL-502i	LG2	1	1x1=1				
AL-502h	LG2	1	1x1=1	AL-502j	LG2	1	1x1=1				
AL-502i	LG2	1	1x1=1	AL-502k	LG2	1	1x1=1				
AL-502j	LG2	1	1x1=1	AL-502l	LG2	1	1x1=1				
AL-502k	LG2	1	1x1=1	AL-502m	LG2	1	1x1=1				
AL-502l	LG2	1	1x1=1	AL-502n	LG2	1	1x1=1				
AL-502m	LG2	1	1x1=1	AL-502o	LG2	1	1x1=1				
AL-502n	LG2	1	1x1=1	AL-502p	LG2	1	1x1=1				
AL-502o	LG2	1	1x1=1	AL-502q	LG2	1	1x1=1				
AL-502p	LG2	1	1x1=1	AL-502r	LG2	1	1x1=1				
AL-502q	LG2	1	1x1=1	AL-502s	LG2	1	1x1=1				
AL-502r	LG2	1	1x1=1	AL-502t	LG2	1	1x1=1				
AL-502s	LG2	1	1x1=1	AL-502u	LG2	1	1x1=1				
AL-502t	LG2	1	1x1=1	AL-502v	LG2	1	1x1=1				
AL-502u	LG2	1	1x1=1	AL-502w	LG2	1	1x1=1				
AL-502v	LG2	1	1x1=1	AL-502x	LG2	1	1x1=1				
AL-502w	LG2	1	1x1=1	AL-502y	LG2	1	1x1=1				
AL-502x	LG2	1	1x1=1	AL-502z	LG2	1	1x1=1				
AL-502y	LG2	1	1x1=1								
AL-502z	LG2	1	1x1=1								

LOCATION PLAN OF ALUM. LOUVER AT LG2/F

Hung

了批

2020.9.17

- Polyamide nylon shall be reinforced with glass fibres and shall be mechanically locked to extrusions with closely spaced crimps.
- Polyurethane shall be poured into a cavity of a single extrusion. The extrusion shall be de-bridged after the polyurethane hardens. The cavity shall have closely spaced indentions to mechanically lock the polyurethane against slippage in the cavity.
- Thermal breaks that are clamped between two layers of metal with fasteners shall be rigid PVC or one of the materials specified for glazing gaskets in this specification.
- Thermal breaks shall not split, crack or fracture. Thermal breaks shall not experience shrinkage or other deformation to the extent that frames are distorted or water leakage occurs. Extruded aluminium frames with integral thermal breaks shall conform to specified tolerances for one-piece aluminium extrusions.
- Thermal brakes shall have the same strength and rigidity as the aluminium section that it separates.

557 FLASHING

A. GENERAL

- Provide all required flashings, baffles, trims, cappings and the like to prevent the entry of water and weather, and make neat and clean junctions with the base structure and adjoining work. Where visible, provide matching materials and finishes. Include all fixings and sealing.
- All flashings shall be cut and folded to approved profiles out of non-corrosive materials (i.e. aluminium and stainless steel grade 316), with protective coatings as required. Flashings shall be factory fabricated in long lengths where practical, and pre-painted on visible surfaces. Submit details.
- Flashings shall occur on the warm side of insulation.
- Flashing is not acceptable as a vapour barrier.

所有防水片

用铝化片

BM 註明
如圖
2/3

銘心

顧問拒絕收貨 Mill.