

工程指示 / 要求簡箋(E.I.)

工程指示編號：EI / 2067 / 20

修改版次：-

工程編號：J - 852

工程名稱：亞皆老街中電

工程項目：後裝窗 FD 門 趟門- 繪畫模圖 (50 個)

x f s f 42 - x f s f 91

收件人：Maggie / 生統

發件人：Ant Yeung

日期：09/07/2020

要求提供 / 確認 事項：

- | | | |
|------------------------------------|-------------------------------------|-------------------------------|
| <input type="checkbox"/> 初步鋁料 B.M. | <input type="checkbox"/> 加工拆圖，然後生產 | <input type="checkbox"/> 尺寸表 |
| <input type="checkbox"/> 正式鋁料 B.M. | <input type="checkbox"/> 技術上資料 / 指示 | <input type="checkbox"/> 報價 |
| <input type="checkbox"/> 配件 B.M. | <input type="checkbox"/> 樣辦或貨品說明書 | <input type="checkbox"/> 分判合約 |

內容：

請繪畫加工模圖共 50 個作後裝窗 FD 門 趟門 開模用。

請在 2020 / 07 / 13 前完成上列要求。

附：1+ 50 頁

以上項目為：

- 原合約工程包 原合約工程加 / 減賬 新工程報價

原因：-

分發東莞各部門：

- () 生產技術總監 連附件 () 技術部 連附件 () 生產部 連附件 () 機械設計部 連附件
 () 採購部 連附件 () 生產統籌部 連附件
 () 質檢部 連附件 () 會計部 連附件 () 報關組 連附件 () 其他 楊榮輝 連附件

分發其他分判：

- (v) 水洪 連附件

分發香港各部門：

- () 行政部 連附件 () 會計部 連附件 () 統籌部 連附件 () 工程部地盤科文 連附件
 () 採購部 連附件 () QS 部 連附件 () 維修部 連附件 () 其他 _____ 連附件

傳遞編號：

HK 1328 / 20

發件人簽署：
Ant Yeung

項目經理簽署：
Ant Yeung

CUSTOMER	CUSTOMER APPROVAL <i>2207</i> <i>HK1328</i>	CUST PART NO.	AL-IW01(0)
		SECTION NO.	<i>X-25842</i>

a=0.1r
b=0.2r
c=0.3r
d=0.4r
e=0.5r
f=0.8r

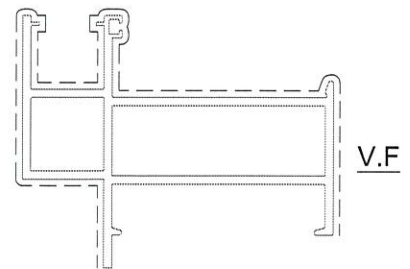
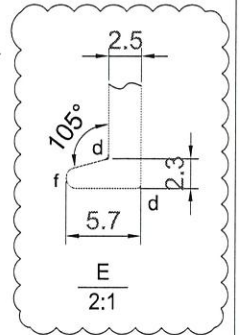
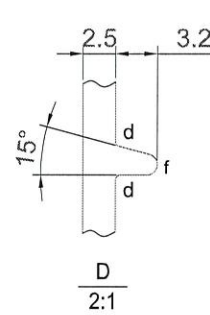
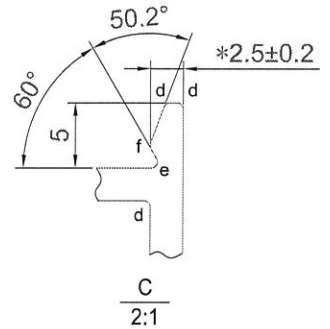
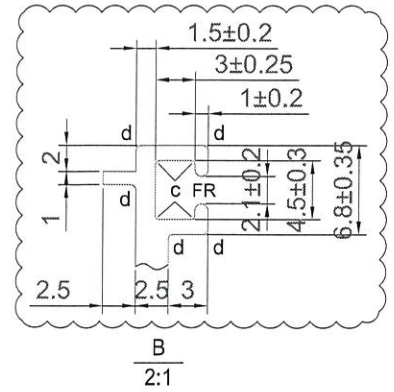
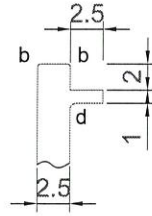
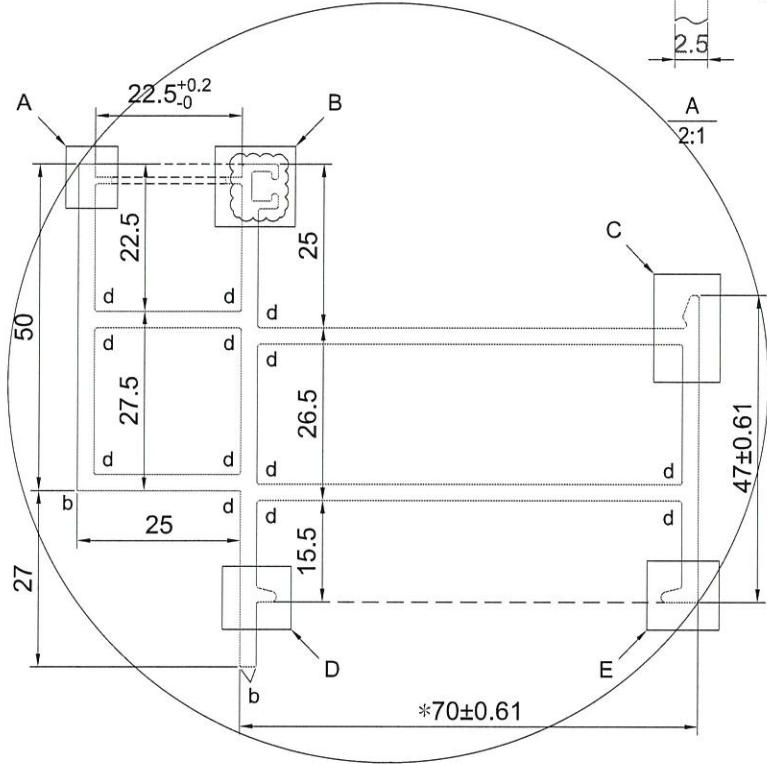

SCALE 1:2

美特鋁質有限公司
承認圖面
日期 9-7-20

SIGNATURE GRADEING	HIGH SIGNATURE GRADEING	C.C.DIA(MM)	116.25							
AREA (SQ MM)	891.07	UNSPECIFIED THICKNESS	2.5		PERIMETER (MM)	463.64	STANDARD	SCALE	1:1	
MASS (KG/M)	2.415	UNSPECIFIED CORNERS	-		SURFACE AREA	344.11	ALLOY	6063-T6	VERSION	A
COMPANY ISSUE		DRAWN	LHR	DATE	2020-02-29	APPELLATION		PAGE OF		
		STANDARDIZATION		DATE						
		TO SIGN		DATE						
		AUDITING		DATE						
MARKER	MODIFY	FILE NO	SIGNATURE	DATE	APPROV					

美特鋁質有限公司
MIDI Aluminium Fabricator Ltd.

CUSTOMER	CUSTOMER APPROVAL	CUST PART NO.	AL-IW01B(0)
		SECTION NO.	X-8843

a=0.1r
b=0.2r
c=0.3r
d=0.4r
e=0.5r
f=0.8r

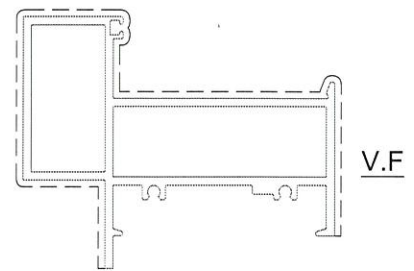
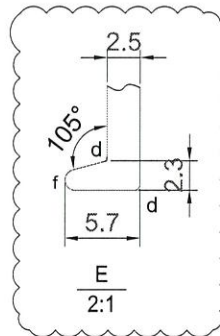
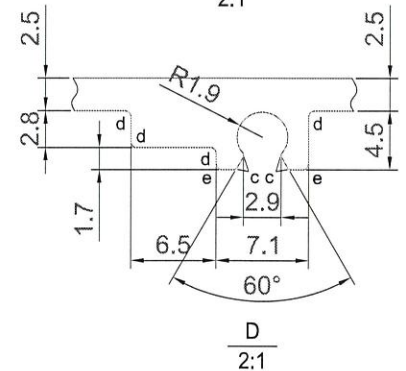
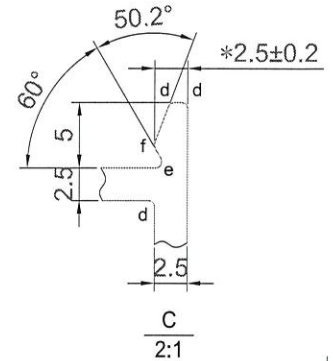
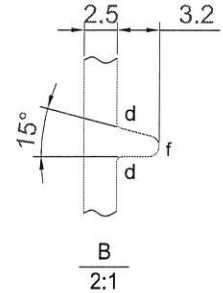
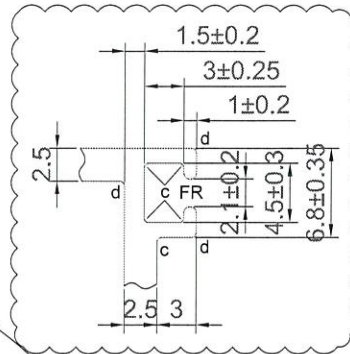
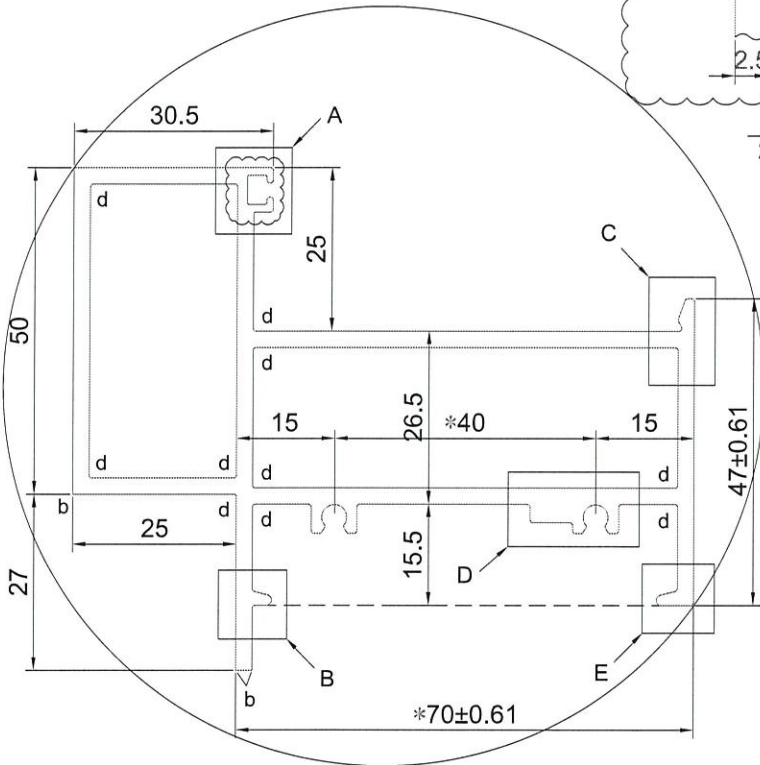

美特鋁質有限公司
承認圖面
日期 P-7-20

SCALE 1:2

SIGNATURE GRADEING	HIGH SIGNATURE GRADEING	C.C.DIA(MM)	116.25						
AREA (SQ MM)	938.58	UNSPECIFIED THICKNESS	2.5	PERIMETER (MM)	440.73	STANDARD		SCALE	1:1
MASS (KG/M)	2.544	UNSPECIFIED CORNERS	-	SURFACE AREA	290.14	ALLOY	6063-T6	VERSION	A
COMPANY ISSUE			DRAWA	LHR	DATE	APELATION		PAGE OF	
			STANDA-RDIZATION		DATE				
			TO SIGN		DATE				
			AUDITING		DATE				
MARKER	MODIFY	FILE NO	SIGNATURE	DATE	APPROV				

美特鋁質有限公司
MIDI Aluminium Fabricator Ltd.

CUSTOMER	CUSTOMER APPROVAL	CUST PART NO.	AL-IW01T(0)
		SECTION NO.	XJ8844

a=0.1r
b=0.2r
c=0.3r
d=0.4r
e=0.5r
f=0.8r

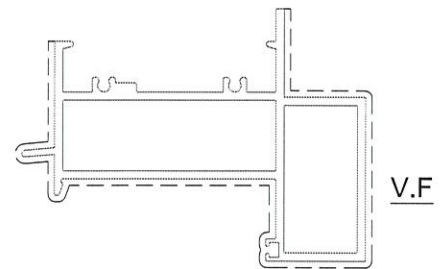
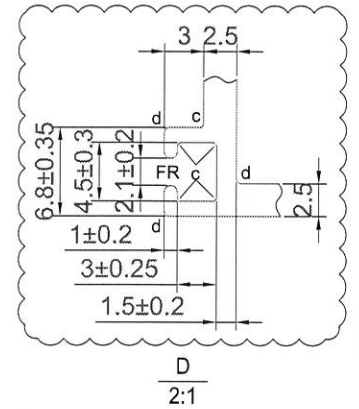
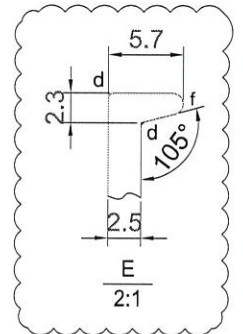
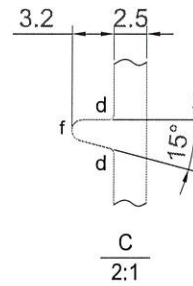
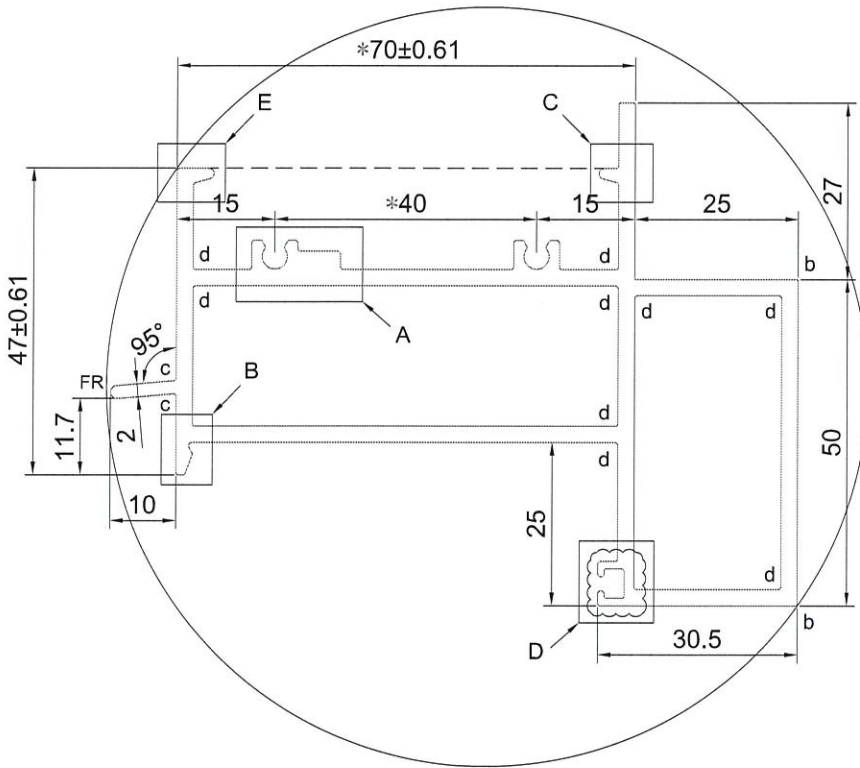
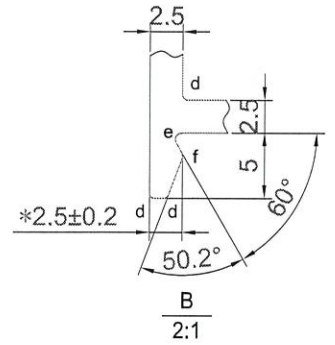
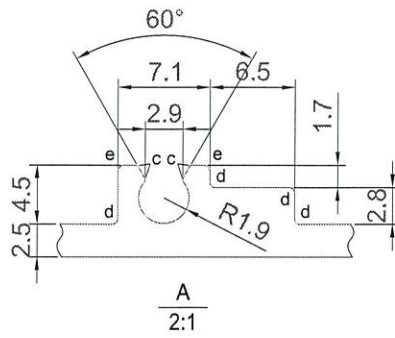

SCALE 1:2

美特鋁質有限公司
承認圖面
日期 1-7-20

SIGNATURE GRADEING	HIGH SIGNATURE GRADEING	C.C.DIA(MM)	116.25						
AREA (SQ MM)	958.26	UNSPECIFIED THICKNESS	2.5	PERIMETER (MM)	459.68	STANDARD		SCALE	1:1
MASS (KG/M)	2.597	UNSPECIFIED CORNERS	-	SURFACE AREA	309.09	ALLOY	6063-T6	VERSION	A
COMPANY ISSUE			DRAWA	LHR	DATE	APELATION		PAGE OF	
			STANDA-RDIZATION		DATE				
			TO SIGN		DATE				
			AUDITING		DATE				
MARKER	MODIFY	FILE NO	SIGNATURE	DATE	APPROV				

美特鋁質有限公司
MIDI Aluminium Fabricator Ltd.

3

CUSTOMER	CUSTOMER APPROVAL	CUST PART NO.	AL-IW02(0)
		SECTION NO.	<i>Handwritten</i>

$a=0.1r$
 $b=0.2r$
 $c=0.3r$
 $d=0.4r$
 $e=0.5r$
 $f=0.8r$

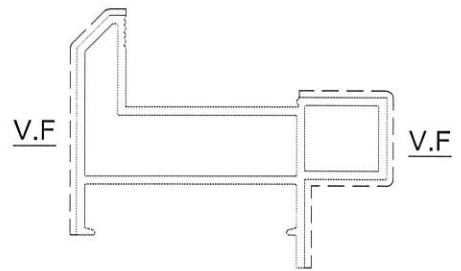
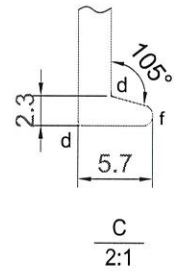
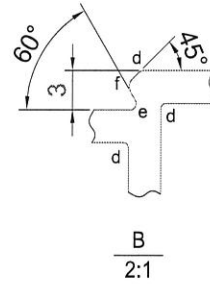
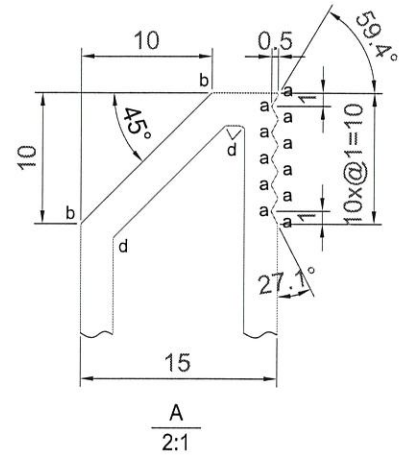
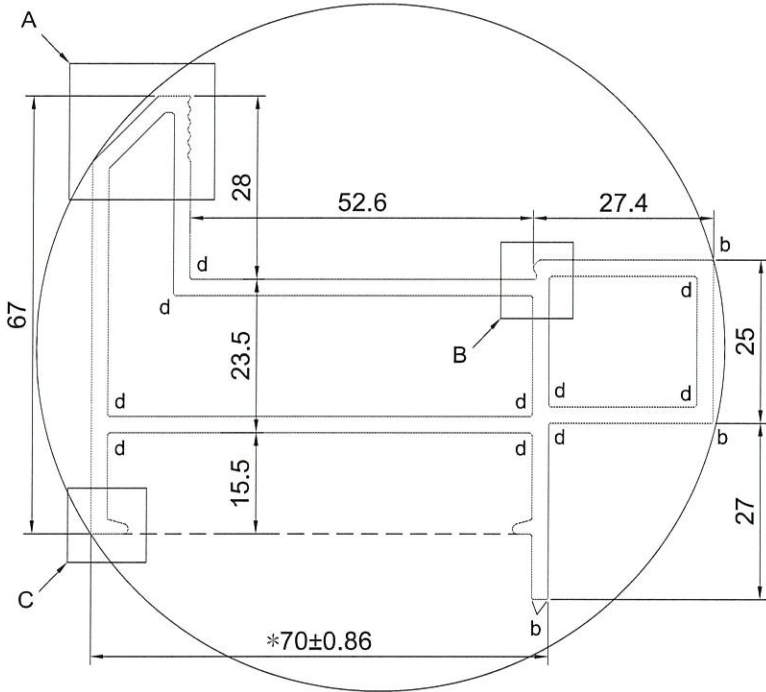

SCALE 1:2

美特鋁質有限公司
 承認圖面
 日期 8-7-20

SIGNATURE GRADEING	HIGH SIGNATURE GRADEING	C.C.DIA(MM)	105.16						
AREA (SQ MM)	861.56	UNSPECIFIED THICKNESS	2.5	PERIMETER (MM)	384.61	STANDARD		SCALE	1:1
MASS (KG/M)	2.335	UNSPECIFIED CORNERS	-	SURFACE AREA	180.04	ALLOY	6063-T6	VERSION	
COMPANY ISSUE			DRAWA	LHR	DATE	2020-02-29	APELLATION	PAGE OF	
			STANDA-RDIZATION		DATE				
			TO SIGN		DATE				
			AUDITING		DATE				
MARKER	MODIFY	FILE NO	SIGNATURE	DATE	APPROV	DATE			

美特鋁質有限公司
 MIDI Aluminium Fabricator Ltd.

4

CUSTOMER	CUSTOMER APPROVAL	CUST PART NO.	AL-IW02B(0)
		SECTION NO.	X-85846

$a=0.1r$
 $b=0.2r$
 $c=0.3r$
 $d=0.4r$
 $e=0.5r$
 $f=0.8r$

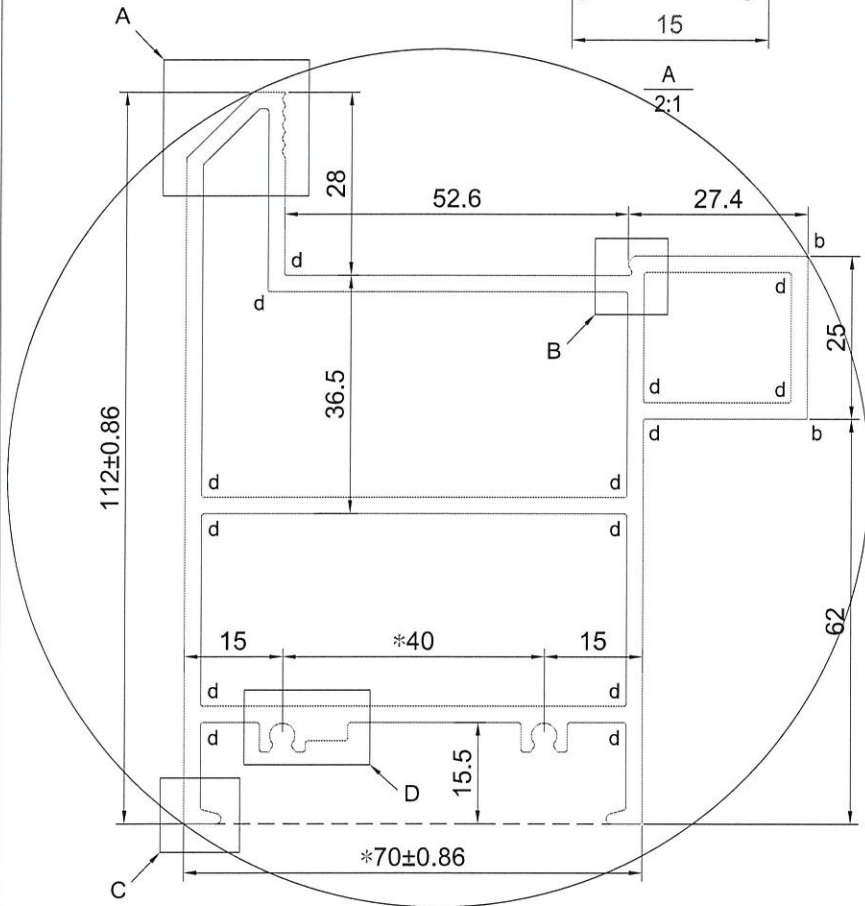
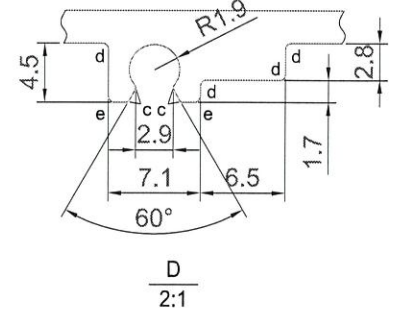
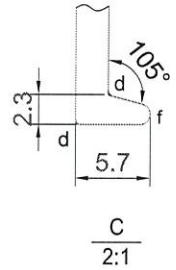
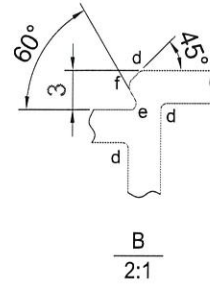
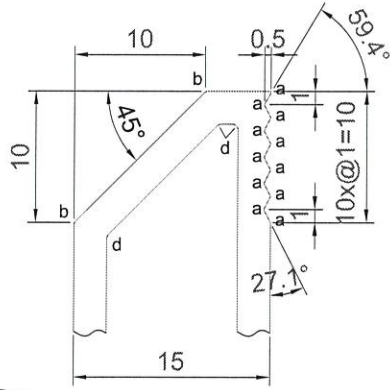

V.F

V.F

美特鋁質有限公司
 承認圖面
 日期 9-7-20

SCALE 1:2

SIGNATURE GRADEING	HIGH SIGNATURE GRADEING	C.C.DIA(MM)	131.36						
AREA (SQ MM)	1276.73	UNSPECIFIED THICKNESS	2.5	PERIMETER (MM)	485.85	STANDARD		SCALE	1:1
MASS (KG/M)	3.460	UNSPECIFIED CORNERS	-	SURFACE AREA	259.95	ALLOY	6063-T6	VERSION	
COMPANY ISSUE			DRAWA	LHR	DATE	APELATION		PAGE OF	
			STANDA-RDIZATION		DATE				
			TO SIGN		DATE				
			AUDITING		DATE				
MARKER	MODIFY	FILE NO	SIGNATURE	DATE	APPROV				

美特鋁質有限公司
 MIDI Aluminium Fabricator Ltd.

5

CUSTOMER	CUSTOMER APPROVAL	CUST PART NO.	AL-IW02T(0)
		SECTION NO.	X-13847

$a=0.1r$
 $b=0.2r$
 $c=0.3r$
 $d=0.4r$
 $e=0.5r$
 $f=0.8r$

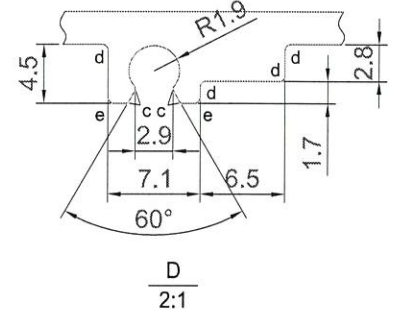
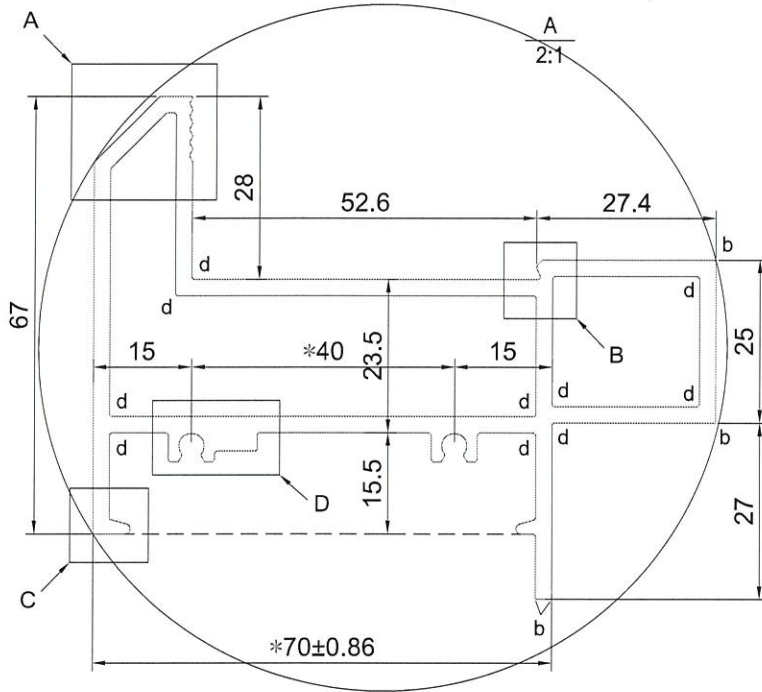
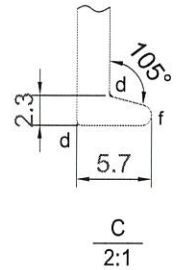
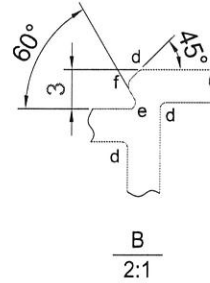
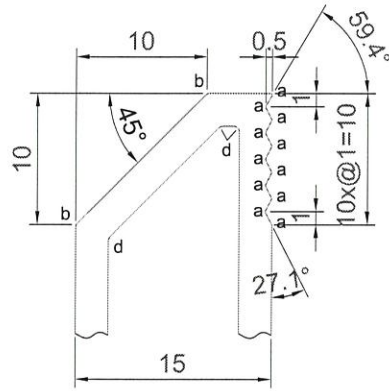

美特鋁質有限公司
 承認圖面
 日期 P-7-20

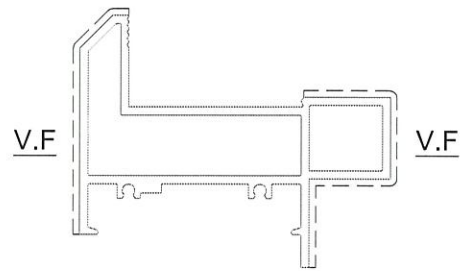

SCALE 1:2

SIGNATURE GRADEING	HIGH SIGNATURE GRADEING	C.C.DIA(MM)	105.16						
AREA (SQ MM)	914.14	UNSPECIFIED THICKNESS	2.5	PERIMETER (MM)	415.68	STANDARD		SCALE	1:1
MASS (KG/M)	2.477	UNSPECIFIED CORNERS	-	SURFACE AREA	180.04	ALLOY	6063-T6	VERSION	
COMPANY ISSUE			DRAWN	LHR	DATE	2020-02-29		PAGE OF	
			STANDARDIZATION		DATE				
			TO SIGN		DATE				
			AUDITING		DATE				
MARKER	MODIFY	FILE NO	SIGNATURE	DATE	APPROV				

美特鋁質有限公司
 MIDI Aluminium Fabricator Ltd.

CUSTOMER	CUSTOMER APPROVAL	CUST PART NO.	AL-FD01(0)
		SECTION NO.	<i>X-fs 8xf</i>

a=0.1r
b=0.2r
c=0.3r
d=0.4r
e=0.5r
f=0.8r

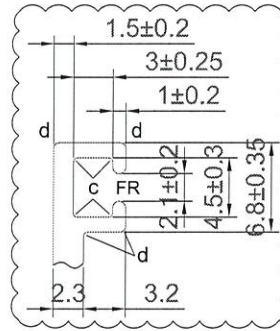

A
2:1

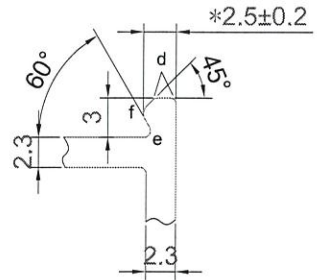

B
2:1

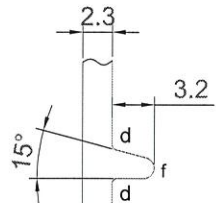

C
2:1

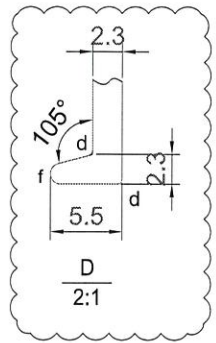

D
2:1

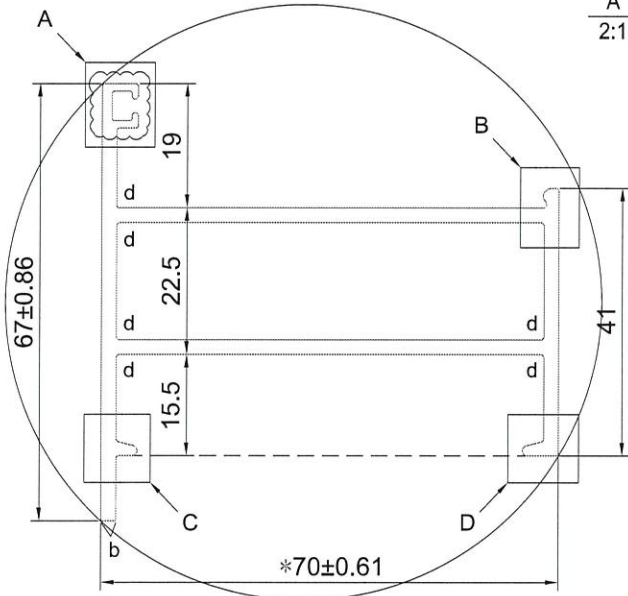

美特鋁質有限公司
承認圖面
日期 *P-7-20*

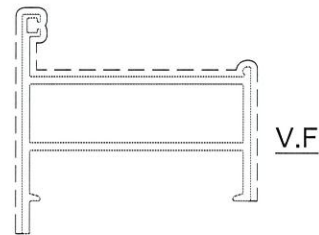

SCALE 1:2

SIGNATURE GRADEING	HIGH SIGNATURE GRADEING	C.C.DIA(MM)	91.19						
AREA (SQ MM)	566.40	UNSPECIFIED THICKNESS	2.3	PERIMETER (MM)	336.93	STANDARD		SCALE	1:1
MASS (KG/M)	1.535	UNSPECIFIED CORNERS	-	SURFACE AREA	217.04	ALLOY	6063-T6	VERSION	A
COMPANY ISSUE			DRAWA	LHR	DATE	2020-02-29	APPELLATION	PAGE OF	
			STANDA-RDIZATION		DATE		 美特鋁質有限公司 MIDI Aluminium Fabricator Ltd.		
			TO SIGN		DATE				
			AUDITING		DATE				
MARKER	MODIFY	FILE NO	SIGNATURE	DATE	APPROV	DATE			

7

CUSTOMER	CUSTOMER APPROVAL	CUST PART NO.	AL-FD01B(0)
		SECTION NO.	<i>X-8549</i>

$a=0.1r$
 $b=0.2r$
 $c=0.3r$
 $d=0.4r$
 $e=0.5r$
 $f=0.8r$

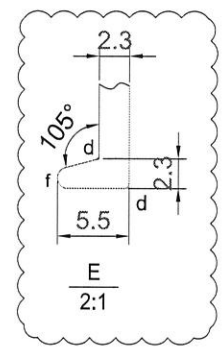
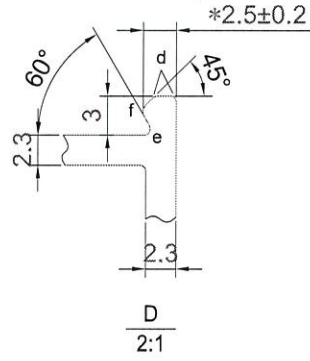
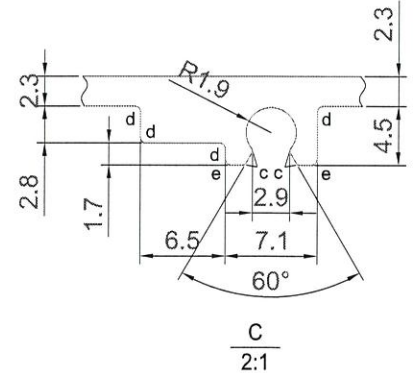
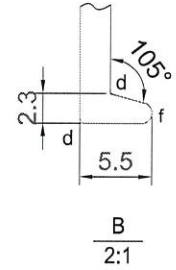
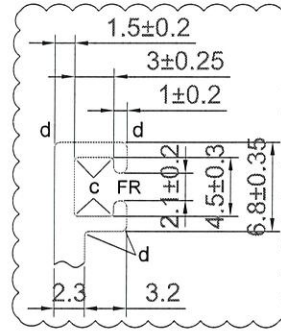
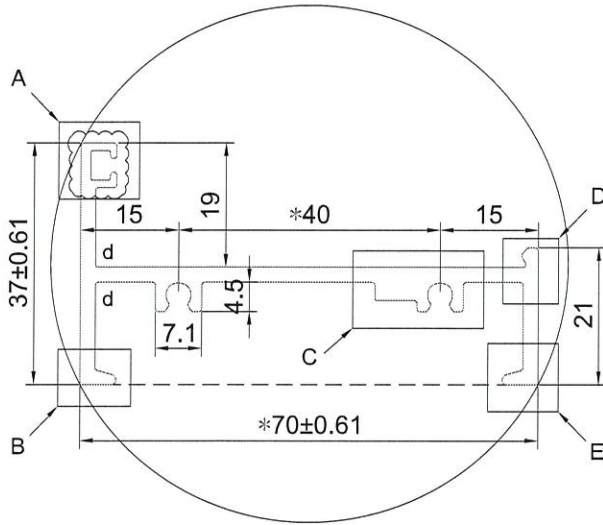

美特鋁質有限公司
 承認圖面 *[Signature]*
 日期 *P-7-20*

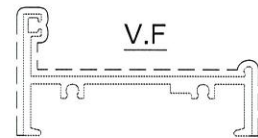

SCALE 1:2

SIGNATURE GRADEING	HIGH SIGNATURE GRADEING	C.C.DIA(MM)	79.18						
AREA (SQ MM)	353.37	UNSPECIFIED THICKNESS	2.3	PERIMETER (MM)	308.56	STANDARD		SCALE	1:1
MASS (KG/M)	0.958	UNSPECIFIED CORNERS	-	SURFACE AREA	167.16	ALLOY	6063-T6	VERSION	A
COMPANY ISSUE			DRAWN	LHR	DATE	2020-02-29	APELLATION	PAGE OF	
			STANDARDIZATION		DATE				
			TO SIGN		DATE				
			AUDITING		DATE				
MARKER	MODIFY	FILE NO	SIGNATURE	DATE	APPROV	DATE			

美特鋁質有限公司
 MIDI Aluminium Fabricator Ltd.

CUSTOMER	CUSTOMER APPROVAL	CUST PART NO.	AL-FD01M(0)
		SECTION NO.	XFS 850

$a=0.1r$
 $b=0.2r$
 $c=0.3r$
 $d=0.4r$
 $e=0.5r$
 $f=0.8r$

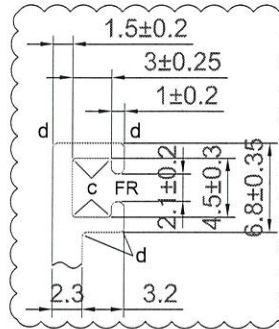

A
2:1

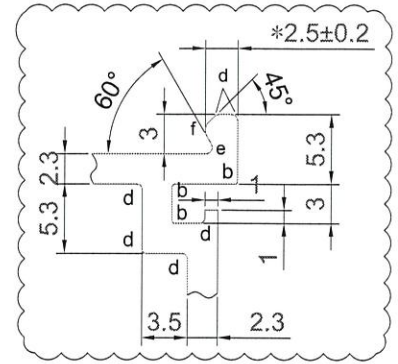

B
2:1

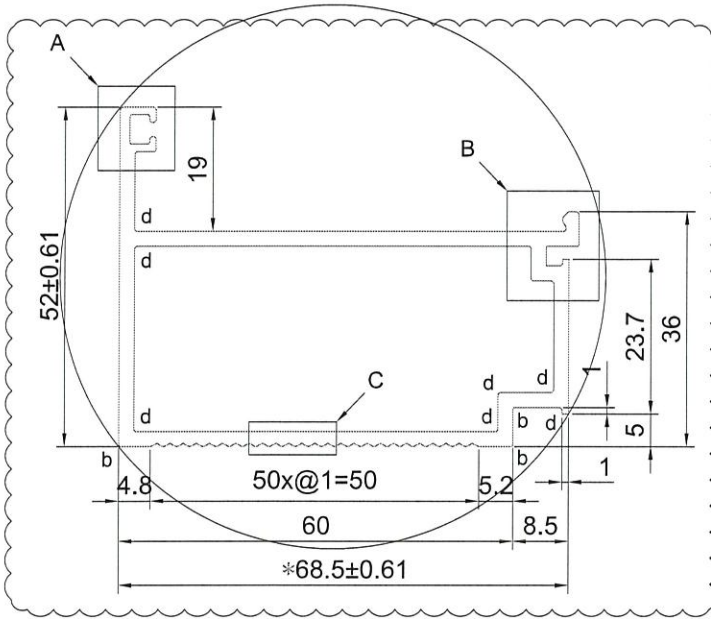

C
2:1

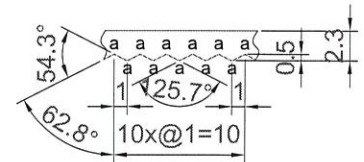

美特鋁質有限公司
 承認圖面
 日期 P-7-20

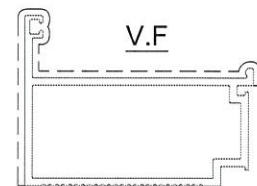
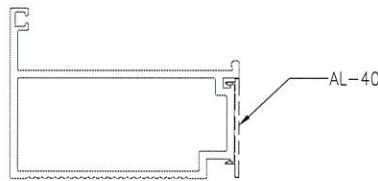

SCALE 1:2

SIGNATURE GRADEING	HIGH SIGNATURE GRADEING	C.C.DIA(MM)	83.30						
AREA (SQ MM)	503.36	UNSPECIFIED THICKNESS	2.3	PERIMETER (MM)	282.48	STANDARD		SCALE	1:1
MASS (KG/M)	1.364	UNSPECIFIED CORNERS	-	SURFACE AREA	166.34	ALLOY	6063-T6	VERSION	A
COMPANY ISSUE			DRAWA	LHR	DATE	2020-02-29	APELLATION	PAGE OF	
			STANDA-RDIZATION		DATE				
			TO SIGN		DATE				
			AUDITING		DATE				
MARKER	MODIFY	FILE NO	SIGNATURE	DATE	APPROV	DATE			

 美特鋁質有限公司
 MIDI Aluminium Fabricator Ltd.

9

CUSTOMER	CUSTOMER APPROVAL	CUST PART NO.	AL-FD01T(0)
		SECTION NO.	XJ5831

$a=0.1r$
 $b=0.2r$
 $c=0.3r$
 $d=0.4r$
 $e=0.5r$
 $f=0.8r$

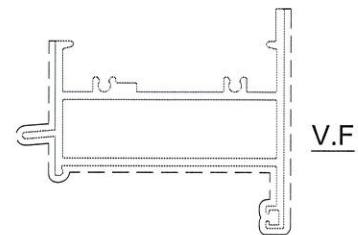
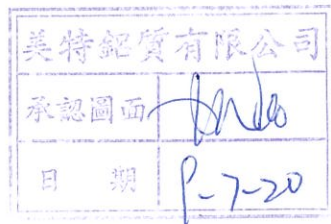
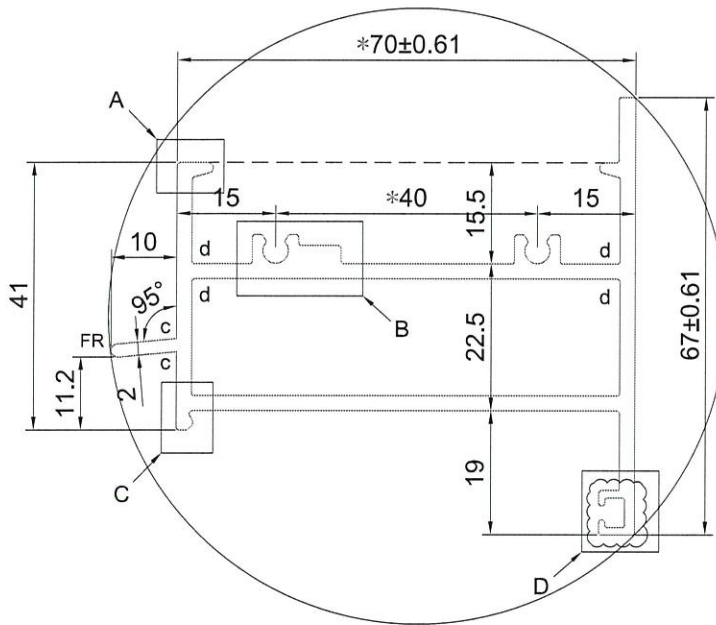
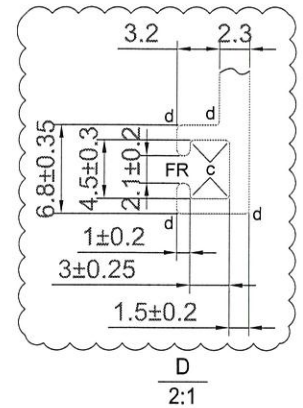
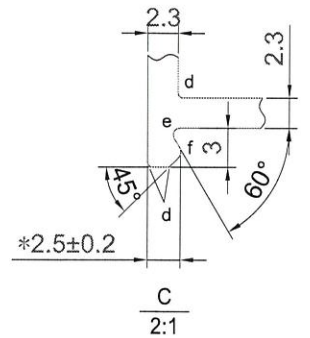
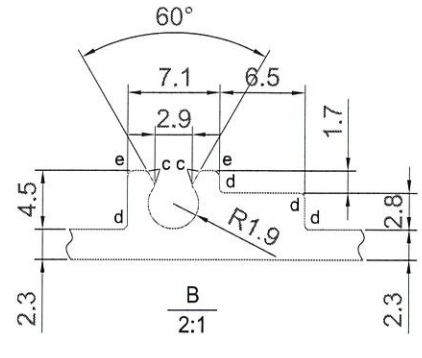
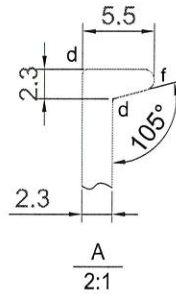

SCALE 1:2

SIGNATURE GRADEING	HIGH SIGNATURE GRADEING	C.C.DIA(MM)	94.38						
AREA (SQ MM)	640.63	UNSPECIFIED THICKNESS	2.3	PERIMETER (MM)	387.20	STANDARD		SCALE	1:1
MASS (KG/M)	1.736	UNSPECIFIED CORNERS	-	SURFACE AREA	236.25	ALLOY	6063-T6	VERSION	A
COMPANY ISSUE			DRAWA	LHR	DATE	APELATION		PAGE OF	
			STANDA-RDIZATION		DATE				
			TO SIGN		DATE				
			AUDITING		DATE				
MARKER	MODIFY	FILE NO	SIGNATURE	DATE	APPROV				

美特鋁質有限公司
 MIDI Aluminium Fabricator Ltd.

6

CUSTOMER	CUSTOMER APPROVAL	CUST PART NO.	AL-FD02(0)
		SECTION NO.	X-85776

a=0.1r
b=0.2r
c=0.3r
d=0.4r
e=0.5r
f=0.8r

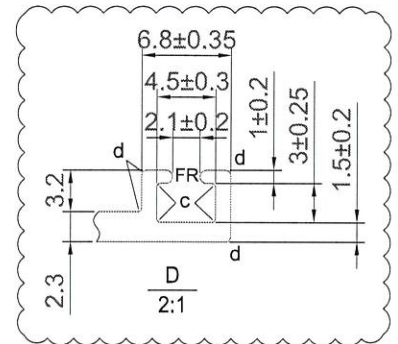
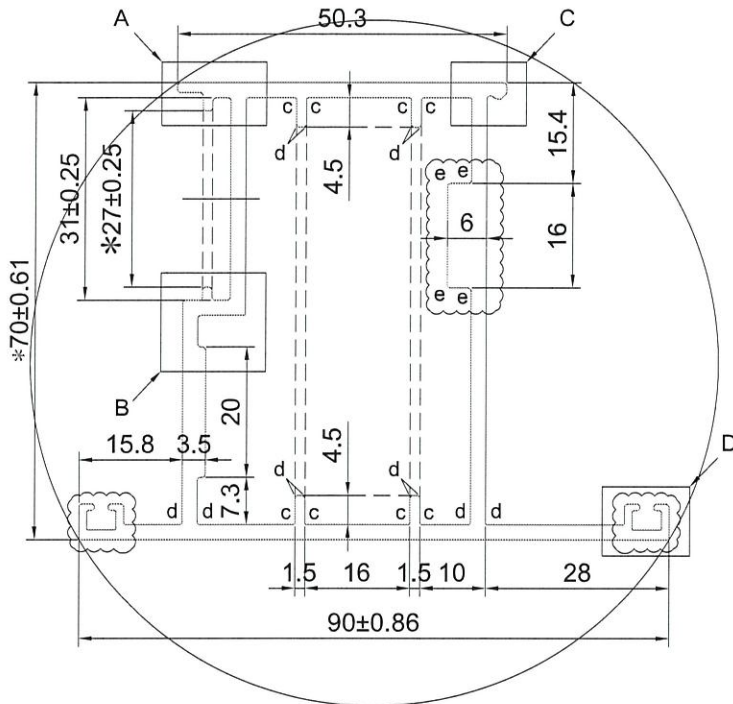
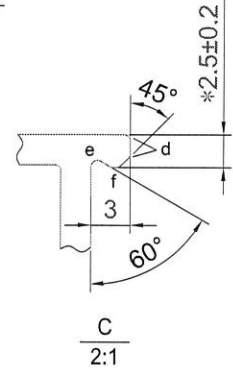
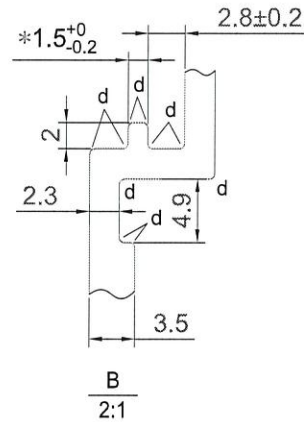
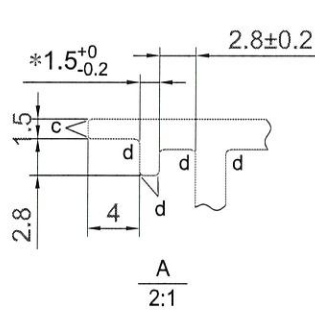

美特鋁質有限公司
承認圖面
日期 P-7-20

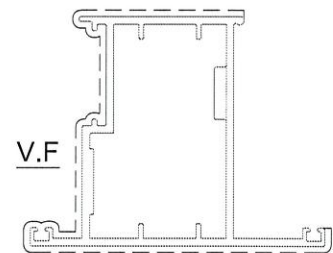
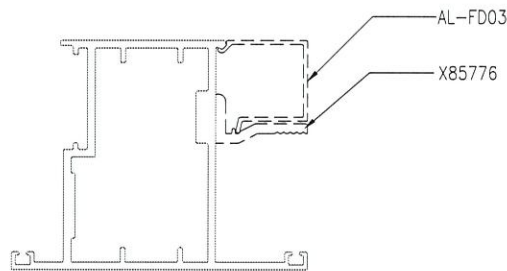

SCALE 1:2

SIGNATURE GRADEING	HIGH SIGNATURE GRADEING	C.C.DIA(MM)	105.03						
AREA (SQ MM)	764.50	UNSPECIFIED THICKNESS	2.3	PERIMETER (MM)	381.51	STANDARD		SCALE	1:1
MASS (KG/M)	2.072	UNSPECIFIED CORNERS	-	SURFACE AREA	269.61	ALLOY	6063-T6	VERSION	A
COMPANY ISSUE			DRAWA	LHR	DATE	APELATION		PAGE OF	
			STANDA-RDIZATION		DATE				
			TO SIGN		DATE				
			AUDITING		DATE				
MARKER	MODIFY	FILE NO	SIGNATURE	DATE	APPROV	DATE			

美特鋁質有限公司
MIDI Aluminium Fabricator Ltd.

CUSTOMER	CUSTOMER APPROVAL	CUST PART NO.	AL-FD03(0)
		SECTION NO.	X-88833

$a=0.1r$
 $b=0.2r$
 $c=0.3r$
 $d=0.4r$
 $e=0.5r$
 $f=0.8r$

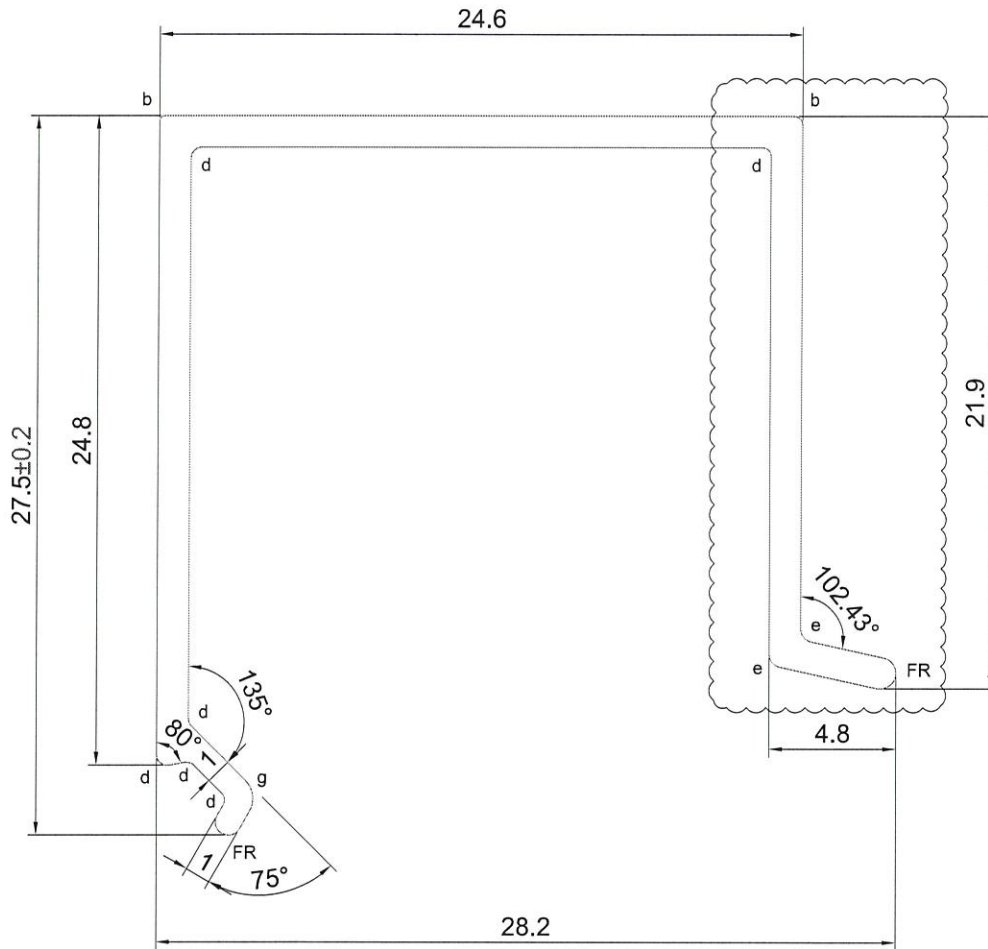

SCALE 4:1

美特鋁質有限公司
承認圖面
日期 8-7-20

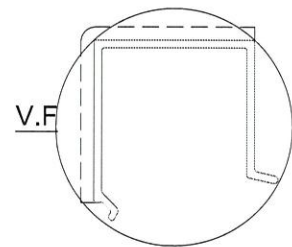

SIGNATURE GRADEING	HIGH SIGNATURE GRADEING	C.C.DIA(MM)	36.22						
AREA (SQ MM)	90.46	UNSPECIFIED THICKNESS	1.2	PERIMETER (MM)	152.49	STANDARD		SCALE	1:1
MASS (KG/M)	0.245	UNSPECIFIED CORNERS	-	SURFACE AREA	49.83	ALLOY	6063-T5	VERSION	A
COMPANY ISSUE			DRAWN	LHR	DATE	2020-02-29	APELLATION	PAGE OF	
			STANDARDIZATION		DATE		<p>美特鋁質有限公司 MIDI Aluminium Fabricator Ltd.</p>		
			TO SIGN		DATE				
			AUDITING		DATE				
MARKER	MODIFY	FILE NO	SIGNATURE	DATE	APPROV	DATE			

12

CUSTOMER	CUSTOMER APPROVAL	CUST PART NO.	AL-40(0)
		SECTION NO.	XDS 854

$a=0.1r$
 $b=0.2r$
 $c=0.3r$
 $d=0.4r$
 $e=0.5r$
 $f=0.8r$

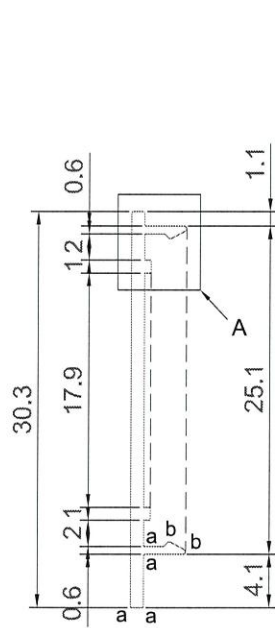

SCALE 2:1

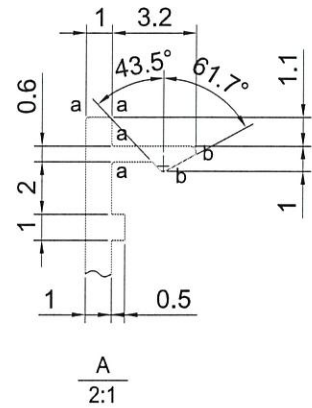

A
2:1

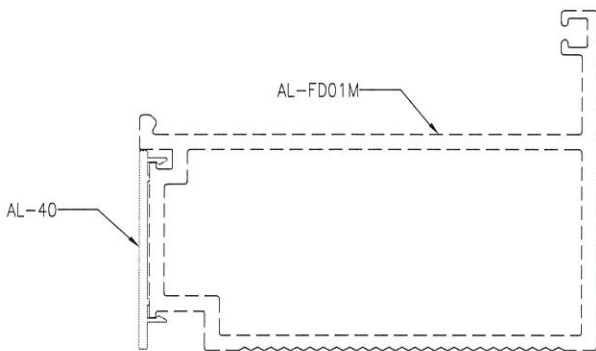

SCALE 1:1

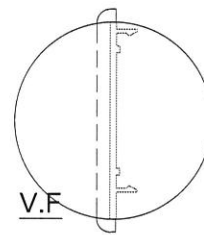
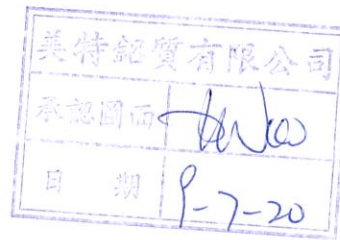

SCALE 1:1

SIGNATURE GRADEING	HIGH SIGNATURE GRADEING	C.C.DIA(MM)	30.12						
AREA (SQ MM)	40.63	UNSPECIFIED THICKNESS	1.0	PERIMETER (MM)	75.34	STANDARD		SCALE	1:1
MASS (KG/M)	0.065	UNSPECIFIED CORNERS	-	SURFACE AREA	32.22	ALLOY	6063-T5	VERSION	
COMPANY ISSUE			DRAWA	LHR	DATE	2020-06-17	APELLATION	PAGE OF	
			STANDA-RDIZATION		DATE				
			TO SIGN		DATE				
			AUDITING		DATE				
MARKER	MODIFY	FILE NO	SIGNATURE	DATE	APPROV				

美特鋁質有限公司
 MIDI Aluminium Fabricator Ltd.

CUSTOMER	CUSTOMER APPROVAL	CUST PART NO.	AL-DS01T(0)
		SECTION NO.	<i>xj8886</i>

$a=0.1r$
 $b=0.2r$
 $c=0.3r$
 $d=0.4r$
 $e=0.5r$
 $f=0.8r$

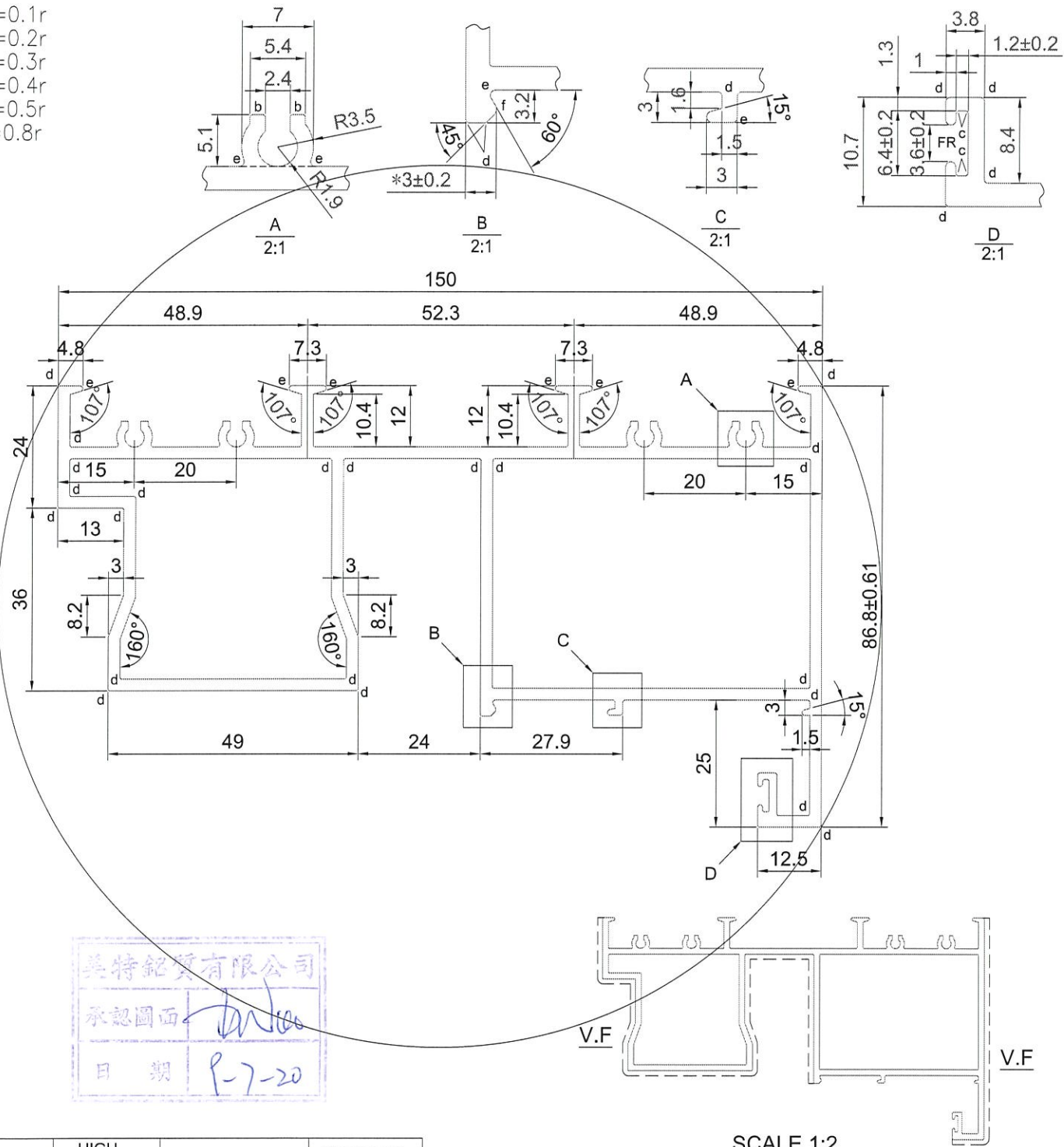

美特鋁質有限公司
 承認圖面
 日期 P-7-20

SCALE 1:2

SIGNATURE GRADEING	HIGH SIGNATURE GRADEING	C.C.DIA(MM)	173.31						
AREA (SQ MM)	1368.75	UNSPECIFIED THICKNESS	2.3	PERIMETER (MM)	802.93	STANDARD		SCALE	1:1
MASS (KG/M)	3.709	UNSPECIFIED CORNERS	-	SURFACE AREA	345.46	ALLOY	6063-T6	VERSION	
COMPANY ISSUE			DRAWA	LHR	DATE	APELLATION		PAGE OF	
			STANDA-RDIZATION		DATE				
			TO SIGN		DATE				
			AUDITING		DATE				
MARKER MODIFY	FILE NO	SIGNATURE	DATE	APPROV	DATE				

美特鋁質有限公司
 MIDI Aluminium Fabricator Ltd.

18

CUSTOMER	CUSTOMER APPROVAL	CUST PART NO.	AL-DS01B(0)
		SECTION NO.	185857

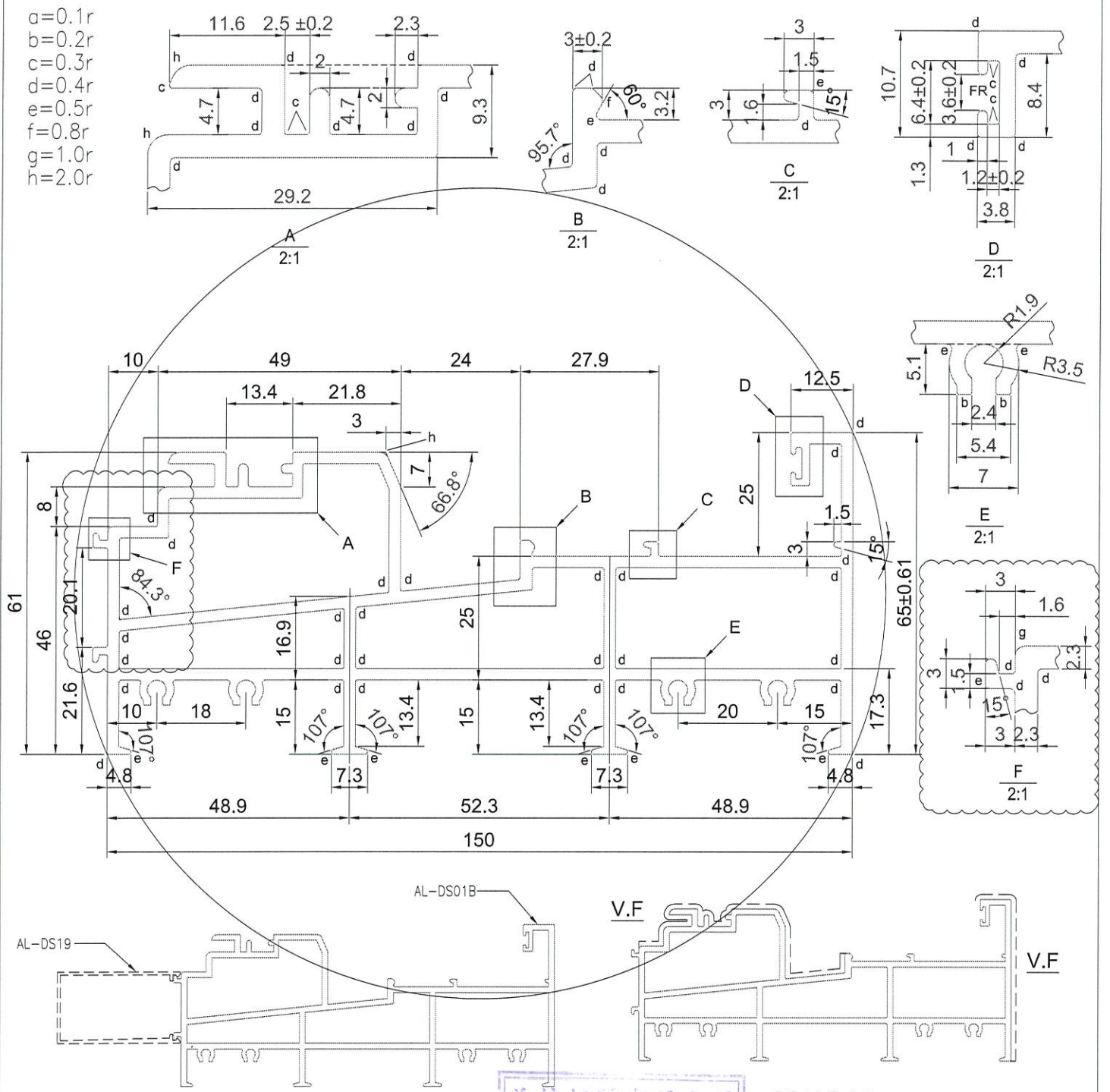

美特鋁質有限公司
承認圖面

SCALE 1:2

SIGNATURE GRADEING	HIGH SIGNATURE GRADEING	C.C.DIA(MM)	163.48						
AREA (SQ.MM)	1508.81	UNSPECIFIED THICKNESS	2.3	PERIMETER (MM)	787.31	STANDARD	SCALE	1:1	
MASS (KG/M)	4.089	UNSPECIFIED CORNERS	-	SURFACE AREA	251.12	ALLOY	6063-T6	VERSION	A
COMPANY ISSUE			DRAWN	LHR	DATE	2020-02-29	APELLATION	PAGE OF	
			STANDARDIZATION		DATE				
			TO SIGN		DATE				
			AUDITING		DATE				
MARKER	MODIFY	FILE NO	SIGNATURE	DATE	APPROV	DATE			

美特鋁質有限公司
MIDI Aluminium Fabricator Ltd.

CUSTOMER	CUSTOMER APPROVAL	CUST PART NO.	AL-DS02T(0)
		SECTION NO.	XP8859

a=0.1r
b=0.2r
c=0.3r
d=0.4r
e=0.5r
f=0.8r

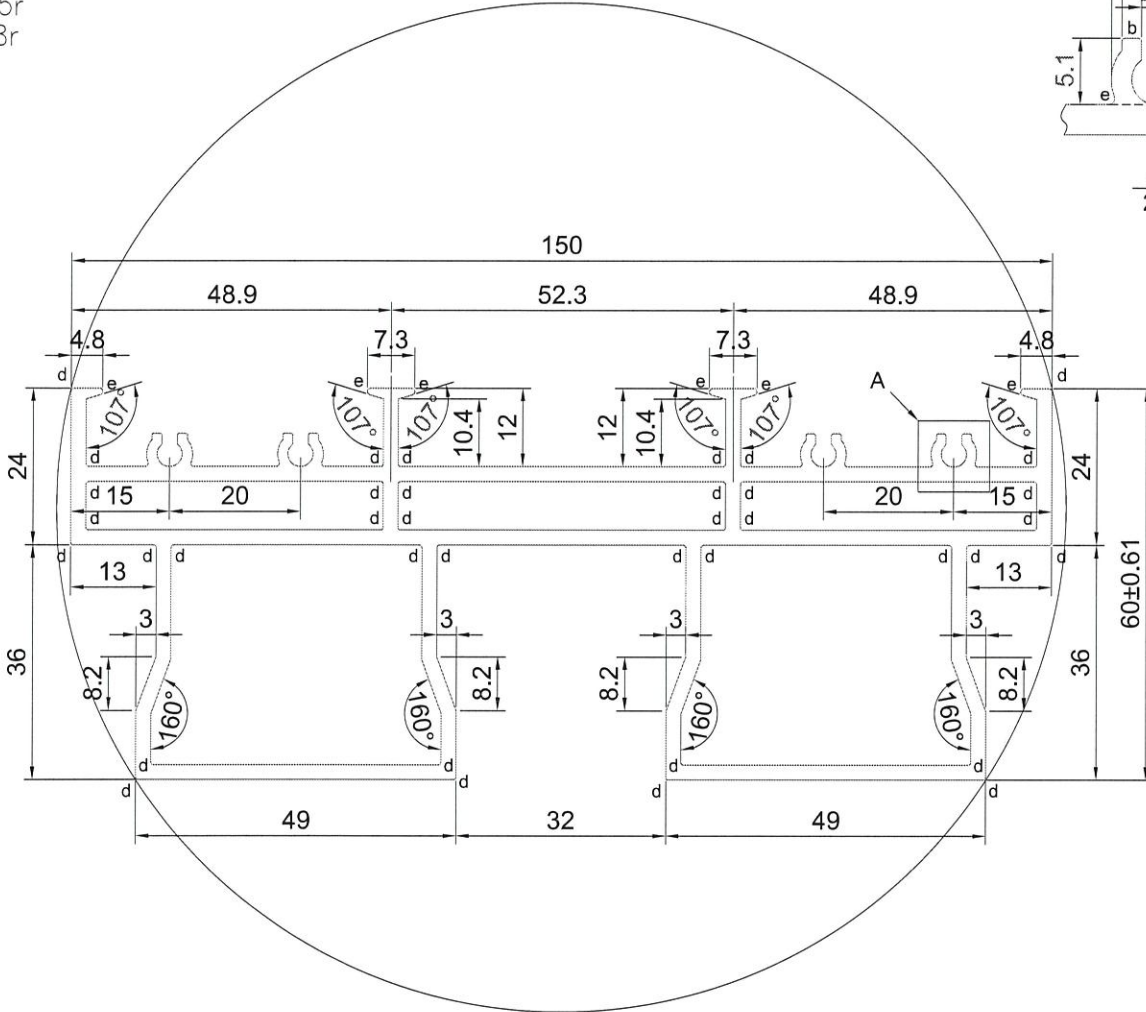
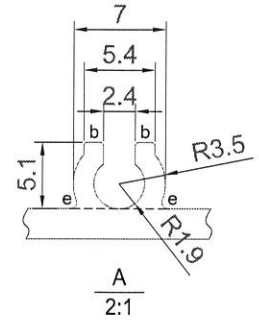

美特鋁質有限公司
承認圖面
日期 9-7-20

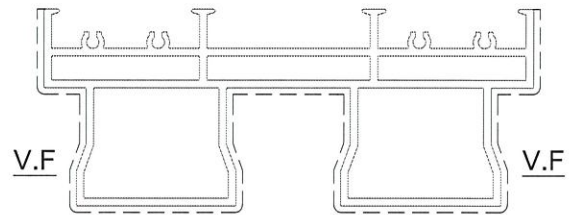

SCALE 1:2

SIGNATURE GRADEING	HIGH SIGNATURE GRADEING	C.C.DIA(MM)	154.42						
AREA (SQ MM)	1497.98	UNSPECIFIED THICKNESS	2.3	PERIMETER (MM)	675.64	STANDARD		SCALE	1:1
MASS (KG/M)	4.059	UNSPECIFIED CORNERS	-	SURFACE AREA	354.86	ALLOY	6063-T6	VERSION	
COMPANY ISSUE			DRAWN	LHR	DATE	2020-02-29	APPELLATION	PAGE OF	
			STANDARDIZATION		DATE				
			TO SIGN		DATE				
			AUDITING		DATE				
MARKER	MODIFY	FILE NO	SIGNATURE	DATE	APPROV				

美特鋁質有限公司
MIDI Aluminium Fabricator Ltd.

18

CUSTOMER	CUSTOMER APPROVAL	CUST PART NO.	AL-DS02B(0)
		SECTION NO.	X85860

$a=0.1r$
 $b=0.2r$
 $c=0.3r$
 $d=0.4r$
 $e=0.5r$
 $f=0.8r$
 $g=1.0r$
 $h=2.0r$

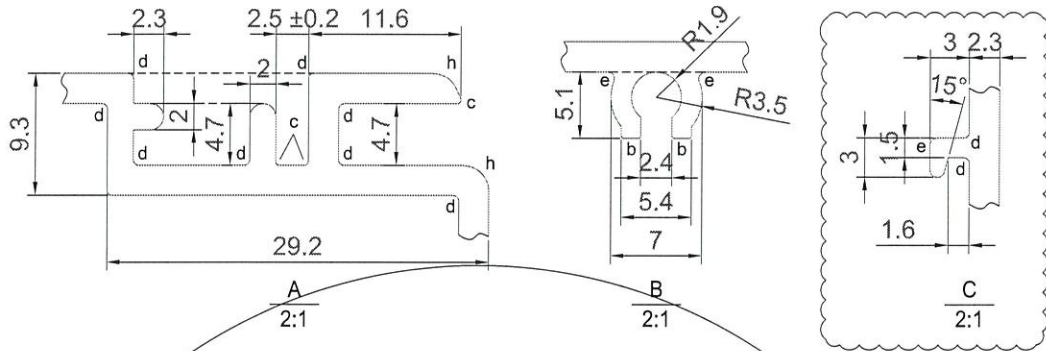

美特鋁質有限公司
 承認圖章
 日期 8-7-20

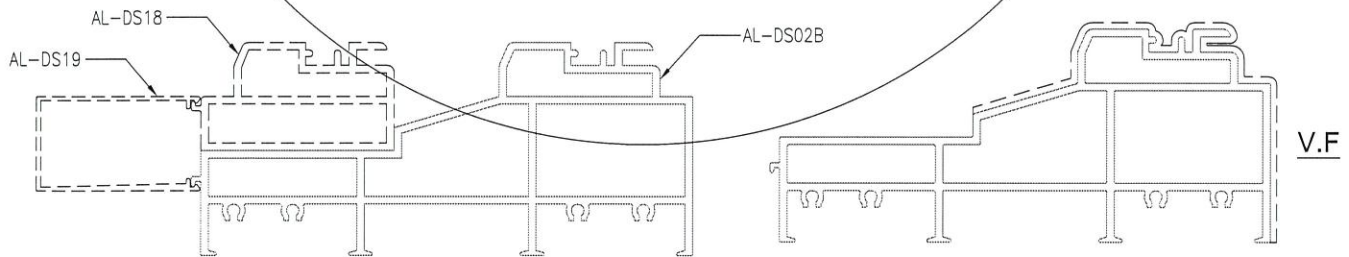
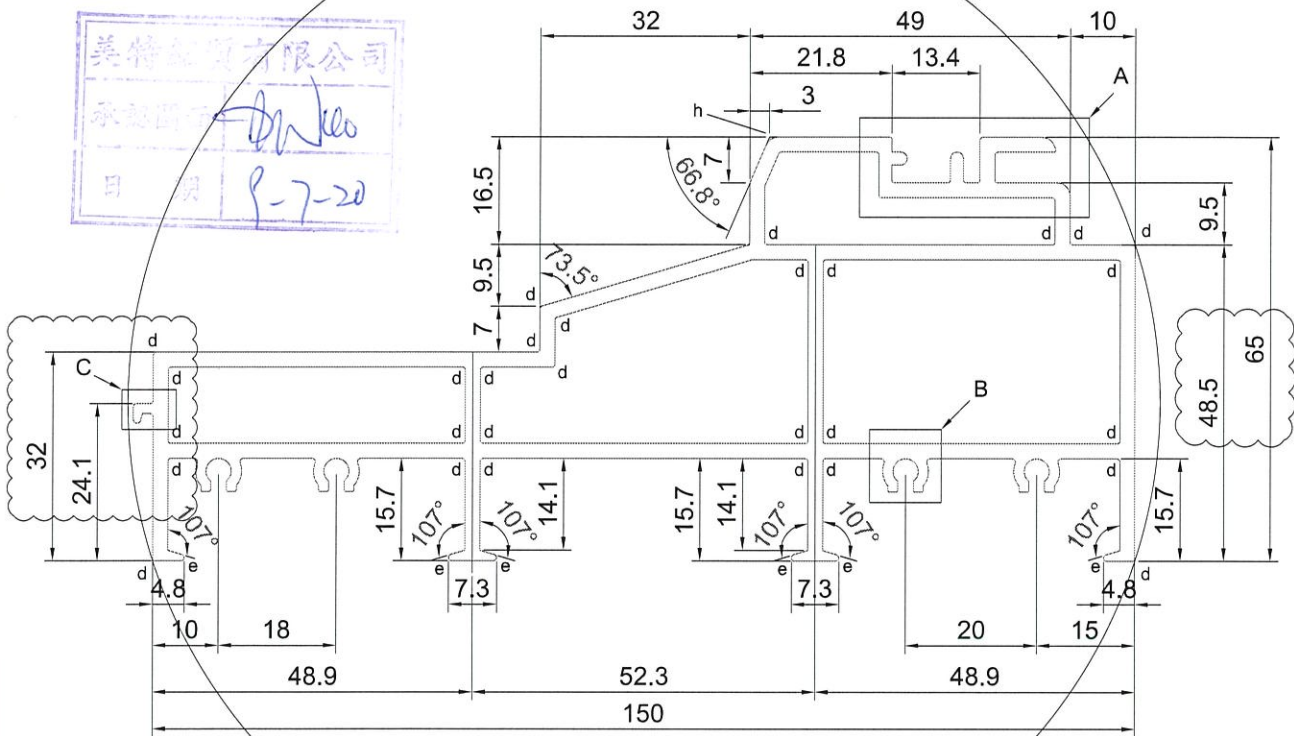

SCALE 1:2

SIGNATURE GRADEING	HIGH SIGNATURE GRADEING	C.C.DIA(MM)	157.65						
AREA (SQ MM)	1352.77	UNSPECIFIED THICKNESS	2.3	PERIMETER (MM)	661.08	STANDARD		SCALE	1:1
MASS (KG/M)	3.666	UNSPECIFIED CORNERS	-	SURFACE AREA	212.79	ALLOY	6063-T6	VERSION	A
COMPANY ISSUE			DRAWN	LHR	DATE	2020-02-29	APPELLATION	PAGE OF	
			STANDARDIZATION		DATE				
			TO SIGN		DATE				
			AUDITING		DATE				
MARKER	MODIFY	FILE NO	SIGNATURE	DATE	APPROV	DATE			

 美特鋁質有限公司
 MIDI Aluminium Fabricator Ltd.

19

CUSTOMER	CUSTOMER APPROVAL	CUST PART NO.	AL-DS03(0)
		SECTION NO.	285861

a=0.1r
b=0.2r
c=0.3r
d=0.4r
e=0.5r
f=0.8r

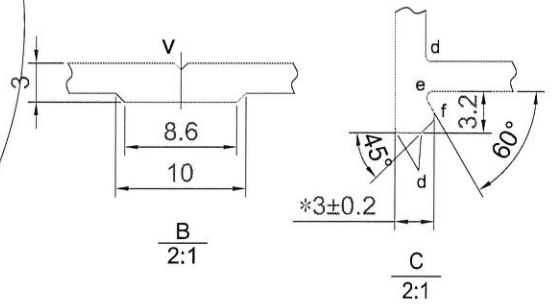
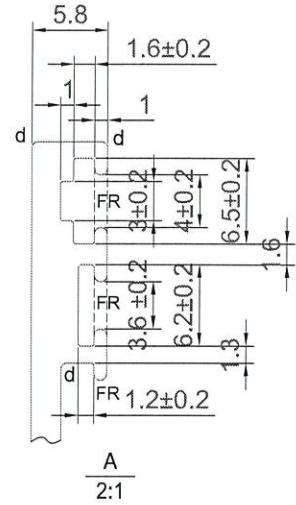
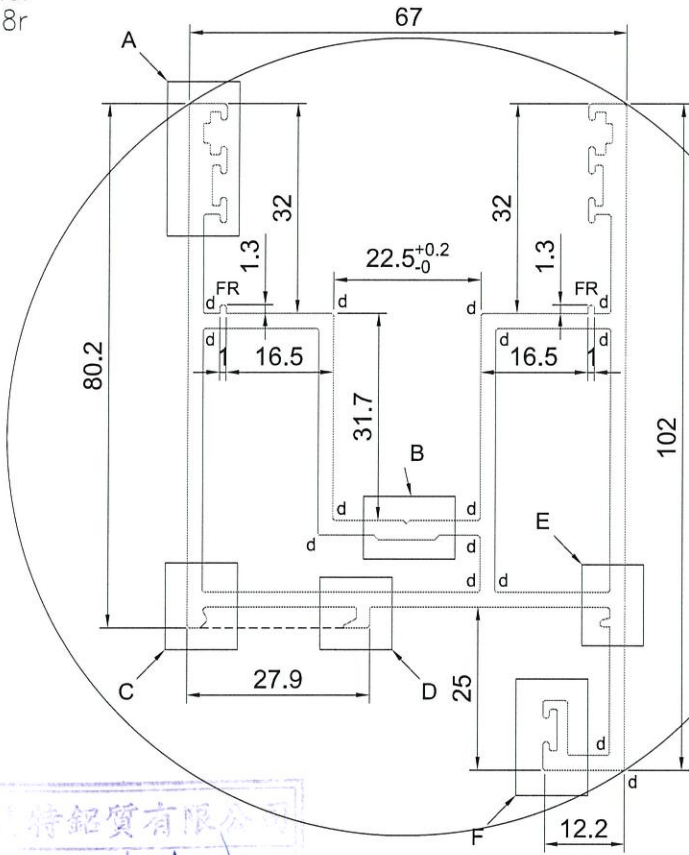

特鋁質有限公司
承認圖面
日期 P-7-20

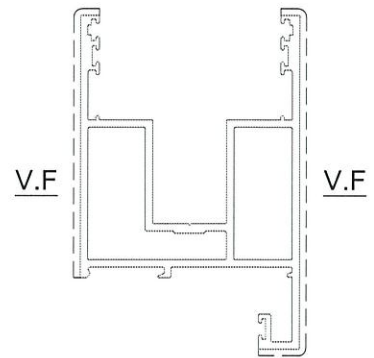
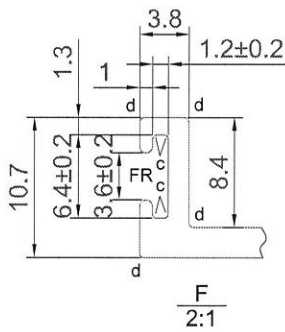
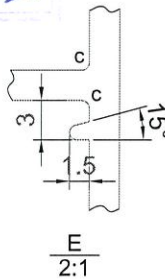
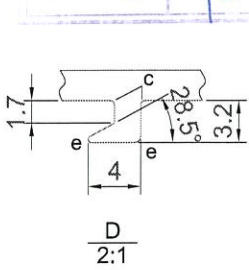

SCALE 1:2

SIGNATURE GRADEING	HIGH SIGNATURE GRADEING	C.C.DIA(MM)	122.04						
AREA (SQ MM)	998.65	UNSPECIFIED THICKNESS	2.3	PERIMETER (MM)	585.82	STANDARD		SCALE	1:1
MASS (KG/M)	2.706	UNSPECIFIED CORNERS	0.2	SURFACE AREA	206.87	ALLOY	6063-T6	VERSION	
COMPANY ISSUE			DRAWN	LHR	DATE	2020-02-29	APPELLATION	PAGE OF	
			STANDARDIZATION		DATE				
			TO SIGN		DATE				
			AUDITING		DATE				
MARKER	MODIFY	FILE NO	SIGNATURE	DATE	APPROV				

美特鋁質有限公司
MIDI Aluminium Fabricator Ltd.

CUSTOMER	CUSTOMER APPROVAL	CUST PART NO.	AL-DS04(0)
		SECTION NO.	<i>2886</i>

$a=0.1r$
 $b=0.2r$
 $c=0.3r$
 $d=0.4r$
 $e=0.5r$
 $f=0.8r$
 $g=1.0r$

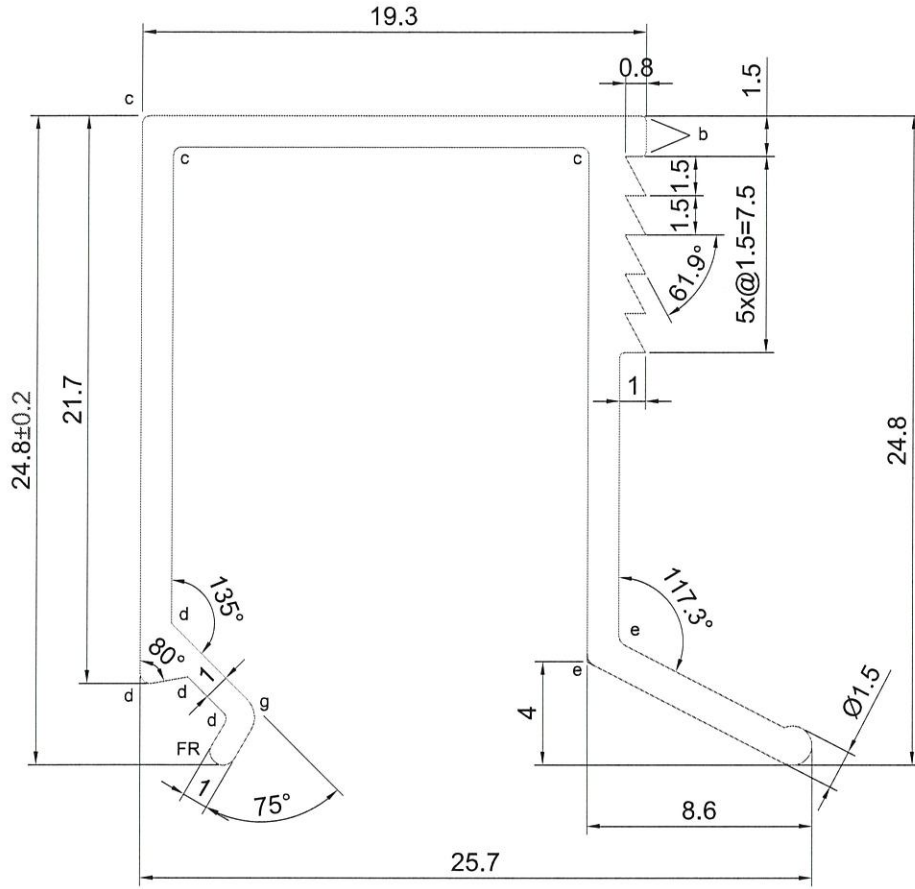

SCALE 4:1

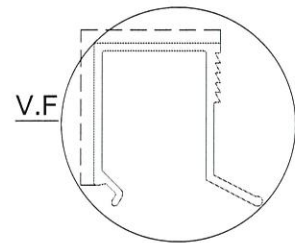
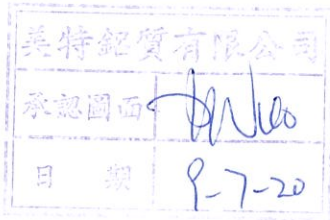

SCALE 1:1

SIGNATURE GRADEING	HIGH SIGNATURE GRADEING	C.C.DIA(MM)	35.75						
AREA (SQ MM)	92.73	UNSPECIFIED THICKNESS	1.2	PERIMETER (MM)	152.08	STANDARD		SCALE	1:1
MASS (KG/M)	0.251	UNSPECIFIED CORNERS	-	SURFACE AREA	41.31	ALLOY	6063-T5	VERSION	
COMPANY ISSUE			DRAWN	LHR	DATE	2020-02-29	APPELLATION	PAGE OF	
			STANDARDIZATION		DATE				
			TO SIGN		DATE				
			AUDITING		DATE				
MARKER	MODIFY	FILE NO	SIGNATURE	DATE	APPROV	DATE			

美特鋁質有限公司
 MIDI Aluminium Fabricator Ltd.

21

CUSTOMER	CUSTOMER APPROVAL	CUST PART NO.	AL-DS05(0)
		SECTION NO.	25803

a=0.1r
b=0.2r
c=0.3r
d=0.4r
e=0.5r
f=0.8r

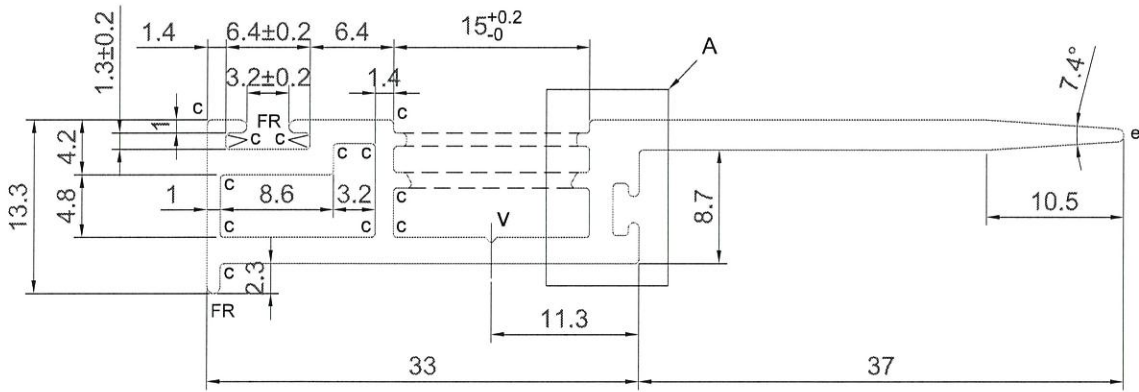
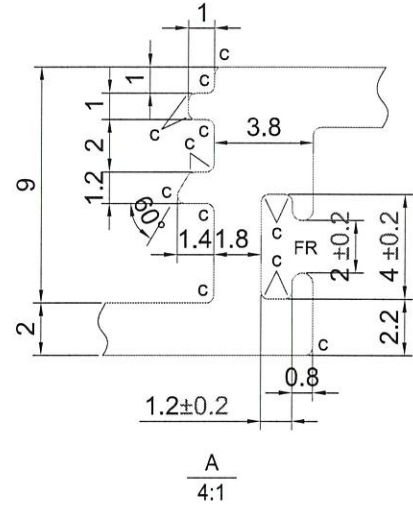

SCALE 2:1

美特鋁質有限公司	
承認圖面	<i>[Signature]</i>
日期	P-7-20

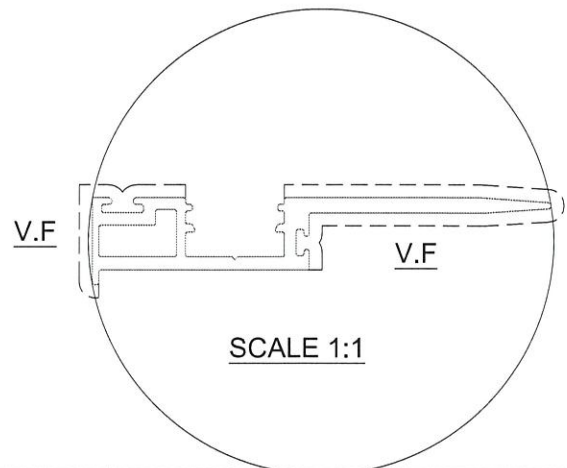

SCALE 1:1

SIGNATURE GRADEING	HIGH SIGNATURE GRADEING	C.C.DIA(MM)	71.06						
AREA (SQ MM)	230.79	UNSPECIFIED THICKNESS	2.3	PERIMETER (MM)	205.29	STANDARD		SCALE	1:1
MASS (KG/M)	0.625	UNSPECIFIED CORNERS	-	SURFACE AREA	132.53	ALLOY	6063-T6	VERSION	
COMPANY ISSUE			DRAWN	LHR	DATE	2020-02-29	APPELLATION	PAGE OF	
			STANDARDIZATION		DATE				
			TO SIGN		DATE				
			AUDITING		DATE				
MARKER	MODIFY	FILE NO	SIGNATURE	DATE	APPROV	DATE			

美特鋁質有限公司
MIDI Aluminium Fabricator Ltd.

22

CUSTOMER	CUSTOMER APPROVAL	CUST PART NO.	AL-DS05S(0)
		SECTION NO.	288864

$a=0.1r$
 $b=0.2r$
 $c=0.3r$
 $d=0.4r$
 $e=0.5r$
 $f=0.8r$
 $g=1.0r$
 $j=1.5r$
 $h=2.0r$

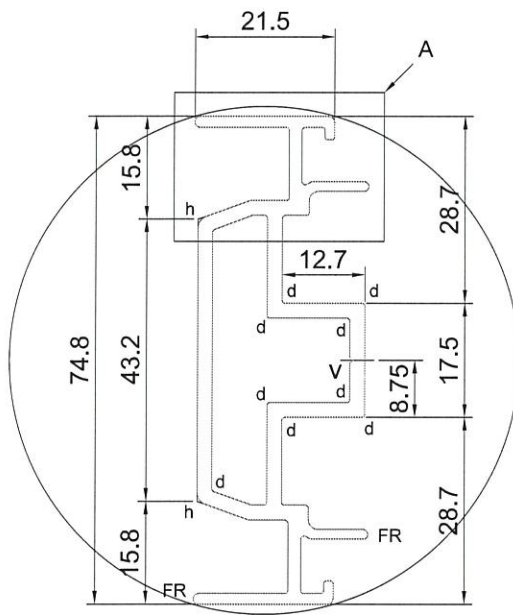
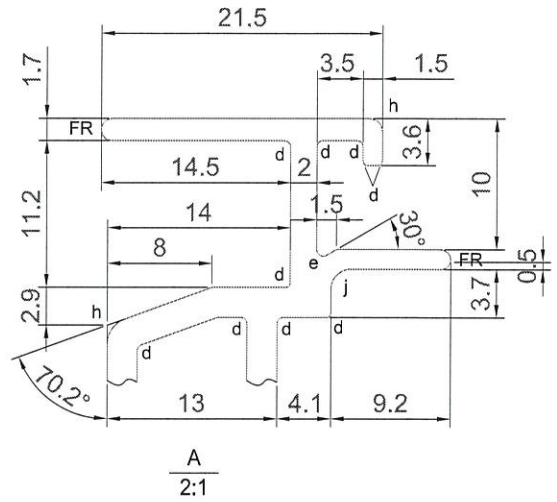

美特鋁質有限公司
 承認圖面
 日期 1-7-20

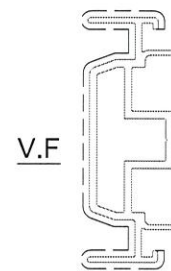

SCALE 1:2

SIGNATURE GRADEING	HIGH SIGNATURE GRADEING	C.C.DIA(MM)	77.83						
AREA (SQ MM)	486.88	UNSPECIFIED THICKNESS	2.3	PERIMETER (MM)	326.53	STANDARD		SCALE	1:1
MASS (KG/M)	1.319	UNSPECIFIED CORNERS	-	SURFACE AREA	173.88	ALLOY	6063-T6	VERSION	
COMPANY ISSUE		DRAWN	LHR	DATE	2020-02-29	APELLATION	PAGE OF		
		STANDARDIZATION		DATE					
		TO SIGN		DATE					
		AUDITING		DATE					
MARKER	MODIFY	FILE NO	SIGNATURE	DATE	APPROV	DATE			

美特鋁質有限公司
 MIDI Aluminium Fabricator Ltd.

27

CUSTOMER	CUSTOMER APPROVAL	CUST PART NO.	AL-DS06(0)
		SECTION NO.	x 85865

a=0.1r
b=0.2r
c=0.3r
d=0.4r
e=0.5r
f=0.8r

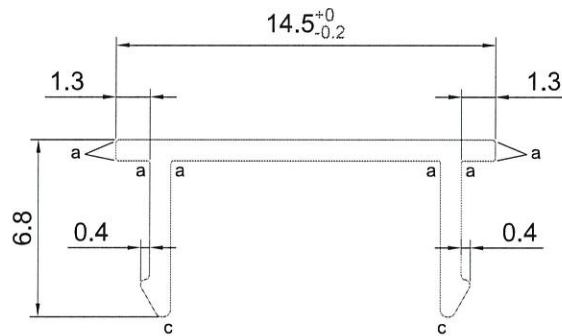

SCALE 4:1

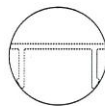

SCALE 1:1

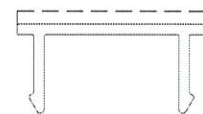

SCALE 2:1

SIGNATURE GRADEING	HIGH SIGNATURE GRADEING	C.C.DIA(MM)	14.96						
AREA (SQ MM)	21.32	UNSPECIFIED THICKNESS	0.8	PERIMETER (MM)	53.90	STANDARD		SCALE	1:1
MASS (KG/M)	0.058	UNSPECIFIED CORNERS	-	SURFACE AREA	14.60	ALLOY	6063-T5	VERSION	
COMPANY ISSUE		DRAWA	LHR	DATE	2020-02-29	APELLATION	PAGE OF		
		STANDA-RDIZATION		DATE					
		TO SIGN		DATE					
		AUDITING		DATE					
MARKER	MODIFY	FILE NO	SIGNATURE	DATE	APPROV	DATE			

美特鋁質有限公司
MIDI Aluminium Fabricator Ltd.

CUSTOMER	CUSTOMER APPROVAL	CUST PART NO.	AL-DS07(0)
		SECTION NO.	805866

$a=0.1r$
 $b=0.2r$
 $c=0.3r$
 $d=0.4r$
 $e=0.5r$
 $f=0.8r$

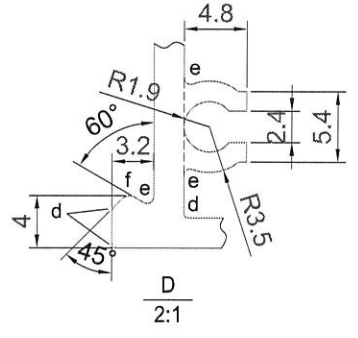
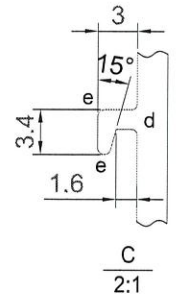
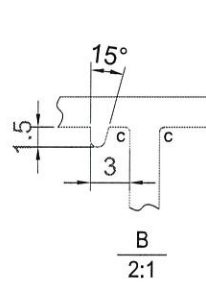
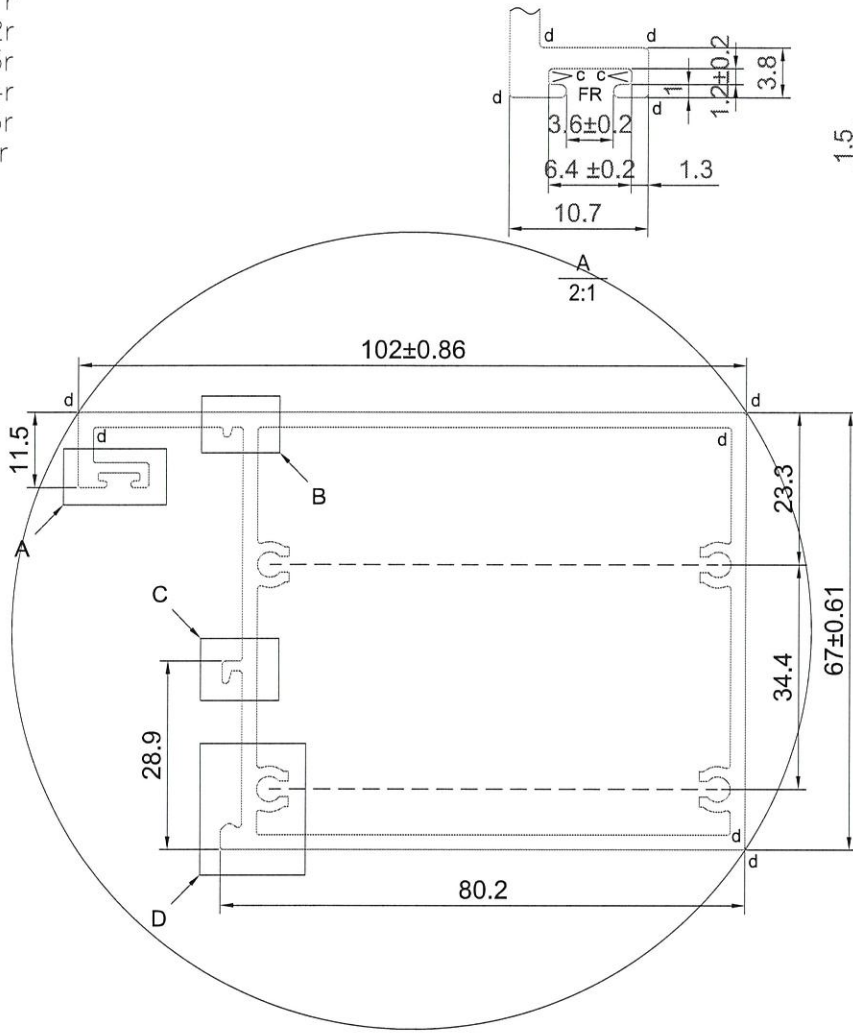

美特鋁質有限公司
 承認圖面
 日期: P-7-20

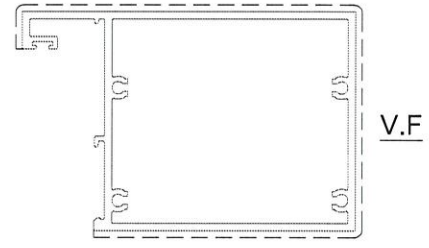

SCALE 1:2

SIGNATURE GRADEING	HIGH SIGNATURE GRADEING	C.C.DIA(MM)	122.04						
AREA (SQ MM)	827.12	UNSPECIFIED THICKNESS	2.3	PERIMETER (MM)	396.94	STANDARD		SCALE	1:1
MASS (KG/M)	2.241	UNSPECIFIED CORNERS	-	SURFACE AREA	260.41	ALLOY	6063-T6	VERSION	
COMPANY ISSUE			DRAWN	LHR	DATE	2020-02-29	APELLATION	PAGE OF	
			STANDARDIZATION		DATE				
			TO SIGN		DATE				
			AUDITING		DATE				
MARKER	MODIFY	FILE NO	SIGNATURE	DATE	APPROV	DATE			

美特鋁質有限公司
 MIDI Aluminium Fabricator Ltd.
 25

CUSTOMER	CUSTOMER APPROVAL	CUST PART NO.	AL-DS08(0)
		SECTION NO.	8-858(7)

$a=0.1r$
 $b=0.2r$
 $c=0.3r$
 $d=0.4r$
 $e=0.5r$
 $f=0.8r$

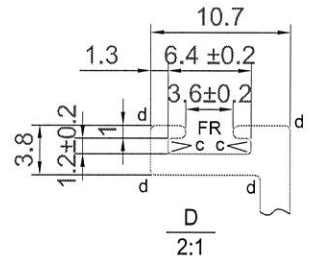
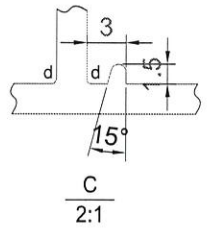
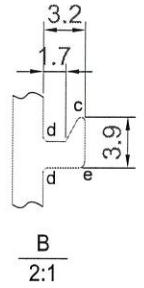
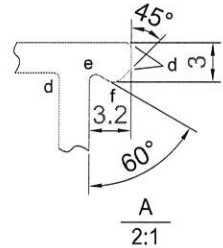
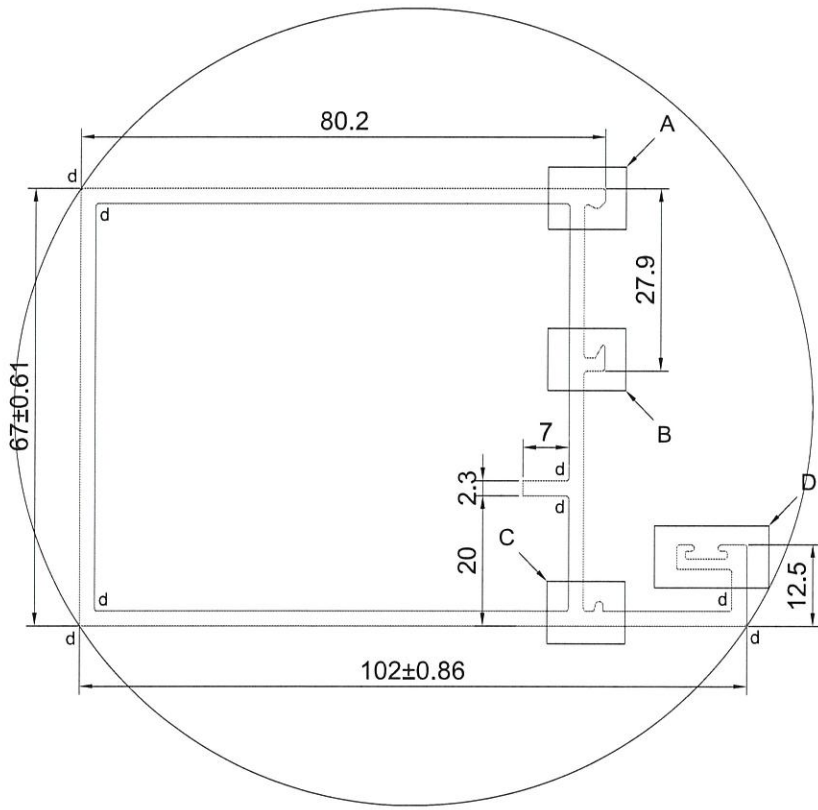

美特鋁質有限公司
 承認圖面
 日期 1-7-20

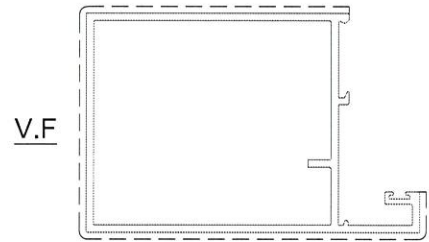

SCALE 1:2

SIGNATURE GRADEING	HIGH SIGNATURE GRADEING	C.C.DIA(MM)	122.04						
AREA (SQ MM)	777.36	UNSPECIFIED THICKNESS	2.3	PERIMETER (MM)	399.50	STANDARD		SCALE	1:1
MASS (KG/M)	2.107	UNSPECIFIED CORNERS	-	SURFACE AREA	261.64	ALLOY	6063-T6	VERSION	
COMPANY ISSUE		DRAWN	LHR	DATE	2020-02-29	APPELLATION		PAGE OF	
		STANDARDIZATION		DATE					
		TO SIGN		DATE					
		AUDITING		DATE					
MARKER	MODIFY	FILE NO	SIGNATURE	DATE	APPROV				

 美特鋁質有限公司
 MIDI Aluminium Fabricator Ltd.

26

CUSTOMER	CUSTOMER APPROVAL	CUST PART NO.	AL-DS09(0)
		SECTION NO.	285868

$a=0.1r$
 $b=0.2r$
 $c=0.3r$
 $d=0.4r$
 $e=0.5r$
 $f=0.8r$

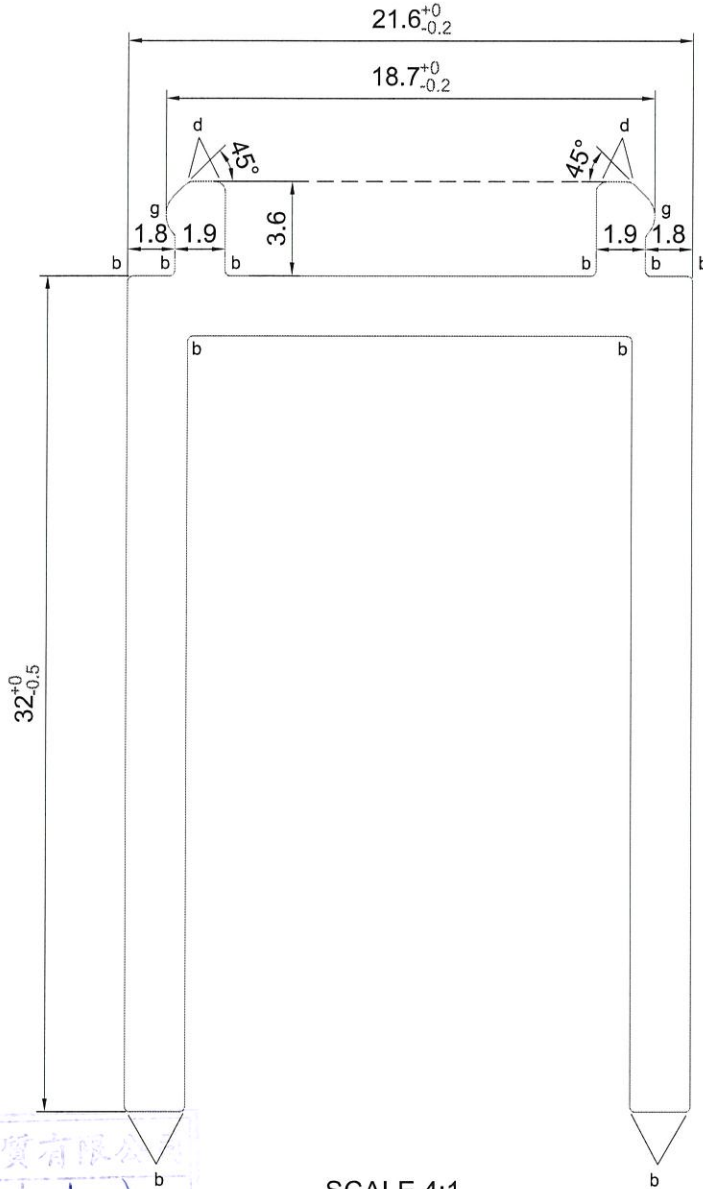

美特鋁質有限公司
 承認圖面
 日期 9-7-20

SCALE 4:1

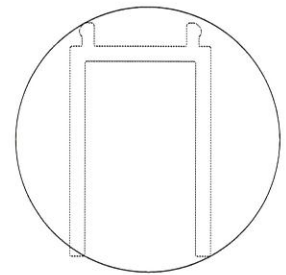

SCALE 1:1

SIGNATURE GRADEING	HIGH SIGNATURE GRADEING	C.C.DIA(MM)	40.50						
AREA (SQ MM)	200.39	UNSPECIFIED THICKNESS	2.3	PERIMETER (MM)	179.37	STANDARD		SCALE	1:1
MASS (KG/M)	0.543	UNSPECIFIED CORNERS	-	SURFACE AREA	-	ALLOY	6063-T6	VERSION	
COMPANY ISSUE		DRAWN	LHR	DATE	2020-02-29	APPELLATION		PAGE OF	
		STANDARDIZATION		DATE		 美特鋁質有限公司 MIDI Aluminium Fabricator Ltd.			
		TO SIGN		DATE					
		AUDITING		DATE					
MARKER	MODIFY	FILE NO	SIGNATURE	DATE	APPROV	DATE			

27

CUSTOMER	CUSTOMER APPROVAL	CUST PART NO.	AL-DS10(0)
		SECTION NO.	X 85869

a=0.1r
b=0.2r
c=0.3r
d=0.4r
e=0.5r
f=0.8r

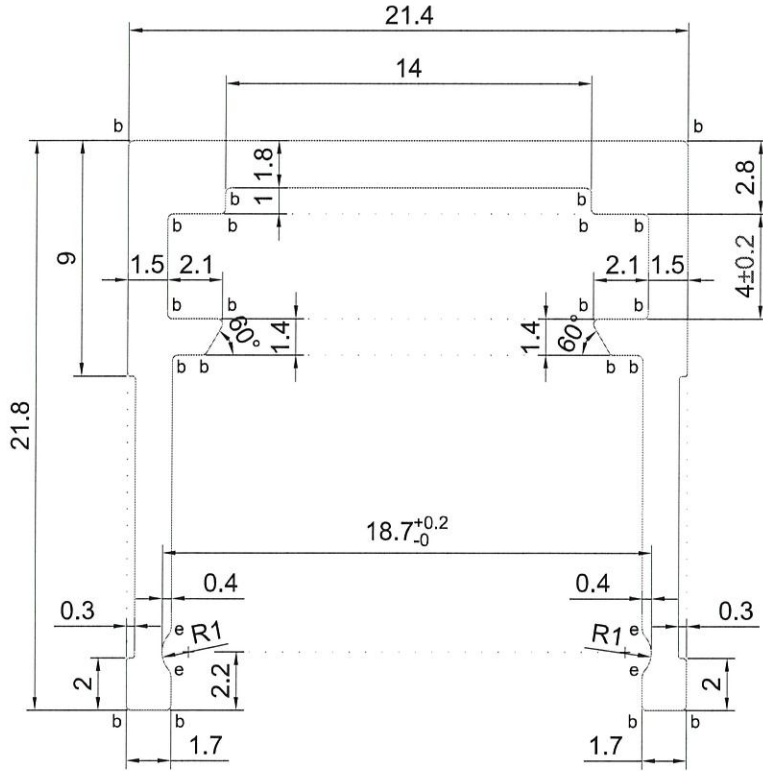

SCALE 4:1

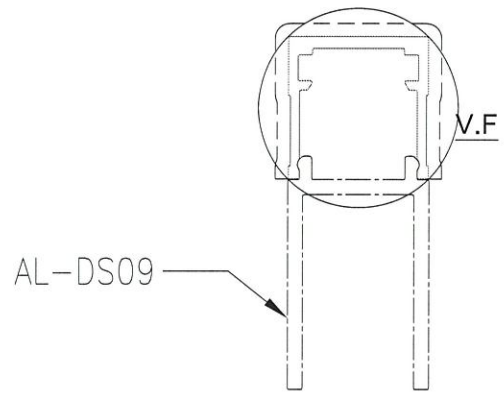
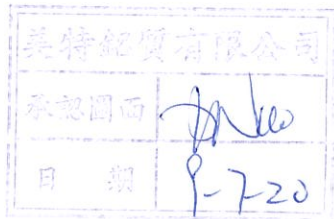

SCALE 1:1

SIGNATURE GRADEING	HIGH SIGNATURE GRADEING	C.C.DIA(MM)	30.55						
AREA (SQ MM)	106.22	UNSPECIFIED THICKNESS	1.4	PERIMETER (MM)	133.42	STANDARD		SCALE	1:1
MASS (KG/M)	0.288	UNSPECIFIED CORNERS	0.1	SURFACE AREA	65.91	ALLOY	6063-T6	VERSION	
COMPANY ISSUE		DRAWA	LHR	DATE	2020-02-29	APELATION		PAGE OF	
		STANDA-		DATE					
		RDIZATION		DATE					
		TO SIGN		DATE					
		AUDITING		DATE					
MARKER	MODIFY	FILE NO	SIGNATURE	DATE	APPROV				

美特鋁質有限公司
MIDI Aluminium Fabricator Ltd.

28

CUSTOMER	CUSTOMER APPROVAL	CUST PART NO.	AL-DS11(0)
		SECTION NO.	185870

a=0.1r
b=0.2r
c=0.3r
d=0.4r
e=0.5r
f=0.8r

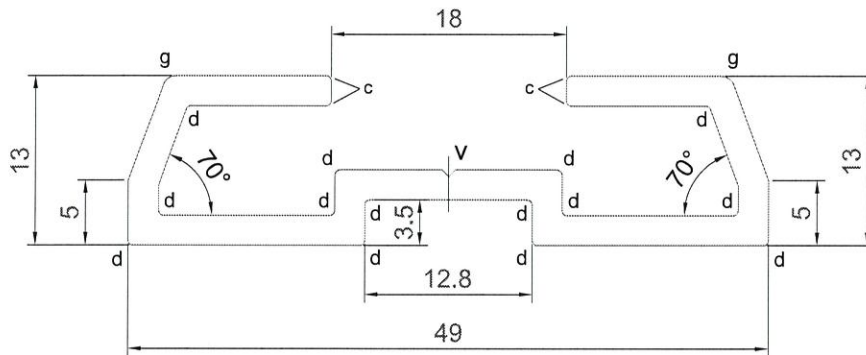

SCALE 2:1

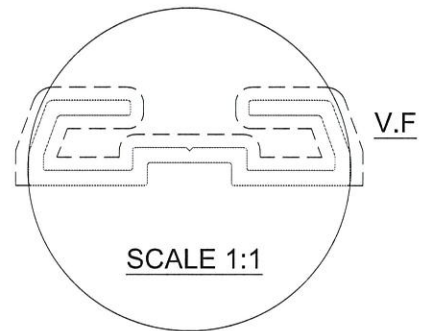
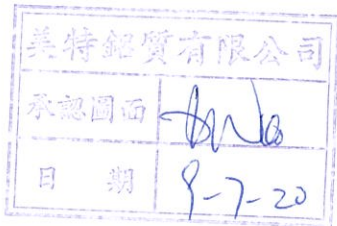

SIGNATURE GRADEING	HIGH SIGNATURE GRADEING	C.C.DIA(MM)	49.26						
AREA (SQ MM)	228.48	UNSPECIFIED THICKNESS	2.3	PERIMETER (MM)	200.91	STANDARD		SCALE	1:1
MASS (KG/M)	0.619	UNSPECIFIED CORNERS	-	SURFACE AREA	146.40	ALLOY	6063-T6	VERSION	
COMPANY ISSUE			DRAWN	LHR	DATE	2020-02-29	APPELLATION	PAGE OF	
			STANDARDIZATION		DATE				
			TO SIGN		DATE				
			AUDITING		DATE				
MARKER	MODIFY	FILE NO	SIGNATURE	DATE	APPROV				

美特鋁質有限公司
MIDI Aluminium Fabricator Ltd.

29

CUSTOMER	CUSTOMER APPROVAL	CUST PART NO.	AL-DS12(0)
		SECTION NO.	28881

$a=0.1r$
 $b=0.2r$
 $c=0.3r$
 $d=0.4r$
 $e=0.5r$
 $f=0.8r$

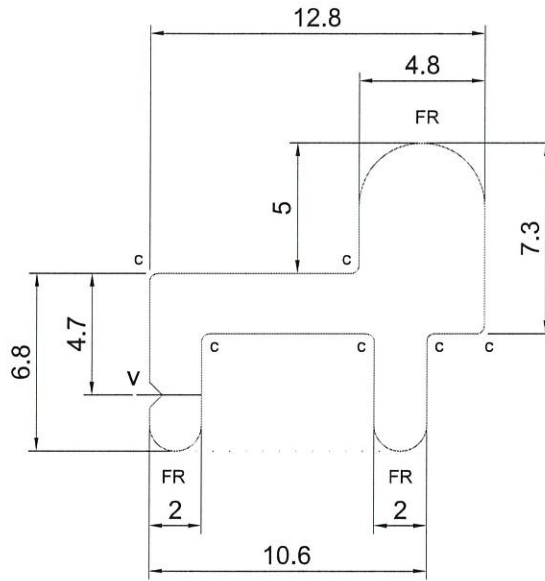

SCALE 4:1

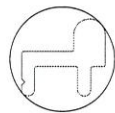
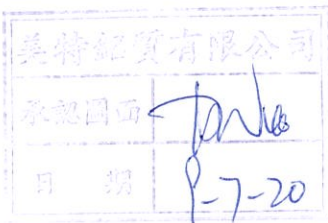

SCALE 1:1

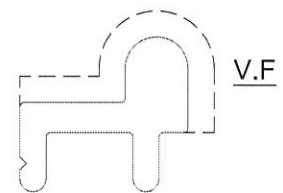

SCALE 2:1

SIGNATURE GRADEING	HIGH SIGNATURE GRADEING	C.C.DIA(MM)	16.01						
AREA (SQ MM)	67.90	UNSPECIFIED THICKNESS	2.3	PERIMETER (MM)	54.06	STANDARD		SCALE	1:1
MASS (KG/M)	0.184	UNSPECIFIED CORNERS	-	SURFACE AREA	23.25	ALLOY	6063-T6	VERSION	
COMPANY ISSUE		DRAWN	LHR	DATE	2020-02-29	APELLATION	PAGE OF		
		STANDARDIZATION		DATE					
		TO SIGN		DATE					
		AUDITING		DATE					
MARKER	MODIFY	FILE NO	SIGNATURE	DATE	APPROV				

CUSTOMER	CUSTOMER APPROVAL	CUST PART NO.	AL-DS13(0)
		SECTION NO.	185872

$a=0.1r$
 $b=0.2r$
 $c=0.3r$
 $d=0.4r$
 $e=0.5r$
 $f=0.8r$

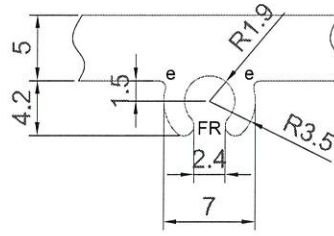

A
2:1

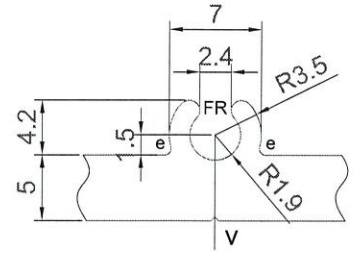

B
2:1

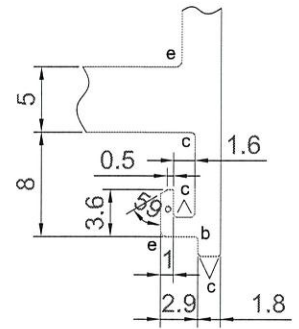

C
2:1

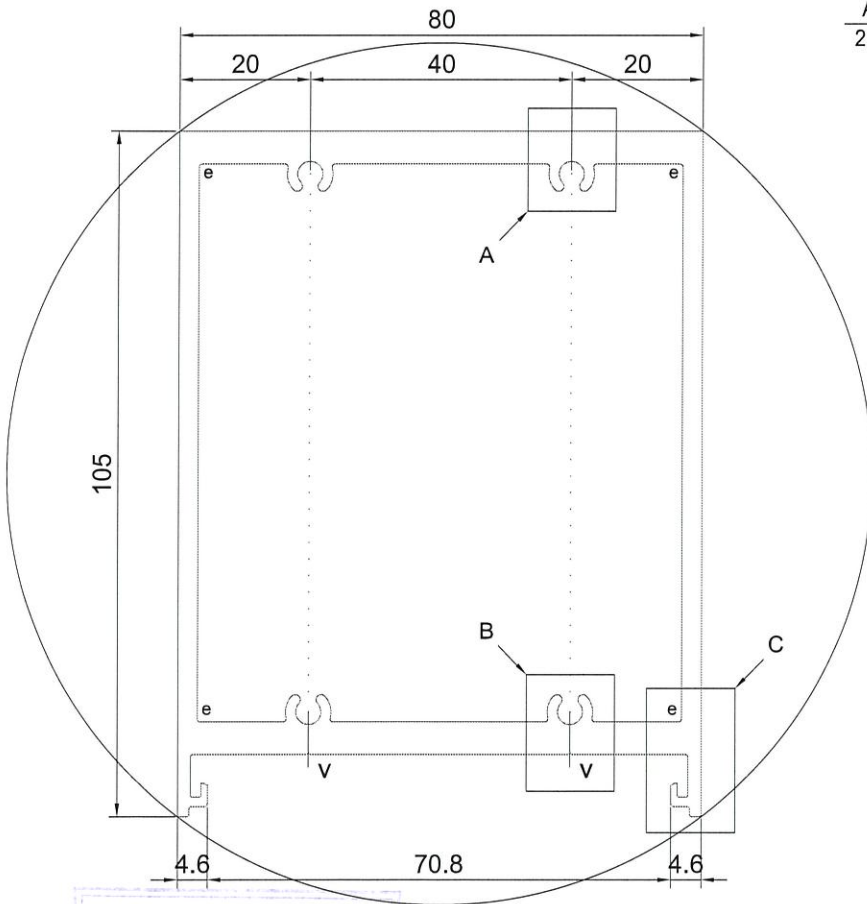

美特鋁質有限公司
 承認圖面
 日期 P-7-20

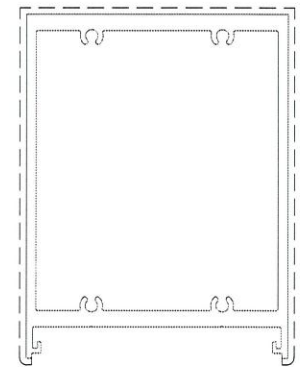

V.F

SCALE 1:2

SIGNATURE GRADEING	HIGH SIGNATURE GRADEING	C.C.DIA(MM)	132.00						
AREA (SQ MM)	1415.03	UNSPECIFIED THICKNESS	3.0	PERIMETER (MM)	405.97	STANDARD		SCALE	1:1
MASS (KG/M)	3.835	UNSPECIFIED CORNERS	-	SURFACE AREA	293.58	ALLOY	6063-T6	VERSION	
COMPANY ISSUE			DRAWN	LHR	DATE	2020-02-29	APELLATION	PAGE OF	
			STANDARDIZATION		DATE				
			TO SIGN		DATE				
			AUDITING		DATE				
MARKER	MODIFY	FILE NO	SIGNATURE	DATE	APPROV	DATE			



 美特鋁質有限公司
 MIDI Aluminium Fabricator Ltd.

CUSTOMER	CUSTOMER APPROVAL	CUST PART NO.	AL-DS14(0)
		SECTION NO.	<i>Handwritten: 2/2/23</i>

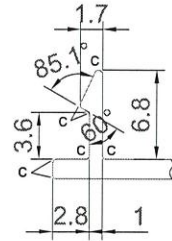
$a=0.1r$
 $b=0.2r$
 $c=0.3r$
 $d=0.4r$
 $e=0.5r$
 $f=0.8r$

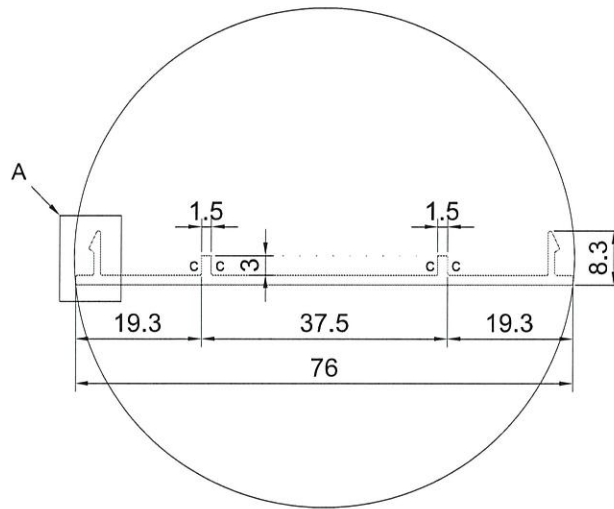

A
2:1



美特鋁質有限公司
 審核圖面 *Handwritten signature*
 日期 P-7-20



V.F

SCALE 1:2

SIGNATURE GRADEING	HIGH SIGNATURE GRADEING	C.C.DIA(MM)	76.45						
AREA (SQ MM)	137.74	UNSPECIFIED THICKNESS	1.5	PERIMETER (MM)	192.51	STANDARD		SCALE	1:1
MASS (KG/M)	0.373	UNSPECIFIED CORNERS	-	SURFACE AREA	76.34	ALLOY	6063-T5	VERSION	
COMPANY ISSUE		DRAWN	LHR	DATE	2020-02-29	APPELLATION		PAGE OF	
		STANDARDIZATION		DATE					
		TO SIGN		DATE					
		AUDITING		DATE					
MARKER	MODIFY	FILE NO	SIGNATURE	DATE	APPROV				

美特鋁質有限公司
 MIDI Aluminium Fabricator Ltd.

Handwritten: 32

CUSTOMER	CUSTOMER APPROVAL	CUST PART NO.	AL-DS15(0)
		SECTION NO.	25894

a=0.1r
b=0.2r
c=0.3r
d=0.4r
e=0.5r
f=0.8r

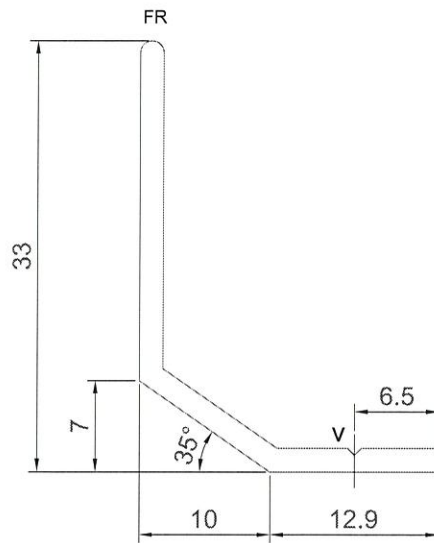

SCALE 2:1

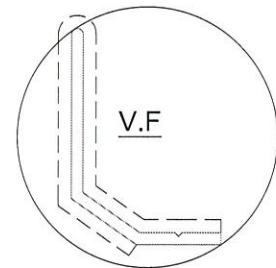
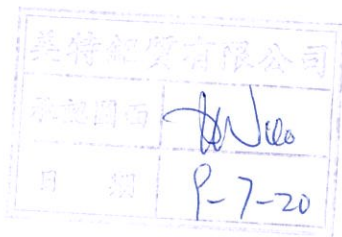

SCALE 1:1

SIGNATURE GRADEING	HIGH SIGNATURE GRADEING	C.C.DIA(MM)	39.82						
AREA (SQ MM)	88.71	UNSPECIFIED THICKNESS	1.8	PERIMETER (MM)	102.47	STANDARD		SCALE	1:1
MASS (KG/M)	0.240	UNSPECIFIED CORNERS	-	SURFACE AREA	87.76	ALLOY	6063-T5	VERSION	
COMPANY ISSUE		DRAWN	LHR	DATE	2020-02-29	APELLATION	PAGE OF		
		STANDARDIZATION		DATE		 美特鋁質有限公司 MIDI Aluminium Fabricator Ltd.			
		TO SIGN		DATE					
		AUDITING		DATE					
MARKER	MODIFY	FILE NO	SIGNATURE	DATE	APPROV				

CUSTOMER	CUSTOMER APPROVAL	CUST PART NO.	AL-DS16(0)
		SECTION NO.	25875

$a=0.1r$
 $b=0.2r$
 $c=0.3r$
 $d=0.4r$
 $e=0.5r$
 $f=0.8r$

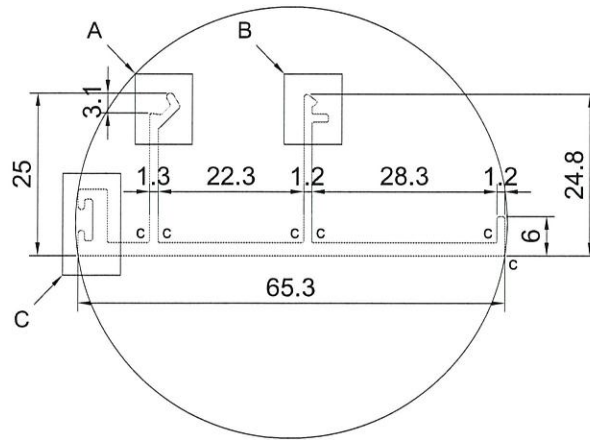
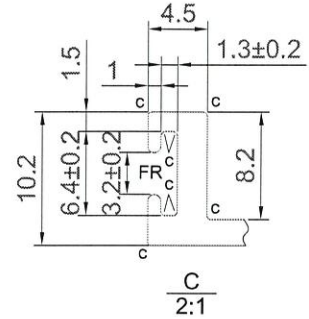
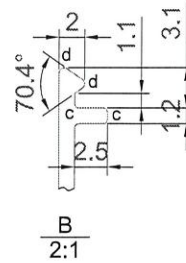
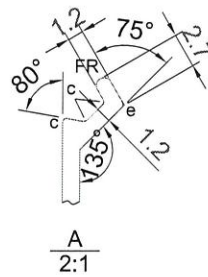

美特鋁質有限公司	
承認圖面	<i>[Signature]</i>
日期	9-7-20

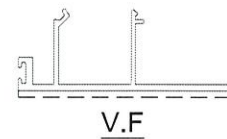

SCALE 1:2

SIGNATURE GRADEING	HIGH SIGNATURE GRADEING	C.C.DIA(MM)	66.09						
AREA (SQ MM)	224.59	UNSPECIFIED THICKNESS	2.0	PERIMETER (MM)	266.67	STANDARD		SCALE	1:1
MASS (KG/M)	0.609	UNSPECIFIED CORNERS	-	SURFACE AREA	65.64	ALLOY	6063-T6	VERSION	
COMPANY ISSUE			DRAWN	LHR	DATE	2020-02-29	APELLATION	PAGE OF	
			STANDARDIZATION		DATE				
			TO SIGN		DATE				
			AUDITING		DATE				
MARKER	MODIFY	FILE NO	SIGNATURE	DATE	APPROV		DATE		

美特鋁質有限公司
 MIDI Aluminium Fabricator Ltd.

34

CUSTOMER	CUSTOMER APPROVAL	CUST PART NO.	AL-DS17(0)
		SECTION NO.	2-15 876

a=0.1r
b=0.2r
c=0.3r
d=0.4r
e=0.5r
f=0.8r

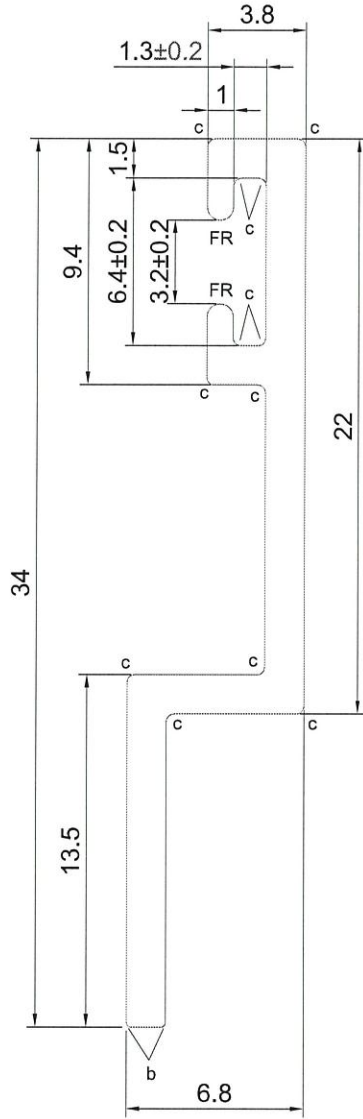

SCALE 4:1

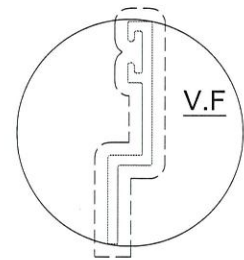

SCALE 1:1

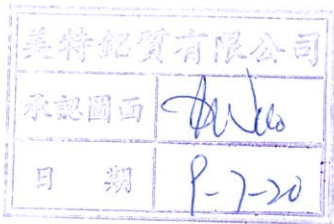

SIGNATURE GRADEING	HIGH SIGNATURE GRADEING	C.C.DIA(MM)	34.66						
AREA (SQ MM)	68.65	UNSPECIFIED THICKNESS	1.5	PERIMETER (MM)	94.50	STANDARD		SCALE	1:1
MASS (KG/M)	0.186	UNSPECIFIED CORNERS	-	SURFACE AREA	94.50	ALLOY	6063-T6	VERSION	
COMPANY ISSUE			DRAWN	LHR	DATE	2020-02-29	APELLATION	PAGE OF	
			STANDARDIZATION		DATE		 美特鋁質有限公司 MIDI Aluminium Fabricator Ltd.		
			TO SIGN		DATE				
			AUDITING		DATE				
MARKER	MODIFY	FILE NO	SIGNATURE	DATE	APPROV	DATE			

35

CUSTOMER	CUSTOMER APPROVAL	CUST PART NO.	AL-DS18(0)
		SECTION NO.	185877

$a=0.1r$
 $b=0.2r$
 $c=0.3r$
 $d=0.4r$
 $e=0.5r$
 $f=0.8r$
 $g=1.0r$
 $h=2.0r$

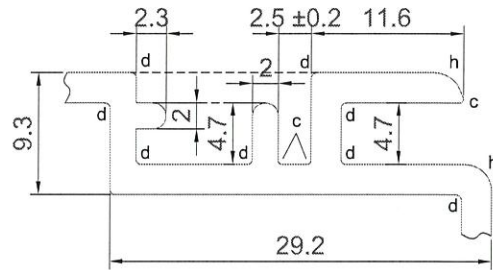

A
2:1

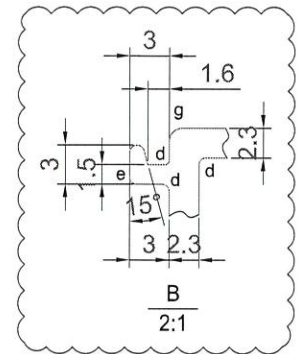
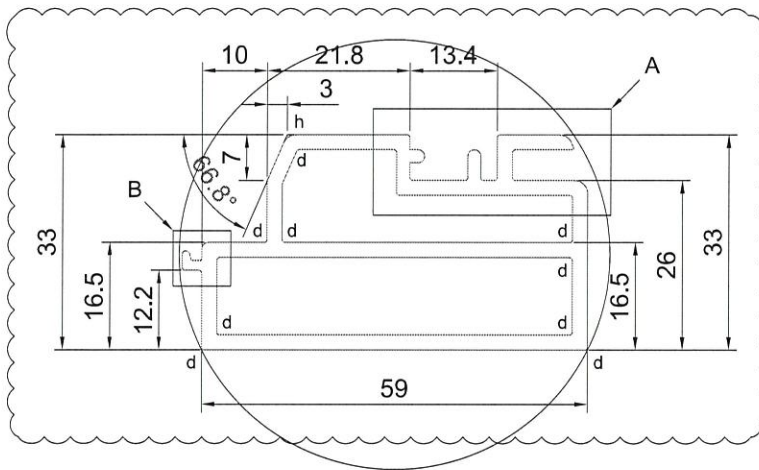

B
2:1

美特鋁質有限公司
 承認圖面
 日期 P-7-20

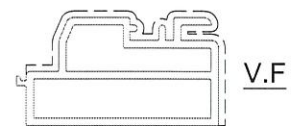
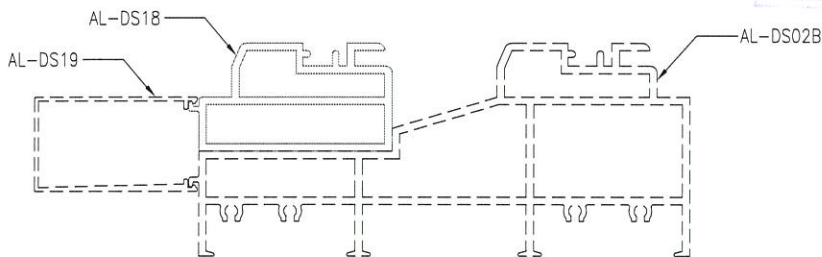

SCALE 1:2

SIGNATURE GRADEING	HIGH SIGNATURE GRADEING	C.C.DIA(MM)	65.86						
AREA (SQ MM)	552.01	UNSPECIFIED THICKNESS	2.3	PERIMETER (MM)	229.67	STANDARD		SCALE	1:1
MASS (KG/M)	1.496	UNSPECIFIED CORNERS	-	SURFACE AREA	148.02	ALLOY	6063-T6	VERSION	A
COMPANY ISSUE		DRAWN	LHR	DATE	2020-02-29	APELLATION	PAGE OF		
		STANDARDIZATION		DATE		美特鋁質有限公司 MIDI Aluminium Fabricator Ltd.			
		TO SIGN		DATE					
		AUDITING		DATE					
MARKER	MODIFY	FILE NO	SIGNATURE	DATE	APPROV	DATE			

36

CUSTOMER	CUSTOMER APPROVAL	CUST PART NO.	AL-DS19(0)
		SECTION NO.	<i>xjs878</i>

$a=0.1r$
 $b=0.2r$
 $c=0.3r$
 $d=0.4r$
 $e=0.5r$
 $f=0.8r$
 $g=1.0r$
 $h=2.0r$

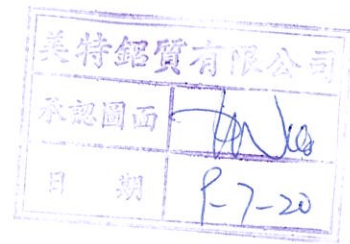
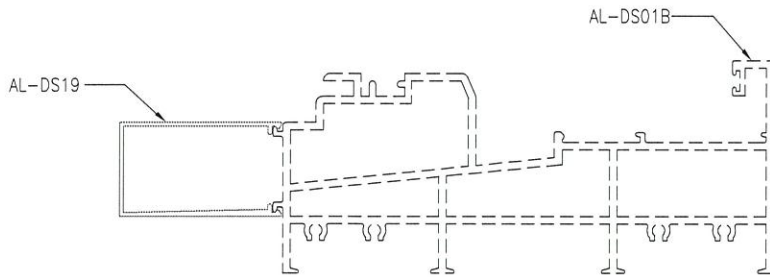
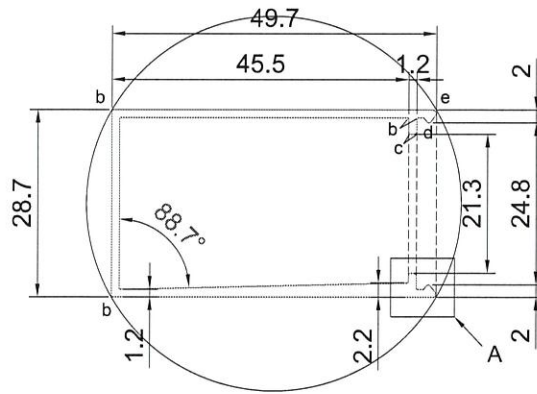
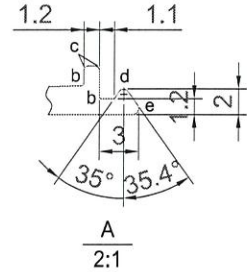

SCALE 1:2

SIGNATURE GRADEING	HIGH SIGNATURE GRADEING	C.C.DIA(MM)	57.40						
AREA (SQ MM)	179.97	UNSPECIFIED THICKNESS	1.2	PERIMETER (MM)	262.23	STANDARD		SCALE	1:1
MASS (KG/M)	0.488	UNSPECIFIED CORNERS	-	SURFACE AREA	129.12	ALLOY	6063-T6	VERSION	
COMPANY ISSUE		DRAWN	LHR	DATE	2020-06-17	APPELLATION		PAGE OF	
		STANDARDIZATION		DATE					
		TO SIGN		DATE					
		AUDITING		DATE					
MARKER	MODIFY	FILE NO	SIGNATURE	DATE	APPROV				

美特鋁質有限公司
 MIDI Aluminium Fabricator Ltd.

37

CUSTOMER	CUSTOMER APPROVAL	CUST PART NO.	AL-TS01(0)
		SECTION NO.	X-85879

$a=0.1r$
 $b=0.2r$
 $c=0.3r$
 $d=0.4r$
 $e=0.5r$
 $f=0.8r$
 $g=1.0r$
 $j=1.5r$
 $h=2.0r$

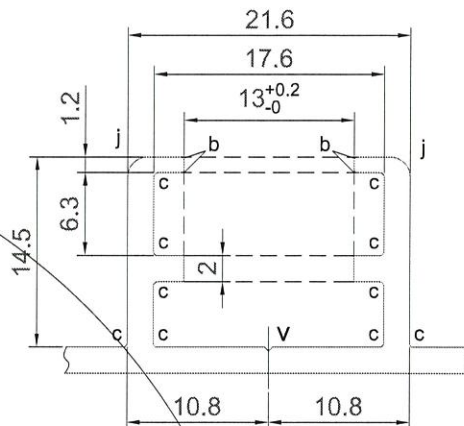
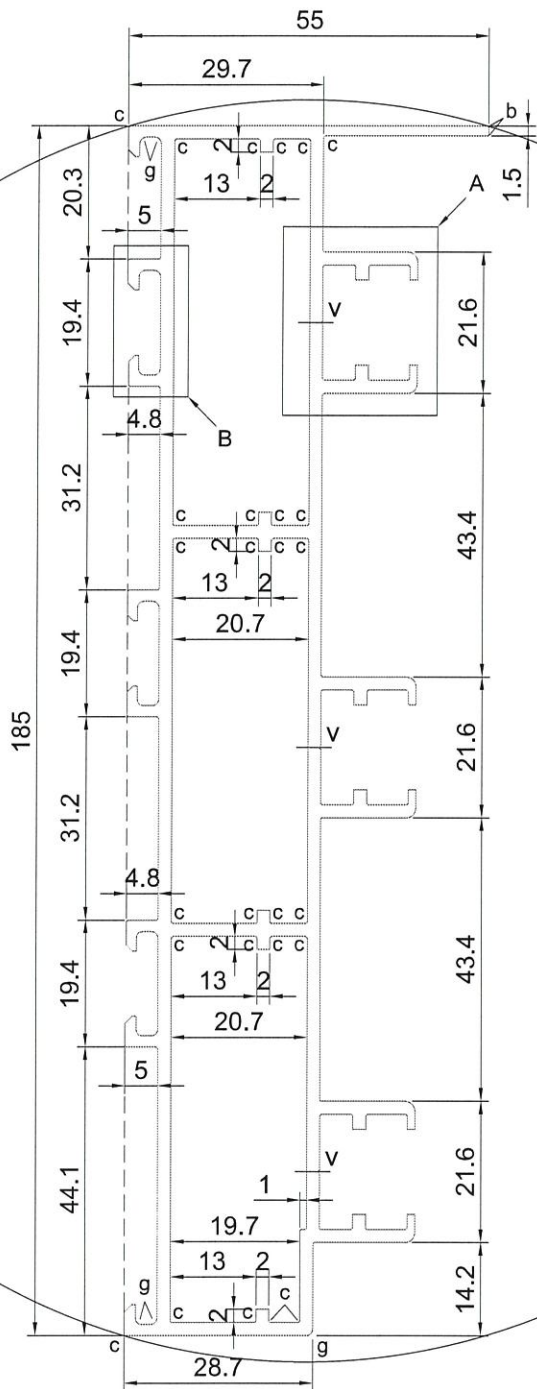

A
2:1

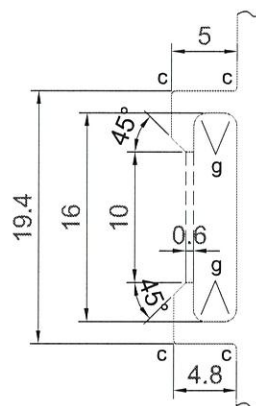

B
2:1

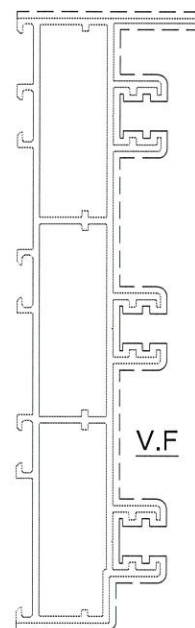

SCALE 1:2

美特鋁質有限公司
 承認圖面
 日期 P-7-20

SIGNATURE GRADEING	HIGH SIGNATURE GRADEING	C.C.DIA(MM)	193.00							
AREA (SQ MM)	1287.77	UNSPECIFIED THICKNESS	2.0	PERIMETER (MM)	804.53	STANDARD		SCALE	1:1	
MASS (KG/M)	3.490	UNSPECIFIED CORNERS	-	SURFACE AREA	516.83	ALLOY	6063-T6	VERSION		
COMPANY ISSUE			DRAWN	LHR	DATE	2020-02-29	APPELLATION	PAGE OF		
			STANDARDIZATION		DATE					
			TO SIGN		DATE					
			AUDITING		DATE					
MARKER	MODIFY	FILE NO	SIGNATURE	DATE	APPROV	DATE				

 美特鋁質有限公司
 MIDI Aluminium Fabricator Ltd.

38

CUSTOMER	CUSTOMER APPROVAL	CUST PART NO.	AL-TS02(0)
		SECTION NO.	2-8588

$a=0.1r$
 $b=0.2r$
 $c=0.3r$
 $d=0.4r$
 $e=0.5r$
 $f=0.8r$
 $g=1.0r$
 $j=1.5r$
 $h=2.0r$

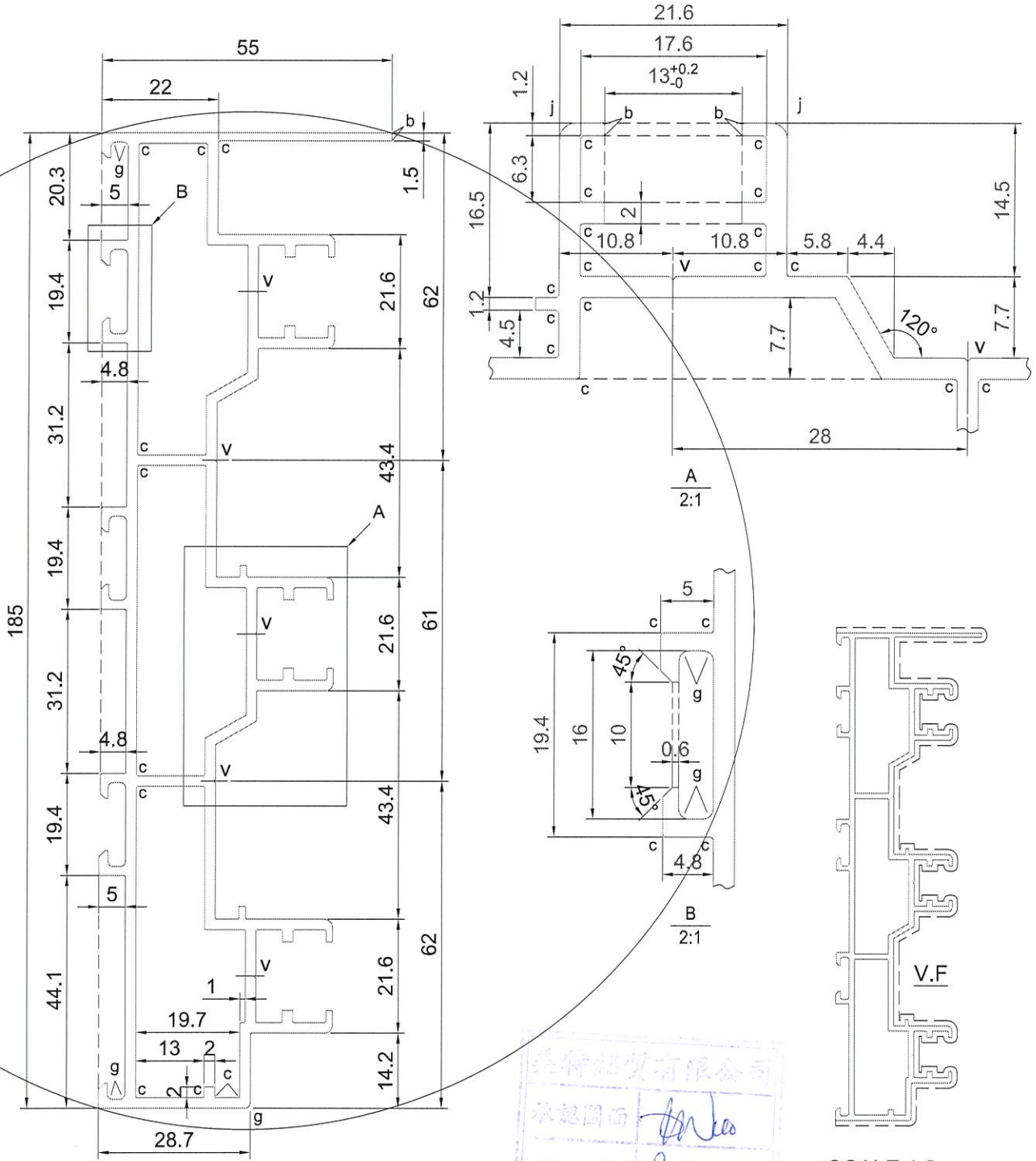

美特鋁質有限公司
 承認圖面
 日期 P-7-20

SCALE 1:2

SIGNATURE GRADE/ING	HIGH SIGNATURE GRADE/ING	C.C.DIA(MM)	193.00							
AREA (SQ MM)	1302.22	UNSPECIFIED THICKNESS	2.0	PERIMETER (MM)	852.38	STANDARD			SCALE	1:1
MASS (KG/M)	3.529	UNSPECIFIED CORNERS	-	SURFACE AREA	564.67	ALLOY	6063-T6	VERSION		
COMPANY ISSUE			DRAWN	LHR	DATE	2020-02-29	APELLATION	PAGE OF		
			STANDARDIZATION		DATE					
			TO SIGN		DATE					
			AUDITING		DATE					
MARKER	MODIFY	FILE NO	SIGNATURE	DATE	APPROV	DATE				

美特鋁質有限公司
 MIDI Aluminium Fabricator Ltd.

39

CUSTOMER	CUSTOMER APPROVAL	CUST PART NO.	AL-TS02B(0)
		SECTION NO.	X85881

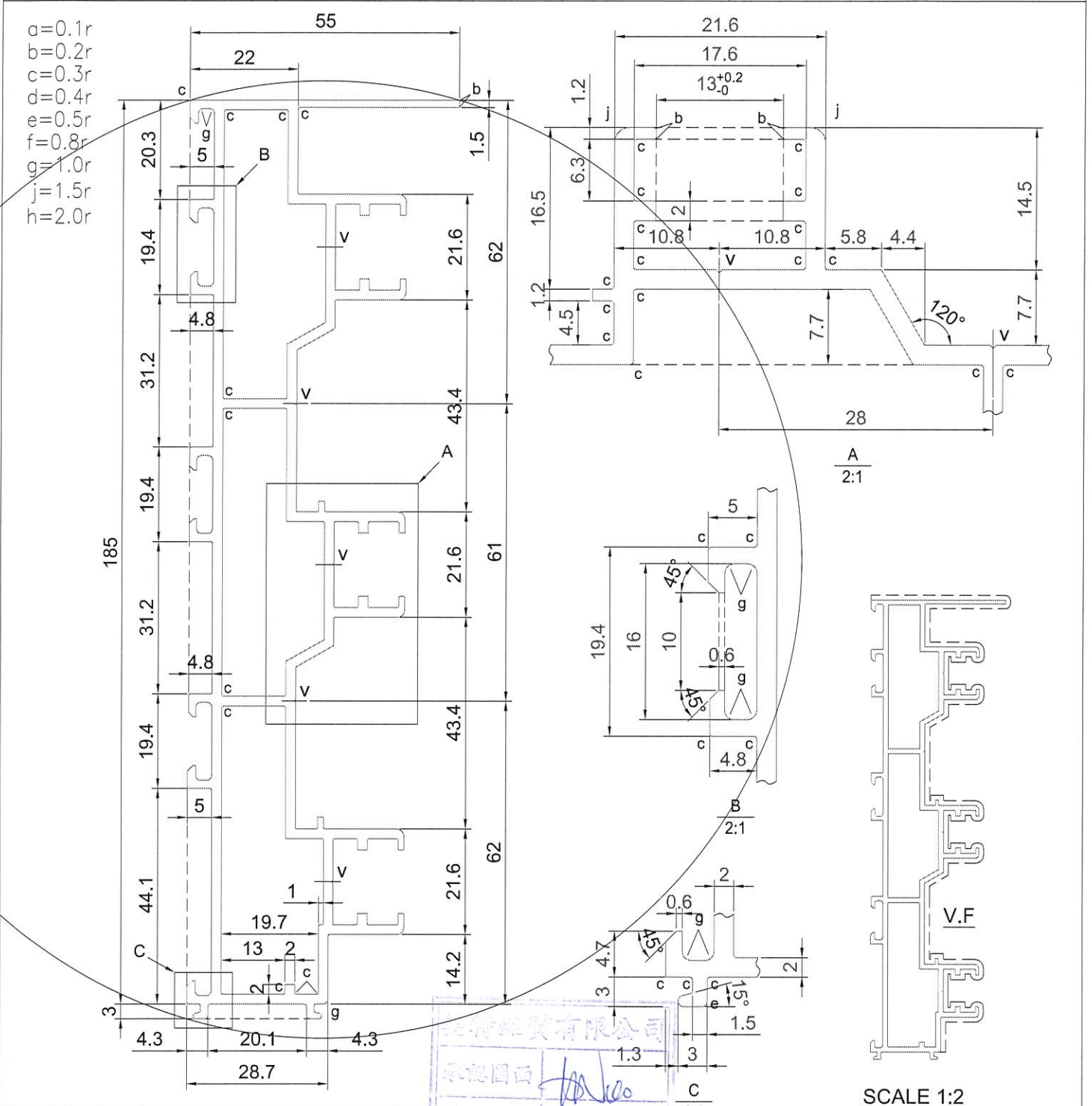

SIGNATURE GRADEING	HIGH SIGNATURE GRADEING	C.C.DIA(MM)	195.88	美特鋁質有限公司 承認圖章 8-7-20					
AREA (SQ MM)	1314.65	UNSPECIFIED THICKNESS	2.0	PERIMETER (MM)	867.82	STANDARD		SCALE	1:1
MASS (KG/M)	3.563	UNSPECIFIED CORNERS	-	SURFACE AREA	536.80	ALLOY	6063-T6	VERSION	
COMPANY ISSUE		DRAWN	LHR	DATE	2020-06-17	APELLATION	PAGE OF		
		STANDARDIZATION		DATE		 美特鋁質有限公司 MIDI Aluminium Fabricator Ltd.			
		TO SIGN		DATE					
		AUDITING		DATE					
MARKER	MODIFY	FILE NO	SIGNATURE	DATE	APPROV	DATE			

CUSTOMER	CUSTOMER APPROVAL	CUST PART NO.	AL-TS03(0)
		SECTION NO.	<i>Handwritten signature</i>

$a=0.1r$
 $b=0.2r$
 $c=0.3r$
 $d=0.4r$
 $e=0.5r$
 $f=0.8r$
 $g=1.0r$
 $h=2.0r$

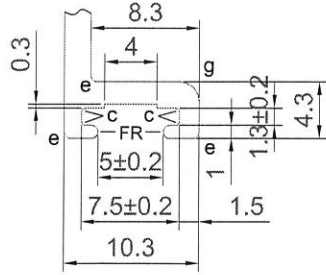

A
2:1

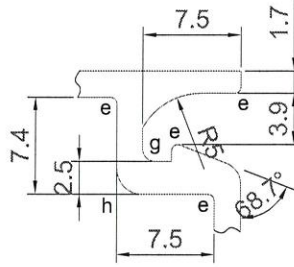

B
2:1

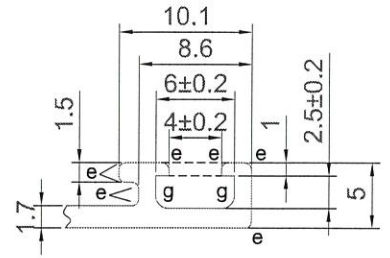

C
2:1

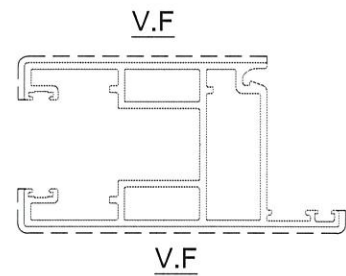
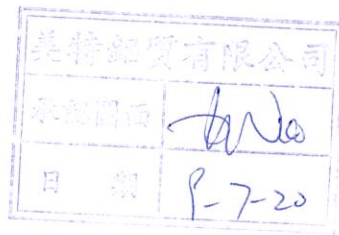
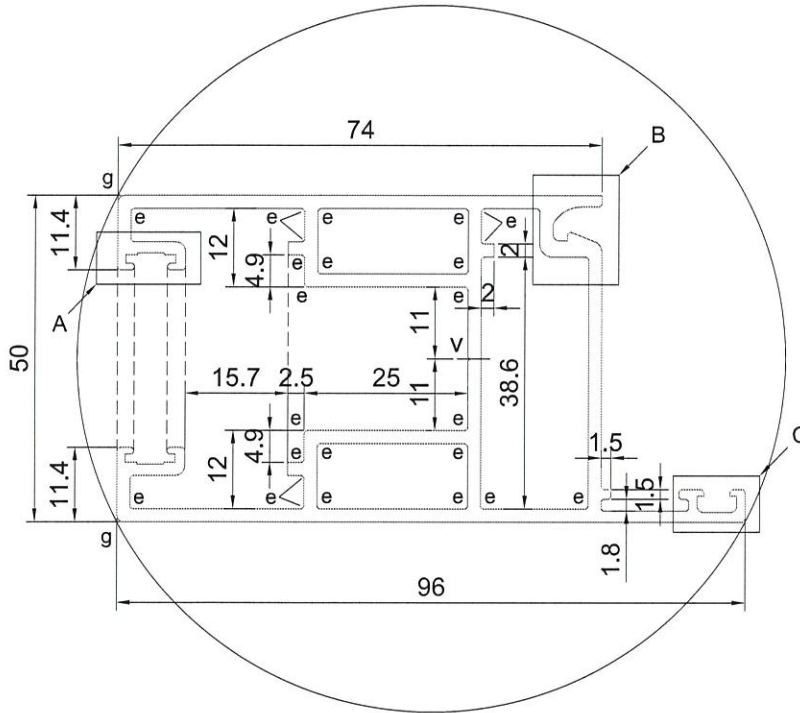

SCALE 1:2

SIGNATURE GRADEING	HIGH SIGNATURE GRADEING	C.C.DIA(MM)	108.24						
AREA (SQ MM)	783.24	UNSPECIFIED THICKNESS	2.0	PERIMETER (MM)	525.99	STANDARD		SCALE	1:1
MASS (KG/M)	2.122	UNSPECIFIED CORNERS	-	SURFACE AREA	197.59	ALLOY	6063-T6	VERSION	
COMPANY ISSUE			DRAWN	LHR	DATE	2020-02-29	APELLATION	PAGE OF	
			STANDARDIZATION		DATE				
			TO SIGN		DATE				
			AUDITING		DATE				
MARKER	MODIFY	FILE NO	SIGNATURE	DATE	APPROV	DATE			

美特鋁質有限公司
 MIDI Aluminium Fabricator Ltd.

Handwritten mark

CUSTOMER	CUSTOMER APPROVAL	CUST PART NO.	AL-TS04(0)
		SECTION NO.	285883

$a=0.1r$
 $b=0.2r$
 $c=0.3r$
 $d=0.4r$
 $e=0.5r$
 $f=0.8r$
 $g=1.0r$
 $h=2.0r$

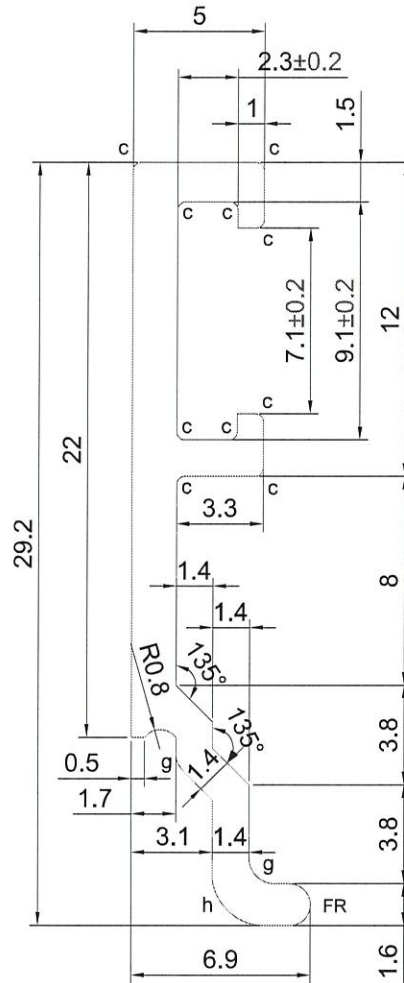

SCALE 4:1

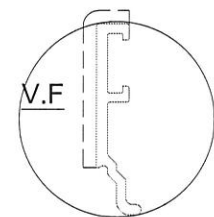
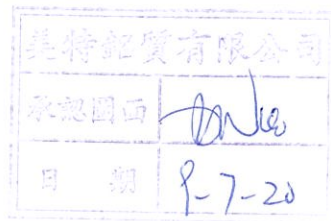

SCALE 1:1

SIGNATURE GRADEING	HIGH SIGNATURE GRADEING	C.C.DIA(MM)	29.84						
AREA (SQ MM)	64.25	UNSPECIFIED THICKNESS	1.7	PERIMETER (MM)	83.73	STANDARD		SCALE	1:1
MASS (KG/M)	0.174	UNSPECIFIED CORNERS	-	SURFACE AREA	27.04	ALLOY	6063-T6	VERSION	
COMPANY ISSUE		DRAWN	LHR	DATE	2020-02-29	APELLATION	PAGE OF		
		STANDARDIZATION		DATE					
		TO SIGN		DATE					
		AUDITING		DATE					
MARKER	MODIFY	FILE NO	SIGNATURE	DATE	APPROV	DATE			

CUSTOMER	CUSTOMER APPROVAL	CUST PART NO.	AL-TS05(0)
		SECTION NO.	XJ5884

a=0.1r
b=0.2r
c=0.3r
d=0.4r
e=0.5r
f=0.8r

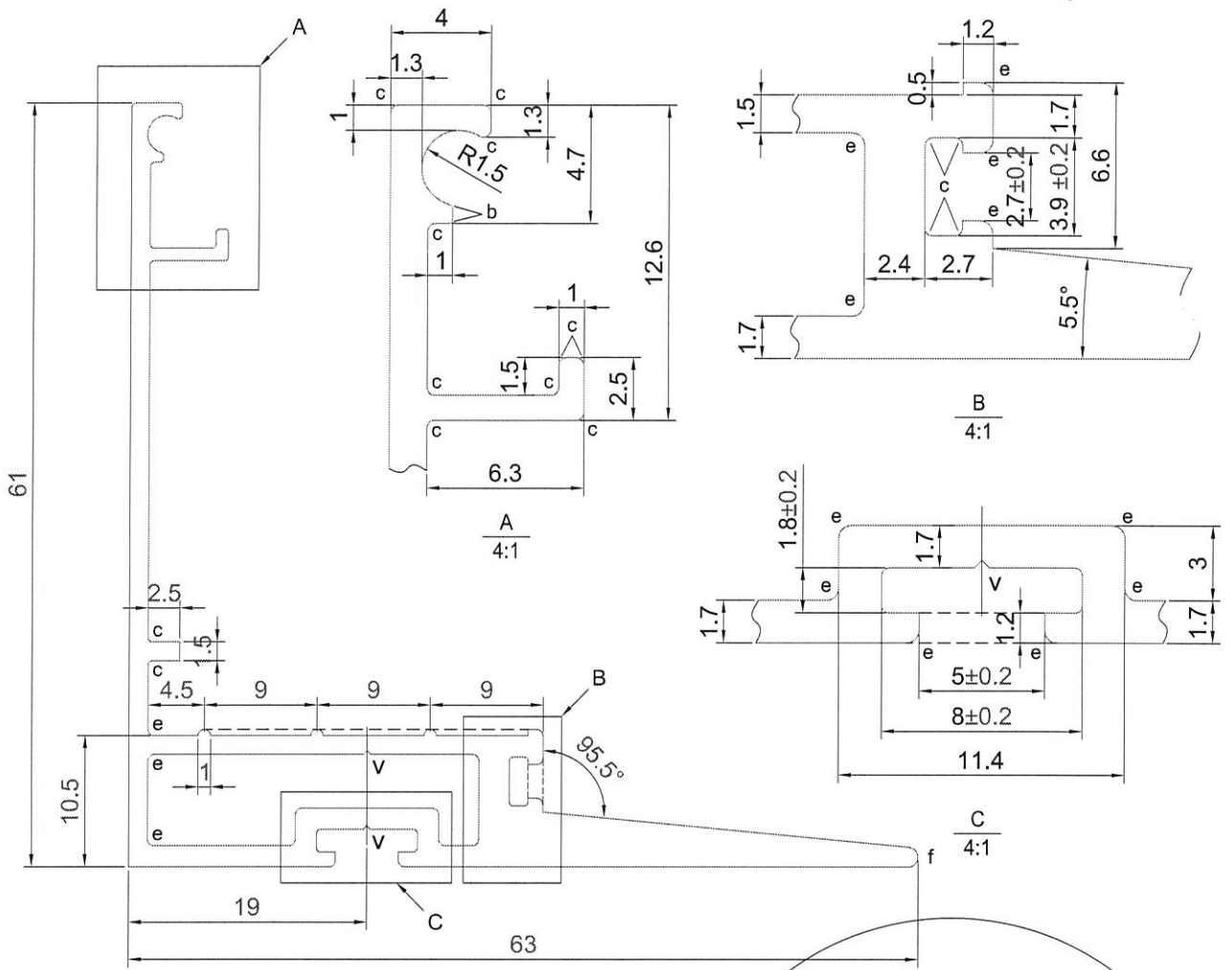

美特鋁質有限公司
承認圖面
日期 9-7-20

SIGNATURE GRADEING	HIGH SIGNATURE GRADEING	C.C.DIA(MM)	87.66						
AREA (SQ MM)	339.60	UNSPECIFIED THICKNESS	1.5	PERIMETER (MM)	299.37	STANDARD		SCALE	1:1
MASS (KG/M)	0.920	UNSPECIFIED CORNERS	-	SURFACE AREA	140.94	ALLOY	6063-T6	VERSION	
COMPANY ISSUE			DRAWN	LHR	DATE	2020-02-29	APPELLATION	PAGE OF	
			STANDARDIZATION		DATE				
			TO SIGN		DATE				
			AUDITING		DATE				
MARKER	MODIFY	FILE NO	SIGNATURE	DATE	APPROV				

美特鋁質有限公司
MIDI Aluminium Fabricator Ltd.

CUSTOMER	CUSTOMER APPROVAL	CUST PART NO.	AL-TS06(0)
		SECTION NO.	25885

$a=0.1r$
 $b=0.2r$
 $c=0.3r$
 $d=0.4r$
 $e=0.5r$
 $f=0.8r$

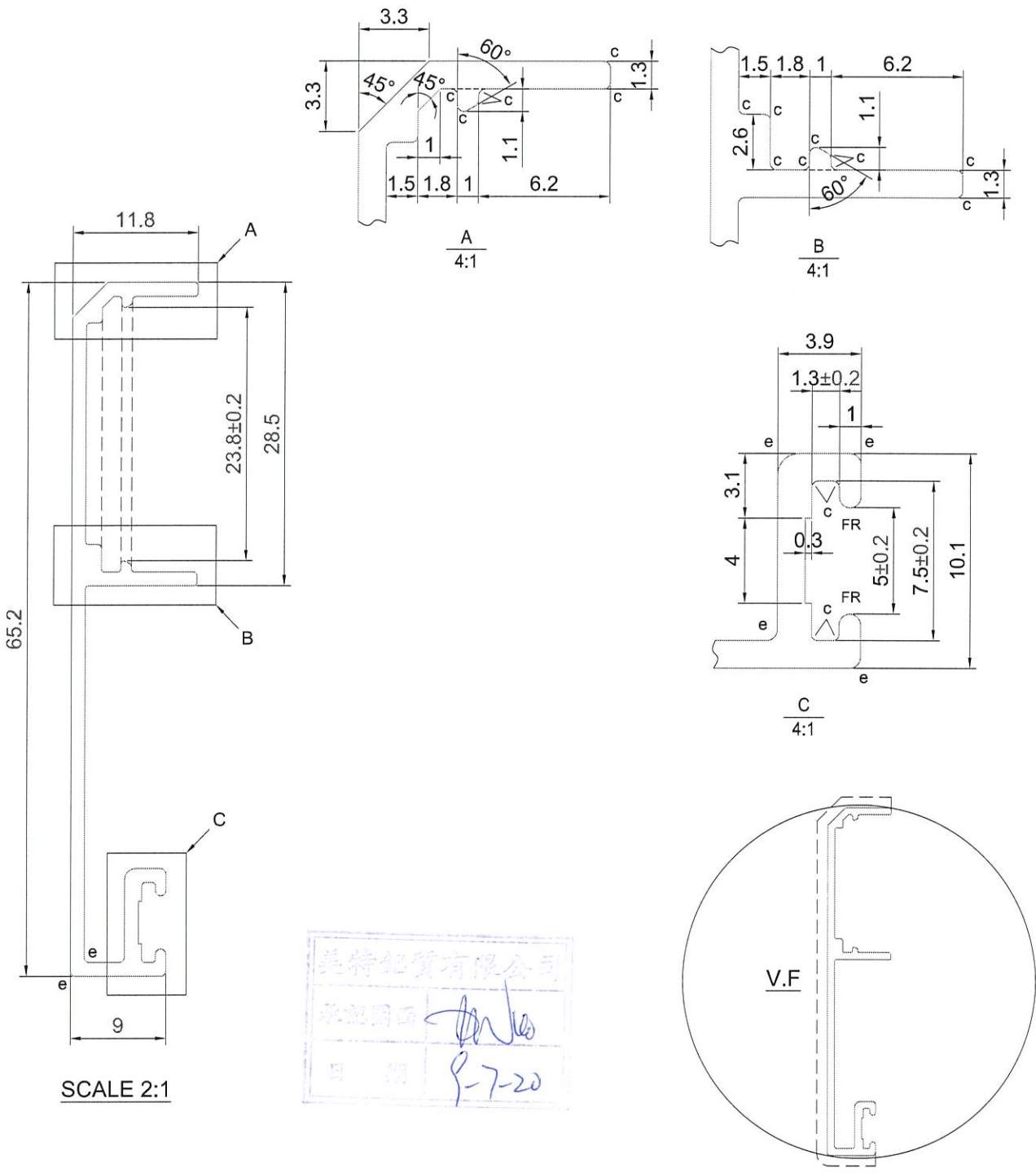

SCALE 2:1

SCALE 1:1

SIGNATURE GRADEING	HIGH SIGNATURE GRADEING	C.C.DIA(MM)	66.26						
AREA (SQ MM)	144.65	UNSPECIFIED THICKNESS	1.3	PERIMETER (MM)	214.33	STANDARD		SCALE	1:1
MASS (KG/M)	0.392	UNSPECIFIED CORNERS	-	SURFACE AREA	84.31	ALLOY	6063-T6	VERSION	
COMPANY ISSUE			DRAWN	LHR	DATE	2020-02-29	APELLATION	PAGE OF	
			STANDARDIZATION		DATE				
			TO SIGN		DATE				
			AUDITING		DATE				
MARKER	MODIFY	FILE NO	SIGNATURE	DATE	APPROV				

美特鋁質有限公司
 MIDI Aluminium Fabricator Ltd.

46

CUSTOMER	CUSTOMER APPROVAL	CUST PART NO.	AL-TS07(0)
		SECTION NO.	x 2886

$a=0.1r$
 $b=0.2r$
 $c=0.3r$
 $d=0.4r$
 $e=0.5r$
 $f=0.8r$

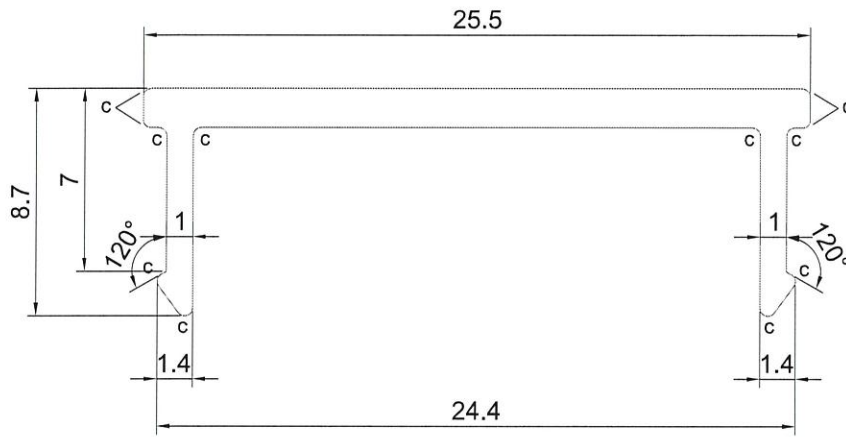

SCALE 4:1

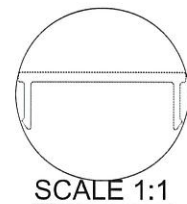
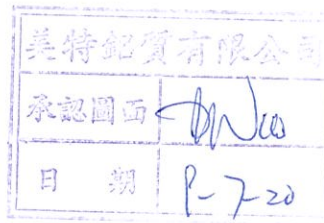

SIGNATURE GRADEING	HIGH SIGNATURE GRADEING	C.C.DIA(MM)	26.37						
AREA (SQ MM)	52.61	UNSPECIFIED THICKNESS	1.5	PERIMETER (MM)	81.28	STANDARD		SCALE	1:1
MASS (KG/M)	0.143	UNSPECIFIED CORNERS	-	SURFACE AREA	-	ALLOY	6063-T5	VERSION	
COMPANY ISSUE		DRAWN	LHR	DATE	2020-02-29	APELLATION	PAGE OF		
		STANDARDIZATION		DATE					
		TO SIGN		DATE					
		AUDITING		DATE					
MARKER	MODIFY	FILE NO	SIGNATURE	DATE	APPROV				

45

CUSTOMER	CUSTOMER APPROVAL	CUST PART NO.	AL-TS08(0)
		SECTION NO.	2-85887

$a=0.1r$
 $b=0.2r$
 $c=0.3r$
 $d=0.4r$
 $e=0.5r$
 $f=0.8r$

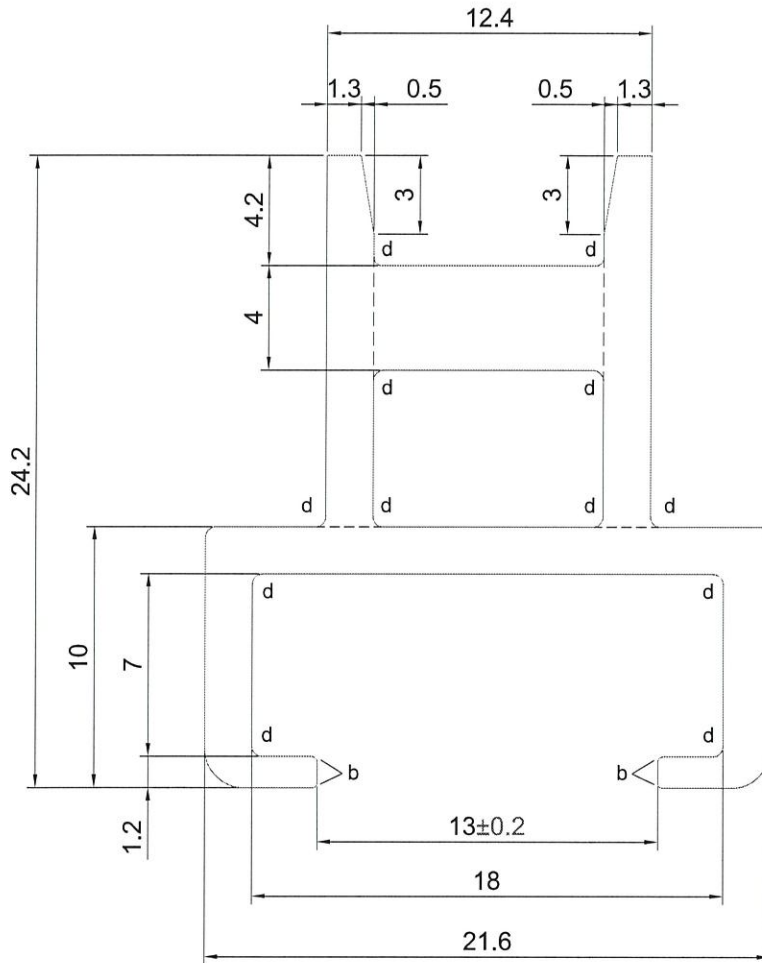

SCALE 4:1

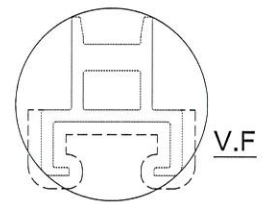
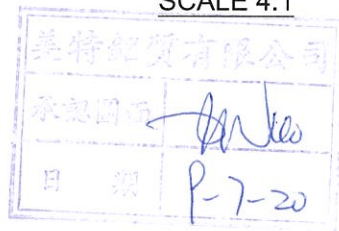

SCALE 1:1

SIGNATURE GRADEING	HIGH SIGNATURE GRADEING	C.C.DIA(MM)	29.40						
AREA (SQ MM)	158.53	UNSPECIFIED THICKNESS	1.5	PERIMETER (MM)	122.22	STANDARD		SCALE	1:1
MASS (KG/M)	0.430	UNSPECIFIED CORNERS	-	SURFACE AREA	66.14	ALLOY	6063-T6	VERSION	
COMPANY ISSUE			DRAWN	LHR	DATE	2020-02-29	APELLATION	PAGE OF	
			STANDARDIZATION		DATE				
			TO SIGN		DATE				
			AUDITING		DATE				
MARKER	MODIFY	FILE NO	SIGNATURE	DATE	APPROV	DATE			

美特鋁質有限公司
 MIDI Aluminium Fabricator Ltd.

46

CUSTOMER	CUSTOMER APPROVAL	CUST PART NO.	AL-TS09(0)
		SECTION NO.	<i>Handwritten signature</i>

$a=0.1r$
 $b=0.2r$
 $c=0.3r$
 $d=0.4r$
 $e=0.5r$
 $f=0.8r$

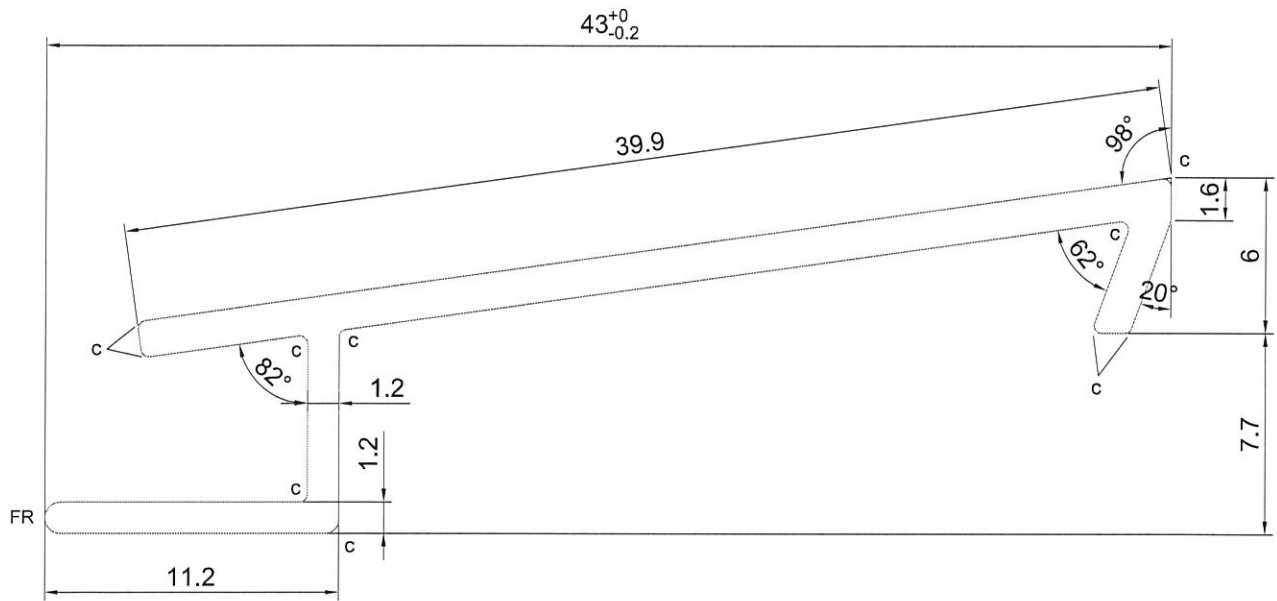

SCALE 4:1

美特鋁質有限公司
 承認圖面 *ten Jiao*
 日期 P-7-20

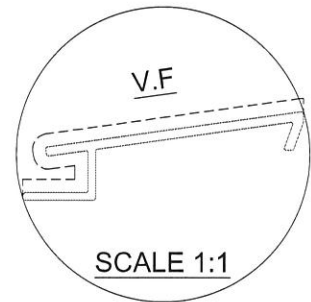

SIGNATURE GRADEING	HIGH SIGNATURE GRADEING	C.C.DIA(MM)	44.97						
AREA (SQ MM)	83.36	UNSPECIFIED THICKNESS	1.4	PERIMETER (MM)	124.94	STANDARD		SCALE	1:1
MASS (KG/M)	0.226	UNSPECIFIED CORNERS	-	SURFACE AREA	64.96	ALLOY	6063-T5	VERSION	
COMPANY ISSUE			DRAWN	LHR	DATE	2020-02-29	APELLATION	PAGE OF	
			STANDARDIZATION		DATE				
			TO SIGN		DATE				
			AUDITING		DATE				
MARKER	MODIFY	FILE NO	SIGNATURE	DATE	APPROV	DATE			

美特鋁質有限公司
 MIDI Aluminium Fabricator Ltd.

Handwritten initials

CUSTOMER	CUSTOMER APPROVAL	CUST PART NO.	AL-TS11(0)
		SECTION NO.	X85890

a=0.1r
b=0.2r
c=0.3r
d=0.4r
e=0.5r
f=0.8r

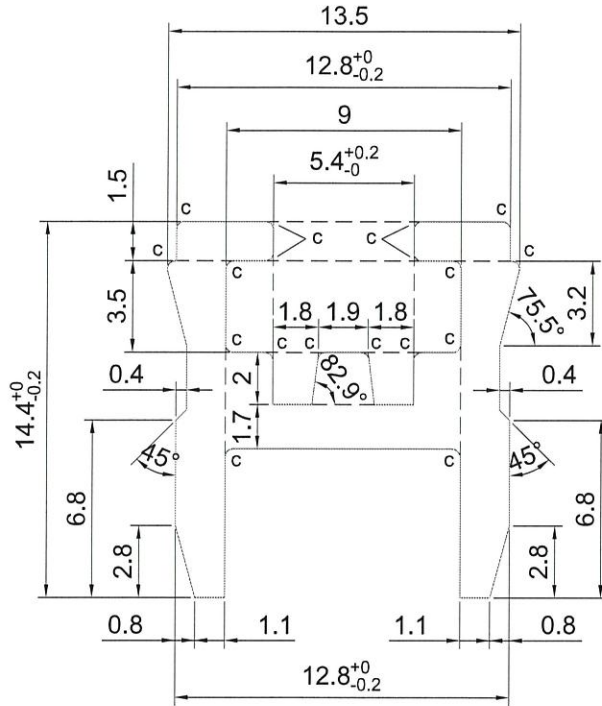

SCALE 4:1

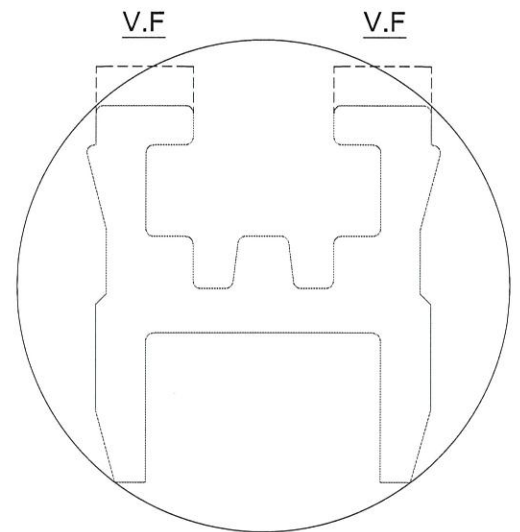

SCALE 1:1

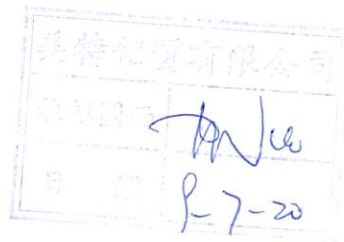

SIGNATURE GRADEING	HIGH SIGNATURE GRADEING	C.C.DIA(MM)	75.20						
AREA (SQ MM)	82.77	UNSPECIFIED THICKNESS	-	PERIMETER (MM)	87.75	STANDARD		SCALE	1:1
MASS (KG/M)	0.224	UNSPECIFIED CORNERS	-	SURFACE AREA	8.08	ALLOY	6063-T6	VERSION	
COMPANY ISSUE		DRAWN	LHR	DATE	2020-02-29	APELLATION	PAGE OF		
		STANDARDIZATION		DATE		 美特鋁質有限公司 MIDI Aluminium Fabricator Ltd.			
		TO SIGN		DATE					
		AUDITING		DATE					
MARKER	MODIFY	FILE NO	SIGNATURE	DATE	APPROV	DATE			

49

CUSTOMER	CUSTOMER APPROVAL	CUST PART NO.	AL-TS12(0)
		SECTION NO.	285891

a=0.1r
b=0.2r
c=0.3r
d=0.4r
e=0.5r
f=0.8r

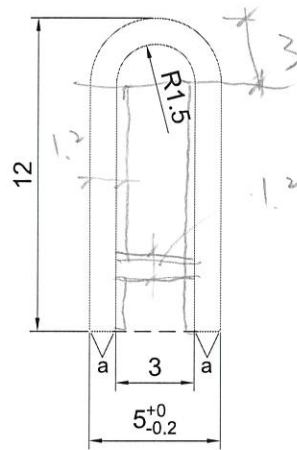

SCALE 4:1

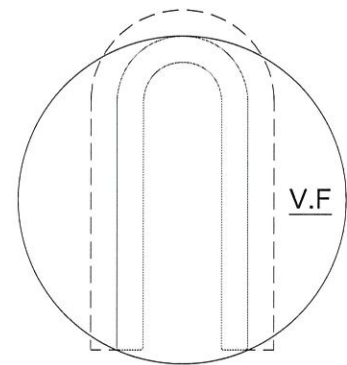

SCALE 1:1

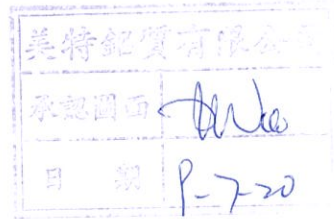

SIGNATURE GRADEING	HIGH SIGNATURE GRADEING	C.C.DIA(MM)	50.08						
AREA (SQ MM)	25.27	UNSPECIFIED THICKNESS	1.0	PERIMETER (MM)	52.39	STANDARD		SCALE	1:1
MASS (KG/M)	0.068	UNSPECIFIED CORNERS	-	SURFACE AREA	26.97	ALLOY	6063-T6	VERSION	
COMPANY ISSUE			DRAWN	LHR	DATE	2020-02-29	APELLATION	PAGE OF	
			STANDARDIZATION		DATE		 美特鋁質有限公司 MIDI Aluminium Fabricator Ltd.		
			TO SIGN		DATE				
			AUDITING		DATE				
MARKER	MODIFY	FILE NO	SIGNATURE	DATE	APPROV	DATE			

50