

工程指示 / 要求簡箋(E.I.)

工程指示編號：EI / 1525 / 20 修改版次：

工程編號：J - 852 工程名稱：亞皆老街中電

工程項目：Show Flat 後加工程 - 隔音吊趟訂料 (廠用)

收件人：Maggie / 生統 / 進華哥 發件人：Bessie Lau 日期：20/02/2020

要求提供 / 確認 事項：

- | | | |
|------------------------------------|-------------------------------------|-------------------------------|
| <input type="checkbox"/> 初步鋁料 B.M. | <input type="checkbox"/> 加工拆圖，然後生產 | <input type="checkbox"/> 尺寸表 |
| <input type="checkbox"/> 正式鋁料 B.M. | <input type="checkbox"/> 技術上資料 / 指示 | <input type="checkbox"/> 報價 |
| <input type="checkbox"/> 配件 B.M. | <input type="checkbox"/> 樣辦或貨品說明書 | <input type="checkbox"/> 分判合約 |
| <input type="checkbox"/> 其他：_____ | | |

內容：

煩請按此訂購隔音吊趟料送廠，辦房用：

1. Flat C Living Room 露台用 (現場已做單趟，現改為雙趟)

2. Flat A BR1 用 (本來是雙趟，現場把雙趟二合一改為臨時單趟，現須訂料做單趟)

請在 27/2/2020 前完成上列要求。

敬用

附有關圖紙 / 文件：

以上項目為：

原合約工程包 原合約工程加 / 減賬 新工程報價

原因：-

分發東莞各部門：

- | | | | | | | | |
|---------------------------------|------------------------------|---|------------------------------|------------------------------|------------------------------|---|------------------------------|
| <input type="checkbox"/> 生產技術總監 | <input type="checkbox"/> 連附件 | <input type="checkbox"/> 技術部 | <input type="checkbox"/> 連附件 | <input type="checkbox"/> 生產部 | <input type="checkbox"/> 連附件 | <input type="checkbox"/> 機械設計部 | <input type="checkbox"/> 連附件 |
| <input type="checkbox"/> 採購部 | <input type="checkbox"/> 連附件 | <input checked="" type="checkbox"/> 生產統籌部 | <input type="checkbox"/> 連附件 | | | | |
| <input type="checkbox"/> 質檢部 | <input type="checkbox"/> 連附件 | <input type="checkbox"/> 會計部 | <input type="checkbox"/> 連附件 | <input type="checkbox"/> 報關組 | <input type="checkbox"/> 連附件 | <input checked="" type="checkbox"/> 其他 <u>陳進華</u> | <input type="checkbox"/> 連附件 |

分發香港各部門：

- | | | | | | | | |
|---|------------------------------|-------------------------------|------------------------------|------------------------------|------------------------------|-----------------------------------|------------------------------|
| <input type="checkbox"/> 行政部 | <input type="checkbox"/> 連附件 | <input type="checkbox"/> 會計部 | <input type="checkbox"/> 連附件 | <input type="checkbox"/> 統籌部 | <input type="checkbox"/> 連附件 | <input type="checkbox"/> 工程部地盤科文 | <input type="checkbox"/> 連附件 |
| <input checked="" type="checkbox"/> 採購部 | <input type="checkbox"/> 連附件 | <input type="checkbox"/> QS 部 | <input type="checkbox"/> 連附件 | <input type="checkbox"/> 維修部 | <input type="checkbox"/> 連附件 | <input type="checkbox"/> 其他 _____ | <input type="checkbox"/> 連附件 |

傳遞編號：

HK 0189 / 20

發件人簽署：

項目經理簽署：

SALES CONTRACT

**ARCHITECTURAL
ACOUSTICS**
LIMITED



SALES CONTRACT NO: Q8574 (Rev.1)
PLEASE USE THIS NUMBER ON ALL PURCHASE ORDER, LETTER OF CREDIT AND BILLS OF LADING

DATE:	20-Feb-20	PROPOSED SHIPMENT:	PACKING:	EXPIRY DATE:	21-Mar-20
TO:	Midi Aluminium Fabricator Ltd. Unit 6, 7, 8, Sunray Industrial Ctr, 1/F, 810 Cha Kwo Ling Road, Yau Tong, Kowloon		TERMS OF PAYMENT:		
ATTN:	Marco Tam		100% payment upon confirmation of order		
TEL:			REMARK:	CATEGORY:	
Email:	Midi@midi.com.hk				
DESCRIPTION		QUANTITY	PRICE	PER	AMOUNT
RE: <u>阿曾老街</u>			HKD		HKD
To provide acoustics material as follows: * Micro-perforated Plate is protected by Hong Kong Reg. Design No. 1900026.6M002-5/ 1913166.7/ 1913193.3/ 1913191.9/ 1913192.1/ Short Term Patent No. HK1229143/ HK1229144					
Item 1)	Description: - To prepare Shop Drawing. - To provide Materials of Acoustics Window (Baffle Type) including Alum. Extrusion in mill finish, Sound Absorptive Material, Gasket & Seals, 1.5-3mm Transparent Micro-Perforated Plate MPP, Angle Bracket, a pair of wheel & 3m guide rail.				
	Size: 811 x 2501 mm 1128 x 2501 mm	→ Flat C Living 用 (單軌變雙軌) 2 → Flat A BR1 用 (雙軌變單軌) 1	\$7,800 \$8,500	no no	\$15,600 \$8,500
Exclude: Glass, PVF2, cutting and assembly. Remarks: For 1800mm width panel, Perforation Area at Corner only.					
Item 2)	Description: Delivery to Dongguan ✓		1	\$2,000	no \$2,000
Remarks: 1. Please notice the terms and conditions of sales are on the next page. 2. It is the client's responsibility to ensure the above goods are suitability and certified for their application or requirement.					
TOTAL: -					HK\$26,100

It is understood that the terms and conditions set forth on the reverse side of this form are part of the terms and conditions of any sale between the parties and are to be regarded as binding and as legal conditions.

ACCEPTED & CONFIRMED BY:

ARCHITECTURAL ACOUSTICS LIMITED

BY: Elektra Wang - Project Coordinator
PERSON-IN-CHARGE



APPROVED: Mors Leung - Technical Manager
GENERAL MANAGER

AUTHORIZED SIGNATURE(S) & COMPANY CHOP

DISTRIBUTION: ORIGINAL - VENDOR COPY / PINK - FILE COPY / YELLOW - FINANCE COPY
 2/F., PO CHEONG COMM. BLDG., 29 PRAT AVENUE, TSIMSHATSUI, HONG KONG.
 TEL: (852) 2367 3232 FAX: (852) 2724 8001

此頁雙面影印。

General Terms & Conditions of Sale

1. When the price quoted on the front hereof its:
 - (a) "C.I.F." the price shall include cost, freight, and insurance only as at the date of contract, any fluctuations in freight or insurance to be for Buyer(s) account. Duty and all landing, customs, wharfage and other charges are to be paid by Buyer(s). The goods shall be at the exclusive risk of the Buyers as from the date of shipment.
 - (b) "F.O.B. Port of shipment." Buyer(s) agree to pay all charges for freight and insurance, which latter shall be effected as provided in Clause 7 hereof. The goods shall be at the exclusive risk of the Buyers as from the date of shipment.
 - (c) "Plus charges." Buyer(s) agree to pay all the charges for packing, forwarding including rail charges, lighterage, port dues, and other incidental expenses, shipping freight and insurance, which latter shall be effected as provided in Clause 7 hereof.
 - (d) "Ex godown".....the price shall include cost and all expenses in delivering the goods at Seller's godown and Buyer(s) agree to take delivery Sellers go down and to pay the cost of removal therefrom.
2. It shall be optional for Sellers or their principals to refuse or delay delivery under this contract should any money due in respect of any draft or promote or on any other account whatsoever not having been paid when due, and such non-payment on Buyer(s) part shall entitle Seller or their Principals to cancel this contract without notice to Buyer(s) or to enforce its terms at their option.
3. If Seller' Principals refuse to execute the order contained herein and the refusal be communicated to Buyer(s) within 60days from the date hereof, the contract shall be deemed to be cancelled.
4. In case of Buyer(s)' Insolvency pending the performance of this contract by him/them, Sellers have the option either to cancel the contract or so much thereof as shall not have been performed or to re-sell the goods to Buyer(s) account without any notice to Buyer(s).
5. Notice from one party to the other shall have been deemed to have been duly served if left at the other's last known place of business of Posted under registered cover addressed to such place.
6. Buyer(s) agree in all cases to be bound and abide by the conditions of the Bill of Lading. In case Buyer(s) shall request or Sellers shall think fit, Buyer(s) will accept Delivery Orders in lieu of the Bill or Bills of Lading and such Delivery Orders shall in all respects be deemed valid shipping documents equivalent to the relative Bills of Lading and treated as such. Neither Sellers nor their Principals are to be under any obligation either to see that the goods comprised in such Delivery Orders have been duly landed or otherwise howsoever, Buyer's rights and remedies in respect of short delivery, damage or other claims being against the ship or underwriters only.
7. Marine insurance effected by Sellers or their Principals shall be without their guaranteeing the solvency of the insurance Company with which such insurance if effected, and in the event of any claim arising against the underwriters, Sellers or their Principals have absolute discretion to settle the same on Buyer's behalf as Sellers or their Principals may think fit. Loss or injury to any part of the goods shall not entitle Buyer(s) to refuse the remainder and in the event of any loss or injury to any part of machine which machine when complete consists of several parts, the Underwriters are to be liable only for the insured value of the part thus lost or injured.
8. In the event of this contract relating to the goods delivery of which is to be made in more than one installment this contract shall be deemed and construed as a separate contract in respect of each installment and the right and liabilities of both parties respectively shall be as though a separate contract had been made for each installment, provided that this shall not in any way affect Seller's or their Principals' right to withhold delivery under the conditions of clause 2.
9. In the case of running orders for a stated periodical supply of goods should Buyer(s) fail to take delivery of any periodical supply within the specified time, it shall be deemed to come within the conditions of clause 2, 4, 20 & 24, and be dealt with accordingly.
10. Buyer(s) must understand that the illustrations in Sellers' or their Principals' catalogue are intended as a guide only and that the details may to the size of the article or on account of improvements or alternations in manufacture.
11. The Buyers will be responsible if the performance by the Sellers of any stipulation as to the marking or packing of the goods shall constitute an offence under the Merchandise Marks Act or the Merchandise Marks Ordinance and will indemnify the Sellers in respect of any such offence committed by them.
12. Neither Sellers nor their Principals are to be responsible for errors in telegrams or facsimile.
13. Any writing upon this document in any other language but English beyond Buyer(s) signature shall be of no effect.
14. Buyer(g) agree that the word "Month" in this contract or in any correspondence relative thereto is understood to mean a Calendar month according to the British Calendar.
15. Erection of Machines. Where Sellers contract to supervise erection of Machines, it shall be understood that all necessary coolie labor, lifting or hoisting tackle, material for foundations, or supports, etc, shall be supplied and paid for by Buyer(s). Where machines are supplied with electric motors, the necessary belting electric wiring, etc, shall be arranged and paid for by Buyer(s). Where machines are supplied without motors or other mechanical power drive, all necessary arrangements for motive power shall also be made by Buyer(s) and paid for by Buyer(s).
16. Where goods are sold or orders taken, in credit terms, Sellers reserve the right to require Cash against delivery.
17. Goods not cleared or paid for within due date to be at Buyers' sole risk and expense.
18. The Sellers shall not be responsible for any delay in fulfilling or for the non-fulfillment of this contract cause by strikes, lockout, war, warlike operations, civil commotions. Government Prohibitions or restrictions or requisitions or any Government action of whatsoever nature, fire, flood, typhoons, Acts of God, Force Majeure or by any other incidents or circumstance beyond the control of the Sellers whether or not of a similar nature to the foregoing.
19. If the Sellers shall be prevented by any of the causes specified in Clause 18 from delivery any of the said goods at the time provided, then, at Sellers' discretion, either the contract for sales shall be annulled or the time provided for delivery of the said goods extended, to enable them to be shipped as soon as circumstances permit. If the Sellers shall be prevented by any of the foregoing causes from delivery part of such goods contract for sale of that part shall at Seller's discretion, either be annulled or the time provided for delivery of the said goods extended, to enable them to be shipped as soon as circumstances permit, but the Sellers shall deliver and the Buyers shall take such part of the said goods as the Sellers shall be able to deliver at the time fixed for delivery and the Buyers shall pay for the part delivered the same proportion of the price as the part delivered bears to the whole of the goods agreed to be sold.
20. If the Buyers shall fail to take delivery within 7 days of the arrival of the goods in Hong Kong or to make Payment or shall commit a breach of any clause hereof the Sellers may terminate this contract so far as it is unfulfilled (without prejudice to the Sellers rights to recover all moneys owing to them in respect of goods already delivered) and thereafter the Sellers may sell the goods or any balance of the goods and any loss sustained by the Sellers on such sales shall be made good forthwith by the Buyers to the seller.
21. Any additional expenses incurred as the result of any of the causes specified in paragraph 18 hereof shall borne by the Buyers.
22. The Seller may at their discretion insure against war risk and in the event of their so doing the cost thereof shall be borne by the Buyers but the Sellers shall be under no liability by reason of such insurance not having been effected.
23. No claim under this contract or in respect of the goods shall be made against the Sellers unless it is made in writing within seven days after the arrival of the goods in Hong Kong nor shall any such claim be made after delivery has been made and the goods have been removed by the Buyers of their agents from the place of delivery.
24. If the Buyers shall fail to take delivery of the goods within 7 days after the arrival of the goods in Hong Kong, and the Sellers do not sell the goods accordance with paragraph 20 hereof the Buyers shall pay to the Sellers interest at the rate of 8% per annum on the balance of the purchase price outstanding and shall also pay all godown hire, insurance and other charges payable in respect of the goods until the Buyers shall take delivery or until the Sellers shall re-sell, as the case may be but nothing herein contained shall operate to prevent the resale by the Sellers at any time after the said period of 7 days.
25. All orders are accepted subject to the availability of raw materials, and packages also to payment of the prices, duties, taxes and other charges ruling at the date of despatch, even if the orders are not despatched until after the expiry of the stipulated shipment period on the reverse side of this contract.
26. Unless specifically modified thereby all the above conditions shall apply and form part of all notices, amendments, appendices or correspondence in respect of this contract although not repeated or cited therein.
27. The Buyers are not at liberty to inspect any goods intended for them until after they have purchased the documents of title to the goods, Prior knowledge that the goods are not identical to those ordered does not entitle the Buyers to refuse to pay for the documents of title, or take up the goods. In such cases the documents of title must be paid for and the goods taken up by the Buyers, who are thereafter free to lodge a claim with the Sellers.
28. Architectural Acoustics Limited is referred to throughout this document as the Seller.
29. Installation/Erection of Works, where sellers contract to supervise installation/erection of works, it shall be understood that the followings shall be supplied and paid for by Buyer(s).
 - (a) Free availability of good lift during normal working hours (9:00 am to 5:30pm) for the vertical transportation of material, labour and equipment to respective floors involved in these contract.
 - (b) Free of charge to supply of electrical power for terminal points located an each floor available to Sellers for the operation of tools and equipment
 - (c) Free and unrestricted access to those areas in which work is to be installed. Building areas in which work is to be carried out shall be weather tight and free from water, debris or other items which would restrict or affect commencement of work, storage of materials and progress of installation.
 - (d) Free availability of dry and secure storage areas for storage of materials, etc.

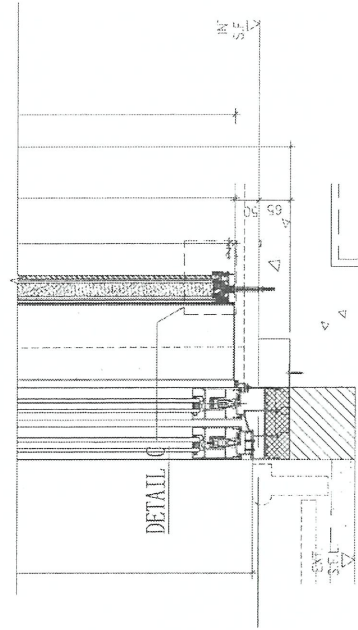
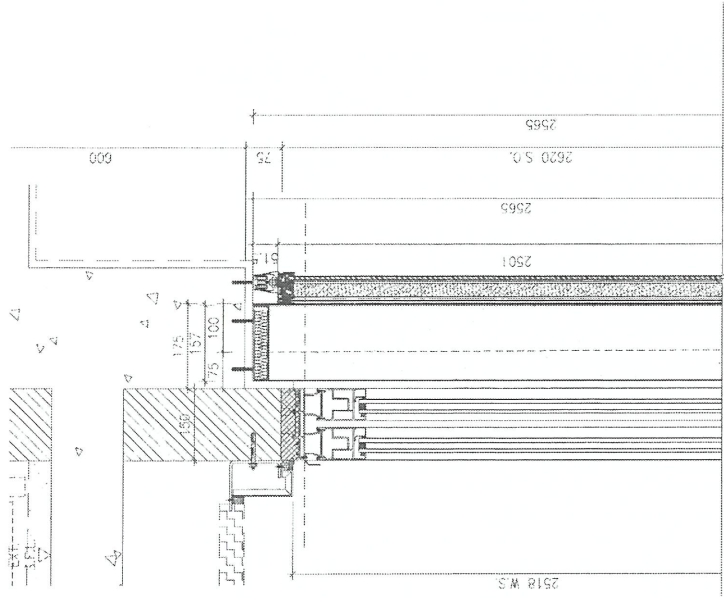

2 SECTION
1:10

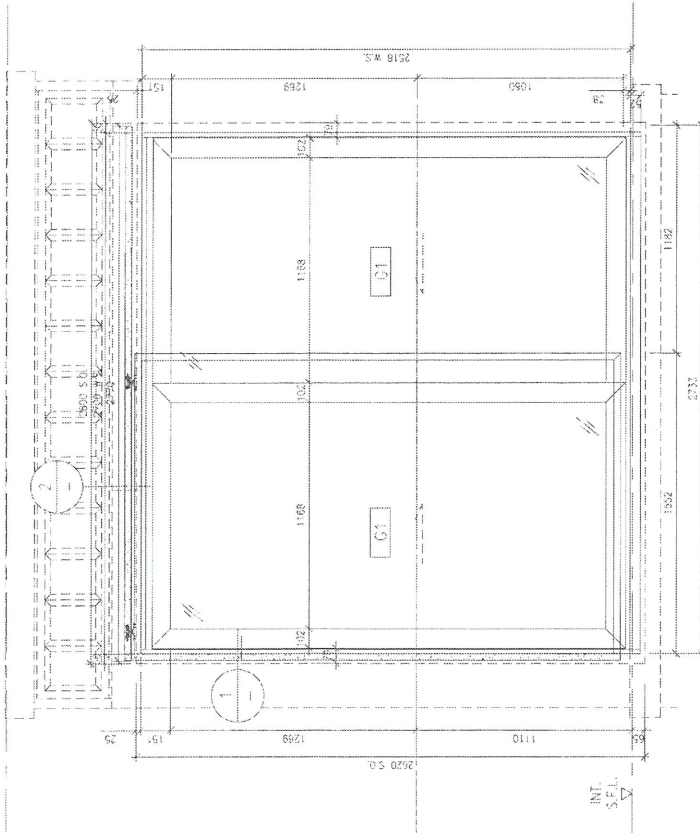

1 VIEW
1:25

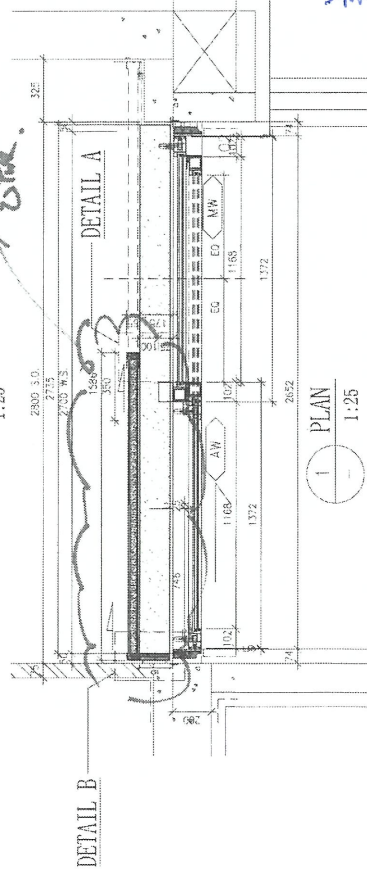

1 PLAN
1:25

新声店已做

所有尺寸必须在工地现场量度。图中尺寸大小以所注为依。不可用比例尺直接量度。本图研究其副本均为建筑声学有限公司之版权所有。翻印必究。

Rev	修訂	Date	日期	备注	Rev	修訂	Date	日期	备注
A									
B									
C									
D									

Title 项目		W1120-P W106-Unit C LIV.	
Drawing No. 图号		001B	
Job No. 工程编号		-	
Date 日期		2019-10-25	
Drawn 绘图		QING	
Scale 比例		A3	
Check 校核		Austin	
Rev 修订		B	
E-mail: sales@aa-hk.hk		852-27248001 852-23673232 852-27248001	

ARCHITECTURAL ACOUSTICS	
建筑声学	
CLP	

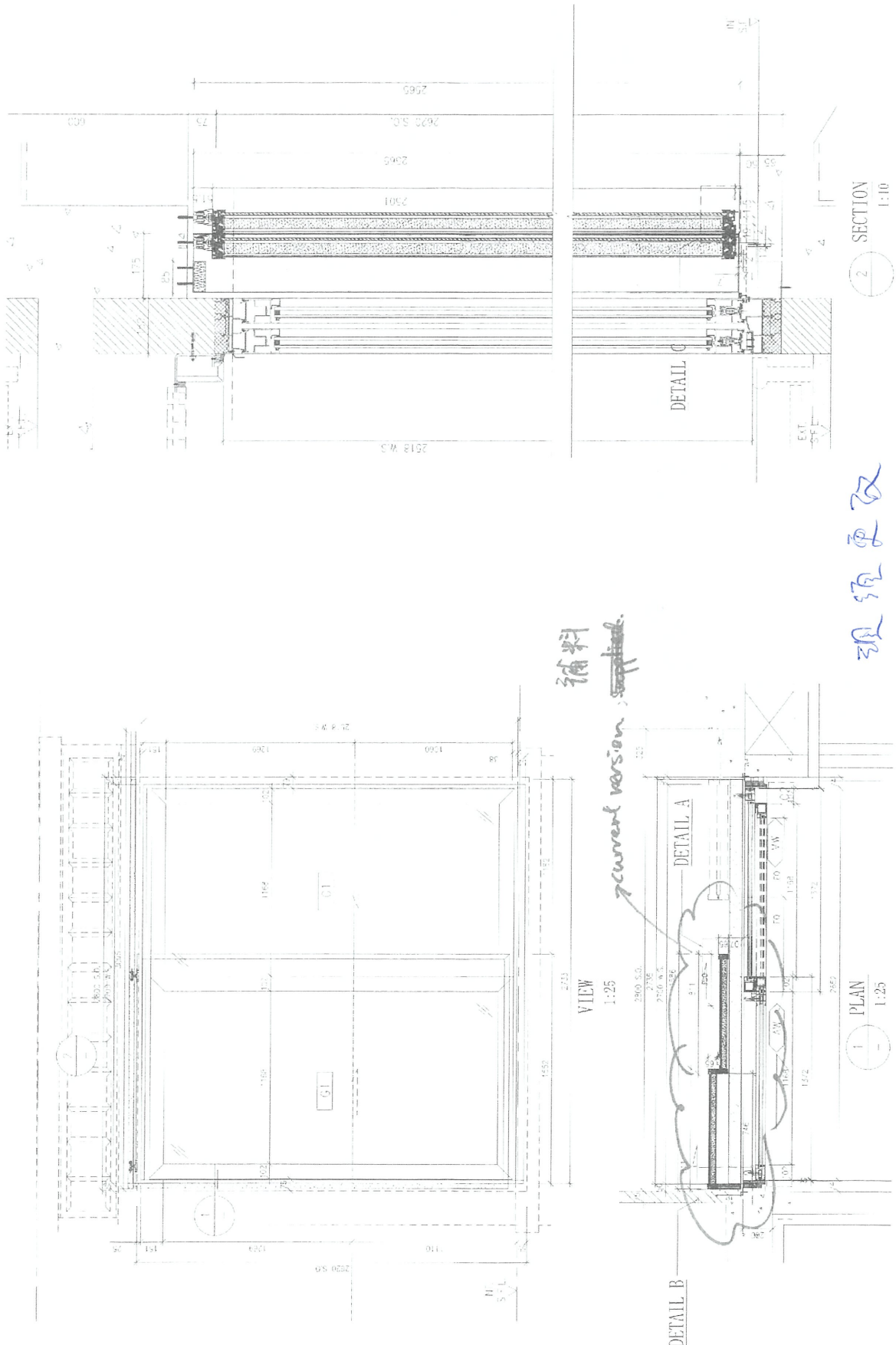

现场更改

所有尺寸必须在工地现场量度，图中尺寸大小以所注为依，不可用比例尺直接量度。本图纸及其副本为建筑声学有限公司之版权所有，翻印必究。

Rev	修订	Date	备注	Date	修订	备注	Project	工程名称
A								
B								
C								
D								

Title 项目		W1120-P W106-Unit C LIV.	
Drawing No. 图号		001B	
Job No. 工程编号		-	
Date 日期		2020-1-21	
Drawn 绘图		01NG	
Scale 比例		A3	
Check 校核		Austin	
Rev 修订		C	

CLP

ARCHITECTURAL ACOUSTICS

建筑声学

地址：香港尖沙咀车路旁29号高昌商业大厦二楼 电话：852-23673332 传真：852-27748001 E-mail: sales@ap-hk.hk

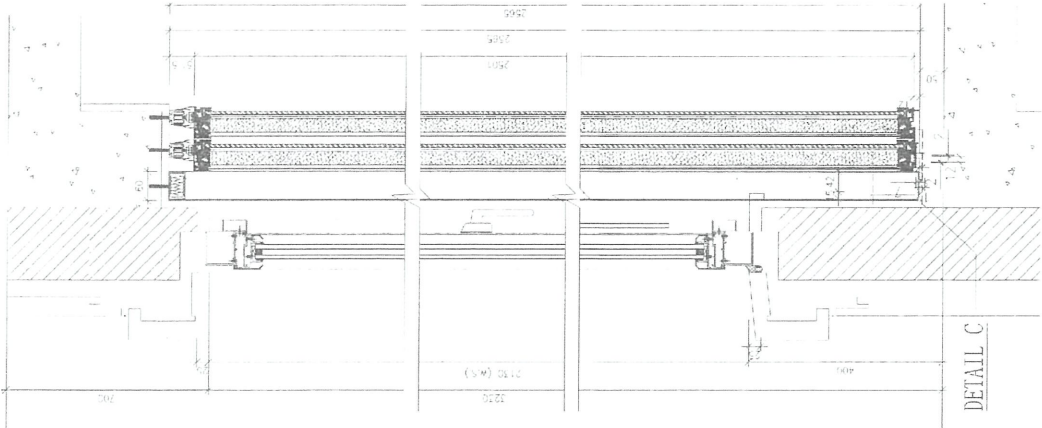

SECTION
1:10

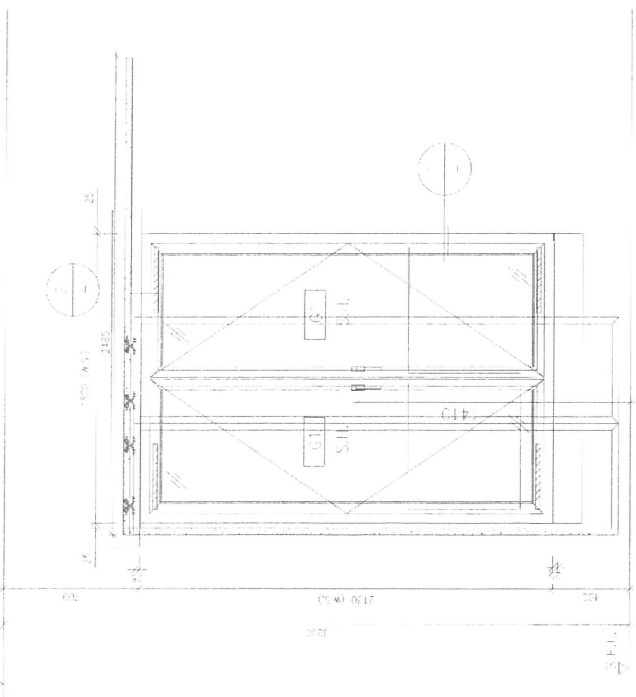

VIEW
1:25

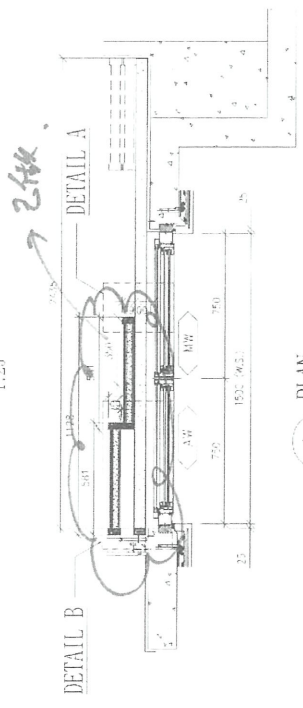

PLAN
1:25

已做
詳情已做

所有尺寸必须在工地现场量度。图中尺寸大小以所注为依，不可用比例尺直接量度。本图及其副本均为建筑声学有限公司之版权所有，翻印必究。

Rev	修订	Date	日期	备注	Project	工程名称
A					CLP	
B						
C						
D						

Drawing No. 图号	005	Job No. 工程编号	-	Date 日期	2019-10-16
Drawn 绘图	QING	Check 校核	Austin	Scale 比例	A3
Rev 修订	A	Rev 修订	A	Rev 修订	A

Title 项目
W1102-P W107-Unit A, B, R, I

ARCHITECTURAL ACOUSTICS
建筑声学

地址：香港尖沙咀宝勒巷29号宝皇商业大厦二楼 电话：862-27248001 传真：862-27248001 E-mail: sales@aa-hk.com

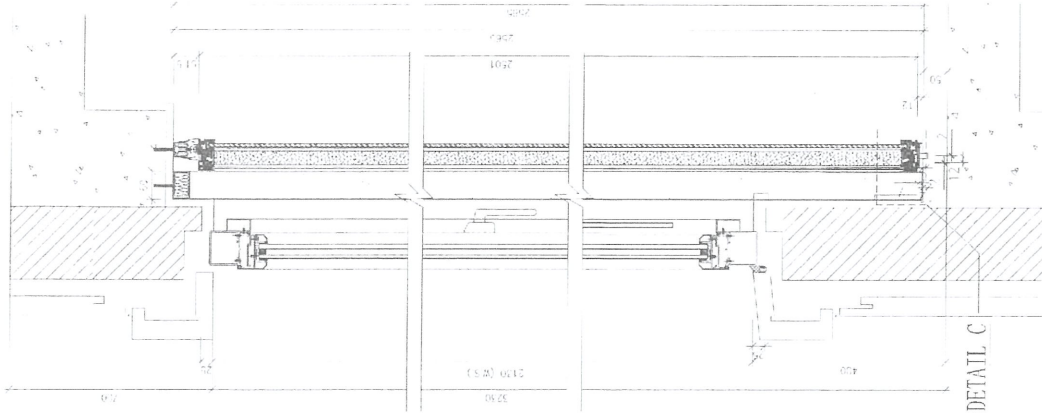

2 SECTION
1:10

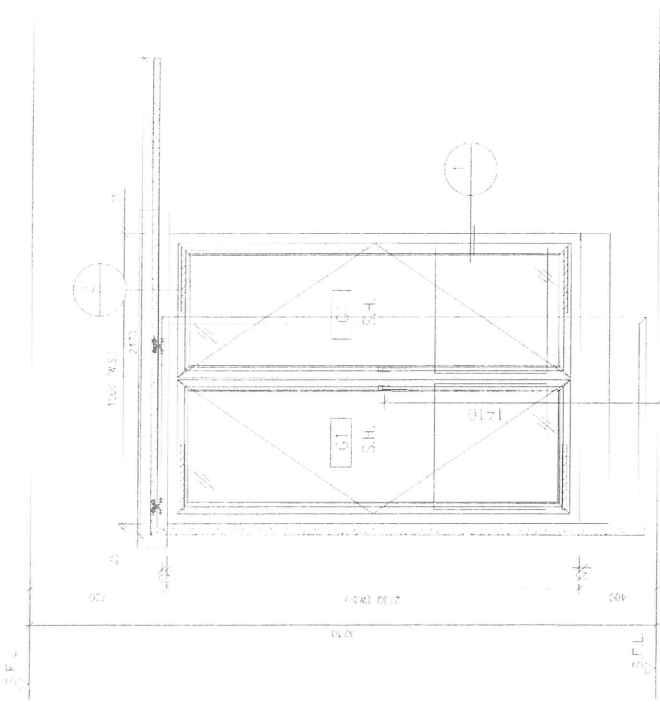

VIEW
1:25

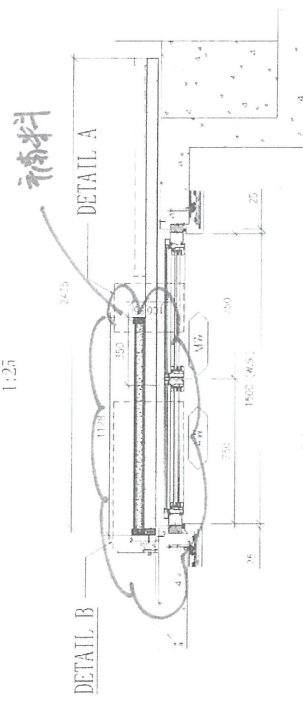

1 PLAN
1:25

現經更改

所有尺寸必須在工地現場量度。圖中尺寸大小以所注為依據，不可用比例尺直接量度。本圖紙及其圖本均為建築聲學有限公司之版式所有，翻印必究。

Rev	修訂	Date	日期	Note	備註	Rev	修訂	Date	日期	Note	備註	Project	工程名稱
A													
B													
C													
D													

Title 項目
W1102-P W107-Luit A B.R. I

ARCHITECTURAL ACOUSTICS
建築聲學

Drawing No. 圖號	005
Job No. 工程編號	-
Date 日期	2020-02-04
Drawn 繪圖	QJING
Scale 比例	A3
Check 校核	Austin
Rev 修訂	B

地址：香港尖沙咀彌敦道29號皇昌商業大廈二樓 電話：867-2367232 傳真：867-27748001 E-mail: sales@aa-inc.hk