

工程指示 / 要求簡箋(E.I.)

工程指示編號：EI / 1636 / 20

修改版次：-

工程編號：J851

工程名稱：青衣 明翹匯

工程項目：繪畫模圖 (鋁飾綫)

收件人：羅小姐

發件人：Leung Hin Wai

日期：27/03/2020

要求提供 / 確認 事項：

- | | | |
|------------------------------------|-------------------------------------|-------------------------------|
| <input type="checkbox"/> 初步鋁料 B.M. | <input type="checkbox"/> 加工拆圖，然後生產 | <input type="checkbox"/> 尺寸表 |
| <input type="checkbox"/> 正式鋁料 B.M. | <input type="checkbox"/> 技術上資料 / 指示 | <input type="checkbox"/> 報價 |
| <input type="checkbox"/> 配件 B.M. | <input type="checkbox"/> 樣辦或貨品說明書 | <input type="checkbox"/> 分判合約 |
| <input type="checkbox"/> 其他：_____ | | |

內容：

繪畫模圖。共 7 頁。

請在_____前完成上列要求。

附有關圖紙 / 文件：-

以上項目為：

- 原合約工程包 原合約工程加 / 減賬 新工程報價

原因：-

分發東莞各部門：

- () 生產技術總監 連附件 () 技術部 連附件 () 生產部 連附件 () 機械設計部 連附件
 () 採購部 連附件 () 生產統籌部 連附件
 () 質檢部 連附件 () 會計部 連附件 () 報關組 連附件 () 其他 _____ 連附件

分發香港各部門：

- () 行政部 連附件 () 會計部 連附件 () 統籌部 連附件 () 工程部地盤科文 連附件
 () 採購部 連附件 () QS 部 連附件 () 維修部 連附件 () 其他 _____ 連附件

傳遞編號：

HRK0448

發件人簽署：

項目經理簽署：



MIDI ALUMINIUM FABRICATOR LTD.

DRAWING NO.
X85812

REV.
-

TITLE
企鋁飾線A

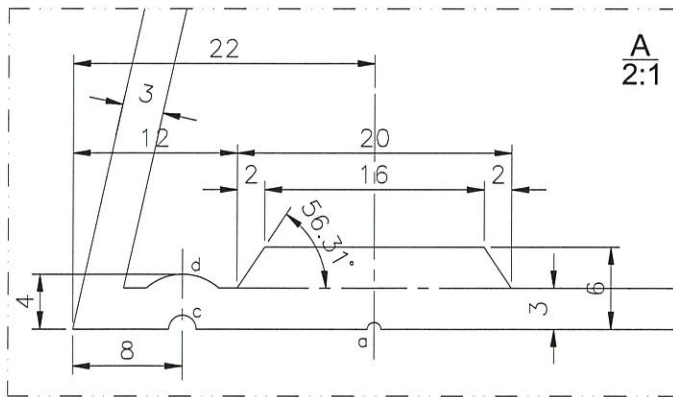
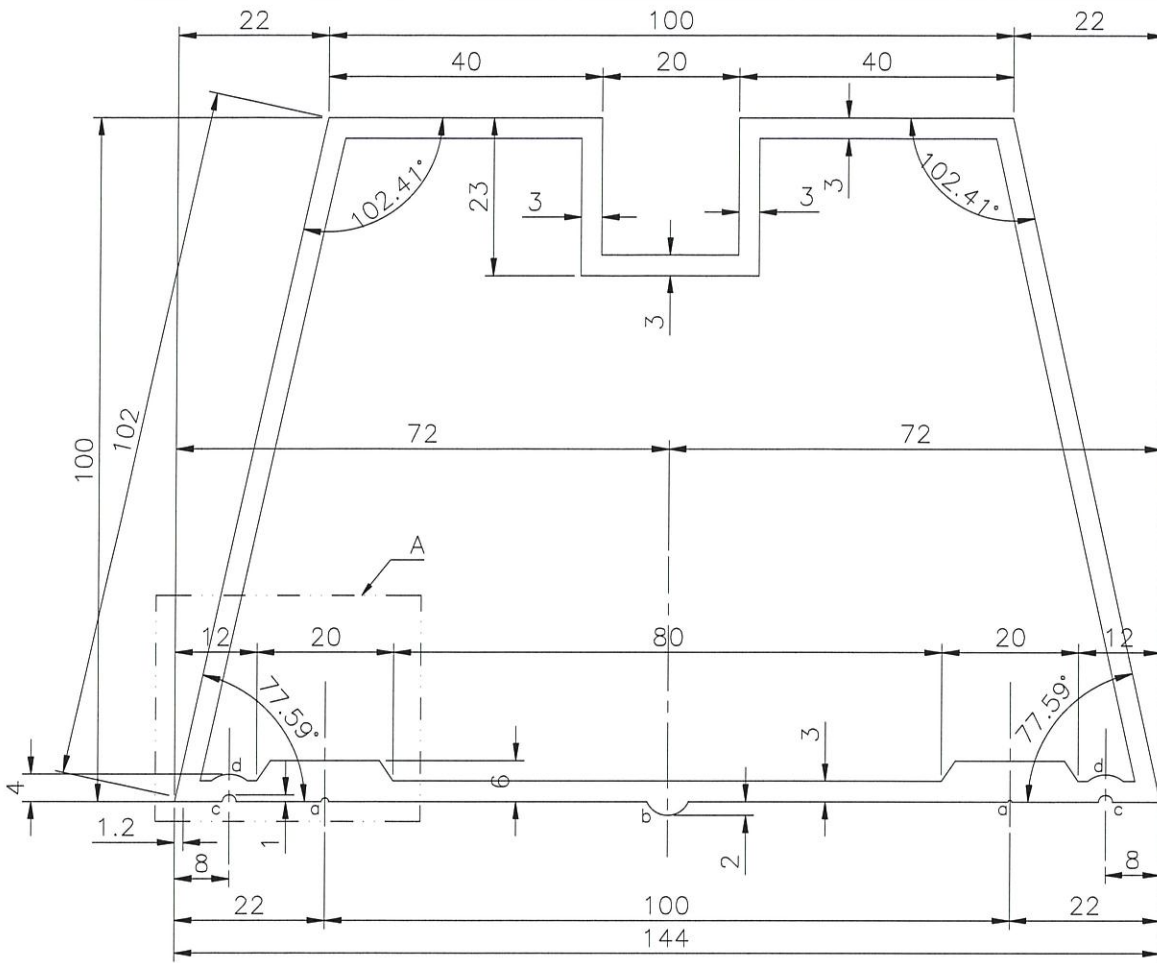

a=R0.3
b=R3.25
c=R1
d=R4

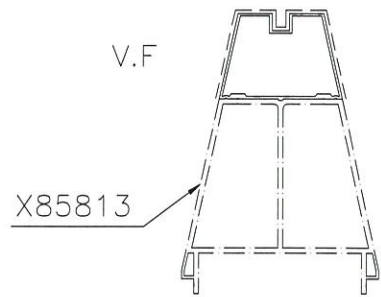

SCALE 1:4

APPROVED :

6063-T5

NOTE: Unspecified thickness _____ mm
Radii on unspecified corner (max. 0.3 mm)

SECTIONAL AREA		ADDITIONAL TOLERANCE		DATE	REVISION	
1546.52	mm ²	Thickness	± 0.1	04/01/2020	NO.	DATE
WEIGHT	KG/M	Flatness	0.1 /25mm width	SCALE	DESCRIPTION	
4.19		Straightness	0.3 /300mm	1 : 1	承認圖面	
PERIMETER	mm	Twist	0.5° /300 mm max	DRAWN	日期 21/3-2020	
961.96		Angularity	± 1.0 degree	CHECK		
V.F.	mm					
344.78						

 MIDI ALUMINIUM FABRICATOR LTD.	DRAWING NO. X85813	REV. —	TITLE 企鋁飾線B
---	------------------------------	------------------	-----------------------

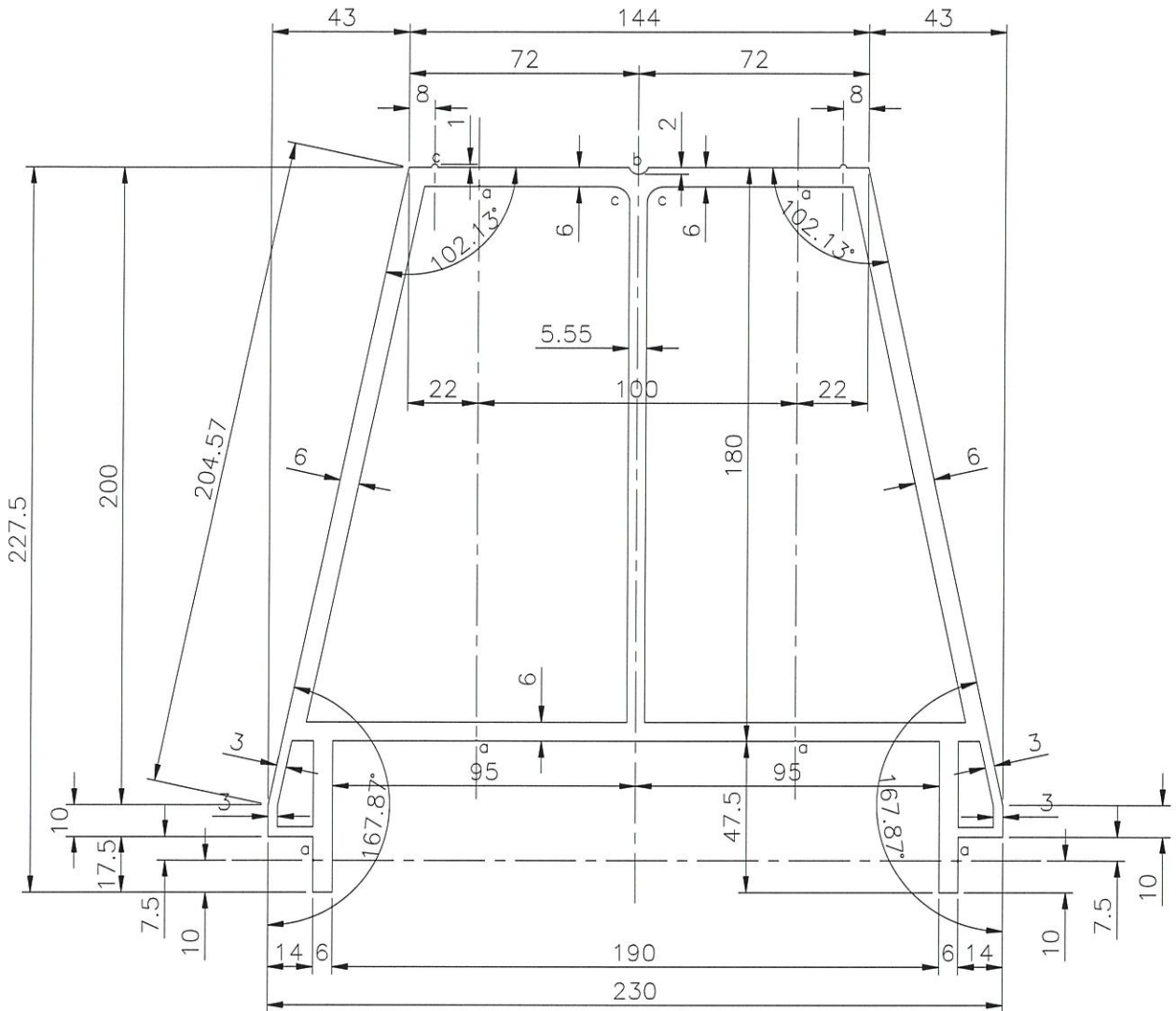

a=R0.3
b=R3.25
c=R1

美特鋁質有限公司

承認圖面	
日期	27/3-2020

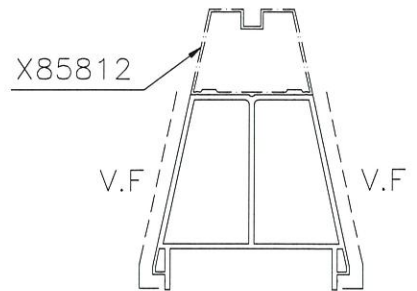

SCALE 1:8

NOTE: Unspecified thickness _____ mm
Radii on unspecified corner (max. 0.3 mm)

APPROVED :

6063-T5

SECTIONAL AREA mm ² 6009.38	ADDITIONAL TOLERANCE Thickness ± 0.1 mm	DATE 04/01/2020	REVISION			
WEIGHT KG/M 16.29	Flatness 0.1 /25mm width	SCALE 1 : 2	NO.	DATE	NAME	DESCRIPTION
PERIMETER mm 2087.77	Straightness 0.3 /300mm	DRAWN -				
V.F. mm 457.14	Twist 0.5° /300 mm max Angularity ± 1.0 degree	CHECK				



MIDI ALUMINIUM FABRICATOR LTD.

DRAWING NO.
X85814

REV.
-

TITLE
企鋁飾線C

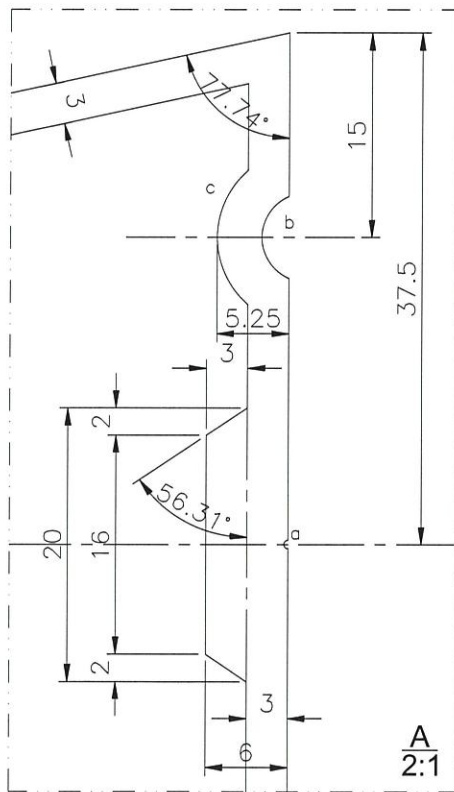
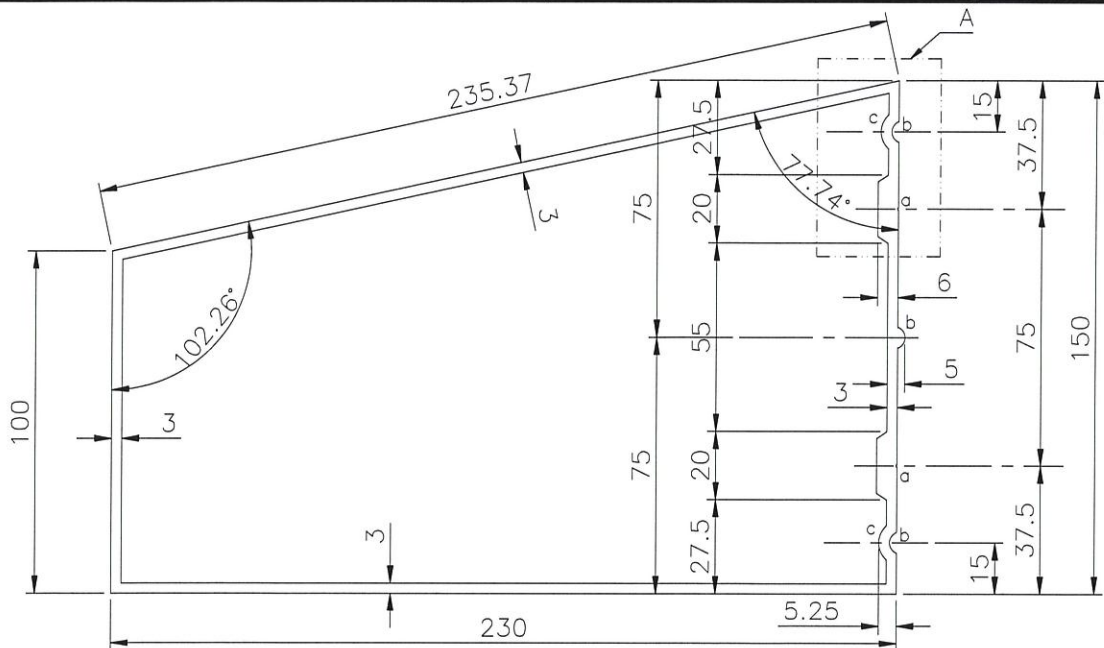

a=R0.3
b=R3.25
c=R6.5

美特鋁質有限公司
承認圖面
日期 27/3-2020

X85815

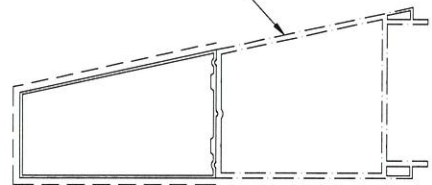

V.F

SCALE 1:8

APPROVED :

6063-T5

NOTE: Unspecified thickness _____ mm.
Radii on unspecified corner (max. 0.3 mm)

SECTIONAL AREA	mm ²	ADDITIONAL TOLERANCE	DATE	REVISION			
				NO.	DATE	NAME	DESCRIPTION
2239.45		Thickness ± 0.1 mm	04/01/2020				
WEIGHT	KG/M	Flatness 0.1 /25mm width	SCALE				
6.07		Straightness 0.3 /300mm	1 : 2				
PERIMETER	mm	Twist 0.5° /300 mm max	DRAWN				
1421.14		Angularity ± 1.0 degree	-				
V.F.	mm		CHECK				
567.11							

 MIDI ALUMINIUM FABRICATOR LTD.	DRAWING NO. X85815	REV. -	TITLE 企鋁飾線D
---	------------------------------	------------------	-----------------------

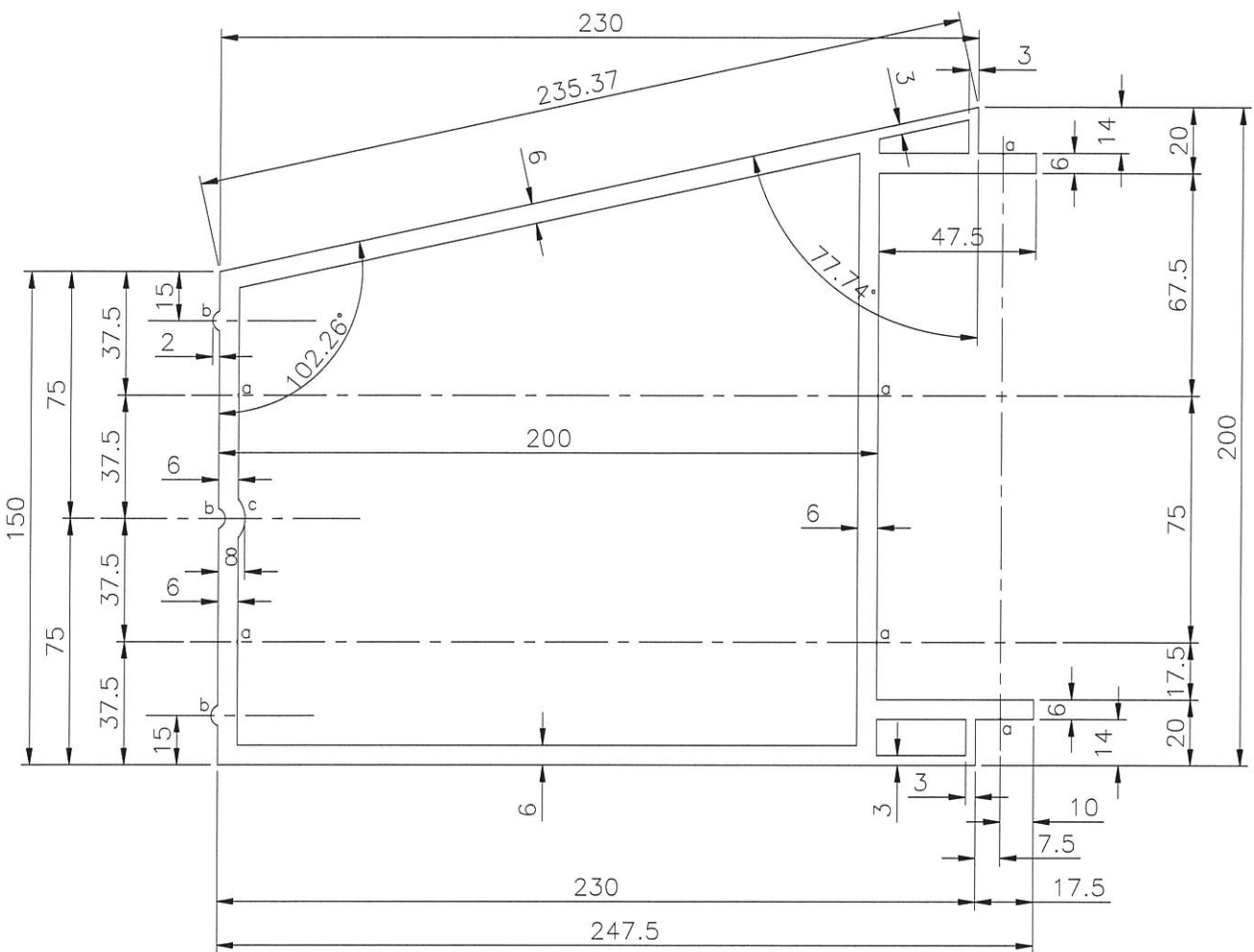

a=R0.3
b=R3.25
c=R9.25

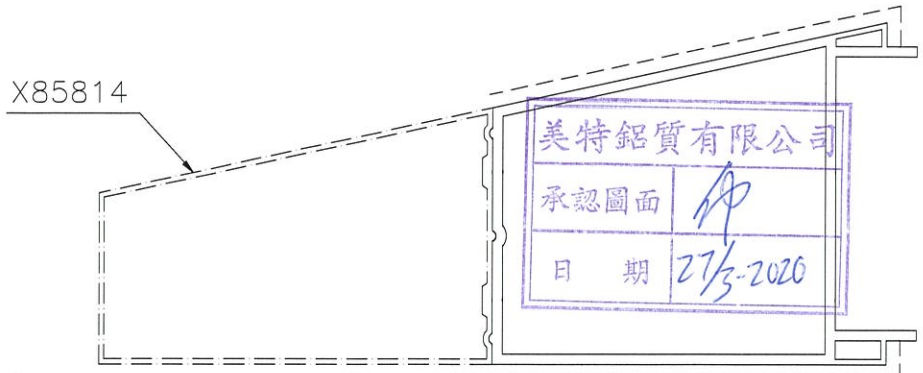

APPROVED :

6063-T5

SCALE 1:4

NOTE: Unspecified thickness _____ mm
Radii on unspecified corner (max. 0.3 mm)

SECTIONAL AREA mm ² 5182.97	ADDITIONAL TOLERANCE Thickness ± 0.1 mm	DATE 04/01/2020	REVISION			
WEIGHT KG/M 14.04	Flatness 0.1 /25mm width	SCALE 1 : 2	NO.	DATE	NAME	DESCRIPTION
PERIMETER mm 1798.17	Straightness 0.3 /300mm	DRAWN -				
V.F. mm 493.37	Twist 0.5° /300 mm max Angularity ± 1.0 degree	CHECK				

	MIDI ALUMINIUM FABRICATOR LTD.	DRAWING NO. X85816	REV. -	TITLE 企鋁飾線E
--	--------------------------------	-----------------------	-----------	----------------

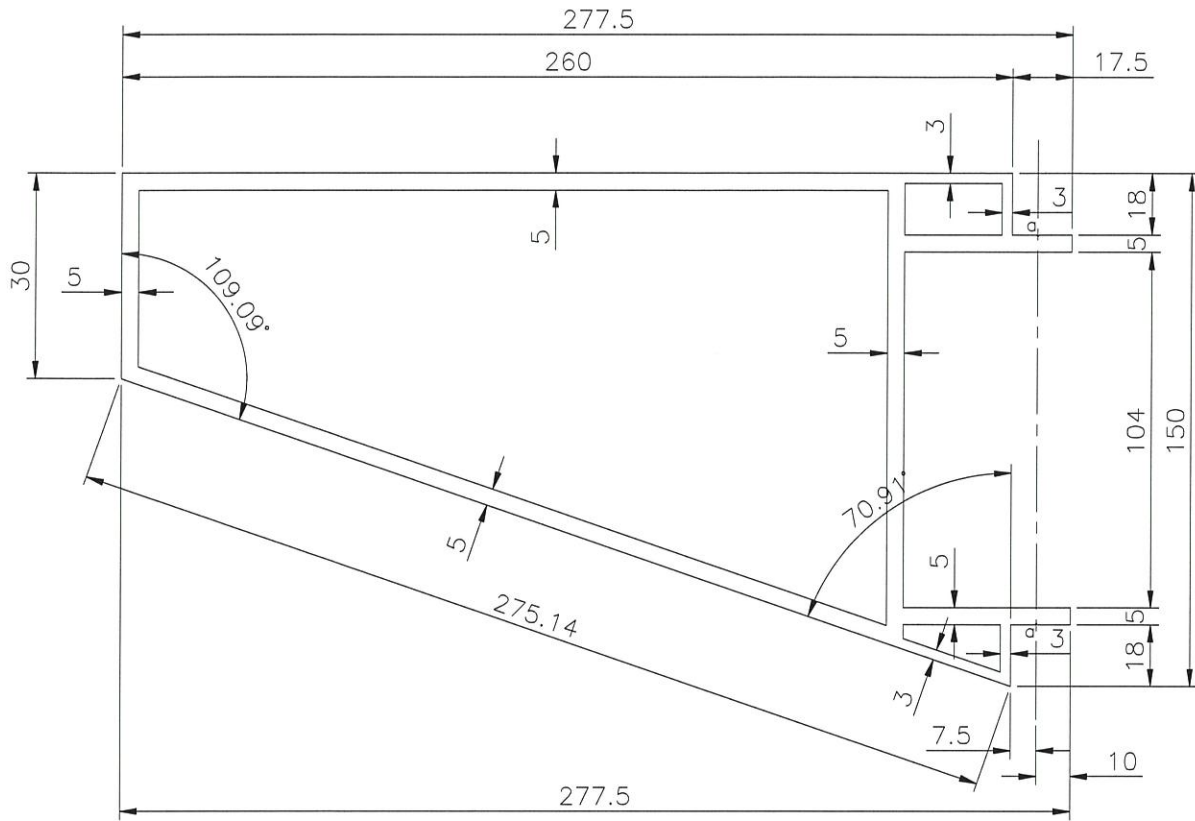

美特鋁質有限公司
承認圖面
日期 21/3-2020

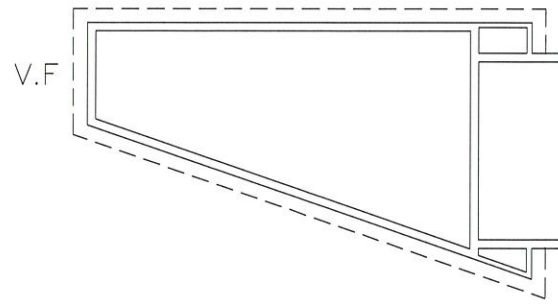

a=R0.3

SCALE 1:4

APPROVED :

6063-T5

NOTE: Unspecified thickness _____ mm
Radii on unspecified corner (max. 0.3 mm)

SECTIONAL AREA	mm ²	ADDITIONAL TOLERANCE	DATE	REVISION			
				NO.	DATE	NAME	DESCRIPTION
4014.7		Thickness ± 0.1 mm	04/01/2020				
WEIGHT	KG/M	Flatness 0.1 /25mm width	SCALE				
10.88		Straightness 0.3 /300mm	1 : 2				
PERIMETER	mm	Twist 0.5° /300 mm max	DRAWN				
1669.9		Angularity ± 1.0 degree	-				
V.F.	mm		CHECK				
631.14							



MIDI ALUMINIUM FABRICATOR LTD.

DRAWING NO.
X85817

REV.
-

TITLE
欄河鋁飾線A

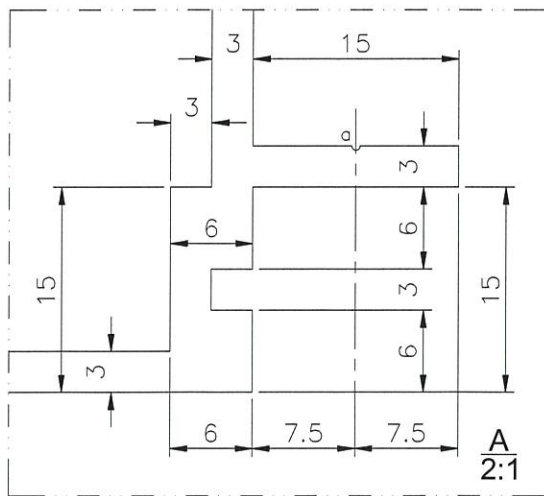
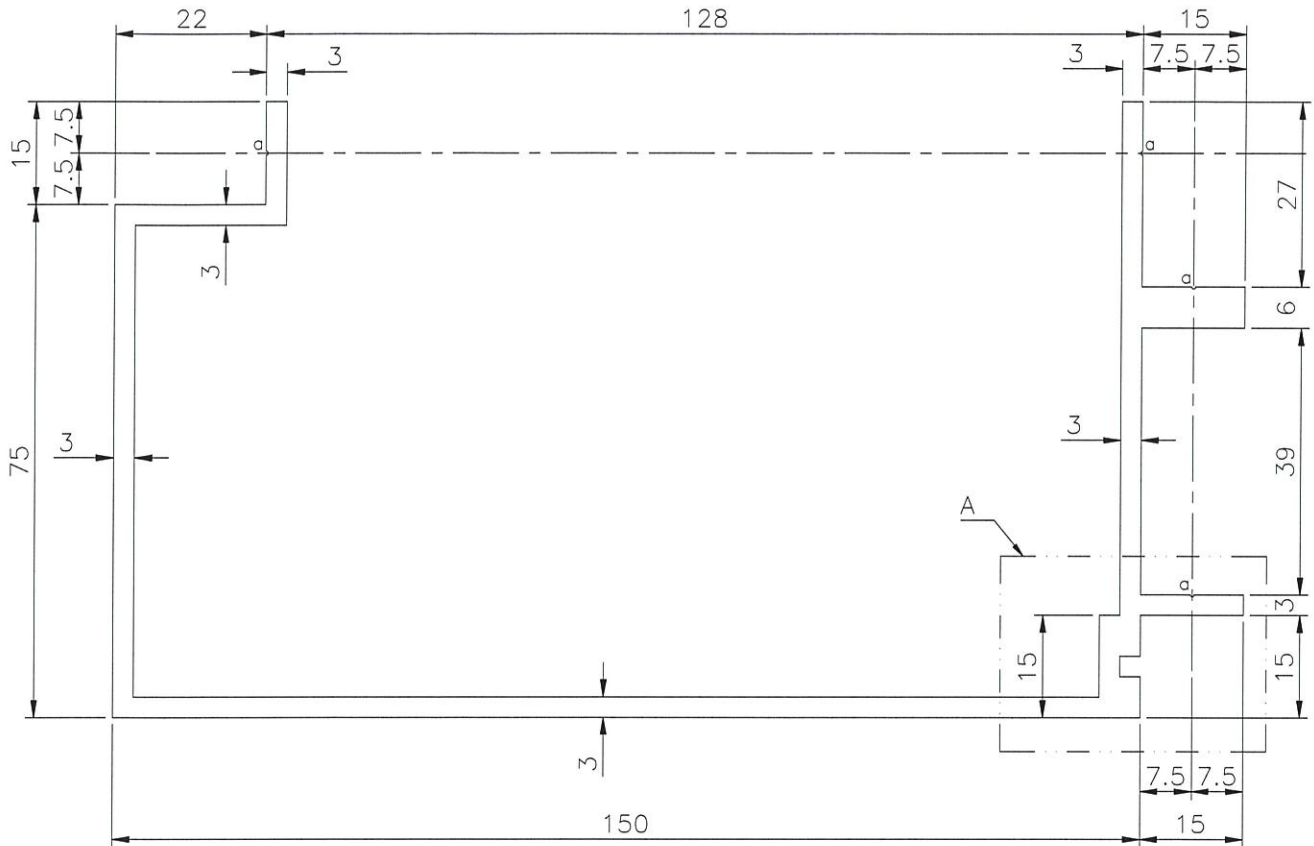

美特鋁質有限公司
承認圖面
日期 27/3-2020

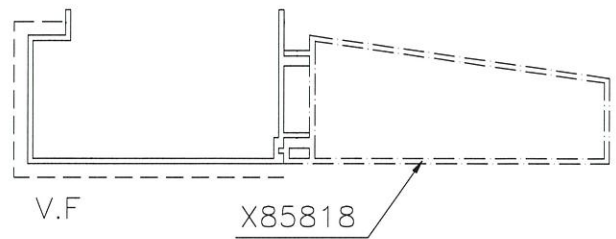

SCALE 1:2

APPROVED :

6063-T5

NOTE: Unspecified thickness _____ mm
Radii on unspecified corner (max. 0.3 mm)

SECTIONAL AREA	mm ²	ADDITIONAL TOLERANCE	DATE	REVISION			
				NO.	DATE	NAME	DESCRIPTION
1154.41		Thickness ± 0.1 mm	04/01/2020				
WEIGHT	KG/M	Flatness 0.1 /25mm width	SCALE				
3.13		Straightness 0.3 /300mm	1 : 1				
PERIMETER	mm	Twist 0.5° /300 mm max	DRAWN				
765.36		Angularity ± 1.0 degree	-				
V.F.	mm		CHECK				
247							

