

工程指示 / 要求簡箋(E.I.)

工程指示編號：EI/ 1532 /20

修改版次：

工程編號：J851

工程名稱：青衣明翹滙

工程項目：

大貨佛沙窗 對照編號圖表

收件人：

生統

發件人：

Joe Chan

日期：25/2/202

要求提供 / 確認 事項：

- | | | |
|------------------------------------|-------------------------------------|-------------------------------|
| <input type="checkbox"/> 初步鋁料 B.M. | <input type="checkbox"/> 加工拆圖，然後生產 | <input type="checkbox"/> 尺寸表 |
| <input type="checkbox"/> 正式鋁料 B.M. | <input type="checkbox"/> 技術上資料 / 指示 | <input type="checkbox"/> 報價 |
| <input type="checkbox"/> 配件 B.M. | <input type="checkbox"/> 樣辦或貨品說明書 | <input type="checkbox"/> 分判合約 |
| <input type="checkbox"/> 其他：_____ | | |

內容：

附上佛沙窗對照編號圖表，生產佛沙窗時請先參考附件圖表，以確認同一款式鋁窗數量。

請在 _____ 前完成上列要求。

附有關圖紙 / 文件：

1 + 16頁

以上項目為：

- 原合約工程包 原合約工程加 / 減賬 新工程報價

原因：-

分發東莞各部門：

- () 生產技術總監 連附件 () 技術部 連附件 () 生產部 連附件 () 機械設計部 連附件
 () 採購部 連附件 (✓) 生產統籌部 連附件 軍
 (✓) 質檢部 連附件 () 會計部 連附件 () 報關組 連附件 (✓) 其他 王良 連附件

分發香港各部門：

- () 行政部 連附件 () 會計部 連附件 () 統籌部 連附件 () 工程部地盤科文 連附件
 () 採購部 連附件 () QS 部 連附件 () 維修部 連附件 () 其他 _____ 連附件

傳遞編號：

HK 0216 / 20

發件人簽署：

項目經理簽署：

P.P.

3

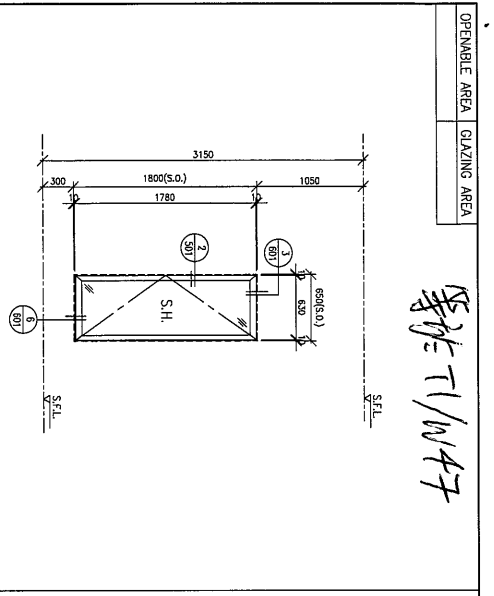

等於 T1/W4

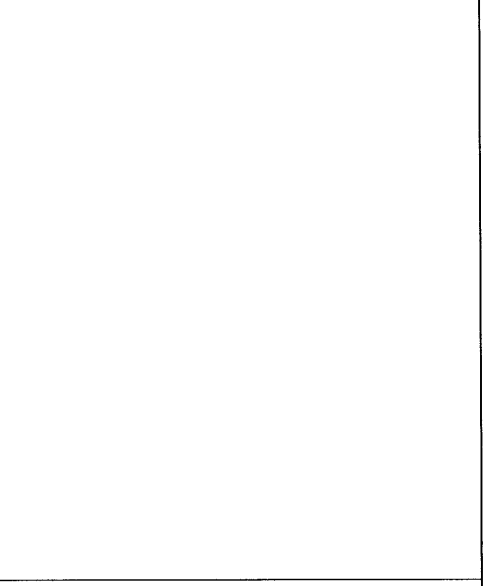

等於 T1/W3

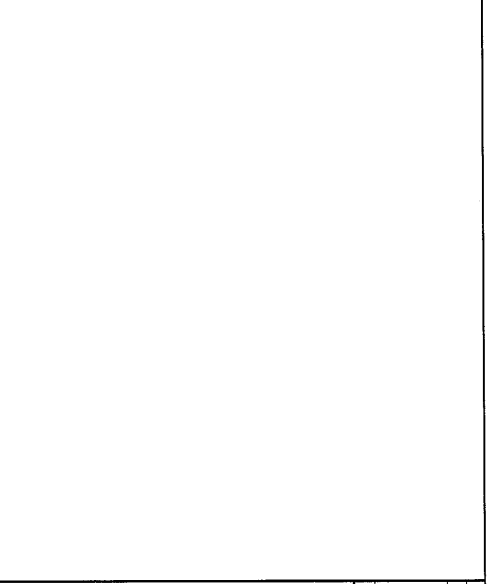

等於 T1/W4

WINDOW MARK	W1/4 27 nos.		
LOCATION	T1 LOBBY CORRIDOR (1-3)/F. 413,414,417 (UNITED)		
GLAZING	GL08	FRAME	AL11
REMARK	65mm ALUM. WINDOW SECTION		
FREE AREA(%)	OPENABLE AREA	GLAZING AREA	1.57%

WINDOW MARK	W1/3 2 nos.		
LOCATION	T1A FLAT C BRG. (2F-33/F)		
GLAZING	GL02	FRAME	AL11
REMARK	65mm ALUM. WINDOW SECTION		

WINDOW MARK	W1/4 2 nos.		
LOCATION	T1A FLAT C BRG. (2F-33/F)		
GLAZING	GL02	FRAME	AL11
REMARK	65mm ALUM. WINDOW SECTION		

BD. REF :
FSO. REF :
NOTE :
1. All dimensions are in mm.
2. All dimensions are shown from outside unless otherwise stated.
3. All dimensions to be verified on site before fabrication.
GENERAL NOTES
Legend :
1. F.F.L. --- Finished Floor Level
2. S.F.L. --- Structural Floor Level
3. (Symbol) --- Removal Point
X1-1 --- OPENABLE MARK NO.
X001 --- REFER SHEET NO.

CLIENT : 佳明集團控股有限公司
GRAND MING GROUP HOLDINGS LIMITED
MAIN CONTRACTOR : GRAND TECH CONSTRUCTION CO. LTD.
ARCHITECT : HONG TUNG & PARTNERS LIMITED
STRUCTURAL ENGINEERS : C M WONG & ASSOCIATES LTD.
PROJECT : RESIDENTIAL DEVELOPMENT AT TSIING YI TOWN LOT 191 SA SHAN ROAD

美特經貿有限公司
MIDI EASTERN HONGKONG LTD.
The S. G. Shing Building, 1/F
610-612, 614, 616, 618, 620, 622, 624, 626, 628, 630, 632, 634, 636, 638, 640, 642, 644, 646, 648, 650, 652, 654, 656, 658, 660, 662, 664, 666, 668, 670, 672, 674, 676, 678, 680, 682, 684, 686, 688, 690, 692, 694, 696, 698, 700, 702, 704, 706, 708, 710, 712, 714, 716, 718, 720, 722, 724, 726, 728, 730, 732, 734, 736, 738, 740, 742, 744, 746, 748, 750, 752, 754, 756, 758, 760, 762, 764, 766, 768, 770, 772, 774, 776, 778, 780, 782, 784, 786, 788, 790, 792, 794, 796, 798, 800, 802, 804, 806, 808, 810, 812, 814, 816, 818, 820, 822, 824, 826, 828, 830, 832, 834, 836, 838, 840, 842, 844, 846, 848, 850, 852, 854, 856, 858, 860, 862, 864, 866, 868, 870, 872, 874, 876, 878, 880, 882, 884, 886, 888, 890, 892, 894, 896, 898, 900, 902, 904, 906, 908, 910, 912, 914, 916, 918, 920, 922, 924, 926, 928, 930, 932, 934, 936, 938, 940, 942, 944, 946, 948, 950, 952, 954, 956, 958, 960, 962, 964, 966, 968, 970, 972, 974, 976, 978, 980, 982, 984, 986, 988, 990, 992, 994, 996, 998, 1000
Tel: 23488211, Fax: (852) 27727856
JOB NO. : J-851
DRAWN BY : C.H.P. DATE : 20-11-2019
CHKD BY : SCALE : A3: 1/50
DWG. NO. : J851-SCH-103 REV. : B

5

FREE AREA(%)	OPENABLE AREA	GLAZING AREA	OPENABLE AREA	GLAZING AREA	OPENABLE AREA	GLAZING AREA	OPENABLE AREA	GLAZING AREA
57%								

WINDOW MARK	LOCATION	WINDOW MARK	LOCATION	WINDOW MARK	LOCATION
W44 T1 1 nos.	T1 Rm A STORE (32/15)	W45 T1 2 nos.	T1A LOBBY CORRIDOR (32-33/15)	W46 T1 4 nos.	T1 LOBBY CORRIDOR (32-33/15)

GLAZING	FRAME	GLAZING	FRAME	GLAZING	FRAME
GLO2	AL11	GLO8	AL11	GLO8	AL11

REMARK	REMARK	REMARK
65mm ALUM. WINDOW SECTION	65mm ALUM. WINDOW SECTION	65mm ALUM. WINDOW SECTION

OPENABLE AREA	GLAZING AREA	OPENABLE AREA	GLAZING AREA	OPENABLE AREA	GLAZING AREA
57%		57%		57%	

WINDOW MARK	LOCATION	WINDOW MARK	LOCATION	WINDOW MARK	LOCATION
W44 T1 2 nos.	T1 LOBBY CORRIDOR (32-33/15)	W45 T1 32 nos.	T1 Rm D MAINT. (2-31/15; 4.131V,2V/F DUNITD)	W46 T1 2 nos.	T1 Rm D MAINT. (32/15)

GLAZING	FRAME	GLAZING	FRAME	GLAZING	FRAME
GLO6	AL11	GLO6	AL11	GLO6	AL11

REMARK	REMARK	REMARK
65mm ALUM. WINDOW SECTION	65mm ALUM. WINDOW SECTION	65mm ALUM. WINDOW SECTION

OPENABLE AREA	GLAZING AREA	OPENABLE AREA	GLAZING AREA	OPENABLE AREA	GLAZING AREA
57%		57%		57%	

B.B. REF :
 F.S.O. REF :
 Note :
 1. All dimensions are in mm.
 2. All dimensions are taken from outside.
 3. All dimensions to be verified on site before ordering.
GENERAL NOTES
Legend
 1. F.F.L. — Finished Floor Level
 2. S.F.L. — Structural Floor Level
 3. H. — Reserved Height
 X1 — DETAIL MARK NO.
 X001 — REFER SHEET NO.

CLIENT :
 住明集團控股有限公司
 GRAND HING GROUP HOLDINGS LIMITED

MAIN CONTRACTOR :
 GRAND TECH CONSTRUCTION CO. LTD.

ARCHITECT :
 C M WONG & ASSOCIATES LTD.
 美特銘實有限公司
 MTDI Architecture & Interiors Ltd.
 Unit 8 & 8a, Sunny Industrial Centre, 1/F
 162-168B, 2/F
 Tel: (854) 2727565 Fax: (854) 2727566

STRUCTURAL ENGINEER :
 C M WONG & ASSOCIATES LTD.

PRODUCT :
 RESIDENTIAL DEVELOPMENT AT
 TSING YI TOWN LOT 190 SAI SHAN ROAD

TITLE :
 WINDOW SCHEDULE
 FOR PRECAST FACADE
 OF T1/T1A (S OF 6)

DRW NO. : J-851
 DRAWN BY : C.H.P. DATE : 30-11-2019
 CHD BY : SCALE : A1:1/30
 DMC NO. : JBS-SCH-105 REV. : 8

FREE AREA(%)	OPENABLE AREA	GLAZING AREA	FREE AREA(%)	OPENABLE AREA	GLAZING AREA	FREE AREA(%)	OPENABLE AREA	GLAZING AREA
{5.72%			{5.72%			{5.72%		

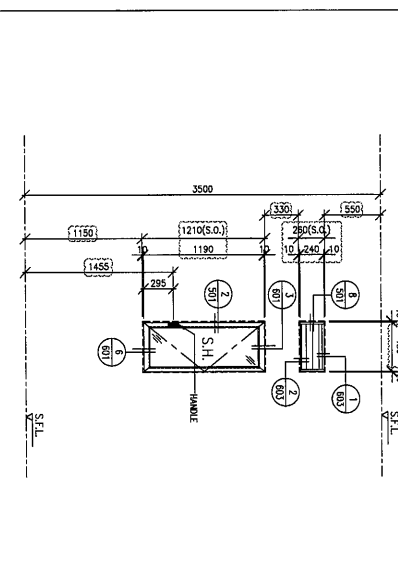
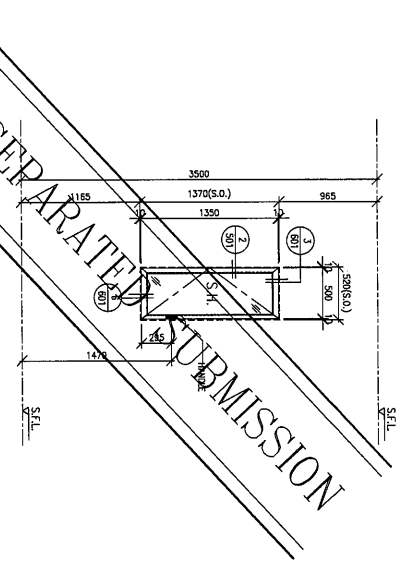
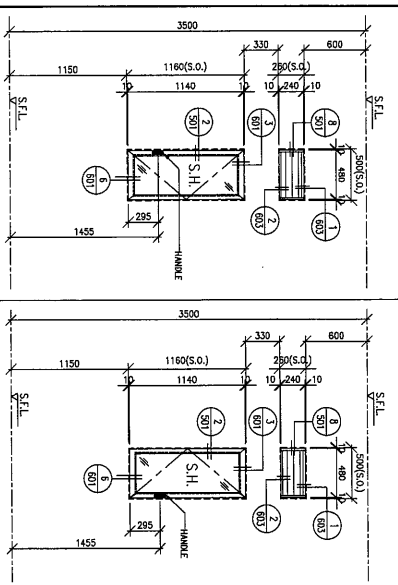

WINDOW MARK	W60	TT	2 nos.	TT	1 nos.	TT	1 nos.	
LOCATION	TT FLOOR UNIT ROOM (55/F)		TT FLOOR UNIT ROOM (55/F)		TT FLOOR UNIT ROOM (55/F)		TT FLOOR UNIT ROOM (55/F)	

GLAZING	GL06	FRAME	AL11	GLAZING	GL06	FRAME	AL11	GLAZING	GL06	FRAME	AL11
REMARK	65mm ALUM. WINDOW SECTION			REMARK	65mm ALUM. WINDOW SECTION			REMARK	65mm ALUM. WINDOW SECTION		
GLAZING AREA	{5.72%}			GLAZING AREA	{5.72%}			GLAZING AREA	{5.72%}		

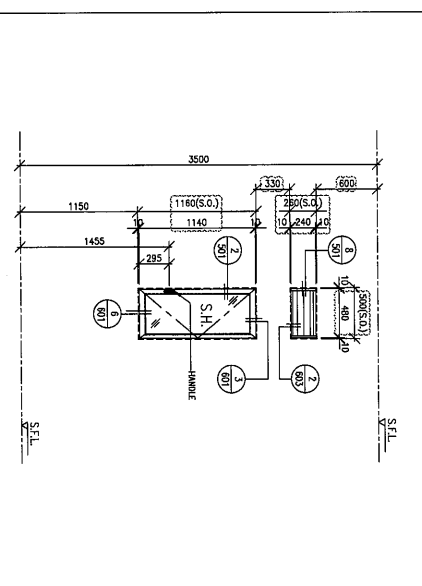
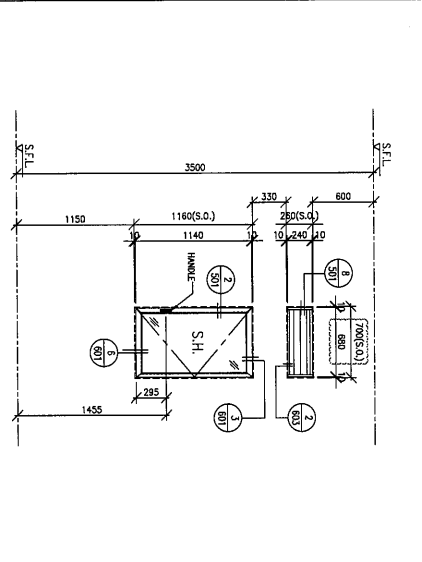
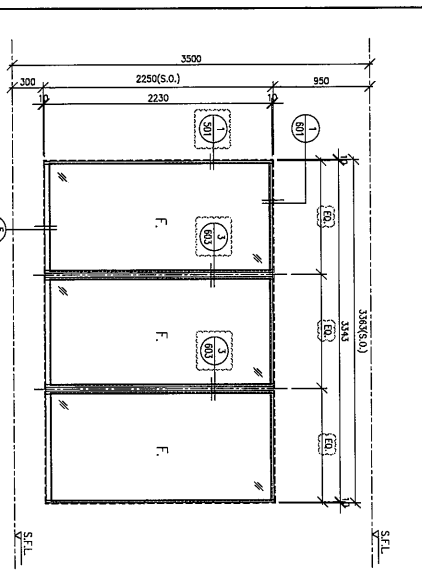

WINDOW MARK	W72	TT	1 nos.	WINDOW MARK	W72	TT	1 nos.	WINDOW MARK	W72	TT	2 nos.
LOCATION	TT FLOOR UNIT ROOM (55/F)		LOCATION	TT FLOOR UNIT ROOM (55/F)		LOCATION	TT FLOOR UNIT ROOM (55/F)		LOCATION	TT FLOOR UNIT ROOM (55/F)	
GLAZING	GL02	FRAME	AL11	GLAZING	GL06	FRAME	AL11	GLAZING	GL06	FRAME	AL11
REMARK	65mm ALUM. WINDOW SECTION			REMARK	65mm ALUM. WINDOW SECTION			REMARK	65mm ALUM. WINDOW SECTION		

B.D. REF :
F.S.O. REF :
Note :
1. All dimensions are in mm.
2. All elevations are viewed from outside.
3. All elevations to be verified on site before construction.
GENERAL NOTES

Legend :
1. F.F.L. — Finished floor level
2. S.F.L. — Structural floor level
3. F.F.L. — Finished floor level
X1 — DETAIL MARK NO.
X001 — REFER SHEET NO.

CLIENT : 住明集團控股有限公司
GRAND MING GROUP HOLDINGS LIMITED

MAIN CONTRACTOR : GRAND TECH CONSTRUCTION CO. LTD.

ARCHITECT : 美特銘實有限公司
M.T.M. ARCHITECTS & PLANNERS LIMITED

STRUCTURAL ENGINEER : C M WONG & ASSOCIATES LTD.

PROJECT : 美特銘實有限公司
M.T.M. ARCHITECTS & PLANNERS LIMITED
Units 6-8, Sunny Industrial Centre, 1/F
100, Yue Kwai Street, Tsim Sha Tsui, Kowloon
Tel: (852) 2727 9666 Fax: (852) 2727 9665

PRODUCT : RESIDENTIAL DEVELOPMENT AT
TSUNG YI TOWN LOT 198 SHA SHAN ROAD

TITLE : WINDOW SCHEDULE FOR PROPOSED FACADE OF T1/T1A (6 OF 6)

JOB NO. : J-851
DRAWN BY : C.H.P. DATE : 30-11-2019
CHKD BY : SCALE : A1:1/30
DWG. NO. : JBS-SCH-106 REV. : 8

7

FREE AREA(%) 57%	FREE AREA(%) 57%	FREE AREA(%) 57%
WINDOW MARK L23 29 nos.	WINDOW MARK L24 28 nos.	WINDOW MARK L26 28 nos.
LOCATION T1A BOUT C MARRI (-33/F; 4.13,14,24/F OMITTED)	LOCATION T1 BOUT A MTC (-32/F; 4.13,14,24/F OMITTED)	LOCATION T1 LBBBY CORRIDOR (-32/F; 4.13,14,24/F OMITTED)
GLAZING FRAME AL11	GLAZING FRAME AL11	GLAZING FRAME AL11
REMARK 65mm ALUM. WINDOW SECTION	REMARK 65mm ALUM. WINDOW SECTION	REMARK 65mm ALUM. WINDOW SECTION

	WINDOW MARK L27 29 nos.	WINDOW MARK L27 29 nos.	WINDOW MARK L27 29 nos.
LOCATION T1 BOUT C MARRI (-33/F; 4.13,14,24/F OMITTED)	LOCATION L27 29 nos.	LOCATION L27 29 nos.	LOCATION L27 29 nos.
GLAZING FRAME AL11	GLAZING FRAME AL11	GLAZING FRAME AL11	GLAZING FRAME AL11
REMARK 65mm ALUM. WINDOW SECTION	REMARK 65mm ALUM. WINDOW SECTION	REMARK 65mm ALUM. WINDOW SECTION	REMARK 65mm ALUM. WINDOW SECTION

WINDOW MARK L27 29 nos.	WINDOW MARK L27 29 nos.	WINDOW MARK L27 29 nos.	WINDOW MARK L27 29 nos.
LOCATION T1 BOUT C MARRI (-33/F; 4.13,14,24/F OMITTED)	LOCATION L27 29 nos.	LOCATION L27 29 nos.	LOCATION L27 29 nos.
GLAZING FRAME AL11	GLAZING FRAME AL11	GLAZING FRAME AL11	GLAZING FRAME AL11
REMARK 65mm ALUM. WINDOW SECTION	REMARK 65mm ALUM. WINDOW SECTION	REMARK 65mm ALUM. WINDOW SECTION	REMARK 65mm ALUM. WINDOW SECTION

R.S. REF :
F.S. REF :
Note :
1. All dimensions are in mm.
2. All dimensions are shown from outside.
3. All dimensions to be verified on site before construction.

GENERAL NOTES

Legend :
1. F.F.L.— Finished Floor Level
2. S.F.L.— Structural Floor Level
3. — Reserved Detail

X1 — DETAIL MARK NO.
X001 — REFER SHEET NO.

CLIENT :
佳明集團控股有限公司
GRAND MING GROUP HOLDINGS LIMITED

MAIN CONTRACTOR :
GRAND TECH CONSTRUCTION CO. LTD.

ARCHITECT :
WONG TUNG & PARTNERS LIMITED
ARCHITECTS & PLANNERS

STRUCTURAL ENGINEER :
C M WONG & ASSOCIATES LTD

PROJECT :
RESIDENTIAL DEVELOPMENT AT
TSING YI TOWN LOT 179 SHI SHAN ROAD

TITLE :
LOUVER SCHEDULE
FOR PRECAST FACADE
OF T1/T1A

JOB NO. : J-851
DRAWN BY : C.H.P. DATE : 20-11-2019
CHECK BY : SCALE : A1:1/30
DWG. NO. : 0851-SCH-107 REV. : 8

DATE : 06/12/2020
DRAWN BY : C.H.P.
CHECK BY :
DATE : 06/12/2020
DRAWN BY : C.H.P.
CHECK BY :
DATE : 06/12/2020
DRAWN BY : C.H.P.
CHECK BY :

8

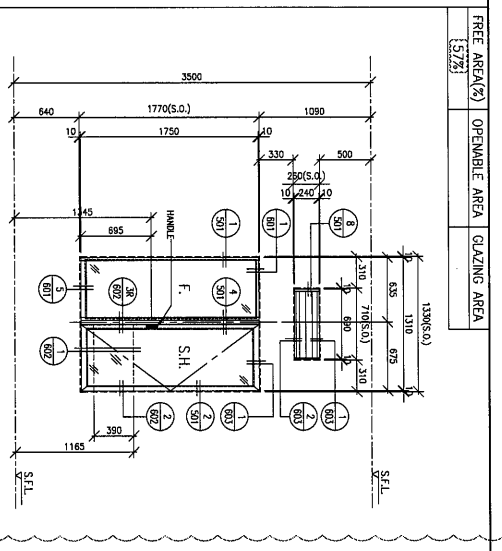
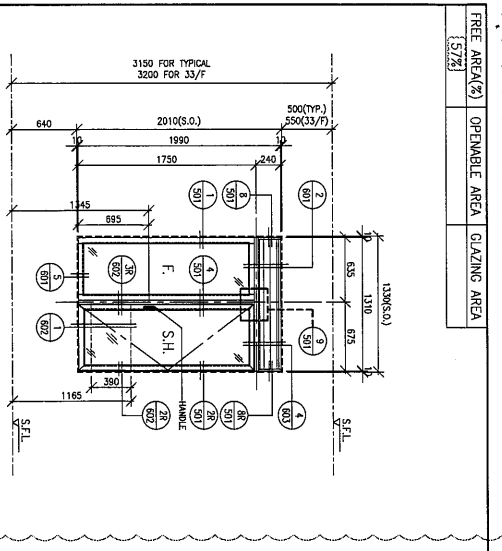

FREE AREA(%)	OPENABLE AREA	GLAZING AREA
157%		
WINDOW MARK		
LOCATION	T1A PART OF MBR. (1-31/F & 32/F : 4.13.14.24/F OMITTED) (1-30/F & 33/F : 4.13.14.24/F OMITTED)	
GLAZING	GLO2	FRAME AL11
REMARK	65mm ALUM. WINDOW SECTION	

FREE AREA(%)	OPENABLE AREA	GLAZING AREA
157%		
WINDOW MARK		
LOCATION	T1A PART OF MBR.(2/F) T1 PART OF MBR.(2/F)	
GLAZING	GLO2	FRAME AL11
REMARK	65mm ALUM. WINDOW SECTION	

BD. REF. :	
F.S.O. REF. :	
NOTE :	1. All dimensions are in mm. 2. All dimensions are viewed from outside. 3. All dimensions to be verified on site before fabrication.
GENERAL NOTES	
Legend :	1. F.F.A. — Finished Floor Level 2. S.F.L. — Structural Floor Level 3. () — Reserved Field
X1	DETAILED MARK NO.
X001	REFER SHEET NO.

CLIENT : 佳明集團控股有限公司
GRAND WING GROUP HOLDINGS LIMITED

MAIN CONTRACTOR : GRAND TECH CONSTRUCTION CO. LTD.

ARCHITECT : HONG TUNG & PARTNERS LIMITED
ARCHITECTS & PLANNERS

STRUCTURAL ENGINEER : C M WONG & ASSOCIATES LTD

13th Floor, Suning International Centre, 1/F
500 Nathan Road, Kowloon, HONG KONG
Tel: 23498211-4 Fax: (852) 2727855

PROJECT : RESIDENTIAL DEVELOPMENT AT
TUNG YI TOWN LOT 19A SA SHAN ROAD

TITLE : WINDOW SCHEDULE FOR PRECAST FACADE OF T1/T1A

JOB NO. : J-651

DRAWN BY : C.H.P. DATE : 20-11-2019

CHECK BY : SCALE: A3: 1/20

DOC. NO. : J851-SCH-101A REV. : -

10

窗於 T2/W4

FREE AREA(%)	GLAZING AREA	OPENABLE AREA	FREE AREA(%)	GLAZING AREA	OPENABLE AREA
57%			57%		

WINDOW MARK	W10	53 nos.	WINDOW MARK	W11	26 nos.
LOCATION	T2 FLAT A NORTH(2-3)/F. 4.13.14.24/F. (UNITED) T2 FLAT D NORTH(2-3)/F. 4.13.14.24/F. (UNITED)		LOCATION	T2 FLAT D NORTH(2-3)/F. 4.13.14.24/F. (UNITED)	
GLAZING	G106	FRAME AL11	GLAZING	G106	FRAME AL11
REMARK	65mm ALUM. WINDOW SECTION		REMARK	65mm ALUM. WINDOW SECTION	

WINDOW MARK	W15	27 nos.	WINDOW MARK	W16	52 nos.
LOCATION	T2A LABY CORRIDOR(2-3)/F. 4.13.14.24/F. (UNITED)		LOCATION	T2 LABY CORRIDOR(2-3)/F. 4.13.14.24/F. (UNITED)	
GLAZING	G108	FRAME AL11	GLAZING	G108	FRAME AL11
REMARK	65mm ALUM. WINDOW SECTION		REMARK	65mm ALUM. WINDOW SECTION	

WINDOW MARK	W13	52 nos.	WINDOW MARK	W13	52 nos.
LOCATION	T2 FLAT A NORTH(2-3)/F. 4.13.14.24/F. (UNITED) T2A FLAT A NORTH(2-3)/F. 4.13.14.24/F. (UNITED)		LOCATION	T2 FLAT A NORTH(2-3)/F. 4.13.14.24/F. (UNITED)	
GLAZING	G102	FRAME AL11	GLAZING	G102	FRAME AL11
REMARK	65mm ALUM. WINDOW SECTION		REMARK	65mm ALUM. WINDOW SECTION	

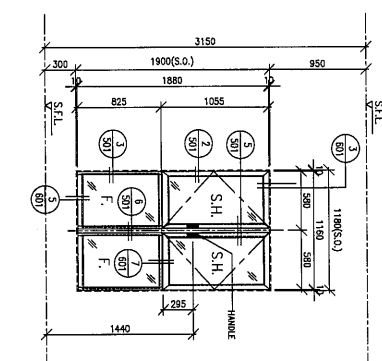
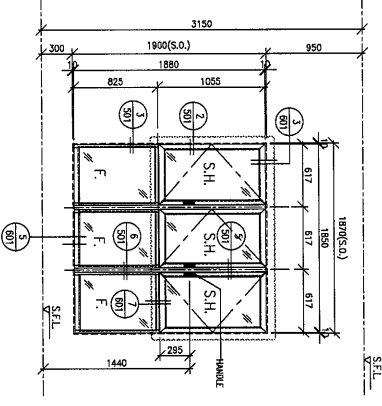
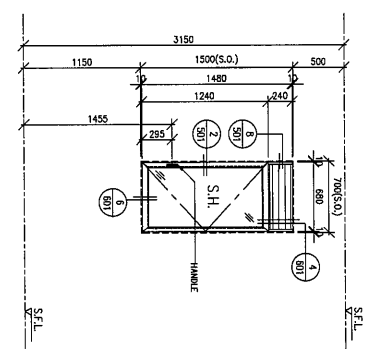
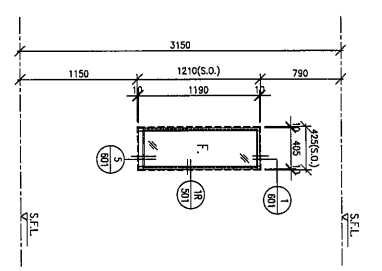
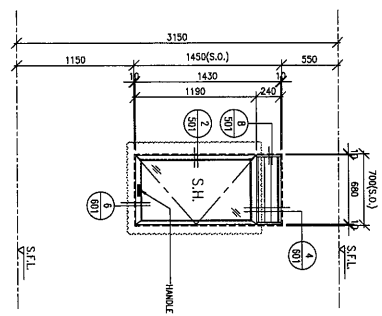

FREE AREA(%)	GLAZING AREA	OPENABLE AREA	FREE AREA(%)	GLAZING AREA	OPENABLE AREA
57%			57%		

WINDOW MARK	W10	53 nos.	WINDOW MARK	W11	26 nos.
LOCATION	T2 FLAT A NORTH(2-3)/F. 4.13.14.24/F. (UNITED) T2 FLAT D NORTH(2-3)/F. 4.13.14.24/F. (UNITED)		LOCATION	T2 FLAT D NORTH(2-3)/F. 4.13.14.24/F. (UNITED)	
GLAZING	G106	FRAME AL11	GLAZING	G106	FRAME AL11
REMARK	65mm ALUM. WINDOW SECTION		REMARK	65mm ALUM. WINDOW SECTION	

WINDOW MARK	W15	27 nos.	WINDOW MARK	W16	52 nos.
LOCATION	T2A LABY CORRIDOR(2-3)/F. 4.13.14.24/F. (UNITED)		LOCATION	T2 LABY CORRIDOR(2-3)/F. 4.13.14.24/F. (UNITED)	
GLAZING	G108	FRAME AL11	GLAZING	G108	FRAME AL11
REMARK	65mm ALUM. WINDOW SECTION		REMARK	65mm ALUM. WINDOW SECTION	

WINDOW MARK	W13	52 nos.	WINDOW MARK	W13	52 nos.
LOCATION	T2 FLAT A NORTH(2-3)/F. 4.13.14.24/F. (UNITED) T2A FLAT A NORTH(2-3)/F. 4.13.14.24/F. (UNITED)		LOCATION	T2 FLAT A NORTH(2-3)/F. 4.13.14.24/F. (UNITED)	
GLAZING	G102	FRAME AL11	GLAZING	G102	FRAME AL11
REMARK	65mm ALUM. WINDOW SECTION		REMARK	65mm ALUM. WINDOW SECTION	

B.B. REF :
F.S.D. REF :
Note :
1. All dimensions are in mm.
2. All elevations are viewed from outside.
3. All dimensions to be verified on site before fabrication.

Legend :
1. F2 - Faded Red Lead
2. S2 - Struck Red Lead
3. S - Struck
X1 - DETAIL MARK NO.
X001 - REFER SHEET NO.

NO.	DATE	REVISION
1	2012.02.02	GENERAL REVISION
2	2012.02.02	GENERAL REVISION
3		REVISION

CLIENT : 佳明集團控股有限公司
GRAND MING GROUP HOLDINGS LIMITED
MAIN CONTRACTOR : GRAND TECH CONSTRUCTION CO. LTD.

ARCHITECT : HOCK TIAN & PARTNERS LIMITED
STRUCTURAL ENGINEER : C M WONG & ASSOCIATES LTD

Project : 美特經貿有限公司
MIDI MIDORI KAWASAKI LTD.
11th Floor, 5-8, Sanyo Building, 1/F
510, Des Voeux Road, Hong Kong
Tel: (852) 4821-14 Fax: (852) 2721886
Product : RESIDENTIAL DEVELOPMENT AT
TUNG TOWN LOTT 90 SAN SHAN ROAD

TITLE : WINDOW SCHEDULE FOR PRECAST FACADE OF T2/W2A (2 OF 6)
JOB NO. : J-851
DRAWN BY : C.H.P. DATE : 20-11-2019
CHECK BY : SCALE : A1 AS 1:50
DWG. NO. : JB5-SCH-202 REV. : 8

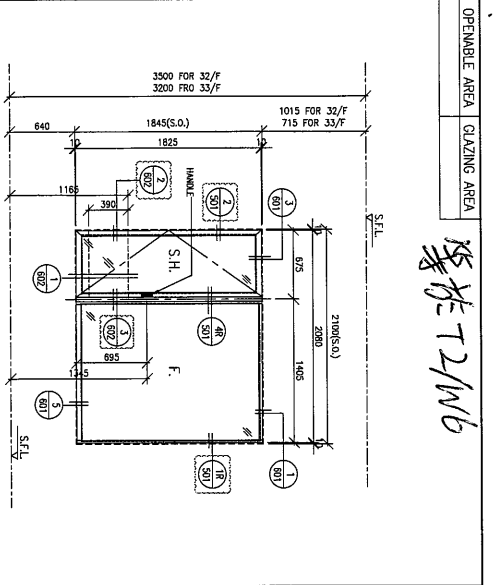

修改 T2/W6

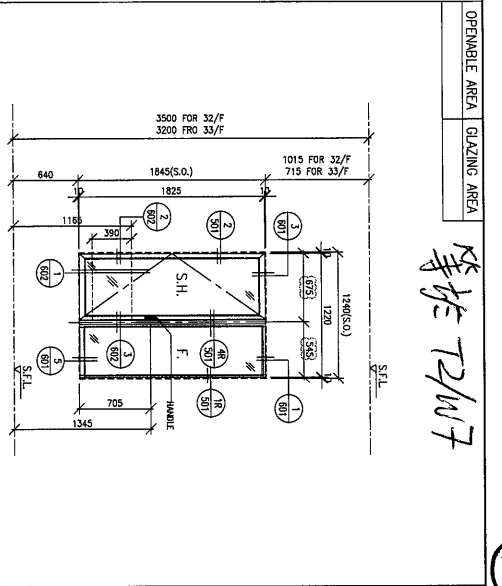

修改 T2/W7

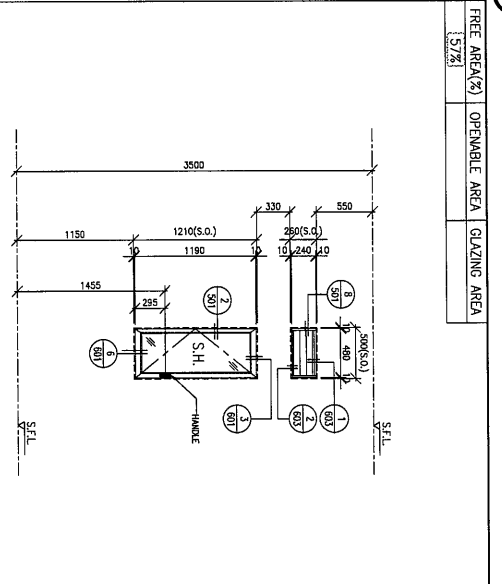

WINDOW MARK	W136		
LOCATION	T2 FLAT E M.B.H. (32/33/F)		
GLAZING	GL02	FRAME	AL11
REMARK	65mm ALUM. WINDOW SECTION		
FREE AREA(%)	OPENABLE AREA	GLAZING AREA	5.7%

修改 T2/W6/A

WINDOW MARK	W137		
LOCATION	T2 FLAT E BRZ. (32-33/F)		
GLAZING	GL02	FRAME	AL11
REMARK	65mm ALUM. WINDOW SECTION		
FREE AREA(%)	OPENABLE AREA	GLAZING AREA	5.7%

修改 T2/W11

WINDOW MARK	W138		
LOCATION	T2 FLAT B M.B.H. (33/F)		
GLAZING	GL06	FRAME	AL11
REMARK	65mm ALUM. WINDOW SECTION		
FREE AREA(%)	OPENABLE AREA	GLAZING AREA	5.7%

BA. REF :
 F.S.D. REF :
 Note :
 1. All dimensions are in mm.
 2. All dimensions are viewed from outside.
 3. All dimensions to be verified on site.
 GENERAL NOTES

Legend :
 1. F.L.— Finished Floor Level
 2. S.F.L.— Structural Floor Level
 3. B.M.— Basement Level
 X1— DETAIL MARK NO.
 X001— REFER SHEET NO.

CLIENT :
 佳明集團控股有限公司
 GRAND MING GROUP HOLDINGS LIMITED
 MAIN CONTRACTOR :
 GRAND TECH CONSTRUCTION CO. LTD.
 ARCHITECT :
 美特銘有限公司
 C M WONG & ASSOCIATES LTD
 STRUCTURAL ENGINEER :
 美特銘有限公司
 C M WONG & ASSOCIATES LTD
 PROJECT :
 RESIDENTIAL DEVELOPMENT AT
 TSING YI TOWN LOT 199 SAISHAN ROAD
 TITLE :
 WINDOW SCHEDULE
 FOR PRECAST FACADE
 OF T2/T2A (4 OF 6)
 JOB NO. : J-851
 DRAWN BY : C.H.P.
 DATE : 30-11-2019
 CHECK BY :
 SCALE : A1:150
 PNC NO. : J851-SCH-204
 REV. : B

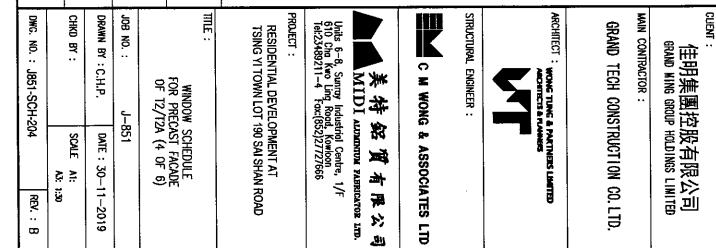

WINDOW MARK	W140		
LOCATION	T2 FLAT A M.B.H. (32/33/F)		
GLAZING	GL06	FRAME	AL11
REMARK	65mm ALUM. WINDOW SECTION		
FREE AREA(%)	OPENABLE AREA	GLAZING AREA	5.7%

13

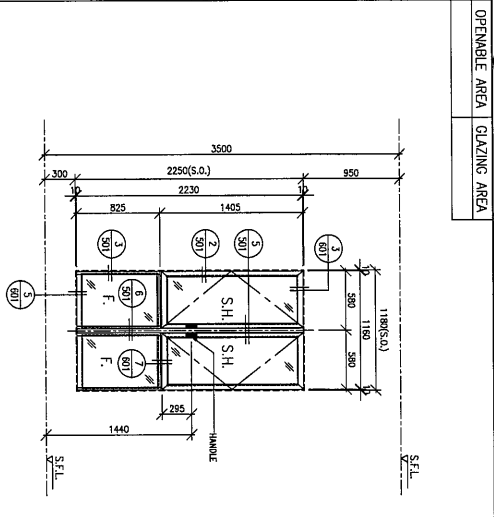
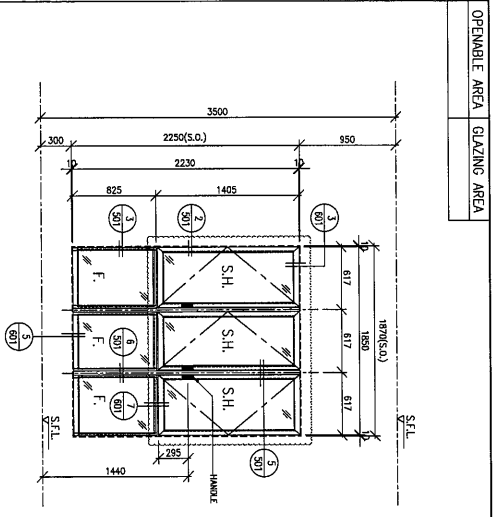

WINDOW MARK		WINDOW MARK		WINDOW MARK	
LOCATION		LOCATION		LOCATION	
GLAZING	FRAME	GLAZING	FRAME	GLAZING	FRAME
REMARK		REMARK		REMARK	

WINDOW MARK	W45 TZ 2 nos.	WINDOW MARK	W45 TZ 4 nos.
LOCATION	70A LIBERT CORRIDOR (32-33/F)	LOCATION	72 LIBERT CORRIDOR (32-33/F)
GLAZING	G108	GLAZING	G108
FRAME	FRAME	FRAME	FRAME
AL11	AL11	AL11	AL11
REMARK	65mm ALUM. WINDOW SECTION	REMARK	65mm ALUM. WINDOW SECTION

WINDOW MARK		WINDOW MARK	
LOCATION		LOCATION	
GLAZING	FRAME	GLAZING	FRAME
REMARK		REMARK	

B.O. REF :
F.S.O. REF :
Note:
1. All dimensions are in mm.
2. All elevations are viewed from outside.
3. All dimensions to be verified on site before construction.
GENERAL NOTES

- Legend :
- 1 F.F.L. — Finished Floor Level
 - 2 S.F.L. — Structural Floor Level
 - 3 — Shaded Area
 - 4 — Shaded Area
- X11 — DETAIL MARK NO.
X001 — REFER SHEET NO.

1	DATE	DESCRIPTION	BY
2	DATE	DESCRIPTION	BY
3	DATE	DESCRIPTION	BY
4	DATE	DESCRIPTION	BY

CLIENT : 佳明集團控股有限公司
GRAND MING GROUP HOLDINGS LIMITED

MAIN CONTRACTOR : GRAND TECH CONSTRUCTION CO. LTD.

ARCHITECT : 怡和洋行有限公司
HENDERSON & HENDERSON ARCHITECTS & PLANNERS

STRUCTURAL ENGINEER : C M WONG & ASSOCIATES LTD.

W45 美特鋁質有限公司
W45 美特鋁質有限公司
W45 美特鋁質有限公司
W45 美特鋁質有限公司

PROJECT : RESIDENTIAL DEVELOPMENT AT TSING YI TOWN LOT 190 SAI SHAN ROAD

TITLE : WINDOW SCHEDULE FOR PRECAST FRAME OF 12/72A (5 OF 6)

JOB NO. : J-851
DATE : 30-11-2019
SCALE : A1 : 1/30
REV : B

DATE : 30-11-2019
SCALE : A1 : 1/30
REV : B

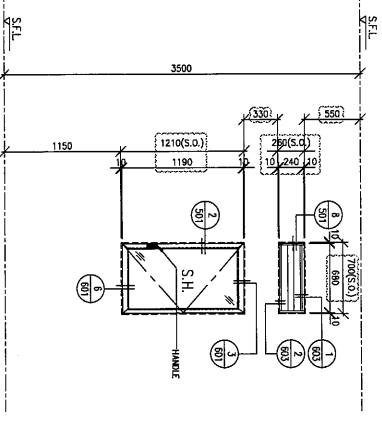

W45
TZ
2 nos.

FREE AREA(%) 1.57%	OPENABLE AREA 1330(S.O.)	GLAZING AREA 1330(S.O.)	WINDOW MARK W12 54 nos.	LOCATION T2 FLAT E MIR. (2-31/F & 33/F : 413,424/F OMITTED) T2 FLAT G MIR. (2-31/F & 33/F : 413,424/F OMITTED)	FREE AREA(%) 1.57%	OPENABLE AREA 1330(S.O.)	GLAZING AREA 1330(S.O.)	WINDOW MARK W12 54 nos.	LOCATION T2 FLAT E MIR. (2-31/F & 33/F : 413,424/F OMITTED) T2 FLAT G MIR. (2-31/F & 33/F : 413,424/F OMITTED)	OPENABLE AREA 1330(S.O.)	GLAZING AREA 1330(S.O.)	WINDOW MARK W12 54 nos.	LOCATION T2 FLAT E MIR. (2-31/F & 33/F : 413,424/F OMITTED) T2 FLAT G MIR. (2-31/F & 33/F : 413,424/F OMITTED)
-----------------------	-----------------------------	----------------------------	-------------------------------	--	-----------------------	-----------------------------	----------------------------	-------------------------------	--	-----------------------------	----------------------------	-------------------------------	--

FREE AREA(%) 1.57%	OPENABLE AREA 1190(S.O.)	GLAZING AREA 1190(S.O.)	WINDOW MARK W10 53 nos.	LOCATION T2 FLAT A MIR. (2-31/F : 413,424/F OMITTED) T2 FLAT D MIR. (2-31/F : 413,424/F OMITTED)	FREE AREA(%) 1.57%	OPENABLE AREA 1190(S.O.)	GLAZING AREA 1190(S.O.)	WINDOW MARK W10 53 nos.	LOCATION T2 FLAT A MIR. (2-31/F : 413,424/F OMITTED) T2 FLAT D MIR. (2-31/F : 413,424/F OMITTED)	OPENABLE AREA 1190(S.O.)	GLAZING AREA 1190(S.O.)	WINDOW MARK W10 53 nos.	LOCATION T2 FLAT A MIR. (2-31/F : 413,424/F OMITTED) T2 FLAT D MIR. (2-31/F : 413,424/F OMITTED)
-----------------------	-----------------------------	----------------------------	-------------------------------	--	-----------------------	-----------------------------	----------------------------	-------------------------------	--	-----------------------------	----------------------------	-------------------------------	--

FREE AREA(%) 1.57%	OPENABLE AREA 1190(S.O.)	GLAZING AREA 1190(S.O.)	WINDOW MARK W12 26 nos.	LOCATION T2 FLAT B MIR. (2-31/F : 413,424/F OMITTED)	FREE AREA(%) 1.57%	OPENABLE AREA 1190(S.O.)	GLAZING AREA 1190(S.O.)	WINDOW MARK W12 26 nos.	LOCATION T2 FLAT B MIR. (2-31/F : 413,424/F OMITTED)	OPENABLE AREA 1190(S.O.)	GLAZING AREA 1190(S.O.)	WINDOW MARK W12 26 nos.	LOCATION T2 FLAT B MIR. (2-31/F : 413,424/F OMITTED)
-----------------------	-----------------------------	----------------------------	-------------------------------	---	-----------------------	-----------------------------	----------------------------	-------------------------------	---	-----------------------------	----------------------------	-------------------------------	---

FREE AREA(%) 1.57%	OPENABLE AREA 1190(S.O.)	GLAZING AREA 1190(S.O.)	WINDOW MARK W12 2 nos.	LOCATION T2 FLAT C MIR. (2-31/F) T2 FLAT F MIR. (2-31/F)	FREE AREA(%) 1.57%	OPENABLE AREA 1190(S.O.)	GLAZING AREA 1190(S.O.)	WINDOW MARK W12 2 nos.	LOCATION T2 FLAT C MIR. (2-31/F) T2 FLAT F MIR. (2-31/F)	OPENABLE AREA 1190(S.O.)	GLAZING AREA 1190(S.O.)	WINDOW MARK W12 2 nos.	LOCATION T2 FLAT C MIR. (2-31/F) T2 FLAT F MIR. (2-31/F)
-----------------------	-----------------------------	----------------------------	------------------------------	--	-----------------------	-----------------------------	----------------------------	------------------------------	--	-----------------------------	----------------------------	------------------------------	--

FREE AREA(%) 1.57%	OPENABLE AREA 1190(S.O.)	GLAZING AREA 1190(S.O.)	WINDOW MARK W12 2 nos.	LOCATION T2 FLAT E MIR. (2-31/F) T2 FLAT G MIR. (2-31/F)	FREE AREA(%) 1.57%	OPENABLE AREA 1190(S.O.)	GLAZING AREA 1190(S.O.)	WINDOW MARK W12 2 nos.	LOCATION T2 FLAT E MIR. (2-31/F) T2 FLAT G MIR. (2-31/F)	OPENABLE AREA 1190(S.O.)	GLAZING AREA 1190(S.O.)	WINDOW MARK W12 2 nos.	LOCATION T2 FLAT E MIR. (2-31/F) T2 FLAT G MIR. (2-31/F)
-----------------------	-----------------------------	----------------------------	------------------------------	--	-----------------------	-----------------------------	----------------------------	------------------------------	--	-----------------------------	----------------------------	------------------------------	--

B.O. REF :
 F.S.O. REF :
 Note :
 1. All dimensions are in mm.
 2. All elevations are viewed from outside.
 3. All dimensions to be verified on site.
 4. All dimensions to be verified on site.
 GENERAL NOTES

Legend :
 1. F.F.L. — Finished Floor Level
 2. S.F.L. — Structural Floor Level
 3. (Symbol) — Revised Detail
 4. (Symbol) — Revised Detail
 X1 — DETAIL MARK NO.
 X001 — REFER SHEET NO.

CLIENT :
 佳明集團控股有限公司
 GRAND MING GROUP HOLDINGS LIMITED
 MAIN CONTRACTOR :
 GRAND TECH CONSTRUCTION CO. LTD.
 ARCHITECT :
 美特 建築有限公司
 C M WONG & ASSOCIATES LTD.
 STRUCTURAL ENGINEER :
 美特 建築有限公司
 MTDI Architecture Practitioners Ltd.
 PROJECT :
 RESIDENTIAL DEVELOPMENT AT
 TSING YI TOWN LOT 190 SAN SHAN ROAD
 TITLE :
 WINDOW SCHEDULE
 FOR PRECAST FACADE
 OF T2/T2A
 JOB NO. :
 J-851
 DRAWN BY : C.H.P.
 DATE : 30-11-2019
 CHECK BY :
 SCALE : As Shown
 DWS. NO. : J851-SCH-0719
 REV. : -

