



工程指示 / 要求簡箋(E.I.)

工程指示編號：EI / 9987 / 18

修改版次：-

工程編號：J - 837

工程名稱：觀塘裕民坊

工程項目：幕牆 鋁料模圖繪畫 (18 個)

收件人：Maggie

發件人：Eric Liu

日期：30/11/2018

要求提供 /  確認 事項：

- |                                    |                                     |                               |
|------------------------------------|-------------------------------------|-------------------------------|
| <input type="checkbox"/> 初步鋁料 B.M. | <input type="checkbox"/> 加工折圖，然後生產  | <input type="checkbox"/> 尺寸表  |
| <input type="checkbox"/> 正式鋁料 B.M. | <input type="checkbox"/> 技術上資料 / 指示 | <input type="checkbox"/> 報價   |
| <input type="checkbox"/> 配件 B.M.   | <input type="checkbox"/> 樣辦或貨品說明書   | <input type="checkbox"/> 分判合約 |
| <input type="checkbox"/> 其他：_____  |                                     |                               |

內容：

請留意，因 EI9660 已到 J 版，無法再登記，EI 9987 為 EI9660 修改版

1) 請繪畫模圖共 18 個，17 個為趟門模圖，1 個為修背板用

謝謝！

2) 因應港商要求，修改 X85576 及 X85577 (E2 9/85J 已開模)

請在 2018/12/05 前完成上列要求。

(若不能修改轉開新模)

附：18 頁模圖+1 頁

以上項目為：

- 原合約工程包                       原合約工程加 / 減賬                       新工程報價

原因：-

分發東莞各部門：

- ( ) 生產技術總監  連附件 ( ) 技術部  連附件  永村 ( ) 生產部  連附件 ( ) 機械設計部  連附件  
 ( ) 採購部  連附件 ( ) 生產統籌部  連附件  梅  
 ( ) 質檢部  連附件 ( ) 會計部  連附件 ( ) 報關組  連附件 ( ) 其他 楊榮輝  連附件

分發其他分判：

- ( ) 王禮秋  連附件

分發香港各部門：

- ( ) 行政部  連附件 ( ) 會計部  連附件 ( ) 統籌部  連附件 ( ) 工程部地盤科文  連附件  
 ( ) 採購部  連附件 ( ) QS 部  連附件 ( ) 維修部  連附件 ( ) 其他 \_\_\_\_\_  連附件

傳遞編號：

HK 1833 / 18

發件人簽署：

項目經理簽署：

EI 9987

類別	名稱	Page	PART	Grade	榮陽DIE No.	Die No.	0	A	B	C	D	E
企橫	雙梗企	1	M1	6063	T6	LH0089912	X85545					
企橫	生梗企	2	M2	6063	T6	LH0089913	X85546					
企橫	雙生企	3	M3	6063	T6	LH0089914	X85547					
企橫	SD中企(90)	4	M4	6063	T6	LH0089915	X85548					
企橫	轉角企	5	M5	6063	T6	LH0090004	X85549					
企橫	邊企	6	M6	6063	T6	LH0089916	X85550					
企橫	雙生托	7	M7	6063	T6	LH0089917	X85551					
企橫	雙梗橫料	8	T1	6063	T6	LH0089918	X85552					
企橫	生梗橫料	9	T2	6063	T6	LH0089919	X85553					
取消	SD窗頂橫(單玻)	10	T3	6063	T6	LH0089920	X85554					
企橫	SD窗頂橫(雙玻)	11	T3A	6063	T6	LH0089921	X85555					
窗玉	框橫料扣蓋	12	A01	6063	T5	LH0089922	X85556					
取消	生玉料(單玻)	13	A02	6063	T6	LH0089923	X85557					
窗玉	玻璃扣蓋	14	A03	6063	T6	LH0089924	X85558					
窗玉	生玉料(雙玻)	15	A04	6063	T6	LH0089925	X85559					
窗玉	單玻插線	16	A05	6063	T6	LH0089926	X85560					
窗玉	生梗企單玻	17	A06	6063	T6	LH0089927	X85561					
窗玉	生梗企雙玻	18	A07	6063	T6	LH0089928	X85562					
窗玉	生梗企單玻扣蓋	19	A08	6063	T5	LH0089929	X85563					
窗玉	生梗企雙玻扣蓋	20	A09	6063	T5	LH0089930	X85564					
套心	雙梗企套心	21	A10	6061	T6	LH0089931	X85565					
套心	生梗企套心	22	A11	6061	T6	LH0089932	X85566					
套心	雙生企套心	23	A12	6061	T6	LH0089933	X85567					
套心	轉角企套心	24	A13	6061	T6	LH0090005	X85568					
企橫	轉角外蓋	25	A14	6063	T6	LH0089934	X85569					
取消	SD平台橫料(單玻)	26	S01	6063	T6	LH0089935	X85570					
趟門	SD梗框企收邊	27	S02	6063	T5	LH0090014	X85571	1				
趟門	SD平台橫料(雙玻)	28	S03	6063	T6	LH0089936	X85572	1				
取消	SD梗框底(單玻)	29	S04	6063	T6		X85573					
趟門	SD梗框底(雙玻)	30	S05	6063	T6	LH0090103	X85574	1				
取消	SD梗企扣料(單玻)	31	S06	6063	T6		X85575					
趟門	SD梗企扣角線	32	S07	6063	T6	LH0090104	X85576	1				
趟門	SD梗企扣料(雙玻)	33	S08	6063	T6	LH0090105	X85577	1				
趟門	SD平台橫扣蓋	34	S09	6063	T5	LH0089937	X85578					
趟門	SD中柱底座	35	S10	6063	T6	LH0090106	X85579					
趟門	SD中柱勾企	36	S12	6063	T6	LH0090107	X85580	1				
趟門	SD框頂橫	37	S13	6063	T6	LH0090118	X85581	1				
趟門	SD勾企料	38	S15	6063	T6	LH0090119	X85582	1				
趟門	SD玉底橫	39	S16	6063	T6	LH0090120	X85583	1				
趟門	SD框底橫	40	S17	6063	T5	LH0090108	X85584	1				
趟門	SD玉頂橫	41	S18	6063	T6	LH0090121	X85585	1				
趟門	SD中柱扣蓋	42	S19	6063	T6	LH0090109	X85586					
FD門	FD門框底	43	F01	6063	T6		X85587					
FD門	FD門框頂	44	F02	6063	T6		X85588					
FD門	FD框企料	45	F03	6063	T5		X85589					
FD門	FD門玉料	46	F04	6063	T6		X85590					
FD門	FD門	47	F05	6063	T6		X85591					
鉛碼	固定鉛碼	48	AB01	6061	T6	LH0089938	X85592					
介子	85介子	49	AB2	6061	T6	LH0089939	X85593					
企橫	30*30*6鉛角	50	AB4	6061	T6	LH0089940	X85594					
取消	室外收口壓巴	51	AB5	6063	T5	LH0089941	X85595					
企橫	轉角企內企	52	A15	6063	T6	LH0090006	X85596					
企橫	轉角企室內蓋	53	A16	6063	T5	LH0090007	X85597					
窗玉	拉巴	54	A17	6063	T6	LH0090013	X85598					
取消	6+6玻璃用窗玉	55	A18	6063	T6	LH0090015	X85599					
介子	48介子	56	AB6	6061	T6	LH0090080	X85600					
趟門	中柱扣蓋(短)	57	S20	6063	T6	LH0090110	X85603					
趟門	趟門玉加拉手	58	S21	6063	T6	LH0090122	X85608	1				
趟門	趟門企框摩耳	59	S22	6063	T6	LH0090111	X85604	1				
取消	雙梗橫料	60	T1A	6063	T6		X85605					
趟門	玻璃拍線	61	S23	6063	T6		X85621	1				
趟門	底路軌飾線	62	S24	6063	T6		X85622	1				
趟門	底路軌(泥水用)	63	S25	6063	T6		X85623	1				
趟門	頂橫(泥水用)	64	S26	6063	T6		X85624	1				
背板	修背板位用	65	AB7	6063	T5		X85625	1				
						總數		18				

CUSTOMER	CUSTOMER APPROVAL	CUST PART NO.	S02
		SECTION NO.	X86571

LH0090014

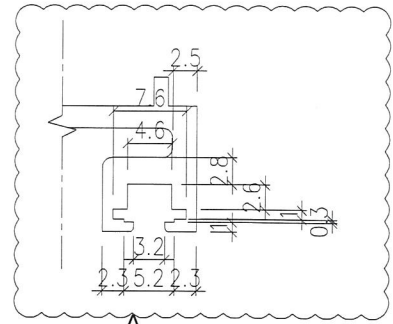

SCALE 2:1

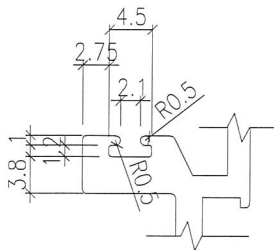
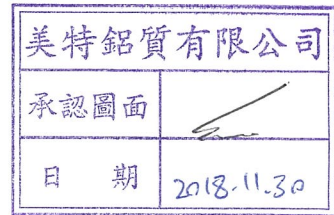
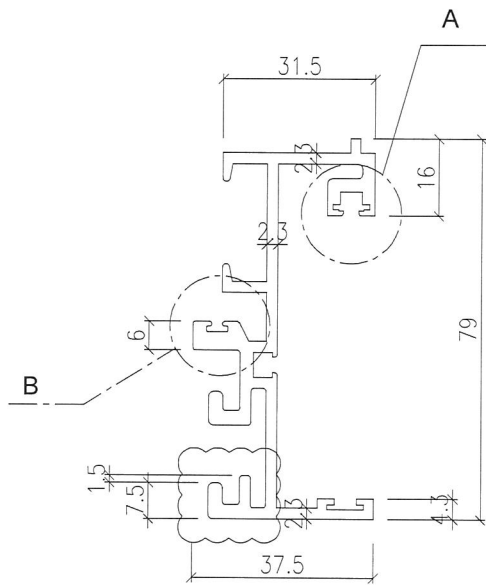

SCALE 2:1

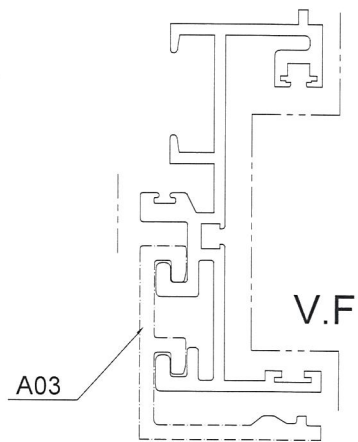

SCALE 1:1

SIGNATURE GRADEING	HIGH SIGNATURE GRADEING	C.C.DIA(MM)							
AREA (SQ MM)	587.93	UNSPECIFIED THICKNESS	-	PERIMETER (MM)	-	STANDARD		SCALE	1:1
MASS (KG/M)	-	UNSPECIFIED CORNERS	-	SURFACE AREA	-	ALLOY	6063 T6	VERSION	C
COMPANY ISSUE			DRAWN	DATE	APELLATION	-	PAGE OF		
			STANDARDIZATION	DATE					
			TO SIGN	DATE					
			AUDITING	DATE					
MARKER	MODIFY	FILE NO	SIGNATURE	DATE	APPROV				

美特鋁質有限公司  
MIDI Aluminium Fabricator Ltd.

CUSTOMER	CUSTOMER APPROVAL	CUST PART NO.	S03
		SECTION NO.	X85572

LH0089936

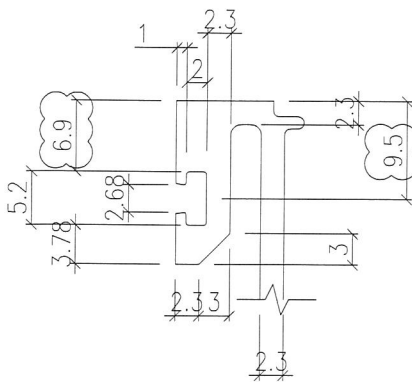
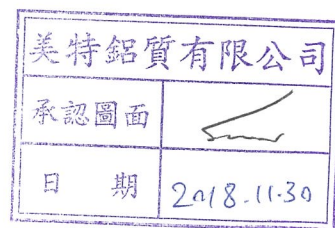
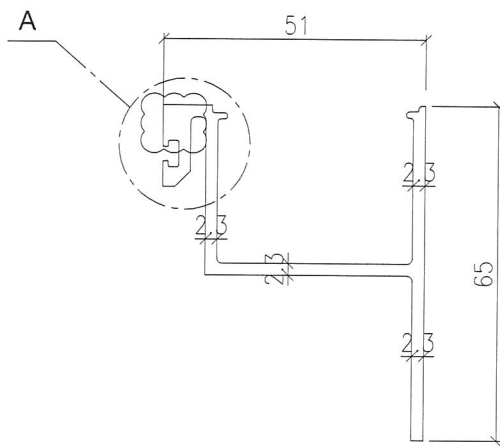

A  
SCALE 2:1

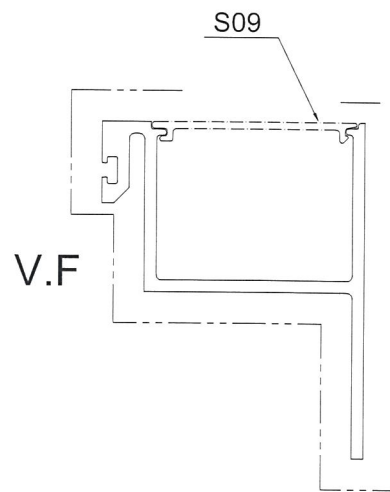

SCALE 1:1

SIGNATURE GRADEING	HIGH SIGNATURE GRADEING	C.C.DIA(MM)							
AREA (SQ MM)	388.6	UNSPECIFIED THICKNESS	-	PERIMETER (MM)	-	STANDARD		SCALE	1:1
MASS (KG/M)	-	UNSPECIFIED CORNERS	-	SURFACE AREA	-	ALLOY	6063 T6	VERSION	B
COMPANY ISSUE			DRAWA	DATE	APELLATION	-	PAGE OF		
			STANDA-RDIZATION	DATE					
			TO SIGN	DATE					
			AUDITING	DATE					
MARKER	MODIFY	FILE NO	SIGNATURE	DATE	APPROV				



CUSTOMER	CUSTOMER APPROVAL	CUST PART NO.	S05
		SECTION NO.	X85574

LH0090103

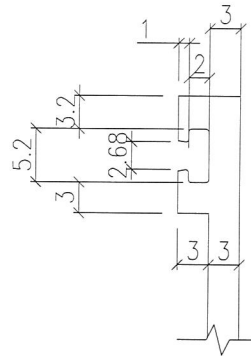

A

SCALE 2:1

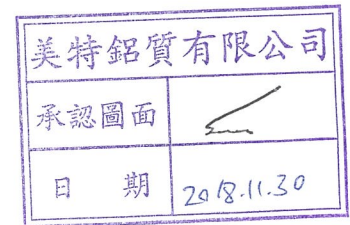
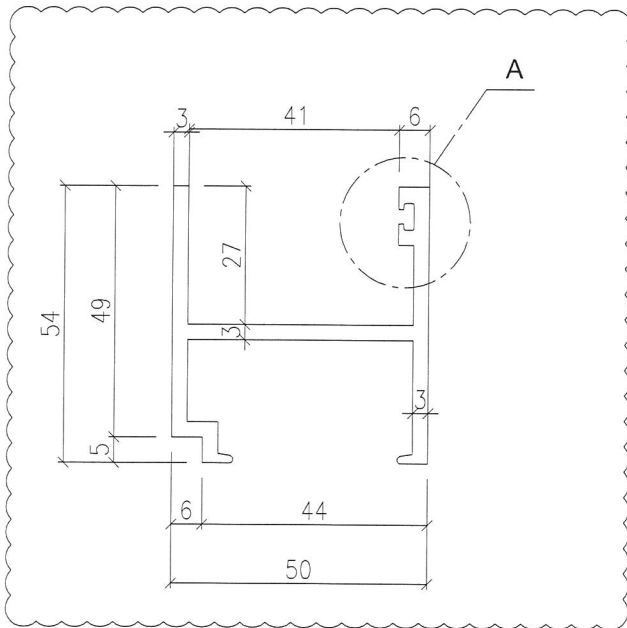

V.F

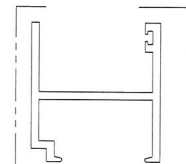

SCALE 1:2

SIGNATURE GRADEING	HIGH SIGNATURE GRADEING	C.C.DIA(MM)							
AREA (SQ MM)	504.55	UNSPECIFIED THICKNESS	-	PERIMETER (MM)	-	STANDARD		SCALE	1:1
MASS (KG/M)	-	UNSPECIFIED CORNERS	-	SURFACE AREA	-	ALLOY	6063 T6	VERSION	D
COMPANY ISSUE			DRAWA	DATE	APPELLATION	-	PAGE OF		
			STANDA-RDIZATION	DATE					
			TO SIGN	DATE					
			AUDITING	DATE					
MARKER	MODIFY	FILE NO	SIGNATURE	DATE	APPROV				

CUSTOMER	CUSTOMER APPROVAL	CUST PART NO.	S07
		SECTION NO.	X255 76

LH090104

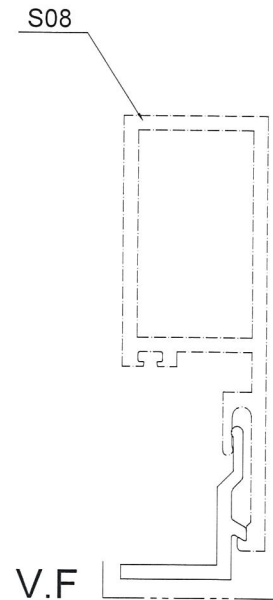
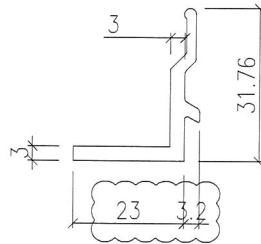
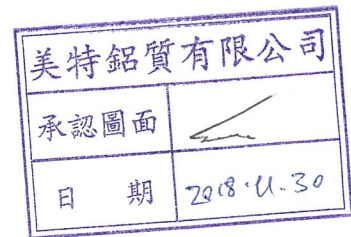

SCALE 1:1

SIGNATURE GRADEING	HIGH SIGNATURE GRADEING	C.C.DIA(MM)							
AREA (SQ MM)	156.27	UNSPECIFIED THICKNESS	-	PERIMETER (MM)	-	STANDARD		SCALE	1:1
MASS (KG/M)	-	UNSPECIFIED CORNERS	-	SURFACE AREA	-	ALLOY	6063 T6	VERSION	B
COMPANY ISSUE			DRAWA	DATE	APELATION		-	PAGE OF	
			STANDA-	DATE					
			RDIZATION	DATE					
			TO SIGN	DATE					
			AUDITING	DATE					
MARKER	MODIFY	FILE NO	SIGNATURE	DATE	APPROV				

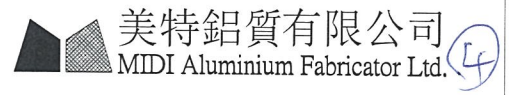

CUSTOMER	CUSTOMER APPROVAL	CUST PART NO.	S08
		SECTION NO.	X85577

LM0090105

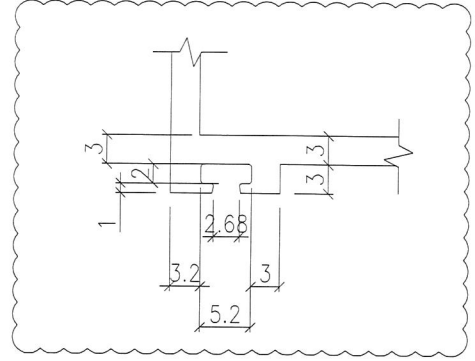
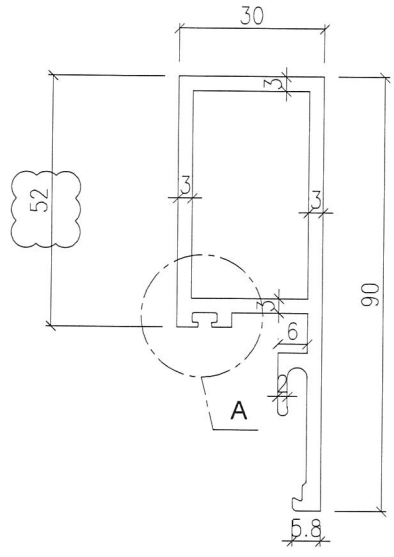

A  
SCALE 2:1

美特鋁質有限公司	
承認圖面	
日期	2018.11.30

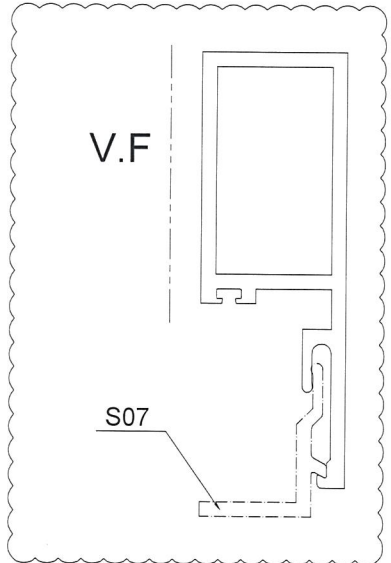

V.F  
S07  
SCALE 1:1

SIGNATURE GRADEING	HIGH SIGNATURE GRADEING	C.C.DIA(MM)							
AREA (SQ MM)	630.71	UNSPECIFIED THICKNESS	-	PERIMETER (MM)	-	STANDARD		SCALE	1:1
MASS (KG/M)	-	UNSPECIFIED CORNERS	-	SURFACE AREA	-	ALLOY	6063 T6	VERSION	B
COMPANY ISSUE			DRAWN	DATE	APPELLATION	-	PAGE OF		
			STANDARDIZATION	DATE					
			TO SIGN	DATE					
			AUDITING	DATE					
MARKER	MODIFY	FILE NO	SIGNATURE	DATE	APPROV				

美特鋁質有限公司  
MIDI Aluminium Fabricator Ltd.

LH0090107

CUSTOMER	CUSTOMER APPROVAL	CUST PART NO.	S12
		SECTION NO.	X8558e

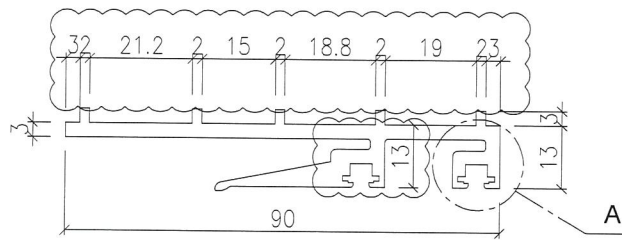
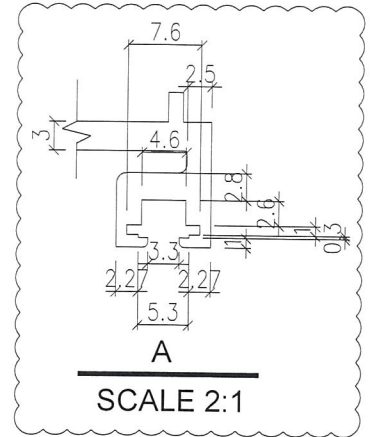

美特鋁質有限公司	
承認圖面	
日期	2018-11-30

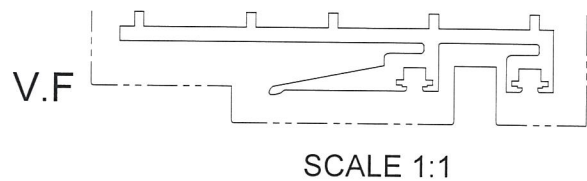

SIGNATURE GRADEING	HIGH SIGNATURE GRADEING	C.C.DIA(MM)							
AREA (SQ MM)	500.7	UNSPECIFIED THICKNESS	-	PERIMETER (MM)	-	STANDARD		SCALE	1:1
MASS (KG/M)	-	UNSPECIFIED CORNERS	-	SURFACE AREA	-	ALLOY	6063 T6	VERSION	C
COMPANY ISSUE			DRAWN	DATE	APELLATION	-	PAGE OF		
			STANDARDIZATION	DATE					
			TO SIGN	DATE					
			AUDITING	DATE					
MARKER	MODIFY	FILE NO	SIGNATURE	DATE	APPROV				

美特鋁質有限公司  
MIDI Aluminium Fabricator Ltd.

6

CUSTOMER	CUSTOMER APPROVAL	CUST PART NO.	S13
		SECTION NO.	X85581

LH0090118

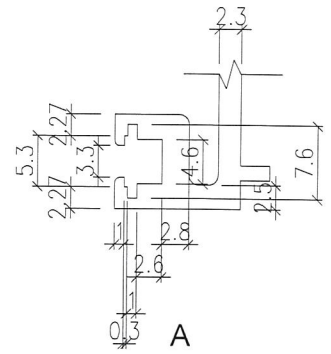
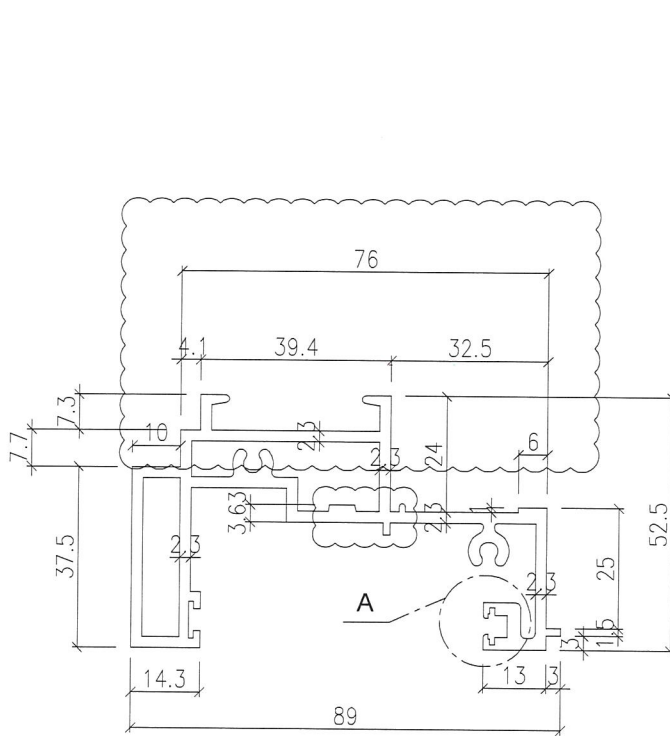

SCALE 2:1

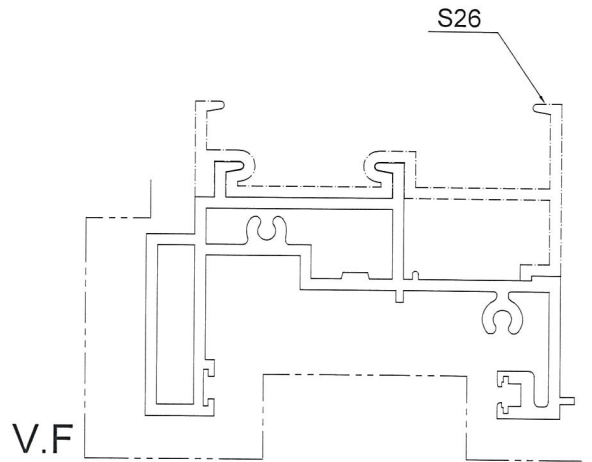
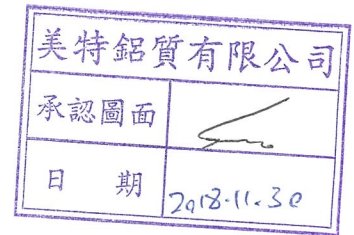

SCALE 1:1

SIGNATURE GRADEING	HIGH SIGNATURE GRADEING	C.C.DIA(MM)							
AREA (SQ MM)	806.8	UNSPECIFIED THICKNESS	-	PERIMETER (MM)	-	STANDARD		SCALE	1:1
MASS (KG/M)	-	UNSPECIFIED CORNERS	-	SURFACE AREA	-	ALLOY	6063 T6	VERSION	D
COMPANY ISSUE			DRAWA	DATE	APPELLATION	-	PAGE OF		
			STANDA-	DATE					
			RDIZATION	DATE					
			TO SIGN	DATE					
			AUDITING	DATE					
MARKER	MODIFY	FILE NO	SIGNATURE	DATE	APPROV				

美特鋁質有限公司  
MIDI Aluminium Fabricator Ltd.

7

CUSTOMER	CUSTOMER APPROVAL	CUST PART NO.	S15
		SECTION NO.	X85582

L40090119

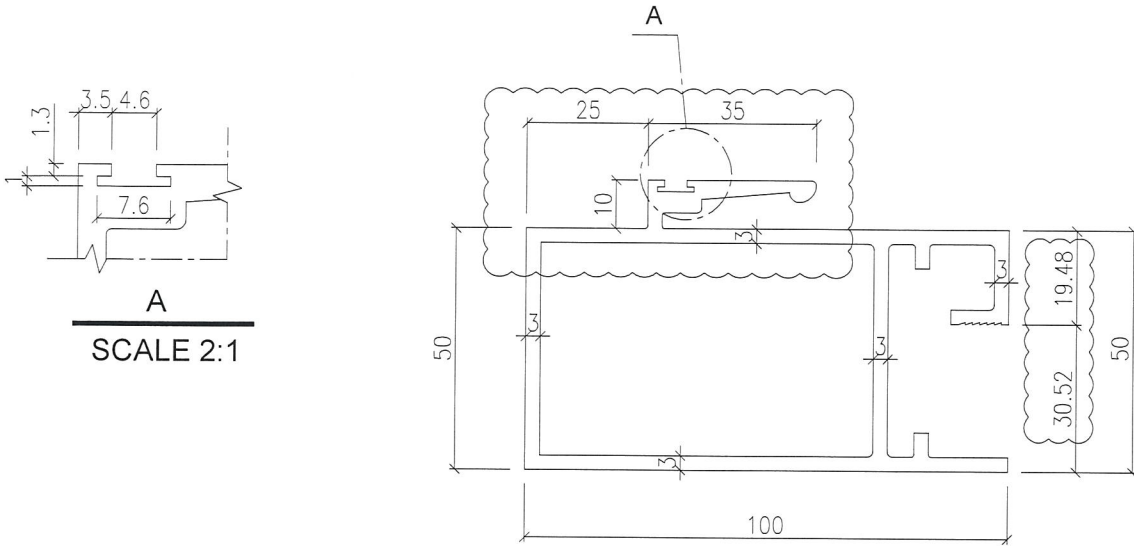

A  
SCALE 2:1

美特鋁質有限公司	
承認圖面	
日期	2018-11-30

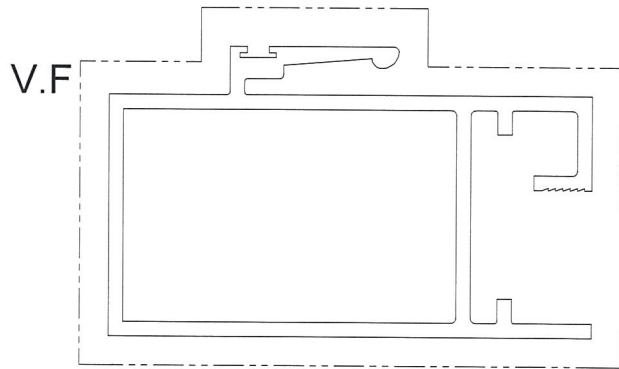
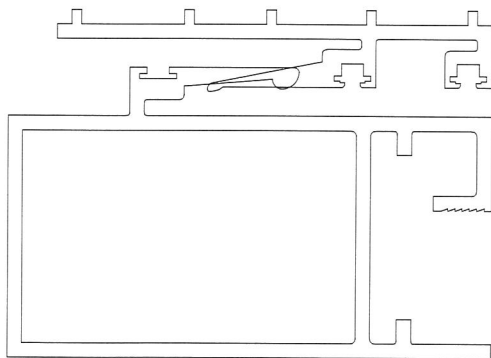

SCALE 1:1

SIGNATURE GRADEING	HIGH SIGNATURE GRADEING	C.C.DIA(MM)							
AREA (SQ MM)	1118.23	UNSPECIFIED THICKNESS	-	PERIMETER (MM)	-	STANDARD		SCALE	1:1
MASS (KG/M)	-	UNSPECIFIED CORNERS	-	SURFACE AREA	-	ALLOY	6063 T6	VERSION	C
COMPANY ISSUE			DRAWA	DATE	APELATION		-	PAGE OF	
			STANDA- RDIZATION	DATE					
			TO SIGN	DATE					
			AUDITING	DATE					
MARKER	MODIFY	FILE NO	SIGNATURE	DATE	APPROV	DATE			

美特鋁質有限公司  
MIDI Aluminium Fabricator Ltd.



LH009908

CUSTOMER	CUSTOMER APPROVAL	CUST PART NO.	S17
		SECTION NO.	X85584

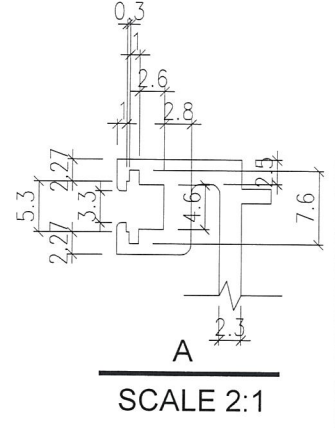
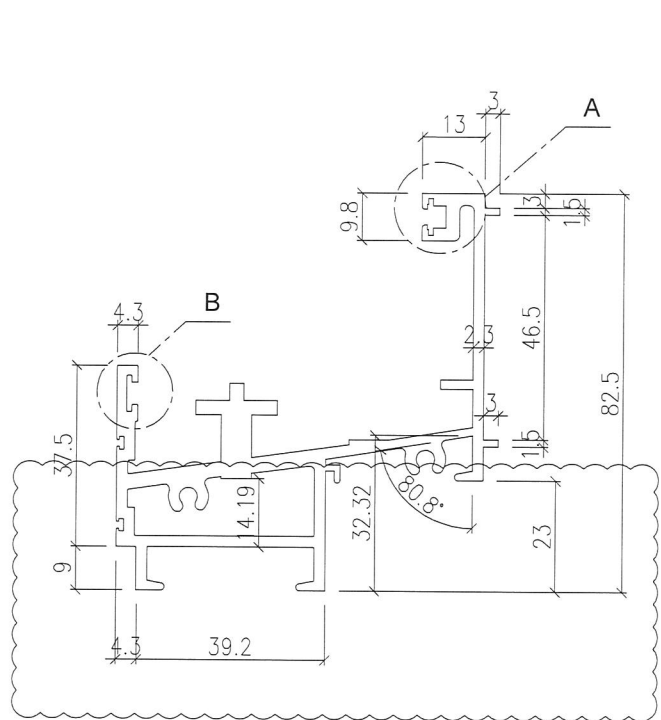

美特鋁質有限公司  
承認圖面  
日期 2018.11.30

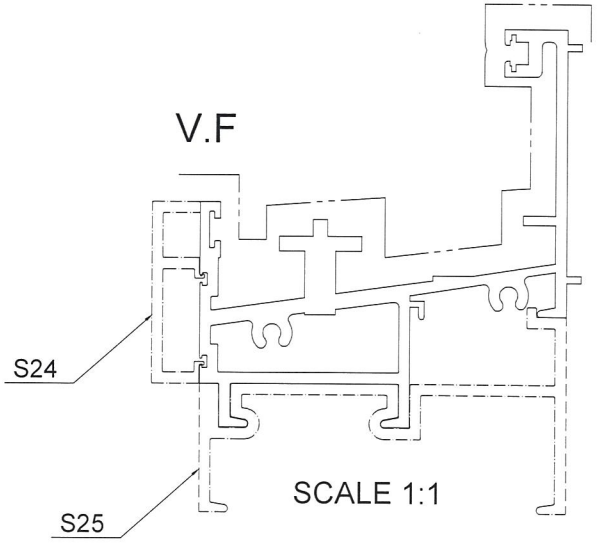
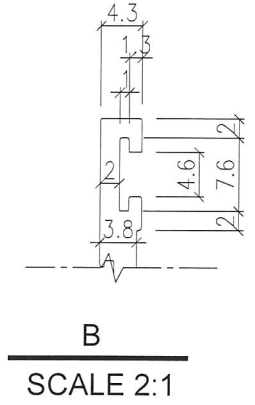

SIGNATURE GRADEING	HIGH SIGNATURE GRADEING	C.C.DIA(MM)							
AREA (SQ MM)	913.95	UNSPECIFIED THICKNESS	-	PERIMETER (MM)	-	STANDARD		SCALE	1:1
MASS (KG/M)	-	UNSPECIFIED CORNERS	-	SURFACE AREA	-	ALLOY	6063 T6	VERSION	E
COMPANY ISSUE			DRAWA	DATE	APPELLATION	-	PAGE OF		
			STANDAR-DIZATION	DATE					
			TO SIGN	DATE					
			AUDITING	DATE					
MARKER	MODIFY	FILE NO	SIGNATURE	DATE	APPROV	DATE			

美特鋁質有限公司  
MIDI Aluminium Fabricator Ltd.

10

CUSTOMER	CUSTOMER APPROVAL	CUST PART NO.	S18
		SECTION NO.	X85585

LH0090121

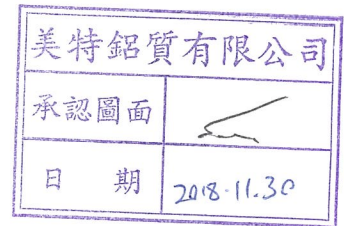
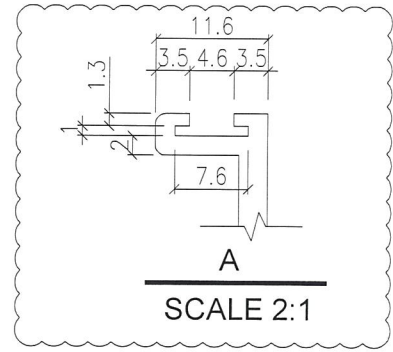
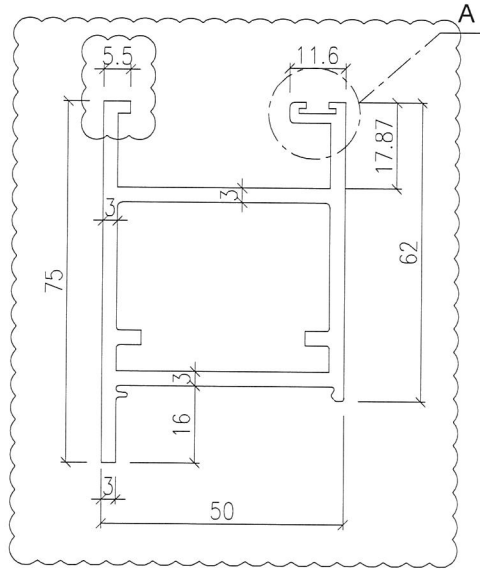

V.F

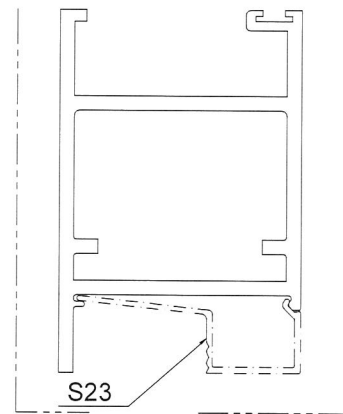

SCALE 1:1

SIGNATURE GRADEING	HIGH SIGNATURE GRADEING	C.C.DIA(MM)							
AREA (SQ MM)	742.91	UNSPECIFIED THICKNESS	-	PERIMETER (MM)	-	STANDARD		SCALE	1:1
MASS (KG/M)	-	UNSPECIFIED CORNERS	-	SURFACE AREA	-	ALLOY	6063 T6	VERSION	D
COMPANY ISSUE				DRAWA	DATE	APPELLATION	-	PAGE OF	
			STANDA-	DATE		<p>美特鋁質有限公司 MIDI Aluminium Fabricator Ltd.</p>			
			RDIZATION						
			TO SIGN	DATE					
			AUDITING	DATE					
MARKER	MODIFY	FILE NO	SIGNATURE	DATE	APPROV	DATE			

(11)

CUSTOMER	CUSTOMER APPROVAL	CUST PART NO.	S21
		SECTION NO.	X85608

LH0099122

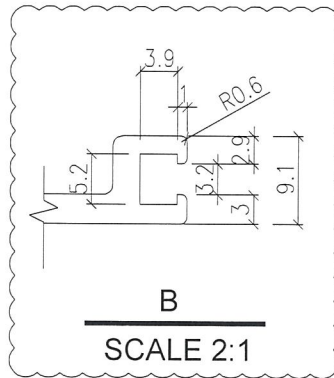
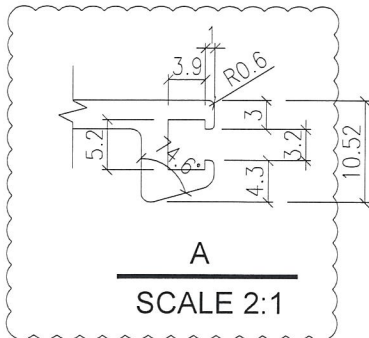
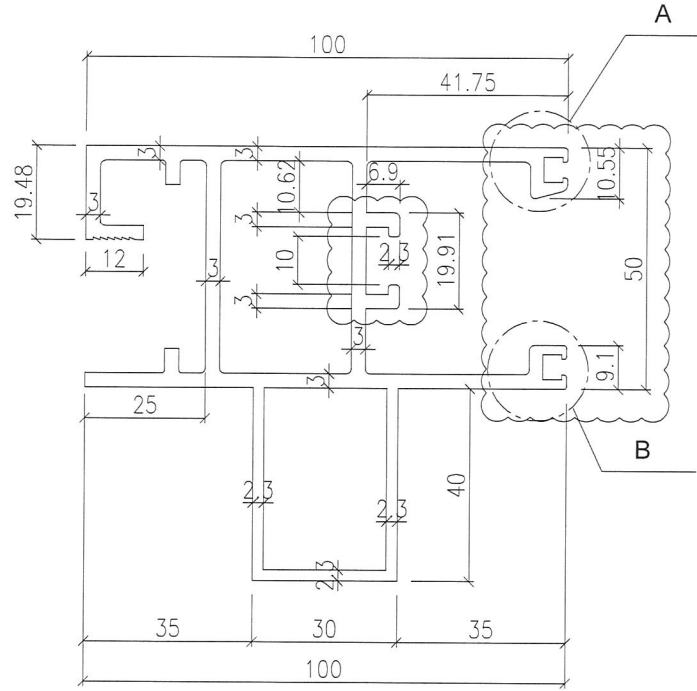

美特鋁質有限公司	
承認圖面	
日期	2018.11.30

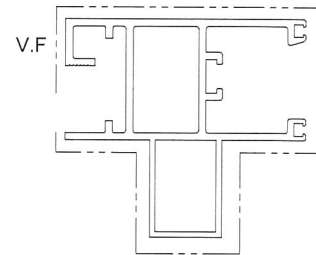

SCALE 1:2

SIGNATURE GRADEING	HIGH SIGNATURE GRADEING	C.C.DIA(MM)							
AREA (SQ MM)	1314.21	UNSPECIFIED THICKNESS	-	PERIMETER (MM)	-	STANDARD		SCALE	1:1
MASS (KG/M)	-	UNSPECIFIED CORNERS	-	SURFACE AREA	-	ALLOY	6063 T6	VERSION	C
COMPANY ISSUE				DRAWN	DATE	APPELLATION	-	PAGE OF	
				STANDARDIZATION	DATE				
				TO SIGN	DATE				
				AUDITING	DATE				
MARKER	MODIFY	FILE NO	SIGNATURE	DATE	APPROV	DATE			

美特鋁質有限公司  
MIDI Aluminium Fabricator Ltd.

CUSTOMER	CUSTOMER APPROVAL	CUST PART NO.	S22
		SECTION NO.	X854604

LH 0090111

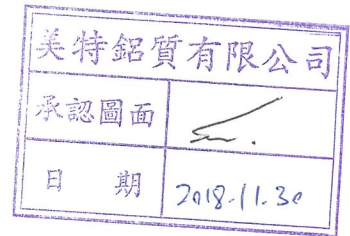
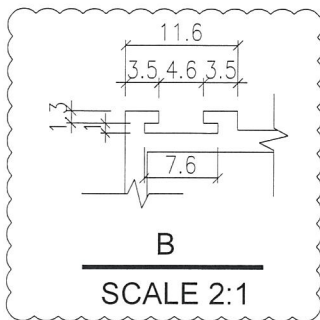
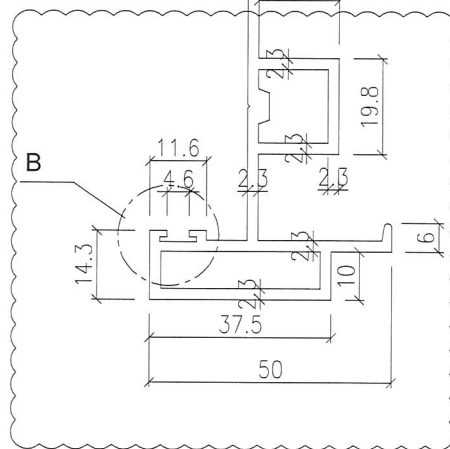
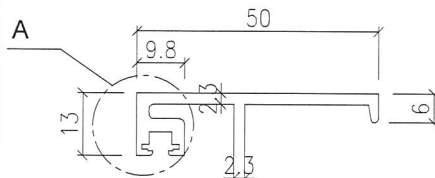
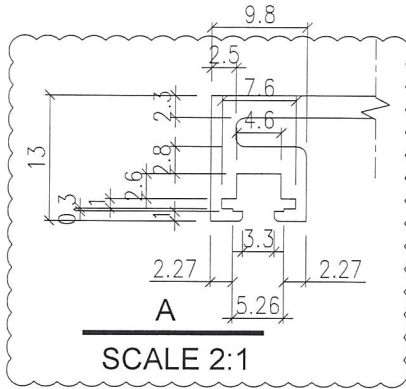

SCALE 1:2

SIGNATURE GRADEING	HIGH SIGNATURE GRADEING	C.C.DIA(MM)							
AREA (SQ MM)	722.18	UNSPECIFIED THICKNESS	-	PERIMETER (MM)	-	STANDARD		SCALE	1:1
MASS (KG/M)	-	UNSPECIFIED CORNERS	-	SURFACE AREA	-	ALLOY	6063 T6	VERSION	B
COMPANY ISSUE			DRAWN	DATE	APELLATION	-	PAGE OF		
			STANDARDIZATION	DATE			美特鋁質有限公司 MIDI Aluminium Fabricator Ltd.		
			TO SIGN	DATE					
			AUDITING	DATE					
MARKER	MODIFY	FILE NO	SIGNATURE	DATE	APPROV	DATE			

(13)

CUSTOMER	CUSTOMER APPROVAL	CUST PART NO.	S23
		SECTION NO.	X85621

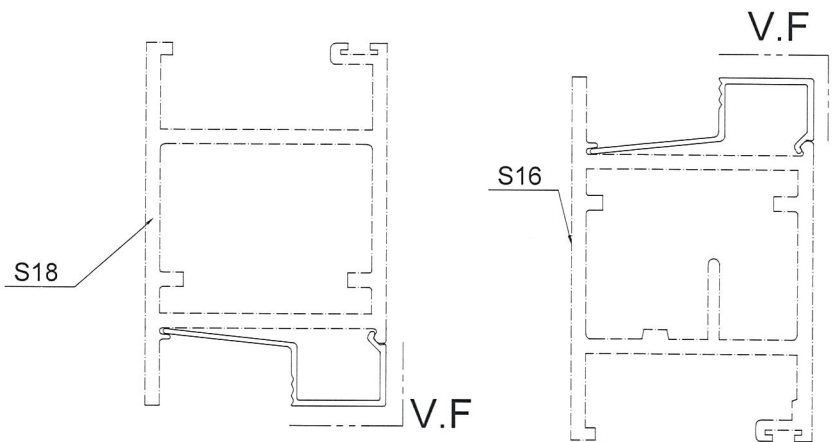
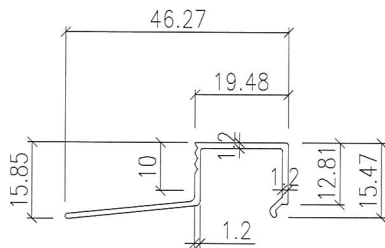

SCALE 1:1

SCALE 1:1

SIGNATURE GRADEING	HIGH SIGNATURE GRADEING	C.C.DIA(MM)							
AREA (SQ MM)	81.27	UNSPECIFIED THICKNESS	-	PERIMETER (MM)	-	STANDARD		SCALE	1:1
MASS (KG/M)	-	UNSPECIFIED CORNERS	-	SURFACE AREA	-	ALLOY	6063 T6	VERSION	
COMPANY ISSUE			DRAWA	DATE	APELLATION	-	PAGE OF		
			STANDA- RDIZATION	DATE					
			TO SIGN	DATE					
			AUDITING	DATE					
MARKER	MODIFY	FILE NO	SIGNATURE	DATE	APPROV				

美特鋁質有限公司  
MIDI Aluminium Fabricator Ltd.

16

CUSTOMER	CUSTOMER APPROVAL	CUST PART NO.	S24
		SECTION NO.	X85622

美特鋁質有限公司	
承認圖面	
日期	2018.11.30

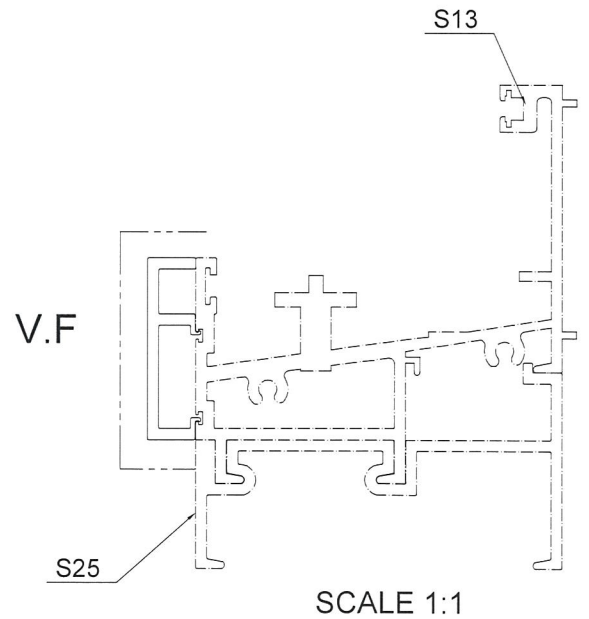
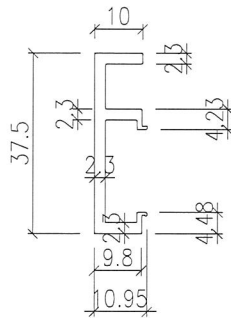

SIGNATURE GRADEING	HIGH SIGNATURE GRADEING	C.C.DIA(MM)							
AREA (SQ MM)	153.09	UNSPECIFIED THICKNESS	-	PERIMETER (MM)	-	STANDARD		SCALE	1:1
MASS (KG/M)	-	UNSPECIFIED CORNERS	-	SURFACE AREA	-	ALLOY	6063 T6	VERSION	
COMPANY ISSUE			DRAWA	DATE	APELLATION		-	PAGE OF	
			STANDA-RDIZATION	DATE	 <b>美特鋁質有限公司</b> MIDI Aluminium Fabricator Ltd.				
			TO SIGN	DATE					
			AUDITING	DATE					
MARKER	MODIFY	FILE NO	SIGNATURE	DATE					

15

CUSTOMER		CUSTOMER APPROVAL		CUST PART NO.	S25
				SECTION NO.	X85623

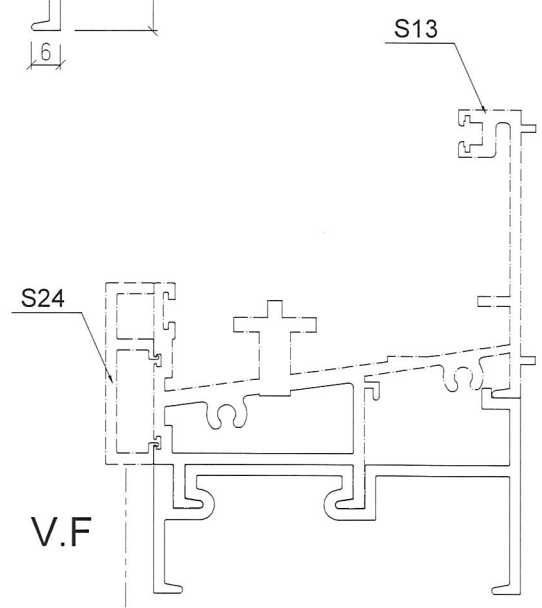
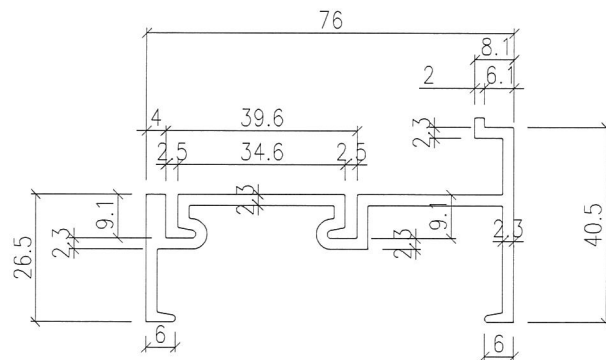

SCALE 1:1

SIGNATURE GRADEING	HIGH SIGNATURE GRADEING	C.C.DIA(MM)							
AREA (SQ MM)	449.54	UNSPECIFIED THICKNESS	-	PERIMETER (MM)	-	STANDARD		SCALE	1:1
MASS (KG/M)	-	UNSPECIFIED CORNERS	-	SURFACE AREA	-	ALLOY	6063 T6	VERSION	
COMPANY ISSUE			DRAWA	DATE	APELLATION	-	PAGE OF		
			STANDA-RDIZATION	DATE					
			TO SIGN	DATE					
			AUDITING	DATE					
MARKER	MODIFY	FILE NO	SIGNATURE	DATE	APPROV				

美特鋁質有限公司  
MIDI Aluminium Fabricator Ltd.

16

CUSTOMER		CUSTOMER APPROVAL		CUST PART NO.	S26
				SECTION NO.	X85624

美特鋁質有限公司	
承認圖面	
日期	2018-11-30

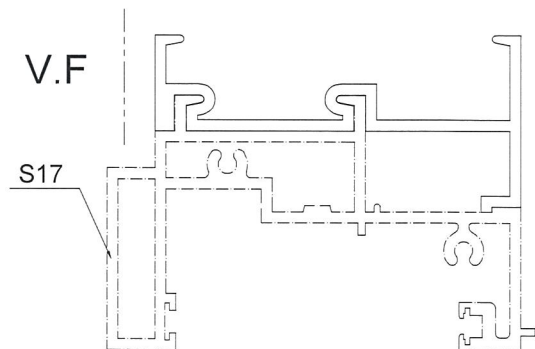
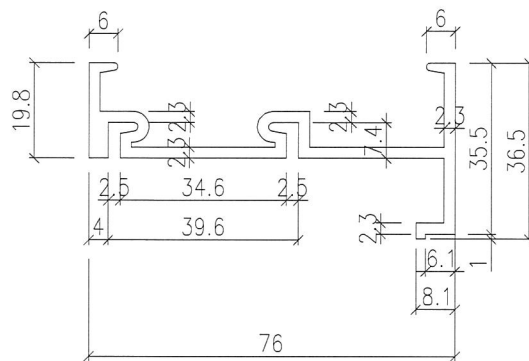

SCALE 1:1

SIGNATURE GRADEING	HIGH SIGNATURE GRADEING	C.C.DIA(MM)							
AREA (SQ MM)	408.4	UNSPECIFIED THICKNESS	-	PERIMETER (MM)	-	STANDARD		SCALE	1:1
MASS (KG/M)	-	UNSPECIFIED CORNERS	-	SURFACE AREA	-	ALLOY	6063 T6	VERSION	
COMPANY ISSUE			DRAWN	DATE	APELLATION	-	PAGE OF		
			STANDARDIZATION	DATE					
			TO SIGN	DATE					
			AUDITING	DATE					
MARKER	MODIFY	FILE NO	SIGNATURE	DATE	APPROV	DATE			

 美特鋁質有限公司  
MIDI Aluminium Fabricator Ltd.

(17)

CUSTOMER		CUSTOMER APPROVAL		CUST PART NO.	AB7
				SECTION NO.	X85625

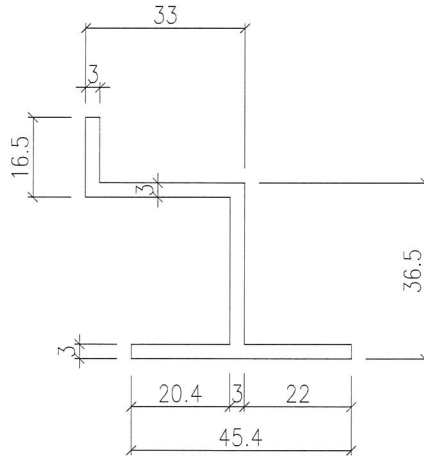

美特鋁質有限公司	
承認圖面	
日期	2018.11.30

SIGNATURE GRADEING	HIGH SIGNATURE GRADEING	C.C.DIA(MM)							
AREA (SQ MM)	367.19	UNSPECIFIED THICKNESS	-	PERIMETER (MM)	-	STANDARD		SCALE	1:1
MASS (KG/M)	-	UNSPECIFIED CORNERS	-	SURFACE AREA	-	ALLOY	6063 T5	VERSION	
COMPANY ISSUE			DRAWN	DATE	APPELLATION		-	PAGE OF	
			STANDARDIZATION	DATE	 美特鋁質有限公司 MIDI Aluminium Fabricator Ltd.				
			TO SIGN	DATE					
			AUDITING	DATE					
MARKER	MODIFY	FILE NO	SIGNATURE	DATE					

20