



工程指示 / 要求簡箋(E.I.)

工程指示編號：EI/994 / 18

修改版次：-

工程編號：J - 837

工程名稱：觀塘裕民坊

工程項目：幕牆用 鋁碼及鋁介子(鋁碼 鐵碼用)

收件人：生統 / 永林

發件人：Eric Liu

日期：15/11/2018

要求提供 / 確認 事項：

- | | | |
|------------------------------------|-------------------------------------|-------------------------------|
| <input type="checkbox"/> 初步鋁料 B.M. | <input type="checkbox"/> 加工拆圖，然後生產 | <input type="checkbox"/> 尺寸表 |
| <input type="checkbox"/> 正式鋁料 B.M. | <input type="checkbox"/> 技術上資料 / 指示 | <input type="checkbox"/> 報價 |
| <input type="checkbox"/> 配件 B.M. | <input type="checkbox"/> 樣辦或貨品說明書 | <input type="checkbox"/> 分判合約 |
| <input type="checkbox"/> 其他：_____ | | |

內容：

請按加工圖生產幕牆用鋁碼及介子

請留意: 1) 絲杆位置雙介子取消，改用平介(加工圖數量已減)，

2) 40x40mm 鐵巴取消，改六角頭反轉修，用 40x4mm 鋁巴，永林請補回數量

3) 包裝請 按座、按層、按單位

4) 出貨分 5 批，每次 8 層，出貨期:

第一批:11 月尾、第二批: 12 月尾、第三批: 1 月尾、第四批: 3 月頭、第五批: 4 月尾(餘數)

謝謝！ (11 月 26 先出樣板層用數量)

請在 2018/ 12 / 1 前完成上列要求。

附：1 頁，3 頁圖登，18 頁加工圖，50 頁位置圖

以上項目為:

- 原合約工程包 原合約工程加 / 減賬 新工程報價

原因：-

分發東莞各部門：

- () 生產技術總監 連附件 (/) 技術部 連附件 *柯* () 生產部 連附件 () 機械設計部 連附件
 () 採購部 連附件 (/) 生產統籌部 連附件 *柯*
 () 質檢部 連附件 () 會計部 連附件 () 報關組 連附件 () 其他 楊榮輝 連附件

分發香港各部門：

- () 行政部 連附件 () 會計部 連附件 () 統籌部 連附件 (/) 工程部地盤科文 連附件 *柯*
 () 採購部 連附件 () QS 部 連附件 () 維修部 連附件 () 其他 _____ 連附件

傳遞編號：

發件人簽署：
Eric Liu

HK *1753* / 18

項目經理簽署：
[Signature]

改用40x4鋁角, 六角型反轉修

穩固
參考用

100 x 138 x 10 mm THK. G.M.S. PLATE FORMED BRACKET (L=200mm)
10 mm THK. G.M.S. GUSSET PLATE
EDGE OF R.C. STRUCTURE

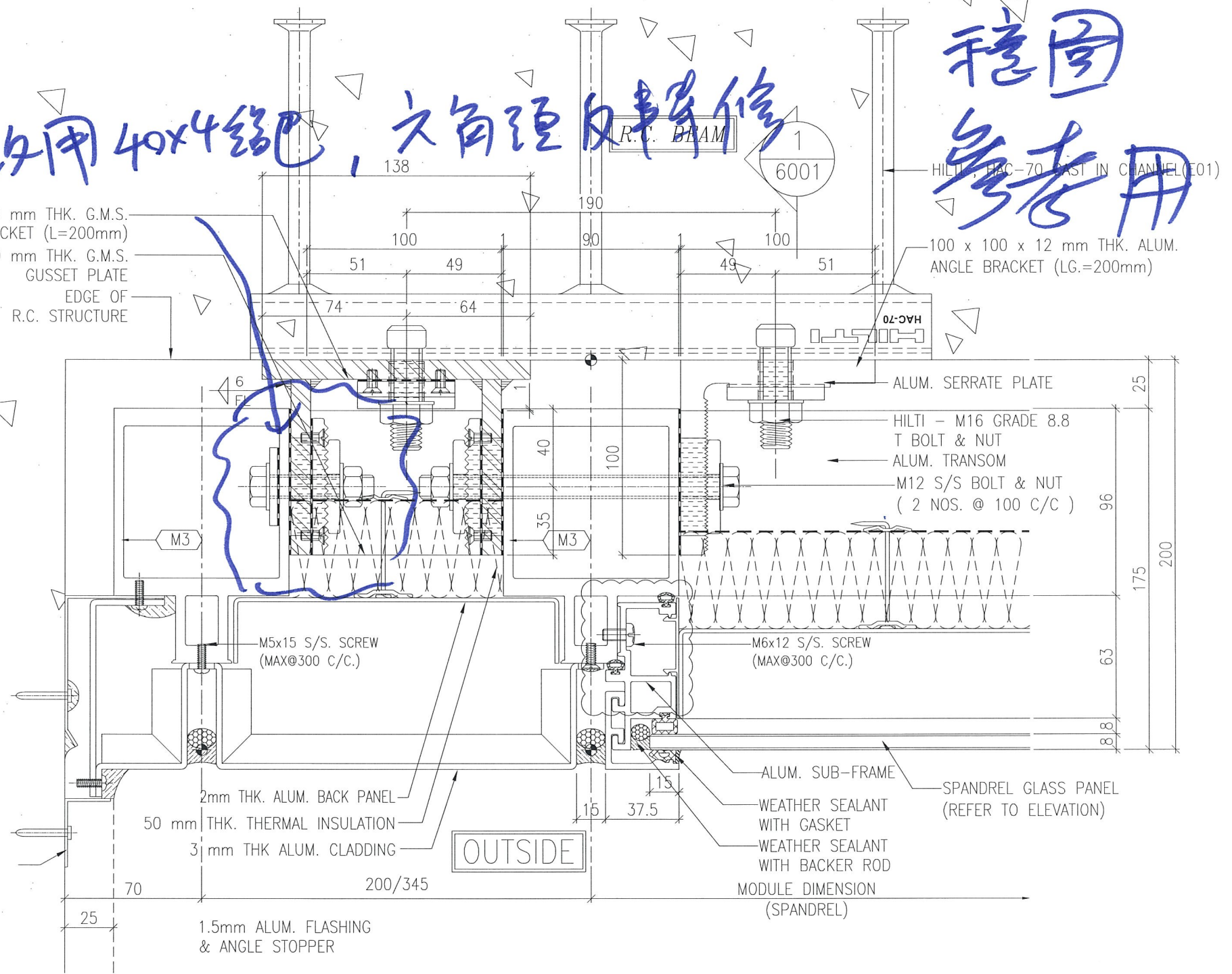

- ① 40鋁巴 + 反轉介子
- ② 絲扣位介子轉介
- ③

圖則登記表

DRAWING REGISTER

圖則登記表		DRAWING REGISTER									
工程名稱 Project Title: 觀塘裕民坊(8F-26F,29F-49F)		接收日期 Receiving Date (適用於客戶圖則)									
幕牆鋁碼及鐵掛碼安裝示意圖		年									
工程編號 Project No: J-837		月									
分發予 Distributed To		日									
		年	18								
		月	11								
		日	6								
圖則編號 Drg. No.	圖則名稱 Drawing Title	修訂編號 Revision No.									
837-BD01	固定鋁碼加工圖	1	-								
837-PJ03	85鋁巴	2	-								
837-PJ03-1	85鋁巴	3	-								
837-PJ03-2	48鋁介子	4	-								
837-PJ03-4	40鋁介子	5	-								
837-DL01	鐵碼組裝鋁件安裝示意圖	6	-								
837-DL01(1)	鐵碼組裝鋁件安裝示意圖(數據表)	7	-								
837-DL02	鐵碼組裝鋁件安裝示意圖	8	-								
837-DL02(1)	鐵碼組裝鋁件安裝示意圖(數據表)	9	-								
837-DL03	大鐵碼組裝鋁件安裝示意圖	10	-								
837-DL03(1)	大鐵碼組裝鋁件安裝示意圖(數據表)	11	-								
837-DL04	大鐵碼組裝鋁件安裝示意圖	12	-								
837-DL04(1)	大鐵碼組裝鋁件安裝示意圖(數據表)	13	-								
837-DL05	雙主企鐵碼組裝鋁件安裝示意圖	14	-								
837-DL06	雙主企鐵碼組裝鋁件安裝示意圖	15	-								
837-DL07	轉角鐵碼組裝鋁件安裝示意圖	16	-								
837-AG01	固定鋁碼安裝示意圖	17	-								
837-AG01(1)	固定鋁碼安裝示意圖(數據表)	18	-								
J837-CW-2101	位置圖	19	-								
J837-CW-2102	位置圖	20	-								
J837-CW-2103	位置圖	21	-								

圖則登記表
DRAWING REGISTER

接收日期 Receiving Date (適用於客戶圖則)

工程名稱 Project Title: **觀塘裕民坊(8F-26F,29F-49F)**
幕牆鋁碼及鐵掛碼安裝示意圖

工程編號 Project No: **J-837**

年																			
月																			
日																			

分發予 Distributed To

年	18																		
月	11																		
日	6																		

圖則編號 Drg. No.	圖則名稱 Drawing Title
J837-CW-2104	位置圖
J837-CW-2105	位置圖
J837-CW-2106	位置圖
J837-CW-2107	位置圖
J837-CW-2108	位置圖
J837-CW-2109	位置圖
J837-CW-2110	位置圖
J837-CW-2111	位置圖
J837-CW-2112	位置圖
J837-CW-2113	位置圖
J837-CW-2201	位置圖
J837-CW-2202	位置圖
J837-CW-2203	位置圖
J837-CW-2204	位置圖
J837-CW-2205	位置圖
J837-CW-2206	位置圖
J837-CW-2207	位置圖
J837-CW-2208	位置圖
J837-CW-2209	位置圖
J837-CW-2210	位置圖
J837-CW-2211	位置圖
J837-CW-2212	位置圖
J837-CW-2213	位置圖
J837-CW-2301	位置圖

修訂編號 Revision No.																			
22	-																		
23	-																		
24	-																		
25	-																		
26	-																		
27	-																		
28	-																		
29	-																		
30	-																		
31	-																		
32	-																		
33	-																		
34	-																		
35	-																		
36	-																		
37	-																		
38	-																		
39	-																		
40	-																		
41	-																		
42	-																		
43	-																		
44	-																		
45	-																		

圖則登記表
DRAWING REGISTER

接收日期 Receiving Date (適用於客戶圖則)														
工程名稱 Project Title: 觀塘裕民坊(8F-26F,29F-49F)	年													
幕牆鉛碼及鐵掛碼安裝示意圖	月													
工程編號 Project No: J-837	日													
分發予 Distributed To														
		年	18											
		月	11											
		日	6											
圖則編號 Drg. No.	圖則名稱 Drawing Title		修訂編號 Revision No.											
J837-CW-2302	位置圖	46	-											
J837-CW-2303	位置圖	47	-											
J837-CW-2304	位置圖	48	-											
J837-CW-2305	位置圖	49	-											
J837-CW-2306	位置圖	50	-											
J837-CW-2307	位置圖	51	-											
J837-CW-2308	位置圖	52	-											
J837-CW-2309	位置圖	53	-											
J837-CW-2310	位置圖	54	-											
J837-CW-2311	位置圖	55	-											
J837-CW-2312	位置圖	56	-											
J837-CW-2501	位置圖	57	-											
J837-CW-2502	位置圖	58	-											
J837-CW-2503	位置圖	59	-											
J837-CW-2504	位置圖	60	-											
J837-CW-2505	位置圖	61	-											
J837-CW-2506	位置圖	62	-											
J837-CW-2507	位置圖	63	-											
J837-CW-2508	位置圖	64	-											
J837-CW-2509	位置圖	65	-											
J837-CW-2510	位置圖	66	-											
J837-CW-2511	位置圖	67	-											
J837-CW-2512	位置圖	68	-											



美特鋁質有限公司
MIDI Aluminium Fabricator Ltd.

類別		物料號	
制圖	陳俊賢	2018.10.23	圖號 837-BD01
修改			
日期			
復核	謝永林	2018.11.06	數量 19039
批准			位置

雙主企鋁碼:(每個雙主企鋁碼有一個固定碼)
280(左)+327(右)+184.32(中間固定碼)=19039

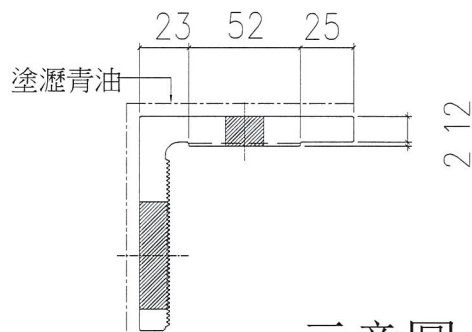
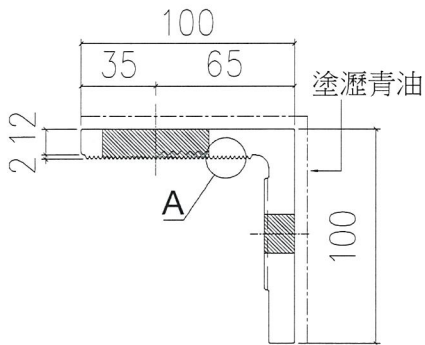
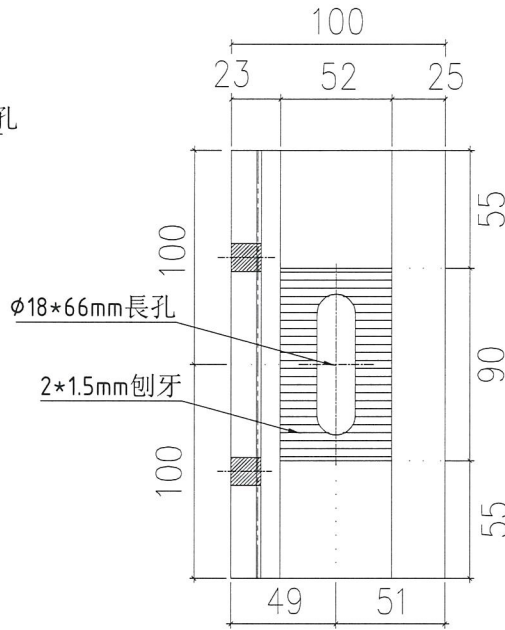
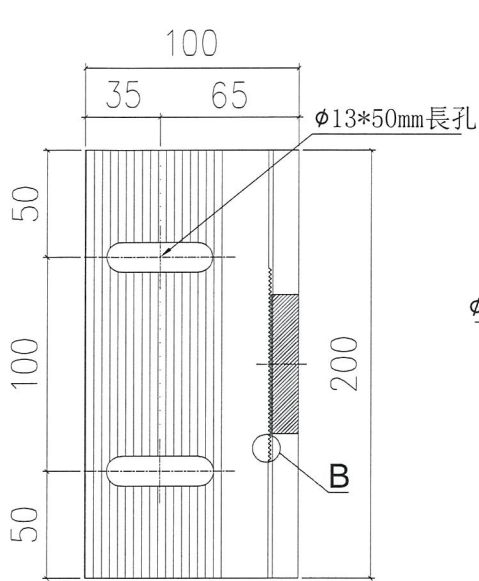

示意圖

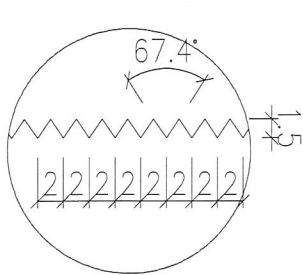

A
SCALE 6:1

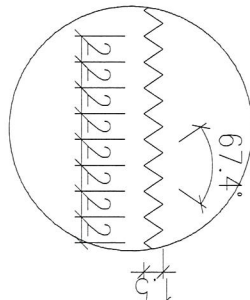

B
SCALE 6:1

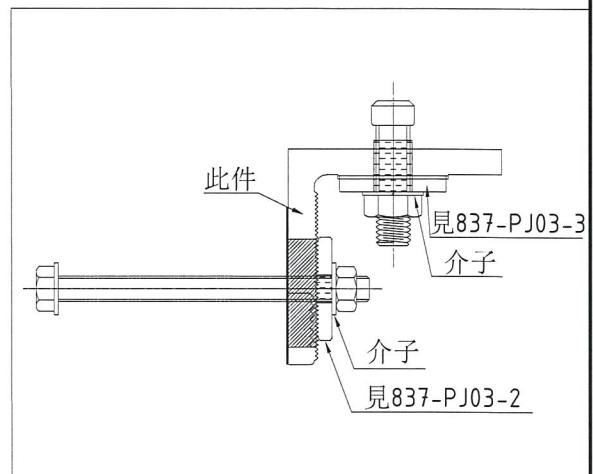

工程號	J-837	地盤	觀塘裕民坊
名稱	固定鋁碼加工圖	採用	
材料	X85592	地盤	✓
顏色	MILL+瀝青油	工廠	

附件

P.1



 美特鋁質有限公司 MIDI Aluminium Fabricator Ltd.	類別		物料號	
	制圖	陳俊賢	2018.10.23	圖號 837-PJ03
修改				數量 17362
日期			批准	位置

每個邊靠邊鐵碼用2個
 每個轉角鐵碼用2個
 每個雙主企鐵碼用4個

企料位

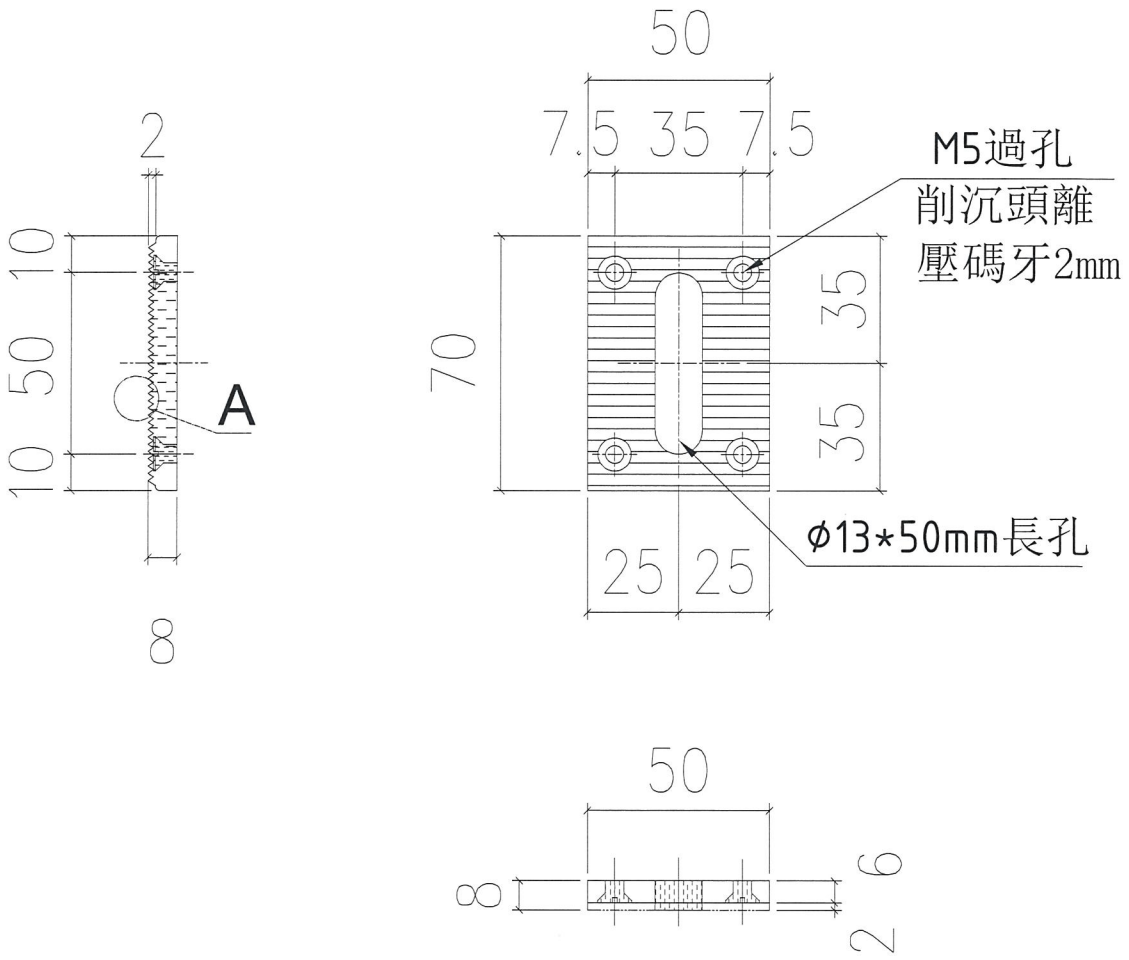

5974 (左靠邊鐵碼) + 5530 (右靠邊鐵碼) + 1330 (左靠邊大鐵碼)
 + 1820 (右靠邊大鐵碼) + 1120 (左雙主企鐵碼) + 1308 (左雙主企鐵碼) + 280 (轉角鐵碼) = 17362

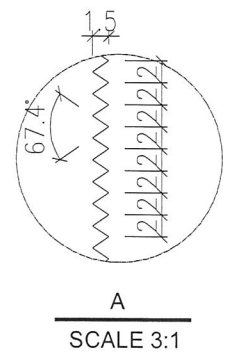

工程號	J-837	地盤	觀塘裕民坊	附 件
名稱	85鋁巴	採用		
材料	X85593	地盤		
顏色	MILL	工廠	✓	

P.2

 美特鋁質有限公司 MIDI Aluminium Fabricator Ltd.	類別	物料號		
	制圖 陳俊賢	2018.10.23	圖號	837-PJ03-1
修改	復核 謝永林	2018.11.06	數量	15401
日期	批准		位置	

每個邊靠邊鐵碼用2個
 每個轉角鐵碼用1個
 每個雙主企鐵碼用1個

channel / 絲杆位

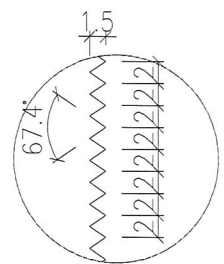
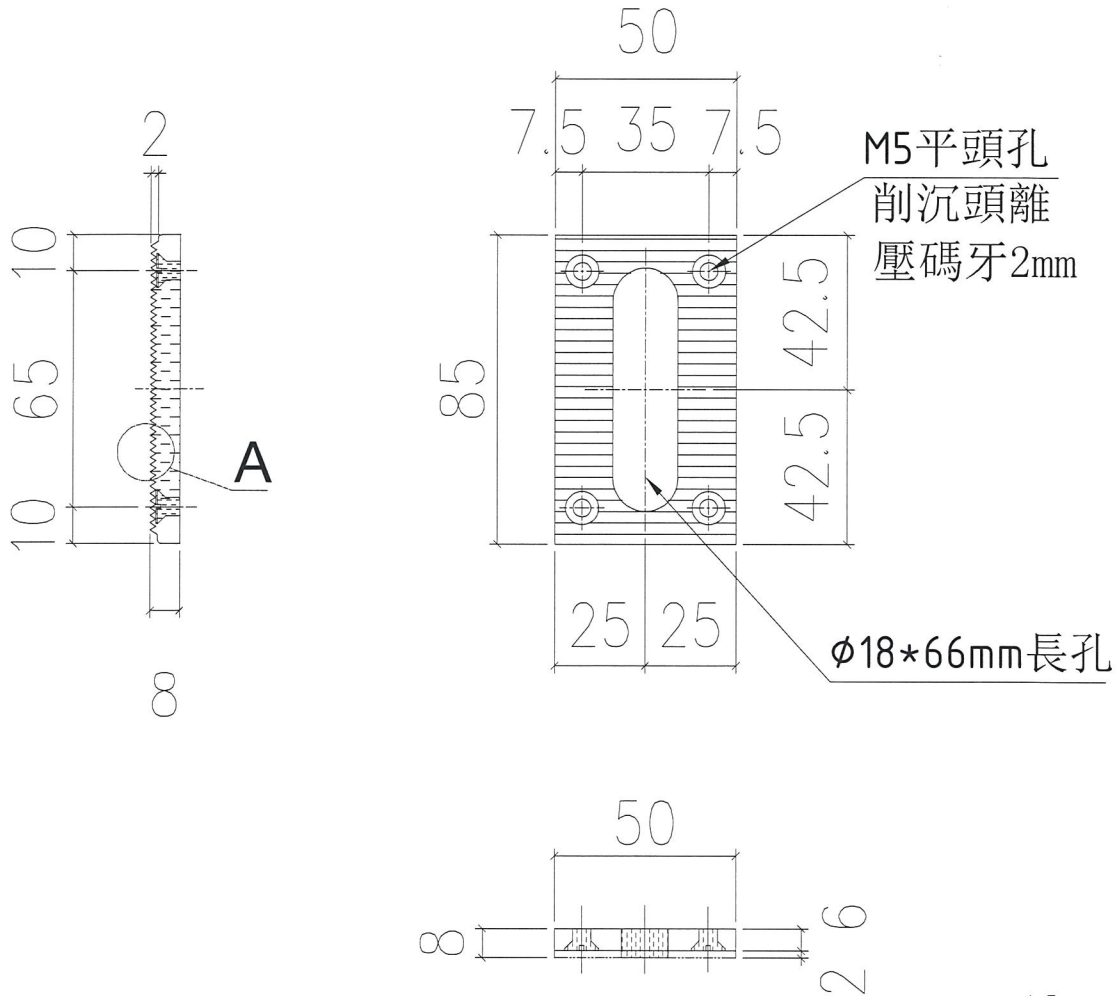

A
SCALE 3:1

靠邊鐵碼待香港地盤指示! 其實它鐵碼在廠收

5974 (左靠邊鐵碼) + 5530 (右靠邊鐵碼) + 1330 (左靠邊大鐵碼)
 + 1820 (右靠邊大鐵碼) + 280 (左雙主企鐵碼) + 327 (左雙主企鐵碼) + 140 (轉角鐵碼) = 15401 *3757*

工程號	J-837	地盤	觀塘裕民坊	附 件
名稱	85鋁巴	採用		
材料	X85593	地盤		
顏色	MILL	工廠		

P.3

 美特鋁質有限公司 MIDI Aluminium Fabricator Ltd.		類別	物料號		
修改		制圖 陳俊賢	2018.10.23	圖號	837-PJ03-02
日期		復核 謝永林	2018.11.06	數量	-
		批准		位置	

編號: PJ03-02

數量: 55440

在料位 每個邊靠邊鐵碼用2個
 每個轉角鐵碼用2個
 每個雙主企鐵碼用4個
 每個固定鋁碼用2個

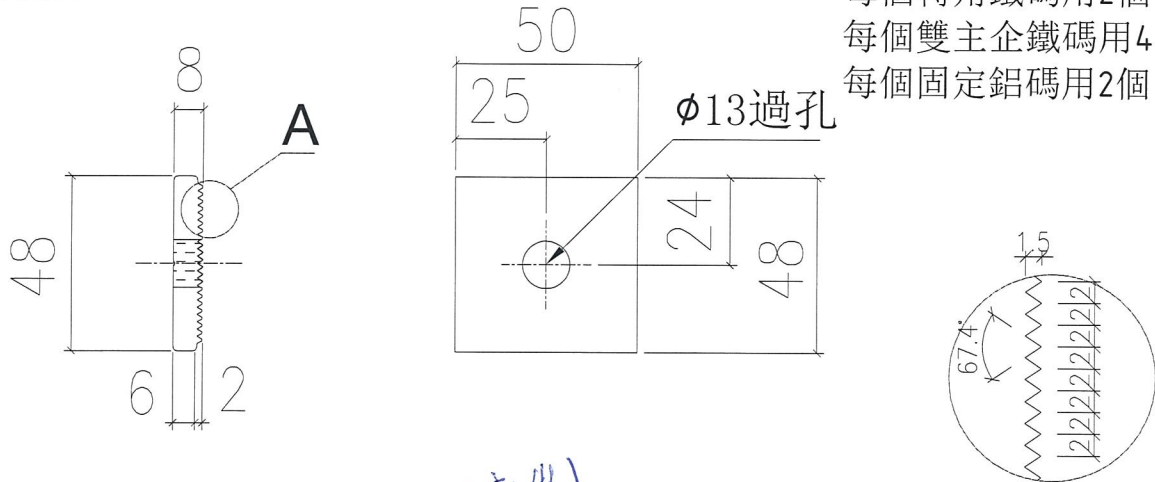

鋁碼地盤安裝! 其它鐵碼待香港地盤指示 (*廠裝*)

5974(左靠邊鐵碼)+5530(右靠邊鐵碼)+1330(左靠邊大鐵碼)
 +1820(右靠邊大鐵碼)+1120(左雙主企鐵碼)+1308(左雙主企鐵碼)
 +280(轉角鐵碼)+38078(鋁碼)=55440

A
SCALE 3:1

地盤

編號: PJ03-03

數量: 34440

*34440 = 2987*2 + 2765*2*

Channel / 在料位 每個邊靠邊鐵碼用2個
 每個轉角鐵碼用1個
 每個雙主企鐵碼用1個
 每個固定鋁碼用1個

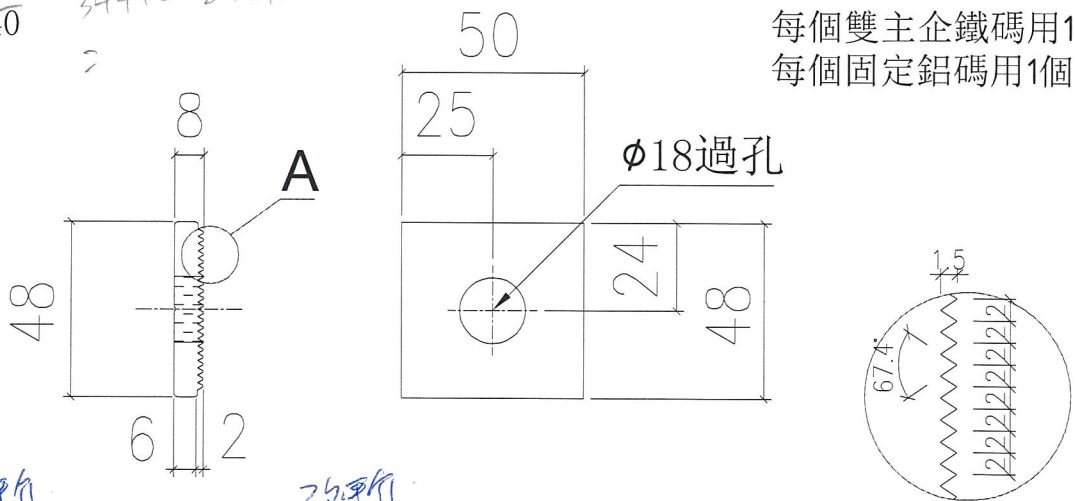

改平角 5974(左靠邊鐵碼)+5530(右靠邊鐵碼)+1330(左靠邊大鐵碼)
 +1820(右靠邊大鐵碼)+280(左雙主企鐵碼)+327(左雙主企鐵碼)
 +140(轉角鐵碼)+19039(鋁碼)=34440 *22796*

A
SCALE 3:1

工程號	J-837	地盤	觀塘裕民坊	附 件
名稱	48鋁介子	採用		
材料	-	地盤		
顏色	MILL	工廠		

P.4

 美特鋁質有限公司 MIDI Aluminium Fabricator Ltd.		類別	物料號	
修改		制圖	陳俊賢	2018.10.23
日期		復核	謝永林	2018.11.06
		批准		
			圖號	837-PJ03-4
			數量	7327
			位置	

2987(左靠邊鐵碼)+2765(右靠邊鐵碼)+665(左靠邊大鐵碼)
 +910(右靠邊大鐵碼)=7327

廠修 (在料內絕)

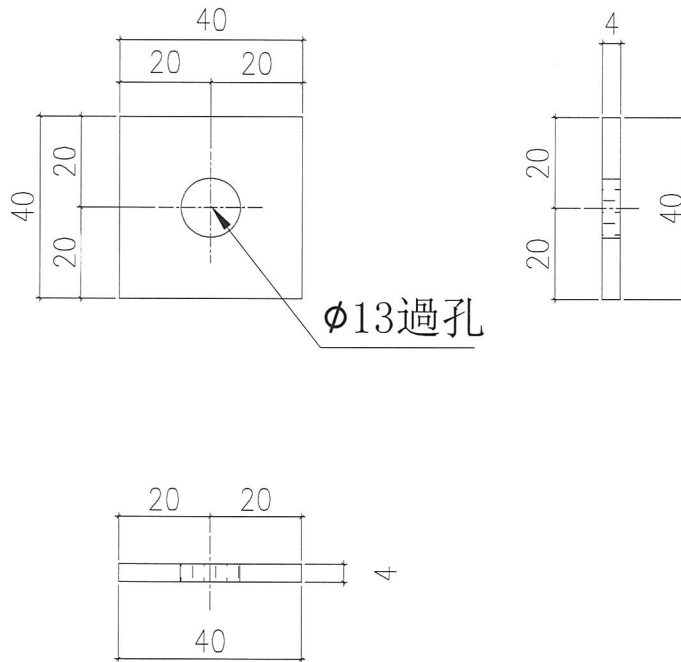

待香港地盤指示在地盤還是廠收

每個靠邊鐵碼用1個

工程號	J-837	地盤	觀塘裕民坊	附件 P.5
名稱	40鋁介子		採用	
材料	4mm鋁巴		地盤	
顏色	MILL		工廠	

 美特鋁質有限公司 MIDI Aluminium Fabricator Ltd.		類別	物料號		
修改		制圖 陳俊賢	2018.10.23	圖號	837-DL01
日期		復核 謝永林	2018.11.06	數量	-
		批准		位置	

2987

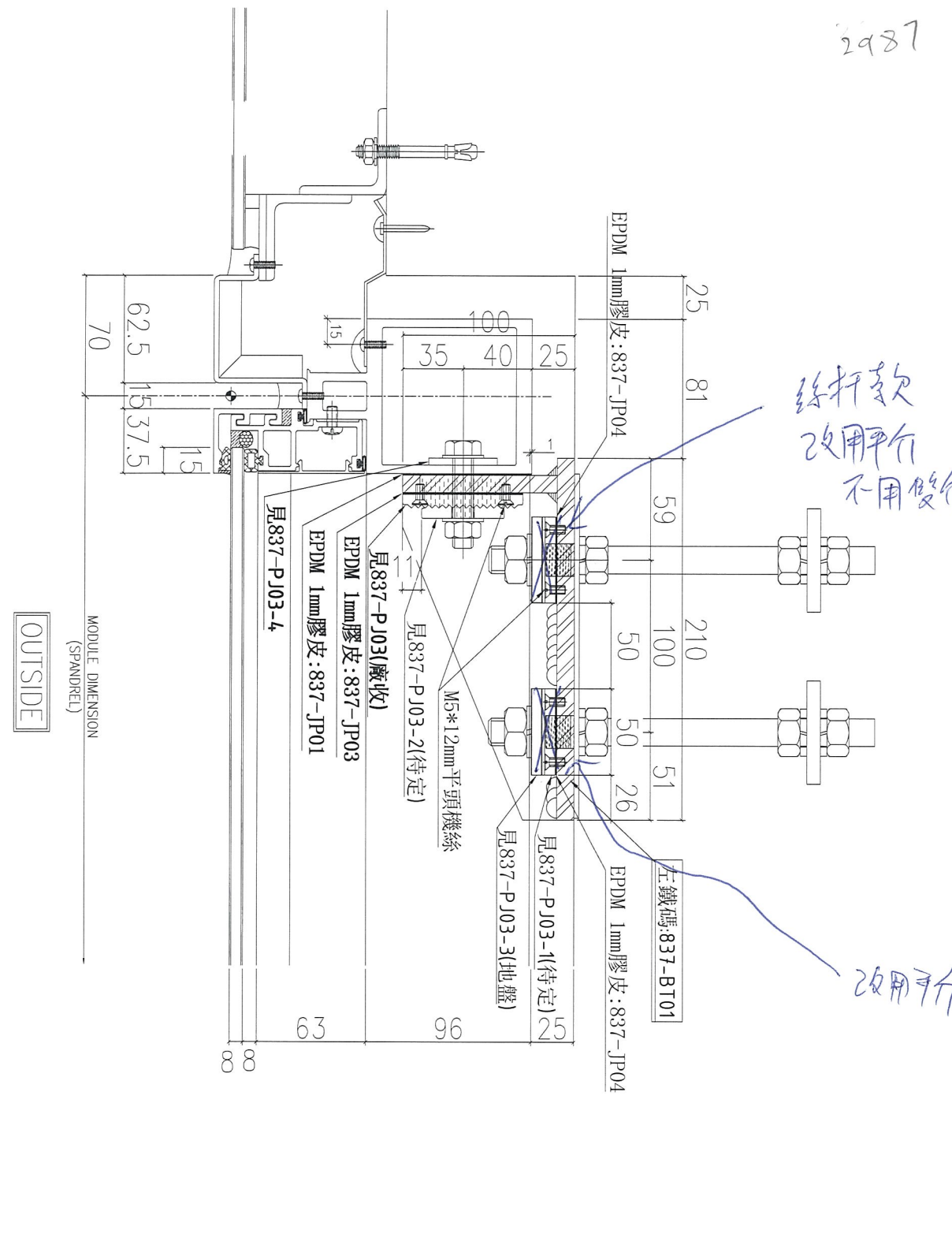

使用位置見後頁

工程號	J-837	地盤	觀塘裕民坊	附 件
名稱	鐵碼組裝鋁件安裝示意圖		採用	
材料	-	地盤		
顏色	-	工廠		

P.6



美特鋁質有限公司
MIDI Aluminium Fabricator Ltd.

類別		物料號	
制圖	陳俊賢	2018.10.23	圖號 837-DL01(1)
復核	謝永林	2018.11.06	數量 -
批准			位置

修改			
日期			

使用位置	數量	層數	總數	樓層
T1CWH-1	1	35	35	8/F-26/F,29/F-49/F
T1CWG-2	1	35	35	8/F-26/F,29/F-49/F
T1CWG-1	3	35	105	8/F-26/F,29/F-49/F
T1CWF-2	1	35	35	8/F-26/F,29/F-49/F
T1CWE-1	1	35	35	8/F-26/F,29/F-49/F
T1CWD-1	2	35	70	8/F-26/F,29/F-49/F
T1CWA-3	1	35	35	8/F-26/F,29/F-49/F
T1CWA-1	2	35	70	8/F-26/F,29/F-49/F
T1CWB-3	1	35	35	8/F-26/F,29/F-49/F
T1CWB-2	1	35	35	8/F-26/F,29/F-49/F
T1CWB-1	1	35	35	8/F-26/F,29/F-49/F
T1CWC-1	1	35	35	8/F-26/F,29/F-49/F
T1CWM-2	1	35	35	8/F-26/F,29/F-49/F
T1CWL-2	1	35	35	8/F-26/F,29/F-49/F
T1CWL-1	1	35	35	8/F-26/F,29/F-49/F
T1CWK-2	1	35	35	8/F-26/F,29/F-49/F
T1CWJ-2	1	35	35	8/F-26/F,29/F-49/F
T1CWJ-1	1	35	35	8/F-26/F,29/F-49/F
T1CWH-2	1	35	35	8/F-26/F,29/F-49/F
T1CWH-1	1	35	35	8/F-26/F,29/F-49/F
T1CWG-2	2	35	70	8/F-26/F,29/F-49/F
T1CWF-2	1	35	35	8/F-26/F,29/F-49/F
T1CWE-2	1	35	35	8/F-26/F,29/F-49/F
T1CWD-1	1	35	35	8/F-26/F,29/F-49/F
T1CWC-1	1	35	35	8/F-26/F,29/F-49/F
T1CWB-2	1	35	35	8/F-26/F,29/F-49/F
T1CWB-1	1	35	35	8/F-26/F,29/F-49/F
T1CWA-2	1	35	35	8/F-26/F,29/F-49/F
T1CWA-1	2	35	70	8/F-26/F,29/F-49/F
T1CWN-2	1	35	35	8/F-26/F,29/F-49/F
T1CWN-1	1	35	35	8/F-26/F,29/F-49/F
T1CWM-3	1	35	35	8/F-26/F,29/F-49/F
T1CWM-2	1	35	35	8/F-26/F,29/F-49/F
T1CWM-1	1	35	35	8/F-26/F,29/F-49/F
T1CWL-2	1	35	35	8/F-26/F,29/F-49/F
T1CWL-1	1	35	35	8/F-26/F,29/F-49/F
T1CWJ-1	1	35	35	8/F-26/F,29/F-49/F

使用位置	數量	層數	總數	樓層
T2CWH-2	1	35	35	8/F-26/F,29/F-49/F
T2CWF-1	1	35	35	8/F-26/F,29/F-49/F
T2CWE-1	2	35	70	8/F-26/F,29/F-49/F
T2CWM-2	1	35	35	8/F-26/F,29/F-49/F
T2CWL-2	1	35	35	8/F-26/F,29/F-49/F
T2CWL-1	1	35	35	8/F-26/F,29/F-49/F
T2CWK-2	1	35	35	8/F-26/F,29/F-49/F
T2CWL-2	1	35	35	8/F-26/F,29/F-49/F
T2CWA-2	1	35	35	8/F-26/F,29/F-49/F
T2CWA-1	2	35	70	8/F-26/F,29/F-49/F
T2CWD-1	1	35	35	8/F-26/F,29/F-49/F
T2CWC-1	1	35	35	8/F-26/F,29/F-49/F
T2CWB-2	1	35	35	8/F-26/F,29/F-49/F
T2CWB-1	1	35	35	8/F-26/F,29/F-49/F
T2CWM-1	1	35	35	8/F-26/F,29/F-49/F
T2CWL-2	1	35	35	8/F-26/F,29/F-49/F
T2CWL-1	1	35	35	8/F-26/F,29/F-49/F
T2CWD-1	1	35	35	8/F-26/F,29/F-49/F
T2CWC-1	2	35	70	8/F-26/F,29/F-49/F
T2CWH-3	1	35	35	8/F-26/F,29/F-49/F
T2CWH-2	1	35	35	8/F-26/F,29/F-49/F
T2CWH-1	1	35	35	8/F-26/F,29/F-49/F
T2CWG-2	1	35	35	8/F-26/F,29/F-49/F
T2CWF-2	1	35	35	8/F-26/F,29/F-49/F
T2CWF-1	1	35	35	8/F-26/F,29/F-49/F
T2CWE-2	1	35	35	8/F-26/F,29/F-49/F
T2CWE-1	1	35	35	8/F-26/F,29/F-49/F
T2CWD-2	1	35	35	8/F-26/F,29/F-49/F
T2CWD-1	1	35	35	8/F-26/F,29/F-49/F
T2CWA-3	1	35	35	8/F-26/F,29/F-49/F
T2CWA-1	1	35	35	8/F-26/F,29/F-49/F
T2CWC-1	1	12	12	8/F-21/F
合計			2987	

加工圖參見:837-DL01

工程號	J-837	地盤	觀塘裕民坊
名稱	鐵碼組裝鋁件安裝示意圖(數據表)		
材料	-	採用	地盤
顏色	-		工廠

附件

P.7

 美特鋁質有限公司 MIDI Aluminium Fabricator Ltd.		類別	物料號		
修改		制圖 陳俊賢	2018.10.23	圖號	837-DL02
日期		復核 謝永林	2018.11.06	數量	-
		批准		位置	

2765

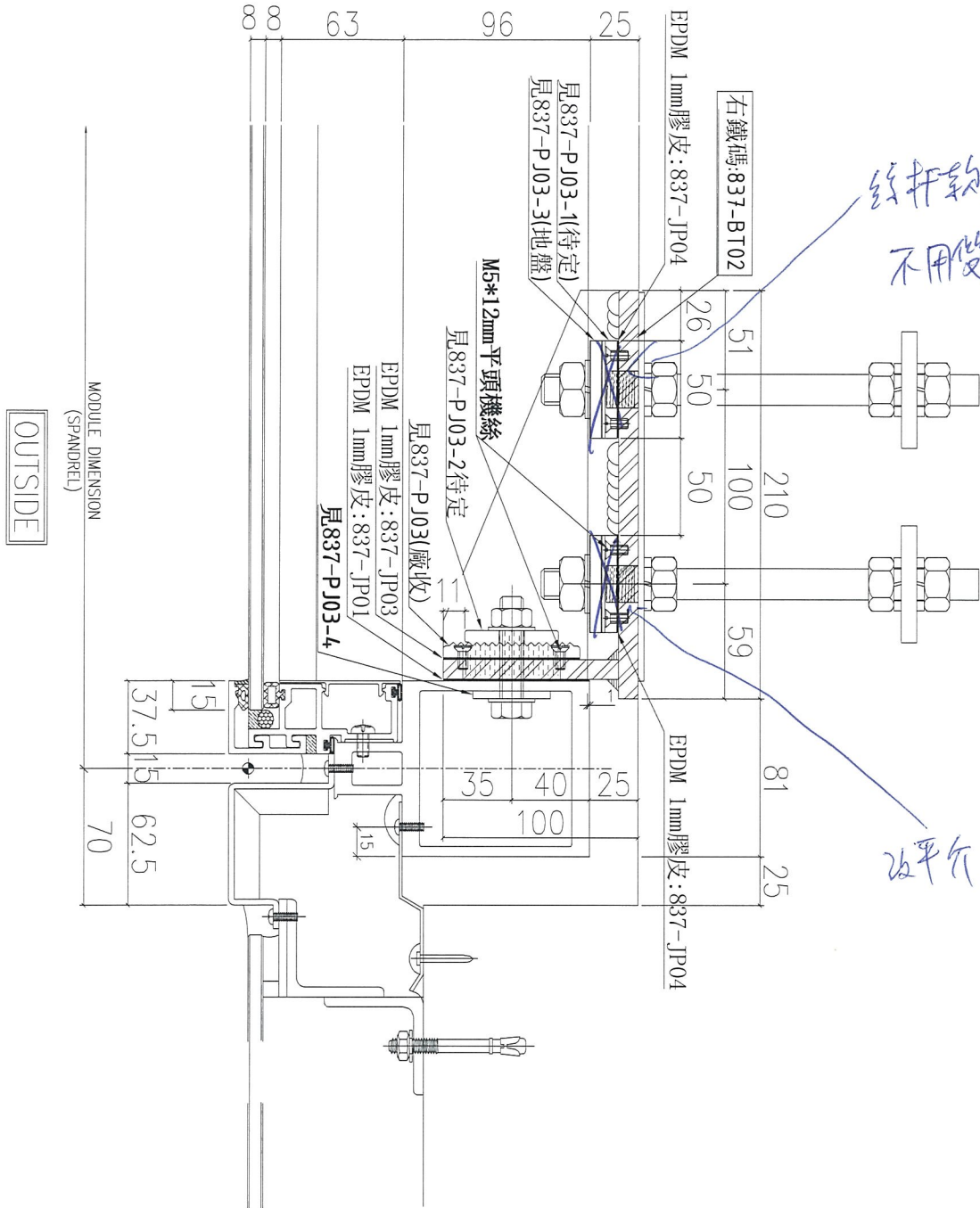

螺打軟改平介
不用雙介子

改平介

使用位置見後頁

P.8

工程號	J-837	地盤	觀塘裕民坊	附 件
名稱	鐵碼組裝鋁件安裝示意圖		採用	
材料	-	地盤		
顏色	-	工廠		



美特鋁質有限公司
MIDI Aluminium Fabricator Ltd.

類別		物料號	
制圖	陳俊賢	2018.10.23	圖號 837-DL02(1)
復核	謝永林	2018.11.06	數量 -
批准			位置

修改			
日期			

使用位置	數量	層數	總數	樓層
T1CWH-1	1	35	35	8/F-26/F,29/F-49/F
T1CWH-2	1	35	35	8/F-26/F,29/F-49/F
T1CWF-2	1	35	35	8/F-26/F,29/F-49/F
T1CWE-2	1	35	35	8/F-26/F,29/F-49/F
T1CWD-1	2	35	70	8/F-26/F,29/F-49/F
T1CWA-3	1	35	35	8/F-26/F,29/F-49/F
T1CWA-2	1	35	35	8/F-26/F,29/F-49/F
T1CWA-1	1	35	35	8/F-26/F,29/F-49/F
T1CWB-3	1	35	35	8/F-26/F,29/F-49/F
T1CWC-1	2	35	70	8/F-26/F,29/F-49/F
T1CWM-2	1	35	35	8/F-26/F,29/F-49/F
T1CWM-1	1	35	35	8/F-26/F,29/F-49/F
T1CWL-1	1	35	35	8/F-26/F,29/F-49/F
T1CWK-2	1	35	35	8/F-26/F,29/F-49/F
T1CWK-1	1	35	35	8/F-26/F,29/F-49/F
T1CWJ-1	1	35	35	8/F-26/F,29/F-49/F
T1CWH-2	2	35	70	8/F-26/F,29/F-49/F
T2CWH-1	1	35	35	8/F-26/F,29/F-49/F
T2CWG-2	1	35	35	8/F-26/F,29/F-49/F
T2CWF-2	1	35	35	8/F-26/F,29/F-49/F
T2CWF-1	1	35	35	8/F-26/F,29/F-49/F
T2CWE-1	1	35	35	8/F-26/F,29/F-49/F
T2CWD-1	1	35	35	8/F-26/F,29/F-49/F
T2CWC-1	1	35	35	8/F-26/F,29/F-49/F
T2CWB-2	2	35	70	8/F-26/F,29/F-49/F
T2CWB-1	1	35	35	8/F-26/F,29/F-49/F
T2CWA-2	1	35	35	8/F-26/F,29/F-49/F
T2CWA-1	1	35	35	8/F-26/F,29/F-49/F
T2CWN-1	1	35	35	8/F-26/F,29/F-49/F
T2CWM-3	2	35	70	8/F-26/F,29/F-49/F
T2CWL-2	1	35	35	8/F-26/F,29/F-49/F
T2CWL-1	1	35	35	8/F-26/F,29/F-49/F
T2CWH-2	1	35	35	8/F-26/F,29/F-49/F
T3CWF-1	1	35	35	8/F-26/F,29/F-49/F
T3CWE-1	1	35	35	8/F-26/F,29/F-49/F
T3CWM-2	1	35	35	8/F-26/F,29/F-49/F

使用位置	數量	層數	總數	樓層
T3CWM-1	1	35	35	8/F-26/F,29/F-49/F
T3CWL-1	1	35	35	8/F-26/F,29/F-49/F
T3CWK-2	1	35	35	8/F-26/F,29/F-49/F
T3CWK-1	1	35	35	8/F-26/F,29/F-49/F
T3CWJ-2	1	35	35	8/F-26/F,29/F-49/F
T3CWJ-1	1	35	35	8/F-26/F,29/F-49/F
T3CWH-2	1	35	35	8/F-26/F,29/F-49/F
T3CWH-1	1	35	35	8/F-26/F,29/F-49/F
T3CWC-1	1	35	35	8/F-26/F,29/F-49/F
T3CWB-2	2	35	70	8/F-26/F,29/F-49/F
T3CWB-1	1	35	35	8/F-26/F,29/F-49/F
T3CWA-2	1	35	35	8/F-26/F,29/F-49/F
T3CWA-1	1	35	35	8/F-26/F,29/F-49/F
T3CWD-1	1	35	35	8/F-26/F,29/F-49/F
T3CWG-1	1	35	35	8/F-26/F,29/F-49/F
T3CWF-2	2	35	70	8/F-26/F,29/F-49/F
T5CWA-2	1	35	35	8/F-26/F,29/F-49/F
T5CWN-1	1	35	35	8/F-26/F,29/F-49/F
T5CWM-2	1	35	35	8/F-26/F,29/F-49/F
T5CWM-1	1	35	35	8/F-26/F,29/F-49/F
T5CWL-2	1	35	35	8/F-26/F,29/F-49/F
T5CWL-1	1	35	35	8/F-26/F,29/F-49/F
T5CWJK-1	2	35	70	8/F-26/F,29/F-49/F
T5CWH-3	1	35	35	8/F-26/F,29/F-49/F
T5CWH-1	1	35	35	8/F-26/F,29/F-49/F
T5CWG-2	1	35	35	8/F-26/F,29/F-49/F
T5CWG-1	1	35	35	8/F-26/F,29/F-49/F
T5CWF-1	1	35	35	8/F-26/F,29/F-49/F
T5CWE-2	1	35	35	8/F-26/F,29/F-49/F
T5CWE-1	1	35	35	8/F-26/F,29/F-49/F
T5CWD-1	1	35	35	8/F-26/F,29/F-49/F
T5CWC-1	1	35	35	8/F-26/F,29/F-49/F
T5CWC-1	1	35	35	8/F-26/F,29/F-49/F
T5CWA-3	1	35	35	8/F-26/F,29/F-49/F

合計 2765

加工圖參見:837-DL02

工程號	J-837	地盤	觀塘裕民坊
名稱	鐵碼組裝鋁件安裝示意圖(數據表)		
材料	-	採用	地盤
顏色	-		工廠

附件

P.9

 美特鋁質有限公司 MIDI Aluminium Fabricator Ltd.		類別	物料號	
修改		制圖 陳俊賢	2018.10.23	圖號 837-DL03
日期		復核 謝永林	2018.11.06	數量 -
		批准		位置

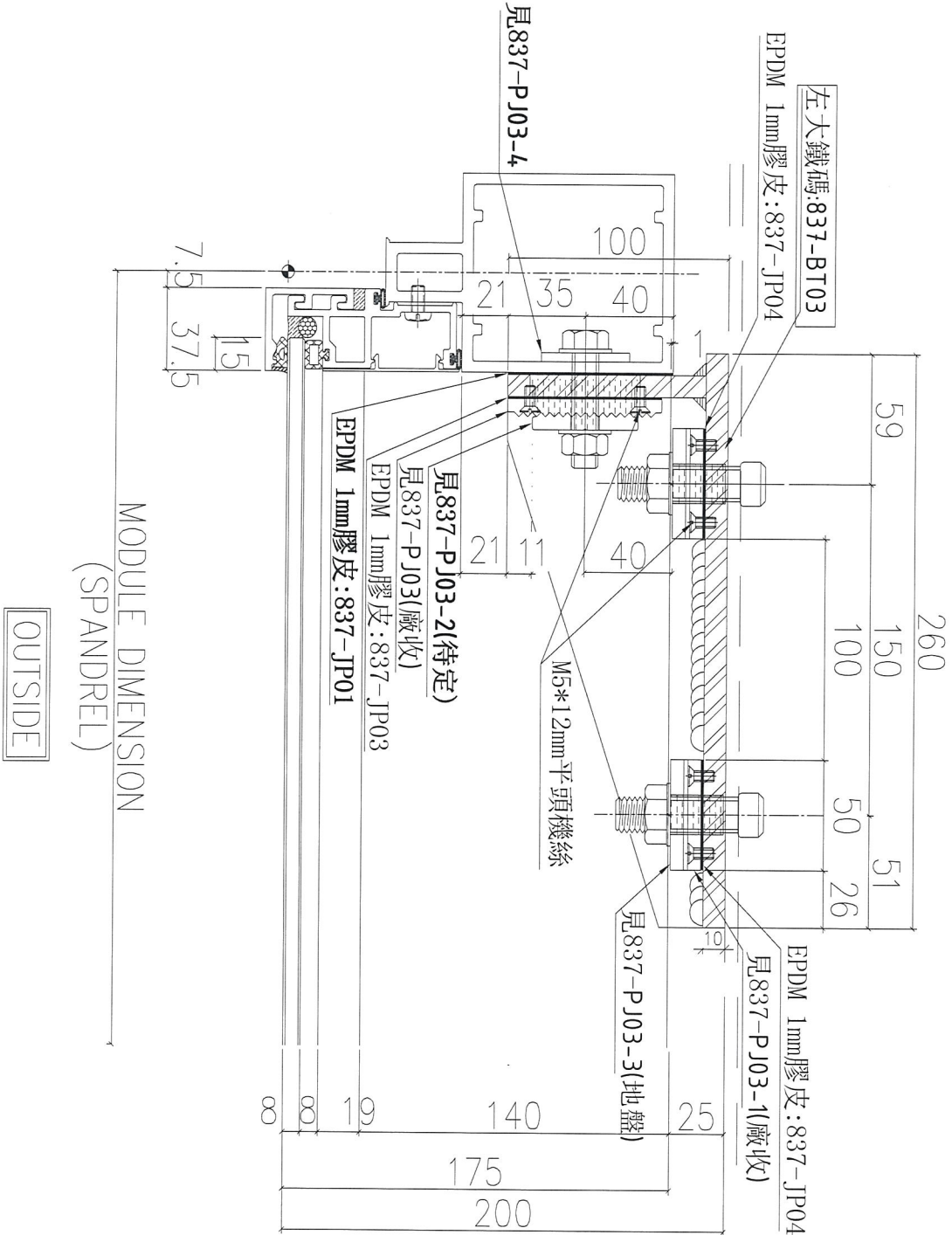

使用位置見後頁

工程號	J-837	地盤	觀塘裕民坊
名稱	大鐵碼組裝鋁件安裝示意圖		採用
材料	-	地盤	
顏色	-	工廠	

附件

P.10

 美特鋁質有限公司 MIDI Aluminium Fabricator Ltd.				類別	物料號			
				制圖	陳俊賢	2018.10.23	圖號	837-DL03(1)
修改				復核	謝永林	2018.11.06	數量	-
日期				批准			位置	

使用位置	數量	層數	總數	樓層
T1CWE-2	1	35	35	8/F-26/F,29/F-49/F
T1CWA-2	1	35	35	8/F-26/F,29/F-49/F
T1CWM-1	1	35	35	8/F-26/F,29/F-49/F
T1CWK-1	1	35	35	8/F-26/F,29/F-49/F
T2CWF-1	1	35	35	8/F-26/F,29/F-49/F
T2CWM-3	1	35	35	8/F-26/F,29/F-49/F
T2CWL-1	1	35	35	8/F-26/F,29/F-49/F
T2CWK-2	1	35	35	8/F-26/F,29/F-49/F
T2CWK-1	1	35	35	8/F-26/F,29/F-49/F
T3CWM-1	1	35	35	8/F-26/F,29/F-49/F
T3CWK-1	1	35	35	8/F-26/F,29/F-49/F
T3CWJ-1	1	35	35	8/F-26/F,29/F-49/F
T3CWH-3	1	35	35	8/F-26/F,29/F-49/F
T3CWH-1	1	35	35	8/F-26/F,29/F-49/F
T3CWF-2	1	35	35	8/F-26/F,29/F-49/F
T5CWM-2	1	35	35	8/F-26/F,29/F-49/F
T5CWG-1	1	35	35	8/F-26/F,29/F-49/F
T5CWE-1	1	35	35	8/F-26/F,29/F-49/F
T3CWD-1	1	35	35	8/F-26/F,29/F-50/F
合計	665			

加工圖參見:837-DL03

工程號	J-837	地盤	觀塘裕民坊	附 件	P.11
名稱	大鐵碼組裝鋁件安裝示意圖(數據表)		採用		
材料	-		地盤		
顏色	-		工廠		

 美特鋁質有限公司 MIDI Aluminium Fabricator Ltd.		類別	物料號	
修改		制圖 陳俊賢	2018.10.23	圖號 837-DL04
日期		復核 謝永林	2018.11.06	數量 -
		批准		位置

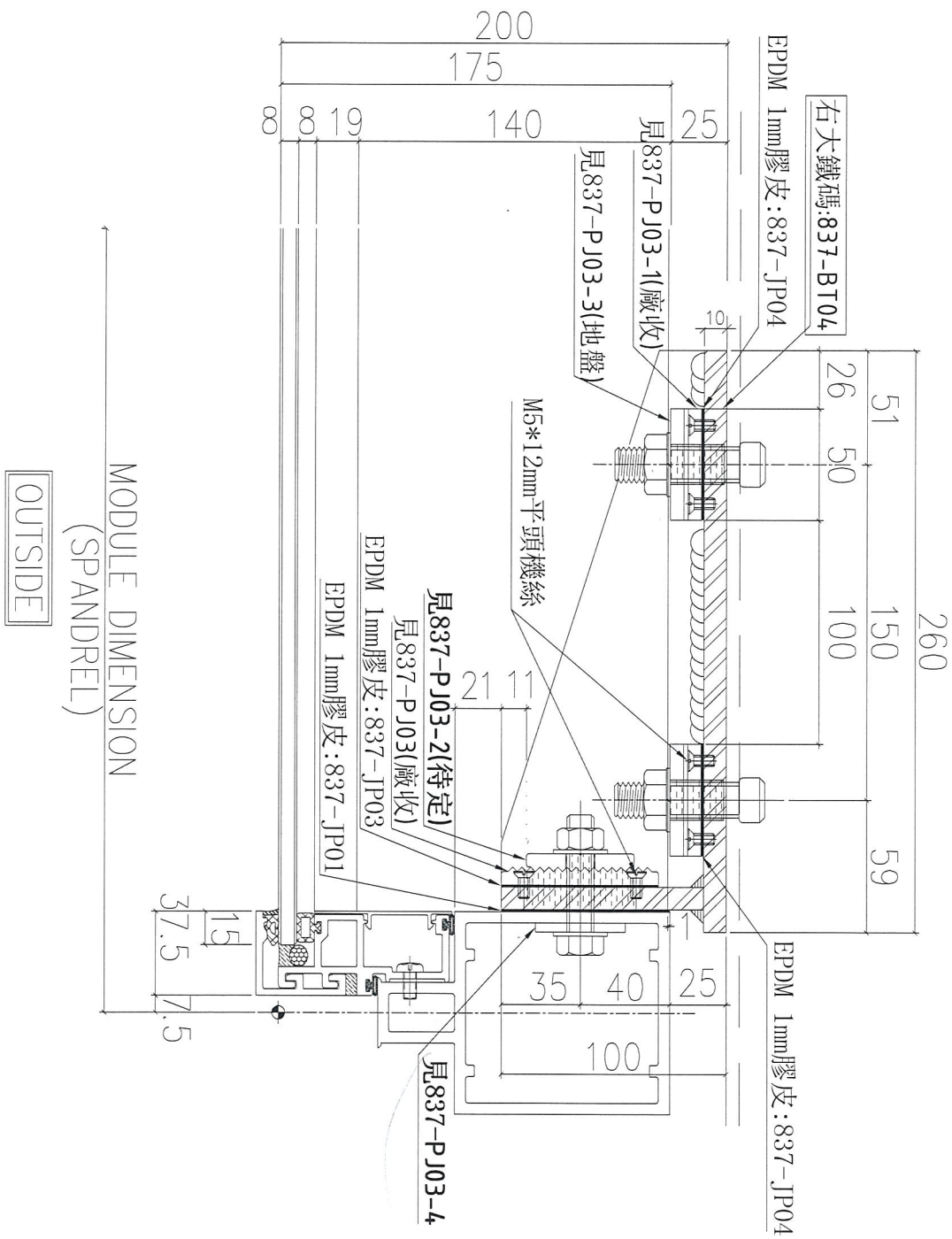

使用位置見後頁

工程號	J-837	地盤	觀塘裕民坊
名稱	大鐵碼組裝鋁件安裝示意圖	採用	
材料	-	地盤	
顏色	-	工廠	

附件

P.12

 美特鋁質有限公司 MIDI Aluminium Fabricator Ltd.				類別		物料號		
修改				制圖	陳俊賢	2018.10.23	圖號	837-DL04(1)
日期				復核	謝永林	2018.11.06	數量	-
				批准			位置	

使用位置	數量	層數	總數	樓層
T1CWG-1	1	35	35	8/F-26/F,29/F-49/F
T1CWF-2	2	35	70	8/F-26/F,29/F-49/F
T1CWE-1	1	35	35	8/F-26/F,29/F-49/F
T1CWD-1	1	35	35	8/F-26/F,29/F-49/F
T1CWB-2	1	35	35	8/F-26/F,29/F-49/F
T1CWB-1	1	35	35	8/F-26/F,29/F-49/F
T1CWL-2	1	35	35	8/F-26/F,29/F-49/F
T1CWJ-2	1	35	35	8/F-26/F,29/F-49/F
T2CWG-2	1	35	35	8/F-26/F,29/F-49/F
T2CWE-2	1	35	35	8/F-26/F,29/F-49/F
T2CWN-2	1	35	35	8/F-26/F,29/F-49/F
T2CWM-1	1	35	35	8/F-26/F,29/F-49/F
T2CWL-2	1	35	35	8/F-26/F,29/F-49/F
T2CWL-1	1	35	35	8/F-26/F,29/F-49/F
T2CWK-2	1	35	35	8/F-26/F,29/F-49/F
T2CWJ-1	3	35	105	8/F-26/F,29/F-49/F
T3CWL-2	1	35	35	8/F-26/F,29/F-49/F
T3CWC-2	1	35	35	8/F-26/F,29/F-49/F
T3CWG-1	1	35	35	8/F-26/F,29/F-49/F
T5CWA-1	1	35	35	8/F-26/F,29/F-49/F
T5CWJK-1	1	35	35	8/F-26/F,29/F-49/F
T5CWF-2	1	35	35	8/F-26/F,29/F-49/F
T5CWD-2	1	35	35	8/F-26/F,29/F-49/F
合計			910	

加工圖參見:837-DL04

工程號	J-837	地盤	觀塘裕民坊	附件
名稱	大鐵碼組裝鋁件安裝示意圖(數據表)		採用	
材料	-		地盤	
顏色	-		工廠	

P-13

 美特鋁質有限公司 MIDI Aluminium Fabricator Ltd.		類別	物料號	
修改		制圖 陳俊賢	2018.10.23	圖號 837-DL05
日期		復核 謝永林	2018.11.06	數量 -
		批准		位置

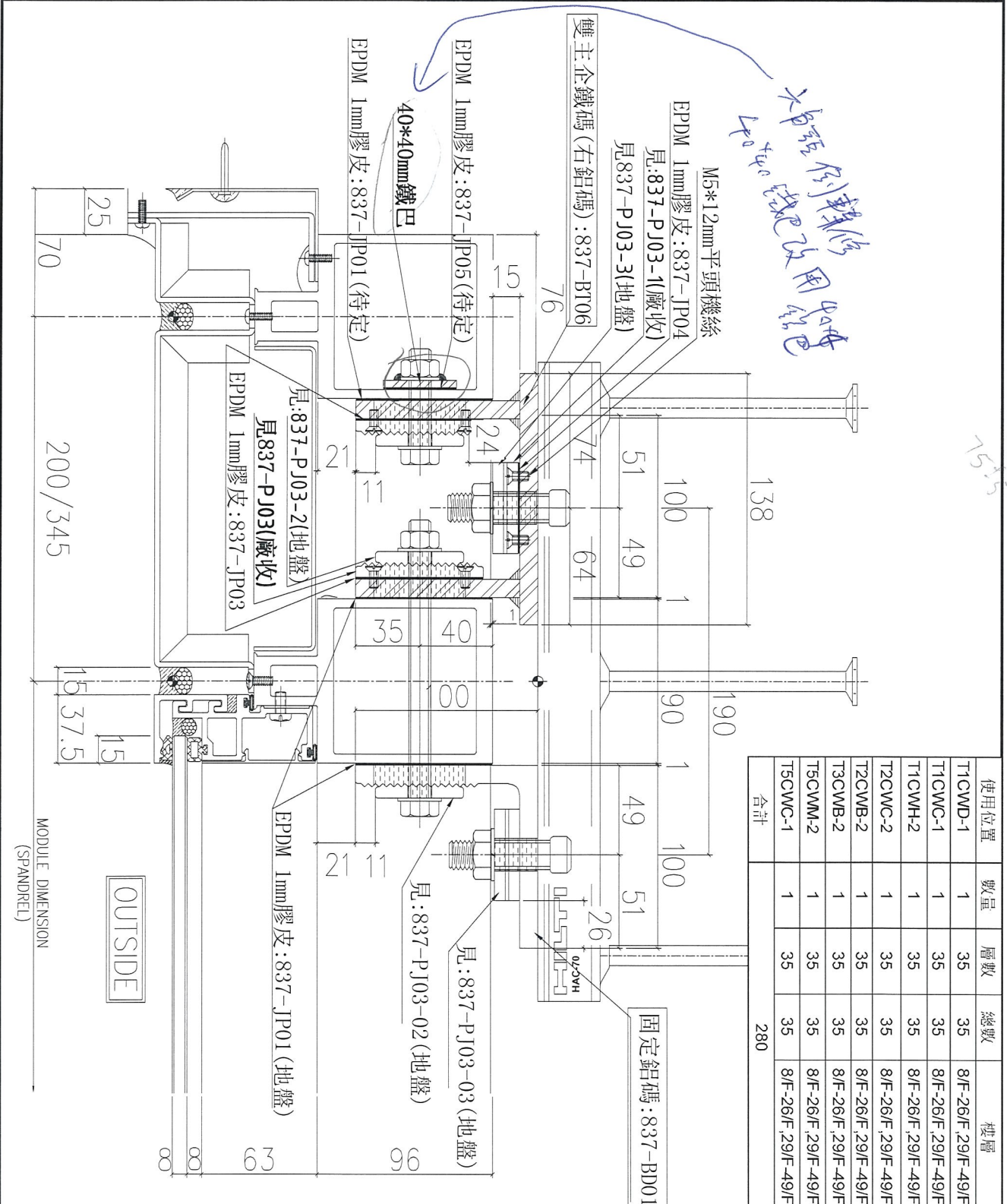

40*40mm鐵巴
 本窗系列維修用零件

837-5

15.5

工程號 J-837	地盤 觀塘裕民坊	附 件
名稱 雙主企鐵碼組裝鋁件安裝示意圖	採用	
材料 -	地盤	
顏色 -	工廠	

P.14

 美特鋁質有限公司 MIDI Aluminium Fabricator Ltd.		類別		物料號	
修改		制圖	陳俊賢	2018.10.23	圖號 837-DL07
日期		復核	謝永林	2018.11.06	數量 -
		批准			位置

使用位置	數量	層數	總數	樓層
T1CWB-1	1	35	35	8/F-26/F,29/F-49/F
T3CWH-3	1	35	35	8/F-26/F,29/F-49/F
合計			70	

取消雙介子, 改用平介

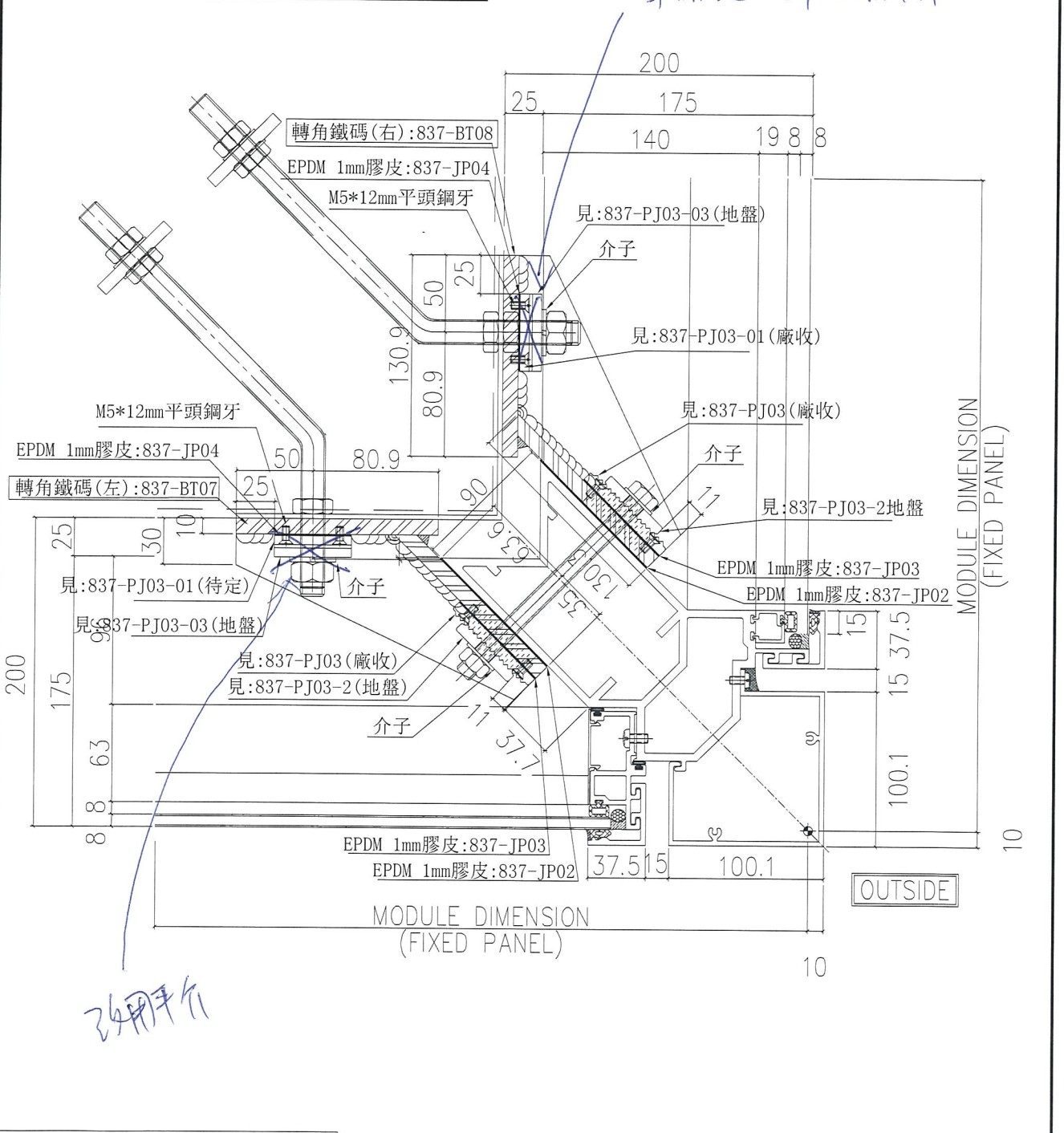

改用平介

轉角鐵碼組合左右各一個鐵碼

工程號	J-837	地盤	觀塘裕民坊
名稱	轉角鐵碼組裝鋁件安裝示意圖		採用
材料	-	地盤	
顏色	-	工廠	

附件

P.16

 美特鋁質有限公司 MIDI Aluminium Fabricator Ltd.	類別		物料號	
	制圖	陳俊賢	2018.10.23	圖號 837-AG01
修改		復核	謝永林	2018.11.06
日期		批准		數量 -
				位置

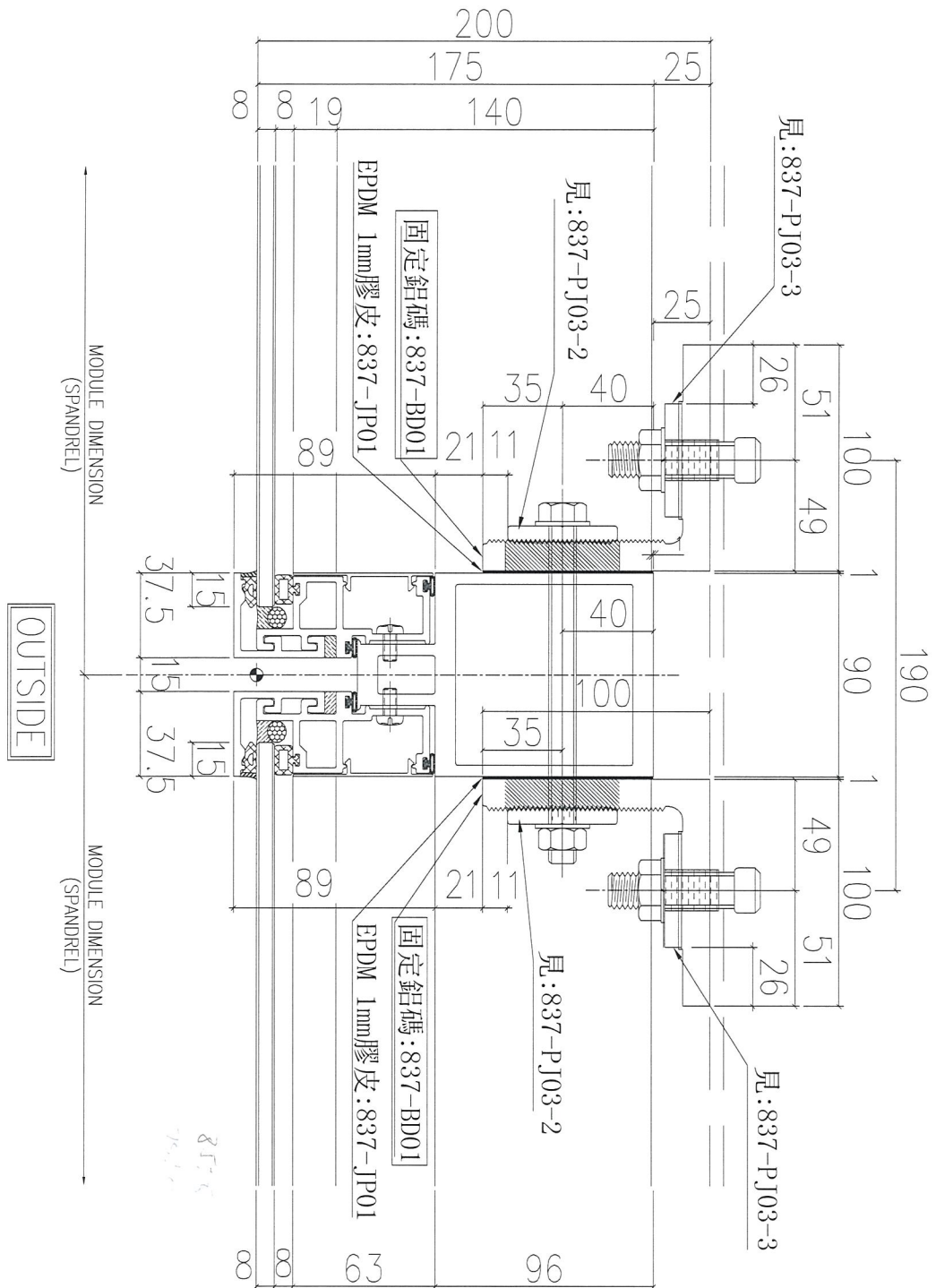

使用位置見後頁

工程號	J-837	地盤	觀塘裕民坊	附 件
名稱	固定鋁碼安裝示意圖		採用	
材料	-		地盤	
顏色	-		工廠	

P.17

 美特鋁質有限公司 MIDI Aluminium Fabricator Ltd.				類別		物料號		
修改				制圖	陳俊賢	2018.10.23	圖號	837-AG01(1)
日期				復核	謝永林	2018.11.06	數量	-
				批准			位置	

使用位置	數量	層數	總數	樓層
T1CWH-1	4	35	140	8/F-26/F,29/F-49/F
T1CWG-2	4	35	140	8/F-26/F,29/F-49/F
T1CWG-1	10	35	350	8/F-26/F,29/F-49/F
T1CWF-2	8	35	280	8/F-26/F,29/F-49/F
T1CWE-2	6	35	210	8/F-26/F,29/F-49/F
T1CWE-1	6	35	210	8/F-26/F,29/F-49/F
T1CWD-1	10	35	350	8/F-26/F,29/F-49/F
T1CWA-3	2	35	70	8/F-26/F,29/F-49/F
T1CWA-2	14	35	490	8/F-26/F,29/F-49/F
T1CWA-1	8	35	280	8/F-26/F,29/F-49/F
T1CWB-3	4	35	140	8/F-26/F,29/F-49/F
T1CWB-2	10	35	350	8/F-26/F,29/F-49/F
T1CWB-1	2	35	70	8/F-26/F,29/F-49/F
T1CWC-1	12	35	420	8/F-26/F,29/F-49/F
T1CWM-2	2	35	70	8/F-26/F,29/F-49/F
T1CWM-1	6	35	210	8/F-26/F,29/F-49/F
T1CWL-2	6	35	210	8/F-26/F,29/F-49/F
T1CWL-1	2	35	70	8/F-26/F,29/F-49/F
T1CWK-2	2	35	70	8/F-26/F,29/F-49/F
T1CWK-1	6	35	210	8/F-26/F,29/F-49/F
T1CWJ-2	6	35	210	8/F-26/F,29/F-49/F
T1CWJ-1	2	35	70	8/F-26/F,29/F-49/F
T1CWH-2	12	35	420	8/F-26/F,29/F-49/F
T2CWH-1	14	35	490	8/F-26/F,29/F-49/F
T2CWG-2	8	35	280	8/F-26/F,29/F-49/F
T2CWF-2	2	35	70	8/F-26/F,29/F-49/F
T2CWF-1	6	35	210	8/F-26/F,29/F-49/F
T2CWE-2	6	35	210	8/F-26/F,29/F-49/F
T2CWE-1	2	35	70	8/F-26/F,29/F-49/F
T2CWD-1	2	35	70	8/F-26/F,29/F-49/F
T2CWC-2	6	35	210	8/F-26/F,29/F-49/F
T2CWC-1	2	35	70	8/F-26/F,29/F-49/F
T2CWB-2	12	35	420	8/F-26/F,29/F-49/F
T2CWB-1	4	35	140	8/F-26/F,29/F-49/F
T2CWA-2	4	35	140	8/F-26/F,29/F-49/F
T2CWA-1	12	35	420	8/F-26/F,29/F-49/F
T2CWN-2	6	35	210	8/F-26/F,29/F-49/F
T2CWN-1	2	35	70	8/F-26/F,29/F-49/F
T2CWM-3	6	35	210	8/F-26/F,29/F-49/F
T2CWM-2	10	35	350	8/F-26/F,29/F-49/F
T2CWM-1	2	35	70	8/F-26/F,29/F-49/F
T2CWL-2	4	35	140	8/F-26/F,29/F-49/F
T2CWL-1	2	35	70	8/F-26/F,29/F-49/F
T2CWK-2	2	35	70	8/F-26/F,29/F-49/F
T2CWK-1	4	35	140	8/F-26/F,29/F-49/F
T2CWJ-1	6	35	210	8/F-26/F,29/F-49/F
T2CWH-2	4	35	140	8/F-26/F,29/F-49/F
T3CWF-1	8	35	280	8/F-26/F,29/F-49/F

使用位置	數量	層數	總數	樓層
T3CWF-1	6	35	210	8/F-26/F,29/F-49/F
T3CWE-1	12	35	420	8/F-26/F,29/F-49/F
T3CWM-2	2	35	70	8/F-26/F,29/F-49/F
T3CWM-1	6	35	210	8/F-26/F,29/F-49/F
T3CWL-2	6	35	210	8/F-26/F,29/F-49/F
T3CWL-1	2	35	70	8/F-26/F,29/F-49/F
T3CWK-2	2	35	70	8/F-26/F,29/F-49/F
T3CWK-1	6	35	210	8/F-26/F,29/F-49/F
T3CWJ-2	2	35	70	8/F-26/F,29/F-49/F
T3CWJ-1	6	35	210	8/F-26/F,29/F-49/F
T3CWH-3	2	35	70	8/F-26/F,29/F-49/F
T3CWH-2	2	35	70	8/F-26/F,29/F-49/F
T3CWH-1	6	35	210	8/F-26/F,29/F-49/F
T3CWC-2	6	35	210	8/F-26/F,29/F-49/F
T3CWC-1	2	35	70	8/F-26/F,29/F-49/F
T3CWB-2	12	35	420	8/F-26/F,29/F-49/F
T3CWB-1	4	35	140	8/F-26/F,29/F-49/F
T3CWA-2	4	35	140	8/F-26/F,29/F-49/F
T3CWA-1	12	35	420	8/F-26/F,29/F-49/F
T3CWD-1	4	35	140	8/F-26/F,29/F-49/F
T3CWG-1	4	35	140	8/F-26/F,29/F-49/F
T3CWF-2	6	35	210	8/F-26/F,29/F-49/F
T5CWA-2	4	35	140	8/F-26/F,29/F-49/F
T5CWA-1	2	35	70	8/F-26/F,29/F-49/F
T5CWN-1	10	35	350	8/F-26/F,29/F-49/F
T5CWN-1	2	35	70	8/F-26/F,29/F-49/F
T5CWM-2	2	35	70	8/F-26/F,29/F-49/F
T5CWM-1	10	35	350	8/F-26/F,29/F-49/F
T5CWM-1	4	35	140	8/F-26/F,29/F-49/F
T5CWL-2	4	35	140	8/F-26/F,29/F-49/F
T5CWL-1	10	35	350	8/F-26/F,29/F-49/F
T5CWL-1	2	35	70	8/F-26/F,29/F-49/F
T5CWJ-1	10	35	350	8/F-26/F,29/F-49/F
T5CWH-3	4	35	140	8/F-26/F,29/F-49/F
T5CWH-2	10	35	350	8/F-26/F,29/F-49/F
T5CWH-1	2	35	70	8/F-26/F,29/F-49/F
T5CWG-2	2	35	70	8/F-26/F,29/F-49/F
T5CWG-1	6	35	210	8/F-26/F,29/F-49/F
T5CWF-2	6	35	210	8/F-26/F,29/F-49/F
T5CWF-1	2	35	70	8/F-26/F,29/F-49/F
T5CWE-2	2	35	70	8/F-26/F,29/F-49/F
T5CWE-1	6	35	210	8/F-26/F,29/F-49/F
T5CWD-2	6	35	210	8/F-26/F,29/F-49/F
T5CWD-1	2	35	70	8/F-26/F,29/F-49/F
T5CWC-1	8	35	280	8/F-26/F,29/F-49/F
T5CWC-1	4	23	92	22/F-26/F,29/F-49/F
T5CWA-3	14	35	490	8/F-26/F,29/F-49/F
合計:	18432			

加工圖參見:837-AG01

工程號	J-837	地盤	觀塘裕民坊
名稱	固定鋁碼加工圖(數據表)		採用
材料	-	地盤	
顏色	-	工廠	

附件

P.18

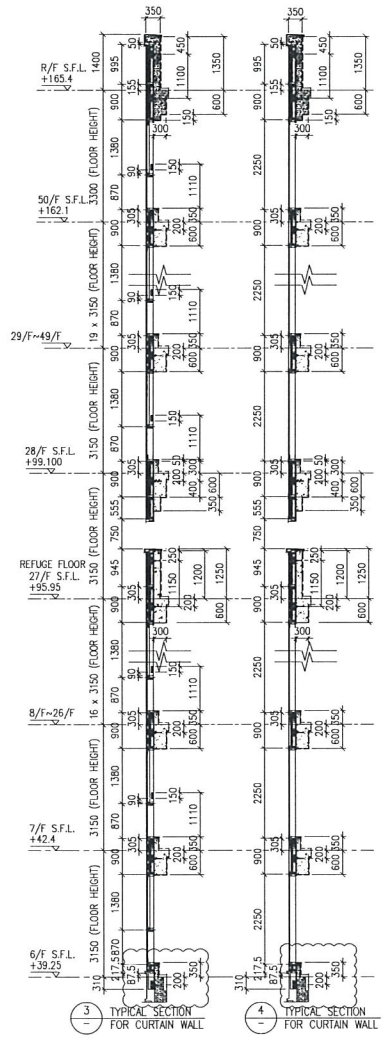
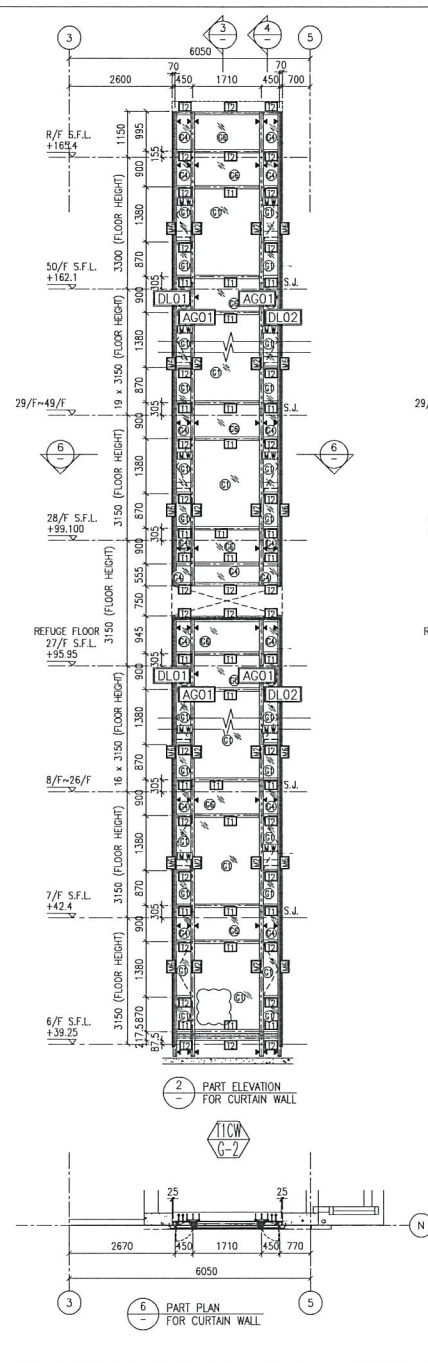
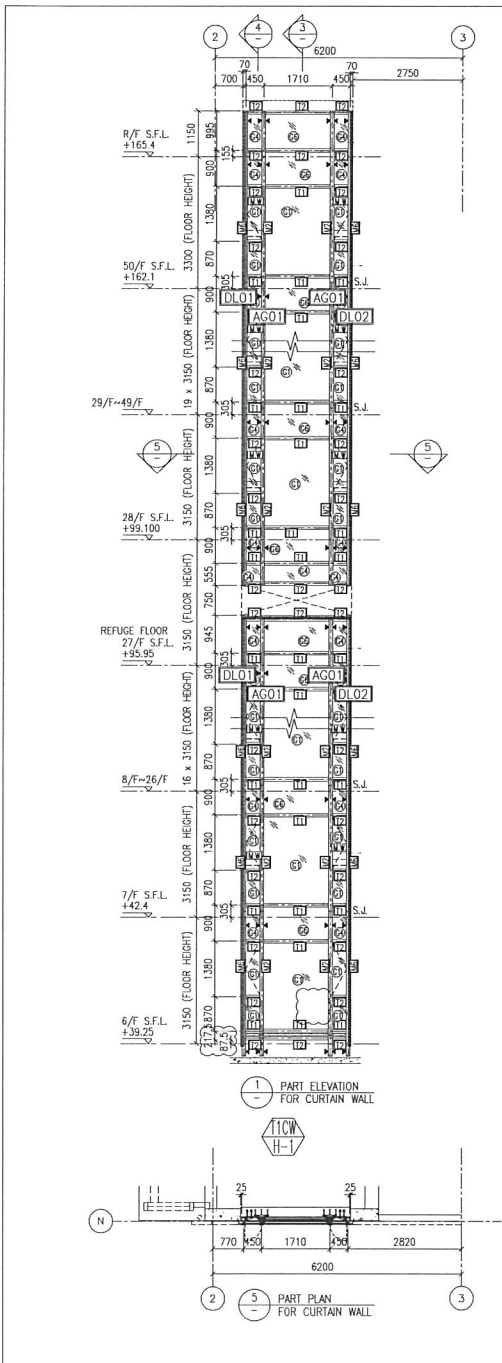

- LEGEND:**
- 10 mm THK. TEMPERED BLUE GLASS (OUTER) + 9 mm AIR SPACE + 10 mm THK. TEMPERED GLASS (INNER)
 - 6 mm THK. TEMPERED BLUE GLASS (OUTER) + 3 mm AIR SPACE + 6 mm THK. TEMPERED GLASS (INNER)
 - 10 mm THK. TEMPERED BLUE TINTED GLASS
 - 8 mm THK. HEAT STRENGTHENED BLUE TINTED GLASS (SPANDREL GLASS)
 - 8 mm THK. TEMPERED BLUE TINTED GLASS (SPANDREL GLASS)
 - 10 mm THK. TEMPERED GLASS (INTERNAL PROTECTIVE BARRIER)
 - 3 mm THK. ALUM. CLADDING
 - MAINTENANCE WINDOW
 - STACK JOINT
 - ALUM. EXTRUSION DIE NO.
 - SUPPORT POINT

B.D. REF :	
CLIENT : 信和置業有限公司 Sino Land Company Limited	
ARCHITECT : WONG TUNG & PARTNERS LIMITED ARCHITECTS & PLANNERS	
MAIN CONTRACTOR : CR Construction Company Limited	
STRUCTURAL ENGINEER : AECOM	
FACADE CONSULTANT: AECOM	
NOTE: 1. ALL DIMENSIONS ARE IN mm. 2. ALL ELEVATIONS ARE VIEWED FROM OUTSIDE. 3. ALL DIMENSIONS TO BE VERIFIED ON SITE BEFORE FABRICATION.	
LEGEND: - DETAIL MARK NO. - REFER SHEET NO.	
1. F.F.L. -- FINISHED FLOOR LEVEL 2. S.F.L. -- STRUCTURAL FLOOR LEVEL 3. (R) -- REVERSED DETAIL	
A	10/9/2018 GENERAL REVISED
REV	DWR
JOB NO. : J-837	
PROJECT : URA KWUN TONG TOWN CENTRE REDEVELOPMENT (AREA 2 & 3) AT NKIL 6514, KWUN TONG, KWLOON	
TITLE : PART ELEVATION OF CURTAIN WALL AT TOWER 1	
DATE : 04-JUL-18	SCALE : 1:60 (A1)
DRAWN BY : ASING	CHECKED BY : -
 MIDI ALUMINUM FABRICATOR LTD. Units 6-8, Sunny Industrial Centre, 1/F #10 Che Kwo Ling Road, Kwloon Tel:23489211-4 Fax:(852)27272666	
DWG NO. : JB37-CW-2101	REV. : A

P.19

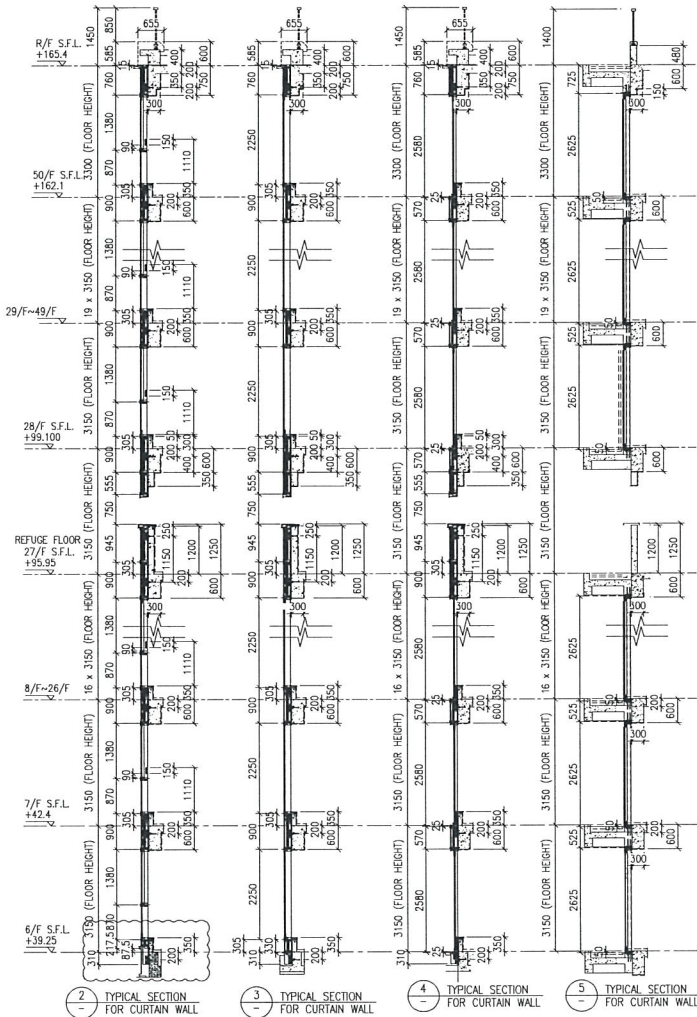
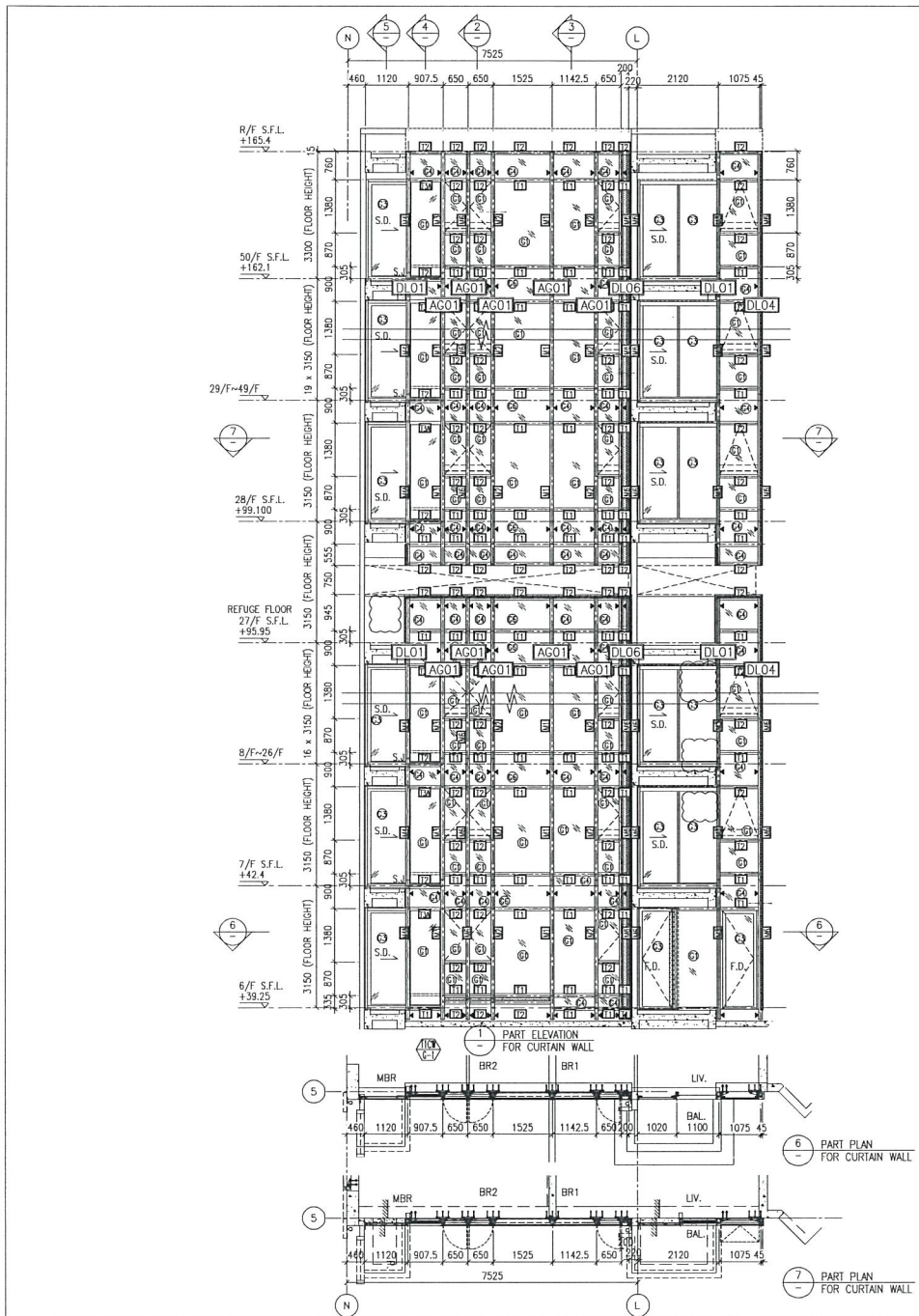

- LEGEND:**
- 10 mm THK. TEMPERED BLUE GLASS (OUTER) + 9 mm AIR SPACE + 10 mm THK. TEMPERED GLASS (INNER)
 - 6 mm THK. TEMPERED BLUE GLASS (OUTER) + 9 mm AIR SPACE + 6 mm THK. TEMPERED GLASS (INNER)
 - 10 mm THK. TEMPERED BLUE TINTED GLASS
 - 8 mm THK. HEAT STRENGTHENED BLUE TINTED GLASS (SPANDREL GLASS)
 - 8 mm THK. TEMPERED BLUE TINTED GLASS (SPANDREL GLASS)
 - 10 mm THK. TEMPERED GLASS (INTERNAL PROTECTIVE BARRIER)
 - 3 mm THK. ALUM. CLADDING
 - M.W. - MAINTENANCE WINDOW
 - S.J. - STACK JOINT
 - A.C.D.N. - ALUM. EXTRUSION DIE NO.
 - SUPPORT POINT

B.D. REF :

CLIENT :
 Sino Land Company Limited

ARCHITECT :
 WONG TUNG & PARTNERS LIMITED ARCHITECTS & PLANNERS

MAIN CONTRACTOR :
 CR Construction Company Limited

STRUCTURAL ENGINEER :
 ACOM

FACADE CONSULTANT :
 ACOM

NOTE :
 1. ALL DIMENSIONS ARE IN mm.
 2. ALL ELEVATIONS ARE VIEWED FROM OUTSIDE.
 3. ALL DIMENSIONS TO BE VERIFIED ON SITE BEFORE FABRICATION.

LEGEND :
 - DETAIL MARK NO.
 - REFER SHEET NO.

1. F.F.L. - FINISHED FLOOR LEVEL
 2. S.F.L. - STRUCTURAL FLOOR LEVEL
 3. (R) - REVERSED DETAIL

B	12/10/2018	GENERAL REVISED
A	10/9/2018	GENERAL REVISED
REV	DATE	REASON

JOB NO. : J-837

PROJECT :
 URA KWUN TONG TOWN CENTRE REDEVELOPMENT (AREA 2 & 3) AT NKIL 6514, KWUN TONG, KWLOON

TITLE :
 PART ELEVATION OF CURTAIN WALL OF TOWER 1

DATE : 04-JUL-18 SCALE : 1:60 (A1)

DRAWN BY : ASING CHECKED BY : -

美特鋁質有限公司
 M.T.I. ALUMINIUM FABRICATOR LTD.
 Units 5-8, Sunray Industrial Centre, 1/F
 610 Cha Kwo Ling Road, Kowloon
 Tel:23489211-4 Fax:(852)2727666

DWG NO. : JB37-CW-2102 REV. : B

P.20

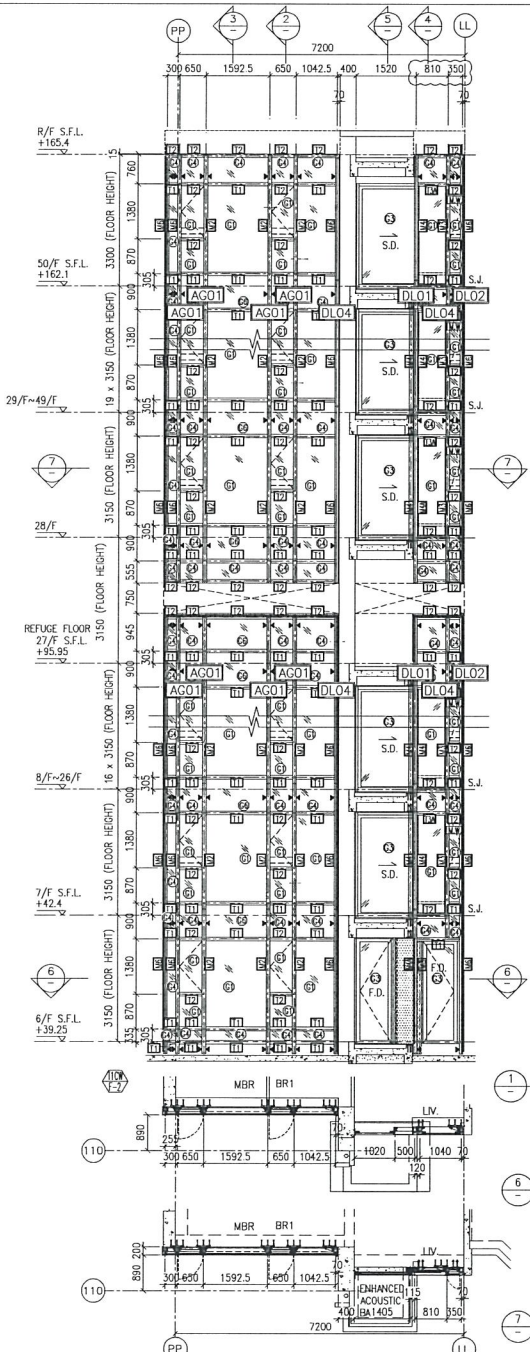

1 PART ELEVATION FOR CURTAIN WALL
 2 TYPICAL SECTION FOR CURTAIN WALL
 3 TYPICAL SECTION FOR CURTAIN WALL
 4 TYPICAL SECTION FOR CURTAIN WALL
 5 TYPICAL SECTION FOR CURTAIN WALL
 6 PART PLAN FOR CURTAIN WALL
 7 PART PLAN FOR CURTAIN WALL

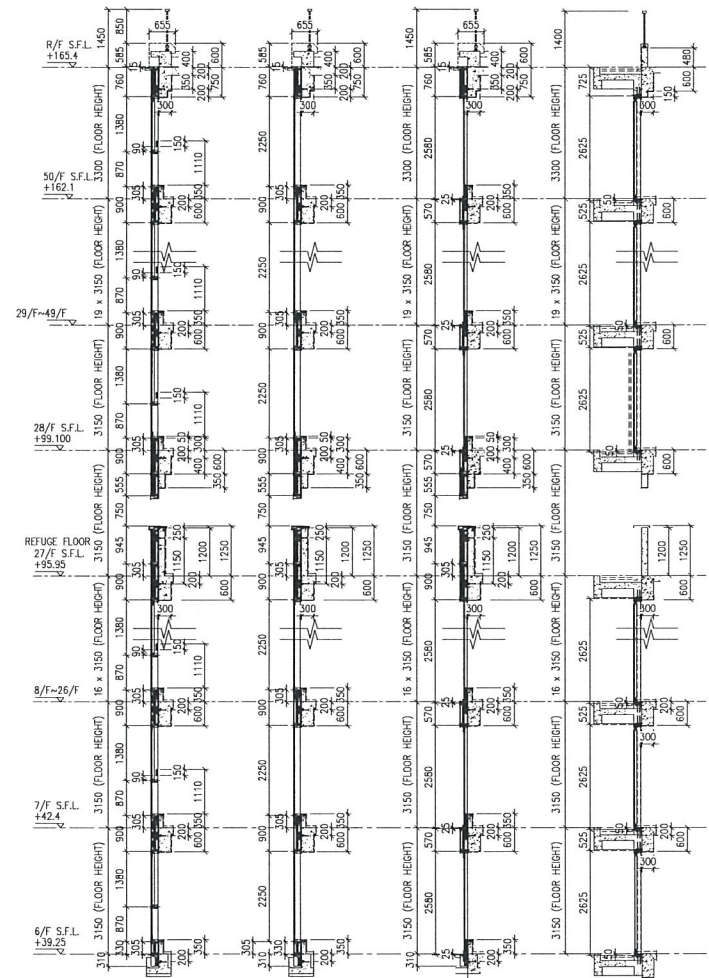

1 PART ELEVATION FOR CURTAIN WALL
 2 TYPICAL SECTION FOR CURTAIN WALL
 3 TYPICAL SECTION FOR CURTAIN WALL
 4 TYPICAL SECTION FOR CURTAIN WALL
 5 TYPICAL SECTION FOR CURTAIN WALL

- LEGEND:
- 10 mm THK. TEMPERED BLUE GLASS (OUTER) + 9 mm THK. TEMPERED BLUE GLASS (INNER) + 9 mm AIR SPACE + 10 mm THK. TEMPERED GLASS (INNER)
 - 6 mm THK. TEMPERED BLUE GLASS (OUTER) + 9 mm AIR SPACE + 6 mm THK. TEMPERED GLASS (INNER)
 - 10 mm THK. TEMPERED BLUE TINTED GLASS
 - 8 mm THK. HEAT STRENGTHENED BLUE TINTED GLASS (SPANDREL GLASS)
 - 8 mm THK. TEMPERED BLUE TINTED GLASS (SPANDREL GLASS)
 - 10 mm THK. TEMPERED GLASS (INTERNAL PROTECTIVE BARRIER)
 - 3 mm THK. ALUM. CLADDING
 - M.W. - MAINTENANCE WINDOW
 - S.J. - STACK JOINT
 - A.C.O. - ALUM. EXTRUSION DIE NO.
 - ▲ - SUPPORT POINT

B.D. REF :	
CLIENT : 信和置業有限公司 Sino Land Company Limited	
ARCHITECT : WONG TUNG & PARTNERS LIMITED ARCHITECTS & PLANNERS	
MAIN CONTRACTOR : CR Construction Company Limited	
STRUCTURAL ENGINEER : ACOM	
FACADE CONSULTANT : ACOM	
NOTE : 1. ALL DIMENSIONS ARE IN mm. 2. ALL ELEVATIONS ARE VIEWED FROM OUTSIDE. 3. ALL DIMENSIONS TO BE VERIFIED ON SITE BEFORE FABRICATION.	
LEGEND : X1 - DETAIL MARK NO. X001 - REFER SHEET NO. 1. F.F.L. -- FINISHED FLOOR LEVEL 2. S.F.L. -- STRUCTURAL FLOOR LEVEL 3. (P) -- REVERSED DETAIL	
B	12/10/2018 GENERAL REVISED
A	10/9/2018 GENERAL REVISED
NO.	DATE REVISION BY
JOB NO. : J-837	
PROJECT : URA KWUN TONG TOWN CENTRE REDEVELOPMENT (AREA 2 & 3) AT NKIL 6514, KWUN TONG, KWLOON	
TITLE : PART ELEVATION OF CURTAIN WALL AT TOWER 1	
DATE : 04-JUL-18	SCALE : 1:60 (A1)
DRAWN BY : ASING	CHECKED BY : -
 MIDI ALUMINIUM FABRICATOR LTD. Units 6-8, Sunny Industrial Centre, 1/F 610 Che Kwo Ling Road, Kwokson Tel:23489211-4 Fax:(852)2727666	
DWG NO. : JB37-CW-2103	REV. : B

P.21

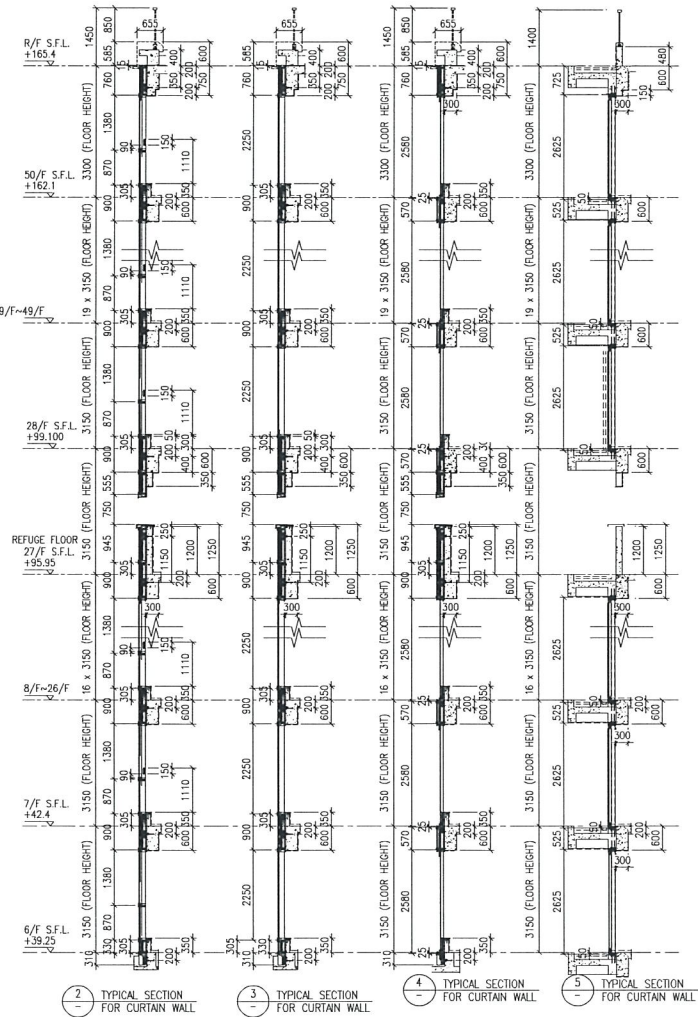
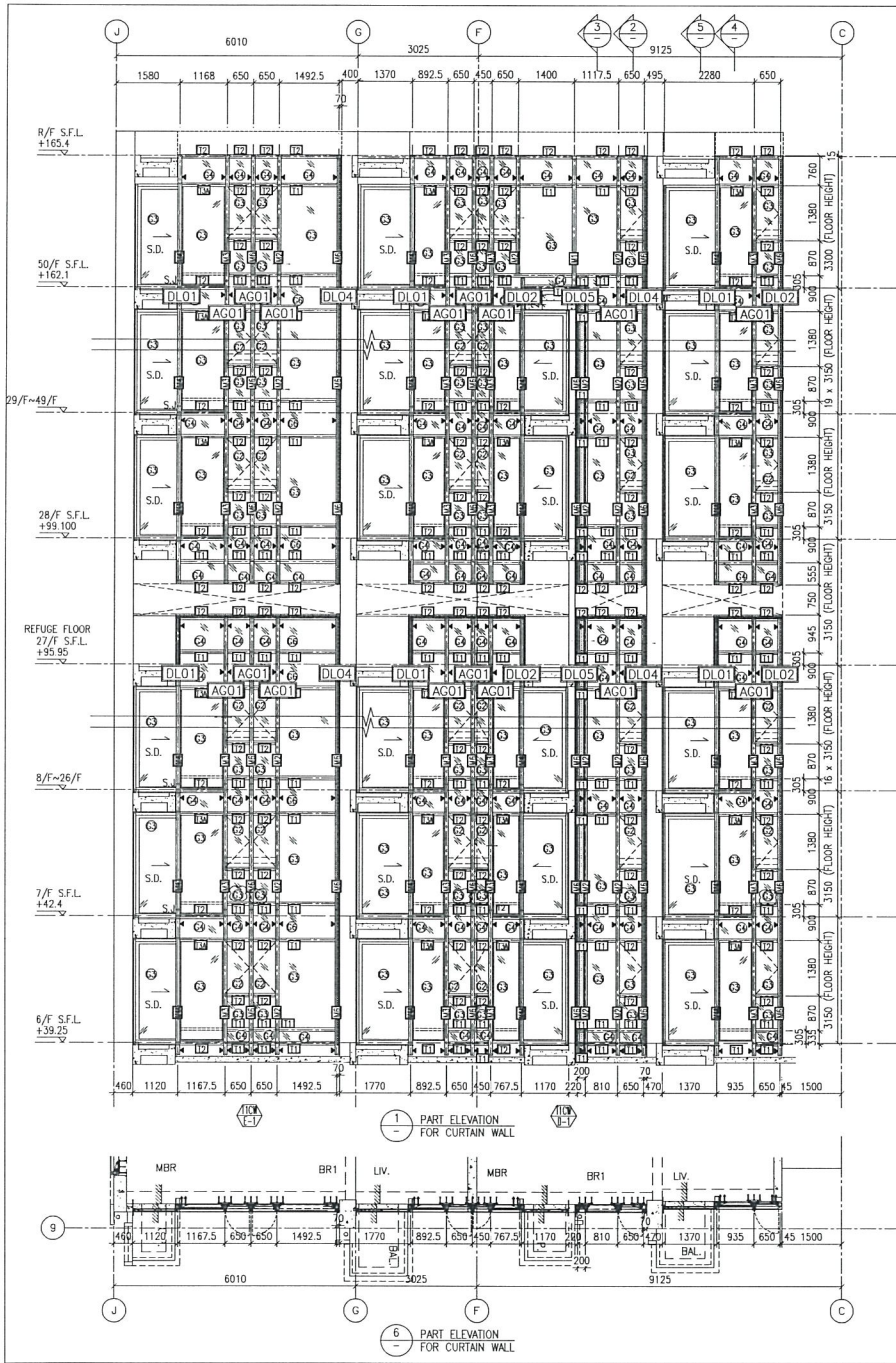

- LEGEND:**
- 10 mm THK. TEMPERED BLUE GLASS (OUTER) + 9 mm AIR SPACE + 10 mm THK. TEMPERED GLASS (INNER)
 - 6 mm THK. TEMPERED BLUE GLASS (OUTER) + 9 mm AIR SPACE + 6 mm THK. TEMPERED GLASS (INNER)
 - 10 mm THK. TEMPERED BLUE TINTED GLASS
 - 8 mm THK. HEAT STRENGTHENED BLUE TINTED GLASS (SPANDELR GLASS)
 - 8 mm THK. TEMPERED BLUE TINTED GLASS (SPANDELR GLASS)
 - 10 mm THK. TEMPERED GLASS (INTERNAL PROTECTIVE BARRIER)
 - 3 mm THK. ALUM. CLADDING
 - M.W. - MAINTENANCE WINDOW
 - S.J. - STACK JOINT
 - AE01 - ALUM. EXTRUSION DIE NO.
 - ▲ - SUPPORT POINT

B.D. REF :

CLIENT :
 Sino Land Company Limited

ARCHITECT :
 WONG TUNG & PARTNERS LIMITED ARCHITECTS & PLANNERS

MAIN CONTRACTOR :
 CR Construction Company Limited

STRUCTURAL ENGINEER :
 ACOM

FAÇADE CONSULTANT :
 ACOM

NOTE :

- ALL DIMENSIONS ARE IN mm.
- ALL ELEVATIONS ARE VIEWED FROM OUTSIDE.
- ALL DIMENSIONS TO BE VERIFIED ON SITE BEFORE FABRICATION.

LEGEND :

- X1 - DETAIL MARK NO.
- X001 - REFER SHEET NO.
- 1. F.F.L. -- FINISHED FLOOR LEVEL
- 2. S.F.L. -- STRUCTURAL FLOOR LEVEL
- 3. (R) -- REVERSED DETAIL

B	12/10/2018	GENERAL REVISED	
A	10/9/2018	GENERAL REVISED	
NO.	DATE	REVISED	BY

JOB NO. : J-837

PROJECT : URA KWUN TONG TOWN CENTRE REDEVELOPMENT (AREA 2 & 3) AT NKIL 6514, KWUN TONG, KWLOON

TITLE : PART ELEVATION OF CURTAIN WALL AT TOWER 1

DATE : 04-JUL-18	SCALE : 1:60 (A1)
DRAWN BY : ASING	CHECKED BY : -

MIDI ALUMINUM FABRICATOR LTD.
 Units 6-8, Sunny Industrial Centre, 1/F
 610 Che Kwo Ling Road, Kowloon
 Tel: 23489211-4 Fax: (852) 27272666

DWG NO. : JB37-CW-2105 REV. : B

P-23

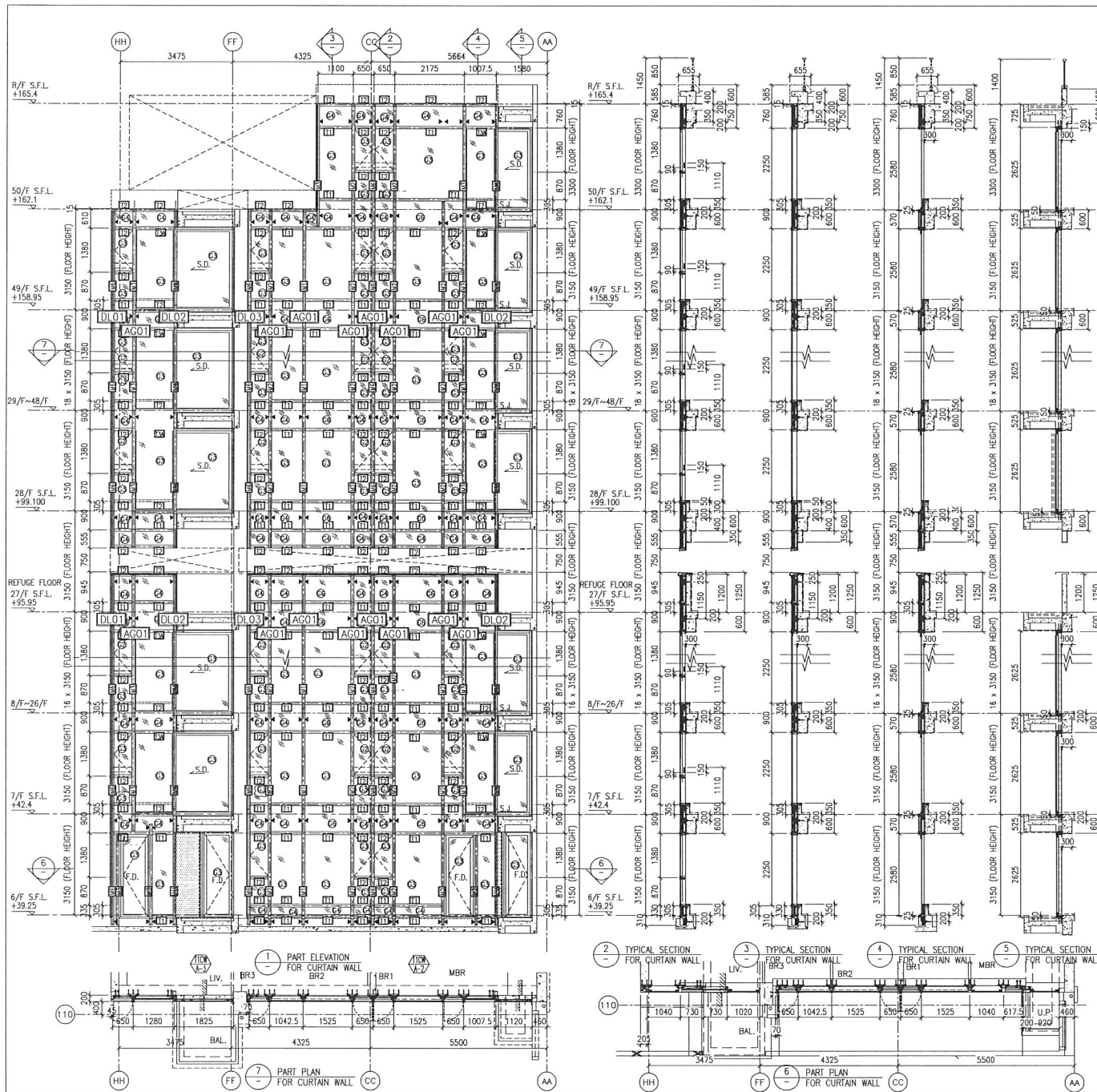

- LEGEND:**
- 10 mm THK. TEMPERED BLUE GLASS (OUTER) + 9 mm AIR SPACE + 10 mm THK. TEMPERED GLASS (INNER)
 - 6 mm THK. TEMPERED BLUE GLASS (OUTER) + 9 mm AIR SPACE + 6 mm THK. TEMPERED GLASS (INNER)
 - 10 mm THK. TEMPERED BLUE TINTED GLASS
 - 8 mm THK. HEAT STRENGTHENED BLUE TINTED GLASS (SPANDREL GLASS)
 - 8 mm THK. TEMPERED BLUE TINTED GLASS (SPANDREL GLASS)
 - 10 mm THK. TEMPERED GLASS (INTERNAL PROTECTIVE BARRIER)
 - 3 mm THK. ALUM. CLADDING
 - MAINTENANCE WINDOW
 - STACK JOINT
 - ALUM. EXTRUSION DIE NO.
 - SUPPORT POINT

B.D. REF :

CLIENT : Sino Land Company Limited

ARCHITECT : WONG TUNG & PARTNERS LIMITED ARCHITECTS & PLANNERS

MAIN CONTRACTOR : CR Construction Company Limited

STRUCTURAL ENGINEER : ACOM

FAÇADE CONSULTANT : ACOM

NOTE :

1. ALL DIMENSIONS ARE IN mm.
2. ALL ELEVATIONS ARE VIEWED FROM OUTSIDE.
3. ALL DIMENSIONS TO BE VERIFIED ON SITE BEFORE FABRICATION.

LEGEND :

- DETAIL MARK NO.
- REFER SHEET NO.
- 1. F.F.L. --- FINISHED FLOOR LEVEL
- 2. S.F.L. --- STRUCTURAL FLOOR LEVEL
- 3. --- REVERSED DETAIL

B	12/10/2018	GENERAL REVISED	
A	10/9/2018	GENERAL REVISED	
NO.	DATE	REVISED	BY

JOB NO. : J-837

PROJECT : URA KWUN TONG TOWN CENTRE REDEVELOPMENT (AREA 2 & 3) AT NKIL 6514, KWUN TONG, KWLOON

TITLE : PART ELEVATION OF CURTAIN WALL AT TOWER 1

DATE : 04-JUL-18 SCALE : 1:60 (A1)

DRAWN BY : ASING CHECKED BY : -

MIDI ALUMINUM FABRICATOR LTD.
Units 6-8, Sunway Industrial Centre, 1/F
810 Che Kwo Ling Road, Kwailoon
Tel: 23489211-4 Fax: (852) 2727666

DWG NO. : JB37-CW-2106 REV. : B

P.24

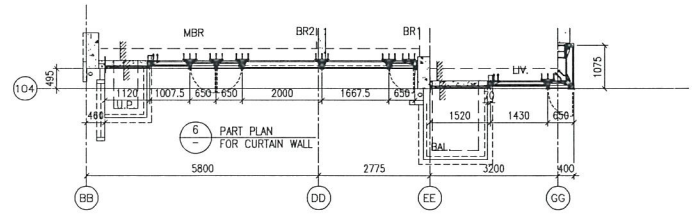
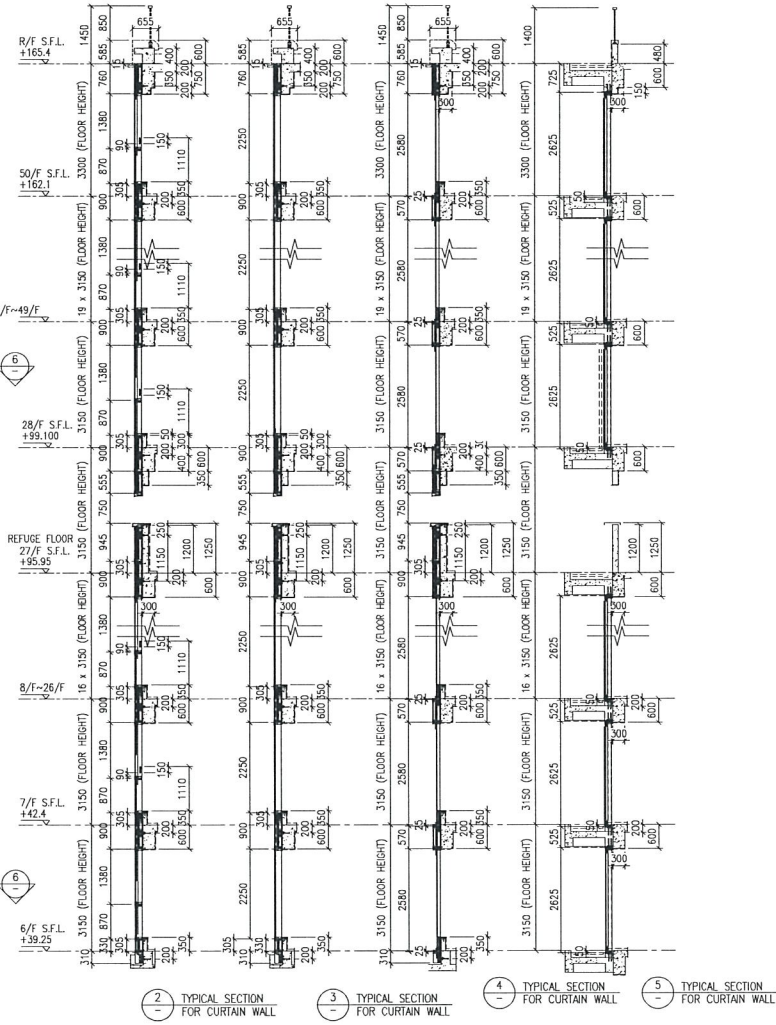
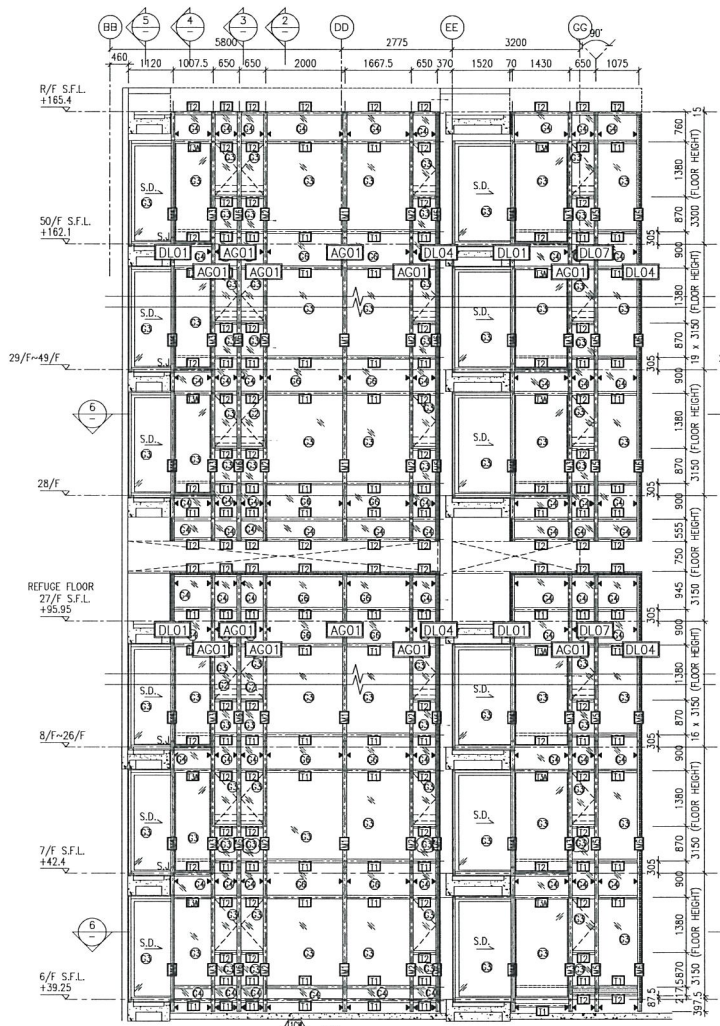

- LEGEND:**
- 10 mm THK. TEMPERED BLUE GLASS (OUTER) + 9 mm AIR SPACE + 10 mm THK. TEMPERED GLASS (INNER)
 - 6 mm THK. TEMPERED BLUE GLASS (OUTER) + 9 mm AIR SPACE + 6 mm THK. TEMPERED GLASS (INNER)
 - 10 mm THK. TEMPERED BLUE TINTED GLASS
 - 8 mm THK. HEAT STRENGTHENED BLUE TINTED GLASS (SPANDREL GLASS)
 - 8 mm THK. TEMPERED BLUE TINTED GLASS (SPANDREL GLASS)
 - 10 mm THK. TEMPERED GLASS (INTERNAL PROTECTIVE BARRIER)
 - 3 mm THK. ALUM. CLADDING
 - M.W. - MAINTENANCE WINDOW
 - S.J. - STACK JOINT
 - AZO1 - ALUM. EXTRUSION DIE NO.
 - SUPPORT POINT

B.D. REF :

CLIENT :
 Sino Land Company Limited

ARCHITECT :
 WONG TUNG & PARTNERS LIMITED ARCHITECTS & PLANNERS

MAIN CONTRACTOR :
 CR Construction Company Limited

STRUCTURAL ENGINEER :
 ACOM

FACADE CONSULTANT :
 ACOM

NOTE :

- ALL DIMENSIONS ARE IN mm.
- ALL ELEVATIONS ARE VIEWED FROM OUTSIDE.
- ALL DIMENSIONS TO BE VERIFIED ON SITE BEFORE FABRICATION.

LEGEND :

- X1 - DETAIL MARK NO.
- X204 - REFER SHEET NO.
- 1. F.F.L. - FINISHED FLOOR LEVEL
- 2. S.F.L. - STRUCTURAL FLOOR LEVEL
- 3. (R) - REVERSED DETAIL

B	12/10/2018	GENERAL REWSED	
A	10/9/2018	GENERAL REWSED	
NO.	DATE	REWSED	BY

JOB NO. : J-837

PROJECT :
 URA KWUN TONG TOWN CENTRE
 REDEVELOPMENT (AREA 2 & 3) AT
 NKIL 6514, KWUN TONG, KWLOON

TITLE :
 PART ELEVATION
 OF CURTAIN WALL
 AT TOWER 1

DATE : 04-JUL-18 SCALE : 1:60 (A1)

DRAWN BY : ASING CHECKED BY : -

MIDI ALUMINUM FABRICATOR LTD.
 Units 6-8, Sunny Industrial Centre, 1/F
 610 Chee Kwo Ling Road, Kwloon
 Tel:23489211-4 Fax:(852)2727666

DWG NO. : JB37-CW-2108 REV. : B

P.26

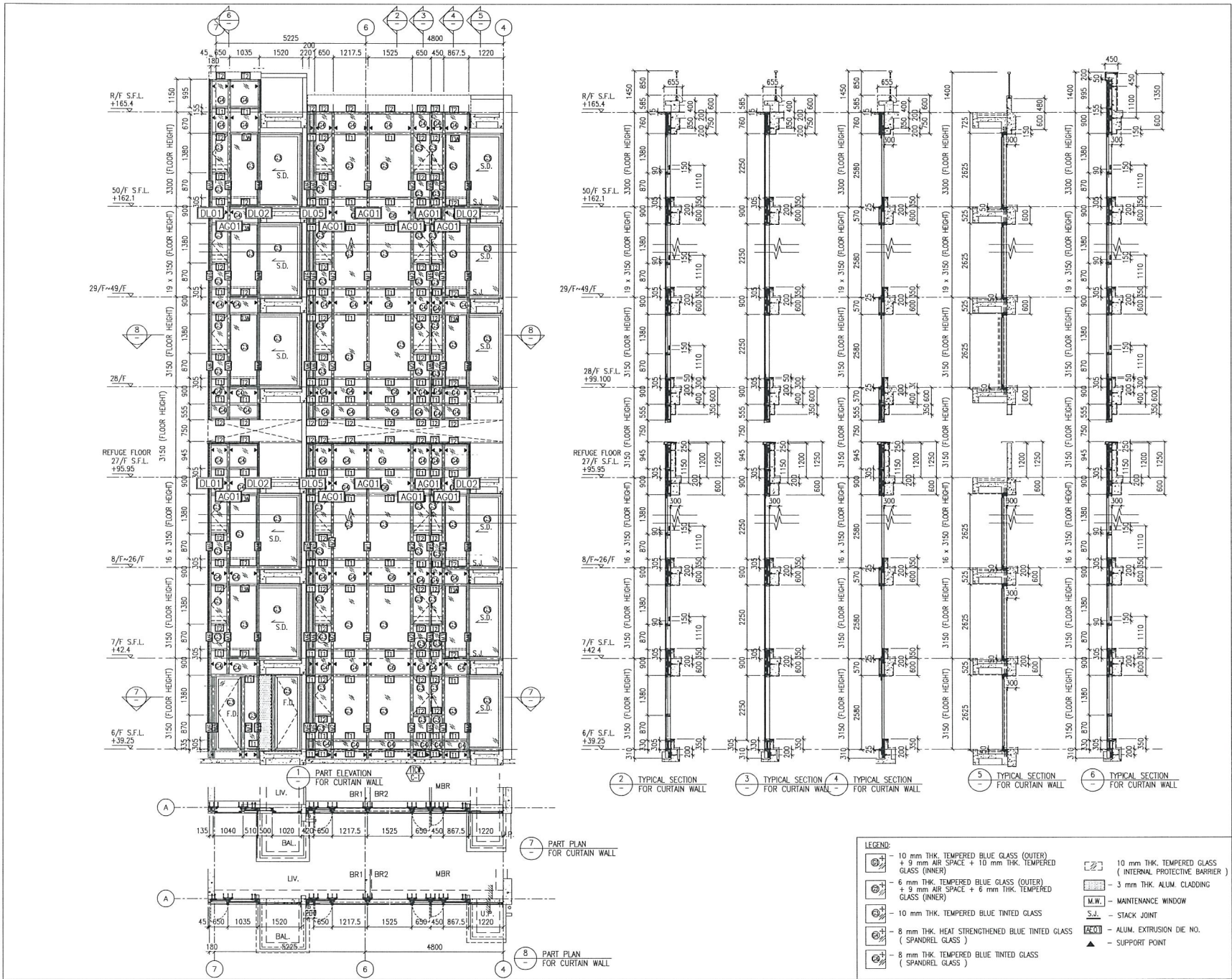

B.D. REF :

CLIENT :
 Sino Land Company Limited

ARCHITECT :
 WONG TUNG & PARTNERS LIMITED
 ARCHITECTS & PLANNERS

MAIN CONTRACTOR :
 CR Construction Company Limited

STRUCTURAL ENGINEER :
 ACOM

FACADE CONSULTANT :
 ACOM

NOTE :
 1. ALL DIMENSIONS ARE IN mm.
 2. ALL ELEVATIONS ARE VIEWED FROM OUTSIDE.
 3. ALL DIMENSIONS TO BE VERIFIED ON SITE BEFORE FABRICATION.

LEGEND :
 (X) - DETAIL MARK NO.
 (X/000) - REFER SHEET NO.

1. F.F.L. -- FINISHED FLOOR LEVEL
 2. S.F.L. -- STRUCTURAL FLOOR LEVEL
 3. (R) -- REVERSED DETAIL

B	12/10/2018	GENERAL	REVISED
A	10/9/2018	GENERAL	REVISED
MS	DATE	REVISION	BY

JOB NO. : J-837

PROJECT :
 URA KWUN TONG TOWN CENTRE
 REDEVELOPMENT (AREA 2 & 3) AT
 NKIL 6514, KWUN TONG, KWLOON

TITLE :
 PART ELEVATION OF CURTAIN WALL
 AT TOWER 1

DATE : 04-JUL-18	SCALE : 1:60 (A1)
DRAWN BY : ASING	CHECKED BY : -

美特鋁質有限公司
 MIDI ALUMINIUM FABRICATOR LTD.
 Units E-8, Sunny Industrial Centre, 1/F
 610 Che Kwo Ling Road, Kwloon
 Tel: 23489211-4 Fax: (852) 2727666

DWG NO. : J837-CW-2109 REV. : B

P-27

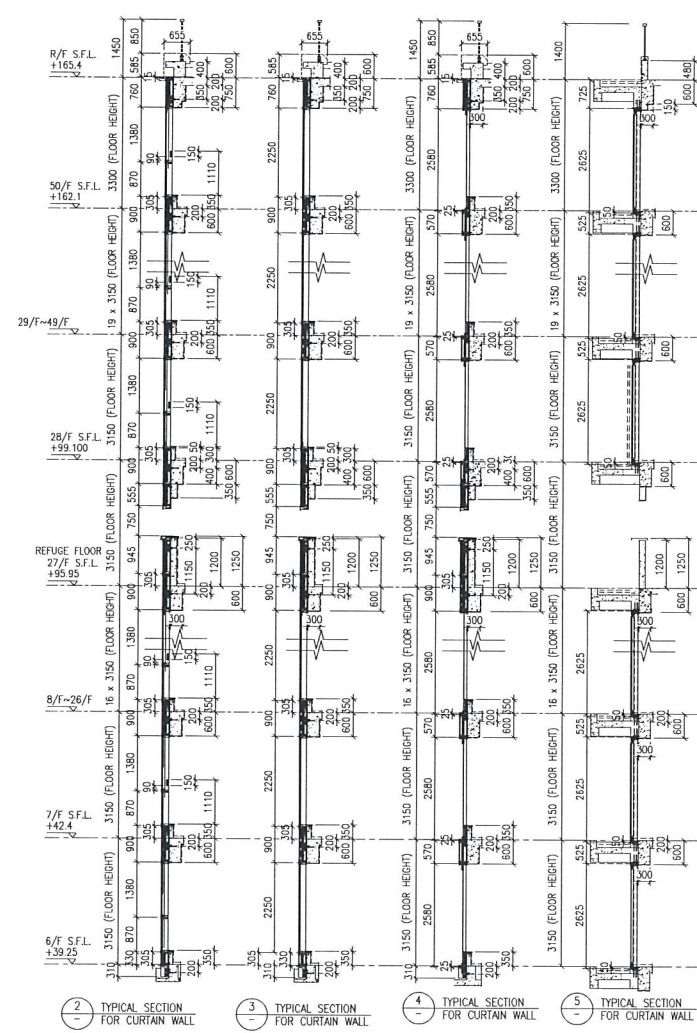
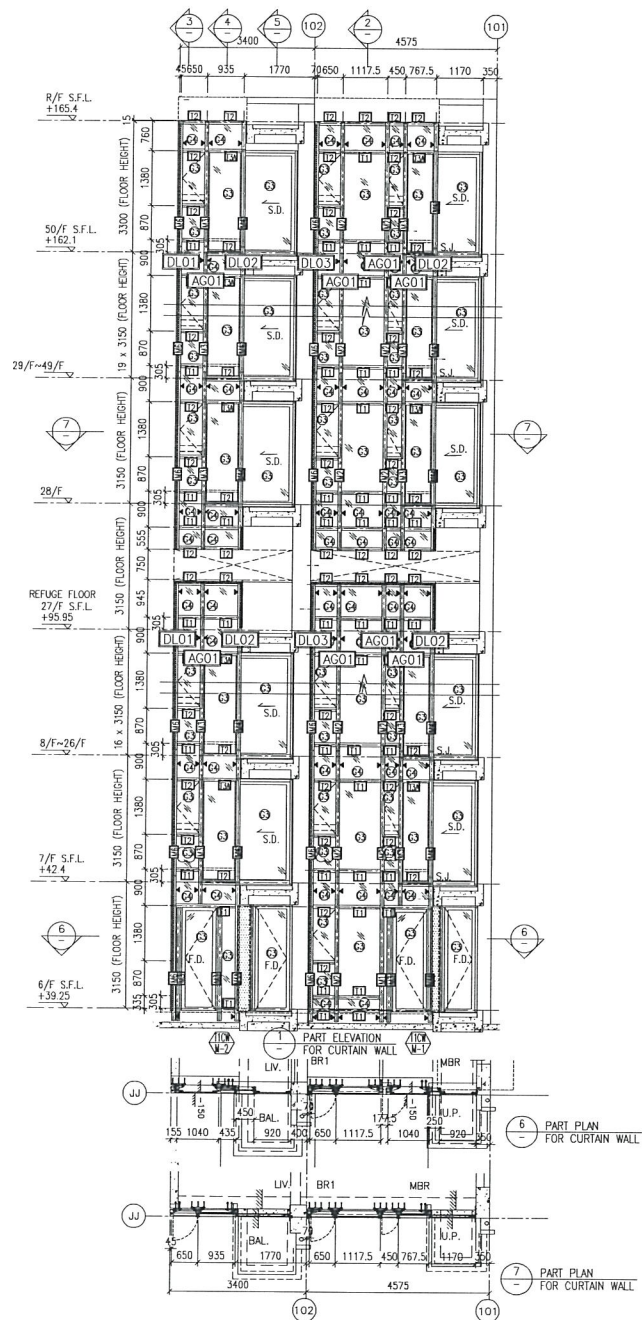

LEGEND:

	10 mm THK. TEMPERED BLUE GLASS (OUTER) + 9 mm AIR SPACE + 10 mm THK. TEMPERED GLASS (INNER)		10 mm THK. TEMPERED GLASS (INTERNAL PROTECTIVE BARRIER)
	6 mm THK. TEMPERED BLUE GLASS (OUTER) + 9 mm AIR SPACE + 6 mm THK. TEMPERED GLASS (INNER)		3 mm THK. ALUM. CLADDING
	10 mm THK. TEMPERED BLUE TINTED GLASS		M.W. - MAINTENANCE WINDOW
	8 mm THK. HEAT STRENGTHENED BLUE TINTED GLASS (SPANDELL GLASS)		S.J. - STACK JOINT
	8 mm THK. TEMPERED BLUE TINTED GLASS (SPANDELL GLASS)		AL001 - ALUM. EXTRUSION DIE NO.
	8 mm THK. TEMPERED BLUE TINTED GLASS (SPANDELL GLASS)		▲ - SUPPORT POINT

B.D. REF :

CLIENT : Sino Land Company Limited

ARCHITECT : WONG TUNG & PARTNERS LIMITED ARCHITECTS & PLANNERS

MAIN CONTRACTOR : CR Construction Company Limited

STRUCTURAL ENGINEER : AECOM

FAÇADE CONSULTANT : AECOM

NOTE :

1. ALL DIMENSIONS ARE IN mm.
2. ALL ELEVATIONS ARE VIEWED FROM OUTSIDE.
3. ALL DIMENSIONS TO BE VERIFIED ON SITE BEFORE FABRICATION.

LEGEND :

X1 - DETAIL MARK NO.
X001 - REFER SHEET NO.

1. F.F.L. -- FINISHED FLOOR LEVEL
2. S.F.L. -- STRUCTURAL FLOOR LEVEL
3. (R) -- REVERSED DETAIL

B	12/10/2018	GENERAL REVISED
A	10/9/2018	GENERAL REVISED
NO.	DATE	REVISED
		BY

JOB NO. : J-B37

PROJECT : URA KWUN TONG TOWN CENTRE REDEVELOPMENT (AREA 2 & 3) AT NKIL 6514, KWUN TONG, KWLOON

TITLE : PART ELEVATION OF CURTAIN WALL AT TOWER 1

DATE : 04--JUL--18 SCALE : 1:60 (A1)

DRAWN BY : ASING CHECKED BY : --

美特鋁質有限公司
MIDI ALUMINIUM FABRICATOR LTD.
Units 6-8, Sunny Industrial Centre, 1/F
610 Che Kwo Ling Road, Kowloon
Tel:23489211-4 Fax:(852)2727666

DWG NO. : JB37-CW-2110 REV. : B

P28

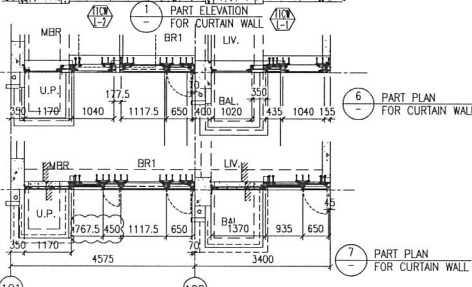
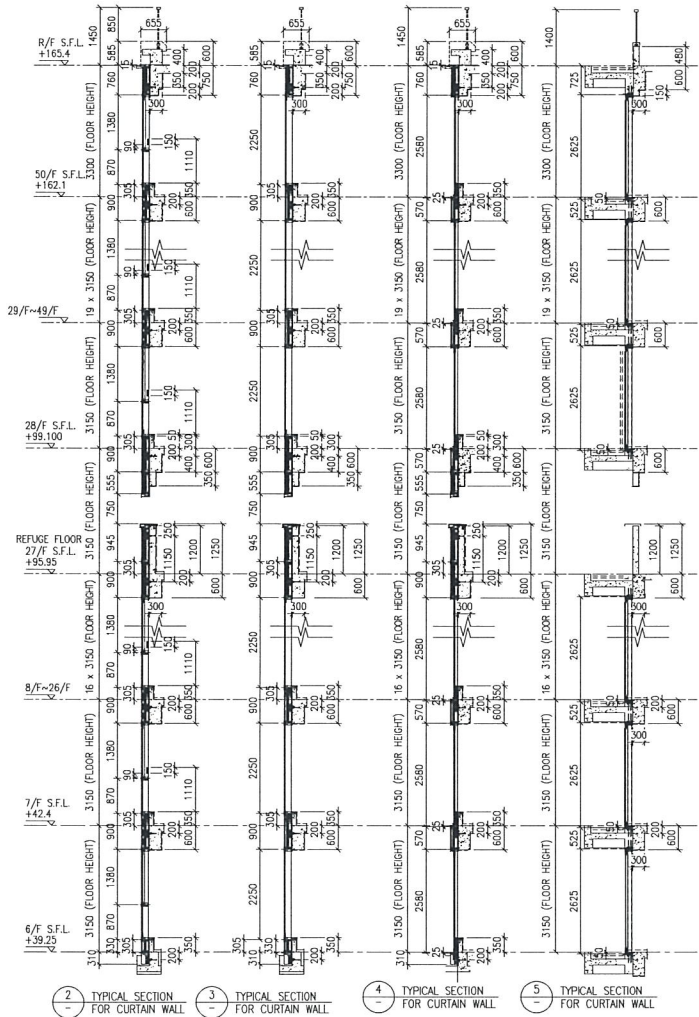
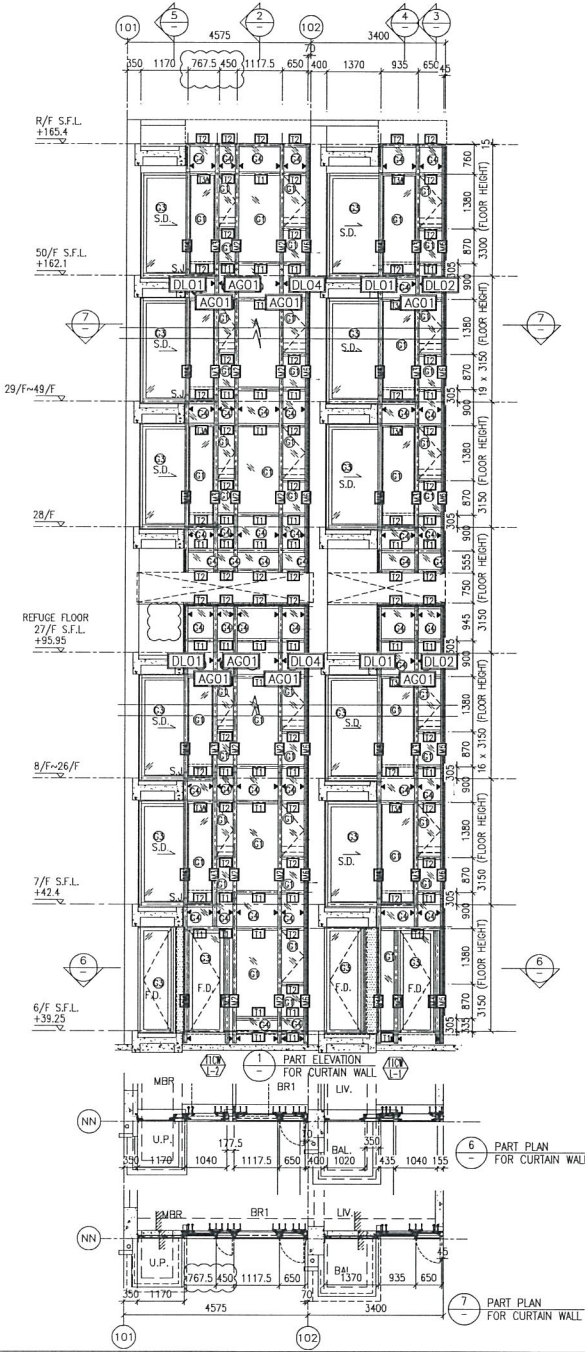

- LEGEND:
- 10 mm THK. TEMPERED BLUE GLASS (OUTER) GLASS (INNER)
 - 6 mm THK. TEMPERED BLUE GLASS (OUTER) + 9 mm AIR SPACE + 6 mm THK. TEMPERED GLASS (INNER)
 - 10 mm THK. TEMPERED BLUE TINTED GLASS
 - 8 mm THK. HEAT STRENGTHENED BLUE TINTED GLASS (SPANDREL GLASS)
 - 8 mm THK. TEMPERED BLUE TINTED GLASS (SPANDREL GLASS)
 - 10 mm THK. TEMPERED GLASS (INTERNAL PROTECTIVE BARRIER)
 - 3 mm THK. ALUM. CLADDING
 - M.W. - MAINTENANCE WINDOW
 - S.J. - STACK JOINT
 - ALUM. EXTRUSION DE NO.
 - SUPPORT POINT

B.D. REF :	
CLIENT : Sino Land Company Limited	
ARCHITECT : WONG TUNG & PARTNERS LIMITED ARCHITECTS & PLANNERS	
MAIN CONTRACTOR : CR Construction Company Limited	
STRUCTURAL ENGINEER : ACOM	
FACADE CONSULTANT : ACOM	
NOTE: 1. ALL DIMENSIONS ARE IN mm. 2. ALL ELEVATIONS ARE VIEWED FROM OUTSIDE. 3. ALL DIMENSIONS TO BE VERIFIED ON SITE BEFORE FABRICATION.	
LEGEND: DETAIL MARK NO. REFER SHEET NO.	
1. F.F.L. -- FINISHED FLOOR LEVEL 2. S.F.L. -- STRUCTURAL FLOOR LEVEL 3. (R) -- REVERSED DETAIL	
A	10/9/2018 GENERAL REVISED
REV	DATE REVISION BY
JOB NO. : J-837	
PROJECT : URA KWUN TONG TOWN CENTRE REDEVELOPMENT (AREA 2 & 3) AT NKIL 6514, KWUN TONG, KWLOON	
TITLE : PART ELEVATION OF CURTAIN WALL AT TOWER 1	
DATE : 04-JUL-18	SCALE : 1:60 (A1)
DRAWN BY : ASING	CHECKED BY : -
MIDI ALUMINUM FABRICATOR LTD. Units 6-8, Sunray Industrial Centre, 1/F 610 Che Kwo Ling Road, Kwloon Tel:23489211-4 Fax:(852)27272666	
DWG NO. : JB37-CW-2111	REV. : A

P29

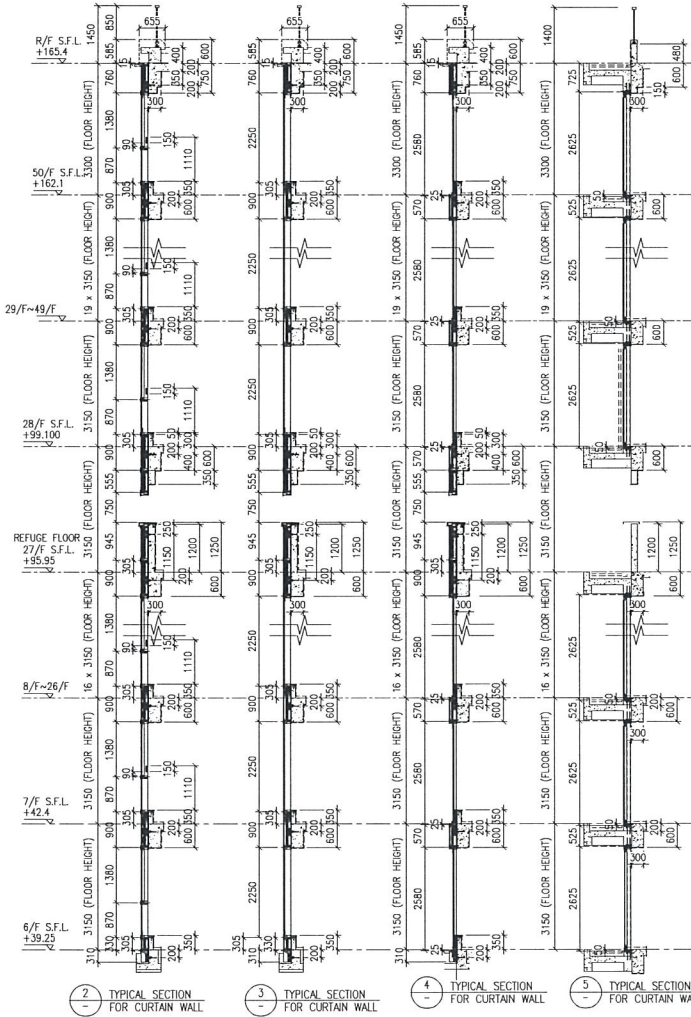
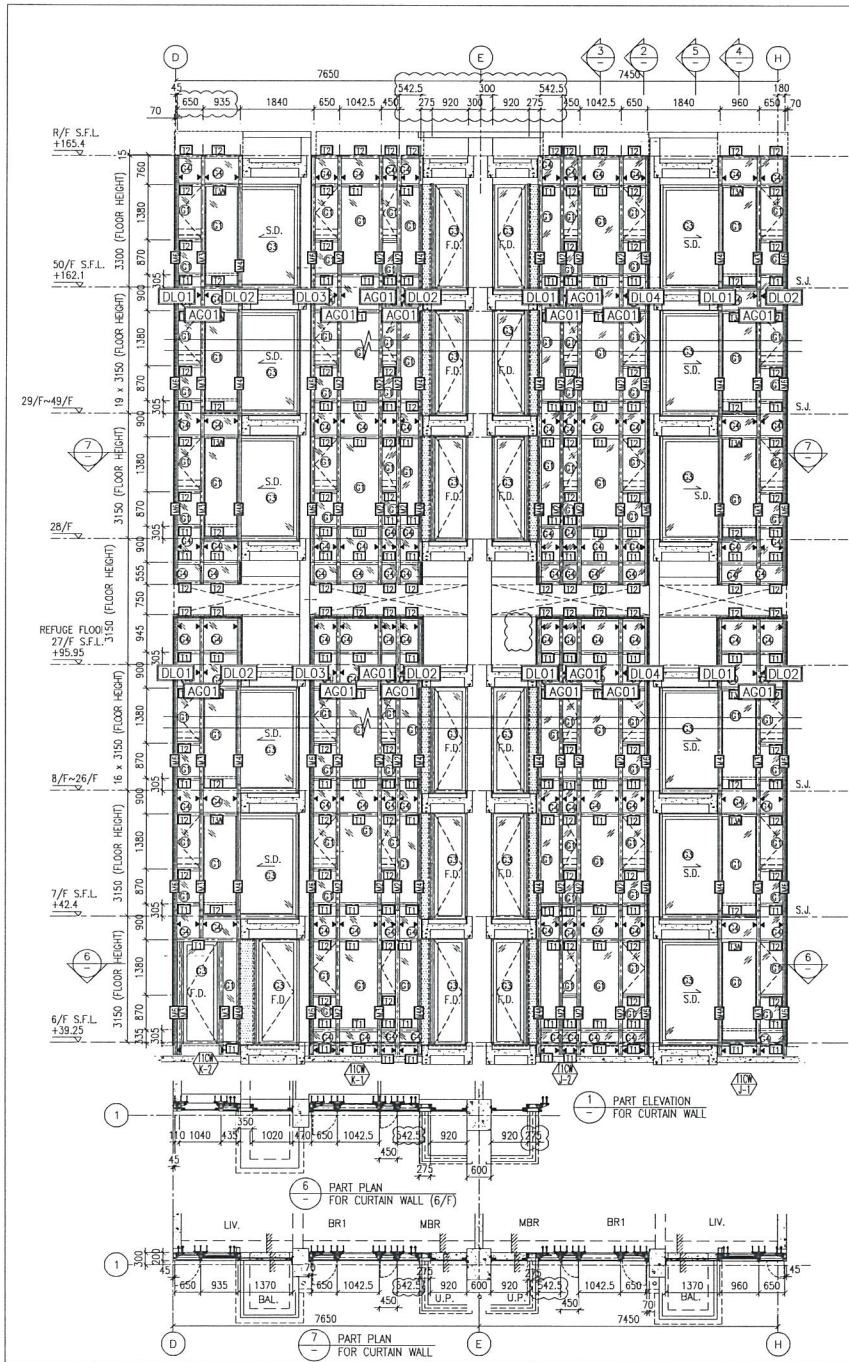

- LEGEND:**
- 10 mm THK. TEMPERED BLUE GLASS (OUTER) + 9 mm AIR SPACE + 10 mm THK. TEMPERED GLASS (INNER)
 - 6 mm THK. TEMPERED BLUE GLASS (OUTER) + 9 mm AIR SPACE + 6 mm THK. TEMPERED GLASS (INNER)
 - 10 mm THK. TEMPERED BLUE TINTED GLASS
 - 8 mm THK. HEAT STRENGTHENED BLUE TINTED GLASS (SPANDREL GLASS)
 - 8 mm THK. TEMPERED BLUE TINTED GLASS (SPANDREL GLASS)
 - 10 mm THK. TEMPERED GLASS (INTERNAL PROTECTIVE BARRIER)
 - 3 mm THK. ALUM. CLADDING
 - M.W. - MAINTENANCE WINDOW
 - S.J. - STACK JOINT
 - ACO1 - ALUM. EXTRUSION DIE NO.
 - SUPPORT POINT

B.D. REF :	
CLIENT : Sino Land Company Limited	
ARCHITECT : WONG TUNG & PARTNERS LIMITED ARCHITECTS & PLANNERS	
MAIN CONTRACTOR : CR Construction Company Limited	
STRUCTURAL ENGINEER : AECOM	
FACADE CONSULTANT: AECOM	
NOTE : 1. ALL DIMENSIONS ARE IN mm. 2. ALL ELEVATIONS ARE VIEWED FROM OUTSIDE. 3. ALL DIMENSIONS TO BE VERIFIED ON SITE BEFORE FABRICATION.	
LEGEND : - DETAIL MARK NO. - REFER SHEET NO.	
1. F.F.L. -- FINISHED FLOOR LEVEL 2. S.F.L. -- STRUCTURAL FLOOR LEVEL 3. (R) -- REVERSED DETAIL	
B	12/10/2018 GENERAL REVISED
A	10/9/2018 GENERAL REVISED
REV	DATE REVISION BY
JOB NO. : J-837	
PROJECT : URA KWUN TONG TOWN CENTRE REDEVELOPMENT (AREA 2 & 3) AT NKIL 6514, KWUN TONG, KWLOON	
TITLE : PART ELEVATION OF CURTAIN WALL AT TOWER 1	
DATE : 04-JUL-18	SCALE : 1:60 (A1)
DRAWN BY : ASING CHECKED BY : -	
英特鋁質有限公司 Units 6-8, Sunny Industrial Centre, 1/F 610 Cho Kwo Ling Road, Kwloon Tel:23489211-4 Fax:(852)27272666	
DWG NO. : JB37-CW-2112	REV. : B

P-30

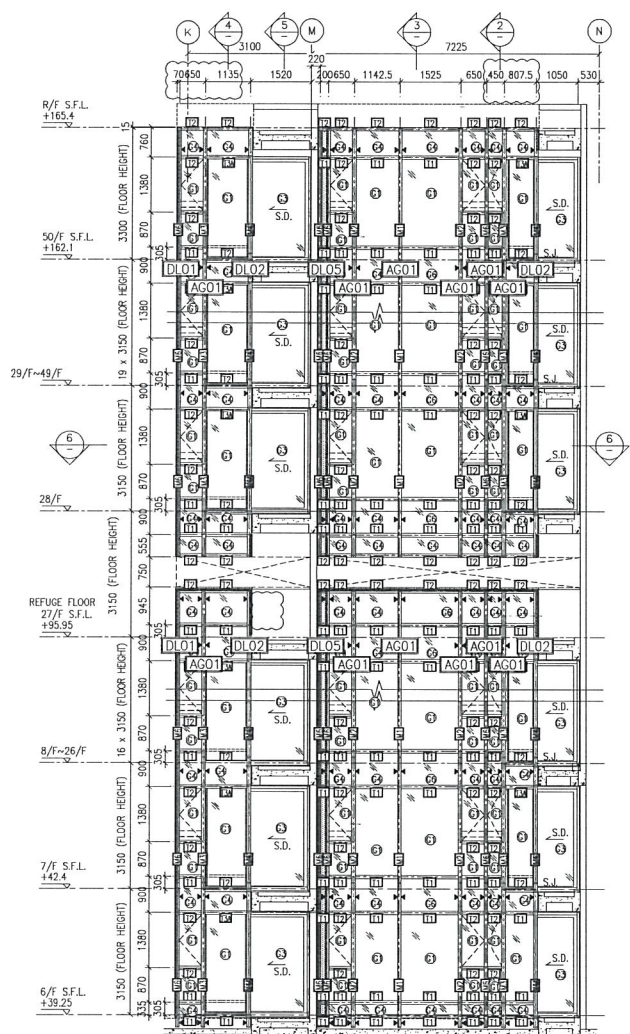

1 PART ELEVATION FOR CURTAIN WALL

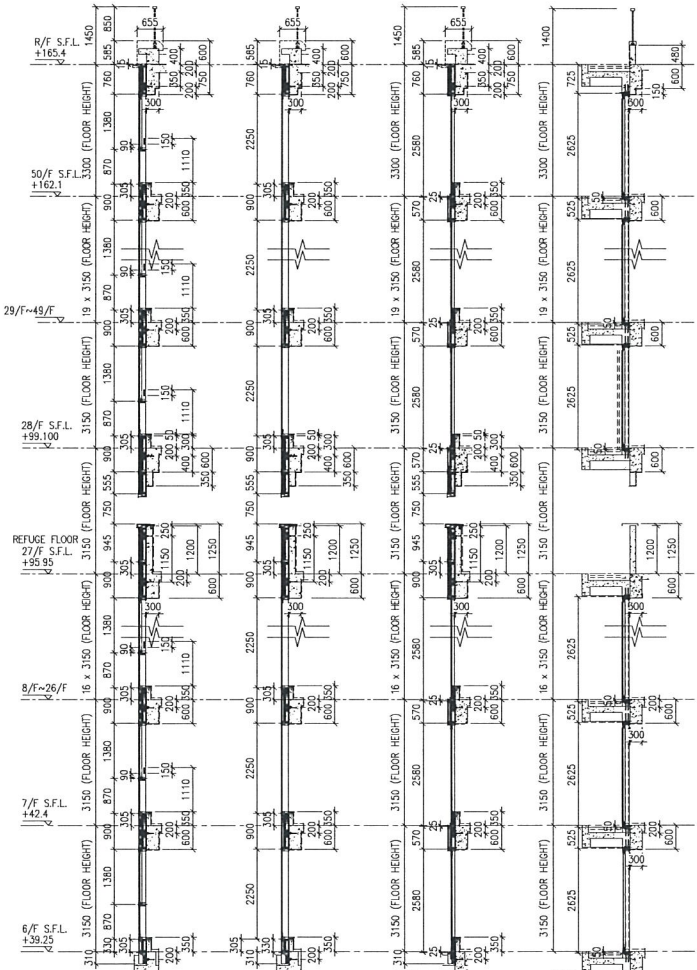

2 TYPICAL SECTION FOR CURTAIN WALL

3 TYPICAL SECTION FOR CURTAIN WALL

4 TYPICAL SECTION FOR CURTAIN WALL

5 TYPICAL SECTION FOR CURTAIN WALL

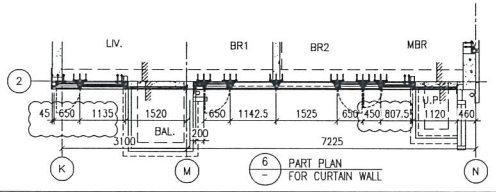

6 PART PLAN FOR CURTAIN WALL

- LEGEND:
- 10 mm THK. TEMPERED BLUE GLASS (OUTER) + 9 mm AIR SPACE + 10 mm THK. TEMPERED GLASS (INNER)
 - 6 mm THK. TEMPERED BLUE GLASS (OUTER) + 9 mm AIR SPACE + 6 mm THK. TEMPERED GLASS (INNER)
 - 10 mm THK. TEMPERED BLUE TINTED GLASS
 - 8 mm THK. HEAT STRENGTHENED BLUE TINTED GLASS (SPANDREL GLASS)
 - 8 mm THK. TEMPERED BLUE TINTED GLASS (SPANDREL GLASS)
 - 10 mm THK. TEMPERED GLASS (INTERNAL PROTECTIVE BARRIER)
 - 3 mm THK. ALUM. CLADDING
 - M.W. - MAINTENANCE WINDOW
 - S.J. - STACK JOINT
 - A.G.O.1 - ALUM. EXTRUSION DIE NO.
 - SUPPORT POINT

B.D. REF :	
CLIENT : 信和置業有限公司 Sino Land Company Limited	
ARCHITECT : WONG TUNG & PARTNERS LIMITED ARCHITECTS & PLANNERS	
MAIN CONTRACTOR : CR Construction Company Limited	
STRUCTURAL ENGINEER : AZCOM	
FACADE CONSULTANT : AZCOM	
NOTE: 1. ALL DIMENSIONS ARE IN mm. 2. ALL ELEVATIONS ARE VIEWED FROM OUTSIDE. 3. ALL DIMENSIONS TO BE VERIFIED ON SITE BEFORE FABRICATION.	
LEGEND: X1 - DETAIL MARK NO. X000 - REFER SHEET NO.	
1. F.F.L. - FINISHED FLOOR LEVEL 2. S.F.L. - STRUCTURAL FLOOR LEVEL 3. (R) - REVERSED DETAIL	
A	10/9/2018 GENERAL REVISED
NO	DATE REVISION BY
JOB NO. : J-837	
PROJECT : URA KWUN TONG TOWN CENTRE REDEVELOPMENT (AREA 2 & 3) AT NKIL 6514, KWUN TONG, KWLOON	
TITLE : PART ELEVATION OF CURTAIN WALL AT TOWER 1	
DATE : 04-JUL-18	SCALE : 1:60 (A1)
DRAWN BY : ASING	CHECKED BY : -
美特鋁質有限公司 MIDI ALUMINIUM FABRICATOR LTD. Units 5-8, Sunray Industrial Centre, 1/F 610 Che Kwo Ling Road, Kwloon Tel:23489211-4 Fax:(852)2727666	
DWG NO. : J837-CW-2113	REV. : A

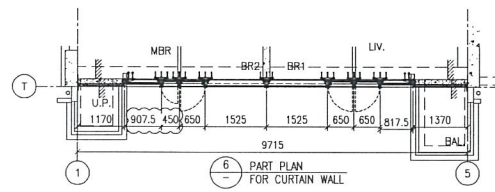
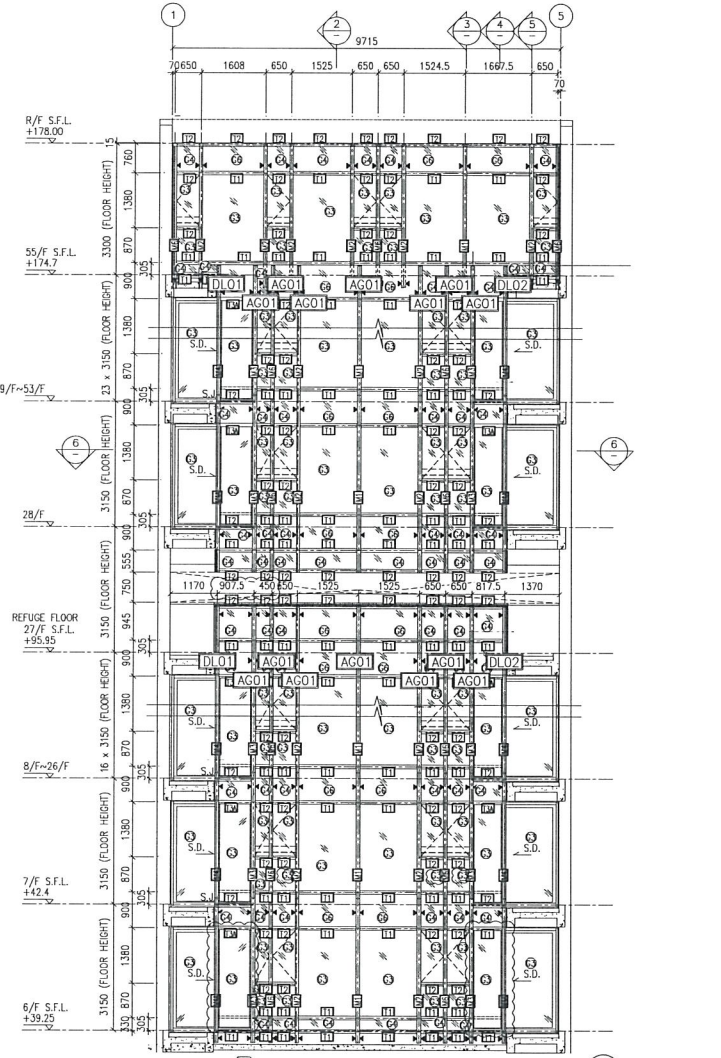

1 PART ELEVATION FOR CURTAIN WALL

6 PART PLAN FOR CURTAIN WALL

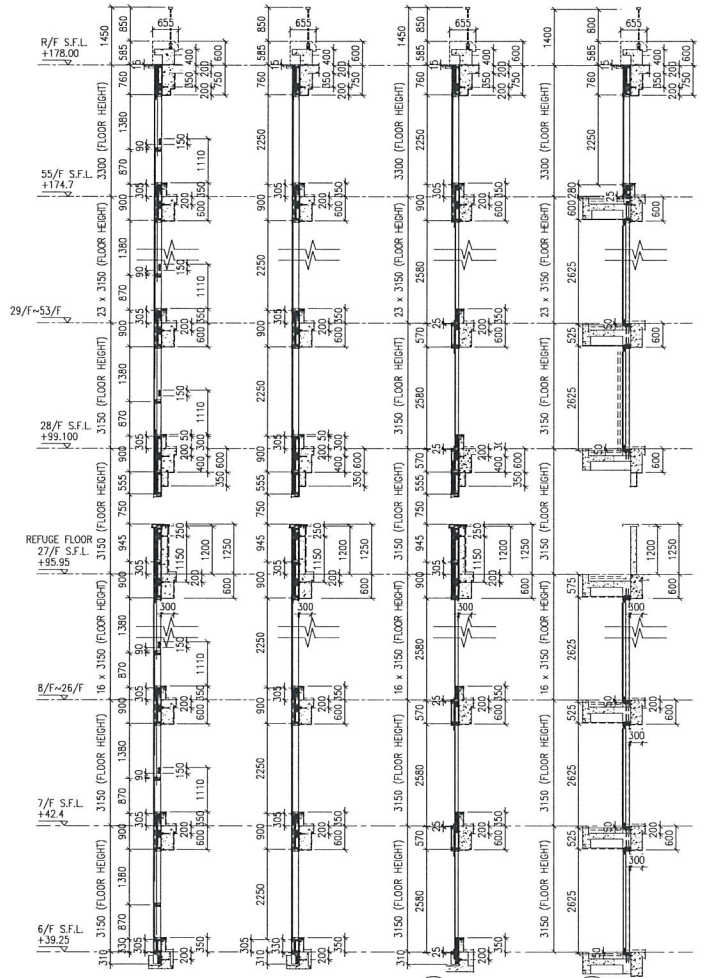

2 TYPICAL SECTION FOR CURTAIN WALL

3 TYPICAL SECTION FOR CURTAIN WALL

4 TYPICAL SECTION FOR CURTAIN WALL

5 TYPICAL SECTION FOR CURTAIN WALL

- LEGEND:
- 10 mm THK. TEMPERED BLUE GLASS (OUTER) + 9 mm AIR SPACE + 10 mm THK. TEMPERED GLASS (INNER)
 - 6 mm THK. TEMPERED BLUE GLASS (OUTER) + 9 mm AIR SPACE + 6 mm THK. TEMPERED GLASS (INNER)
 - 10 mm THK. TEMPERED BLUE TINTED GLASS
 - 8 mm THK. HEAT STRENGTHENED BLUE TINTED GLASS (SPANDREL GLASS)
 - 8 mm THK. TEMPERED BLUE TINTED GLASS (SPANDREL GLASS)
 - 10 mm THK. TEMPERED GLASS (INTERNAL PROTECTIVE BARRIER)
 - 3 mm THK. ALUM. CLADDING
 - M.W. - MAINTENANCE WINDOW
 - S.J. - STACK JOINT
 - ALO1 - ALUM. EXTRUSION DIE NO.
 - ▲ - SUPPORT POINT

B.D. REF :	
CLIENT : Sino Land Company Limited	
ARCHITECT : WONG TUNG & PARTNERS LIMITED	
MAIN CONTRACTOR : CR Construction Company Limited	
STRUCTURAL ENGINEER : ACCOM	
FACADE CONSULTANT : ACCOM	
NOTE : 1. ALL DIMENSIONS ARE IN mm. 2. ALL ELEVATIONS ARE VIEWED FROM OUTSIDE. 3. ALL DIMENSIONS TO BE VERIFIED ON SITE BEFORE FABRICATION.	
LEGEND : X1 - DETAIL MARK NO. X001 - REFER SHEET NO.	
1. F.F.L. -- FINISHED FLOOR LEVEL 2. S.F.L. -- STRUCTURAL FLOOR LEVEL 3. (R) -- REVERSED DETAIL	
B	12/10/2018 GENERAL REWSED
A	10/9/2018 GENERAL REWSED
MS	DATE REWSED BY
JOB NO. : J-837	
PROJECT : URA KWUN TONG TOWN CENTRE REDEVELOPMENT (AREA 2 & 3) AT NKIL 6514, KWUN TONG, KWLOON	
TITLE : PART ELEVATION OF CURTAIN WALL AT TOWER 2	
DATE : 04-JUL-18	SCALE : 1:60 (A1)
DRAWN BY : ASING	CHECKED BY : -
美特鋁質有限公司 MIDI ALUMINIUM FABRICATOR LTD. Units 6-8, Sunny Industrial Centre, 1/F 810 Che Kwo Ling Road, Kwloon Tel:23489211-4 Fax:(852)27272666	
DWG NO. : JB37-CW-2201	REV. : B

P-3~

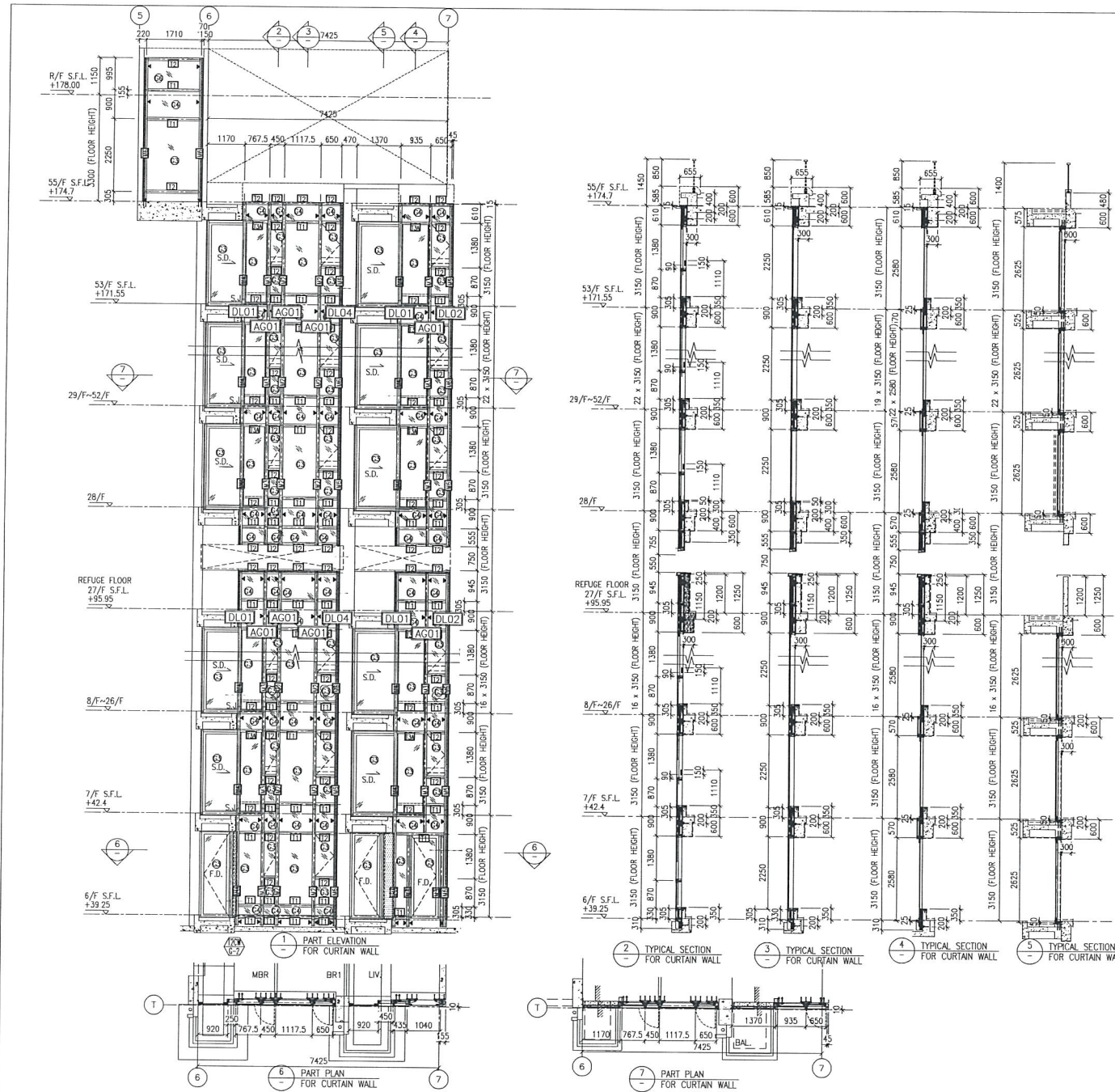

- LEGEND:**
- 10 mm THK. TEMPERED BLUE GLASS (OUTER) + 9 mm AIR SPACE + 10 mm THK. TEMPERED GLASS (INNER)
 - 6 mm THK. TEMPERED BLUE GLASS (OUTER) + 9 mm AIR SPACE + 6 mm THK. TEMPERED GLASS (INNER)
 - 10 mm THK. TEMPERED BLUE TINTED GLASS
 - 8 mm THK. HEAT STRENGTHENED BLUE TINTED GLASS (SPANDREL GLASS)
 - 8 mm THK. TEMPERED BLUE TINTED GLASS (SPANDREL GLASS)
 - 10 mm THK. TEMPERED GLASS (INTERNAL PROTECTIVE BARRIER)
 - 3 mm THK. ALUM. CLADDING
 - MAINTENANCE WINDOW
 - STACK JOINT
 - ALUM. EXTRUSION DIE NO.
 - SUPPORT POINT

B.D. REF :

CLIENT :
 Sino Land Company Limited

ARCHITECT :
 WONG TUNG & PARTNERS LIMITED
 ARCHITECTS & PLANNERS

MAIN CONTRACTOR :
 CR Construction Company Limited

STRUCTURAL ENGINEER :
 ACOM

FAÇADE CONSULTANT:
 ACOM

NOTE :
 1. ALL DIMENSIONS ARE IN mm.
 2. ALL ELEVATIONS ARE VIEWED FROM OUTSIDE.
 3. ALL DIMENSIONS TO BE VERIFIED ON SITE BEFORE FABRICATION.

LEGEND :
 (X1) DETAIL MARK NO.
 (X001) REFER SHEET NO.

1. F.F.L. --- FINISHED FLOOR LEVEL
 2. S.F.L. --- STRUCTURAL FLOOR LEVEL
 3. (R) --- REVERSED DETAIL

B	12/10/2018	GENERAL REVISED
A	10/9/2018	GENERAL REVISED
NO.	DATE	REVISED
		BY

JOB NO. : J-837

PROJECT :
 URA KWUN TONG TOWN CENTRE
 REDEVELOPMENT (AREA 2 & 3) AT
 NKIL 6514, KWUN TONG, KWLOON

TITLE :
 PART ELEVATION
 OF CURTAIN WALL
 AT TOWER 2

DATE : 04-JUL-18 SCALE : 1:60 (A1)

DRAWN BY : ASING CHECKED BY : -

美特鋁質有限公司
 MIDI ALUMINIUM FABRICATOR LTD.
 Units 6-8, Sunray Industrial Centre, 1/F
 610 Che Kwo Ling Road, Kowloon
 Tel:23489211-4 Fax:85227727666

DWG NO. : J837-CW-2202 REV. : B

P.33

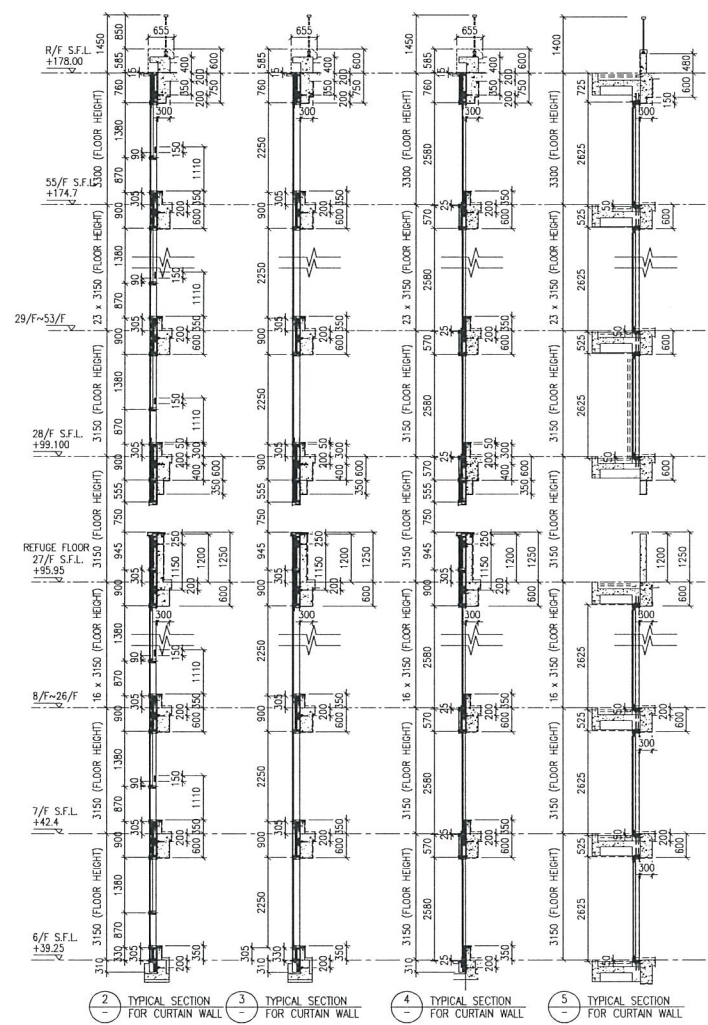
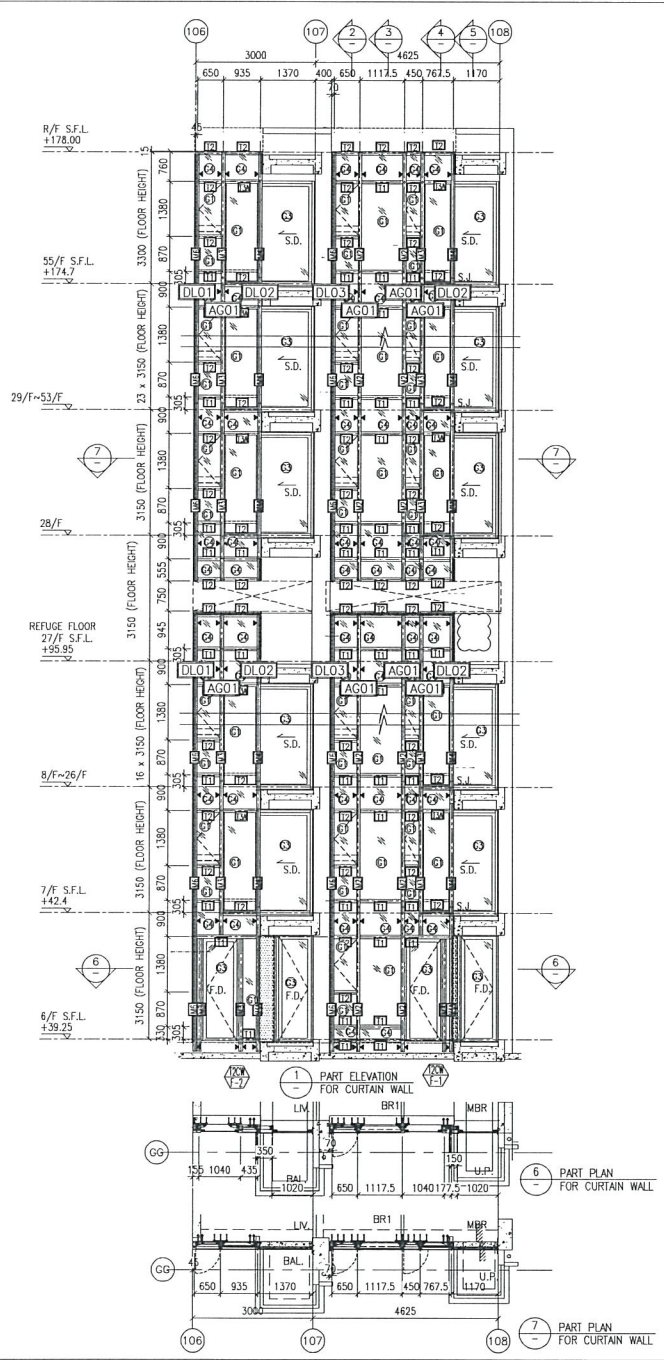

- LEGEND:**
- 10 mm THK. TEMPERED BLUE GLASS (OUTER) + 9 mm AIR SPACE + 10 mm THK. TEMPERED GLASS (INNER)
 - 6 mm THK. TEMPERED BLUE GLASS (OUTER) + 9 mm AIR SPACE + 6 mm THK. TEMPERED GLASS (INNER)
 - 10 mm THK. TEMPERED BLUE TINTED GLASS
 - 8 mm THK. HEAT STRENGTHENED BLUE TINTED GLASS (SPANDREL GLASS)
 - 8 mm THK. TEMPERED BLUE TINTED GLASS (SPANDREL GLASS)
 - 10 mm THK. TEMPERED GLASS (INTERNAL PROTECTIVE BARRIER)
 - 3 mm THK. ALUM. CLADDING
 - M.W. - MAINTENANCE WINDOW
 - S.J. - STACK JOINT
 - ACO1 - ALUM. EXTRUSION DIE NO.
 - ▲ - SUPPORT POINT

B.D. REF :	
CLIENT : Sino Land Company Limited	
ARCHITECT : WONG TUNG & PARTNERS LIMITED ARCHITECTS & PLANNERS	
MAIN CONTRACTOR : CR Construction Company Limited	
STRUCTURAL ENGINEER : ACOM	
FACADE CONSULTANT : ACOM	
NOTE: 1. ALL DIMENSIONS ARE IN mm. 2. ALL ELEVATIONS ARE VIEWED FROM OUTSIDE. 3. ALL DIMENSIONS TO BE VERIFIED ON SITE BEFORE FABRICATION.	
LEGEND: X1 - DETAIL MARK NO. REF - REFER SHEET NO.	
1. F.F.L. --- FINISHED FLOOR LEVEL 2. S.F.L. --- STRUCTURAL FLOOR LEVEL 3. (P) --- REVERSED DETAIL	
A	10/9/2018 GENERAL REVISED
REV	DATE
REVISED	BY
JOB NO. : J-837	
PROJECT : URA KWUN TONG TOWN CENTRE REDEVELOPMENT (AREA 2 & 3) AT NKIL 6514, KWUN TONG, KWLOON	
TITLE : PART ELEVATION OF CURTAIN WALL AT TOWER 2	
DATE : 04-JUL-18	SCALE : 1:60 (A1)
DRAWN BY : ASING	CHECKED BY : -
MIDI ALUMINIUM FABRICATOR LTD. Units 5-8, Sunny Industrial Centre, 1/F 610 Cho Kwo Ling Road, Kwloon Tel:23489211-4 Fax:(852)2727666	
DWG NO. : JB37-CW-2203	REV. : A

P.34

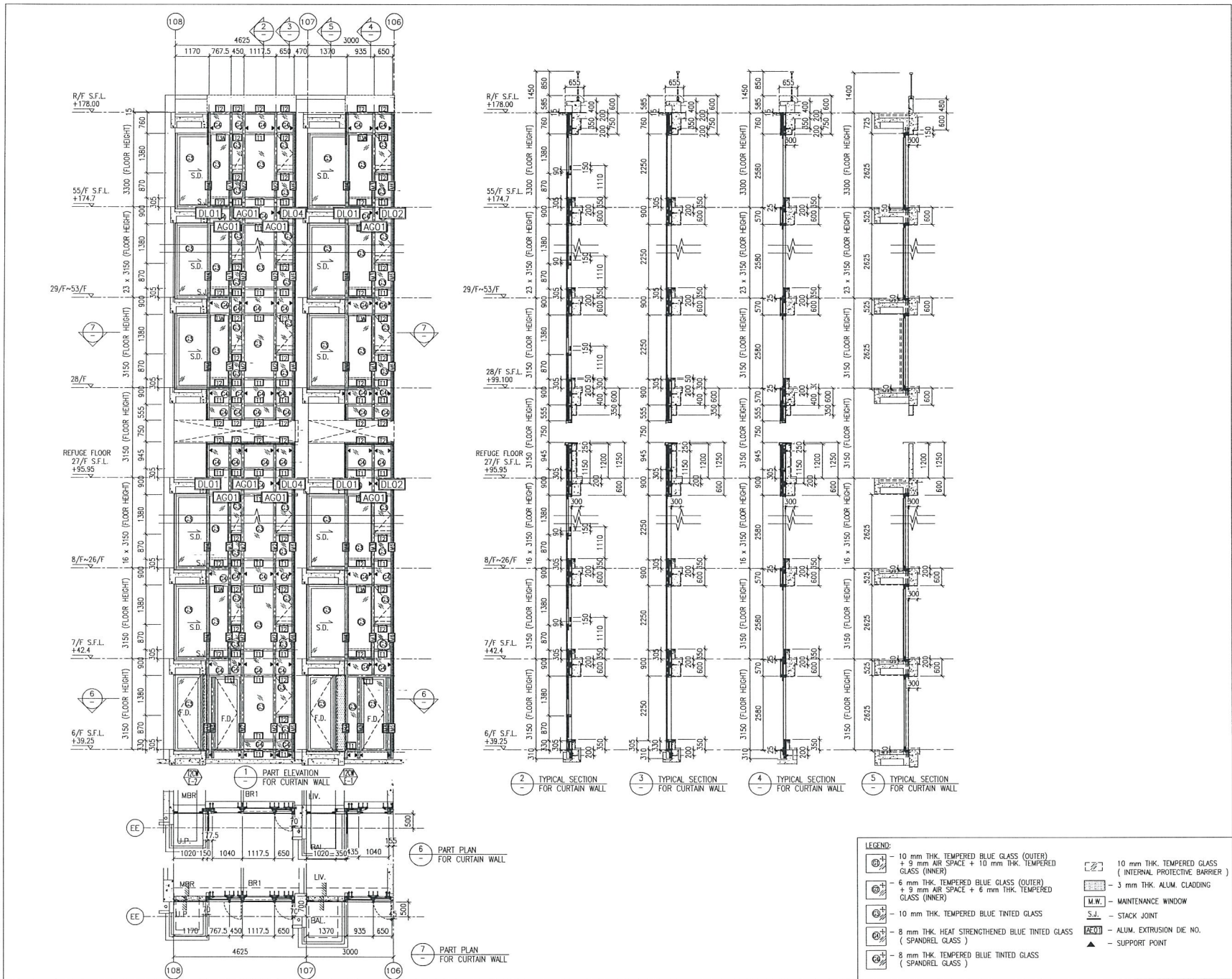

B.D. REF :

CLIENT :
 Sino Land Company Limited

ARCHITECT :
 WONG TUNG & PARTNERS LIMITED
 ARCHITECTS & PLANNERS

MAIN CONTRACTOR :
 CR Construction Company Limited

STRUCTURAL ENGINEER :
 AECOM

FAÇADE CONSULTANT :
 AECOM

NOTE :
 1. ALL DIMENSIONS ARE IN mm.
 2. ALL ELEVATIONS ARE VIEWED FROM OUTSIDE.
 3. ALL DIMENSIONS TO BE VERIFIED ON SITE BEFORE FABRICATION.

LEGEND :
 (X1) -- DETAIL MARK NO.
 (A001) -- REFER SHEET NO.
 1. F.F.L. -- FINISHED FLOOR LEVEL
 2. S.F.L. -- STRUCTURAL FLOOR LEVEL
 3. (R) -- REVERSED DETAIL

B	12/10/2018	GENERAL REVISED
A	10/9/2018	GENERAL REVISED
REV	DATE	REVISION

JOB NO. : J-837
 PROJECT :
 URA KWUN TONG TOWN CENTRE
 REDEVELOPMENT (AREA 2 & 3) AT
 NKIL 6514, KWUN TONG, KWLOON

TITLE :
 PART ELEVATION
 OF CURTAIN WALL
 AT TOWER 2

DATE : 04-JUL-18 SCALE : 1:60 (A1)
 DRAWN BY : ASING CHECKED BY : -

美特鋁質有限公司
 MIDI ALUMINUM FABRICATOR LTD.
 Units 5-8, Sunny Industrial Centre, 1/F
 610 Chee Kwo Ling Road, Kwai Tsan
 Tel:23489211-4 Fax:(852)2727666
 DWG NO. : JB37-CW-2204 REV. : B

- LEGEND:
- 10 mm THK. TEMPERED BLUE GLASS (OUTER) + 9 mm AIR SPACE + 10 mm THK. TEMPERED GLASS (INNER)
 - 6 mm THK. TEMPERED BLUE GLASS (OUTER) + 9 mm AIR SPACE + 6 mm THK. TEMPERED GLASS (INNER)
 - 10 mm THK. TEMPERED BLUE TINTED GLASS
 - 8 mm THK. HEAT STRENGTHENED BLUE TINTED GLASS (SPANDREL GLASS)
 - 8 mm THK. TEMPERED BLUE TINTED GLASS (SPANDREL GLASS)
 - 10 mm THK. TEMPERED GLASS (INTERNAL PROTECTIVE BARRIER)
 - 3 mm THK. ALUM. CLADDING
 - MAINTENANCE WINDOW
 - STACK JOINT
 - ALUM. EXTRUSION DIE NO.
 - SUPPORT POINT

P. 35

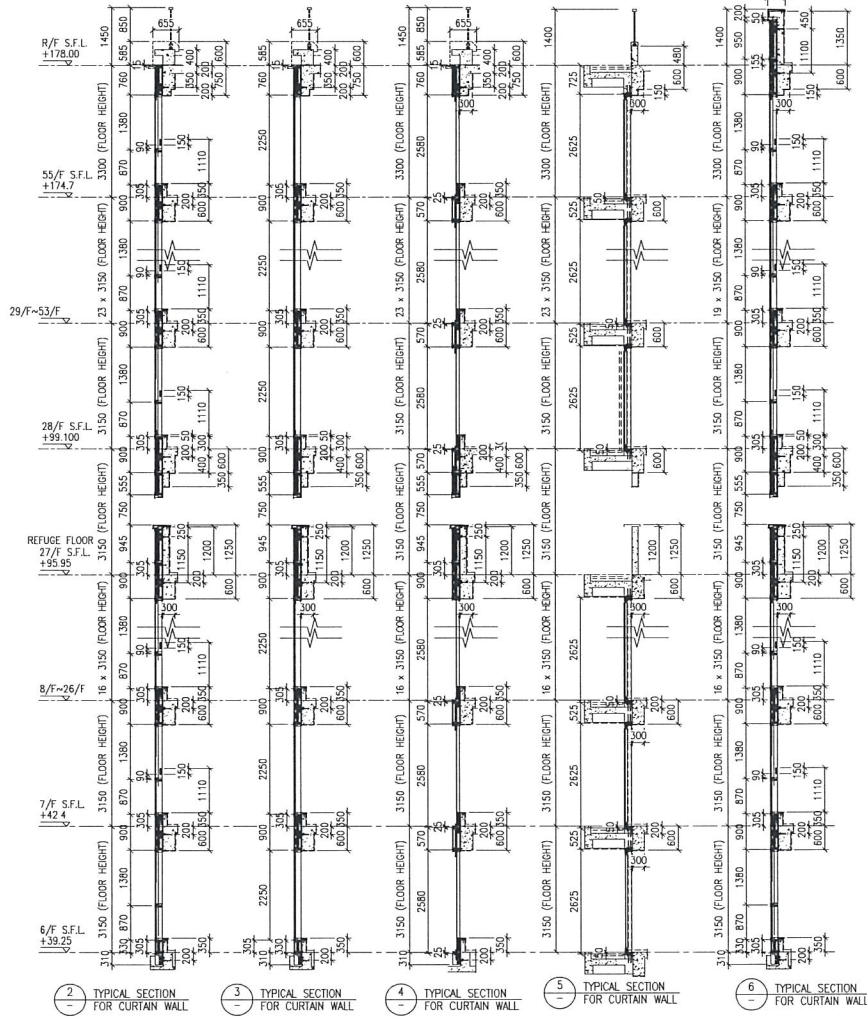
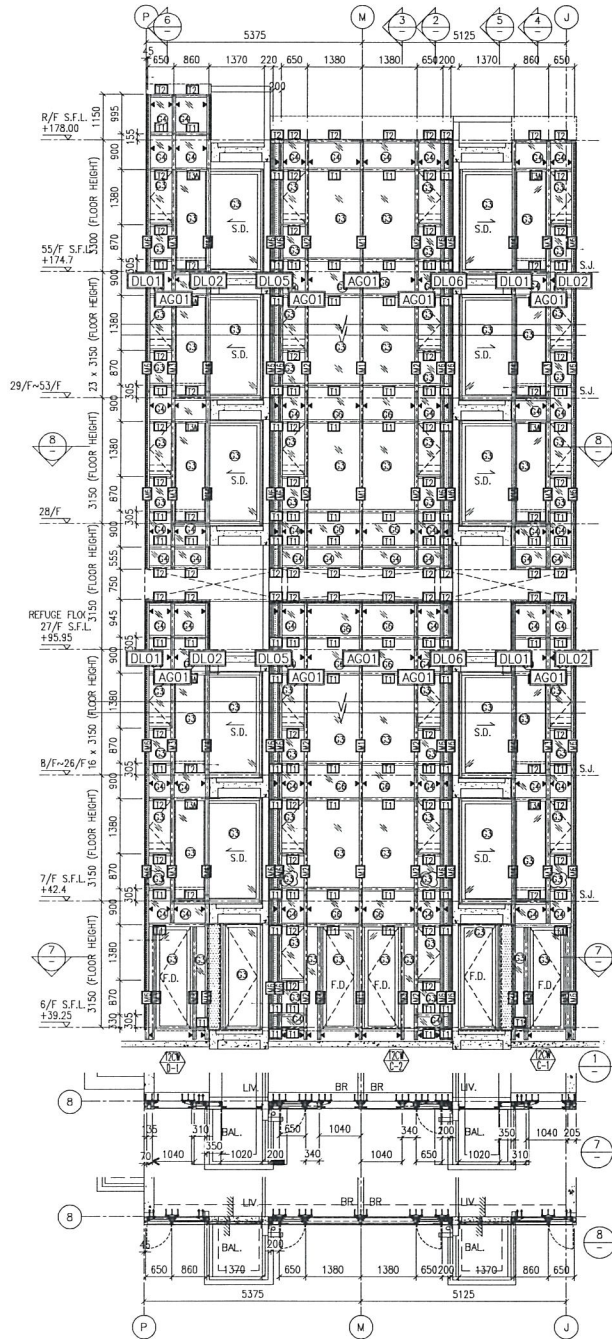

- LEGEND:**
- 10 mm THK. TEMPERED BLUE GLASS (OUTER) + 9 mm AIR SPACE + 10 mm THK. TEMPERED GLASS (INNER)
 - 6 mm THK. TEMPERED BLUE GLASS (OUTER) + 9 mm AIR SPACE + 6 mm THK. TEMPERED GLASS (INNER)
 - 10 mm THK. TEMPERED BLUE TINTED GLASS
 - 8 mm THK. HEAT STRENGTHENED BLUE TINTED GLASS (SPANDREL GLASS)
 - 8 mm THK. TEMPERED BLUE TINTED GLASS (SPANDREL GLASS)
 - 10 mm THK. TEMPERED GLASS (INTERNAL PROTECTIVE BARRIER)
 - 3 mm THK. ALUM. CLADDING
 - MAINTENANCE WINDOW
 - STACK JOINT
 - ALUM. EXTRUSION DIE NO.
 - SUPPORT POINT

B.D. REF :

CLIENT : Sino Land Company Limited

ARCHITECT : WONG TUNG & PARTNERS LIMITED ARCHITECTS & PLANNERS

MAIN CONTRACTOR : CR Construction Company Limited

STRUCTURAL ENGINEER : ACCOM

FAÇADE CONSULTANT : ACCOM

NOTE:

- ALL DIMENSIONS ARE IN mm.
- ALL ELEVATIONS ARE VIEWED FROM OUTSIDE.
- ALL DIMENSIONS TO BE VERIFIED ON SITE BEFORE FABRICATION.

LEGEND:

- DETAIL MARK NO.
- REFER SHEET NO.

- F.F.L. - FINISHED FLOOR LEVEL
- S.F.L. - STRUCTURAL FLOOR LEVEL
- REVERSED DETAIL

B	12/10/2018	GENERAL REVISED	
A	10/9/2018	GENERAL REVISED	
REV	DATE	REVISION	BY

JOB NO. : J-837

PROJECT : URA KWUN TONG TOWN CENTRE REDEVELOPMENT (AREA 2 & 3) AT NKIL 6514, KWUN TONG, KWLOON

TITLE : PART ELEVATION OF CURTAIN WALL AT TOWER 2

DATE : 04-JUL-18 SCALE : 1:60 (A1)

DRAWN BY : ASING CHECKED BY : -

美特銘質有限公司
 MTI ALUMINIUM FABRICATOR LTD.
 Units 5-8, Sunny Industrial Centre, 1/F
 610 Cha Kwo Ling Road, Kwloon
 Tel:23489211-4 Fax:(852)2727666

DWG NO. : J837-CW-2205 REV. : B

P.36

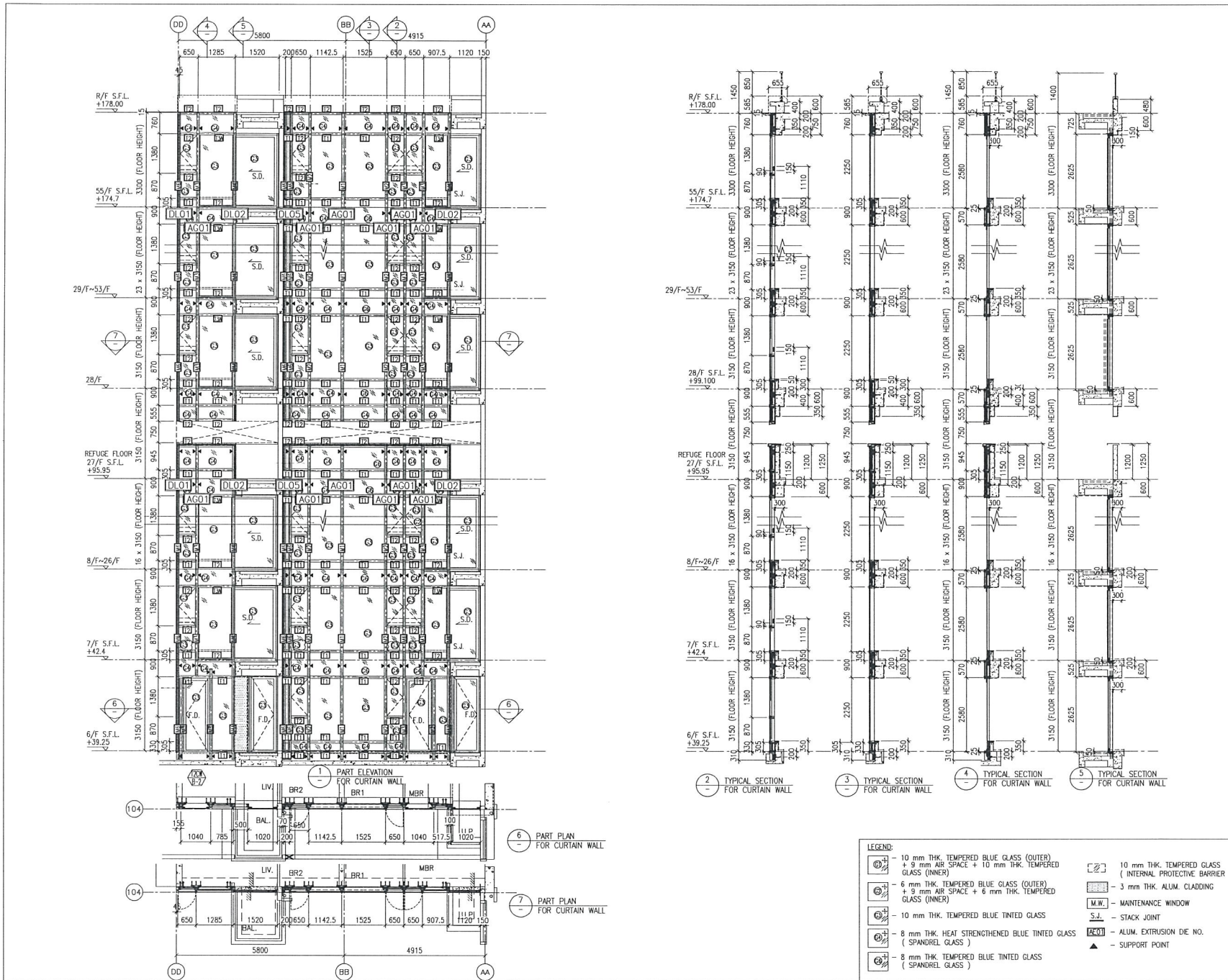

B.D. REF :

CLIENT : 信和置業有限公司
Sino Land Company Limited

ARCHITECT : WONG TUNG & PARTNERS LIMITED
ARCHITECTS & PLANNERS

MAIN CONTRACTOR : CR Construction Company Limited

STRUCTURAL ENGINEER : ACOM

FACADE CONSULTANT : ACOM

NOTE:
1. ALL DIMENSIONS ARE IN mm.
2. ALL ELEVATIONS ARE VENEYED FROM OUTSIDE.
3. ALL DIMENSIONS TO BE VERIFIED ON SITE BEFORE FABRICATION.

LEGEND:
 (M) - DETAIL MARK NO.
 (R) - REFER SHEET NO.

1. F.F.L. -- FINISHED FLOOR LEVEL
 2. S.F.L. -- STRUCTURAL FLOOR LEVEL
 3. (R) -- REVERSED DETAIL

B	12/10/2018	GENERAL REWSED
A	10/9/2018	GENERAL REWSED
REV	DATE	REWSD BY

JOB NO. : J-837

PROJECT : URA KWUN TONG TOWN CENTRE REDEVELOPMENT (AREA 2 & 3) AT NKIL 6514, KWUN TONG, KWLOON

TITLE : PART ELEVATION OF CURTAIN WALL AT TOWER 2

DATE : 04-JUL-18	SCALE : 1:60 (A1)
DRAWN BY : ASING	CHECKED BY : -

英特鋁質有限公司
MIDI ALUMINIUM FABRICATOR LTD.
Units 6-8, Sunray Industrial Centre, 1/F
610 Cha Kwo Ling Road, Kwloon
Tel:23489211-4 Fax:(852)27272666

DWG NO. : JB37-CW-2206 REV. : B

P-37

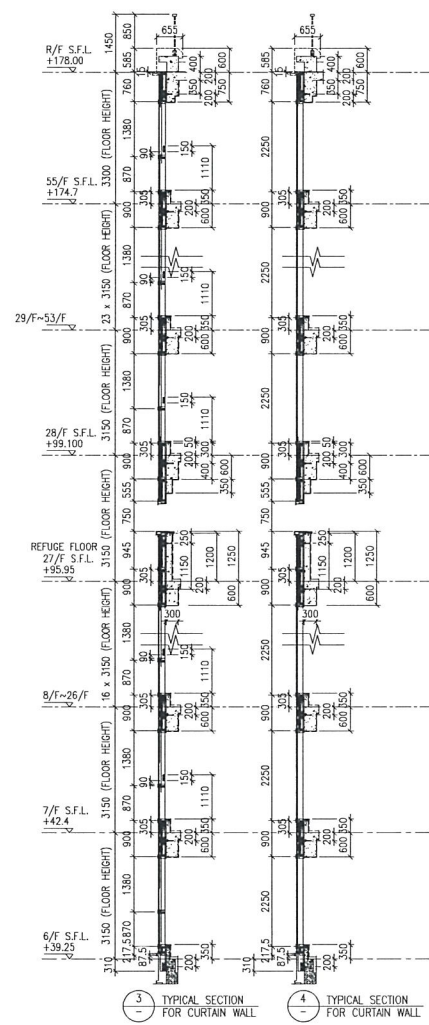
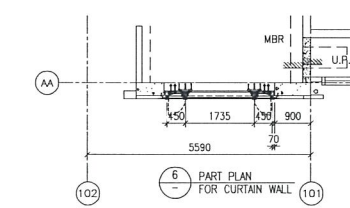
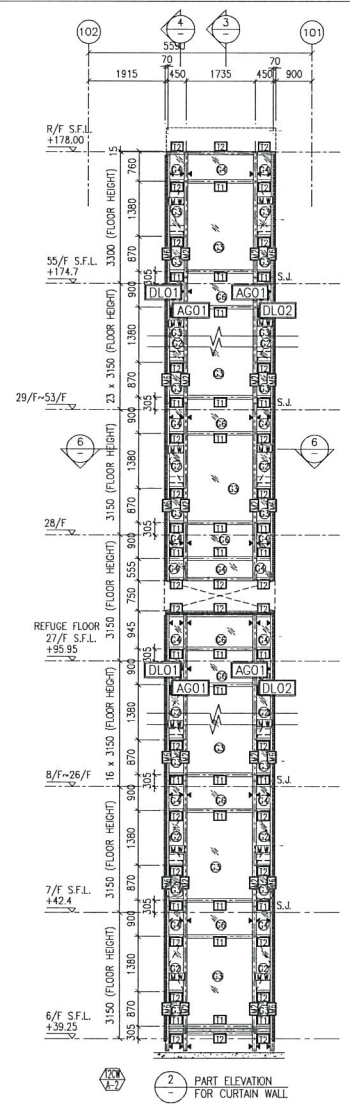
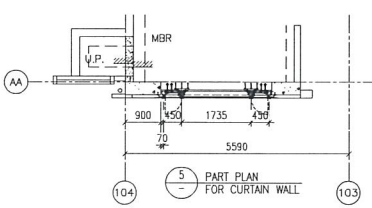
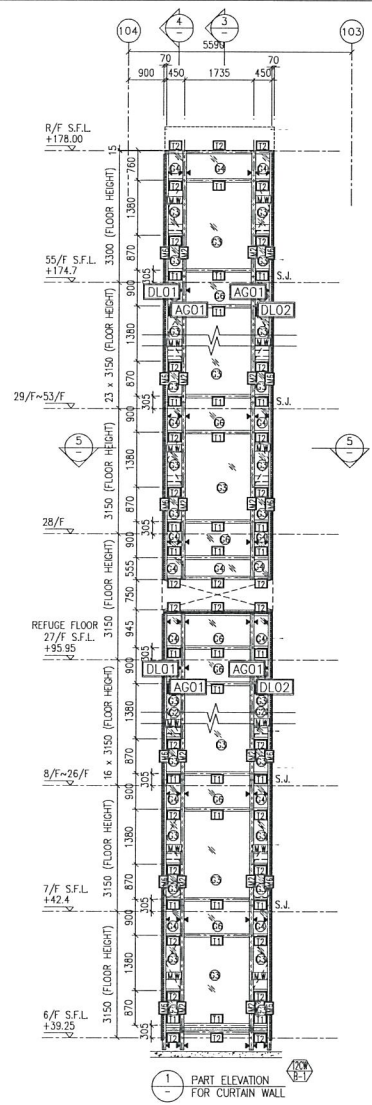

LEGEND:

	10 mm THK. TEMPERED BLUE GLASS (OUTER) + 9 mm AIR SPACE + 10 mm THK. TEMPERED GLASS (INNER)		10 mm THK. TEMPERED GLASS (INTERNAL PROTECTIVE BARRIER)
	6 mm THK. TEMPERED BLUE GLASS (OUTER) + 9 mm AIR SPACE + 6 mm THK. TEMPERED GLASS (INNER)		3 mm THK. ALUM. CLADDING
	10 mm THK. TEMPERED BLUE TINTED GLASS		M.W. - MAINTENANCE WINDOW
	8 mm THK. HEAT STRENGTHENED BLUE TINTED GLASS (SPANDELR GLASS)		S.J. - STACK JOINT
	8 mm THK. TEMPERED BLUE TINTED GLASS (SPANDELR GLASS)		AG01 - ALUM. EXTRUSION DIE NO.
	▲ - SUPPORT POINT		

B.D. REF :

CLIENT : 信和置業有限公司 Sino Land Company Limited

ARCHITECT : WONG TUNG & PARTNERS LIMITED ARCHITECTS & PLANNERS

MAN CONTRACTOR : CR Construction Company Limited

STRUCTURAL ENGINEER : ACOM

FACADE CONSULTANT : ACOM

NOTE:

- ALL DIMENSIONS ARE IN mm.
- ALL ELEVATIONS ARE VIEWED FROM OUTSIDE.
- ALL DIMENSIONS TO BE VERIFIED ON SITE BEFORE FABRICATION.

LEGEND:

(X) - DETAIL MARK NO.
(X001) - REFER SHEET NO.

1. F.F.L. - FINISHED FLOOR LEVEL
2. S.F.L. - STRUCTURAL FLOOR LEVEL
3. (R) - REVERSED DETAIL

B	12/10/2018	GENERAL REWSED	
A	10/9/2018	GENERAL REWSED	
REV	DATE	REWSED	BY

JOB NO. : J-837

PROJECT : URA KWUN TONG TOWN CENTRE REDEVELOPMENT (AREA 2 & 3) AT NKIL 6514, KWUN TONG, KWLOON

TITLE : PART ELEVATION OF CURTAIN WALL AT TOWER 2

DATE : 04-JUL-18	SCALE : 1:60 (A1)
DRAWN BY : ASING	CHECKED BY : -

美特鋁質有限公司
MIDI ALUMINUM FABRICATOR LTD.
Units 6-8, Sunray Industrial Centre, 1/F
610 Cha Kwo Ling Road, Kwloon
Tel: 23489211-4 Fax: (852) 27272666

DWG NO. : JB37-CW-2207 REV. : B

P-38

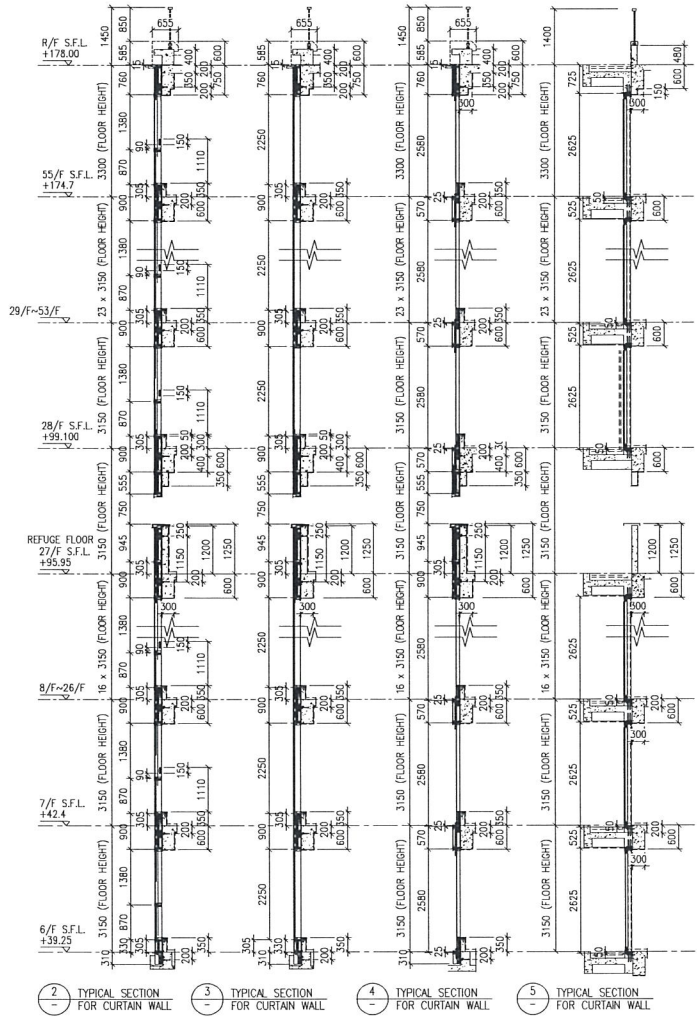
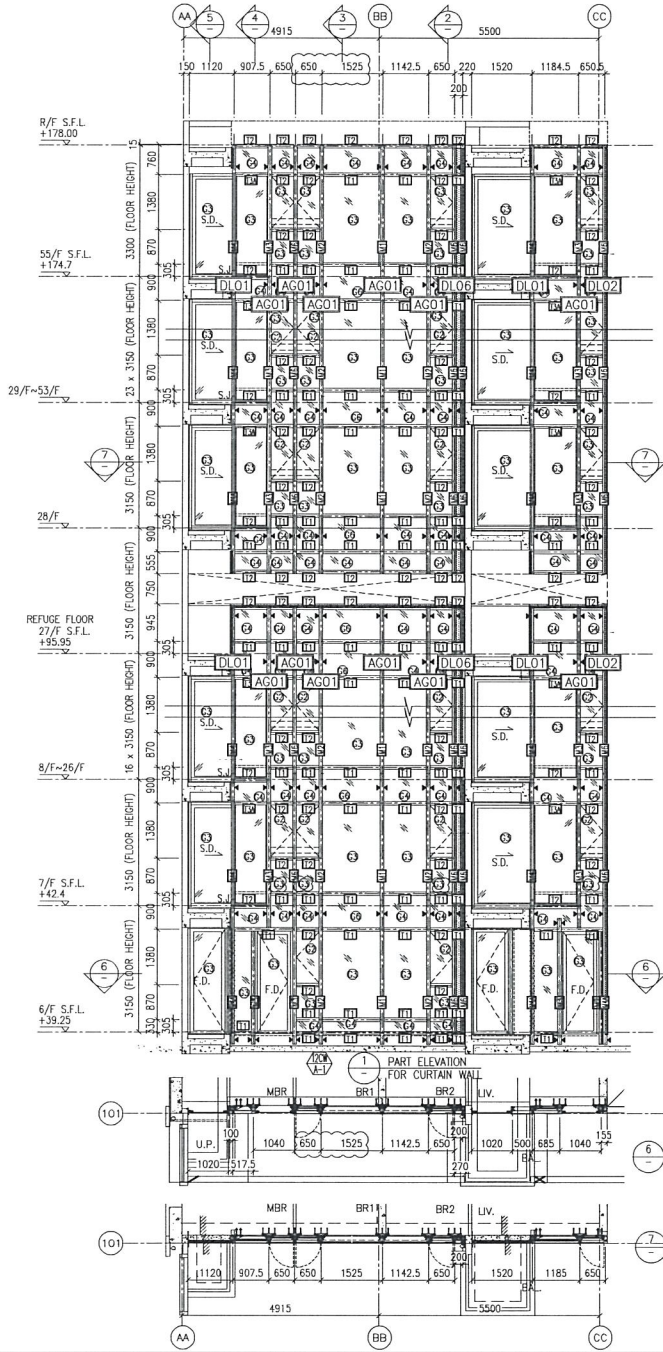

- LEGEND:**
- 10 mm THK. TEMPERED BLUE GLASS (OUTER) + 9 mm AIR SPACE + 10 mm THK. TEMPERED GLASS (INNER)
 - 6 mm THK. TEMPERED BLUE GLASS (OUTER) + 9 mm AIR SPACE + 6 mm THK. TEMPERED GLASS (INNER)
 - 10 mm THK. TEMPERED BLUE TINTED GLASS
 - 8 mm THK. HEAT STRENGTHENED BLUE TINTED GLASS (SPANDREL GLASS)
 - 8 mm THK. TEMPERED BLUE TINTED GLASS (SPANDREL GLASS)
 - 10 mm THK. TEMPERED GLASS (INTERNAL PROTECTIVE BARRIER)
 - 3 mm THK. ALUM. CLADDING
 - M.W. - MAINTENANCE WINDOW
 - S.J. - STACK JOINT
 - A.C.O. - ALUM. EXTRUSION DIE NO.
 - SUPPORT POINT

B.D. REF :

CLIENT :
 Sino Land Company Limited

ARCHITECT :
 WONG TUNG & PARTNERS LIMITED ARCHITECTS & PLANNERS

MAIN CONTRACTOR :
 CR Construction Company Limited

STRUCTURAL ENGINEER :
 AECOM

FACADE CONSULTANT :
 AECOM

NOTE:
 1. ALL DIMENSIONS ARE IN mm.
 2. ALL ELEVATIONS ARE VIEWED FROM OUTSIDE.
 3. ALL DIMENSIONS TO BE VERIFIED ON SITE BEFORE FABRICATION.

LEGEND:
 (X) - DETAIL MARK NO.
 (REF) - REFER SHEET NO.

1. F.F.L. - FINISHED FLOOR LEVEL
 2. S.F.L. - STRUCTURAL FLOOR LEVEL
 3. (R) - REVERSED DETAIL

B	12/10/2018	GENERAL	REVISED
A	10/9/2018	GENERAL	REVISED
REV	DATE	REVISION	BY

JOB NO. : J-837

PROJECT :
 URA KWUN TONG TOWN CENTRE
 REDEVELOPMENT (AREA 2 & 3) AT
 NKIL 6514, KWUN TONG, KWLOON

TITLE :
 PART ELEVATION
 OF CURTAIN WALL
 AT TOWER 2

DATE : 04-JUL-18 SCALE : 1:60 (A1)

DRAWN BY : ASING CHECKED BY : -

美特鋁質有限公司
 MIDI ALUMINIUM FABRICATOR LTD.
 Units 5-8, Sunray Industrial Centre, 1/F
 610 Che Kwo Ling Road, Kwloon
 Tel:23489211-4 Fax:(852)2727666

DWG NO. : JB37-CW-2208 REV. : B

P-39

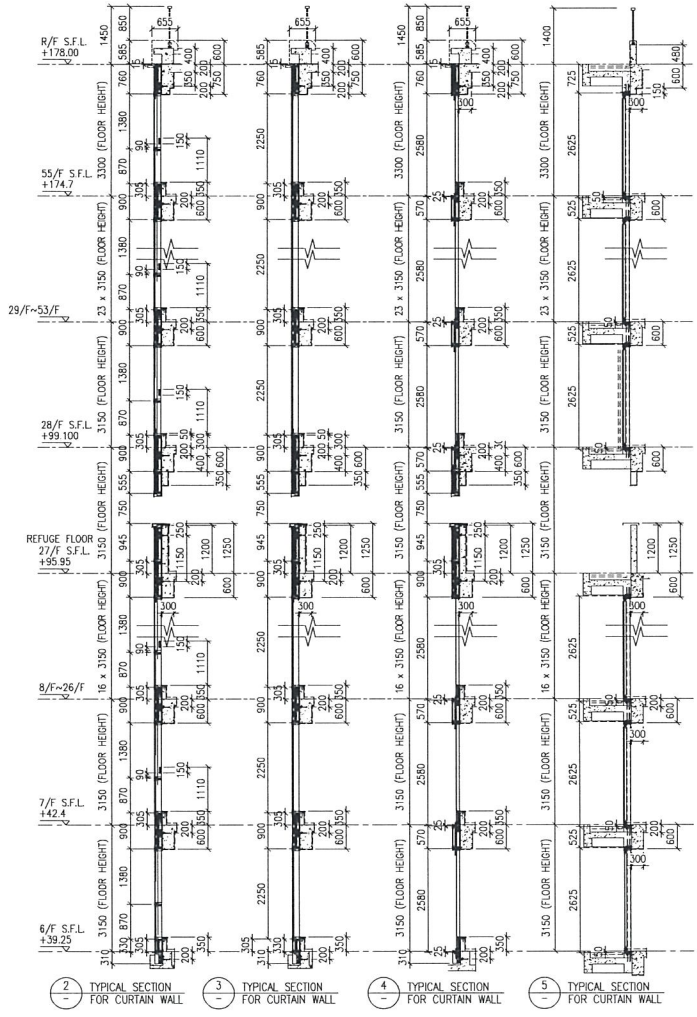
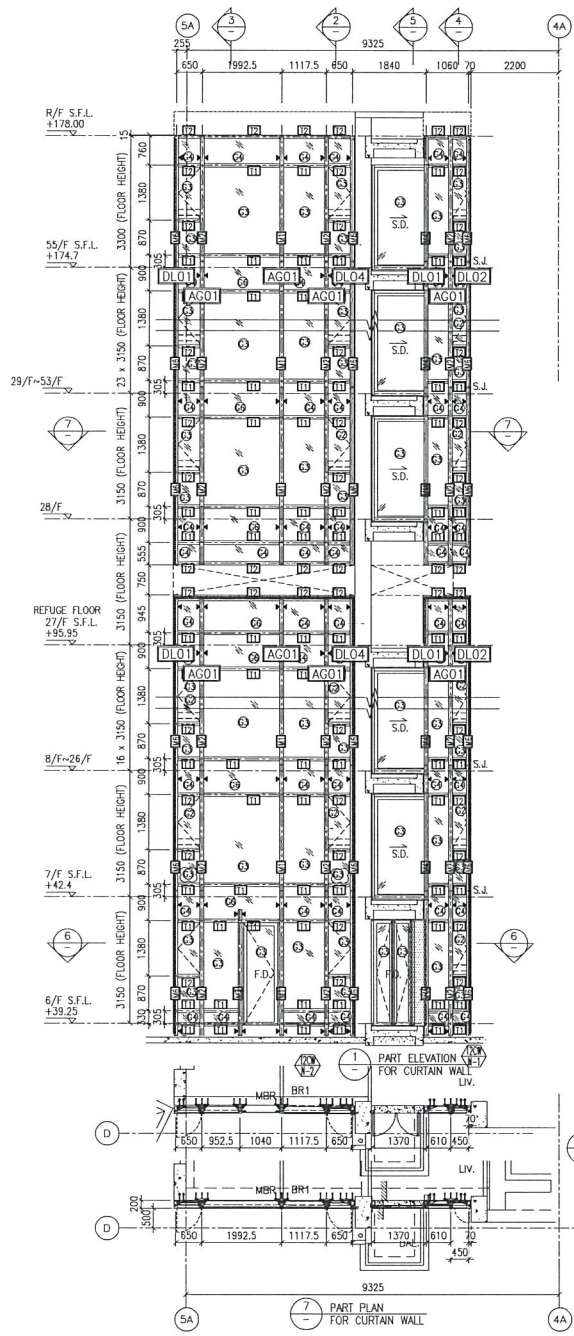

- LEGEND:**
- 10 mm THK. TEMPERED BLUE GLASS (OUTER) + 9 mm AIR SPACE + 10 mm THK. TEMPERED GLASS (INNER)
 - 6 mm THK. TEMPERED BLUE GLASS (OUTER) + 9 mm AIR SPACE + 6 mm THK. TEMPERED GLASS (INNER)
 - 10 mm THK. TEMPERED BLUE TINTED GLASS
 - 8 mm THK. HEAT STRENGTHENED BLUE TINTED GLASS (SPANDREL GLASS)
 - 8 mm THK. TEMPERED BLUE TINTED GLASS (SPANDREL GLASS)
 - 10 mm THK. TEMPERED GLASS (INTERNAL PROTECTIVE BARRIER)
 - 3 mm THK. ALUM. CLADDING
 - M.W. - MAINTENANCE WINDOW
 - S.J. - STACK JOINT
 - ALUM. EXTRUSION DIE NO. / - SUPPORT POINT

B.D. REF :

CLIENT : Sino Land Company Limited

ARCHITECT : WONG TUNG & PARTNERS LIMITED ARCHITECTS & PLANNERS

MAIN CONTRACTOR : CR Construction Company Limited

STRUCTURAL ENGINEER : ACOM

FACADE CONSULTANT : ACOM

NOTE :

- ALL DIMENSIONS ARE IN mm.
- ALL ELEVATIONS ARE VIEWED FROM OUTSIDE.
- ALL DIMENSIONS TO BE VERIFIED ON SITE BEFORE FABRICATION.

LEGEND :

- DETAIL MARK NO.
- REFER SHEET NO.

- F.F.L. - FINISHED FLOOR LEVEL
- S.F.L. - STRUCTURAL FLOOR LEVEL
- REVERSED DETAIL

B	12/10/2018	GENERAL REVISED	
A	10/9/2018	GENERAL REVISED	
REV.	DATE	REVISION	BY

JOB NO. : J-837

PROJECT : URA KWUN TONG TOWN CENTRE REDEVELOPMENT (AREA 2 & 3) AT NKIL 6514, KWUN TONG, KWLOON

TITLE : PART ELEVATION OF CURTAIN WALL AT TOWER 2

DATE : 04-JUL-18 SCALE : 1:60 (A1)

DRAWN BY : ASING CHECKED BY : -

MTDI ALUMINUM FABRICATOR LTD.
Units 5-8, Sunray Industrial Centre, 1/F
610 Cha Kwo Ling Road, Kowloon
Tel: 23489211-4 Fax: (852) 27272666

DWG NO. : JB37-CW-2209 REV. : B

2.40

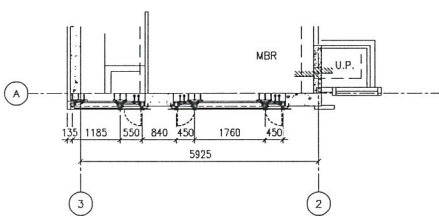
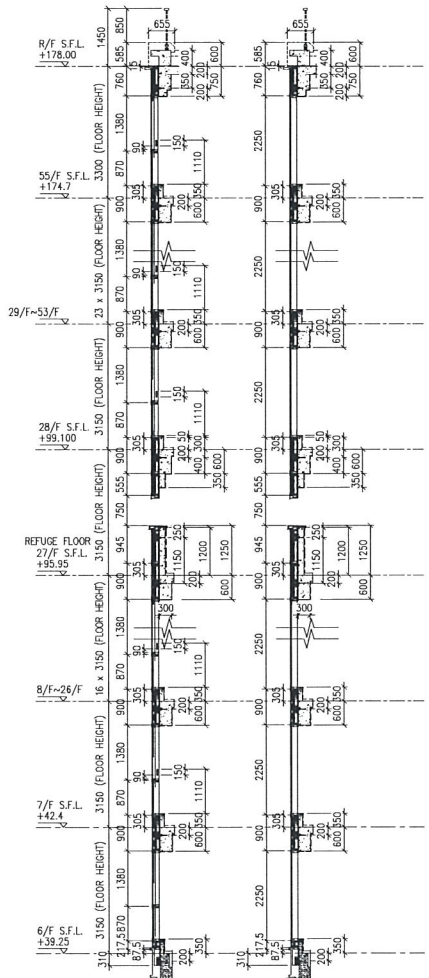
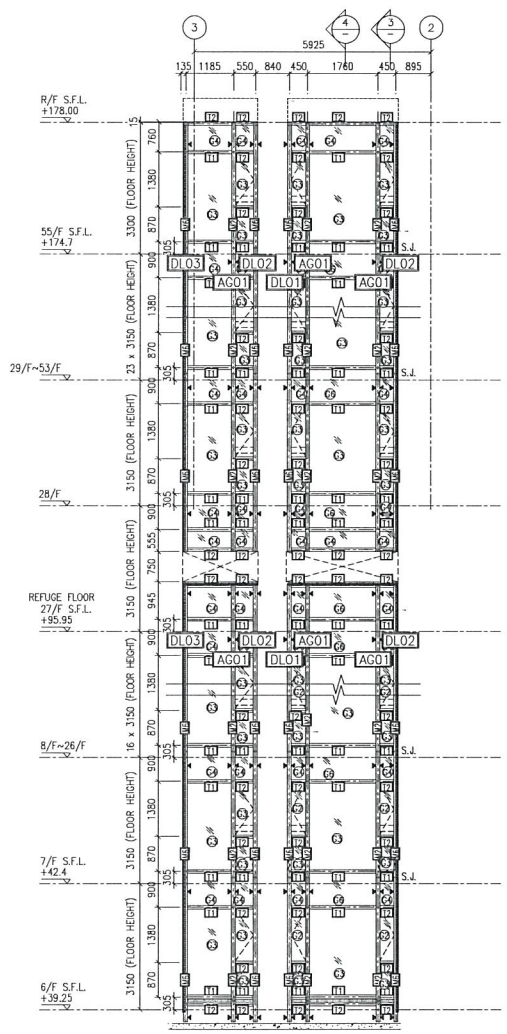

(2) TYPICAL SECTION FOR CURTAIN WALL
(3) TYPICAL SECTION FOR CURTAIN WALL

- LEGEND:**
- 10 mm THK. TEMPERED BLUE GLASS (OUTER) + 9 mm AIR SPACE + 10 mm THK. TEMPERED GLASS (INNER)
 - 6 mm THK. TEMPERED BLUE GLASS (OUTER) + 9 mm AIR SPACE + 6 mm THK. TEMPERED GLASS (INNER)
 - 10 mm THK. TEMPERED BLUE TINTED GLASS
 - 8 mm THK. HEAT STRENGTHENED BLUE TINTED GLASS (SPANDREL GLASS)
 - 8 mm THK. TEMPERED BLUE TINTED GLASS (SPANDREL GLASS)
 - 10 mm THK. TEMPERED GLASS (INTERNAL PROTECTIVE BARRIER)
 - 3 mm THK. ALUM. CLADDING
 - M.W. - MAINTENANCE WINDOW
 - S.J. - STACK JOINT
 - ALUM. EXTRUSION DIE NO.
 - SUPPORT POINT

B.D. REF :

CLIENT :
信和置業有限公司
Sino Land Company Limited

ARCHITECT :
WONG TUNG & PARTNERS LIMITED
ARCHITECTS & PLANNERS
WT

MAIN CONTRACTOR :
CR Construction Company Limited

STRUCTURAL ENGINEER :
ACOM

FACADE CONSULTANT:
ACOM

NOTE:
1. ALL DIMENSIONS ARE IN mm.
2. ALL ELEVATIONS ARE VIEWED FROM OUTSIDE.
3. ALL DIMENSIONS TO BE VERIFIED ON SITE BEFORE FABRICATION.

LEGEND:
 - DETAIL MARK NO.
 - REFER SHEET NO.
1. F.F.L. -- FINISHED FLOOR LEVEL
2. S.F.L. -- STRUCTURAL FLOOR LEVEL
3. (M) -- REVERSED DETAIL

B	12/10/2018	GENERAL REWSED	
A	10/9/2018	GENERAL REWSED	
REV	DATE	REWSED	BY

JOB NO. : J-B37
PROJECT :
URA KWUN TONG TOWN CENTRE
REDEVELOPMENT (AREA 2 & 3) AT
NKIL 6514, KWUN TONG, KWLOON

TITLE :
PART ELEVATION
OF CURTAIN WALL
AT TOWER 2

DATE : 04-JUL-18 SCALE : 1:60 (A1)

DRAWN BY : ASING CHECKED BY : -

英特鋁質有限公司
MIDI ALUMINIUM FABRICATOR LTD.
Units 5-8, Sunny Industrial Centre, 1/F
610 Cha Kwo Ling Road, Kowloon
Tel: 23489211-4 Fax: (852) 2727666

DWG NO. : J837-CW-2210 REV. : B

P41

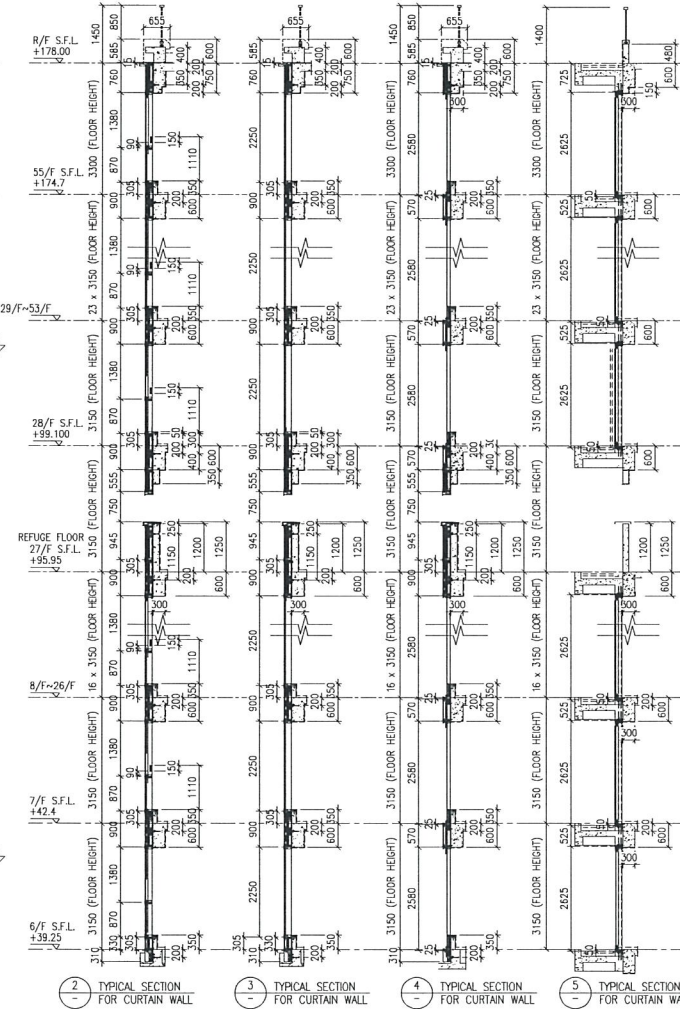
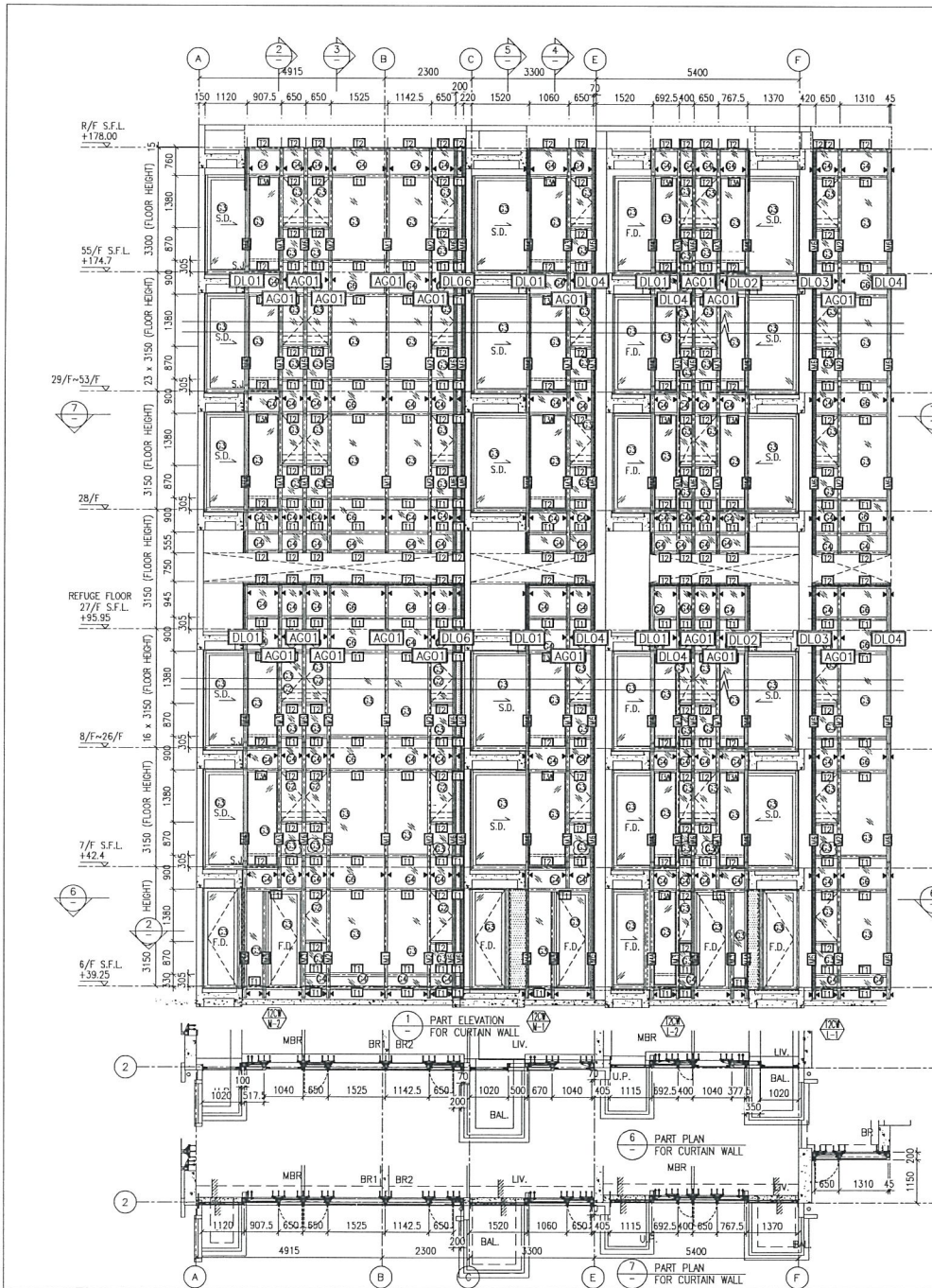

- LEGEND:**
- 10 mm THK. TEMPERED BLUE GLASS (OUTER) + 9 mm AIR SPACE + 10 mm THK. TEMPERED GLASS (INNER)
 - 6 mm THK. TEMPERED BLUE GLASS (OUTER) + 9 mm AIR SPACE + 6 mm THK. TEMPERED GLASS (INNER)
 - 10 mm THK. TEMPERED BLUE TINTED GLASS
 - 8 mm THK. HEAT STRENGTHENED BLUE TINTED GLASS (SPANDREL GLASS)
 - 8 mm THK. TEMPERED BLUE TINTED GLASS (SPANDREL GLASS)
 - 10 mm THK. TEMPERED GLASS (INTERNAL PROTECTIVE BARRIER)
 - 3 mm THK. ALUM. CLADDING
 - M.W. - MAINTENANCE WINDOW
 - S.J. - STACK JOINT
 - ALU01 - ALUM. EXTRUSION DIE NO.
 - SUPPORT POINT

B.D. REF :

CLIENT : **新和置業有限公司**
Sino Land Company Limited

ARCHITECT : **WONG TUNG & PARTNERS LIMITED**
ARCHITECTS & PLANNERS

MAIN CONTRACTOR : **CR Construction Company Limited**

STRUCTURAL ENGINEER : **AECOM**

FACADE CONSULTANT : **AECOM**

NOTE:

- ALL DIMENSIONS ARE IN mm.
- ALL ELEVATIONS ARE VIEWED FROM OUTSIDE.
- ALL DIMENSIONS TO BE VERIFIED ON SITE BEFORE FABRICATION.

LEGEND:

- X1 - DETAIL MARK NO.
- X001 - REFER SHEET NO.

- F.F.L. --- FINISHED FLOOR LEVEL
- S.F.L. --- STRUCTURAL FLOOR LEVEL
- (P) --- REVERSED DETAIL

B	12/10/2018	GENERAL REWISED
A	10/9/2018	GENERAL REWISED
REV	DATE	REWISED BY

JOB NO. : J-837

PROJECT : URA KWUN TONG TOWN CENTRE REDEVELOPMENT (AREA 2 & 3) AT NKIL 6514, KWUN TONG, KWLOON

TITLE : PART ELEVATION OF CURTAIN WALL AT TOWER 2

DATE : 04-JUL-18	SCALE : 1:60 (A1)
DRAWN BY : ASING	CHECKED BY : -

英特鋁質有限公司
MIDI ALUMINIUM FABRICATOR LTD.
Units E-8, Sunny Industrial Centre, 1/F
610 Cho Kwo Ling Road, Kwloon
Tel:23489211-4 Fax:(852)2727666

DWG NO. : J837-CW-2211 REV. : B

p.42

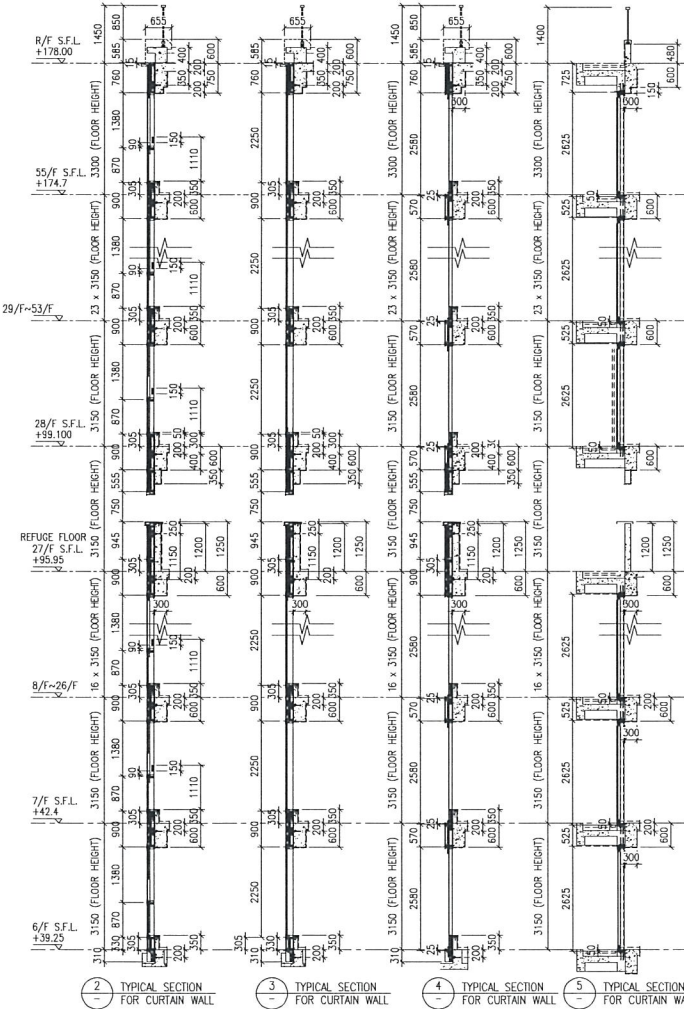
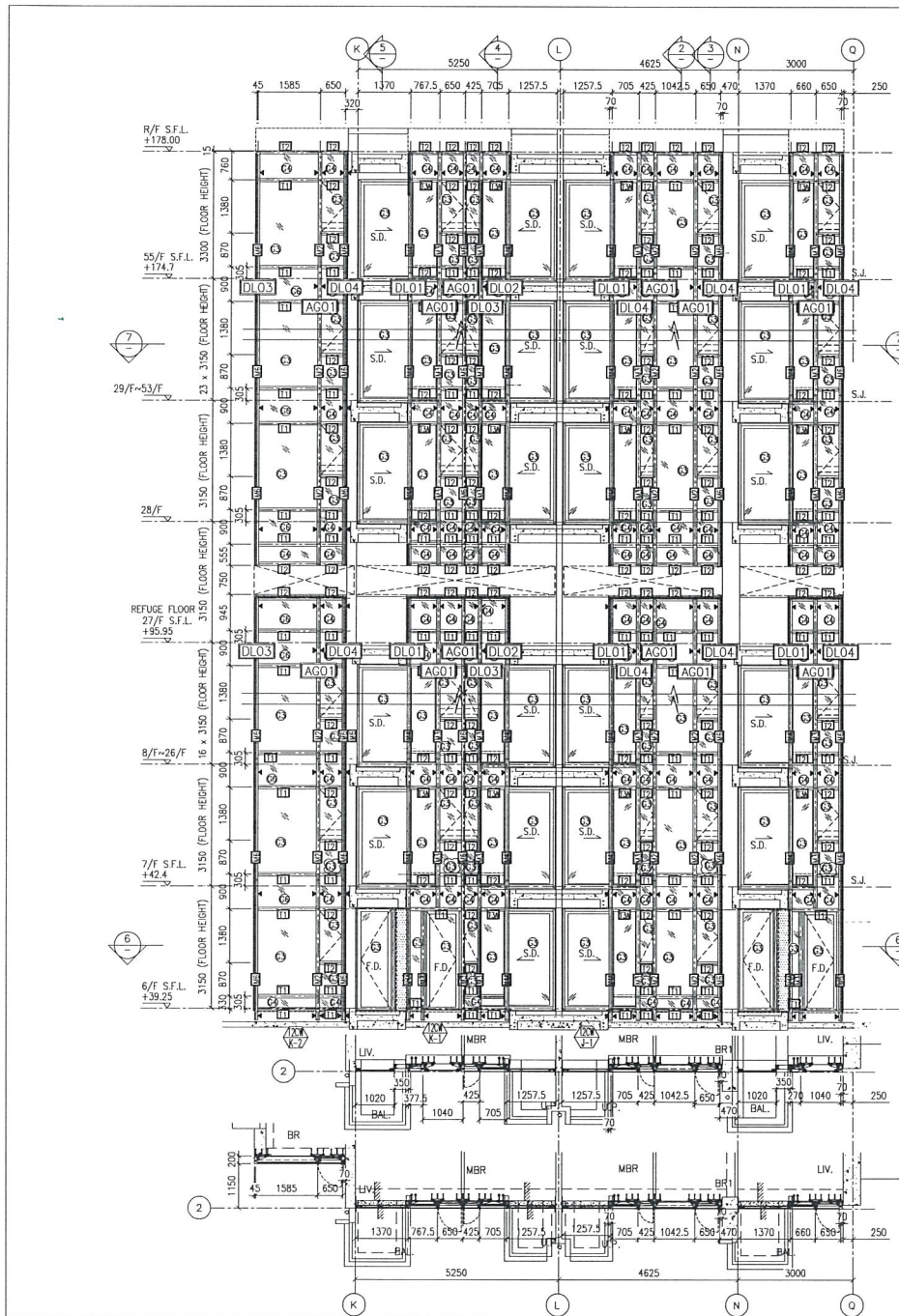

- LEGEND:**
- 10 mm THK. TEMPERED BLUE GLASS (OUTER) + 9 mm AIR SPACE + 10 mm THK. TEMPERED GLASS (INNER)
 - 6 mm THK. TEMPERED BLUE GLASS (OUTER) + 9 mm AIR SPACE + 6 mm THK. TEMPERED GLASS (INNER)
 - 10 mm THK. TEMPERED BLUE TINTED GLASS
 - 8 mm THK. HEAT STRENGTHENED BLUE TINTED GLASS (SPANDREL GLASS)
 - 8 mm THK. TEMPERED BLUE TINTED GLASS (SPANDREL GLASS)
 - 10 mm THK. TEMPERED GLASS (INTERNAL PROTECTIVE BARRIER)
 - 3 mm THK. ALUM. CLADDING
 - M.W. - MAINTENANCE WINDOW
 - S.J. - STACK JOINT
 - AL01 - ALUM. EXTRUSION DIE NO.
 - ▲ - SUPPORT POINT

B.D. REF :

CLIENT : Sino Land Company Limited

ARCHITECT : WONG TUNG & PARTNERS LIMITED ARCHITECTS & PLANNERS

MAIN CONTRACTOR : CR Construction Company Limited

STRUCTURAL ENGINEER : ACOM

FAÇADE CONSULTANT : ACOM

NOTE:

- ALL DIMENSIONS ARE IN mm.
- ALL ELEVATIONS ARE VIEWED FROM OUTSIDE.
- ALL DIMENSIONS TO BE VERIFIED ON SITE BEFORE FABRICATION.

LEGEND:

- DETAIL MARK NO.
- REFER SHEET NO.
- 1. F.F.L. — FINISHED FLOOR LEVEL
- 2. S.F.L. — STRUCTURAL FLOOR LEVEL
- 3. (R) — REVERSED DETAIL

B	12/10/2018	GENERAL REVISED	
ML	10/9/2018	GENERAL REVISED	
	DATE	REVISION	BY

JOB NO. : J-837

PROJECT : URA KWUN TONG TOWN CENTRE REDEVELOPMENT (AREA 2 & 3) AT NKIL 6514, KWUN TONG, KWLOON

TITLE : PART ELEVATION OF CURTAIN WALL AT TOWER 2

DATE : 04-JUL-18 SCALE : 1:60 (A1)

DRAWN BY : ASING CHECKED BY : —

美特鋁質有限公司
 MIDI ALUMINUM FABRICATOR LTD.
 Units 5-8, Sunny Industrial Centre, 1/F
 610 Cha Kwo Ling Road, Kowloon
 Tel: 23489211-4 Fax: (852) 2727666

DWG NO. : JB37-CW-2212 REV. : B

17-43

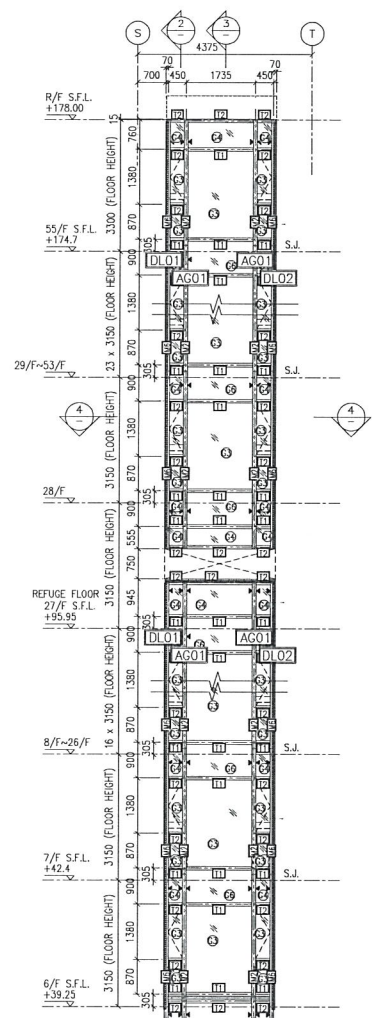

1 PART ELEVATION FOR CURTAIN WALL

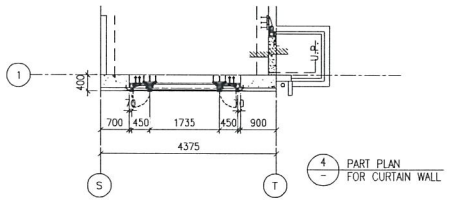

4 PART PLAN FOR CURTAIN WALL

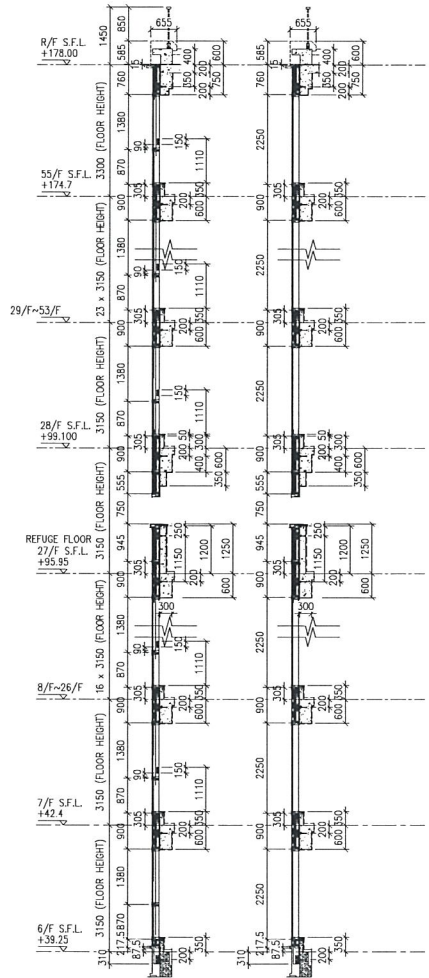

2 TYPICAL SECTION FOR CURTAIN WALL

3 TYPICAL SECTION FOR CURTAIN WALL

- LEGEND:
- 10 mm THK. TEMPERED BLUE GLASS (OUTER) + 9 mm AIR SPACE + 10 mm THK. TEMPERED GLASS (INNER)
 - 6 mm THK. TEMPERED BLUE GLASS (OUTER) + 9 mm AIR SPACE + 6 mm THK. TEMPERED GLASS (INNER)
 - 10 mm THK. TEMPERED BLUE TINTED GLASS
 - 8 mm THK. HEAT STRENGTHENED BLUE TINTED GLASS (SPANDREL GLASS)
 - 8 mm THK. TEMPERED BLUE TINTED GLASS (SPANDREL GLASS)
 - 10 mm THK. TEMPERED GLASS (INTERNAL PROTECTIVE BARRIER)
 - 3 mm THK. ALUM. CLADDING
 - MAINTENANCE WINDOW
 - S.J. - STACK JOINT
 - ALUM. EXTRUSION DIE NO.
 - SUPPORT POINT

B.D. REF :

CLIENT : Sino Land Company Limited

ARCHITECT : WONG TUNG & PARTNERS LIMITED ARCHITECTS & PLANNERS

MAIN CONTRACTOR : CR Construction Company Limited

STRUCTURAL ENGINEER : ACOM

FACADE CONSULTANT : ACOM

NOTE :

- ALL DIMENSIONS ARE IN mm.
- ALL ELEVATIONS ARE VIEWED FROM OUTSIDE.
- ALL DIMENSIONS TO BE VERIFIED ON SITE BEFORE FABRICATION.

LEGEND :

- DETAIL MARK NO.
 - REFER SHEET NO.

1. F.F.L. - FINISHED FLOOR LEVEL
 2. S.F.L. - STRUCTURAL FLOOR LEVEL
 3. (R) - REVERSED DETAIL

B	12/10/2018	GENERAL	REVISED	
A	10/9/2018	GENERAL	REVISED	
NO.	DATE	REVISION		BY

JOB NO. : J-837

PROJECT : URA KWUN TONG TOWN CENTRE REDEVELOPMENT (AREA 2 & 3) AT NKIL 6514, KWUN TONG, KWLOON

TITLE : PART ELEVATION OF CURTAIN WALL AT TOWER 2

DATE : 04-JUL-18 SCALE : 1:60 (A1)

DRAWN BY : ASING CHECKED BY : -

美特鋁質有限公司
 MIDI ALUMINIUM FABRICATOR LTD.
 Units 6-8, Sunny Industrial Centre, 1/F
 610 Cho Kwo Ling Road, Kwai Tsan
 Tel:23489211-4 Fax:(852)2727666

DWG NO. : J837-CW-2213 REV. : B

1244

B.D. REF :

CLIENT :
 信和置業有限公司
 Sino Land Company Limited

ARCHITECT :
 WONG TUNG & PARTNERS LIMITED
 ARCHITECTS & PLANNERS

MAIN CONTRACTOR :
 CR Construction Company Limited

STRUCTURAL ENGINEER :
 ACOM

FAÇADE CONSULTANT :
 ACOM

NOTE:
 1. ALL DIMENSIONS ARE IN mm.
 2. ALL ELEVATIONS ARE VIEWED FROM OUTSIDE.
 3. ALL DIMENSIONS TO BE VERIFIED ON SITE BEFORE FABRICATION.

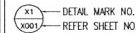
LEGEND:
 (X1) - DETAIL MARK NO.
 (X000) - REFER SHEET NO.
 1. F.F.L. - FINISHED FLOOR LEVEL
 2. S.F.L. - STRUCTURAL FLOOR LEVEL
 3. (R) - REVERSED DETAIL

A	10/9/2018	GENERAL REVISED	BY
REV	DATE	REVISION	

JOB NO. : J-837
 PROJECT : URA KWUN TONG TOWN CENTRE REDEVELOPMENT (AREA 2 & 3) AT NKIL 6514, KWUN TONG, KWLOON

TITLE : PART ELEVATION OF CURTAIN WALL AT TOWER 3









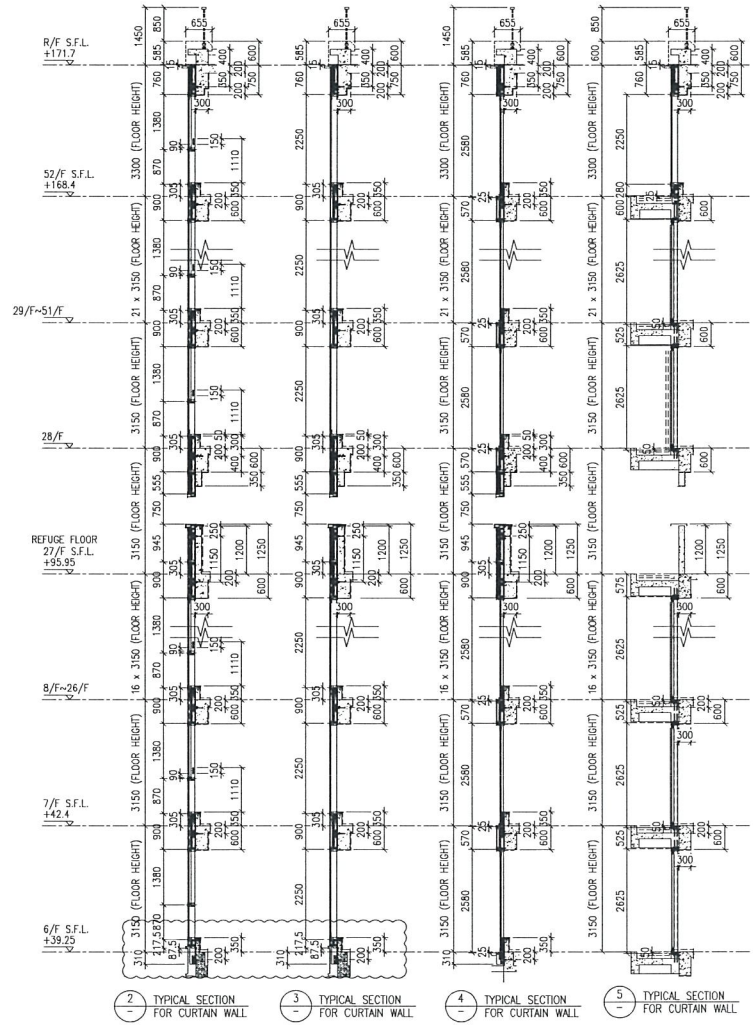
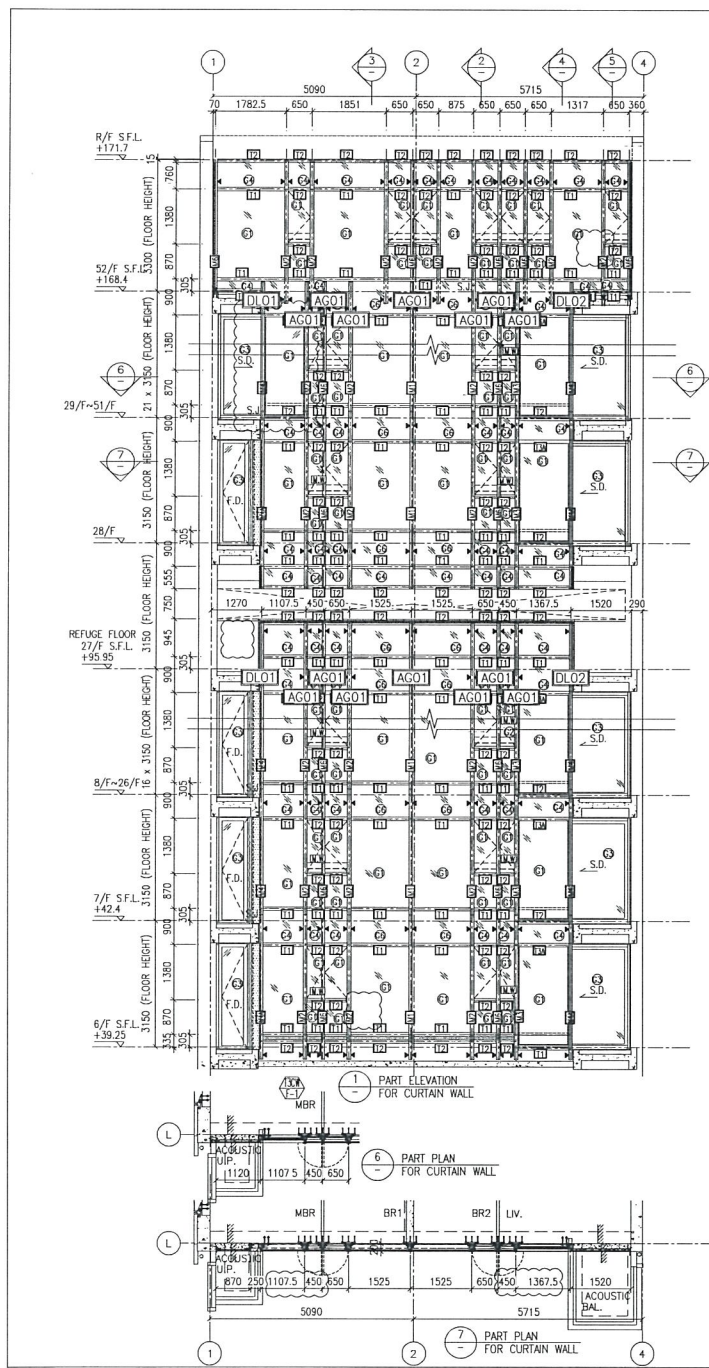

DATE : 04-JUL-18 SCALE : 1:60 (A1)

DRAWN BY : ASING CHECKED BY : -

 美特鋁質有限公司
 MIDI ALUMINUM FABRICATOR LTD.
 Units 5-8, Sunray Industrial Centre, 1/F
 610 Cha Kwo Ling Road, Kwloon
 Tel:23489211-4 Fax:(852)2727666

DWG NO. : JB37-CW-2301 REV. : A



- LEGEND:
-  1 - 10 mm THK. TEMPERED BLUE GLASS (OUTER) + 9 mm AIR SPACE + 10 mm THK. TEMPERED GLASS (INNER)
 -  2 - 6 mm THK. TEMPERED BLUE GLASS (OUTER) + 9 mm AIR SPACE + 6 mm THK. TEMPERED GLASS (INNER)
 -  3 - 10 mm THK. TEMPERED BLUE TINTED GLASS
 -  4 - 8 mm THK. HEAT STRENGTHENED BLUE TINTED GLASS (SPANDREL GLASS)
 -  5 - 8 mm THK. TEMPERED BLUE TINTED GLASS (SPANDREL GLASS)
 -  6 - 10 mm THK. TEMPERED GLASS (INTERNAL PROTECTIVE BARRIER)
 -  7 - 3 mm THK. ALUM. CLADDING
 -  8 - M.W. - MAINTENANCE WINDOW
 -  9 - S.J. - STACK JOINT
 -  10 - ACO1 - ALUM. EXTRUSION DIE NO.
 -  11 - SUPPORT POINT

P.45

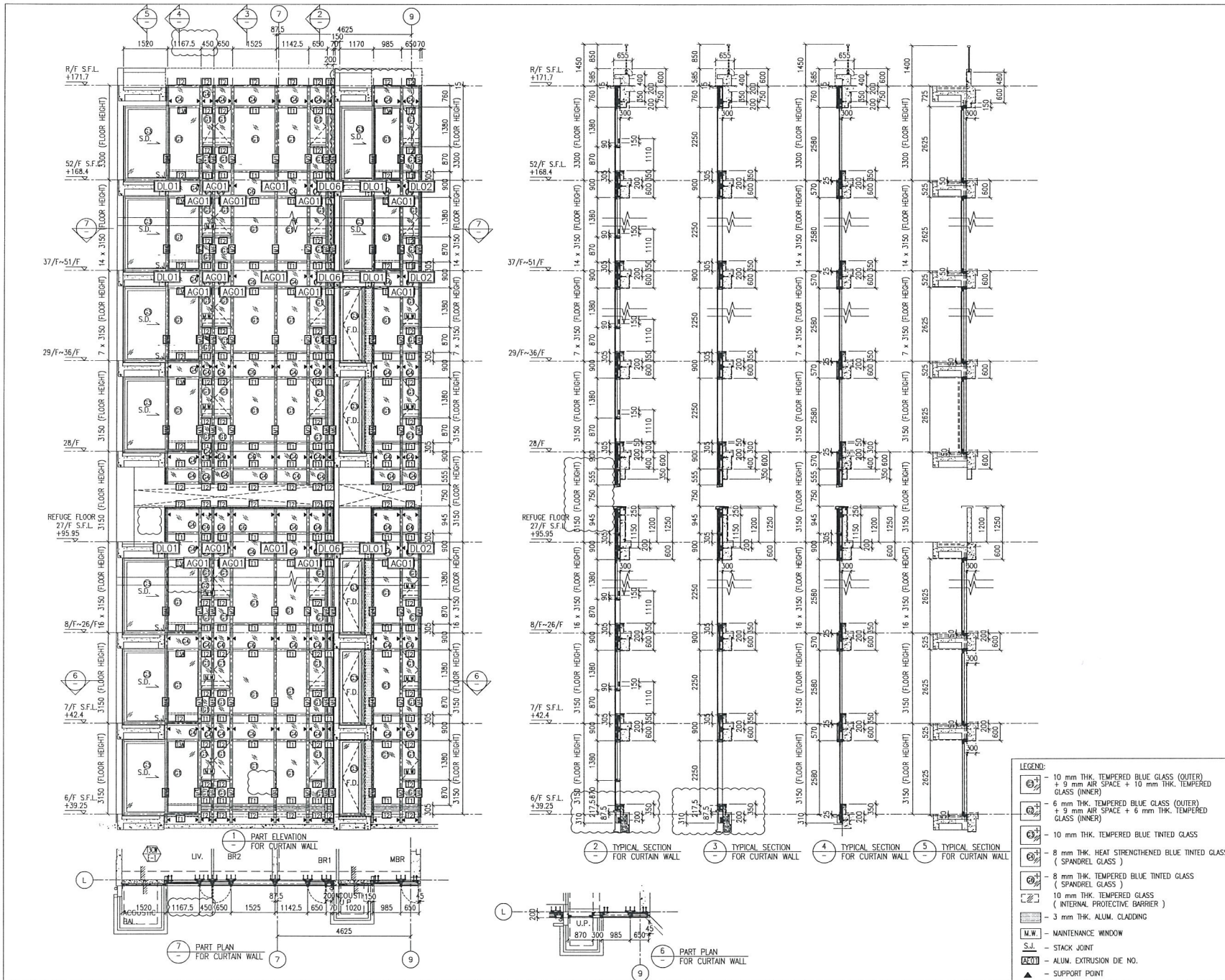

- LEGEND:**
- 10 mm THK. TEMPERED BLUE GLASS (OUTER) + 9 mm AIR SPACE + 10 mm THK. TEMPERED GLASS (INNER)
 - 6 mm THK. TEMPERED BLUE GLASS (OUTER) + 5 mm AIR SPACE + 6 mm THK. TEMPERED GLASS (INNER)
 - 10 mm THK. TEMPERED BLUE TINTED GLASS
 - 8 mm THK. HEAT STRENGTHENED BLUE TINTED GLASS (SPANREL GLASS)
 - 8 mm THK. TEMPERED BLUE TINTED GLASS (SPANREL GLASS)
 - 10 mm THK. TEMPERED GLASS (INTERNAL PROTECTIVE BARRIER)
 - 3 mm THK. ALUM. CLADDING
 - MAINTENANCE WINDOW
 - STACK JOINT
 - ALUM. EXTRUSION DIE NO.
 - SUPPORT POINT

B.D. REF :

CLIENT :
 Sino Land Company Limited

ARCHITECT :
 WONG TUNG & PARTNERS LIMITED ARCHITECTS & PLANNERS

MAIN CONTRACTOR :
 CR Construction Company Limited

STRUCTURAL ENGINEER :
 ACOM

FACADE CONSULTANT :
 ACOM

NOTE :
 1. ALL DIMENSIONS ARE IN mm.
 2. ALL ELEVATIONS ARE VIEWED FROM OUTSIDE.
 3. ALL DIMENSIONS TO BE VERIFIED ON SITE BEFORE FABRICATION.

LEGEND :
 (X1) --- DETAIL MARK NO.
 (X001) --- REFER SHEET NO.

1. F.F.L. --- FINISHED FLOOR LEVEL
 2. S.F.L. --- STRUCTURAL FLOOR LEVEL
 3. (R) --- REVERSED DETAIL

A	10/9/2018	GENERAL REVISED
MS	DATE	REVISION
		BY

JOB NO. : J-837

PROJECT :
 URA KWUN TONG TOWN CENTRE REDEVELOPMENT (AREA 2 & 3) AT NKIL 6514, KWUN TONG, KWLOON

TITLE :
 PART ELEVATION OF CURTAIN WALL AT TOWER 3

DATE : 04-JUL-18 SCALE : 1:60 (A1)

DRAWN BY : ASING CHECKED BY : -

美特鋁質有限公司
 MIDI ALUMINUM FABRICATOR LTD.
 Units 6-8, Sunny Industrial Centre, 1/F
 810 Che Kwo Ling Road, Kwloon
 Tel:23489211-4 Fax:(852)2727666

DWG NO. : JB37-CW-2302 REV. : A

R48

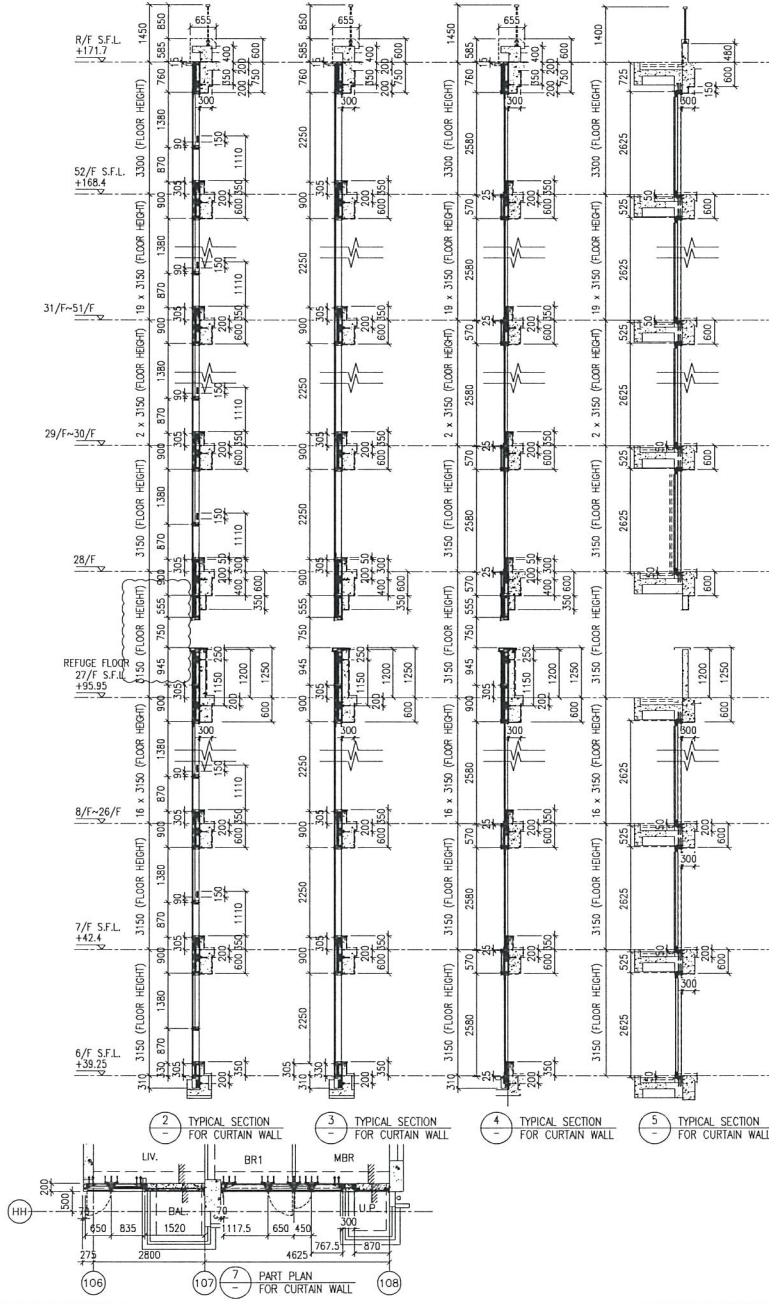
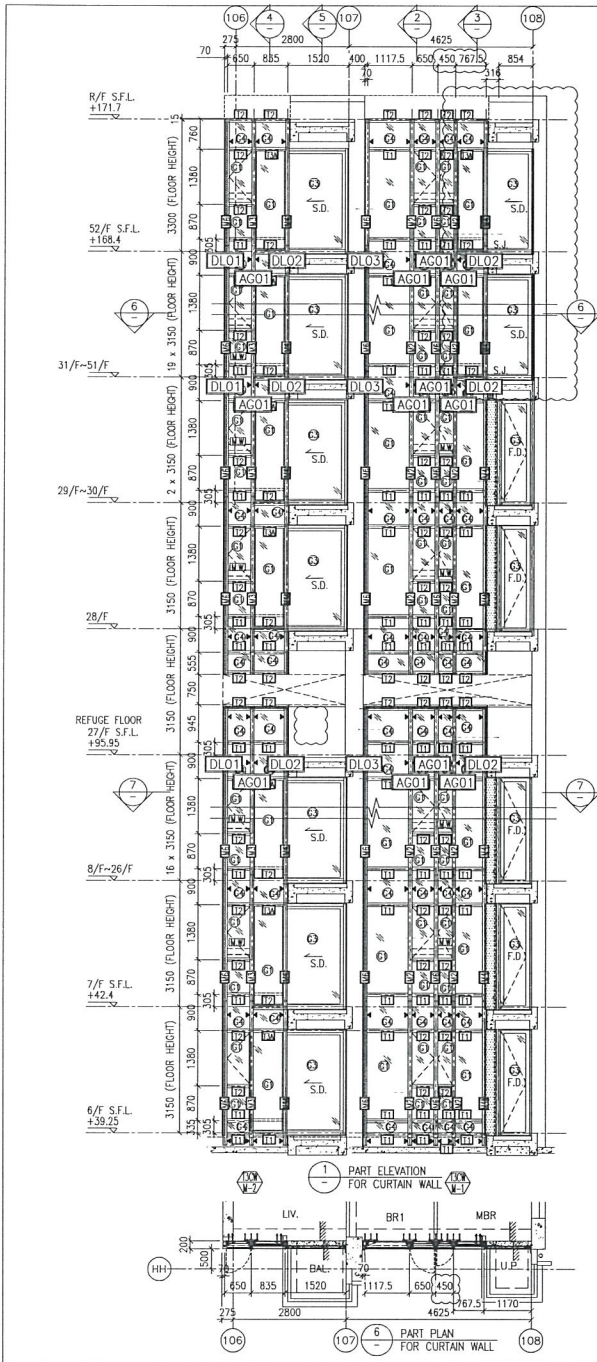

- LEGEND:**
- 10 mm THK. TEMPERED BLUE GLASS (OUTER) + 9 mm AIR SPACE + 10 mm THK. TEMPERED GLASS (INNER)
 - 6 mm THK. TEMPERED BLUE GLASS (OUTER) + 9 mm AIR SPACE + 6 mm THK. TEMPERED GLASS (INNER)
 - 10 mm THK. TEMPERED BLUE TINTED GLASS
 - 8 mm THK. HEAT STRENGTHENED BLUE TINTED GLASS (SPANDREL GLASS)
 - 8 mm THK. TEMPERED BLUE TINTED GLASS (SPANDREL GLASS)
 - 10 mm THK. TEMPERED GLASS (INTERNAL PROTECTIVE BARRIER)
 - 3 mm THK. ALUM. CLADDING
 - MAINTENANCE WINDOW
 - STACK JOINT
 - ALUM. EXTRUSION DIE NO.
 - SUPPORT POINT

B.D. REF :	
CLIENT : Sino Land Company Limited	
ARCHITECT : WONG TUNG & PARTNERS LIMITED ARCHITECTS & PLANNERS	
MAIN CONTRACTOR : CR Construction Company Limited	
STRUCTURAL ENGINEER : ACOM	
FACADE CONSULTANT: ACOM	
NOTE: 1. ALL DIMENSIONS ARE IN mm. 2. ALL ELEVATIONS ARE VIEWED FROM OUTSIDE. 3. ALL DIMENSIONS TO BE VERIFIED ON SITE BEFORE FABRICATION.	
LEGEND: - DETAIL MARK NO. - REFER SHEET NO.	
1. F.F.L. -- FINISHED FLOOR LEVEL 2. S.F.L. -- STRUCTURAL FLOOR LEVEL 3. (R) -- REVERSED DETAIL	
1A	10/9/2018 GENERAL REVISED
1B	DATE REVISION
JOB NO. : J-B37	
PROJECT : URA KWUN TONG TOWN CENTRE REDEVELOPMENT (AREA 2 & 3) AT NKIL 6514, KWUN TONG, KWLOON	
TITLE : PART ELEVATION OF CURTAIN WALL OF TOWER 3	
DATE : 04-JUL-18	SCALE : 1:60 (A1)
DRAWN BY : ASING	CHECKED BY : -
MIDI ALUMINIUM FABRICATOR LTD. Units E-8, Sunray Industrial Centre, 1/F 610 Cha Kwo Ling Road, Kwunoon Tel:23489211-4 Fax:(852)27272666	
DWG NO. : JB37-CW-2303	REV. : A

297

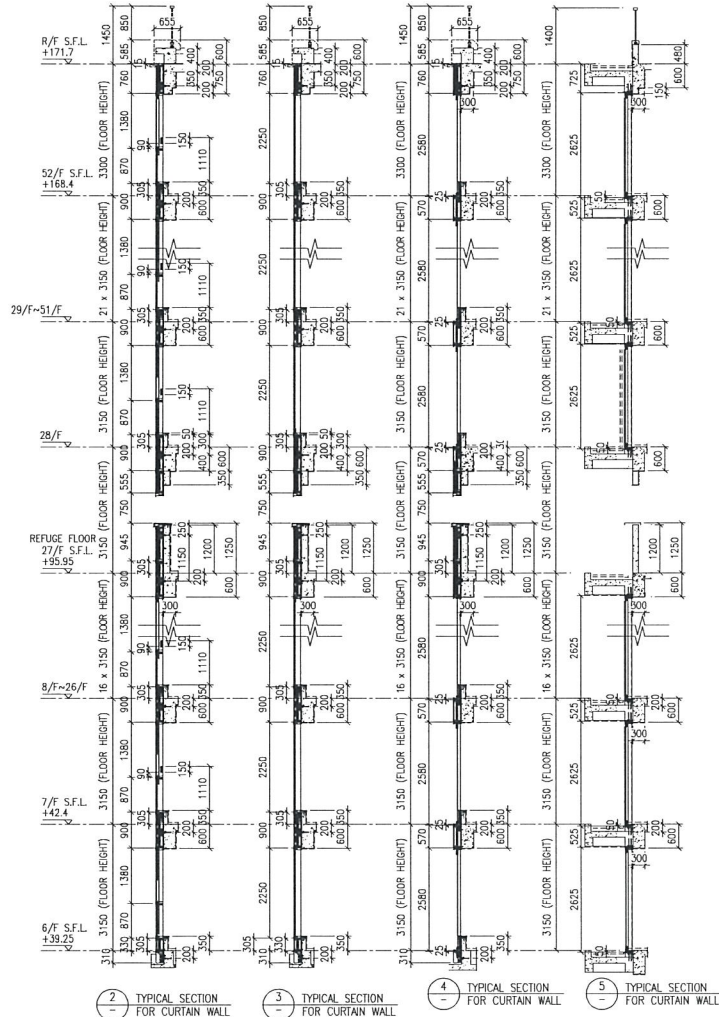
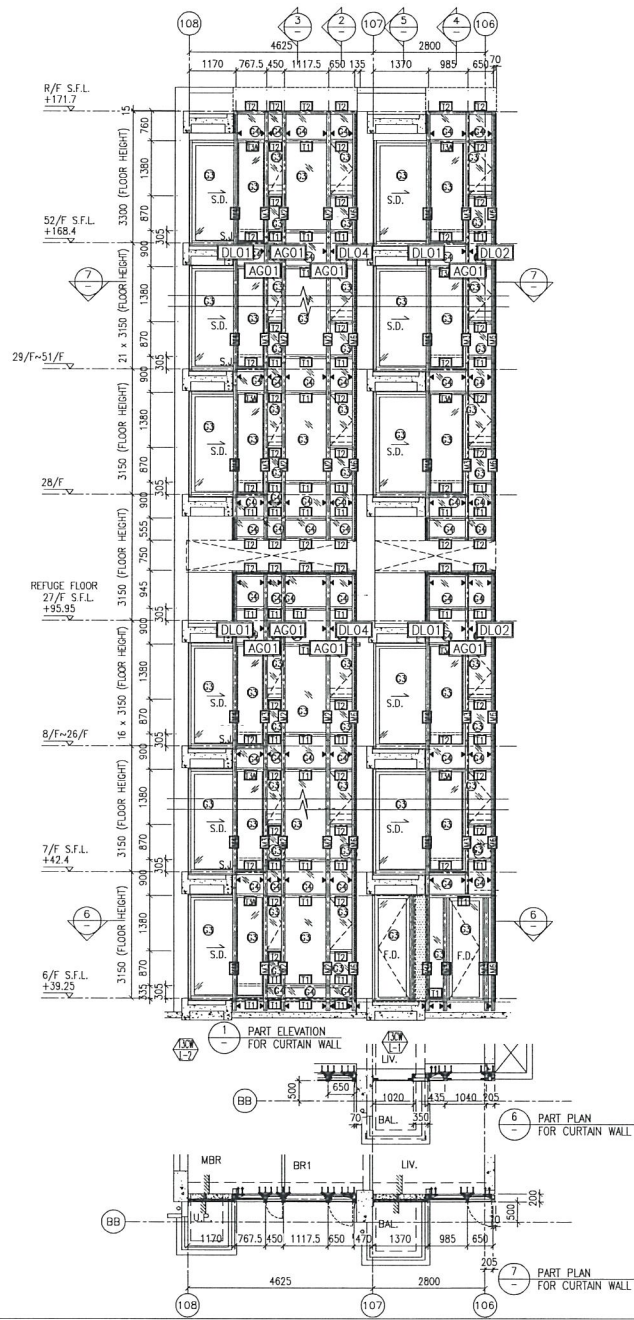

LEGEND:

B.D. REF :

CLIENT :
 Sino Land Company Limited

ARCHITECT :

MAIN CONTRACTOR :

STRUCTURAL ENGINEER :

FAÇADE CONSULTANT :

NOTE:
 1. ALL DIMENSIONS ARE IN mm.
 2. ALL ELEVATIONS ARE VIEWED FROM OUTSIDE.
 3. ALL DIMENSIONS TO BE VERIFIED ON SITE BEFORE FABRICATION.

LEGEND:
 (M) - DETAIL MARK NO.
 (R) - REFER SHEET NO.
 1. F.F.L. -- FINISHED FLOOR LEVEL
 2. S.F.L. -- STRUCTURAL FLOOR LEVEL
 3. (S) -- REVERSED DETAIL

B	12/10/2018	GENERAL REWSED
A	10/9/2018	GENERAL REWSED
NO.	DATE	REVISION

JOB NO. : J-837

PROJECT :
 URA KWUN TONG TOWN CENTRE
 REDEVELOPMENT (AREA 2 & 3) AT
 NKIL 6514, KWUN TONG, KWLOON

TITLE :
 PART ELEVATION OF CURTAIN WALL
 AT TOWER 3

DATE : 04-JUL-18 SCALE : 1:60 (A1)

DRAWN BY : ASING CHECKED BY : -

美特銘質有限公司
 MTDI ALUMINIUM FABRICATOR LTD.
 Units 5-8, Sunray Industrial Centre, 1/F
 610 Cha Kwo Ling Road, Kowloon
 Tel:23489211-4 Fax:(852)2727666

DWG NO. : JB37-CW-2304 REV. : B

P-48

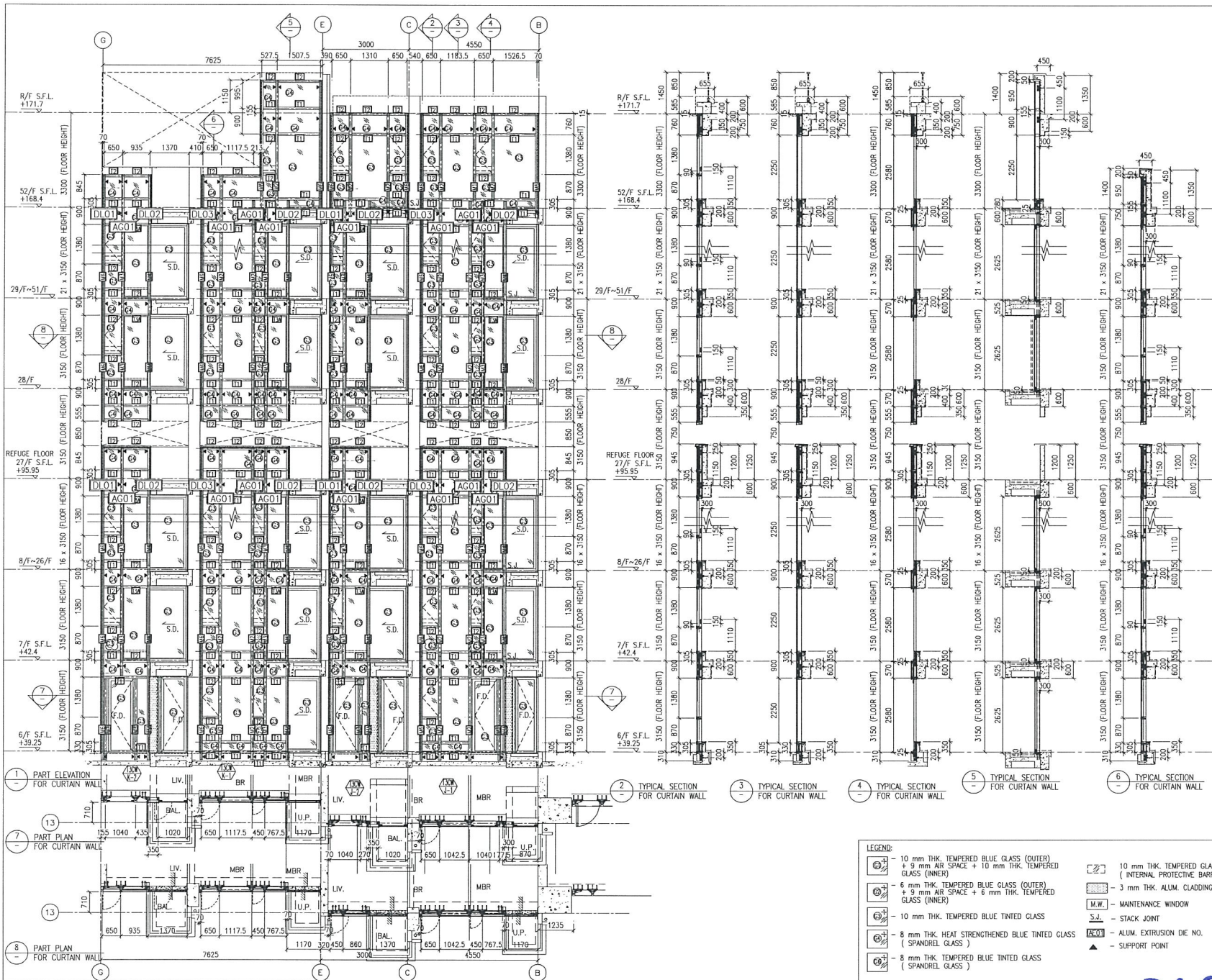

B.D. REF :	
CLIENT : 信和置業有限公司 Sino Land Company Limited	
ARCHITECT : WONG TUNG & PARTNERS LIMITED ARCHITECTS & PLANNERS WT	
MAIN CONTRACTOR : CR Construction Company Limited	
STRUCTURAL ENGINEER : AZCOM	
FACADE CONSULTANT : AZCOM	
NOTE : 1. ALL DIMENSIONS ARE IN mm. 2. ALL ELEVATIONS ARE VIEWED FROM OUTSIDE. 3. ALL DIMENSIONS TO BE VERIFIED ON SITE BEFORE FABRICATION.	
LEGEND : X1 - DETAIL MARK NO. REF - REFER SHEET NO. 1. F.F.L. --- FINISHED FLOOR LEVEL 2. S.F.L. --- STRUCTURAL FLOOR LEVEL 3. (P) --- REVERSED DETAIL	
B	12/10/2018 GENERAL REVISED
A	10/9/2018 GENERAL REVISED
DR	DATE REVISION
JOB NO. : J-837	
PROJECT : URA KWUN TONG TOWN CENTRE REDEVELOPMENT (AREA 2 & 3) AT NKIL 6514, KWUN TONG, KWLOON	
TITLE : PART ELEVATION OF CURTAIN WALL AT TOWER 3	
DATE : 04-JUL-18	SCALE : 1:60 (A1)
DRAWN BY : ASING	CHECKED BY : -
美特鋁質有限公司 MIDI ALUMINIUM FABRICATOR LTD. Units 6-8, Sunny Industrial Centre, 1/F 610 Che Kwo Ling Road, Kwun Tong Tel:23489211-4 Fax:(852)27272666	
DWG NO. : J837-CW-2305	REV. : B

P.49

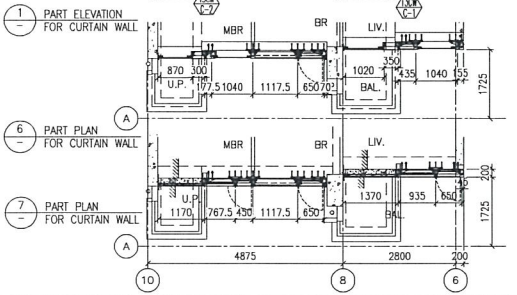
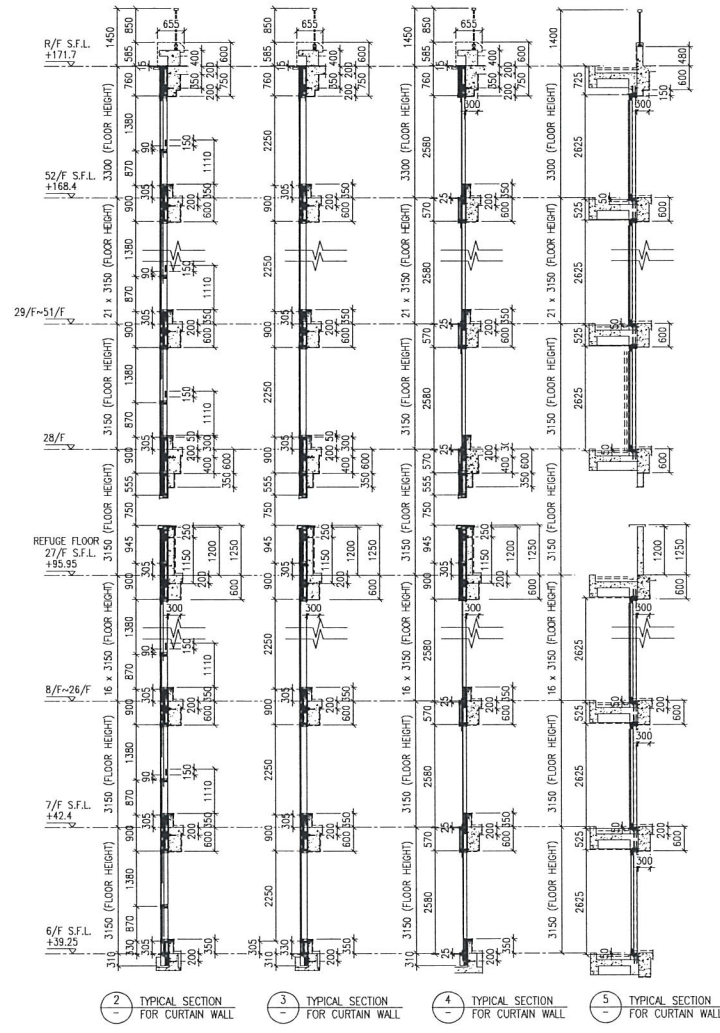
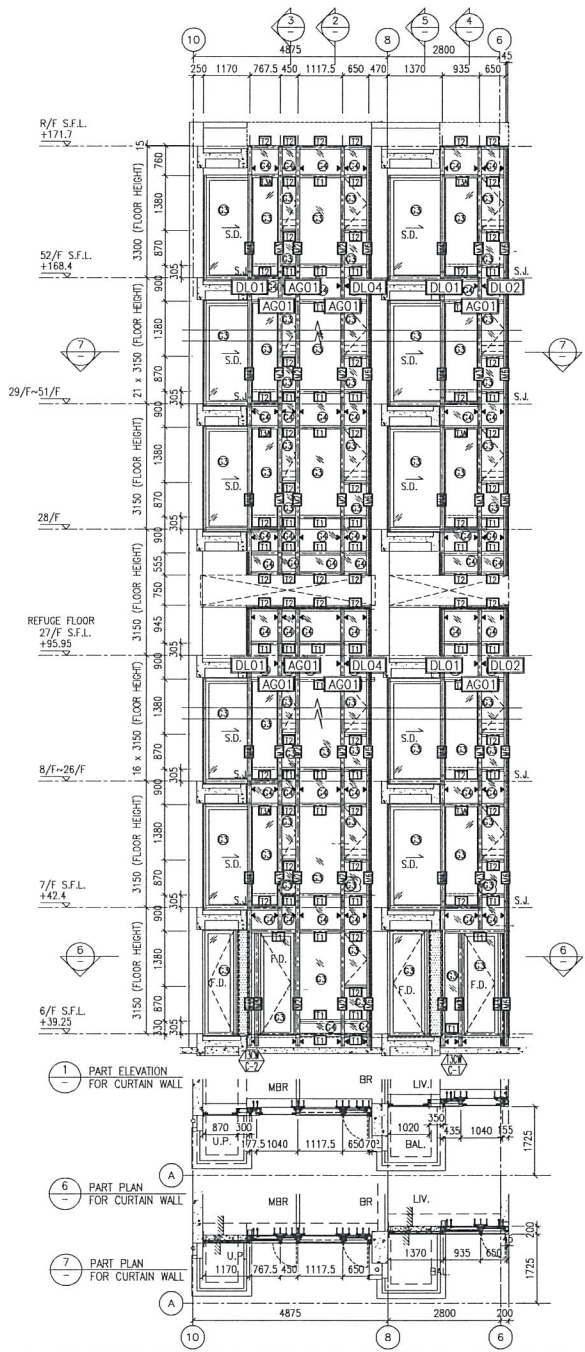

- LEGEND:**
- 10 mm THK. TEMPERED BLUE GLASS (OUTER) + 9 mm AIR SPACE + 10 mm THK. TEMPERED GLASS (INNER)
 - 6 mm THK. TEMPERED BLUE GLASS (OUTER) + 9 mm AIR SPACE + 6 mm THK. TEMPERED GLASS (INNER)
 - 10 mm THK. TEMPERED BLUE TINTED GLASS
 - 8 mm THK. HEAT STRENGTHENED BLUE TINTED GLASS (SPANDREL GLASS)
 - 8 mm THK. TEMPERED BLUE TINTED GLASS (SPANDREL GLASS)
 - 10 mm THK. TEMPERED GLASS (INTERNAL PROTECTIVE BARRIER)
 - 3 mm THK. ALUM. CLADDING
 - M.W. - MAINTENANCE WINDOW
 - S.J. - STACK JOINT
 - AEO1 - ALUM. EXTRUSION DIE NO.
 - ▲ - SUPPORT POINT

B.D. REF :

CLIENT :
 Sino Land Company Limited

ARCHITECT :
 WONG TUNG & PARTNERS LIMITED
 ARCHITECTS & PLANNERS

MAIN CONTRACTOR :
 CR Construction Company Limited

STRUCTURAL ENGINEER :
 ACOM

FAÇADE CONSULTANT :
 ACOM

NOTE :
 1. ALL DIMENSIONS ARE IN mm.
 2. ALL ELEVATIONS ARE VIEWED FROM OUTSIDE.
 3. ALL DIMENSIONS TO BE VERIFIED ON SITE BEFORE FABRICATION.

LEGEND :
 X1 - DETAIL MARK NO.
 X001 - REFER SHEET NO.

1. F.F.L. -- FINISHED FLOOR LEVEL
 3. S.F.L. -- STRUCTURAL FLOOR LEVEL
 3. (P) -- REVERSED DETAIL

B	12/10/2018	GENERAL REVISED
A	10/9/2018	GENERAL REVISED
NO.	DATE	REVISION

JOB NO. : J-837

PROJECT :
 URA KWUN TONG TOWN CENTRE REDEVELOPMENT (AREA 2 & 3) AT NKIL 6514, KWUN TONG, KWLOON

TITLE :
 PART ELEVATION OF CURTAIN WALL AT TOWER 3

DATE : 04-JUL-18 SCALE : 1:60 (A1)

DRAWN BY : ASING CHECKED BY : -

美特鋁質有限公司
 MIDI ALUMINIUM FABRICATOR LTD.
 Units E-8, Sunay Industrial Centre, 1/F
 610 Che Kwo Ling Road, Kwloon
 Tel:23489211-4 Fax:(852)2727666

DWG NO. : J837-CW-2307 REV. : B

P-51

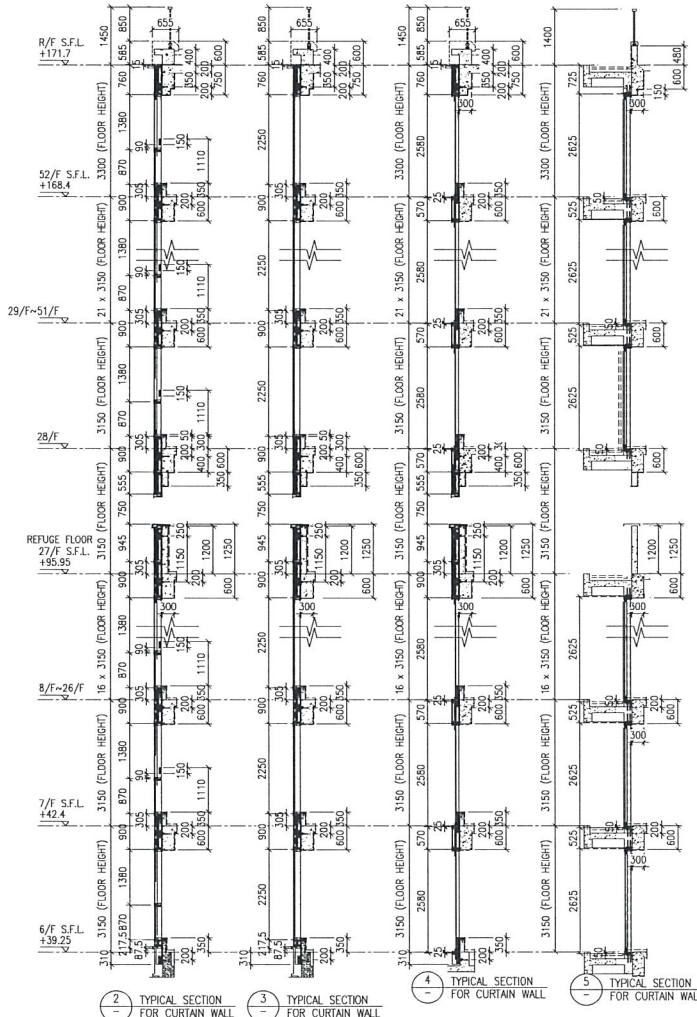
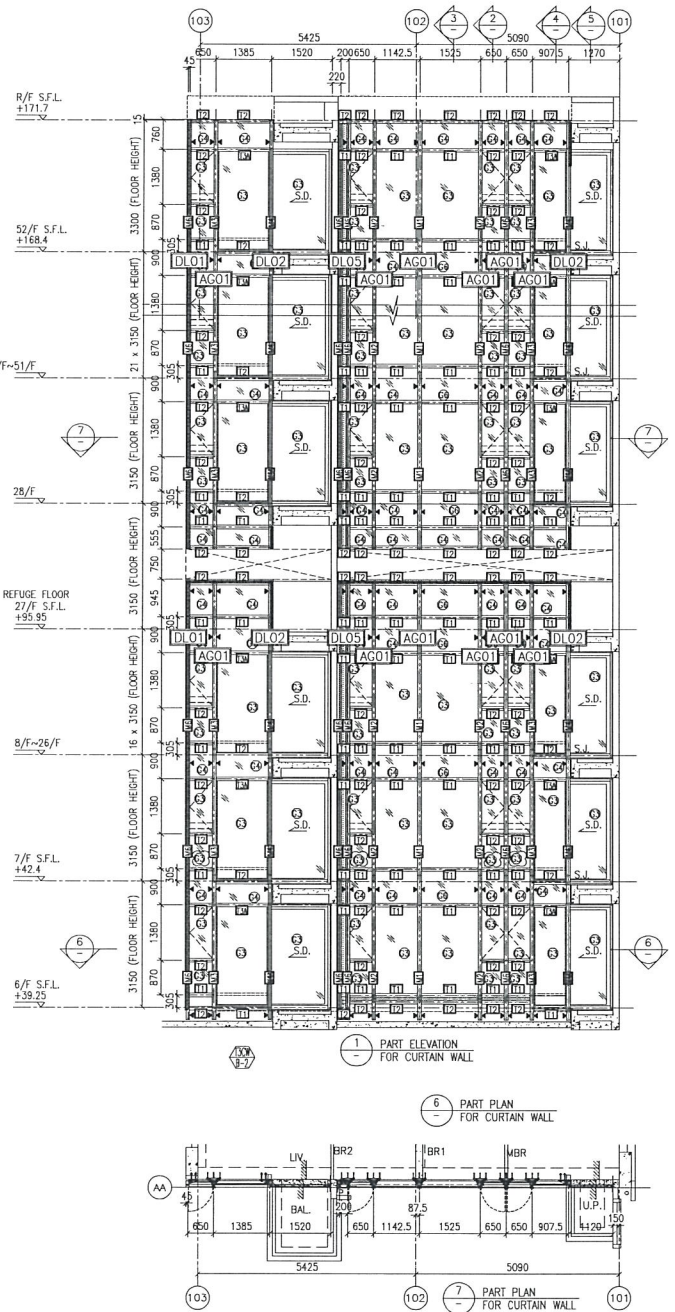

LEGEND:

B.D. REF :	
CLIENT : Sino Land Company Limited	
ARCHITECT : WONG TUNG & PARTNERS LIMITED ARCHITECTS & PLANNERS	
MAIN CONTRACTOR : CR Construction Company Limited	
STRUCTURAL ENGINEER : ACCOM	
FACADE CONSULTANT : ACCOM	
NOTE : 1. ALL DIMENSIONS ARE IN mm. 2. ALL ELEVATIONS ARE VIEWED FROM OUTSIDE. 3. ALL DIMENSIONS TO BE VERIFIED ON SITE BEFORE FABRICATION.	
LEGEND : - DETAIL MARK NO. - REFER SHEET NO. 1. F.F.L. - FINISHED FLOOR LEVEL 2. S.F.L. - STRUCTURAL FLOOR LEVEL 3. (R) - REVERSED DETAIL	
B	12/10/2018 GENERAL REVISED
A	10/9/2018 GENERAL REVISED
REV.	DATE REVISION BY
JOB NO. : J-837	
PROJECT : URA KWUN TONG TOWN CENTRE REDEVELOPMENT (AREA 2 & 3) AT NKIL 6514, KWUN TONG, KWLOON	
TITLE : PART ELEVATION OF CURTAIN WALL AT TOWER 3	
DATE : 04-JUL-18	SCALE : 1:60 (A1)
DRAWN BY : ASING	CHECKED BY : -
美特鋁質有限公司 MTI ALUMINIUM FABRICATOR LTD. Units 6-8, Sunny Industrial Centre, 1/F 610 Cho Kwo Ling Road, Kwloon Tel:23489211-4 Fax:(852)2727666	
DWG NO. : JB37-CW-2308	REV. : B

P.52

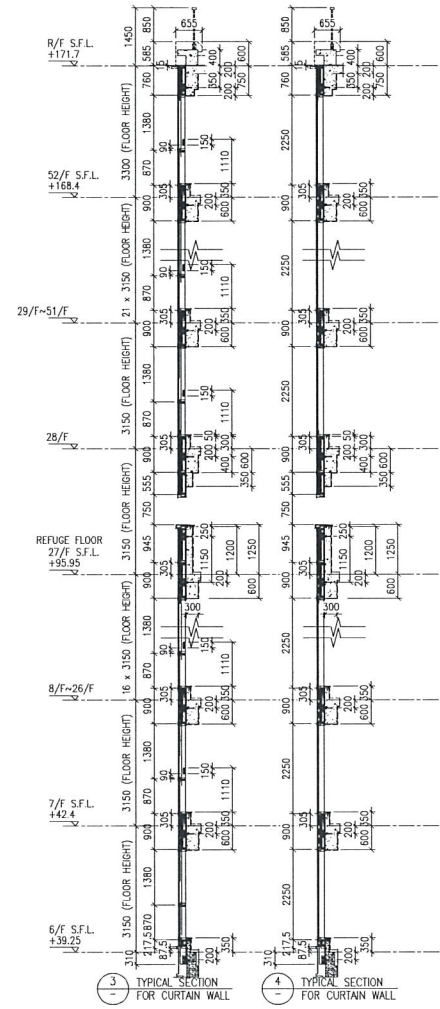
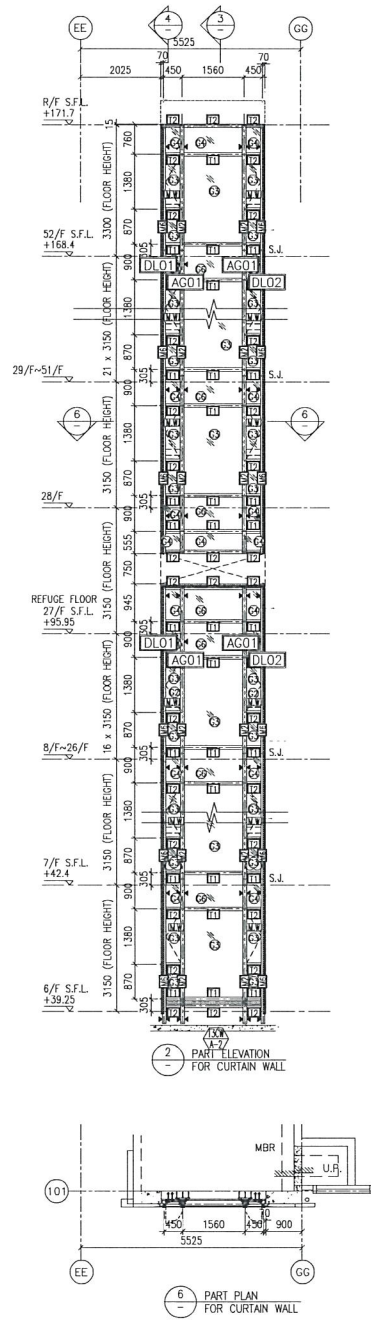
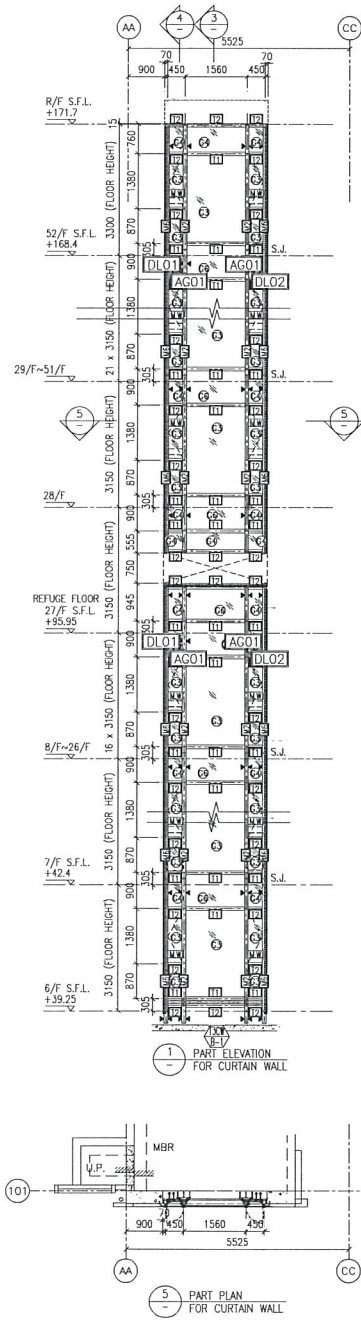

- LEGEND:**
- 10 mm THK. TEMPERED BLUE GLASS (OUTER) + 9 mm AIR SPACE + 10 mm THK. TEMPERED GLASS (INNER)
 - 6 mm THK. TEMPERED BLUE GLASS (OUTER) + 9 mm AIR SPACE + 6 mm THK. TEMPERED GLASS (INNER)
 - 10 mm THK. TEMPERED BLUE TINTED GLASS
 - 8 mm THK. HEAT STRENGTHENED BLUE TINTED GLASS (SPANDREL GLASS)
 - 8 mm THK. TEMPERED BLUE TINTED GLASS (SPANDREL GLASS)
 - 10 mm THK. TEMPERED GLASS (INTERNAL PROTECTIVE BARRIER)
 - 3 mm THK. ALUM. CLADDING
 - MAINTENANCE WINDOW
 - STACK JOINT
 - ALUM. EXTRUSION DIE NO.
 - SUPPORT POINT

B.D. REF :

CLIENT : **信和置業有限公司**
Sino Land Company Limited

ARCHITECT : **WONG TUNG & PARTNERS LIMITED**
ARCHITECTS & PLANNERS

MAIN CONTRACTOR : **CR Construction Company Limited**

STRUCTURAL ENGINEER : **A2COM**

FAÇADE CONSULTANT : **A2COM**

NOTE :

- ALL DIMENSIONS ARE IN mm.
- ALL ELEVATIONS ARE VIEWED FROM OUTSIDE.
- ALL DIMENSIONS TO BE VERIFIED ON SITE BEFORE FABRICATION.

LEGEND :

- DETAIL MARK NO.
 - REFER SHEET NO.

- F.F.L. - FINISHED FLOOR LEVEL
- S.F.L. - STRUCTURAL FLOOR LEVEL
- REVERSED DETAIL

B	12/10/2018	GENERAL REVISED	
A	10/9/2018	GENERAL REVISED	
REV	DATE	REVISION	BY

JOB NO. : J-837

PROJECT : URA KWUN TONG TOWN CENTRE REDEVELOPMENT (AREA 2 & 3) AT NKIL 6514, KWUN TONG, KWLOON

TITLE : PART ELEVATION OF CURTAIN WALL AT TOWER 3

DATE : 04-JUL-18 SCALE : 1:60 (A1)

DRAWN BY : ASING CHECKED BY : -

美特銘質有限公司
MIDI ALUMINIUM FABRICATOR LTD.
Units 5-8, Sunray Industrial Centre, 1/F
610 Cha Kwo Ling Road, Kowloon
Tel: 23489211-4 Fax: (852) 27272666

DWG NO. : JB37-CW-2309 REV. : B

P.53

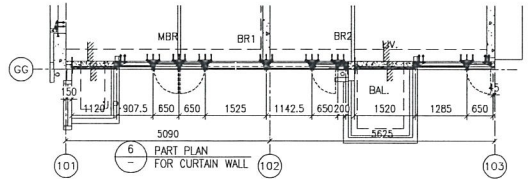
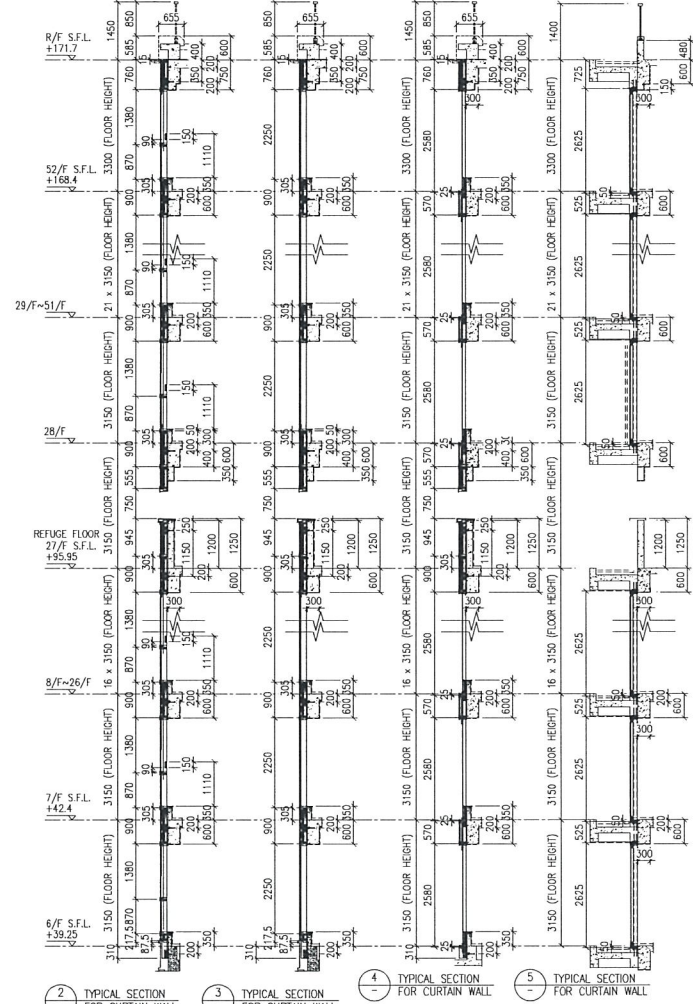
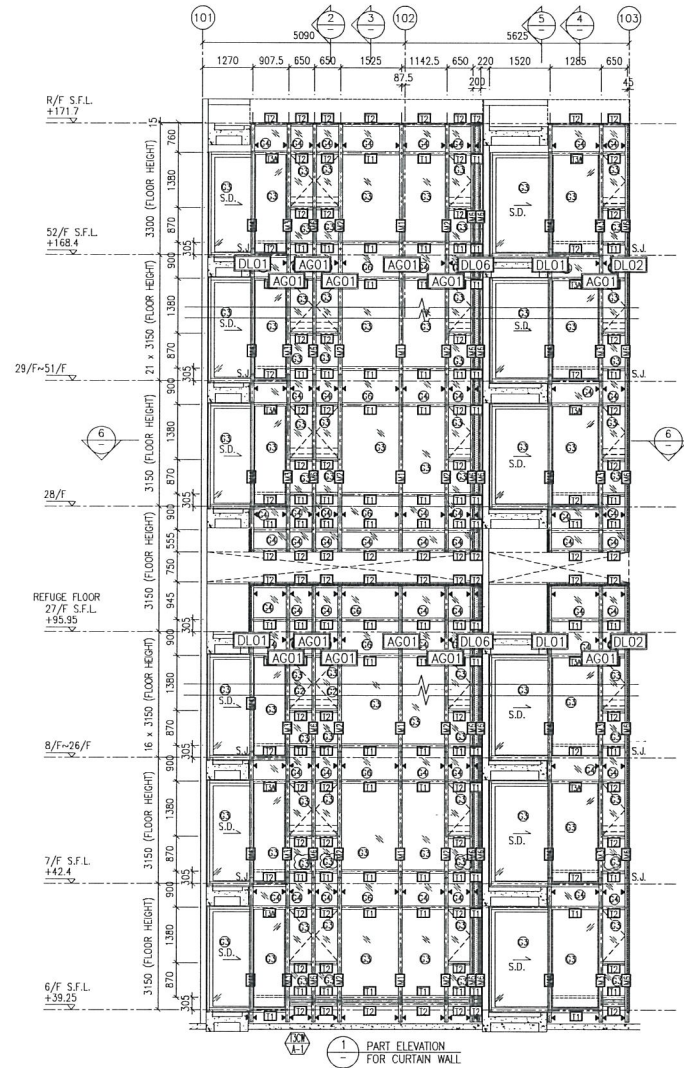

- LEGEND:**
- 10 mm THK. TEMPERED BLUE GLASS (OUTER) + 9 mm AIR SPACE + 10 mm THK. TEMPERED GLASS (INNER)
 - 6 mm THK. TEMPERED BLUE GLASS (OUTER) + 9 mm AIR SPACE + 6 mm THK. TEMPERED GLASS (INNER)
 - 10 mm THK. TEMPERED BLUE TINTED GLASS
 - 8 mm THK. HEAT STRENGTHENED BLUE TINTED GLASS (SPANDREL GLASS)
 - 8 mm THK. TEMPERED BLUE TINTED GLASS (SPANDREL GLASS)
 - 10 mm THK. TEMPERED GLASS (INTERNAL PROTECTIVE BARRIER)
 - 3 mm THK. ALUM. CLADDING
 - M.W. - MAINTENANCE WINDOW
 - S.J. - STACK JOINT
 - A.E.D. - ALUM. EXTRUSION DIE NO.
 - ▲ - SUPPORT POINT

B.D. REF :

CLIENT : 德利置業有限公司 Sino Land Company Limited

ARCHITECT : WONG TUNG & PARTNERS LIMITED ARCHITECTS & PLANNERS

MAIN CONTRACTOR : CR Construction Company Limited

STRUCTURAL ENGINEER : ACOM

FACADE CONSULTANT : ACOM

NOTE:

- ALL DIMENSIONS ARE IN mm.
- ALL ELEVATIONS ARE VIEWED FROM OUTSIDE.
- ALL DIMENSIONS TO BE VERIFIED ON SITE BEFORE FABRICATION.

LEGEND:

- DETAIL MARK NO.
- REFER SHEET NO.

1. F.F.L. - FINISHED FLOOR LEVEL
 2. S.F.L. - STRUCTURAL FLOOR LEVEL
 3. (S) - REVERSED DETAIL

B	12/10/2018	GENERAL REWSED	
A	10/9/2018	GENERAL REWSED	
REV	DATE	REWSED	BY

JOB NO. : J-B37

PROJECT : URA KWUN TONG TOWN CENTRE REDEVELOPMENT (AREA 2 & 3) AT NKIL 6514, KWUN TONG, KWLOON

TITLE : PART ELEVATION OF CURTAIN WALL AT TOWER 3

DATE : 04-JUL-18 SCALE : 1:60 (A1)

DRAWN BY : ASING CHECKED BY : -

美特鋁質有限公司
 MIDT ALUMINIUM FABRICATOR LTD.
 Units 5-8, Sunray Industrial Centre, 1/F
 610 Cha Kwo Ling Road, Kwloon
 Tel:23489211-4 Fax:(852)2727666

DWG NO. : JB37-CW-2310 REV. : B

P-54

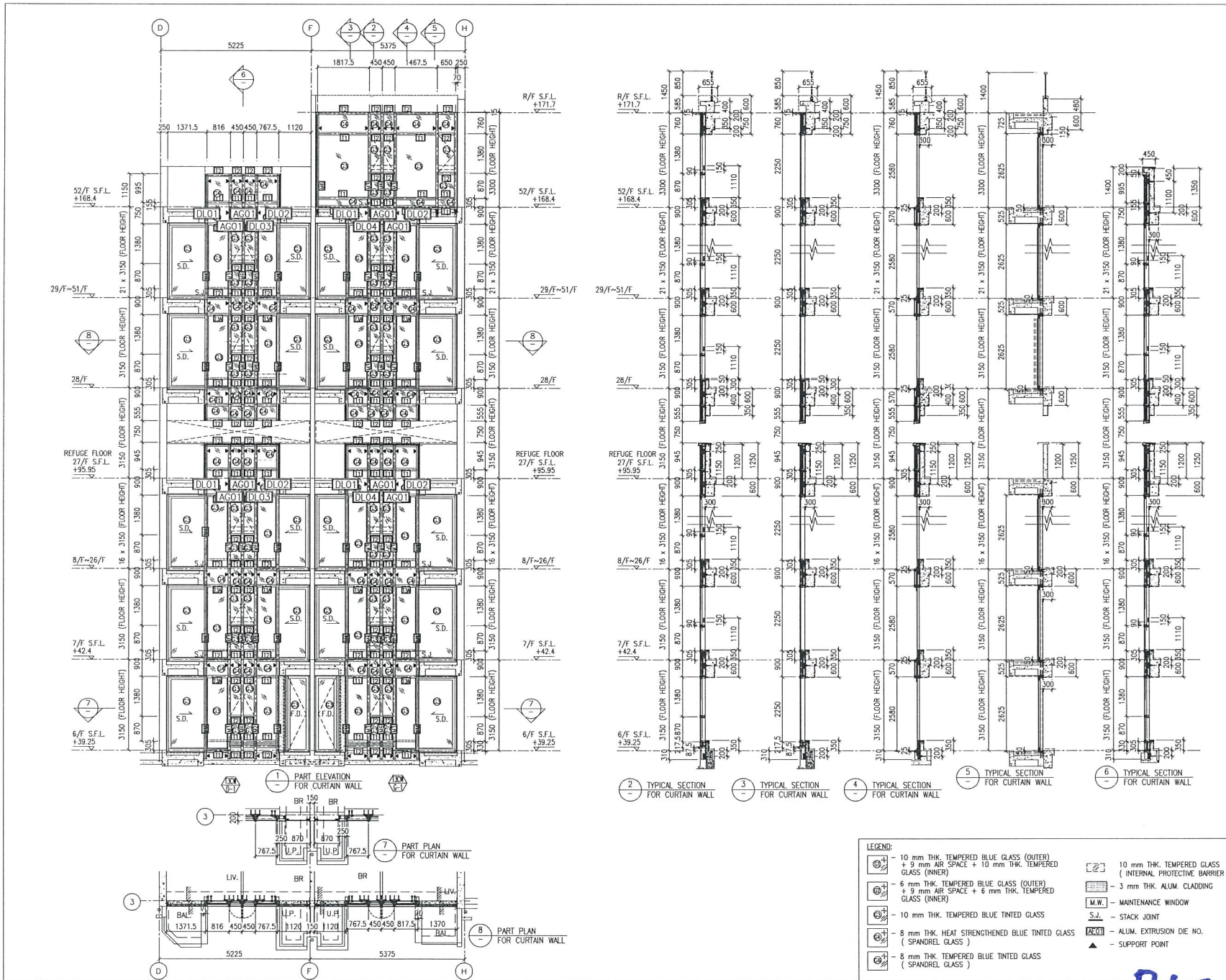

B.D. REF :

CLIENT :
 Sino Land Company Limited

ARCHITECT :
 WONG TUNG & PARTNERS LIMITED
 ARCHITECTS & PLANNERS

MAIN CONTRACTOR :
 CR Construction Company Limited

STRUCTURAL ENGINEER :
 AECOM

FAÇADE CONSULTANT :
 AECOM

NOTE :
 1. ALL DIMENSIONS ARE IN mm.
 2. ALL ELEVATIONS ARE VIEWED FROM OUTSIDE.
 3. ALL DIMENSIONS TO BE VERIFIED ON SITE BEFORE FABRICATION.

LEGEND :
 DETAIL MARK NO. REFER SHEET NO.
 1. F.F.L. — FINISHED FLOOR LEVEL
 2. S.F.L. — STRUCTURAL FLOOR LEVEL
 3. — REVERSED DETAIL

B	12/10/2018	GENERAL REVISED	
A	10/9/2018	GENERAL REVISED	
REV.	DATE	REVISED	BY

JOB NO. : J-837
 PROJECT : URA KWUN TONG TOWN CENTRE REDEVELOPMENT (AREA 2 & 3) AT NKIL 6514, KWUN TONG, KWLOON

TITLE : PART ELEVATION OF CURTAIN WALL OF TOWER 3

DATE : 04-JUL-18 SCALE : 1:60 (A1)
 DRAWN BY : ASING CHECKED BY : —
 M.T.D.I. MANUFACTURER LTD.
 Units 5-8, Sunny Industrial Centre, 1/F
 610 Cho Kwo Ling Road, Kowloon
 Tel:23489211-4 Fax:(852)2727666
 DWG NO. : JB37-CW-2311 REV. : B

- LEGEND:
- 10 mm THK. TEMPERED BLUE GLASS (OUTER) + 9 mm AIR SPACE + 10 mm THK. TEMPERED GLASS (INNER)
 - 6 mm THK. TEMPERED BLUE GLASS (OUTER) + 9 mm AIR SPACE + 6 mm THK. TEMPERED GLASS (INNER)
 - 10 mm THK. TEMPERED BLUE TINTED GLASS
 - 8 mm THK. HEAT STRENGTHENED BLUE TINTED GLASS (SPANDREL GLASS)
 - 8 mm THK. TEMPERED BLUE TINTED GLASS (SPANDREL GLASS)
 - 10 mm THK. TEMPERED GLASS (INTERNAL PROTECTIVE BARRIER)
 - 3 mm THK. ALUM. GLASSING
 - M.W. — MAINTENANCE WINDOW
 - S.J. — STACK JOINT
 - ALUM. EXTRUSION DIE NO.
 - SUPPORT POINT

P-55

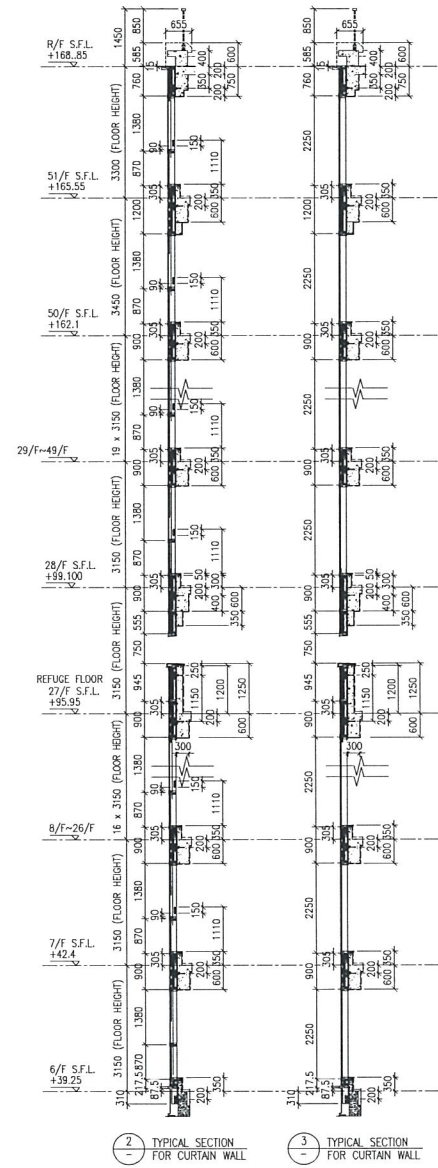
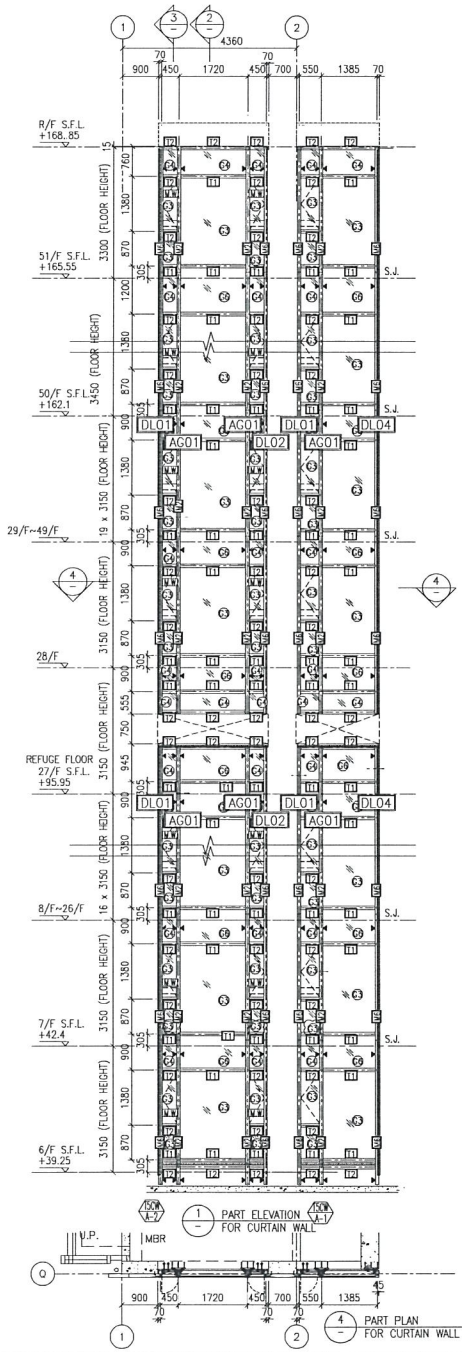

- LEGEND:**
- 10 mm THK. TEMPERED BLUE GLASS (OUTER) + 9 mm AIR SPACE + 10 mm THK. TEMPERED GLASS (INNER)
 - 6 mm THK. TEMPERED BLUE GLASS (OUTER) + 9 mm AIR SPACE + 6 mm THK. TEMPERED GLASS (INNER)
 - 10 mm THK. TEMPERED BLUE TINTED GLASS
 - 8 mm THK. HEAT STRENGTHENED BLUE TINTED GLASS (SPANDREL GLASS)
 - 8 mm THK. TEMPERED BLUE TINTED GLASS (SPANDREL GLASS)
 - 10 mm THK. TEMPERED GLASS (INTERNAL PROTECTIVE BARRIER)
 - 3 mm THK. ALUM. CLADDING
 - MAINTENANCE WINDOW
 - STACK JOINT
 - ALUM. EXTRUSION DIE NO.
 - SUPPORT POINT

B.D. REF :

CLIENT :
 Sino Land Company Limited

ARCHITECT :
 WONG TUNG & PARTNERS LIMITED ARCHITECTS & PLANNERS

MAIN CONTRACTOR :
 CR Construction Company Limited

STRUCTURAL ENGINEER :
 ACCOM

FACADE CONSULTANT :
 ACCOM

NOTE :

- ALL DIMENSIONS ARE IN mm.
- ALL ELEVATIONS ARE VIEWED FROM OUTSIDE.
- ALL DIMENSIONS TO BE VERIFIED ON SITE BEFORE FABRICATION.

LEGEND :

(X1) - DETAIL MARK NO.
(X001) - REFER SHEET NO.

- F.F.L. - FINISHED FLOOR LEVEL
- S.F.L. - STRUCTURAL FLOOR LEVEL
- (R) - REVERSED DETAIL

B	12/10/2018	GENERAL REVISED	
A	10/9/2018	GENERAL REVISED	
REV.	DATE	REVISION	BY

JOB NO. : J-837

PROJECT :
URA KWUN TONG TOWN CENTRE REDEVELOPMENT (AREA 2 & 3) AT NKIL 6514, KWUN TONG, KWLOON

TITLE :
PART ELEVATION OF CURTAIN WALL AT TOWER 5

DATE : 04-JUL-18 SCALE : 1:60 (A1)

DRAWN BY : ASING CHECKED BY : -

MIDI ALUMINIUM FABRICATOR LTD.
Units 5-8, Sunny Industrial Centre, 1/F
610 Cho Kwo Ling Road, Kwloon
Tel:23489211-4 Fax:(852)2727666

DWG NO. : JB37-CW-2501 REV. : B

P.57

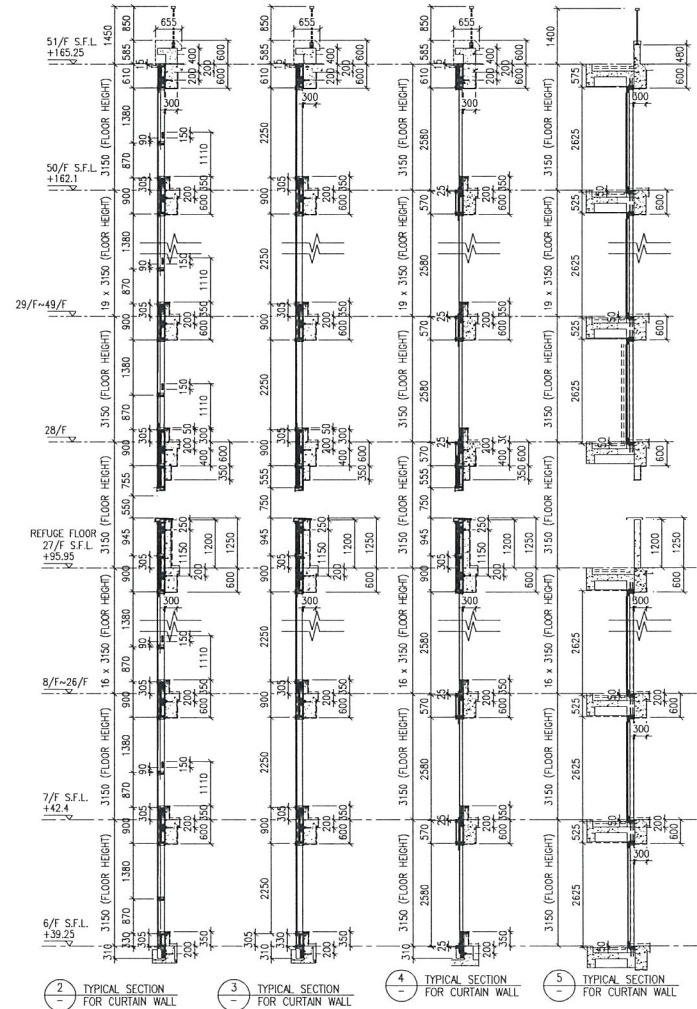
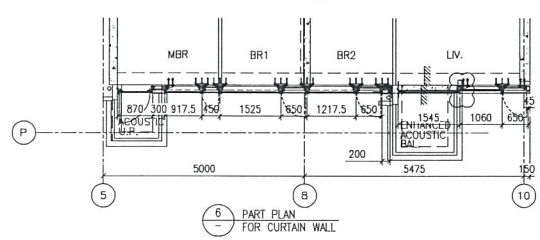
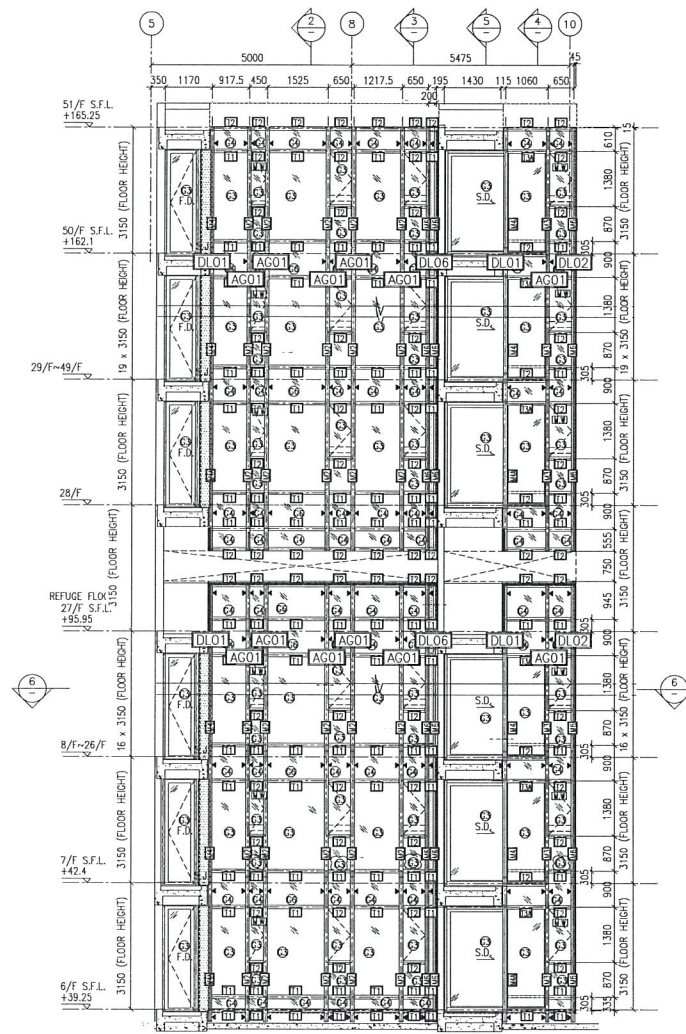

- LEGEND:**
- 10 mm THK. TEMPERED BLUE GLASS (OUTER) + 9 mm AIR SPACE + 10 mm THK. TEMPERED GLASS (INNER)
 - 6 mm THK. TEMPERED BLUE GLASS (OUTER) + 9 mm AIR SPACE + 6 mm THK. TEMPERED GLASS (INNER)
 - 10 mm THK. TEMPERED BLUE TINTED GLASS
 - 8 mm THK. HEAT STRENGTHENED BLUE TINTED GLASS (SPANDREL GLASS)
 - 8 mm THK. TEMPERED BLUE TINTED GLASS (SPANDREL GLASS)
 - 10 mm THK. TEMPERED GLASS (INTERNAL PROTECTIVE BARRIER)
 - 3 mm THK. ALUM. CLADDING
 - M.W. - MAINTENANCE WINDOW
 - S.J. - STACK JOINT
 - ALUM. - ALUM. EXTRUSION DIE NO.
 - SUPPORT POINT

B.D. REF :

CLIENT :
 Sino Land Company Limited

ARCHITECT :
 WONG TUNG & PARTNERS LIMITED ARCHITECTS & PLANNERS

MAIN CONTRACTOR :
 CR Construction Company Limited

STRUCTURAL ENGINEER :
 ACOM

FAÇADE CONSULTANT :
 ACOM

NOTE :
 1. ALL DIMENSIONS ARE IN mm.
 2. ALL ELEVATIONS ARE VIEWED FROM OUTSIDE.
 3. ALL DIMENSIONS TO BE VERIFIED ON SITE BEFORE FABRICATION.

LEGEND :
 - DETAIL MARK NO.
 - REFER SHEET NO.
 1. F.F.L. -- FINISHED FLOOR LEVEL
 2. S.F.L. -- STRUCTURAL FLOOR LEVEL
 3. (P) -- REVERSED DETAIL

B	12/10/2018	GENERAL REVISED
A	10/9/2018	GENERAL REVISED
NO.	DATE	REVISED

JOB NO. : J-837

PROJECT :
 URA KWUN TONG TOWN CENTRE REDEVELOPMENT (AREA 2 & 3) AT NKIL 6514, KWUN TONG, KWLOON

TITLE :
 PART ELEVATION OF CURTAIN WALL AT TOWER 5

DATE : 04-JUL-18	SCALE : 1:60 (A1)
DRAWN BY : ASING	CHECKED BY : -

MIDI ALUMINUM FABRICATOR LTD.
 Units 6-8, Sunway Industrial Centre, 1/F
 810 Che Koo Ling Road, Kwloon
 Tel:23489211-4 Fax:(852)2727666

DWG NO. : JB37-CW-2502 REV. : B

17.58

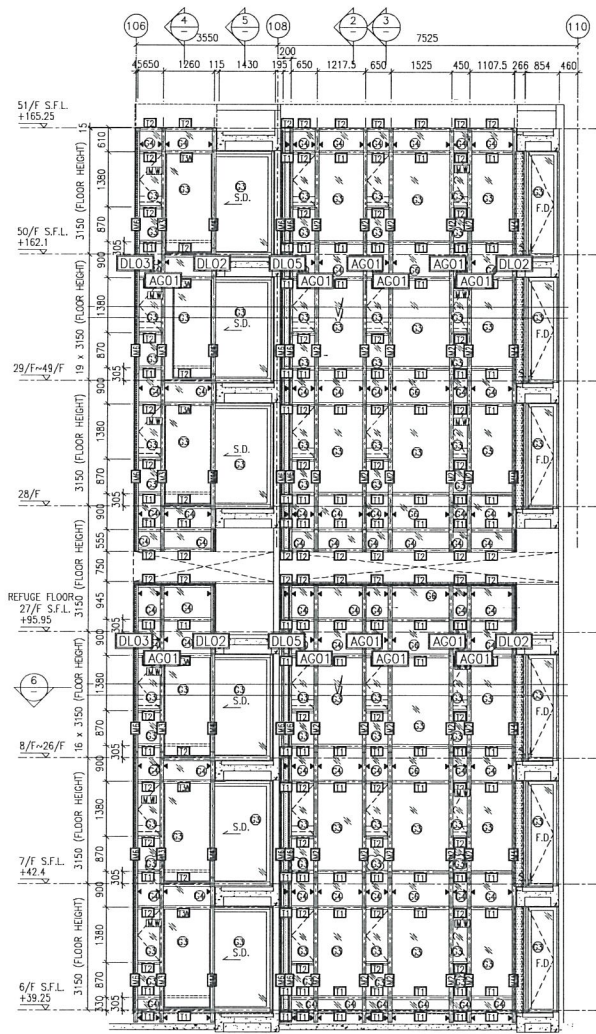

1 PART ELEVATION FOR CURTAIN WALL

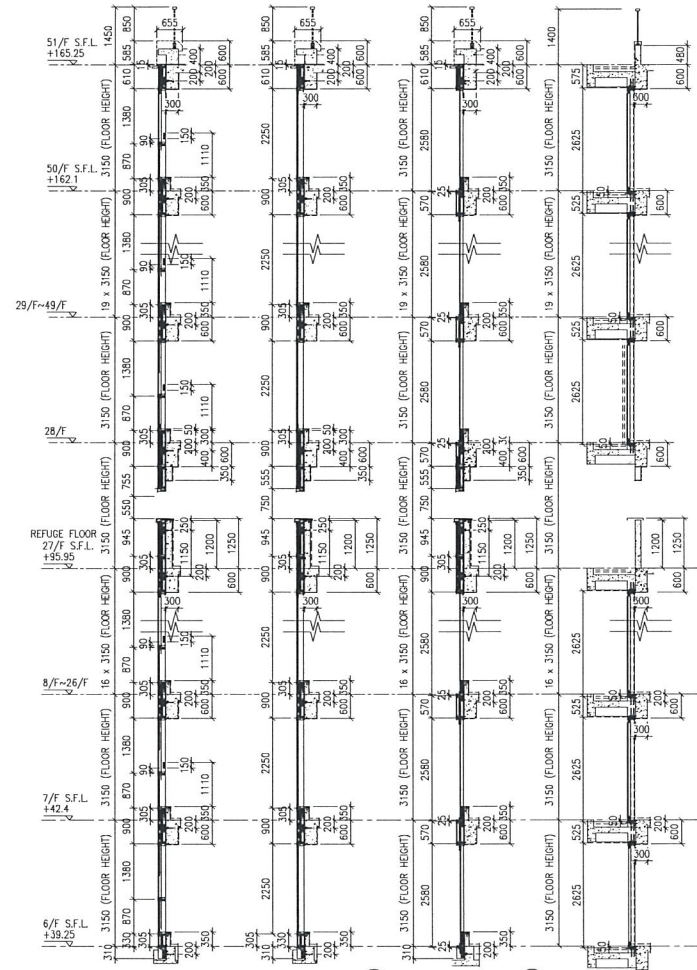

2 TYPICAL SECTION FOR CURTAIN WALL

3 TYPICAL SECTION FOR CURTAIN WALL

4 TYPICAL SECTION FOR CURTAIN WALL

5 TYPICAL SECTION FOR CURTAIN WALL

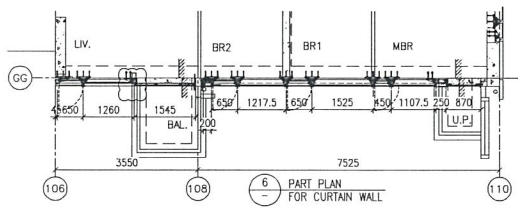

6 PART PLAN FOR CURTAIN WALL

- LEGEND:
- 10 mm THK. TEMPERED BLUE GLASS (OUTER) + 9 mm AIR SPACE + 10 mm THK. TEMPERED GLASS (INNER)
 - 6 mm THK. TEMPERED BLUE GLASS (OUTER) + 9 mm AIR SPACE + 6 mm THK. TEMPERED GLASS (INNER)
 - 10 mm THK. TEMPERED BLUE TINTED GLASS
 - 8 mm THK. HEAT STRENGTHENED BLUE TINTED GLASS (SPANDREL GLASS)
 - 8 mm THK. TEMPERED BLUE TINTED GLASS (SPANDREL GLASS)
 - 10 mm THK. TEMPERED GLASS (INTERNAL PROTECTIVE BARRIER)
 - 3 mm THK. ALUM. CLADDING
 - M.W. - MAINTENANCE WINDOW
 - S.J. - STACK JOINT
 - ACO1 - ALUM. EXTRUSION DIE NO.
 - SUPPORT POINT

P-59

B.D. REF :

CLIENT : Sino Land Company Limited

ARCHITECT : WONG TUNG & PARTNERS LIMITED ARCHITECTS & PLANNERS

MAIN CONTRACTOR : CR Construction Company Limited

STRUCTURAL ENGINEER : ACOM

FACADE CONSULTANT : ACOM

NOTE :

- ALL DIMENSIONS ARE IN mm.
- ALL ELEVATIONS ARE VIEWED FROM OUTSIDE.
- ALL DIMENSIONS TO BE VERIFIED ON SITE BEFORE FABRICATION.

LEGEND :

- DETAIL MARK NO.
- REFER SHEET NO.
- FINISHED FLOOR LEVEL
- STRUCTURAL FLOOR LEVEL
- REVERSED DETAIL

B	12/10/2018	GENERAL REWSED	
A	10/9/2018	GENERAL REWSED	
REV.	DATE	REWSED	BY

JOB NO. : J-837

PROJECT : URA KWUN TONG TOWN CENTRE REDEVELOPMENT (AREA 2 & 3) AT NKIL 6514, KWUN TONG, KWLOON

TITLE : PART ELEVATION OF CURTAIN WALL AT TOWER 5

DATE : 04-JUL-18	SCALE : 1:60 (A1)
DRAWN BY : ASING	CHECKED BY : -

美特鋁質有限公司
Units 6-8, Sunny Industrial Centre, 1/F
610 Che Kwo Ling Road, Kwunson
Tel: 23489211-4 Fax: (852) 2727666

DWG NO. : JB37-CW-2503 REV. : B

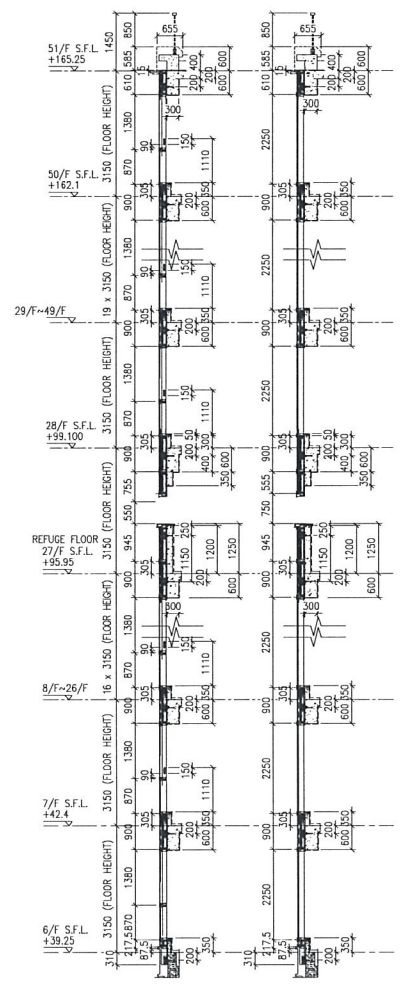
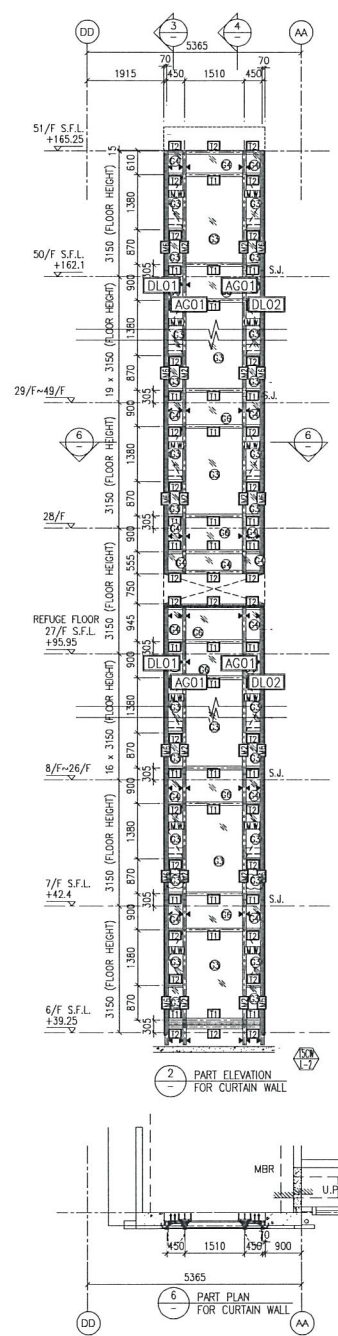
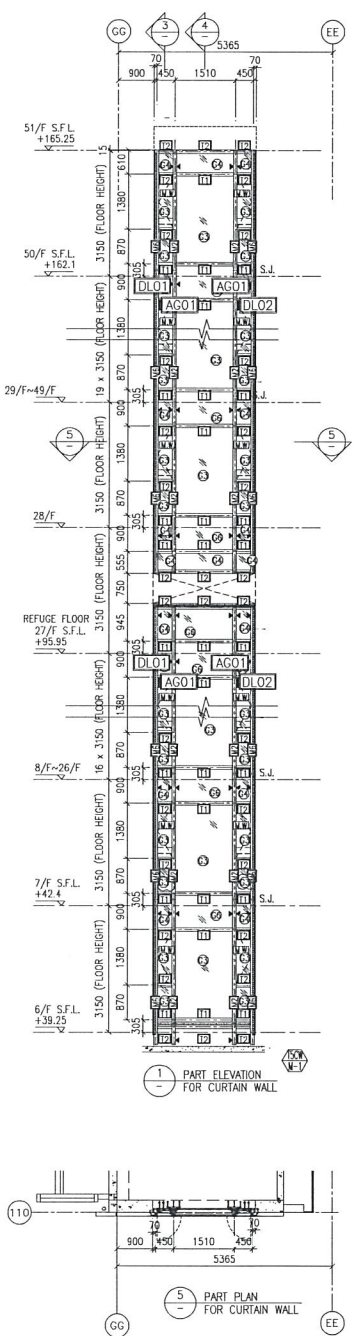

- LEGEND:**
- 10 mm THK. TEMPERED BLUE GLASS (OUTER) + 9 mm AIR SPACE + 10 mm THK. TEMPERED GLASS (INNER)
 - 6 mm THK. TEMPERED BLUE GLASS (OUTER) + 9 mm AIR SPACE + 6 mm THK. TEMPERED GLASS (INNER)
 - 10 mm THK. TEMPERED BLUE TINTED GLASS
 - 8 mm THK. HEAT STRENGTHENED BLUE TINTED GLASS (SPANDREL GLASS)
 - 8 mm THK. TEMPERED BLUE TINTED GLASS (SPANDREL GLASS)
 - 10 mm THK. TEMPERED GLASS (INTERNAL PROTECTIVE BARRIER)
 - 3 mm THK. ALUM. CLADDING
 - M.W. - MAINTENANCE WINDOW
 - S.J. - STACK JOINT
 - E.C.D.N. - ALUM. EXTRUSION DIE NO.
 - SUPPORT POINT

B.D. REF :

CLIENT : Sino Land Company Limited

ARCHITECT : WONG TUNG & PARTNERS LIMITED ARCHITECTS & PLANNERS

MAIN CONTRACTOR : CR Construction Company Limited

STRUCTURAL ENGINEER : AECOM

FACADE CONSULTANT : AECOM

NOTE :

- ALL DIMENSIONS ARE IN mm.
- ALL ELEVATIONS ARE VIEWED FROM OUTSIDE.
- ALL DIMENSIONS TO BE VERIFIED ON SITE BEFORE FABRICATION.

LEGEND :

- DETAIL MARK NO.
- REFER SHEET NO.

- F.F.L. - FINISHED FLOOR LEVEL
- S.F.L. - STRUCTURAL FLOOR LEVEL
- (R) - REVERSED DETAIL

B	12/10/2018	GENERAL	REVISED
A	10/9/2018	GENERAL	REVISED
NO.	DATE	REVISION	BY

JOB NO. : J-837

PROJECT : URA KWUN TONG TOWN CENTRE REDEVELOPMENT (AREA 2 & 3) AT NKIL 6514, KWUN TONG, KWLOON

TITLE : PART ELEVATION OF CURTAIN WALL AT TOWER 5

DATE : 04-JUL-18 SCALE : 1:60 (A1)

DRAWN BY : ASING CHECKED BY : -

MIDI ALUMINUM FABRICATOR LTD.
Units 5-8, Sunny Industrial Centre, 1/F
610 Cha Kwo Ling Road, Kwloon
Tel: 23489211-4 Fax: (852) 27272666

DWG NO. : JB37-CW-2504 REV. : B

P-60

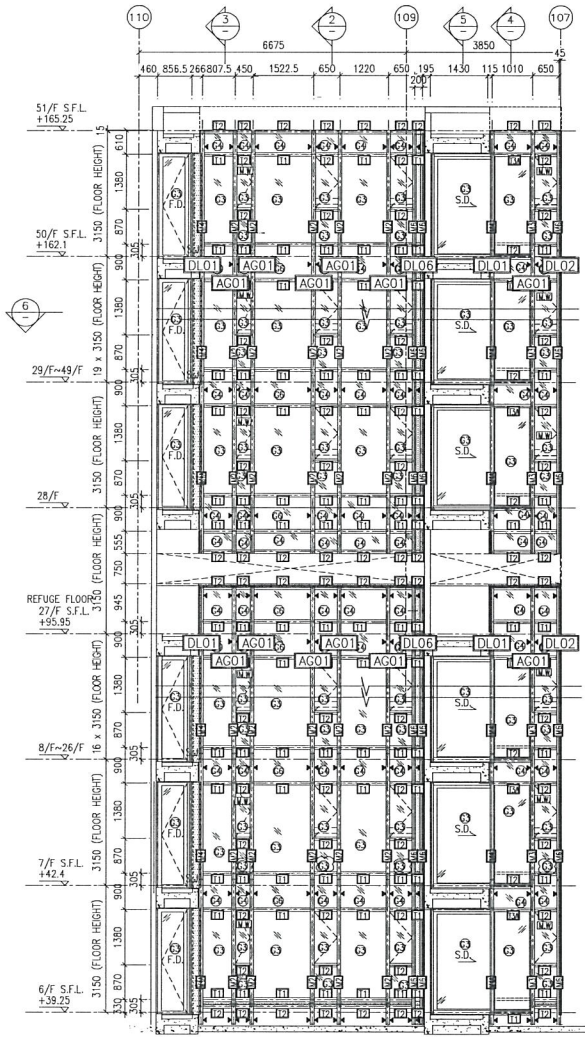

1 PART ELEVATION FOR CURTAIN WALL

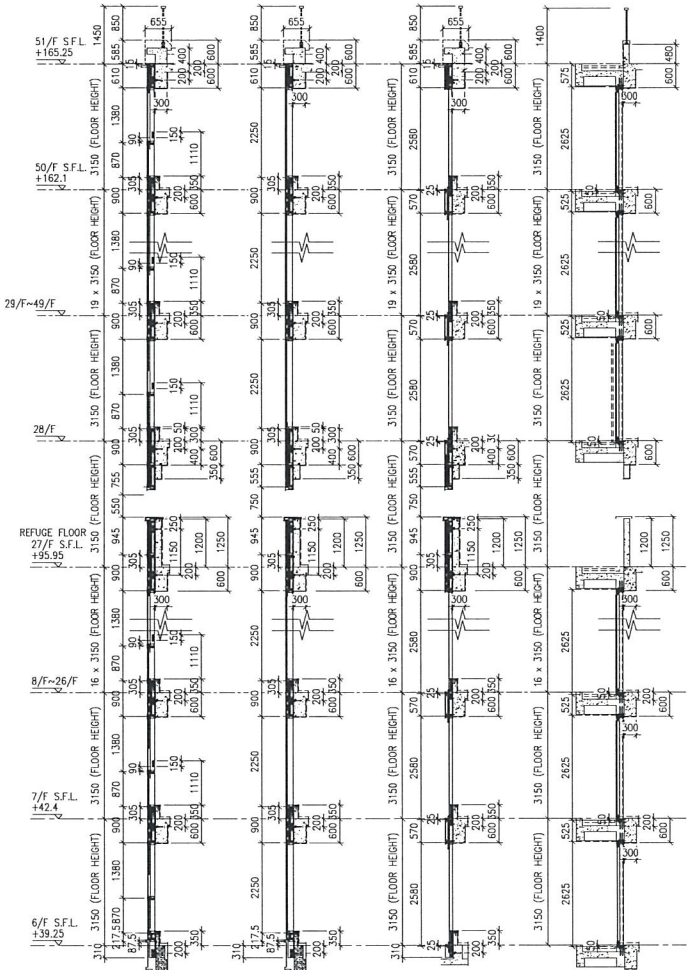

2 TYPICAL SECTION FOR CURTAIN WALL
3 TYPICAL SECTION FOR CURTAIN WALL
4 TYPICAL SECTION FOR CURTAIN WALL
5 TYPICAL SECTION FOR CURTAIN WALL

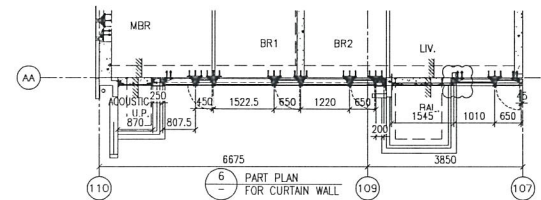

6 PART PLAN FOR CURTAIN WALL

- LEGEND:**
- 10 mm THK. TEMPERED BLUE GLASS (OUTER) + 9 mm AIR SPACE + 10 mm THK. TEMPERED GLASS (INNER)
 - 6 mm THK. TEMPERED BLUE GLASS (OUTER) + 9 mm AIR SPACE + 6 mm THK. TEMPERED GLASS (INNER)
 - 10 mm THK. TEMPERED BLUE TINTED GLASS
 - 8 mm THK. HEAT STRENGTHENED BLUE TINTED GLASS (SPANDREL GLASS)
 - 8 mm THK. TEMPERED BLUE TINTED GLASS (SPANDREL GLASS)
 - 10 mm THK. TEMPERED GLASS (INTERNAL PROTECTIVE BARRIER)
 - 3 mm THK. ALUM. CLADDING
 - M.W. - MAINTENANCE WINDOW
 - S.J. - STACK JOINT
 - AE01 - ALUM. EXTRUSION DIE NO.
 - ▲ - SUPPORT POINT

B.D. REF :	
CLIENT : 信和置業有限公司 Sino Land Company Limited	
ARCHITECT : WONG TUNG & PARTNERS LIMITED ARCHITECTS & PLANNERS	
MAIN CONTRACTOR : CR Construction Company Limited	
STRUCTURAL ENGINEER : AECOM	
FACADE CONSULTANT: AECOM	
NOTE: 1. ALL DIMENSIONS ARE IN mm. 2. ALL ELEVATIONS ARE VIEWED FROM OUTSIDE. 3. ALL DIMENSIONS TO BE VERIFIED ON SITE BEFORE FABRICATION.	
LEGEND: X1 - DETAIL MARK NO. X2001 - REFER SHEET NO.	
1. F.F.L. -- FINISHED FLOOR LEVEL 2. S.F.L. -- STRUCTURAL FLOOR LEVEL 3. (P) -- REVERSED DETAIL	
B	12/10/2018 GENERAL REVISED
A	10/9/2018 GENERAL REVISED
NO.	DATE REVISED BY
JOB NO. : J-837	
PROJECT : URA KWUN TONG TOWN CENTRE REDEVELOPMENT (AREA 2 & 3) AT NKIL 6514, KWUN TONG, KWLOON	
TITLE : PART ELEVATION OF CURTAIN WALL AT TOWER 5	
DATE : 04-JUL-18	SCALE : 1:60 (A1)
DRAWN BY : ASING CHECKED BY : -	
美特鋁質有限公司 MIDI ALUMINIUM FABRICATOR LTD. Units 6-8, Sunny Industrial Centre, 1/F 810 Che Kwo Ling Road, Kwloon Tel:23489211-4 Fax:(852)2727666	
DWG NO. : JB37-CW-2505	REV. : B

P61

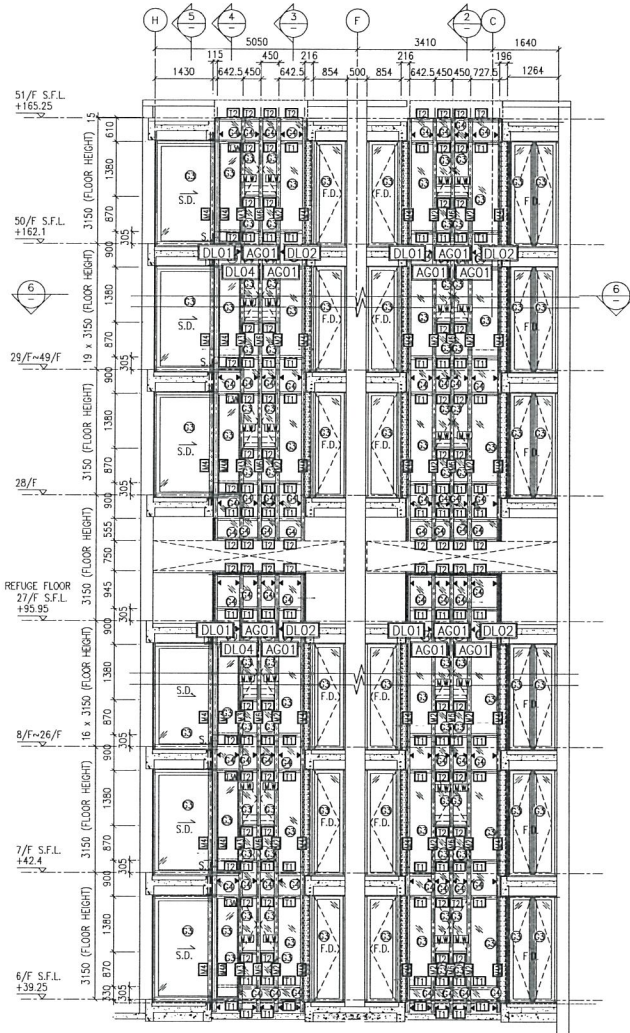

1 PART ELEVATION FOR CURTAIN WALL

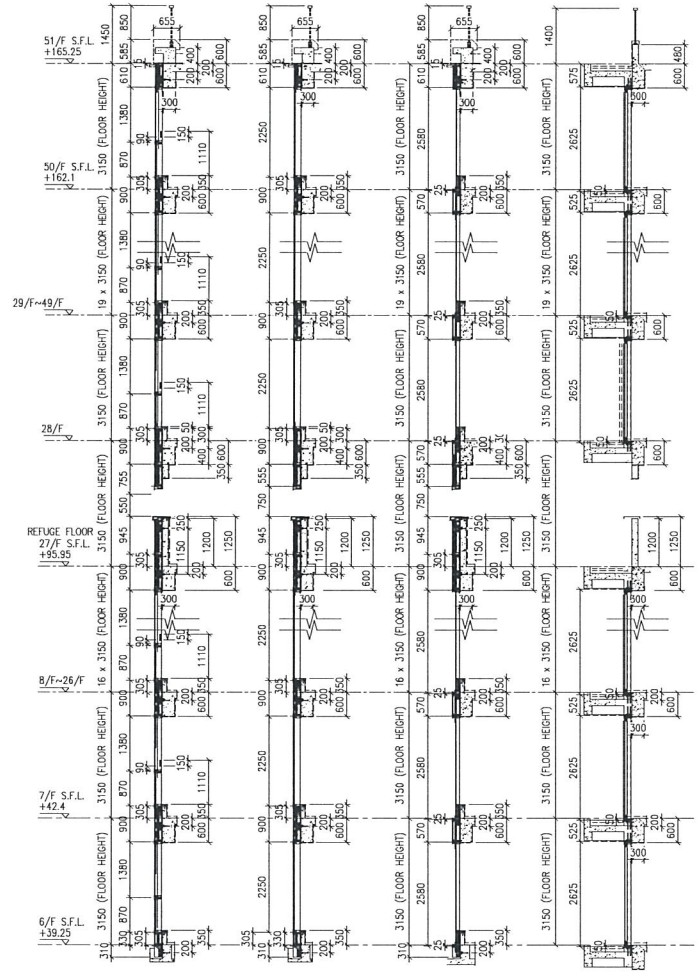

2 TYPICAL SECTION FOR CURTAIN WALL
3 TYPICAL SECTION FOR CURTAIN WALL
4 TYPICAL SECTION FOR CURTAIN WALL
5 TYPICAL SECTION FOR CURTAIN WALL

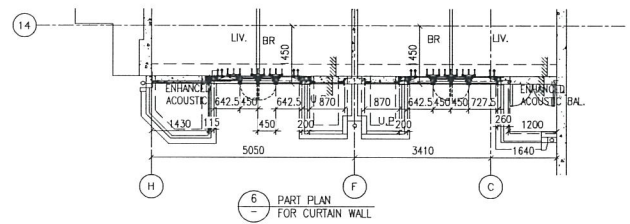

6 PART PLAN FOR CURTAIN WALL

- LEGEND:
- ① 10 mm THK. TEMPERED BLUE GLASS (OUTER) + 9 mm AIR SPACE + 10 mm THK. TEMPERED GLASS (INNER)
 - ② 6 mm THK. TEMPERED BLUE GLASS (OUTER) + 9 mm AIR SPACE + 6 mm THK. TEMPERED GLASS (INNER)
 - ③ 10 mm THK. TEMPERED BLUE TINTED GLASS
 - ④ 8 mm THK. HEAT STRENGTHENED BLUE TINTED GLASS (SPANDREL GLASS)
 - ⑤ 8 mm THK. TEMPERED BLUE TINTED GLASS (SPANDREL GLASS)
 - ⑥ 10 mm THK. TEMPERED GLASS (INTERNAL PROTECTIVE BARRIER)
 - ⑦ 3 mm THK. ALUM. CLADDING
 - M.M. - MAINTENANCE WINDOW
 - S.J. - STACK JOINT
 - ALUM. - ALUM. EXTRUSION DIE NO.
 - ▲ - SUPPORT POINT

B.D. REF :

CLIENT :
 Sino Land Company Limited

ARCHITECT :
 WONG TUNG & PARTNERS LIMITED ARCHITECTS & PLANNERS

MAIN CONTRACTOR :
 CR Construction Company Limited

STRUCTURAL ENGINEER :
 ACCOM

FAÇADE CONSULTANT :
 ACCOM

NOTE :
 1. ALL DIMENSIONS ARE IN mm.
 2. ALL ELEVATIONS ARE VIEWED FROM OUTSIDE.
 3. ALL DIMENSIONS TO BE VERIFIED ON SITE BEFORE FABRICATION.

LEGEND :
 (X1) - DETAIL MARK NO.
 (X001) - REFER SHEET NO.
 1. F.F.L. - FINISHED FLOOR LEVEL
 2. S.F.L. - STRUCTURAL FLOOR LEVEL
 3. (R) - REVERSED DETAIL.

B	12/10/2018	GENERAL REVISED
A	10/9/2018	GENERAL REVISED
NO.	DATE	REVISED
		BY

JOB NO. : J-837

PROJECT :
 URA KWUN TONG TOWN CENTRE REDEVELOPMENT (AREA 2 & 3) AT NKIL 6514, KWUN TONG, KWLOON

TITLE :
 PART ELEVATION OF CURTAIN WALL AT TOWER 5

DATE : 04-JUL-18 SCALE : 1:60 (A1)

DRAWN BY : ASING CHECKED BY : -

MIDI ALUMINUM FABRICATOR LTD.
 Units 6-8, Sunny Industrial Centre, 1/F
 610 Che Kwo Ling Road, Kwailoon
 Tel: 23489211-4 Fax: (852) 2727666

DWG NO. : JB37-CW-2506 REV. : B

P-62

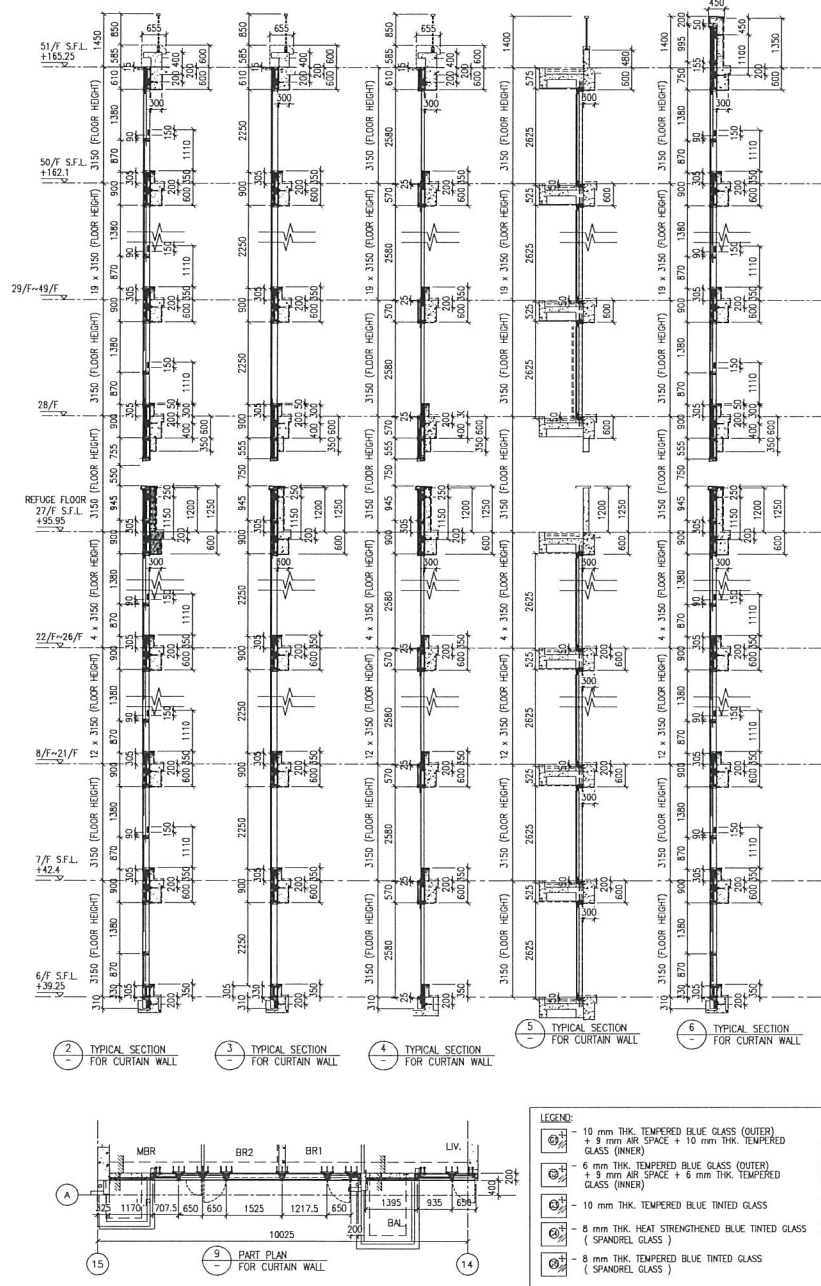
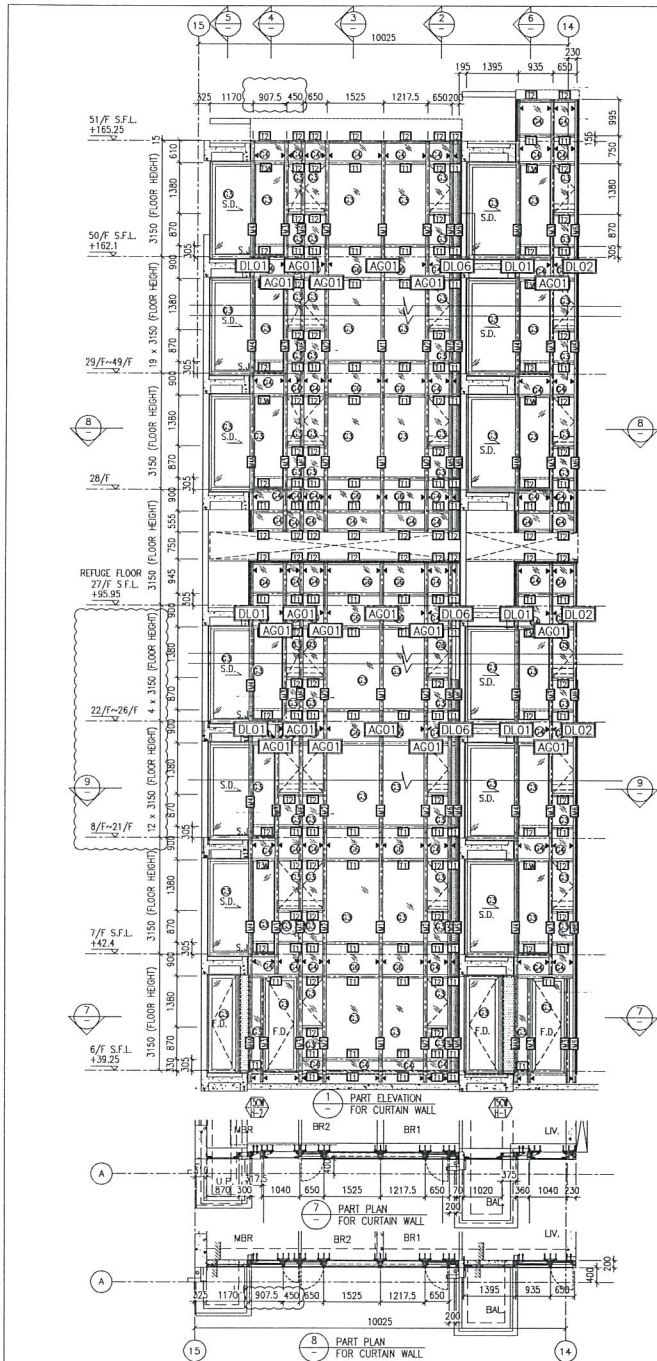

LEGEND:

	10 mm THK. TEMPERED BLUE GLASS (OUTER) + 9 mm AIR SPACE + 10 mm THK. TEMPERED GLASS (INNER)		10 mm THK. TEMPERED GLASS (INTERNAL PROTECTIVE BARRIER)
	6 mm THK. TEMPERED BLUE GLASS (OUTER) + 9 mm AIR SPACE + 6 mm THK. TEMPERED GLASS (INNER)		3 mm THK. ALUM. CLADDING
	10 mm THK. TEMPERED BLUE TINTED GLASS		MAINTENANCE WINDOW
	8 mm THK. HEAT STRENGTHENED BLUE TINTED GLASS (SPANDREL GLASS)		STACK JOINT
	8 mm THK. TEMPERED BLUE TINTED GLASS (SPANDREL GLASS)		ALUM. EXTRUSION DIE NO.
			SUPPORT POINT

7.64

B.D. REF :

CLIENT : 隆和置業有限公司 Sino Land Company Limited

ARCHITECT : WONG TUNG & PARTNERS LIMITED ARCHITECTS & PLANNERS

MAIN CONTRACTOR : CR Construction Company Limited

STRUCTURAL ENGINEER : ACOM

FACADE CONSULTANT : ACOM

NOTE :

- ALL DIMENSIONS ARE IN mm.
- ALL ELEVATIONS ARE VIEWED FROM OUTSIDE.
- ALL DIMENSIONS TO BE VERIFIED ON SITE BEFORE FABRICATION.

LEGEND :

(X1) - DETAIL MARK NO.
(X001) - REFER SHEET NO.

1. F.F.L. - FINISHED FLOOR LEVEL
2. S.F.L. - STRUCTURAL FLOOR LEVEL
3. (R) - REVERSED DETAIL

B	12/10/2018	GENERAL REVISED
A	10/9/2018	GENERAL REVISED
NO.	DATE	REVISED BY

JOB NO. : J-837

PROJECT : URA KWUN TONG TOWN CENTRE REDEVELOPMENT (AREA 2 & 3) AT NKIL 6514, KWUN TONG, KWLOON

TITLE : PART ELEVATION OF CURTAIN WALL AT TOWER 5

DATE : 04-JUL-18	SCALE : 1:60 (A1)
DRAWN BY : ASING	CHECKED BY : -

美特鋁質有限公司
MIDI ALUMINUM FABRICATOR LTD.
Units 6-8, Sunray Industrial Centre, 1/F
610 Che Kwo Ling Road, Kowloon
Tel:23489211-4 Fax:(852)2727666

DWG NO. : JB37-CW-2508 REV. : B

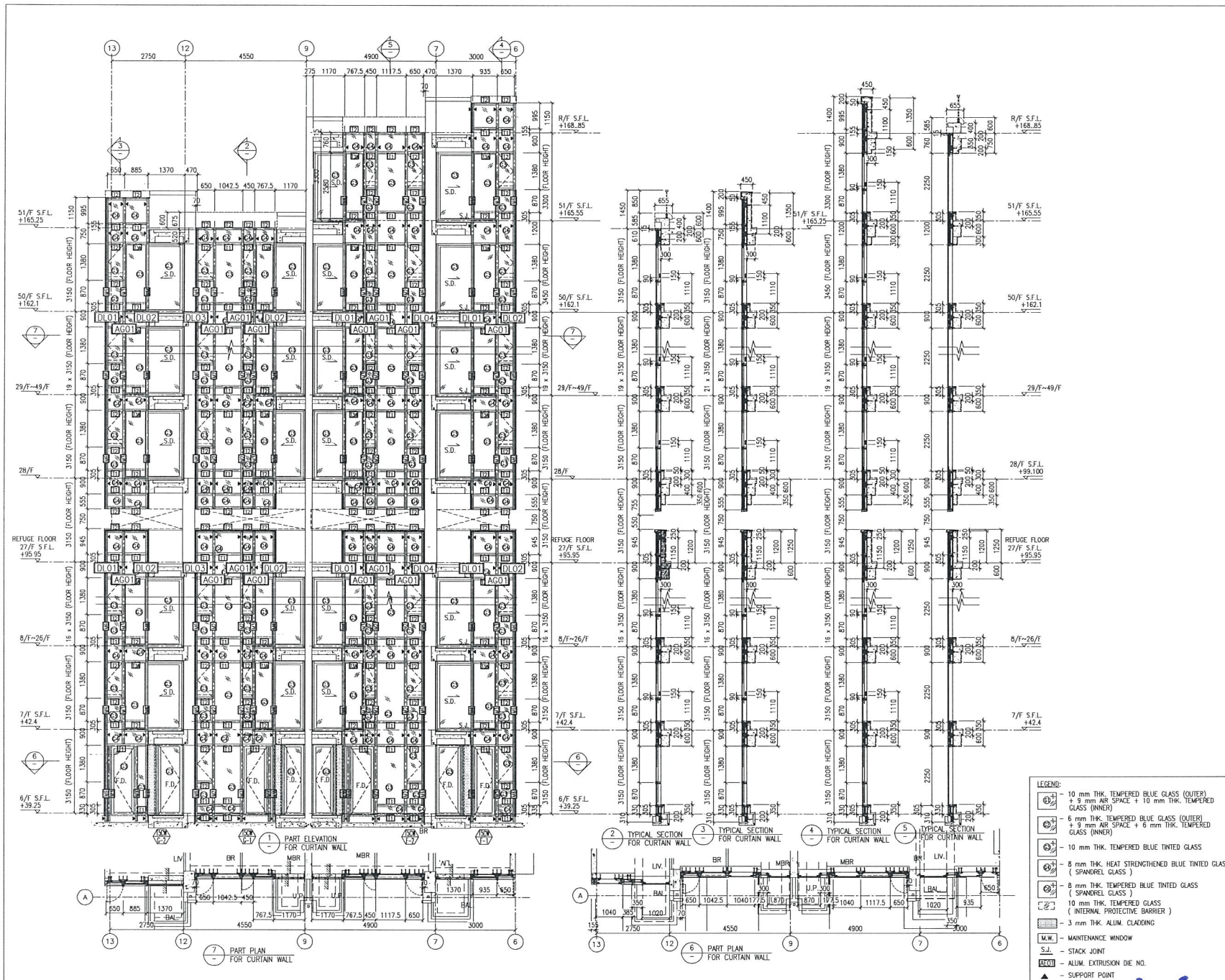

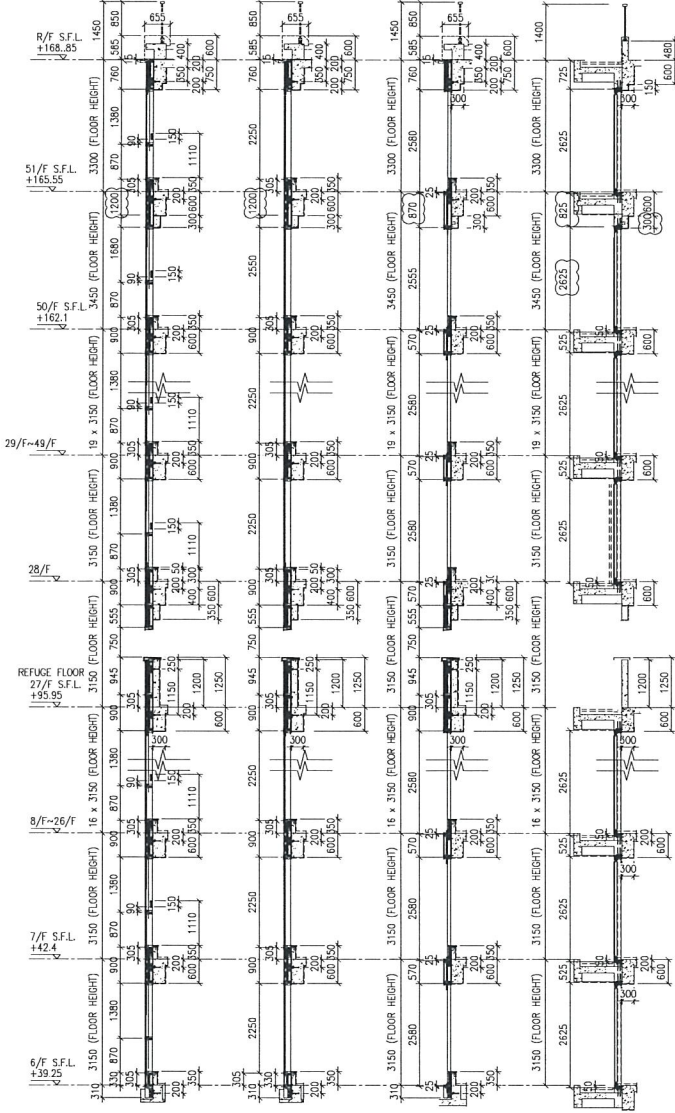
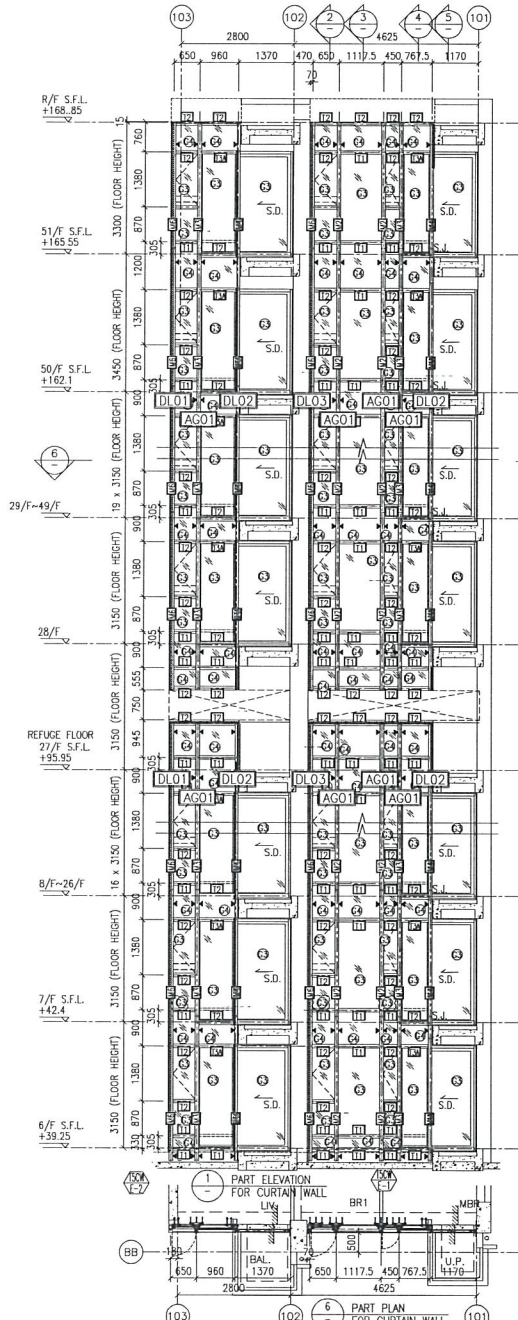

- LEGEND:**
- 10 mm THK TEMPERED BLUE GLASS (OUTER) + 9 mm AIR SPACE + 10 mm THK TEMPERED GLASS (INNER)
 - 6 mm THK TEMPERED BLUE GLASS (OUTER) + 5 mm AIR SPACE + 6 mm THK TEMPERED GLASS (INNER)
 - 10 mm THK TEMPERED BLUE TINTED GLASS
 - 8 mm THK HEAT STRENGTHENED BLUE TINTED GLASS (SPANDEL GLASS)
 - 8 mm THK TEMPERED BLUE TINTED GLASS (SPANDEL GLASS)
 - 10 mm THK TEMPERED GLASS (INTERNAL PROTECTIVE BARRIER)
 - 3 mm THK ALUM. CLADDING
 - MAINTENANCE WINDOW
 - STACK JOINT
 - ALUM. EXTRUSION DIE NO.
 - SUPPORT POINT

B.D. REF :

CLIENT : **WONG TUNG & PARTNERS LIMITED ARCHITECTS & PLANNERS**
WONG TUNG & PARTNERS LIMITED
 Sino Land Company Limited

ARCHITECT : **WONG TUNG & PARTNERS LIMITED ARCHITECTS & PLANNERS**
WTP

MAIN CONTRACTOR : **CR Construction Company Limited**

STRUCTURAL ENGINEER : **ACOM**

FAÇADE CONSULTANT : **ACOM**

NOTE :
 1. ALL DIMENSIONS ARE IN mm.
 2. ALL ELEVATIONS ARE VIEWED FROM OUTSIDE.
 3. ALL DIMENSIONS TO BE VERIFIED ON SITE BEFORE FABRICATION.

LEGEND :
 (X1) - DETAIL MARK NO.
 (X001) - REFER SHEET NO.

1. F.F.L. -- FINISHED FLOOR LEVEL
 2. S.F.L. -- STRUCTURAL FLOOR LEVEL
 3. (R) -- REVERSED DETAIL.

B	12/10/2018	GENERAL REWSED
A	10/9/2018	GENERAL REWSED
NO.	DATE	REWSED BY

JOB NO. : J-837

PROJECT : URA KWUN TONG TOWN CENTRE REDEVELOPMENT (AREA 2 & 3) AT NKIL 6514, KWUN TONG, KWLOON

TITLE : PART ELEVATION OF CURTAIN WALL AT TOWER 5

DATE : 04-JUL-18	SCALE : 1:60 (A1)
DRAWN BY : ASING	CHECKED BY : -

美特鋁質有限公司
MIDI ALUMINIUM FABRICATOR LTD.
 Units 6-8, Sunray Industrial Centre, 1/F
 1810 Che Kwo Ling Road, Kwloon
 Tel: 23489211-4 Fax: (852) 2727666

DWG NO. : JB37-CW-2510 REV. : B

P.66

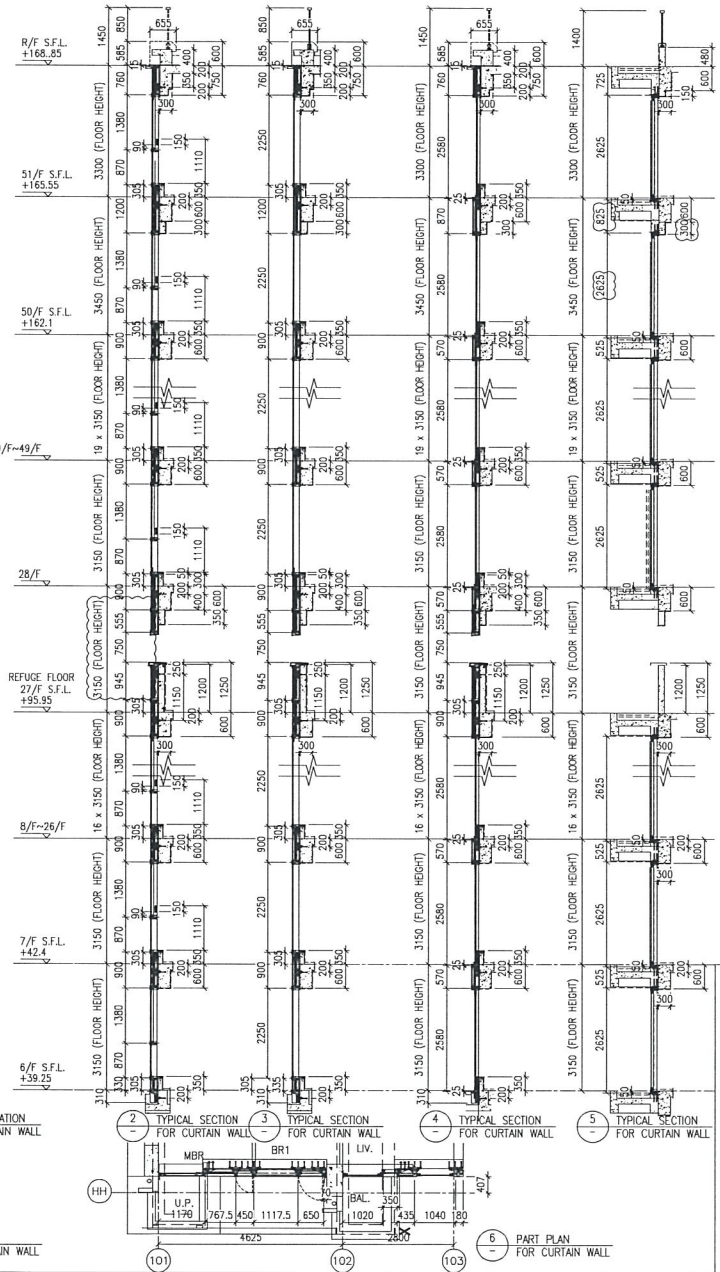
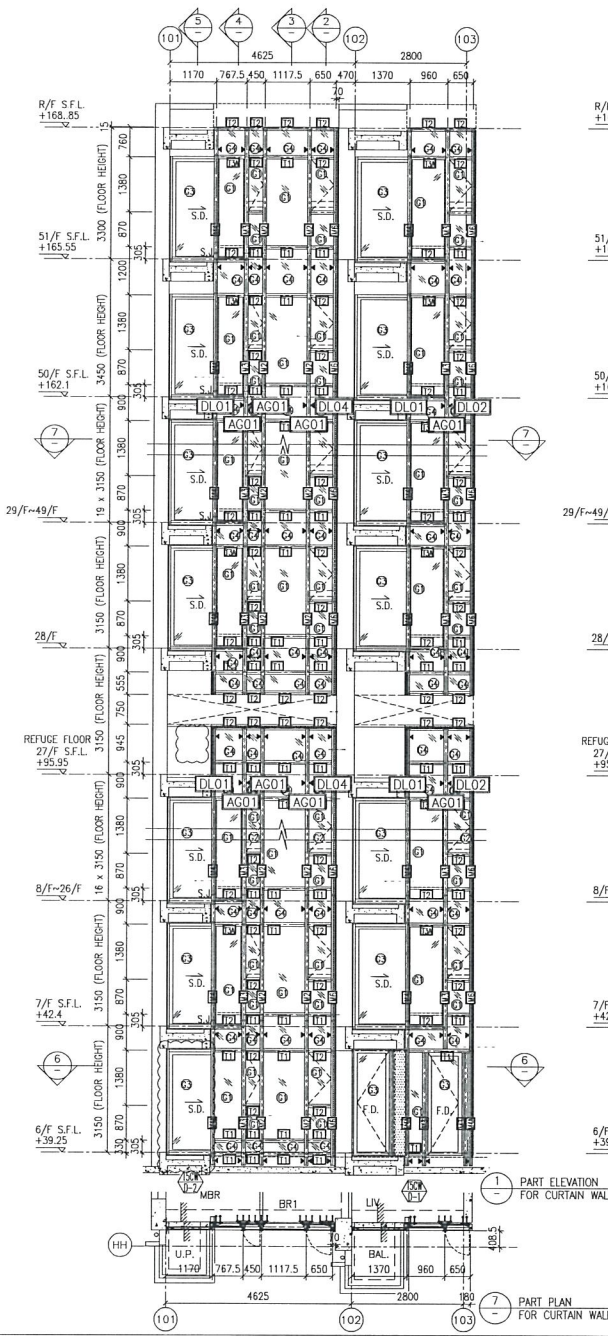

- LEGEND:**
- 10 mm THK. TEMPERED BLUE GLASS (OUTER) + 9 mm AIR SPACE + 10 mm THK. TEMPERED GLASS (INNER)
 - 6 mm THK. TEMPERED BLUE GLASS (OUTER) + 9 mm AIR SPACE + 6 mm THK. TEMPERED GLASS (INNER)
 - 10 mm THK. TEMPERED BLUE TINTED GLASS
 - 8 mm THK. HEAT STRENGTHENED BLUE TINTED GLASS (SPANDREL GLASS)
 - 8 mm THK. TEMPERED BLUE TINTED GLASS (SPANDREL GLASS)
 - 10 mm THK. TEMPERED GLASS (INTERNAL PROTECTIVE BARRIER)
 - 3 mm THK. ALUM. CLADDING
 - MAINTENANCE WINDOW
 - STACK JOINT
 - ALUM. EXTRUSION DIE NO.
 - SUPPORT POINT

B.D. REF :

CLIENT : 新和置業有限公司 Sino Land Company Limited

ARCHITECT : WONG TUNG & PARTNERS LIMITED ARCHITECTS & PLANNERS

MAIN CONTRACTOR : CR Construction Company Limited

STRUCTURAL ENGINEER : ACOM

FAÇADE CONSULTANT : ACOM

NOTE :

- ALL DIMENSIONS ARE IN MM.
- ALL ELEVATIONS ARE VIEWED FROM OUTSIDE.
- ALL DIMENSIONS TO BE VERIFIED ON SITE BEFORE FABRICATION.

LEGEND :

- DETAIL MARK NO.
- REFER SHEET NO.

1. F.F.L. --- FINISHED FLOOR LEVEL
2. S.F.L. --- STRUCTURAL FLOOR LEVEL
3. (R) --- REVERSED DETAIL

A	10/9/2018	GENERAL REVISION
REV.	DATE	REVISION

JOB NO. : J-837

PROJECT : URA KWUN TONG TOWN CENTRE REDEVELOPMENT (AREA 2 & 3) AT NKIL 6514, KWUN TONG, KWLOON

TITLE : PART ELEVATION OF CURTAIN WALL AT TOWER 5

DATE : 04-JUL-18 SCALE : 1:60 (A1)

DRAWN BY : ASING CHECKED BY : -

美特鋁質有限公司 MIDALUMINIUM FABRICATOR LTD. Units 6-8, Sunray Industrial Centre, 1/F 610 Che Kwo Ling Road, Kwailoon Tel:23489211-4 Fax:(852)2727666

DWG NO. : J837-CW-2511 REV. : A

P-67

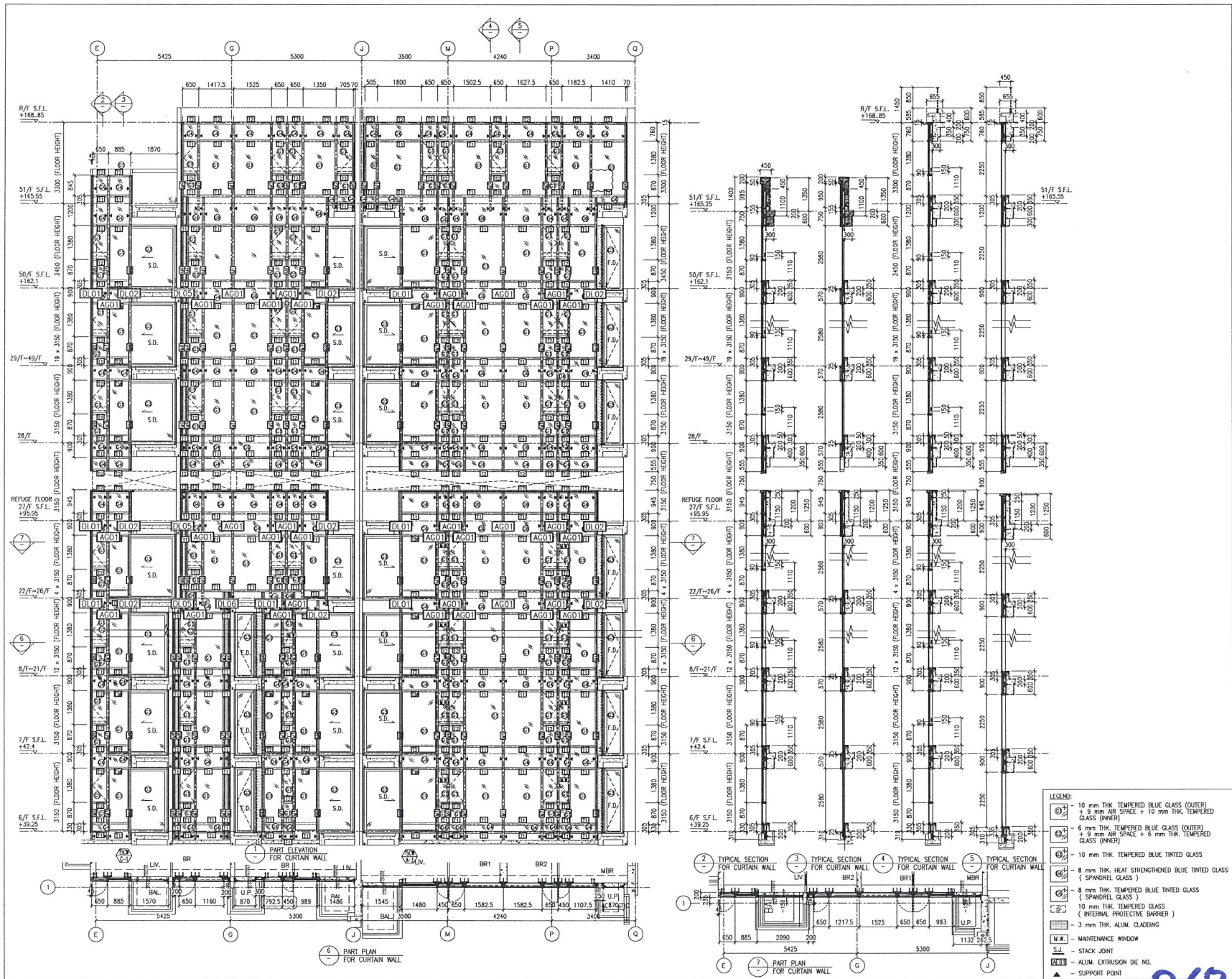

B.D. REF :

CLIENT : **新和置業有限公司**
Sino Land Company Limited

ARCHITECT : **WONG TUNG & PARTNERS LIMITED**
ARCHITECTS & PLANNERS

MAIN CONTRACTOR : **CR Construction Company Limited**

STRUCTURAL ENGINEER : **AZCOM**

FAÇADE CONSULTANT : **AZCOM**

NOTE :

1. ALL DIMENSIONS ARE IN mm.
2. ALL ELEVATIONS ARE VIEWED FROM OUTSIDE.
3. ALL DIMENSIONS TO BE VERIFIED ON SITE BEFORE FABRICATION.

LEGEND :

- (X1) — DETAIL MARK NO.
- (X000) — REFER SHEET NO.

1. F.F.L. — FINISHED FLOOR LEVEL
2. S.F.L. — STRUCTURAL FLOOR LEVEL
3. (R) — REVERSED DETAIL

B	12/10/2018	GENERAL REVISED
A	10/9/2018	GENERAL REVISED
REV	DATE	REVISION

JOB NO. : J-837

PROJECT : URA KWUN TONG TOWN CENTRE REDEVELOPMENT (AREA 2 & 3) AT NKIL 6514, KWUN TONG, KWLOON

TITLE : PART ELEVATION OF CURTAIN WALL AT TOWER 5

DATE : 04-JUL-18 SCALE : 1:60 (A1)

DRAWN BY : ASING CHECKED BY : —

美特鋁質有限公司
MIDI ALUMINIUM FABRICATOR LTD.
Units 6-8, Sunny Industrial Centre, 1/F
610 Cha Kwo Ling Road, Kowloon
Tel: 23489211-4 Fax: (852) 27276666

DWG NO. : JB37-CW-2512 REV. : B

P-68