



工程指示 / 要求簡箋(E.I.)

工程指示編號：EI / 9762 / 18

修改版次：C

工程編號：J - 837

工程名稱：觀塘裕民坊

工程項目：幕牆 試水箱拆圖

收件人：生統 / 永林

發件人：Eric Liu

日期：18/05/2019

要求提供 / 確認 事項：

- | | | |
|------------------------------------|-------------------------------------|-------------------------------|
| <input type="checkbox"/> 初步鋁料 B.M. | <input type="checkbox"/> 加工拆圖，然後生產 | <input type="checkbox"/> 尺寸表 |
| <input type="checkbox"/> 正式鋁料 B.M. | <input type="checkbox"/> 技術上資料 / 指示 | <input type="checkbox"/> 報價 |
| <input type="checkbox"/> 配件 B.M. | <input type="checkbox"/> 樣辦或貨品說明書 | <input type="checkbox"/> 分判合約 |
| <input type="checkbox"/> 其他：_____ | | |

內容：

請按試水箱大圖拆圖

包括：1. 鐵件 2. 鋁料 3. 玻璃 4. 配件

C 版提供第 3 次修改試水箱大圖(05.12 版本)

因應 BD 入則，增加 650 生窗及修改企料(見 5007 Detail)

謝謝

☆ 計 BM (鐵件, 配件, 鐵料)

玻璃已出. A版增加數量 (E20543A)

請在 2019/05/20 22 完成。

附：18 頁大圖+CAD

以上項目為：

- 原合約工程包 原合約工程加 / 減賬 新工程報價

原因：-

分發東莞各部門：

- () 生產技術總監 連附件 () 技術部 連附件 () 生產部 連附件 () 機械設計部 連附件
 () 採購部 連附件 () 生產統籌部 連附件
 () 質檢部 連附件 () 會計部 連附件 () 報關組 連附件 () 其他 楊榮輝 連附件

分發其他分判：

- () 王禮秋 連附件

分發香港各部門：

- () 行政部 連附件 () 會計部 連附件 () 統籌部 連附件 () 工程部地盤科文 連附件 請轉交
 () 採購部 連附件 () QS 部 連附件 () 維修部 連附件 () 其他 _____ 連附件

傳遞編號：

HK 1143/19

發件人簽署：

項目經理簽署：

PROJECT :

URA KWUN TONG TOWN CENTRE
REDEVELOPMENT (AREA 2 & 3) AT NKIL 6514, KWUN TONG, KWLOON

3

TITLE : SHOP DRAWING FOR
CURTAIN WALL PERFORMANCE TEST SUBMISSION

DATE: 12- MAY- 2019

DRAWING SUBMISSION REGISTER

PROJECT : URA KWUN TONG TOWN CENTRE REDEVELOPMENT (AREA 2 & 3) AT NKIL 6514, KWUN TONG, KWLOON TITLE : SHOPDRAWING FOR CURTAIN WALL PERFORMANCE TEST	DATE OF ISSUE							SUBMISSION STATE (FOR B.D / A.S.D)	SUBMISSION STATE (FOR CLIENT / CONSULTANT)	SUBMISSION STATE (FOR ARCHITECT)	FABRICATION / CONSTRUCTION STATE												
	ISSUE	01	02	03	04	05	06	07	AP - APPROVED	AP - APPROVED	AP - APPROVED	ISSUE TO CHINA OFFICE		ISSUE TO SITE		ISSUE TO SUB-CONTRACTOR							
	DAY	10	26	30	20	02	17	12	AC - APPROVED SUB. TO CONDITION	AC - APPROVED SUB. TO CONDITION	AC - APPROVED SUB. TO CONDITION												
	MONTH	09	09	11	12	03	04	05	NA - NOT APPROVED	NA - NOT APPROVED	NA - NOT APPROVED												
	YEAR	18	18	18	18	19	19	19															
DRAWING TITLE	DWG. NO.	REVISIONS							COMMENT DATE	REV.	STATE	COMMENT DATE	REV.	STATE	COMMENT DATE	REV.	STATE	REV.	DATE	REV.	DATE	REV.	DATE
COVERPAGE	J837-PTCW-CP01	-	A	B	C	D	E	F															
DRAWING SUBMISSION REGISTER	J837-PTCW-DR01	-	A	B	C	D	E	F															
SECTION PROPERTIES OF CURTAIN WALL AT TOWER	J837-PTCW-ML01	-	-	A	A	A	A	A															
SECTION PROPERTIES OF CURTAIN WALL AT TOWER	J837-PTCW-ML02	-	A	A	B	B	B	B															
SECTION PROPERTIES OF CURTAIN WALL AT TOWER	J837-PTCW-ML03	-	A	A	B	B	C	C															
ELEVATION OF CURTAIN WALL AT TOWER	J837-PTCW-2101	-	A	B	C	D	E	F															
TYPICAL MULLION DETAIL FOR CURTAIN WALL AT TOWER	J837-PTCW-5001	-	-	A	A	A	A	A															
TYPICAL MULLION DETAIL FOR CURTAIN WALL AT TOWER	J837-PTCW-5002	-	-	A	A	A	A	A															
TYPICAL MULLION DETAIL FOR CURTAIN WALL AT TOWER	J837-PTCW-5003	-	A	B	B	C	C	C															
TYPICAL MULLION DETAIL FOR CURTAIN WALL AT TOWER	J837-PTCW-5004	-	A	B	B	C	C	C															
TYPICAL MULLION DETAIL FOR CURTAIN WALL AT TOWER	J837-PTCW-5005	-	-	-	-	-	-	-															
TYPICAL MULLION DETAIL FOR CURTAIN WALL AT TOWER	J837-PTCW-5006	-	-	-	-	-	A	A															
TYPICAL MULLION DETAIL FOR CURTAIN WALL AT TOWER	J837-PTCW-5007							-															
TYPICAL TRANSOM DETAIL FOR CURTAIN WALL AT TOWER	J837-PTCW-6001	-	A	B	C	D	D	E															
TYPICAL TRANSOM DETAIL FOR CURTAIN WALL AT TOWER	J837-PTCW-6002	-	A	B	C	D	D	D															
TYPICAL TRANSOM DETAIL FOR CURTAIN WALL AT TOWER	J837-PTCW-6003	-	A	B	B	B	C	C															
TYPICAL TRANSOM DETAIL FOR CURTAIN WALL AT TOWER	J837-PTCW-6004	-	-	A	A	A	A	A															
TYPICAL TRANSOM DETAIL FOR CURTAIN WALL AT TOWER	J837-PTCW-6005	-	A	B	B	C	C	C															
TYPICAL TRANSOM DETAIL FOR CURTAIN WALL AT TOWER	J837-PTCW-6006						-	A															

TOTAL PAGES :
(INCLUDING COVERPAGE AND DRAWING SUBMISSION REGISTER)

IN-HOUSE DESIGN CHECKER

美特鋁質有限公司
 MIDI ALUMINIUM FABRICATOR LTD.
 Units 6-8, Sunray Industrial Centre, 1/F
 610 Cha Kwo Ling Road, Kowloon
 Tel: 23489211-4 Fax: (852) 2727666

M1 --- ALUMINIUM MULLION GRADE --- 6063 T6	COATING --- PVF2 COATING	M2 --- ALUMINIUM MULLION GRADE --- 6063 T6	COATING --- PVF2 COATING	M3 --- ALUMINIUM MULLION GRADE --- 6063 T6	COATING --- PVF2 COATING	M5 --- ALUMINIUM MULLION GRADE --- 6063 T6	COATING --- PVF2 COATING	M6 --- ALUMINIUM MULLION GRADE --- 6063 T6	COATING --- PVF2 COATING																																																																																																																																																															
<table border="1"> <thead> <tr><th>MASS PROPERTIES (UNIT)</th><th>VALUES</th></tr> </thead> <tbody> <tr><td>Area (mm²):</td><td>2686.6</td></tr> <tr><td>Perimeter (mm):</td><td>1168.9</td></tr> <tr><td>Bounding Box - X (mm):</td><td>-45.0 to 45.0</td></tr> <tr><td>Bounding Box - Y (mm):</td><td>-90.7 to 84.3</td></tr> <tr><td>Centroid - X (mm):</td><td>0.0</td></tr> <tr><td>Centroid - Y (mm):</td><td>0.0</td></tr> <tr><td>Moments of inertia - X (mm⁴):</td><td>8560927.0</td></tr> <tr><td>Moments of inertia - Y (mm⁴):</td><td>3111287.7</td></tr> <tr><td>Product of inertia - XY (mm⁴):</td><td>0.0</td></tr> <tr><td>Radii of gyration - X (mm):</td><td>56.4</td></tr> <tr><td>Radii of gyration - Y (mm):</td><td>34.0</td></tr> <tr><td>Principal moments along X-Y (mm⁴):</td><td>8560927.0 along [1.0 0.0]</td></tr> <tr><td>Principal moments along Y-X (mm⁴):</td><td>3111287.7 along [0.0 1.0]</td></tr> <tr><td>Elastic Modulus - Zx (mm³):</td><td>1 / y-max= 94344.9</td></tr> <tr><td>Elastic Modulus - Zy (mm³):</td><td>J / x-max= 69139.7</td></tr> </tbody> </table>	MASS PROPERTIES (UNIT)	VALUES	Area (mm ²):	2686.6	Perimeter (mm):	1168.9	Bounding Box - X (mm):	-45.0 to 45.0	Bounding Box - Y (mm):	-90.7 to 84.3	Centroid - X (mm):	0.0	Centroid - Y (mm):	0.0	Moments of inertia - X (mm ⁴):	8560927.0	Moments of inertia - Y (mm ⁴):	3111287.7	Product of inertia - XY (mm ⁴):	0.0	Radii of gyration - X (mm):	56.4	Radii of gyration - Y (mm):	34.0	Principal moments along X-Y (mm ⁴):	8560927.0 along [1.0 0.0]	Principal moments along Y-X (mm ⁴):	3111287.7 along [0.0 1.0]	Elastic Modulus - Zx (mm ³):	1 / y-max= 94344.9	Elastic Modulus - Zy (mm ³):	J / x-max= 69139.7		<table border="1"> <thead> <tr><th>MASS PROPERTIES (UNIT)</th><th>VALUES</th></tr> </thead> <tbody> <tr><td>Area (mm²):</td><td>2560.0</td></tr> <tr><td>Perimeter (mm):</td><td>1002.9</td></tr> <tr><td>Bounding Box - X (mm):</td><td>-40.5 to 49.5</td></tr> <tr><td>Bounding Box - Y (mm):</td><td>-102.1 to 72.9</td></tr> <tr><td>Centroid - X (mm):</td><td>0.0</td></tr> <tr><td>Centroid - Y (mm):</td><td>0.0</td></tr> <tr><td>Moments of inertia - X (mm⁴):</td><td>7148090.8</td></tr> <tr><td>Moments of inertia - Y (mm⁴):</td><td>2693592.6</td></tr> <tr><td>Product of inertia - XY (mm⁴):</td><td>-858464.6</td></tr> <tr><td>Radii of gyration - X (mm):</td><td>52.8</td></tr> <tr><td>Radii of gyration - Y (mm):</td><td>32.4</td></tr> <tr><td>Principal moments along X-Y (mm⁴):</td><td>7307806.3 along [1.0 -0.2]</td></tr> <tr><td>Principal moments along Y-X (mm⁴):</td><td>2533877.1 along [0.2 1.0]</td></tr> <tr><td>Elastic Modulus - Zx (mm³):</td><td>1 / y-max= 69979.9</td></tr> <tr><td>Elastic Modulus - Zy (mm³):</td><td>J / x-max= 54419.8</td></tr> </tbody> </table>	MASS PROPERTIES (UNIT)	VALUES	Area (mm ²):	2560.0	Perimeter (mm):	1002.9	Bounding Box - X (mm):	-40.5 to 49.5	Bounding Box - Y (mm):	-102.1 to 72.9	Centroid - X (mm):	0.0	Centroid - Y (mm):	0.0	Moments of inertia - X (mm ⁴):	7148090.8	Moments of inertia - Y (mm ⁴):	2693592.6	Product of inertia - XY (mm ⁴):	-858464.6	Radii of gyration - X (mm):	52.8	Radii of gyration - Y (mm):	32.4	Principal moments along X-Y (mm ⁴):	7307806.3 along [1.0 -0.2]	Principal moments along Y-X (mm ⁴):	2533877.1 along [0.2 1.0]	Elastic Modulus - Zx (mm ³):	1 / y-max= 69979.9	Elastic Modulus - Zy (mm ³):	J / x-max= 54419.8		<table border="1"> <thead> <tr><th>MASS PROPERTIES (UNIT)</th><th>VALUES</th></tr> </thead> <tbody> <tr><td>Area (mm²):</td><td>2904.8</td></tr> <tr><td>Perimeter (mm):</td><td>845.0</td></tr> <tr><td>Bounding Box - X (mm):</td><td>-45.0 to 45.0</td></tr> <tr><td>Bounding Box - Y (mm):</td><td>-70.5 to 60.0</td></tr> <tr><td>Centroid - X (mm):</td><td>0.0</td></tr> <tr><td>Centroid - Y (mm):</td><td>0.0</td></tr> <tr><td>Moments of inertia - X (mm⁴):</td><td>5525541.9</td></tr> <tr><td>Moments of inertia - Y (mm⁴):</td><td>2552618.8</td></tr> <tr><td>Product of inertia - XY (mm⁴):</td><td>0.0</td></tr> <tr><td>Radii of gyration - X (mm):</td><td>43.6</td></tr> <tr><td>Radii of gyration - Y (mm):</td><td>29.6</td></tr> <tr><td>Principal moments along X-Y (mm⁴):</td><td>5525541.9 along [1.0 0.0]</td></tr> <tr><td>Principal moments along Y-X (mm⁴):</td><td>2552618.8 along [0.0 1.0]</td></tr> <tr><td>Elastic Modulus - Zx (mm³):</td><td>1 / y-max= 78397.1</td></tr> <tr><td>Elastic Modulus - Zy (mm³):</td><td>J / x-max= 56724.9</td></tr> </tbody> </table>	MASS PROPERTIES (UNIT)	VALUES	Area (mm ²):	2904.8	Perimeter (mm):	845.0	Bounding Box - X (mm):	-45.0 to 45.0	Bounding Box - Y (mm):	-70.5 to 60.0	Centroid - X (mm):	0.0	Centroid - Y (mm):	0.0	Moments of inertia - X (mm ⁴):	5525541.9	Moments of inertia - Y (mm ⁴):	2552618.8	Product of inertia - XY (mm ⁴):	0.0	Radii of gyration - X (mm):	43.6	Radii of gyration - Y (mm):	29.6	Principal moments along X-Y (mm ⁴):	5525541.9 along [1.0 0.0]	Principal moments along Y-X (mm ⁴):	2552618.8 along [0.0 1.0]	Elastic Modulus - Zx (mm ³):	1 / y-max= 78397.1	Elastic Modulus - Zy (mm ³):	J / x-max= 56724.9		<table border="1"> <thead> <tr><th>MASS PROPERTIES (UNIT)</th><th>VALUES</th></tr> </thead> <tbody> <tr><td>Area (mm²):</td><td>4006.3</td></tr> <tr><td>Perimeter (mm):</td><td>1633.1</td></tr> <tr><td>Bounding Box - X (mm):</td><td>-75.7 to 56.3</td></tr> <tr><td>Bounding Box - Y (mm):</td><td>-100.1 to 115.3</td></tr> <tr><td>Centroid - X (mm):</td><td>0.0</td></tr> <tr><td>Centroid - Y (mm):</td><td>0.0</td></tr> <tr><td>Moments of inertia - X (mm⁴):</td><td>17546808.7</td></tr> <tr><td>Moments of inertia - Y (mm⁴):</td><td>5955158.6</td></tr> <tr><td>Product of inertia - XY (mm⁴):</td><td>-1928247.4</td></tr> <tr><td>Radii of gyration - X (mm):</td><td>66.2</td></tr> <tr><td>Radii of gyration - Y (mm):</td><td>38.6</td></tr> <tr><td>Principal moments along X-Y (mm⁴):</td><td>17859152.5 along [1.0 -0.2]</td></tr> <tr><td>Principal moments along Y-X (mm⁴):</td><td>5642814.9 along [0.2 1.0]</td></tr> <tr><td>Elastic Modulus - Zx (mm³):</td><td>1 / y-max= 152220.1</td></tr> <tr><td>Elastic Modulus - Zy (mm³):</td><td>J / x-max= 78715.3</td></tr> </tbody> </table>	MASS PROPERTIES (UNIT)	VALUES	Area (mm ²):	4006.3	Perimeter (mm):	1633.1	Bounding Box - X (mm):	-75.7 to 56.3	Bounding Box - Y (mm):	-100.1 to 115.3	Centroid - X (mm):	0.0	Centroid - Y (mm):	0.0	Moments of inertia - X (mm ⁴):	17546808.7	Moments of inertia - Y (mm ⁴):	5955158.6	Product of inertia - XY (mm ⁴):	-1928247.4	Radii of gyration - X (mm):	66.2	Radii of gyration - Y (mm):	38.6	Principal moments along X-Y (mm ⁴):	17859152.5 along [1.0 -0.2]	Principal moments along Y-X (mm ⁴):	5642814.9 along [0.2 1.0]	Elastic Modulus - Zx (mm ³):	1 / y-max= 152220.1	Elastic Modulus - Zy (mm ³):	J / x-max= 78715.3		<table border="1"> <thead> <tr><th>MASS PROPERTIES (UNIT)</th><th>VALUES</th></tr> </thead> <tbody> <tr><td>Area (mm²):</td><td>2278.1</td></tr> <tr><td>Perimeter (mm):</td><td>895.8</td></tr> <tr><td>Bounding Box - X (mm):</td><td>-45.0 to 45.0</td></tr> <tr><td>Bounding Box - Y (mm):</td><td>-69.4 to 61.1</td></tr> <tr><td>Centroid - X (mm):</td><td>0.0</td></tr> <tr><td>Centroid - Y (mm):</td><td>0.0</td></tr> <tr><td>Moments of inertia - X (mm⁴):</td><td>4229062.4</td></tr> <tr><td>Moments of inertia - Y (mm⁴):</td><td>2263514.5</td></tr> <tr><td>Product of inertia - XY (mm⁴):</td><td>0.0</td></tr> <tr><td>Radii of gyration - X (mm):</td><td>43.1</td></tr> <tr><td>Radii of gyration - Y (mm):</td><td>31.5</td></tr> <tr><td>Principal moments along X-Y (mm⁴):</td><td>4229062.4 along [1.0 0.0]</td></tr> <tr><td>Principal moments along Y-X (mm⁴):</td><td>2263514.5 along [0.0 1.0]</td></tr> <tr><td>Elastic Modulus - Zx (mm³):</td><td>1 / y-max= 60912.9</td></tr> <tr><td>Elastic Modulus - Zy (mm³):</td><td>J / x-max= 50300.3</td></tr> </tbody> </table>	MASS PROPERTIES (UNIT)	VALUES	Area (mm ²):	2278.1	Perimeter (mm):	895.8	Bounding Box - X (mm):	-45.0 to 45.0	Bounding Box - Y (mm):	-69.4 to 61.1	Centroid - X (mm):	0.0	Centroid - Y (mm):	0.0	Moments of inertia - X (mm ⁴):	4229062.4	Moments of inertia - Y (mm ⁴):	2263514.5	Product of inertia - XY (mm ⁴):	0.0	Radii of gyration - X (mm):	43.1	Radii of gyration - Y (mm):	31.5	Principal moments along X-Y (mm ⁴):	4229062.4 along [1.0 0.0]	Principal moments along Y-X (mm ⁴):	2263514.5 along [0.0 1.0]	Elastic Modulus - Zx (mm ³):	1 / y-max= 60912.9	Elastic Modulus - Zy (mm ³):	J / x-max= 50300.3
MASS PROPERTIES (UNIT)	VALUES																																																																																																																																																																							
Area (mm ²):	2686.6																																																																																																																																																																							
Perimeter (mm):	1168.9																																																																																																																																																																							
Bounding Box - X (mm):	-45.0 to 45.0																																																																																																																																																																							
Bounding Box - Y (mm):	-90.7 to 84.3																																																																																																																																																																							
Centroid - X (mm):	0.0																																																																																																																																																																							
Centroid - Y (mm):	0.0																																																																																																																																																																							
Moments of inertia - X (mm ⁴):	8560927.0																																																																																																																																																																							
Moments of inertia - Y (mm ⁴):	3111287.7																																																																																																																																																																							
Product of inertia - XY (mm ⁴):	0.0																																																																																																																																																																							
Radii of gyration - X (mm):	56.4																																																																																																																																																																							
Radii of gyration - Y (mm):	34.0																																																																																																																																																																							
Principal moments along X-Y (mm ⁴):	8560927.0 along [1.0 0.0]																																																																																																																																																																							
Principal moments along Y-X (mm ⁴):	3111287.7 along [0.0 1.0]																																																																																																																																																																							
Elastic Modulus - Zx (mm ³):	1 / y-max= 94344.9																																																																																																																																																																							
Elastic Modulus - Zy (mm ³):	J / x-max= 69139.7																																																																																																																																																																							
MASS PROPERTIES (UNIT)	VALUES																																																																																																																																																																							
Area (mm ²):	2560.0																																																																																																																																																																							
Perimeter (mm):	1002.9																																																																																																																																																																							
Bounding Box - X (mm):	-40.5 to 49.5																																																																																																																																																																							
Bounding Box - Y (mm):	-102.1 to 72.9																																																																																																																																																																							
Centroid - X (mm):	0.0																																																																																																																																																																							
Centroid - Y (mm):	0.0																																																																																																																																																																							
Moments of inertia - X (mm ⁴):	7148090.8																																																																																																																																																																							
Moments of inertia - Y (mm ⁴):	2693592.6																																																																																																																																																																							
Product of inertia - XY (mm ⁴):	-858464.6																																																																																																																																																																							
Radii of gyration - X (mm):	52.8																																																																																																																																																																							
Radii of gyration - Y (mm):	32.4																																																																																																																																																																							
Principal moments along X-Y (mm ⁴):	7307806.3 along [1.0 -0.2]																																																																																																																																																																							
Principal moments along Y-X (mm ⁴):	2533877.1 along [0.2 1.0]																																																																																																																																																																							
Elastic Modulus - Zx (mm ³):	1 / y-max= 69979.9																																																																																																																																																																							
Elastic Modulus - Zy (mm ³):	J / x-max= 54419.8																																																																																																																																																																							
MASS PROPERTIES (UNIT)	VALUES																																																																																																																																																																							
Area (mm ²):	2904.8																																																																																																																																																																							
Perimeter (mm):	845.0																																																																																																																																																																							
Bounding Box - X (mm):	-45.0 to 45.0																																																																																																																																																																							
Bounding Box - Y (mm):	-70.5 to 60.0																																																																																																																																																																							
Centroid - X (mm):	0.0																																																																																																																																																																							
Centroid - Y (mm):	0.0																																																																																																																																																																							
Moments of inertia - X (mm ⁴):	5525541.9																																																																																																																																																																							
Moments of inertia - Y (mm ⁴):	2552618.8																																																																																																																																																																							
Product of inertia - XY (mm ⁴):	0.0																																																																																																																																																																							
Radii of gyration - X (mm):	43.6																																																																																																																																																																							
Radii of gyration - Y (mm):	29.6																																																																																																																																																																							
Principal moments along X-Y (mm ⁴):	5525541.9 along [1.0 0.0]																																																																																																																																																																							
Principal moments along Y-X (mm ⁴):	2552618.8 along [0.0 1.0]																																																																																																																																																																							
Elastic Modulus - Zx (mm ³):	1 / y-max= 78397.1																																																																																																																																																																							
Elastic Modulus - Zy (mm ³):	J / x-max= 56724.9																																																																																																																																																																							
MASS PROPERTIES (UNIT)	VALUES																																																																																																																																																																							
Area (mm ²):	4006.3																																																																																																																																																																							
Perimeter (mm):	1633.1																																																																																																																																																																							
Bounding Box - X (mm):	-75.7 to 56.3																																																																																																																																																																							
Bounding Box - Y (mm):	-100.1 to 115.3																																																																																																																																																																							
Centroid - X (mm):	0.0																																																																																																																																																																							
Centroid - Y (mm):	0.0																																																																																																																																																																							
Moments of inertia - X (mm ⁴):	17546808.7																																																																																																																																																																							
Moments of inertia - Y (mm ⁴):	5955158.6																																																																																																																																																																							
Product of inertia - XY (mm ⁴):	-1928247.4																																																																																																																																																																							
Radii of gyration - X (mm):	66.2																																																																																																																																																																							
Radii of gyration - Y (mm):	38.6																																																																																																																																																																							
Principal moments along X-Y (mm ⁴):	17859152.5 along [1.0 -0.2]																																																																																																																																																																							
Principal moments along Y-X (mm ⁴):	5642814.9 along [0.2 1.0]																																																																																																																																																																							
Elastic Modulus - Zx (mm ³):	1 / y-max= 152220.1																																																																																																																																																																							
Elastic Modulus - Zy (mm ³):	J / x-max= 78715.3																																																																																																																																																																							
MASS PROPERTIES (UNIT)	VALUES																																																																																																																																																																							
Area (mm ²):	2278.1																																																																																																																																																																							
Perimeter (mm):	895.8																																																																																																																																																																							
Bounding Box - X (mm):	-45.0 to 45.0																																																																																																																																																																							
Bounding Box - Y (mm):	-69.4 to 61.1																																																																																																																																																																							
Centroid - X (mm):	0.0																																																																																																																																																																							
Centroid - Y (mm):	0.0																																																																																																																																																																							
Moments of inertia - X (mm ⁴):	4229062.4																																																																																																																																																																							
Moments of inertia - Y (mm ⁴):	2263514.5																																																																																																																																																																							
Product of inertia - XY (mm ⁴):	0.0																																																																																																																																																																							
Radii of gyration - X (mm):	43.1																																																																																																																																																																							
Radii of gyration - Y (mm):	31.5																																																																																																																																																																							
Principal moments along X-Y (mm ⁴):	4229062.4 along [1.0 0.0]																																																																																																																																																																							
Principal moments along Y-X (mm ⁴):	2263514.5 along [0.0 1.0]																																																																																																																																																																							
Elastic Modulus - Zx (mm ³):	1 / y-max= 60912.9																																																																																																																																																																							
Elastic Modulus - Zy (mm ³):	J / x-max= 50300.3																																																																																																																																																																							

T1 --- ALUMINIUM TRANSOM GRADE --- 6063 T6	COATING --- PVF2 COATING	T2 --- ALUMINIUM TRANSOM GRADE --- 6063 T6	COATING --- PVF2 COATING	A01 --- ALUMINIUM CAP GRADE --- 6063 T5	COATING --- PVF2 COATING	A02 --- ALUMINIUM WINDOW SASH GRADE --- 6063 T6	COATING --- PVF2 COATING	A03 --- ALUMINIUM CAPPING GRADE --- 6063 T6	COATING --- PVF2 COATING																																																																																																																																																															
<table border="1"> <thead> <tr><th>MASS PROPERTIES (UNIT)</th><th>VALUES</th></tr> </thead> <tbody> <tr><td>Area (mm²):</td><td>2283.2</td></tr> <tr><td>Perimeter (mm):</td><td>1446.4</td></tr> <tr><td>Bounding Box - X (mm):</td><td>-88.5 to 95.5</td></tr> <tr><td>Bounding Box - Y (mm):</td><td>-48.5 to 41.5</td></tr> <tr><td>Centroid - X (mm):</td><td>0.0</td></tr> <tr><td>Centroid - Y (mm):</td><td>0.0</td></tr> <tr><td>Moments of inertia - X (mm⁴):</td><td>1841389.3</td></tr> <tr><td>Moments of inertia - Y (mm⁴):</td><td>8107752.5</td></tr> <tr><td>Product of inertia - XY (mm⁴):</td><td>-388294.0</td></tr> <tr><td>Radii of gyration - X (mm):</td><td>28.4</td></tr> <tr><td>Radii of gyration - Y (mm):</td><td>59.6</td></tr> <tr><td>Principal moments along X-Y (mm⁴):</td><td>1817420.4 along [1.0 0.1]</td></tr> <tr><td>Principal moments along Y-X (mm⁴):</td><td>8131721.4 along [-0.1 1.0]</td></tr> <tr><td>Elastic Modulus - Zx (mm³):</td><td>1 / y-max= 37934.0</td></tr> <tr><td>Elastic Modulus - Zy (mm³):</td><td>J / x-max= 84907.9</td></tr> </tbody> </table>	MASS PROPERTIES (UNIT)	VALUES	Area (mm ²):	2283.2	Perimeter (mm):	1446.4	Bounding Box - X (mm):	-88.5 to 95.5	Bounding Box - Y (mm):	-48.5 to 41.5	Centroid - X (mm):	0.0	Centroid - Y (mm):	0.0	Moments of inertia - X (mm ⁴):	1841389.3	Moments of inertia - Y (mm ⁴):	8107752.5	Product of inertia - XY (mm ⁴):	-388294.0	Radii of gyration - X (mm):	28.4	Radii of gyration - Y (mm):	59.6	Principal moments along X-Y (mm ⁴):	1817420.4 along [1.0 0.1]	Principal moments along Y-X (mm ⁴):	8131721.4 along [-0.1 1.0]	Elastic Modulus - Zx (mm ³):	1 / y-max= 37934.0	Elastic Modulus - Zy (mm ³):	J / x-max= 84907.9		<table border="1"> <thead> <tr><th>MASS PROPERTIES (UNIT)</th><th>VALUES</th></tr> </thead> <tbody> <tr><td>Area (mm²):</td><td>1969.2</td></tr> <tr><td>Perimeter (mm):</td><td>1203.5</td></tr> <tr><td>Bounding Box - X (mm):</td><td>-100.8 to 83.2</td></tr> <tr><td>Bounding Box - Y (mm):</td><td>-42.9 to 47.1</td></tr> <tr><td>Centroid - X (mm):</td><td>0.0</td></tr> <tr><td>Centroid - Y (mm):</td><td>0.0</td></tr> <tr><td>Moments of inertia - X (mm⁴):</td><td>1401920.1</td></tr> <tr><td>Moments of inertia - Y (mm⁴):</td><td>6039676.5</td></tr> <tr><td>Product of inertia - XY (mm⁴):</td><td>1059596.3</td></tr> <tr><td>Radii of gyration - X (mm):</td><td>26.7</td></tr> <tr><td>Radii of gyration - Y (mm):</td><td>55.4</td></tr> <tr><td>Principal moments along X-Y (mm⁴):</td><td>1171300.2 along [1.0 0.2]</td></tr> <tr><td>Principal moments along Y-X (mm⁴):</td><td>6270296.4 along [-0.2 1.0]</td></tr> <tr><td>Elastic Modulus - Zx (mm³):</td><td>1 / y-max= 29761.3</td></tr> <tr><td>Elastic Modulus - Zy (mm³):</td><td>J / x-max= 59896.7</td></tr> </tbody> </table>	MASS PROPERTIES (UNIT)	VALUES	Area (mm ²):	1969.2	Perimeter (mm):	1203.5	Bounding Box - X (mm):	-100.8 to 83.2	Bounding Box - Y (mm):	-42.9 to 47.1	Centroid - X (mm):	0.0	Centroid - Y (mm):	0.0	Moments of inertia - X (mm ⁴):	1401920.1	Moments of inertia - Y (mm ⁴):	6039676.5	Product of inertia - XY (mm ⁴):	1059596.3	Radii of gyration - X (mm):	26.7	Radii of gyration - Y (mm):	55.4	Principal moments along X-Y (mm ⁴):	1171300.2 along [1.0 0.2]	Principal moments along Y-X (mm ⁴):	6270296.4 along [-0.2 1.0]	Elastic Modulus - Zx (mm ³):	1 / y-max= 29761.3	Elastic Modulus - Zy (mm ³):	J / x-max= 59896.7		<table border="1"> <thead> <tr><th>MASS PROPERTIES (UNIT)</th><th>VALUES</th></tr> </thead> <tbody> <tr><td>Area (mm²):</td><td>132.6</td></tr> <tr><td>Perimeter (mm):</td><td>194.5</td></tr> <tr><td>Bounding Box - X (mm):</td><td>-44.7 to 45.9</td></tr> <tr><td>Bounding Box - Y (mm):</td><td>-3.1 to 0.8</td></tr> <tr><td>Centroid - X (mm):</td><td>0.0</td></tr> <tr><td>Centroid - Y (mm):</td><td>0.0</td></tr> <tr><td>Moments of inertia - X (mm⁴):</td><td>51.8</td></tr> <tr><td>Moments of inertia - Y (mm⁴):</td><td>96748.1</td></tr> <tr><td>Product of inertia - XY (mm⁴):</td><td>118.1</td></tr> <tr><td>Radii of gyration - X (mm):</td><td>0.6</td></tr> <tr><td>Radii of gyration - Y (mm):</td><td>27.0</td></tr> <tr><td>Principal moments along X-Y (mm⁴):</td><td>51.7 along [1.0 0.0]</td></tr> <tr><td>Principal moments along Y-X (mm⁴):</td><td>96748.3 along [0.0 1.0]</td></tr> <tr><td>Elastic Modulus - Zx (mm³):</td><td>1 / y-max= 16.6</td></tr> <tr><td>Elastic Modulus - Zy (mm³):</td><td>J / x-max= 2107.2</td></tr> </tbody> </table>	MASS PROPERTIES (UNIT)	VALUES	Area (mm ²):	132.6	Perimeter (mm):	194.5	Bounding Box - X (mm):	-44.7 to 45.9	Bounding Box - Y (mm):	-3.1 to 0.8	Centroid - X (mm):	0.0	Centroid - Y (mm):	0.0	Moments of inertia - X (mm ⁴):	51.8	Moments of inertia - Y (mm ⁴):	96748.1	Product of inertia - XY (mm ⁴):	118.1	Radii of gyration - X (mm):	0.6	Radii of gyration - Y (mm):	27.0	Principal moments along X-Y (mm ⁴):	51.7 along [1.0 0.0]	Principal moments along Y-X (mm ⁴):	96748.3 along [0.0 1.0]	Elastic Modulus - Zx (mm ³):	1 / y-max= 16.6	Elastic Modulus - Zy (mm ³):	J / x-max= 2107.2		<table border="1"> <thead> <tr><th>MASS PROPERTIES (UNIT)</th><th>VALUES</th></tr> </thead> <tbody> <tr><td>Area (mm²):</td><td>673.8</td></tr> <tr><td>Perimeter (mm):</td><td>465.0</td></tr> <tr><td>Bounding Box - X (mm):</td><td>-22.3 to 15.2</td></tr> <tr><td>Bounding Box - Y (mm):</td><td>-37.3 to 40.7</td></tr> <tr><td>Centroid - X (mm):</td><td>0.0</td></tr> <tr><td>Centroid - Y (mm):</td><td>0.0</td></tr> <tr><td>Moments of inertia - X (mm⁴):</td><td>287162.6</td></tr> <tr><td>Moments of inertia - Y (mm⁴):</td><td>88704.2</td></tr> <tr><td>Product of inertia - XY (mm⁴):</td><td>-87527.0</td></tr> <tr><td>Radii of gyration - X (mm):</td><td>20.6</td></tr> <tr><td>Radii of gyration - Y (mm):</td><td>11.5</td></tr> <tr><td>Principal moments along X-Y (mm⁴):</td><td>320249.0 along [0.9 -0.4]</td></tr> <tr><td>Principal moments along Y-X (mm⁴):</td><td>55617.8 along [0.4 0.9]</td></tr> <tr><td>Elastic Modulus - Zx (mm³):</td><td>1 / y-max= 7060.2</td></tr> <tr><td>Elastic Modulus - Zy (mm³):</td><td>J / x-max= 3982.3</td></tr> </tbody> </table>	MASS PROPERTIES (UNIT)	VALUES	Area (mm ²):	673.8	Perimeter (mm):	465.0	Bounding Box - X (mm):	-22.3 to 15.2	Bounding Box - Y (mm):	-37.3 to 40.7	Centroid - X (mm):	0.0	Centroid - Y (mm):	0.0	Moments of inertia - X (mm ⁴):	287162.6	Moments of inertia - Y (mm ⁴):	88704.2	Product of inertia - XY (mm ⁴):	-87527.0	Radii of gyration - X (mm):	20.6	Radii of gyration - Y (mm):	11.5	Principal moments along X-Y (mm ⁴):	320249.0 along [0.9 -0.4]	Principal moments along Y-X (mm ⁴):	55617.8 along [0.4 0.9]	Elastic Modulus - Zx (mm ³):	1 / y-max= 7060.2	Elastic Modulus - Zy (mm ³):	J / x-max= 3982.3		<table border="1"> <thead> <tr><th>MASS PROPERTIES (UNIT)</th><th>VALUES</th></tr> </thead> <tbody> <tr><td>Area (mm²):</td><td>304.6</td></tr> <tr><td>Perimeter (mm):</td><td>199.5</td></tr> <tr><td>Bounding Box - X (mm):</td><td>-10.4 to 27.1</td></tr> <tr><td>Bounding Box - Y (mm):</td><td>-14.5 to 25.5</td></tr> <tr><td>Centroid - X (mm):</td><td>0.0</td></tr> <tr><td>Centroid - Y (mm):</td><td>0.0</td></tr> <tr><td>Moments of inertia - X (mm⁴):</td><td>56645.9</td></tr> <tr><td>Moments of inertia - Y (mm⁴):</td><td>36421.8</td></tr> <tr><td>Product of inertia - XY (mm⁴):</td><td>-25163.9</td></tr> <tr><td>Radii of gyration - X (mm):</td><td>13.6</td></tr> <tr><td>Radii of gyration - Y (mm):</td><td>10.9</td></tr> <tr><td>Principal moments along X-Y (mm⁴):</td><td>19414.2 along [0.6 -0.8]</td></tr> <tr><td>Principal moments along Y-X (mm⁴):</td><td>73653.5 along [0.8 0.6]</td></tr> <tr><td>Elastic Modulus - Zx (mm³):</td><td>1 / y-max= 2224.1</td></tr> <tr><td>Elastic Modulus - Zy (mm³):</td><td>J / x-max= 1346.3</td></tr> </tbody> </table>	MASS PROPERTIES (UNIT)	VALUES	Area (mm ²):	304.6	Perimeter (mm):	199.5	Bounding Box - X (mm):	-10.4 to 27.1	Bounding Box - Y (mm):	-14.5 to 25.5	Centroid - X (mm):	0.0	Centroid - Y (mm):	0.0	Moments of inertia - X (mm ⁴):	56645.9	Moments of inertia - Y (mm ⁴):	36421.8	Product of inertia - XY (mm ⁴):	-25163.9	Radii of gyration - X (mm):	13.6	Radii of gyration - Y (mm):	10.9	Principal moments along X-Y (mm ⁴):	19414.2 along [0.6 -0.8]	Principal moments along Y-X (mm ⁴):	73653.5 along [0.8 0.6]	Elastic Modulus - Zx (mm ³):	1 / y-max= 2224.1	Elastic Modulus - Zy (mm ³):	J / x-max= 1346.3
MASS PROPERTIES (UNIT)	VALUES																																																																																																																																																																							
Area (mm ²):	2283.2																																																																																																																																																																							
Perimeter (mm):	1446.4																																																																																																																																																																							
Bounding Box - X (mm):	-88.5 to 95.5																																																																																																																																																																							
Bounding Box - Y (mm):	-48.5 to 41.5																																																																																																																																																																							
Centroid - X (mm):	0.0																																																																																																																																																																							
Centroid - Y (mm):	0.0																																																																																																																																																																							
Moments of inertia - X (mm ⁴):	1841389.3																																																																																																																																																																							
Moments of inertia - Y (mm ⁴):	8107752.5																																																																																																																																																																							
Product of inertia - XY (mm ⁴):	-388294.0																																																																																																																																																																							
Radii of gyration - X (mm):	28.4																																																																																																																																																																							
Radii of gyration - Y (mm):	59.6																																																																																																																																																																							
Principal moments along X-Y (mm ⁴):	1817420.4 along [1.0 0.1]																																																																																																																																																																							
Principal moments along Y-X (mm ⁴):	8131721.4 along [-0.1 1.0]																																																																																																																																																																							
Elastic Modulus - Zx (mm ³):	1 / y-max= 37934.0																																																																																																																																																																							
Elastic Modulus - Zy (mm ³):	J / x-max= 84907.9																																																																																																																																																																							
MASS PROPERTIES (UNIT)	VALUES																																																																																																																																																																							
Area (mm ²):	1969.2																																																																																																																																																																							
Perimeter (mm):	1203.5																																																																																																																																																																							
Bounding Box - X (mm):	-100.8 to 83.2																																																																																																																																																																							
Bounding Box - Y (mm):	-42.9 to 47.1																																																																																																																																																																							
Centroid - X (mm):	0.0																																																																																																																																																																							
Centroid - Y (mm):	0.0																																																																																																																																																																							
Moments of inertia - X (mm ⁴):	1401920.1																																																																																																																																																																							
Moments of inertia - Y (mm ⁴):	6039676.5																																																																																																																																																																							
Product of inertia - XY (mm ⁴):	1059596.3																																																																																																																																																																							
Radii of gyration - X (mm):	26.7																																																																																																																																																																							
Radii of gyration - Y (mm):	55.4																																																																																																																																																																							
Principal moments along X-Y (mm ⁴):	1171300.2 along [1.0 0.2]																																																																																																																																																																							
Principal moments along Y-X (mm ⁴):	6270296.4 along [-0.2 1.0]																																																																																																																																																																							
Elastic Modulus - Zx (mm ³):	1 / y-max= 29761.3																																																																																																																																																																							
Elastic Modulus - Zy (mm ³):	J / x-max= 59896.7																																																																																																																																																																							
MASS PROPERTIES (UNIT)	VALUES																																																																																																																																																																							
Area (mm ²):	132.6																																																																																																																																																																							
Perimeter (mm):	194.5																																																																																																																																																																							
Bounding Box - X (mm):	-44.7 to 45.9																																																																																																																																																																							
Bounding Box - Y (mm):	-3.1 to 0.8																																																																																																																																																																							
Centroid - X (mm):	0.0																																																																																																																																																																							
Centroid - Y (mm):	0.0																																																																																																																																																																							
Moments of inertia - X (mm ⁴):	51.8																																																																																																																																																																							
Moments of inertia - Y (mm ⁴):	96748.1																																																																																																																																																																							
Product of inertia - XY (mm ⁴):	118.1																																																																																																																																																																							
Radii of gyration - X (mm):	0.6																																																																																																																																																																							
Radii of gyration - Y (mm):	27.0																																																																																																																																																																							
Principal moments along X-Y (mm ⁴):	51.7 along [1.0 0.0]																																																																																																																																																																							
Principal moments along Y-X (mm ⁴):	96748.3 along [0.0 1.0]																																																																																																																																																																							
Elastic Modulus - Zx (mm ³):	1 / y-max= 16.6																																																																																																																																																																							
Elastic Modulus - Zy (mm ³):	J / x-max= 2107.2																																																																																																																																																																							
MASS PROPERTIES (UNIT)	VALUES																																																																																																																																																																							
Area (mm ²):	673.8																																																																																																																																																																							
Perimeter (mm):	465.0																																																																																																																																																																							
Bounding Box - X (mm):	-22.3 to 15.2																																																																																																																																																																							
Bounding Box - Y (mm):	-37.3 to 40.7																																																																																																																																																																							
Centroid - X (mm):	0.0																																																																																																																																																																							
Centroid - Y (mm):	0.0																																																																																																																																																																							
Moments of inertia - X (mm ⁴):	287162.6																																																																																																																																																																							
Moments of inertia - Y (mm ⁴):	88704.2																																																																																																																																																																							
Product of inertia - XY (mm ⁴):	-87527.0																																																																																																																																																																							
Radii of gyration - X (mm):	20.6																																																																																																																																																																							
Radii of gyration - Y (mm):	11.5																																																																																																																																																																							
Principal moments along X-Y (mm ⁴):	320249.0 along [0.9 -0.4]																																																																																																																																																																							
Principal moments along Y-X (mm ⁴):	55617.8 along [0.4 0.9]																																																																																																																																																																							
Elastic Modulus - Zx (mm ³):	1 / y-max= 7060.2																																																																																																																																																																							
Elastic Modulus - Zy (mm ³):	J / x-max= 3982.3																																																																																																																																																																							
MASS PROPERTIES (UNIT)	VALUES																																																																																																																																																																							
Area (mm ²):	304.6																																																																																																																																																																							
Perimeter (mm):	199.5																																																																																																																																																																							
Bounding Box - X (mm):	-10.4 to 27.1																																																																																																																																																																							
Bounding Box - Y (mm):	-14.5 to 25.5																																																																																																																																																																							
Centroid - X (mm):	0.0																																																																																																																																																																							
Centroid - Y (mm):	0.0																																																																																																																																																																							
Moments of inertia - X (mm ⁴):	56645.9																																																																																																																																																																							
Moments of inertia - Y (mm ⁴):	36421.8																																																																																																																																																																							
Product of inertia - XY (mm ⁴):	-25163.9																																																																																																																																																																							
Radii of gyration - X (mm):	13.6																																																																																																																																																																							
Radii of gyration - Y (mm):	10.9																																																																																																																																																																							
Principal moments along X-Y (mm ⁴):	19414.2 along [0.6 -0.8]																																																																																																																																																																							
Principal moments along Y-X (mm ⁴):	73653.5 along [0.8 0.6]																																																																																																																																																																							
Elastic Modulus - Zx (mm ³):	1 / y-max= 2224.1																																																																																																																																																																							
Elastic Modulus - Zy (mm ³):	J / x-max= 1346.3																																																																																																																																																																							

B.D. REF :

CLIENT :
 信和置業有限公司
 Sino Land Company Limited

ARCHITECT :
 WONG TUNG & PARTNERS LIMITED
 ARCHITECTS & PLANNERS

MAIN CONTRACTOR :
 CR Construction Company Limited

STRUCTURAL ENGINEER :
 AECOM

FAÇADE CONSULTANT:
 AECOM

NOTE :
 1. ALL DIMENSIONS ARE IN mm.
 2. ALL ELEVATIONS ARE VIEWED FROM OUTSIDE.
 3. ALL DIMENSIONS TO BE VERIFIED ON SITE BEFORE FABRICATION.

LEGEND :
 X1 --- DETAIL MARK NO.
 X001 --- REFER SHEET NO.

1. F.F.L. --- FINISHED FLOOR LEVEL
 2. S.F.L. --- STRUCTURAL FLOOR LEVEL
 3. (R) --- REVERSED DETAIL

A	30/11/2018	GENERAL REVISED
NO.	DATE	REVISED BY

JOB NO. : J-837
 PROJECT :
 URA KWUN TONG TOWN CENTRE
 REDEVELOPMENT (AREA 2 & 3) AT
 NKIL 6514, KWUN TONG, KWLOON

TITLE :
 TYPICAL MULLION DETAIL
 FOR CURTAIN WALL
 PERFORMANCE TEST

DATE : 10-SEP-18 SCALE : 1:2 (A1)
 DRAWN BY : ASING CHECKED BY : -

美特鋁質有限公司
 MIDI ALUMINIUM FABRICATOR LTD.
 Units 6-8, Sunray Industrial Centre, 1/F
 610 Cha Kwo Ling Road, Kowloon
 Tel:23489211-4 Fax:(852)2727666

DWG NO. : JB37-PTCW-ML01 REV. : A

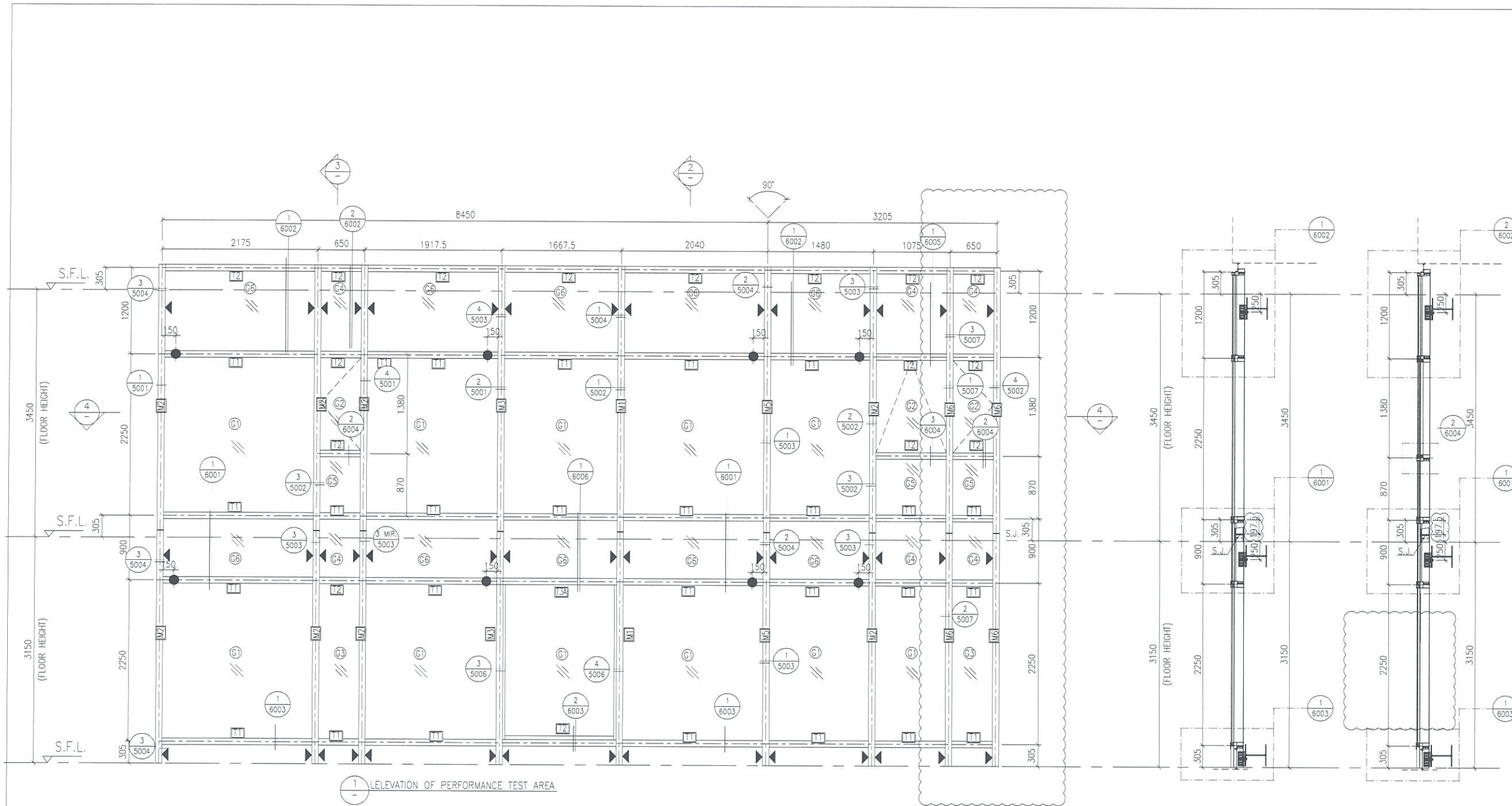

1 ELEVATION OF PERFORMANCE TEST AREA

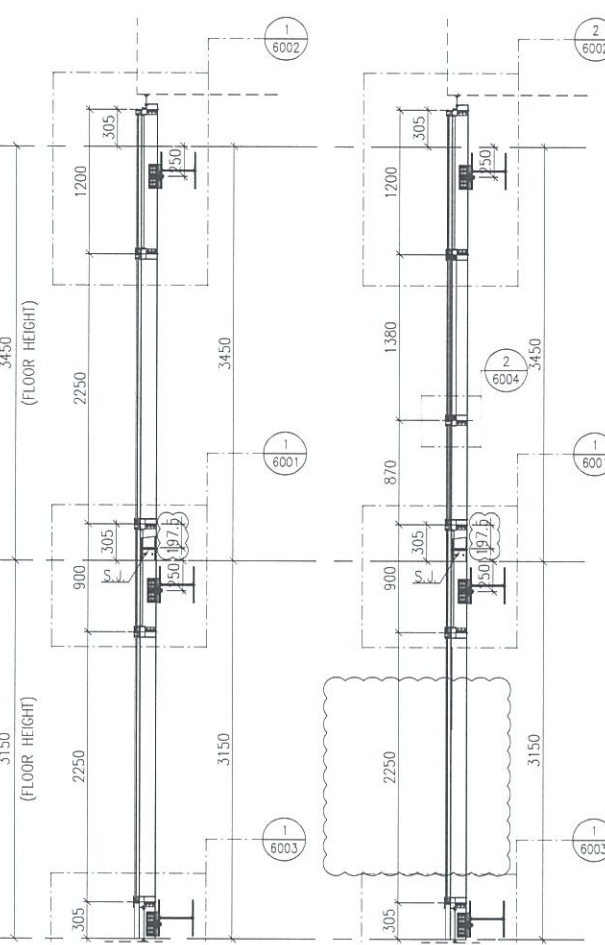

2 TYPICAL SECTION FOR CURTAIN WALL

3 TYPICAL SECTION FOR CURTAIN WALL

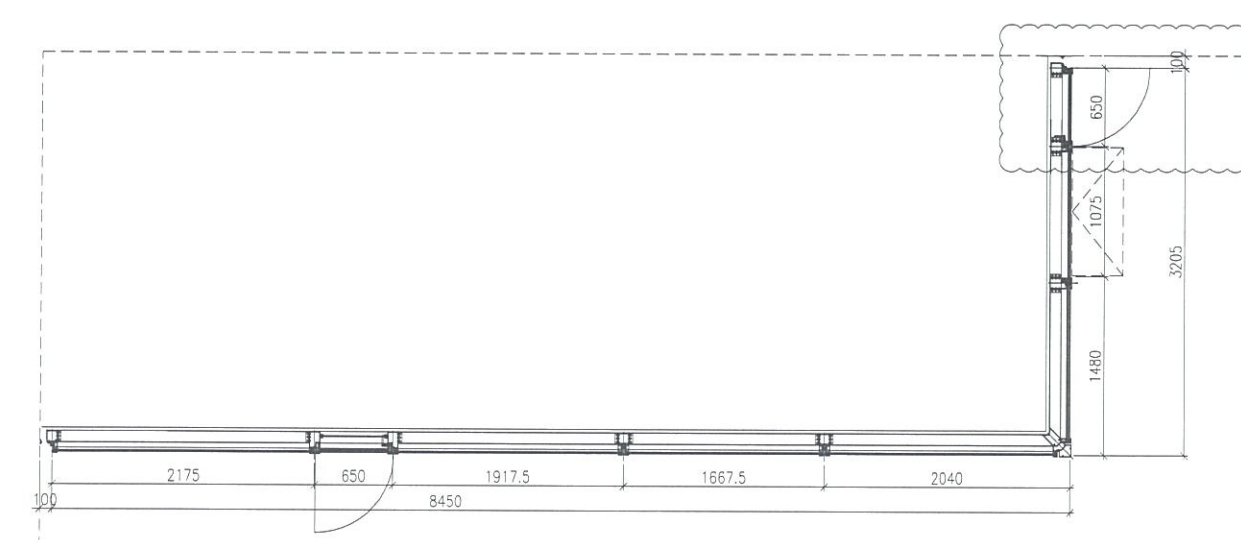

4 PLAN FOR CURTAIN WALL

- LEGEND:**
- (1) 10 mm THK. TEMPERED BLUE TINTED GLASS (OUTER) + 9 mm AIR SPACE + 8 mm THK. TEMPERED CLEAR GLASS (INNER)
 - (2) 8 mm THK. HEAT STRENGTHENED TINTED GLASS (OUTER) + 9 mm AIR SPACE + 8 mm THK. HEAT STRENGTHENED CLEAR GLASS (INNER)
 - (3) 10 mm THK. HEAT STRENGTHENED BLUE TINTED GLASS (OUTER) + 9 mm AIR SPACE + 8 mm THK. TEMPERED CLEAR GLASS (INNER)
 - (4) 8 mm THK. HEAT STRENGTHENED BLUE TINTED GLASS (SPANDREL GLASS)
 - (5) 8 mm THK. HEAT STRENGTHENED BLUE TINTED GLASS (OUTER) + 9 mm AIR SPACE + 8 mm THK. TEMPERED CLEAR GLASS (INNER)
 - (6) 8 mm THK. TEMPERED BLUE TINTED GLASS (SPANDREL GLASS)
 - S.J. - STACK JOINT
 - ALUMI - ALUM. EXTRUSION DIE NO.
 - ▲ - SUPPORT POINT
 - ◆ - RESTRAINT SOCKET

B.D. REF :

CLIENT :
 信和置業有限公司
 Sino Land Company Limited

ARCHITECT :
 WONG TUNG & PARTNERS LIMITED
 ARCHITECTS & PLANNERS

MAIN CONTRACTOR :
 CR Construction Company Limited

STRUCTURAL ENGINEER :
 AECOM

FACADE CONSULTANT:
 AECOM

NOTE :
 1. ALL DIMENSIONS ARE IN mm.
 2. ALL ELEVATIONS ARE VIEWED FROM OUTSIDE.
 3. ALL DIMENSIONS TO BE VERIFIED ON SITE BEFORE FABRICATION.

LEGEND :
 (X1) - DETAIL MARK NO.
 (X001) - REFER SHEET NO.
 1. F.F.L. -- FINISHED FLOOR LEVEL
 2. S.F.L. -- STRUCTURAL FLOOR LEVEL
 3. (R) -- REVERSED DETAIL

NO.	DATE	REVISED	BY
F	12/5/2019	GENERAL REVISED	
E	17/4/2019	GENERAL REVISED	
D	2/3/2019	GENERAL REVISED	
C	20/12/2018	GENERAL REVISED	
B	30/11/2018	GENERAL REVISED	
A	26/9/2018	GENERAL REVISED	

JOB NO. : J-837
 PROJECT :
 URA KWUN TONG TOWN CENTRE
 REDEVELOPMENT (AREA 2 & 3) AT
 NKIL 6514, KWUN TONG, KWLOON

TITLE :
 ELEVATION
 FOR CURTAIN WALL
 PERFORMANCE TEST

DATE : 10-SEP-18 SCALE : 1:30 (A1)
 DRAWN BY : ASING CHECKED BY : -

英特鋁質有限公司
 MIDI ALUMINIUM FABRICATOR LTD.
 Units 6-8, Sunray Industrial Centre, 1/F
 610 Cha Kwo Ling Road, Kowloon
 Tel: 23489211-4 Fax: (852) 2727666
 DWG NO. : J837-PTCW-2101 REV. : F

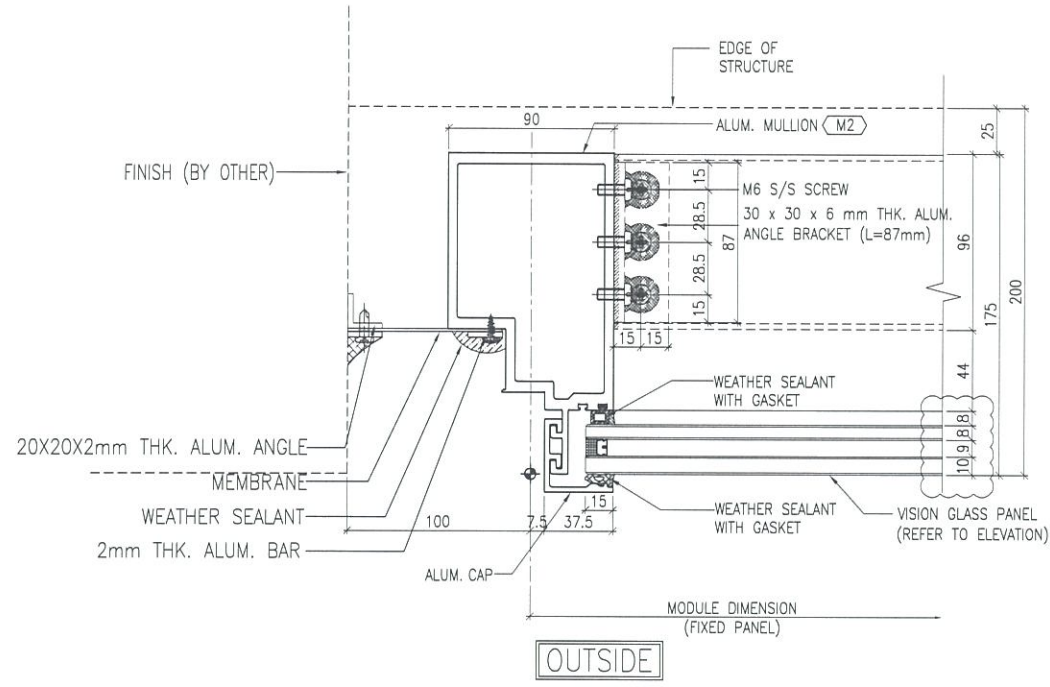

1 TYPICAL MULLION DETAIL
5001 CURTAIN WALL

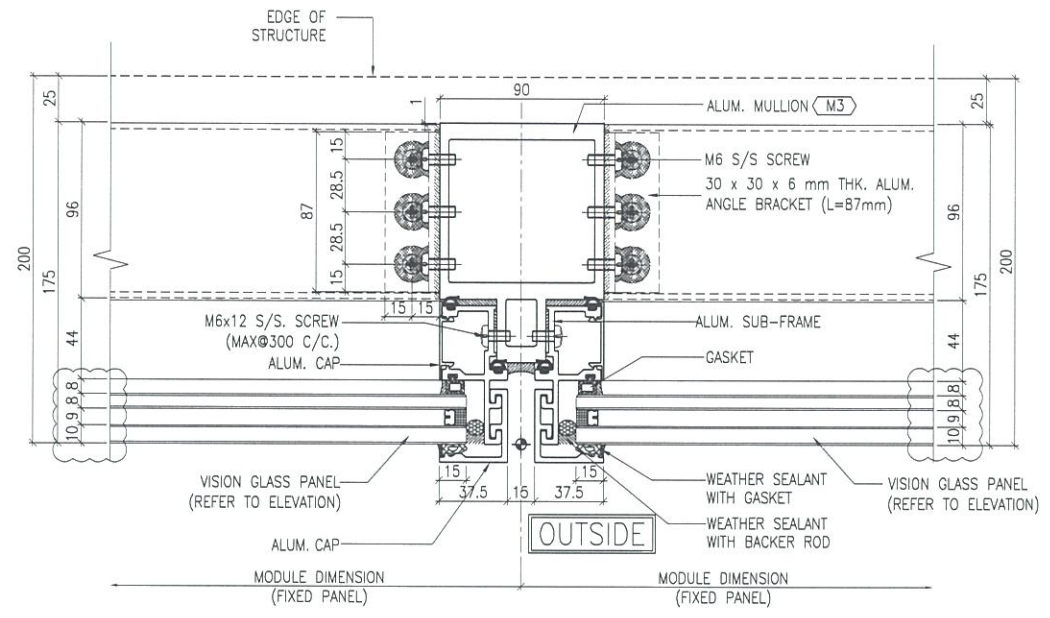

2 TYPICAL MULLION DETAIL
5001 CURTAIN WALL

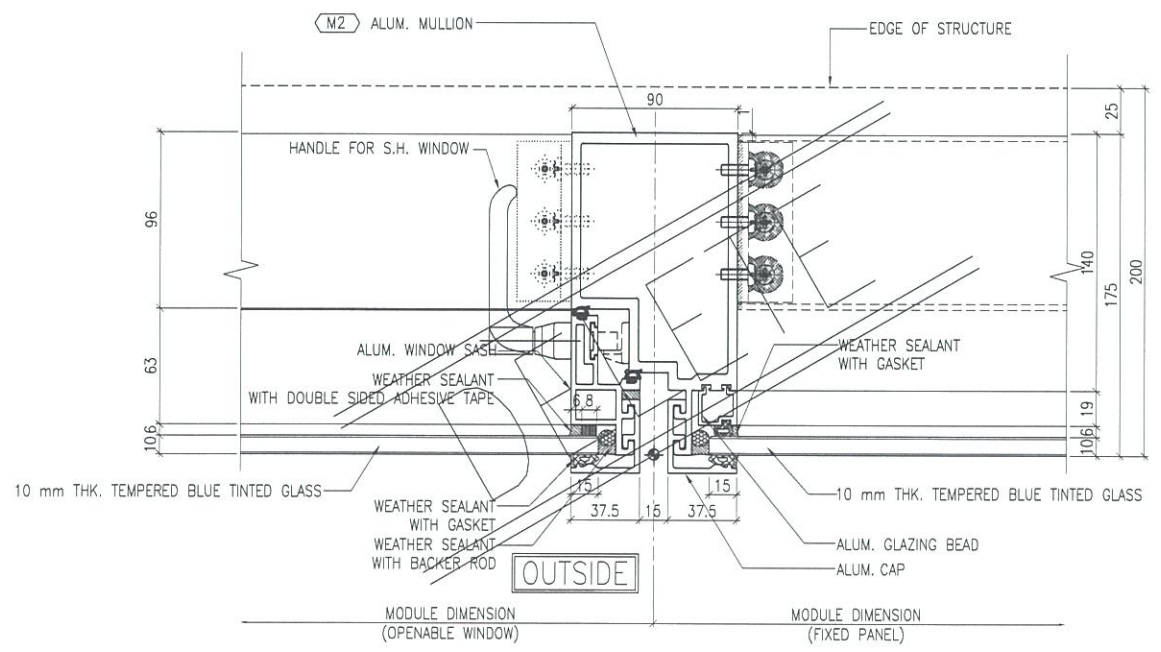

3 TYPICAL MULLION DETAIL
5001 CURTAIN WALL

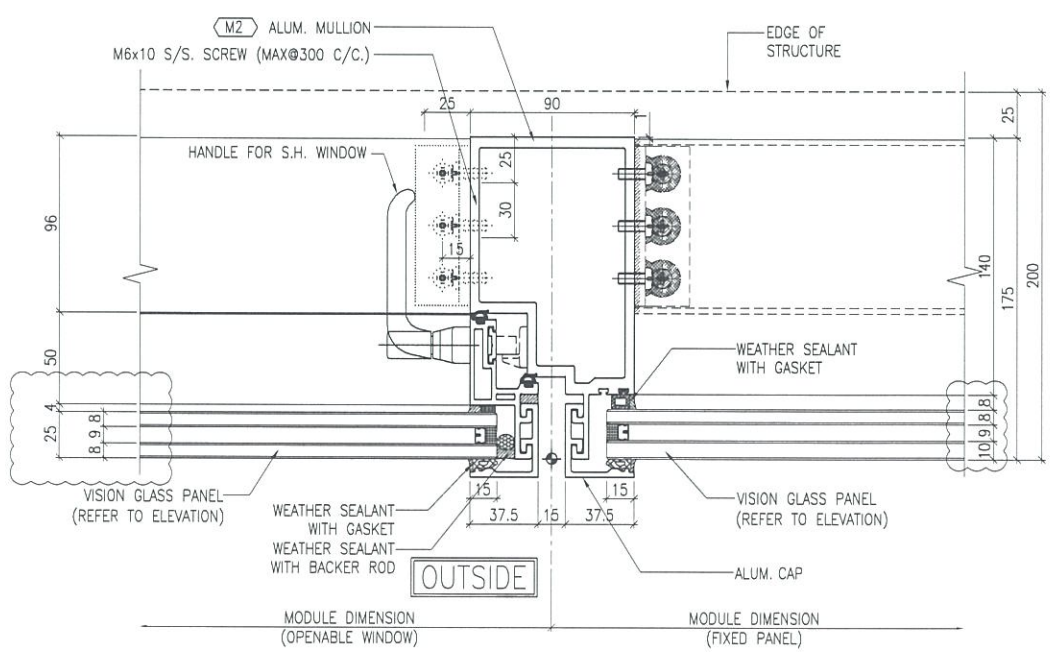

4 TYPICAL MULLION DETAIL
5001 CURTAIN WALL

B.D. REF :

CLIENT :
信和置業有限公司
Sino Land Company Limited

ARCHITECT :
WONG TUNG & PARTNERS LIMITED
ARCHITECTS & PLANNERS

MAIN CONTRACTOR :
CR Construction Company Limited

STRUCTURAL ENGINEER :
AECOM

FACADE CONSULTANT :
AECOM

NOTE :
1. ALL DIMENSIONS ARE IN mm.
2. ALL ELEVATIONS ARE VIEWED FROM OUTSIDE.
3. ALL DIMENSIONS TO BE VERIFIED ON SITE BEFORE FABRICATION.

LEGEND :
X1 --- DETAIL MARK NO.
X001 --- REFER SHEET NO.

1. F.F.L. --- FINISHED FLOOR LEVEL
2. S.F.L. --- STRUCTURAL FLOOR LEVEL
3. (R) --- REVERSED DETAIL

A	30/11/2018	GENERAL REVISED	
NO.	DATE	REVISED	BY

JOB NO. : J-837
PROJECT : URA KWUN TONG TOWN CENTRE REDEVELOPMENT (AREA 2 & 3) AT NKIL 6514, KWUN TONG, KWLOON

TITLE : TYPICAL MULLION DETAIL FOR CURTAIN WALL PERFORMANCE TEST

DATE : 10-SEP-18 SCALE : 1:2 (A1)
DRAWN BY : ASING CHECKED BY : -

美特鋁質有限公司
MIDI ALUMINIUM FABRICATOR LTD.
Units 6-8, Sunray Industrial Centre, 1/F
610 Cha Kwo Ling Road, Kowloon
Tel: 23489211-4 Fax: (852) 2727666

DWG NO. : JB37-PTCW-5001 REV. : A

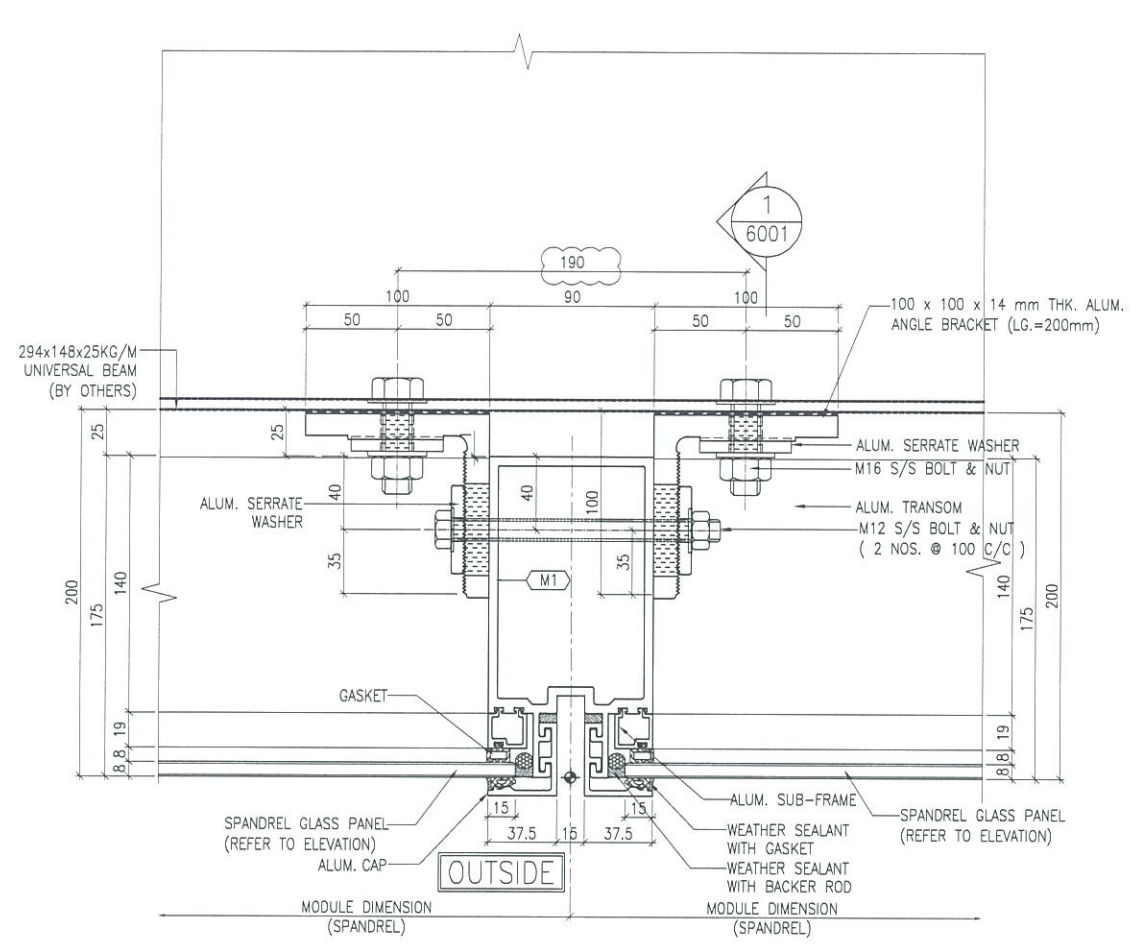

1 TYPICAL MULLION DETAIL
5004 CURTAIN WALL

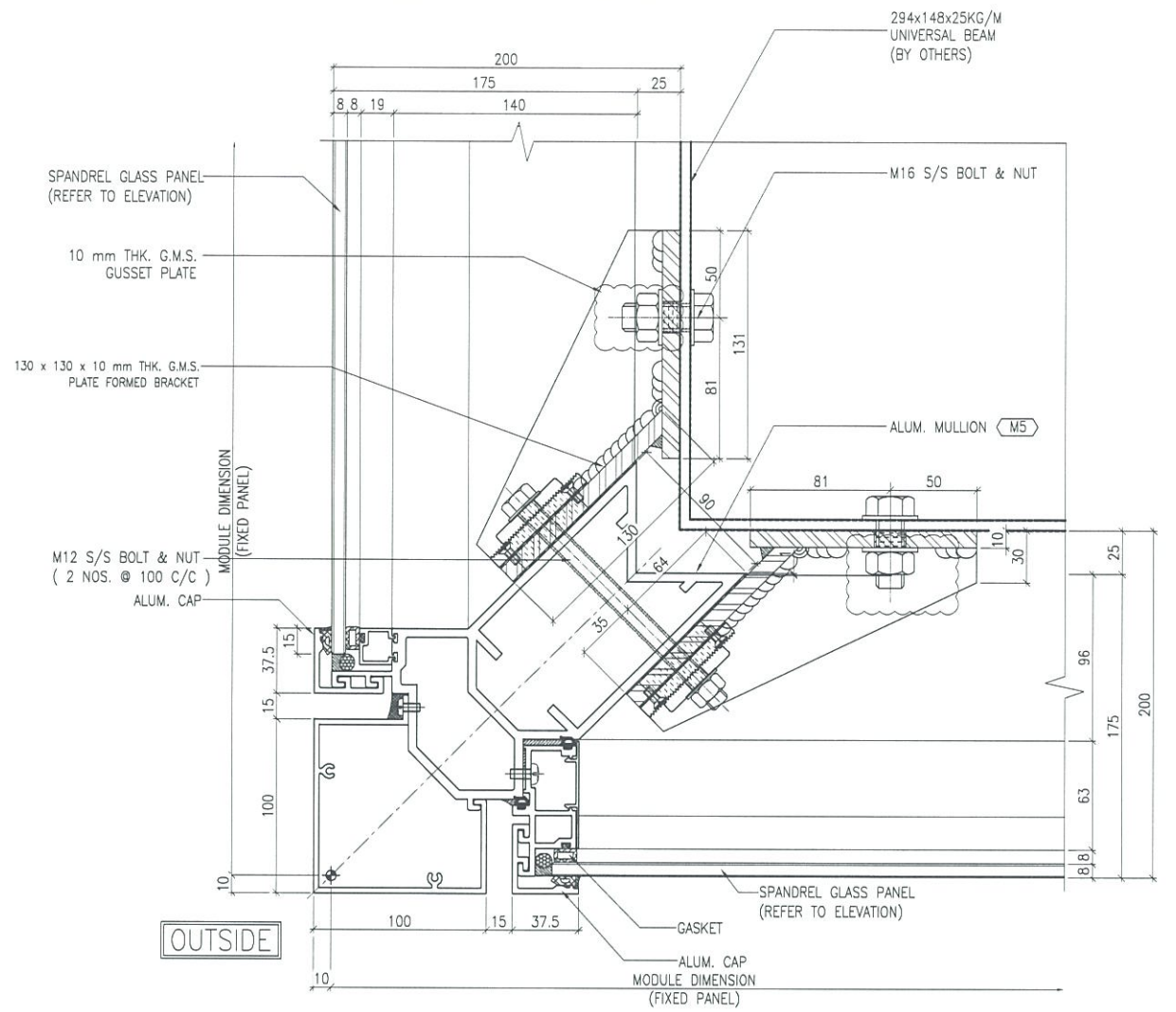

2 TYPICAL MULLION DETAIL
5004 CURTAIN WALL

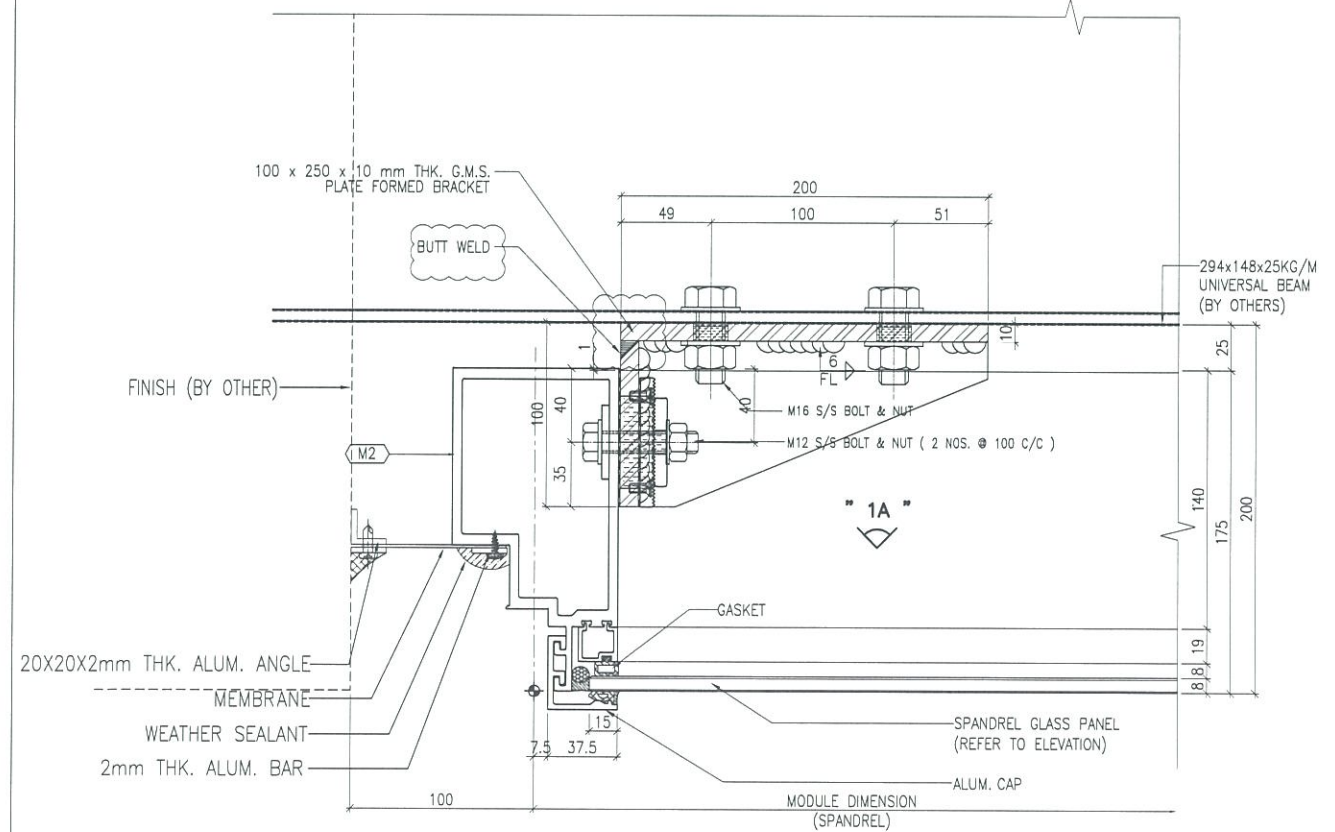

3 TYPICAL MULLION DETAIL
5004 CURTAIN WALL

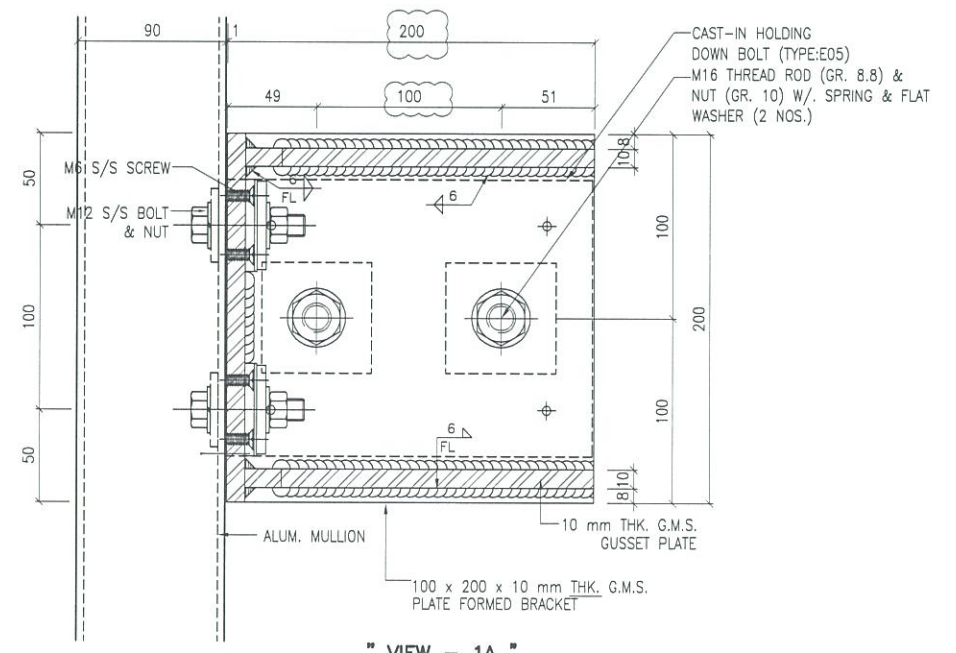

" VIEW - 1A "

B.D. REF :

CLIENT :
信和置業有限公司
Sino Land Company Limited

ARCHITECT :
WONG TUNG & PARTNERS LIMITED
ARCHITECTS & PLANNERS

MAIN CONTRACTOR :
CR Construction Company Limited

STRUCTURAL ENGINEER :
AECOM

FAÇADE CONSULTANT :
AECOM

NOTE :
1. ALL DIMENSIONS ARE IN mm.
2. ALL ELEVATIONS ARE VIEWED FROM OUTSIDE.
3. ALL DIMENSIONS TO BE VERIFIED ON SITE BEFORE FABRICATION.

LEGEND :
X1 --- DETAIL MARK NO.
X001 --- REFER SHEET NO.

1. F.F.L. --- FINISHED FLOOR LEVEL
2. S.F.L. --- STRUCTURAL FLOOR LEVEL
3. (R) --- REVERSED DETAIL

C	2/3/2019	GENERAL REVISED	
B	30/11/2018	GENERAL REVISED	
A	26/9/2018	GENERAL REVISED	
NO.	DATE	REVISED	BY

JOB NO. : J-837
PROJECT :
URA KWUN TONG TOWN CENTRE
REDEVELOPMENT (AREA 2 & 3) AT
NKIL 6514, KWUN TONG, KWLOON

TITLE :
TYPICAL MULLION DETAIL
FOR CURTAIN WALL
PERFORMANCE TEST

DATE : 10-SEP-18 SCALE : 1:2 (A1)
DRAWN BY : ASING CHECKED BY : -

美特鋁質有限公司
MIDI ALUMINIUM FABRICATOR LTD.
Units 6-8, Sunray Industrial Centre, 1/F
610 Cha Kwo Ling Road, Kowloon
Tel: 23489211-4 Fax: (852) 2727666

DWG NO. : J837-PTCW-5004 REV. : C

B.D. REF :

CLIENT :
 信和置業有限公司
 Sino Land Company Limited

ARCHITECT :
 WONG TUNG & PARTNERS LIMITED
 ARCHITECTS & PLANNERS

MAIN CONTRACTOR :
 CR Construction Company Limited

STRUCTURAL ENGINEER :

FACADE CONSULTANT :

NOTE :
 1. ALL DIMENSIONS ARE IN mm.
 2. ALL ELEVATIONS ARE VIEWED FROM OUTSIDE.
 3. ALL DIMENSIONS TO BE VERIFIED ON SITE BEFORE FABRICATION.

LEGEND :

 X1 — DETAIL MARK NO.
 X001 — REFER SHEET NO.

1. F.F.L. -- FINISHED FLOOR LEVEL
 2. S.F.L. -- STRUCTURAL FLOOR LEVEL
 3. (R) -- REVERSED DETAIL

NO.	DATE	REVISED	BY

JOB NO. : J-837
 PROJECT :
 URA KWUN TONG TOWN CENTRE
 REDEVELOPMENT (AREA 2 & 3) AT
 NKIL 6514, KWUN TONG, KWLOON

TITLE :
 TYPICAL MULLION DETAIL
 FOR CURTAIN WALL
 PERFORMANCE TEST

DATE : 10-SEP-18 SCALE : 1:2 (A1)

DRAWN BY : ASING CHECKED BY : -

 美特鋁質有限公司
 MIDI ALUMINIUM FABRICATOR LTD.
 Units 6-8, Sunray Industrial Centre, 1/F
 610 Cha Kwo Ling Road, Kowloon
 Tel: 23489211-4 Fax: (852) 27727666

DWG NO. : JB37-PTCW-5005 REV. : -

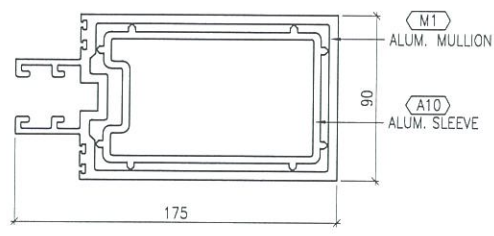

" VIEW - '1B "

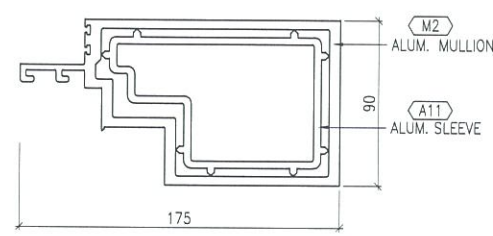

" VIEW - '2B "

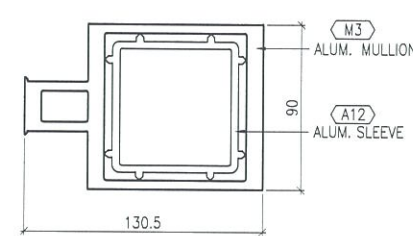

" VIEW - '3B "

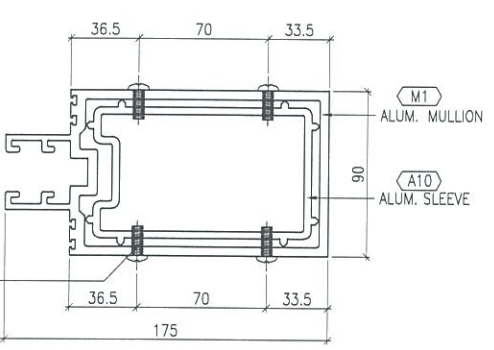
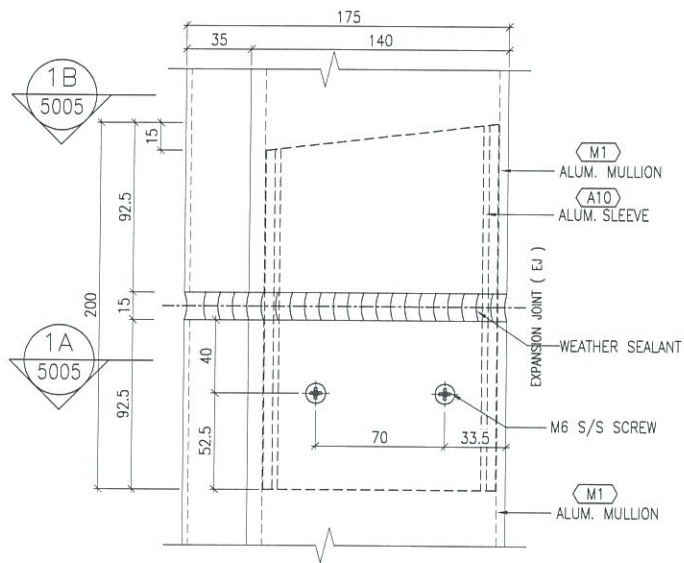

" VIEW - 1A "

" ALUMINIUM CURTAIN WALL SLEEVE "
 - TYPICAL FIXING DETAIL

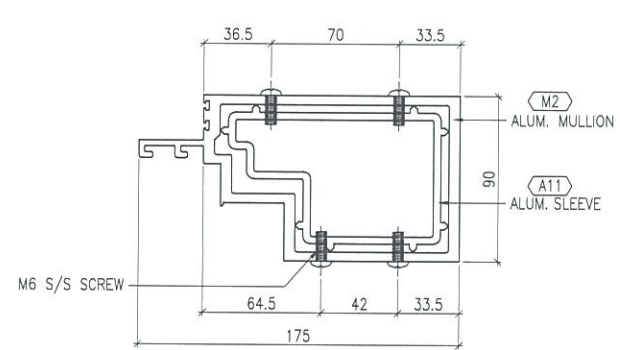
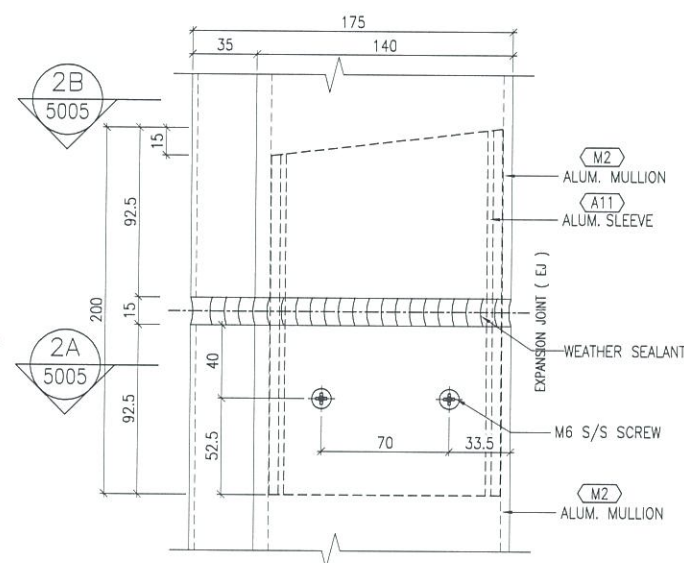

" VIEW - 2A "

" ALUMINIUM CURTAIN WALL SLEEVE "
 - TYPICAL FIXING DETAIL

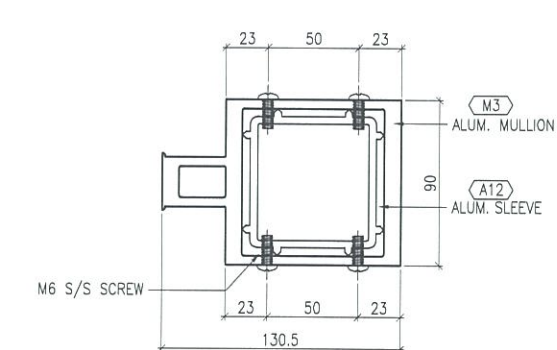
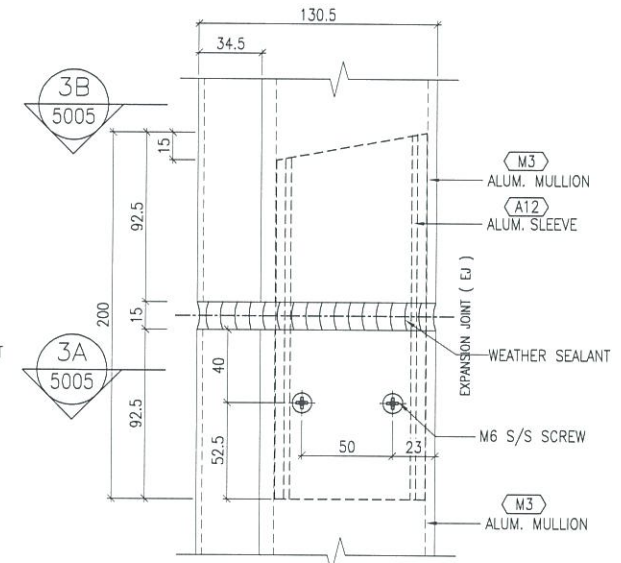

" VIEW - 3A "

" ALUMINIUM CURTAIN WALL SLEEVE "
 - TYPICAL FIXING DETAIL

1
 5005 TYPICAL MULLION DETAIL
 CURTAIN WALL

2
 5005 TYPICAL MULLION DETAIL
 CURTAIN WALL

3
 5005 TYPICAL MULLION DETAIL
 CURTAIN WALL

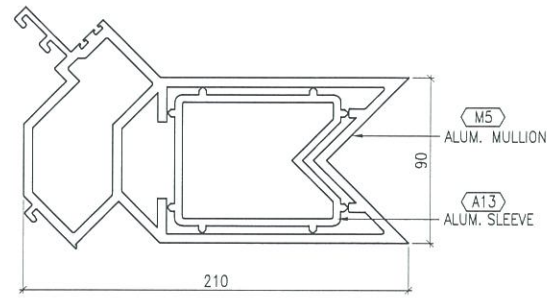

" VIEW - '1B "

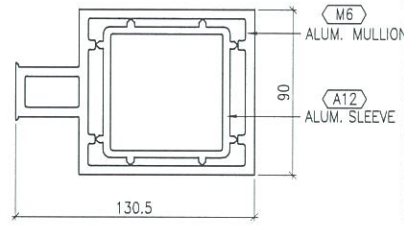

" VIEW - '2B "

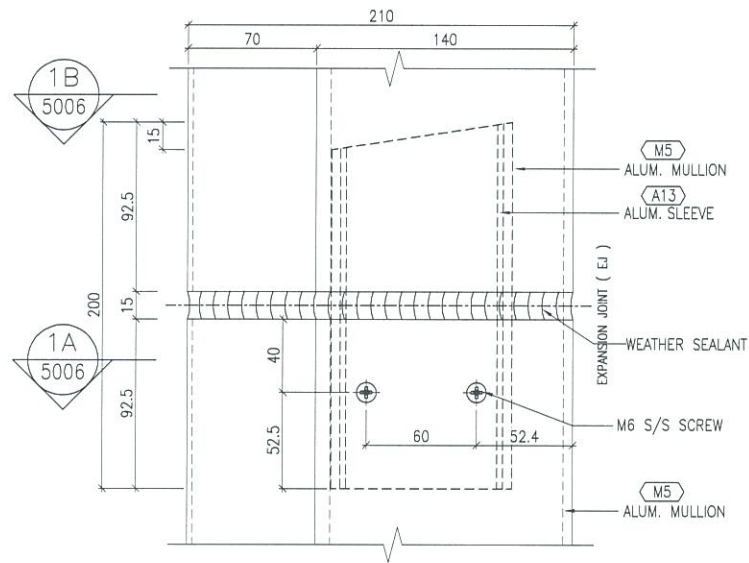

" VIEW - 1A "

" ALUMINIUM CURTAIN WALL SLEEVE " - TYPICAL FIXING DETAIL

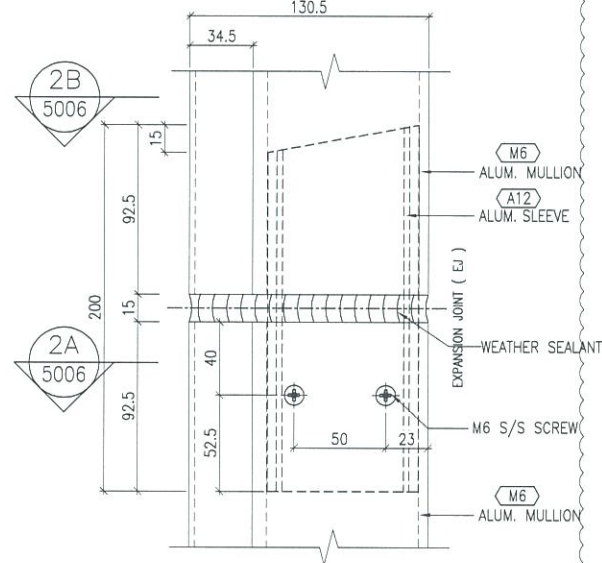

" VIEW - 2A "

" ALUMINIUM CURTAIN WALL SLEEVE " - TYPICAL FIXING DETAIL

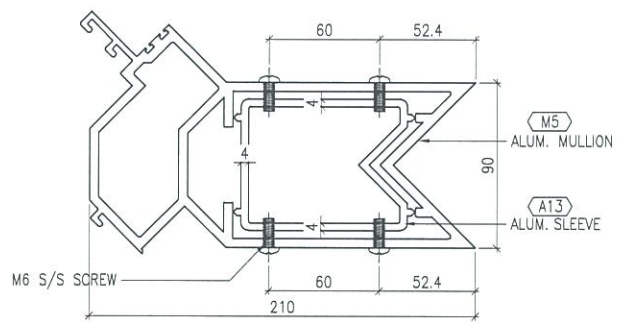

" VIEW - 1A "

" ALUMINIUM CURTAIN WALL SLEEVE " - TYPICAL FIXING DETAIL

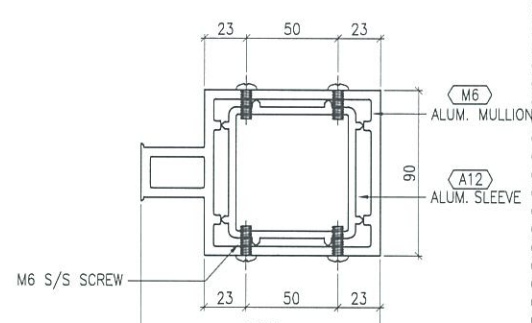

" VIEW - 2A "

" ALUMINIUM CURTAIN WALL SLEEVE " - TYPICAL FIXING DETAIL

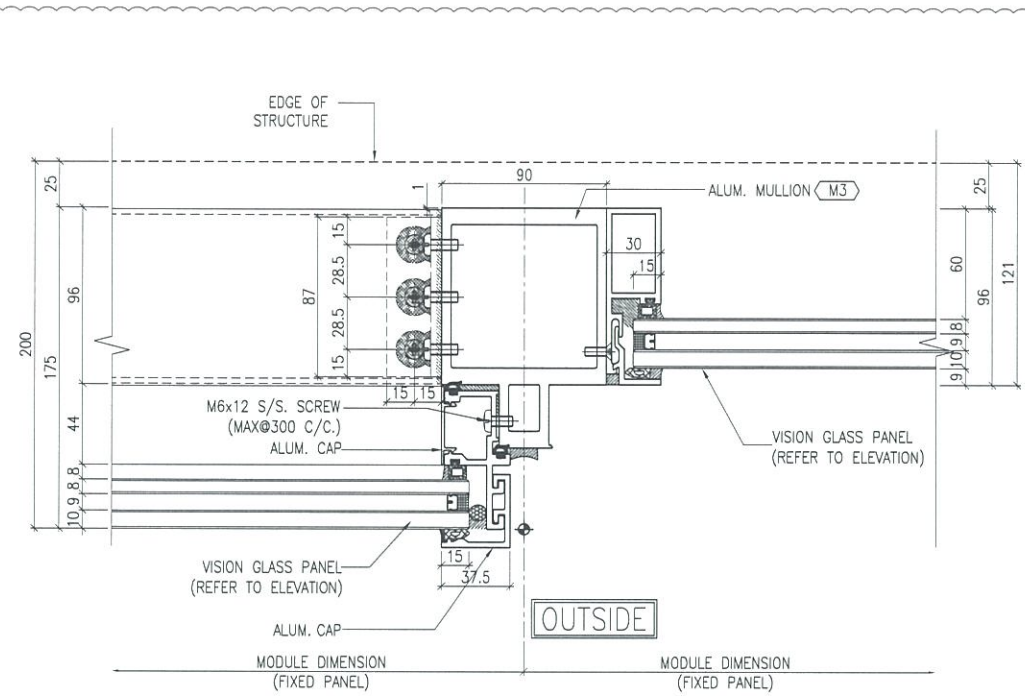

3 TYPICAL MULLION DETAIL CURTAIN WALL 5006

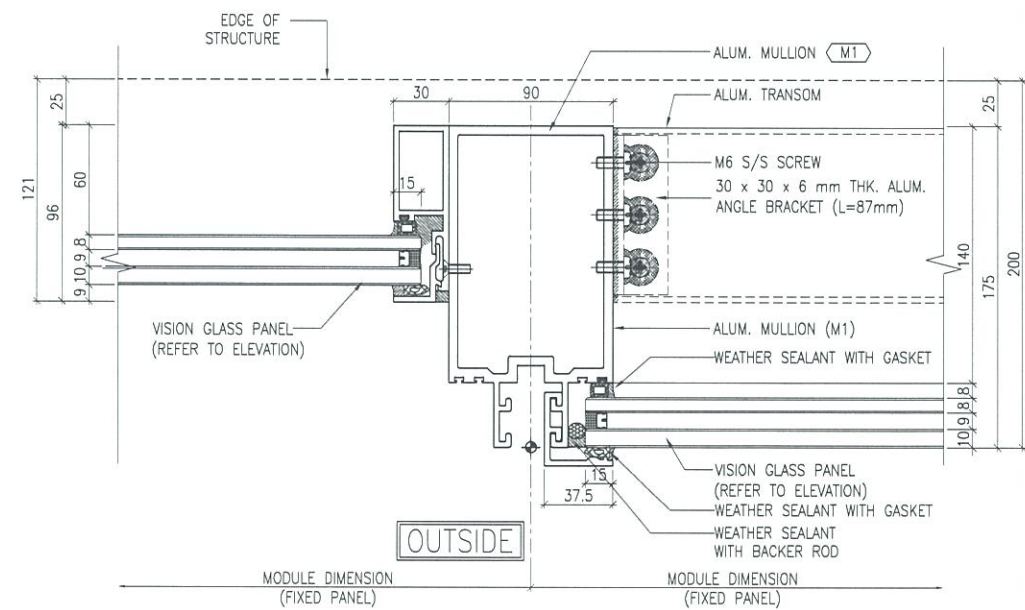

4 TYPICAL MULLION DETAIL CURTAIN WALL 5006

B.D. REF :

CLIENT :

信和置業有限公司
Sino Land Company Limited

ARCHITECT :
WONG TUNG & PARTNERS LIMITED
ARCHITECTS & PLANNERS



MAIN CONTRACTOR :

CR Construction Company Limited

STRUCTURAL ENGINEER :

AECOM

FACADE CONSULTANT:

AECOM

NOTE :

1. ALL DIMENSIONS ARE IN mm.
2. ALL ELEVATIONS ARE VIEWED FROM OUTSIDE.
3. ALL DIMENSIONS TO BE VERIFIED ON SITE BEFORE FABRICATION.

LEGEND :

- X1 --- DETAIL MARK NO.
- X001 --- REFER SHEET NO.

1. F.F.L. --- FINISHED FLOOR LEVEL
2. S.F.L. --- STRUCTURAL FLOOR LEVEL
3. (R) --- REVERSED DETAIL

A	DATE	GENERAL REVISED	BY
17/4/2019			

JOB NO. : J-837

PROJECT :
URA KWUN TONG TOWN CENTRE
REDEVELOPMENT (AREA 2 & 3) AT
NKIL 6514, KWUN TONG, KWLOON

TITLE :
TYPICAL MULLION DETAIL
FOR CURTAIN WALL
PERFORMANCE TEST

DATE : 10-SEP-18 SCALE : 1:2 (A1)

DRAWN BY : ASING CHECKED BY : -

美特鋁質有限公司
MIDI ALUMINIUM FABRICATOR LTD.
Units 6-8, Sunray Industrial Centre, 1/F
610 Cha Kwo Ling Road, Kowloon
Tel: 23489211-4 Fax: (852) 2727666

DWG NO. : JB37-PTCW-5006 REV. : A

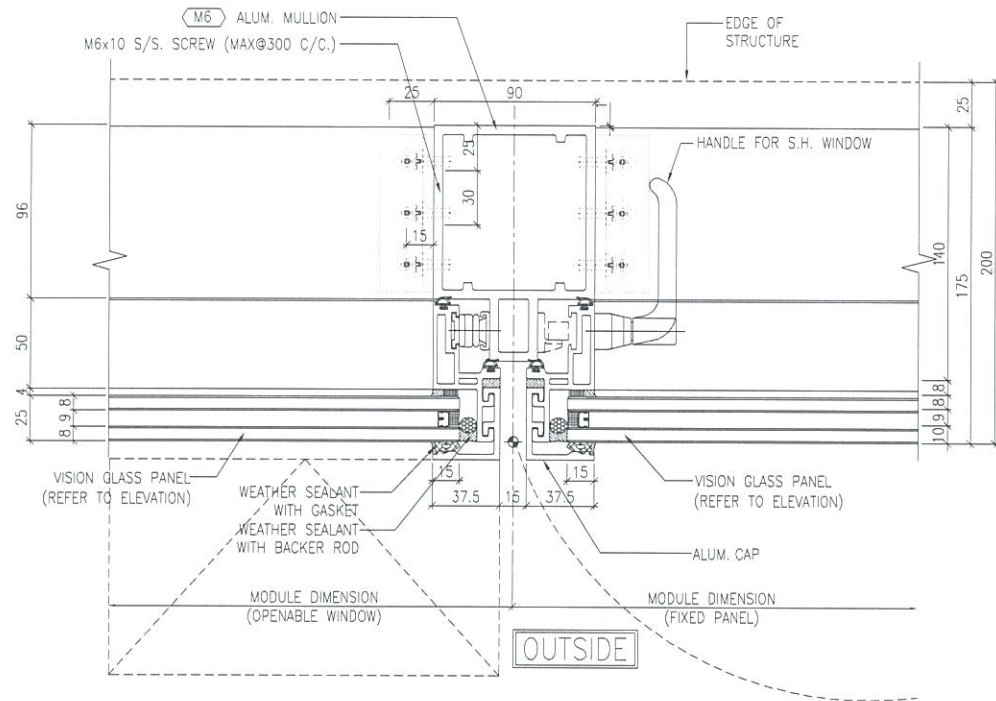

1
5007 TYPICAL MULLION DETAIL
CURTAIN WALL

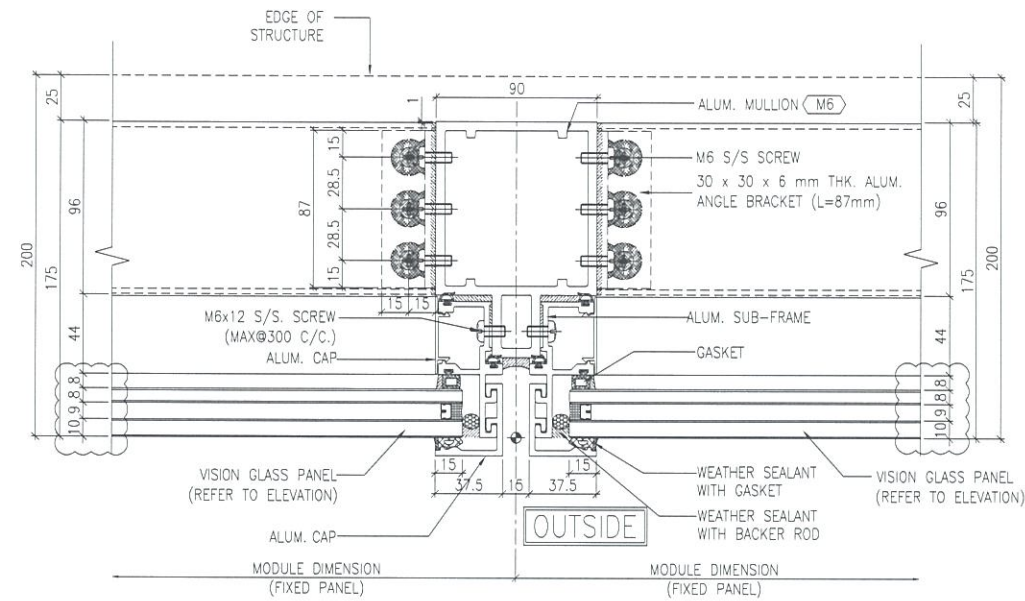

2
5007 TYPICAL MULLION DETAIL
CURTAIN WALL

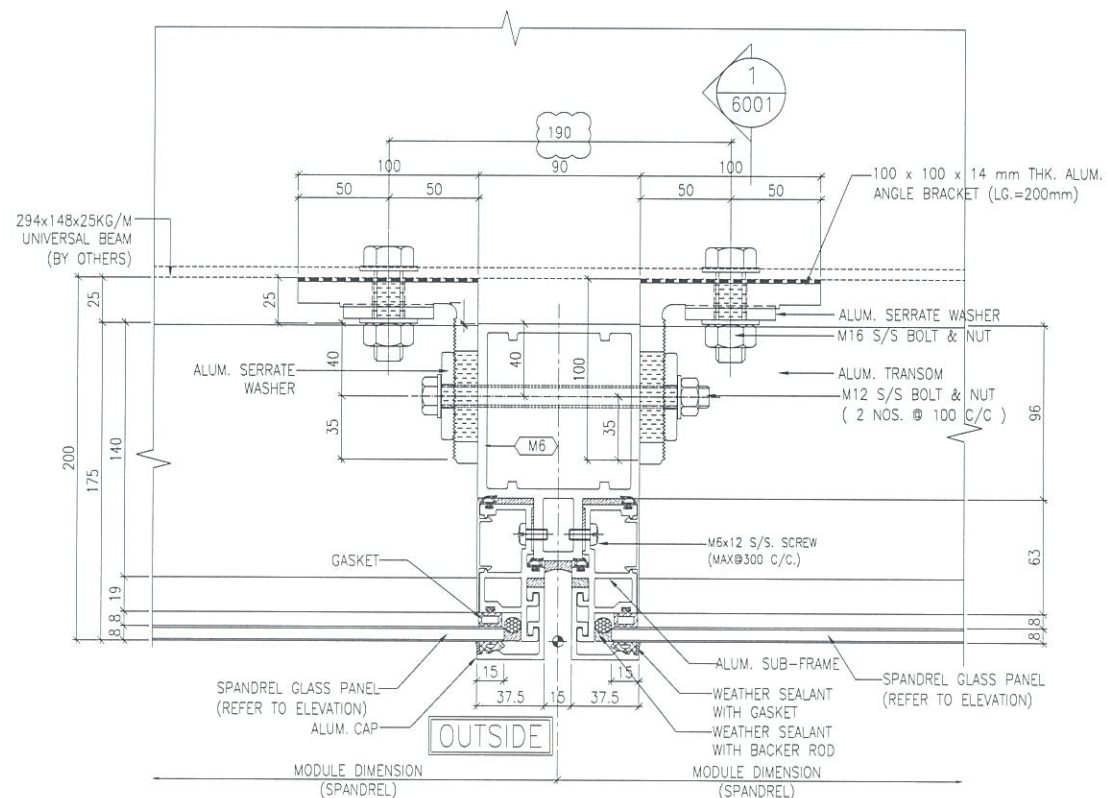

3
5007 TYPICAL MULLION DETAIL
CURTAIN WALL

B.D. REF :

CLIENT :
 信和置業有限公司
 Sino Land Company Limited

ARCHITECT :
 WONG TUNG & PARTNERS LIMITED
 ARCHITECTS & PLANNERS

MAIN CONTRACTOR :
 CR Construction Company Limited

STRUCTURAL ENGINEER :
 AECOM

FACADE CONSULTANT:
 AECOM

NOTE :
 1. ALL DIMENSIONS ARE IN mm.
 2. ALL ELEVATIONS ARE VIEWED FROM OUTSIDE.
 3. ALL DIMENSIONS TO BE VERIFIED ON SITE BEFORE FABRICATION.

LEGEND :
 X1 -- DETAIL MARK NO.
 X001 -- REFER SHEET NO.
 1. F.F.L. -- FINISHED FLOOR LEVEL
 2. S.F.L. -- STRUCTURAL FLOOR LEVEL
 3. (R) -- REVERSED DETAIL

NO.	DATE	REVISED	BY

JOB NO. : J-837
 PROJECT :
 URA KWUN TONG TOWN CENTRE
 REDEVELOPMENT (AREA 2 & 3) AT
 NKIL 6514, KWUN TONG, KWLOON

TITLE :
 TYPICAL MULLION DETAIL
 FOR CURTAIN WALL
 PERFORMANCE TEST

DATE : 12-MAY-18 SCALE : 1:2 (A1)
 DRAWN BY : ASING CHECKED BY : -

美特鋁質有限公司
 MIDI ALUMINIUM FABRICATOR LTD.
 Units 6-8, Sunray Industrial Centre, 1/F
 610 Cha Kwo Ling Road, Kowloon
 Tel: 23489211-4 Fax: (852) 2727666

DWG NO. : J837-PTCW-5007 REV. : -

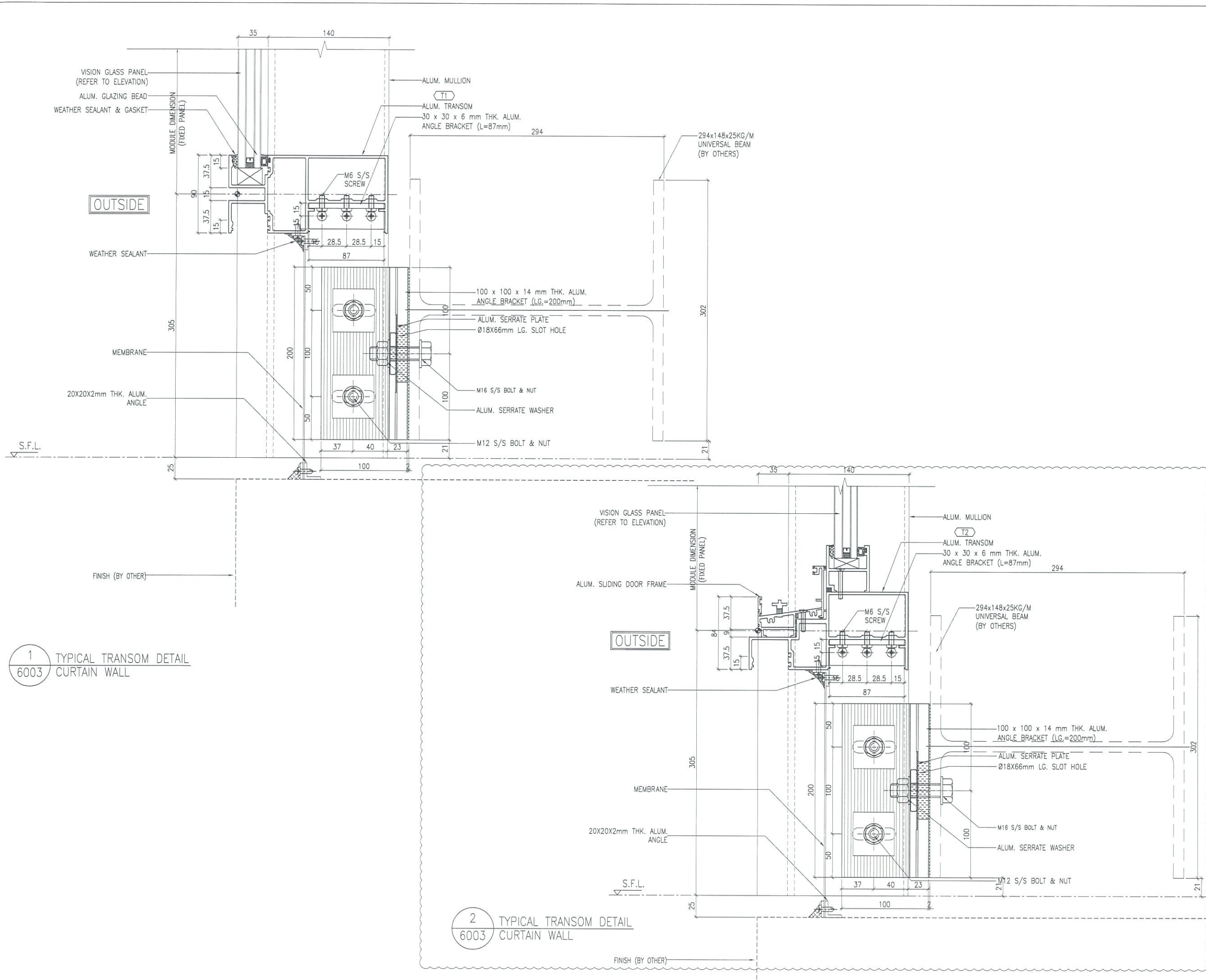

B.D. REF :

CLIENT :
 信和置業有限公司
 Sino Land Company Limited

ARCHITECT :
 WONG TUNG & PARTNERS LIMITED
 ARCHITECTS & PLANNERS

MAIN CONTRACTOR :
 CR Construction Company Limited

STRUCTURAL ENGINEER :
 AECOM

FACADE CONSULTANT:
 AECOM

NOTE :
 1. ALL DIMENSIONS ARE IN mm.
 2. ALL ELEVATIONS ARE VIEWED FROM OUTSIDE.
 3. ALL DIMENSIONS TO BE VERIFIED ON SITE BEFORE FABRICATION.

LEGEND :
 X1 --- DETAIL MARK NO.
 X001 --- REFER SHEET NO.

1. F.F.L. --- FINISHED FLOOR LEVEL
 2. S.F.L. --- STRUCTURAL FLOOR LEVEL
 3. /R --- REVERSED DETAIL

NO.	DATE	REVISED	BY
C	17/4/2019	GENERAL REVISED	
B	30/11/2018	GENERAL REVISED	
A	26/9/2018	GENERAL REVISED	

JOB NO. : J-837
 PROJECT :
 URA KWUN TONG TOWN CENTRE
 REDEVELOPMENT (AREA 2 & 3) AT
 NKIL 6514, KWUN TONG, KWLOON

TITLE :
 TYPICAL TRANSOM DETAIL
 FOR CURTAIN WALL
 PERFORMANCE TEST

DATE : 10-SEP-18 SCALE : 1:2 (A1)
 DRAWN BY : Asing CHECKED BY : -

美特鋁質有限公司
 MIDI ALUMINIUM FABRICATOR LTD.
 Units 6-8, Sunray Industrial Centre, 1/F
 610 Cha Kwo Ling Road, Kowloon
 Tel: 23489211-4 Fax: (852) 2727666

DWG NO. : JB37-PTCW-6003 REV. : C

B.D. REF :

CLIENT :
 信和置業有限公司
 Sino Land Company Limited



ARCHITECT :
 WONG TUNG & PARTNERS LIMITED
 ARCHITECTS & PLANNERS

MAIN CONTRACTOR :
 CR Construction Company Limited

STRUCTURAL ENGINEER :

FAÇADE CONSULTANT:

NOTE:
 1. ALL DIMENSIONS ARE IN mm.
 2. ALL ELEVATIONS ARE VIEWED FROM OUTSIDE.
 3. ALL DIMENSIONS TO BE VERIFIED ON SITE BEFORE FABRICATION.

LEGEND:
 X1 --- DETAIL MARK NO.
 X001 --- REFER SHEET NO.
 1. F.F.L. --- FINISHED FLOOR LEVEL
 2. S.F.L. --- STRUCTURAL FLOOR LEVEL
 3. (R) --- REVERSED DETAIL

A	30/11/2018	GENERAL REVISED	
NO.	DATE	REVISED	BY

JOB NO. : J-837
 PROJECT :
 URA KWUN TONG TOWN CENTRE
 REDEVELOPMENT (AREA 2 & 3) AT
 NKIL 6514, KWUN TONG, KWLOON

TITLE :
 TYPICAL TRANSOM DETAIL
 FOR CURTAIN WALL
 PERFORMANCE TEST

DATE : 10-SEP-18 SCALE : 1:2 (A1)
 DRAWN BY : Asing CHECKED BY : -

 美特鋁質有限公司
 MIDI ALUMINIUM FABRICATOR LTD.
 Units 6-8, Sunray Industrial Centre, 1/F
 610 Cha Kwo Ling Road, Kowloon
 Tel:23489211-4 Fax:(852)2727666

DWG NO. : JB37-PCW-6004 REV. : A

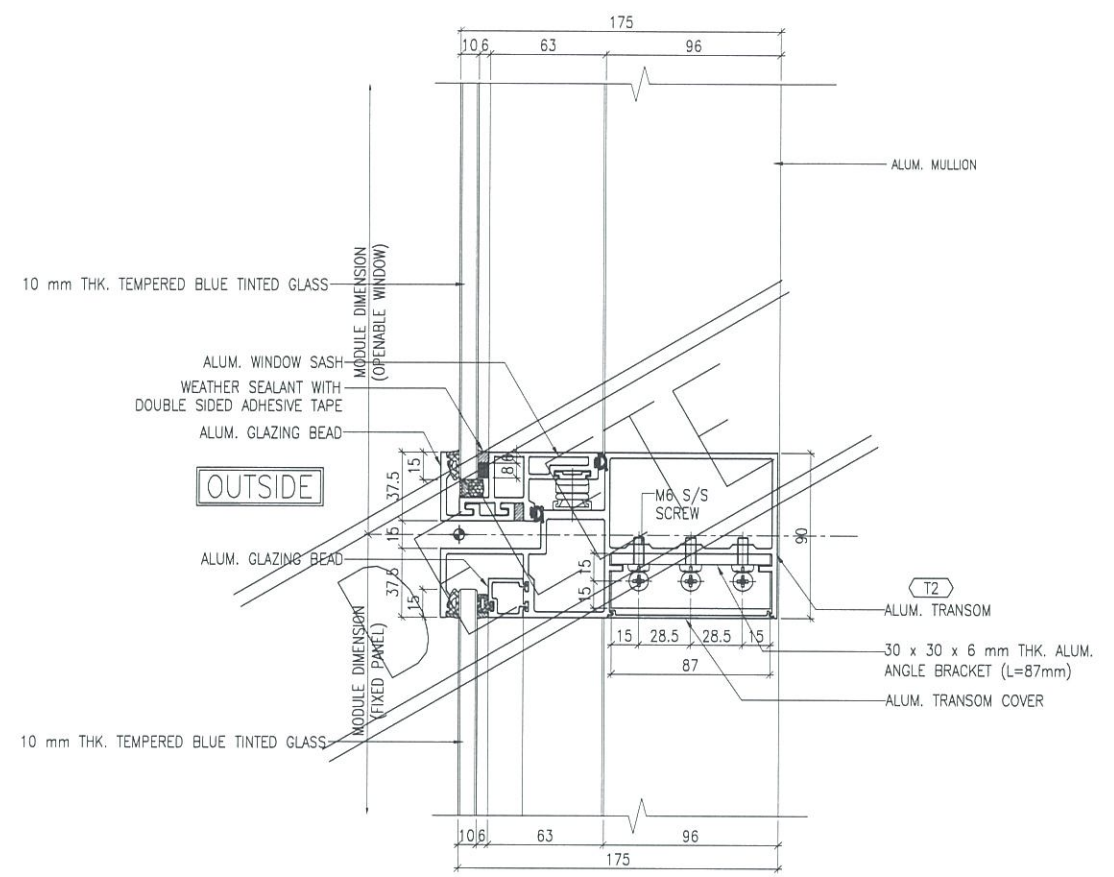

1 TYPICAL TRANSOM DETAIL
 6004 CURTAIN WALL

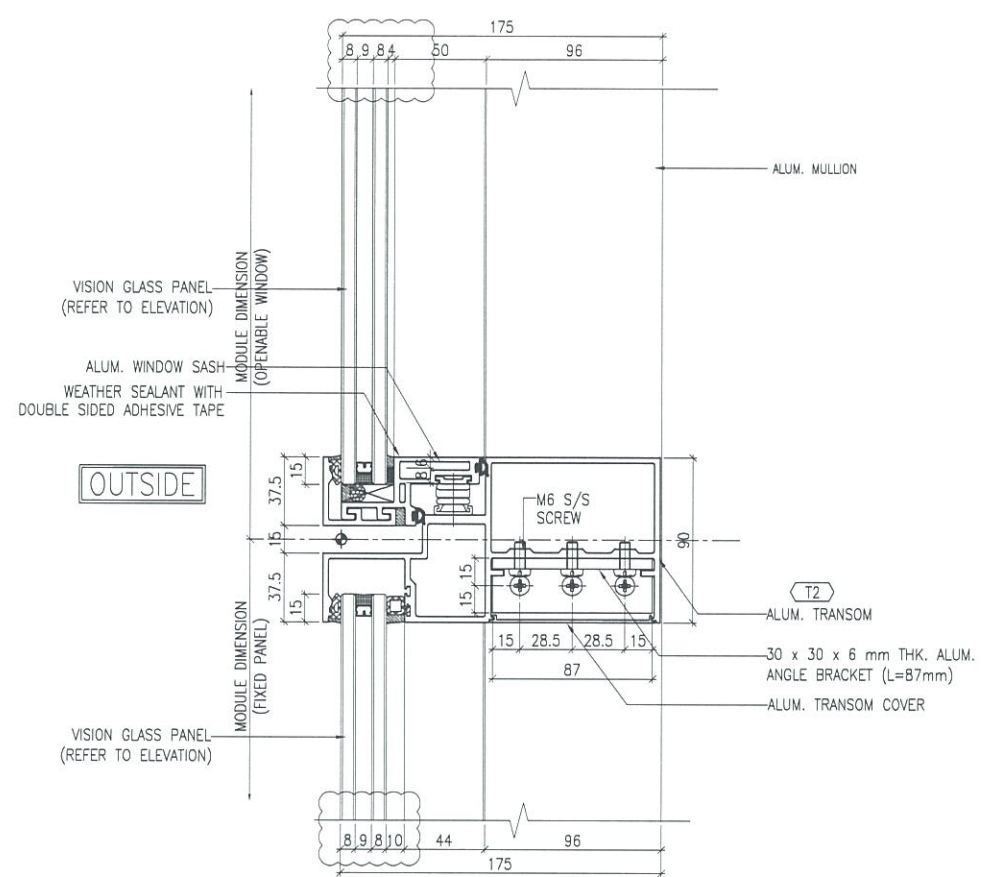

2 TYPICAL TRANSOM DETAIL
 6004 CURTAIN WALL

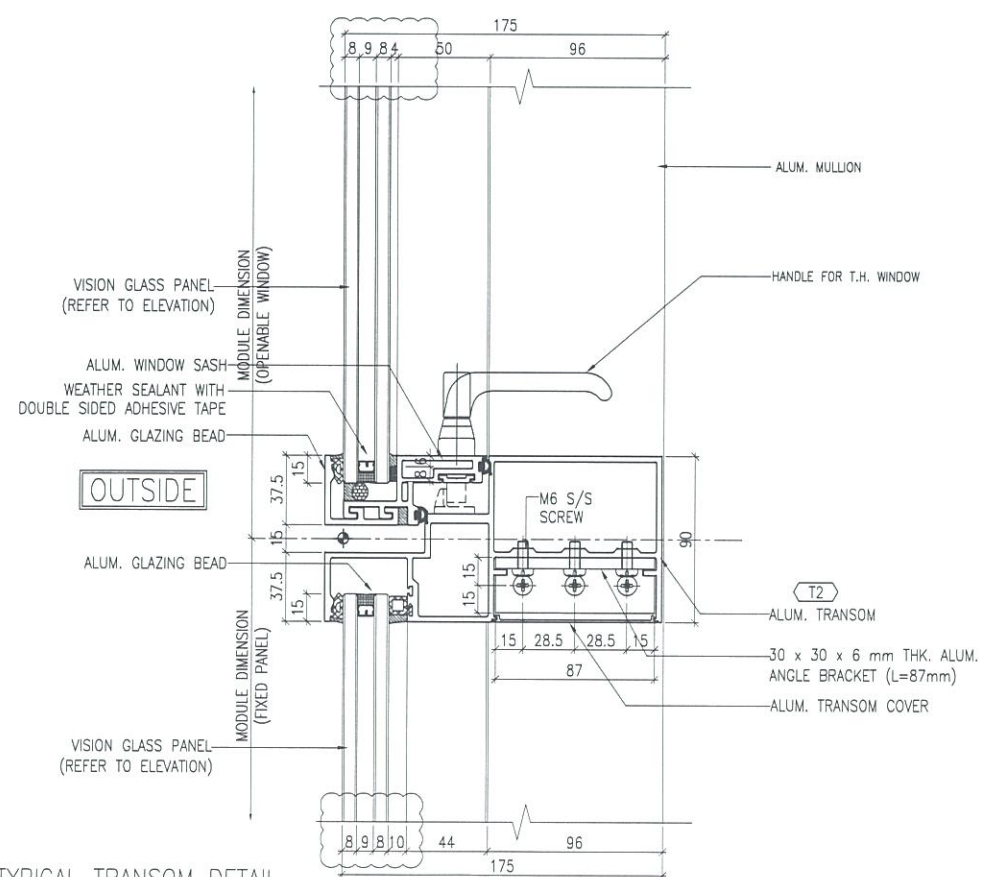

3 TYPICAL TRANSOM DETAIL
 6004 CURTAIN WALL

