



工程指示 / 要求簡箋(E.I.)

工程指示編號：EI / 9660 / 18

修改版次：-

工程編號：J - 837

工程名稱：觀塘裕民坊

工程項目：幕牆 鋁料模圖 (51 個)

收件人：Maggie

發件人：Eric Liu

日期：23/08/2018

要求提供 / 確認 事項：

- | | | |
|------------------------------------|-------------------------------------|-------------------------------|
| <input type="checkbox"/> 初步鋁料 B.M. | <input type="checkbox"/> 加工拆圖，然後生產 | <input type="checkbox"/> 尺寸表 |
| <input type="checkbox"/> 正式鋁料 B.M. | <input type="checkbox"/> 技術上資料 / 指示 | <input type="checkbox"/> 報價 |
| <input type="checkbox"/> 配件 B.M. | <input type="checkbox"/> 樣辦或貨品說明書 | <input type="checkbox"/> 分判合約 |
| <input type="checkbox"/> 其他：_____ | | |

內容：

請開新模圖共 30 個
 暫停共 21 個模，包括趟門及其餘待則師確定
 預計完成繪畫模圖：8月30日
 完成開模和試模：9月30日
 生統：請先參閱模圖
 謝謝！

請在 2018/09/05 前完成上列要求。

附：51 頁模圖+1 頁

以上項目為：

- 原合約工程包 原合約工程加 / 減賬 新工程報價

原因：-

分發東莞各部門：

- 生產技術總監 連附件 技術部 連附件 永林 生產部 連附件 機械設計部 連附件
 採購部 連附件 生產統籌部 連附件 梅
 質檢部 連附件 會計部 連附件 報關組 連附件 其他 楊榮輝 連附件

分發其他分判：

- 王禮秋 連附件

分發香港各部門：

- 行政部 連附件 會計部 連附件 統籌部 連附件 工程部地盤科文 連附件
 採購部 連附件 QS 部 連附件 維修部 連附件 其他 _____ 連附件

傳遞編號：

發件人簽署：Z

HK 1311 / 18

項目經理簽署：Pip

EI 23/08/2018

| Page | PART | Grade | Die No. | 0 | A | B | E | F | G | H |
|------|------|-------|---------|--------|----|---|---|---|---|---|
| 1 | M1 | 6063 | T6 | X85545 | 1 | | | | | |
| 2 | M2 | 6063 | T6 | X85546 | 1 | | | | | |
| 3 | M3 | 6063 | T6 | X85547 | 1 | | | | | |
| 4 | M4 | 6063 | T6 | X85548 | 1 | | | | | |
| 5 | M5 | 6063 | T6 | X85549 | 暫停 | | | | | |
| 6 | M6 | 6063 | T6 | X85550 | 1 | | | | | |
| 7 | M7 | 6063 | T6 | X85551 | 1 | | | | | |
| 8 | T1 | 6063 | T6 | X85552 | 1 | | | | | |
| 9 | T2 | 6063 | T6 | X85553 | 1 | | | | | |
| 10 | T3 | 6063 | T6 | X85554 | 1 | | | | | |
| 11 | T3A | 6063 | T6 | X85555 | 1 | | | | | |
| 12 | A01 | 6063 | T5 | X85556 | 1 | | | | | |
| 13 | A02 | 6063 | T6 | X85557 | 1 | | | | | |
| 14 | A03 | 6063 | T6 | X85558 | 1 | | | | | |
| 15 | A04 | 6063 | T6 | X85559 | 1 | | | | | |
| 16 | A05 | 6063 | T6 | X85560 | 1 | | | | | |
| 17 | A06 | 6063 | T6 | X85561 | 1 | | | | | |
| 18 | A07 | 6063 | T6 | X85562 | 1 | | | | | |
| 19 | A08 | 6063 | T5 | X85563 | 1 | | | | | |
| 20 | A09 | 6063 | T5 | X85564 | 1 | | | | | |
| 21 | A10 | 6061 | T6 | X85565 | 1 | | | | | |
| 22 | A11 | 6061 | T6 | X85566 | 1 | | | | | |
| 23 | A12 | 6061 | T6 | X85567 | 1 | | | | | |
| 24 | A13 | 6061 | T6 | X85568 | 暫停 | | | | | |
| 25 | A14 | 6061 | T6 | X85569 | 1 | | | | | |
| 26 | S01 | 6063 | T6 | X85570 | 1 | | | | | |
| 27 | S02 | 6063 | T5 | X85571 | 暫停 | | | | | |
| 28 | S03 | 6063 | T6 | X85572 | 1 | | | | | |
| 29 | S04 | 6063 | T6 | X85573 | 暫停 | | | | | |
| 30 | S05 | 6063 | T6 | X85574 | 暫停 | | | | | |
| 31 | S06 | 6063 | T6 | X85575 | 暫停 | | | | | |
| 32 | S07 | 6063 | T6 | X85576 | 暫停 | | | | | |
| 33 | S08 | 6063 | T6 | X85577 | 暫停 | | | | | |
| 34 | S09 | 6063 | T5 | X85578 | 1 | | | | | |
| 35 | S10 | 6063 | T6 | X85579 | 暫停 | | | | | |
| 36 | S12 | 6063 | T6 | X85580 | 暫停 | | | | | |
| 37 | S13 | 6063 | T6 | X85581 | 暫停 | | | | | |
| 38 | S15 | 6063 | T6 | X85582 | 暫停 | | | | | |
| 39 | S16 | 6063 | T6 | X85583 | 暫停 | | | | | |
| 40 | S17 | 6063 | T5 | X85584 | 暫停 | | | | | |
| 41 | S18 | 6063 | T6 | X85585 | 暫停 | | | | | |
| 42 | S19 | 6063 | T6 | X85586 | 暫停 | | | | | |
| 43 | F01 | 6063 | T6 | X85587 | 暫停 | | | | | |
| 44 | F02 | 6063 | T6 | X85588 | 暫停 | | | | | |
| 45 | F03 | 6063 | T5 | X85589 | 暫停 | | | | | |
| 46 | F04 | 6063 | T6 | X85590 | 暫停 | | | | | |
| 47 | F05 | 6063 | T6 | X85591 | 暫停 | | | | | |
| 48 | AB01 | 6061 | T6 | X85592 | 1 | | | | | |
| 49 | AB2 | 6061 | T6 | X85593 | 1 | | | | | |
| 50 | AB4 | 6061 | T6 | X85594 | 1 | | | | | |
| 51 | AB5 | 6063 | T5 | X85595 | 1 | | | | | |
| | | | | SUM | 30 | | | | | |

45-95

| | | | |
|----------|-------------------|---------------|--------|
| CUSTOMER | CUSTOMER APPROVAL | CUST PART NO. | M1 |
| | | SECTION NO. | X85545 |

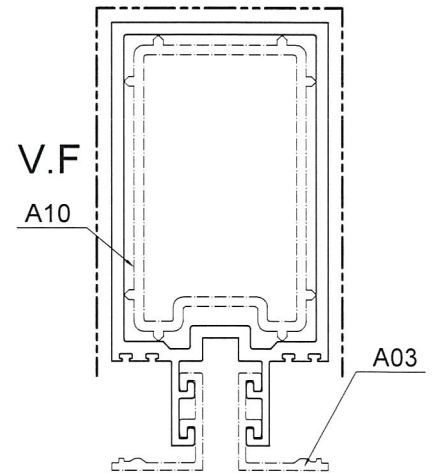
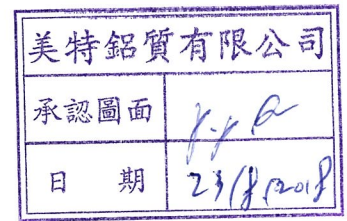
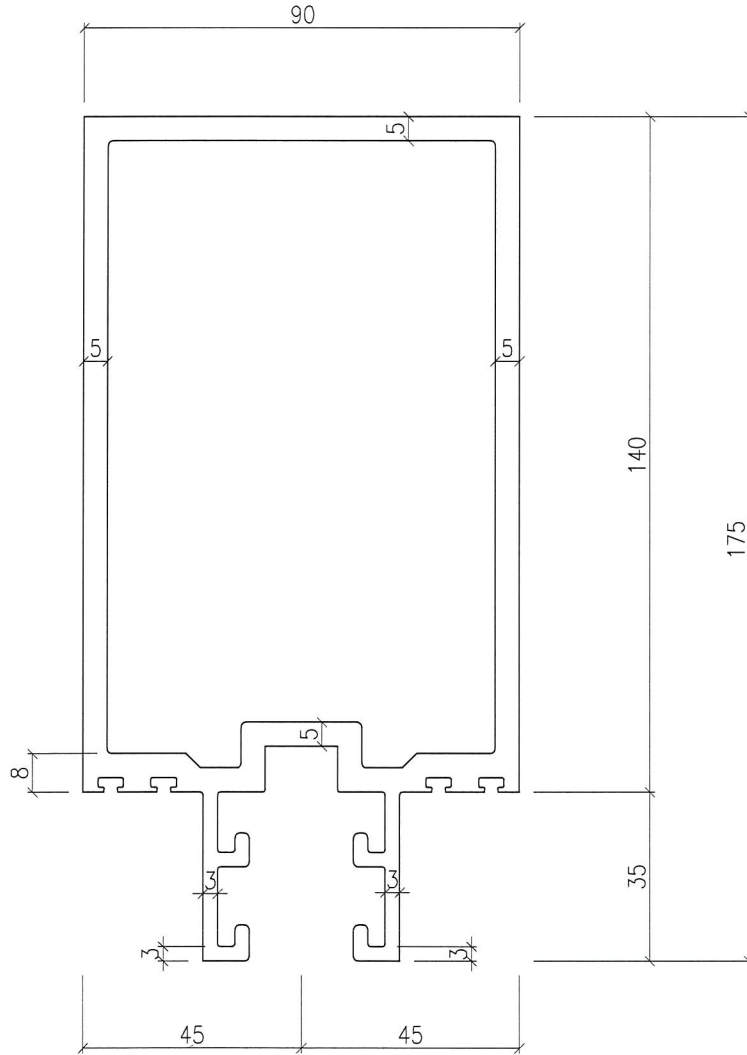

SCALE 1:2

| | | | | | | | | | |
|--------------------|-------------------------|-----------------------|-----------------|----------------|------------|----------|---------|---------|-----|
| SIGNATURE GRADEING | HIGH SIGNATURE GRADEING | C.C.DIA(MM) | | | | | | | |
| AREA (SQ MM) | 2686.6 | UNSPECIFIED THICKNESS | - | PERIMETER (MM) | - | STANDARD | | SCALE | 1:1 |
| MASS (KG/M) | - | UNSPECIFIED CORNERS | - | SURFACE AREA | - | ALLOY | 6063 T6 | VERSION | |
| COMPANY ISSUE | | | DRAWN | DATE | APELLATION | - | PAGE OF | | |
| | | | STANDARDIZATION | DATE | | | | | |
| | | | TO SIGN | DATE | | | | | |
| | | | AUDITING | DATE | | | | | |
| MARKER | MODIFY | FILE NO | SIGNATURE | DATE | APPROV | | | | |

美特鋁質有限公司
MIDI Aluminium Fabricator Ltd.

| | | | |
|----------|-------------------|---------------|--------|
| CUSTOMER | CUSTOMER APPROVAL | CUST PART NO. | M2 |
| | | SECTION NO. | Y85546 |

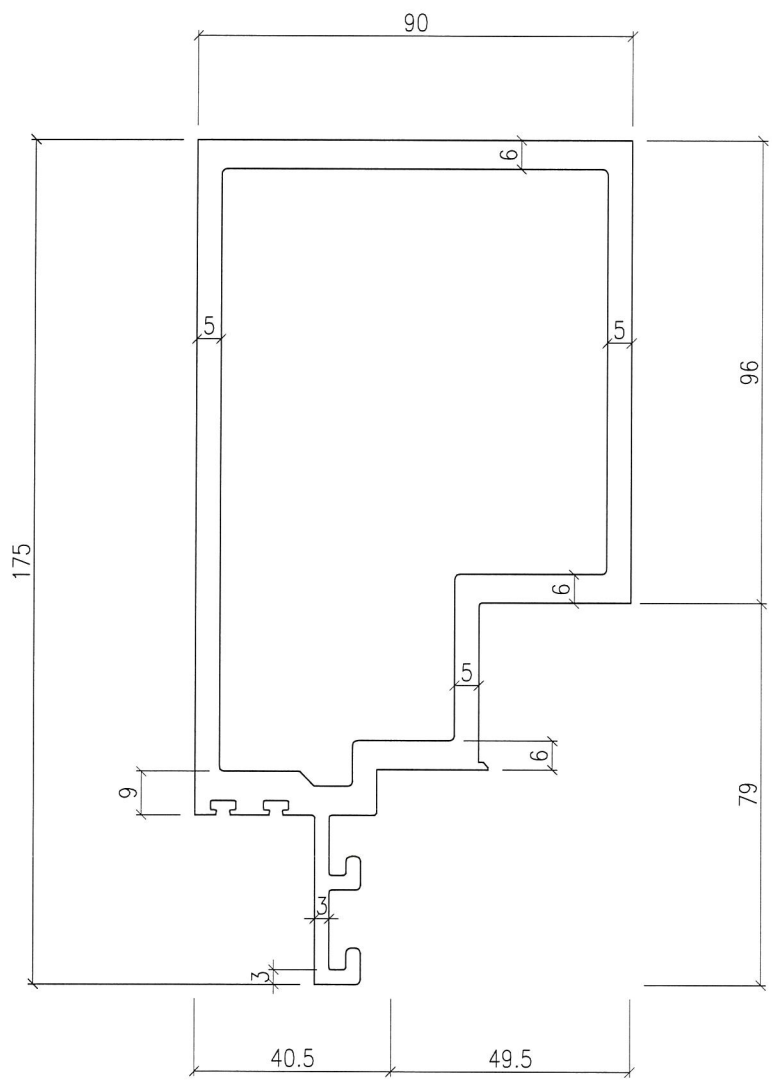

美特鋁質有限公司
承認圖面 P.P.A
日期 23.8.2018

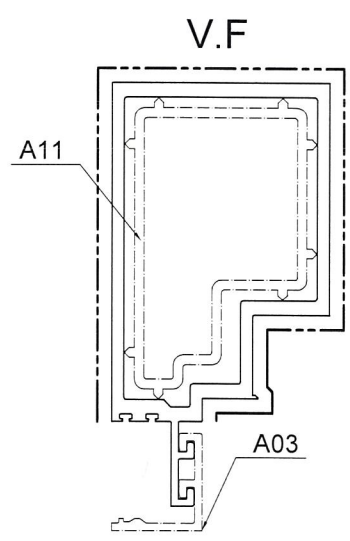

SCALE 1:2

| | | | | | | | | | |
|--------------------|-------------------------|-----------------------|-----------------|----------------|-------------|----------|---------|---------|-----|
| SIGNATURE GRADEING | HIGH SIGNATURE GRADEING | C.C.DIA(MM) | | | | | | | |
| AREA (SQ MM) | 2560.0 | UNSPECIFIED THICKNESS | - | PERIMETER (MM) | - | STANDARD | | SCALE | 1:1 |
| MASS (KG/M) | - | UNSPECIFIED CORNERS | - | SURFACE AREA | - | ALLOY | 6063 T6 | VERSION | |
| COMPANY ISSUE | | | DRAWN | DATE | APPELLATION | | - | PAGE OF | |
| | | | STANDARDIZATION | DATE | | | | | |
| | | | TO SIGN | DATE | | | | | |
| | | | AUDITING | DATE | | | | | |
| MARKER | MODIFY | FILE NO | SIGNATURE | DATE | APPROV | DATE | | | |

美特鋁質有限公司
MIDI Aluminium Fabricator Ltd.

| | | | | | |
|----------|--|-------------------|--|---------------|--------|
| CUSTOMER | | CUSTOMER APPROVAL | | CUST PART NO. | M3 |
| | | | | SECTION NO. | X85547 |

| | |
|----------|--------------------|
| 美特鋁質有限公司 | |
| 承認圖面 | <i>[Signature]</i> |
| 日期 | 23.8.2018 |

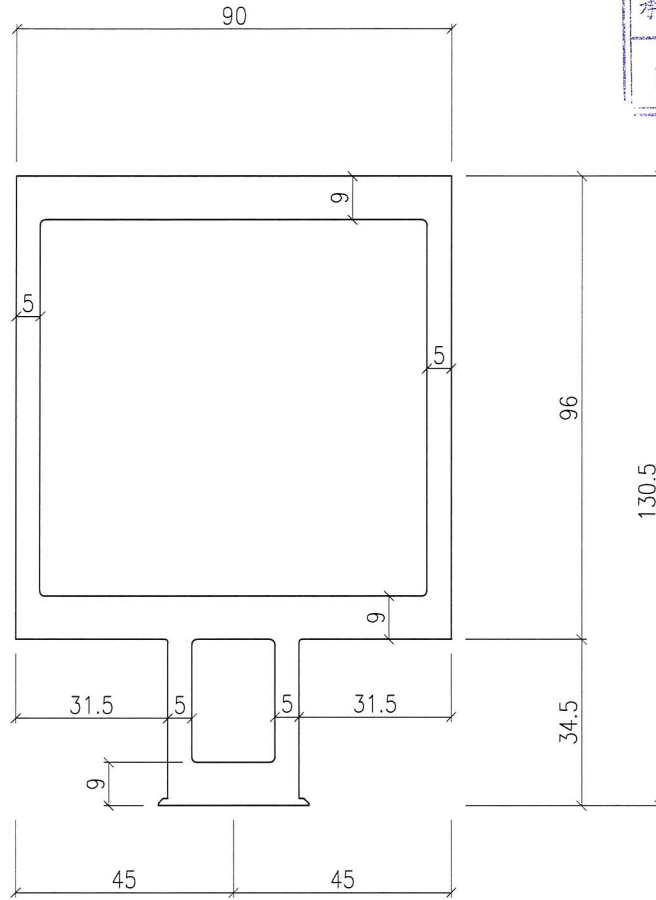

V.F

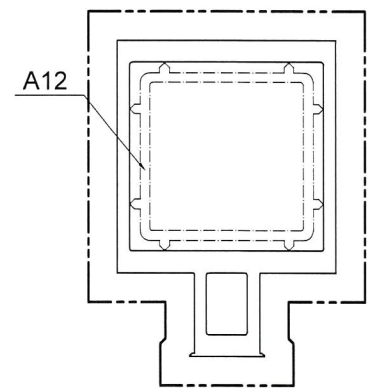

SCALE 1:2

| | | | | | | | | | |
|--------------------|-------------------------|-----------------------|-----------------|----------------|-------------|----------|---------|---------|-----|
| SIGNATURE GRADEING | HIGH SIGNATURE GRADEING | C.C.DIA(MM) | | | | | | | |
| AREA (SQ MM) | 2904.8 | UNSPECIFIED THICKNESS | - | PERIMETER (MM) | - | STANDARD | | SCALE | 1:1 |
| MASS (KG/M) | - | UNSPECIFIED CORNERS | - | SURFACE AREA | - | ALLOY | 6063 T6 | VERSION | |
| COMPANY ISSUE | | | DRAWN | DATE | APPELLATION | | - | PAGE OF | |
| | | | STANDARDIZATION | DATE | | | | | |
| | | | TO SIGN | DATE | | | | | |
| | | | AUDITING | DATE | | | | | |
| MARKER | MODIFY | FILE NO | SIGNATURE | DATE | APPROV | | | | |

 美特鋁質有限公司
MIDI Aluminium Fabricator Ltd.

| | | | | |
|----------|--|-------------------|---------------|--------|
| CUSTOMER | | CUSTOMER APPROVAL | CUST PART NO. | M6 |
| | | | SECTION NO. | X85550 |

| | |
|----------|---------------|
| 美特鋁質有限公司 | |
| 承認圖面 | <i>J.F.R.</i> |
| 日期 | 23-8-2018 |

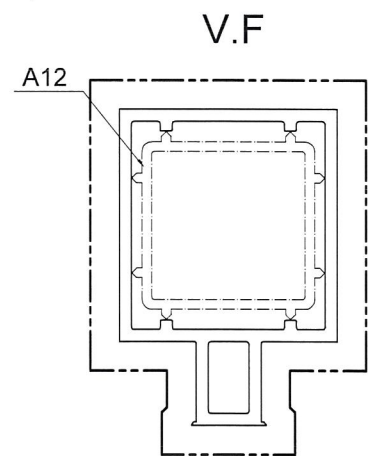
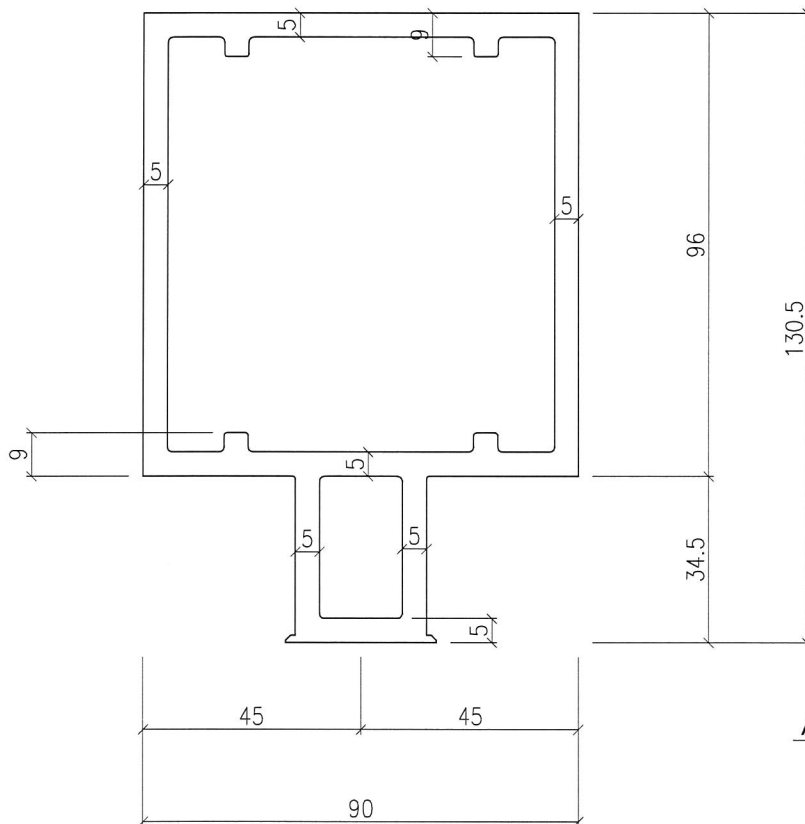

SCALE 1:2

| | | | | | | | | |
|--------------------|-------------------------|-----------------------|------------------|----------------|------------|----------|---------|-----------|
| SIGNATURE GRADEING | HIGH SIGNATURE GRADEING | C.C.DIA(MM) | | | | | | |
| AREA (SQ MM) | 2278.1 | UNSPECIFIED THICKNESS | - | PERIMETER (MM) | - | STANDARD | | SCALE 1:1 |
| MASS (KG/M) | - | UNSPECIFIED CORNERS | - | SURFACE AREA | - | ALLOY | 6063 T6 | VERSION |
| COMPANY ISSUE | | | DRAWA | DATE | APELLATION | - | PAGE OF | |
| | | | STANDA-RDIZATION | DATE | | | | |
| | | | TO SIGN | DATE | | | | |
| | | | AUDITING | DATE | | | | |
| MARKER | MODIFY | FILE NO | SIGNATURE | DATE | APPROV | | | DATE |

美特鋁質有限公司
 MIDI Aluminium Fabricator Ltd.

J.F.R.

| | | | | | |
|----------|--|-------------------|--|---------------|--------|
| CUSTOMER | | CUSTOMER APPROVAL | | CUST PART NO. | M7 |
| | | | | SECTION NO. | X85551 |

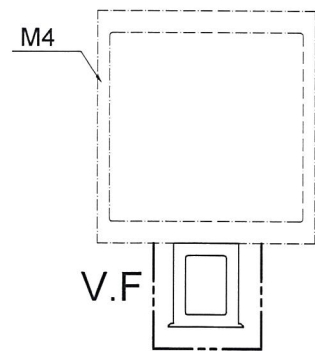
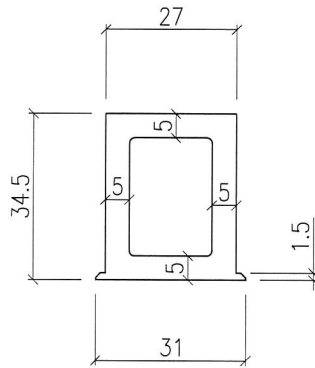

SCALE 1:2

| | | | | | | | | | |
|--------------------|-------------------------|-----------------------|------------------|----------------|------------|----------|---------|---------|-----|
| SIGNATURE GRADEING | HIGH SIGNATURE GRADEING | C.C.DIA(MM) | | | | | | | |
| AREA (SQ MM) | 521 | UNSPECIFIED THICKNESS | - | PERIMETER (MM) | - | STANDARD | | SCALE | 1:1 |
| MASS (KG/M) | - | UNSPECIFIED CORNERS | - | SURFACE AREA | - | ALLOY | 6063 T6 | VERSION | |
| COMPANY ISSUE | | | DRAWA | DATE | APELLATION | - | PAGE OF | | |
| | | | STANDAR-DIZATION | DATE | | | | | |
| | | | TO SIGN | DATE | | | | | |
| | | | AUDITING | DATE | | | | | |
| MARKER | MODIFY | FILE NO | SIGNATURE | DATE | APPROV | | | | |

美特鋁質有限公司
 MIDI Aluminium Fabricator Ltd.

5

| | | | | | |
|----------|--|-------------------|--|---------------|--------|
| CUSTOMER | | CUSTOMER APPROVAL | | CUST PART NO. | M4 |
| | | | | SECTION NO. | X85548 |

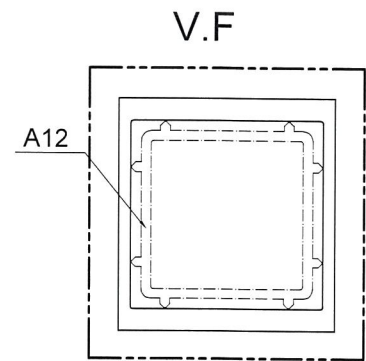
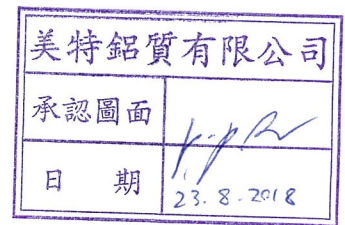
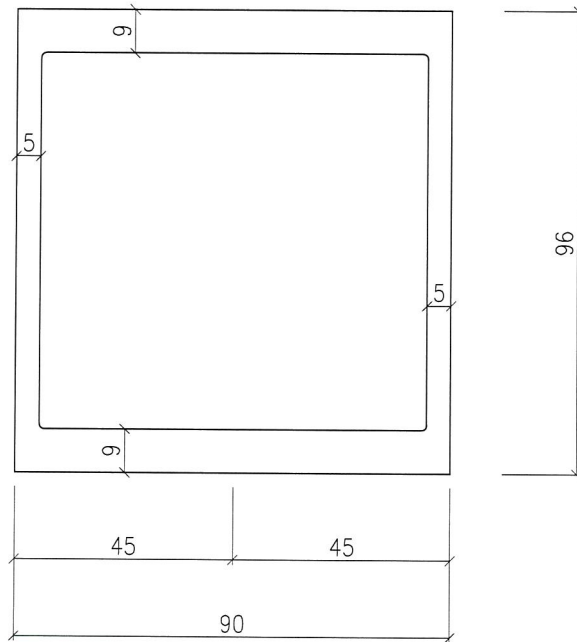



SCALE 1:2

| | | | | | | | | | |
|--------------------|-------------------------|-----------------------|-----------------|----------------|------------|----------|---------|---------|-----|
| SIGNATURE GRADEING | HIGH SIGNATURE GRADEING | C.C.DIA(MM) | | | | | | | |
| AREA (SQ MM) | 2400.9 | UNSPECIFIED THICKNESS | - | PERIMETER (MM) | - | STANDARD | | SCALE | 1:1 |
| MASS (KG/M) | - | UNSPECIFIED CORNERS | - | SURFACE AREA | - | ALLOY | 6063 T6 | VERSION | |
| COMPANY ISSUE | | | DRAWN | DATE | APELLATION | - | PAGE OF | | |
| | | | STANDARDIZATION | DATE | | | | | |
| | | | TO SIGN | DATE | | | | | |
| | | | AUDITING | DATE | | | | | |
| MARKER | MODIFY | FILE NO | SIGNATURE | DATE | APPROV | | | | |

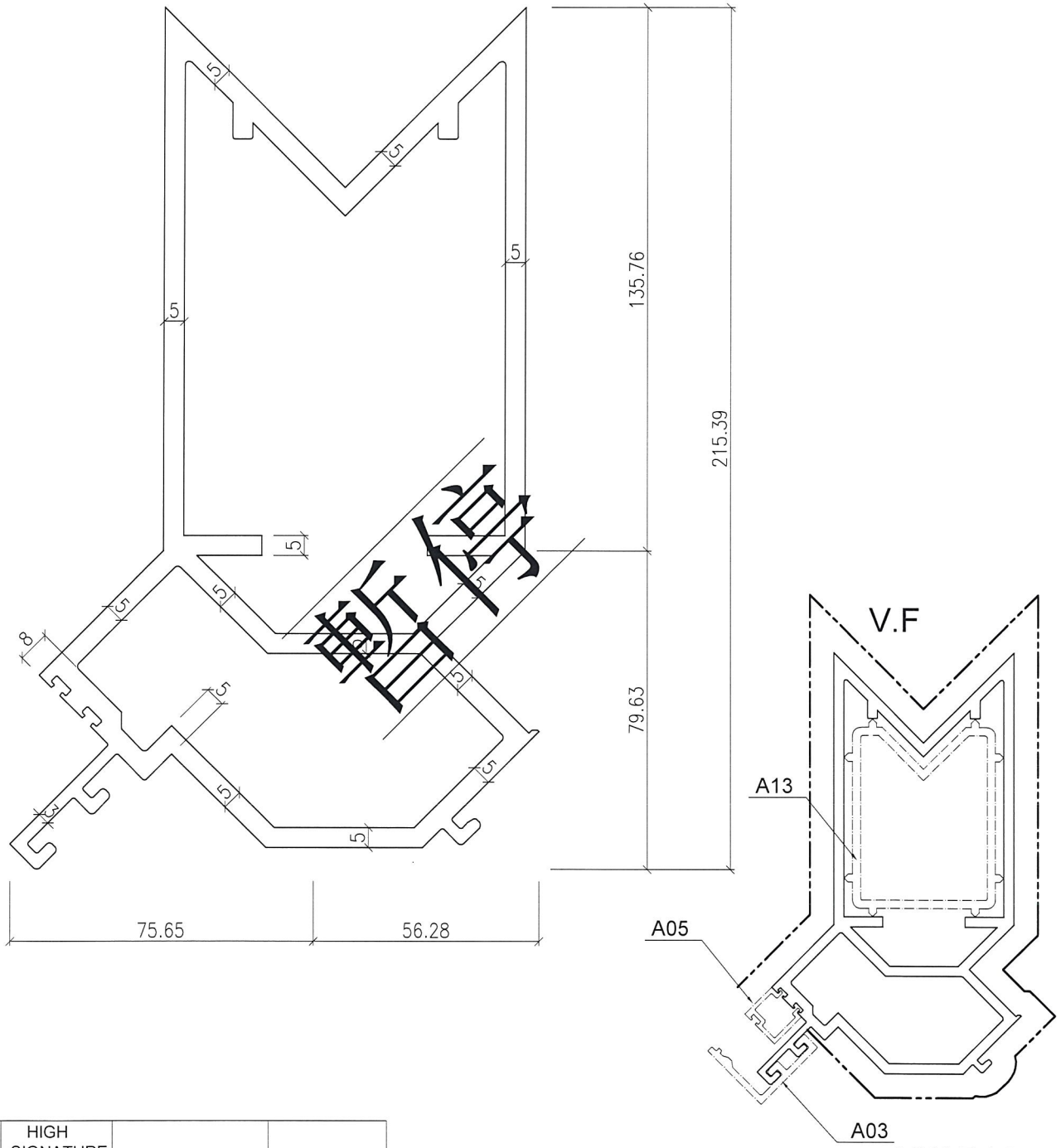

美特鋁質有限公司
 MIDI Aluminium Fabricator Ltd.

| | | | |
|----------|-------------------|---------------|--------|
| CUSTOMER | CUSTOMER APPROVAL | CUST PART NO. | M5 |
| | | SECTION NO. | X85549 |

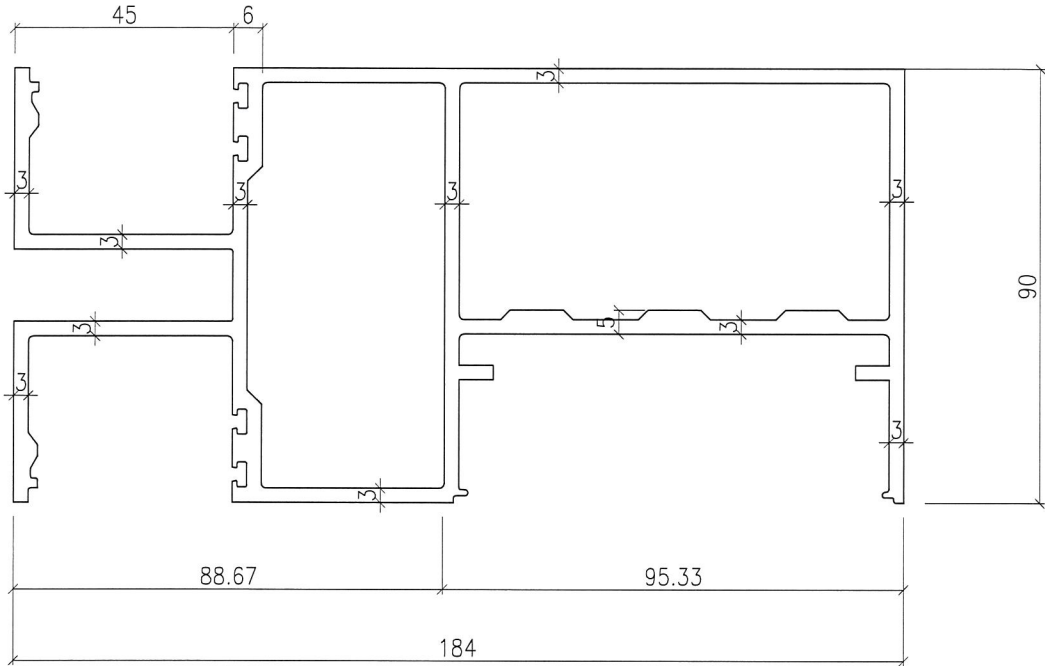

| | | | | | | | | | |
|--------------------|-------------------------|-----------------------|-----------------|----------------|---|----------|---------|---------|-----|
| SIGNATURE GRADEING | HIGH SIGNATURE GRADEING | C.C.DIA(MM) | | | | | | | |
| AREA (SQ MM) | 4006.3 | UNSPECIFIED THICKNESS | - | PERIMETER (MM) | - | STANDARD | | SCALE | 1:1 |
| MASS (KG/M) | - | UNSPECIFIED CORNERS | - | SURFACE AREA | - | ALLOY | 6063 T6 | VERSION | |
| COMPANY ISSUE | | | DRAWN | DATE | APPELLATION | | - | PAGE OF | |
| | | | STANDARDIZATION | DATE |  美特鋁質有限公司 MIDI Aluminium Fabricator Ltd. | | | | |
| | | | TO SIGN | DATE | | | | | |
| | | | AUDITING | DATE | | | | | |
| MARKER | MODIFY | FILE NO | SIGNATURE | DATE | | | | | |

| | | | |
|----------|-------------------|---------------|--------|
| CUSTOMER | CUSTOMER APPROVAL | CUST PART NO. | T1 |
| | | SECTION NO. | X85552 |



| | |
|----------|--------------------|
| 美特鋁質有限公司 | |
| 承認圖面 | <i>[Signature]</i> |
| 日期 | 23-8-2018 |

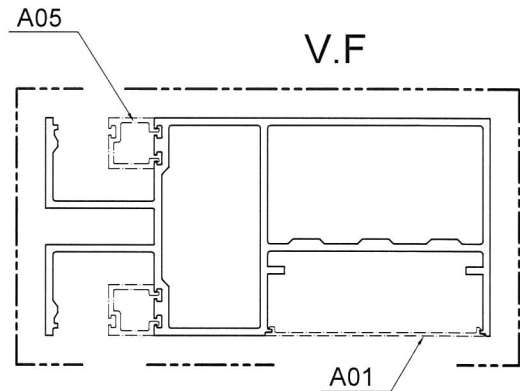

SCALE 1:2

| | | | | | | | | | |
|--------------------|-------------------------|-----------------------|-----------------|----------------|-------------|----------|---------|---------|-----|
| SIGNATURE GRADEING | HIGH SIGNATURE GRADEING | C.C.DIA(MM) | | | | | | | |
| AREA (SQ MM) | 2283.0 | UNSPECIFIED THICKNESS | - | PERIMETER (MM) | - | STANDARD | | SCALE | 1:1 |
| MASS (KG/M) | - | UNSPECIFIED CORNERS | - | SURFACE AREA | - | ALLOY | 6063 T6 | VERSION | |
| COMPANY ISSUE | | | DRAWN | DATE | APPELLATION | | - | PAGE OF | |
| | | | STANDARDIZATION | DATE | | | | | |
| | | | TO SIGN | DATE | | | | | |
| | | | AUDITING | DATE | | | | | |
| MARKER | MODIFY | FILE NO | SIGNATURE | DATE | APPROV | | | | |



美特鋁質有限公司
 MIDI Aluminium Fabricator Ltd.

[Handwritten mark]

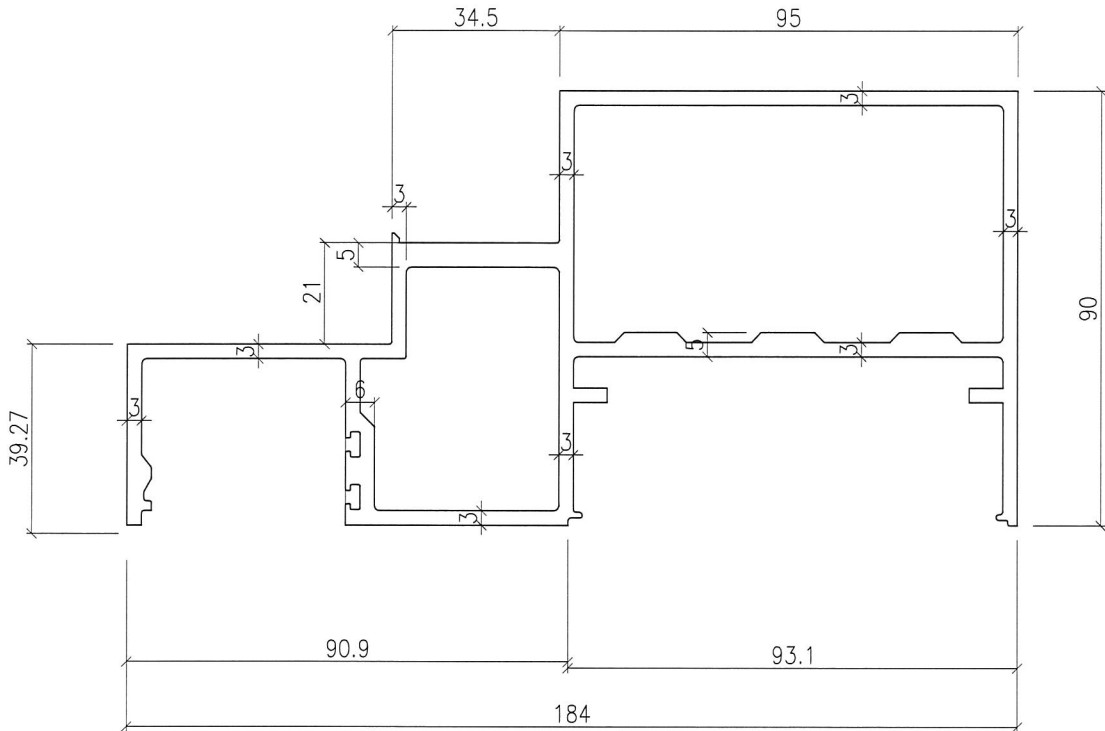
| | | | |
|----------|-------------------|---------------|--------|
| CUSTOMER | CUSTOMER APPROVAL | CUST PART NO. | T2 |
| | | SECTION NO. | X85553 |

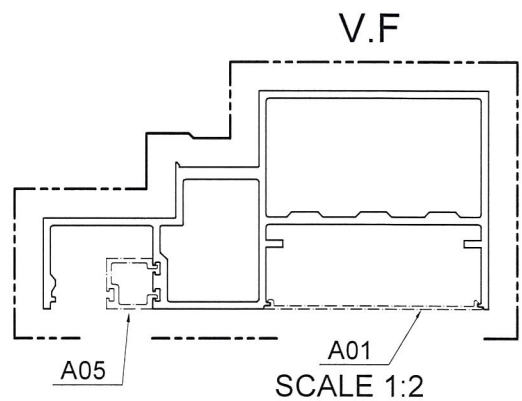

美特鋁質有限公司
承認圖面
日期 23. 8. 2018



| | | | | | | | | | |
|--------------------|-------------------------|-----------------------|-----------------|----------------|-------------|----------|---------|---------|-----|
| SIGNATURE GRADEING | HIGH SIGNATURE GRADEING | C.C.DIA(MM) | | | | | | | |
| AREA (SQ MM) | 1969.2 | UNSPECIFIED THICKNESS | - | PERIMETER (MM) | - | STANDARD | | SCALE | 1:1 |
| MASS (KG/M) | - | UNSPECIFIED CORNERS | - | SURFACE AREA | - | ALLOY | 6063 T6 | VERSION | |
| COMPANY ISSUE | | | DRAWN | DATE | APPELLATION | | - | PAGE OF | |
| | | | STANDARDIZATION | DATE | | | | | |
| | | | TO SIGN | DATE | | | | | |
| | | | AUDITING | DATE | | | | | |
| MARKER | MODIFY | FILE NO | SIGNATURE | DATE | APPROV | DATE | | | |

美特鋁質有限公司
MIDI Aluminium Fabricator Ltd.

| | | | |
|----------|-------------------|---------------|--------|
| CUSTOMER | CUSTOMER APPROVAL | CUST PART NO. | T3A |
| | | SECTION NO. | X85555 |

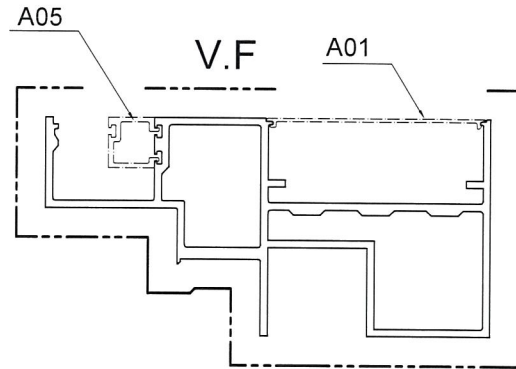
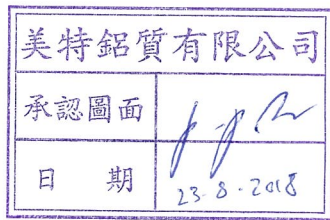
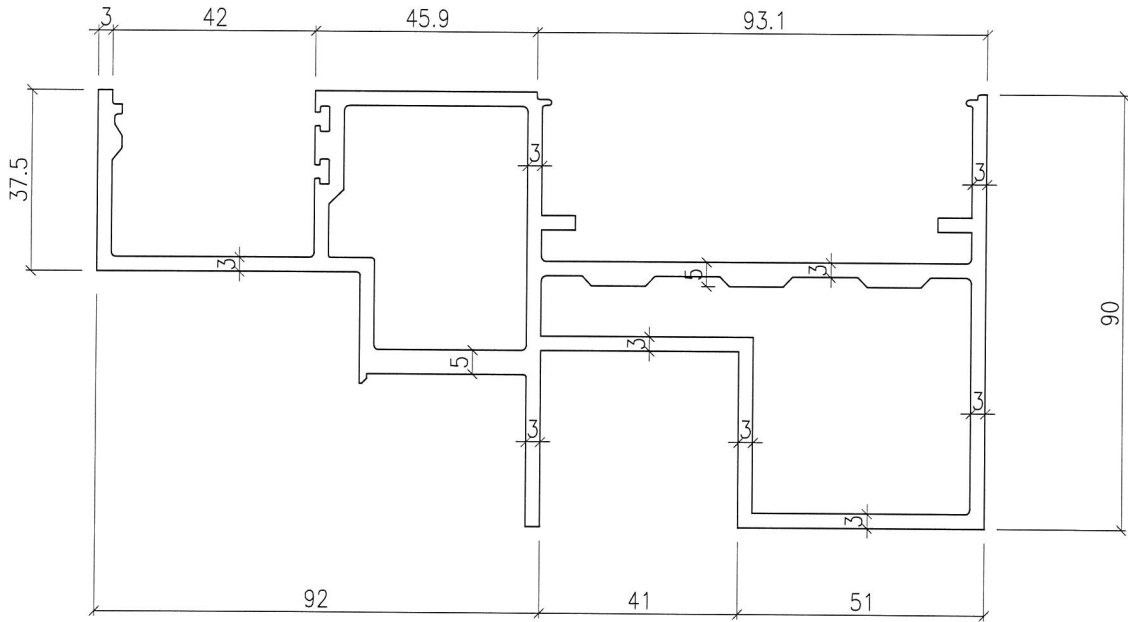

SCALE 1:2

| | | | | | | | | | |
|--------------------|-------------------------|-----------------------|------------------|----------------|------------|----------|---------|---------|-----|
| SIGNATURE GRADEING | HIGH SIGNATURE GRADEING | C.C.DIA(MM) | | | | | | | |
| AREA (SQ MM) | 2078.4 | UNSPECIFIED THICKNESS | - | PERIMETER (MM) | - | STANDARD | | SCALE | 1:1 |
| MASS (KG/M) | - | UNSPECIFIED CORNERS | - | SURFACE AREA | - | ALLOY | 6063 T6 | VERSION | |
| COMPANY ISSUE | | | DRAWA | DATE | APELLATION | - | PAGE OF | | |
| | | | STANDA-RDIZATION | DATE | | | | | |
| | | | TO SIGN | DATE | | | | | |
| | | | AUDITING | DATE | | | | | |
| MARKER | MODIFY | FILE NO | SIGNATURE | DATE | APPROV | | | | |

美特鋁質有限公司
MIDI Aluminium Fabricator Ltd.

| | | | |
|----------|-------------------|---------------|--------|
| CUSTOMER | CUSTOMER APPROVAL | CUST PART NO. | A01 |
| | | SECTION NO. | X85556 |

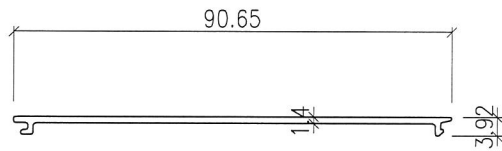

| | |
|----------|--------------------|
| 美特鋁質有限公司 | |
| 承認圖面 | <i>[Signature]</i> |
| 日期 | 23-8-2018 |

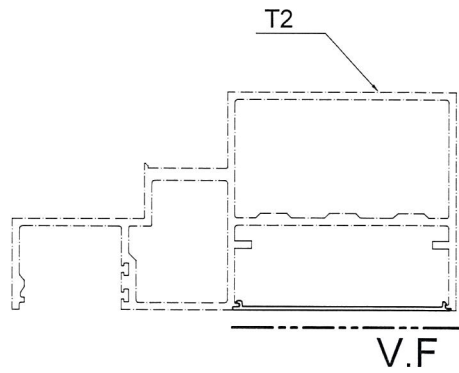

SCALE 1:2

| | | | | | | | | | |
|--------------------|-------------------------|-----------------------|-----------------|----------------|---|----------|---------|---------|-----|
| SIGNATURE GRADEING | HIGH SIGNATURE GRADEING | C.C.DIA(MM) | | | | | | | |
| AREA (SQ MM) | 132.6 | UNSPECIFIED THICKNESS | - | PERIMETER (MM) | - | STANDARD | | SCALE | 1:1 |
| MASS (KG/M) | - | UNSPECIFIED CORNERS | - | SURFACE AREA | - | ALLOY | 6063 T5 | VERSION | |
| COMPANY ISSUE | | | DRAWN | DATE | APPELLATION | | - | PAGE OF | |
| | | | STANDARDIZATION | DATE |  美特鋁質有限公司 MIDI Aluminium Fabricator Ltd. | | | | |
| | | | TO SIGN | DATE | | | | | |
| | | | AUDITING | DATE | | | | | |
| MARKER | MODIFY | FILE NO | SIGNATURE | DATE | | | | | |

12

| | | | |
|----------|-------------------|---------------|--------|
| CUSTOMER | CUSTOMER APPROVAL | CUST PART NO. | A02 |
| | | SECTION NO. | X85557 |

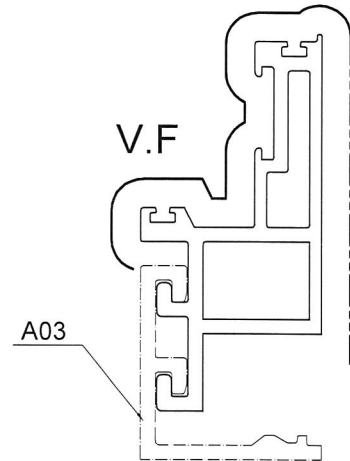
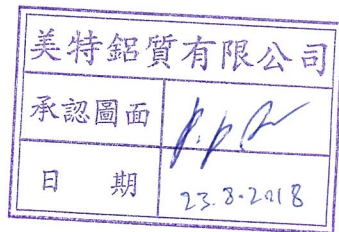
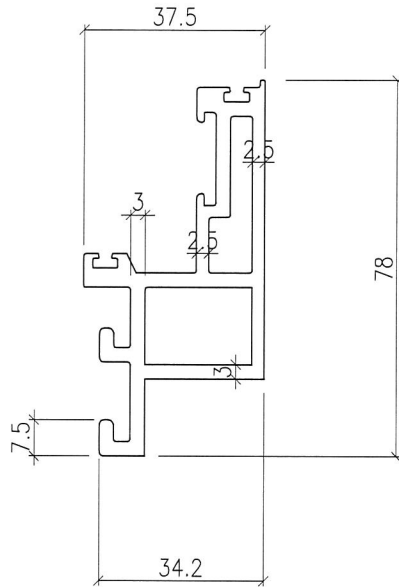

SCALE 1:1

| | | | | | | | | | |
|--------------------|-------------------------|-----------------------|-----------------|----------------|-------------|----------|---------|---------|-----|
| SIGNATURE GRADEING | HIGH SIGNATURE GRADEING | C.C.DIA(MM) | | | | | | | |
| AREA (SQ MM) | 680.9 | UNSPECIFIED THICKNESS | - | PERIMETER (MM) | - | STANDARD | | SCALE | 1:1 |
| MASS (KG/M) | - | UNSPECIFIED CORNERS | - | SURFACE AREA | - | ALLOY | 6063 T6 | VERSION | |
| COMPANY ISSUE | | | DRAWN | DATE | APPELLATION | - | PAGE OF | | |
| | | | STANDARDIZATION | DATE | | | | | |
| | | | TO SIGN | DATE | | | | | |
| | | | AUDITING | DATE | | | | | |
| MARKER | MODIFY | FILE NO | SIGNATURE | DATE | APPROV | | | | |

美特鋁質有限公司
 MIDI Aluminium Fabricator Ltd.

| | | | |
|----------|-------------------|---------------|--------|
| CUSTOMER | CUSTOMER APPROVAL | CUST PART NO. | A03 |
| | | SECTION NO. | X85558 |

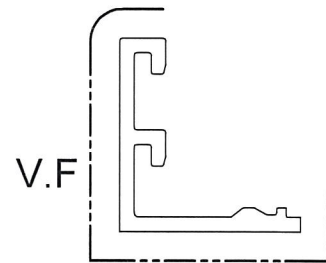
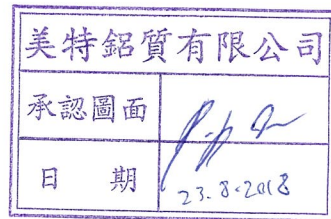
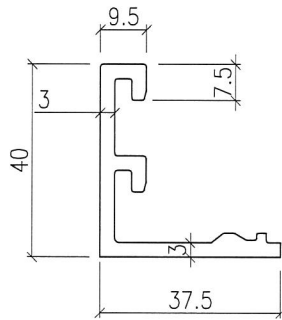

SCALE 1:1

| | | | | | | | | | |
|--------------------|-------------------------|-----------------------|-----------------|----------------|---|----------|---------|---------|------|
| SIGNATURE GRADEING | HIGH SIGNATURE GRADEING | C.C.DIA(MM) | | | | | | | |
| AREA (SQ MM) | 304.3 | UNSPECIFIED THICKNESS | - | PERIMETER (MM) | - | STANDARD | | SCALE | 1:1 |
| MASS (KG/M) | - | UNSPECIFIED CORNERS | - | SURFACE AREA | - | ALLOY | 6063 T6 | VERSION | |
| COMPANY ISSUE | | | DRAWN | DATE | APPELLATION | | - | PAGE OF | |
| | | | STANDARDIZATION | DATE |  美特鋁質有限公司 MIDI Aluminium Fabricator Ltd. | | | | |
| | | | TO SIGN | DATE | | | | | |
| | | | AUDITING | DATE | | | | | |
| MARKER | MODIFY | FILE NO | SIGNATURE | DATE | APPROV | | | | DATE |

| | | | | |
|----------|--|-------------------|---------------|--------|
| CUSTOMER | | CUSTOMER APPROVAL | CUST PART NO. | A04 |
| | | | SECTION NO. | X85559 |

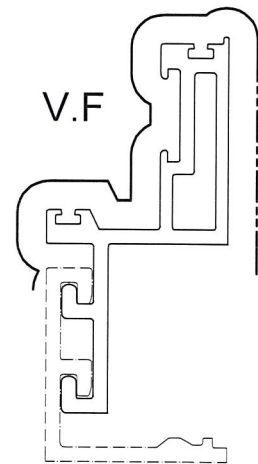
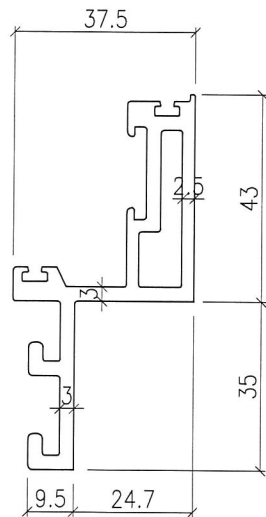

SCALE 1:1



| | | | | | | | | | |
|--------------------|-------------------------|-----------------------|-----------------|----------------|------------|----------|---------|---------|-----|
| SIGNATURE GRADEING | HIGH SIGNATURE GRADEING | C.C.DIA(MM) | | | | | | | |
| AREA (SQ MM) | 566.8 | UNSPECIFIED THICKNESS | - | PERIMETER (MM) | - | STANDARD | | SCALE | 1:1 |
| MASS (KG/M) | - | UNSPECIFIED CORNERS | - | SURFACE AREA | - | ALLOY | 6063 T6 | VERSION | |
| COMPANY ISSUE | | | DRAWN | DATE | APELLATION | - | PAGE OF | | |
| | | | STANDARDIZATION | DATE | | | | | |
| | | | TO SIGN | DATE | | | | | |
| | | | AUDITING | DATE | | | | | |
| MARKER | MODIFY | FILE NO | SIGNATURE | DATE | APPROV | | | | |

美特鋁質有限公司
 MIDI Aluminium Fabricator Ltd.

15

| | | | |
|----------|-------------------|---------------|--------|
| CUSTOMER | CUSTOMER APPROVAL | CUST PART NO. | A05 |
| | | SECTION NO. | X85560 |

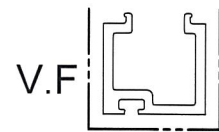
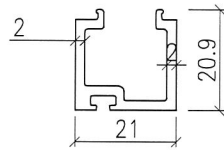

SCALE 1:1

| | | | | | | | | | |
|--------------------|-------------------------|-----------------------|-----------------|----------------|--|----------|---------|---------|-----|
| SIGNATURE GRADEING | HIGH SIGNATURE GRADEING | C.C.DIA(MM) | | | | | | | |
| AREA (SQ MM) | 138.3 | UNSPECIFIED THICKNESS | - | PERIMETER (MM) | - | STANDARD | | SCALE | 1:1 |
| MASS (KG/M) | - | UNSPECIFIED CORNERS | - | SURFACE AREA | - | ALLOY | 6063 T6 | VERSION | |
| COMPANY ISSUE | | | DRAWN | DATE | APELLATION | - | PAGE OF | | |
| | | | STANDARDIZATION | DATE | 美特鋁質有限公司 MIDI Aluminium Fabricator Ltd. | | | | |
| | | | TO SIGN | DATE | | | | | |
| | | | AUDITING | DATE | | | | | |
| MARKER | MODIFY | FILE NO | SIGNATURE | DATE | | | | | |

| | | | | |
|----------|--|-------------------|---------------|--------|
| CUSTOMER | | CUSTOMER APPROVAL | CUST PART NO. | A06 |
| | | | SECTION NO. | X85561 |

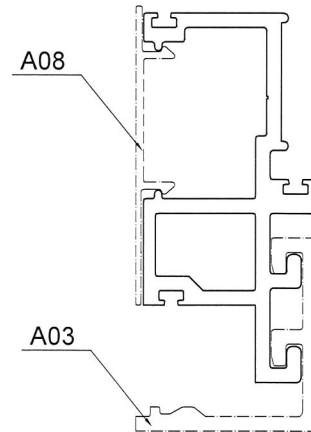
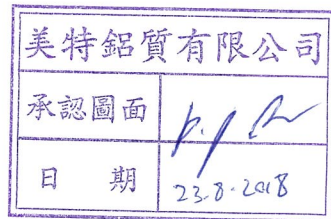
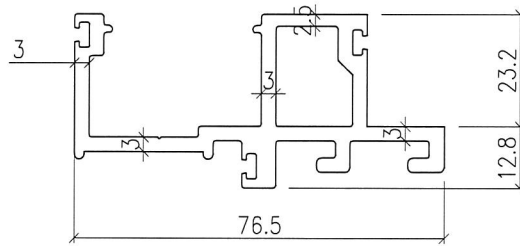

SCALE 1:1

| | | | | | | | | | |
|--------------------|-------------------------|-----------------------|-----------------|----------------|--------|------------|---------|---------|-----|
| SIGNATURE GRADEING | HIGH SIGNATURE GRADEING | C.C.DIA(MM) | | | | | | | |
| AREA (SQ MM) | 646.3 | UNSPECIFIED THICKNESS | - | PERIMETER (MM) | - | STANDARD | | SCALE | 1:1 |
| MASS (KG/M) | - | UNSPECIFIED CORNERS | - | SURFACE AREA | - | ALLOY | 6063 T6 | VERSION | |
| COMPANY ISSUE | | | DRAWN | | DATE | APELLATION | - | PAGE OF | |
| | | | STANDARDIZATION | | DATE | | | | |
| | | | TO SIGN | | DATE | | | | |
| | | | AUDITING | | DATE | | | | |
| MARKER | MODIFY | FILE NO | SIGNATURE | DATE | APPROV | | | | |

美特鋁質有限公司
 MIDI Aluminium Fabricator Ltd.

| | | | |
|----------|-------------------|---------------|--------|
| CUSTOMER | CUSTOMER APPROVAL | CUST PART NO. | A07 |
| | | SECTION NO. | X85562 |

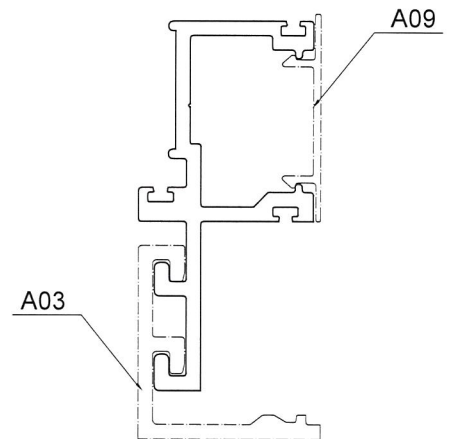
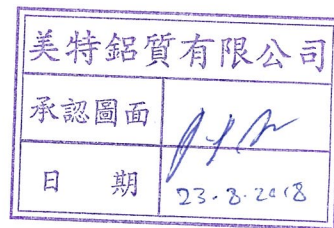
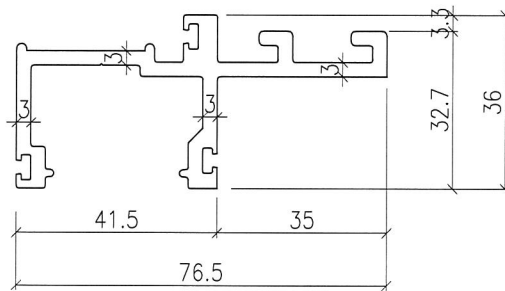

SCALE 1:1

| | | | | | | | | | |
|---------------|----------------|-----------------------|-----------------|----------------|--------|---|---------|---------|-----|
| SIGNATURE | HIGH SIGNATURE | C.C.DIA(MM) | | | | | | | |
| GRADEING | GRADEING | | | | | | | | |
| AREA (SQ MM) | 544.1 | UNSPECIFIED THICKNESS | - | PERIMETER (MM) | - | STANDARD | | SCALE | 1:1 |
| MASS (KG/M) | - | UNSPECIFIED CORNERS | - | SURFACE AREA | - | ALLOY | 6063 T6 | VERSION | |
| COMPANY ISSUE | | | DRAWN | | DATE | APPELLATION | - | PAGE OF | |
| | | | STANDARDIZATION | | DATE |  美特鋁質有限公司 MIDI Aluminium Fabricator Ltd. | | | |
| | | | TO SIGN | | DATE | | | | |
| | | | AUDITING | | DATE | | | | |
| MARKER | MODIFY | FILE NO | SIGNATURE | DATE | APPROV | | | | |

Handwritten mark

| | | | |
|----------|-------------------|---------------|--------|
| CUSTOMER | CUSTOMER APPROVAL | CUST PART NO. | A08 |
| | | SECTION NO. | X85563 |

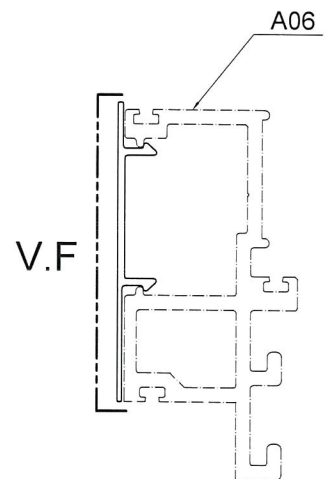
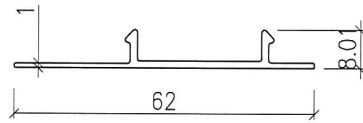

SCALE 1:1

| | | | | | | | | | |
|--------------------|-------------------------|-----------------------|-------------------|----------------|------------|----------|---------|---------|-----|
| SIGNATURE GRADEING | HIGH SIGNATURE GRADEING | C.C.DIA(MM) | | | | | | | |
| AREA (SQ MM) | 99.3 | UNSPECIFIED THICKNESS | - | PERIMETER (MM) | - | STANDARD | | SCALE | 1:1 |
| MASS (KG/M) | - | UNSPECIFIED CORNERS | - | SURFACE AREA | - | ALLOY | 6063 T5 | VERSION | |
| COMPANY ISSUE | | | DRAWA | DATE | APELLATION | - | PAGE OF | | |
| | | | STANDA- RDIZATION | DATE | | | | | |
| | | | TO SIGN | DATE | | | | | |
| | | | AUDITING | DATE | | | | | |
| MARKER | MODIFY | FILE NO | SIGNATURE | DATE | APPROV | | | | |

美特鋁質有限公司
 MIDI Aluminium Fabricator Ltd.

| | | | |
|----------|-------------------|---------------|--------|
| CUSTOMER | CUSTOMER APPROVAL | CUST PART NO. | A09 |
| | | SECTION NO. | X85564 |

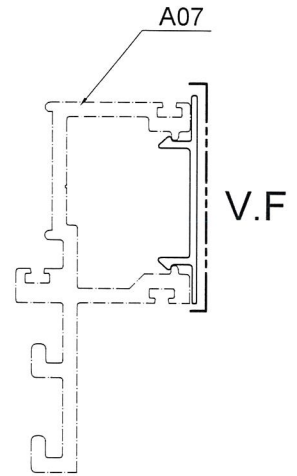
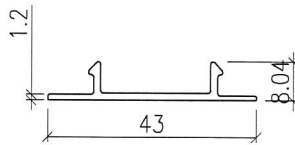

SCALE 1:1

| | | | | | | | | | |
|--------------------|-------------------------|-----------------------|-----------------|----------------|---|----------|---------|---------|-----|
| SIGNATURE GRADEING | HIGH SIGNATURE GRADEING | C.C.DIA(MM) | | | | | | | |
| AREA (SQ MM) | 78.8 | UNSPECIFIED THICKNESS | - | PERIMETER (MM) | - | STANDARD | | SCALE | 1:1 |
| MASS (KG/M) | - | UNSPECIFIED CORNERS | - | SURFACE AREA | - | ALLOY | 6063 T5 | VERSION | |
| COMPANY ISSUE | | | DRAWN | DATE | APPELLATION | - | PAGE OF | | |
| | | | STANDARDIZATION | DATE | 美特鋁質有限公司 MIDI Aluminium Fabricator Ltd. | | | | |
| | | | TO SIGN | DATE | | | | | |
| | | | AUDITING | DATE | | | | | |
| MARKER | MODIFY | FILE NO | SIGNATURE | DATE | | | | | |

| | | | | |
|----------|--|-------------------|---------------|--------|
| CUSTOMER | | CUSTOMER APPROVAL | CUST PART NO. | A10 |
| | | | SECTION NO. | X85565 |

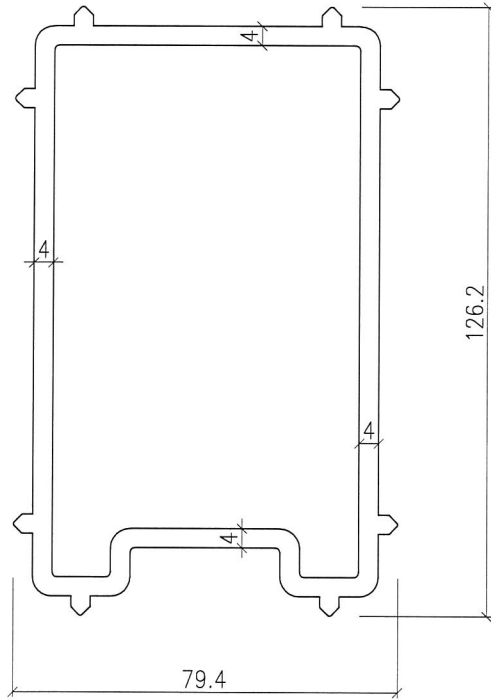

| | |
|----------|--------------------|
| 美特鋁質有限公司 | |
| 承認圖面 | <i>[Signature]</i> |
| 日期 | 23.7.2018 |

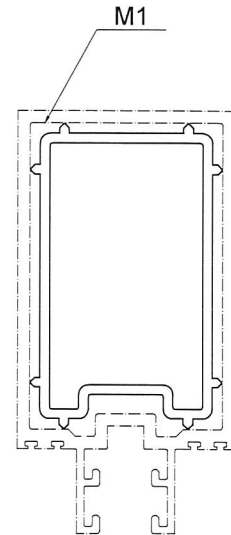

SCALE 1:1

| | | | | | | | | | |
|--------------------|-------------------------|-----------------------|-----------------|----------------|-------------|----------|---------|---------|-----|
| SIGNATURE GRADEING | HIGH SIGNATURE GRADEING | C.C.DIA(MM) | | | | | | | |
| AREA (SQ MM) | 1610.0 | UNSPECIFIED THICKNESS | - | PERIMETER (MM) | - | STANDARD | | SCALE | 1:1 |
| MASS (KG/M) | - | UNSPECIFIED CORNERS | - | SURFACE AREA | - | ALLOY | 6061 T6 | VERSION | |
| COMPANY ISSUE | | | DRAWN | DATE | APPELLATION | | - | PAGE OF | |
| | | | STANDARDIZATION | DATE | | | | | |
| | | | TO SIGN | DATE | | | | | |
| | | | AUDITING | DATE | | | | | |
| MARKER | MODIFY | FILE NO | SIGNATURE | DATE | APPROV | DATE | | | |

美特鋁質有限公司
 MIDI Aluminium Fabricator Ltd.

| | | | |
|----------|-------------------|---------------|--------|
| CUSTOMER | CUSTOMER APPROVAL | CUST PART NO. | A11 |
| | | SECTION NO. | X83566 |

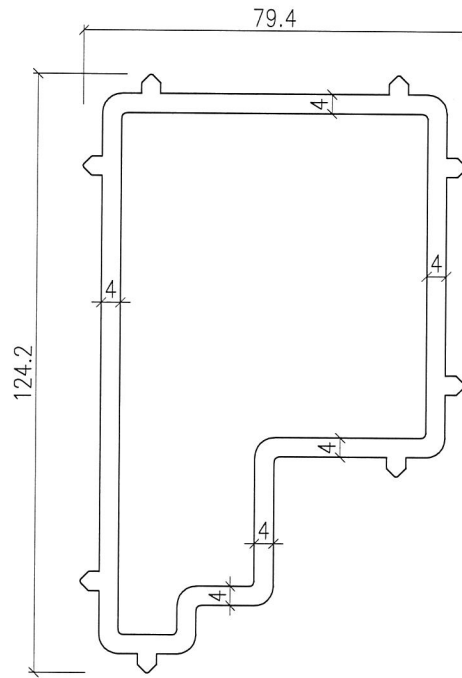

| | |
|----------|---------------|
| 美特鋁質有限公司 | |
| 承認圖面 | <i>J.P.A.</i> |
| 日期 | 23.8.2018 |

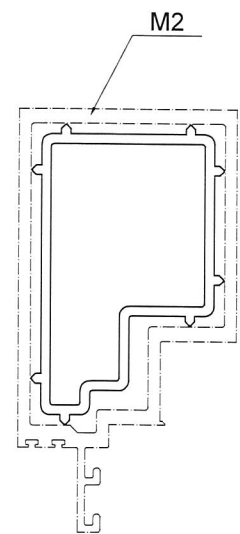

| | | | | | | | | | |
|--------------------|-------------------------|-----------------------|-----------------|----------------|------------|----------|---------|---------|-----|
| SIGNATURE GRADEING | HIGH SIGNATURE GRADEING | C.C.DIA(MM) | | | | | | | |
| AREA (SQ MM) | 1513.2 | UNSPECIFIED THICKNESS | - | PERIMETER (MM) | - | STANDARD | | SCALE | 1:1 |
| MASS (KG/M) | - | UNSPECIFIED CORNERS | - | SURFACE AREA | - | ALLOY | 6061 T6 | VERSION | |
| COMPANY ISSUE | | | DRAWN | DATE | APELLATION | - | PAGE OF | | |
| | | | STANDARDIZATION | DATE | | | | | |
| | | | TO SIGN | DATE | | | | | |
| | | | AUDITING | DATE | | | | | |
| MARKER | MODIFY | FILE NO | SIGNATURE | DATE | APPROV | | | | |

美特鋁質有限公司
 MIDI Aluminium Fabricator Ltd.

| | | | |
|----------|-------------------|---------------|--------|
| CUSTOMER | CUSTOMER APPROVAL | CUST PART NO. | A12 |
| | | SECTION NO. | X85567 |

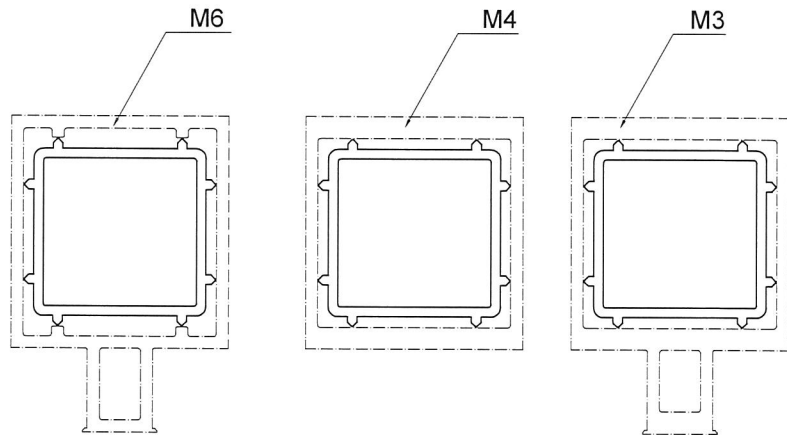
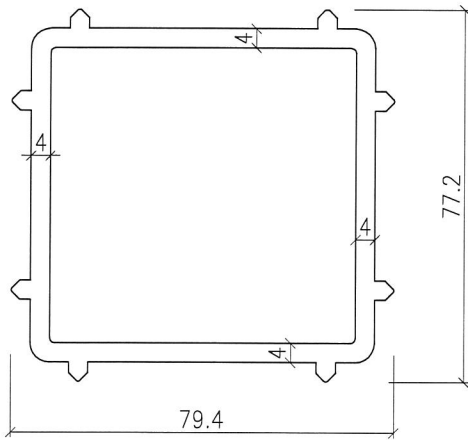

SCALE 1:2

| | | | | | | | | | |
|--------------------|-------------------------|-----------------------|-----------------|----------------|-------------|----------|---------|---------|-----|
| SIGNATURE GRADEING | HIGH SIGNATURE GRADEING | C.C.DIA(MM) | | | | | | | |
| AREA (SQ MM) | 1150.1 | UNSPECIFIED THICKNESS | - | PERIMETER (MM) | - | STANDARD | | SCALE | 1:1 |
| MASS (KG/M) | - | UNSPECIFIED CORNERS | - | SURFACE AREA | - | ALLOY | 6061 T6 | VERSION | |
| COMPANY ISSUE | | | DRAWN | DATE | APPELLATION | - | PAGE OF | | |
| | | | STANDARDIZATION | DATE | | | | | |
| | | | TO SIGN | DATE | | | | | |
| | | | AUDITING | DATE | | | | | |
| MARKER | MODIFY | FILE NO | SIGNATURE | DATE | APPROV | | | | |

美特鋁質有限公司
 MIDI Aluminium Fabricator Ltd.

| | | | |
|----------|-------------------|---------------|--------|
| CUSTOMER | CUSTOMER APPROVAL | CUST PART NO. | A13 |
| | | SECTION NO. | X85568 |

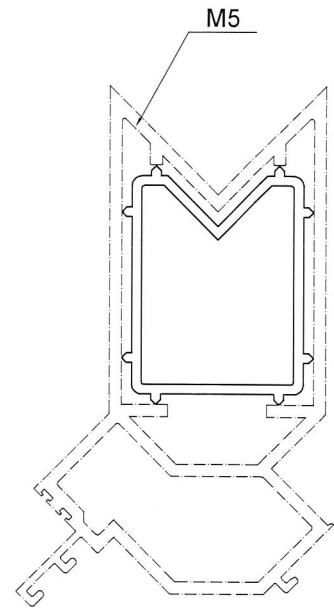
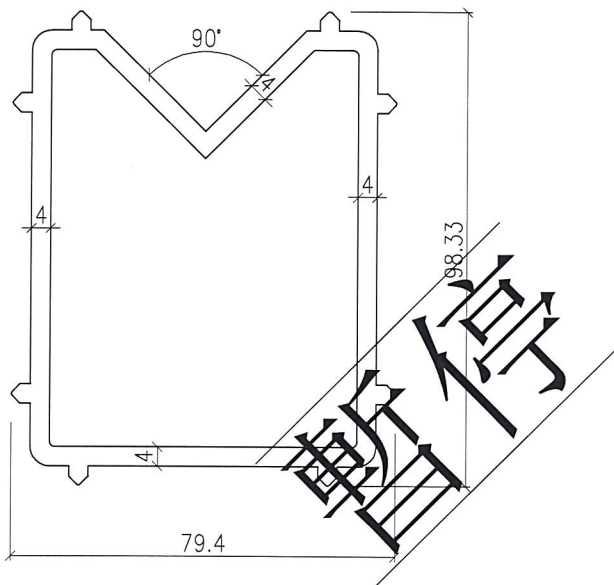

SCALE 1:2

| | | | | | | | | | |
|--------------------|-------------------------|-----------------------|------------------|----------------|---|----------|---------|---------|-----|
| SIGNATURE GRADEING | HIGH SIGNATURE GRADEING | C.C.DIA(MM) | | | | | | | |
| AREA (SQ MM) | 1391.1 | UNSPECIFIED THICKNESS | - | PERIMETER (MM) | - | STANDARD | | SCALE | 1:1 |
| MASS (KG/M) | - | UNSPECIFIED CORNERS | - | SURFACE AREA | - | ALLOY | 6061 T6 | VERSION | |
| COMPANY ISSUE | | | DRAWA | DATE | APELLATION | - | PAGE OF | | |
| | | | STANDA-RDIZATION | DATE |  美特铝质有限公司 MIDI Aluminium Fabricator Ltd. | | | | |
| | | | TO SIGN | DATE | | | | | |
| | | | AUDITING | DATE | | | | | |
| MARKER | MODIFY | FILE NO | SIGNATURE | DATE | | | | | |

| | | | |
|----------|-------------------|---------------|--------|
| CUSTOMER | CUSTOMER APPROVAL | CUST PART NO. | A14 |
| | | SECTION NO. | X85569 |

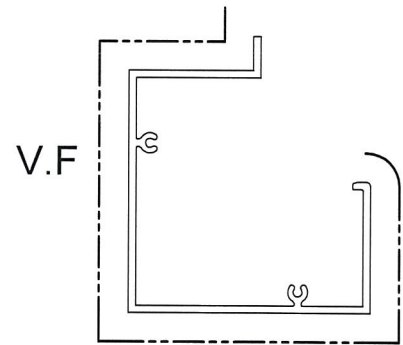
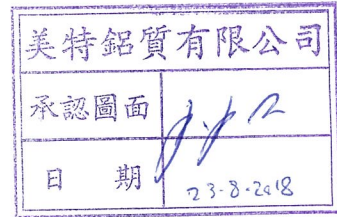
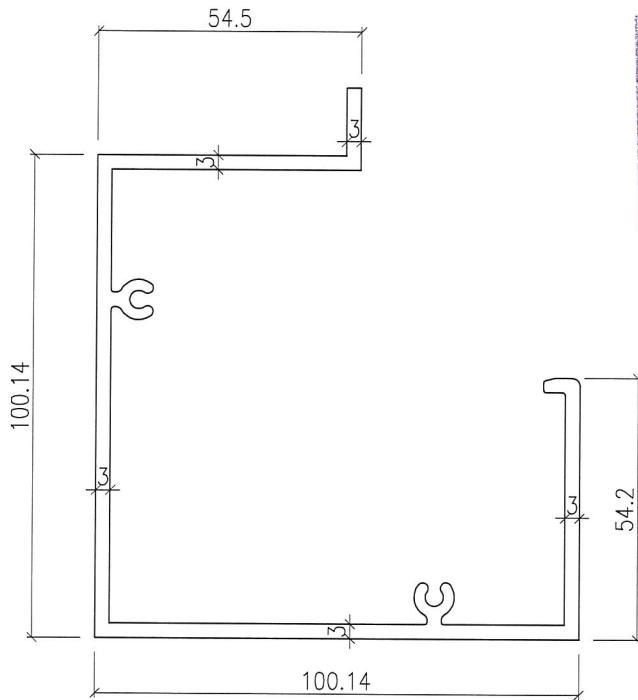

SCALE 1:2

| | | | | | | | | | |
|--------------------|-------------------------|-----------------------|-----------------|----------------|------------|----------|---------|---------|-----|
| SIGNATURE GRADEING | HIGH SIGNATURE GRADEING | C.C.DIA(MM) | | | | | | | |
| AREA (SQ MM) | 1035.4 | UNSPECIFIED THICKNESS | - | PERIMETER (MM) | - | STANDARD | | SCALE | 1:1 |
| MASS (KG/M) | - | UNSPECIFIED CORNERS | - | SURFACE AREA | - | ALLOY | 6061 T6 | VERSION | |
| COMPANY ISSUE | | | DRAWN | DATE | APELLATION | - | PAGE OF | | |
| | | | STANDARDIZATION | DATE | | | | | |
| | | | TO SIGN | DATE | | | | | |
| | | | AUDITING | DATE | | | | | |
| MARKER | MODIFY | FILE NO | SIGNATURE | DATE | APPROV | | | | |

美特鋁質有限公司
 MIDI Aluminium Fabricator Ltd.

| | | | | |
|----------|--|-------------------|---------------|--------|
| CUSTOMER | | CUSTOMER APPROVAL | CUST PART NO. | S01 |
| | | | SECTION NO. | X85570 |

| | |
|----------|--------------------|
| 美特鋁質有限公司 | |
| 承認圖面 | <i>[Signature]</i> |
| 日期 | 23-8-2018 |

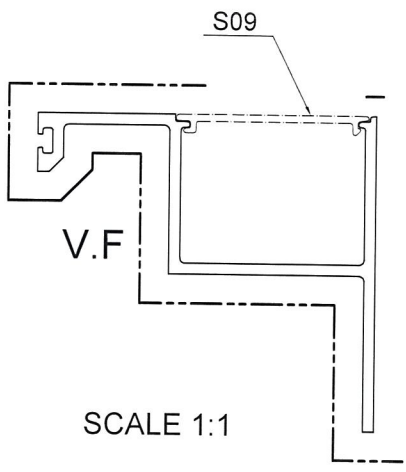
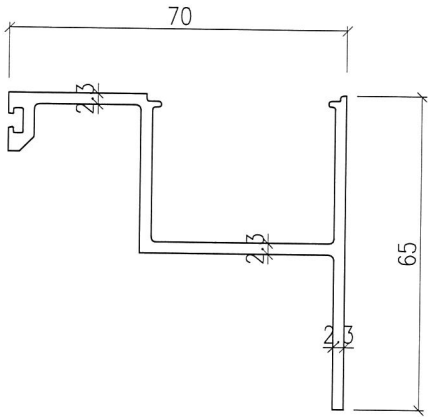

| | | | | | | | | | |
|--------------------|-------------------------|-----------------------|-----------------|----------------|-------------|----------|---------|---------|-----|
| SIGNATURE GRADEING | HIGH SIGNATURE GRADEING | C.C.DIA(MM) | | | | | | | |
| AREA (SQ MM) | 412.6 | UNSPECIFIED THICKNESS | - | PERIMETER (MM) | - | STANDARD | | SCALE | 1:1 |
| MASS (KG/M) | - | UNSPECIFIED CORNERS | - | SURFACE AREA | - | ALLOY | 6063 T6 | VERSION | |
| COMPANY ISSUE | | | DRAWN | DATE | APPELLATION | - | PAGE OF | | |
| | | | STANDARDIZATION | DATE | | | | | |
| | | | TO SIGN | DATE | | | | | |
| | | | AUDITING | DATE | | | | | |
| MARKER | MODIFY | FILE NO | SIGNATURE | DATE | APPROV | | | | |

美特鋁質有限公司
 MIDI Aluminium Fabricator Ltd.

| | | | | | |
|----------|--|-------------------|--|---------------|--------|
| CUSTOMER | | CUSTOMER APPROVAL | | CUST PART NO. | S02 |
| | | | | SECTION NO. | X85571 |

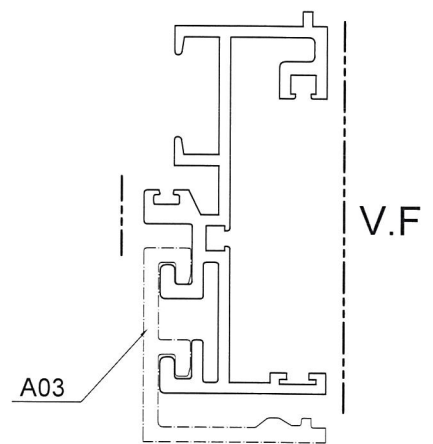
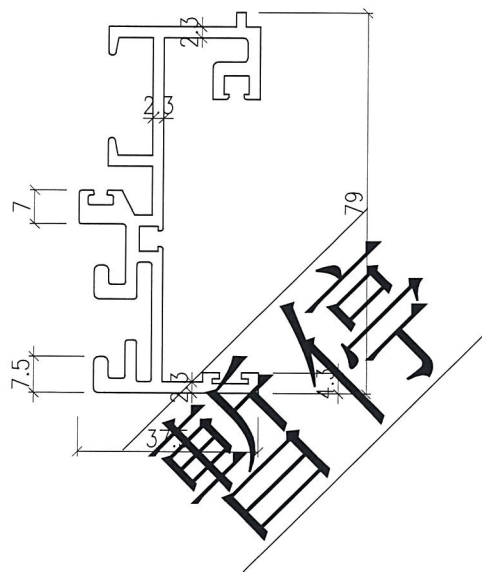

SCALE 1:1

| | | | | | | | | | |
|--------------------|-------------------------|-----------------------|-----------------|----------------|-------------|----------|---------|---------|-----|
| SIGNATURE GRADEING | HIGH SIGNATURE GRADEING | C. C. DIA(MM) | | | | | | | |
| AREA (SQ MM) | 602.1 | UNSPECIFIED THICKNESS | - | PERIMETER (MM) | - | STANDARD | | SCALE | 1:1 |
| MASS (KG/M) | - | UNSPECIFIED CORNERS | - | SURFACE AREA | - | ALLOY | 6063 T5 | VERSION | |
| COMPANY ISSUE | | | DRAWN | DATE | APPELLATION | - | PAGE OF | | |
| | | | STANDARDIZATION | DATE | | | | | |
| | | | TO SIGN | DATE | | | | | |
| | | | AUDITING | DATE | | | | | |
| MARKER | MODIFY | FILE NO | SIGNATURE | DATE | APPROV | | | | |

美特鋁質有限公司
 MIDI Aluminium Fabricator Ltd.

| | | | |
|----------|-------------------|---------------|---------|
| CUSTOMER | CUSTOMER APPROVAL | CUST PART NO. | S03 |
| | | SECTION NO. | X855 72 |

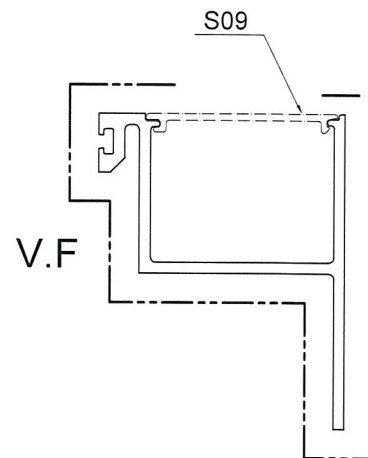
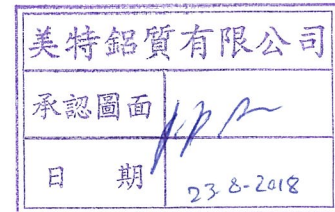
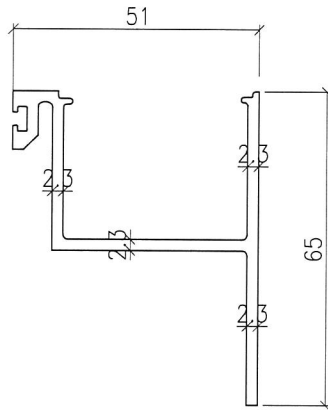

SCALE 1:1

| | | | | | | | | | |
|--------------------|-------------------------|-----------------------|------------------|----------------|------------|----------|---------|---------|-----|
| SIGNATURE GRADEING | HIGH SIGNATURE GRADEING | C.C.DIA(MM) | | | | | | | |
| AREA (SQ MM) | 368.9 | UNSPECIFIED THICKNESS | - | PERIMETER (MM) | - | STANDARD | | SCALE | 1:1 |
| MASS (KG/M) | - | UNSPECIFIED CORNERS | - | SURFACE AREA | - | ALLOY | 6063 T6 | VERSION | |
| COMPANY ISSUE | | | DRAWA | DATE | APELLATION | - | PAGE OF | | |
| | | | STANDA-RDIZATION | DATE | | | | | |
| | | | TO SIGN | DATE | | | | | |
| | | | AUDITING | DATE | | | | | |
| MARKER | MODIFY | FILE NO | SIGNATURE | DATE | APPROV | | | | |

美特鋁質有限公司
 MIDI Aluminium Fabricator Ltd.

28

| | | | |
|----------|-------------------|---------------|--------|
| CUSTOMER | CUSTOMER APPROVAL | CUST PART NO. | S04 |
| | | SECTION NO. | X85573 |

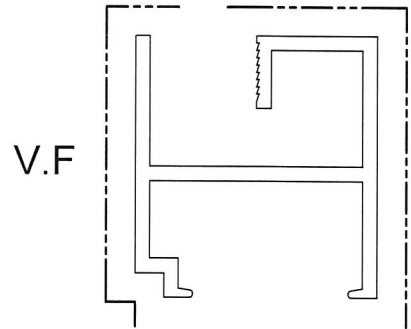
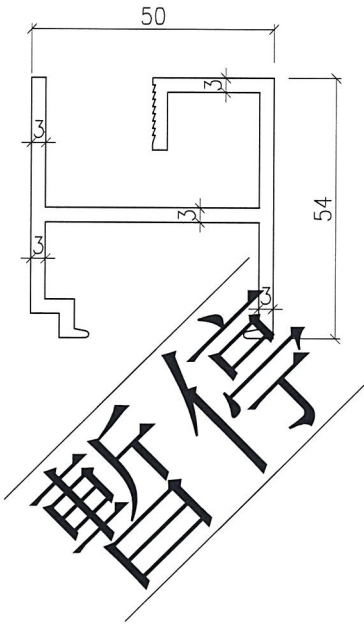

SCALE 1:1

| | | | | | | | | | |
|--------------------|-------------------------|-----------------------|-----------------|----------------|------------|----------|---------|---------|-----|
| SIGNATURE GRADEING | HIGH SIGNATURE GRADEING | C.C.DIA(MM) | | | | | | | |
| AREA (SQ MM) | 582.5 | UNSPECIFIED THICKNESS | - | PERIMETER (MM) | - | STANDARD | | SCALE | 1:1 |
| MASS (KG/M) | - | UNSPECIFIED CORNERS | - | SURFACE AREA | - | ALLOY | 6063 T6 | VERSION | |
| COMPANY ISSUE | | | DRAWN | DATE | APELLATION | - | PAGE OF | | |
| | | | STANDARDIZATION | DATE | | | | | |
| | | | TO SIGN | DATE | | | | | |
| | | | AUDITING | DATE | | | | | |
| MARKER | MODIFY | FILE NO | SIGNATURE | DATE | APPROV | | | | |

美特鋁質有限公司
 MIDI Aluminium Fabricator Ltd.

| | | | | | |
|----------|--|-------------------|--|---------------|--------|
| CUSTOMER | | CUSTOMER APPROVAL | | CUST PART NO. | S05 |
| | | | | SECTION NO. | X85574 |

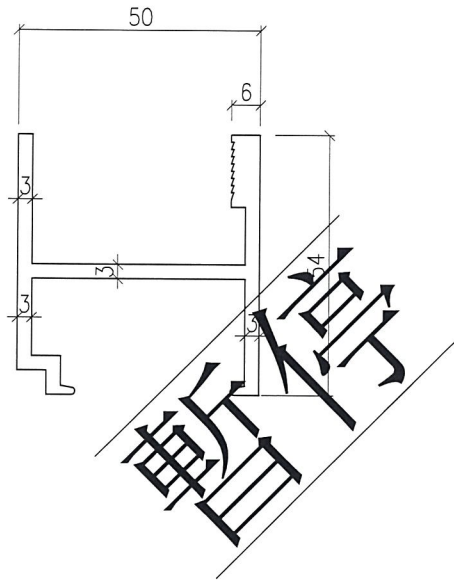

V.F

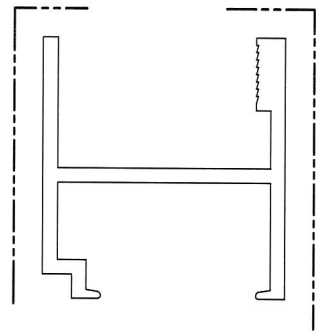

SCALE 1:1

| | | | | | | | | | |
|--------------------|-------------------------|-----------------------|-----------------|----------------|---|----------|---------|---------|-----|
| SIGNATURE GRADEING | HIGH SIGNATURE GRADEING | C.C.DIA(MM) | | | | | | | |
| AREA (SQ MM) | 525.5 | UNSPECIFIED THICKNESS | - | PERIMETER (MM) | - | STANDARD | | SCALE | 1:1 |
| MASS (KG/M) | - | UNSPECIFIED CORNERS | - | SURFACE AREA | - | ALLOY | 6063 T6 | VERSION | |
| COMPANY ISSUE | | | DRAWN | DATE | APPELLATION | - | PAGE OF | | |
| | | | STANDARDIZATION | DATE |  美特铝业有限公司 MIDI Aluminium Fabricator Ltd. | | | | |
| | | | TO SIGN | DATE | | | | | |
| | | | AUDITING | DATE | | | | | |
| MARKER | MODIFY | FILE NO | SIGNATURE | DATE | | | | | |

| | | | | |
|----------|--|-------------------|---------------|--------|
| CUSTOMER | | CUSTOMER APPROVAL | CUST PART NO. | S06 |
| | | | SECTION NO. | X85575 |

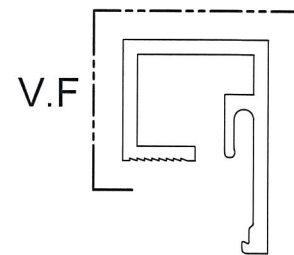
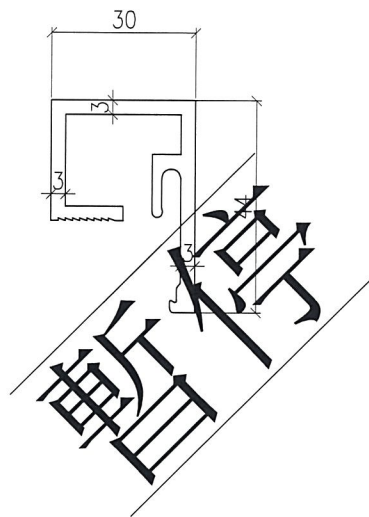

SCALE 1:1

| | | | | | | | | | |
|--------------------|-------------------------|-----------------------|-----------------|----------------|-------------|----------|---------|---------|-----|
| SIGNATURE GRADEING | HIGH SIGNATURE GRADEING | C.C.DIA(MM) | | | | | | | |
| AREA (SQ MM) | 359.2 | UNSPECIFIED THICKNESS | - | PERIMETER (MM) | - | STANDARD | | SCALE | 1:1 |
| MASS (KG/M) | - | UNSPECIFIED CORNERS | - | SURFACE AREA | - | ALLOY | 6063 T6 | VERSION | |
| COMPANY ISSUE | | | DRAWN | DATE | APPELLATION | | - | PAGE OF | |
| | | | STANDARDIZATION | DATE | | | | | |
| | | | TO SIGN | DATE | | | | | |
| | | | AUDITING | DATE | | | | | |
| MARKER | MODIFY | FILE NO | SIGNATURE | DATE | APPROV | | | | |

美特鋁質有限公司
 MIDI Aluminium Fabricator Ltd.

| | | | | | |
|----------|--|-------------------|--|---------------|--------|
| CUSTOMER | | CUSTOMER APPROVAL | | CUST PART NO. | S07 |
| | | | | SECTION NO. | X85576 |

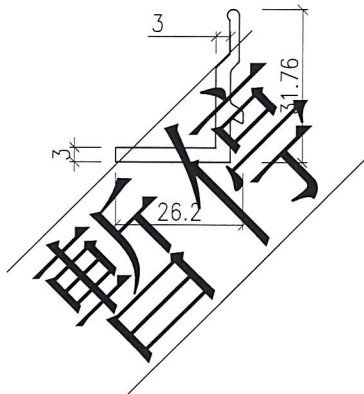

SCALE 1:1

| | | | | | | | | | |
|--------------------|-------------------------|-----------------------|-----------------|----------------|---|----------|---------|---------|-----|
| SIGNATURE GRADEING | HIGH SIGNATURE GRADEING | C.C.DIA(MM) | | | | | | | |
| AREA (SQ MM) | 156.1 | UNSPECIFIED THICKNESS | - | PERIMETER (MM) | - | STANDARD | | SCALE | 1:1 |
| MASS (KG/M) | - | UNSPECIFIED CORNERS | - | SURFACE AREA | - | ALLOY | 6063 T6 | VERSION | |
| COMPANY ISSUE | | | DRAWN | DATE | APELLATION | - | PAGE OF | | |
| | | | STANDARDIZATION | DATE |  美特鋁質有限公司 MIDI Aluminium Fabricator Ltd. | | | | |
| | | | TO SIGN | DATE | | | | | |
| | | | AUDITING | DATE | | | | | |
| MARKER | MODIFY | FILE NO | SIGNATURE | DATE | | | | | |

32

| | | | |
|----------|-------------------|---------------|--------|
| CUSTOMER | CUSTOMER APPROVAL | CUST PART NO. | S08 |
| | | SECTION NO. | X85577 |

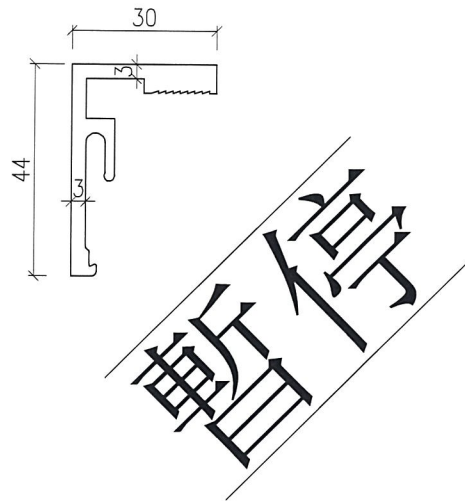

V.F

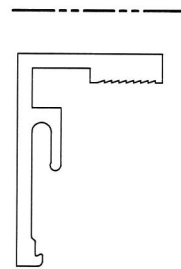

SCALE 1:1

| | | | | | | | | | |
|--------------------|-------------------------|-----------------------|-----------------|----------------|------------|----------|---------|---------|-----|
| SIGNATURE GRADEING | HIGH SIGNATURE GRADEING | C.C.DIA(MM) | | | | | | | |
| AREA (SQ MM) | 302.2 | UNSPECIFIED THICKNESS | - | PERIMETER (MM) | - | STANDARD | | SCALE | 1:1 |
| MASS (KG/M) | - | UNSPECIFIED CORNERS | - | SURFACE AREA | - | ALLOY | 6063 T6 | VERSION | |
| COMPANY ISSUE | | | DRAWN | DATE | APELLATION | - | PAGE OF | | |
| | | | STANDARDIZATION | DATE | | | | | |
| | | | TO SIGN | DATE | | | | | |
| | | | AUDITING | DATE | | | | | |
| MARKER | MODIFY | FILE NO | SIGNATURE | DATE | APPROV | | | | |

美特鋁質有限公司
 MIDI Aluminium Fabricator Ltd.

| | | | | |
|----------|--|-------------------|---------------|--------|
| CUSTOMER | | CUSTOMER APPROVAL | CUST PART NO. | S09 |
| | | | SECTION NO. | X85578 |

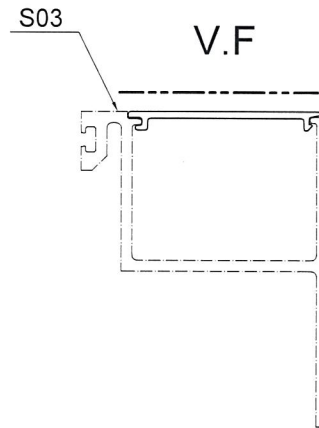
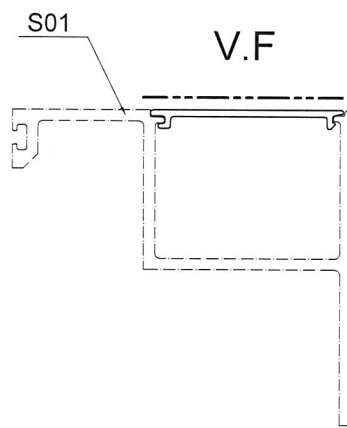
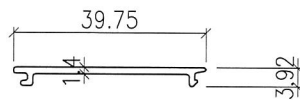
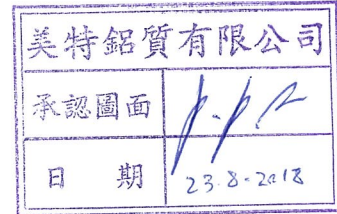

SCALE 1:1

| | | | | | | | | | |
|--------------------|-------------------------|-----------------------|-----------------|----------------|--|----------|---------|---------|-----|
| SIGNATURE GRADEING | HIGH SIGNATURE GRADEING | C.C.DIA(MM) | | | | | | | |
| AREA (SQ MM) | 61.3 | UNSPECIFIED THICKNESS | - | PERIMETER (MM) | - | STANDARD | | SCALE | 1:1 |
| MASS (KG/M) | - | UNSPECIFIED CORNERS | - | SURFACE AREA | - | ALLOY | 6063 T5 | VERSION | |
| COMPANY ISSUE | | | DRAWN | DATE | APPELLATION | | - | PAGE OF | |
| | | | STANDARDIZATION | DATE | 美特鋁質有限公司 MIDI Aluminium Fabricator Ltd. | | | | |
| | | | TO SIGN | DATE | | | | | |
| | | | AUDITING | DATE | | | | | |
| MARKER | MODIFY | FILE NO | SIGNATURE | DATE | | | | | |

| | | | | |
|----------|--|-------------------|---------------|--------|
| CUSTOMER | | CUSTOMER APPROVAL | CUST PART NO. | S10 |
| | | | SECTION NO. | X83579 |

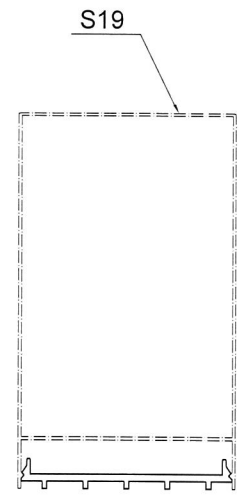
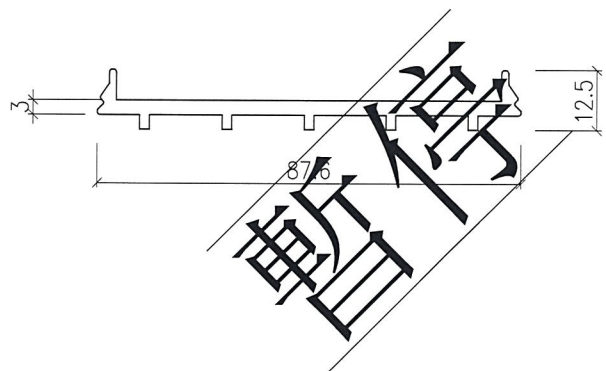

SCALE 1:2

| | | | | | | | | | |
|--------------------|-------------------------|-----------------------|-----------------|----------------|---|----------|---------|---------|-----|
| SIGNATURE GRADEING | HIGH SIGNATURE GRADEING | C.C.DIA(MM) | | | | | | | |
| AREA (SQ MM) | 316.0 | UNSPECIFIED THICKNESS | - | PERIMETER (MM) | - | STANDARD | | SCALE | 1:1 |
| MASS (KG/M) | - | UNSPECIFIED CORNERS | - | SURFACE AREA | - | ALLOY | 6063 T6 | VERSION | |
| COMPANY ISSUE | | | DRAWN | DATE | APPELLATION | | - | PAGE OF | |
| | | | STANDARDIZATION | DATE |  美特鋁質有限公司 MIDI Aluminium Fabricator Ltd. | | | | |
| | | | TO SIGN | DATE | | | | | |
| | | | AUDITING | DATE | | | | | |
| MARKER | MODIFY | FILE NO | SIGNATURE | DATE | | | | | |

| | | | | | |
|----------|--|-------------------|--|---------------|--------|
| CUSTOMER | | CUSTOMER APPROVAL | | CUST PART NO. | S12 |
| | | | | SECTION NO. | X85580 |

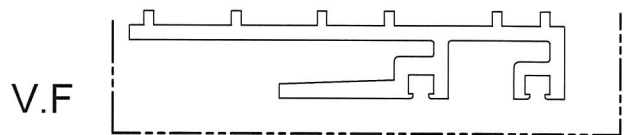
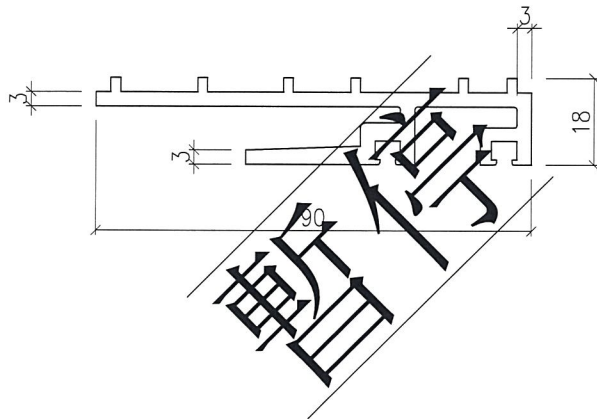

SCALE 1:1

| | | | | | | | | | |
|--------------------|-------------------------|-----------------------|-----------------|----------------|------------|----------|---------|---------|-----|
| SIGNATURE GRADEING | HIGH SIGNATURE GRADEING | C. C. DIA(MM) | | | | | | | |
| AREA (SQ MM) | 541.3 | UNSPECIFIED THICKNESS | - | PERIMETER (MM) | - | STANDARD | | SCALE | 1:1 |
| MASS (KG/M) | - | UNSPECIFIED CORNERS | - | SURFACE AREA | - | ALLOY | 6063 T6 | VERSION | |
| COMPANY ISSUE | | | DRAWN | DATE | APELLATION | - | PAGE OF | | |
| | | | STANDARDIZATION | DATE | | | | | |
| | | | TO SIGN | DATE | | | | | |
| | | | AUDITING | DATE | | | | | |
| MARKER | MODIFY | FILE NO | SIGNATURE | DATE | APPROV | | | | |

美特鋁質有限公司
 MIDI Aluminium Fabricator Ltd.

| | | | | |
|----------|--|-------------------|---------------|--------|
| CUSTOMER | | CUSTOMER APPROVAL | CUST PART NO. | S13 |
| | | | SECTION NO. | X85581 |

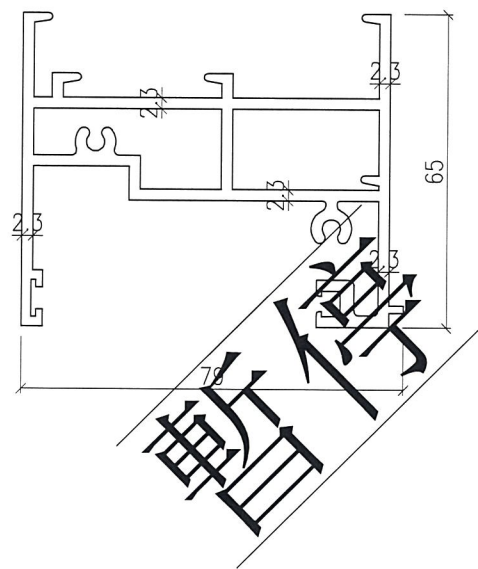

V.F

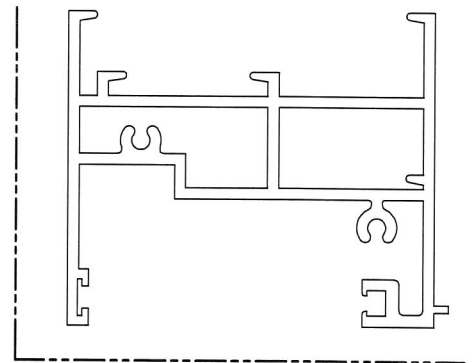

SCALE 1:1

| | | | | | | | | | |
|--------------------|-------------------------|-----------------------|-----------------|----------------|-------------|----------|---------|---------|-----|
| SIGNATURE GRADEING | HIGH SIGNATURE GRADEING | C.C.DIA(MM) | | | | | | | |
| AREA (SQ MM) | 884.0 | UNSPECIFIED THICKNESS | - | PERIMETER (MM) | - | STANDARD | | SCALE | 1:1 |
| MASS (KG/M) | - | UNSPECIFIED CORNERS | - | SURFACE AREA | - | ALLOY | 6063 T6 | VERSION | |
| COMPANY ISSUE | | | DRAWN | DATE | APPELLATION | | - | PAGE OF | |
| | | | STANDARDIZATION | DATE | | | | | |
| | | | TO SIGN | DATE | | | | | |
| | | | AUDITING | DATE | | | | | |
| MARKER | MODIFY | FILE NO | SIGNATURE | DATE | APPROV | DATE | | | |

美特鋁質有限公司
 MIDI Aluminium Fabricator Ltd.

| | | | |
|----------|-------------------|---------------|--------|
| CUSTOMER | CUSTOMER APPROVAL | CUST PART NO. | S15 |
| | | SECTION NO. | X85582 |

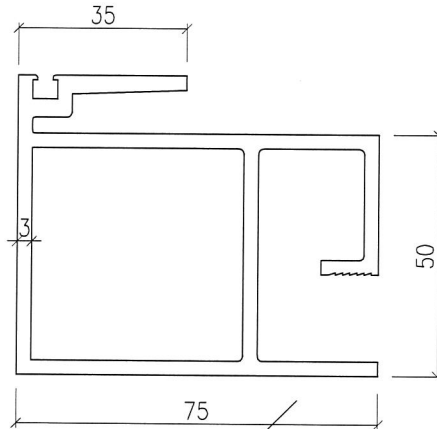

暫停

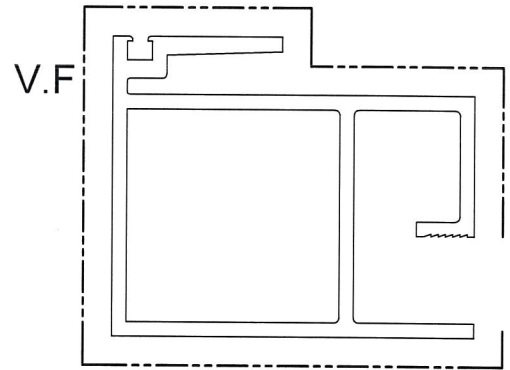

SCALE 1:1

| | | | | | | | | | |
|--------------------|-------------------------|-----------------------|-----------------|----------------|------------|----------|---------|---------|-----|
| SIGNATURE GRADEING | HIGH SIGNATURE GRADEING | C.C.DIA(MM) | | | | | | | |
| AREA (SQ MM) | 1133.3 | UNSPECIFIED THICKNESS | - | PERIMETER (MM) | - | STANDARD | | SCALE | 1:1 |
| MASS (KG/M) | - | UNSPECIFIED CORNERS | - | SURFACE AREA | - | ALLOY | 6063 T6 | VERSION | |
| COMPANY ISSUE | | | DRAWN | DATE | APELLATION | - | PAGE OF | | |
| | | | STANDARDIZATION | DATE | | | | | |
| | | | TO SIGN | DATE | | | | | |
| | | | AUDITING | DATE | | | | | |
| MARKER | MODIFY | FILE NO | SIGNATURE | DATE | APPROV | | | | |



美特鋁質有限公司
 MIDI Aluminium Fabricator Ltd.

38

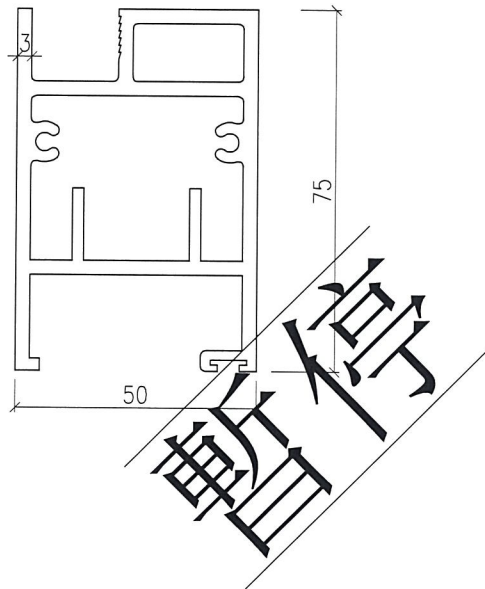
| | | | | | |
|----------|--|-------------------|--|---------------|--------|
| CUSTOMER | | CUSTOMER APPROVAL | | CUST PART NO. | S16 |
| | | | | SECTION NO. | X25583 |

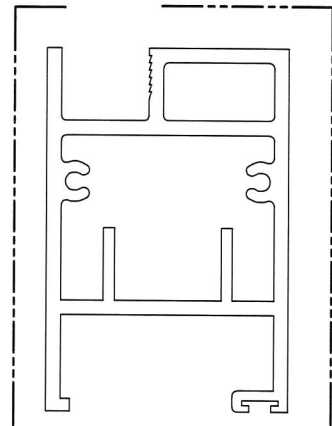

V.F



SCALE 1:1

| | | | | | | | | | |
|--------------------|-------------------------|-----------------------|-------------------|----------------|------------|----------|---------|---------|-----|
| SIGNATURE GRADEING | HIGH SIGNATURE GRADEING | C.C.DIA(MM) | | | | | | | |
| AREA (SQ MM) | 985.4 | UNSPECIFIED THICKNESS | - | PERIMETER (MM) | - | STANDARD | | SCALE | 1:1 |
| MASS (KG/M) | - | UNSPECIFIED CORNERS | - | SURFACE AREA | - | ALLOY | 6063 T6 | VERSION | |
| COMPANY ISSUE | | | DRAWA | DATE | APELLATION | - | PAGE OF | | |
| | | | STANDA- RDIZATION | DATE | | | | | |
| | | | TO SIGN | DATE | | | | | |
| | | | AUDITING | DATE | | | | | |
| MARKER | MODIFY | FILE NO | SIGNATURE | DATE | APPROV | | | | |

美特鋁質有限公司
 MIDI Aluminium Fabricator Ltd.

| | | | | | |
|----------|--|-------------------|--|---------------|--------|
| CUSTOMER | | CUSTOMER APPROVAL | | CUST PART NO. | S17 |
| | | | | SECTION NO. | X25584 |

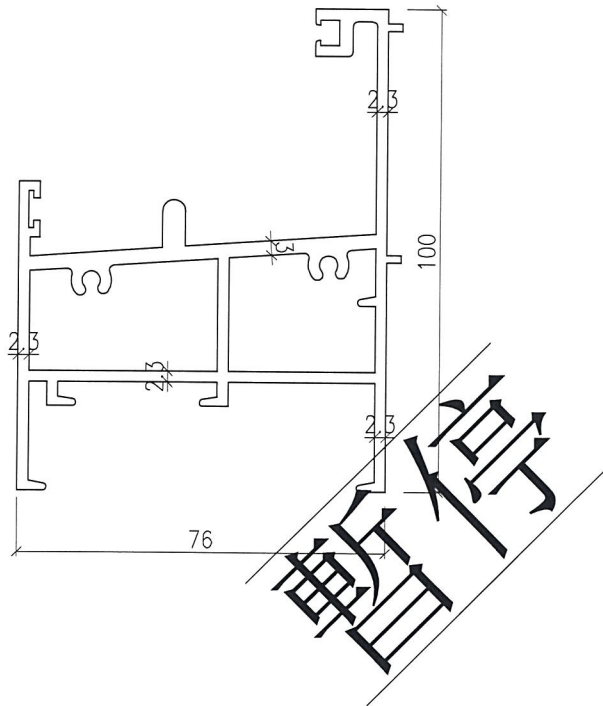

V.F

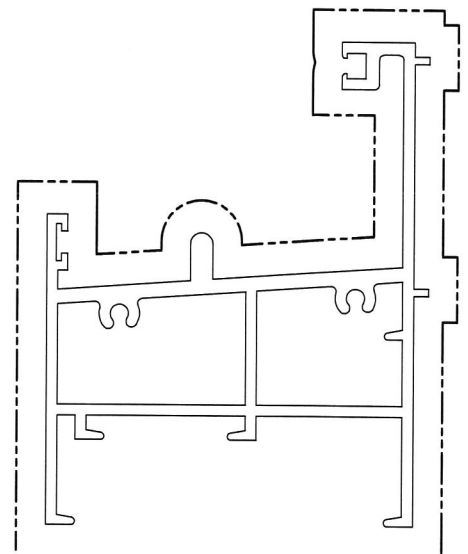

SCALE 1:1

| | | | | | | | | | |
|--------------------|-------------------------|-----------------------|------------------|----------------|-------------|----------|---------|---------|-----|
| SIGNATURE GRADEING | HIGH SIGNATURE GRADEING | C.C.DIA(MM) | | | | | | | |
| AREA (SQ MM) | 1051.6 | UNSPECIFIED THICKNESS | - | PERIMETER (MM) | - | STANDARD | | SCALE | 1:1 |
| MASS (KG/M) | - | UNSPECIFIED CORNERS | - | SURFACE AREA | - | ALLOY | 6063 T5 | VERSION | |
| COMPANY ISSUE | | | DRAWA | DATE | APPELLATION | | - | PAGE OF | |
| | | | STANDA-RDIZATION | DATE | | | | | |
| | | | TO SIGN | DATE | | | | | |
| | | | AUDITING | DATE | | | | | |
| MARKER | MODIFY | FILE NO | SIGNATURE | DATE | APPROV | | | | |



美特鋁質有限公司
 MIDI Aluminium Fabricator Ltd.

40

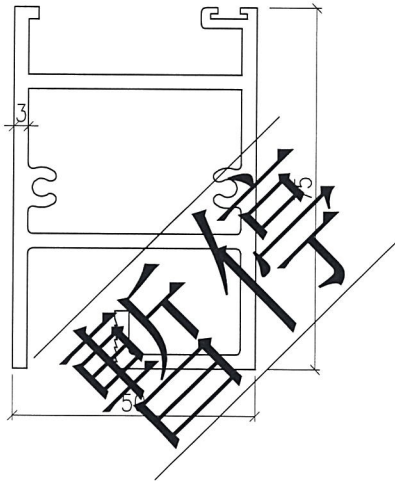
| | | | | | |
|----------|--|-------------------|--|---------------|--------|
| CUSTOMER | | CUSTOMER APPROVAL | | CUST PART NO. | S18 |
| | | | | SECTION NO. | X85585 |

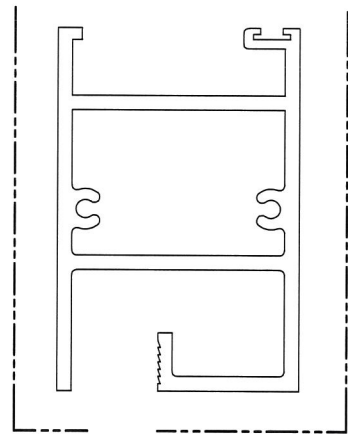

V.F



SCALE 1:1

| | | | | | | | | | |
|--------------------|-------------------------|-----------------------|------------------|----------------|------------|----------|---------|---------|-----|
| SIGNATURE GRADEING | HIGH SIGNATURE GRADEING | C.C.DIA(MM) | | | | | | | |
| AREA (SQ MM) | 907.0 | UNSPECIFIED THICKNESS | - | PERIMETER (MM) | - | STANDARD | | SCALE | 1:1 |
| MASS (KG/M) | - | UNSPECIFIED CORNERS | - | SURFACE AREA | - | ALLOY | 6063 T6 | VERSION | |
| COMPANY ISSUE | | | DRAWA | DATE | APELLATION | - | PAGE OF | | |
| | | | STANDA-RDIZATION | DATE | | | | | |
| | | | TO SIGN | DATE | | | | | |
| | | | AUDITING | DATE | | | | | |
| MARKER | MODIFY | FILE NO | SIGNATURE | DATE | APPROV | | | | |

美特鋁質有限公司
 MIDI Aluminium Fabricator Ltd.

X

| | | | | | |
|----------|--|-------------------|--|---------------|--------|
| CUSTOMER | | CUSTOMER APPROVAL | | CUST PART NO. | S19 |
| | | | | SECTION NO. | X85586 |

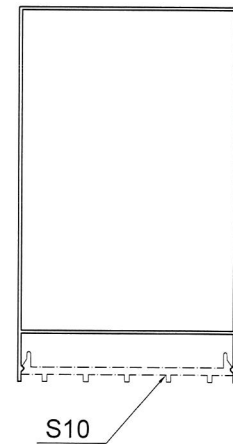
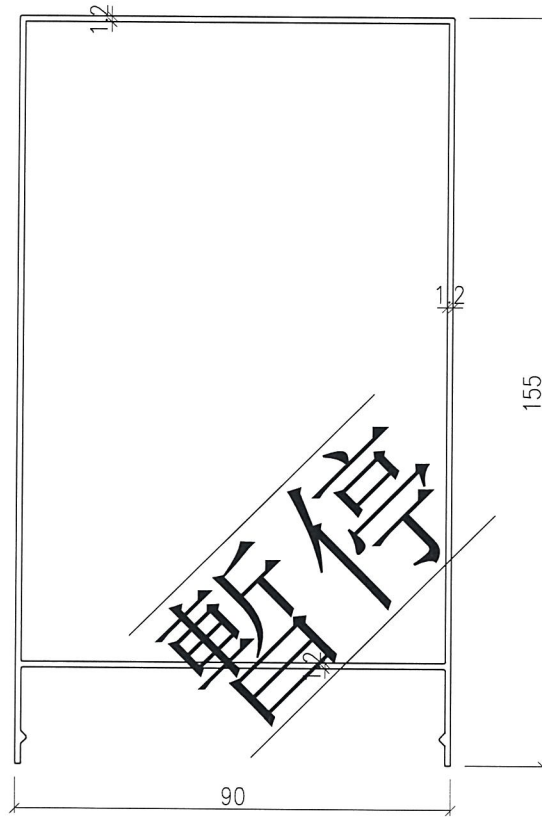

SCALE 1:2

| | | | | | | | | | |
|--------------------|-------------------------|-----------------------|-----------------|----------------|-------------|----------|---------|---------|-----|
| SIGNATURE GRADEING | HIGH SIGNATURE GRADEING | C.C.DIA(MM) | | | | | | | |
| AREA (SQ MM) | 585.9 | UNSPECIFIED THICKNESS | - | PERIMETER (MM) | - | STANDARD | | SCALE | 1:1 |
| MASS (KG/M) | - | UNSPECIFIED CORNERS | - | SURFACE AREA | - | ALLOY | 6063 T6 | VERSION | |
| COMPANY ISSUE | | | DRAWN | DATE | APPELLATION | | - | PAGE OF | |
| | | | STANDARDIZATION | DATE | | | | | |
| | | | TO SIGN | DATE | | | | | |
| | | | AUDITING | DATE | | | | | |
| MARKER | MODIFY | FILE NO | SIGNATURE | DATE | APPROV | DATE | | | |



美特鋁質有限公司
 MIDI Aluminium Fabricator Ltd.

42

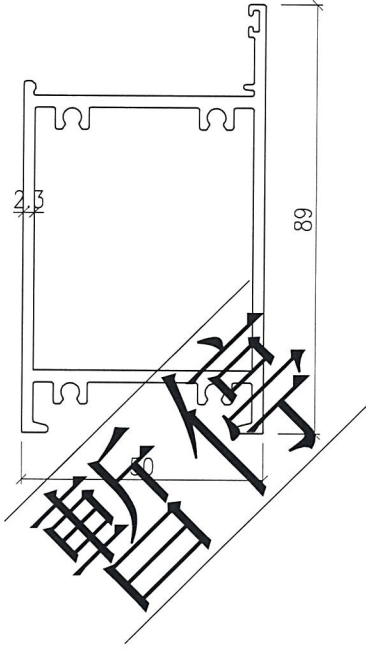
| | | | |
|----------|-------------------|---------------|--------|
| CUSTOMER | CUSTOMER APPROVAL | CUST PART NO. | F01 |
| | | SECTION NO. | X85587 |

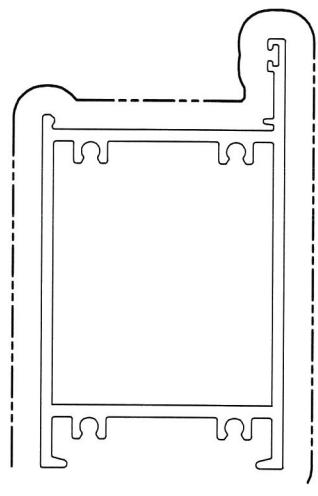

V.F



SCALE 1:1

| | | | | | | | | | |
|--------------------|-------------------------|-----------------------|------------------|----------------|--|----------|---------|---------|-----|
| SIGNATURE GRADEING | HIGH SIGNATURE GRADEING | C.C.DIA(MM) | | | | | | | |
| AREA (SQ MM) | 683.0 | UNSPECIFIED THICKNESS | - | PERIMETER (MM) | - | STANDARD | | SCALE | 1:1 |
| MASS (KG/M) | - | UNSPECIFIED CORNERS | - | SURFACE AREA | - | ALLOY | 6063 T6 | VERSION | |
| COMPANY ISSUE | | | DRAWA | DATE | APELLATION | - | PAGE OF | | |
| | | | STANDA-RDIZATION | DATE |  美特鋁質有限公司 MIDI Aluminium Fabricator Ltd. | | | | |
| | | | TO SIGN | DATE | | | | | |
| | | | AUDITING | DATE | | | | | |
| MARKER | MODIFY | FILE NO | SIGNATURE | DATE | | | | | |

43

| | | | |
|----------|-------------------|---------------|--------|
| CUSTOMER | CUSTOMER APPROVAL | CUST PART NO. | F02 |
| | | SECTION NO. | X85588 |

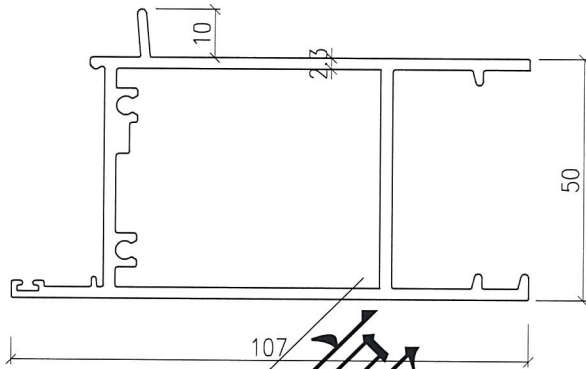

暫停

V.F

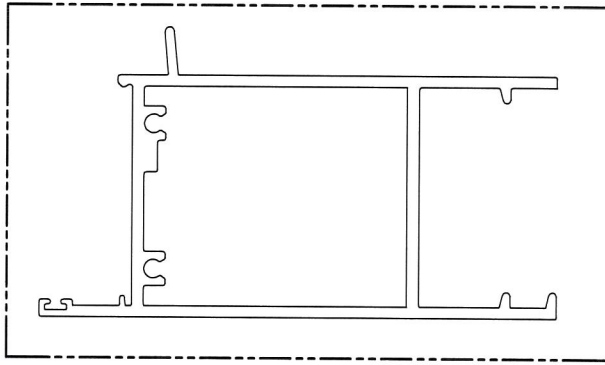

SCALE 1:1

| | | | | | | | | | |
|--------------------|-------------------------|-----------------------|-------------------|----------------|---|----------|---------|---------|-----|
| SIGNATURE GRADEING | HIGH SIGNATURE GRADEING | C.C.DIA(MM) | | | | | | | |
| AREA (SQ MM) | 775.0 | UNSPECIFIED THICKNESS | - | PERIMETER (MM) | - | STANDARD | | SCALE | 1:1 |
| MASS (KG/M) | - | UNSPECIFIED CORNERS | - | SURFACE AREA | - | ALLOY | 6063 T6 | VERSION | |
| COMPANY ISSUE | | | DRAWA | DATE | APPELLATION | - | PAGE OF | | |
| | | | STANDA- RDIZATION | DATE |  美特鋁質有限公司 MIDI Aluminium Fabricator Ltd. | | | | |
| | | | TO SIGN | DATE | | | | | |
| | | | AUDITING | DATE | | | | | |
| MARKER | MODIFY | FILE NO | SIGNATURE | DATE | | | | | |

44

| | | | | |
|----------|--|-------------------|---------------|--------|
| CUSTOMER | | CUSTOMER APPROVAL | CUST PART NO. | F03 |
| | | | SECTION NO. | X85589 |

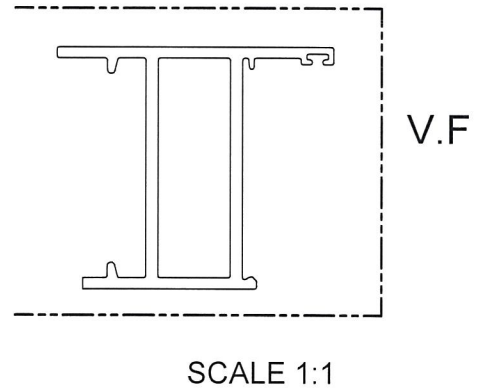
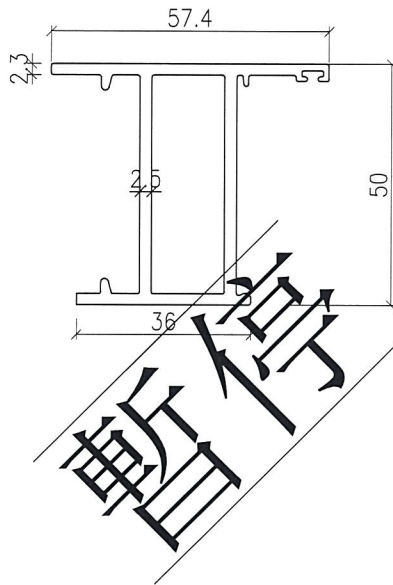

| | | | | | | | | | |
|--------------------|-------------------------|-----------------------|------------------|----------------|------------|----------|---------|---------|-----|
| SIGNATURE GRADEING | HIGH SIGNATURE GRADEING | C.C.DIA(MM) | | | | | | | |
| AREA (SQ MM) | 456.6 | UNSPECIFIED THICKNESS | - | PERIMETER (MM) | - | STANDARD | | SCALE | 1:1 |
| MASS (KG/M) | - | UNSPECIFIED CORNERS | - | SURFACE AREA | - | ALLOY | 6063 T5 | VERSION | |
| COMPANY ISSUE | | | DRAWA | DATE | APELLATION | - | PAGE OF | | |
| | | | STANDA-RDIZATION | DATE | | | | | |
| | | | TO SIGN | DATE | | | | | |
| | | | AUDITING | DATE | | | | | |
| MARKER | MODIFY | FILE NO | SIGNATURE | DATE | APPROV | | | | |



美特鋁質有限公司
 MIDI Aluminium Fabricator Ltd.

Handwritten initials/signature

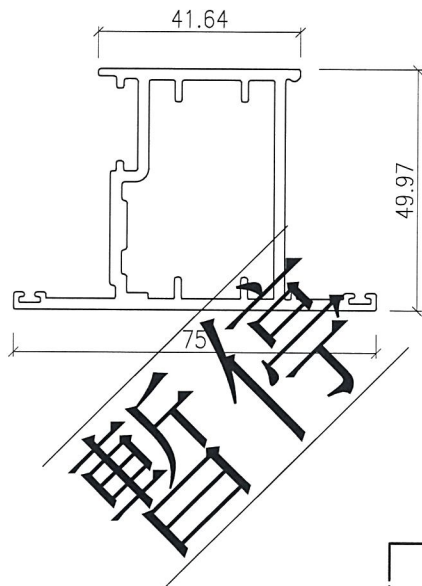
| | | | |
|----------|-------------------|---------------|--------|
| CUSTOMER | CUSTOMER APPROVAL | CUST PART NO. | F04 |
| | | SECTION NO. | X85590 |

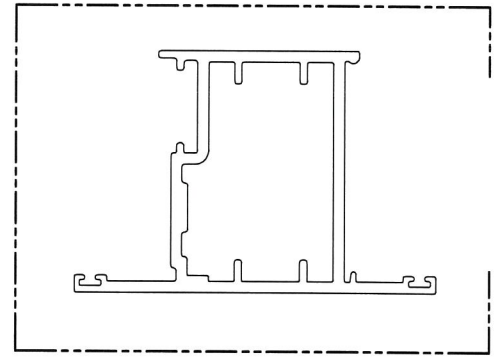

V.F



SCALE 1:1

| | | | | | | | | | |
|--------------------|-------------------------|-----------------------|------------------|----------------|------------|----------|---------|---------|-----|
| SIGNATURE GRADEING | HIGH SIGNATURE GRADEING | C.C.DIA(MM) | | | | | | | |
| AREA (SQ MM) | 540.9 | UNSPECIFIED THICKNESS | - | PERIMETER (MM) | - | STANDARD | | SCALE | 1:1 |
| MASS (KG/M) | - | UNSPECIFIED CORNERS | - | SURFACE AREA | - | ALLOY | 6063 T6 | VERSION | |
| COMPANY ISSUE | | | DRAWA | DATE | APELLATION | - | PAGE OF | | |
| | | | STANDA-RDIZATION | DATE | | | | | |
| | | | TO SIGN | DATE | | | | | |
| | | | AUDITING | DATE | | | | | |
| MARKER | MODIFY | FILE NO | SIGNATURE | DATE | APPROV | | | | |



美特鋁質有限公司
 MIDI Aluminium Fabricator Ltd.

46

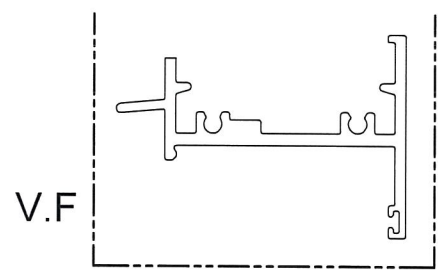
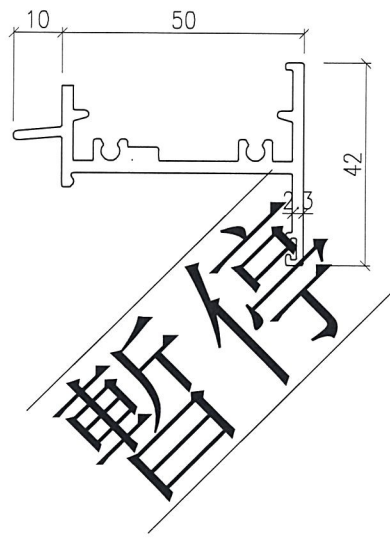
| | | | |
|----------|-------------------|---------------|--------|
| CUSTOMER | CUSTOMER APPROVAL | CUST PART NO. | F05 |
| | | SECTION NO. | X85591 |



SCALE 1:1

| | | | | | | | | | |
|--------------------|-------------------------|-----------------------|-------------------|----------------|---|----------|---------|---------|-----|
| SIGNATURE GRADEING | HIGH SIGNATURE GRADEING | C.C.DIA(MM) | | | | | | | |
| AREA (SQ MM) | 345.1 | UNSPECIFIED THICKNESS | - | PERIMETER (MM) | - | STANDARD | | SCALE | 1:1 |
| MASS (KG/M) | - | UNSPECIFIED CORNERS | - | SURFACE AREA | - | ALLOY | 6063 T6 | VERSION | |
| COMPANY ISSUE | | | DRAWA | DATE | APELATION | | - | PAGE OF | |
| | | | STANDA- RDIZATION | DATE |  美特鋁質有限公司 MIDI Aluminium Fabricator Ltd. | | | | |
| | | | TO SIGN | DATE | | | | | |
| | | | AUDITING | DATE | | | | | |
| MARKER | MODIFY | FILE NO | SIGNATURE | DATE | | | | | |

67

| | | | | | |
|----------|--|-------------------|--|---------------|--------|
| CUSTOMER | | CUSTOMER APPROVAL | | CUST PART NO. | AB01 |
| | | | | SECTION NO. | X85592 |

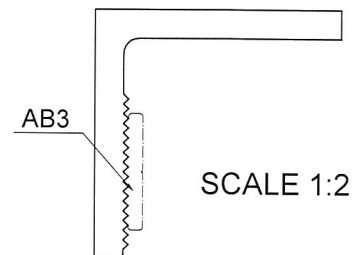
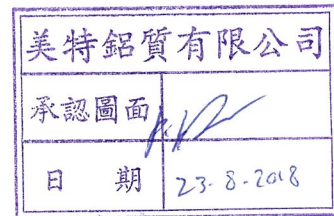
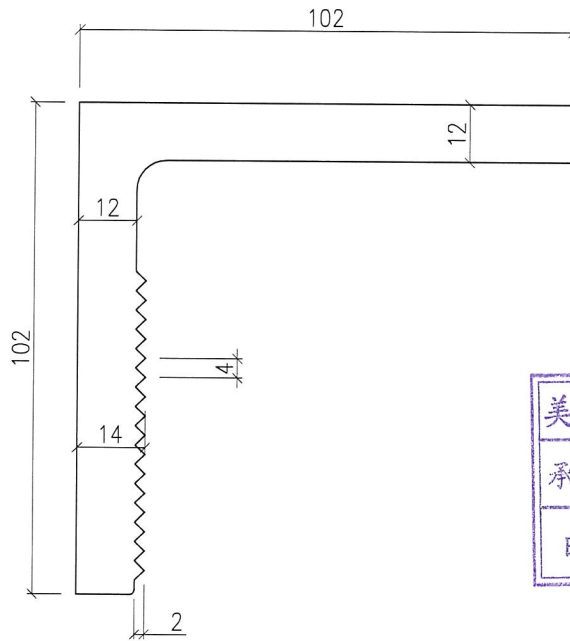

| | | | | | | | | | |
|--------------------|-------------------------|-----------------------|-----------------|----------------|---|----------|---------|---------|-----|
| SIGNATURE GRADEING | HIGH SIGNATURE GRADEING | C.C.DIA(MM) | | | | | | | |
| AREA (SQ MM) | 2376 | UNSPECIFIED THICKNESS | - | PERIMETER (MM) | - | STANDARD | | SCALE | 1:1 |
| MASS (KG/M) | - | UNSPECIFIED CORNERS | - | SURFACE AREA | - | ALLOY | 6061 T6 | VERSION | |
| COMPANY ISSUE | | | DRAWN | DATE | APPELLATION | - | PAGE OF | | |
| | | | STANDARDIZATION | DATE | 美特鋁質有限公司 MIDI Aluminium Fabricator Ltd. | | | | |
| | | | TO SIGN | DATE | | | | | |
| | | | AUDITING | DATE | | | | | |
| MARKER | MODIFY | FILE NO | SIGNATURE | DATE | | | | | |

Handwritten initials

| | | | |
|----------|-------------------|---------------|--------|
| CUSTOMER | CUSTOMER APPROVAL | CUST PART NO. | AB2 |
| | | SECTION NO. | X85593 |

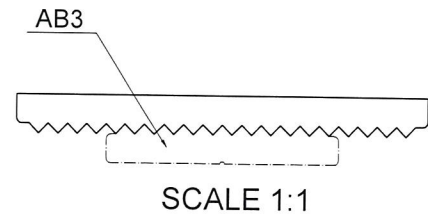
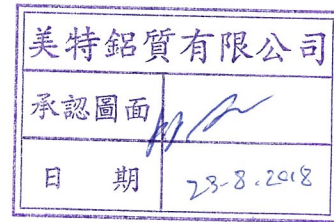
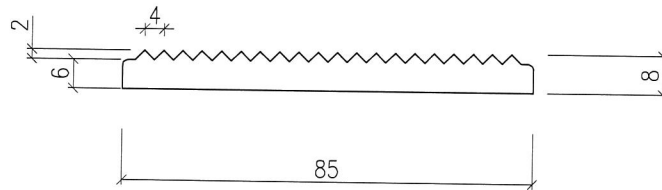

| | | | | | | | | | |
|--------------------|-------------------------|-----------------------|-------------------|----------------|------------|----------|---------|---------|-----|
| SIGNATURE GRADEING | HIGH SIGNATURE GRADEING | C.C.DIA(MM) | | | | | | | |
| AREA (SQ MM) | 589.6 | UNSPECIFIED THICKNESS | - | PERIMETER (MM) | - | STANDARD | | SCALE | 1:1 |
| MASS (KG/M) | - | UNSPECIFIED CORNERS | - | SURFACE AREA | - | ALLOY | 6061 T6 | VERSION | |
| COMPANY ISSUE | | | DRAWA | DATE | APELLATION | - | PAGE OF | | |
| | | | STANDA- RDIZATION | DATE | | | | | |
| | | | TO SIGN | DATE | | | | | |
| | | | AUDITING | DATE | | | | | |
| MARKER | MODIFY | FILE NO | SIGNATURE | DATE | APPROV | | | | |

美特鋁質有限公司
MIDI Aluminium Fabricator Ltd.

69

| | | | | | |
|----------|--|-------------------|--|---------------|-----------------------------|
| CUSTOMER | | CUSTOMER APPROVAL | | CUST PART NO. | AB4 |
| | | | | SECTION NO. | X 85594 85595 |

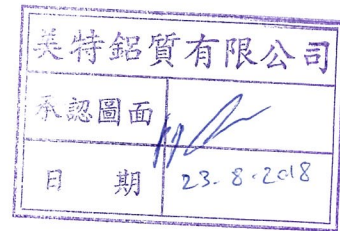
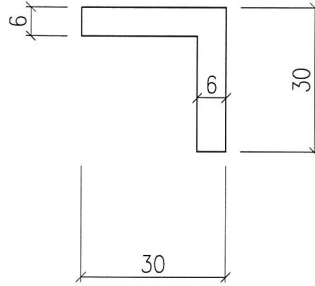

| | | | | | | | | | |
|--------------------|-------------------------|-----------------------|-----------------|----------------|------------|----------|---------|---------|-----|
| SIGNATURE GRADEING | HIGH SIGNATURE GRADEING | C.C.DIA(MM) | | | | | | | |
| AREA (SQ MM) | 324.0 | UNSPECIFIED THICKNESS | - | PERIMETER (MM) | - | STANDARD | | SCALE | 1:1 |
| MASS (KG/M) | - | UNSPECIFIED CORNERS | - | SURFACE AREA | - | ALLOY | 6061 T6 | VERSION | |
| COMPANY ISSUE | | | DRAWN | DATE | APELLATION | - | PAGE OF | | |
| | | | STANDARDIZATION | DATE | | | | | |
| | | | TO SIGN | DATE | | | | | |
| | | | AUDITING | DATE | | | | | |
| MARKER | MODIFY | FILE NO | SIGNATURE | DATE | APPROV | | | | |

美特鋁質有限公司
MIDI Aluminium Fabricator Ltd.

| | | | | | |
|----------|--|-------------------|--|---------------|-----------------------------|
| CUSTOMER | | CUSTOMER APPROVAL | | CUST PART NO. | AB5 |
| | | | | SECTION NO. | X85595 X85596 |

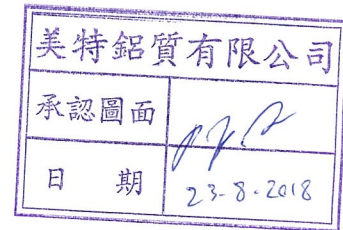
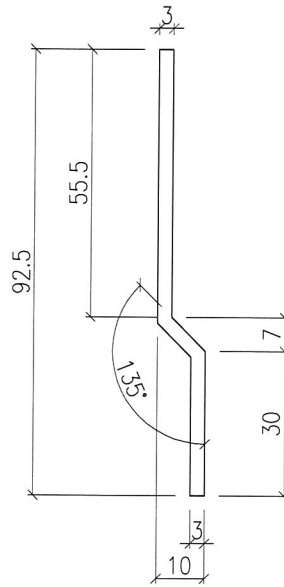

| | | | | | | | | | |
|--------------------|-------------------------|-----------------------|-------------------|----------------|------------|----------|---------|---------|-----|
| SIGNATURE GRADEING | HIGH SIGNATURE GRADEING | C.C.DIA(MM) | | | | | | | |
| AREA (SQ MM) | 286 | UNSPECIFIED THICKNESS | - | PERIMETER (MM) | - | STANDARD | | SCALE | 1:1 |
| MASS (KG/M) | - | UNSPECIFIED CORNERS | - | SURFACE AREA | - | ALLOY | 6063 T5 | VERSION | |
| COMPANY ISSUE | | | DRAWA | DATE | APELLATION | - | PAGE OF | | |
| | | | STANDA- RDIZATION | DATE | | | | | |
| | | | TO SIGN | DATE | | | | | |
| | | | AUDITING | DATE | | | | | |
| MARKER | MODIFY | FILE NO | SIGNATURE | DATE | APPROV | | | | |

美特鋁質有限公司
 MIDI Aluminium Fabricator Ltd.

51