

工程指示 / 要求簡箋(E.I.)

工程指示編號：EI / 9660 / 18

修改版次：J

工程編號：J - 837

工程名稱：觀塘裕民坊

工程項目：幕牆 鋁料模圖繪畫 (11 個)

收件人：Maggie

發件人：Eric Liu

日期：31/10/2018

□要求提供 / □確認 事項：

- | | | |
|------------------------------------|-------------------------------------|-------------------------------|
| <input type="checkbox"/> 初步鋁料 B.M. | <input type="checkbox"/> 加工拆圖，然後生產 | <input type="checkbox"/> 尺寸表 |
| <input type="checkbox"/> 正式鋁料 B.M. | <input type="checkbox"/> 技術上資料 / 指示 | <input type="checkbox"/> 報價 |
| <input type="checkbox"/> 配件 B.M. | <input type="checkbox"/> 樣辦或貨品說明書 | <input type="checkbox"/> 分判合約 |
| <input type="checkbox"/> 其他：_____ | | |

內容：

請留意 J 版: 1) 取消 EI9660I 版本2) J 版鋁料模圖繪畫 (10 個) SD 門3) 修改 1 個模圖(X85598, 改做 6063-T6) (已於 EI9685D 版簽批開模)謝謝！請在 2018/ 11 / 05 前完成上列要求。

附：11 頁模圖+1 頁

以上項目為：

- | | | |
|---------------------------------|--------------------------------------|--------------------------------|
| <input type="checkbox"/> 原合約工程包 | <input type="checkbox"/> 原合約工程加 / 減賬 | <input type="checkbox"/> 新工程報價 |
|---------------------------------|--------------------------------------|--------------------------------|

原因：-

分發東莞各部門：

- | | | | | | |
|--------------------------------------|---|--|------------------------------|--------------------------------|------------------------------|
| <input type="checkbox"/> 生產技術總監 □連附件 | <input checked="" type="checkbox"/> 技術部 <input checked="" type="checkbox"/> 連附件 <u>永林</u> | <input type="checkbox"/> 生產部 | <input type="checkbox"/> 連附件 | <input type="checkbox"/> 機械設計部 | <input type="checkbox"/> 連附件 |
| <input type="checkbox"/> 採購部 | <input type="checkbox"/> 連附件 | <input checked="" type="checkbox"/> 生產統籌部 <input checked="" type="checkbox"/> 連附件 <u>梅</u> | | | |
| <input type="checkbox"/> 質檢部 | <input type="checkbox"/> 連附件 | <input type="checkbox"/> 會計部 | <input type="checkbox"/> 連附件 | <input type="checkbox"/> 報關組 | <input type="checkbox"/> 連附件 |
- 分發其他分判：
 王禮秋 連附件

分發香港各部門：

- | | | | | | | | |
|---|---|-------------------------------|------------------------------|------------------------------|------------------------------|-----------------------------------|------------------------------|
| <input type="checkbox"/> 行政部 | <input type="checkbox"/> 連附件 | <input type="checkbox"/> 會計部 | <input type="checkbox"/> 連附件 | <input type="checkbox"/> 統籌部 | <input type="checkbox"/> 連附件 | <input type="checkbox"/> 工程部地盤科文 | <input type="checkbox"/> 連附件 |
| <input checked="" type="checkbox"/> 採購部 | <input checked="" type="checkbox"/> 連附件 | <input type="checkbox"/> QS 部 | <input type="checkbox"/> 連附件 | <input type="checkbox"/> 維修部 | <input type="checkbox"/> 連附件 | <input type="checkbox"/> 其他 _____ | <input type="checkbox"/> 連附件 |

傳遞編號：

HK 1662/18

發件人簽署：

項目經理簽署：

EI 9660

23 08 2018 28 08 2018 30 08 2018 06 09 2018 11 09 2018 13 09 2018 20 09 2018 27 09 2018 19 10 2018 22 10 2018 29 10 2018

Page	PART	Die No.	0	A	B	C	D	E	F	G	H	I	J
1	M1	X85545	1	1									
2	M2	X85546	1	1									
3	M3	X85547	1										
4	M4	X85548	1			1							
5	M5	X85549	暫停	暫停		1			1				
6	M6	X85550	1										
7	M7	X85551	1			1							
8	T1	X85552	1	1			1						
9	T2	X85553	1										
10	T3	X85554	1										
11	T3A	X85555	1										
12	A01	X85556	1										
13	A02	X85557	1					1					
14	A03	X85558	1			1							
15	A04	X85559	1				1						
16	A05	X85560	1										
17	A06	X85561	1				1						
18	A07	X85562	1				1						
19	A08	X85563	1				1						
20	A09	X85564	1				1						
21	A10	X85565	1		1								
22	A11	X85566	1		1								
23	A12	X85567	1		1								
24	A13	X85568	暫停	暫停		1							
25	A14	X85569	1			1							
26	S01	X85570	1								1		取消
27	S02	X85571	暫停	暫停				1			1		1
28	S03	X85572	1									1	1
29	S04	X85573	暫停	暫停									取消
30	S05	X85574	暫停	暫停						1			
31	S06	X85575	暫停	暫停									取消
32	S07	X85576	暫停	暫停						1			
33	S08	X85577	暫停	暫停						1			
34	S09	X85578	1				1						
35	S10	X85579	暫停	暫停						1			
36	S12	X85580	暫停	暫停						1			1
37	S13	X85581	暫停	暫停							1		1
38	S15	X85582	暫停	暫停							1		1
39	S16	X85583	暫停	暫停							1		1
40	S17	X85584	暫停	暫停							1		1
41	S18	X85585	暫停	暫停							1		1
42	S19	X85586	暫停	暫停						1			
43	F01	X85587	暫停	暫停									
44	F02	X85588	暫停	暫停									
45	F03	X85589	暫停	暫停									
46	F04	X85590	暫停	暫停									
47	F05	X85591	暫停	暫停									
48	AB01	X85592	1	1					1				
49	AB2	X85593	1							1			
50	AB4	X85594	1										
51	AB5	X85595	1	取消									
52	A15	X85596				1							
53	A16	X85597				1							
54	A17	X85598					1						1
55	A18	X85599						1					
56	AB6	X85600							1				
57	S20	X85603							1		1		
58	S21	X85608							1			1	1
59	S22	X85604							1		1		1
60	T1A	X85605											取消
			30	4	3	8	8	3	3	1	9	8	11

CUSTOMER	CUSTOMER APPROVAL	CUST PART NO.	A17
		SECTION NO.	X85598

LH0090913

美特鋁質有限公司	
承認圖面	
日期	2018-1-31

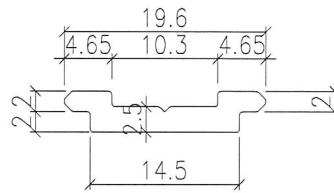

SCALE 2:1

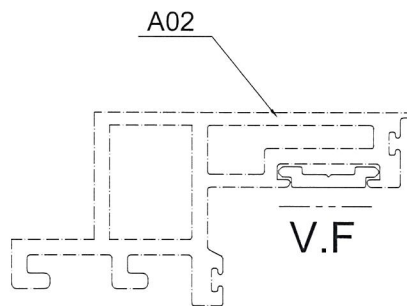

SCALE 1:1

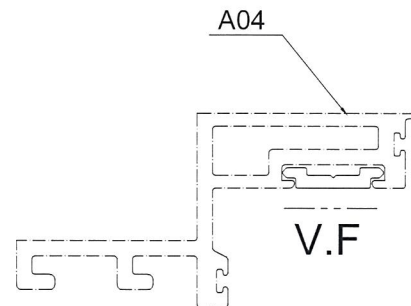

SCALE 1:1

SIGNATURE GRADEING	HIGH SIGNATURE GRADEING	C.C.DIA(MM)							
AREA (SQ MM)	54.7	UNSPECIFIED THICKNESS	-	PERIMETER (MM)	-	STANDARD		SCALE	1:1
MASS (KG/M)	-	UNSPECIFIED CORNERS	-	SURFACE AREA	-	ALLOY	6063 T6	VERSION	
COMPANY ISSUE			DRAWN	DATE		APELLATION	-	PAGE OF	
			STANDARDIZATION	DATE		美特鋁質有限公司 MIDI Aluminium Fabricator Ltd			
			TO SIGN	DATE					
			AUDITING	DATE					
MARKER	MODIFY	FILE NO	SIGNATURE	DATE	APPROV				

CUSTOMER	CUSTOMER APPROVAL	CUST PART NO.	S02
		SECTION NO.	X85571

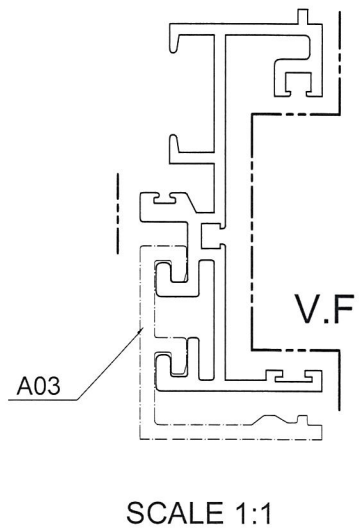
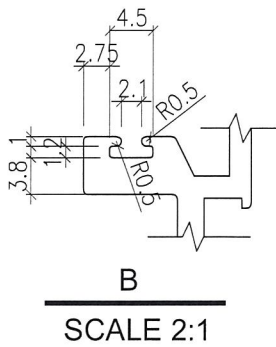
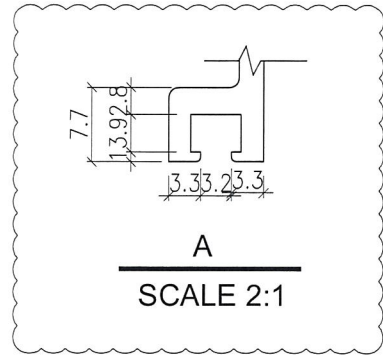
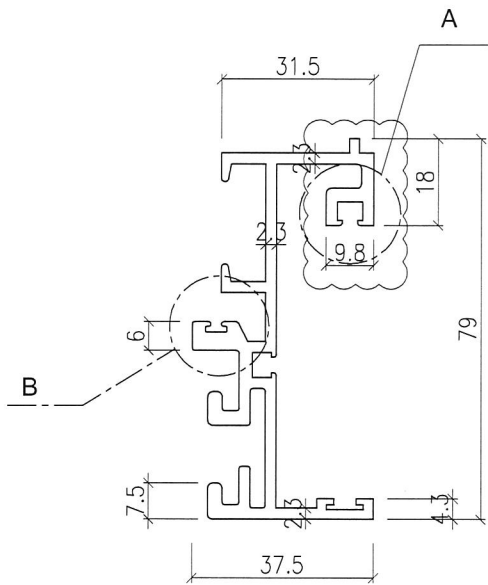

SIGNATURE GRADEING	HIGH SIGNATURE GRADEING	C.C.DIA(MM)							
AREA (SQ MM)	533.75	UNSPECIFIED THICKNESS	-	PERIMETER (MM)	-	STANDARD		SCALE	1:1
MASS (KG/M)	-	UNSPECIFIED CORNERS	-	SURFACE AREA	-	ALLOY	6063 T5	VERSION	B
COMPANY ISSUE			DRAWA	DATE	APELLATION	-	PAGE OF		
			STANDA-RDIZATION	DATE	 美特鋁質有限公司 MIDI Aluminium Fabricator Ltd.				
			TO SIGN	DATE					
			AUDITING	DATE					
MARKER	MODIFY	FILE NO	SIGNATURE	DATE					

CUSTOMER	CUSTOMER APPROVAL	CUST PART NO.	S03
		SECTION NO.	Y85572

LH008993 1/6

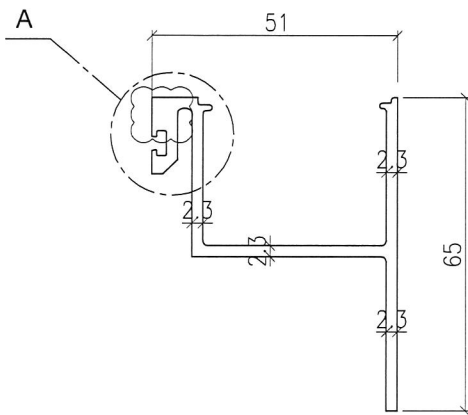

美特鋁質有限公司	
承認圖面	
日期	2018-10-31

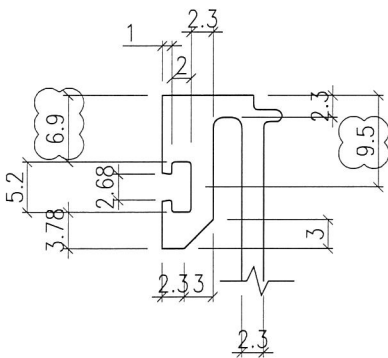

A
SCALE 2:1

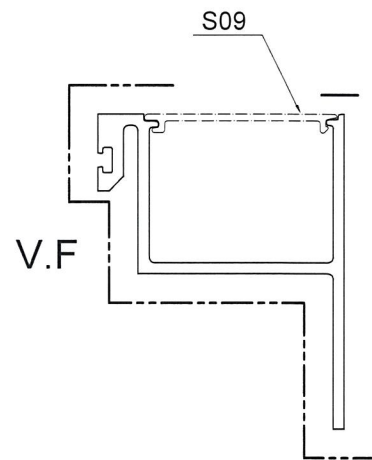

SCALE 1:1

SIGNATURE GRADEING	HIGH SIGNATURE GRADEING	C.C.DIA(MM)							
AREA (SQ MM)	388.6	UNSPECIFIED THICKNESS	-	PERIMETER (MM)	-	STANDARD		SCALE	1:1
MASS (KG/M)	-	UNSPECIFIED CORNERS	-	SURFACE AREA	-	ALLOY	6063 T6	VERSION	B
COMPANY ISSUE			DRAWN	DATE	APELLATION	-	PAGE OF		
			STANDARDIZATION	DATE					
			TO SIGN	DATE					
			AUDITING	DATE					
MARKER	MODIFY	FILE NO	SIGNATURE	DATE	APPROV	DATE			

美特鋁質有限公司
MIDI Aluminium Fabricator Ltd.

CUSTOMER	CUSTOMER APPROVAL	CUST PART NO.	S12
		SECTION NO.	X 855 80

美特鋁質有限公司	
承認圖面	
日期	2018(4-31)

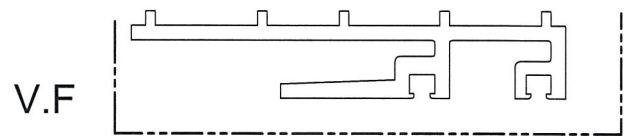
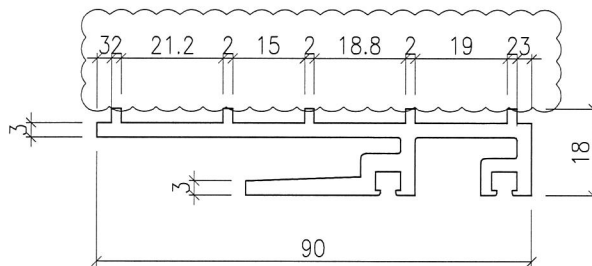

SCALE 1:1

SIGNATURE GRADEING	HIGH SIGNATURE GRADEING	C.C.DIA(MM)							
AREA (SQ MM)	535.34	UNSPECIFIED THICKNESS	-	PERIMETER (MM)	-	STANDARD		SCALE	1:1
MASS (KG/M)	-	UNSPECIFIED CORNERS	-	SURFACE AREA	-	ALLOY	6063 T6	VERSION	A
COMPANY ISSUE			DRAWA	DATE	APELLATION	-	PAGE OF		
			STANDA- RDIZATION	DATE					
			TO SIGN	DATE					
			AUDITING	DATE					
MARKER	MODIFY	FILE NO	SIGNATURE	DATE	APPROV				

 美特鋁質有限公司
MIDI Aluminium Fabricator Ltd.

CUSTOMER	CUSTOMER APPROVAL	CUST PART NO.	S16
		SECTION NO.	x 85583

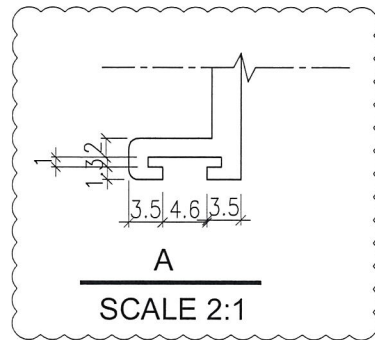
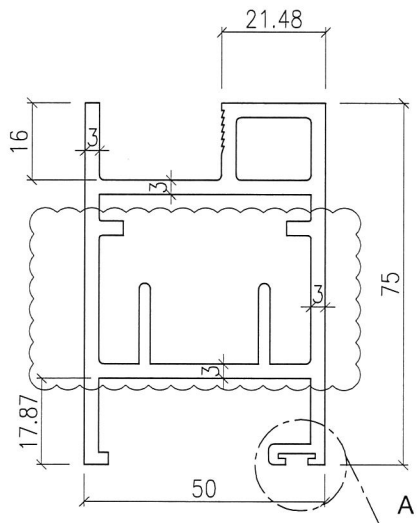
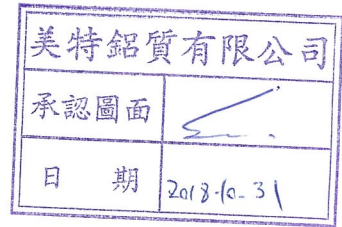

V.F

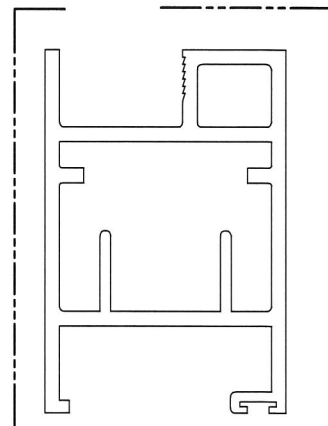

SCALE 1:1

SIGNATURE GRADEING	HIGH SIGNATURE GRADEING	C.C.DIA(MM)							
AREA (SQ MM)	942.16	UNSPECIFIED THICKNESS	-	PERIMETER (MM)	-	STANDARD		SCALE	1:1
MASS (KG/M)	-	UNSPECIFIED CORNERS	-	SURFACE AREA	-	ALLOY	6063 T6	VERSION	B
COMPANY ISSUE			DRAWA	DATE	APELLATION	-	PAGE OF		
			STANDA-	DATE					
			RDIZATION	DATE					
			TO SIGN	DATE					
			AUDITING	DATE					
MARKER	MODIFY	FILE NO	SIGNATURE	DATE	APPROV				

CUSTOMER		CUSTOMER APPROVAL		CUST PART NO.	S18
				SECTION NO.	X85585

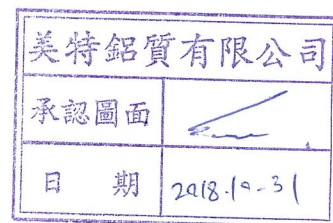
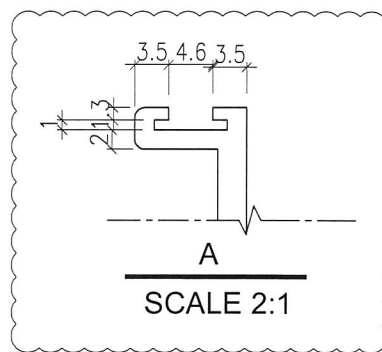
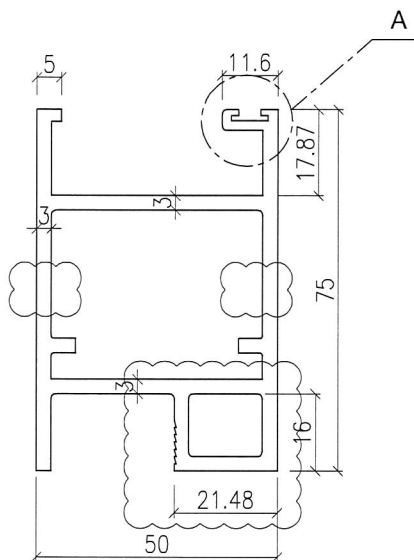

V.F

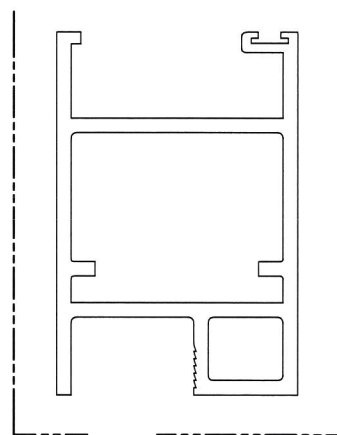

SCALE 1:1

SIGNATURE GRADEING	HIGH SIGNATURE GRADEING	C.C.DIA(MM)							
AREA (SQ MM)	866.09	UNSPECIFIED THICKNESS	-	PERIMETER (MM)	-	STANDARD		SCALE	1:1
MASS (KG/M)	-	UNSPECIFIED CORNERS	-	SURFACE AREA	-	ALLOY	6063 T6	VERSION	B
COMPANY ISSUE			DRAWA	DATE	APELLATION	-	PAGE OF		
			STANDA-	DATE			 美特鋁質有限公司 MIDI Aluminium Fabricator Ltd.		
			RDIZATION	DATE					
			TO SIGN	DATE					
			AUDITING	DATE					
MARKER	MODIFY	FILE NO	SIGNATURE	DATE	APPROV				

CUSTOMER	CUSTOMER APPROVAL	CUST PART NO.	S21
		SECTION NO.	X85608

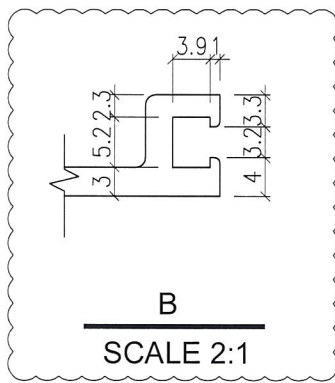
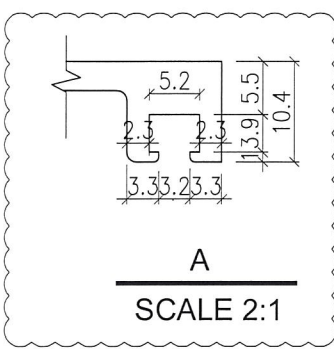
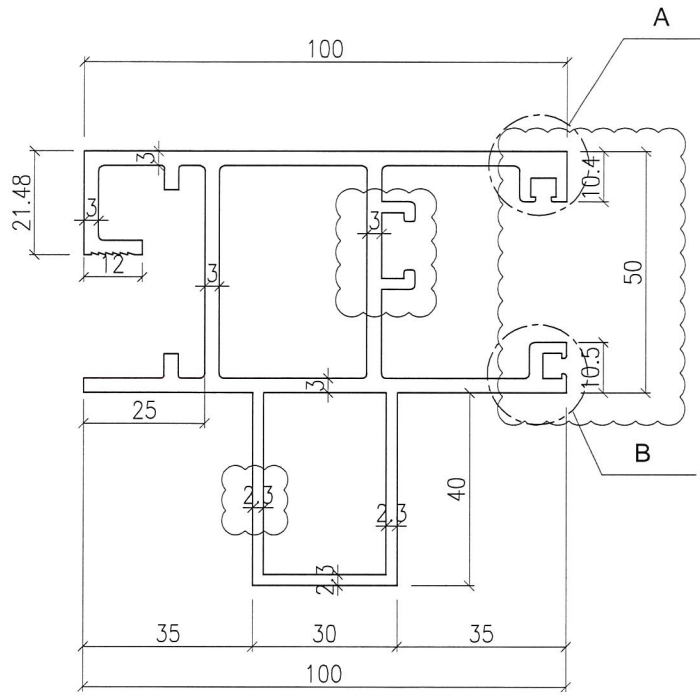

美特鋁質有限公司
承認圖面
日期 2018-10-31

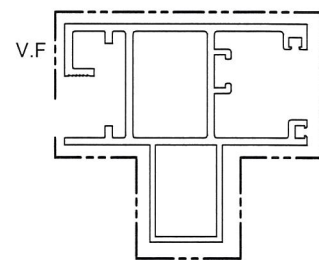

SIGNATURE GRADEING	HIGH SIGNATURE GRADEING	C.C.DIA(MM)							
AREA (SQ MM)	1341.44	UNSPECIFIED THICKNESS	-	PERIMETER (MM)	-	STANDARD		SCALE	1:1
MASS (KG/M)	-	UNSPECIFIED CORNERS	-	SURFACE AREA	-	ALLOY	6063 T6	VERSION	B
COMPANY ISSUE			DRAWA	DATE	APELLATION	-	PAGE OF		
			STANDA-RDIZATION	DATE					
			TO SIGN	DATE					
			AUDITING	DATE					
MARKER	MODIFY	FILE NO	SIGNATURE	DATE	APPROV				

美特鋁質有限公司
MIDI Aluminium Fabricator Ltd.

CUSTOMER	CUSTOMER APPROVAL	CUST PART NO.	S22
		SECTION NO.	X85604

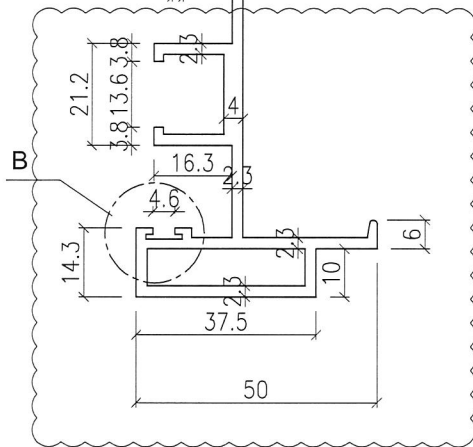
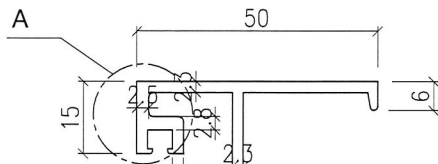
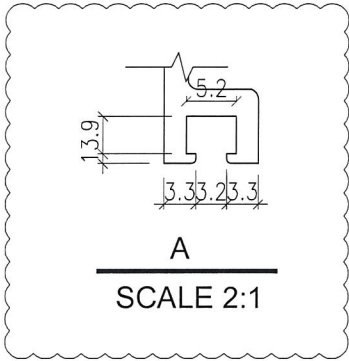

美特鋁質有限公司
承認圖面
日期 2018-10-31

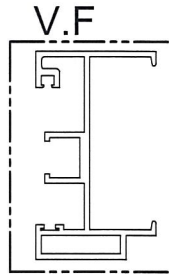
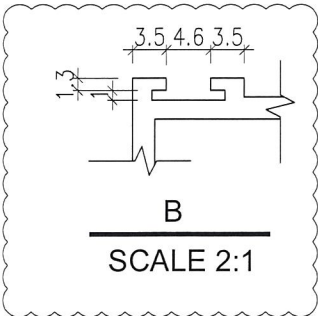

SCALE 1:2

SIGNATURE GRADEING	HIGH SIGNATURE GRADEING	C.C.DIA(MM)							
AREA (SQ MM)	711.53	UNSPECIFIED THICKNESS	-	PERIMETER (MM)	-	STANDARD		SCALE	1:1
MASS (KG/M)	-	UNSPECIFIED CORNERS	-	SURFACE AREA	-	ALLOY	6063 T6	VERSION	A
COMPANY ISSUE			DRAWA	DATE	APELLATION	-	PAGE OF		
			STANDA-	DATE					
			RDIZATION	DATE					
			TO SIGN	DATE					
			AUDITING	DATE					
MARKER	MODIFY	FILE NO	SIGNATURE	DATE	APPROV				

美特鋁質有限公司
MIDI Aluminium Fabricator Ltd.