



工程指示 / 要求簡箋(E.I.)

工程指示編號：EI / 9660 / 18

修改版次：D

工程編號：J - 837

工程名稱：觀塘裕民坊

工程項目：幕牆 鋁料模圖 (7個)

收件人：Maggie

發件人：Eric Liu

日期：11/09/2018

要求提供 / 確認 事項：

- | | | |
|------------------------------------|-------------------------------------|-------------------------------|
| <input type="checkbox"/> 初步鋁料 B.M. | <input type="checkbox"/> 加工拆圖，然後生產 | <input type="checkbox"/> 尺寸表 |
| <input type="checkbox"/> 正式鋁料 B.M. | <input type="checkbox"/> 技術上資料 / 指示 | <input type="checkbox"/> 報價 |
| <input type="checkbox"/> 配件 B.M. | <input type="checkbox"/> 樣辦或貨品說明書 | <input type="checkbox"/> 分判合約 |
| <input type="checkbox"/> 其他：_____ | | |

內容：

D 版修改模圖 6 個，新增模圖 1 個 (修改：X85552, X85559, X85561, X85562, X85563, X85564)

謝謝！

請留意：X85563 及 X85564 在 E.I. 9685B 等批過生產

請在 2018/09/13 前完成上列要求。

附：7頁模圖+1頁

以上項目為：

- 原合約工程包 原合約工程加 / 減賬 新工程報價

原因：-

分發東莞各部門：

- () 生產技術總監 連附件 () 技術部 連附件 ^{永林} () 生產部 連附件 () 機械設計部 連附件
 () 採購部 連附件 () 生產統籌部 連附件 ^梅
 () 質檢部 連附件 () 會計部 連附件 () 報關組 連附件 () 其他 楊榮輝 連附件

分發其他分判：
() 王禮秋 連附件

分發香港各部門：

- () 行政部 連附件 () 會計部 連附件 () 統籌部 連附件 () 工程部地盤科文 連附件
 () 採購部 連附件 () QS 部 連附件 () 維修部 連附件 () 其他 _____ 連附件

傳遞編號：

HK 1445 / 18

發件人簽署：

項目經理簽署：

Page	PART	Die No.	0	A	B	C	D
1	M1	X85545	1	1			
2	M2	X85546	1	1			
3	M3	X85547	1				
4	M4	X85548	1			1	
5	M5	X85549	暫停	暫停		1	
6	M6	X85550	1				
7	M7	X85551	1			1	
8	T1	X85552	1	1			1
9	T2	X85553	1				
10	T3	X85554	1				
11	T3A	X85555	1				
12	A01	X85556	1				
13	A02	X85557	1				
14	A03	X85558	1			1	
15	A04	X85559	1				1
16	A05	X85560	1				
17	A06	X85561	1				1
18	A07	X85562	1				1
19	A08	X85563	1				1
20	A09	X85564	1				1
21	A10	X85565	1		1		
22	A11	X85566	1		1		
23	A12	X85567	1		1		
24	A13	X85568	暫停	暫停		1	
25	A14	X85569	1			1	
26	S01	X85570	1				
27	S02	X85571	暫停	暫停			
28	S03	X85572	1				
29	S04	X85573	暫停	暫停			
30	S05	X85574	暫停	暫停			
31	S06	X85575	暫停	暫停			
32	S07	X85576	暫停	暫停			
33	S08	X85577	暫停	暫停			
34	S09	X85578	1				1
35	S10	X85579	暫停	暫停			
36	S12	X85580	暫停	暫停			
37	S13	X85581	暫停	暫停			
38	S15	X85582	暫停	暫停			
39	S16	X85583	暫停	暫停			
40	S17	X85584	暫停	暫停			
41	S18	X85585	暫停	暫停			
42	S19	X85586	暫停	暫停			
43	F01	X85587	暫停	暫停			
44	F02	X85588	暫停	暫停			
45	F03	X85589	暫停	暫停			
46	F04	X85590	暫停	暫停			
47	F05	X85591	暫停	暫停			
48	AB01	X85592	1	1			
49	AB2	X85593	1				
50	AB4	X85594	1				
51	AB5	X85595	1				
52	A15	X85596				1	
53	A16	X85597				1	
54	A17	X85598					1
			30	4	3	8	8

4.

CUSTOMER	CUSTOMER APPROVAL	CUST PART NO.	A04
		SECTION NO.	

以此為準

x.85559

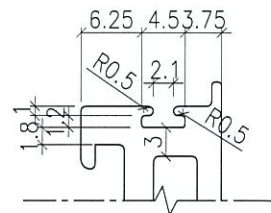

A
SCALE 2:1

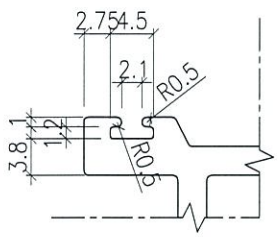
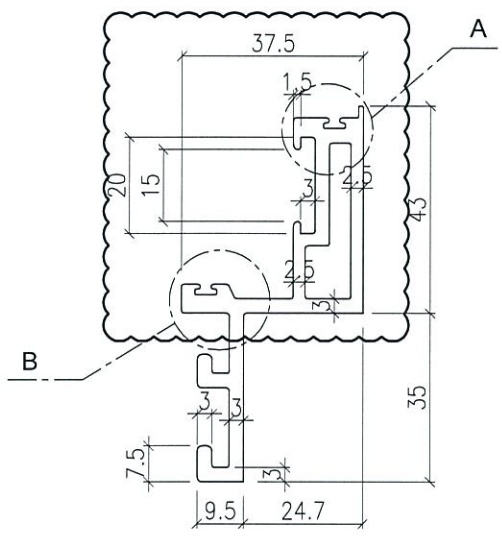

B
SCALE 2:1

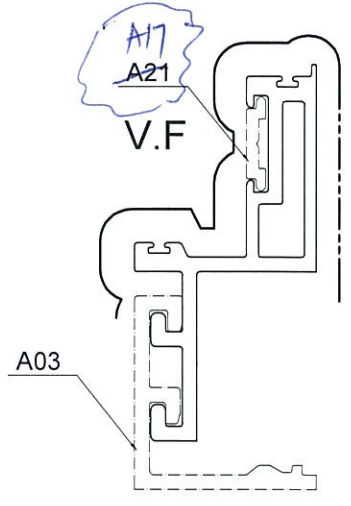

A03
SCALE 1:1

SIGNATURE GRADEING	HIGH SIGNATURE GRADEING	C.C.DIA(MM)							
AREA (SQ MM)	559.67	UNSPECIFIED THICKNESS	-	PERIMETER (MM)	-	STANDARD		SCALE	1:1
MASS (KG/M)	-	UNSPECIFIED CORNERS	-	SURFACE AREA	-	ALLOY	6063 T6	VERSION	B
COMPANY ISSUE			DRAWA	DATE	APELLATION		-	PAGE OF	
			STANDA-	DATE	 美特鋁質有限公司 MIDI Aluminium Fabricator Ltd.				
			RDIZATION	DATE					
			TO SIGN	DATE					
			AUDITING	DATE					
MARKER	MODIFY	FILE NO	SIGNATURE	DATE	APPROV				

CUSTOMER	CUSTOMER APPROVAL	CUST PART NO.	A06
		SECTION NO.	

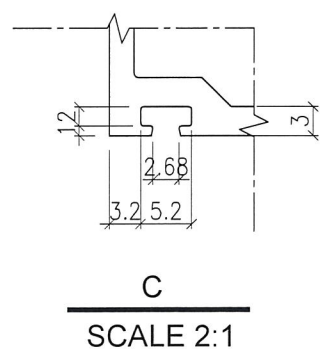
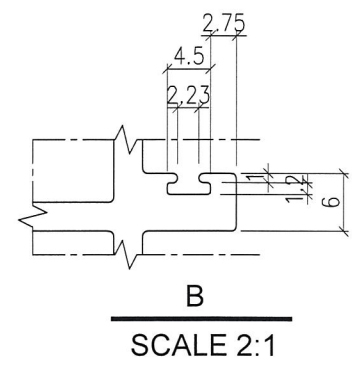
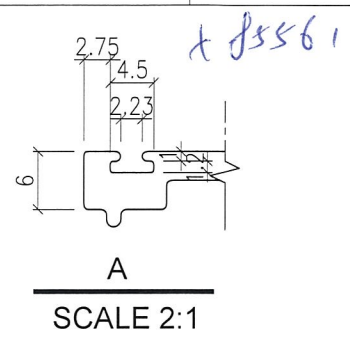
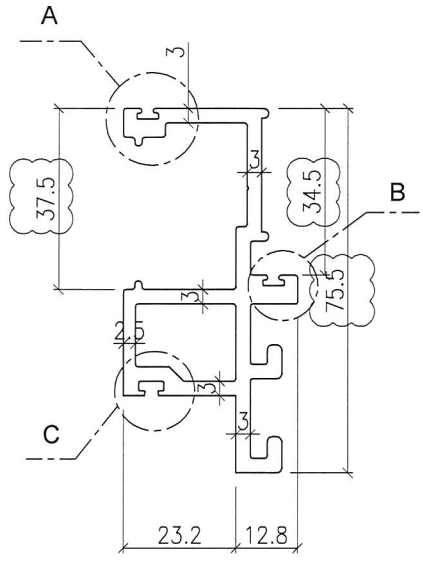

美特鋁質有限公司
承認圖面
日期 2018.9.11

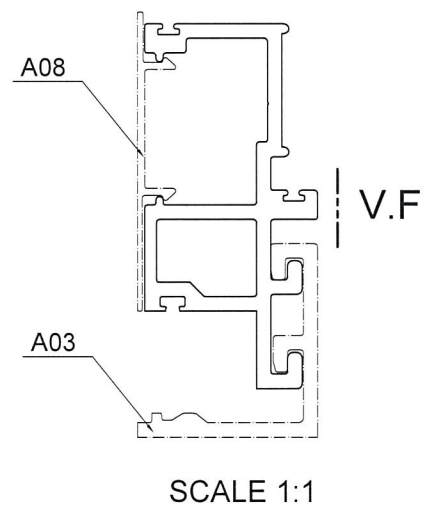

SIGNATURE GRADEING	HIGH SIGNATURE GRADEING	C.C.DIA(MM)							
AREA (SQ MM)	644.33	UNSPECIFIED THICKNESS	-	PERIMETER (MM)	-	STANDARD		SCALE	1:1
MASS (KG/M)	-	UNSPECIFIED CORNERS	-	SURFACE AREA	-	ALLOY	6063 T6	VERSION	A
COMPANY ISSUE			DRAWN	DATE	APPELLATION		-	PAGE OF	
			STANDARDIZATION	DATE					
			TO SIGN	DATE					
			AUDITING	DATE					
MARKER	MODIFY	FILE NO	SIGNATURE	DATE	APPROV				

CUSTOMER	CUSTOMER APPROVAL	CUST PART NO.	A07
		SECTION NO.	

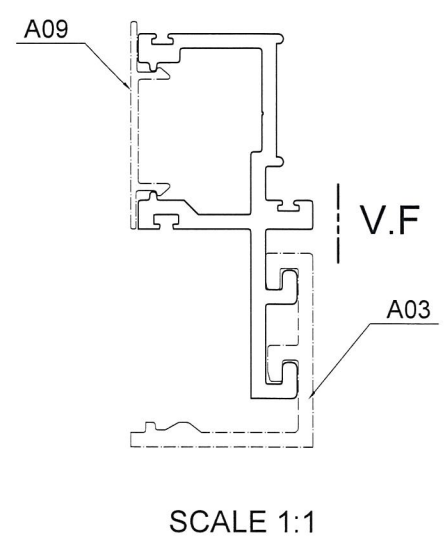
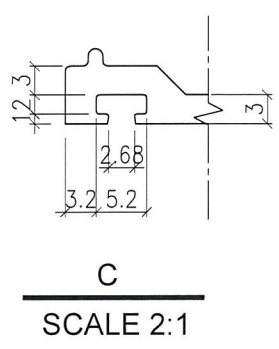
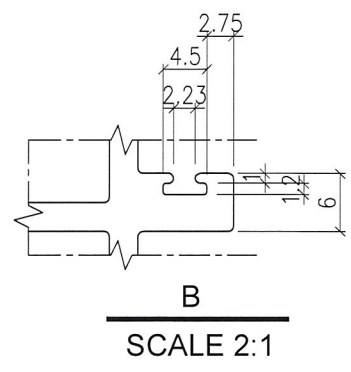
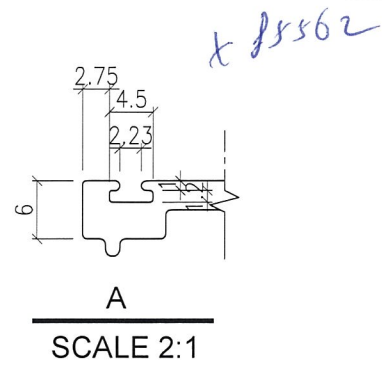
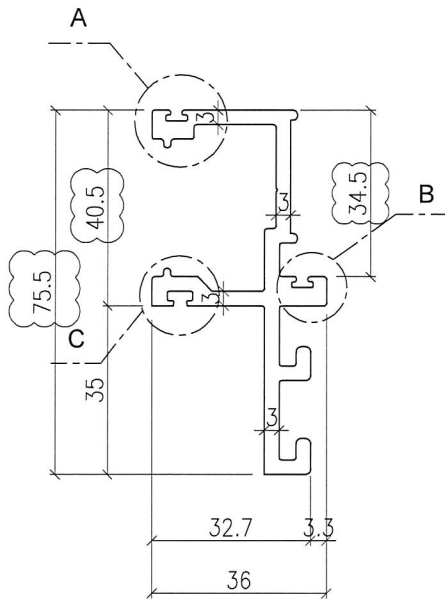

美特鋁質有限公司	
承認圖面	
日期	2018.9.11

SIGNATURE GRADEING	HIGH SIGNATURE GRADEING	C.C.DIA(MM)							
AREA (SQ MM)	542.07	UNSPECIFIED THICKNESS	-	PERIMETER (MM)	-	STANDARD		SCALE	1:1
MASS (KG/M)	-	UNSPECIFIED CORNERS	-	SURFACE AREA	-	ALLOY	6063 T6	VERSION	A
COMPANY ISSUE			DRAWA	DATE	APELATION		-	PAGE OF	
			STANDA-	DATE					
			RDIZATION	DATE					
			TO SIGN	DATE					
			AUDITING	DATE					
MARKER	MODIFY	FILE NO	SIGNATURE	DATE	APPROV				

CUSTOMER	CUSTOMER APPROVAL	CUST PART NO.	A08
		SECTION NO.	

X J5563

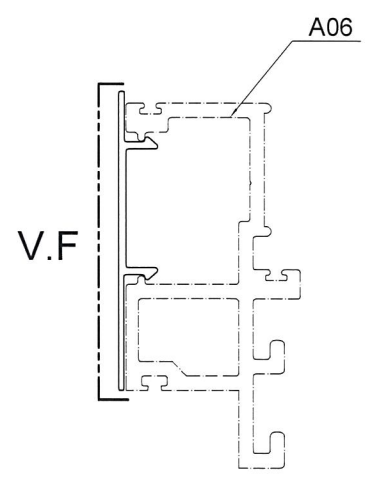
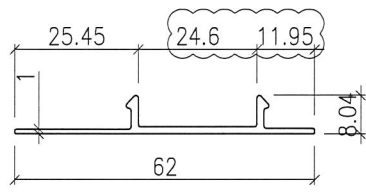

美特鋁質有限公司
承認圖面
日期 2013.9.11

SCALE 1:1

SIGNATURE GRADEING	HIGH SIGNATURE GRADEING	C.C.DIA(MM)							
AREA (SQ MM)	98.98	UNSPECIFIED THICKNESS	-	PERIMETER (MM)	-	STANDARD		SCALE	1:1
MASS (KG/M)	-	UNSPECIFIED CORNERS	-	SURFACE AREA	-	ALLOY	6063 T5	VERSION	A
COMPANY ISSUE			DRAWN	DATE	APPELLATION		-	PAGE OF	
			STANDARDIZATION	DATE	 美特鋁質有限公司 MIDI Aluminium Fabricator Ltd.				
			TO SIGN	DATE					
			AUDITING	DATE					
MARKER	MODIFY	FILE NO	SIGNATURE	DATE					

CUSTOMER		CUSTOMER APPROVAL		CUST PART NO.	A09
				SECTION NO.	

X 85564

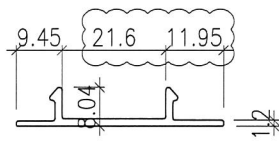

美特鋁質有限公司	
承認圖面	
日期	2018-9-11

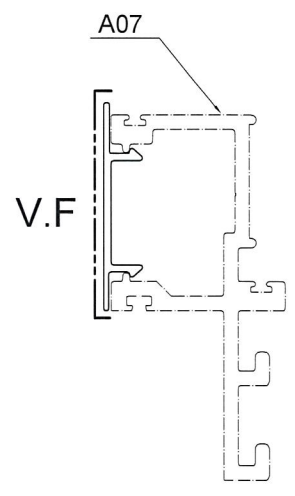

SCALE 1:1

SIGNATURE GRADEING	HIGH SIGNATURE GRADEING	C.C.DIA(MM)							
AREA (SQ MM)	78.48	UNSPECIFIED THICKNESS	-	PERIMETER (MM)	-	STANDARD		SCALE	1:1
MASS (KG/M)	-	UNSPECIFIED CORNERS	-	SURFACE AREA	-	ALLOY	6063 T5	VERSION	A
COMPANY ISSUE			DRAWA	DATE	APELLATION	-	PAGE OF		
			STANDA-RDIZATION	DATE					
			TO SIGN	DATE					
			AUDITING	DATE					
MARKER	MODIFY	FILE NO	SIGNATURE	DATE	APPROV				

美特鋁質有限公司
MIDI Aluminium Fabricator Ltd.

CUSTOMER	CUSTOMER APPROVAL	CUST PART NO.	A17
		SECTION NO.	

x 85598

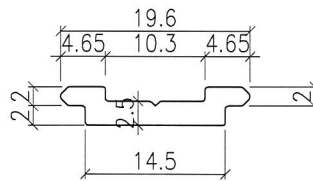

SCALE 2:1

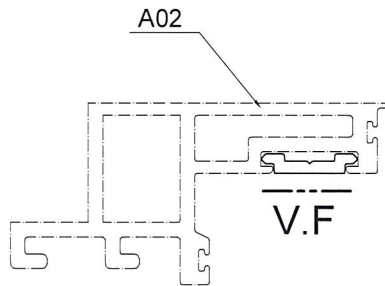
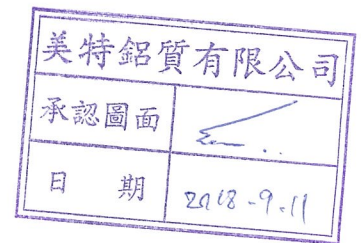

SCALE 1:1

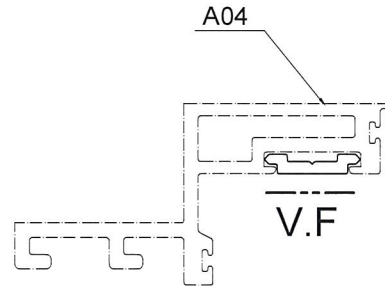

SCALE 1:1

SIGNATURE GRADEING	HIGH SIGNATURE GRADEING	C.C.DIA(MM)							
AREA (SQ MM)	54.7	UNSPECIFIED THICKNESS	-	PERIMETER (MM)	-	STANDARD		SCALE	1:1
MASS (KG/M)	-	UNSPECIFIED CORNERS	-	SURFACE AREA	-	ALLOY	6061 T6	VERSION	
COMPANY ISSUE			DRAWA	DATE	APELLATION	-	PAGE OF		
			STANDA-	DATE	 美特鋁質有限公司 MIDI Aluminium Fabricator Ltd.				
			RDIZATION	DATE					
			TO SIGN	DATE					
			AUDITING	DATE					
MARKER	MODIFY	FILE NO	SIGNATURE	DATE	APPROV	DATE			