



工程指示 / 要求簡箋(E.I.)

工程指示編號：EI / 9660 / 18

修改版次：C

工程編號：J - 837

工程名稱：觀塘裕民坊

工程項目：幕牆 鋁料模圖 (8 個)

收件人：Maggie

發件人：Eric Liu

日期：06/09/2018

要求提供 / 確認 事項：

- | | | |
|------------------------------------|-------------------------------------|-------------------------------|
| <input type="checkbox"/> 初步鋁料 B.M. | <input type="checkbox"/> 加工拆圖，然後生產 | <input type="checkbox"/> 尺寸表 |
| <input type="checkbox"/> 正式鋁料 B.M. | <input type="checkbox"/> 技術上資料 / 指示 | <input type="checkbox"/> 報價 |
| <input type="checkbox"/> 配件 B.M. | <input type="checkbox"/> 樣辦或貨品說明書 | <input type="checkbox"/> 分判合約 |
| <input type="checkbox"/> 其他：_____ | | |

內容：

C 版修改模圖 8 個

謝謝！

請在 2018/ 09 / 11 前完成上列要求。

附：8 頁模圖+1 頁

以上項目為：

- 原合約工程包 原合約工程加 / 減賬 新工程報價

原因：-

分發東莞各部門：

- () 生產技術總監 連附件 () 技術部 連附件 ^{永林} () 生產部 連附件 () 機械設計部 連附件
 () 採購部 連附件 () 生產統籌部 連附件 ^梅
 () 質檢部 連附件 () 會計部 連附件 () 報關組 連附件 () 其他 楊榮輝 連附件

分發其他分判：

- () 王禮秋 連附件

分發香港各部門：

- () 行政部 連附件 () 會計部 連附件 () 統籌部 連附件 () 工程部地盤科文 連附件
 () 採購部 連附件 () QS 部 連附件 () 維修部 連附件 () 其他 _____ 連附件

傳遞編號：

HK 1417 / 18

發件人簽署：

項目經理簽署：

Page	PART	Grade	Die No.	0	A	B	C	D	
1	M1	6063	T6	LH0089912	X85545	1	1		
2	M2	6063	T6	LH0089913	X85546	1	1		
3	M3	6063	T6	LH0089914	X85547	1			
4	M4	6063	T6	LH0089915	X85548	1		1	
5	M5	6063	T6		X85549	暫停	暫停	1	
6	M6	6063	T6	LH0089916	X85550	1			
7	M7	6063	T6	LH0089917	X85551	1		1	
8	T1	6063	T6	LH0089918	X85552	1	1		
9	T2	6063	T6	LH0089919	X85553	1			
10	T3	6063	T6	LH0089920	X85554	1			
11	T3A	6063	T6	LH0089921	X85555	1			
12	A01	6063	T5	LH0089922	X85556	1			
13	A02	6063	T6	LH0089923	X85557	1			
14	A03	6063	T6	LH0089924	X85558	1		1	
15	A04	6063	T6	LH0089925	X85559	1			
16	A05	6063	T6	LH0089926	X85560	1			
17	A06	6063	T6	LH0089927	X85561	1			
18	A07	6063	T6	LH0089928	X85562	1			
19	A08	6063	T5	LH0089929	X85563	1			
20	A09	6063	T5	LH0089930	X85564	1			
21	A10	6061	T6	LH0089931	X85565	1	1		
22	A11	6061	T6	LH0089932	X85566	1	1		
23	A12	6061	T6	LH0089933	X85567	1	1		
24	A13	6061	T6		X85568	暫停	暫停	1	
25	A14	6061	T6	LH0089934	X85569	1		1	
26	S01	6063	T6	LH0089935	X85570	1			
27	S02	6063	T5		X85571	暫停	暫停		
28	S03	6063	T6	LH0089936	X85572	1			
29	S04	6063	T6		X85573	暫停	暫停		
30	S05	6063	T6		X85574	暫停	暫停		
31	S06	6063	T6		X85575	暫停	暫停		
32	S07	6063	T6		X85576	暫停	暫停		
33	S08	6063	T6		X85577	暫停	暫停		
34	S09	6063	T5	LH0089937	X85578	1			
35	S10	6063	T6		X85579	暫停	暫停		
36	S12	6063	T6		X85580	暫停	暫停		
37	S13	6063	T6		X85581	暫停	暫停		
38	S15	6063	T6		X85582	暫停	暫停		
39	S16	6063	T6		X85583	暫停	暫停		
40	S17	6063	T5		X85584	暫停	暫停		
41	S18	6063	T6		X85585	暫停	暫停		
42	S19	6063	T6		X85586	暫停	暫停		
43	F01	6063	T6		X85587	暫停	暫停		
44	F02	6063	T6		X85588	暫停	暫停		
45	F03	6063	T5		X85589	暫停	暫停		
46	F04	6063	T6		X85590	暫停	暫停		
47	F05	6063	T6		X85591	暫停	暫停		
48	AB01	6061	T6	LH0089938	X85592	1	1		
49	AB2	6061	T6	LH0089939	X85593	1			
50	AB4	6061	T6	LH0089940	X85594	1			
51	AB5	6063	T5	LH0089941	X85595	1			
52	A15	6063	T6		X85596			1	
53	A16	6063	T5		X85597			1	
54	A17	6061	T6		X85598				
						30	4	3	8

CUSTOMER	CUSTOMER APPROVAL	CUST PART NO.	M4 LH0089915
		SECTION NO.	X855 48

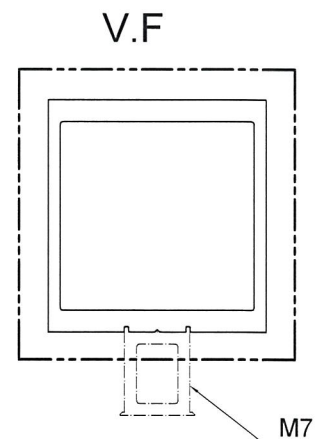
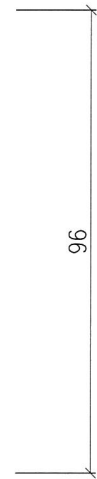
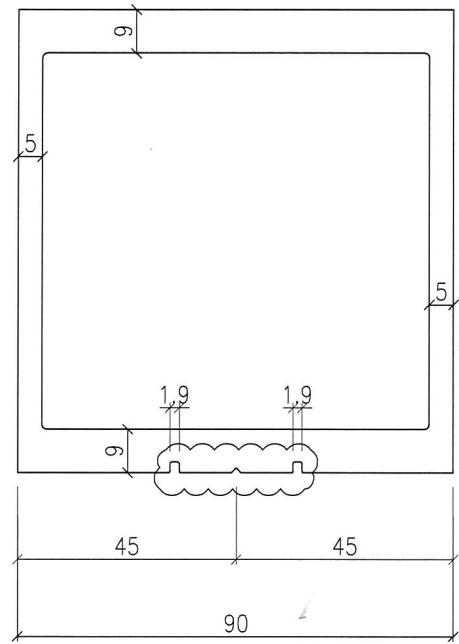

SCALE 1:2

SIGNATURE GRADEING	HIGH SIGNATURE GRADEING	C.C.DIA(MM)							
AREA (SQ MM)	2391.5	UNSPECIFIED THICKNESS	-	PERIMETER (MM)	-	STANDARD		SCALE	1:1
MASS (KG/M)	-	UNSPECIFIED CORNERS	-	SURFACE AREA	-	ALLOY	6063 T6	VERSION	A
COMPANY ISSUE			DRAWA		DATE	APELLATION		PAGE OF	
			STANDA-		DATE	 美特鋁質有限公司 MIDI Aluminium Fabricator Ltd.			
			RDIZATION		DATE				
			TO SIGN		DATE				
			AUDITING		DATE				
MARKER	MODIFY	FILE NO	SIGNATURE	DATE	APPROV				

CUSTOMER	CUSTOMER APPROVAL	CUST PART NO.	M5
		SECTION NO.	X85549

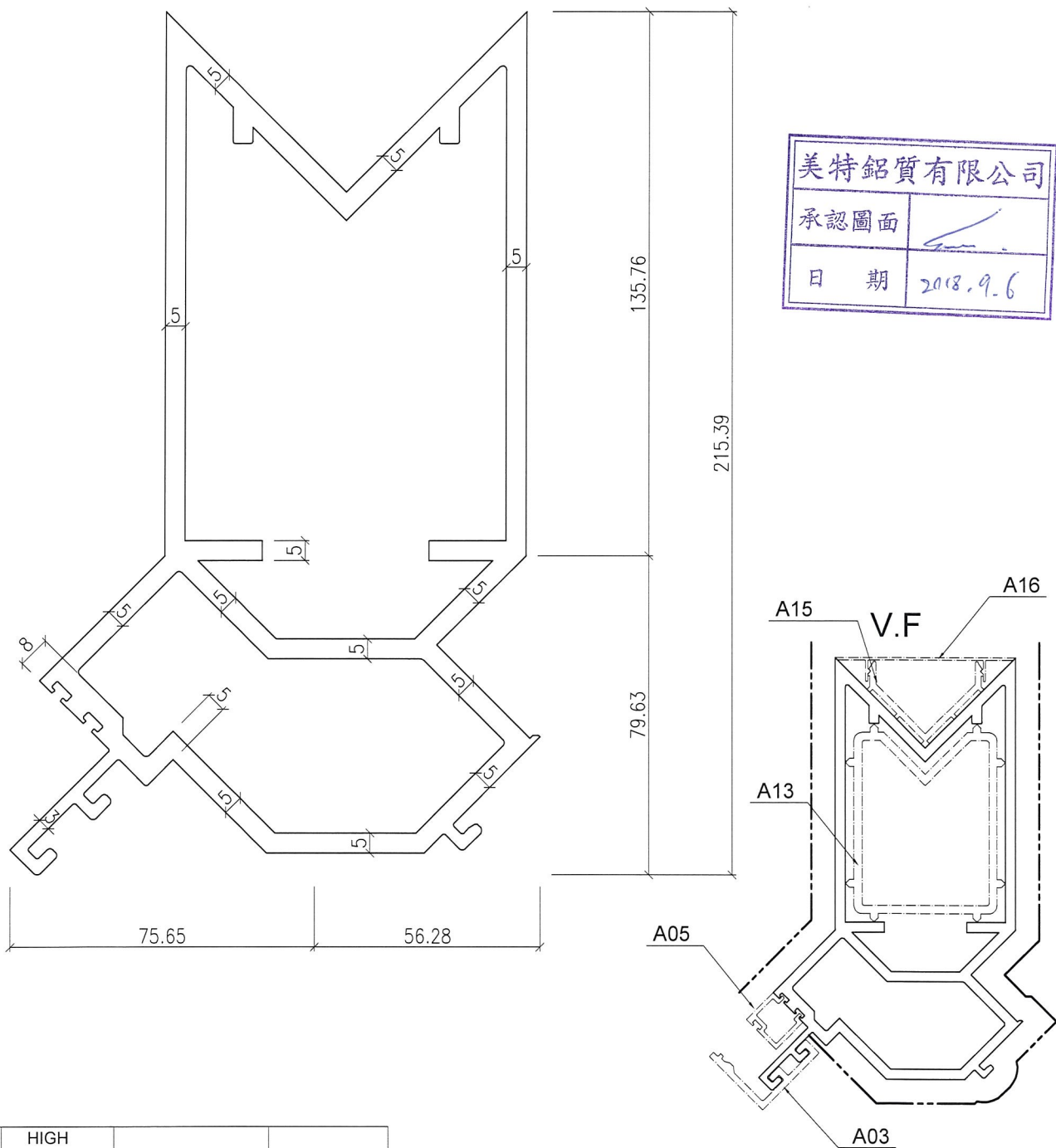

美特鋁質有限公司
承認圖面
日期 2018.9.6

SIGNATURE GRADEING	HIGH SIGNATURE GRADEING	C.C.DIA(MM)							
AREA (SQ MM)	4006.3	UNSPECIFIED THICKNESS	-	PERIMETER (MM)	-	STANDARD		SCALE	1:1
MASS (KG/M)	-	UNSPECIFIED CORNERS	-	SURFACE AREA	-	ALLOY	6063 T6	VERSION	
COMPANY ISSUE			DRAWN	DATE	APPELLATION		-	PAGE OF	
			STANDARDIZATION	DATE					
			TO SIGN	DATE					
			AUDITING	DATE					
MARKER	MODIFY	FILE NO	SIGNATURE	DATE	APPROV				

美特鋁質有限公司
MIDI Aluminium Fabricator Ltd.

CUSTOMER	CUSTOMER APPROVAL	CUST PART NO.	M7 LH0089917
		SECTION NO.	X85551

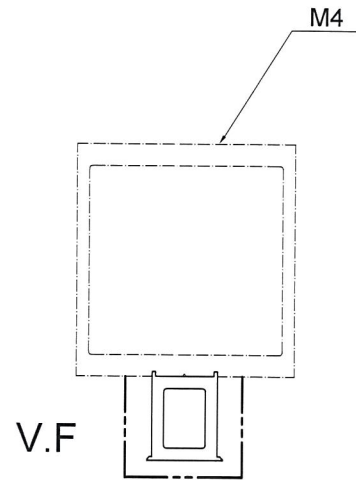
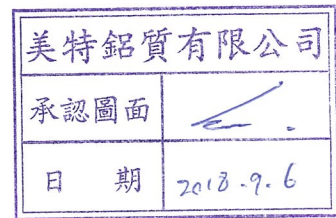
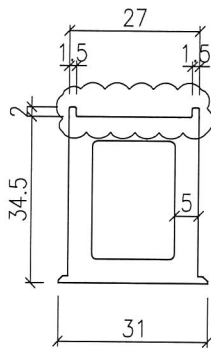

SCALE 1:2

SIGNATURE GRADEING	HIGH SIGNATURE GRADEING	C.C.DIA(MM)							
AREA (SQ MM)	526.81	UNSPECIFIED THICKNESS	-	PERIMETER (MM)	-	STANDARD		SCALE	1:1
MASS (KG/M)	-	UNSPECIFIED CORNERS	-	SURFACE AREA	-	ALLOY	6063 T6	VERSION	A
COMPANY ISSUE			DRAWN	DATE	APPELLATION	-	PAGE OF		
			STANDARDIZATION	DATE					
			TO SIGN	DATE					
			AUDITING	DATE					
MARKER	MODIFY	FILE NO	SIGNATURE	DATE	APPROV				

CUSTOMER	CUSTOMER APPROVAL	CUST PART NO.	A03 LH0089924
		SECTION NO.	X85 558

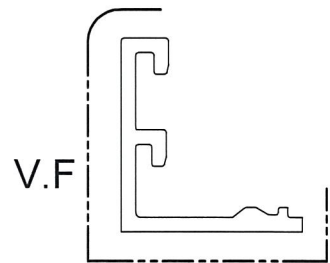
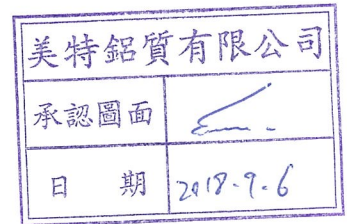
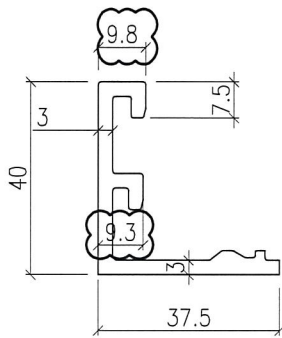

SCALE 1:1

SIGNATURE GRADEING	HIGH SIGNATURE GRADEING	C.C.DIA(MM)							
AREA (SQ MM)	304.55	UNSPECIFIED THICKNESS	-	PERIMETER (MM)	-	STANDARD		SCALE	1:1
MASS (KG/M)	-	UNSPECIFIED CORNERS	-	SURFACE AREA	-	ALLOY	6063 T6	VERSION	A
COMPANY ISSUE			DRAWA	DATE	APELLATION	-	PAGE OF		
			STANDA- RDIZATION	DATE	 美特鋁質有限公司 MIDI Aluminium Fabricator Ltd.				
			TO SIGN	DATE					
			AUDITING	DATE					
MARKER	MODIFY	FILE NO	SIGNATURE	DATE	APPROV				

CUSTOMER	CUSTOMER APPROVAL	CUST PART NO.	A13
		SECTION NO.	X85568

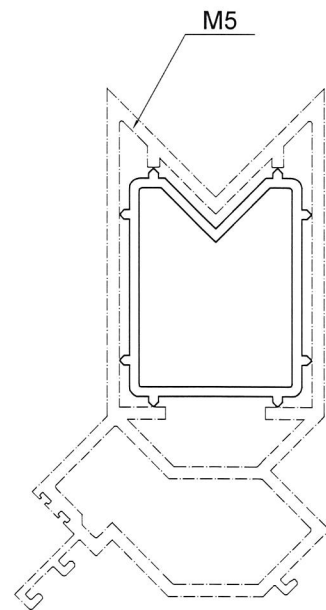
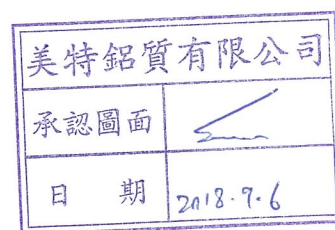
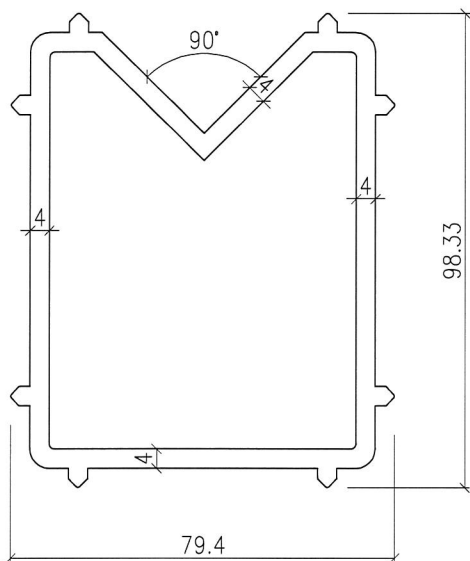

SCALE 1:2

SIGNATURE GRADEING	HIGH SIGNATURE GRADEING	C.C.DIA(MM)	不可有正公差						
AREA (SQ MM)	1391.1	UNSPECIFIED THICKNESS	-4 ⁺⁰ _{-0.3}	PERIMETER (MM)	-	STANDARD		SCALE	1:1
MASS (KG/M)	-	UNSPECIFIED CORNERS	-	SURFACE AREA	-	ALLOY	6061 T6	VERSION	
COMPANY ISSUE			DRAWA	DATE	APELLATION		-	PAGE OF	
			STANDA-RDIZATION	DATE					
			TO SIGN	DATE					
			AUDITING	DATE					
MARKER	MODIFY	FILE NO	SIGNATURE	DATE	APPROV	DATE			

CUSTOMER	CUSTOMER APPROVAL	CUST PART NO.	A14 LH0089934
		SECTION NO.	X85569

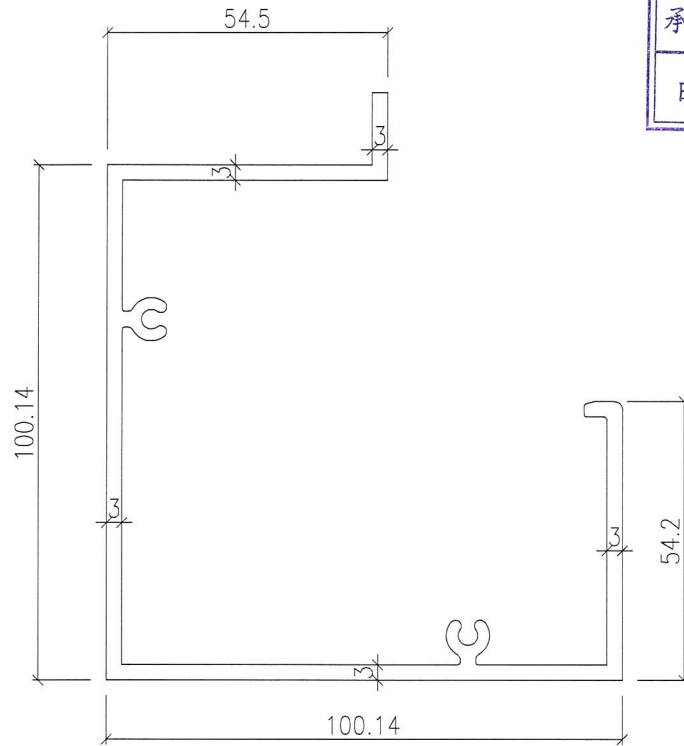

美特鋁質有限公司	
承認圖面	
日期	2018.8.6

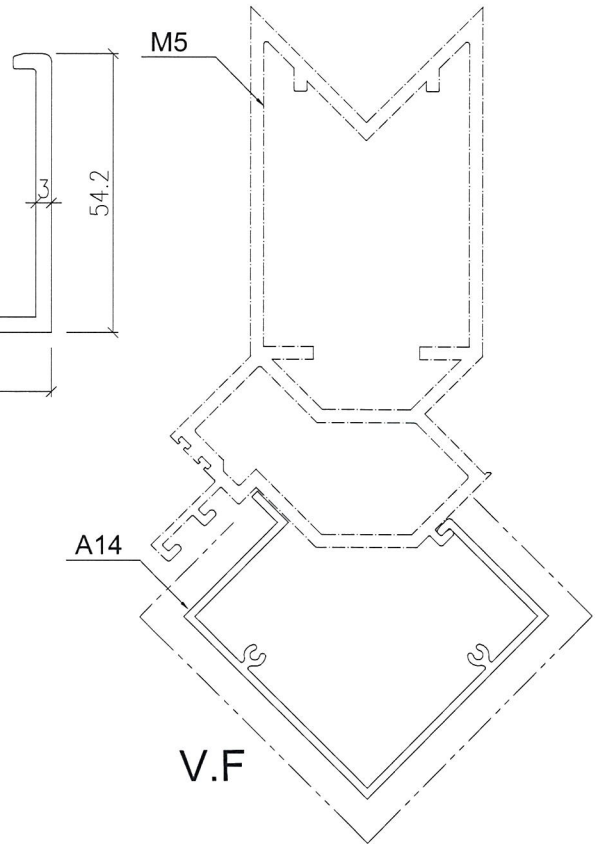

SCALE 1:2

SIGNATURE GRADEING	HIGH SIGNATURE GRADEING	C.C.DIA(MM)							
AREA (SQ MM)	1035.4	UNSPECIFIED THICKNESS	-	PERIMETER (MM)	-	STANDARD		SCALE	1:1
MASS (KG/M)	-	UNSPECIFIED CORNERS	-	SURFACE AREA	-	ALLOY	6063 T6	VERSION	A
COMPANY ISSUE			DRAWN	DATE		APPELLATION	-	PAGE OF	
			STANDARDIZATION	DATE					
			TO SIGN	DATE					
			AUDITING	DATE					
MARKER	MODIFY	FILE NO	SIGNATURE	DATE	APPROV				

CUSTOMER		CUSTOMER APPROVAL	CUST PART NO.	A15
			SECTION NO.	X85596

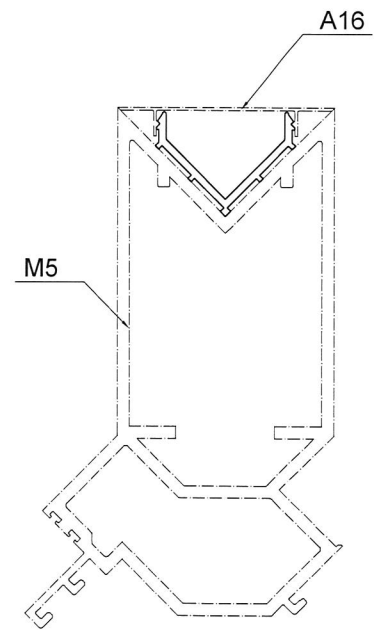
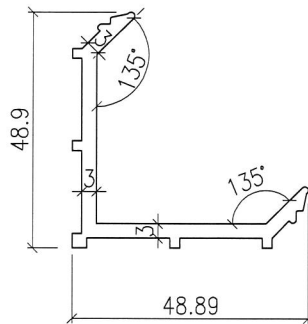
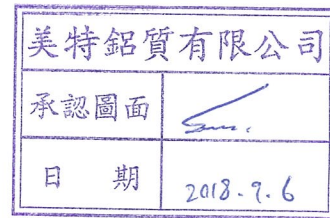

SCALE 1:2

SIGNATURE GRADEING	HIGH SIGNATURE GRADEING	C.C.DIA(MM)							
	315.64	UNSPECIFIED THICKNESS	-	PERIMETER (MM)	-	STANDARD		SCALE	1:1
	-	UNSPECIFIED CORNERS	-	SURFACE AREA	-	ALLOY	6063 T6	VERSION	
COMPANY ISSUE			DRAWN	DATE		APPELLATION	-	PAGE OF	
			STANDARDIZATION	DATE		 美特鋁質有限公司 MIDI Aluminium Fabricator Ltd.			
			TO SIGN	DATE					
			AUDITING	DATE					
MODIFY	FILE NO	SIGNATURE	DATE	APPROV	DATE				

CUSTOMER		CUSTOMER APPROVAL		CUST PART NO.	A16
				SECTION NO.	X85597

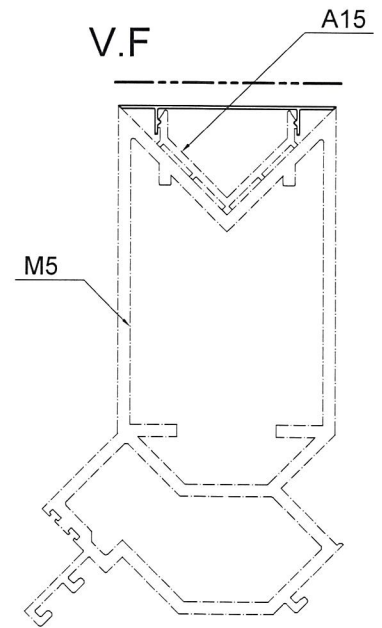
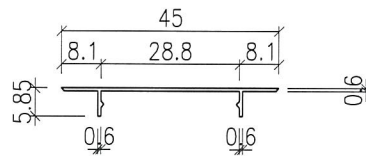
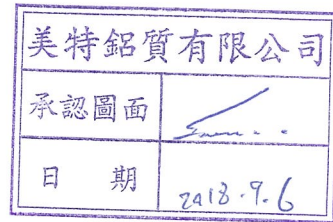

SIGNATURE GRADEING	HIGH SIGNATURE GRADEING	C.C.DIA(MM)							
	33.87	UNSPECIFIED THICKNESS	-	PERIMETER (MM)	-	STANDARD		SCALE	1:1
	-	UNSPECIFIED CORNERS	-	SURFACE AREA	-	ALLOY	6063 T5	VERSION	
COMPANY ISSUE			DRAWA	DATE		APPELLATION	-	PAGE OF	
			STANDA- RDIZATION	DATE		 美特鋁質有限公司 MIDI Aluminium Fabricator Ltd.			
			TO SIGN	DATE					
			AUDITING	DATE					
			APPROV	DATE					
MODIFY	FILE NO	SIGNATURE	DATE	APPROV	DATE				