

工程指示 / 要求簡箋(E.I.)

工程指示編號：EI / 0190 / 18

修改版次：A

工程編號：J837 平台

工程名稱：觀塘 裕民坊

工程項目：平台鋁飾線和百業

廠用鋁料 BM

收件人

Maggie

發件人：Leung Hin Wai

日期：30/4 2019

要求提供 /  確認 事項：

- |                                    |                                     |                               |
|------------------------------------|-------------------------------------|-------------------------------|
| <input type="checkbox"/> 初步鋁料 B.M. | <input type="checkbox"/> 加工拆圖，然後生產  | <input type="checkbox"/> 尺寸表  |
| <input type="checkbox"/> 正式鋁料 B.M. | <input type="checkbox"/> 技術上資料 / 指示 | <input type="checkbox"/> 報價   |
| <input type="checkbox"/> 配件 B.M.   | <input type="checkbox"/> 樣辦或貨品說明書   | <input type="checkbox"/> 分判合約 |
| <input type="checkbox"/> 其他：_____  |                                     |                               |

內容：

確定和修改拉彎圖。

請在 \_\_\_\_\_ 前完成上列要求。

附：-

1 + 36 頁

以上項目為：

- 原合約工程包                       原合約工程加 / 減賬                       新工程報價

原因：-

分發東莞各部門：

- ( ) 生產技術總監  連附件    ( ) 技術部  連附件    ( ) 生產部  連附件    ( ) 機械設計部  連附件  
 ( ) 採購部  連附件    ( / ) 生產統籌部  連附件  
 ( ) 質檢部  連附件    ( ) 會計部  連附件    ( ) 報關組  連附件    ( ) 其他 \_\_\_\_\_  連附件

分發香港各部門：

- ( ) 行政部  連附件    ( ) 會計部  連附件    ( ) 統籌部  連附件    ( ) 工程部地盤科文  連附件  
 ( ) 採購部  連附件    ( ) QS 部  連附件    ( ) 維修部  連附件    ( ) 其他 \_\_\_\_\_  連附件

傳遞編號：

JA 及 1017

發件人簽署：

項目經理簽署：

## EI0190

序號	美特圖號	榮陽圖號	
1	J837-WH- 04	LH0090 289(F06)	確定
2	J837-WH- 05	LH0090 290(F06)	確定
3	J837-WH- 06	LH0090 166(F01)	修改
4	J837-WH- 07	LH0090 165(F01)	確定
5	J837-WH- 08	LH0090 167(F01)	確定
6	J837-WH- 09	PE0E10 027(F10)	確定
7	J837-WH- 10	PE00E3 465(F06)	確定
8	J837-WH- 11	LH0090 289(F07)	確定
9	J837-WH- 12	LH0090 290(F07)	確定
10	J837-WH- 13	LH0090 166(F02)	確定
11	J837-WH- 14	LH0090 165(F02)	確定
12	J837-WH- 15	LH0090 167(F02)	確定
13	J837-WH- 16	PE0E10 027(F09)	確定
14	J837-WH- 17	PE00E3 465(F07)	確定
15	J837-WH- 18	LH0090 289(F08)	確定
16	J837-WH- 19	LH0090 290(F08)	確定
17	J837-WH- 20	LH0090 166(F03)	確定
18	J837-WH- 21	LH0090 165(F03)	確定
19	J837-WH- 22	LH0090 167(F03)	確定
20	J837-WH- 23	PE0E10 027(F11)	確定
21	J837-WH- 24	PE00E3 465(F08)	確定
22	J837-WH- 25	LH0090 289(F09)	修改
23	J837-WH- 26	LH0090 290(F09)	確定
24	J837-WH- 27	LH0090 166(F04)	確定
25	J837-WH- 28	LH0090 165(F04)	確定
26	J837-WH- 29	LH0090 167(F04)	確定
27	J837-WH- 30	PE0E10 027(F12)	確定
28	J837-WH- 31	PE00E3 465(F09)	確定
29	J837-WH- 32	LH0090 289(F10)	確定
30	J837-WH- 33	LH0090 290(F10)	確定
31	J837-WH- 34	LH0090 166(F05)	確定
32	J837-WH- 35	LH0090 165(F05)	確定
33	J837-WH- 36	LH0090 167(F05)	確定
34	J837-WH- 37	PE0E10 027(F13)	確定
35	J837-WH- 38	PE00E3 465(F10)	確定

CUSTOMER	HONGKONG CO.	CUSTOMER APPROVAL	CUST PART NO.	J837-WH-04
			SECTION NO.	LH0090289(F06)

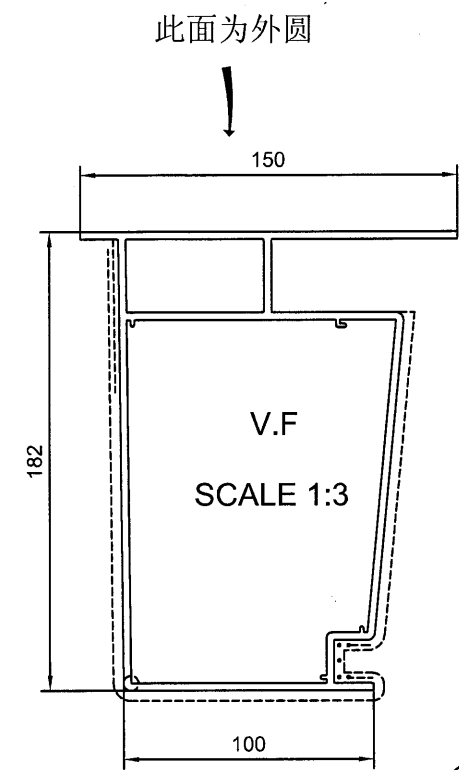

美特铝质有限公司	
承认图面	<i>[Signature]</i>
日期	30/4-2019

SECTION A-A

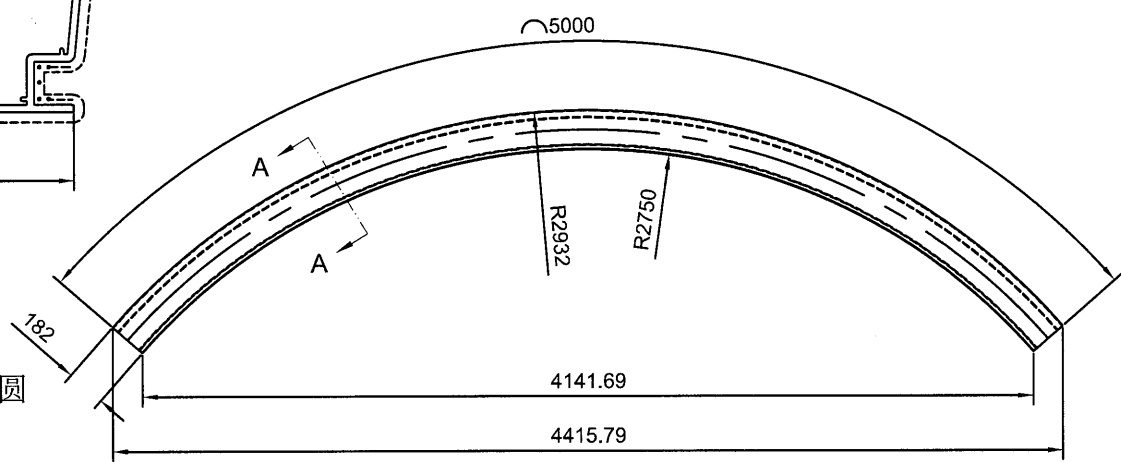

此面为内圆

技术要求:

- 1.平面度偏差0~1.0mm;
- 2.扭拧度偏差0~5.0mm;
- 3.角度变形±1.5°;
- 4.产品未注公差±3.0mm;
- 5.允许两端各预留10mm钳口位。

拉弯前展开长度: 4844.82 mm

外弧长度: 5000 mm

Total weight: 28.793 kg/pcs

Unspecified Fabricated Tolerance:±3.0

SIGNATURE GRADEING	HIGH SIGNATURE GRADEING	C.C.DIA(MM)	Ø225.3						
AREA (SQ MM)	2193.12	UNSPECIFIED THICKNESS	3±0.25	PERIMETER (MM)	782.82	STANDARD	BS EN755	SCALE	1:35
MASS (KG/M)	5.943	UNSPECIFIED CORNERS	R 0.3	SURFACE AREA	460.12	ALLOY	6063-T6	VERSION	B
		DRAWN	陈晓舒	DATE	2019-04-12	APPELLATION	-	PAGE OF	
		STANDARDIZATION		DATE					
		TO SIGN	陈国提	DATE					
		AUDITING		DATE					
MARKER	MODIFY	FILE NO	SIGNATURE	DATE	APPROV				

CUSTOMER	HONGKONG CO.	CUSTOMER APPROVAL	CUST PART NO.	J837-WH-05
			SECTION NO.	LH0090290(F06)

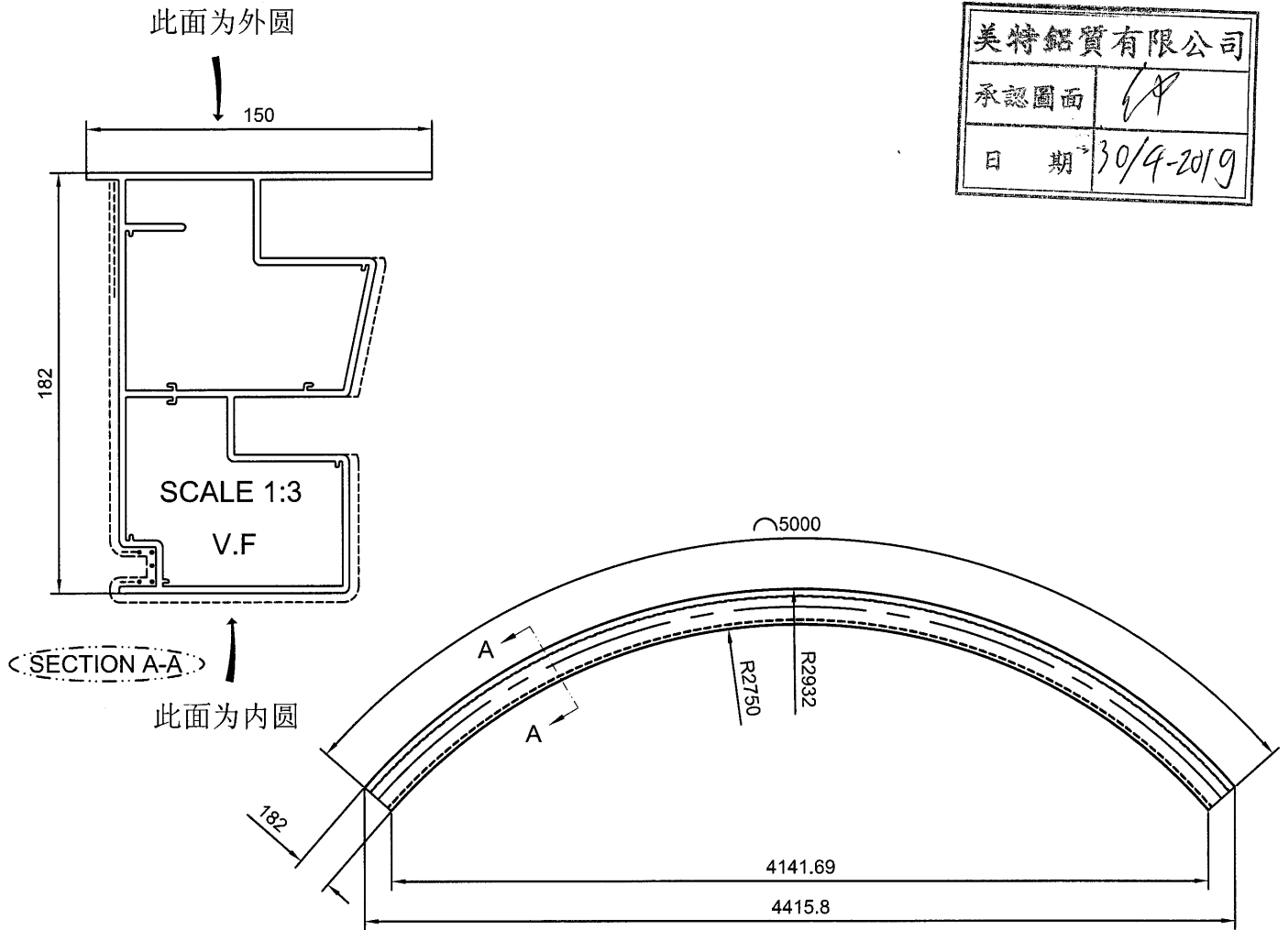

美特铝质有限公司  
 承認圖面  
 日期 30/4-2019

技术要求:

- 1.平面度偏差0~1.0mm;
- 2.扭拧度偏差0~5.0mm;
- 3.角度变形±1.5°;
- 4.产品未注公差±3.0mm;
- 5.允许两端各预留10mm钳口位。

Total weight: 33.415 kg/pcs  
 Unspecified Fabricated Tolerance:±3.0

拉弯前展开长度: 4844.82 mm  
 外弧长度: 5000 mm

SIGNATURE GRADEING	HIGH SIGNATURE GRADEING	C.C.DIA(MM)	Ø227.56						
AREA (SQ MM)	2545.02	UNSPECIFIED THICKNESS	3±0.25	PERIMETER (MM)	878.28	STANDARD	BS EN755	SCALE	1:35
MASS (KG/M)	6.897	UNSPECIFIED CORNERS	R 0.3	SURFACE AREA	434.22	ALLOY	6063-T6	VERSION	B
		DRAWN	陈晓舒	DATE	2019-04-12	APELLATION	-	PAGE OF	
		STANDARDIZATION		DATE					
		TO SIGN	陈国提	DATE					
		AUDITING		DATE					
MARKER	MODIFY	FILE NO	SIGNATURE	DATE	APPROV	DATE			



CUSTOMER	HONGKONG CO.	CUSTOMER APPROVAL	CUST PART NO.	J837-WH-07
			SECTION NO.	LH0090165(F01)

此面为外圆

美特铝质有限公司	
承认图面	
日期	30/4-2019

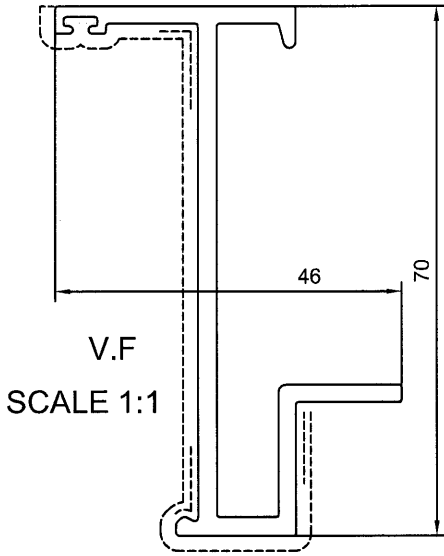

SECTION A-A

此面为内圆

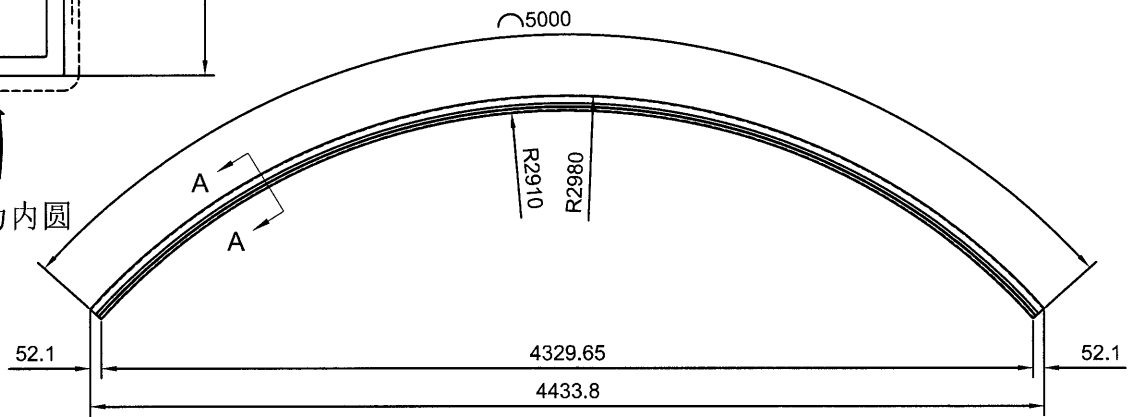

技术要求:

- 1.平面度偏差0~1.0mm;
- 2.扭拧度偏差0~5.0mm;
- 3.角度变形±1.5°;
- 4.产品未注公差±3.0mm;
- 5.允许两端各预留10mm钳口位。

Total weight: 4.749 kg/pcs

Unspecified Fabricated Tolerance:±3.0

拉弯前展开长度: 4941.28 mm

外弧长度: 5000 mm

SIGNATURE GRADEING	HIGH SIGNATURE GRADEING	C.C.DIA(MM)	Ø76.78						
AREA (SQ MM)	354.71	UNSPECIFIED THICKNESS	2.3±0.2	PERIMETER (MM)	307.08	STANDARD	BS EN755	SCALE	1:35
MASS (KG/M)	0.961	UNSPECIFIED CORNERS	R 0.3	SURFACE AREA	135.52	ALLOY	6063-T6	VERSION	B
		DRAWN	陈晓舒	DATE	2019-04-12	APPELLATION	-	PAGE OF	
		STANDARDIZATION		DATE					
		TO SIGN	陈国提	DATE					
		AUDITING		DATE					
MARKER	MODIFY FILE NO	SIGNATURE	DATE	APPROV	DATE				

CUSTOMER	HONGKONG CO.	CUSTOMER APPROVAL	CUST PART NO.	J837-WH-08
			SECTION NO.	LH0090167(F01)

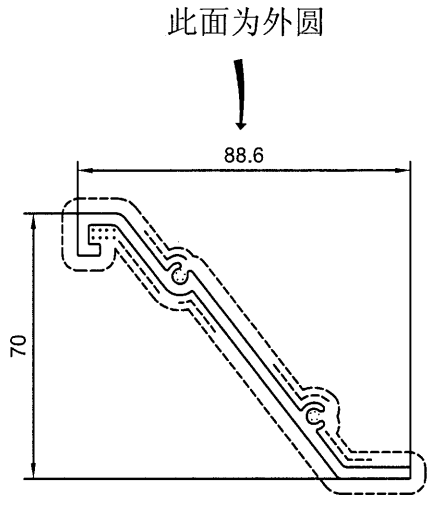

美特铝质有限公司	
承认图面	<i>[Signature]</i>
日期	30/4-2019

V.F  
SCALE 1:2

SECTION A-A

此面为内圆

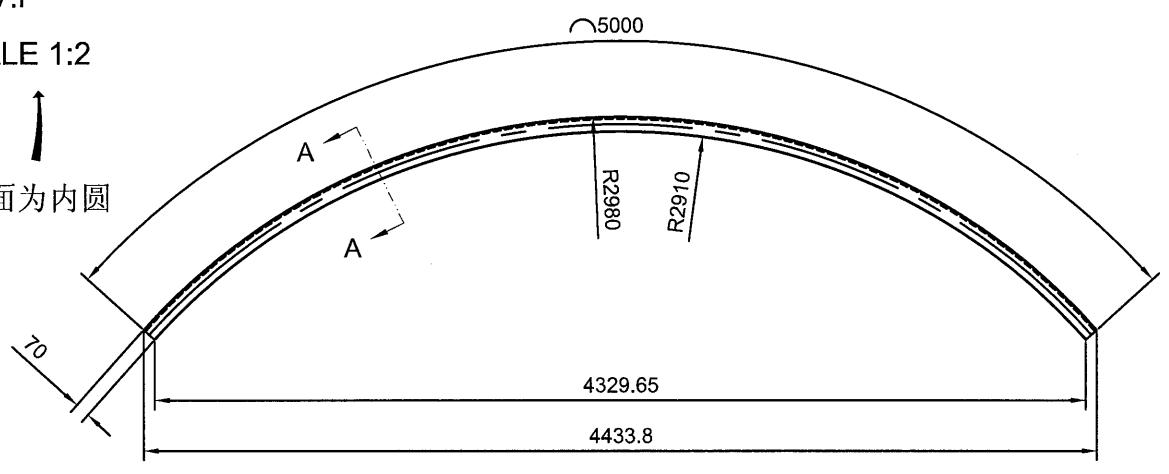

技术要求:

- 1.平面度偏差0~1.0mm;
- 2.扭拧度偏差0~5.0mm;
- 3.角度变形±1.5°;
- 4.产品未注公差±3.0mm;
- 5.允许两端各预留10mm钳口位。

Total weight:5.712 kg/pcs  
Unspecified Fabricated Tolerance:±3.0

拉弯前展开长度: 4941.28 mm  
外弧长度: 5000 mm

SIGNATURE GRADEING	HIGH SIGNATURE GRADEING	C.C.DIA(MM)	Ø135.52							
AREA (SQ MM)	426.67	UNSPECIFIED THICKNESS	3±0.25	PERIMETER (MM)	296.71	STANDARD	BS EN755	SCALE	1:35	
MASS (KG/M)	1.156	UNSPECIFIED CORNERS	R 0.3	SURFACE AREA	296.71	ALLOY	6063-T6	VERSION	B	
		DRAWN	陈晓舒	DATE	2019-04-12	APELLATION	-	PAGE OF		
		STANDARDIZATION		DATE						
		TO SIGN	陈国提	DATE						
		AUDITING		DATE						
MARKER	MODIFY	FILE NO	SIGNATURE	DATE	APPROV					

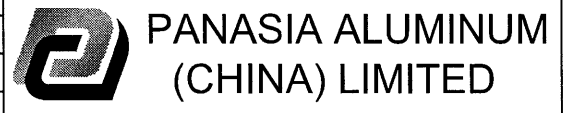

CUSTOMER	HONGKONG CO.	CUSTOMER APPROVAL	CUST PART NO.	J837-WH-09
			SECTION NO.	PE0E10027(F10)

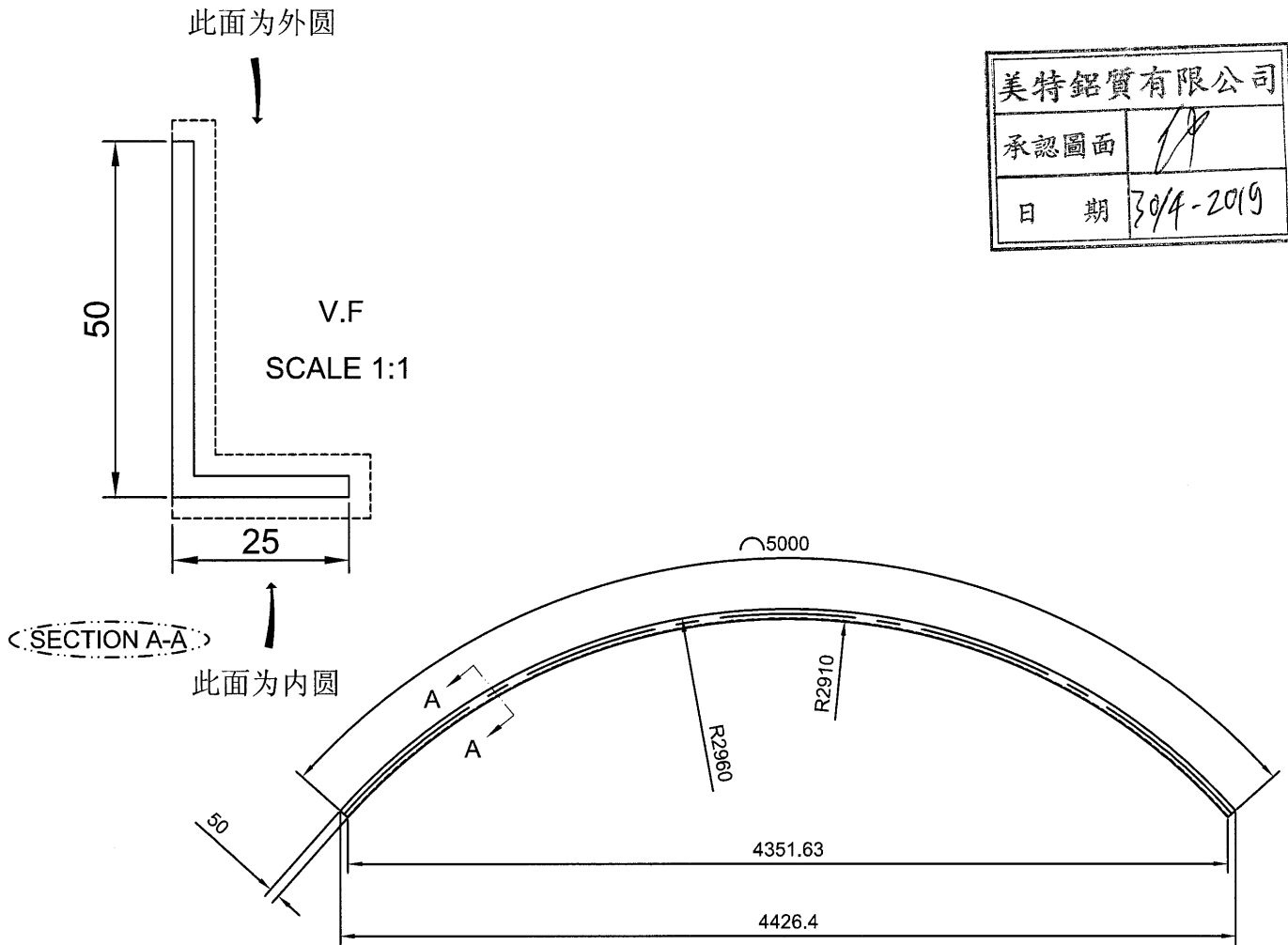

美特铝质有限公司	
承认图面	<i>[Signature]</i>
日期	3/4-2019

技术要求:

- 1.平面度偏差0~1.0mm;
- 2.扭拧度偏差0~5.0mm;
- 3.角度变形±1.5°;
- 4.产品未注公差±3.0mm;
- 5.允许两端各预留10mm钳口位。

Total weight:2.900 kg/pcs

Unspecified Fabricated Tolerance:±3.0

拉弯前展开长度: 4957.77 mm

外弧长度: 5000 mm

SIGNATURE GRADEING	HIGH SIGNATURE GRADEING	C.C.DIA(MM)	Ø55.9						
AREA (SQ MM)	216	UNSPECIFIED THICKNESS	3±0.15	PERIMETER (MM)	150	STANDARD	BS EN755	SCALE	1:35
MASS (KG/M)	0.585	UNSPECIFIED CORNERS	R 0.3	SURFACE AREA	100	ALLOY	6063-T6	VERSION	B
		DRAWN	陈晓舒	DATE	2019-04-12	APPELLATION	-	PAGE OF	
		STANDARDIZATION		DATE					
		TO SIGN	陈国提	DATE					
		AUDITING		DATE					
MARKER	MODIFY	FILE NO	SIGNATURE	DATE	APPROV	DATE			



CUSTOMER	HONGKONG CO.	CUSTOMER APPROVAL	CUST PART NO.	J837-WH-10
			SECTION NO.	PE00E3465(F06)

此面为外圆

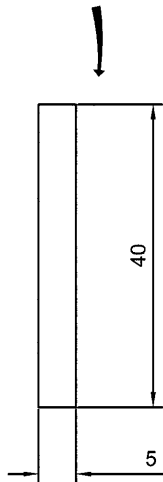

SECTION A-A

此面为内圆

SCALE 1:1

美特铝质有限公司	
承認圖面	
日期	30/4-2019

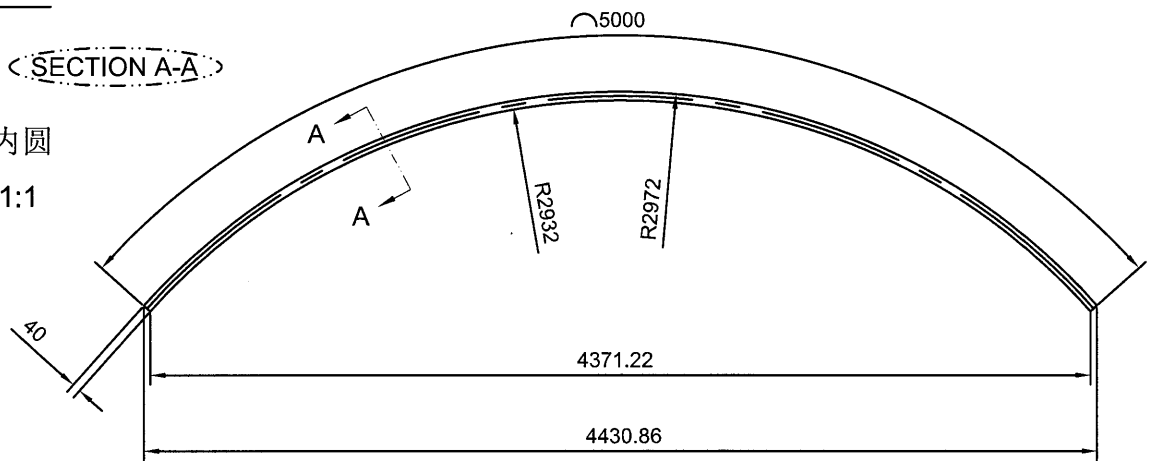

技术要求:

- 1.平面度偏差0~1.0mm;
- 2.扭拧度偏差0~5.0mm;
- 3.角度变形±1.5°;
- 4.产品未注公差±3.0mm;
- 5.允许两端各预留10mm钳口位。

Total weight:2.692 kg/pcs

Unspecified Fabricated Tolerance:±3.0

拉弯前展开长度: 4966.36 mm

外弧长度: 5000 mm

SIGNATURE GRADEING	HIGH SIGNATURE GRADEING	C.C.DIA(MM)	Ø40.31						
AREA (SQ MM)	200	UNSPECIFIED THICKNESS	-	PERIMETER (MM)	90	STANDARD	BS EN755	SCALE	1:35
MASS (KG/M)	0.542	UNSPECIFIED CORNERS	-	SURFACE AREA	-	ALLOY	6063-T6	VERSION	B
-	-	DRAWN	陈晓舒	DATE	2019-04-12	APPELLATION	-	PAGE OF	
		STANDARDIZATION		DATE					
		TO SIGN	陈国提	DATE					
		AUDITING		DATE					
MARKER	MODIFY	FILE NO	SIGNATURE	DATE	APPROV	DATE			

CUSTOMER	HONGKONG CO.	CUSTOMER APPROVAL	CUST PART NO.	J837-WH-11
			SECTION NO.	LH0090289(F07)

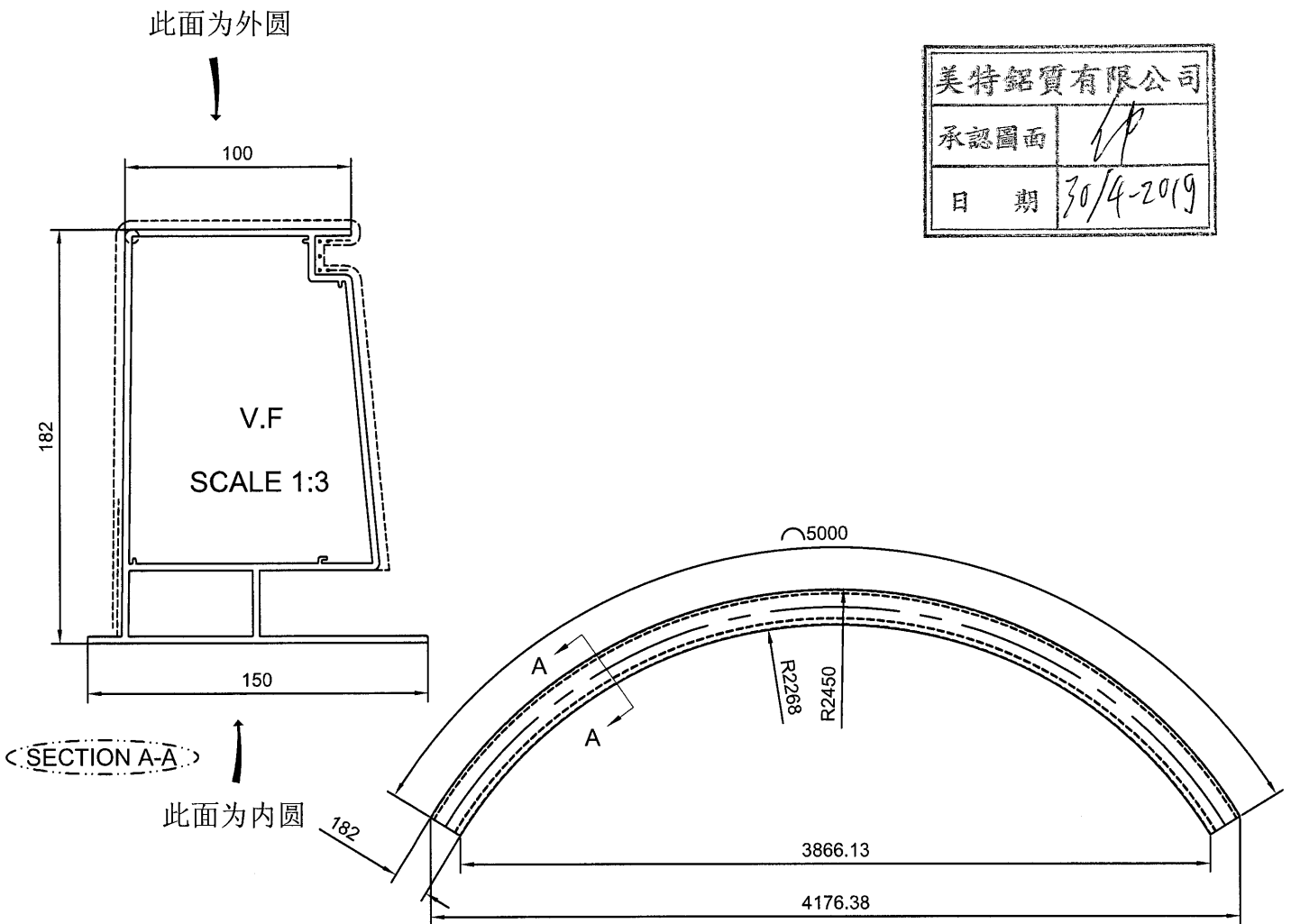

技术要求:

- 1.平面度偏差0~1.0mm;
- 2.扭拧度偏差0~5.0mm;
- 3.角度变形±1.5°;
- 4.产品未注公差±3.0mm;
- 5.允许两端各预留10mm钳口位。

拉弯前展开长度: 4814.29 mm

外弧长度: 5000 mm

Total weight: 28.611 kg/pcs  
 Unspecified Fabricated Tolerance:±3.0

SIGNATURE GRADEING	HIGH SIGNATURE GRADEING	C.C.DIA(MM)	Ø225.3								
AREA (SQ MM)	2193.12	UNSPECIFIED THICKNESS	3±0.25	PERIMETER (MM)	782.82	STANDARD	BS EN755	SCALE	1:35		
MASS (KG/M)	5.943	UNSPECIFIED CORNERS	R 0.3	SURFACE AREA	460.12	ALLOY	6063-T6	VERSION	B		
		DRAWN	陈晓舒	DATE	2019-04-12	APPELLATION			PAGE OF		
		STANDARDIZATION		DATE							
		TO SIGN	陈国提	DATE							
		AUDITING		DATE							
MARKER	MODIFY	FILE NO	SIGNATURE	DATE	APPROV	DATE					



CUSTOMER	HONGKONG CO.	CUSTOMER APPROVAL	CUST PART NO.	J837-WH-12
			SECTION NO.	LH0090290(F07)

此面为外圆

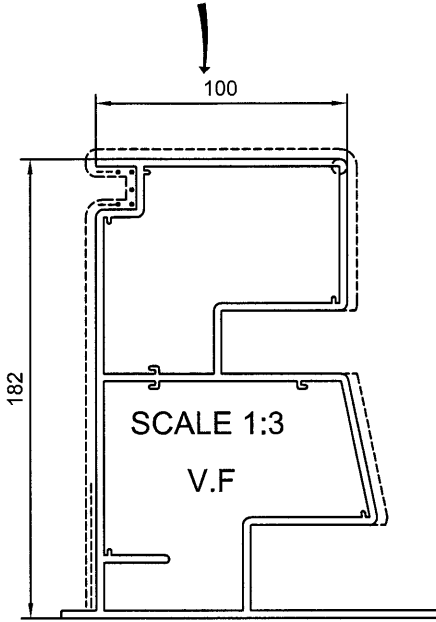

美特铝质有限公司	
承認圖面	<i>[Signature]</i>
日期	30/4-2019

SECTION A-A

此面为内圆

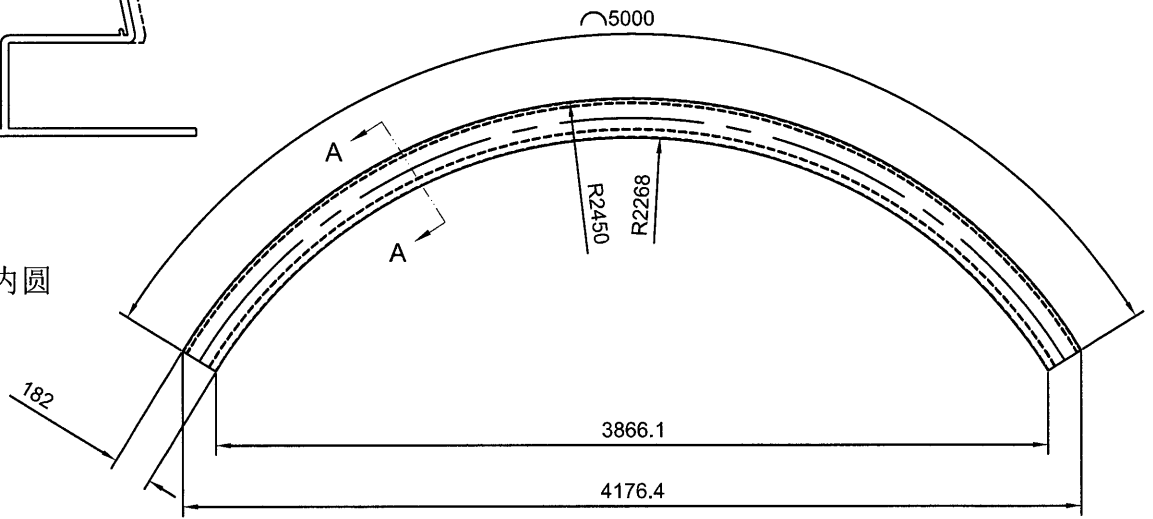

技术要求:

- 1.平面度偏差0~1.0mm;
- 2.扭拧度偏差0~5.0mm;
- 3.角度变形±1.5°;
- 4.产品未注公差±3.0mm;
- 5.允许两端各预留10mm钳口位。

Total weight: 33.204 kg/pcs

Unspecified Fabricated Tolerance:±3.0

拉弯前展开长度: 4814.29 mm

外弧长度: 5000 mm

SIGNATURE GRADEING	HIGH SIGNATURE GRADEING	C.C.DIA(MM)	Ø227.56							
AREA (SQ MM)	2545.02	UNSPECIFIED THICKNESS	3±0.25	PERIMETER (MM)	878.28	STANDARD	BS EN755	SCALE	1:35	
MASS (KG/M)	6.897	UNSPECIFIED CORNERS	R 0.3	SURFACE AREA	434.22	ALLOY	6063-T6	VERSION	B	
-	-	DRAWN	陈晓舒	DATE	2019-04-12	APELLATION	-	PAGE OF		
		STANDARDIZATION		DATE						
		TO SIGN	陈国提	DATE						
		AUDITING		DATE						
MARKER	MODIFY	FILE NO	SIGNATURE	DATE	APPROV					

CUSTOMER	HONGKONG CO.	CUSTOMER APPROVAL	CUST PART NO.	J837-WH-13
			SECTION NO.	LH0090166(F02)

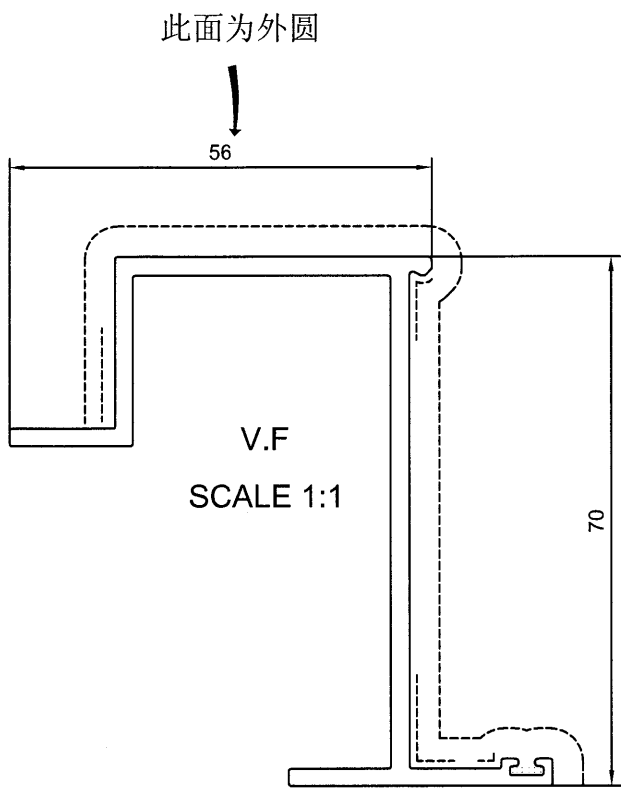

美特铝质有限公司	
承認圖面	<i>[Signature]</i>
日期	30/4-2019

< SECTION A-A >

此面为内圆

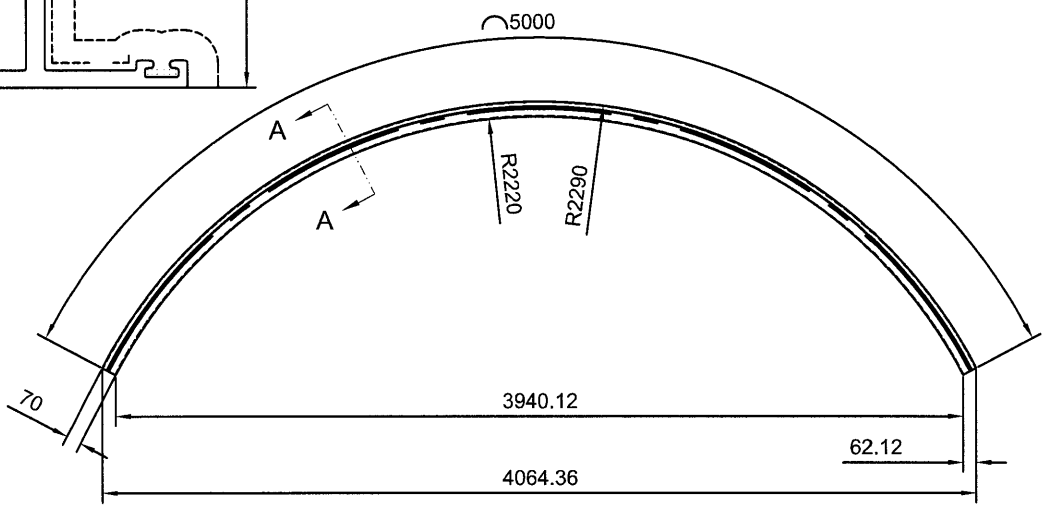

技术要求:

- 1. 平面度偏差0~1.0mm;
- 2. 扭拧度偏差0~5.0mm;
- 3. 角度变形±1.5°;
- 4. 产品未注公差±3.0mm;
- 5. 允许两端各预留10mm钳口位。

Total weight: 5.770 kg/pcs  
Unspecified Fabricated Tolerance:±3.0

拉弯前展开长度: 4923.58 mm  
外弧长度: 5000 mm

SIGNATURE GRADEING	HIGH SIGNATURE GRADEING	C.C.DIA(MM)	Ø93.07						
AREA (SQ MM)	432.6	UNSPECIFIED THICKNESS	2.3±0.2	PERIMETER (MM)	370.19	STANDARD	BS EN755	SCALE	1:35
MASS (KG/M)	1.172	UNSPECIFIED CORNERS	R 0.3	SURFACE AREA	166.52	ALLOY	6063-T6	VERSION	B
-	-	DRAWN	陈晓舒	DATE	2019-04-12	APELLATION	-	PAGE OF	
		STANDARDIZATION		DATE					
		TO SIGN	陈国提	DATE					
		AUDITING		DATE					
MARKER	MODIFY	FILE NO	SIGNATURE	DATE	APPROV	DATE			

CUSTOMER	HONGKONG CO.	CUSTOMER APPROVAL	CUST PART NO.	J837-WH-14
			SECTION NO.	LH0090165(F02)

此面为外圆

美特铝质有限公司	
承认图面	<i>Handwritten Signature</i>
日期	30/4-2019

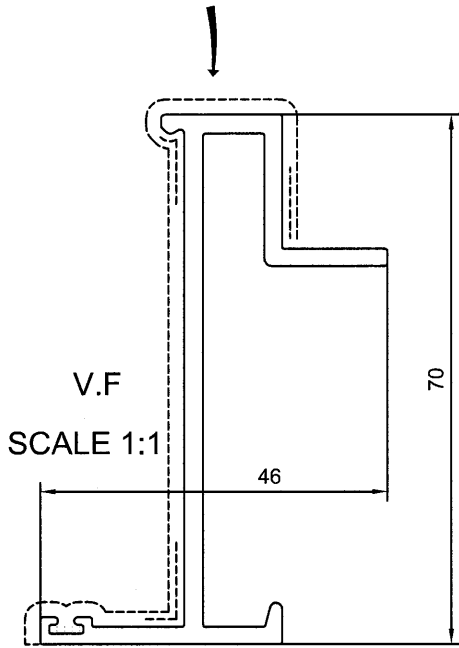

SECTION A-A

此面为内圆

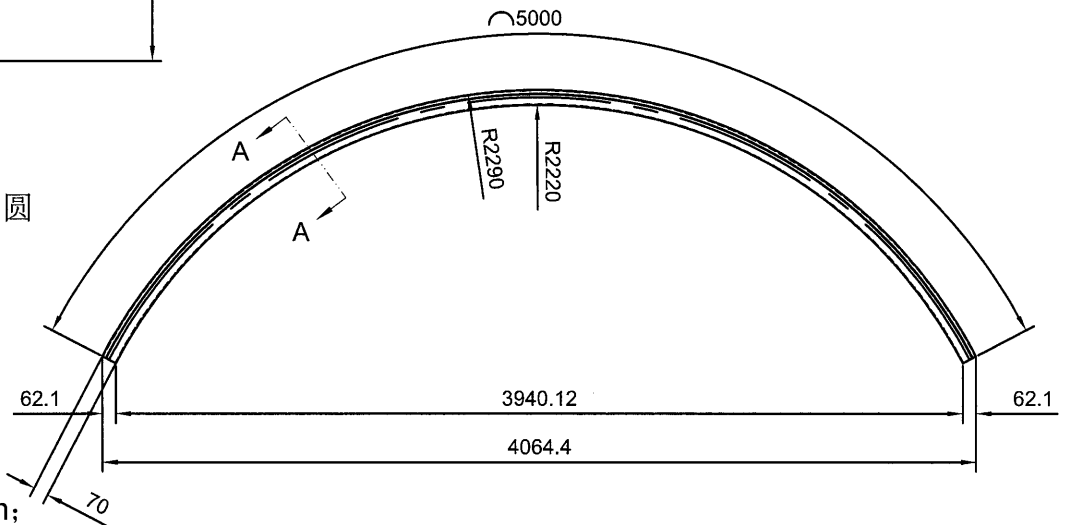

技术要求:

1. 平面度偏差0~1.0mm;
2. 扭拧度偏差0~5.0mm;
3. 角度变形 $\pm 1.5^\circ$ ;
4. 产品未注公差 $\pm 3.0$ mm;
5. 允许两端各预留10mm钳口位。

Total weight: 4.732 kg/pcs

Unspecified Fabricated Tolerance: $\pm 3.0$

拉弯前展开长度: 4923.58 mm

外弧长度: 5000 mm

SIGNATURE GRADEING	HIGH SIGNATURE GRADEING	C.C.DIA(MM)	$\varnothing 76.78$							
AREA (SQ MM)	354.71	UNSPECIFIED THICKNESS	$2.3 \pm 0.2$	PERIMETER (MM)	307.08	STANDARD	BS EN755	SCALE	1:35	
MASS (KG/M)	0.961	UNSPECIFIED CORNERS	R 0.3	SURFACE AREA	135.52	ALLOY	6063-T6	VERSION	B	
		DRAWN	陈晓舒	DATE	2019-04-12	APELLATION	-	PAGE OF		
		STANDARDIZATION		DATE						
		TO SIGN	陈国提	DATE						
		AUDITING		DATE						
MARKER	MODIFY	FILE NO	SIGNATURE	DATE	APPROV					

CUSTOMER	HONGKONG CO.	CUSTOMER APPROVAL	CUST PART NO.	J837-WH-15
			SECTION NO.	LH0090167(F02)

此面为外圆

美特铝质有限公司	
承认图面	<i>LB</i>
日期	30/4-2019

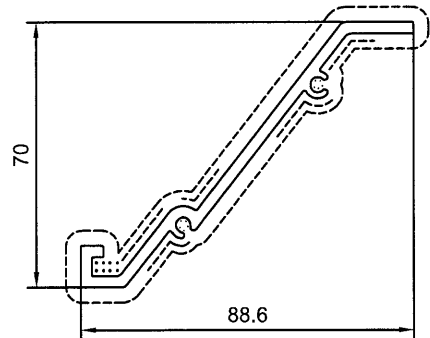

V.F  
SCALE 1:2  
SECTION A-A

此面为内圆

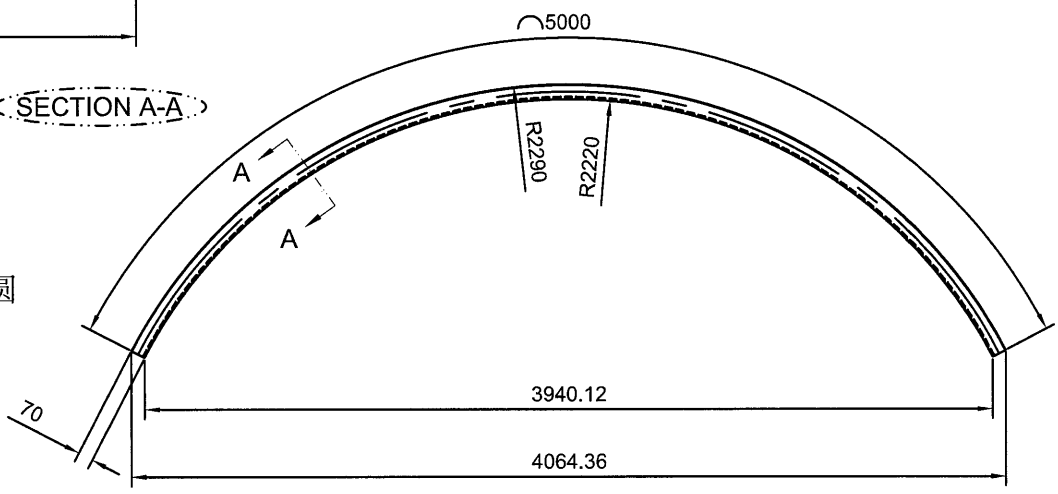

技术要求:

- 1.平面度偏差0~1.0mm;
- 2.扭拧度偏差0~5.0mm;
- 3.角度变形±1.5°;
- 4.产品未注公差±3.0mm;
- 5.允许两端各预留10mm钳口位。

Total weight:5.692 kg/pcs  
Unspecified Fabricated Tolerance:±3.0

拉弯前展开长度: 4923.58 mm  
外弧长度: 5000 mm

SIGNATURE GRADEING	HIGH SIGNATURE GRADEING	C.C.DIA(MM)	Ø135.52								
AREA (SQ MM)	426.67	UNSPECIFIED THICKNESS	3±0.25	PERIMETER (MM)	296.71	STANDARD	BS EN755	SCALE	1:35		
MASS (KG/M)	1.156	UNSPECIFIED CORNERS	R 0.3	SURFACE AREA	296.71	ALLOY	6063-T6	VERSION	B		
		DRAWN		陈晓舒	DATE	2019-04-12	APPELLATION	-			
		STANDARDIZATION			DATE						
		TO SIGN		陈国提	DATE						
		AUDITING			DATE						
MARKER	MODIFY	FILE NO	SIGNATURE	DATE	APPROV	DATE					

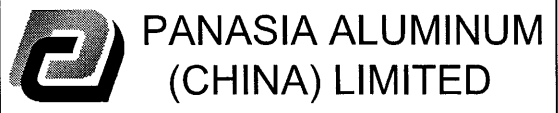

CUSTOMER	HONGKONG CO.	CUSTOMER APPROVAL	CUST PART NO.	J837-WH-16
			SECTION NO.	PE0E10027(F09)

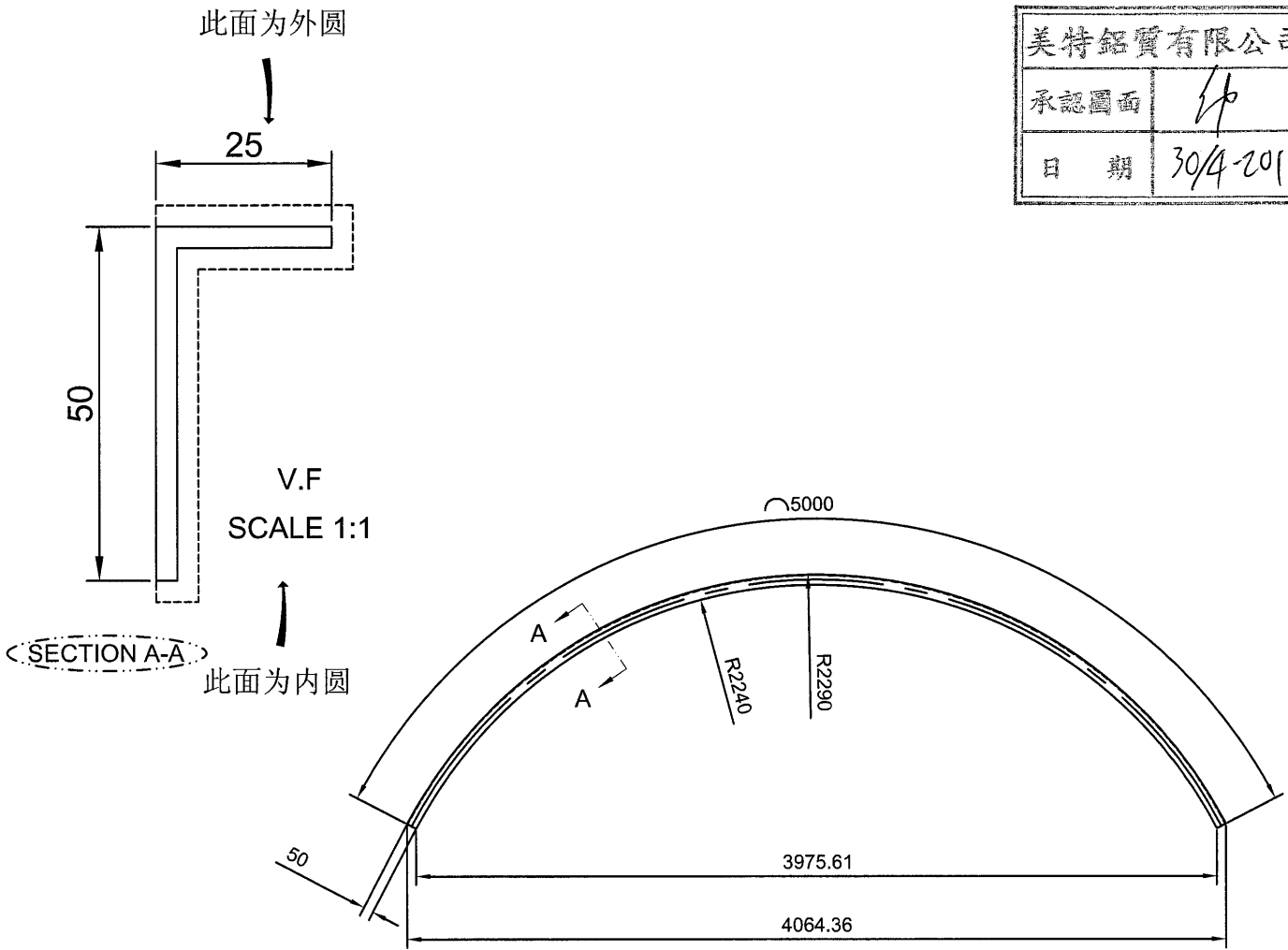

技术要求:

- 1.平面度偏差0~1.0mm;
- 2.扭拧度偏差0~5.0mm;
- 3.角度变形±1.5°;
- 4.产品未注公差±3.0mm;
- 5.允许两端各预留10mm钳口位。

Total weight:2.893 kg/pcs

Unspecified Fabricated Tolerance:±3.0

拉弯前展开长度: 4945.42 mm

外弧长度: 5000 mm

SIGNATURE GRADEING	HIGH SIGNATURE GRADEING	C.C.DIA(MM)	Ø55.9						
AREA (SQ MM)	216	UNSPECIFIED THICKNESS	3±0.15	PERIMETER (MM)	150	STANDARD	BS EN755	SCALE	1:35
MASS (KG/M)	0.585	UNSPECIFIED CORNERS	R 0.3	SURFACE AREA	100	ALLOY	6063-T6	VERSION	B
		DRAWN	陈晓舒	DATE	2019-04-12	APPELLATION	-	PAGE OF	
		STANDARDIZATION		DATE		 <b>PANASIA ALUMINUM (CHINA) LIMITED</b>			
		TO SIGN	陈国提	DATE					
		AUDITING		DATE					
MARKER	MODIFY	FILE NO	SIGNATURE	DATE	APPROV	DATE			

CUSTOMER	HONGKONG CO.	CUSTOMER APPROVAL	CUST PART NO.	J837-WH-17
			SECTION NO.	PE00E3465(F07)

此面为外圆

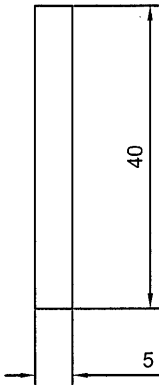

SECTION A-A

此面为内圆

SCALE 1:1

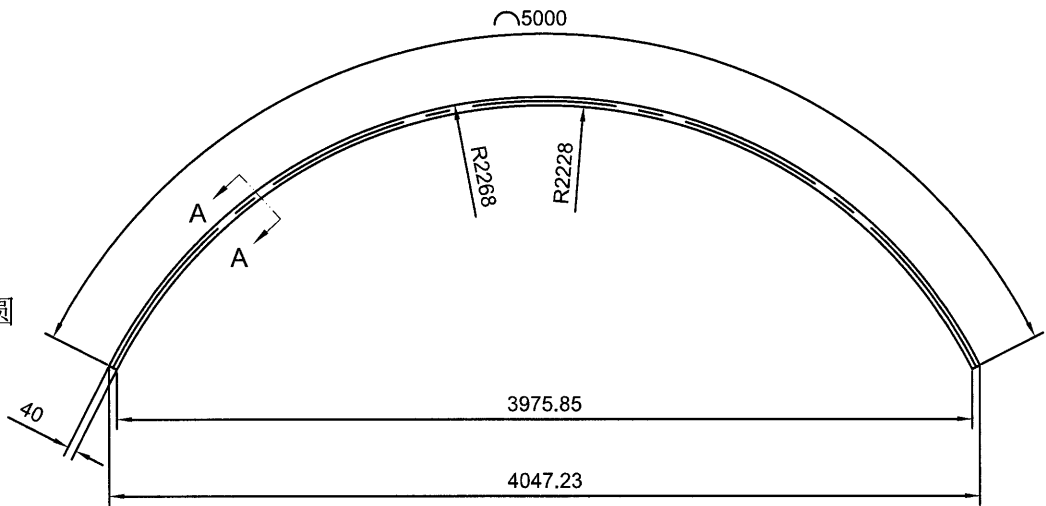

美特铝质有限公司	
承认图面	<i>[Signature]</i>
日期	30/4-2019

技术要求:

- 1.平面度偏差0~1.0mm;
- 2.扭拧度偏差0~5.0mm;
- 3.角度变形±1.5°;
- 4.产品未注公差±3.0mm;
- 5.允许两端各预留10mm钳口位。

Total weight:2.686 kg/pcs

Unspecified Fabricated Tolerance:±3.0

拉弯前展开长度: 4955.91 mm

外弧长度: 5000 mm

SIGNATURE GRADEING	HIGH SIGNATURE GRADEING	C.C.DIA(MM)	Ø40.31						
AREA (SQ MM)	200	UNSPECIFIED THICKNESS	-	PERIMETER (MM)	90	STANDARD	BS EN755	SCALE	1:35
MASS (KG/M)	0.542	UNSPECIFIED CORNERS	-	SURFACE AREA	-	ALLOY	6063-T6	VERSION	B
		DRAWN		陈晓舒	DATE	2019-04-12	APPELLATION	-	
		STANDARDIZATION			DATE				
		TO SIGN		陈国提	DATE				
		AUDITING			DATE				
MARKER	MODIFY	FILE NO	SIGNATURE	DATE	APPROV	DATE			



CUSTOMER	HONGKONG CO.	CUSTOMER APPROVAL	CUST PART NO.	J837-WH-18
			SECTION NO.	LH0090289(F08)

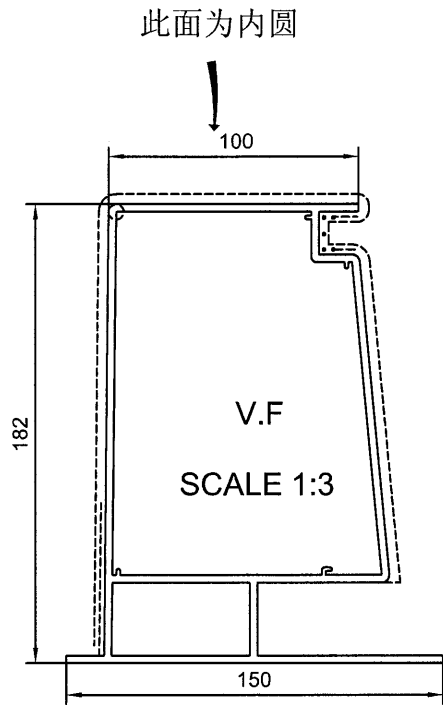

美特铝质有限公司	
承認圖面	<i>[Signature]</i>
日期	30/4-2019

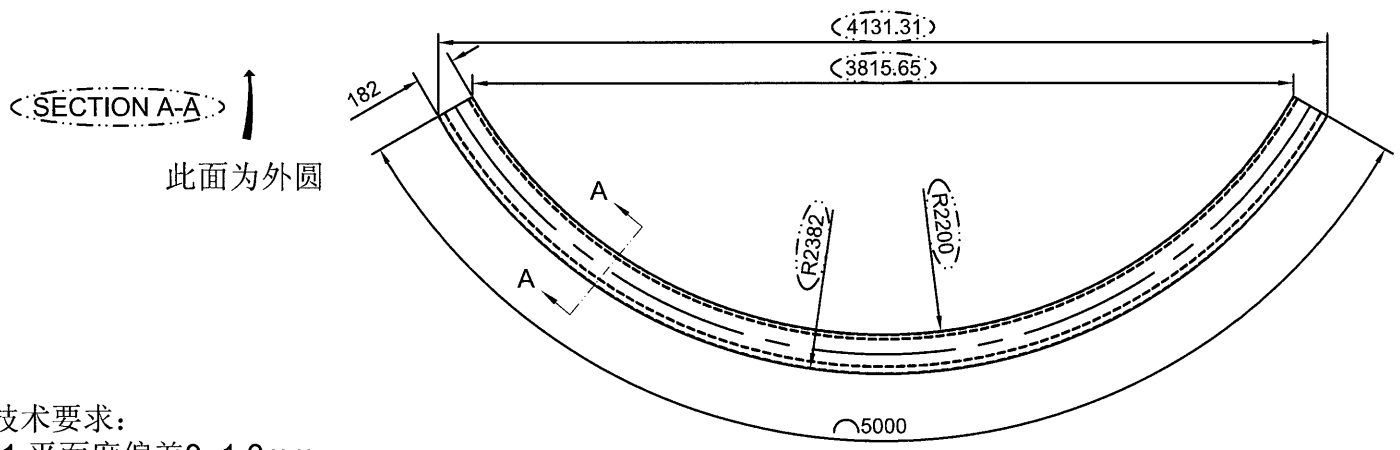

技术要求:

1. 平面度偏差0~1.0mm;
2. 扭拧度偏差0~5.0mm;
3. 角度变形±1.5°;
4. 产品未注公差±3.0mm;
5. 允许两端各预留10mm钳口位。

Total weight: 28.580kg/pcs  
 Unspecified Fabricated Tolerance: ±3.0

拉弯前展开长度: 4808.99mm  
 外弧长度: 5000mm

SIGNATURE GRADEING	HIGH SIGNATURE GRADEING	C.C.DIA(MM)	Ø225.3						
AREA (SQ MM)	2193.12	UNSPECIFIED THICKNESS	3±0.25	PERIMETER (MM)	782.82	STANDARD	BS EN755	SCALE	1:35
MASS (KG/M)	5.943	UNSPECIFIED CORNERS	R 0.3	SURFACE AREA	460.12	ALLOY	6063-T6	VERSION	B
		DRAWN	陈晓舒	DATE	2019-04-12	APPELLATION	-	PAGE OF	
		STANDARDIZATION		DATE					
		TO SIGN	陈国提	DATE					
		AUDITING		DATE					
MARKER	MODIFY	FILE NO	SIGNATURE	DATE	APPROV	DATE			

CUSTOMER	HONGKONG CO.	CUSTOMER APPROVAL	CUST PART NO.	J837-WH-19
			SECTION NO.	LH0090290(F08)

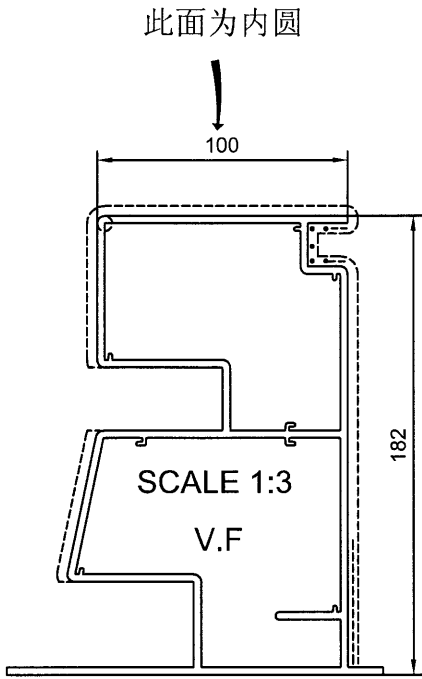

美特铝质有限公司	
承認圖面	<i>[Signature]</i>
日期	30/4-2019

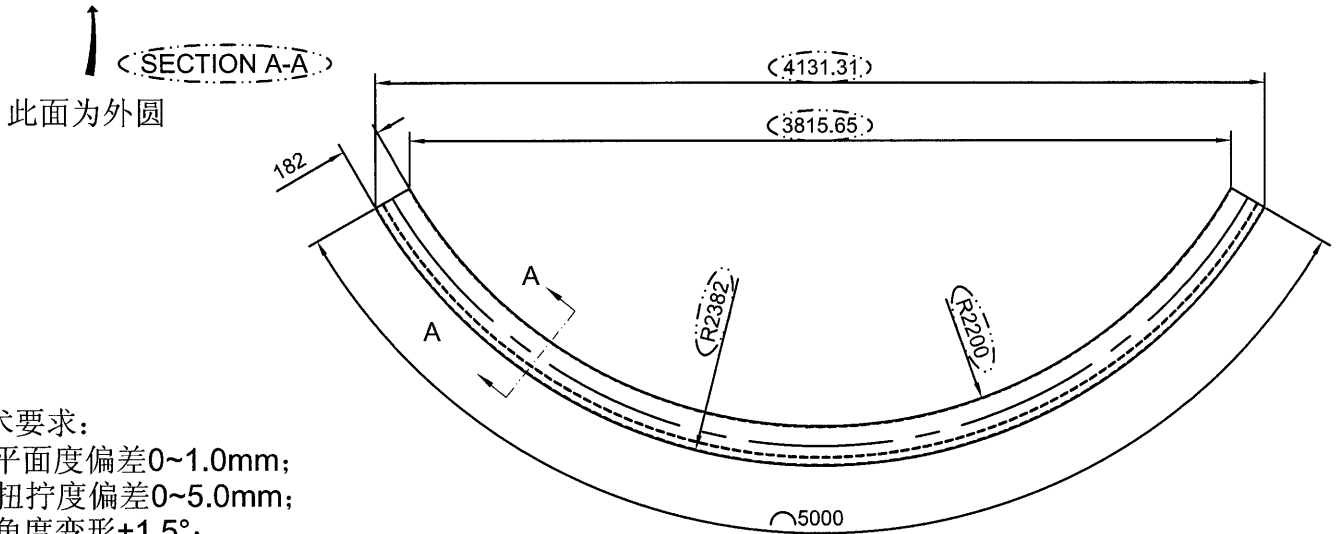

- 技术要求:
- 1.平面度偏差0~1.0mm;
  - 2.扭拧度偏差0~5.0mm;
  - 3.角度变形±1.5°;
  - 4.产品未注公差±3.0mm;
  - 5.允许两端各预留10mm钳口位。
- Total weight: 33.168kg/pcs  
 Unspecified Fabricated Tolerance: ±3.0

拉弯前展开长度: 4808.99mm  
 外弧长度: 5000 mm

SIGNATURE GRADEING	HIGH SIGNATURE GRADEING	C.C.DIA(MM)	Ø227.56						
AREA (SQ MM)	2545.02	UNSPECIFIED THICKNESS	3±0.25	PERIMETER (MM)	878.28	STANDARD	BS EN755	SCALE	1:35
MASS (KG/M)	6.897	UNSPECIFIED CORNERS	R 0.3	SURFACE AREA	434.22	ALLOY	6063-T6	VERSION	B
		DRAWN	陈晓舒	DATE	2019-04-12	APPELLATION	-	PAGE OF	
		STANDARDIZATION		DATE					
		TO SIGN	陈国提	DATE					
		AUDITING		DATE					
MARKER	MODIFY	FILE NO	SIGNATURE	DATE	APPROV	DATE			



CUSTOMER	HONGKONG CO.	CUSTOMER APPROVAL	CUST PART NO.	J837-WH-20
			SECTION NO.	LH0090166(F03)

此面为内圆

美特铝业有限公司	
承認圖面	仲
日期	30/4-2019

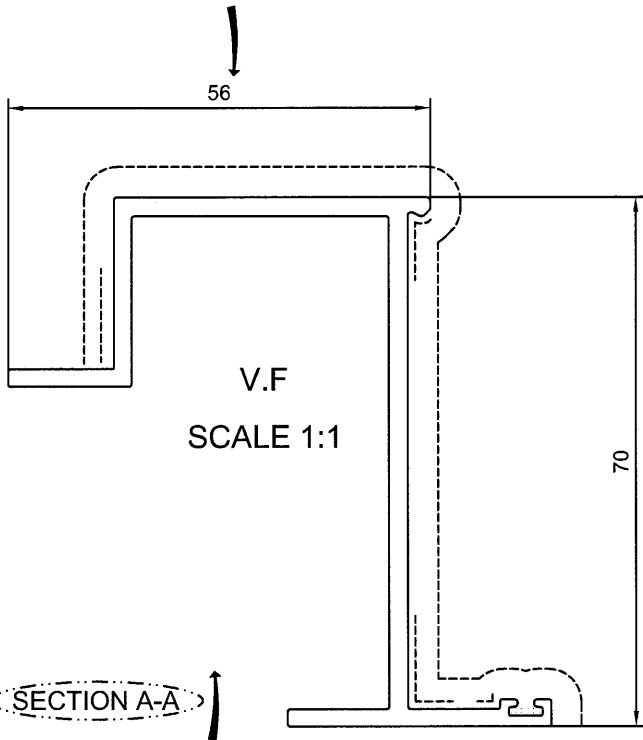

此面为外圆

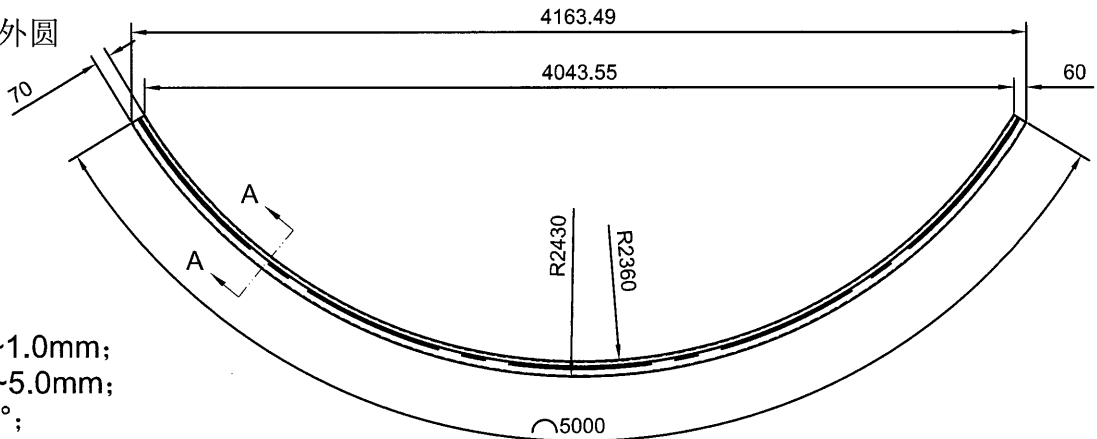

技术要求:

1. 平面度偏差0~1.0mm;
2. 扭拧度偏差0~5.0mm;
3. 角度变形±1.5°;
4. 产品未注公差±3.0mm;
5. 允许两端各预留10mm钳口位。

Total weight: 5.776 kg/pcs

Unspecified Fabricated Tolerance:±3.0

拉弯前展开长度: 4927.99 mm

外弧长度: 5000 mm

SIGNATURE GRADEING	HIGH SIGNATURE GRADEING	C.C.DIA(MM)	Ø93.07						
AREA (SQ MM)	432.6	UNSPECIFIED THICKNESS	2.3±0.2	PERIMETER (MM)	370.19	STANDARD	BS EN755	SCALE	1:35
MASS (KG/M)	1.172	UNSPECIFIED CORNERS	R 0.3	SURFACE AREA	166.52	ALLOY	6063-T6	VERSION	B
		DRAWN	陈晓舒	DATE	2019-04-12	APPELLATION	-	PAGE OF	
		STANDARDIZATION		DATE					
		TO SIGN	陈国提	DATE					
		AUDITING		DATE					
MARKER	MODIFY	FILE NO	SIGNATURE	DATE	APPROV	DATE			

CUSTOMER	HONGKONG CO.	CUSTOMER APPROVAL	CUST PART NO.	J837-WH-21
			SECTION NO.	LH0090165(F03)

此面为内圆

美特铝质有限公司	
承認圖面	<i>[Signature]</i>
日期	30/4-2019

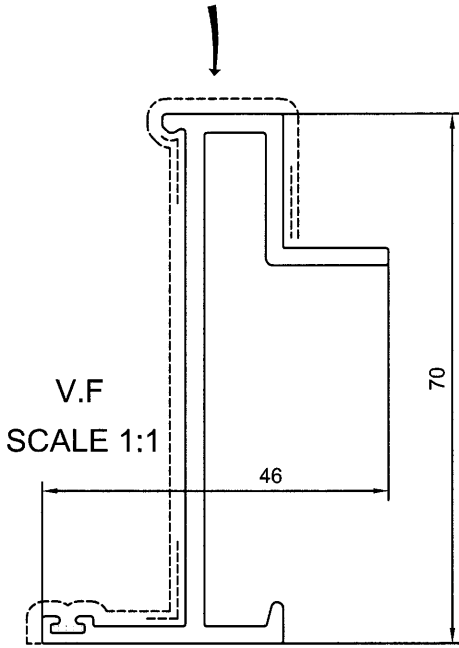

SECTION A-A

此面为外圆

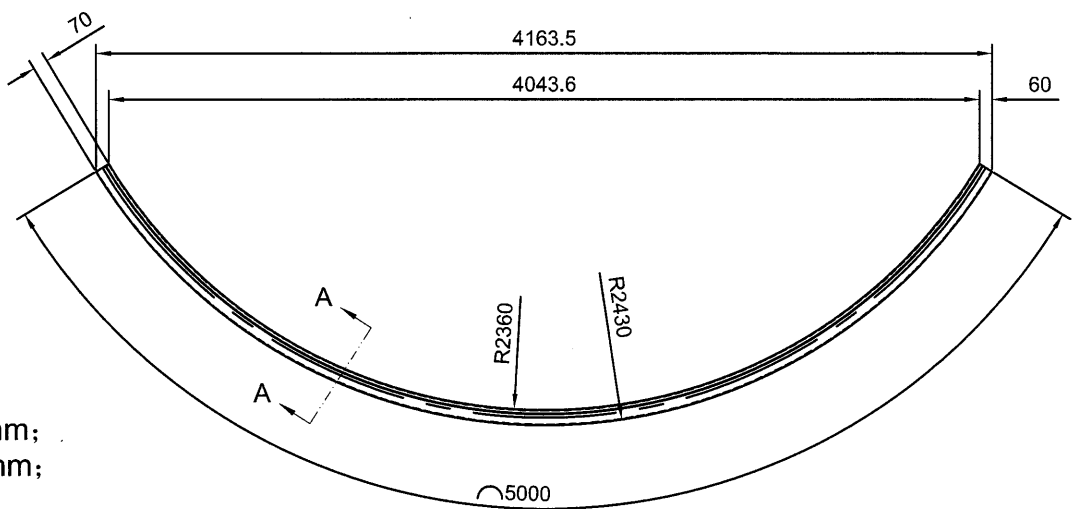

技术要求:

- 1. 平面度偏差0~1.0mm;
- 2. 扭拧度偏差0~5.0mm;
- 3. 角度变形±1.5°;
- 4. 产品未注公差±3.0mm;
- 5. 允许两端各预留10mm钳口位。

Total weight: 4.736 kg/pcs

Unspecified Fabricated Tolerance:±3.0

拉弯前展开长度: 4927.99 mm

外弧长度: 5000 mm

SIGNATURE GRADEING	HIGH SIGNATURE GRADEING	C.C.DIA(MM)	Ø76.78						
AREA (SQ MM)	354.71	UNSPECIFIED THICKNESS	2.3±0.2	PERIMETER (MM)	307.08	STANDARD	BS EN755	SCALE	1:35
MASS (KG/M)	0.961	UNSPECIFIED CORNERS	R 0.3	SURFACE AREA	135.52	ALLOY	6063-T6	VERSION	B
		DRAWN	陈晓舒	DATE	2019-04-12	APELLATION	-	PAGE OF	
		STANDARDIZATION		DATE					
		TO SIGN	陈国提	DATE					
		AUDITING		DATE					
MARKER	MODIFY	FILE NO	SIGNATURE	DATE	APPROV				



CUSTOMER	HONGKONG CO.	CUSTOMER APPROVAL	CUST PART NO.	J837-WH-22
			SECTION NO.	LH0090167(F03)

此面为内圆

美特铝质有限公司	
承認圖面	
日期	30/4-2019

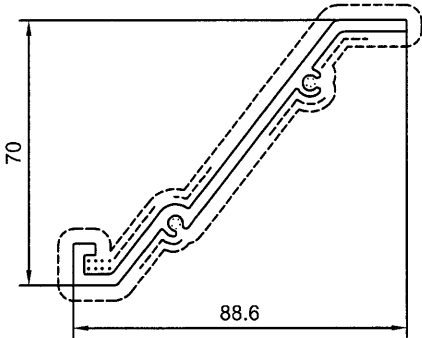

V.F

SCALE 1:2

SECTION A-A

此面为外圆

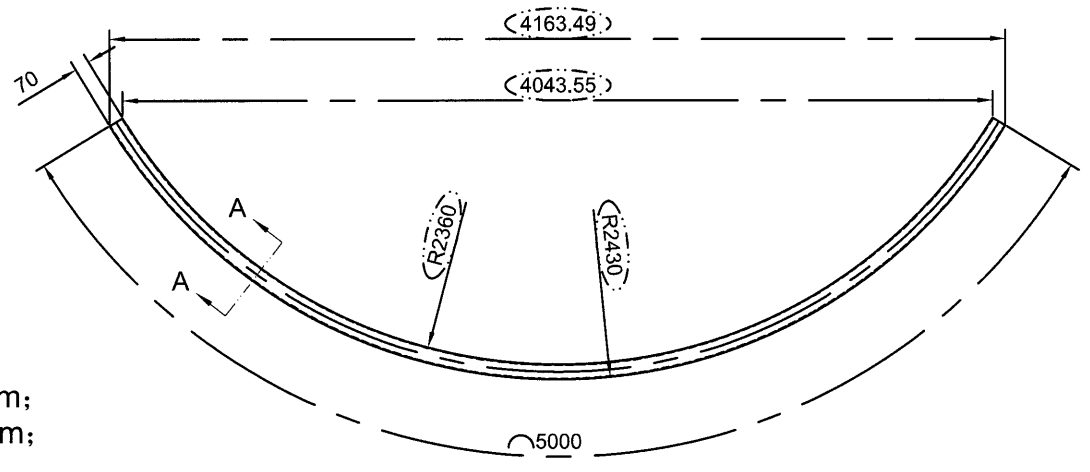

技术要求:

- 1.平面度偏差0~1.0mm;
- 2.扭拧度偏差0~5.0mm;
- 3.角度变形±1.5°;
- 4.产品未注公差±3.0mm;
- 5.允许两端各预留10mm钳口位。

Total weight: 5.697kg/pcs

Unspecified Fabricated Tolerance: ±3.0

拉弯前展开长度: 4927.99mm

外弧长度: 5000 mm

SIGNATURE GRADEING	HIGH SIGNATURE GRADEING	C.C.DIA(MM)	Ø135.52						
AREA (SQ MM)	426.67	UNSPECIFIED THICKNESS	3±0.25	PERIMETER (MM)	296.71	STANDARD	BS EN755	SCALE	1:35
MASS (KG/M)	1.156	UNSPECIFIED CORNERS	R 0.3	SURFACE AREA	296.71	ALLOY	6063-T6	VERSION	B
		DRAWN	陈晓舒	DATE	2019-04-12	APPELLATION	-	PAGE OF	
		STANDARDIZATION		DATE					
		TO SIGN	陈国提	DATE					
		AUDITING		DATE					
MARKER	MODIFY	FILE NO	SIGNATURE	DATE	APPROV	DATE			

CUSTOMER	HONGKONG CO.	CUSTOMER APPROVAL	CUST PART NO.	J837-WH-23
			SECTION NO.	PE0E10027(F11)

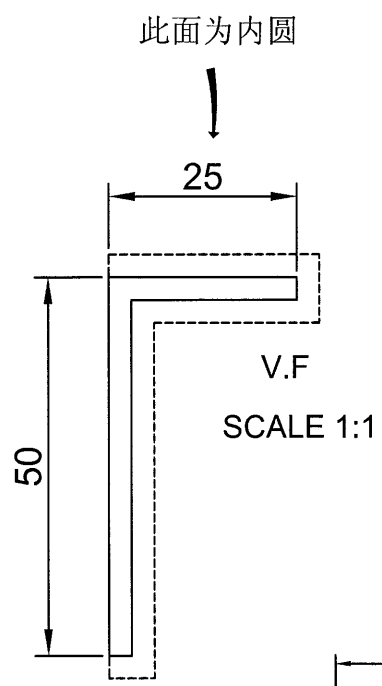

美特铝质有限公司	
承認圖面	印
日期	30/4-2019

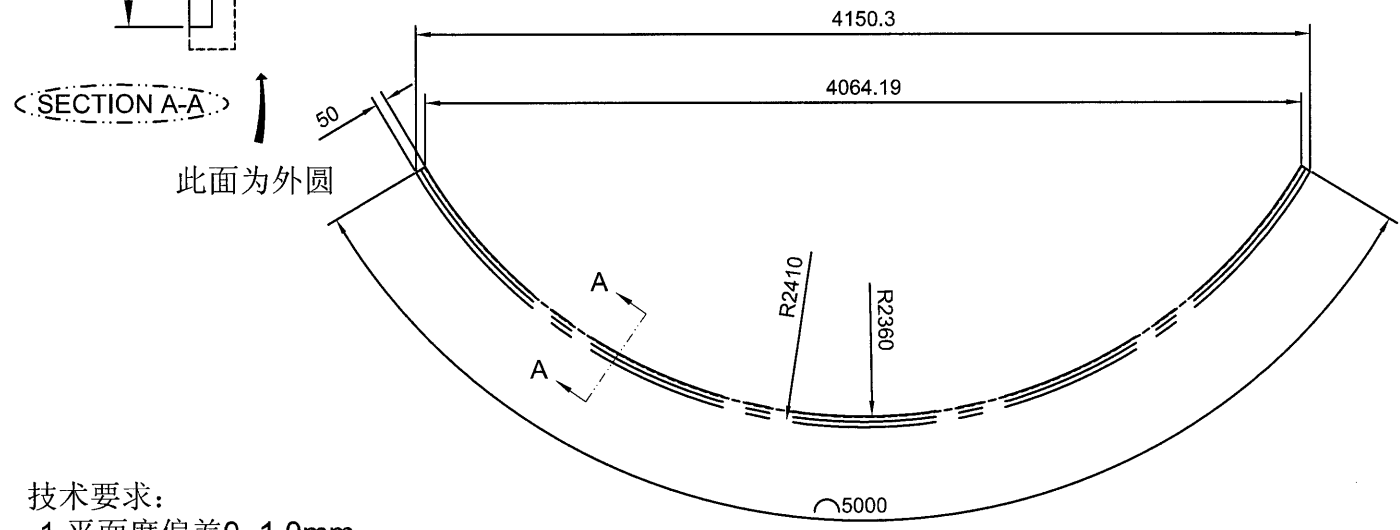

技术要求:

- 1.平面度偏差0~1.0mm;
- 2.扭拧度偏差0~5.0mm;
- 3.角度变形±1.5°;
- 4.产品未注公差±3.0mm;
- 5.允许两端各预留10mm钳口位。

Total weight:2.895 kg/pcs  
Unspecified Fabricated Tolerance:±3.0

拉弯前展开长度: 4948.14 mm  
外弧长度: 5000 mm

SIGNATURE GRADE/ING	HIGH SIGNATURE GRADE/ING	C.C.DIA(MM)	Ø55.9						
AREA (SQ MM)	216	UNSPECIFIED THICKNESS	3±0.15	PERIMETER (MM)	150	STANDARD	BS EN755	SCALE	1:35
MASS (KG/M)	0.585	UNSPECIFIED CORNERS	R 0.3	SURFACE AREA	100	ALLOY	6063-T6	VERSION	B
		DRAWN	陈晓舒	DATE	2019-04-12	APPELLATION	-	PAGE OF	
		STANDARDIZATION		DATE					
		TO SIGN	陈国提	DATE					
		AUDITING		DATE					
MARKER	MODIFY	FILE NO	SIGNATURE	DATE	APPROV				

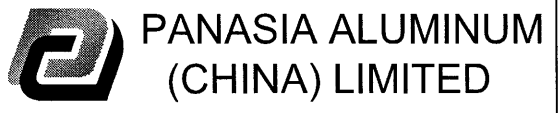

CUSTOMER	HONGKONG CO.	CUSTOMER APPROVAL	CUST PART NO.	J837-WH-24
			SECTION NO.	PE00E3465(F08)

此面为内圆

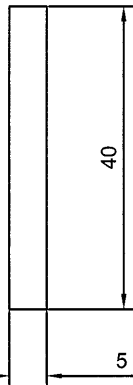

SCALE 1:1

SECTION A-A

此面为外圆

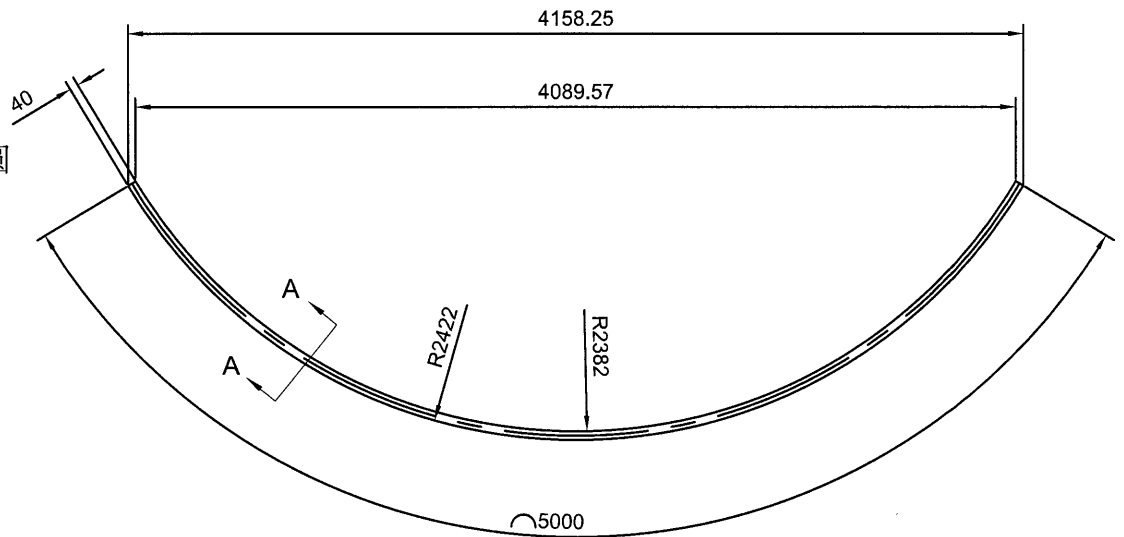

美特铝业有限公司	
承認圖面	
日期	30/4-2019

技术要求:

- 1.平面度偏差0~1.0mm;
- 2.扭拧度偏差0~5.0mm;
- 3.角度变形±1.5°;
- 4.产品未注公差±3.0mm;
- 5.允许两端各预留10mm锚口位。

Total weight:2.688 kg/pcs

Unspecified Fabricated Tolerance:±3.0

拉弯前展开长度: 4958.71 mm

外弧长度: 5000 mm

SIGNATURE GRADEING	HIGH SIGNATURE GRADEING	C.C.DIA(MM)	Ø40.31						
AREA (SQ MM)	200	UNSPECIFIED THICKNESS	-	PERIMETER (MM)	90	STANDARD	BS EN755	SCALE	1:35
MASS (KG/M)	0.542	UNSPECIFIED CORNERS	-	SURFACE AREA	-	ALLOY	6063-T6	VERSION	B
		DRAWN	陈晓舒	DATE	2019-04-12	APPELLATION	-	PAGE OF	
		STANDARDIZATION		DATE					
		TO SIGN	陈国提	DATE					
		AUDITING		DATE					
MARKER	MODIFY	FILE NO	SIGNATURE	DATE	APPROV	DATE			

CUSTOMER	HONGKONG CO.	CUSTOMER APPROVAL	CUST PART NO.	J837-WH-26
			SECTION NO.	LH0090290(F09)

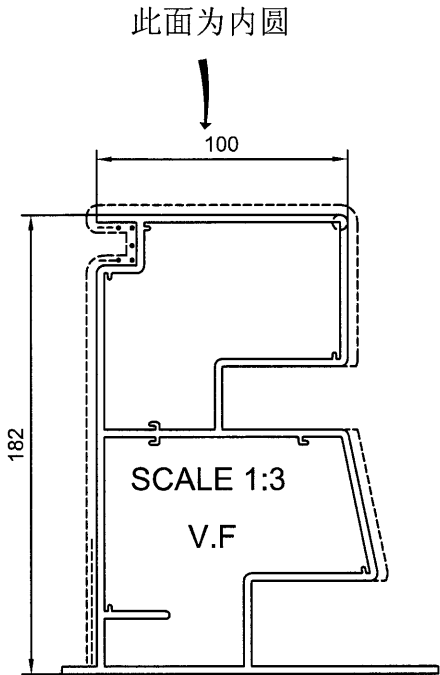

美特铝业有限公司	
承認圖面	<i>[Signature]</i>
日期	70/4-2019

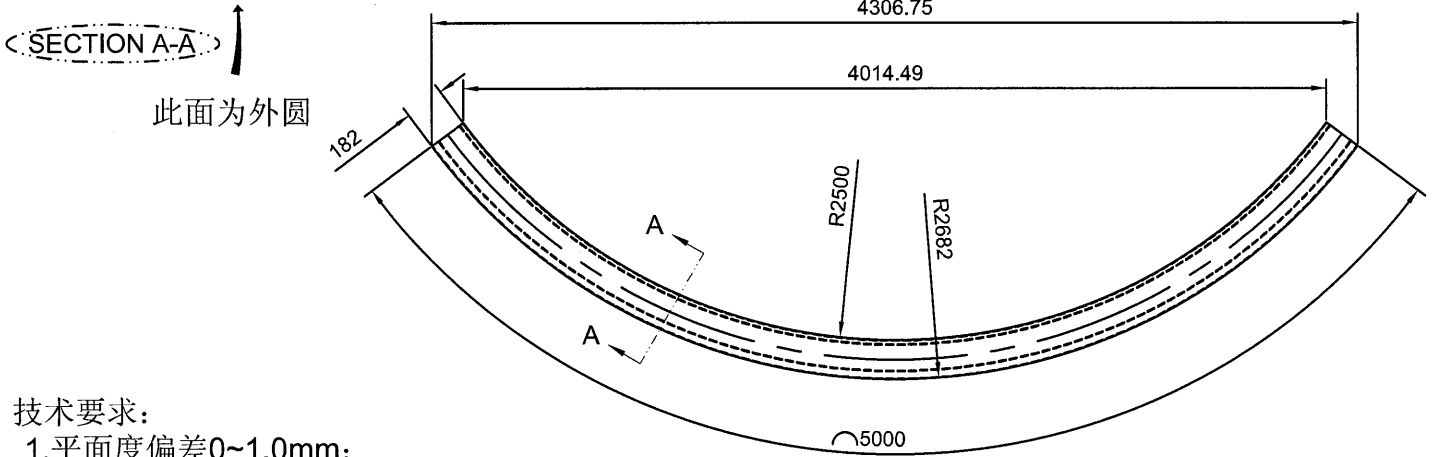

技术要求:

- 1.平面度偏差0~1.0mm;
- 2.扭拧度偏差0~5.0mm;
- 3.角度变形±1.5°;
- 4.产品未注公差±3.0mm;
- 5.允许两端各预留10mm钳口位。

Total weight: 33.315 kg/pcs

Unspecified Fabricated Tolerance:±3.0

拉弯前展开长度: 4830.35 mm

外弧长度: 5000 mm

SIGNATURE GRADEING	HIGH SIGNATURE GRADEING	C.C.DIA(MM)	Ø227.56						
AREA (SQ MM)	2545.02	UNSPECIFIED THICKNESS	3±0.25	PERIMETER (MM)	878.28	STANDARD	BS EN755	SCALE	1:35
MASS (KG/M)	6.897	UNSPECIFIED CORNERS	R 0.3	SURFACE AREA	434.22	ALLOY	6063-T6	VERSION	A
		DRAWN	陈晓舒	DATE	2019-02-28	APPELLATION	-	PAGE OF	
		STANDARDIZATION		DATE					
		TO SIGN	陈国提	DATE					
		AUDITING		DATE					
MARKER	MODIFY	FILE NO	SIGNATURE	DATE	APPROV	DATE			



23

CUSTOMER	HONGKONG CO.	CUSTOMER APPROVAL	CUST PART NO.	J837-WH-27
			SECTION NO.	LH0090166(F04)

此面为内圆

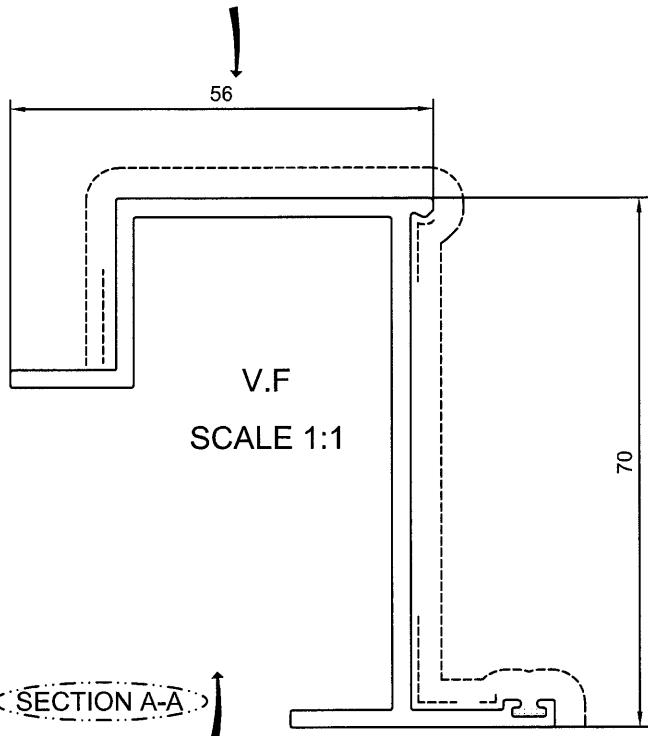

美特铝质有限公司	
承認圖面	<i>[Signature]</i>
日期	30/4-2019

此面为外圆



技术要求:

1. 平面度偏差0~1.0mm;
2. 扭拧度偏差0~5.0mm;
3. 角度变形±1.5°;
4. 产品未注公差±3.0mm;
5. 允许两端各预留10mm钳口位。

Total weight: 5.785 kg/pcs

Unspecified Fabricated Tolerance: ±3.0

拉弯前展开长度: 4935.9 mm

外弧长度: 5000 mm

SIGNATURE GRADEING	HIGH SIGNATURE GRADEING	C.C.DIA(MM)	Ø93.07							
AREA (SQ MM)	432.6	UNSPECIFIED THICKNESS	2.3±0.2	PERIMETER (MM)	370.19	STANDARD	BS EN755	SCALE	1:35	
MASS (KG/M)	1.172	UNSPECIFIED CORNERS	R 0.3	SURFACE AREA	166.52	ALLOY	6063-T6	VERSION	B	
		DRAWN		陈晓舒	DATE	2019-04-12	APPELLATION	-		
		STANDARDIZATION			DATE					
		TO SIGN		陈国提	DATE					
		AUDITING			DATE					
MARKER	MODIFY	FILE NO	SIGNATURE	DATE	APPROV	DATE				



**PANSIA ALUMINUM (CHINA) LIMITED**

CUSTOMER	HONGKONG CO.	CUSTOMER APPROVAL	CUST PART NO.	J837-WH-28
			SECTION NO.	LH0090165(F04)

此面为内圆

美特铝质有限公司	
承認圖面	<i>Handwritten Signature</i>
日期	30/4-2019

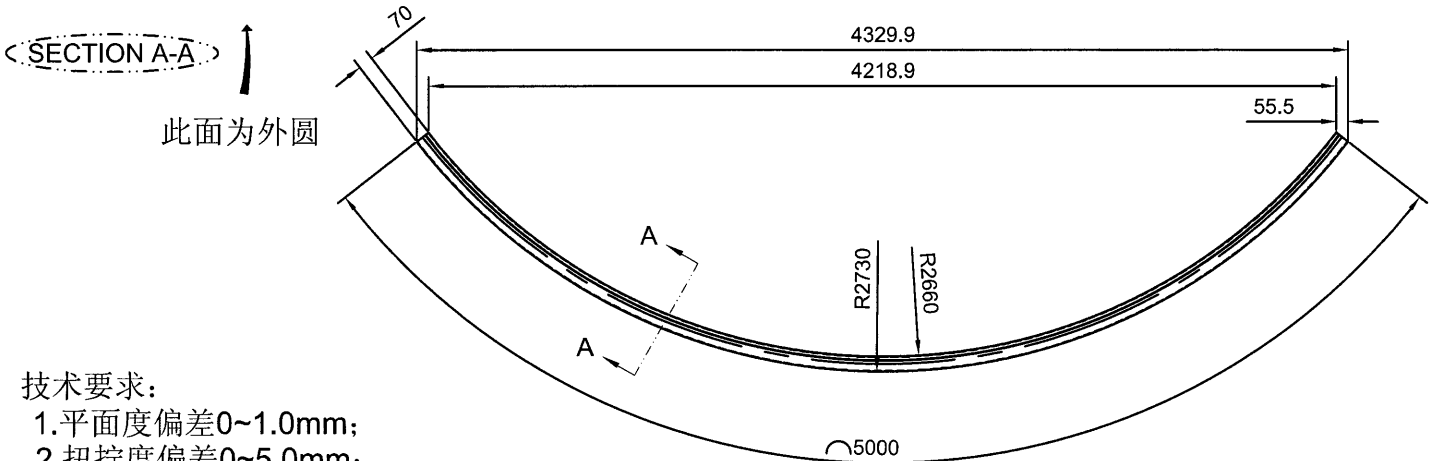
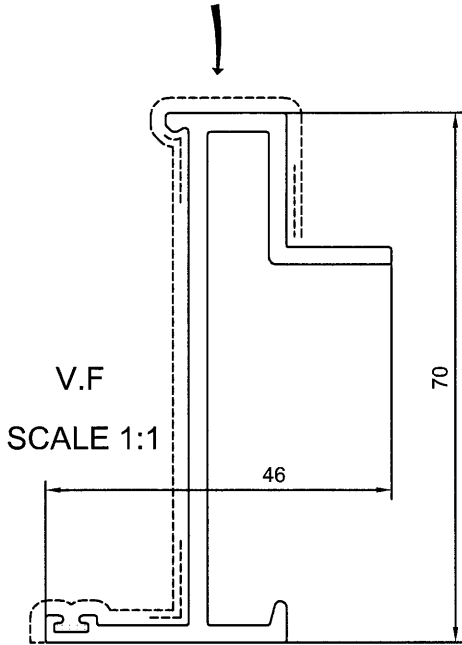

此面为外圆

技术要求:

- 1.平面度偏差0~1.0mm;
- 2.扭拧度偏差0~5.0mm;
- 3.角度变形±1.5°;
- 4.产品未注公差±3.0mm;
- 5.允许两端各预留10mm钳口位。

Total weight: 4.743 kg/pcs

Unspecified Fabricated Tolerance:±3.0

拉弯前展开长度: 4935.9 mm

外弧长度: 5000 mm

SIGNATURE GRADEING	HIGH SIGNATURE GRADEING	C.C.DIA(MM)	Ø76.78						
AREA (SQ MM)	354.71	UNSPECIFIED THICKNESS	2.3±0.2	PERIMETER (MM)	307.08	STANDARD	BS EN755	SCALE	1:35
MASS (KG/M)	0.961	UNSPECIFIED CORNERS	R 0.3	SURFACE AREA	135.52	ALLOY	6063-T6	VERSION	B
		DRAWN	陈晓舒	DATE	2019-04-12	APPELLATION	-	PAGE OF	
		STANDARDIZATION		DATE					
		TO SIGN	陈国提	DATE					
		AUDITING		DATE					
MARKER	MODIFY	FILE NO	SIGNATURE	DATE	APPROV	DATE			



CUSTOMER	HONGKONG CO.	CUSTOMER APPROVAL	CUST PART NO.	J837-WH-29
			SECTION NO.	LH0090167(F04)

美特铝质有限公司	
承認圖面	
日期	30/4-2019

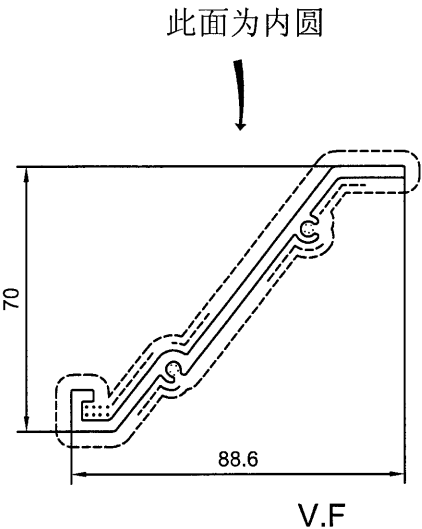

SECTION A-A

SCALE 1:2

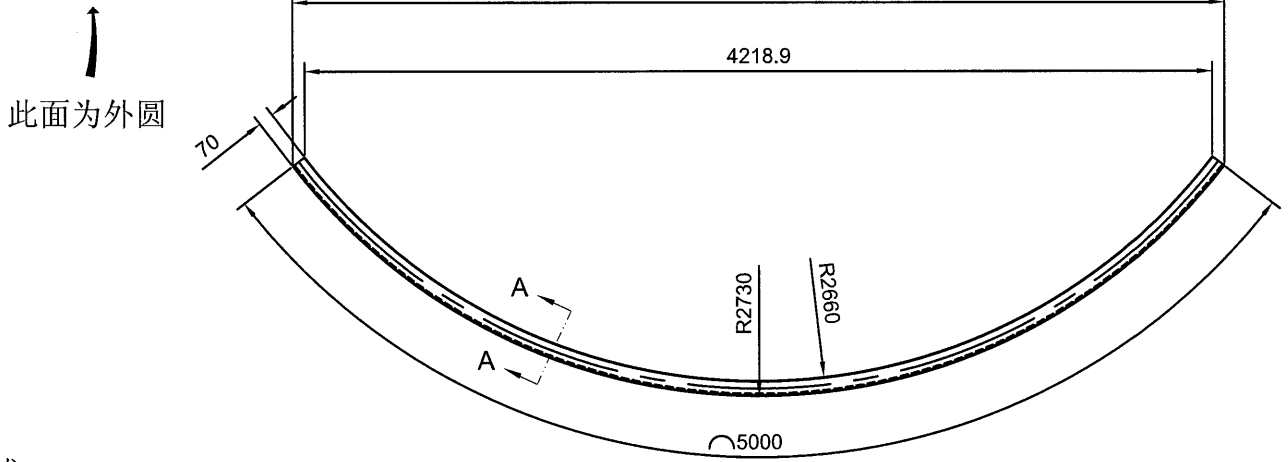

技术要求:

- 1.平面度偏差0~1.0mm;
- 2.扭拧度偏差0~5.0mm;
- 3.角度变形±1.5°;
- 4.产品未注公差±3.0mm;
- 5.允许两端各预留10mm钳口位。

Total weight:5.706 kg/pcs  
Unspecified Fabricated Tolerance:±3.0

拉弯前展开长度: 4935.9 mm  
外弧长度: 5000 mm

SIGNATURE GRADEING	HIGH SIGNATURE GRADEING	C.C.DIA(MM)	Ø135.52						
AREA (SQ MM)	426.67	UNSPECIFIED THICKNESS	3±0.25	PERIMETER (MM)	296.71	STANDARD	BS EN755	SCALE	1:35
MASS (KG/M)	1.156	UNSPECIFIED CORNERS	R 0.3	SURFACE AREA	296.71	ALLOY	6063-T6	VERSION	B
		DRAWN	陈晓舒	DATE	2019-04-12	APPELLATION	-	PAGE OF	
		STANDARDIZATION		DATE					
		TO SIGN	陈国提	DATE					
		AUDITING		DATE					
MARKER	MODIFY	FILE NO	SIGNATURE	DATE	APPROV	DATE			



CUSTOMER	HONGKONG CO.	CUSTOMER APPROVAL	CUST PART NO.	J837-WH-30
			SECTION NO.	PE0E10027(F12)

美特铝业有限公司	
承認圖面	<i>[Signature]</i>
日期	30/4-2019

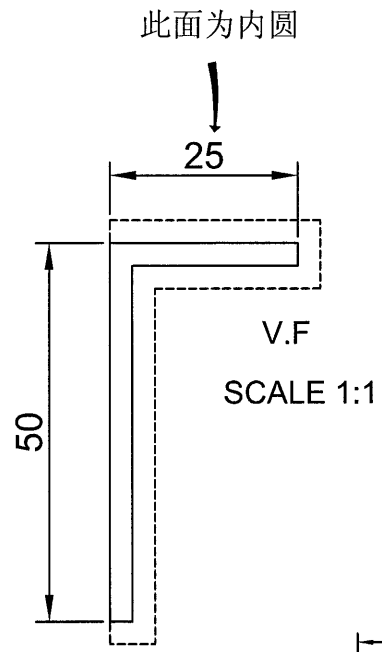

SECTION A-A

此面为外圆

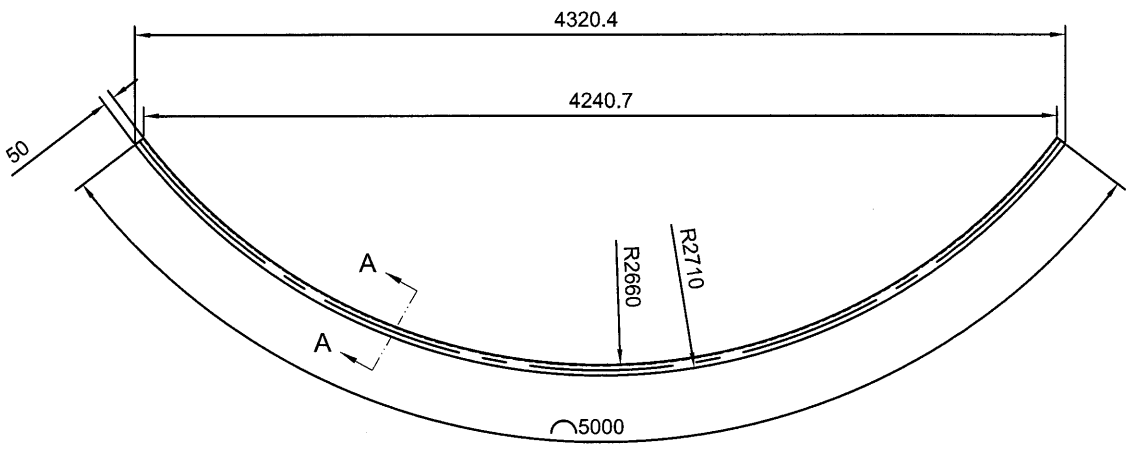

技术要求:

- 1.平面度偏差0~1.0mm;
- 2.扭拧度偏差0~5.0mm;
- 3.角度变形±1.5°;
- 4.产品未注公差±3.0mm;
- 5.允许两端各预留10mm钳口位。

Total weight:2.898 kg/pcs  
Unspecified Fabricated Tolerance:±3.0

拉弯前展开长度: 4953.88 mm  
外弧长度: 5000 mm

SIGNATURE GRADEING	HIGH SIGNATURE GRADEING	C.C.DIA(MM)	Ø55.9								
AREA (SQ MM)	216	UNSPECIFIED THICKNESS	3±0.15	PERIMETER (MM)	150	STANDARD	BS EN755	SCALE	1:35		
MASS (KG/M)	0.585	UNSPECIFIED CORNERS	R 0.3	SURFACE AREA	100	ALLOY	6063-T6	VERSION	B		
		DRAWN	陈晓舒	DATE	2019-04-12	APELLATION	-	PAGE OF			
		STANDARDIZATION		DATE							
		TO SIGN	陈国提	DATE							
		AUDITING		DATE							
MARKER	MODIFY	FILE NO	SIGNATURE	DATE	APPROV	DATE					

CUSTOMER	HONGKONG CO.	CUSTOMER APPROVAL	CUST PART NO.	J837-WH-31
			SECTION NO.	PE00E3465(F09)

美特铝质有限公司	
承認圖面	LP
日期	30/4-2019

此面为内圆

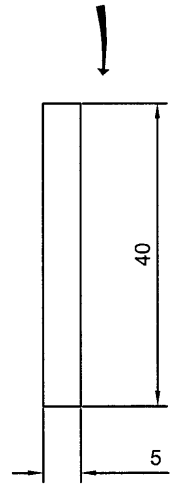

SECTION A-A

此面为外圆

SCALE 1:1

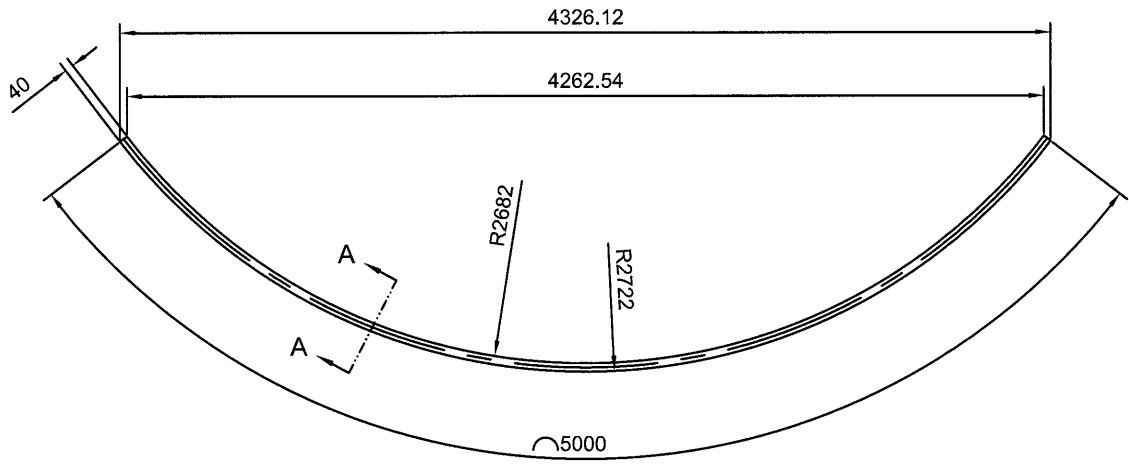

技术要求:

- 1.平面度偏差0~1.0mm;
- 2.扭拧度偏差0~5.0mm;
- 3.角度变形±1.5°;
- 4.产品未注公差±3.0mm;
- 5.允许两端各预留10mm钳口位。

Total weight:2.690 kg/pcs  
Unspecified Fabricated Tolerance:±3.0

拉弯前展开长度: 4963.26 mm  
外弧长度: 5000 mm

SIGNATURE GRADEING	HIGH SIGNATURE GRADEING	C.C.DIA(MM)	Ø40.31								
AREA (SQ MM)	200	UNSPECIFIED THICKNESS	-	PERIMETER (MM)	90	STANDARD	BS EN755	SCALE	1:35		
MASS (KG/M)	0.542	UNSPECIFIED CORNERS	-	SURFACE AREA	-	ALLOY	6063-T6	VERSION	B		
		DRAWN		陈晓舒	DATE	2019-04-12	APPELLATION	-	PAGE OF		
		STANDARDIZATION			DATE						
		TO SIGN		陈国提	DATE						
		AUDITING			DATE						
MARKER	MODIFY	FILE NO	SIGNATURE	DATE	APPROV		DATE				

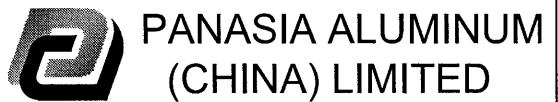

CUSTOMER	HONGKONG CO.	CUSTOMER APPROVAL	CUST PART NO.	J837-WH-32
			SECTION NO.	LH0090289(F10)

美特铝质有限公司	
承認圖面	<i>仲</i>
日期	30/4-2019

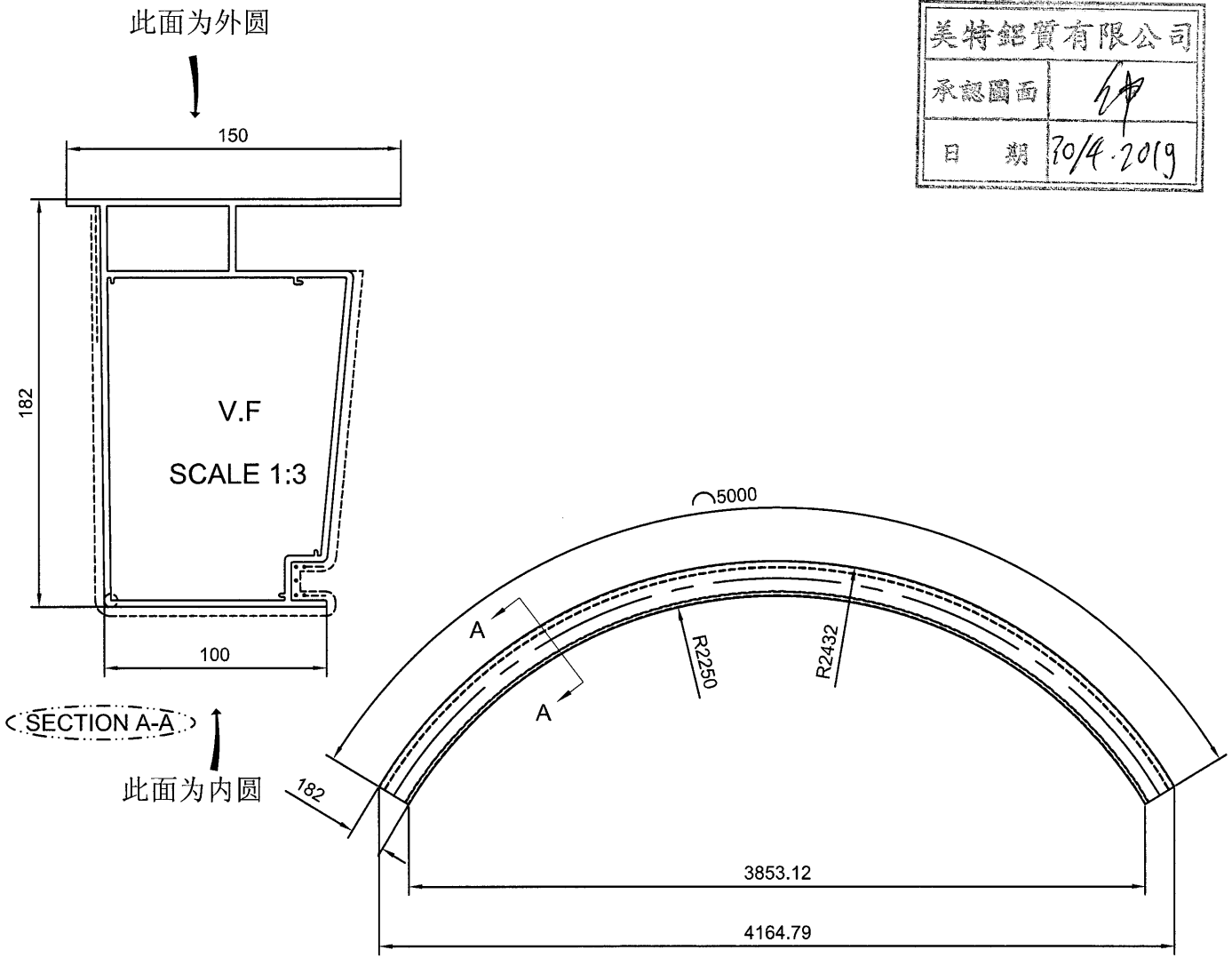

技术要求:

1. 平面度偏差0~1.0mm;
2. 扭拧度偏差0~5.0mm;
3. 角度变形±1.5°;
4. 产品未注公差±3.0mm;
5. 允许两端各预留10mm钳口位。

Total weight: 28.603 kg/pcs

Unspecified Fabricated Tolerance:±3.0

拉弯前展开长度: 4812.91 mm

外弧长度: 5000 mm

SIGNATURE GRADEING	HIGH SIGNATURE GRADEING	C.C.DIA(MM)	Ø225.3							
AREA (SQ MM)	2193.12	UNSPECIFIED THICKNESS	3±0.25	PERIMETER (MM)	782.82	STANDARD	BS EN755	SCALE	1:35	
MASS (KG/M)	5.943	UNSPECIFIED CORNERS	R 0.3	SURFACE AREA	460.12	ALLOY	6063-T6	VERSION	B	
		DRAWN 陈晓舒		DATE	2019-04-12	APPELLATION			PAGE OF	
		STANDARDIZATION		DATE						
		TO SIGN 陈国提		DATE						
		AUDITING		DATE						
MARKER	MODIFY	FILE NO	SIGNATURE	DATE	APPROV					



CUSTOMER	HONGKONG CO.	CUSTOMER APPROVAL	CUST PART NO.	J837-WH-33
			SECTION NO.	LH0090290(F10)

此面为外圆

美特铝质有限公司	
承認圖面	<i>印</i>
日期	30/4-2019

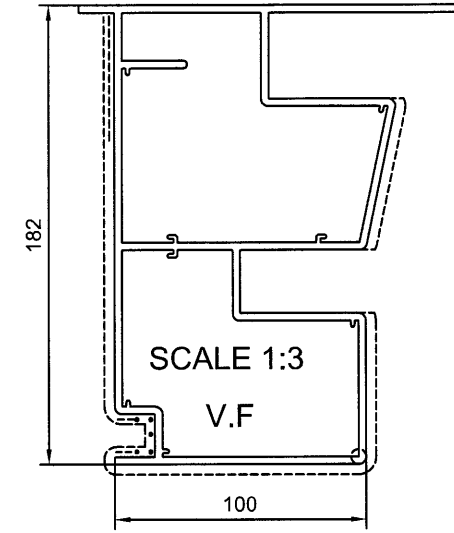

SECTION A-A

此面为内圆

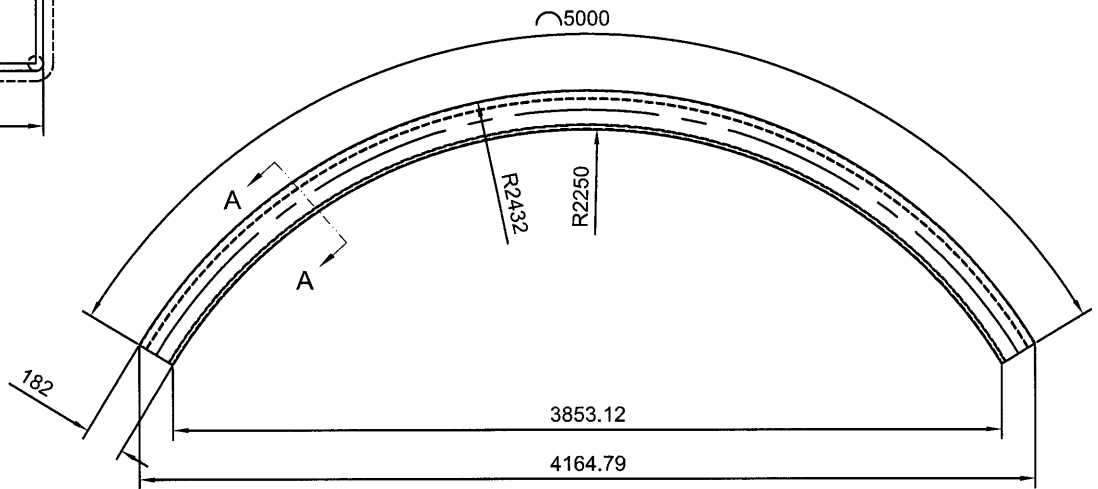

技术要求:

- 1.平面度偏差0~1.0mm;
- 2.扭拧度偏差0~5.0mm;
- 3.角度变形±1.5°;
- 4.产品未注公差±3.0mm;
- 5.允许两端各预留10mm钳口位。

Total weight: 33.195 kg/pcs

Unspecified Fabricated Tolerance:±3.0

拉弯前展开长度: 4812.91 mm

外弧长度: 5000 mm

SIGNATURE GRADEING	HIGH SIGNATURE GRADEING	C.C.DIA(MM)	Ø227.56							
AREA (SQ MM)	2545.02	UNSPECIFIED THICKNESS	3±0.25	PERIMETER (MM)	878.28	STANDARD	BS EN755	SCALE	1:35	
MASS (KG/M)	6.897	UNSPECIFIED CORNERS	R 0.3	SURFACE AREA	434.22	ALLOY	6063-T6	VERSION	B	
		DRAWN 陈晓舒		DATE	2019-04-12	APPELLATION			PAGE OF	
		STANDARDIZATION		DATE						
		TO SIGN 陈国提		DATE						
		AUDITING		DATE						
MARKER	MODIFY	FILE NO	SIGNATURE	DATE	APPROV					



CUSTOMER	HONGKONG CO.	CUSTOMER APPROVAL	CUST PART NO.	J837-WH-34
			SECTION NO.	LH0090166(F05)

此面为外圆

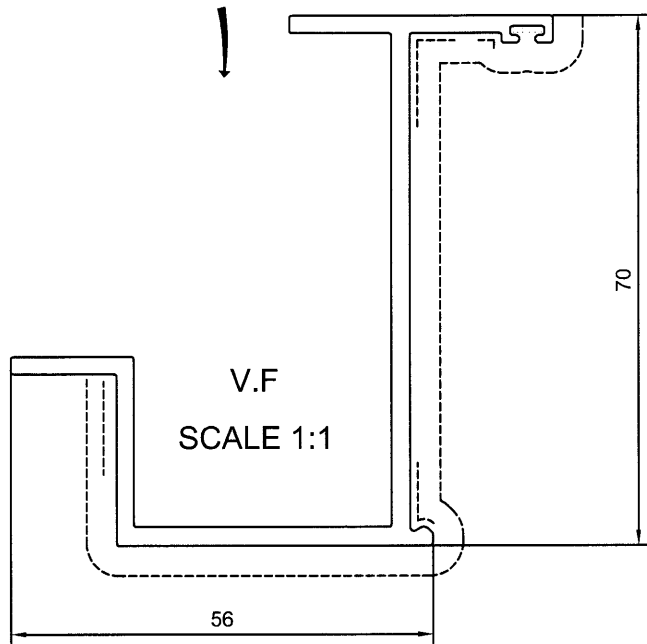

美特铝业有限公司	
承認圖面	印
日期	7/0/4-2019

SECTION A-A

此面为内圆

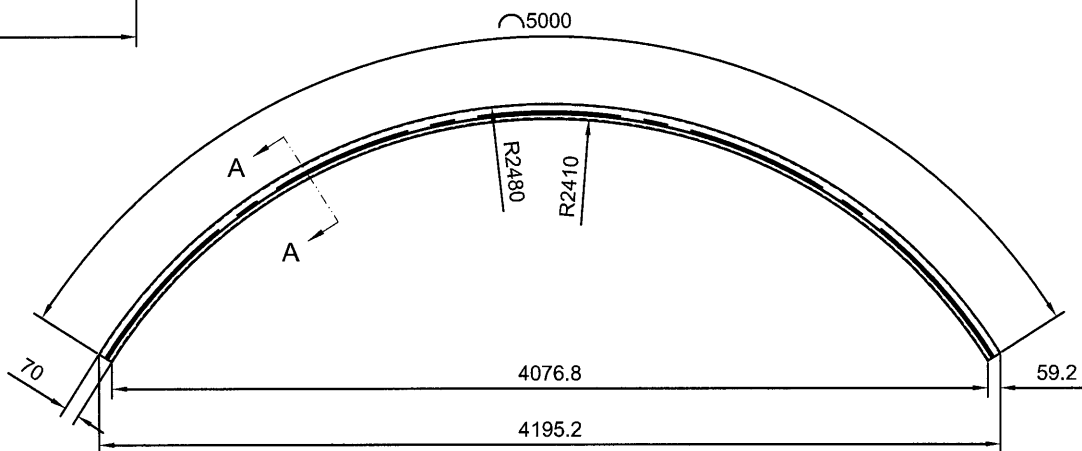

技术要求:

- 1.平面度偏差0~1.0mm;
- 2.扭拧度偏差0~5.0mm;
- 3.角度变形±1.5°;
- 4.产品未注公差±3.0mm;
- 5.允许两端各预留10mm钳口位。

Total weight:5.777 kg/pcs

Unspecified Fabricated Tolerance:±3.0

拉弯前展开长度: 4929.44 mm

外弧长度: 5000 mm

SIGNATURE GRADEING	HIGH SIGNATURE GRADEING	C.C.DIA(MM)	Ø93.07							
AREA (SQ MM)	432.6	UNSPECIFIED THICKNESS	2.3±0.2	PERIMETER (MM)	370.19	STANDARD	BS EN755	SCALE	1:35	
MASS (KG/M)	1.172	UNSPECIFIED CORNERS	R 0.3	SURFACE AREA	166.52	ALLOY	6063-T6	VERSION	B	
-		-		DRAWN	陈晓舒	DATE	2019-04-12	APPELLATION	-	PAGE OF
				STANDARDIZATION		DATE				
				TO SIGN	陈国提	DATE				
				AUDITING		DATE				
MARKER	MODIFY	FILE NO	SIGNATURE	DATE	APPROV	DATE				



CUSTOMER	HONGKONG CO.	CUSTOMER APPROVAL	CUST PART NO.	J837-WH-35
			SECTION NO.	LH0090165(F05)

此面为外圆

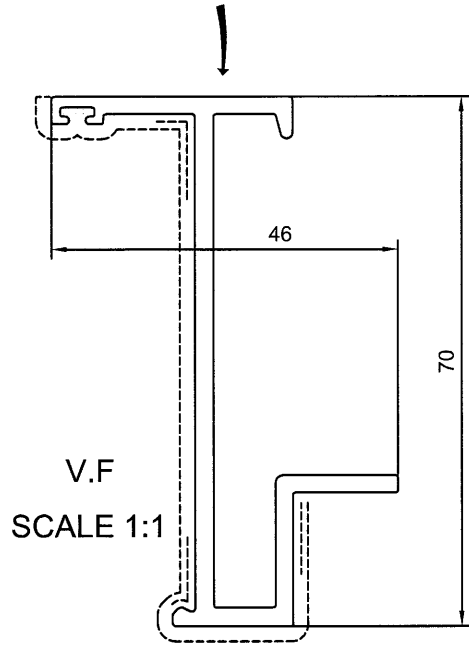

美特铝质有限公司	
承認圖面	<i>EP</i>
日期	20/4-2019

SECTION A-A

此面为内圆

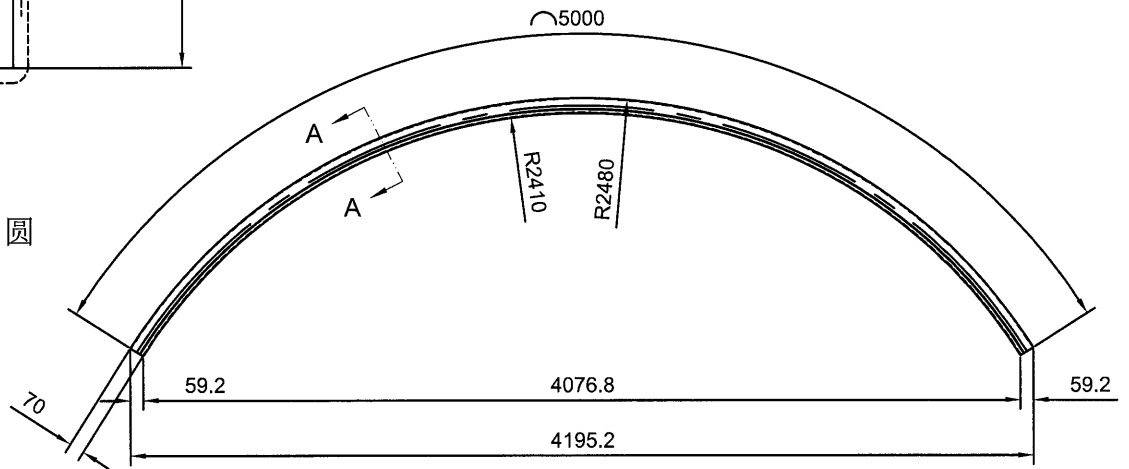

技术要求:

- 1.平面度偏差0~1.0mm;
- 2.扭拧度偏差0~5.0mm;
- 3.角度变形±1.5°;
- 4.产品未注公差±3.0mm;
- 5.允许两端各预留10mm钳口位。

Total weight: 4.737 kg/pcs

Unspecified Fabricated Tolerance:±3.0

拉弯前展开长度: 4929.44 mm

外弧长度: 5000 mm

SIGNATURE GRADEING	HIGH SIGNATURE GRADEING	C.C.DIA(MM)	Ø76.78						
AREA (SQ MM)	354.71	UNSPECIFIED THICKNESS	2.3±0.2	PERIMETER (MM)	307.08	STANDARD	BS EN755	SCALE	1:35
MASS (KG/M)	0.961	UNSPECIFIED CORNERS	R 0.3	SURFACE AREA	135.52	ALLOY	6063-T6	VERSION	B
-	-	DRAWN	陈晓舒	DATE	2019-04-12	APPELLATION	-	PAGE OF	
		STANDARDIZATION		DATE					
		TO SIGN	陈国提	DATE					
		AUDITING		DATE					
MARKER	MODIFY	FILE NO	SIGNATURE	DATE	APPROV				

 PANASIA ALUMINUM (CHINA) LIMITED

32

CUSTOMER	HONGKONG CO.	CUSTOMER APPROVAL	CUST PART NO.	J837-WH-36
			SECTION NO.	LH0090167(F05)

此面为外圆

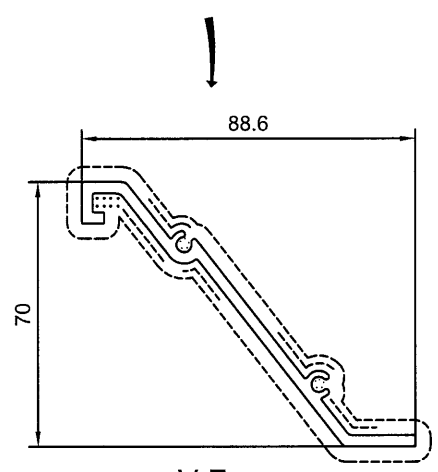

V.F

SCALE 1:2

SECTION A-A

此面为内圆

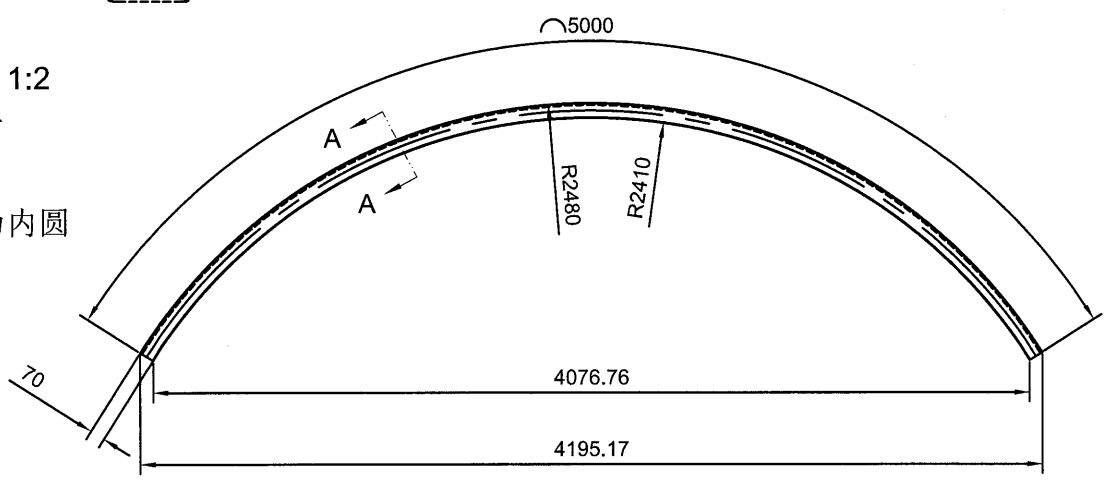

美特鋁質有限公司	
承認圖面	<i>[Signature]</i>
日期	70/4-2019

技术要求:

1. 平面度偏差0~1.0mm;
2. 扭拧度偏差0~5.0mm;
3. 角度变形±1.5°;
4. 产品未注公差±3.0mm;
5. 允许两端各预留10mm钳口位。

Total weight: 5.698 kg/pcs

Unspecified Fabricated Tolerance: ±3.0

拉弯前展开长度: 4929.44 mm

外弧长度: 5000 mm

SIGNATURE GRADE/ING	HIGH SIGNATURE GRADE/ING	C.C.DIA(MM)	Ø135.52						
AREA (SQ MM)	426.67	UNSPECIFIED THICKNESS	3±0.25	PERIMETER (MM)	296.71	STANDARD	BS EN755	SCALE	1:35
MASS (KG/M)	1.156	UNSPECIFIED CORNERS	R 0.3	SURFACE AREA	296.71	ALLOY	6063-T6	VERSION	B
		DRAWN	陈晓舒	DATE	2019-04-12	APPELLATION	-	PAGE OF	
		STANDARDIZATION		DATE					
		TO SIGN	陈国提	DATE					
		AUDITING		DATE					
MARKER	MODIFY	FILE NO	SIGNATURE	DATE	APPROV				



PANASIA ALUMINUM (CHINA) LIMITED

CUSTOMER	HONGKONG CO.	CUSTOMER APPROVAL	CUST PART NO.	J837-WH-37
			SECTION NO.	PE0E10027(F13)

美特鋁質有限公司	
承認圖面	
日期	30/4-2019

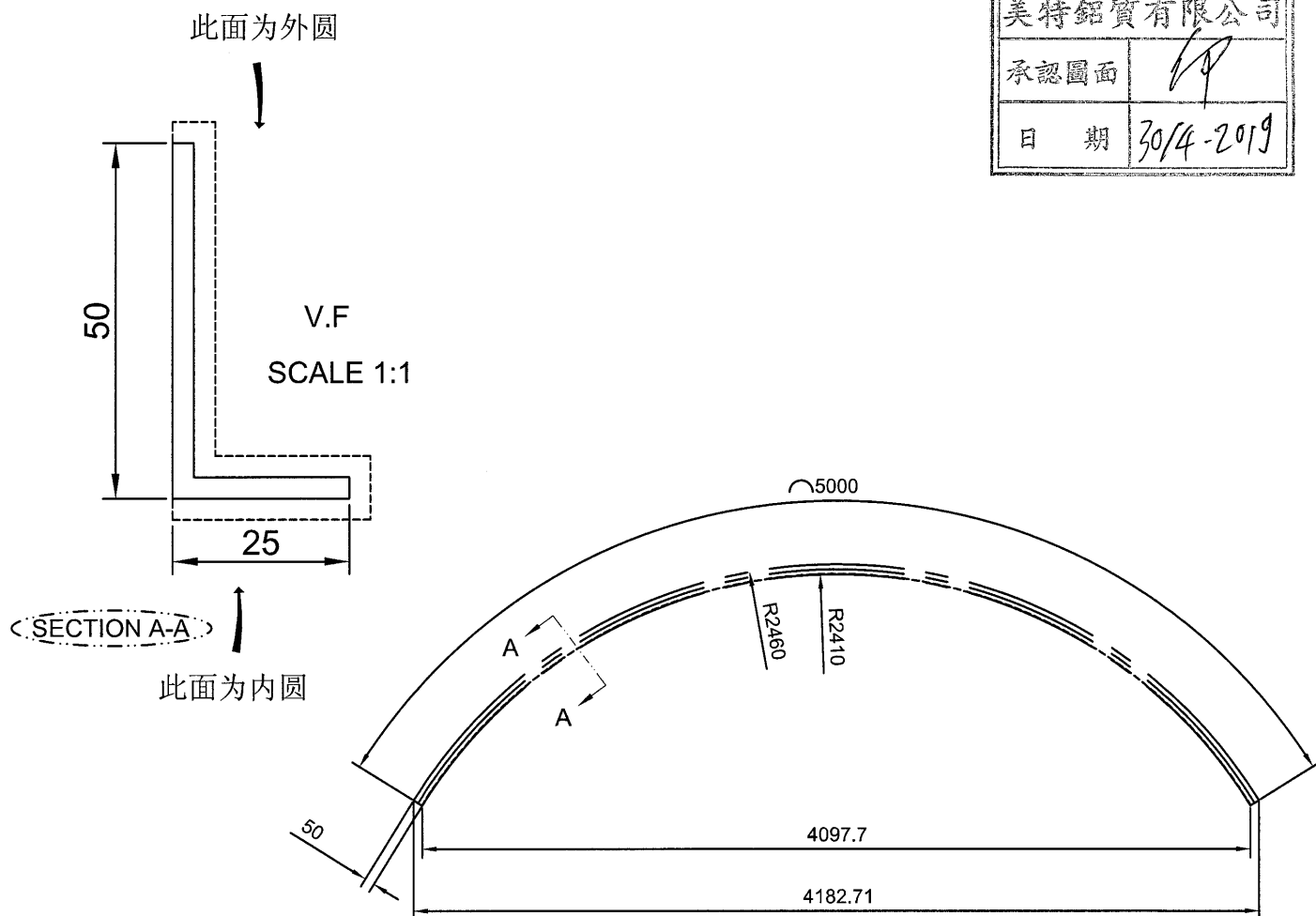

技术要求:

- 1.平面度偏差0~1.0mm;
- 2.扭拧度偏差0~5.0mm;
- 3.角度变形±1.5°;
- 4.产品未注公差±3.0mm;
- 5.允许两端各预留10mm钳口位。

Total weight:2.895 kg/pcs

Unspecified Fabricated Tolerance:±3.0

拉弯前展开长度: 4949.19 mm

外弧长度: 5000 mm

SIGNATURE GRADEING	HIGH SIGNATURE GRADEING	C.C.DIA(MM)	Ø55.9						
AREA (SQ MM)	216	UNSPECIFIED THICKNESS	3±0.15	PERIMETER (MM)	150	STANDARD	BS EN755	SCALE	1:35
MASS (KG/M)	0.585	UNSPECIFIED CORNERS	R 0.3	SURFACE AREA	100	ALLOY	6063-T6	VERSION	B
		DRAWN	陈晓舒	DATE	2019-04-12	APPELLATION	-	PAGE OF	
		STANDARDIZATION		DATE					
		TO SIGN	陈国提	DATE					
		AUDITING		DATE					
MARKER	MODIFY	FILE NO	SIGNATURE	DATE	APPROV				



CUSTOMER	HONGKONG CO.	CUSTOMER APPROVAL	CUST PART NO.	J837-WH-38
			SECTION NO.	PE00E3465(F10)

美特铝质有限公司	
承認圖面	
日期	30/4-2019

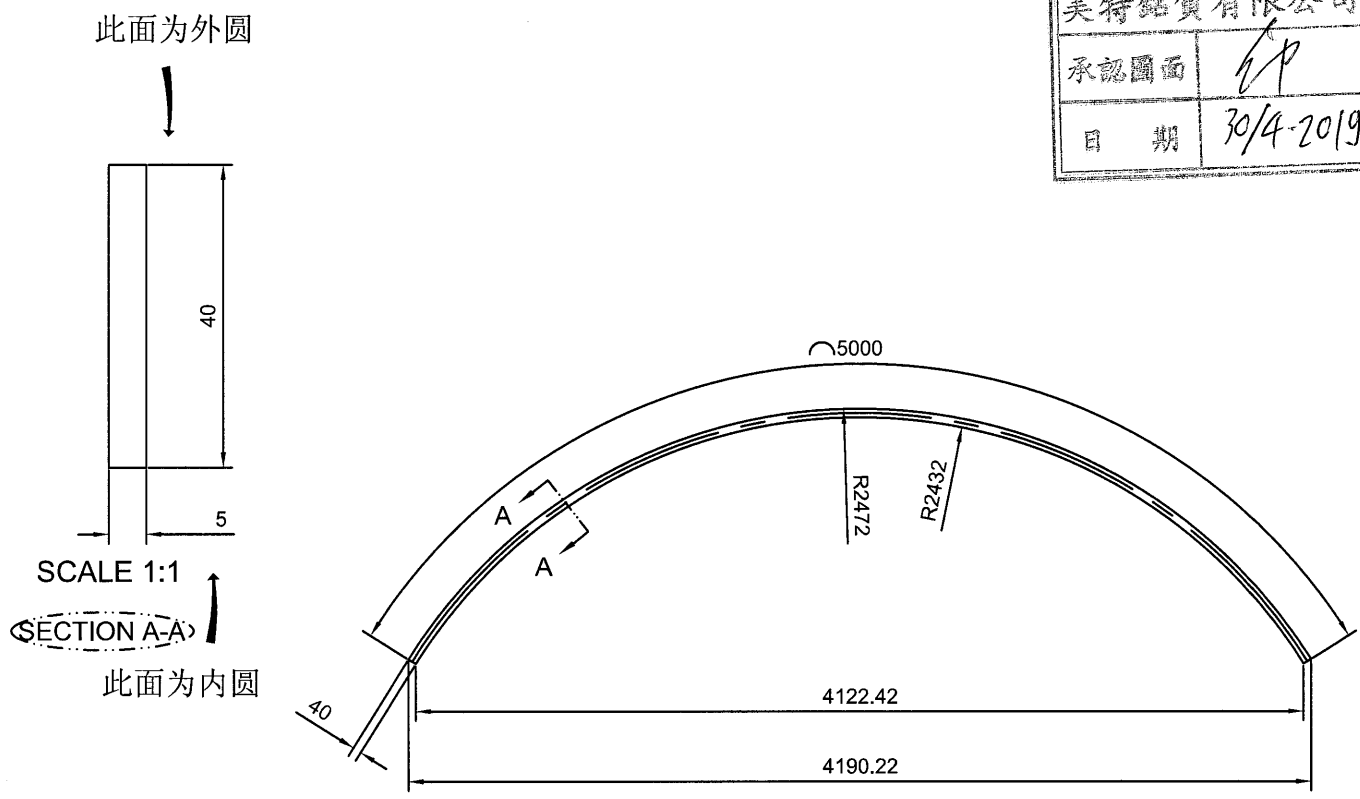

技术要求:

- 1. 平面度偏差0~1.0mm;
- 2. 扭拧度偏差0~5.0mm;
- 3. 角度变形±1.5°;
- 4. 产品未注公差±3.0mm;
- 5. 允许两端各预留10mm锚口位。

Total weight: 2.688 kg/pcs  
 Unspecified Fabricated Tolerance: ±3.0

拉弯前展开长度: 4959.55 mm  
 外弧长度: 5000 mm

SIGNATURE GRADEING	HIGH SIGNATURE GRADEING	C.C.DIA(MM)	Ø40.31						
AREA (SQ MM)	200	UNSPECIFIED THICKNESS	-	PERIMETER (MM)	90	STANDARD	BS EN755	SCALE	1:35
MASS (KG/M)	0.542	UNSPECIFIED CORNERS	-	SURFACE AREA	-	ALLOY	6063-T6	VERSION	B
		DRAWN		陈晓舒	DATE	2019-04-12	APPELLATION		-
		STANDARDIZATION			DATE		PAGE OF		
		TO SIGN		陈国提	DATE				
		AUDITING			DATE				
MARKER	MODIFY	FILE NO	SIGNATURE	DATE	APPROV		DATE		

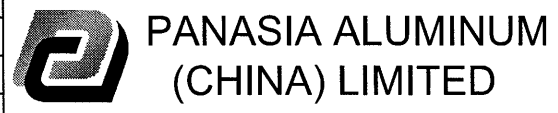

CUSTOMER	HONGKONG CO.	CUSTOMER APPROVAL	CUST PART NO.	J837-WH-06
			SECTION NO.	LH0090166(F01)

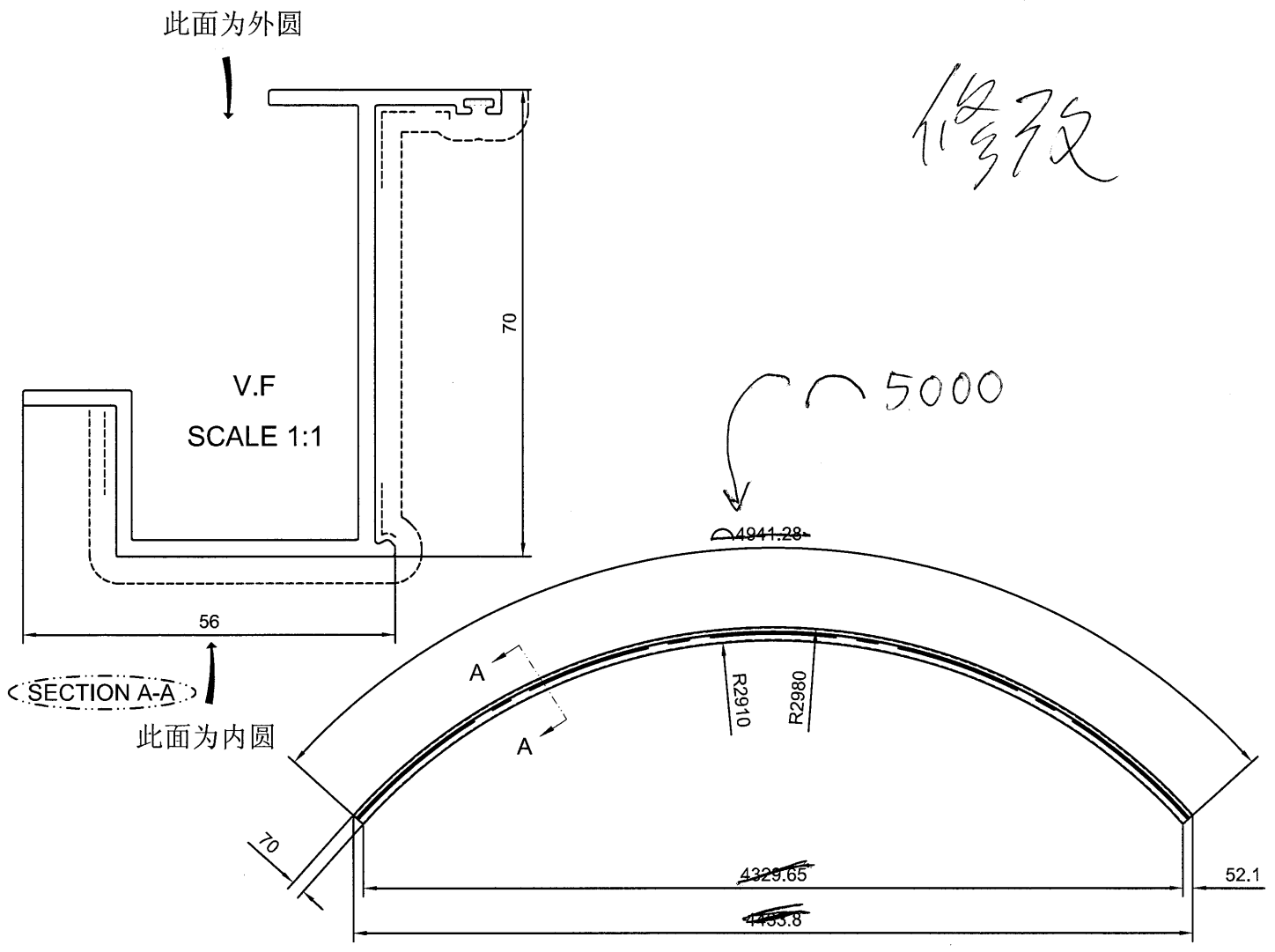

技术要求:

- 1. 平面度偏差0~1.0mm;
- 2. 扭拧度偏差0~5.0mm;
- 3. 角度变形±1.5°;
- 4. 产品未注公差±3.0mm;
- 5. 允许两端各预留10mm钳口位。

Total weight: 5.791 kg/pcs  
 Unspecified Fabricated Tolerance:±3.0

拉弯前展开长度: 4941.28 mm  
 外弧长度: 5000 mm

SIGNATURE GRADEING	HIGH SIGNATURE GRADEING	C.C.DIA(MM)	Ø93.07						
AREA (SQ MM)	432.6	UNSPECIFIED THICKNESS	2.3±0.2	PERIMETER (MM)	370.19	STANDARD	BS EN755	SCALE	1:35
MASS (KG/M)	1.172	UNSPECIFIED CORNERS	R 0.3	SURFACE AREA	166.52	ALLOY	6063-T6	VERSION	B
		DRAWN	陈晓舒	DATE	2019-04-12	APPELLATION	-	PAGE OF	
		STANDARDIZATION		DATE					
		TO SIGN	陈国提	DATE					
		AUDITING		DATE					
MARKER	MODIFY	FILE NO	SIGNATURE	DATE	APPROV	DATE			

CUSTOMER	HONGKONG CO.	CUSTOMER APPROVAL	CUST PART NO.	J837-WH-25
			SECTION NO.	LH0090289(F09)

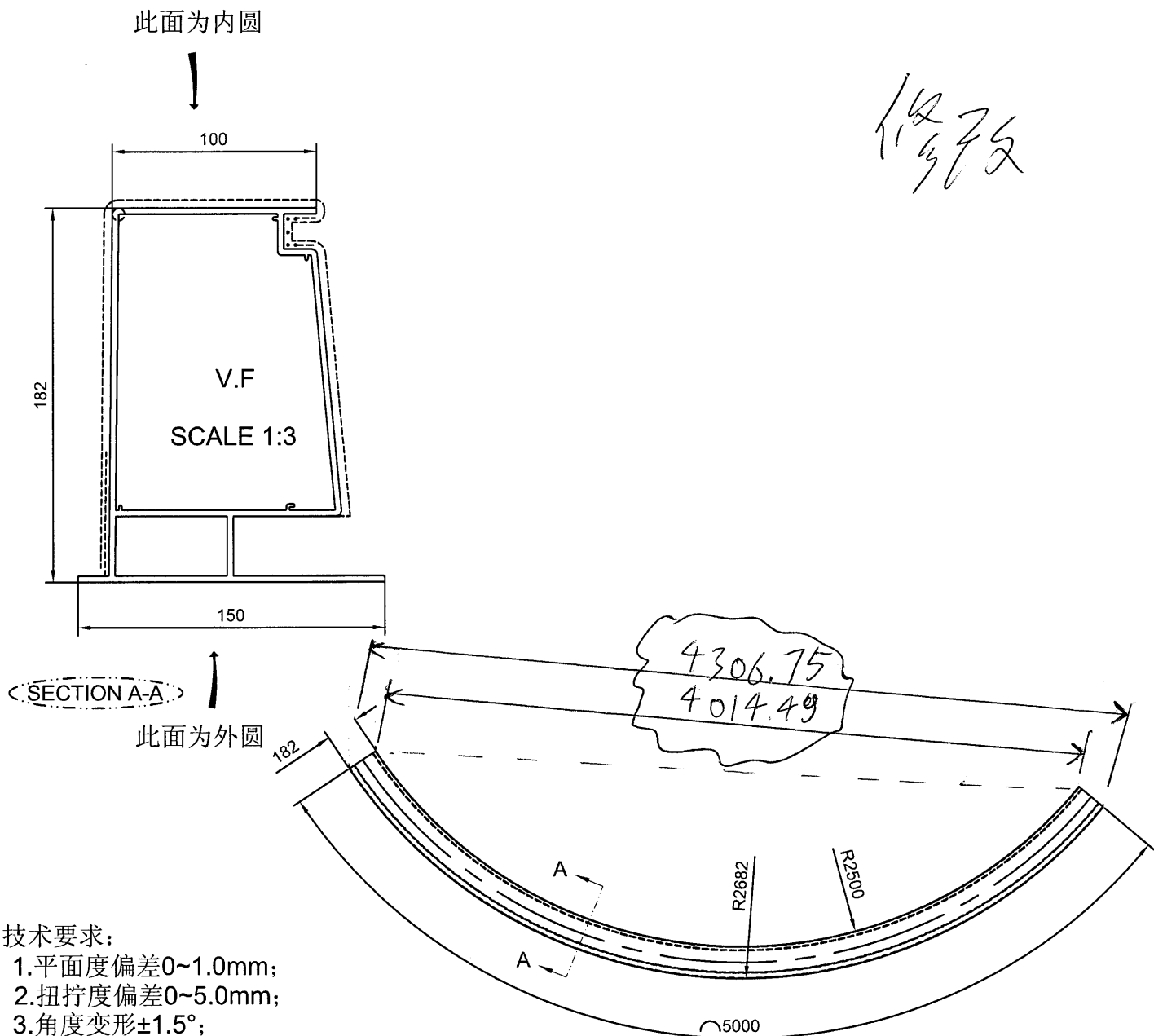

- 技术要求:
- 1.平面度偏差0~1.0mm;
  - 2.扭拧度偏差0~5.0mm;
  - 3.角度变形±1.5°;
  - 4.产品未注公差±3.0mm;
  - 5.允许两端各预留10mm钳口位。
- Total weight: 28.707 kg/pcs  
 Unspecified Fabricated Tolerance:±3.0

拉弯前展开长度: 4830.35 mm  
 外弧长度: 5000 mm

SIGNATURE GRADEING	HIGH SIGNATURE GRADEING	C.C.DIA(MM)	Ø225.3								
AREA (SQ MM)	2193.12	UNSPECIFIED THICKNESS	3±0.25	PERIMETER (MM)	782.82	STANDARD	BS EN755	SCALE	1:35		
MASS (KG/M)	5.943	UNSPECIFIED CORNERS	R 0.3	SURFACE AREA	460.12	ALLOY	6063-T6	VERSION	B		
		DRAWN	陈晓舒	DATE	2019-04-12	APELLATION	-	PAGE OF			
		STANDARDIZATION		DATE							
		TO SIGN	陈国提	DATE							
		AUDITING		DATE							
MARKER	MODIFY	FILE NO	SIGNATURE	DATE	APPROV	DATE					

