

工程指示 / 要求簡箋(E.I.)

工程指示編號：EI / 0183 / 18

修改版次：G

工程編號：J837 平台

工程名稱：觀塘 裕民坊

工程項目：平台 Window Wall

廠用鋁料 BM

收件人：Maggie

發件人：Leung Hin Wai

日期：17/5 2019

要求提供 / 確認 事項：

- | | | |
|------------------------------------|-------------------------------------|-------------------------------|
| <input type="checkbox"/> 初步鋁料 B.M. | <input type="checkbox"/> 加工拆圖，然後生產 | <input type="checkbox"/> 尺寸表 |
| <input type="checkbox"/> 正式鋁料 B.M. | <input type="checkbox"/> 技術上資料 / 指示 | <input type="checkbox"/> 報價 |
| <input type="checkbox"/> 配件 B.M. | <input type="checkbox"/> 樣辦或貨品說明書 | <input type="checkbox"/> 分判合約 |
| <input type="checkbox"/> 其他：_____ | | |

內容：

確定 控彎圖

請在 _____ 前完成上列要求。

附： -

1 + 9 頁

以上項目為：

原合約工程包

原合約工程加 / 減賬

新工程報價

原因： -

分發東莞各部門：

- | | | | |
|---|---|---|--|
| <input type="checkbox"/> 生產技術總監 <input type="checkbox"/> 連附件 | <input type="checkbox"/> 技術部 <input type="checkbox"/> 連附件 | <input type="checkbox"/> 生產部 <input type="checkbox"/> 連附件 | <input type="checkbox"/> 機械設計部 <input type="checkbox"/> 連附件 |
| <input type="checkbox"/> 採購部 <input type="checkbox"/> 連附件 | <input checked="" type="checkbox"/> 生產統籌部 <input checked="" type="checkbox"/> 連附件 | | |
| <input checked="" type="checkbox"/> 質檢部 <input checked="" type="checkbox"/> 連附件 | <input type="checkbox"/> 會計部 <input type="checkbox"/> 連附件 | <input type="checkbox"/> 報關組 <input type="checkbox"/> 連附件 | <input type="checkbox"/> 其他 _____ <input type="checkbox"/> 連附件 |

分發香港各部門：

- | | | | |
|---|--|---|--|
| <input type="checkbox"/> 行政部 <input type="checkbox"/> 連附件 | <input type="checkbox"/> 會計部 <input type="checkbox"/> 連附件 | <input type="checkbox"/> 統籌部 <input type="checkbox"/> 連附件 | <input type="checkbox"/> 工程部地盤科文 <input type="checkbox"/> 連附件 |
| <input type="checkbox"/> 採購部 <input type="checkbox"/> 連附件 | <input type="checkbox"/> QS 部 <input type="checkbox"/> 連附件 | <input type="checkbox"/> 維修部 <input type="checkbox"/> 連附件 | <input type="checkbox"/> 其他 _____ <input type="checkbox"/> 連附件 |

傳遞編號：

HK 1238 / 19

發件人簽署：

Handwritten signature

項目經理簽署：

Handwritten signature

CUSTOMER	HONGKONG CO.	CUSTOMER APPROVAL	CUST PART NO.	J837-GL-WH04
			SECTION NO.	LH0090131(F04)

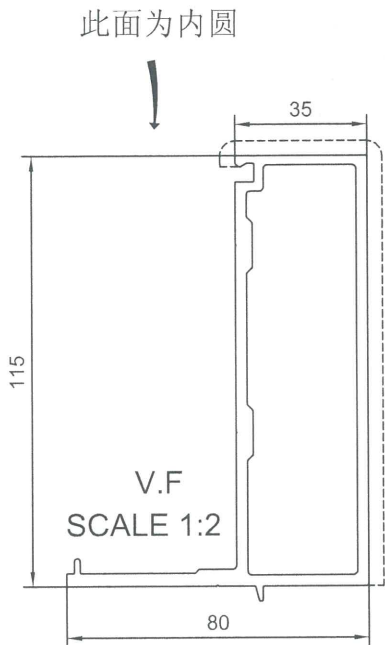

美特铝质有限公司	
承認圖面	<i>[Signature]</i>
日期	17/5-2019

SECTION A-A
此面为外圆

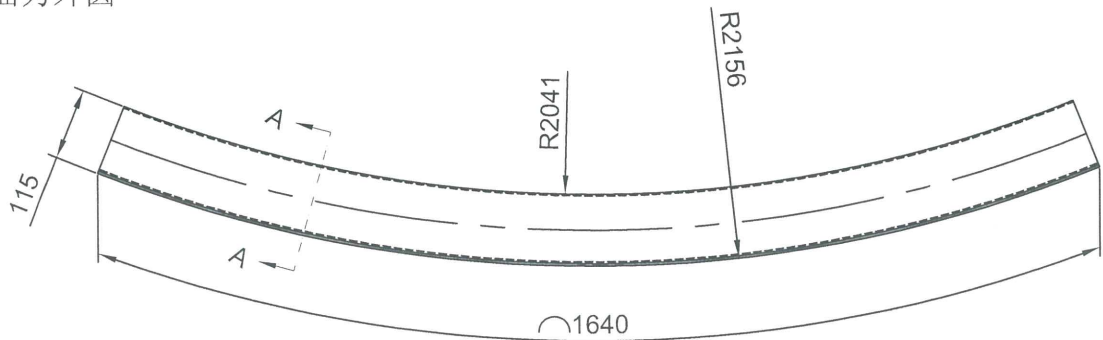

技术要求:

- 1.平面度偏差0~1.0mm;
- 2.扭拧度偏差0~5.0mm;
- 3.角度变形±1.5°;
- 4.产品未注公差±3.0mm;
- 5.允许两端各预留10mm钳口位。

Total weight: 4.666 kg/pcs
Unspecified Fabricated Tolerance: ±3.0

拉弯前展开长度: 1596.26 mm

外弧长度: 1640 mm

SIGNATURE GRADEING	HIGH SIGNATURE GRADEING	C.C.DIA(MM)	Ø139.86						
AREA (SQ MM)	1078.87	UNSPECIFIED THICKNESS	3±0.25	PERIMETER (MM)	412.96	STANDARD	BS EN755	SCALE	1:12
MASS (KG/M)	2.923	UNSPECIFIED CORNERS	R 0.3	SURFACE AREA	153.1	ALLOY	6063-T6	VERSION	C
COMPANY ISSUE		A	DRAWN	陈晓舒	DATE	2019-04-09	APPELLATION	-	PAGE OF
			STANDARDIZATION		DATE				
			TO SIGN	陈国提	DATE				
			AUDITING		DATE				
MARKER	MODIFY	FILE NO	SIGNATURE	DATE	APPROV	DATE			



CUSTOMER	HONGKONG CO.	CUSTOMER APPROVAL	CUST PART NO.	J837-GL-WH06
			SECTION NO.	LH0090132(F01)

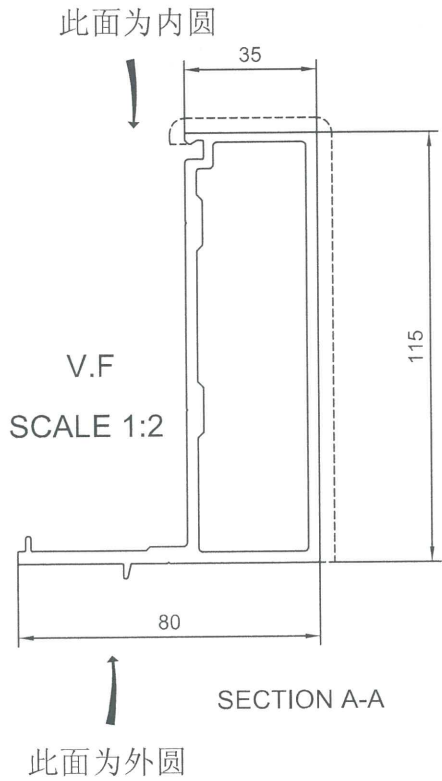

美特铝质有限公司	
承認圖面	<i>[Signature]</i>
日期	17/5-2019

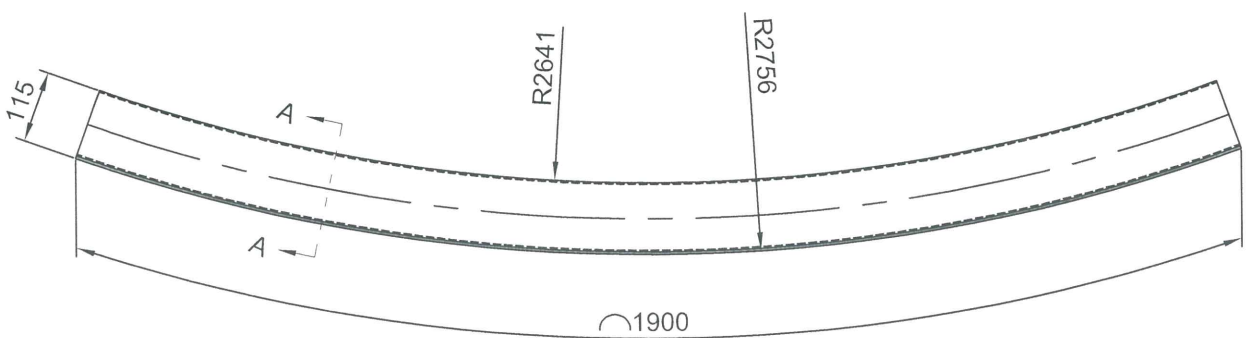

技术要求:

1. 平面度偏差0~1.0mm;
2. 扭拧度偏差0~5.0mm;
3. 角度变形±1.5°;
4. 产品未注公差±3.0mm;
5. 允许两端各预留10mm钳口位。

拉弯前展开长度: 1860.36 mm
外弧长度: 1900 mm

Total weight: 5.438 kg/pcs
Unspecified Fabricated Tolerance: ±3.0

SIGNATURE GRADEING	HIGH SIGNATURE GRADEING	C.C.DIA(MM)	Ø139.86						
AREA (SQ MM)	1078.68	UNSPECIFIED THICKNESS	3±0.25	PERIMETER (MM)	412.66	STANDARD	BS EN755	SCALE	1:12
MASS (KG/M)	2.923	UNSPECIFIED CORNERS	R 0.3	SURFACE AREA	153.1	ALLOY	6063-T6	VERSION	C
COMPANY ISSUE		A	DRAWA	陈晓舒	DATE	2019-04-09	APPELLATION	-	PAGE OF
			STANDAR-DIZATION		DATE				
			TO SIGN	陈国提	DATE				
			AUDITING		DATE				
MARKER	MODIFY	FILE NO	SIGNATURE	DATE	APPROV		DATE		



CUSTOMER	HONGKONG CO.	CUSTOMER APPROVAL	CUST PART NO.	J837-GL-WH07
			SECTION NO.	LH0090132(F02)

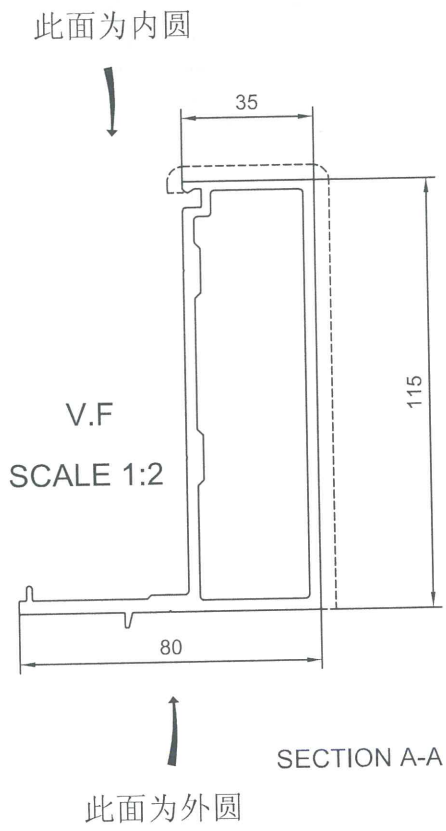

美特铝质有限公司	
承認圖面	MP
日期	17/5-2019

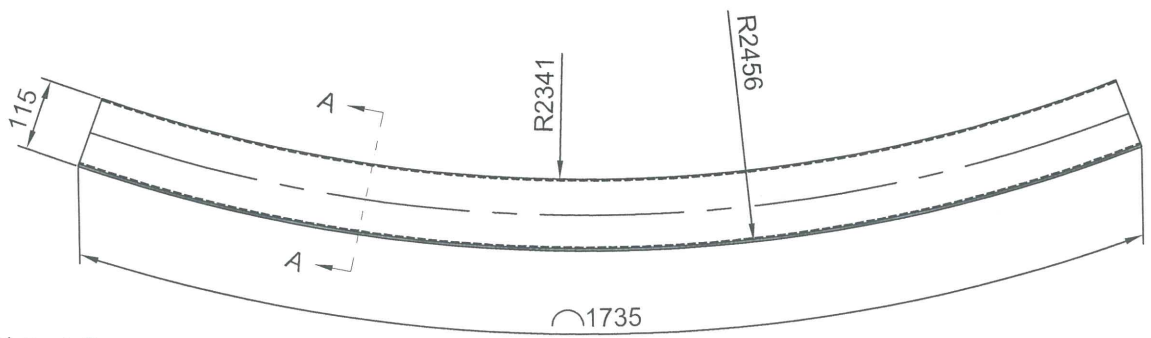

技术要求:

- 1.平面度偏差0~1.0mm;
- 2.扭拧度偏差0~5.0mm;
- 3.角度变形±1.5°;
- 4.产品未注公差±3.0mm;
- 5.允许两端各预留10mm钳口位。

Total weight: 4.953 kg/pcs

Unspecified Fabricated Tolerance:±3.0

拉弯前展开长度: 1694.38 mm

外弧长度: 1735 mm

SIGNATURE GRADEING	HIGH SIGNATURE GRADEING	C.C.DIA(MM)	Ø139.86							
AREA (SQ MM)	1078.68	UNSPECIFIED THICKNESS	3±0.25	PERIMETER (MM)	412.66	STANDARD	BS EN755	SCALE	1:12	
MASS (KG/M)	2.923	UNSPECIFIED CORNERS	R 0.3	SURFACE AREA	153.1	ALLOY	6063-T6	VERSION	C	
COMPANY ISSUE		A	DRAWN	陈晓舒	DATE	2019-04-09	APPELLATION	-	PAGE OF	
			STANDARDIZATION		DATE					
			TO SIGN	陈国提	DATE					
			AUDITING		DATE					
MARKER	MODIFY	FILE NO	SIGNATURE	DATE	APPROV	DATE				



PANASIA ALUMINUM (CHINA) LIMITED

CUSTOMER	HONGKONG CO.	CUSTOMER APPROVAL	CUST PART NO.	J837-GL-WH09
			SECTION NO.	LH0090132(F04)

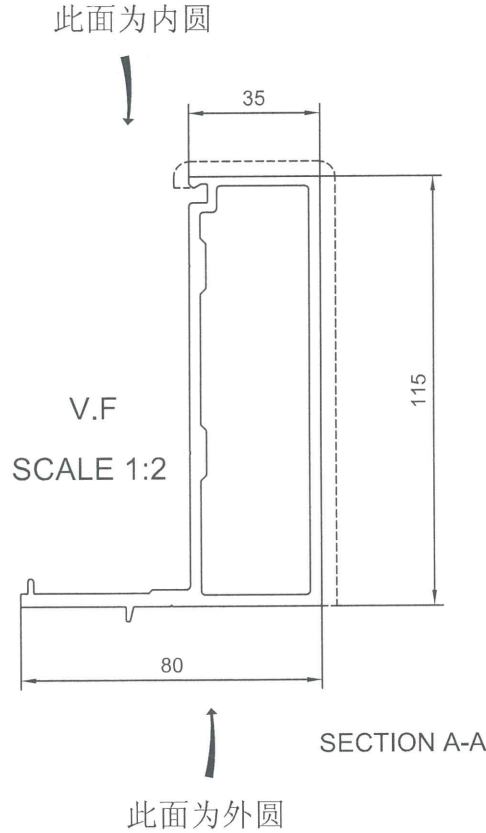

美特铝质有限公司	
承認圖面	<i>[Signature]</i>
日期	17/5-2019

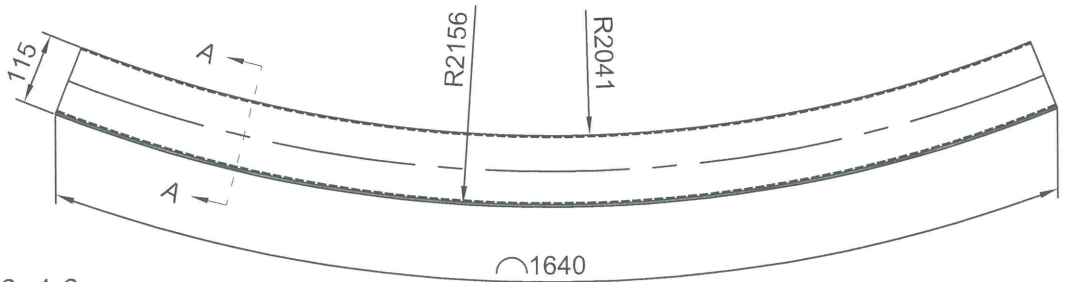

技术要求:

- 1.平面度偏差0~1.0mm;
 - 2.扭拧度偏差0~5.0mm;
 - 3.角度变形±1.5°;
 - 4.产品未注公差±3.0mm;
 - 5.允许两端各预留10mm钳口位。
- Total weight: 4.666 kg/pcs
Unspecified Fabricated Tolerance:±3.0

拉弯前展开长度: 1596.26 mm
外弧长度: 1640 mm

SIGNATURE GRADEING	HIGH SIGNATURE GRADEING	C.C.DIA(MM)	Ø139.86						
AREA (SQ MM)	1078.68	UNSPECIFIED THICKNESS	3±0.25	PERIMETER (MM)	412.66	STANDARD	BS EN755	SCALE	1:12
MASS (KG/M)	2.923	UNSPECIFIED CORNERS	R 0.3	SURFACE AREA	153.1	ALLOY	6063-T6	VERSION	C
COMPANY ISSUE		A	DRAWN	陈晓舒	DATE	2019-04-09	APPELLATION	-	PAGE OF
			STANDARDIZATION		DATE				
			TO SIGN	陈国提	DATE				
			AUDITING		DATE				
MARKER	MODIFY	FILE NO	SIGNATURE	DATE	APPROV				



CUSTOMER	HONGKONG CO.	CUSTOMER APPROVAL	CUST PART NO.	J837-GL-WH11
			SECTION NO.	LH0090134(F01)

此面为内圆

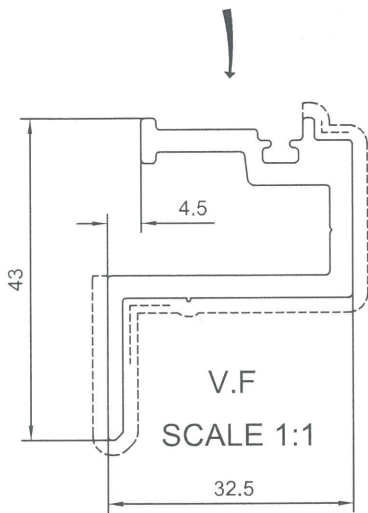

SECTION A-A

此面为外圆

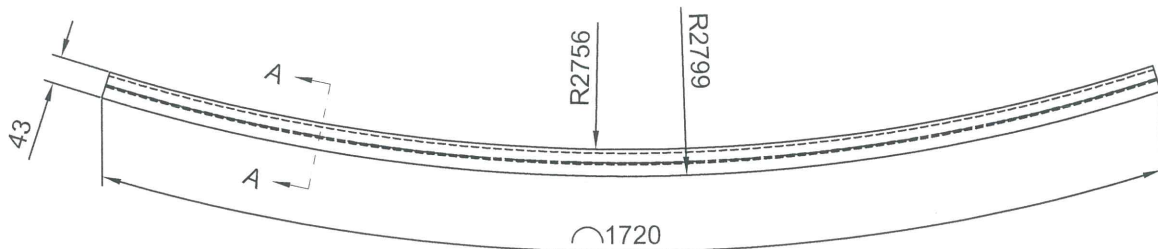

美特铝质有限公司	
承認圖面	<i>[Signature]</i>
日期	17/5-2019

技术要求:

1. 平面度偏差0~1.0mm;
2. 扭拧度偏差0~5.0mm;
3. 角度变形±1.5°;
4. 产品未注公差±3.0mm;
5. 允许两端各预留10mm钳口位。

Total weight: 1.377 kg/pcs
Unspecified Fabricated Tolerance:±3.0

拉弯前展开长度: 1706.79 mm

外弧长度: 1720 mm

SIGNATURE GRADEING	HIGH SIGNATURE GRADEING	C.C.DIA(MM)	Ø 59.55						
AREA (SQ MM)	297.76	UNSPECIFIED THICKNESS	3.0±0.25	PERIMETER (MM)	214.26	STANDARD	BS EN755	SCALE	1:12
MASS (KG/M)	0.807	UNSPECIFIED CORNERS	R 0.5	SURFACE AREA	103.44	ALLOY	6063-T6	VERSION	C
COMPANY ISSUE		A	DRAWA	陈晓舒	DATE	2019-04-09	APPELLATION	-	PAGE OF
			STANDA-RDIZATION		DATE				
			TO SIGN	陈国提	DATE				
			AUDITING		DATE				
MARKER	MODIFY	FILE NO	SIGNATURE	DATE	APPROV				



CUSTOMER	HONGKONG CO.	CUSTOMER APPROVAL	CUST PART NO.	J837-GL-WH12
			SECTION NO.	LH0090134(F02)

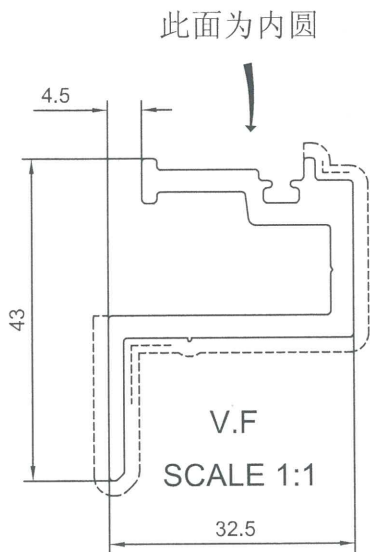

美特铝质有限公司	
承认图面	<i>SP</i>
日期	17/5-2019

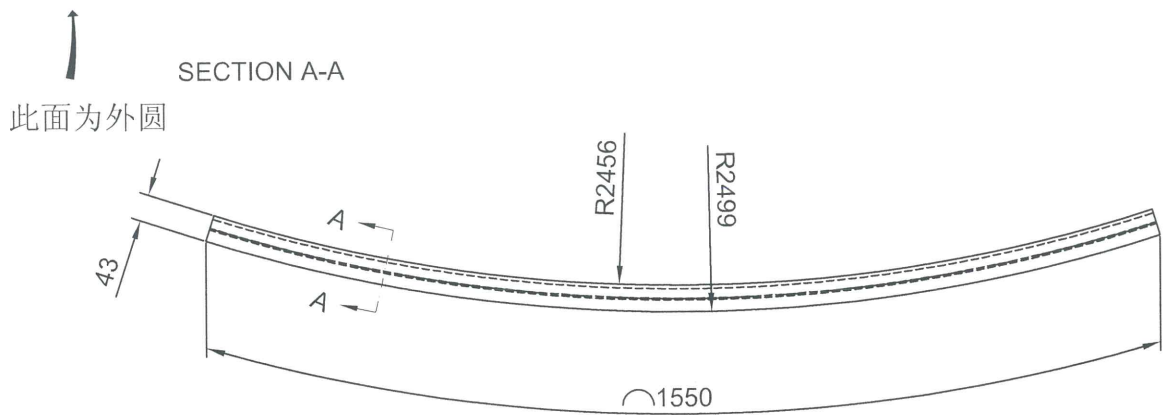

技术要求:

- 1.平面度偏差0~1.0mm;
- 2.扭拧度偏差0~5.0mm;
- 3.角度变形±1.5°;
- 4.产品未注公差±3.0mm;
- 5.允许两端各预留10mm钳口位。

Total weight: 1.240 kg/pcs

Unspecified Fabricated Tolerance:±3.0

拉弯前展开长度: 1536.67 mm

外弧长度: 1550 mm

SIGNATURE GRADEING	HIGH SIGNATURE GRADEING	C.C.DIA(MM)	Ø59.55						
AREA (SQ MM)	297.76	UNSPECIFIED THICKNESS	3.0±0.25	PERIMETER (MM)	214.26	STANDARD	BS EN755	SCALE	1:12
MASS (KG/M)	0.807	UNSPECIFIED CORNERS	R 0.5	SURFACE AREA	103.44	ALLOY	6063-T6	VERSION	C
COMPANY ISSUE		A	DRAWN	陈晓舒	DATE	2019-04-09	APPELLATION	-	PAGE OF
			STANDARDIZATION		DATE				
			TO SIGN	陈国提	DATE				
			AUDITING		DATE				
MARKER	MODIFY	FILE NO	SIGNATURE	DATE	APPROV		DATE		



CUSTOMER	HONGKONG CO.	CUSTOMER APPROVAL	CUST PART NO.	J837-GL-WH14
			SECTION NO.	LH0090134(F04)

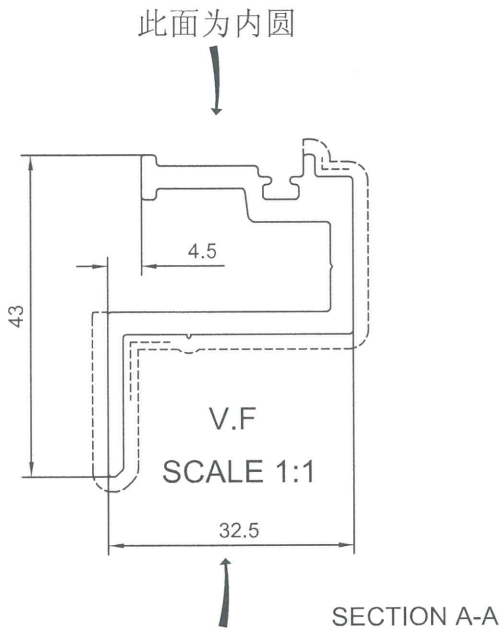

美特铝质有限公司	
承認圖面	<i>[Signature]</i>
日期	17/5/2019

此面为外圆

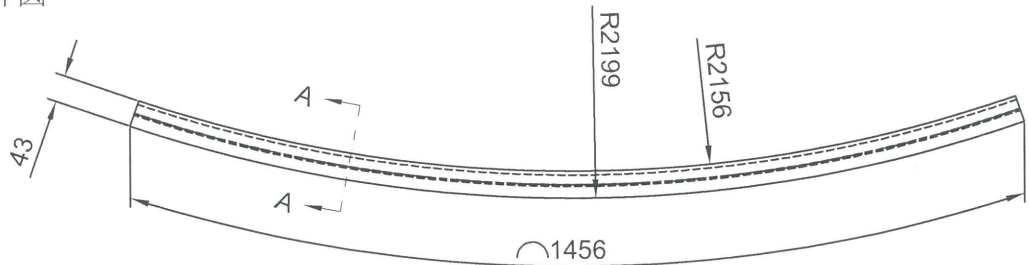

技术要求:

- 1.平面度偏差0~1.0mm;
- 2.扭拧度偏差0~5.0mm;
- 3.角度变形±1.5°;
- 4.产品未注公差±3.0mm;
- 5.允许两端各预留10mm钳口位。

Total weight: 1.164 kg/pcs

Unspecified Fabricated Tolerance:±3.0

拉弯前展开长度: 1441.77 mm

外弧长度: 1456 mm

SIGNATURE GRADEING	HIGH SIGNATURE GRADEING	C.C.DIA(MM)	Ø59.55						
AREA (SQ MM)	297.76	UNSPECIFIED THICKNESS	3.0±0.25	PERIMETER (MM)	214.26	STANDARD	BS EN755	SCALE	1:12
MASS (KG/M)	0.807	UNSPECIFIED CORNERS	R 0.5	SURFACE AREA	103.44	ALLOY	6063-T6	VERSION	C
COMPANY ISSUE		A	DRAWN	陈晓舒	DATE	2019-04-09	APPELLATION	-	PAGE OF
			STANDARDIZATION		DATE				
			TO SIGN	陈国提	DATE				
			AUDITING		DATE				
MARKER	MODIFY	FILE NO	SIGNATURE	DATE	APPROV		DATE		



CUSTOMER	HONGKONG CO.	CUSTOMER APPROVAL	CUST PART NO.	J837-GL-WH21
			SECTION NO.	LH0090166(F06)

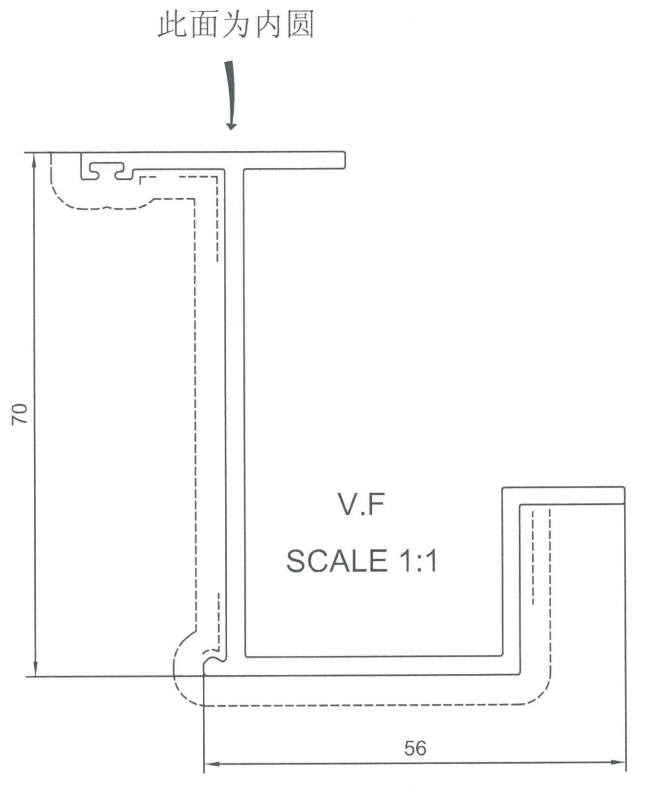

美特铝质有限公司	
承認圖面	<i>Handwritten signature</i>
日期	12/5-2019

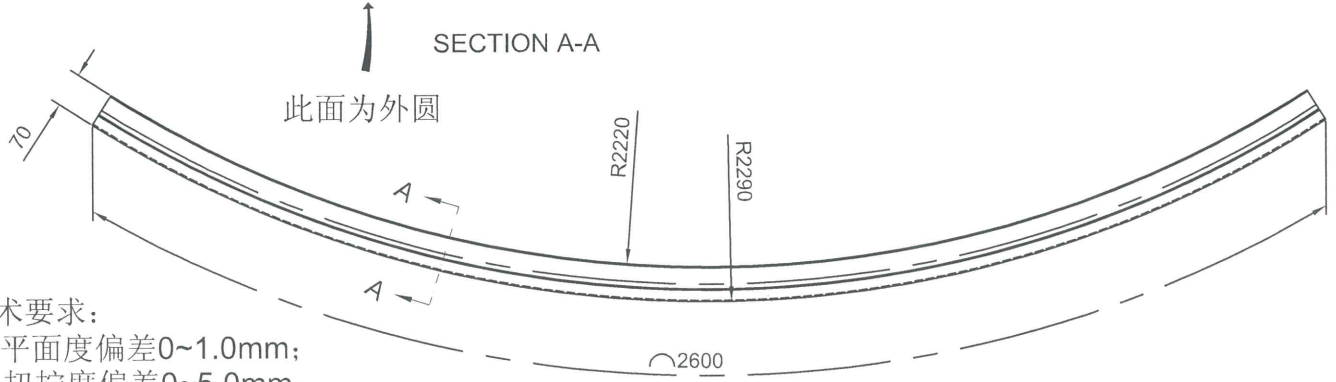

技术要求:

- 1. 平面度偏差0~1.0mm;
- 2. 扭拧度偏差0~5.0mm;
- 3. 角度变形±1.5°;
- 4. 产品未注公差±3.0mm;
- 5. 允许两端各预留10mm钳口位。

Total weight: 3.000 kg/pcs
 Unspecified Fabricated Tolerance: ±3.0

拉弯前展开长度: 2560.26 mm
 外弧长度: 2600 mm

SIGNATURE GRADEING	HIGH SIGNATURE GRADEING	C.C.DIA(MM)	Ø93.07						
AREA (SQ MM)	432.6	UNSPECIFIED THICKNESS	2.3±0.2	PERIMETER (MM)	370.19	STANDARD	BS EN755	SCALE	1:15
MASS (KG/M)	1.172	UNSPECIFIED CORNERS	R 0.3	SURFACE AREA	166.52	ALLOY	6063-T5	VERSION	C
COMPANY ISSUE		A	DRAWN	陈晓舒	DATE	2019-04-09	APPELLATION	-	PAGE OF
			STANDARDIZATION		DATE				
			TO SIGN	陈国提	DATE				
			AUDITING		DATE				
MARKER	MODIFY	FILE NO	SIGNATURE	DATE	APPROV	DATE			



CUSTOMER	HONGKONG CO.	CUSTOMER APPROVAL	CUST PART NO.	J837-GL-WH22
			SECTION NO.	LH0090165(F06)

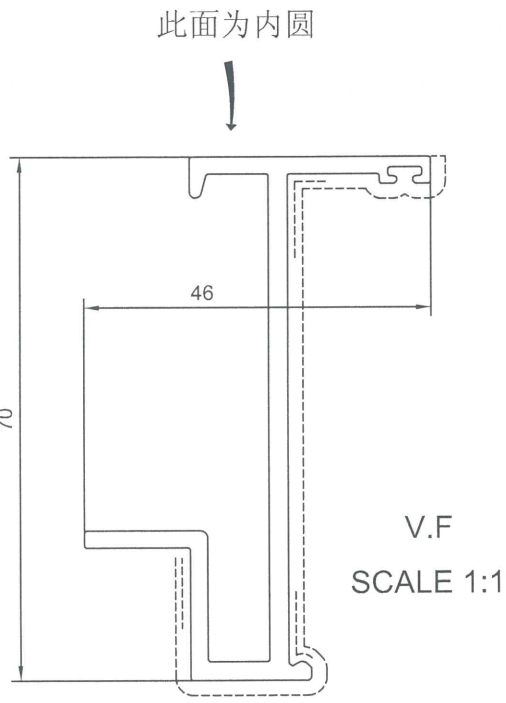

美特铝质有限公司	
承认图面	<i>[Signature]</i>
日期	17/5-2019

SECTION A-A

此面为外圆

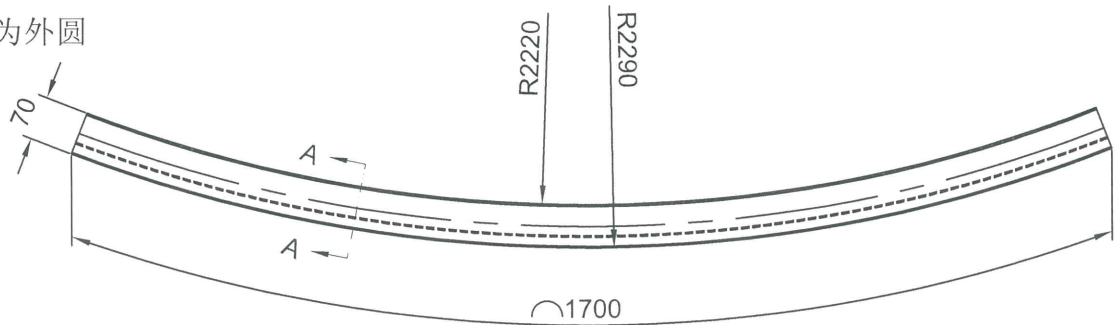

技术要求:

- 1.平面度偏差0~1.0mm;
- 2.扭拧度偏差0~5.0mm;
- 3.角度变形±1.5°;
- 4.产品未注公差±3.0mm;
- 5.允许两端各预留10mm钳口位。

Total weight: 1.609 kg/pcs

Unspecified Fabricated Tolerance:±3.0

拉弯前展开长度: 1674.02 mm

外弧长度: 1700 mm

SIGNATURE GRADEING	HIGH SIGNATURE GRADEING	C.C.DIA(MM)	Ø76.78						
AREA (SQ MM)	354.71	UNSPECIFIED THICKNESS	2.3±0.2	PERIMETER (MM)	307.08	STANDARD	BS EN755	SCALE	1:12
MASS (KG/M)	0.961	UNSPECIFIED CORNERS	R 0.3	SURFACE AREA	135.52	ALLOY	6063-T5	VERSION	C
COMPANY ISSUE		A	DRAWN	陈晓舒	DATE	2019-04-09	APPELLATION	-	PAGE OF
			STANDARDIZATION		DATE				
			TO SIGN	陈国提	DATE				
			AUDITING		DATE				
MARKER	MODIFY	FILE NO	SIGNATURE	DATE	APPROV	DATE			



PANASIA ALUMINUM (CHINA) LIMITED