



工程指示 / 要求簡箋(E.I.)

工程指示編號：EI / 0090 / 18

修改版次：C

工程編號：J837 平台

工程名稱：觀塘 裕民坊

工程項目：平台 Canopy 雨棚

廠用鋁料 BM

收件人：生統 Maggie

發件人：Leung Hin Wai

日期：12/4-2019

要求提供 / 確認 事項：

- | | | |
|------------------------------------|-------------------------------------|-------------------------------|
| <input type="checkbox"/> 初步鋁料 B.M. | <input type="checkbox"/> 加工拆圖，然後生產 | <input type="checkbox"/> 尺寸表 |
| <input type="checkbox"/> 正式鋁料 B.M. | <input type="checkbox"/> 技術上資料 / 指示 | <input type="checkbox"/> 報價 |
| <input type="checkbox"/> 配件 B.M. | <input type="checkbox"/> 樣辦或貨品說明書 | <input type="checkbox"/> 分判合約 |
| <input type="checkbox"/> 其他：_____ | | |

內容：確定榮陽鋁料拉彎圖。

請在 _____ 前完成上列要求。

附：- 廿 18 頁

以上項目為：

- 原合約工程包 原合約工程加 / 減賬 新工程報價

原因：-

分發東莞各部門：

- () 生產技術總監 連附件 () 技術部 連附件 () 生產部 連附件 () 機械設計部 連附件
 () 採購部 連附件 () 生產統籌部 連附件
 () 質檢部 連附件 () 會計部 連附件 () 報關組 連附件 () 其他 _____ 連附件

分發香港各部門：

- () 行政部 連附件 () 會計部 連附件 () 統籌部 連附件 () 工程部地盤科文 連附件
 (/) 採購部 連附件 () QS 部 連附件 () 維修部 連附件 () 其他 _____ 連附件

傳遞編號：7472 0870

發件人簽署：
項目經理簽署：

CUSTOMER	HONGKONG CO.	CUSTOMER APPROVAL	CUST PART NO.	YP-XC-LH1
			SECTION NO.	LH0090291(F01)

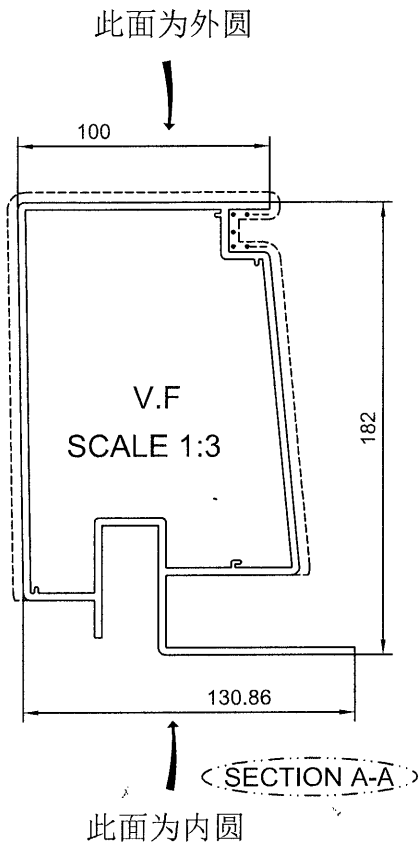

美特铝质有限公司	
承認圖面	<i>[Signature]</i>
日期	12/4-2019

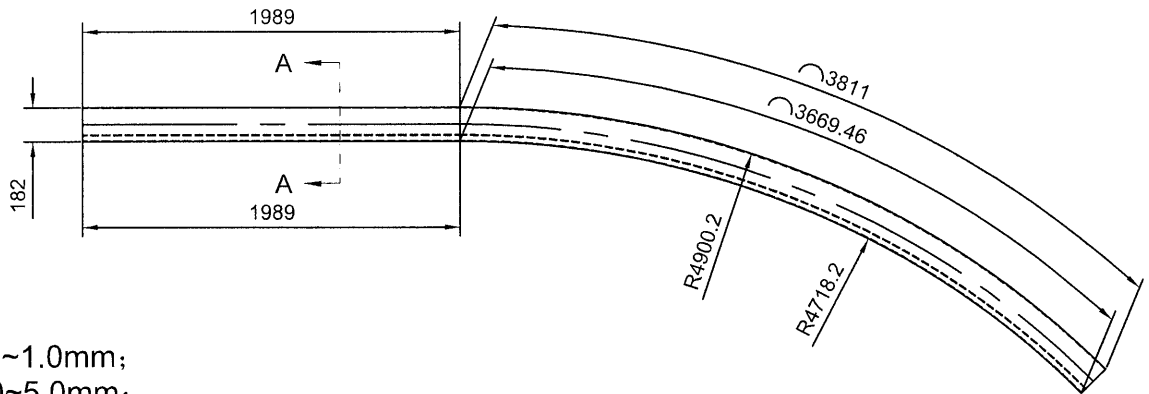

技术要求:

- 1.平面度偏差0~1.0mm;
- 2.扭拧度偏差0~5.0mm;
- 3.角度变形±1.5°;
- 4.产品未注公差±3.0mm;
- 5.允许两端各预留10mm钳口位。

Total weight:32.525 kg/pcs

Unspecified Fabricated Tolerance:±3.0

拉弯前展开长度: 5729.23 mm

外弧长度: 5800 mm

SIGNATURE GRADEING	HIGH SIGNATURE GRADEING	C.C.DIA(MM)	Ø227.73						
AREA (SQ MM)	2094.91	UNSPECIFIED THICKNESS	3±0.25	PERIMETER (MM)	836.34	STANDARD	BS EN755	SCALE	1:40
MASS (KG/M)	5.677	UNSPECIFIED CORNERS	R 0.3	SURFACE AREA	443.17	ALLOY	6063-T6	VERSION	B
COMPANY ISSUE		A	DRAWN	蔡晓婷	DATE	2019-04-11	APELLATION	-	PAGE OF
			STANDARDIZATION		DATE				
			TO SIGN	陈国提	DATE				
			AUDITING		DATE				
MARKER	MODIFY	FILE NO	SIGNATURE	DATE	APPROV	DATE			

 PANASIA ALUMINUM (CHINA) LIMITED

CUSTOMER	HONGKONG CO.	CUSTOMER APPROVAL	CUST PART NO.	YP-XC-LH2
			SECTION NO.	LH0090291(F02)

此面为外圆

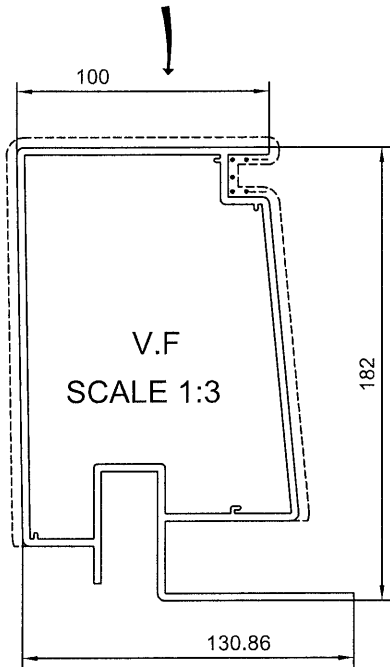

美特铝质有限公司	
承認圖面	<i>[Signature]</i>
日期	12/4-2019

SECTION A-A

此面为内圆

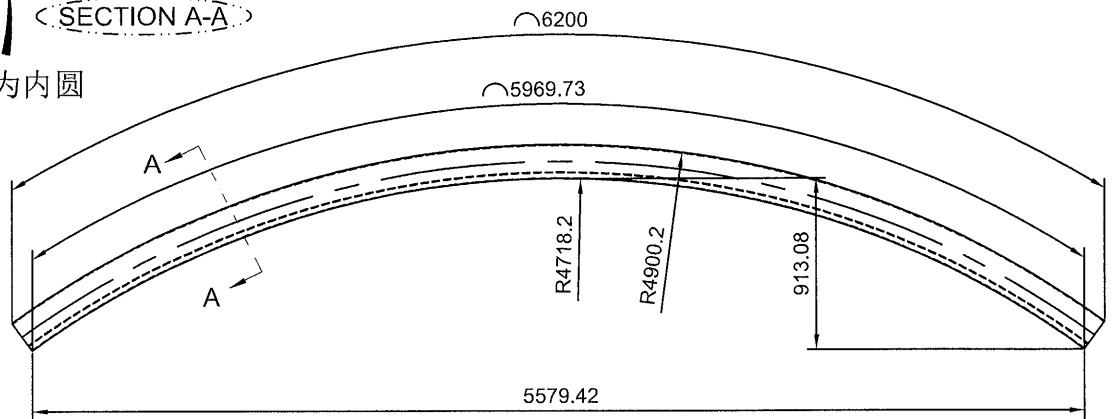

技术要求:

- 1.平面度偏差0~1.0mm;
- 2.扭拧度偏差0~5.0mm;
- 3.角度变形±1.5°;
- 4.产品未注公差±3.0mm;
- 5.允许两端各预留10mm钳口位。

拉弯前展开长度: 6084.86 mm

外弧长度: 6200 mm

Total weight: 34.544 kg/pcs

Unspecified Fabricated Tolerance:±3.0

SIGNATURE GRADEING	HIGH SIGNATURE GRADEING	C.C.DIA(MM)	Ø227.73						
AREA (SQ MM)	2094.91	UNSPECIFIED THICKNESS	3±0.25	PERIMETER (MM)	836.34	STANDARD	BS EN755	SCALE	1:40
MASS (KG/M)	5.677	UNSPECIFIED CORNERS	R 0.3	SURFACE AREA	443.17	ALLOY	6063-T6	VERSION	B
COMPANY ISSUE		A	DRAWN	蔡晓婷	DATE	2019-04-11	APELLATION	-	PAGE OF
			STANDARDIZATION		DATE				
			TO SIGN	陈国提	DATE				
			AUDITING		DATE				
MARKER	MODIFY	FILE NO	SIGNATURE	DATE	APPROV	DATE			

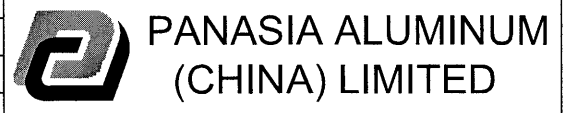

CUSTOMER	HONGKONG CO.	CUSTOMER APPROVAL	CUST PART NO.	YP-XC-LH3
			SECTION NO.	LH0090291(F03)

此面为内圆

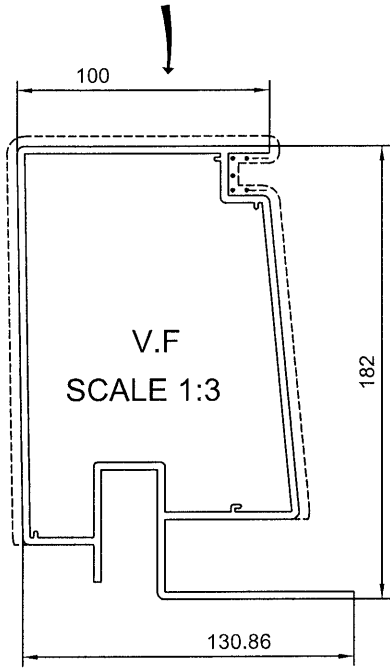

美特铝质有限公司	
承認圖面	
日期	12/9-2019

SECTION A-A

此面为外圆

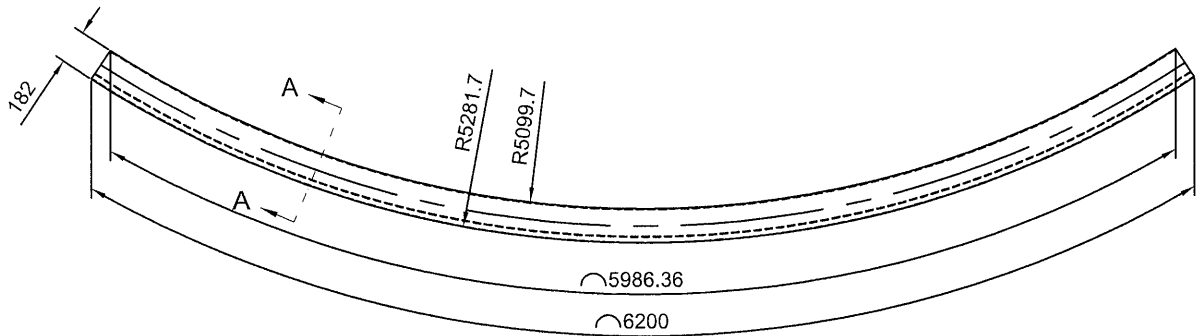

技术要求:

1. 平面度偏差0~1.0mm;
2. 扭拧度偏差0~5.0mm;
3. 角度变形±1.5°;
4. 产品未注公差±3.0mm;
5. 允许两端各预留10mm钳口位。

Total weight: 34.591 kg/pcs

Unspecified Fabricated Tolerance:±3.0

拉弯前展开长度: 6093.18 mm

外弧长度: 6200 mm

SIGNATURE GRADEING	HIGH SIGNATURE GRADEING	C.C.DIA(MM)	Ø227.73						
AREA (SQ MM)	2094.91	UNSPECIFIED THICKNESS	3±0.25	PERIMETER (MM)	836.34	STANDARD	BS EN755	SCALE	1:40
MASS (KG/M)	5.677	UNSPECIFIED CORNERS	R 0.3	SURFACE AREA	443.17	ALLOY	6063-T6	VERSION	B
COMPANY ISSUE		A	DRAWN	蔡晓婷	DATE	2019-04-11	APELLATION	-	PAGE OF
			STANDARDIZATION		DATE				
			TO SIGN	陈国提	DATE				
			AUDITING		DATE				
MARKER	MODIFY	FILE NO	SIGNATURE	DATE	APPROV	DATE			

PANASIA ALUMINUM (CHINA) LIMITED

CUSTOMER	HONGKONG CO.	CUSTOMER APPROVAL	CUST PART NO.	YP-XC-LH4
			SECTION NO.	LH0090291(F04)

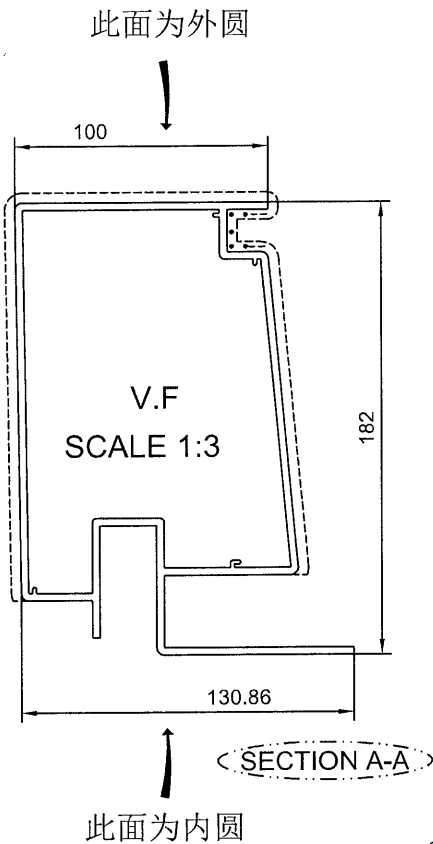

美特铝质有限公司	
承认图面	<i>[Signature]</i>
日期	12/4-2019

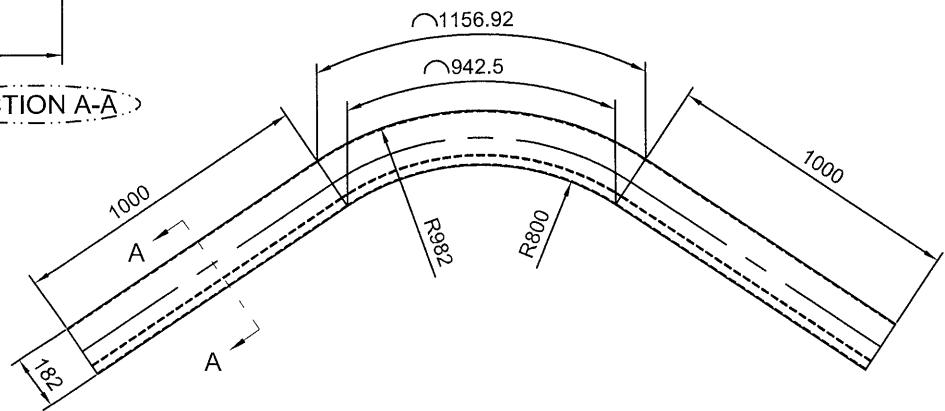

技术要求:

- 1.平面度偏差0~1.0mm;
- 2.扭拧度偏差0~5.0mm;
- 3.角度变形±1.5°;
- 4.产品未注公差±3.0mm;
- 5.允许两端各预留10mm钳口位。

Total weight: 17.313 kg/pcs

Unspecified Fabricated Tolerance:±3.0

拉弯前展开长度: 3049.71 mm

外弧长度: 3156.92 mm

SIGNATURE GRADEING	HIGH SIGNATURE GRADEING	C.C.DIA(MM)	Ø227.73						
AREA (SQ MM)	2094.91	UNSPECIFIED THICKNESS	3±0.25	PERIMETER (MM)	836.34	STANDARD	BS EN755	SCALE	1:25
MASS (KG/M)	5.677	UNSPECIFIED CORNERS	R 0.3	SURFACE AREA	443.17	ALLOY	6063-T6	VERSION	B
COMPANY ISSUE		A	DRAWA	蔡晓婷	DATE	2019-04-11	APELLATION	-	PAGE OF
			STANDA-RDIZATION		DATE				
			TO SIGN	陈国提	DATE				
			AUDITING		DATE				
MARKER	MODIFY	FILE NO	SIGNATURE	DATE	APPROV	DATE			

 PANASIA ALUMINUM (CHINA) LIMITED

CUSTOMER	HONGKONG CO.	CUSTOMER APPROVAL		CUST PART NO.	YP-XC-LH5
				SECTION NO.	LH0090291(F05)

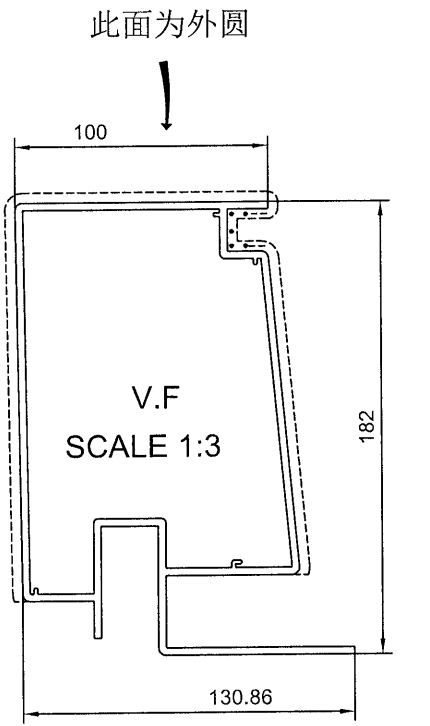

美特铝质有限公司	
承認圖面	<i>[Signature]</i>
日期	12/4-2019

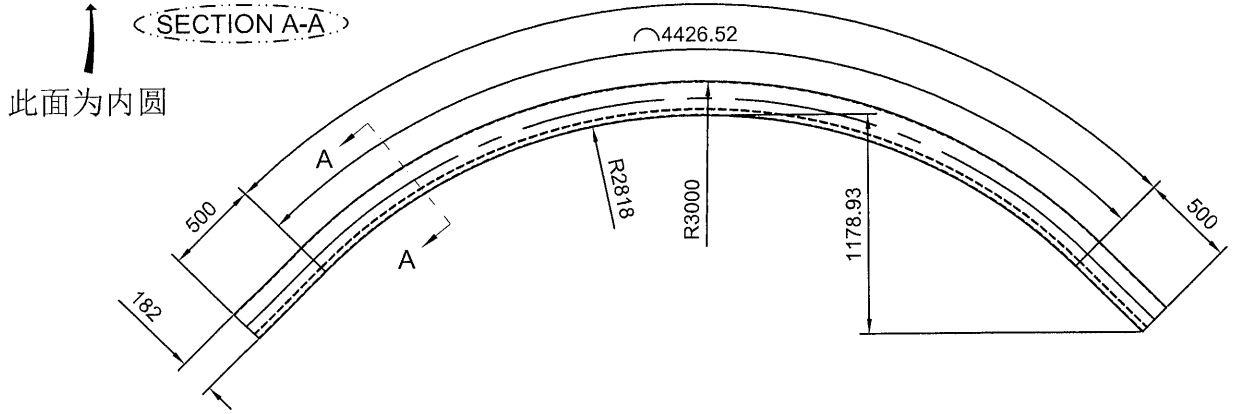

技术要求:

1. 平面度偏差0~1.0mm;
2. 扭拧度偏差0~5.0mm;
3. 角度变形±1.5°;
4. 产品未注公差±3.0mm;
5. 允许两端各预留10mm钳口位。

拉弯前展开长度: 5569.46 mm

外弧长度: 5712.4 mm

Total weight: 31.618 kg/pcs

Unspecified Fabricated Tolerance: ±3.0

SIGNATURE GRADEING	HIGH SIGNATURE GRADEING	C.C.DIA(MM)	Ø227.73							
AREA (SQ MM)	2094.91	UNSPECIFIED THICKNESS	3±0.25	PERIMETER (MM)	836.34	STANDARD	BS EN755	SCALE	1:40	
MASS (KG/M)	5.677	UNSPECIFIED CORNERS	R 0.3	SURFACE AREA	443.17	ALLOY	6063-T6	VERSION	B	
COMPANY ISSUE		A	DRAWA	蔡晓婷	DATE	2019-04-11	APPELLATION	-	PAGE OF	
			STANDA-RDIZATION		DATE					
			TO SIGN	陈国提	DATE					
			AUDITING		DATE					
MARKER	MODIFY	FILE NO	SIGNATURE	DATE	APPROV	DATE				



CUSTOMER	HONGKONG CO.	CUSTOMER APPROVAL	CUST PART NO.	YP-XC-LH6
			SECTION NO.	LH0090291(F06)

此面为外圆

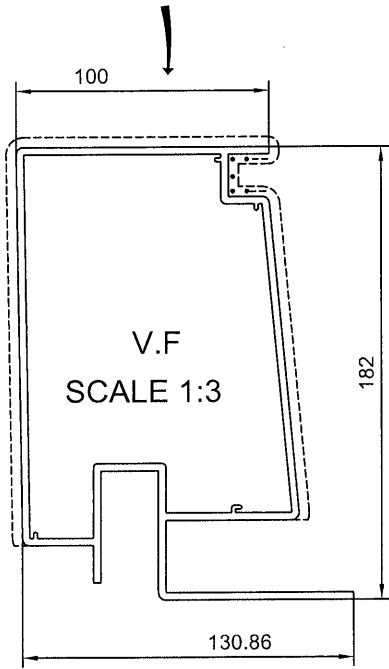

美特铝质有限公司	
承認圖面	<i>[Signature]</i>
日期	12/9-2019

此面为内圆

SECTION A-A

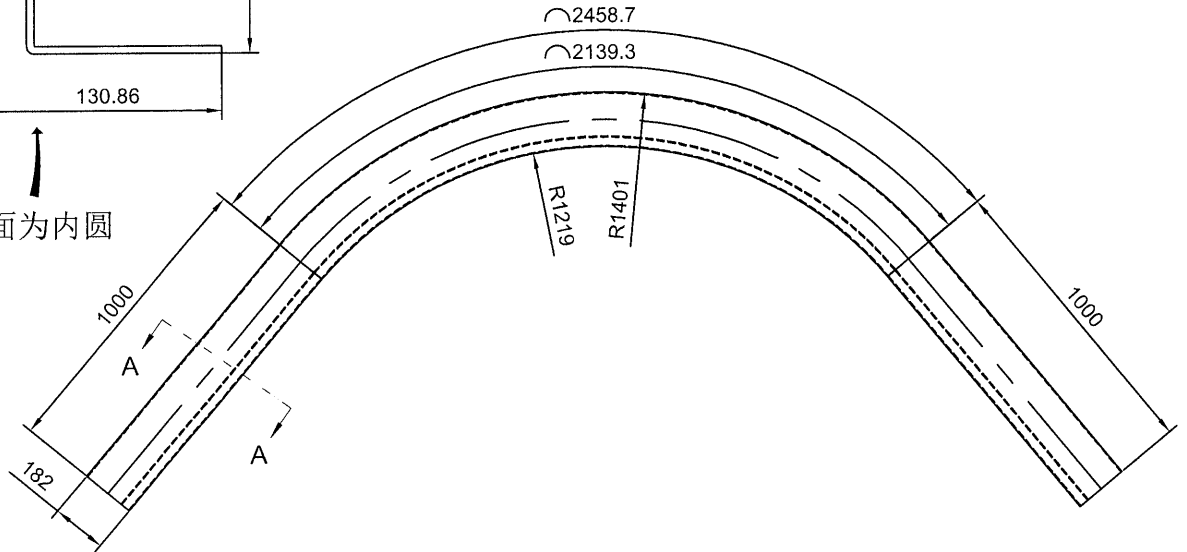

技术要求:

1. 平面度偏差0~1.0mm;
2. 扭拧度偏差0~5.0mm;
3. 角度变形±1.5°;
4. 产品未注公差±3.0mm;
5. 允许两端各预留10mm钳口位。

Total weight: 24.405 kg/pcs
Unspecified Fabricated Tolerance:±3.0

拉弯前展开长度: 4299 mm

外弧长度: 4458.7 mm

SIGNATURE GRADEING	HIGH SIGNATURE GRADEING	C.C.DIA(MM)	Ø227.73						
AREA (SQ MM)	2094.91	UNSPECIFIED THICKNESS	3±0.25	PERIMETER (MM)	836.34	STANDARD	BS EN755	SCALE	1:25
MASS (KG/M)	5.677	UNSPECIFIED CORNERS	R 0.3	SURFACE AREA	443.17	ALLOY	6063-T6	VERSION	B
COMPANY ISSUE		A	DRAWA	蔡晓婷	DATE	2019-04-11	APPELLATION	-	PAGE OF
			STANDA-RDIZATION		DATE				
			TO SIGN	陈国提	DATE				
			AUDITING		DATE				
MARKER	MODIFY	FILE NO	SIGNATURE	DATE	APPROV	DATE			



CUSTOMER	HONGKONG CO.	CUSTOMER APPROVAL	CUST PART NO.	YP-XC-LH16
			SECTION NO.	LH0090290(F01)

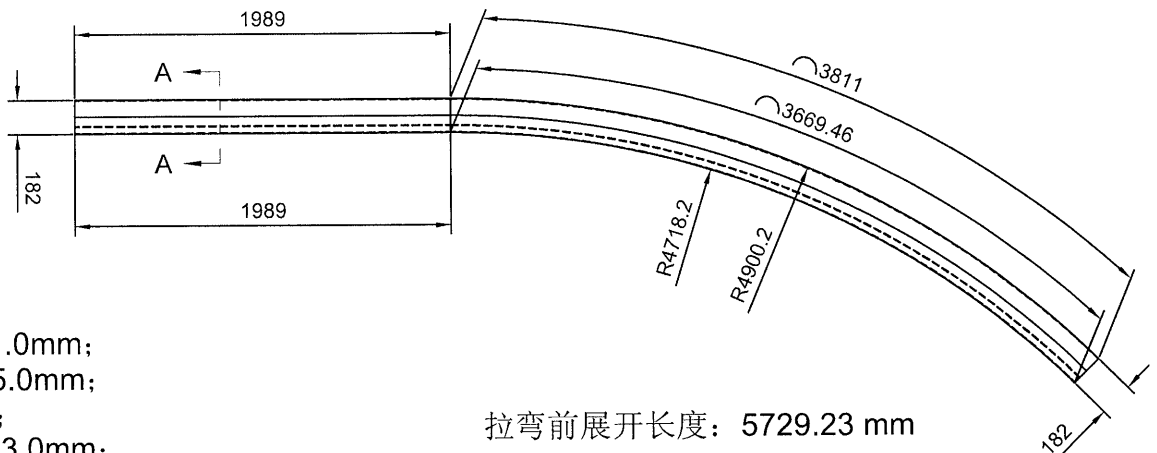
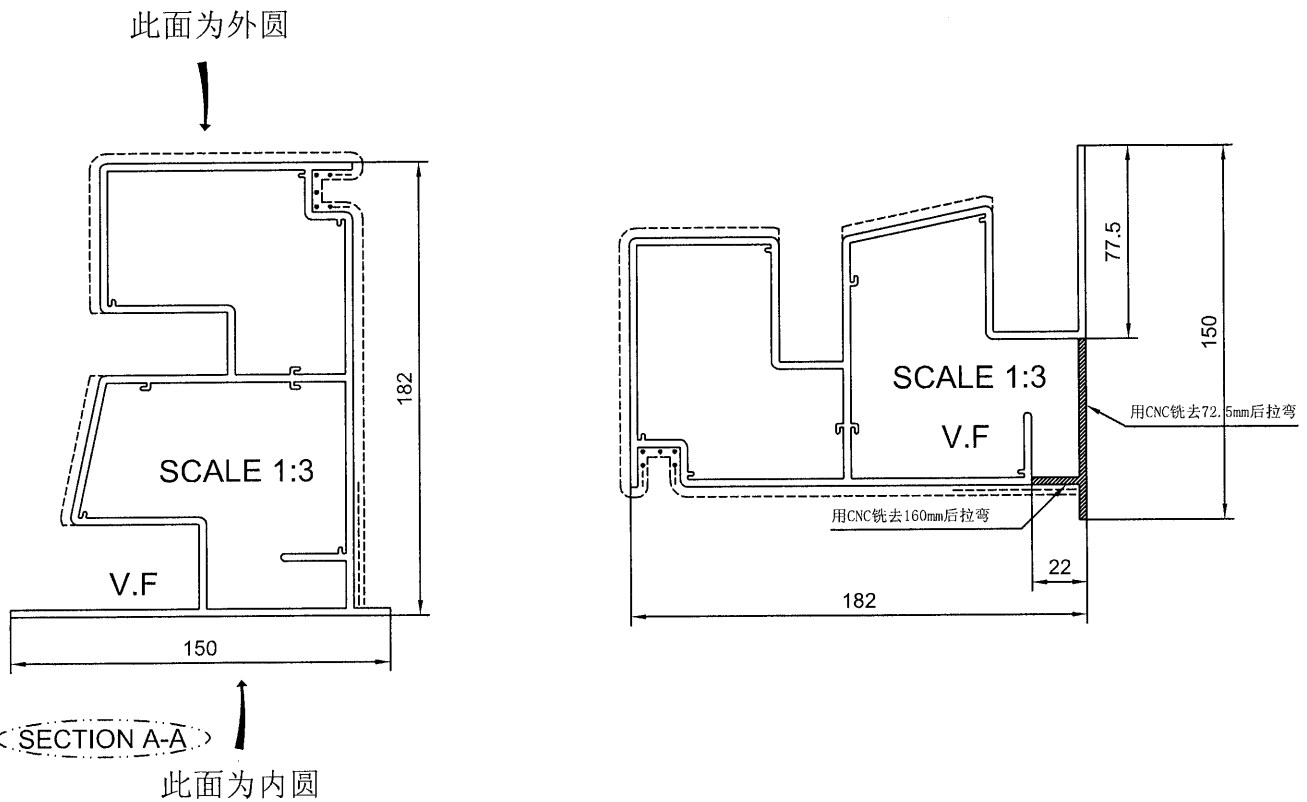

技术要求:

1. 平面度偏差0~1.0mm;
2. 扭拧度偏差0~5.0mm;
3. 角度变形 $\pm 1.5^\circ$;
4. 产品未注公差 ± 3.0 mm;
5. 允许两端各预留10mm钳口位。

Total weight: 39.514 kg/pcs

Unspecified Fabricated Tolerance: ± 3.0

拉弯前展开长度: 5729.23 mm

外弧长度: 5800 mm

美特铝质有限公司	
承認圖面	2/4
日期	2/4-2019

SIGNATURE GRADEING	HIGH SIGNATURE GRADEING	C.C.DIA(MM)	Ø227.56						
AREA (SQ MM)	2545.02	UNSPECIFIED THICKNESS	3±0.25	PERIMETER (MM)	878.28	STANDARD	BS EN755	SCALE	1:40
MASS (KG/M)	6.897	UNSPECIFIED CORNERS	R 0.3	SURFACE AREA	434.22	ALLOY	6063-T6	VERSION	D
		DRAWA	陈晓舒	DATE	2019-03-27	APPELLATION	-	PAGE OF	
		STANDA-RDIZATION		DATE					
		TO SIGN	陈国提	DATE					
		AUDITING		DATE					
MARKER	MODIFY	FILE NO	SIGNATURE	DATE	APPROV	DATE			



PANASIA ALUMINUM
(CHINA) LIMITED

CUSTOMER	HONGKONG CO.	CUSTOMER APPROVAL	CUST PART NO.	YP-XC-LH17
			SECTION NO.	LH0090290(F02)

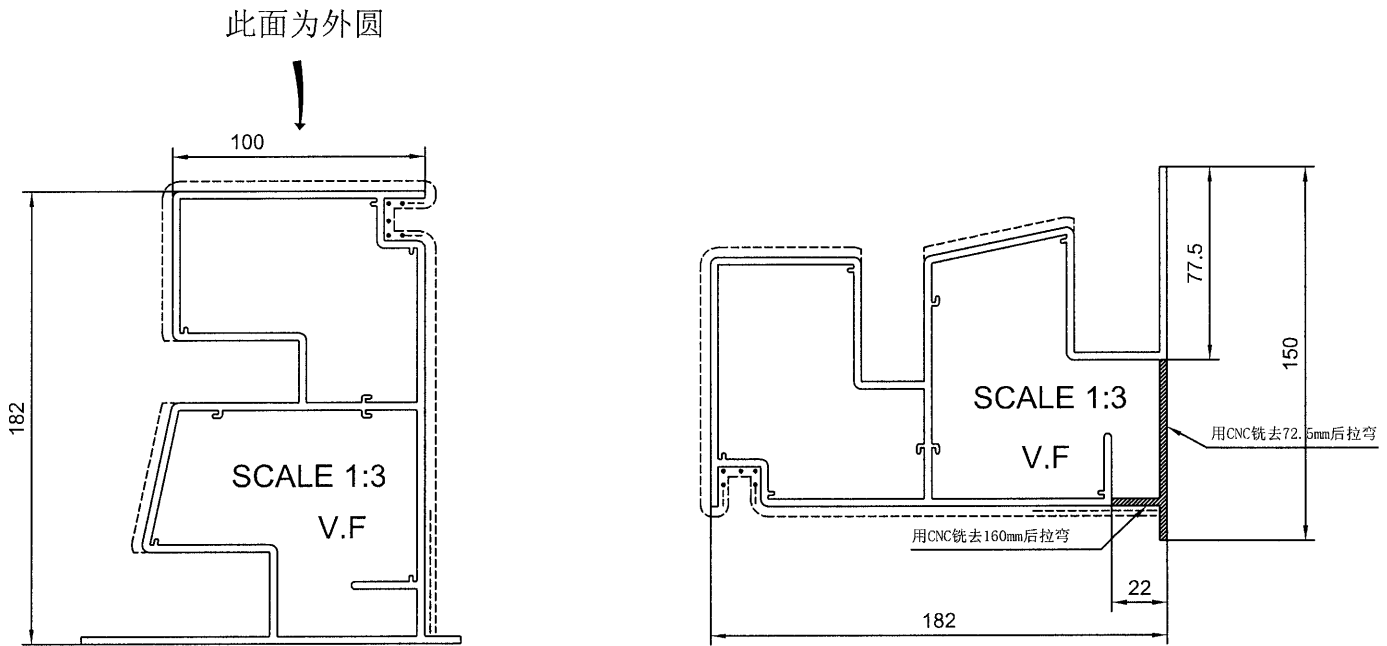

SECTION A-A

此面为内圆

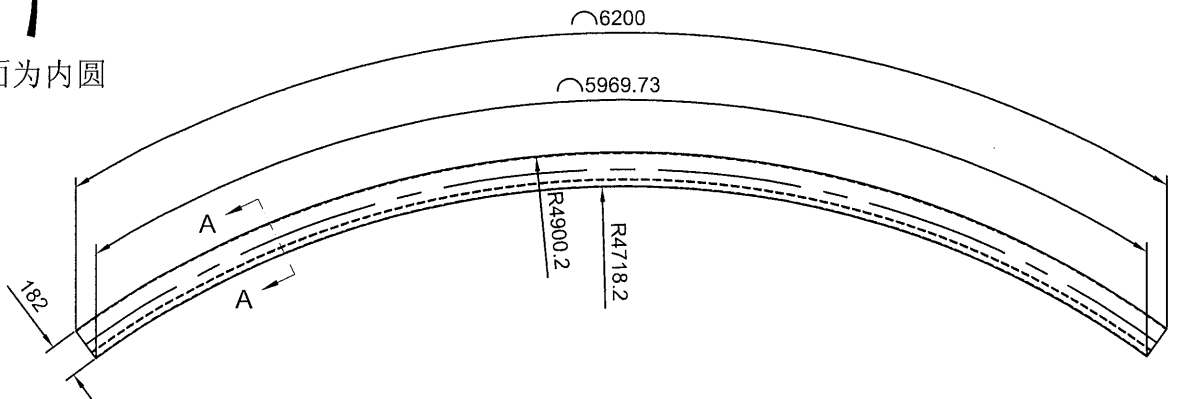

技术要求:

- 1.平面度偏差0~1.0mm;
- 2.扭拧度偏差0~5.0mm;
- 3.角度变形 $\pm 1.5^\circ$;
- 4.产品未注公差 ± 3.0 mm;
- 5.允许两端各预留10mm钳口位。

Total weight: 41.967 kg/pcs

Unspecified Fabricated Tolerance: ± 3.0

拉弯前展开长度: 6084.86 mm

外弧长度: 6200 mm

潘特铝质有限公司	
承認圖面	仲
日期	12/9-2019

SIGNATURE GRADEING	HIGH SIGNATURE GRADEING	C.C.DIA(MM)	Ø227.56						
AREA (SQ MM)	2545.02	UNSPECIFIED THICKNESS	3±0.25	PERIMETER (MM)	878.28	STANDARD	BS EN755	SCALE	1:40
MASS (KG/M)	6.897	UNSPECIFIED CORNERS	R 0.3	SURFACE AREA	434.22	ALLOY	6063-T6	VERSION	D
		DRAWN	陈晓舒	DATE	2019-03-27	APELLATION	-	PAGE OF	
		STANDARDIZATION		DATE					
		TO SIGN	陈国提	DATE					
		AUDITING		DATE					
MARKER	MODIFY	FILE NO	SIGNATURE	DATE	APPROV				



PANSIA ALUMINUM
(CHINA) LIMITED

CUSTOMER	HONGKONG CO.	CUSTOMER APPROVAL	CUST PART NO.	YP-XC-LH18
			SECTION NO.	LH0090290(F03)

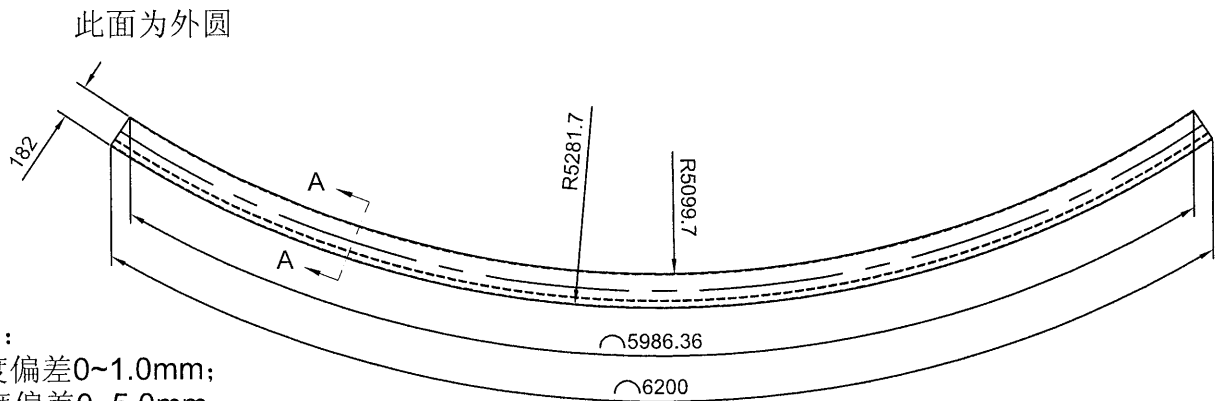
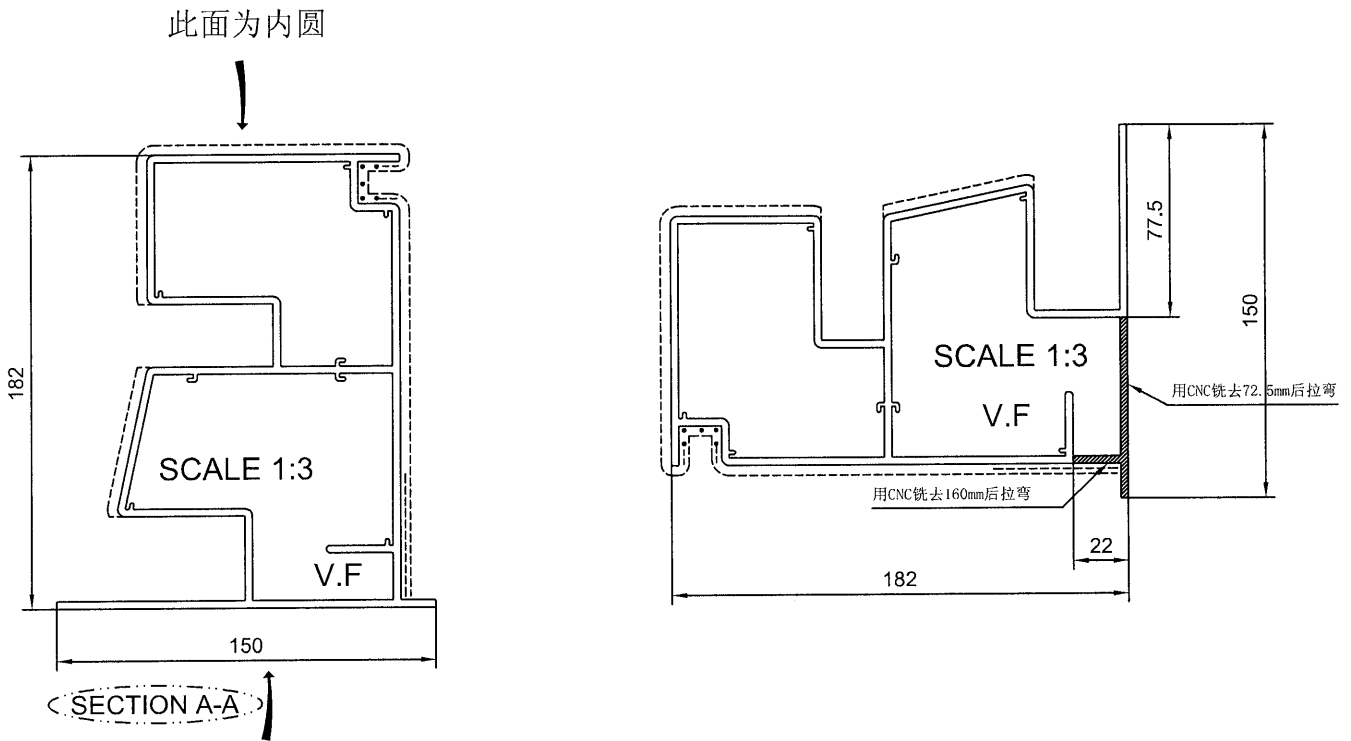

技术要求:

1. 平面度偏差0~1.0mm;
2. 扭拧度偏差0~5.0mm;
3. 角度变形 $\pm 1.5^\circ$;
4. 产品未注公差 ± 3.0 mm;
5. 允许两端各预留10mm钳口位。

Total weight: 42.025 kg/pcs

Unspecified Fabricated Tolerance: ± 3.0

拉弯前展开长度: 6093.18 mm

外弧长度: 6200 mm

特铝质有限公司	
承認圖面	<i>HP</i>
日期	12/4-2019

SIGNATURE GRADE/ING	HIGH SIGNATURE GRADE/ING	C.C.DIA(MM)	Ø227.56						
AREA (SQ MM)	2545.02	UNSPECIFIED THICKNESS	3 \pm 0.25	PERIMETER (MM)	878.28	STANDARD	BS EN755	SCALE	1:35
MASS (KG/M)	6.897	UNSPECIFIED CORNERS	R 0.3	SURFACE AREA	434.22	ALLOY	6063-T6	VERSION	D
		DRAWN	陈晓舒	DATE	2019-03-27	APPELLATION	-	PAGE OF	
		STANDARDIZATION		DATE					
		TO SIGN	陈国提	DATE					
		AUDITING		DATE					
MARKER	MODIFY	FILE NO	SIGNATURE	DATE	APPROV	DATE			



PANSIA ALUMINUM
(CHINA) LIMITED

CUSTOMER	HONGKONG CO.	CUSTOMER APPROVAL	CUST PART NO.	YP-XC-LH19
			SECTION NO.	LH0090290(F04)

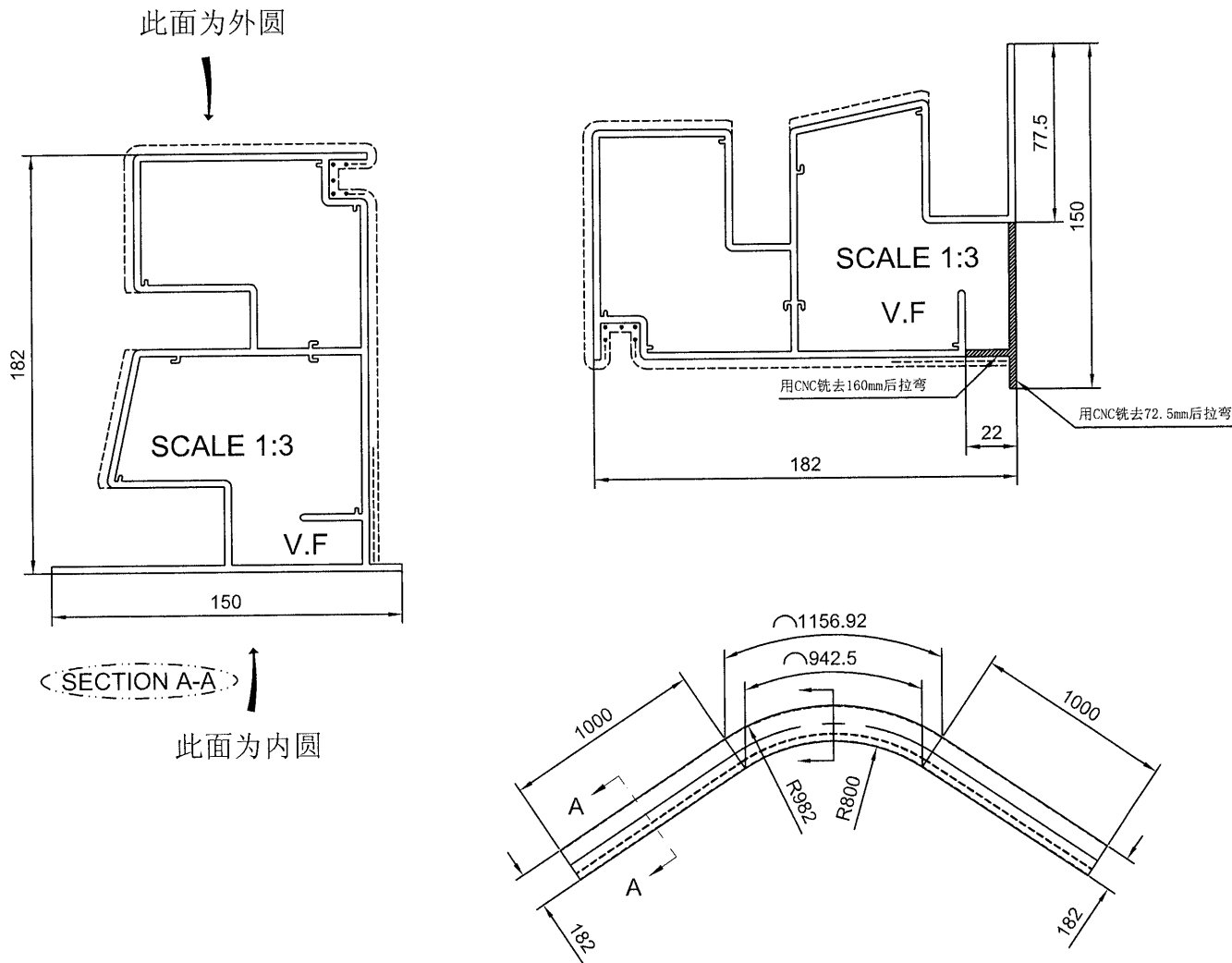

技术要求:

- 1.平面度偏差0~1.0mm;
- 2.扭拧度偏差0~5.0mm;
- 3.角度变形±1.5°;
- 4.产品未注公差±3.0mm;
- 5.允许两端各预留10mm钳口位。

Total weight: 21.034 kg/pcs
 Unspecified Fabricated Tolerance:±3.0

拉弯前展开长度: 3049.71 mm

外弧长度: 3156.92 mm

美特铝质有限公司	
承认图面	<i>[Signature]</i>
日期	12/4-2019

SIGNATURE GRADEING	HIGH SIGNATURE GRADEING	C.C.DIA(MM)	Ø227.56							
AREA (SQ MM)	2545.02	UNSPECIFIED THICKNESS	3±0.25	PERIMETER (MM)	878.28	STANDARD	BS EN755	SCALE	1:35	
MASS (KG/M)	6.897	UNSPECIFIED CORNERS	R 0.3	SURFACE AREA	434.22	ALLOY	6063-T6	VERSION	D	
		DRAWA	陈晓舒	DATE	2019-03-28	APPELLATION			PAGE OF	
		STANDA-RDIZATION		DATE						
		TO SIGN	陈国提	DATE						
		AUDITING		DATE						
MARKER	MODIFY	FILE NO	SIGNATURE	DATE	APPROV	DATE				



CUSTOMER	HONGKONG CO.	CUSTOMER APPROVAL	CUST PART NO.	YP-XC-LH20
			SECTION NO.	LH0090290(F05)

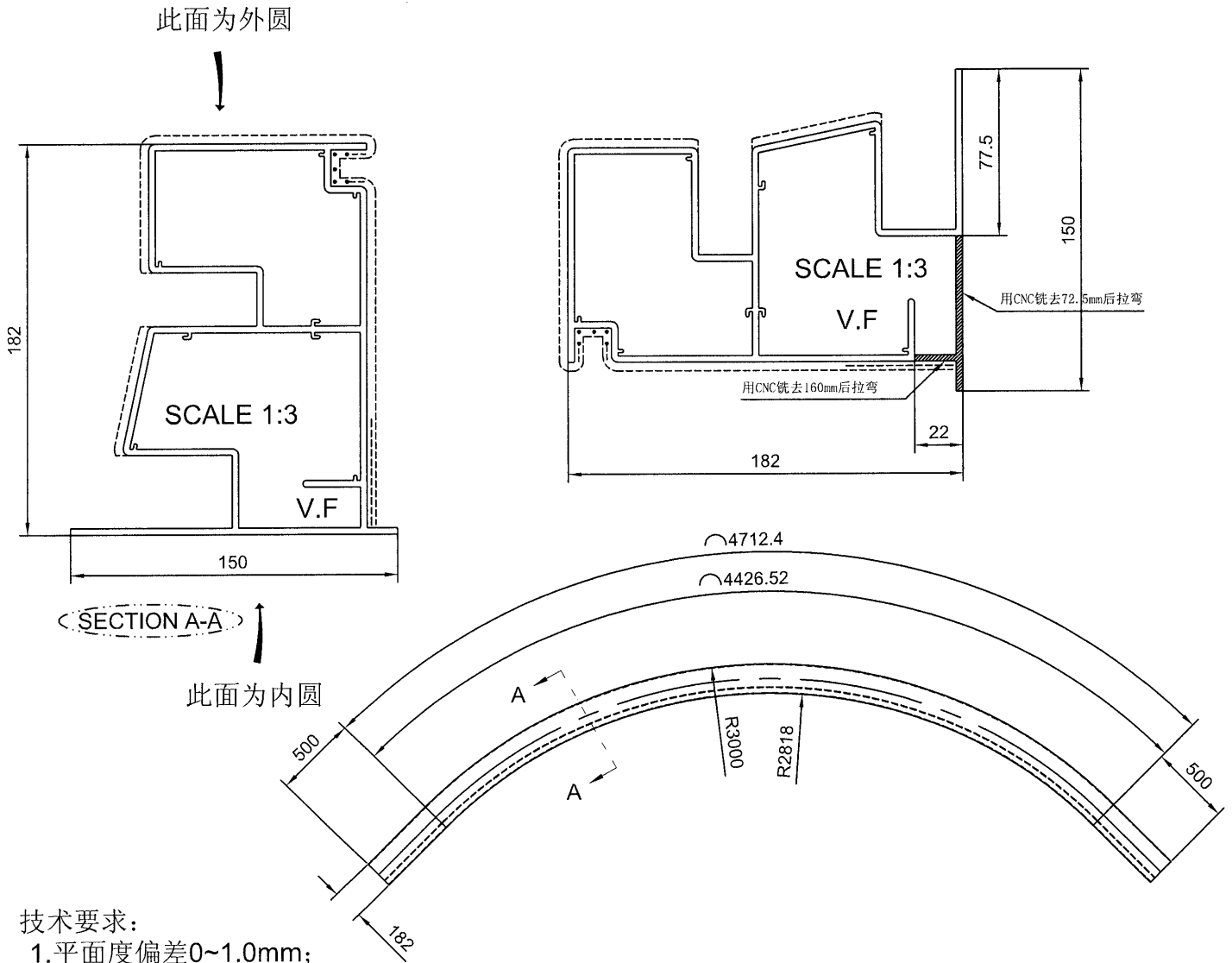

技术要求:

1. 平面度偏差0~1.0mm;
2. 扭拧度偏差0~5.0mm;
3. 角度变形±1.5°;
4. 产品未注公差±3.0mm;
5. 允许两端各预留10mm钳口位。

Total weight: 38.413 kg/pcs

Unspecified Fabricated Tolerance: ±3.0

拉弯前展开长度: 5569.46 mm

外弧长度: 5712.4 mm

奥特铝质有限公司	
承認圖面	
日期	12/4-2019

SIGNATURE GRADEING	HIGH SIGNATURE GRADEING	C.C.DIA(MM)	Ø227.56							
AREA (SQ MM)	2545.02	UNSPECIFIED THICKNESS	3±0.25	PERIMETER (MM)	878.28	STANDARD	BS EN755	SCALE	1:40	
MASS (KG/M)	6.897	UNSPECIFIED CORNERS	R 0.3	SURFACE AREA	434.22	ALLOY	6063-T6	VERSION	D	
-		-		DRAWN	陈晓舒	DATE	2019-03-28	APPELLATION	-	PAGE OF
				STANDARDIZATION		DATE				
				TO SIGN	陈国提	DATE				
				AUDITING		DATE				
MARKER	MODIFY	FILE NO	SIGNATURE	DATE	APPROV	DATE				

PANSIA ALUMINUM (CHINA) LIMITED

CUSTOMER	HONGKONG CO.	CUSTOMER APPROVAL	CUST PART NO.	YP-XC-LH21
			SECTION NO.	LH0090290(F11)

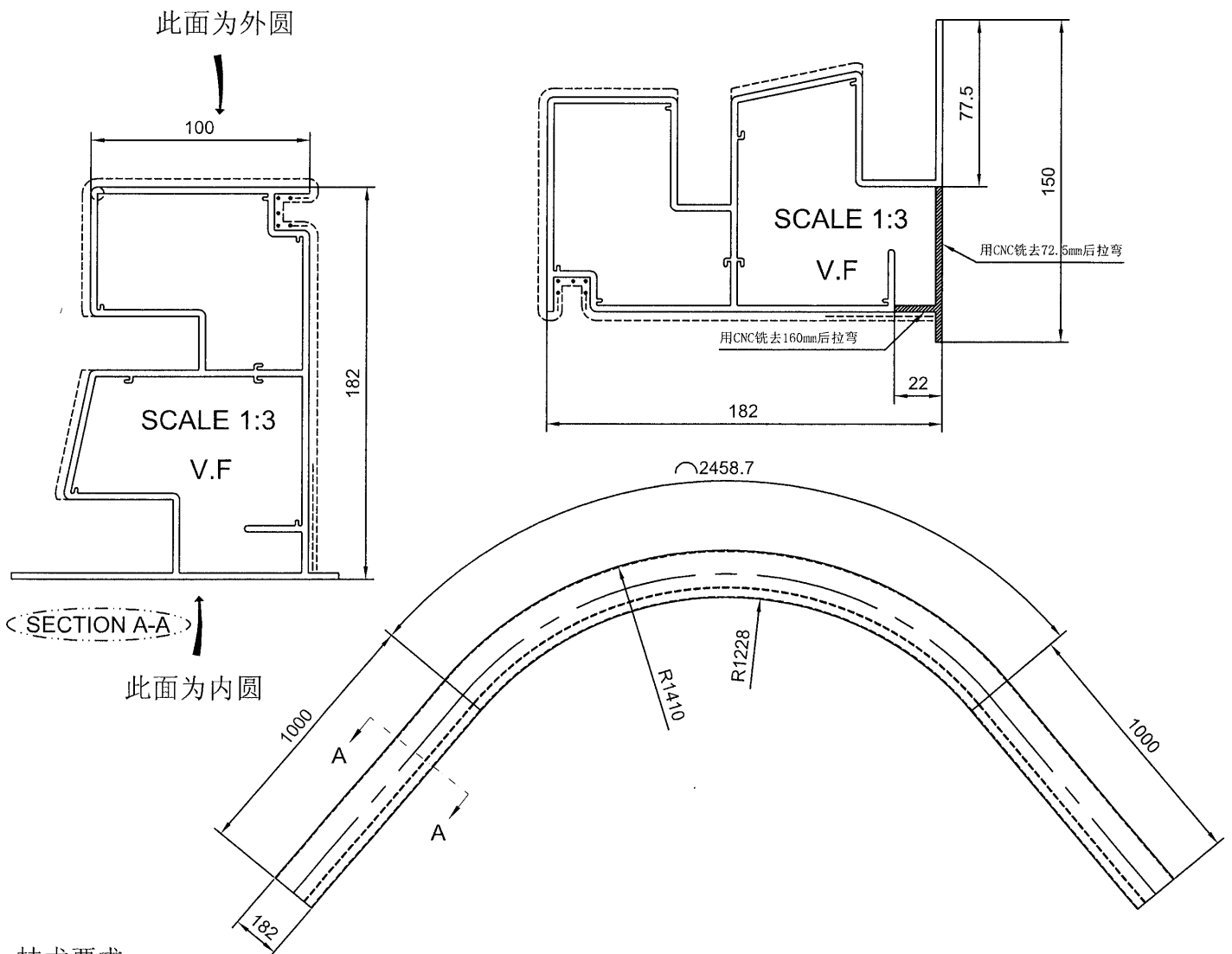

技术要求:

- 1.平面度偏差0~1.0mm;
- 2.扭拧度偏差0~5.0mm;
- 3.角度变形±1.5°;
- 4.产品未注公差±3.0mm;
- 5.允许两端各预留10mm钳口位。

Total weight: 29.657 kg/pcs
 Unspecified Fabricated Tolerance:±3.0

拉弯前展开长度: 4300.02 mm
 外弧长度: 4458.7 mm

美特铝质有限公司	
承認圖面	<i>[Signature]</i>
日期	12/4-2019

SIGNATURE GRADEING	HIGH SIGNATURE GRADEING	C.C.DIA(MM)	Ø227.56						
AREA (SQ MM)	2545.02	UNSPECIFIED THICKNESS	3±0.25	PERIMETER (MM)	878.28	STANDARD	BS EN755	SCALE	1:25
MASS (KG/M)	6.897	UNSPECIFIED CORNERS	R 0.3	SURFACE AREA	434.22	ALLOY	6063-T6	VERSION	B
			DRAWA	陈晓舒	DATE	2019-03-28	APELLATION	PAGE OF	
			STANDA-RDIZATION		DATE				
			TO SIGN	陈国提	DATE				
			AUDITING		DATE				
MARKER	MODIFY	FILE NO	SIGNATURE	DATE	APPROV	DATE			

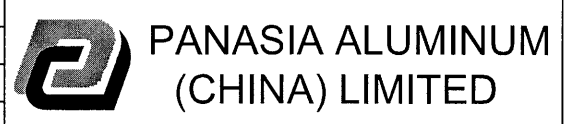

CUSTOMER	HONGKONG CO.	CUSTOMER APPROVAL	CUST PART NO.	YP-XC-LH16a
			SECTION NO.	PE0E10013(F16)

此面为外圆

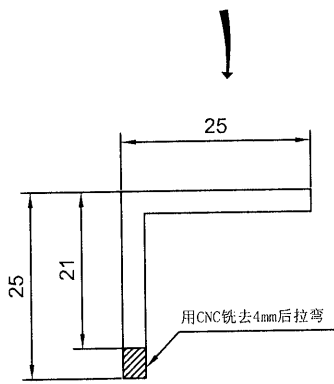

NO.V.F
SCALE 1:1

SECTION A-A

此面为内圆

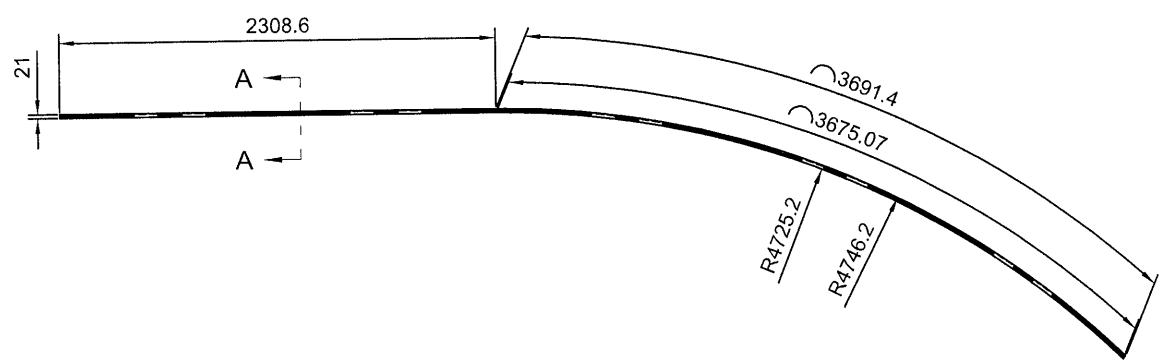

技术要求:

- 1.平面度偏差0~1.0mm;
- 2.扭拧度偏差0~5.0mm;
- 3.角度变形±1.5°;
- 4.产品未注公差±3.0mm;
- 5.允许两端各预留10mm钳口位。

Total weight: 2.289 kg/pcs
Unspecified Fabricated Tolerance: ±3.0

拉弯前展开长度: 5991.84 mm
外弧长度: 6000 mm

普特铝质有限公司	
承認圖面	印
日期	12/9-2019

SIGNATURE GRADEING	HIGH SIGNATURE GRADEING	C.C.DIA(MM)	Ø35.36						
AREA (SQ MM)	141	UNSPECIFIED THICKNESS	3±0.23	PERIMETER (MM)	100	STANDARD	BS EN755	SCALE	1:40
MASS (KG/M)	0.382	UNSPECIFIED CORNERS	R 0.3	SURFACE AREA	-	ALLOY	6063-T6	VERSION	C
		DRAWA	陈晓舒	DATE	2019-03-28	APPELLATION	-	PAGE OF	
		STANDA-RDIZATION		DATE					
		TO SIGN	陈国提	DATE					
		AUDITING		DATE					
MARKER	MODIFY	FILE NO	SIGNATURE	DATE	APPROV	DATE			

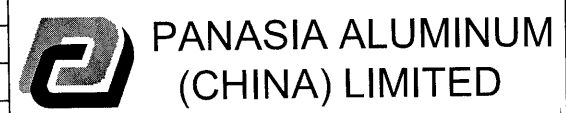

CUSTOMER	HONGKONG CO.	CUSTOMER APPROVAL	CUST PART NO.	YP-XC-LH17a
			SECTION NO.	PE0E10013(F17)

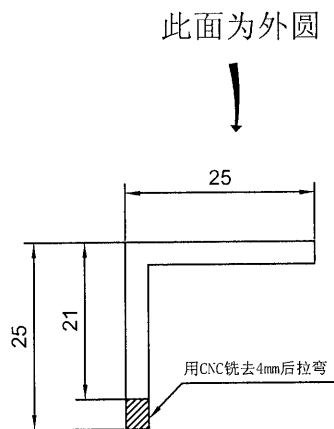

NO.V.F
SCALE 1:1

SECTION A-A

此面为内圆

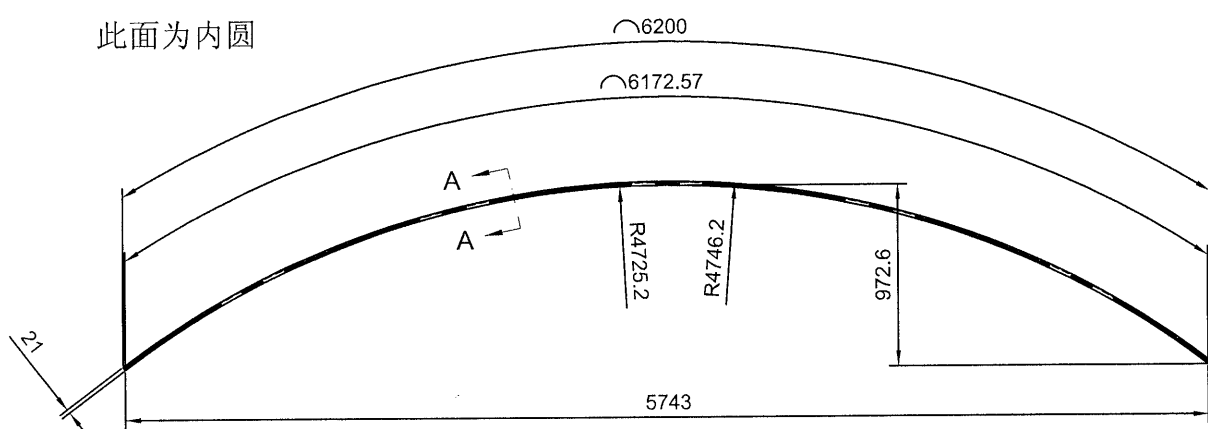

技术要求:

- 1.平面度偏差0~1.0mm;
- 2.扭拧度偏差0~5.0mm;
- 3.角度变形±1.5°;
- 4.产品未注公差±3.0mm;
- 5.允许两端各预留10mm钳口位。

Total weight:2.363 kg/pcs
Unspecified Fabricated Tolerance:±3.0

拉弯前展开长度: 6186.29 mm

外弧长度: 6200 mm

特铝有限公司	
承認圖面	6/4
日期	12/4-2019

SIGNATURE GRADE/ING	HIGH SIGNATURE GRADE/ING	C.C.DIA(MM)	Ø35.36							
AREA (SQ MM)	141	UNSPECIFIED THICKNESS	3±0.23	PERIMETER (MM)	100	STANDARD	BS EN755	SCALE	1:40	
MASS (KG/M)	0.382	UNSPECIFIED CORNERS	R 0.3	SURFACE AREA	-	ALLOY	6063-T6	VERSION	C	
				DRAWN	陈晓舒	DATE	2019-03-28	APPELLATION	-	
				STANDARDIZATION		DATE				
				TO SIGN	陈国提	DATE				
				AUDITING		DATE				
MARKER	MODIFY	FILE NO	SIGNATURE	DATE	APPROV	DATE				



CUSTOMER	HONGKONG CO.	CUSTOMER APPROVAL	CUST PART NO.	YP-XC-LH18a
			SECTION NO.	PE0E10013(F18)

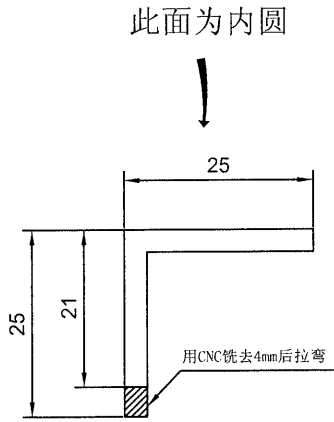

NO.V.F
SCALE 1:1

SECTION A-A

此面为外圆

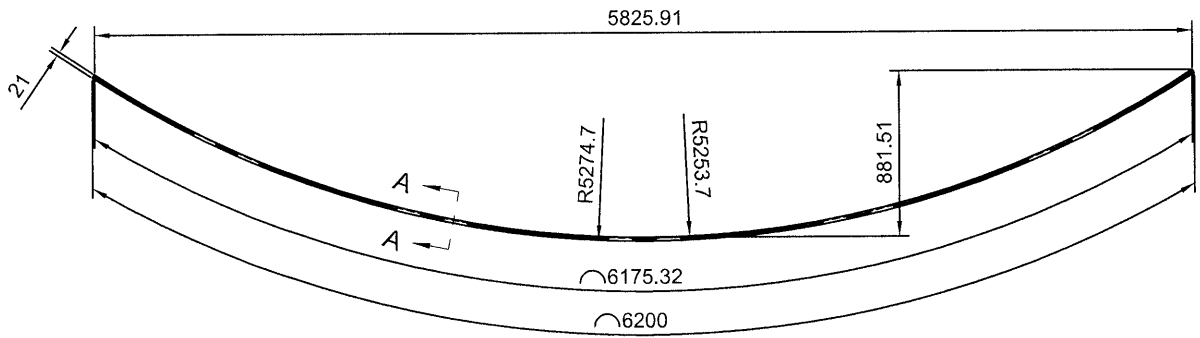

技术要求:

- 1.平面度偏差0~1.0mm;
- 2.扭拧度偏差0~5.0mm;
- 3.角度变形±1.5°;
- 4.产品未注公差±3.0mm;
- 5.允许两端各预留10mm钳口位。

Total weight:2.364 kg/pcs
Unspecified Fabricated Tolerance:±3.0

拉弯前展开长度: 6187.66 mm
外弧长度: 6200 mm

英特铝业有限公司

承認圖面

日期 12/9-2019

SIGNATURE GRADEING	HIGH SIGNATURE GRADEING	C.C.DIA(MM)	Ø35.36						
AREA (SQ MM)	141	UNSPECIFIED THICKNESS	3±0.23	PERIMETER (MM)	100	STANDARD	BS EN755	SCALE	1:40
MASS (KG/M)	0.382	UNSPECIFIED CORNERS	R 0.3	SURFACE AREA	-	ALLOY	6063-T6	VERSION	C
		DRAWN	陈晓舒	DATE	2019-03-28	APPELLATION	-	PAGE OF	
		STANDARDIZATION		DATE					
		TO SIGN	陈国提	DATE					
		AUDITING		DATE					
MARKER	MODIFY	FILE NO	SIGNATURE	DATE	APPROV				

CUSTOMER	HONGKONG CO.	CUSTOMER APPROVAL	CUST PART NO.	YP-XC-LH19a
			SECTION NO.	PE0E10013(F19)

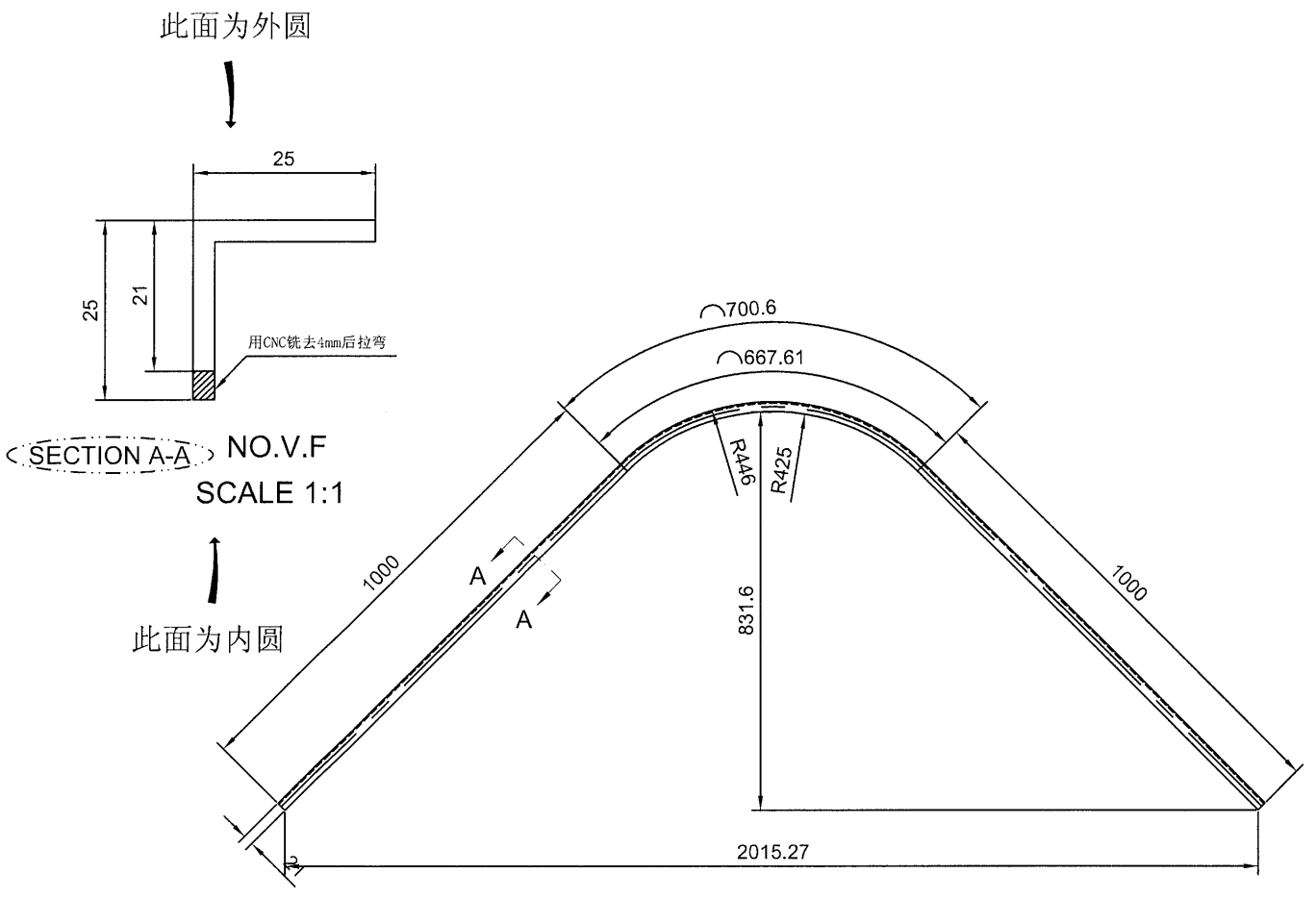

技术要求:

- 1. 平面度偏差0~1.0mm;
- 2. 扭拧度偏差0~5.0mm;
- 3. 角度变形±1.5°;
- 4. 产品未注公差±3.0mm;
- 5. 允许两端各预留10mm钳口位。

Total weight: 1.025 kg/pcs
 Unspecified Fabricated Tolerance: ±3.0

拉弯前展开长度: 2684.11 mm
 外弧长度: 2700.6 mm

普特铝业有限公司	
承认图面	仲
日期	12/9-2019

SIGNATURE GRADEING	HIGH SIGNATURE GRADEING	C.C.DIA(MM)	Ø35.36							
AREA (SQ MM)	141	UNSPECIFIED THICKNESS	3±0.23	PERIMETER (MM)	100	STANDARD	BS EN755	SCALE	1:15	
MASS (KG/M)	0.382	UNSPECIFIED CORNERS	R 0.3	SURFACE AREA	-	ALLOY	6063-T6	VERSION	C	
-		-		DRAWN	陈晓舒	DATE	2019-03-28	APELLATION	-	PAGE OF
				STANDARDIZATION		DATE				
				TO SIGN	陈国提	DATE				
				AUDITING		DATE				
MARKER	MODIFY	FILE NO	SIGNATURE	DATE	APPROV	DATE				

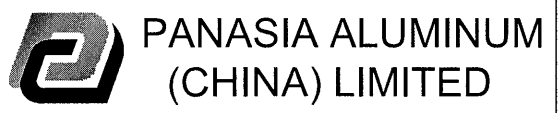

CUSTOMER	HONGKONG CO.	CUSTOMER APPROVAL	CUST PART NO.	YP-XC-LH20a
			SECTION NO.	PE0E10013(F20)

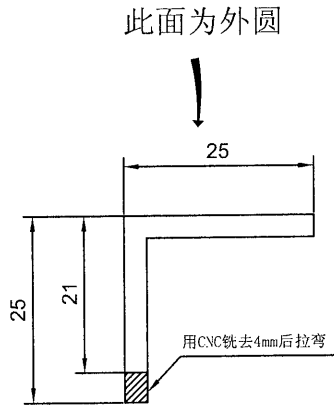

NO.V.F
SCALE 1:1

SECTION A-A

此面为内圆

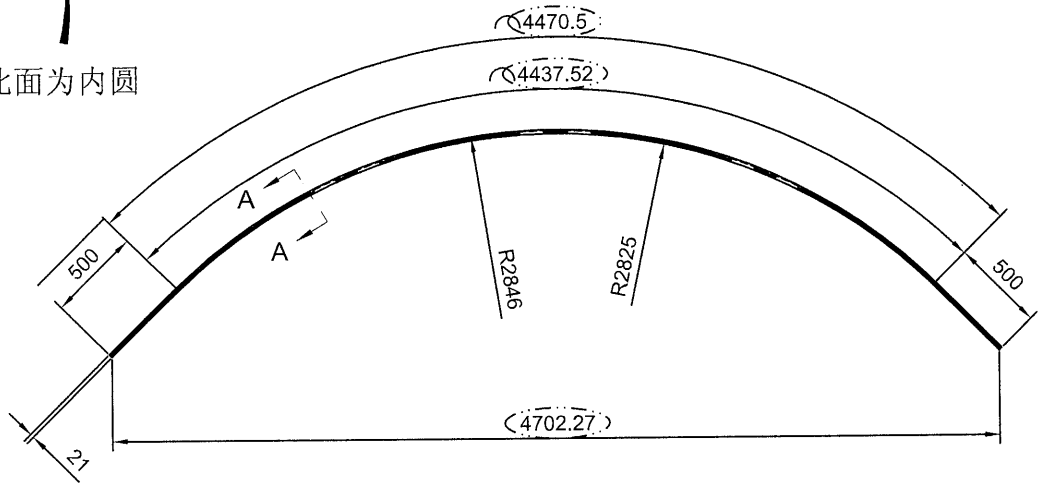

技术要求:

- 1.平面度偏差0~1.0mm;
- 2.扭拧度偏差0~5.0mm;
- 3.角度变形±1.5°;
- 4.产品未注公差±3.0mm;
- 5.允许两端各预留10mm钳口位。

Total weight: 2.083kg/pcs
Unspecified Fabricated Tolerance: ±3.0

拉弯前展开长度: 5454.01mm

外弧长度: 5470.5mm

美特铝业有限公司	
承認圖面	<i>[Signature]</i>
日期	12/4-2019

SIGNATURE GRADEING	HIGH SIGNATURE GRADEING	C.C.DIA(MM)	Ø35.36						
AREA (SQ MM)	141	UNSPECIFIED THICKNESS	3±0.23	PERIMETER (MM)	100	STANDARD	BS EN755	SCALE	1:40
MASS (KG/M)	0.382	UNSPECIFIED CORNERS	R 0.3	SURFACE AREA	-	ALLOY	6063-T6	VERSION	C
		DRAWA	陈晓舒	DATE	2019-03-28	APPELLATION	-	PAGE OF	
		STANDA-RDIZATION		DATE					
		TO SIGN	陈国提	DATE					
		AUDITING		DATE					
MARKER	MODIFY	FILE NO	SIGNATURE	DATE	APPROV	DATE			

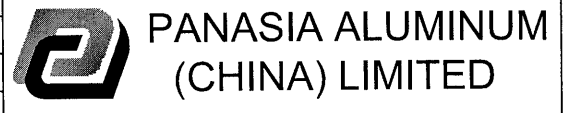

CUSTOMER	HONGKONG CO.	CUSTOMER APPROVAL	CUST PART NO.	YP-XC-LH21a
			SECTION NO.	PE0E10013(F21)

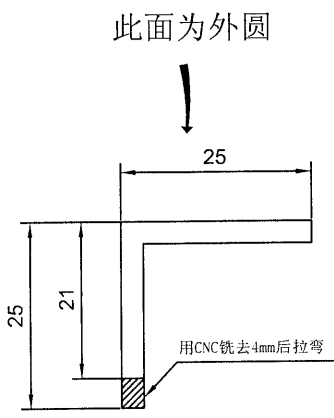

NO.V.F
SCALE 1:1

SECTION A-A

此面为内圆

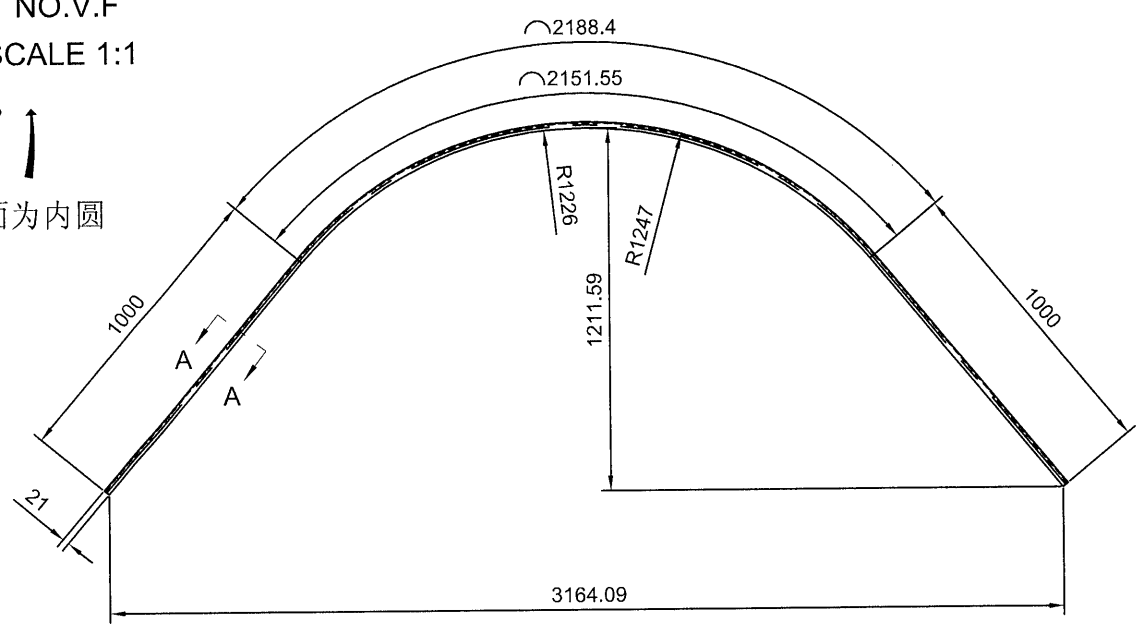

技术要求:

- 1.平面度偏差0~1.0mm;
- 2.扭拧度偏差0~5.0mm;
- 3.角度变形±1.5°;
- 4.产品未注公差±3.0mm;
- 5.允许两端各预留10mm钳口位。

Total weight: 1.593 kg/pcs
Unspecified Fabricated Tolerance: ±3.0

拉弯前展开长度: 4169.98 mm

外弧长度: 4188.4 mm

美特铝业公司

承認圖面	仲
日期	2/4-2019

SIGNATURE GRADEING	HIGH SIGNATURE GRADEING	C.C.DIA(MM)	Ø35.36						
AREA (SQ MM)	141	UNSPECIFIED THICKNESS	3±0.23	PERIMETER (MM)	100	STANDARD	BS EN755	SCALE	1:25
MASS (KG/M)	0.382	UNSPECIFIED CORNERS	R 0.3	SURFACE AREA	-	ALLOY	6063-T6	VERSION	C
		DRAWA	陈晓舒	DATE	2019-03-28	APPELLATION	PAGE OF		
		STANDA-RDIZATION		DATE					
		TO SIGN	陈国提	DATE					
		AUDITING		DATE					
MARKER	MODIFY	FILE NO	SIGNATURE	DATE	APPROV	DATE			

