

工程指示 / 要求簡箋(E.I.)

工程指示編號：EI/ 9866 /18 修改版次：

工程編號：J836 工程名稱：日出康城7期平台

工程項目：確認拉彎料圖紙

收件人：Maggie Lor, 生統 發件人：Joe Chan

日期：24/10/2018

要求提供 / 確認 事項：

- | | | |
|------------------------------------|-------------------------------------|-------------------------------|
| <input type="checkbox"/> 初步鋁料 B.M. | <input type="checkbox"/> 加工拆圖，然後生產 | <input type="checkbox"/> 尺寸表 |
| <input type="checkbox"/> 正式鋁料 B.M. | <input type="checkbox"/> 技術上資料 / 指示 | <input type="checkbox"/> 報價 |
| <input type="checkbox"/> 配件 B.M. | <input type="checkbox"/> 樣辦或貨品說明書 | <input type="checkbox"/> 分判合約 |
| <input type="checkbox"/> 其他：_____ | | |

內容：確認拉彎料圖紙 13 張。

請在 _____ 前完成上列要求。

附有關圖紙 / 文件：

13 頁

以上項目為：

- 原合約工程包 原合約工程加 / 減賬 新工程報價

原因：-

分發東莞各部門：

- () 生產技術總監 連附件 () 技術部 連附件 () 生產部 連附件 () 機械設計部 連附件
 () 採購部 連附件 (✓) 生產統籌部 連附件 梅軍
 () 質檢部 連附件 () 會計部 連附件 () 報關組 連附件 () 其他 _____ 連附件

分發香港各部門：

- () 行政部 連附件 () 會計部 連附件 () 統籌部 連附件 () 工程部地盤科文 連附件
 () 採購部 連附件 () QS 部 連附件 () 維修部 連附件 () 其他 _____ 連附件

傳遞編號：

HK 1620/18

發件人簽署：

FL

項目經理簽署：

[Signature]

①

CUSTOMER	HONGKONG CO.	CUSTOMER APPROVAL	CUST PART NO.	J836-SK-WH03
			SECTION NO.	LH0079491(F02)

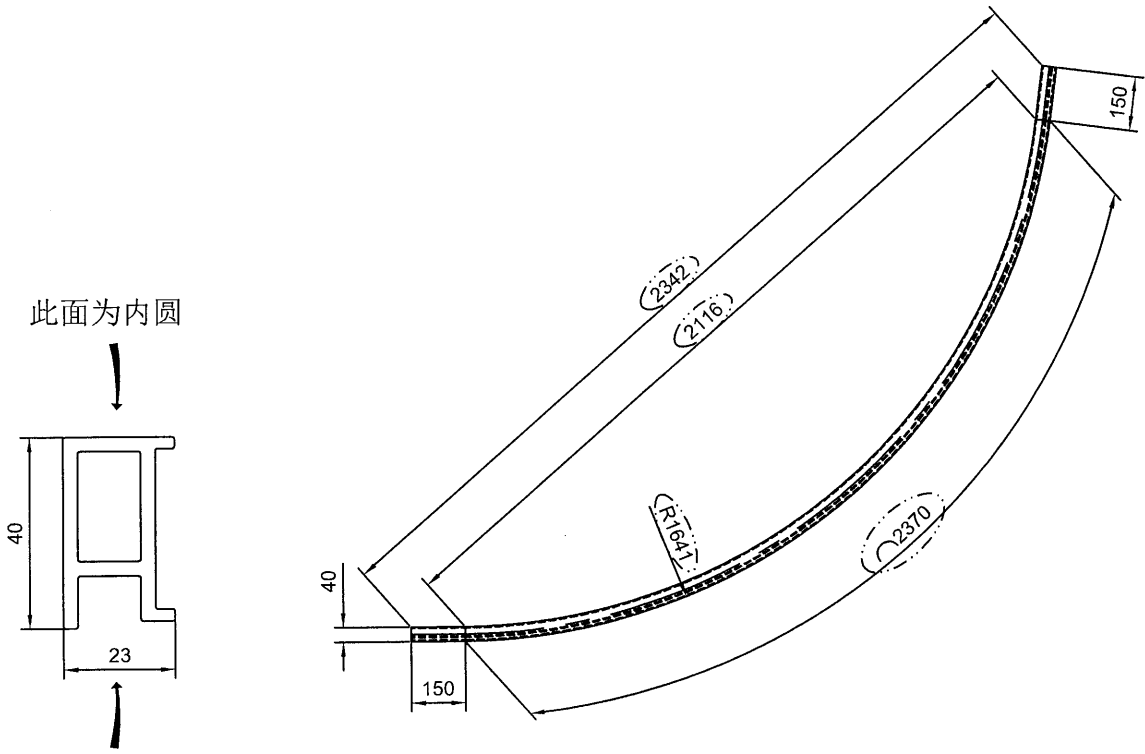

此面为内圆
 ↓
 40
 23
 ↑
 此面为外圆
 SCALE 1:1.5

拉弯前展开长度: (2641.12 mm)
 外弧长度: (2670 mm)

- 技术要求:
1. 平面度偏差0~1.0mm;
 2. 扭拧度偏差0~5.0mm;
 3. 角度变形±1.5°;
 4. 产品未注公差±3.0mm;
 5. 允许两端各预留10mm钳口位。

美特铝质有限公司	
承認圖面	
日期	

Total weight: (2.388 kg/pcs)
 Unspecified Fabricated Tolerance: ±3.0

SIGNATURE GRADEING	HIGH SIGNATURE GRADEING	C.C.DIA(MM)	Ø 45.78							
AREA (SQ MM)	333.50	UNSPECIFIED THICKNESS	-	PERIMETER (MM)	150.42	STANDARD	BS EN755	SCALE	1:20	
MASS (KG/M)	0.904	UNSPECIFIED CORNERS	R0.5	SURFACE AREA	61.50	ALLOY	6063-T5	VERSION	B	
				DRAWN	蔡晓婷	DATE	2018-10-19	APPELLATION	-	
				STANDARDIZATION		DATE				
				TO SIGN	陈国提	DATE				
				AUDITING		DATE				
MARKER	MODIFY	FILE NO	SIGNATURE	DATE	APPROV	DATE				

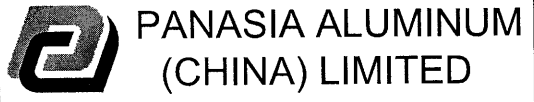

2

CUSTOMER	HONGKONG CO.	CUSTOMER APPROVAL	CUST PART NO.	J836-SK-WH04
			SECTION NO.	LH0079491(F03)

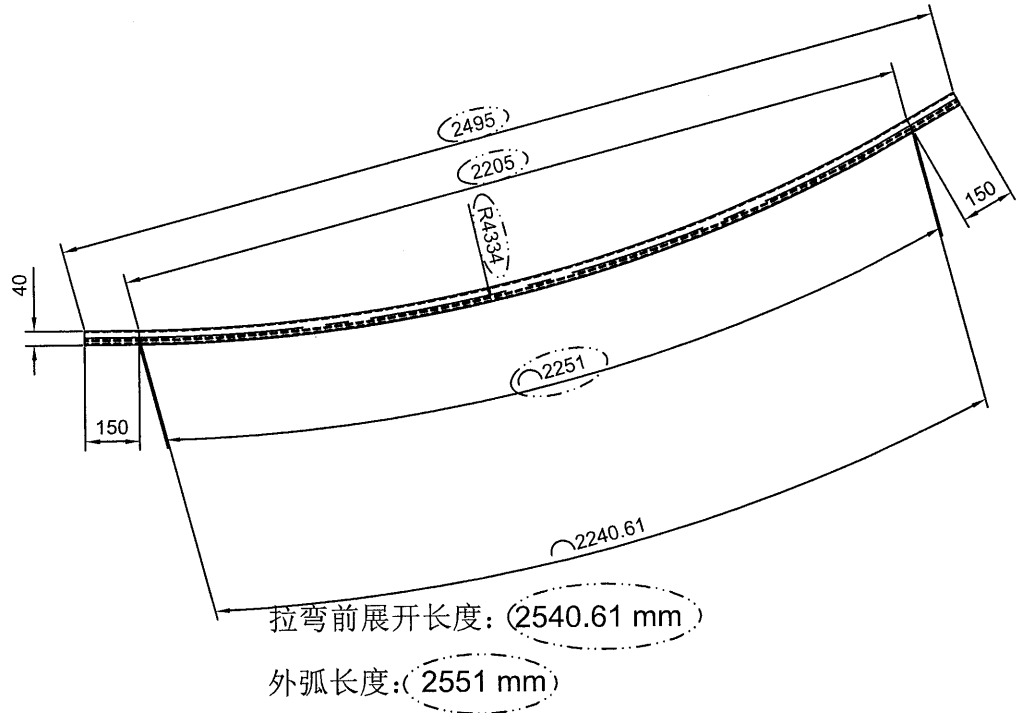
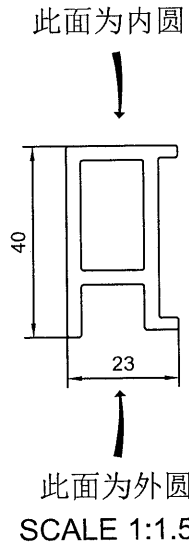

技术要求:

1. 平面度偏差0~1.0mm;
2. 扭拧度偏差0~5.0mm;
3. 角度变形±1.5°;
4. 产品未注公差±3.0mm;
5. 允许两端各预留10mm钳口位。

Total weight: (2.297 kg/pcs)

Unspecified Fabricated Tolerance: ±3.0

美特铝质有限公司	
認圖面	
日期	

SIGNATURE GRADEING	HIGH SIGNATURE GRADEING	C.C.DIA(MM)	Ø 45.78						
AREA (SQ MM)	333.50	UNSPECIFIED THICKNESS	-	PERIMETER (MM)	150.42	STANDARD	BS EN755	SCALE	1:20
MASS (KG/M)	0.904	UNSPECIFIED CORNERS	R0.5	SURFACE AREA	61.50	ALLOY	6063-T5	VERSION	B
				DRAWN	蔡晓婷	DATE	2018-10-18	PAGE OF	
				STANDARDIZATION		DATE			
				TO SIGN	陈国提	DATE			
				AUDITING		DATE			
MARKER	MODIFY	FILE NO	SIGNATURE	DATE	APPROV	DATE			



3

CUSTOMER	HONGKONG CO.	CUSTOMER APPROVAL	CUST PART NO.	J836-SK-WH05
			SECTION NO.	LH0079491(F04)

此面为内圆

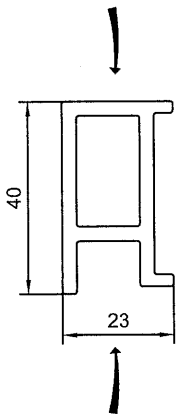

此面为外圆
SCALE 1:1.5

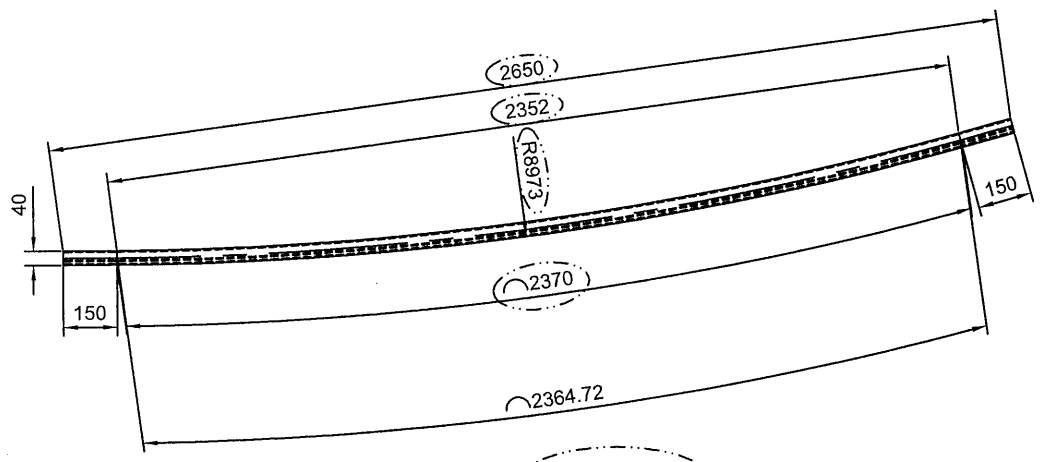

拉弯前展开长度: (2664.72 mm)
外弧长度: (2670 mm)

技术要求:

1. 平面度偏差0~1.0mm;
2. 扭拧度偏差0~5.0mm;
3. 角度变形±1.5°;
4. 产品未注公差±3.0mm;
5. 允许两端各预留10mm钳口位。

美特铝质有限公司	
承認圖面	
日期	

Total weight: (2.410 kg/pcs)
Unspecified Fabricated Tolerance: ±3.0

SIGNATURE GRADEING	HIGH SIGNATURE GRADEING	C.C.DIA(MM)	Ø 45.78							
AREA (SQ MM)	333.50	UNSPECIFIED THICKNESS	-	PERIMETER (MM)	150.42	STANDARD	BS EN755	SCALE	1:20	
MASS (KG/M)	0.904	UNSPECIFIED CORNERS	R0.5	SURFACE AREA	61.50	ALLOY	6063-T5	VERSION	B	
				DRAWN	蔡晓婷	DATE	2018-10-18	APPELLATION	-	
				STANDARDIZATION		DATE		PAGE OF		
				TO SIGN	陈国提	DATE				
				AUDITING		DATE				
MARKER	MODIFY	FILE NO	SIGNATURE	DATE	APPROV	DATE				

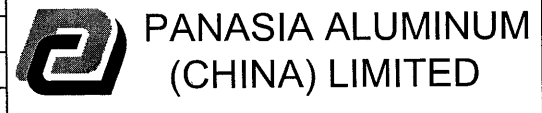

4

CUSTOMER	HONGKONG CO.	CUSTOMER APPROVAL	CUST PART NO.	J836-SK-WH06
			SECTION NO.	LH0079491(F05)

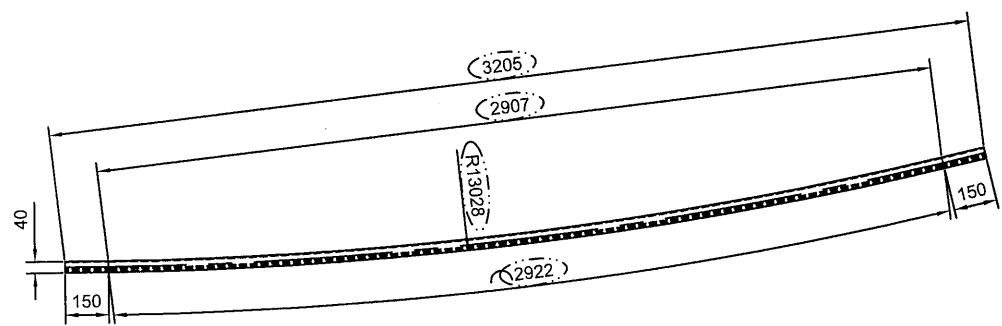
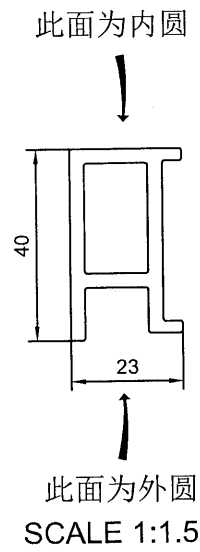

拉弯前展开长度: (3217.52mm)

外弧长度: (3222 mm)

- 技术要求:
- 1.平面度偏差0~1.0mm;
 - 2.扭拧度偏差0~5.0mm;
 - 3.角度变形±1.5°;
 - 4.产品未注公差±3.0mm;
 - 5.允许两端各预留10mm钳口位。

美特铝质有限公司	
承認圖面	
日期	

Total weight: 2.909 kg/pcs

Unspecified Fabricated Tolerance: ±3.0

SIGNATURE GRADEING	HIGH SIGNATURE GRADEING	C.C.DIA(MM)	Ø 45.78							
AREA (SQ MM)	333.50	UNSPECIFIED THICKNESS	-	PERIMETER (MM)	150.42	STANDARD	BS EN755	SCALE	1:25	
MASS (KG/M)	0.904	UNSPECIFIED CORNERS	R0.5	SURFACE AREA	61.50	ALLOY	6063-T5	VERSION	B	
-			DRAWN	蔡晓婷	DATE	2018-10-18	APPELLATION	-	PAGE OF	
			STANDARDIZATION		DATE					
			TO SIGN	陈国提	DATE					
			AUDITING		DATE					
MARKER	MODIFY	FILE NO	SIGNATURE	DATE	APPROV	DATE				

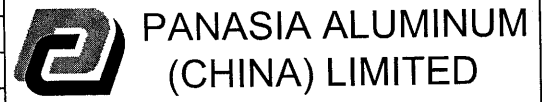

5

CUSTOMER	HONGKONG CO.	CUSTOMER APPROVAL	CUST PART NO.	J836-SK-WH10
			SECTION NO.	PM0000431(F10)

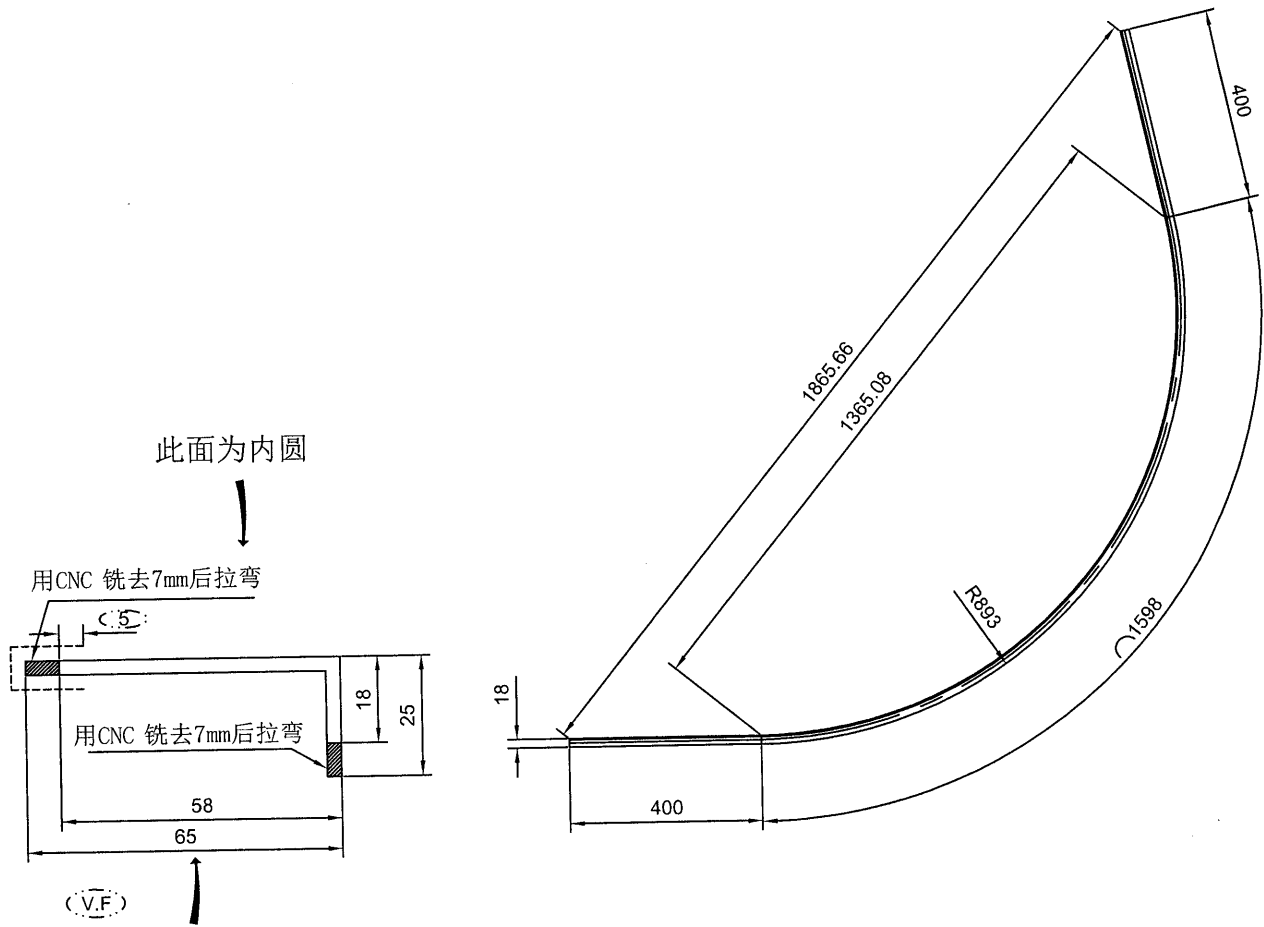

此面为内圆

用CNC 铣去7mm后拉弯

用CNC 铣去7mm后拉弯

此面为外圆

SCALE 1:1.5

拉弯前展开长度: 2381.9 mm

外弧长度: 2398 mm

技术要求:

1. 平面度偏差0~1.0mm;
2. 扭拧度偏差0~5.0mm;
3. 角度变形±1.5°;
4. 产品未注公差±3.0mm;
5. 允许两端各预留10mm钳口位。

Total weight: 1.684 kg/pcs

Unspecified Fabricated Tolerance: ±3.0

美特铝质有限公司	
承認圖面	
日期	

SIGNATURE GRADEING	HIGH SIGNATURE GRADEING	C.C.DIA(MM)	Ø69.64						
AREA (SQ MM)	261	UNSPECIFIED THICKNESS	3±0.25	PERIMETER (MM)	180	STANDARD	BS EN755	SCALE	1:15
MASS (KG/M)	0.707	UNSPECIFIED CORNERS	R 0.3	SURFACE AREA	27	ALLOY	6063-T5	VERSION	B
COMPANY ISSUE		A	DRAWN	蔡晓婷	DATE	2018-10-20	APPELLATION	-	PAGE OF
			STANDARDIZATION		DATE				
			TO SIGN	陈国提	DATE				
			AUDITING		DATE				
MARKER	MODIFY	FILE NO	SIGNATURE	DATE	APPROV	DATE			

PANSIA ALUMINUM (CHINA) LIMITED

6

CUSTOMER	HONGKONG CO.	CUSTOMER APPROVAL		CUST PART NO.	J836-SK-WH12
				SECTION NO.	PM0000431(F11)

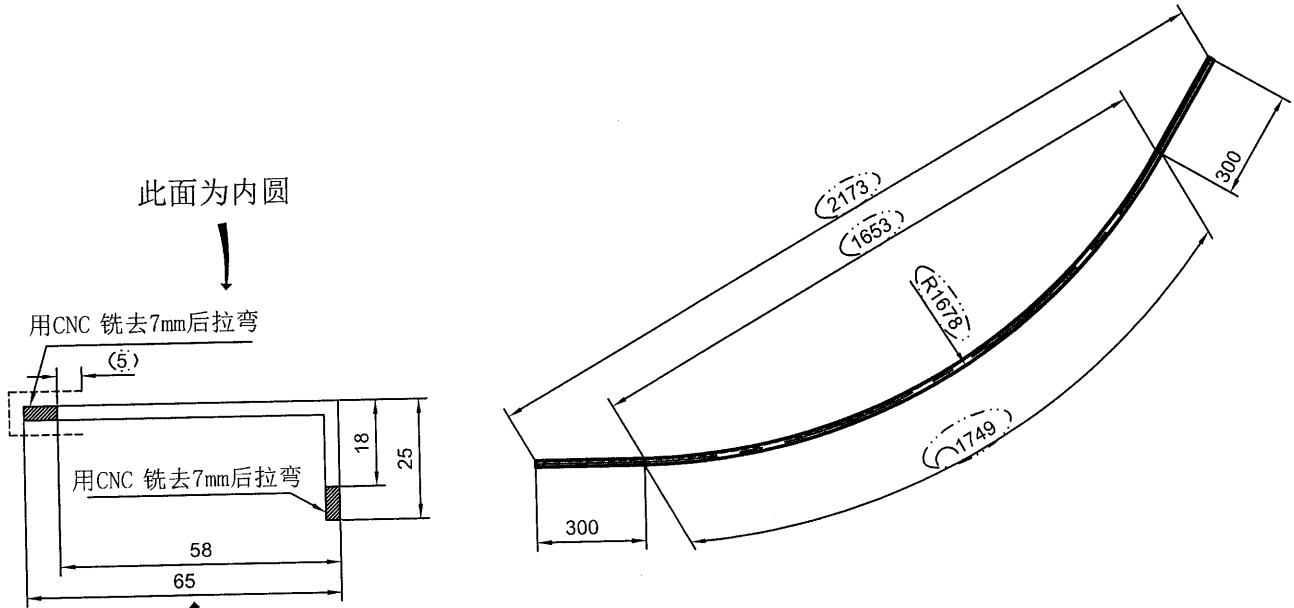

此面为内圆



用CNC 铣去7mm后拉弯

用CNC 铣去7mm后拉弯

(VF)

此面为外圆

SCALE 1:1.5

拉弯前展开长度: 2339.62 mm

外弧长度: 2349mm

技术要求:

- 1.平面度偏差0~1.0mm;
- 2.扭拧度偏差0~5.0mm;
- 3.角度变形±1.5°;
- 4.产品未注公差±3.0mm;
- 5.允许两端各预留10mm钳口位。

Total weight: 1.654 kg/pcs

Unspecified Fabricated Tolerance: ±3.0

美特铝质有限公司	
承認圖面	
日期	

SIGNATURE GRADEING	HIGH SIGNATURE GRADEING	C.C.DIA(MM)	Ø69.64							
AREA (SQ MM)	261	UNSPECIFIED THICKNESS	3±0.25	PERIMETER (MM)	180	STANDARD	BS EN755	SCALE	1:20	
MASS (KG/M)	0.707	UNSPECIFIED CORNERS	R 0.3	SURFACE AREA	27	ALLOY	6063-T5	VERSION	B	
				DRAWA	陈晓舒	DATE	2018-10-07	APELLATION	PAGE OF	
				STANDA-RDIZATION		DATE				
				TO SIGN	陈国提	DATE				
				AUDITING		DATE				
MARKER	MODIFY	FILE NO	SIGNATURE	DATE	APPROV	DATE				



PANASIA ALUMINUM (CHINA) LIMITED

7

CUSTOMER	HONGKONG CO.	CUSTOMER APPROVAL	CUST PART NO.	J836-SK-WH13
			SECTION NO.	PM0000431(F12)

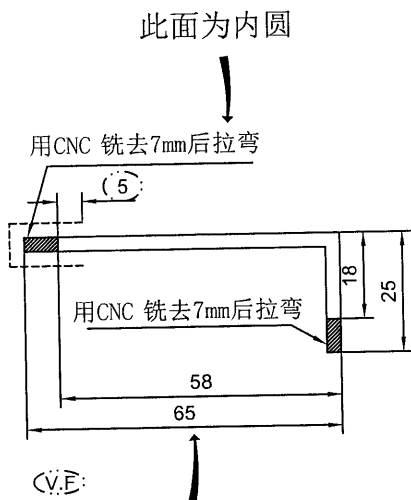

此面为外圆
SCALE 1:1.5

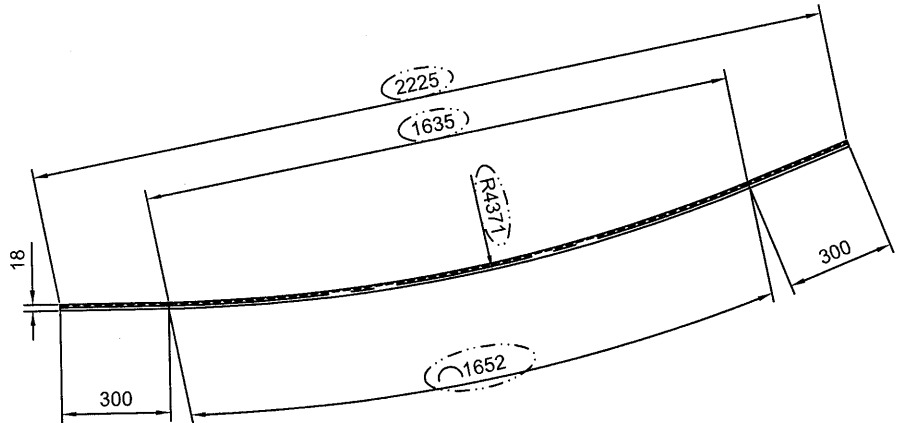

拉弯前展开长度: (2248.6mm)

外弧长度: (2252mm)

技术要求:

1. 平面度偏差0~1.0mm;
2. 扭拧度偏差0~5.0mm;
3. 角度变形±1.5°;
4. 产品未注公差±3.0mm;
5. 允许两端各预留10mm钳口位。

Total weight: (1.590kg/pcs)
Unspecified Fabricated Tolerance: ±3.0

美特铝质有限公司	
承認圖面	
日期	

SIGNATURE GRADEING	HIGH SIGNATURE GRADEING	C.C.DIA(MM)	Ø69.64						
AREA (SQ MM)	261	UNSPECIFIED THICKNESS	3±0.25	PERIMETER (MM)	180	STANDARD	BS EN755	SCALE	1:20
MASS (KG/M)	0.707	UNSPECIFIED CORNERS	R 0.3	SURFACE AREA	(27)	ALLOY	6063-T5	VERSION	B
		DRAWA	陈晓舒	DATE	2018-10-18	APPELLATION	-	PAGE OF	
		STANDARDIZATION		DATE					
		TO SIGN	陈国提	DATE					
		AUDITING		DATE					
MARKER	MODIFY	FILE NO	SIGNATURE	DATE	APPROV	DATE			

⑧

CUSTOMER	HONGKONG CO.	CUSTOMER APPROVAL	CUST PART NO.	J836-SK-WH14
			SECTION NO.	PM0000431(F13)

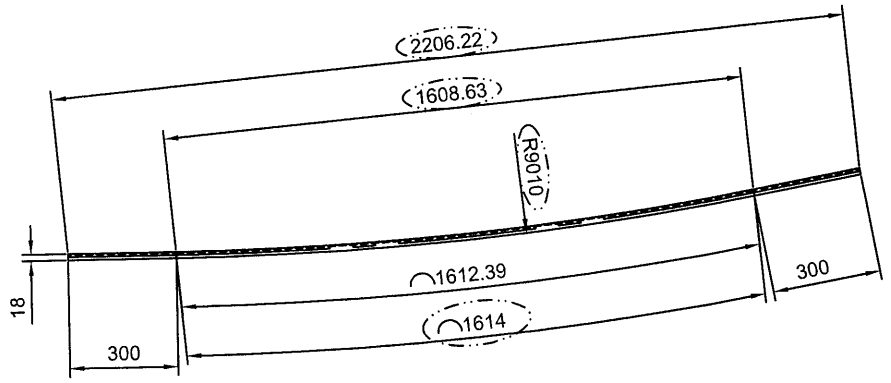
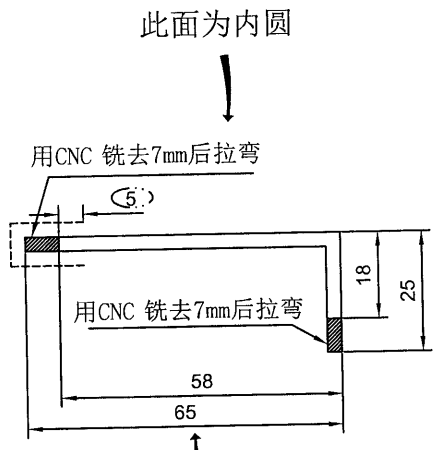

(V.F.)
此面为外圆
SCALE 1:1.5

拉弯前展开长度: (2212.39 mm)

外弧长度: (2214 mm)

- 技术要求:
- 1.平面度偏差0~1.0mm;
 - 2.扭拧度偏差0~5.0mm;
 - 3.角度变形±1.5°;
 - 4.产品未注公差±3.0mm;
 - 5.允许两端各预留10mm钳口位。

Total weight: (1.564kg/pcs)
Unspecified Fabricated Tolerance: ±3.0

美特铝质有限公司	
承認圖面	
日期	

SIGNATURE GRADEING	HIGH SIGNATURE GRADEING	C.C.DIA(MM)	Ø69.64						
AREA (SQ MM)	261	UNSPECIFIED THICKNESS	3±0.25	PERIMETER (MM)	180	STANDARD	BS EN755	SCALE	1:20
MASS (KG/M)	0.707	UNSPECIFIED CORNERS	R 0.3	SURFACE AREA	(27)	ALLOY	6063-T5	VERSION	B
		DRAWA	陈晓舒	DATE	2018-10-07	APELLATION	-	PAGE OF	
		STANDA-RDIZATION		DATE					
		TO SIGN	陈国提	DATE					
		AUDITING		DATE					
MARKER	MODIFY	FILE NO	SIGNATURE	DATE	APPROV	DATE			

9

CUSTOMER	HONGKONG CO.	CUSTOMER APPROVAL	CUST PART NO.	J836-SK-WH15
			SECTION NO.	PM0000431(F14)

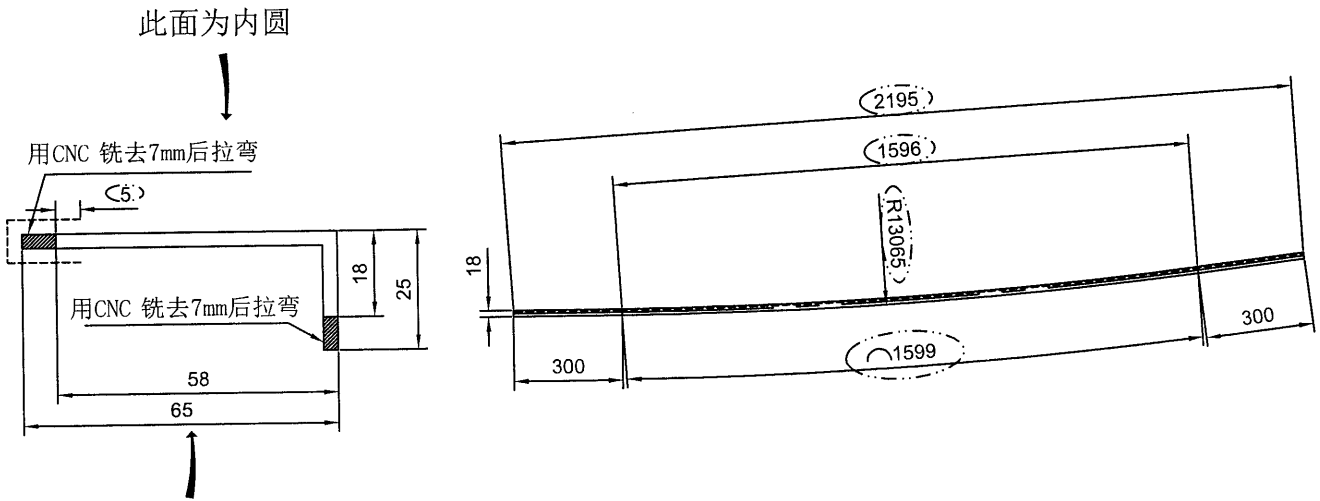

此面为内圆

(V.F) 此面为外圆
SCALE 1:1.5

拉弯前展开长度: (2197.9 mm)
外弧长度: 2199 mm

技术要求:

1. 平面度偏差0~1.0mm;
2. 扭拧度偏差0~5.0mm;
3. 角度变形±1.5°;
4. 产品未注公差±3.0mm;
5. 允许两端各预留10mm钳口位。

Total weight: 1.554 kg/pcs
Unspecified Fabricated Tolerance: ±3.0

特铝质有限公司	
承认图面	
日期	

SIGNATURE GRADEING	HIGH SIGNATURE GRADEING	C.C.DIA(MM)	Ø69.64						
AREA (SQ MM)	261	UNSPECIFIED THICKNESS	3±0.25	PERIMETER (MM)	180	STANDARD	BS EN755	SCALE	1:20
MASS (KG/M)	0.707	UNSPECIFIED CORNERS	R 0.3	SURFACE AREA	(27)	ALLOY	6063-T5	VERSION	B
		DRAWN	蔡晓婷	DATE	2018-10-18	APPELLATION	-	PAGE OF	
		STANDARDIZATION		DATE					
		TO SIGN	陈国提	DATE					
		AUDITING		DATE					
MARKER	MODIFY FILE NO	SIGNATURE	DATE	APPROV	DATE				

10

CUSTOMER	HONGKONG CO.	CUSTOMER APPROVAL	CUST PART NO.	J836-SK-WH21
			SECTION NO.	ME0000168(F02)

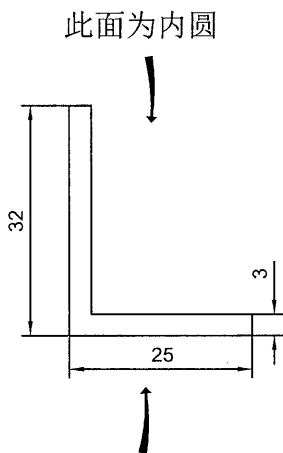

此面为外圆
SCALE 1:1

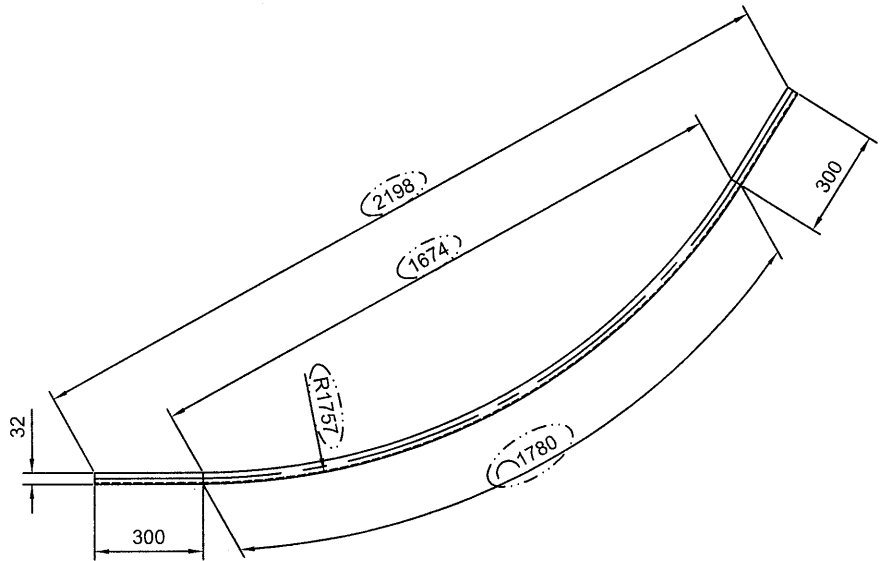

拉弯前展开长度: (2363.79 mm)

外弧长度: (2380 mm)

技术要求:

1. 平面度偏差0~1.0mm;
2. 扭拧度偏差0~5.0mm;
3. 角度变形±1.5°;
4. 产品未注公差±3.0mm;
5. 允许两端各预留10mm钳口位。

Total weight: (1.038 kg/pcs)

Unspecified Fabricated Tolerance: ±3.0

美特铝质有限公司	
大 图 面	
日 期	

SIGNATURE GRADEING	HIGH SIGNATURE GRADEING	C.C.DIA(MM)	Ø40.61						
AREA (SQ MM)	162.00	UNSPECIFIED THICKNESS	3±0.25	PERIMETER (MM)	114.00	STANDARD	BS EN755	SCALE	1:20
MASS (KG/M)	0.439	UNSPECIFIED CORNERS	R 0.3	SURFACE AREA	-	ALLOY	6063-T5	VERSION	B
		DRAWA	蔡晓婷	DATE	2018-10-18	APELLATION	-	PAGE OF	
		STANDA-RDIZATION		DATE					
		TO SIGN	陈国提	DATE					
		AUDITING		DATE					
MARKER	MODIFY	FILE NO	SIGNATURE	DATE	APPROV				

11

CUSTOMER	HONGKONG CO.	CUSTOMER APPROVAL	CUST PART NO.	J836-SK-WH22
			SECTION NO.	ME0000168(F03)

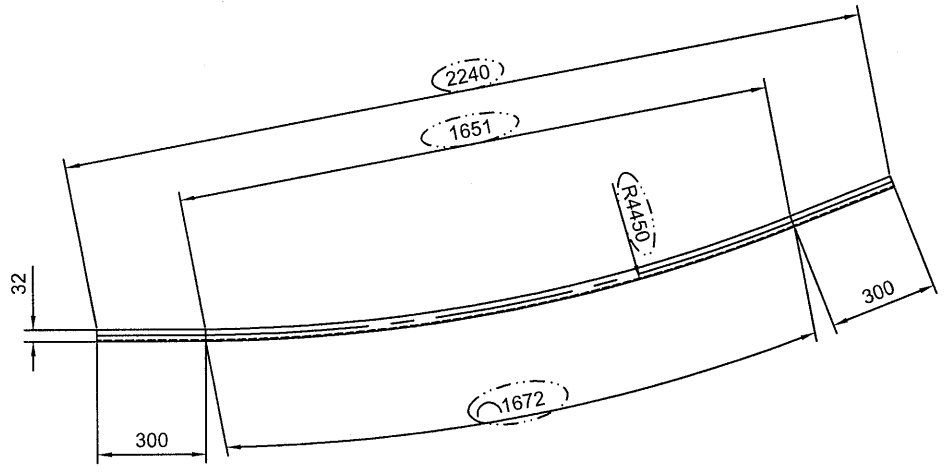
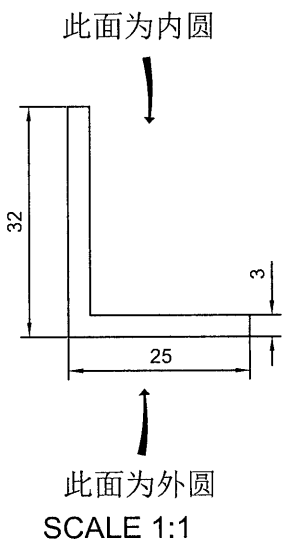

拉弯前展开长度: $\varnothing 2265.99 \text{ mm}$

外弧长度: $\varnothing 2272 \text{ mm}$

技术要求:

1. 平面度偏差0~1.0mm;
2. 扭拧度偏差0~5.0mm;
3. 角度变形 $\pm 1.5^\circ$;
4. 产品未注公差 $\pm 3.0 \text{ mm}$;
5. 允许两端各预留10mm钳口位。

Total weight: $\varnothing 0.995 \text{ kg/pcs}$
 Unspecified Fabricated Tolerance: ± 3.0

美特铝质有限公司	
承認圖面	
日期	

SIGNATURE GRADEING	HIGH SIGNATURE GRADEING	C.C.DIA(MM)	$\varnothing 40.61$							
AREA (SQ MM)	162.00	UNSPECIFIED THICKNESS	3 ± 0.25	PERIMETER (MM)	114.00	STANDARD	BS EN755	SCALE	1:20	
MASS (KG/M)	0.439	UNSPECIFIED CORNERS	R 0.3	SURFACE AREA	-	ALLOY	6063-T5	VERSION	B	
				DRAWN	陈晓舒	DATE	2018-10-07	APPELLATION	-	
				STANDARDIZATION		DATE				
				TO SIGN	陈国提	DATE				
				AUDITING		DATE				
MARKER	MODIFY	FILE NO	SIGNATURE	DATE	APPROV	DATE				

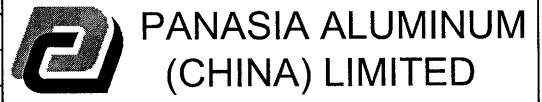

12

CUSTOMER	HONGKONG CO.	CUSTOMER APPROVAL	CUST PART NO.	J836-SK-WH23
			SECTION NO.	ME0000168(F04)

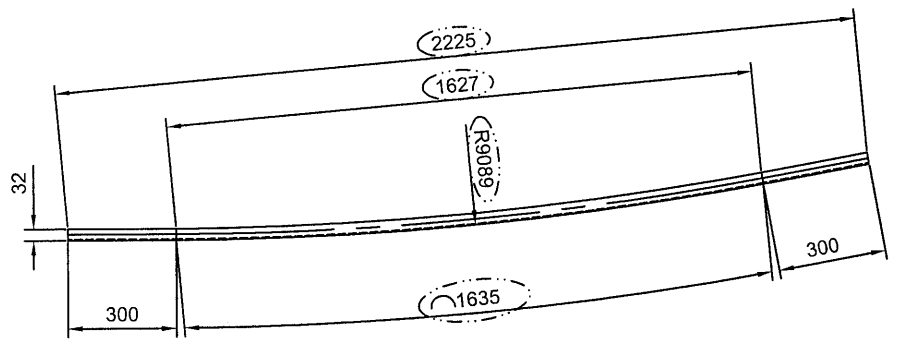
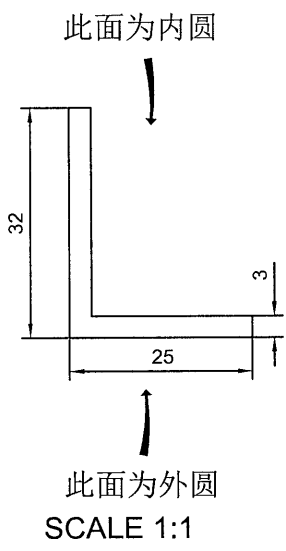

拉弯前展开长度: (2232.12 mm)

外弧长度: (2235 mm)

技术要求:

1. 平面度偏差0~1.0mm;
2. 扭拧度偏差0~5.0mm;
3. 角度变形±1.5°;
4. 产品未注公差±3.0mm;
5. 允许两端各预留10mm钳口位。

Total weight: 0.980 kg/pcs
 Unspecified Fabricated Tolerance: ±3.0

美特铝质有限公司	
承認圖面	
日期	

SIGNATURE GRADEING	HIGH SIGNATURE GRADEING	C.C.DIA(MM)	Ø40.61								
AREA (SQ MM)	162.00	UNSPECIFIED THICKNESS	3±0.25	PERIMETER (MM)	114.00	STANDARD	BS EN755	SCALE	1:20		
MASS (KG/M)	0.439	UNSPECIFIED CORNERS	R 0.3	SURFACE AREA	-	ALLOY	6063-T5	VERSION	B		
		DRAWN	陈晓舒	DATE	2018-10-07	APPELLATION	-	PAGE OF			
		STANDARDIZATION		DATE							
		TO SIGN	陈国提	DATE							
		AUDITING		DATE							
MARKER	MODIFY	FILE NO	SIGNATURE	DATE	APPROV	DATE					

13

CUSTOMER	HONGKONG CO.	CUSTOMER APPROVAL	CUST PART NO.	J836-SK-WH24
			SECTION NO.	ME0000168(F05)

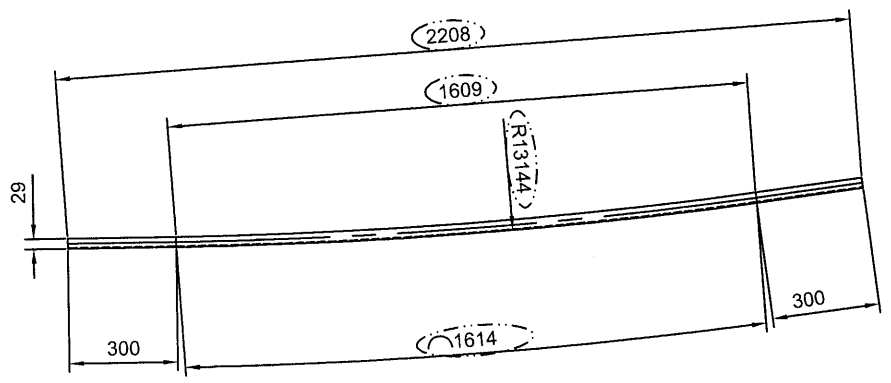
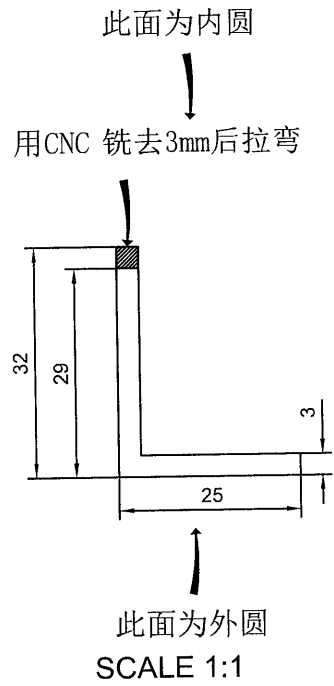

拉弯前展开长度: (2212.22 mm)

外弧长度: (2214 mm)

- 技术要求:
- 1.平面度偏差0~1.0mm;
 - 2.扭拧度偏差0~5.0mm;
 - 3.角度变形±1.5°;
 - 4.产品未注公差±3.0mm;
 - 5.允许两端各预留10mm钳口位。

Total weight: 0.971 kg/pcs
 Unspecified Fabricated Tolerance:±3.0

美特鋁質有限公司	
承認圖面	
日期	

SIGNATURE GRADEING	HIGH SIGNATURE GRADEING	C.C.DIA(MM)	Ø40.61						
AREA (SQ MM)	162.00	UNSPECIFIED THICKNESS	3±0.25	PERIMETER (MM)	114.00	STANDARD	BS EN755	SCALE	1:20
MASS (KG/M)	0.439	UNSPECIFIED CORNERS	R 0.3	SURFACE AREA	-	ALLOY	6063-T5	VERSION	B
		DRAWA	陈晓舒	DATE	2018-10-07	APELLATION	-	PAGE OF	
		STANDA-RDIZATION		DATE					
		TO SIGN	陈国提	DATE					
		AUDITING		DATE					
MARKER	MODIFY	FILE NO	SIGNATURE	DATE	APPROV	DATE			

