

工程指示 / 要求簡箋(E.I.)

工程指示編號：EI/ 9395 /18 修改版次：
 工程編號：J836 工程名稱：日出康城7期平台
 工程項目：確認模圖共17個(WW2)
 收件人：Maggie Lor 發件人：李權鵬 日期：2018/5/30

要求提供 / 確認 事項：

- | | | |
|------------------------------------|-------------------------------------|-------------------------------|
| <input type="checkbox"/> 初步鋁料 B.M. | <input type="checkbox"/> 加工拆圖，然後生產 | <input type="checkbox"/> 尺寸表 |
| <input type="checkbox"/> 正式鋁料 B.M. | <input type="checkbox"/> 技術上資料 / 指示 | <input type="checkbox"/> 報價 |
| <input type="checkbox"/> 配件 B.M. | <input type="checkbox"/> 樣辦或貨品說明書 | <input type="checkbox"/> 分判合約 |
| <input type="checkbox"/> 其他：_____ | | |

內容：

現，確認附頁模圖，煩請按此生產模圖共17個：
 X85516, X85517, X85518, X85519, X85520, X85521, X85522, X85523,
 X85524, X85525, ~~_____~~, X85527, X85528, X85529, X85530, X85531,
 X85532, X85533, ~~_____~~
 (WW2用)

請在 2018/6/22 前完成上列要求。

附有關圖紙 / 文件：

17張模圖

以上項目為：

- 原合約工程包 原合約工程加 / 減賬 新工程報價

原因：-

分發東莞各部門：

- () 生產技術總監 連附件 () 技術部 連附件 () 生產部 連附件 () 機械設計部 連附件
 () 採購部 連附件 () 生產統籌部 連附件
 () 質檢部 連附件 () 會計部 連附件 () 報關組 連附件 () 其他 _____ 連附件

分發香港各部門：

- () 行政部 連附件 () 會計部 連附件 () 統籌部 連附件 () 工程部地盤科文 連附件
 () 採購部 連附件 () QS 部 連附件 () 維修部 連附件 () 其他 _____ 連附件

傳遞編號：HK 0899 / 18

發件人簽署：[Signature]

項目經理簽署：[Signature]

CUSTOMER	HONGKONG CO.	CUSTOMER APPROVAL	CUST PART NO.	X85516
			SECTION NO.	LH0089691

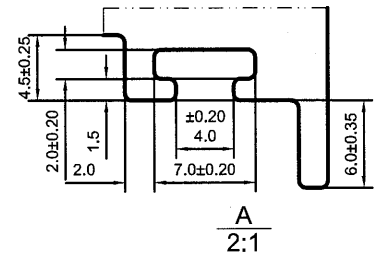
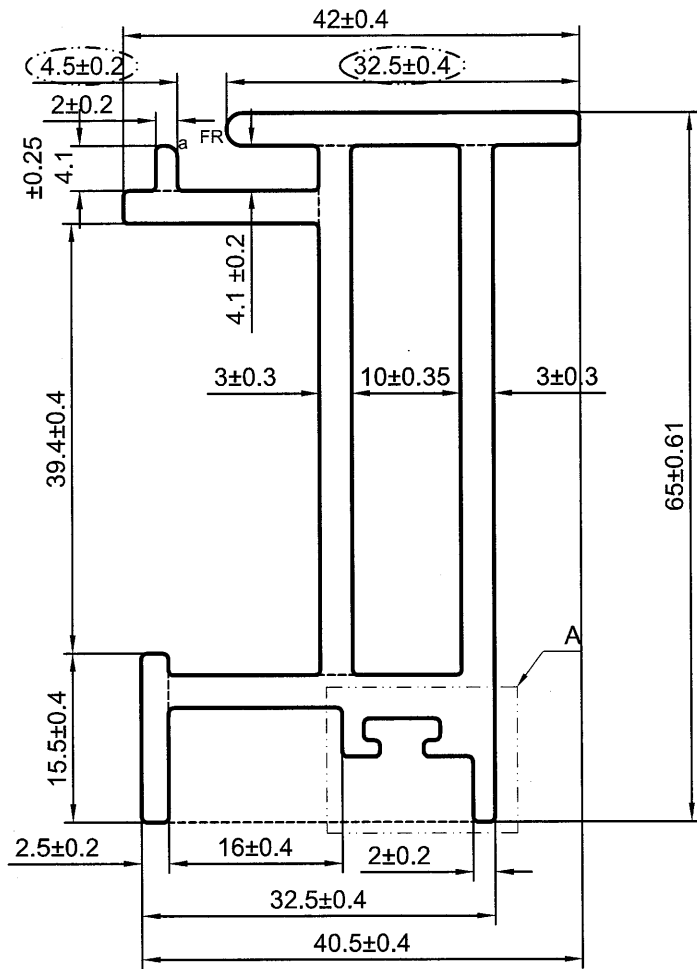

美特鋁質有限公司	
承認圖面	
日期	30/5/2018

----- 次要装饰面, 喷涂膜厚不足, 但不露底
 - - - - - 装饰面

LH0089694
X85519

*配合尺寸以实物配合效果为准!

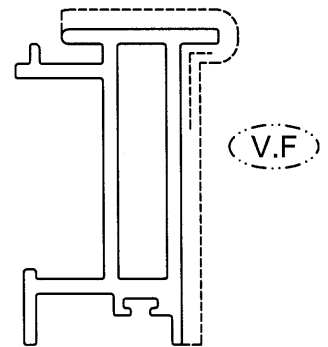
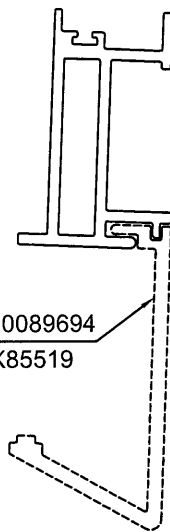

SCALE 1:2

SCALE 1:1.5

SIGNATURE GRADEING	HIGH SIGNATURE GRADEING	C.C.DIA(MM)	Ø 76.21						
AREA (SQ MM)	633.43	UNSPECIFIED THICKNESS	3±0.25	PERIMETER (MM)	301.83	STANDARD	GB 5237.1	SCALE	1.5:1
MASS (KG/M)	1.717	UNSPECIFIED CORNERS	R 0.5	SURFACE AREA	108.35	ALLOY	6063-T6	VERSION	A
COMPANY ISSUE		A	DRAWA	蔡晓婷	DATE	2018-05-18	APPELLATION	-	PAGE OF
			STANDA-RDIZATION		DATE				
			TO SIGN	陈国提	DATE				
			AUDITING		DATE				
MARKER	MODIFY	FILE NO	SIGNATURE	DATE	APPROV				

PANASIA ALUMINUM (CHINA) LIMITED

CUSTOMER	HONGKONG CO.	CUSTOMER APPROVAL	CUST PART NO.	X85517
			SECTION NO.	LH0089692

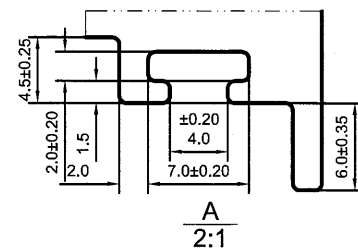
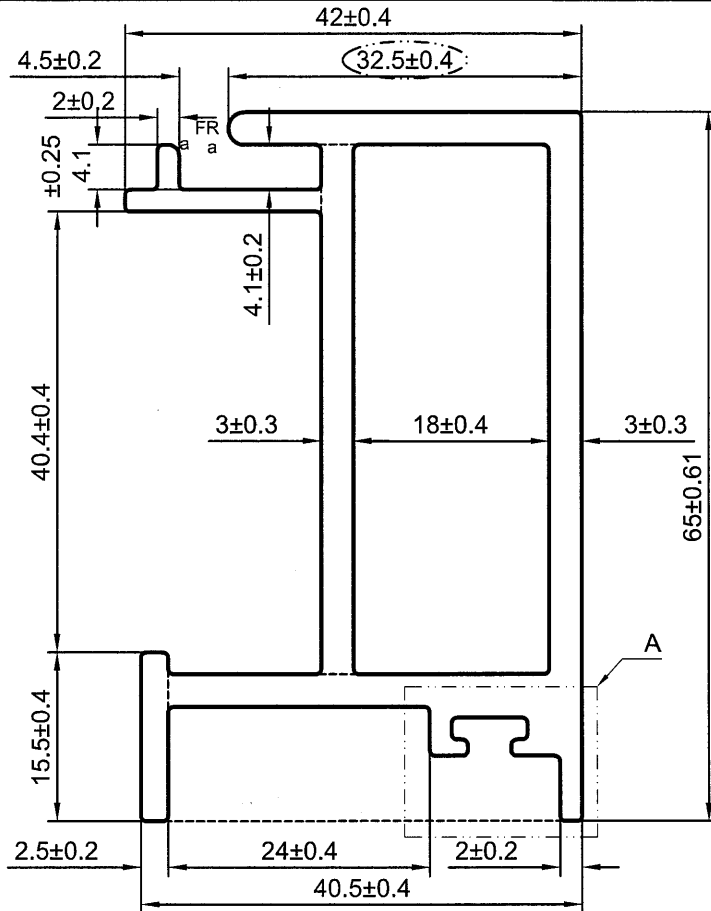

美特鋁質有限公司	
承認圖面	
日期	30/5/2018

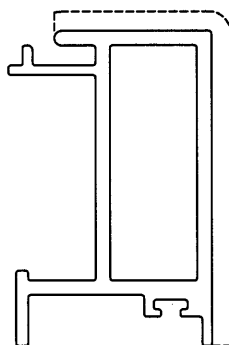

V.F

a=R1.0

SCALE 1:1.5

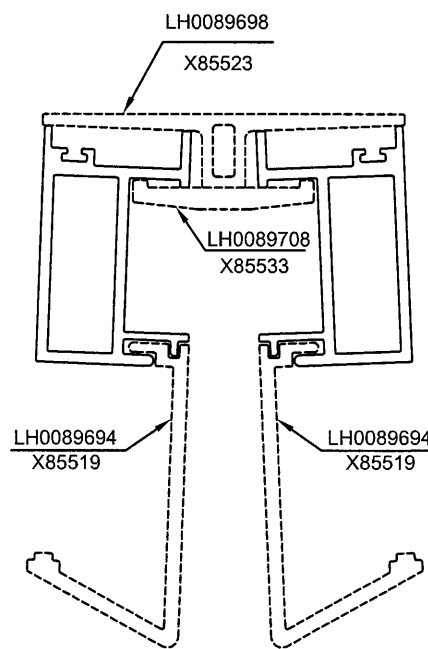

SCALE 1:2

*配合尺寸以实物配合效果为准!

SIGNATURE GRADEING	HIGH SIGNATURE GRADEING	C.C.DIA(MM)	Ø 76.21						
AREA (SQ MM)	639.43	UNSPECIFIED THICKNESS	3±0.25	PERIMETER (MM)	302.26	STANDARD	GB 5237.1	SCALE	1.5:1
MASS (KG/M)	1.733	UNSPECIFIED CORNERS	R 0.5	SURFACE AREA	100.78	ALLOY	6063-T6	VERSION	A
COMPANY ISSUE		A	DRAWA	蔡晓婷	DATE	2018-05-17	APPELLATION	-	PAGE OF
			STANDA-RDIZATION		DATE				
			TO SIGN	陈国提	DATE				
			AUDITING		DATE				
MARKER	MODIFY	FILE NO	SIGNATURE	DATE	APPROV				



CUSTOMER	HONGKONG CO.	CUSTOMER APPROVAL		CUST PART NO.	X85518
				SECTION NO.	LH0089693

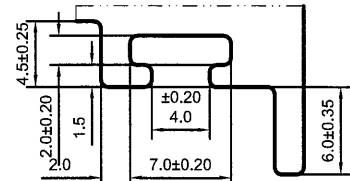
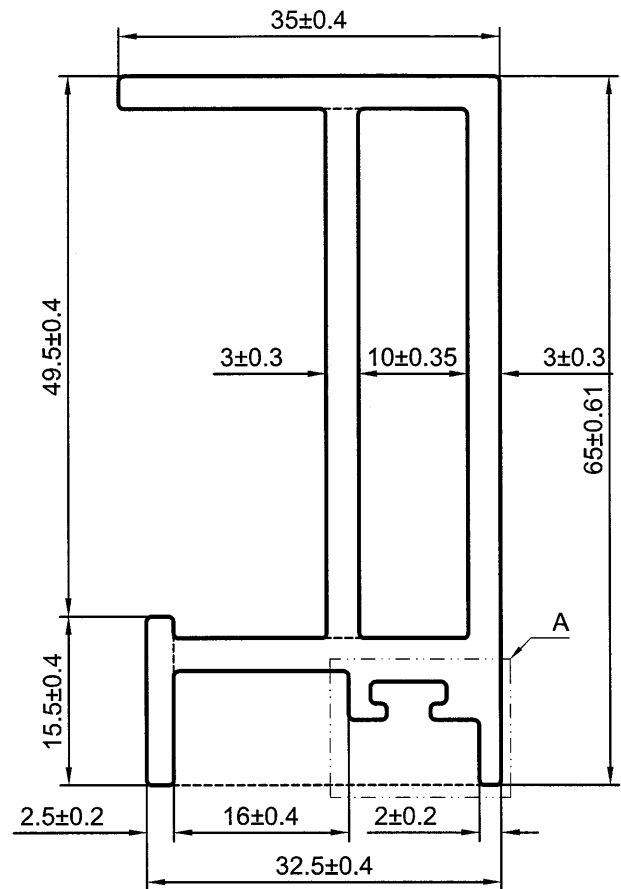

A
2:1

美特鋁質有限公司	
承認圖面	
日期	20/5/2018

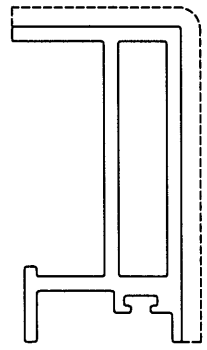

V.F

SCALE 1:1.5

*配合尺寸以实物配合效果为准!

SIGNATURE GRADEING	HIGH SIGNATURE GRADEING	C.C.DIA(MM)	Ø 73.47						
AREA (SQ MM)	579.75	UNSPECIFIED THICKNESS	3±0.25	PERIMETER (MM)	265.85	STANDARD	GB 5237.1	SCALE	1.5:1
MASS (KG/M)	1.571	UNSPECIFIED CORNERS	R 0.5	SURFACE AREA	100.36	ALLOY	6063-T6	VERSION	A
COMPANY ISSUE		A	DRAWN	蔡晓婷	DATE	2018-05-17	APPELLATION	-	PAGE OF
			STANDARDIZATION		DATE				
			TO SIGN	陈国提	DATE				
			AUDITING		DATE				
MARKER	MODIFY	FILE NO	SIGNATURE	DATE	APPROV	DATE			

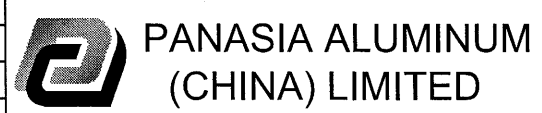

4.

CUSTOMER	HONGKONG CO.	CUSTOMER APPROVAL	CUST PART NO.	X85519
			SECTION NO.	LH0089694

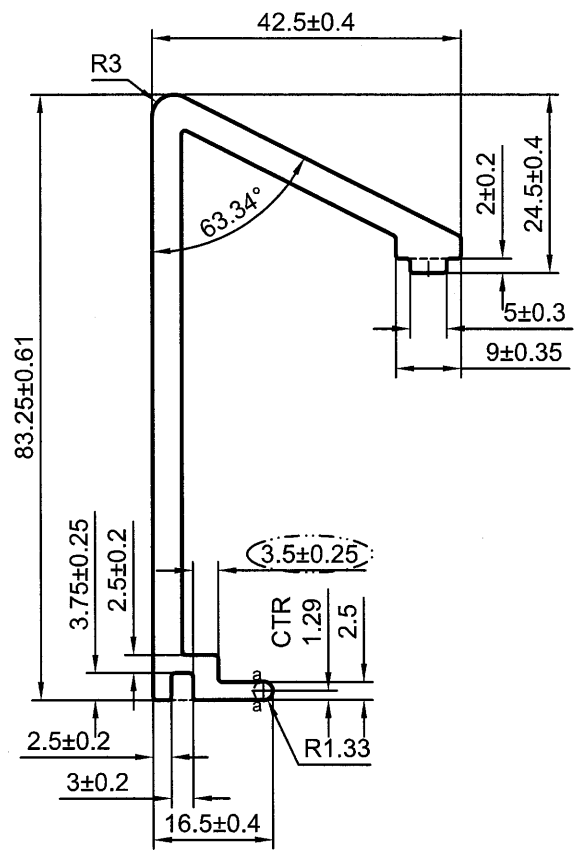

美特铝质有限公司	
承認圖面	
日期	30/5/2018

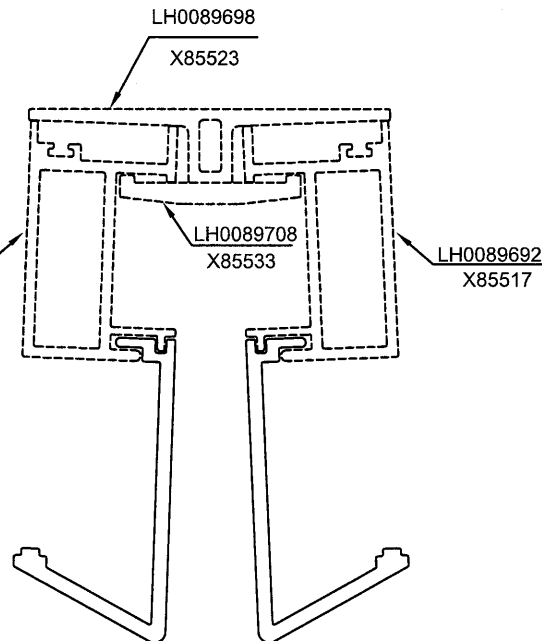
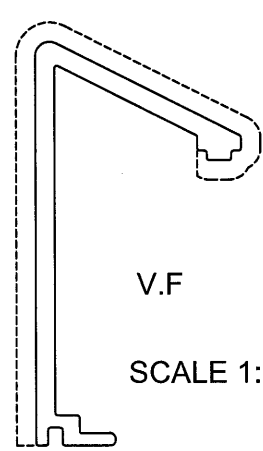

a=R0.8

*配合尺寸以实物配合效果为准!

SIGNATURE GRADEING	HIGH SIGNATURE GRADEING	C.C.DIA(MM)	Ø 84.23						
AREA (SQ MM)	558.81	UNSPECIFIED THICKNESS	4±0.25	PERIMETER (MM)	291.55	STANDARD	GB 5237.1	SCALE	1:1
MASS (KG/M)	1.514	UNSPECIFIED CORNERS	R 0.5	SURFACE AREA	144.50	ALLOY	6063-T6	VERSION	A
COMPANY ISSUE		A	DRAWA	蔡晓婷	DATE	2018-05-17	APELLATION	-	PAGE OF
			STANDA-RDIZATION		DATE				
			TO SIGN	陈国提	DATE				
			AUDITING		DATE				
MARKER	MODIFY	FILE NO	SIGNATURE	DATE	APPROV	DATE			

CUSTOMER	HONGKONG CO.	CUSTOMER APPROVAL	CUST PART NO.	X85521
			SECTION NO.	LH0089696

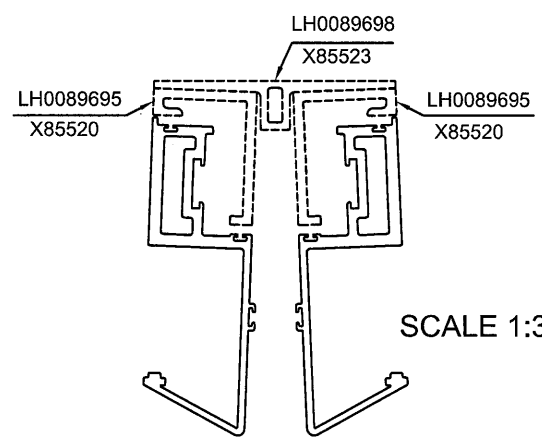
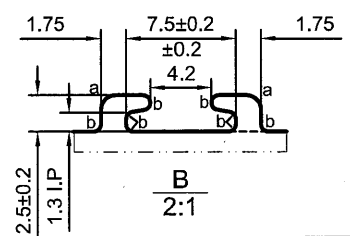
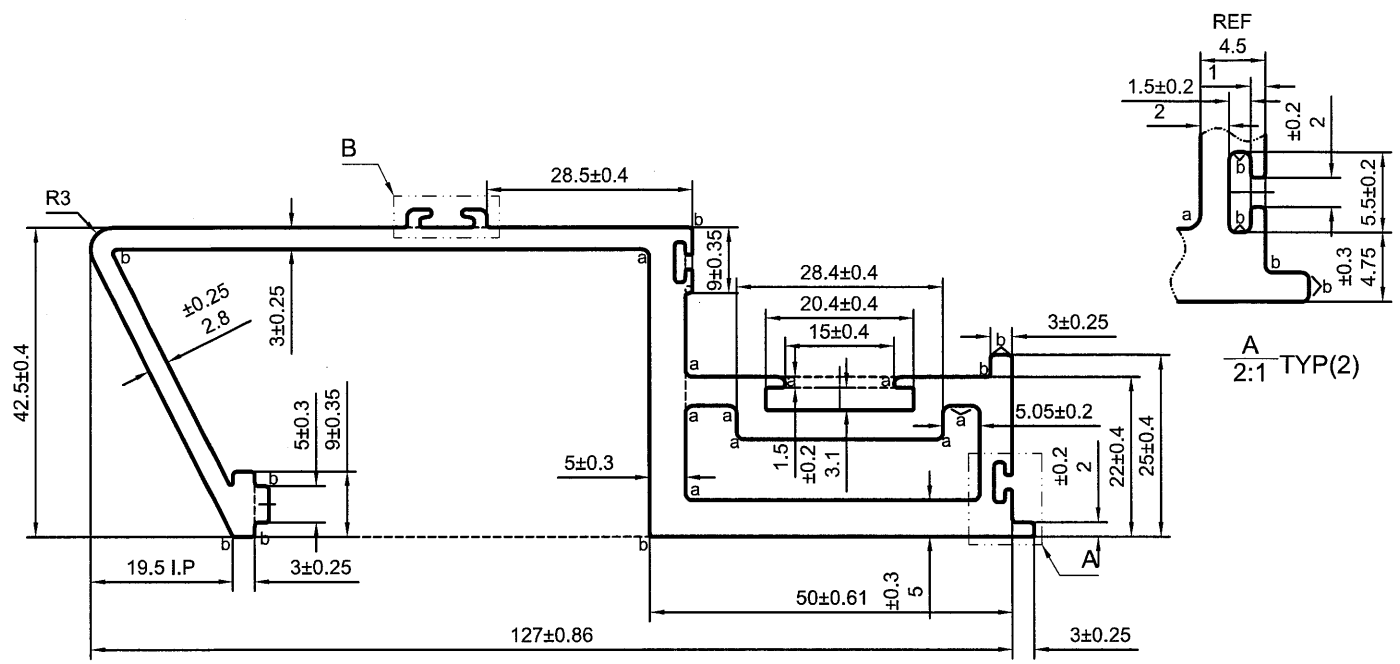

美特鋁質有限公司
承認圖面
日期 30/5/2008

a=R1 b=R0.5

--- 次要裝飾面，噴塗膜厚不足，但不露底
- - - 裝飾面
●●●●● 凹槽位置可能有露底現象，即膜厚不足

*配合尺寸以实物配合效果为准！

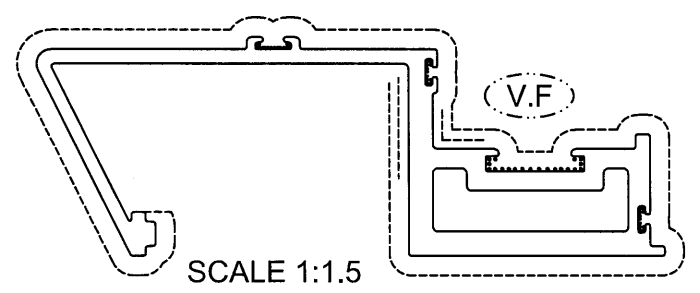

SIGNATURE GRADEING	HIGH SIGNATURE GRADEING	C.C.DIA(MM)	Ø135.87						
AREA (SQ MM)	1117.46	UNSPECIFIED THICKNESS	4±0.25	PERIMETER (MM)	498.04	STANDARD	GB 5237.1	SCALE	1:1
MASS (KG/M)	3.028	UNSPECIFIED CORNERS	R 0.5	SURFACE AREA	384.81	ALLOY	6063-T6	VERSION	A
COMPANY ISSUE		A	DRAWA	蔡晓婷	DATE	2018-05-17	APELLATION	-	PAGE OF
			STANDARDIZATION		DATE				
			TO SIGN	陈国提	DATE				
			AUDITING		DATE				
MARKER	MODIFY	FILE NO	SIGNATURE	DATE	APPROV	DATE			

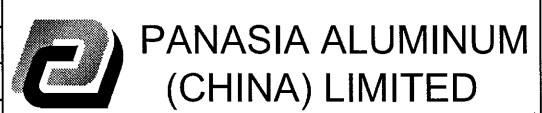

CUSTOMER	HONGKONG CO.	CUSTOMER APPROVAL	CUST PART NO.	X85522
			SECTION NO.	LH0089697

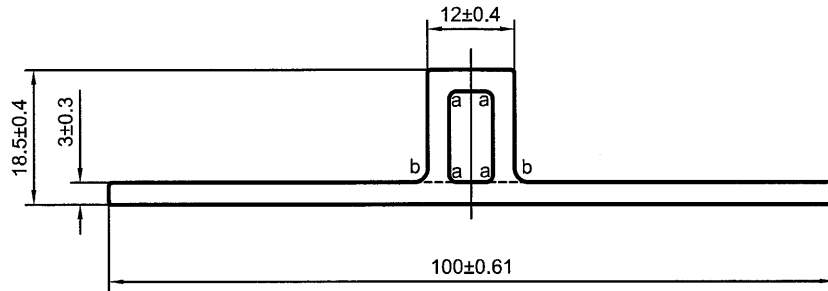

美特鋁質有限公司	
承認圖面	
日期	30/5/2018

a=R1 b=R2

----- 次要装饰面，喷涂膜厚不足，但不露底
 _____ 装饰面

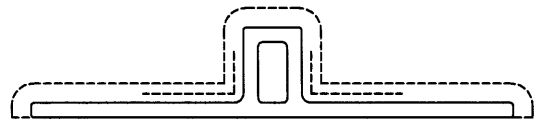

*配合尺寸以实物配合效果为准！

SCALE 1:1.5

(V.F)

SIGNATURE GRADEING	HIGH SIGNATURE GRADEING	C.C.DIA(MM)	Ø100.02		SCALE 1:1.5 (V.F)				
AREA (SQ MM)	413.25	UNSPECIFIED THICKNESS	3±0.25	PERIMETER (MM)	234	STANDARD	GB 5237.1	SCALE	1:1
MASS (KG/M)	1.12	UNSPECIFIED CORNERS	R 0.5	SURFACE AREA	135	ALLOY	6063-T6	VERSION	A
COMPANY ISSUE		A	DRAWA	蔡晓婷	DATE	2018-05-18	APELLATION	-	PAGE OF
			STANDA-RDIZATION		DATE				
			TO SIGN	陈国提	DATE				
			AUDITING		DATE				
MARKER	MODIFY	FILE NO	SIGNATURE	DATE	APPROV	DATE			



PANSASIA ALUMINUM (CHINA) LIMITED

CUSTOMER	HONGKONG CO.	CUSTOMER APPROVAL	CUST PART NO.	X85523
			SECTION NO.	LH0089698

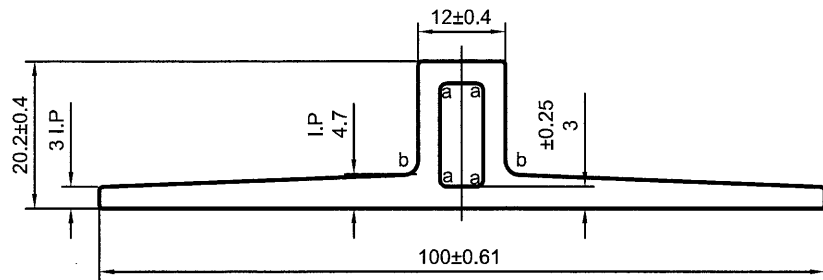

美特鋁質有限公司	
承認圖面	
日期	30/5/2013

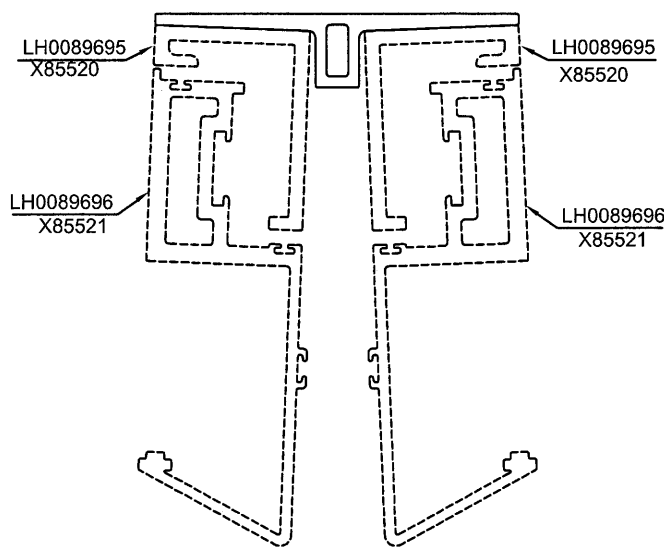

SCALE 1:2

a=R1 b=R2

----- 次要装饰面, 喷涂膜厚不足, 但不露底
 - - - - - 装饰面

*配合尺寸以实物配合效果为准!

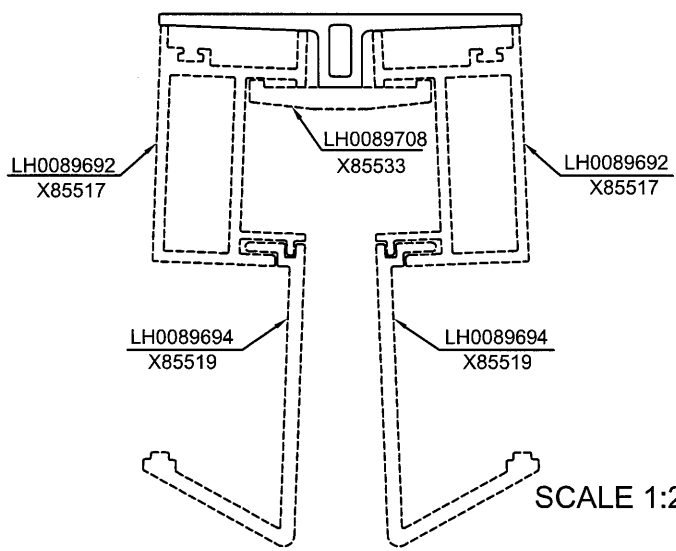

SCALE 1:2

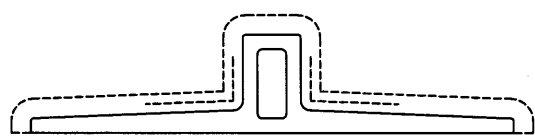

SCALE 1:1.5

V.F.

SIGNATURE GRADEING	HIGH SIGNATURE GRADEING	C.C.DIA(MM)	Ø100.02						
AREA (SQ MM)	498.42	UNSPECIFIED THICKNESS	3±0.25	PERIMETER (MM)	234.25	STANDARD	GB 5237.1	SCALE	1:1
MASS (KG/M)	1.351	UNSPECIFIED CORNERS	R 0.5	SURFACE AREA	135.25	ALLOY	6063-T6	VERSION	A
COMPANY ISSUE		A	DRAWA	蔡晓婷	DATE	2018-05-18	APPELLATION	-	PAGE OF
			STANDARDIZATION		DATE				
			TO SIGN	陈国提	DATE				
			AUDITING		DATE				
MARKER	MODIFY	FILE NO	SIGNATURE	DATE	APPROV				

PANASIA ALUMINUM (CHINA) LIMITED

CUSTOMER	HONGKONG CO.	CUSTOMER APPROVAL		CUST PART NO.	X85524
				SECTION NO.	LH0089699

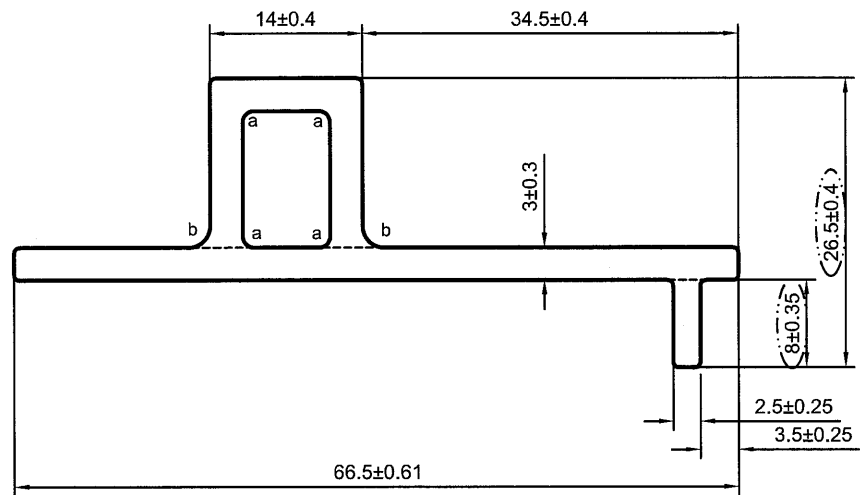

美特铝质有限公司	
承認圖面	
日期	30/5/2018

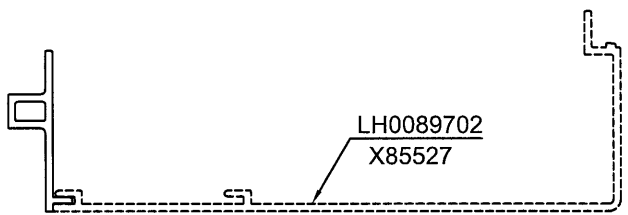

SCALE 1:3

a=R1 b=R2

----- 次要装饰面，喷涂膜厚不足，但不露底
 - - - - - 装饰面

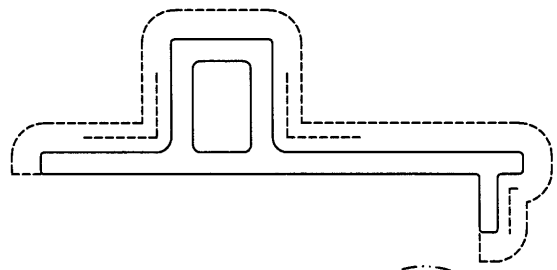

SCALE 1:1

V.F.

*配合尺寸以实物配合效果为准！

SIGNATURE GRADEING	HIGH SIGNATURE GRADEING	C.C.DIA(MM)	Ø66.53						
AREA (SQ MM)	338.75	UNSPECIFIED THICKNESS	3±0.25	PERIMETER (MM)	182.14	STANDARD	GB 5237.1	SCALE	1.5:1
MASS (KG/M)	0.918	UNSPECIFIED CORNERS	R 0.5	SURFACE AREA	114.85	ALLOY	6063-T6	VERSION	A
COMPANY ISSUE		A	DRAWA	蔡晓婷	DATE	2018-05-24	APELLATION	-	PAGE OF
			STANDARDIZATION		DATE				
			TO SIGN	陈国提	DATE				
			AUDITING		DATE				
MARKER	MODIFY	FILE NO	SIGNATURE	DATE	APPROV				

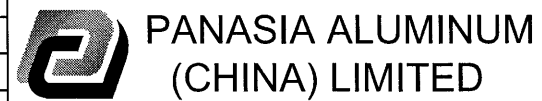

CUSTOMER	HONGKONG CO.	CUSTOMER APPROVAL	CUST PART NO.	X85525
			SECTION NO.	LH0089700

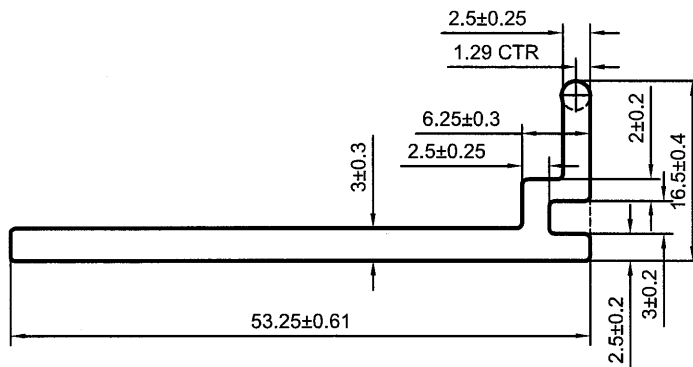

美特铝质有限公司	
承認圖面	
日期	30/5/2018

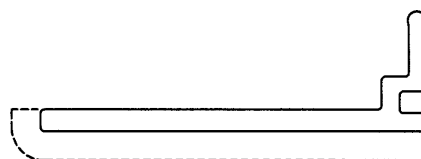

*配合尺寸以实物配合效果为准!

SCALE 1:1 V.F

SIGNATURE GRADEING	HIGH SIGNATURE GRADEING	C.C.DIA(MM)	Ø55.33		SCALE 1:1		V.F		
AREA (SQ MM)	198.5	UNSPECIFIED THICKNESS	-	PERIMETER (MM)	143.88	STANDARD	GB 5237.1	SCALE	1.5:1
MASS (KG/M)	0.538	UNSPECIFIED CORNERS	R 0.5	SURFACE AREA	56.61	ALLOY	6063-T6	VERSION	A
COMPANY ISSUE		A	DRAWA	蔡晓婷	DATE	2018-05-18	APPELLATION	-	PAGE OF
			STANDARDIZATION		DATE				
			TO SIGN	陈国提	DATE				
			AUDITING		DATE				
MARKER	MODIFY	FILE NO	SIGNATURE	DATE	APPROV	DATE			

PANASIA ALUMINUM (CHINA) LIMITED

CUSTOMER	HONGKONG CO.	CUSTOMER APPROVAL	CUST PART NO.	X85527
			SECTION NO.	LH0089702

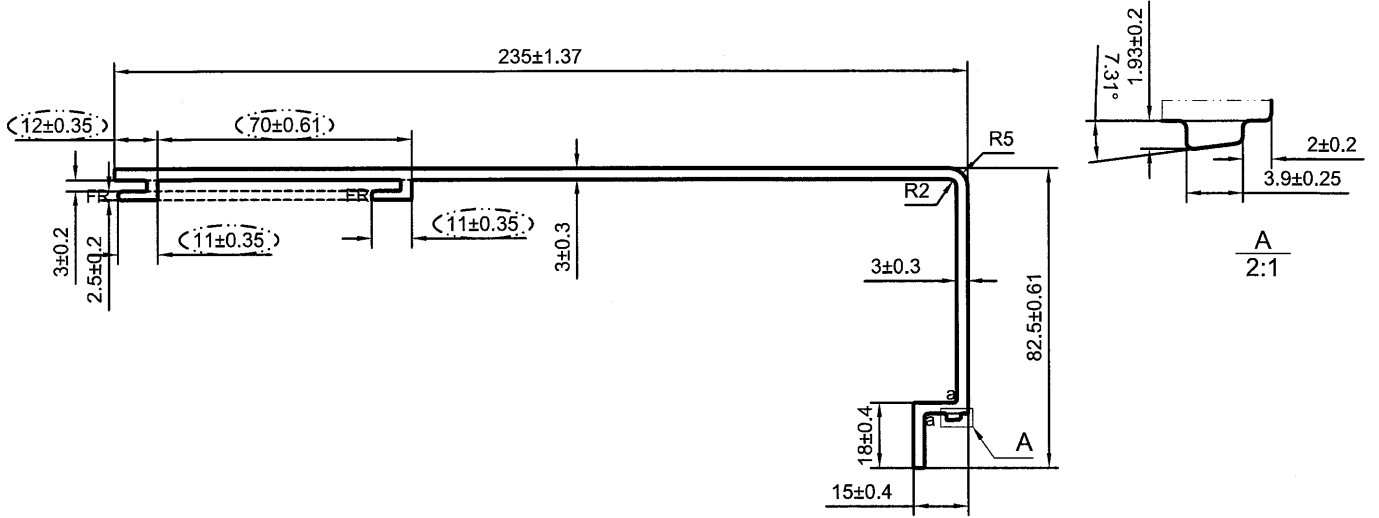

美特鋁質有限公司	
承認圖面	
日期	30/5/2018

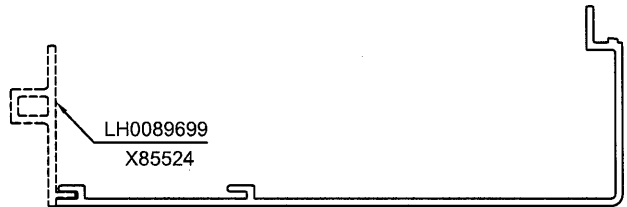

SCALE 1:3

a=R1

-----	次要裝飾面，噴塗膜厚不足，但不露底
-----	裝飾面
●●●●●●	凹槽位置可能會有露底現象，即膜厚不足

*配合尺寸以实物配合效果为准！

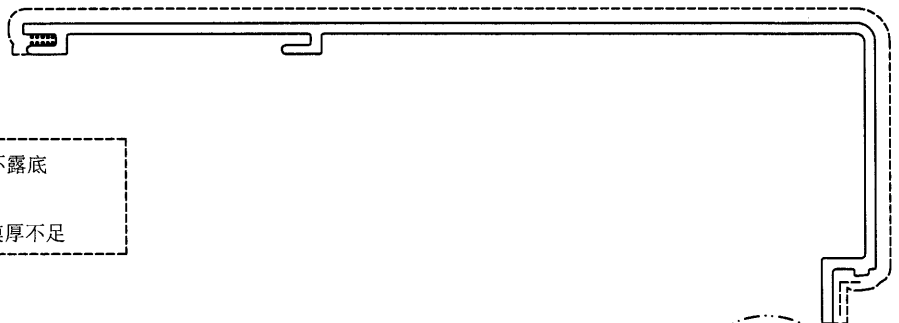

SCALE 1:2

V.F.

SIGNATURE GRADEING	HIGH SIGNATURE GRADEING	C.C.DIA(MM)	Ø244.27						
AREA (SQ MM)	1053.79	UNSPECIFIED THICKNESS	3±0.25	PERIMETER (MM)	706.64	STANDARD	GB 5237.1	SCALE	1:2
MASS (KG/M)	2.856	UNSPECIFIED CORNERS	R 0.5	SURFACE AREA	354.47	ALLOY	6063-T5	VERSION	A
COMPANY ISSUE		A	DRAWA	蔡晓婷	DATE	2018-05-24	APPELLATION	-	PAGE OF
			STANDA-RDIZATION		DATE				
			TO SIGN	陈国提	DATE				
			AUDITING		DATE				
MARKER	MODIFY	FILE NO	SIGNATURE	DATE	APPROV		DATE		

PANASIA ALUMINUM (CHINA) LIMITED

CUSTOMER	HONGKONG CO.	CUSTOMER APPROVAL	CUST PART NO.	X85528
			SECTION NO.	LH0089703

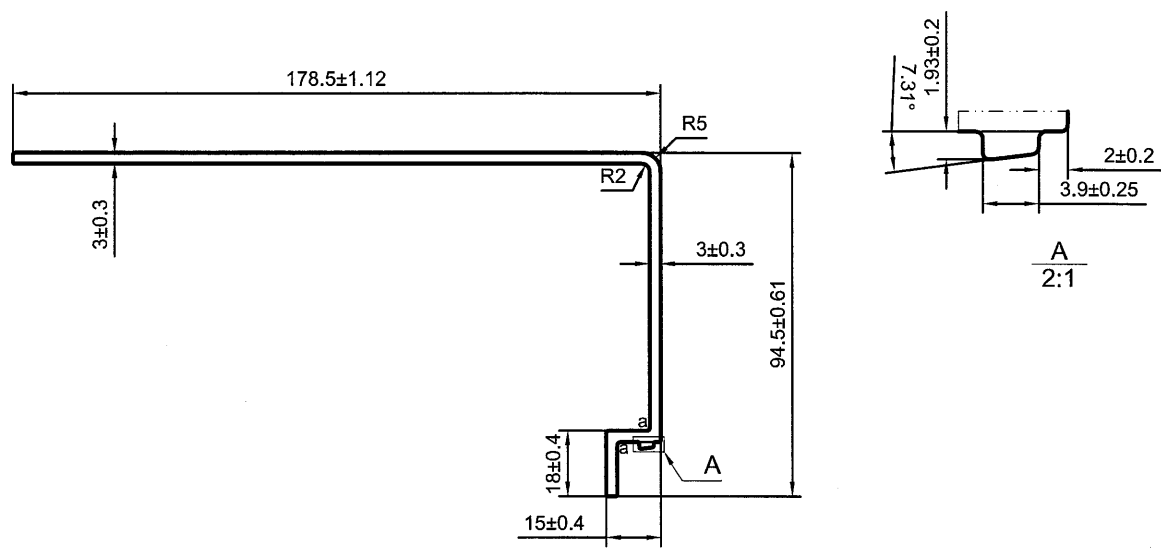

美特鋁質有限公司	
承認圖面	
日期	30/5/2018

a=R1

----- 次要装饰面，喷涂膜厚不足，但不露底
 ----- 装饰面

*配合尺寸以实物配合效果为准！

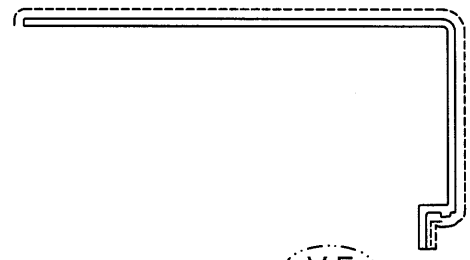

SCALE 1:3

V.F.

SIGNATURE GRADEING	HIGH SIGNATURE GRADEING	C.C.DIA(MM)	Ø195.08						
AREA (SQ MM)	848.42	UNSPECIFIED THICKNESS	3±0.25	PERIMETER (MM)	567.51	STANDARD	GB 5237.1	SCALE	1:2
MASS (KG/M)	2.299	UNSPECIFIED CORNERS	R 0.5	SURFACE AREA	288.22	ALLOY	6063-T5	VERSION	A
COMPANY ISSUE		A	DRAWA	蔡晓婷	DATE	2018-05-23	APPELLATION	-	PAGE OF
			STANDARDIZATION		DATE				
			TO SIGN	陈国提	DATE				
			AUDITING		DATE				
MARKER	MODIFY	FILE NO	SIGNATURE	DATE	APPROV				

PANASIA ALUMINUM (CHINA) LIMITED

13

CUSTOMER	HONGKONG CO.	CUSTOMER APPROVAL	CUST PART NO.	X85529
			SECTION NO.	LH0089704

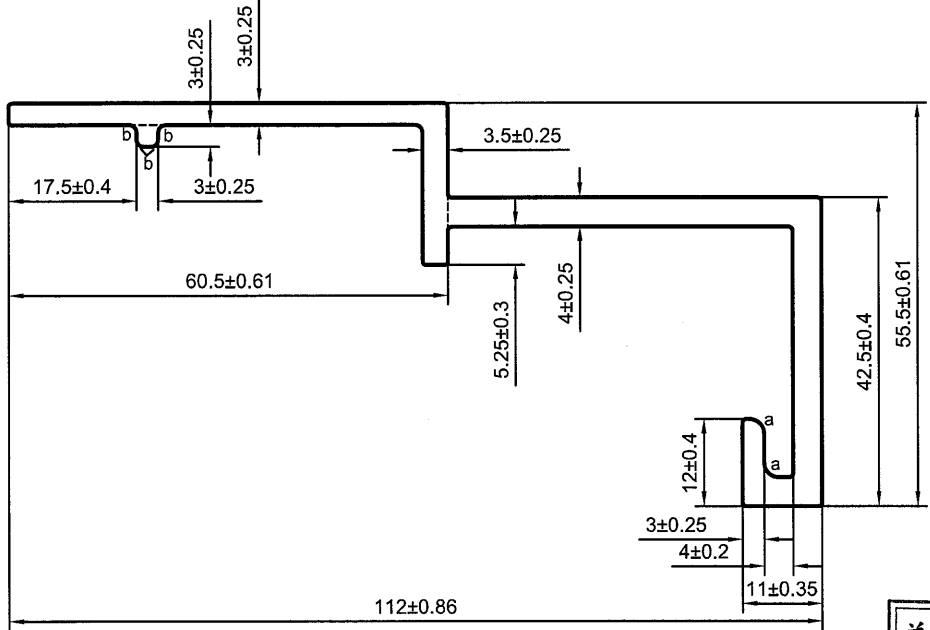

美特鋁質有限公司	
承認圖面	
日期	30/5/2018

a=R2 b=R1

----- 次要裝飾面，噴塗膜厚不足，但不露底
 裝飾面
 ●●●●● 凹槽位置可能有露底現象，即膜厚不足

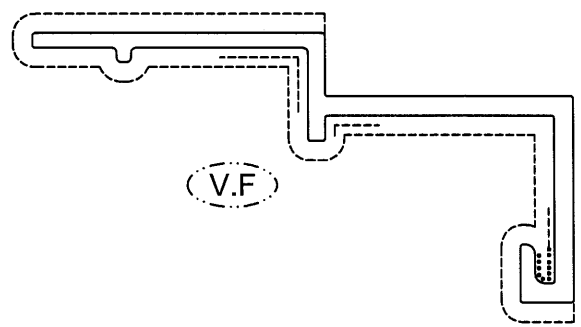

*配合尺寸以实物配合效果为准！

SCALE 1:1.5

SIGNATURE GRADEING	HIGH SIGNATURE GRADEING	C.C.DIA(MM)	Ø 124.66						
AREA (SQ MM)	669.82	UNSPECIFIED THICKNESS	4±0.25	PERIMETER (MM)	374.85	STANDARD	GB 5237.1	SCALE	1:1
MASS (KG/M)	1.815	UNSPECIFIED CORNERS	R 0.5	SURFACE AREA	269.28	ALLOY	6063-T6	VERSION	A
COMPANY ISSUE		A	DRAWA	蔡晓婷	DATE	2018-05-17	APPELLATION	-	PAGE OF
			STANDARDIZATION		DATE				
			TO SIGN	陈国提	DATE				
			AUDITING		DATE				
MARKER	MODIFY	FILE NO	SIGNATURE	DATE	APPROV				



14

CUSTOMER	HONGKONG CO.	CUSTOMER APPROVAL	CUST PART NO.	X85530
			SECTION NO.	LH0089705

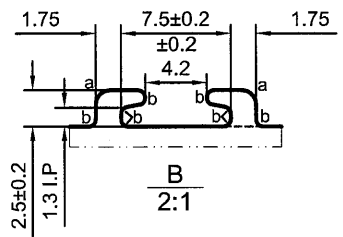
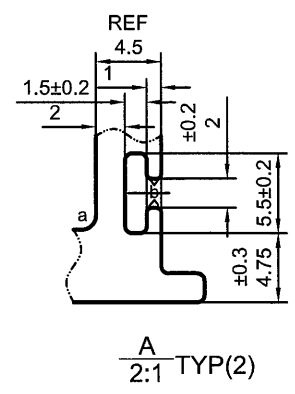
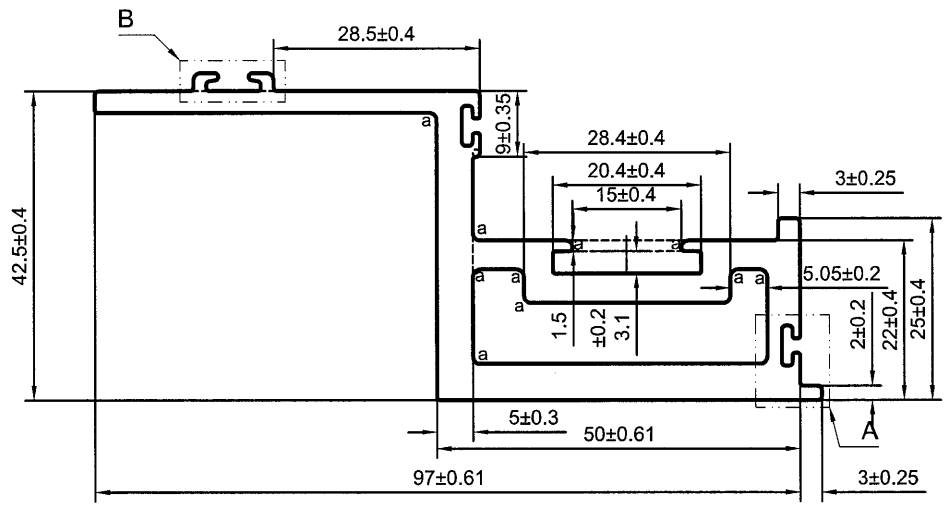

美特鋁質有限公司	
承認圖面	
日期	30/5/2018

a=R1 b=R0.3

----- 次要装饰面，喷涂膜厚不足，但不露底
 - - - - - 装饰面
 ●●●●● 凹槽位置可能会有露底现象，即膜厚不足

*配合尺寸以实物配合效果为准！

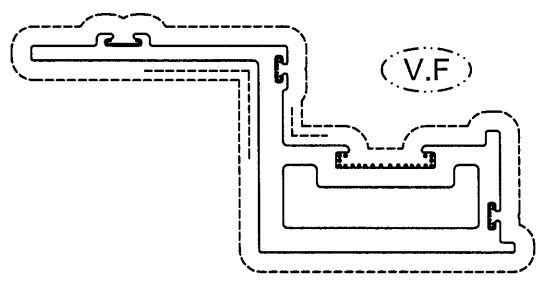

SCALE 1:1.5

SIGNATURE GRADEING	HIGH SIGNATURE GRADEING	C.C.DIA(MM)	Ø 108.35						
AREA (SQ MM)	878.13	UNSPECIFIED THICKNESS	4±0.25	PERIMETER (MM)	342.42	STANDARD	GB 5237.1	SCALE	1:1
MASS (KG/M)	2.38	UNSPECIFIED CORNERS	R 0.5	SURFACE AREA	342.42	ALLOY	6063-T6	VERSION	A
COMPANY ISSUE		A	DRAWA	蔡晓婷	DATE	2018-05-17	APELLATION	-	PAGE OF
			STANDA-RDIZATION		DATE				
			TO SIGN	陈国提	DATE				
			AUDITING		DATE				
MARKER	MODIFY	FILE NO	SIGNATURE	DATE	APPROV				

PANASIA ALUMINUM (CHINA) LIMITED

CUSTOMER	HONGKONG CO.	CUSTOMER APPROVAL	CUST PART NO.	X85531
			SECTION NO.	LH0089706

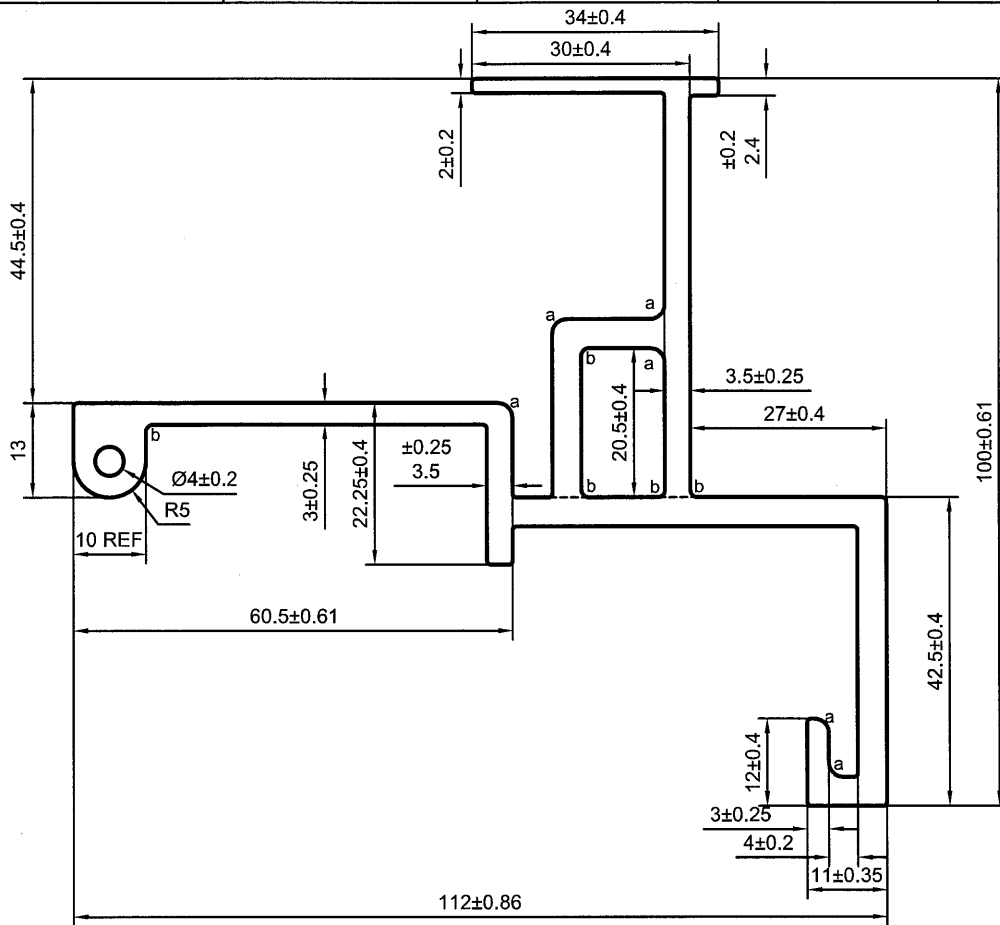

美特鋁質有限公司	
承認圖面	
日期	30/5/2018

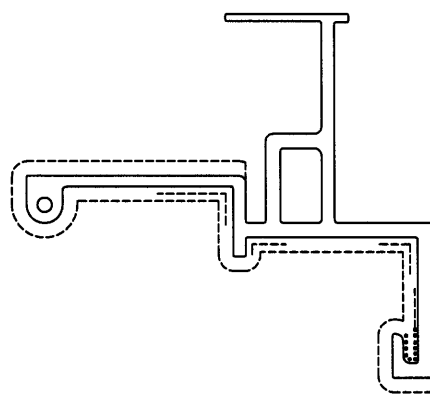

(V.F)

SCALE 1:2

a=R2 b=R1

- 次要裝飾面，噴塗膜厚不足，但不露底
- 裝飾面
- 凹槽位置可能會有露底現象，即膜厚不足

*配合尺寸以实物配合效果为准！

SIGNATURE GRADEING	HIGH SIGNATURE GRADEING	C.C.DIA(MM)	Ø 128.3						
AREA (SQ MM)	1146.34	UNSPECIFIED THICKNESS	4±0.25	PERIMETER (MM)	557.98	STANDARD	GB 5237.1	SCALE	1:1
MASS (KG/M)	3.107	UNSPECIFIED CORNERS	R 0.5	SURFACE AREA	281.56	ALLOY	6063-T6	VERSION	A
COMPANY ISSUE		A	DRAWA	蔡晓婷	DATE	2018-05-17	APELLATION	-	PAGE OF
			STANDARDIZATION		DATE				
			TO SIGN	陈国提	DATE				
			AUDITING		DATE				
MARKER	MODIFY	FILE NO	SIGNATURE	DATE	APPROV				



CUSTOMER	HONGKONG CO.	CUSTOMER APPROVAL	CUST PART NO.	X85532
			SECTION NO.	LH0089707

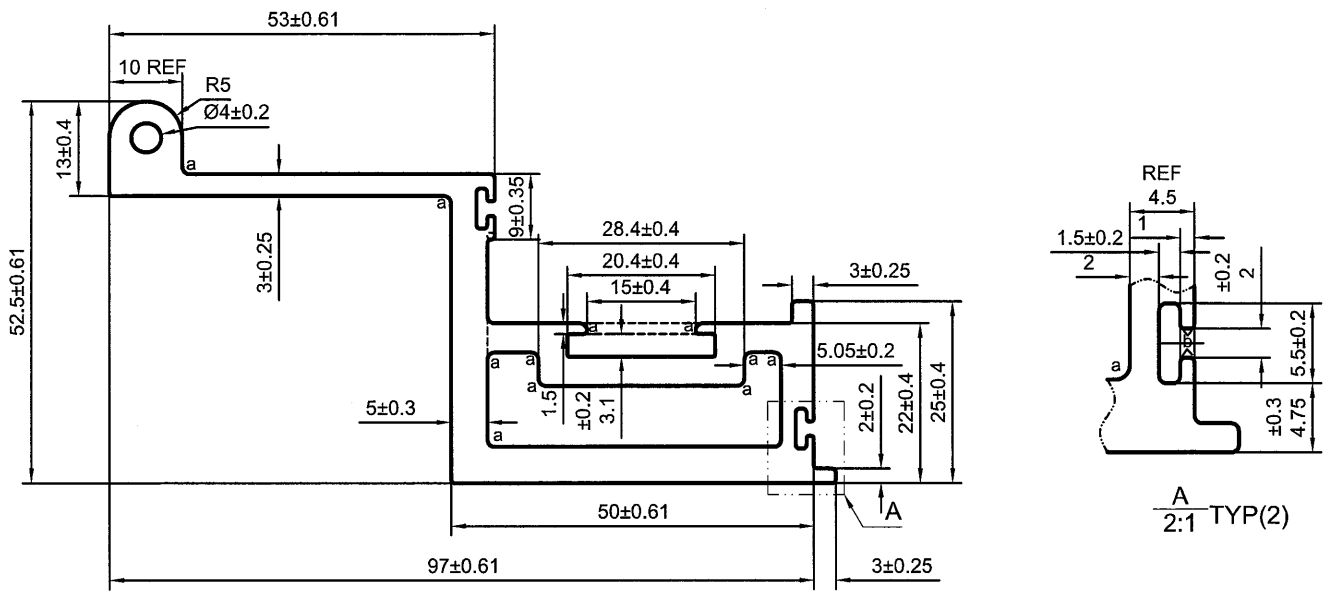

美特鋁質有限公司	
承認圖面	
日期	30/5/2018

a=R1 b=R0.3

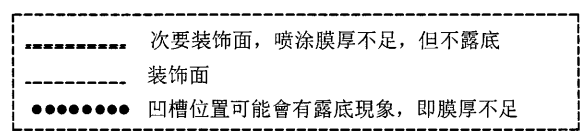

*配合尺寸以实物配合效果为准!

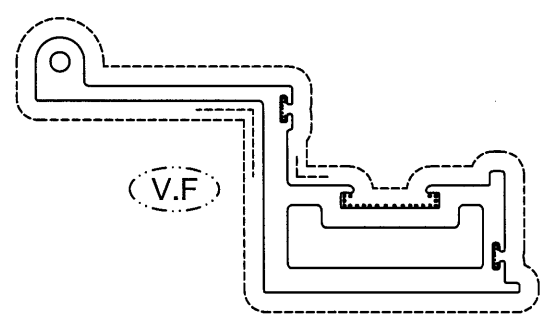

SCALE 1:1.5

SIGNATURE GRADEING	HIGH SIGNATURE GRADEING	C.C.DIA(MM)	Ø 111.04						
AREA (SQ MM)	943.15	UNSPECIFIED THICKNESS	4±0.25	PERIMETER (MM)	344.51	STANDARD	GB 5237.1	SCALE	1:1
MASS (KG/M)	2.556	UNSPECIFIED CORNERS	R 0.5	SURFACE AREA	344.51	ALLOY	6063-T6	VERSION	A
COMPANY ISSUE		A	DRAWA	蔡晓婷	DATE	2018-05-18	APPELLATION	-	PAGE OF
			STANDARDIZATION		DATE				
			TO SIGN	陈国提	DATE				
			AUDITING		DATE				
MARKER	MODIFY	FILE NO	SIGNATURE	DATE	APPROV				



CUSTOMER	HONGKONG CO.	CUSTOMER APPROVAL		CUST PART NO.	X85533
				SECTION NO.	LH0089708

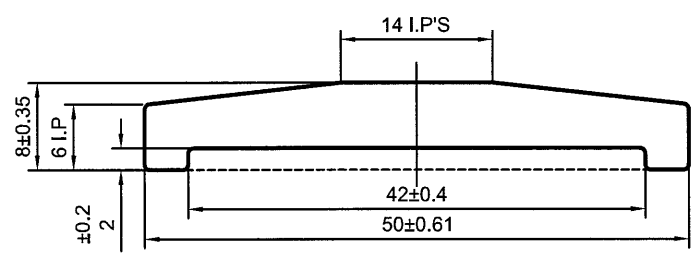

美特鋁質有限公司
承認圖面
日期 30/5/2018

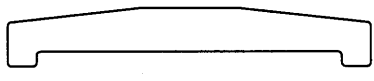

NO V.F SCALE 1:1

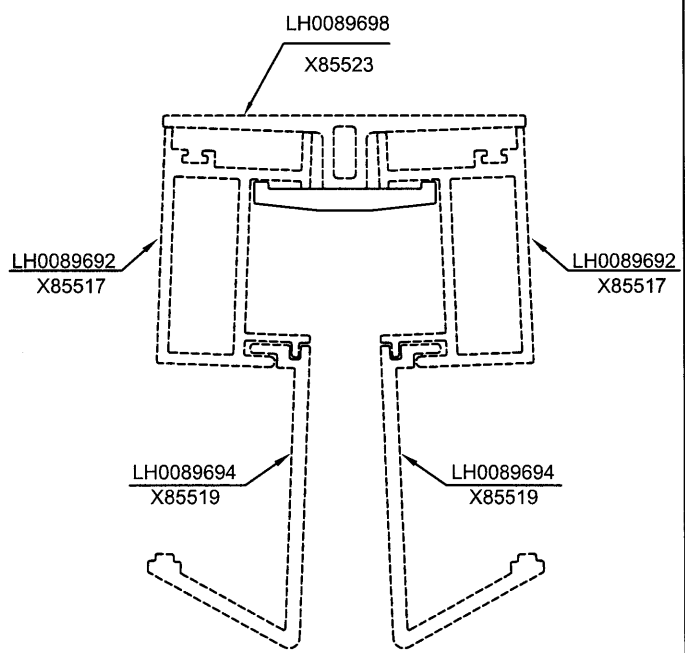

SCALE 1:2

*配合尺寸以实物配合效果为准!

SIGNATURE GRADEING	HIGH SIGNATURE GRADEING	C.C.DIA(MM)	Ø 50.26						
AREA (SQ MM)	279.93	UNSPECIFIED THICKNESS	-	PERIMETER (MM)	114.62	STANDARD	GB 5237.1	SCALE	1.5:1
MASS (KG/M)	0.759	UNSPECIFIED CORNERS	R 0.5	SURFACE AREA	344.51	ALLOY	6063-T6	VERSION	A
COMPANY ISSUE		A	DRAWA	蔡晓婷	DATE	2018-05-18	APELLATION	-	PAGE OF
			STANDARDIZATION		DATE				
			TO SIGN	陈国提	DATE				
			AUDITING		DATE				
MARKER	MODIFY	FILE NO	SIGNATURE	DATE	APPROV	DATE			